

Latitude 38

# Latitude 38

VOLUME 397 July 2010

WE GO WHERE THE WIND BLOWS

JULY 2010

VOLUME 397

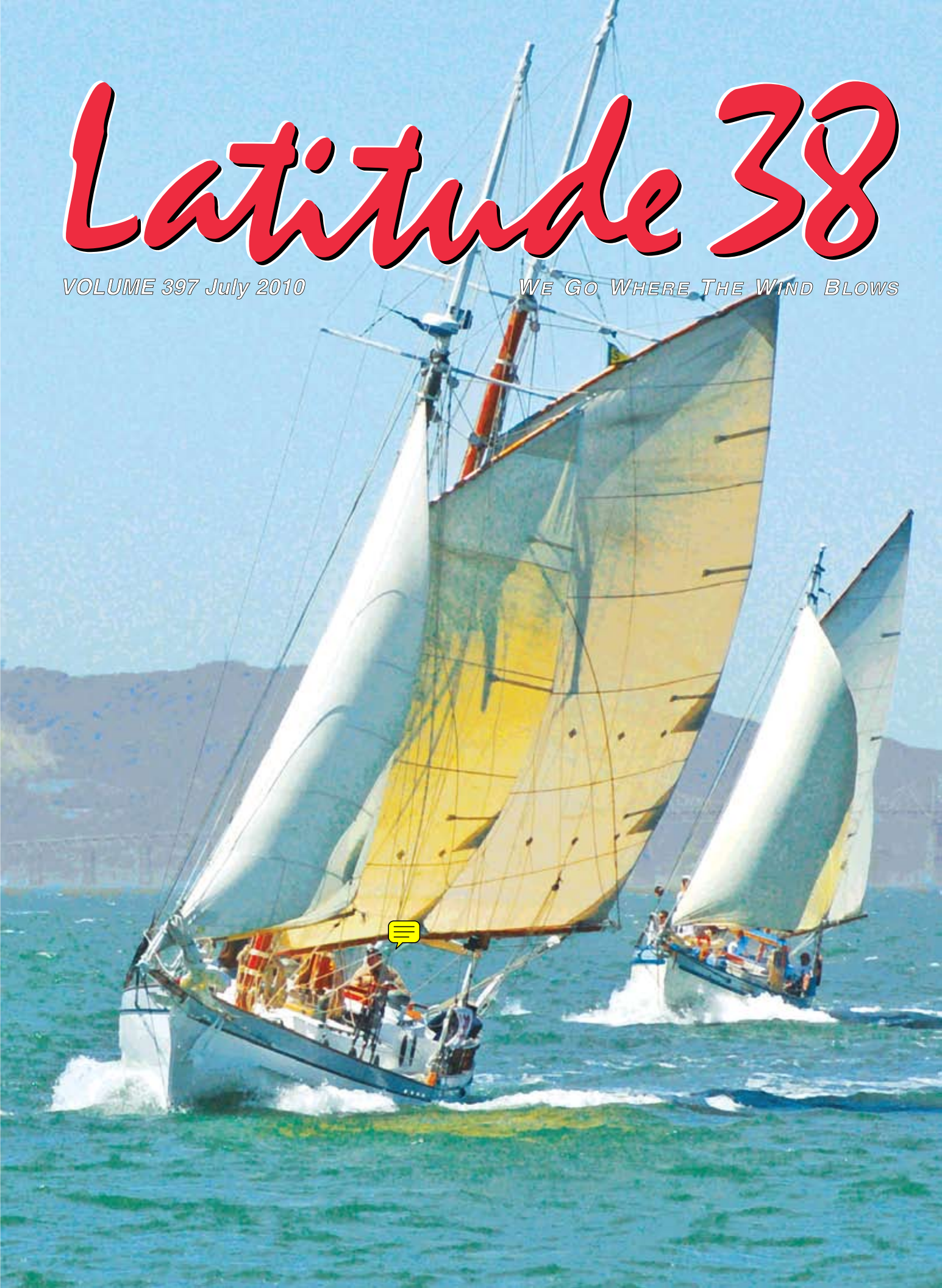

# Happy Independence Day!



*Boaters in general have a very independent streak. We like to be self-sufficient and ready to go at a moment's notice. Join Grand Marina in celebration of the true meaning of this historically important holiday.*

- Prime deep water concrete slips in a variety of sizes
- Great Estuary location at the heart of the beautiful Alameda Island
- Complete bathroom and shower facility, heated and tiled
- FREE pump out station open 24/7
- Full Service Marine Center and haul out facility
- Free parking
- Free WiFi on site!
- And much more...

<b>DIRECTORY of                      GRAND MARINA                      TENANTS</b>	
Bay Island Yachts .....	12
Blue Pelican Marine.....	168
The Boat Yard at Grand Marina...	13
Lee Sails.....	164
Marine Lube.....	168
Pacific Crest Canvas.....	55
Pacific Yacht Imports .....	6
Rooster Sails .....	109
UK-Halsey Sailmakers.....	58



**GRAND MARINA**  
 ANDERSON-ENCINAL

**510-865-1200**

Leasing Office Open Daily  
 2099 Grand Street, Alameda, CA 94501  
[www.grandmarina.com](http://www.grandmarina.com)

# In with the Old, In with the New

PHOTO: BILL RUPERT



**Bolero\***

Tim Murison has every right to brag! His beautiful Island Clipper, *Bolero*, built in 1946, won this year's Ensenada Race.

His 64-year-old boat sailed the 63rd anniversary of that race with a crew whose age averaged 62. Only *Bolero's* suit of Pineapple Sails was brand new.

Tim opted to leave *Bolero* in Southern California on his return from Mexico and raced San Diego's Yesteryear Regatta, winning 1st in class and 1st overall among a large fleet of equally classic old boats.

Tim understands the importance of connecting with his sailmaker, whether for a traditional old boat like his Island Clipper or this year's model, a sailmaker who pays attention to both his boat and his kind of sailing, providing only quality sails, superior performance and unwavering service. Tim understands the difference between a sale maker and a real sailmaker.

Pineapple Sails is Tim Murison's sailmaker.

YOUR DEALER FOR: Musto foul weather gear, Dubarry footwear and Headfoil 2

Sails in need of repair may be dropped off at:  
West Marine in Oakland, Alameda, or Richmond;  
or Svendsen's in Alameda.

\*Powered by Pineapples



## PINEAPPLE SAILS

Phone (510) 522-2200

Fax (510) 522-7700

[www.pineapplesails.com](http://www.pineapplesails.com)

2526 Blanding Ave., Alameda, California 94501

# BOAT LOANS

*from*



Trident Funding

*"a fresh  
approach  
from people  
you can trust"*

*In Northern California call  
JOAN BURLEIGH  
(800) 690-7770*

*In Southern California call  
JEFF LONG  
MARGE BROOKSHIRE  
(888) 883-8634*

*In San Diego call  
MIKE LOCKARD  
(619) 255-5666*

[www.tridentfunding.com](http://www.tridentfunding.com)

## CONTENTS

subscriptions	6
calendar	10
letters	20
loose lips	70
sightings	72
master mariners	86
tahiti rendezvous	92
dear abby	100
delta ditch run	104
boatyard tour	110
pac cup preview	116
lee helm: squalls 101	120
the racing sheet	124
world of chartering	134
changes in latitudes	142
classy classified	160
advertisers' index	173
brokerage	175

Cover: The conditions couldn't have been more perfect for this year's Master Mariners Regatta, with just about every boat flying everything they had.

Photo: *Latitude 38/Andy*

Copyright 2010 Latitude 38 Publishing Co., Inc.

*Latitude 38* welcomes editorial contributions in the form of stories, anecdotes, photographs – anything but poems, please; we gotta draw the line somewhere. Articles with the best chance at publication must 1) pertain to a West Coast or universal sailing audience, 2) be accompanied by a variety of pertinent, in-focus digital images (preferable) or color or black and white prints with identification of all boats, situations and people therein; and 3) be legible. These days, we prefer to receive both text and photos electronically, but if you send by mail, anything you want back must be accompanied by a self-addressed, stamped envelope. **Submissions not accompanied by an SASE will not be returned.** We also advise that you not send original photographs or negatives unless we specifically request them; copies will work just fine. Notification time varies with our workload, but generally runs four to six weeks. Please don't contact us before then by phone or mail. Send all submissions to [editorial@latitude38.com](mailto:editorial@latitude38.com), or mail to Latitude 38 editorial department, 15 Locust Ave., Mill Valley, CA 94941. For more specific information, request writers' guidelines from the above address or see [www.latitude38.com/writers.html](http://www.latitude38.com/writers.html).

# What's new for the value minded sailor?



## Beneteau Oceanis 50

The Oceanis 50 features a sleek coachroof, long side windows, a fully integrated mainsheet arch that offers easy mainsheet handling, well positioned grab rails, an integral sprayhood and bimini, all the ergonomic ease of detailed design to

make the most of every space, and new eye-catching styling below decks.



## Beneteau First 30

Beneteau is launching the new FIRST 30, designed by the talented Juan Kouyoumdjian, well known from the America's Cup and Volvo Ocean Race. Go backstage with design teams and sailors on the First 30 blog:

[www.teamfirst30.com](http://www.teamfirst30.com)

## Island Packet Estero 36



### Island Packet's answer for the couple who wants:

- Relaxed cruising (Hoyt boom and furling jib)
  - Ultimate safety
- Go anywhere, comfortable local or long distance cruising
  - Premium quality and value

**NEW**

## Alerion Sport 33



### A New Daysailer from Alerion! New Sport 33:

- Lighter displacement
  - Asymmetrical headsail
    - Tiller
  - Carbon mast with Nitronic rigging
  - Infusion molded SCRIMP construction
- \$199,900**

## SELECT LISTINGS



Beneteau 423, 2005  
\$229,000



Island Packet 40, 1998  
\$225,000



Beneteau 393, 2003  
\$137,900



Island Packet 350, 1999  
\$169,000



Catalina 36  
Two from \$63,599



Island Packet 32, 1990  
\$89,000

### SAIL

50'	Chinese Junk	1972	\$325,000
47'	Beneteau 473	2006	324,000
46'	Beneteau 461	1998	SOLD 179,500
45'	Beneteau First 45f5	1991	157,500
43'	Gulfstar ctr. cockpit	1978	new listing 69,000
42'	Beneteau 423	2005	229,000
42'	Cascade	1971	52,500
41'	Tartan 4100	1996	229,000
40'	Beneteau First 40.7	2002	SOLD 159,000
40'	Island Packet	1998	225,000
40'	C&C 37+	1989	99,000
39'	Beneteau 393	2003	137,900
38'	Tartan 3800	1994	135,000
38'	Island Packet 380	1999	reduced 239,000
37'	C&C 37	1985	new listing 59,900
37'	Beneteau 373	2004	reduced 139,500
36'	Beneteau First 36.7	2002	118,000
36'	Island Packet 350	1999	169,000
36'	Catalina	2006	new listing 149,900
36'	Catalina	1988	63,500
36'	Pearson	1985	reduced 60,900
35'	Fantasia	1979	74,900
35'	J/109	2003	reduced 160,900
34'	Catalina 34 MkII	2006	pending 124,000
34'	Beneteau 343	2007	124,500
33'	Beneteau 331	2002	SOLD 85,900
32'	J/32	1997	97,500
32'	Island Packet	1990	89,000

### POWER

42'	Californian	1987	119,500
34'	Sea Ray 340	2006	159,000

## BENETEAU

Cruising: 31 34 37 40 43 46  
50 54 58

First Series: 30 35 36.7 40 45 50

## ISLAND PACKET

Estero 36 37 SP Cruiser 41  
460 465 485

## ALERION EXPRESS

28 29 33 38  
New Alerion Sport 33



1220 Brickyard Cove Rd  
Pt. Richmond, CA  
p: 510-236-2633  
f: 510-234-0118

[www.passageyachts.blogspot.com](http://www.passageyachts.blogspot.com) ▪ [www.passageyachts.com](http://www.passageyachts.com)

## BENETEAU

## ISLAND PACKET

## ALERION EXPRESS

1070 Marina Village Pkwy #101  
Alameda, CA  
p: 510-864-3000  
f: 510-337-0565



**TAYANA 48 DECK SALON**



**Tayana 54**  
**Tayana 58**  
**Tayana 64**  
**Tayana 72**



**2005 TAYANA 64 DECK SALON**  
 Beautiful, fully equipped, 4 state-room, 3 head vessel. **\$835,000**



**2005 TAYANA 48 CC**  
 Mexico vet. In great shape and loaded with everything you need. **\$469,000**



**1984 TAYANA 37**  
 This is the one you want. Perfect shape with lots of new upgrades.



**1988 FRASER 51 CUTTER**  
 Canadian-built center cockpit cutter. Great shape, ready to go again. **\$199,900**



**1997 TARTAN 4600**  
 Custom Kevlar reinforced hull. Beautifully maintained. **\$299,500**



**1984 TAYANA 42 AFT COCKPIT**  
 In great shape and ready to go! Many recent upgrades. **\$129,000**



**1979 BABA 30**  
 Traditional Bob Perry cruiser in 30 feet. Clean and ready to sail. **\$54,900**



**1974 CHEOY LEE MIDSHIPMAN**  
 Live aboard or cruise in this roomy CC ketch. 160 hours on 56hp Yanmar. **\$69,000**

**Pacific Yacht Imports**

[www.pacificyachtimports.net](http://www.pacificyachtimports.net)

Grand Marina • 2051 Grand St., Alameda, CA 94501  
 Tel (510) 865-2541 • [tayana@mindspring.com](mailto:tayana@mindspring.com)

# SUBSCRIPTIONS

Please read form carefully before submitting.

We regret that we cannot accept foreign subscriptions. Check, money order, or credit card information must accompany request. Please allow 4-6 wks to process changes/additions, plus delivery time.

eBooks email list. Free!



See [www.latitude38.com](http://www.latitude38.com) to download the entire magazine for free! Our eBooks are in PDF format, easy to use with Adobe Reader.

Email: \_\_\_\_\_

*NOTE: FPO/APO (military), Canada, Mexico, and subscriptions going to a correctional facility are first class only.*

- Enclosed \$36 for one year Third Class Postage (Delivery time 2-3 weeks; Postal Service will not forward third class; make address changes with us in writing.)
- Enclosed \$55 for one year First Class Postage (Delivery time 2-3 days.)
- Third Class Renewal     First Class Renewal **(current subs. only!)**
- Gift Subscription    Card to read from: \_\_\_\_\_

Name \_\_\_\_\_

Address \_\_\_\_\_

City \_\_\_\_\_

State \_\_\_\_\_

Zip \_\_\_\_\_

Phone: (    ) \_\_\_\_\_

Email: \_\_\_\_\_

**CREDIT CARD INFORMATION**

MASTERCARD

VISA

AMERICAN EXPRESS

Min. Charge \$12

Number: \_\_\_\_\_

Exp.: \_\_\_\_\_

csv: \_\_\_\_\_

**INDIVIDUAL ISSUE ORDERS**

Current issue = \$6.00 • With classy ad placed = \$5.00

Back Issues = \$7.00 (must indicate exact issue by month or vol. #)

**DISTRIBUTION**

- We have a marine-oriented business/yacht club in California which will distribute copies of *Latitude 38*. (Please fill out your name and address and mail it to the address below. Distribution will be supplied upon approval.)
- Please send me further information for distribution outside California

Business Name \_\_\_\_\_

Type of Business \_\_\_\_\_

Address \_\_\_\_\_

City \_\_\_\_\_

State \_\_\_\_\_

Zip \_\_\_\_\_

County \_\_\_\_\_

Phone Number \_\_\_\_\_

*Latitude 38*

"we go where the wind blows"

Publisher/Exec. Editor .....	Richard Spindler .....	<a href="mailto:richard@latitude38.com">richard@latitude38.com</a> .....	ext. 111
Associate Publisher .....	John Arndt .....	<a href="mailto:john@latitude38.com">john@latitude38.com</a> .....	ext. 108
Managing Editor .....	Andy Turpin .....	<a href="mailto:andy@latitude38.com">andy@latitude38.com</a> .....	ext. 112
Editor .....	LaDonna Bubak .....	<a href="mailto:ladonna@latitude38.com">ladonna@latitude38.com</a> .....	ext. 109
Racing Editor .....	Rob Grant .....	<a href="mailto:rob@latitude38.com">rob@latitude38.com</a> .....	ext. 105
Contributing Editors .....	John Riise, Paul Kamen		
Advertising Sales .....	John Arndt .....	<a href="mailto:john@latitude38.com">john@latitude38.com</a> .....	ext. 108
Advertising Sales .....	Shawn Grassman .....	<a href="mailto:shawn@latitude38.com">shawn@latitude38.com</a> .....	ext. 107
General Manager .....	Colleen Levine .....	<a href="mailto:colleen@latitude38.com">colleen@latitude38.com</a> .....	ext. 102
Production/Web .....	Christine Weaver .....	<a href="mailto:chris@latitude38.com">chris@latitude38.com</a> .....	ext. 103
Production/Photos .....	Annie Bates-Winship .....	<a href="mailto:annie@latitude38.com">annie@latitude38.com</a> .....	ext. 106
Bookkeeping .....	Jessie Mowry .....	<a href="mailto:jessie@latitude38.com">jessie@latitude38.com</a> .....	ext. 101

Directions to our office .....	press 4
Subscriptions .....	press 1,4
Classified .....	press 1,1
Distribution .....	press 1,5
Editorial .....	press 1,6
Calendar .....	
Other email .....	

Please address all correspondence by person or department name

15 Locust Avenue, Mill Valley, CA 94941 • (415) 383-8200 Fax: (415) 383-5816  
[www.latitude38.com](http://www.latitude38.com)



**Cruising Yachts, Inc.**

**Exclusive Dealer for Hunter, Jeanneau and Caliber Yachts**

**Save \$75,000 on the Hunter 50CC. Great Liveboard & Passagemaker!**



**New 2010 Model – Hunter 39**



**Award Winner! – Hunter 50CC**



**New Design – Jeanneau 42DS**



**New 2010 Model – Jeanneau 53**

**PRE CRUISED SPECIALS**

2006 Jeanneau 54 DS	\$549,000
2009 Jeanneau 50 DS	\$439,000
2008 Hunter 49	\$369,000
2006 Jeanneau 49 DS	\$375,000
2002 Hunter 466	\$219,000
2004 Hunter 466	\$217,900
2003 Hunter 466	\$219,000
1992 Catalina 45 CC	\$149,000
1999 Hunter 450	\$189,000
2008 Jeanneau 45 DS	\$318,500
1983 Morgan Nelson 45	\$109,000
2007 Beneteau 423	\$219,900
1997 Catalina 42 MKII	\$148,500
2005 Hunter 41 AC	\$185,000
1999 Hunter 410	\$129,000

**PRE CRUISED SPECIALS**

2008 Beneteau 40	\$199,000
1986 Beneteau 40.5	\$59,900
1997 Hunter 40.5	\$114,900
1993 Hunter 40.5	\$114,000
1980 Islander 40	\$69,900
2003 Beneteau 393	\$135,000
2006 Hunter 38	\$174,500
2000 Hunter 380	\$114,500
2004 Hunter 386 LE	\$130,500
2005 Sabre 386	\$270,000
1996 Hunter 376	\$85,000
1995 Hunter 37.5	\$72,000
1994 Jeanneau SO 37.1	\$85,000
1978 Tartan 37	\$39,995
1967 Tartan 37	\$35,000

**PRE CRUISED SPECIALS**

1995 Catalina 36 MKII	\$78,500
2007 Hunter 36	\$149,995
1994 Hunter 35.5	\$59,900
2004 Jeanneau 35	\$114,995
2004 Jeanneau 35	\$109,990
1979 C&C Sloop 34	\$29,500
1989 Catalina 34	\$48,500
1995 Hunter 336	\$59,000
2001 Hunter 320	\$54,900
2003 Hunter 326	\$59,900
1990 Hunter 32	\$38,500
2007 Hunter 31	\$89,900
1988 O'Day 302	\$24,900
2001 Hunter 290	\$49,900

**San Diego**  
(619) 681-0633

**Newport Beach**  
(949) 650-7245

**Alameda**  
(510) 521-5544

**Marina del Rey**  
(310) 822-9400

**Oxnard**  
(805) 791-2082

**www.CruisingYachts.net**

# Yachtfinders/Windseakers

in the heart of  
San Diego's boating community

2330 Shelter Island Dr. # 207, San Diego, CA 92106

info@yachtfinders.biz

(619) 224-2349

Toll Free (866) 341-6189

Go to  
[www.yachtfinders.biz](http://www.yachtfinders.biz)  
for all our 80+ listings!



**65' ALDEN, '52**      **\$1,200,000**  
Purchased by her current owners in 2003, brought to San Diego for complete refit. New custom interior, all mechanicals modernized.



**55' JOMAR CENTER COCKPIT, '83**      **\$269,000**  
This strong, graceful cruiser has been recently upgraded with new engine and electronics specifically for a trip to Mexico and back.



**50' CHEDY LEE ALDEN OFFSHORE, '70**      **\$199,000**  
This wonderful design is an absolute joy to sail. Easily handled by two, and by some single-handed. Below decks, she's light and bright.



**48' CUSTOM CELESTIAL CC, '86**      **\$237,500**  
*Reba* is a highly customized 48' Celestial center cockpit ketch that has been extremely well maintained by knowledgeable cruisers.



**42' VALIANT 42 CE, '97**      **\$318,000**  
Designed for the discerning yachtsman/cruiser, the Valiant 42 is one of the quintessential cruisers of all time. Exquisite finish work.



**42' MULL, '85**      **\$140,000**  
Preparing for sale, she's undergoing a complete detailing including US-friendly 110V electrics and fresh varnish down below.



**42' CATALINA 2-CABIN PULLMAN, '92**      **\$125,000**  
The C42 is acknowledged to be one of the best models built by the most prolific boat building company in the world, and for good reason.



**41' MORGAN OUT ISLAND 415 CC, '78**      **\$78,900**  
This boat has had all the 20-year projects done: standing rigging/turnbuckles replaced, newer sails, new through-hulls, new portlights.



**39' CAVALIER, '76**      **\$59,400**  
Cavaliers were designed and built for cruising in the demanding conditions of the Tasman Sea – some of the roughest waters in the world.



**34' TIFFANY JAYNE, '83**      **\$49,000**  
*Dancer* is an exceptional boat combining a high performance underbody with the low, elegant lines of a more traditional sailing yacht.



**30' ISLANDER BAHAMA, '80**      **\$24,900**  
Affordable coastal cruiser for the first-time buyer and great family boat for learning sailing and water safety. Reliable diesel engine.



**28' SCHUMACHER, '00**      **\$34,000**  
This is an opportunity to own a pocket rocket at a very affordable price and bring home some pickle dishes. Her NorCal PHRF is 126.



Ray Watson & Jeannette Sarrasin  
Toll free US/CAN: 1 (888) 716-7430  
Phone & FAX: 011 52 (669) 913-3165  
E-mail: Mazmarine@aol.com



Mike Rickman & Shelly R. Ward  
Toll free US/CAN: 1 (877) 245-9689  
Phone & FAX: 011 52 (612) 123-1948  
E-mail: LaPazYachts@aol.com



[www.yachtworld.com/mazmarine](http://www.yachtworld.com/mazmarine)



**56' GRADY MARLINEER Sportfisher** 1965, Beautiful...**\$229,000**



**55' OCEAN Sportfisher**, 1985...**\$499,000**



**51' & 45' ISLAND TRADER Ketch**, 1974 & 1979...**\$124,900**



**38' PEARSON 385 CC**, 1986...**\$69,900**

**8 BOATS UNDER \$30k**

Check out all listings at  
[www.mazmarine.com](http://www.mazmarine.com)



**36' CATALINA MkII Sloop**...2 to pick from.



**34' CAL Sloop**, 1969...**\$28,000**



**32' BRISTOL Yawl**, 1978...**\$29,900**



**29' HUNTER Sloop**, 2001...**\$54,950**

**PV YACHTS RE-OPENING SOON IN PUERTO VALLARTA • CALL TO LIST (888) 716-7430**



San Francisco's yacht broker since 1969 ~ celebrating our 40th year!

# Cityyachts YACHTS AND THE CITY



Beneteau 370, 1991 \$79,000



Hunter 356, 2003 \$94,900



33' Hunter Sloop, 1980 \$35,000



Cal 39, 1979 \$59,900



Alerion 28, 1999 \$68,500



Hinterhoeller 26C Nonsuch, 1981 \$32,000



46' Moody, 2000 \$397,000



Newport 30 MkIII, 1982 \$26,000



30' Cape Dory, 1978 \$32,500

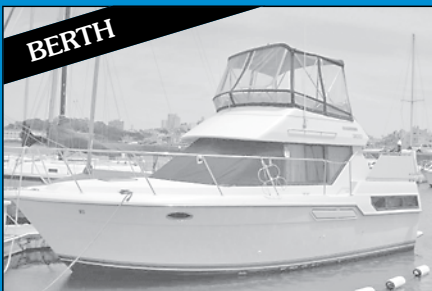

Carver 30, 1993 \$59,900



47' Chris Craft Commander, '74 \$122,000



28' Bayliner 2855, 2000 Make an offer

10 MARINA BL. • SAN FRANCISCO, CA 94123 • Toll Free: 877-444-5091 • 415-567-8880  
FAX (415) 567-6725 • email: sales@citysf.com • website: www.citysf.com



PLEASE VISIT OUR FUEL DOCK AT GASHOUSE COVE MARINA • OPEN 7 DAYS A WEEK • 9AM TO 5PM

# Ranger Trailerable Tugs can take you anywhere you want to go.



Looking to expand your experience on the water? Look no further than Ranger Tugs' easy-to-own, easy-to-operate power yachts you can even trailer. Designed and built in the U.S., Ranger's comfortable, compact designs are fast, fuel efficient and packed with features.

Come visit Farallone Yacht Sales of Alameda and check out Ranger's Bristol Bay-inspired R-21 trawler, and see the new R-25SC and the powerful R-29, both with standard bow and stern thrusters to enhance maneuverability. Farallone Yacht Sales, Inc., is the exclusive Bay Area dealer for Ranger Tugs, a family-owned company designing and building quality boats since 1958.

## Come walk our docks! Open Boat Weekend July 9, 10, 11

### New Ranger Tugs in Stock\*

Ranger 29 Tug, 2010 .....	\$224,937
Ranger 25 Tug, 2010 .....	139,937
Ranger 25-SC Tug, 2010.....	129,937
Ranger 21 Tug, 2010 .....	49,937

\*Base price

### Preowned Ranger Tugs at Our Docks

Ranger 29 Tug, 2009 .....	\$229,000
Ranger 25 Tug, 2009 .....	139,000



F A R A L L O N E

Alameda (510) 523-6730  
Newport Beach (949) 610-7190  
San Diego (619) 523-6730

[www.faralloneyachts.com](http://www.faralloneyachts.com)

# CALENDAR

## Non-Race

**July 1** — Linehandling seminar by Jim Hancock at San Carlos West Marine, 6-7:30 p.m. Info, (650) 593-2070.

**July 1-3, 8, 10, 15-16, 22, 24, 29-31** — Sail aboard San Francisco Maritime National Historic Park's scow schooner *Alma*. Learn the Bay's history on this 3-hour voyage, leaving Hyde St. Pier at 1 p.m. \$40 adults, \$20 kids 6-15. Info, [www.nps.gov/safr](http://www.nps.gov/safr).

**July 4** — Aeolian YC Open House & BBQ. No suit and tie required! Info, [www.aeolianyc.com](http://www.aeolianyc.com).

**July 4** — Celebrate Independence Day at Barron Hilton's Fireworks Extravaganza at Mandeville Tip in the Delta.

**July 4-25** — Free sailing at Pier 40 every Sunday courtesy of BAADS. Info, (415) 281-0212 or [www.baads.org](http://www.baads.org).

**July 4, 25** — Cal Sailing Club's free introductory sail at Berkeley Marina, 1-4 p.m. Info, [www.cal-sailing.org](http://www.cal-sailing.org).

**July 7-28** — Wednesday Yachting Luncheon Series at St. Francis YC, 12-2 p.m., \$13.50. Enjoy lunch and a dynamic speaker every Wednesday. All YCs' members welcome. More info under the 'Events' tab at [www.stfy.com](http://www.stfy.com).

**July 8** — Single sailors of all skill levels are invited to the Single Sailors Association monthly meeting at Ballena Bay YC, 7:30 p.m. Info, [www.singlesailors.org](http://www.singlesailors.org) or (510) 233-1064.

**July 8, Aug. 12** — Fishing Seminar Series at San Carlos West Marine, 6-7 p.m. Free. Info, (650) 593-2070.

**July 9-11** — 28th Catalina Yachts Rendezvous at Two Harbors, Catalina Island. Info, [www.catalinayachts.com](http://www.catalinayachts.com).

**July 15** — Stitch & glue boatbuilding demonstration at Fiberglass Supply in Burlington, WA, 6-8 p.m. Info, (877) 493-5333 or [www.fiberglasssupply.com](http://www.fiberglasssupply.com).

**July 15** — Cruising SF Bay & the Delta seminar at San Carlos West Marine, 6-7:30 p.m. Info, (650) 593-2070.

**July 16-18** — Annual Catalina Owners Rendezvous at Tradewinds Sailing School in Marina Bay. All Catalinas welcome! Info, <http://raft.c380.org>.

**July 17** — Glen Cove Marina Jazz, Wine & Arts Festival, noon-dusk. Info, [www.glencovemarina.net](http://www.glencovemarina.net).

**July 18** — Sailing Speaker Series with Yoga. Julie Lucchesi will discuss how sailing improved her life on land, 10 a.m.-noon at Bow Yoga Studio in San Rafael. \$30 for seminar, plus yoga and meditation classes. Info, (510) 333-8846.

**July 24** — Charter Share Party at Alameda Club Nautique, 6-8 p.m. Come meet like-minded sailors to share boat charters. Info, (510) 865-4700 or [www.clubnautique.com](http://www.clubnautique.com).

**July 24** — USCGA Boating Safety Course at San Jose West Marine, 10 a.m.-2 p.m. \$20, includes lunch. Space limited. Reservations, (408) 246-1147.

**July 24** — 10th Annual Women's Sailing Clinic at Lake Tahoe, for beginning to advanced sailors. \$65 members, \$75 non-members. LTWYC, [www.tahoewindjammers.com](http://www.tahoewindjammers.com).

**July 24** — Summer Water Festival at San Rafael YC, 1-5 p.m. Sailing & kayak demos, games, BBQ, live music and more. Info, [summerfest@sanrafaelyachtclub.org](mailto:summerfest@sanrafaelyachtclub.org).

**July 25** — Howl at the full moon on a Sunday night.

**July 31-Aug. 6** — *Latitude 38's* Delta Doo Dah Deux, a laid-back rally to the balmy Delta waters. Follow the event at [www.deltadoodah.com](http://www.deltadoodah.com).

**July, 1980** — It Was Thirty Years Ago, from the *Sightings* piece 'webb chiles is still alive':

Ever since Webb Chiles departed San Diego on his latest sailing extravaganza, sailors have been waiting for it to end in disaster. While the voyage hasn't completely terminated, it most certainly has been interrupted by misfortune.

Chiles, you may remember is the gentleman who sailed

# Catalina 445

## Sweeps



## 2010 Awards

For more than 35 years, Farallone Yachts has been known for superior product knowledge, unparalleled service and exceptional customer satisfaction. Our staff is comprised of avid and accomplished sailors, cruisers, and racers with more than 100 years of collective sailing expertise and experience right here in the Bay Area.

In addition to our retail line of award-winning Catalina yachts and Ranger tugs, we have a well-earned reputation for value and variety in brokerage boats.

Farallone Yacht Sales, Inc., is the exclusive Bay Area dealer for Catalina Yachts, the largest privately owned and operated manufacturer of U.S.-built sailing yachts in the world.



Best Full-Sized Cruiser



Best Cruising Monohull Under 50 ft.

**Calling all Catalinas!**  
**2010 Catalina Island Rendezvous**  
 July 9-11  
[www.catalinayachts.com](http://www.catalinayachts.com)  
**2010 S.F. Bay Rendezvous**  
 July 16-18  
<http://raft.c380.org>

### BOATS ARE SELLING • LIST WITH US • MORE THAN 65 BOATS SOLD IN 2009!

#### New Catalina Yachts in Stock

- Catalina 445, 2010
- Catalina 375, 2010

#### Preowned Catalina Yachts at Our Docks

Catalina 42, 1993	\$128,500
Catalina 400, 2008	269,000
Catalina 400, 2001	179,000
Catalina 400, 1997	139,500
Catalina 387, 2004	160,000
Catalina 38, 1982	42,500
Catalina 36, 2005	129,000
Catalina 36, 1987	49,500
Catalina 36, 1983	37,000
Catalina 350, 2004	144,500
Catalina 350, 2005	149,000
Catalina 350, 2004	127,500
Catalina 350, 2008	169,500

Catalina 34, 2007	134,500
Catalina 34, 2004	118,500
Catalina 34, 1997	75,500
Catalina 320, 2004	115,000
Catalina 320, 2002	84,000
Catalina 320, 1999	83,750
Catalina 310, 2007	104,000

#### Preowned Sailing Yachts at Our Docks

Dufour 48, 1995	\$175,000
Hunter 46, 2004	209,500
Hunter 46, 2000	219,500
Hunter 45, 2007	279,000
Cavalier 45, 1985	199,500
Morgan 45, 1992	149,000
Hunter 44, 2007	249,000
Jeanneau 43, 2002	225,000
Hunter 42, 1994	134,500

Fair Weather 39, 1985	119,900
Hunter 37, 1987	61,500
Hunter 36, 2007	139,000
Hunter 36, 2004	119,000
Islander 36, 1977	39,900
Hunter 35.5, 1993	59,000
Hunter 31, 2000	39,900

#### New Ranger Tugs in Stock\*

Ranger 29 Tug, 2010	\$224,937
Ranger 25 Tug, 2010	139,937
Ranger 25-SC Tug, 2010	129,937
Ranger 21 Tug, 2010	49,937

\*Base price

#### Preowned Ranger Tugs at Our Docks

Ranger 29 Tug, 2009	\$229,000
Ranger 25 Tug, 2009	139,000



F A R A L L O N E [www.faralloneyachts.com](http://www.faralloneyachts.com)

1070 Marina Village Pkwy  
 Alameda, CA 94501  
 (510) 523-6730

2801 West Coast Hwy  
 Newport Beach, CA 92663  
 (949) 610-7190

2353 Shelter Island Dr  
 San Diego, CA 92106  
 (619) 523-6730



**MOORINGS 43**



1986 BENETEAU, \$69,500

**TAYANA DS 48**



2003, \$439,000

**51' FORMOSA**



1979, \$85,000

**33' NONSUCH**



1989, \$111,900

**NORWEST 33**



1979, \$35,000

**32' WESTSAIL**



1974. Perfect! \$74,900

**C&C 41**



1984, \$73,000

**GULFSTAR 50**



1978, price TBA

**45' JOURNEY LRCA**

Wave Piercing Bows  
High Cruising Speeds  
3+ km/gal. at 15 knots  
2 or 3 staterooms  
Proven Offshore Design  
[journey@bayislandyachts.com](mailto:journey@bayislandyachts.com)  
<http://journeycatamarans.com>



In Grand  
Marina

**(510) 814-0400**

Fax (510) 814-8765  
2099 Grand Street, Alameda, CA 94501  
[www.bayislandyachts.com](http://www.bayislandyachts.com)  
[yachtsales@bayislandyachts.com](mailto:yachtsales@bayislandyachts.com)

**YACHTWORLD.com**



# CALENDAR

his Ericson 37 to a singlehanded circumnavigation in 1975-76. The *Guinness Book of World Records* credits his 202-day passage as the world record for solo circumnavigation in a monohull.

Webb Chiles, however, is not one to rest on his laurels, and left San Diego a year ago December to do another solo circumnavigation, this one in *Chidiok Tichborne*, an 18-ft open boat. That's pretty radical stuff, and you couldn't help wondering if it was subconscious suicide. Few people would have been surprised if he was never heard from again.

For 6,000 ocean miles to Suva, everything went as well as could be expected in a small open boat, but on May 10, *Chidiok* hit an object in the water, pitched, and filled with water. Losing everything, Chiles scrambled into his inflatable dinghy and tied onto the open boat, which remained awash. For the next two weeks, he feasted on a few crackers, part of a packet of freeze-dried food, and a few sips of water.

Eventually he washed up on a reef in the New Hebrides, dragged the inflatable across the reef and paddled to the beach, and eventually got to a hospital. Personal injuries were limited to an injured foot and loss of weight. *Chidiok* finally washed up on the beach also.

As you might assume, Webb is not about to give up. He'll gather supplies and repair equipment in New Zealand, fix the boat, then it's off to Port Moresby, New Guinea, where he was heading before being so rudely interrupted.

**Aug. 5** — Anchoring seminar by Jim Hancock at San Carlos West Marine, 6-7:30 p.m. Info, (650) 593-2070.

**Aug. 5-7** — Beneteau Owners Rendezvous at Catalina's Two Harbors. Info, [www.southwesternyachts.com](http://www.southwesternyachts.com).

**Aug. 7** — Ballena Bay YC's Island Party featuring Eric Stone. Dinner \$35, music only \$10. Info, (510) 523-2292.

**Aug. 7** — 30th Anniversary Flea Market & Maritime Celebration at Galilee Harbor in Sausalito, 8 a.m.-6 p.m. Info, (415) 332-8554 or [www.galileeharbor.org](http://www.galileeharbor.org).

**Aug. 10** — Community Day at San Carlos West Marine with 5% of sales going to the Leukemia & Lymphoma Society. Info, (650) 593-2070.

**Aug. 10-Oct. 5** — America's Boating Course by San Luis Rey USPS at Oceanside YC on Tuesday nights, 6-9 p.m. Space limited, \$65 fee. Info, (760) 729-6034.

**Aug. 15** — Sailing Speaker Series with Yoga. Jennifer McKenna will discuss how she challenges herself regularly, 10 a.m.-noon at Bow Yoga Studio in San Rafael. \$30 for seminar, plus yoga and meditation classes. Info, (510) 333-8846.

## Racing

**July 3** — 62nd Annual Boreas Race, Half Moon Bay to Moss Landing. Elkhorn YC and HMBYC, [www.elkhornyc.com](http://www.elkhornyc.com).

**July 3-4** — 43rd Marina del Rey to San Deigo Race. Info, [www.smwyc.org](http://www.smwyc.org) or [www.southwesternyc.org](http://www.southwesternyc.org).

**July 4** — Brothers & Sisters Regatta, a low-key lap around the two island groups followed by a BBQ and shoreside fun for the whole family. TYC, [www.tyc.org](http://www.tyc.org).

**July 5** — First start of the 16th Biennial Fun Race to Hawaii, aka the Pacific Cup. For details on the race, visit [www.pacificcup.org](http://www.pacificcup.org).

**July 9-11** — TransTahoe/Melges Regatta, generally featuring either too much wind or too little but always lots of fun. Tahoe YC, [www.tahoeyc.com](http://www.tahoeyc.com).

**July 10** — YRA Spring #3. YRA, [www.yra.org](http://www.yra.org).

**July 10** — Silver Eagle Long Distance In-The-Bay Race, with a shorter course for boats rating 150 or above. IYC, contact John New at [racing@iyc.org](mailto:racing@iyc.org) or [www.iyc.org](http://www.iyc.org).

# THE BOAT YARD AT GRAND MARINA

"Where Service Has Meaning"

**Interlux.**  
yachtpaint.com

**AWLGRIP**

**60-TON  
TRAVELIFT**



FEATURING  
TRINIDAD  
ANTI-FOULING PAINT BY  
**PETTIT**  
Go clean into the future.  
RATED "SUPERIOR" by  
Practical Sailor

Official  
Sponsor  
2010  
**BAJA  
HA-HA**

*The only yard to brush  
on your bottom paint!*

Dealers for:

**MAX-PROP**  
AUTOMATIC FEATHERING PROPELLERS

**GORI**  
marine

**Webasto**

PACLESS SEALING SYSTEM  
**SHAFT SEAL**

**LECTRA/san**

**SIDE-POWER**  
Thruster systems

**facnor**  
FURLING SYSTEMS INC.

**AQUAMARINE**  
FINE REVERSE OSMOSIS EQUIPMENT

## IT'S SIMPLE!

Call The Boat Yard at Grand Marina for the Lowest Bottom Prices!

~ COMPARE US WITH THE COMPETITION ~

- Prop and Shaft Work
- Mast & Rigging Repair
- Fiberglass & Blister Repair
- Gelcoat Repair
- Gas & Diesel Engine Service
- LPU Hull & Topside
- Electrical Repair & Installation

**CALL FOR A RESERVATION**

(510) 521-6100 • Fax (510) 521-3684

Located at Grand Marina • 2021 Alaska Packer Place, Alameda

[www.boatyardgm.com](http://www.boatyardgm.com)

# WARMINGTON RESIDENTIAL

CALIFORNIA



W

## A Waterfront Community Just Steps from Grand Marina



Adjacent to Grand Marina at the estuary end of Grand Street, this picturesque community offers views of Oakland and Coast Guard Island and is set just minutes from Park Street near downtown Alameda shopping and restaurants. **This is a very**

**special location that is just steps from the water** and all of the boat slips and related marine services of Grand Marina, presenting a remarkable lifestyle opportunity.

- Charming Three Level Craftsman and Cottage-Style Homes
- 2,152 to 2,373 square feet
- 4 Bedrooms plus bonus room/tech loft, per plan
- 3.5 Baths
- 2-space garages

PRICED FROM THE **upper \$600,000s** TO **lower \$800,000s**



1629 Cruiser Lane, Alameda | t. 510.814.6535  
Sales representatives: Beth Costello, DRE Lic 00858354  
Debi Garlick, DRE Lic 00801442

HOMES**by** WARMINGTON .com



Realtors® welcome.



Prices effective date of publication and subject to change prior to sale.  
05.21.10

# CALENDAR

- July 10** — Jack & Jill Race. SSC, [www.stocktonsc.org](http://www.stocktonsc.org).  
**July 10** — H.O. Lind #5 & 6. TYC, [www.tyc.org](http://www.tyc.org).  
**July 10** — Hart Nunes for Mercs. SFYC, [www.sfyf.org](http://www.sfyf.org).  
**July 10-11** — BAYS #3/Svendson's Summer Splash (which also acts as the Area G Smythe qualifier) at EYC. Info, [www.bayarea-youthsailing.com](http://www.bayarea-youthsailing.com).  
**July 10-11** — High Sierra Regatta for Centerboard Classes. Info, [www.fresnoyachtclub.org](http://www.fresnoyachtclub.org).  
**July 10-11** — Longboard SF Classic/UN Challenge. StFYC, [www.stfyf.com](http://www.stfyf.com).  
**July 10-11** — Monterey Bay PHRF Championships. MPYC, [www.mpyc.org](http://www.mpyc.org).  
**July 16-18** — Finn NAs. SFYC, [www.sfyf.org](http://www.sfyf.org).  
**July 17** — Angel Isl./Red Rock Race. VYC, [www.vyc.org](http://www.vyc.org).  
**July 17** — 26th Annual Plastic Classic Regatta & Concours d'Elegance, for fiberglass boats from the '60s & '70s. BVBC, [www.plasticclassic.com](http://www.plasticclassic.com) or (415) 864-4334.  
**July 17** — Summer #4. SeqYC, [www.sequoiayc.org](http://www.sequoiayc.org).  
**July 17-18** — US Sailing Match Racing Semi-Finals. StFYC, [www.stfyf.com](http://www.stfyf.com).  
**July 17-18** — High Sierra Regatta for Keelboat Classes. Info, [www.fresnoyachtclub.org](http://www.fresnoyachtclub.org).  
**July 17-18** — Moseley Regatta. TYC, [www.tyc.org](http://www.tyc.org).  
**July 17-18** — PICYA Lipton Cup, the annual interclub all-star game. GGYC, [www.picya.org](http://www.picya.org).  
**July 18** — Summer Series #2 (FJs) on Fremont's Lake Elizabeth. Info, [www.fremontsailingclub.org](http://www.fremontsailingclub.org).  
**July 19-25** — Golden Gate Cup. GGYC, [www.ggyc.org](http://www.ggyc.org).  
**July 20-24** — US Windsurfing National Championship and Formula NAs. StFYC, [www.stfyf.com](http://www.stfyf.com).  
**July 24** — Midnight Moonlight Maritime Marathon, a night run from Raccoon Strait to Carquinez Strait and back. SFYC, [www.sfyf.org](http://www.sfyf.org).  
**July 24** — Summer #4. Oyster Point YC, [www.opyc.com](http://www.opyc.com).  
**July 24** — North Bay Challenge #4. VYC, [www.vyc.org](http://www.vyc.org).  
**July 24** — West Wight Potters Roundup on Monterey Bay. MPYC, [www.mpyc.org](http://www.mpyc.org).  
**July 24-25** — YRA 2nd Half Opener. EYC, [www.yra.org](http://www.yra.org).  
**July 24-25** — J/24 District Races on Lake Pend Oreille in Sandpoint, ID. Info, [www.sandpointsailing.com](http://www.sandpointsailing.com).  
**July 30** — Jake's Regatta on North Lake Tahoe. Tahoe YC, [www.tahoeyc.com](http://www.tahoeyc.com).  
**July 30-Aug. 1** — Aldo Alessio Perpetual for IRC, J/120s, J/105s and any other big boat one design class that fields six boats. StFYC, [www.stfyf.com](http://www.stfyf.com).  
**July 30-Aug. 1** — Santana 22 Nationals. EYC, [www.encinal.org](http://www.encinal.org).  
**July 31** — YRA-OYRA Lightship 2. GGYC, [www.yra.org](http://www.yra.org).  
**July 31** — Singlehanded #3. SeqYC, [www.sequoiayc.org](http://www.sequoiayc.org).  
**July 31** — Small Boat Summer Series #1. EYC, [www.encinal.org](http://www.encinal.org).  
**July 31** — McNish Classic, for classics designed before 1952, held in the Channel Islands. PCYC, [www.pcyc.org](http://www.pcyc.org).  
**July 31-Aug. 1** — 505 Regatta. SFYC, [www.sfyf.org](http://www.sfyf.org).  
**Aug. 1** — Women's Day Race on Lake Tahoe. LTWYC, [www.windjammers.com](http://www.windjammers.com).  
**Aug. 1** — Summer Series #3 (FJs) on Fremont's Lake Elizabeth. Info, [www.fremontsailingclub.org](http://www.fremontsailingclub.org).  
**Aug. 7** — YRA Fall #1. RYC, [www.yra.org](http://www.yra.org).  
**Aug. 7-8** — H.O. Lind #7 & 8. TYC, [www.tyc.org](http://www.tyc.org).  
**Aug. 7-8** — El Toro Worlds at Pinecrest. Info, [www.el-toro.org](http://www.el-toro.org).  
**Aug. 7-14** — International Knarr Championship. StFYC, [www.stfyf.org](http://www.stfyf.org).  
**Aug. 8** — Gracie & George Regatta, a co-ed doublehanded

# Remember when service actually meant something?



## FREE SAIL INVENTORY EVALUATION

Bring your sails in to Quantum  
today for a free evaluation,  
and be ready to go this summer.



TM

**Quantum Pacific**  
1230 Brickyard Cove Road  
Point Richmond, CA 94801  
[sanfrancisco@quantumsails.com](mailto:sanfrancisco@quantumsails.com)  
510.234.4334

# STEP ABOARD

at our dock

# SC<sup>37</sup>

Santa Cruz  
YACHTS



Fast Is Fun!

## SCORCHING SPEED! Plus:

Easier to sail, easier to manage.

Efficient design means smaller offshore crews to Mexico or Hawaii. Try it.

Call for a test sail... and hold on tight!



J/111

If you love to go sailing, you'll love this new 36-ft speedster. She's a pleasure daysailing, weekendng, or racing.



Summit 35

An already successful, just launched, dual-purpose IRC cruiser-racer, and all-around performer.

# SAIL

California

Alameda  
(510) 523-8500  
norman@sailcal.com  
steve@sailcal.com

www.sailcal.com • www.santacruzayachts.com

## CALENDAR

featuring 'Gracie' on the helm. EYC, [www.eyc.org](http://www.eyc.org).

**Aug. 14** — YRA-OYRA Northern Star. Info, [www.yra.org](http://www.yra.org).

**Aug. 14** — North Bay Challenge #5. VYC, [www.vyc.org](http://www.vyc.org).

**Aug. 14** — Tri-Island Race around Treasure Island, Alcatraz and Red Rock. RYC, [www.richmondyc.org](http://www.richmondyc.org).

**Aug. 14** — Delta Dinghy Ditch Run, from Rio Vista to West Sac. LWSC, [www.lwsailing.org](http://www.lwsailing.org).

**Aug. 14-15** — BAYS Summer Series #4 for Optimis, Lasers, C420s & CFJs. SFYC, [www.bayarea-youthsailing.com](http://www.bayarea-youthsailing.com)

**Aug. 14-15** — Summer Keel. SFYC, [www.sfyc.org](http://www.sfyc.org).

**Aug. 15** — Baxter Judson #5. PresYC, [www.presidioyachtclub.org](http://www.presidioyachtclub.org).

**Aug. 28** — Great San Francisco Schooner Race, for schooners in Gaff and Marconi divisions. SFYC, [www.sfyc.org](http://www.sfyc.org).

### Summer Beer Can Regattas

**BALLENA BAY YC** — Friday Night Grillers: 7/9, 7/23, 8/6, 8/20, 9/3. Info, (925) 785-2740 or [race@bbyc.org](http://race@bbyc.org).

**BAY VIEW BOAT CLUB** — Monday Night Madness Fall: 7/26, 8/9, 8/23, 9/6, 9/20, 9/27 (make-up). Arjan Bok, (415) 864-4334 or [bayviewracing@sbcglobal.net](mailto:bayviewracing@sbcglobal.net).

**BENICIA YC** — Thursday nights: 7/8-8/26, 9/9-9/30. Grant Harless, (510) 245-3231 or [harlessgrant@sbcglobal.net](mailto:harlessgrant@sbcglobal.net).

**BERKELEY YC** — Every Friday night through 9/24. Bobbi, (925) 939-9885 or [bobbi\\_john@jfcbat.com](mailto:bobbi_john@jfcbat.com).

**CAL SAILING CLUB** — Year-round Sunday morning dinghy races, intraclub only, typically in Laser Bahias and JY15s. Email Gary and Alistair at [racing\\_chair@cal-sailing.org](mailto:racing_chair@cal-sailing.org).

**CORINTHIAN YC** — Every Friday night through 9/3. Donal Botkin, (415) 497-5411 or [racing@cyc.org](mailto:racing@cyc.org).

**COYOTE POINT YC** — Every Wednesday night through 10/27. Torin Knorr, (650) 863-2570 or [regatta@cpyc.com](mailto:regatta@cpyc.com).

**ENCINAL YC** — Friday Night Summer Twilight Series: 7/16, 7/30, 8/13, 8/27, 9/17. Victor Early, (510) 708-0675 or [rearcommadore@encinal.org](mailto:rearcommadore@encinal.org).

**FOLSOM LAKE YC** — Every Wednesday night through 7/7 & 7/21-9/22. Info, [www.flyc.org](http://www.flyc.org).

**GOLDEN GATE YC** — Friday nights: 7/9, 7/16, 7/30, 8/13, 8/27. Mont McMillen, (209) 481-5158 or [ggycrace@comcast.net](mailto:ggycrace@comcast.net).

**ISLAND YC** — Friday Summer Island Nights: 7/23, 8/6, 8/20, 9/10, 9/24. John New, (510) 521-2980 or [iycracing@yahoo.com](mailto:iycracing@yahoo.com).

**LAKE TAHOE WINDJAMMERS YC** — Every Wednesday night through 10/13. Pete Russell, (775) 721-0499.

**LAKE WASHINGTON SC** — Every Thursday night through 8/26. Roy Pitts, (530) 908-7160 or [rpitts@ucdavis.edu](mailto:rpitts@ucdavis.edu).

**LAKE YOSEMITE SA** — Every Thursday night through August. Steve Eyberg, [seyberg505@sbcglobal.net](mailto:seyberg505@sbcglobal.net).

**MONTEREY PENINSULA YC** — Sunset Series, every Wednesday night through 9/29. Ray Ward, (831) 659-2401.

**OAKLAND YC** — Sweet 16 Series, every Wednesday night: 7/28-9/15. John Tuma, (510) 366-1476 or [j\\_tuma@comcast.net](mailto:j_tuma@comcast.net).

**RICHMOND YC** — Wednesday nights: 7/7, 7/14, 7/28, 8/4, 8/11, 8/18, 8/25, 9/1, 9/15, 9/22, 9/29. Eric Arens, (510) 841-6022 or [ericarens@comcast.net](mailto:ericarens@comcast.net).

**ST. FRANCIS YC** — Weds. Night Series: 8/4-8/25. Thursday Night Kiting Series: 7/15, 7/29, 8/12, 8/26, 9/6, 9/23. Friday Night Windsurfing Series: 7/16, 7/30, 8/13, 8/27, 9/10, 9/24. John Craig, (415) 563-6363 or [racemgr@stfyc.com](mailto:racemgr@stfyc.com).

**SANTA CRUZ YC** — Wet Wednesdays through 11/3. Greg Haws, (831) 425-0690 or [greg@scyc.org](mailto:greg@scyc.org).

**SAUSALITO YC** — Tuesday Night Summer Sunset Series: 7/27, 8/10, 8/24, 9/7, 9/21. John Mount, (415) 509-8381 or [race@syconline.org](mailto:race@syconline.org).



# SAIL *California*

## YOUR PERFORMANCE YACHT SPECIALISTS

### ALAMEDA

1070 Marina Village Pkwy #108  
Alameda, CA 94501  
**(510) 523-8500**  
FAX (510) 522-0641

### SEATTLE

**SAIL NORTHWEST**  
7001 Seaview Ave. NW #140  
Seattle, WA 98117  
**(206) 286-1004**



**Beneteau First 42, 1984, Blarney**  
Well equipped performance cruiser.  
Asking **\$89,000**



**Santa Cruz 52, 1998, Hula**  
Deep draft for cruising, buoy and offshore.  
This boat has it all. Reduced to **\$495,000**



**J/122, TKO**  
Ready to win the Big Boat Series again!  
Asking **\$469,000**



**True North 38, Zest**  
Like new, low hours, the perfect picnic boat.  
Asking **\$375,000**



**Kernan 44, Wasabi**  
Turn key race winner.  
Asking **\$429,000**



**J/124, 2007, Fortuna**  
For the joy of sailing, experience the J/124.  
Reduced to **\$279,000**



**J/32, 2002, Tango**  
Well maintained and equipped.  
Asking **\$119,000**



**J/105, 2002, Grace O'Malley**  
We have six J/105s from **\$83,000**



**1D35, Great Sensation**  
Total refit inside and out.  
Asking **\$84,900**



**Custom Wylie 42, 1991, Scorpio**  
Proven winner, race ready.  
Asking **\$169,000**

77' Andrews, '03* .....\$799,000	40' X-119, '89* .....\$109,000	34' J/34, '85, <i>The Zoo</i> * .....\$29,900
52' Santa Cruz, '00, <i>Isis</i> .....\$520,000	40' Olson, 1983, <i>Elka</i> .....\$74,900	34' D-Class Catamaran, <i>Rocket 88</i> .....\$38,000
52' Santa Cruz, '99, <i>Renegade</i> .....\$595,000	40' Advance, '85, <i>Caribou</i> * .....Reduced \$119,000	34' MJM 34z, '05* .....\$365,000
52' Santa Cruz, '98, <i>Hula</i> .....Reduced \$495,000	38' True North 38, <i>Zest</i> .....\$375,000	34' Olson-Ericson, '89* .....SOLD
52' TransPac with IRC mods, '03, <i>Braveheart</i> * .....\$499,000	36' J/109, '03* .....\$189,000	33' J/100, Hull #9, '05 .....\$106,000
48' J/145, Hull #9, '03* .....\$675,000	35' J/105, Hull #502, '02, <i>Grace O'Malley</i> .....\$115,000	33' Frers Carroll Marine .....SOLD
48' 1D48, '96, <i>Cal Maritime</i> .....\$140,000	35' J/105, '02* .....\$99,000	32' J/32, '02, <i>Tango</i> .....\$119,000
47' Valiant, '81, <i>Sunchase</i> .....\$140,000	35' J/105, '01, Hull #469, <i>Streaker</i> .....\$115,000	32' J/32, '97, iAn Alaska .....\$109,000
44' Kernan, <i>Wasabi</i> .....Just listed \$429,000	35' J/105, '01, Hull #443, <i>Vuja De</i> .....Pending \$109,000	32' Catalina 320* .....Just listed \$61,000
44' J/44, '93, <i>Halcyon Days</i> * .....\$315,000	35' J/105, Hull #347, '00, <i>Bald Eagle</i> .....\$109,000	30' Knarr, '80 .....\$30,000
42' Custom Wylie, <i>Scorpio</i> .....\$169,000	35' J/105, '99, <i>Life Is Good</i> * .....\$83,000	29' MJM 29z, '07* .....\$269,000
42' Beneteau First .....\$89,000	35' J/105, Hull #103, '95, <i>Aquavit</i> .....\$89,000	28' Alerion Express, '06* .....\$99,000
41' J/124, '07, <i>Fortuna</i> .....\$279,000	35' J/35, '84, <i>The Boss</i> * .....\$39,900	26' J/80, '83, <i>Idaho</i> .....\$32,900
40' J/122, '07, <i>TKO</i> .....\$469,000	35' 1D35, '00, <i>Great Sensation</i> .....\$84,900	
40' J/40, '86, <i>China Cloud</i> .....Reduced \$149,000	35' 1D35, '01, <i>Yeofy</i> .....\$69,900	

\* Denotes Seattle Boats

# SAIL *California*

www.sailcal.com  
email: norman@sailcal.com, steve@sailcal.com

DEALERS FOR THESE FINE YACHTS:

**SABRE**

**Santa Cruz**  
YACHTS





- NEW
- USED
- REFINANCE



# Boat Loans Made Easy®



Let our 29 years of experience go to work for you!

**Richard Tressler**  
866-377-3948 ext. 47008  
[www.essexcredit.com](http://www.essexcredit.com)

EQUAL CREDIT OPPORTUNITY LENDER

Loan Amounts from \$25,000  
Instant Loan Approvals\* • 90 Days to First Payment\*

\*Subject to Loan Program Guidelines and Credit Approval  
Reference Code = MAR931

## CALENDAR

**SEQUOIA YC** — Every Wednesday night through 10/13. Steve Holmstrom, (650) 400-8584 or [steve@toothvet.info](mailto:steve@toothvet.info).

**SHORELINE LAKE AQUATIC CENTER** — Catalina 14.2 racing every Thursday night during Daylight Saving Time. Laser Racing every Wednesday night, May-October. John Stedman, (650) 940-9948 or (650) 965-7474.

**SOUTH BEACH YC** — Friday Night Series: 7/16, 7/23, 7/30, 8/6, 8/20, 8/27. Kevin, [rearcommadore@southbeachyachtclub.org](mailto:rearcommadore@southbeachyachtclub.org) or (650) 333-7873.

**STOCKTON SC** — Every Wednesday night through 8/25. Phil Hendrix, (209) 598-4415 or [regatta10@stocktonsc.org](mailto:regatta10@stocktonsc.org).

**TAHOE YC** — Wednesday Night Beer Can Series through 9/1. Monday Night Laser Series through 8/30. Darren Kramer, (530) 581-4700 or [www.tahoeyc.com](http://www.tahoeyc.com).

**TIBURON YC** — Every Friday night through 8/27 & 9/10. Ian Matthew, (415) 883-6339 or [ian.matthew@comcast.net](mailto:ian.matthew@comcast.net).

**VALLEJO YC** — Every Wednesday night: 7/7-9/29. Gordon, (530) 622-8761 or [fleetcaptainsail@vyc.org](mailto:fleetcaptainsail@vyc.org).

Please send your calendar items by the 10th of the month to [calendar@latitude38.com](mailto:calendar@latitude38.com). If you're totally old-school, mail them to *Latitude 38* (Attn: Calendar), 15 Locust Avenue, Mill Valley, CA, 94941 or fax them to us at (415) 383-5816. But please, no phone-ins! Calendar listings are for marine-related events that either are free or don't cost much to attend. The Calendar is not meant to support commercial enterprises.

### July Weekend Tides

date/day	time/ht.	time/ht.	time/ht.	time/ht.
	HIGH	LOW	HIGH	LOW
7/03Sat	0427/3.9	1029/1.2	1733/5.2	
	LOW	HIGH	LOW	HIGH
7/04Sun	0009/1.9	0541/3.5	1112/1.7	1811/5.4
7/10Sat	0510/-1.1	1233/4.6	1641/2.9	2253/6.8
7/11Sun	0553/-1.4	1311/4.8	1733/2.7	2343/6.9
	HIGH	LOW	HIGH	LOW
7/17Sat	0434/4.6	1017/0.9	1716/6.2	2346/0.9
7/18Sun	0558/4.0	1110/1.6	1805/6.3	
	LOW	HIGH	LOW	HIGH
7/24Sat	0524/-0.6	1238/4.8	1706/2.9	2306/6.2
7/25Sun	0559/-0.5	1312/4.9	1748/2.8	2346/6.1
	HIGH	LOW	HIGH	LOW
7/31Sat	0308/4.4	0903/1.3	1555/5.4	2208/1.9
8/01Sun	0405/4.0	0938/1.8	1630/5.5	2308/1.6

### July Weekend Currents

date/day	slack	max	slack	max
	7/03Sat	0109	0340/1.6F	0631
	1249	1601/2.3F	1917	2207/2.8E
7/04Sun	0216	0444/1.5F	0745	1020/2.0E
	1333	1649/2.1F	1959	2301/3.0E
7/10Sat	0001	0329/5.3E	0731	1037/4.0F
	1400	1607/2.2E	1908	2204/2.9F
7/11Sun	0049	0416/5.7E	0813	1118/4.4F
	1442	1654/2.6E	1955	2251/3.2F
7/17Sat	0041	0325/2.8F	0630	0910/3.2E
	1237	1541/3.2F	1850	2149/3.9E
7/18Sun	0152	0440/2.6F	0747	1010/2.3E
	1332	1636/2.7F	1940	2249/3.9E
7/24Sat	0015	0345/4.6E	0740	1052/3.8F
	1359	1633/2.0E	1926	2218/2.7F
7/25Sun	0100	0422/4.7E	0818	1128/3.8F
	1434	1700/2.2E	2006	2256/2.8F
7/31Sat		0212/2.2F	0509	0804/3.0E
	1120	1429/2.6F	1737	2036/3.2E
8/01Sun	0019	0303/2.0F	0604	0850/2.5E
	1150	1510/2.3F	1812	2123/3.2F

# SAIL INTO SUMMER

WITH A SAILBOAT FROM MARINA VILLAGE

Open Boat Weekend  
July 10-11

## FABULOUS NEW BOATS FROM

### Sail California



Santa Cruz 37



J/105



J/111



Summit 35

### Farallone Yachts



Ranger Tugs



Catalina 350



Catalina 375



Catalina 445

### Passage Yachts



Beneteau 34



Beneteau Oceanis 40



Island Packet Estero



Island Packet 465

Farallone Yachts  
Catalina  
(510) 523-6730

Passage Yachts  
Beneteau ✦ Island Packet  
Wauquiez ✦ Alerion  
(510) 864-3000

Sail California  
J-Boats ✦ Sabre  
Santa Cruz Yachts  
(510) 523-6730

**BROKERS**  
McGrath Yachts  
(510) 521-5020  
Orange Coast Yachts  
(510) 523-2628  
Richard Boland  
Yacht Sales  
(510) 521-6213

MARINA VILLAGE YACHT HARBOR

Much More than Just a Marina

(510) 521-0905 • [www.marinavillageharbor.com](http://www.marinavillageharbor.com)



# BERTH SPECIALS

## ❖ Liveboards

Select slips  
Apply now\*

## ❖ 60' Berth

Hard to find  
Available now\*



\* Limited opportunity.

## Ideal waterfront living on a Pacific Island!

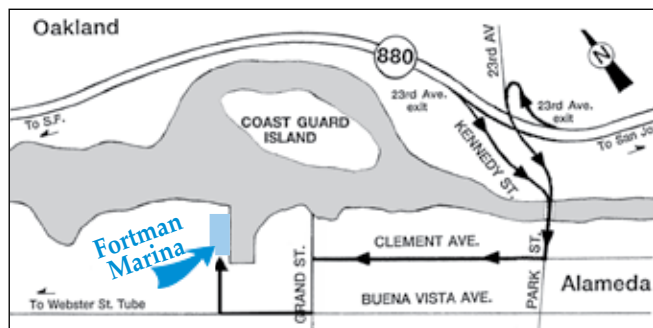

- Sheltered Alameda Location
- Competitive Rates
- Home of the Alameda Yacht Club

1535 Buena Vista Ave., Alameda, California  
(510) 522-9080

For directions and rates go to:  
[www.fortman.com](http://www.fortman.com)

# LETTERS

## ↑↓ I WOULD NOT PUT OTHERS AT RISK RESCUING ME

As a singlehander attempting to do a nonstop circumnavigation — starting from the Canary Islands last October — I found myself in a very similar situation to Abby Sunderland, but a few months earlier. Like Abby, I was forced to pull into Cape Town for repairs. But unlike Abby and Jessica Watson, I'm not into media rights and making lots of money from my attempt. I also don't have a big team with whom I'm in contact



COURTESY NEREIDA

**Jeanne Socrates. With age comes wisdom. At least in some people.**

with 24/7 by satphone for support and advice. I have none of that because I enjoy sailing and it's a personal challenge. I feel honored to have made lots of good friends because of my attempt, many of whom look out for me. And if I can raise some money and support for worthwhile charities along the way, so much the better.

I pulled into Cape Town in early December, hopefully for just a few days of repairs. At the time, I was aware that the season for continuing on in the Southern Ocean was closing because winter was approaching. I was headed to Cape Horn, and would have gotten there at end of February — which is late summer in those parts. Weather-wise, that should have been all right — but only just.

When my repair problems escalated, I found myself unable to leave until early March — three months later. As a result, I was forced to make the disappointing decision not to attempt Cape Horn, because it's not prudent to be sailing deep in the Southern Ocean in the winter. Even sailing past Australia to New Zealand in March was going to get more difficult because winter was approaching. Winter in the Southern Ocean means that deep, often violent lows, which are a regular feature of the region all year, move farther north. I had several days of stormy weather — up to 45 knots — when Jessica Watson was close by with *Ella's Pink Lady* near Tasmania, but I was managing to avoid the worst of the weather south of Australia in April.

So I was surprised when I heard that Abby was continuing on into the Southern Ocean in the winter. She would have been told by any South African sailor that it was not a good idea because of the strong weather down there at that time of year. In my opinion, her determination to go for the prize of being the youngest around clearly blinded her to the realities of the situation — and the likelihood she'd end up in difficulty of some kind.

I'm heading north now to re-start my solo round the world attempt, but in the right season. By starting from British Columbia in October, I should be in the Southern Ocean during the southern high summer months. I hope not to put other people at risk rescuing me simply because I was lacking in common sense and good seamanship — as I feel Abby and those involved with her attempt have been.

Jeanne Socrates

Nereida, Najad 380

From somewhere between New Zealand and Hawaii

*Readers — Jeanne cruised with her husband until he passed away. She became a last-minute entry in the '06 Singlehanded TransPac. She subsequently came within 85 miles of completing a singlehanded circumnavigation before a problem with*

**I WANT YOU**

*...to get the best marine repair and retrofit services in the Bay Area from the expert team at*

**SVENDSEN'S**

The highly skilled team at Svendsen's performs all services on site, including:  
**Wood & Fiberglass Repairs** ★ **Standing & Running Rigging** ★ **Repowers**  
**Bottom & Topside Painting** ★ **Computerized Engine Diagnosis & Engine Repair**  
**Electrical Repair** ★ **Custom Metal Fabrication** ★ **And Much More**  
Call to schedule: **510.522.2886** or schedule online: **svendsens.com**

For your convenience, Svendsen's on-site Chandlery is open 7 days a week!  
*Located adjacent to the Boat Yard. Chandlery: 510.521.8454 • svendsensmarine.com*

**SVENDSEN'S BOAT WORKS** | 1851 Clement Ave. in the Alameda Marina | svendsens.com

# Wrap Stars



## The Best in Furling Gear is All Right Here!

We can't think of anything that's done more to make sail handling easier, more convenient or safer than modern headsail furling systems.

Whether you are adding a new furling system to your boat, or need to replace some parts and pieces of the one you've already got, West Marine has what you need!

We carry furling gear from all the best brands, so we can help you to choose which system will best meet your sailing style and budget.

For more information about the furling systems we offer, visit [westmarine.com](http://westmarine.com) or our Rigging Shops in Alameda, San Diego or Seattle (Westlake).

**West Marine®**

We have 17 stores in Northern California, including our Alameda Sailing Superstore!

Visit [westmarine.com](http://westmarine.com) to find the store nearest you.

## LETTERS

her autopilot resulted in her first Nereida going up on a beach in Mexico while she slept.

### ↑↓ SAN FRANCISCO FLUBBED IT

My family and I recently returned to England, having visited San Francisco to watch the Clipper Round the World yachts complete the 5,680-mile Race 7 from Qingdao (China) to San Francisco. The competitors had to endure the most arduous and difficult weather the Pacific could throw at them, with very strong winds and tumultuous seas.

During the race, *California*, the State of California's representative, was dismayed and required assistance to get to San Francisco. Because she was escorted the last 2,000 miles by *Hull & Humber*, *Spirit of Australia*, and latterly *Edinburgh Inspiring Capital*, four boats arrived in San Francisco at about 9 p.m. on Sunday, April 4.

We and our family and friends had assembled at the Golden Gate YC to receive the crews after their 35 days at sea. So what a disappointment it was to find that the yacht club had not opened their bar, and no officials were present to welcome the crews and visitors. There was further disgust when the crews had to wait another 3½ hours for Immigration officials to allow them to enter the country. Further, the boats were moored on both sides of the harbor, so some of the crews had to walk the very, very long way around the harbor to get to the yacht club, which was their base. It appears that San Francisco virtually ignored the presence of these racing vessels and their crews.

When it came to a welcoming attitude and generous hospitality, San Francisco comes at the bottom of the list!

I note in your magazine that San Francisco is hoping to host the America's Cup. The city has had the opportunity to show what it can do, and flubbed it. In my opinion, San Francisco does not even deserve to be considered for hosting such a prestigious event.

I was pleased to read the article on page 92 of the May issue by Rob Grant. At least your magazine showed some recognition.

Brian Trelivijg  
Ex-Royal Navy

Brian — That you would rate San Francisco at the bottom of the list for hospitality shown to the Clipper Race boats doesn't particularly surprise us. Nor do we think it's unfair. Despite the



LATITUDE / ROB

fact the San Francisco was largely built on sailing, and was once the sailing gateway to trade with the Orient, the general population's primary interests lie elsewhere. That's just the way it is, as you can't make people like something.

Further, just because somebody puts the name 'California' on the transom of a vessel doesn't necessarily mean that Californians are going to identify with her.

If you look at the facts, the Clipper Race is undeniably a tremendous sailing adventure. Yet for whatever reason, it hasn't captivated the imagination or hearts of California sailors. Maybe it has something to do with its being a for-profit

# HELP THE HOMELESS IN HAITI BY DONATING YOUR USED SAILS.

Hood Sailmakers is pleased to announce that we are accepting donations of your old sails at our Sausalito loft as part of the [Sails for Haiti](#) and [Shake-a-Leg](#) programs. Join sailors from all over the country in helping one million Haitians who are still in need of shelter after the devastating January earthquake. Your donation could be tax-deductible and be used toward a **25% discount** on **new sails**. Please contact us today.

**HOOD** Roller Furler Cover Replacements

**HOOD** Furling Conversions

**HOOD** Pickup & Delivery

**HOOD** Sails & Service

**HOOD** Sail Repairs



**Made in the USA**

**Outbound Yachts  
New Outbound 52  
with Hood Vektron  
Vertical Full Batten  
In-Mast Furling  
Mainsail and 135%  
Vektron Genoa**

**PHOTO COURTESY  
SWIFTSURE YACHTS**

**HOOD SAILMAKERS 466 Coloma Street, Sausalito, CA 94965**

**Call Robin Sodaro (800) 883-7245 (415) 332-4104 Fax (415) 332-0943 [hoodsails@aol.com](mailto:hoodsails@aol.com)**

**Visit our website for Special Online Discount Pricing... [www.hoodsailmakers.com](http://www.hoodsailmakers.com)**

# Even Better!



**NEW!**

## Third Reef Foul Weather Gear

When we decided to update the world's best-selling foul weather gear, we didn't mess around. So our new Third Reef gear is our best ever! The newly re-designed coastal jacket is fully lined, breathable, 100% water- and windproof Oxford nylon fabric. Other features include an articulated Hi-Vis hood with brushed mesh collar, one-handed shock cord aperture adjusters, gusseted cargo pockets, zipped handwarmer pockets, internal zip pocket with headphone port, adjustable cuffs, internal Dartex storm cuff, adjustable waist with internal shock cord adjusters. Bibs use the same Oxford nylon fabric and are thoroughly reinforced at the seat and knees.

Jacket - \$129 Bibs - \$109

 **West Marine**<sup>®</sup>

We have 17 stores in Northern California, including our Alameda Sailing Superstore!

Visit [westmarine.com](http://westmarine.com) to find the store nearest you.

## LETTERS

*enterprise, that few of the participants have local ties, and that the event only stops here a few days every couple of years. We don't know.*

*As for the fiasco at the Golden Gate YC, we think the responsibility for that probably lies with Clipper Race organizers. If you're putting on an event, it's your responsibility to see that things are properly arranged with regard to facilities being open, shuttle boats being available to help crew get between their boats and the base, and in arranging for Customs and Immigration to be on hand in a reasonable amount of time. We hold our big Crew List Party at the Golden Gate YC each year, and thanks to coordination between our staff and the yacht club staff, the event has always gone very smoothly. (If it makes you feel any better, when the crew of our catamaran arrived in San Diego on a Monday morning recently, they had to wait nearly three hours for officials to clear them in. Something about an international flight arriving at Lindbergh Field.)*

*We think the America's Cup would be a very popular event if held on San Francisco Bay. On the other hand, honesty compels us to say that we don't think it would be as popular as it would be in England, Italy, France, Spain, New Zealand or Australia. That's just the way it is.*

### ↑↓ THE EASTERLINGS WERE SAFE SAILORS

They probably aren't any sailors in Northern California who haven't heard about the tragic deaths of Jeff and Beth Easterling during a sail from Half Moon Bay to San Francisco Bay on May 23 aboard their beloved Ranger 33 *Barcarolle*. I went to the memorial service, and was delighted to see over 200 devoted friends and sailors in attendance.

Jeff took me on my very first sailboat ride more than 20 years ago aboard *Barcarolle*, and I was hooked. In a matter of weeks, he helped me find my own sailboat, a Ranger 29. We logged more hours on our two Rangers than Columbus did during his lifetime.

I learned to sail by doing, but Jeff taught me how to survive when sailing. He was devoted to safe sailing and spent countless hours teaching me to read and understand charts, to read the weather, and to know how to handle any situation. Because of Jeff's patience and concern, he kept me, his novice sailing buddy, out of harm's way. In light of this, I'm deeply disturbed by the armchair sailors who claim that Jeff and Beth died as a result of Jeff's being reckless. Nobody knows what happened that fateful day, so I find any such speculation to be unseemly.

What I'll remember about Jeff is how he enthusiastically spoke about the day he could retire and spend his remaining life sailing *Barcarolle* on the blue waters of the world. He was a devoted husband and adored his children. He was a life's handyman, always willing and able to repair any problem, be it a broken prop shaft or a broken heart. Everyone who had ever met Jeff realized they had encountered someone of superior character, and were honored to call him a friend.

I say a last goodbye to my dear friend.

Steve Casper  
Wild Irish, Yamaha 26  
San Francisco

### ↑↓ WHAT'S THE DEAL WITH THE SOUTH CHANNEL?

The tragic loss of Jeff and Beth Easterling of the Ranger 33 *Barcarolle* got me thinking about the infamous South Channel entrance to the Bay from the ocean. Can *Latitude* review when the South Channel is safe, if ever?

I've used the South Channel twice, both on days when the swell was small. I was northbound on a Sabre 34 once;





# Berkeley Marine Center

*The yard that works for you!*

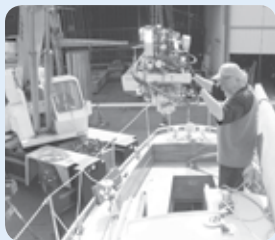

Maintenance,  
repairs &  
construction  
of yachts &  
commercial  
vessels

- Lift capacity 35 tons
- Sprayed Racing Bottoms
- Full Painting Service
- Fiberglass & Gelcoat Repairs
- Rigging Repairs & Installation
- Electrical Repairs & Installation
- Engine Service & Repowering
- Propeller Installation & Tuning
- Wood Hull Repairs & Caulking
- Teak & Non-Skid Deck Repairs

*Committed to the tradition of boating, and a tradition of customer service in everything we do.*



**Chandlery & Fuel Dock Open 7 Days**

Mon – Fri 8 to 5 • Sat & Sun 9 to 5

**In Berkeley Marina • 510-843-8195 • [www.berkeleymarine.com](http://www.berkeleymarine.com)**

# Pick Up Sticks

**Aluminum Battlesticks**  
\$41.99–\$84.99

**Carbon Battlesticks**  
\$57.99–\$122.99



## Ronstan Battlestick Tiller Extensions

You're thinking to yourself, "It's just a stick! How much can technology really add to that?" Quite a lot, as it turns out.

Ronstan has worked with top sailors, in big boats and small, to develop Battlestick Tiller Extensions that really *do* make a difference in the level of control and steering feel you'll have at the helm.

The key is the urethane universal joint, which provides smooth, uniform articulation and flexibility in any direction, while maintaining a sensitive feel for the tiller.

Battlesticks are available in Carbon or Aluminum in a wide range of lengths to suit everything from dinghies to offshore boats. See them online at [westmarine.com](http://westmarine.com) and in select store locations. Pick up a Battlestick and get a whole new grip.

 **West Marine®**

We have 17 stores in Northern California, including our Alameda Sailing Superstore!

Visit [westmarine.com](http://westmarine.com) to find the store nearest you.

## LETTERS

the other time I was southbound on a Californian 36 trawler. Each time I watched the depthsounder show quite shallow depths, making me wonder why I did it.

I understand that the accepted safe route is via the shipping channel and not turning to port for Half Moon Bay until you get to the Lightship. Any thoughts?

The other thing that seemed to come into play on that Sunday was the way the wind came up so quickly. I had just removed my coat on the Sabre 34 I was on just east of Alcatraz because it was so warm, and in seconds all hell broke loose in terms of wind and current. This happened right about the time we heard the distress call regarding *Barcarolle*. There was also a major flood starting, so I don't know if that came into play.

My deepest sympathy to the families of Jeff and Beth.

Bob Wills  
Santa Rosa

*Bob — We fully agree with Kimball Livingston who, writing in his Blue Planet Times, used the title 'The Alleged South Channel' for his article on the incident. Both Livingston and we have been around long enough to know that far too many lives*



KIMBALL LIVINGSTON

*and boats have been lost attempting to use the so-called South Channel off Ocean Beach and/or the South Bar that forms a shallow semi-circle to the south of the main shipping channel. Given the way the sand bottom can quickly change off Ocean Beach, we*

**'Barcarolle' wound up on China Beach.** *\_\_\_\_\_ frankly don't think there is any way to know at any given time whether a channel really even exists. This is certainly one place where you don't want to put blind faith in the charts.*

*With the proviso that we don't think anybody knows if the Easterlings tried to use the South Channel, or if their route had anything to do with their tragic demise, the safest thing is to never use it — and never cross the South Bar either. The problem is that it's so tempting to use the Channel or cross the Bar because they are much quicker ways of getting into the Bay than going all the way around the Lightbucket. It's also tempting because they are often transited without a problem. Nonetheless, since the first issue of Latitude in '77, we've periodically had to report on crews and boats that have gotten into big trouble — if not been lost — as a result of not taking the long way around.*

*Obviously, the most important factor in deciding to risk cutting the corner is the size of the swell. If it's moderate or is forecast to build, forget the alleged South Channel and be very wary of going over the South Bar. You might think that you're fine in 30 feet of water five miles off the beach, but history has proven time and again that that's not necessarily true. If the tide is ebbing, or if you're going to be in the Channel or crossing the bar when it's ebbing, it's much worse. In an ebb, it can take several hours from the time you enter the shallow water of the channel or the bar to the time you exit either of them into really deep water again. And if you get trapped in the South Channel or on the South Bar when things go bad, you're going to be fighting for your life in very difficult conditions to get back to the safety of deep water.*

# COME VISIT COYOTE POINT MARINA:

*The Peninsula's Complete Recreational Destination!*



**Multihull  
side ties available  
up to 40 ft.**

## **BERTHING**

- Slips to 40' available
- Inside ties from \$85 per mo.
- Multihull side ties available
- Check out our rates!



## **FUEL DOCK & PUMP OUT**

- Open 7 days per week
- Gas and diesel available
- Check our prices
- Free pump outs



## **COYOTE POINT RECREATIONAL AREA – HOME TO:**

- Coyote Point Marina
- Poplar Creek Golf Course
- Coyote Point Park
- Captain's House Conference Center
- Beach, Picnic & BBQ Areas
- Coyote Point Yacht Club
- Dominic's Restaurant
- Magic Mountain Playground
- Coyote Point Museum
- Shoreline Trail

**COME FOR A VISIT – WE THINK YOU'LL STAY**

*Call us and mention this ad for a FREE Weekend Guest Berth*

**COYOTE POINT MARINA ~ 1900 Coyote Point Drive • San Mateo**

**650.573.2594**

# Spin Doctor



## McLube Sailkote® Dry Lubricant

Every sailboat relies on gear that spins, or slides, or otherwise has to move to operate. And the easier those pieces of gear can move, the better they work. And the better *they* work, the less you and your crew have to work. So essentially what we have here is the classic "win-win situation". Which is why most sailboat racers, who care a lot about winning, use this stuff. Team McLube Sailkote® is remarkable in that it bonds to most any clean, dry surface and repels dirt, salt and grime that can gum up the works. It reduces friction and drag between surfaces in contact with air, water or other materials. The result is smoother operation of all the mechanical bits and pieces that you use for sail handling aboard. So give McLube Sailkote® a spin. You don't have to be a racer to be a winner!

Available in all West Marine stores in sizes from 6oz. to Gallons.



# West Marine®

We have 17 stores in Northern California, including our Alameda Sailing Superstore!

Visit [westmarine.com](http://westmarine.com) to find the store nearest you.

## LETTERS

### ↑↓ DECIDING WHO IS AN ASSHOLE, IF NOT BOTH

During this year's Master Mariner's Regatta, my crew and I were involved in a very frightening situation. As an experienced sailor who prides himself on an awareness of the rules of the road, I have always understood that the starboard tack boat has the right-of-way. More importantly, I have also understood that the captain of every vessel has responsibility for the safety of his/her passengers, crew and vessel, and that supersedes all other navigation rules.

On the second leg of the Master Mariner's Regatta, my old wooden sloop was heeled way over and was the last of three boats in a group heading from the Marin shore toward the north tower of the Golden Gate Bridge. Our genoa and full main blanketed nearly all our vision forward to starboard, and all our crew were on the high side. While sailing this course, I noticed a luxurious sloop motorsailing toward the second leg of the regatta for photo ops. This put them off my starboard side on the same tack. In a matter of five minutes, the large



LATITUDE / ANDY

boat disappeared from my view behind the sails.

After the second of the two boats in front of me tacked over, I told my crew we were going to do the same. Meanwhile, the luxurious boat motorsailing tacked behind my sails and out of my

**The annual Master Mariners race brings out lots of spectators — and potential collisions.**

sight. But once on a similar course, the skipper of the gold-plater chose to change course to starboard while motorsailing. It gave us a combined closing speed of about 12 knots.

Holding my course, I suddenly saw a wall of white fiberglass appear beneath my boom! By the time we crossed amidships, there was only about a foot between us. At that point I heard the cry, "Starboard tack!" We finished passing each other before the 'starboard' cry had ended. My eyes met the eyes of the other skipper at a range of about 10 feet. His eyes and mouth were wide open.

I raised my hand to apologize. After glowering, the other captain shouted, "Asshole!" Maybe he needed to do that to blow off some steam. As for me, I was breathless — but relieved that we had narrowly escaped a potentially lethal situation. Though my boat is smaller, there is no doubt that she, with her thick planks and heavy bronze nose, would have cut the bigger boat in two. Somebody could have been killed. My thoughts immediately switched from doing well in the regatta to getting home safely.

In my opinion, both the other skipper and I were at fault. But on our beautiful but dangerous Bay, isn't it everyone's responsibility to be safe, regardless of the right-of-way? What happened was my fault, and I have accepted responsibility for not seeing the other boat tack, and not knowing where they were. What happened was a natural result of my choices, as well as counting on others out there. But it was the other skipper's actions that put his boat and passengers in harm's way as well. I suggest that we both deserve the title 'asshole'.

Ted Hoppe  
Black Jack, 28-ft hard chine wood boat  
San Francisco Bay

Ted — We're confused. If you were sailing off the Marin shore

# AREN'T

# ALL BOATYARDS

# BASICALLY

# THE SAME?

The answer is yes, THAT IS... if you trust your boatyard to conduct quality repairs of your boat at the right price, with no nasty surprises when it comes time to pay the bill. Many sailors have discovered this kind of boatyard to be rare. At Bay Marine Boatworks, we pride ourselves on providing quality workmanship at a good value. We are a full-service boatyard whose mission is to guarantee absolute satisfaction to every customer. Our great customer service and communication helps to ensure that our customers are well informed about their choices for repair work and pricing.

Call us today to discuss your boat maintenance and repair needs!

- Collision Repair Work
- Fiberglass, Gelcoat & Painting
- Mast Stepping Rigging Work Mast Tuning
- Thru-hulls and Valves
- Drivelines and Engine Service
- Woodwork
- Welding & Metal Fabrication
- Electrical & Plumbing
- Sandblasting



310 W. Cutting Blvd.  
Pt. Richmond, Ca  
1-800-900-6646  
1-510-237-0140



[www.baymarineboatworks.com](http://www.baymarineboatworks.com)

**IT'S BEAUTIFUL...  
IT'S PRIVATE...  
IT'S HOME.**



**Making boating easier – and more fun! – is what Oyster Cove is all about.**

That's why we rate number one with many Bay Area boaters. Oyster Cove is an exclusive yet reasonable facility of 219 berths, accommodating pleasurecraft in slips up to 60-ft long.

**Oyster Cove is the private Peninsula marina closest to Blue Water boating.**

No other private Peninsula marina is better situated or offers nicer, fresher surroundings.

- Berths 30 feet to 60 feet
- Double Finger Concrete Slips
- Five Minutes from SFO
- Heated Dressing Rooms & Showers
- Laundry Room
- Nightly Security Patrol
- Complimentary Ice
- End Ties Available at \$5.95/Ft!



**OYSTER COVE MARINA**

**385 OYSTER POINT BOULEVARD #8A  
SOUTH SAN FRANCISCO**

**(650) 952-5540**

**[www.oystercovemarina.net](http://www.oystercovemarina.net)**

## LETTERS

toward the North Tower of the Golden Gate Bridge and Crissy, you must have been on starboard. But that would have meant you at the helm and all your crew on the high side would have had almost total vision forward to starboard. How can you say your starboard vision forward was blocked when all your sails would have been on the port side?

But whatever, because it doesn't matter what tack you're on, you're required to be able to see in all directions. If that means you need to put somebody on the bow, you have to do that. If that means you've got to get one of your crew to the low side, you've got to do that. There is absolutely no relying on other boats to see and avoid you.

Having said that, if you really were on port and just missed a collision with a motorsailing boat on starboard, it was his fault, not yours. As you surely know, all boats under power, even if they also have sail up, must give the right-of-way to boats under sail only. It doesn't matter who is on port and who is on starboard, and whether a boat is luxurious or about to sink.

We're also confused about this business about the captain's responsibility to keep his crew, passengers and boat safe superseding the rules of the road. Everyone's following the rules of the road is precisely what keeps everyone safe.

### ↑↓ GET THAT WRIST READY TO BE SLAPPED

Are you aware that results of the enquiry into the collision between Jessica Watson's *Ella's Pink Lady*, prior to the start of her solo circumnavigation, and the Chinese bulk carrier *Silver Yang*, has been released by the Australian government? It was summarized as follows:



AP PHOTO / ROB GRIFFITH

***Jessica Watson was in violation of the international rules during her solo circumnavigation. But then so is everybody who both singlehands and sleeps.***

The Australian Transport Safety Bureau (ATSB) investigation found that when the two vessels collided, neither the yacht's skipper nor the ship's watchkeepers were keeping a proper lookout, nor were they appropriately using navigational aids to manage the risk of collision. The investigation also found that following the collision, the ship's watchkeeper did not offer to assist the yacht's skipper. This is a problem that has also been highlighted by previous ATSB investigations. ATSB Chief Commissioner Martin Dolan said there are significant lessons to be learnt from this incident:

"This is a timely reminder that, under United Nations' conventions, ship operators have an obligation to offer assistance immediately to other vessels following a collision," Mr. Dolan said. As a result of the ATSB investigation, the following key safety actions were taken:

- *Ella's Pink Lady's* radar visibility was enhanced before departing from Sydney.
- The international requirement to render assistance following a collision has been highlighted.
- Attention has been drawn to the possible limits in the detectability of Class B AIS transmissions.
- *Silver Yang's* operators intend to undertake further training of deck officers.

We found the full report (available at [www.atsb.gov.au/publications/investigation\\_reports/2009/mair/268-mo-2009-008.aspx](http://www.atsb.gov.au/publications/investigation_reports/2009/mair/268-mo-2009-008.aspx)) to be intensely interesting, and recommend it to all

**GARHAUER**  
MARINE HARDWARE

*GREAT  
GEAR*



**Quality stanchions and gates from Garhauer**

**W**hether you are replacing one stanchion or upgrading your entire boat, we manufacture a complete line of stanchions, bases and gates.

- Stanchion tubes available in 3 different tip styles
- Stanchions and gates can be made removable or with fixed bases.



**GARHAUER**  
MARINE HARDWARE

1082 West Ninth Street,  
Upland, California 91786

Phone: (909) 985-9993  
FAX: (909) 946-3913

email: [garhauer@garhauermarine.com](mailto:garhauer@garhauermarine.com)  
<http://www.garhauermarine.com>

# WHALE POINT MARINE & HARDWARE CO.

**A FAMILY OWNED & OPERATED BUSINESS FOR THREE GENERATIONS**  
**MARINE PARTS & ACCESSORIES, PLUS A COMPLETE HARDWARE STORE**



Go to [WhalePointMarine.com](http://WhalePointMarine.com) for additional discounts!

## FORCE 10 Water Heater

120V with heat exchanger.



SS 6 gal • #406011 • **NOW \$269<sup>99</sup>**  
 SS 11 gal • #411011 • **NOW \$329<sup>99</sup>**  
 SS 20 gal • #418001 • **NOW \$399<sup>99</sup>**



## FORESPAR Mini-Galley

**NOW \$139<sup>95</sup>**

Mini-Galley comes with fimb cooking frame, perfect for any boat and uses standard propane cylinders.



## CANVAS BUCKET

Very handy bucket to have on your boat. Barely takes up any space... simply fold down to store.



List \$24.99  
**NOW \$19<sup>99</sup>**

## Z-SPAR PETIT Flagship Varnish

Highest UV protection available. Quart

Pint: List \$29<sup>16</sup>  
**NOW \$18<sup>99</sup>**  
 Quart: List \$49<sup>99</sup>  
**NOW \$32<sup>99</sup>**



## LELAND Strobe Light

**NOW \$19<sup>99</sup>**

Small and compact strobe light, fits in ones pocket, with 3-mile visibility, waterproof and last for 30 hours. D Cell Battery not included.



## TROJAN & CENTENNIAL Batteries

MARINE DEEP-CYCLE BATTERIES

24TM • 85amp ..... **NOW \$99<sup>99</sup>**  
 27TM • 105amp ..... **NOW \$109<sup>99</sup>**  
 6 Volt ..... **NOW \$139<sup>99</sup>**  
 8D • 12 Volt ..... **NOW \$169<sup>99</sup>**  
 Other amp sizes available.

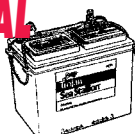

## HAPPY HOOKER Makes mooring simple!

**STEP 1:** Attach line to eye  
**STEP 2:** Push "Happy Hooker" forward to straddle mooring boy eye  
**STEP 3:** Pull "Happy Hooker" back  
**NOW \$39<sup>99</sup>**

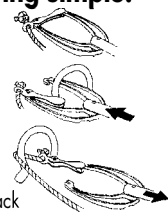

## HORSESHOE BUOY & M.O.B. POLE

USCG Approved

M.O.B. Pole **NOW \$149<sup>99</sup>**  
 Horseshoe or Pony Bouy **NOW \$89<sup>99</sup>**



205 Cutting Blvd, Corner of 2nd, Richmond  
 510-233-1988 • FAX 233-1989

Mon-Sat: 8:30am - 5pm • Sun: 10am - 4pm • [whalepoint@acehardware.com](mailto:whalepoint@acehardware.com)

Go to [WhalePointMarine.com](http://WhalePointMarine.com) for additional discounts!

## LETTERS

who are interested in the interactions at sea between yachts and commercial vessels. I'll leave it to others to decide what it means, but I thought the lack of professional skills and integrity on the part of the officers on the Chinese ship was shocking and frightening.

Many issues were raised and discussed at length. One that was never mentioned is that when *Silver Yang's* watchkeeper realized — some 2.5 minutes before contact was made — that a collision was likely, he failed to sound the ship's siren in the usual five blasts that indicates a dangerous situation is developing. That simple action might well have awakened Jessica in time for her to take evasive action.

At any rate, Jessica's behavior during and after the collision has increased our respect for her considerably, and is interesting to compare to Ms. Sunderland's various activities.

P.S. Thank you for your thoughtful posting on the Sunderland 'family of the year'. The additional information you supplied has ratcheted up our attitude from gentle disapproval to the goat-gagging level. But your reportage has been pretty damn good . . . for a Cal guy.

Jim & Ann Cate  
*Insatiable II*, Sayer 46  
 Iluke, NSW, Oz, heading north toward the sun

*Jim and Ann — What we take from the report is that it doesn't matter if you do anything wrong, because nobody will be held responsible in any meaningful way. That seems to be par for 'civilization' these days. Only Nature dispassionately holds people accountable for mistakes, which is why we find Nature more alluring with each passing day.*

*The other thing that wasn't mentioned in the report — at least from what we read — is that singlehanded for any longer than a day or so is in violation of international rules because no one person can stand watch 24 hours a day. Don't get us wrong, we're big supporters of long-distance singlehanded, but it's kind of funny, because the Aussies must have thought it would be embarrassing to point out that their latest sailing hero had been in violation of international law for the duration of her circumnavigation.*

*For readers who may not recall, the Cates are originally from Northern California, but in '86 set sail for the South Pacific and Australia aboard their PJ Standfast 36 *Insatiable*. Reporting they'd gotten caught in the 'South Pacific Eddy' for a total 85,000 miles with that boat, in '07 they moved up to custom built *Sayer 46*. If they plan on returning to the States anytime soon, they haven't mentioned it.*

### WHY SO STINGY WITH THE RAFT-UPS?

To all Northern California sailors who think the Park



*High winds and heavy traffic don't make Ayala Cove's moorings ideal for big raft-ups.*

Service has taken the fun out of Ayala Cove for us mariners, I agree! Going to Angel Island is and has always been about raft-ups of 3 to 10 boats for a fun weekend in the sun. But our lovely new moorings have ruined that — or have they? Maybe the Park Service doesn't understand moorings. It wouldn't be surprising, as

the Park Service isn't really water-based, is it?

The Park Service tells us that the new moorings are screwed into the famous mud bottom and can't handle more than





**Doyle Results**

- 1st 2009 Bedford Pitcher
- 1st 2009 Kiels Week
- 1st 2009 Lippincott Memorial
- 2nd 2009 Tulip Time
- 1st 2009 Annapolis Spring
- 2nd 2009 Bacardi Cup
- 2nd 2009 Levin Memorial
- 1st 2008 Schoonmaker Cup
- 1st 2008 Fall Wind Up
- 1st 2008 Tulip Time
- 7th 2008 Star Worlds



Utilizing innovative 3D modeling and rigorous testing, the Doyle Design Team is actively developing fast, smooth and durable one design sails for all conditions – upwind and down.

To learn more, call or visit [www.doylesails.com](http://www.doylesails.com).



San Francisco  
Bill Colombo & Dave Wilhite  
(510) 523-9411  
[sanfrancisco@doylesails.com](mailto:sanfrancisco@doylesails.com)

BETTER ENGINEERED SAILS

## LETTERS

two boats at a time. Is that right? The load strength is approximately seven times that of the largest old-style concrete blocks. In fact, they are more solid than any other type of mooring — including the mushroom, which the old *Lightship* used to maintain her position in the open ocean out past the San Francisco Bar. In storms, no less.

Let's figure out a way to get the Park Service to put the fun back into Angel anchorages again. At \$30 a pop they owe us something, don't they?

Jeff Berman  
*Perseverance*, Catalina 36  
San Francisco

*Jeff — The waters around Angel Island aren't the calmest in the world, so we suspect the Park Service's reasoning in not wanting 10-boat raft-ups isn't based on the danger that the moorings might fail, but rather that it's conceivable that two or even three 10-boat raft-ups might break loose and start mixing in unnatural ways. We could see three boats rafted together — as is permitted at most of the moorings at Catalina. If you want to raft with more than two other boats, we'd recommend rafting up at anchor in the lee of Angel Island or the Tiburon Peninsula, with everyone being responsible for whatever might happen.*

*For the record, our opinion is biased by the fact that we're not crazy about raft-ups in the first place. In most San Francisco Bay conditions, it seems as if it would be too easy for people to be injured or boats to be damaged. In places where the water is almost always calm — such as Newport Beach or La Playa Cove in San Diego — it's an entirely different story.*

### ↑↓ SIR ROBIN MAKES HIS OWN LUCK

In a recent *'Lectronic*, you mentioned the common



ONE-EYED JACK

***Knox-Johnston didn't believe he was rolling these when he took off around the world. Nor did he expect anybody to rescue him if he got into trouble.***

sailor's superstition about not starting a voyage on a Friday. When Robin Knox-Johnston was about to depart Falmouth, England, on June 14, 1968 — a Friday — in an attempt to become the first sailor to do a non-stop singlehanded circumnavigation, he was asked about the superstition. His reply was something

to the effect of, "I'm ready. My boat is ready. Why wait? I plan on making my own luck."

Charles Lane  
*Shamwari*, Tayana 37  
San Francisco

*Charles — And Sir Robin, as he's now known, did complete that voyage. He did another solo, nonstop circumnavigation at age 67, but didn't start that one on a Friday.*

*The thing that really got us interested in the 'Don't start on Friday' business was reading Irving Johnson's *The Peking Battles Cape Horn*. In the pages of that very engaging and educational little book, readers learn how very seriously some of the toughest sailors ever — it was taken for granted back then that some of the crew would die on every voyage — took that superstition.*



## ULTRAFEED® LS-1 & LSZ-1

The Ultrafeed® is a portable, cast iron power-house sewing machine with mechanical walking foot and Posi-Pin clutching system. Try the LS-1 for straight stitch sewing or the LSZ-1 for zigzag and straight stitch sewing. Experience the superior performance and versatility of an Ultrafeed® today.



[www.sailrite.com](http://www.sailrite.com)

FREE CATALOG • 800.348.2769 • 260.693.2242



## LET'S BE CLEAR ABOUT IT...

**"Dumping sewage anywhere in  
our waterways pollutes the  
environment."**

Disease, contamination, low oxygen levels and unsightly water are just a few of the devastating effects of boat sewage illegally dumped anywhere in our waterways and shoreline.

It's simple: You have to plan to properly dispose of human sewage from your boat. Boats with holding tanks must pull in and pump out at shore side pump out stations.

If you have a boat without holding tanks, plan your trip to use shore side restroom facilities.

Don't waste away our waterways! Proper disposal of sewage allows the living things in our waterways to keep on living.

**IF IT'S YOUR BOAT,  
IT'S YOUR RESPONSIBILITY.**

California Department of Boating and  
Waterways



For more information visit our website  
[www.BoatResponsibly.com](http://www.BoatResponsibly.com)

# Synchro Blocks



Lewmar synchro blocks are engineered for speed, efficiency and superior handling. We use a combination of scientifically optimised block geometry, a Free-Spin bearing and self-aligning head to reduce friction and increase efficiency by up to 40% over budget blocks on mainsheet systems. Which means each component is perfectly synchronised with the movement of the rope, providing you with an easier, smoother transfer of power from deck to sail and less wear on your rope.

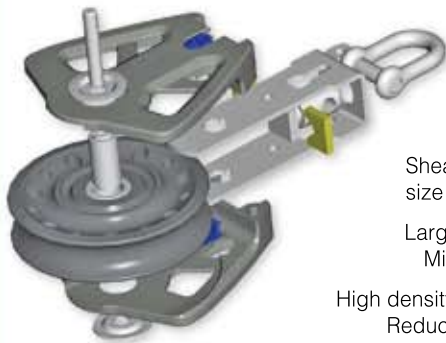

Easy to use shackle post lock - 360° rotation or locked

Lock mechanism - Enables 30° float

Sheave marked with line size & safe working load

Large sheave diameter - Minimizes rope friction

High density free-spin bearing - Reduces axle diameter for superior efficiency

## Features

- Stainless steel strap for best strength and longer service life
- Stiff glass fibre reinforced cheeks to prevent lines from wedging
- Innovative design with "tool-free" sliding swivel locking mechanism

Find Lewmar products at:

Svendsen's Marine  
Alameda, CA  
510-522-2886

KKMI  
Richmond, CA  
510-237-4141

Sea Tek Yachting  
Wilmington, CA  
310-549-1800

Rigworks  
San Diego, CA  
619-223-3788

Sausalito  
Marine Electric  
Sausalito, CA  
415-332-9030

**LEWMAR**  
www.lewmar.com

# LETTERS

## ↑↓ YOU TELL ME IT'S JUST SUPERSTITION

Jetti Matzke and I were lifted off my 32-ft catamaran *Eclipse* on the Gulf of Tehuantepec in January of '06 because of hurricane force winds and seas to 30 feet. We'd started our voyage on Friday the 13th. While the cat was recovered many months later, she was no longer of any value.

Richard Woods  
Cornwall, England / North America

## ↑↓ NEVER TURN YOUR BACK ON THE SEA

I could have used the advice of the little guy on my hand in the accompanying photo when I crossed the bar into Tomales



COURTESY LAGNAPPE

**Yellow rumped warblers are not uncommon visitors to boats sailing offshore.**

Bay a number of years ago. I had crossed that bar numerous times since my first time in '65. As I was careful to always do it at the end of a flood, I never had any problem.

This time we were motorsailing in, being careful to do it at the end of a flood tide.

The wind was light and there was nothing remarkable about the seas — although NOAA had posted warnings for hazardous seas. Mistake #1 was not knowing the actual height of the seas. Nonetheless, we were completely battered down and tethered with our harnesses. Mistake #2 was that we were on autopilot. Mistake #3 was that we didn't look behind us.

I had previously aborted attempts to cross the bar because it was obvious that waves were breaking all the way across the bar. This time we couldn't see any breaking in front of us. But the next thing we knew, we were being pooped by a breaking wave I estimate at between 5 and 7 feet. Water filled the cockpit, we were knocked down 60° from vertical, and we broached 70° off course to port. Surprise!

We struggled to get the autopilot turned off and the steering under control. We were somewhat successful, but didn't quite get the boat back on course before the second breaking wave



hit us. We broached to port again, although we weren't knocked down as far as by the first wave. Once we got the boat back on course and under control once again, we were hit by the third breaking wave. Fortunately, our stern lifted, and we surfed down the face of the wave on course.

**Based on simple geography, it's easy to see how waves can peak up at the bar entrance to Tomales Bay.**

"What happens if the keel hits bottom as we surf down the wave?" was the thought that ran through my mind. I

figured we might pitchpole. But a moment later we were in the tranquil waters of Tomales Bay and that was no longer a concern. We were a bit wet and shaken by the experience,



sikkens

We've spent years perfecting our long-lasting wood finishes. So then why do they have millions of tiny holes in them?

We know, just the mere mention of holes around a boat is enough to send a shiver down any old salt's spine. Still, holes happen to have a very useful place topside. Here's why: because wood is porous, it holds moisture. And typical wood finishes trap moisture resulting in surfaces that can crack and flake. Pretty unsightly stuff. To fix the problem, our Sikkens chemists designed a wood finish with millions of tiny holes, or pores, in it. So moisture can escape. Which means a much longer lasting finish. They also made sure the application process was fast and easy. After all, who needs to spend time painting when you can be out boating? But that's just part of the story. Cetol® was also designed to bring out the natural beauty and characteristics of your wood while protecting it from damaging UV rays – rays that can potentially cause color degradation. Just a few coats promise solid protection all season long. Hardly the same story a typical wood finish would tell. Cetol is also flexible. Which is kind of a big deal when you consider that wood constantly expands and contracts. Again, fewer chances of flaking or cracking. And there are four different colors to choose from including our new color Cetol Marine Natural Teak with Next Wave™ Technology. Imagine, a long-lasting wood-finishing product that's a cinch to apply. It's kind of a wood-finishing breakthrough.

Visit our website for more information:  
[yachtpaint.com](http://yachtpaint.com)

Sikkens®, Cetol® the AkzoNobel logo and all product names mentioned are trademarks of, or licensed to, AkzoNobel. © Akzo Nobel N.V. 2010.

*Enjoy the Simplicity*

MARINE WOOD CARE PRODUCTS





**South Beach Harbor is a great way to experience San Francisco. Boats of all sizes are welcome in our protected deepwater harbor. Bring your boat to South Beach and enjoy all the attractions of the city.**



- Two guest docks for boats up to 125'**
- 20 guest berths up to 50'**
- Casual and fine dining nearby**
- Adjacent to AT&T Park**
- Easy access to transportation**
- 24 hour security**
- Free pump-out stations**



**For Reservations:**  
 415.495.4911 (x0)  
 fax: 415.512.1351  
 sb.harbor@sfgov.org  
 www.southbeachharbor.com

## LETTERS

but otherwise all right. There was no damage to our Bruce King-designed Ericson 38. Dinner at Tony's that night helped us recover.

I'm not proud of the way that experience reflects on my seamanship, but I share it with others so they won't repeat my mistakes. Had we been under manual steering, with a bit of warning we were about to be pooped, we probably could have surfed dead down all three waves for a thrilling ride into Tomales Bay.

As for the bird on my hand in the photo, she's a yellow-rumped warbler. Twice on trips out to the Cordell Bank we've been joined by these birds 25 miles offshore. As many as nine or ten of them have landed on the boat at the same time. They are a riot, as they explore everywhere, including the inside of the cabin. They like to eat any kelp flies on the boat, which is nice. They showed no fear of us at all. In that sense they are a bit like the animals on the Galapagos Islands.

O'Neil Dillon  
 Lagniappe, Ericson 38  
 Emeryville

*O'Neil — You know what the Hawaiians teach their kids from a very young age? Never turn your back on the ocean. To which we'd add, never ignore forecasts of big seas, either.*

### ↑↓ FROM A CATAMARAN SURFING EXPERT

I am always interested and entertained by *Latitude's* articles about having fun on the water. And I follow the Baja stuff because I live in La Paz now. I always have to pick up a *Latitude* after a really bad day of doing boat repairs, because it reminds me that boating is fun. (I forget that when doing things like hanging upside down in the engine room.)

Regarding the discussions on cats crossing the bar, when I lived in Hawaii for a while, I worked for the Reef Hotel on Waikiki Beach. My job was crew aboard the 40-ft Rudy Choy *Keпоikai*. That's one of the tourist cats that would pick up as many as 20 passengers from right on the beach, sail out past Diamond Head, then back to the beach — usually with a great ride through the surf.

*Keпоikai* didn't have an engine; instead it was rigged with a small but colorful headsail. Thanks to her very shallow draft,



COURTESY KEPOIKAI

very light displacement, kick-up rudders and crew of only three, the ride through the surf back in to the beach was always the highlight of the trip. I recall that we really gave the mainsheet an extra amount of

### ***No motor, no problem for 'Keпоikai', eh brah?***

slack to be sure the main wouldn't catch a gust and drive us into a pitchpole. Besides, the jib did most of the work.

We always based our take-off on not just the wave's set, but also if there were canoes and surfers in front of us. We typically waited out a good set to allow everyone else to get out of our way. Interestingly, once we caught the wave, we became a vessel with limited ability to maneuver, and other folks were supposed to get out of our way.

The surf varied from day to day, and when it was really awesome, we would work an area where the break was less violent due to more gentle bottom contours. If the surf was too

*Come Visit Us Today!*

# SOUTH BEACH SAILING CENTER

at the  
beautifully renovated Pier 40 in San Francisco

## July To-Do List

*It's easy as 1-2-3*

- 1. Call Liz about new cushions*
- 2. Choose your style*
- 3. Go sailing!*



**415.543.1887**

**nbmc@earthlink.net**  
**www.northbeachmarinecanvas.com**  
**Pier 40, The Embarcadero**  
**South Beach Harbor, San Francisco**



## South Beach Riggers

### Winning Technology for the Hot Race or the Casual Cruise

- Expert advice, sales and splicing of Vectran, Spectra, Technora, and Dacron by our certified splicer
- Professional survey and tune for your rig
- Standing and running rigging replacement
- Fabrication and hydraulics
- More than 100,000 miles racing and cruising experience



### TWO LOCATIONS

**399 Harbor Dr. • Clipper Marina • Sausalito • 415.331.3400**  
**Pier 40 • South Beach Harbor • San Francisco • 415.974.6063**

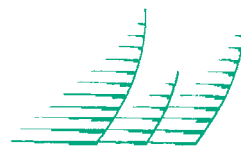

## Westwind

**Complete Yacht Care**

*Serving the entire Bay Area  
for more than 20 years*



*"Mike, we enjoy the boat so much more now. You do great work! Never thought it could look so good."  
- Tom Reilly,  
40' Sea Ray*



**(415) 661-2205**

Pier 40, South Beach on the Embarcadero • San Francisco

Call Toll Free **888-828-6789**



westwinddetailing@sonic.net  
**www.boatdetailing.com**



**Adjacent to South Beach Harbor and AT&T Park • Close to dozens of fantastic restaurants and shops**

# BLUE WATER YACHT INSURANCE

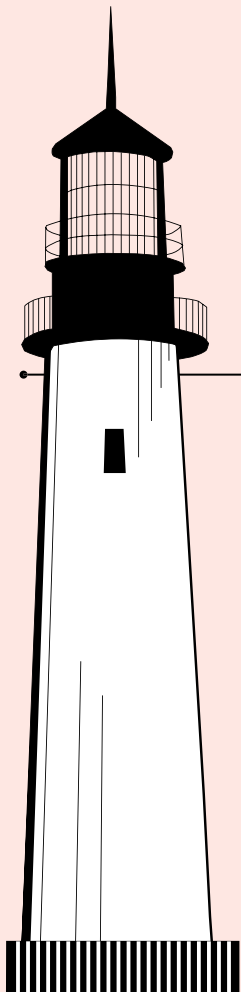

Blue Water Yacht Insurance covers more active cruising boats than any other marine agency in the Western Hemisphere, and is the leading innovator of insurance products for the offshore sailor.

## Our Insurance Programs Provide:

- Crew of two anywhere
- Worldwide Navigation
- Hawaii
- Caribbean
- South Pacific
- Mexico
- Charter Boats
- Multihulls
- Liveaboards
- Racing Boats

## Quality Rated Insurance Companies

Boats aged 1 to 40 years • "Agreed Value"  
"All Risks" • "New for Old" replacement partial losses  
Hulls valued \$50,000 to \$2,500,000

## Worldwide Health Insurance

International and USA health insurance plans  
at affordable prices.



BLUE WATER  
INSURANCE  
JUPITER, FLORIDA • USA

Call Toll Free  
**(866) 463-0167**  
Fax: (866) 795-3707  
sales@bluewaterinsurance.com

Quote requests  
Visit our website

[www.bluewaterinsurance.com](http://www.bluewaterinsurance.com)

## LETTERS

big to sail off the beach and through the break, we'd cancel the trips until it calmed down.

When we took off on a swell coming back in, the wave would often break just aft of midships, but in no time the cat would accelerate out in front of the wave. Once we were surfing, we really couldn't bear off until the break collapsed into foam near the beach.

Going out, of course, was way more challenging than coming back in. The process of lifting over a breaking wave would leave the first half of the hulls out of the water, and we'd be driving the cat pretty hard to penetrate the surf line. The landing was sort of a controlled crash. The sails had to be slacked so we would not lose steering ability while airborne.

Since then, I have played mostly on the water. For a time, I ran charter cats for The Moorings. Never did have an opportunity to drive one of them through a surf line though.

Capt. (ret.) Fred Snow  
Marquesa, La Paz, BCS, Mex

*Capt. Fred — Back when we used to cover all the big sailing events in Hawaii, we and our kids spent a lot of time on the sand and in the water at Waikiki, from which vantage points the charter cats were naturally the center of attention. While most of the cats seemed old and a little funky, we were always impressed at how skillfully they were handled. Of course, after going in and out several times every day, they had the place wired the way Gerry Lopez used to have the Pipeline wired. Very impressive.*

### ↑↓ "KEEP YOUR EYES ON A SWIVEL OUT ON THE BAY"

I want to thank Bar Pilots Unit 14 Capt. Chris Anderson for calling the Coast Guard after a near miss between an incoming container ship and me on my sailboard at 5 p.m. on June 16. I had not been paying attention, and I had no business being where I was. The wind suddenly died, and I looked up to see a huge ship bearing down on me. At one point I thought I was going to be run over. I felt like a mosquito about ready to be slapped. As it turned out, the ship's wake tossed me aside as the ship slipped by about 40 to 50 feet away. Note to fellow windsurfers: Keep your eyes on a swivel when out on the Bay. It's no place to have a 'senior moment'.

I see there was a Coast Guard safety meeting for us sailboarders at the St. Francis YC last Sunday. Unfortunately, I didn't know about it, nor did any of my Crissy buddies mention it.

Edwin Oviatt  
Sausalito

*Edwin — Thanks for sharing your experience. Hopefully it will prevent what may have been a future accident.*

### ↑↓ FRUGAL BOAT BUILDING TO THE NTH DEGREE

Max Ebb's articles on hi-tech rigs was thought provoking, but neglected to mention that each new advance is exponentially more expensive. The cost of fancy gadgets supposedly needed on a new sailboat is frightening, and soon only Wall Street traders will be able to go sailing.

By contrast, the stumpy masts and simple fittings of the ancient gaff rigs are cheap. For a smaller boat, one can go to the forest and cut some suitable saplings. Then, with a draw knife and plane, serviceable spars can be made for almost nothing. A visit to the local butcher will get a bone for the dog and some fatty offcuts to render into tallow. With this, one can slough down the mast so everything slides nicely. And even a somewhat nondescript sail, with four corners and hoisted



# Think Green, Buy Blue!

1.

Buy a new North sail between July 5th and September 3rd, 2010.

Recycle your old sail and **SAVE 25% on a new sail from North!**

As part of North's 10+ year commitment to recycling/repurposing sails, we are once again going to make it worth your while to *think green and buy blue!* Just register online and we'll send you a FREE UPS shipping tag along with your new sail so you can ship your old sail to the North Recycling Center. You'll automatically receive a 25% savings on the purchase price of your new North sail.\* Visit us at [northsails.com](http://northsails.com) to register and click on the "Think Green, Buy Blue" icon. You'll help the planet and save on North Sails, too!



\*North One-Design sails, Class Development Program sails and North Sails Direct sails are excluded. Offer limited to boats 50 ft. LOA and smaller. Customer must take delivery of new sail prior to November 30, 2010 and Recycled sail must be received by December 15th. Other restrictions may apply.



You'll receive a free North tote bag made from recycled sails with your new North sail.

Thanks for thinking green!

2.

Register online for your FREE UPS shipping tag and **25% SAVINGS** on your new North Sail.



3.

Return your old sail to the North recycling center **AND** get a **FREE** North tote bag made from recycled sails!



*Better by Design*

**Sausalito** 415-339-3000  
**San Rafael** - Sail Care 415-453-2142  
**Channel Islands** 805-984-8100  
**Marina Del Rey** 310-827-8888  
**Long Beach** 562-795-5488  
**Costa Mesa** - Sail Care 949-645-4660  
**San Diego** 619-224-2424  
[northsails.com](http://northsails.com)

# THE HEROIC TAILS OF ADVENTURE CAT!



HELLO THERE  
SAILOR...HAVE  
WE MET  
BEFORE?



IVE BEEN OUT PROWLING THE SAN  
FRANCISCO BAY FOR THE PAST 19  
YEARS USING MY WIND-POWERED  
CATAMARAN. IVE EVEN SAVED MORE  
THAN 500,000 GALLONS OF FUEL  
COMPARED TO THOSE OTHER  
EXCURSION BOATS ON THE WATER.



YOU SHOULD MEET ME AT PIER  
39 AND JOIN ME FOR A SAIL.  
ILL TAKE YOU UNDER THE  
GOLDEN GATE BRIDGE, CIRCLE  
AROUND ALCATRAZ ISLAND,  
PAST SAUSALITO AND OUT TO  
KIRBY COVE.

WHEN DO YOU WANT  
TO GO? IT'S UP TO  
YOU... IM OUT HERE  
THREE TIMES A DAY,  
SEVEN DAYS A WEEK!



TO LEARN MORE ABOUT  
ADVENTURE CAT, VISIT  
[WWW.ADVENTURECAT.COM](http://WWW.ADVENTURECAT.COM)

## LETTERS

by two halyards, can be set.

Would the result be efficient? Of course not! But it's better to sail less close to the wind than to not sail at all. By the way, what I describe is not from the passages of *Robinson Crusoe*, but rather what I did when building a 28-ft Sharpie in Redwood City in '60.

As a teenager in wartime England, I built a skiff, partly from lumber salvaged from bombed out buildings, and water-proofed with tar from the gasworks. I vividly remember sailing on the Thames in the summer of '44, watching the V-1 lights twinkling across the night sky, very much hoping the engines wouldn't cut out until they were well past. I was sailing on a gaffer then, too.

Leaving the U.K. in the mid-'50s, I settled in the Bay Area, and increasing affluence enabled me to acquire proper yachts with pointy headed rigs. But I am not positive they were more fun than boats built with as much ingenuity as money.

Building and sailing skiffs and dories is supposed to be quintessentially American. We read that there are hundreds of bored local youths, many drifting into drugs and crime. Would it not pay society to provide the planks, nails and hand tools for free so they could build boats? At least some of the lads might learn skills, character and initiative by building boats, without too much supervision. Providing, of course, the Bay Conservation and Development Commission (BCDC) did not classify the results as 'Bay fill'!

Michael Barton  
Dolly Grey, Aries 32  
Sunnyvale

*Michael — Times change and so do the interests of youth. We don't think many kids are going to want to ask a butcher — assuming they could find one — for some tallow. Or want to plane a sapling — assuming they wouldn't get arrested for taking one from a forest. Furthermore, we think the history of the state's giving anything to anybody in an attempt to motivate them has been dismal, usually resulting in people becoming more, rather than less, dependent.*

*What we try to do is publicize the great things that some sailors have done or are doing, and hold them up for youth to perhaps want to emulate. That's why we always like to feature articles that show how inexpensive it can be for people, particularly young people, to cruise.*

*But when it comes to frugal cruising, we'd direct youth away from wood gaffers and toward fiberglass Bermuda-rigged sloops of the '60s, '70s and '80s. For the most part, these boats were overbuilt, sail quite efficiently, and sometimes can be had for a song. Armed with one of these, a young man or woman with a couple of grand, snorkeling equipment and surfboards can have the adventure of a lifetime in Mexico or the South Pacific — or both. And when they return home a few years later, they'll likely be more intelligent, skilled and independent.*

### ↑↓AVOID BIRD FLU BY AVOIDING BIRD POO

While bringing the Hunter 410 *New Moon* back to California after the '06 Ha-Ha, we found out that it would have been easier to clear out of Mexico from somewhere other than Ensenada. When we got to Ensenada, a little man at Customs demanded we produce the original crew. After three hours of busting our chops trying to explain to him that they had cleared off the boat in Cabo and had long before flown home from there, the man's female supervisor intervened and verbally slapped him around. She told him that our documents were fully in order and demanded he clear us out. That really ticked him off.

# Key West 2011

January 17 - 21, 2011

Key West Race Week  
2011 "Must Do" Event

- + Amazing venue
- + Legendary event
- + World-class racing
- + Affordable & easier!

Key West Race Week 2011 — Racing sailors from across the country are making plans for their winter escape to Key West and Premiere Racing has taken steps to reduce expenses and simplify the logistics. Exciting details and real savings opportunities are posted on the event web site and will be updated throughout the coming months.

**Don't miss North America's number one regatta for One Design, IRC, PHRF and Multihull classes!**

SINCE 1703  
MOUNT GAY RUM  
BARBADOS

LEWMAR®  
NAVTEC

SPERRY  
TOP-SIDER

SLAM



The  
Florida Keys  
& Key West  
come as you are®

For invited classes, planning details and Notice of Race, visit:  
**[www.Premiere-Racing.com](http://www.Premiere-Racing.com)**

## Westpoint Harbor: A Unique Vision Is Realized in the South Bay



**REDWOOD CITY:** Unbelievably, it was all worth it. The decade of convincing the bureaucracies and agencies that this ambitious project could be done. The innovative methods used to dewater and stabilize the created shoreline. The transformation of what was a salt pond into 50 acres of a dynamic, thriving harbor with water clean enough to swim in. The construction and installation of novel concrete docks – one-piece fingers with rounded ends – never before seen in this area. The formation of a new, thriving maritime community. How best to explain the 22 years of fortitude? Patience? Perseverance? “Stubbornness,” clarifies Mark Sanders, who made it all happen. There’s never been a project like this attempted. The results are stunning – they need to be seen to be believed.



“We are among the many people who have followed this incredible project for much of the last 20 years, and we were among the very first tenants. Mark has really created a standard for this marina that sets it apart from all others and attracts a delightful and diverse cross-section of boats and owners. There is a real sense of community here; there’s always something going on – especially on the Party Barge! The facilities are simply unmatched and I appreciate the high-tech security measures. We were very selective in choosing this marina and are very happy here at Westpoint Harbor!”

– Rich and Connie Dancaaster

**A boost to South Bay sailing.** Westpoint Harbor faces the largest sailing area on the entire Bay. As the recent Westpoint Regatta participants attest, the area’s reliable breezes, protected waters and warm weather make for especially enjoyable sailing. Thanks to Redwood City being one of only four deepwater ports on the entire Bay, sailors enjoy a wide channel with depths up to 30’. Whether racing or cruising, Peninsula sailors – including those from the adjacent Sequoia Yacht Club – are already taking full advantage of the revitalization of South Bay sailing that Westpoint has helped to inspire.

**Best is yet to come.** This year will see the installation of more docks, ultimately resulting in a total of 408 slips averaging 50’ in length. In addition to the beautiful new harbormaster building, plans include a restaurant/coffee shop, full boatyard and fuel dock (that will be the Bay’s southernmost), dry storage, and a neighborhood of other marine-related businesses.

**Come see for yourself: The newest, most unique jewel of San Francisco Bay.**

# WESTPOINT HARBOR



## PRIVILEGES/AMENITIES

- Access to world-class Pacific Shores Health Club (pool, spa, gym, rock climbing wall, etc.)
- DSL phone lines *at every slip*, and free wifi access



## IDEAL LOCATION

- Redwood City enjoys 300+ sunny days a year
- Centered in the heart of Silicon Valley, between San Francisco and San Jose, near historic downtown Redwood City

## FABULOUS DOCKS

- Innovative single-piece concrete floats with inboard piles and under-deck guides
- Ultra-wide slips and fairways
- Dock box, dual 50 amp/120-240 volt power, and pumpout *at every slip*



## STUNNING NEW HARBORMASTER BUILDING

- 360° deck access with views of surrounding Westpoint Slough wildlife refuge
- Beautiful showers and rest rooms with granite countertops and ceramic tile
- Private meeting rooms

**650 224-3250**

**1529 Seaport Blvd., Redwood City, CA 94063**

**[www.westpointharbor.com](http://www.westpointharbor.com)**

# SHAFT SHARK

**The best rope,  
line and debris  
cutter there is!**

Two piece unit

For both power and sail

**Now available for  
sail drive systems.**



747 Aquidneck Ave.  
Middletown, RI 02842

**401-847-7960**

Fax: 401-849-0631

sales@ab-marine.com

**www.ab-marine.com**

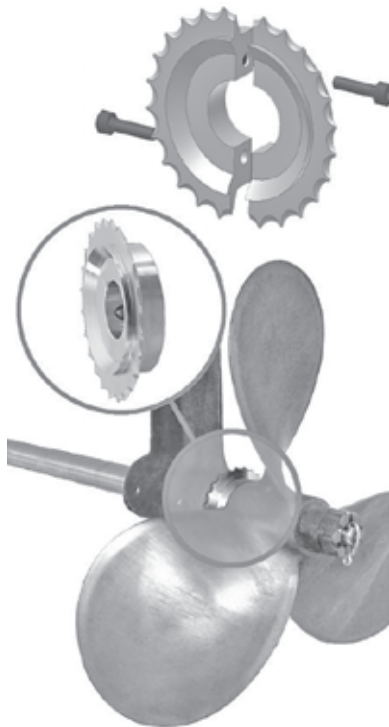

## LETTERS

On the way from Ensenada to San Diego, we picked up a boobie — blue-footed, I think — on top of the boom. Everyone wanted to give the tired bird a ride, as you reported Patrick Ralph did with the little black bird that landed on *Profligate* and caused so much trouble when they tried to clear into Customs. But after we smelled the boobie's stinky excrement the next morning, he was unceremoniously pushed overboard with a boathook, and the boom was washed down with buckets of water. Birds are messy hitchhikers.

Gary Scheier  
Serenisea 2, Hunter 37  
San Rafael

Gary — While the actions of the Customs man in Ensenada had to be infuriating, to a certain extent they are understandable. After all, when you clear into Mexico at whatever port, you'd think you'd get a new crew list to reflect who was going to be on the boat with you from then on. But no, you spend the rest of the season sailing around Mexico with a crew list reflecting people who got off the boat months before and not the ones who are on her at the time. A little strange, no?

Mexico is a fabulous country and a fabulous place to cruise, but their clearing procedures are still reliably inconsistent. For example, when you clear into La Cruz or Puerto Vallarta, you are required to visit the port captain. But when you clear into La Paz or other places, you can do it over the radio. Or, if you're in a marina in La Paz, the marina will do it for you. Consistently inconsistent.

Even more peculiar, if you're clearing out of La Paz for the United States, the port captain requires an expensive and inconvenient health clearance for the vessel and all the crew, and if we're not mistaken, a rat inspection, too. To our knowledge, this is the only port that requires it, which is why nobody clears out of La Paz for the States. If anybody has been required to get health certificates from any other ports in Mexico before heading for the States, we'd like to hear about it.

### ↑↓ WE FOLLOW THE PROFLIGATE TREATY

So what I read in the June 9 *Lectronic* is that, in spite of MARPOL rules, yachts entering the U.S. at San Diego are supposed to dispose of all of their garbage — including plastic bags — overboard prior to entry. This is illegal and doesn't make any sense.

Lon Bubeck  
Flying Cloud Yachts

Lon — Sorry, we weren't as clear as we could and should have been. As part of their "outreach," the very pleasant and professional folks from Customs told Doña de Mallorca, captain of *Profligate*, that: 1) You should separate all your garbage as follows: Anything "that is of plant or animal origin, including food scraps, packaging materials, and any items that have come into contact with these materials," needs to be kept in bags separate from all other garbage. That's because the former must be incinerated or sterilized, which costs taxpayers a lot of money. After being inspected, normal garbage can be thrown into normal garbage bins. What drives these folks nuts are the really big yachts that show up in San Diego with 40 bags of unseparated garbage. 2) It's recommended that certain foods, including, apples, raw chicken, raw beef, and avocados — to name just few — be thrown into the sea where it is legal to do so under MARPOL rules, rather than being brought into San Diego where it has to be confiscated. However, other fresh foods — such as limes, garlic, chilies, packaged deli meats and other stuff — can be kept.

## Gori propeller

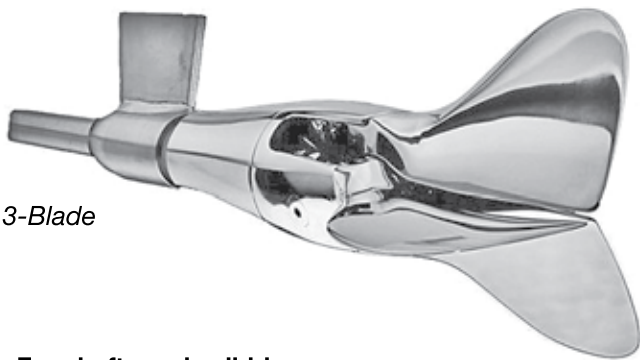

3-Blade

- For shafts and saildrives
- Both 2 & 3 blade available
- Lowest drag when sailing
- The champions choice



747 Aquidneck Ave.  
Middletown, RI 02842

**401-847-7960**

Fax: 401-849-0631

sales@ab-marine.com

**www.ab-marine.com**

**CALL US TODAY!**

**800-801-8922**

# HAPPENING HOMEPORT



**July 3: First  
Fireworks  
on the Bay**



**July 16-18:  
Catalina Rendezvous**



**July 30: Kickoff  
Party for the  
Delta Doo Dah**



**August 27 –  
September 4:  
Finn Gold Cup**

**We have many good reasons to call Marina Bay home!**

**Marina Bay Yacht Harbor**  
**[www.MarinaBayYachtHarbor.com](http://www.MarinaBayYachtHarbor.com)**  
**(510) 236-1013**



# Svendsen's Marine 4th of July BLOWOUT

Unprecedented Deal - Stock Limited

SolidNav Traveler  
Electric Sailboat Motor

**\$500 Off!**

This amazing deal is only available  
for a very limited time – buy now!

 SolidNav.com  
The best dealmaker for your boat



Anchor Clearance Sale –  
All Anchors in Stock

**20% Off!**

Fortress, Lewmar,  
SeaDog, & More



Big Savings on  
LunaSea Lights –

**20% Off!**

Includes all in-stock LunaSea  
light fixtures & bulbs, except  
LED replacement bulbs



Revere ComfortMax  
Manual Inflatable PFDs

**Only \$92!**

MSRP: \$137.50

USCG Approved. Superior comfort  
and safety. Rugged & easily  
adjustable. Navy Blue.



Limited to stock on hand. Sale ends 7/31/10.



**SVENDSEN'S MARINE**

Open 7 Days a Week - **510.521.8454**

Shop Online: [svendsenmarine.com](http://svendsenmarine.com)  
1851 Clement Ave., in the Alameda Marina

## LETTERS

Unfortunately, the USDA pamphlet contained no list of which foods had to be thrown away and which could be kept. And if you call the California number for the Department of Agriculture's Animal and Plant Health Inspection Service at (310) 725-1949 — as we dutifully did at 3:18 p.m. on a Thursday afternoon — you're likely to get a message, as we did, that tells you, sorry, nobody is there to help you at that time, but if you'll leave a number after the beep, they'll surely get back to you sooner or later. Unfortunately, immediately after the beep there was another message that said the machine couldn't take messages. Way to go, USDA Animal and Plant Health Inspection Service!

For the record, these are the rules under the MARPOL Treaty: If you're 25 miles offshore, the only thing you can't throw in



LATITUDE / RICHARD

the ocean is plastic. If you're 18 to 25 miles offshore, it's also illegal to dump dunnage and lining materials that float. If you're 3 to 12 miles offshore, you also can't dump paper, rags, glass, crockery, metal, food and plastic — unless it's been ground up to pieces smaller than one square inch.

The list of foods you can't bring back to the States is listed . . . er, nowhere on the special USDA pamphlet.

If you're less than three miles from shore, you can't throw any of the stuff overboard. And forget discharging oil anywhere at sea.

The Profligate Treaty states that you shouldn't throw anything overboard but food, and that only in accordance with MARPOL, which means 3 to 12 miles for stuff under one square inch, and 12 to 25 miles for larger pieces.

### ↑↓ MARIN SHERIFF'S MARINE UNIT TO THE RESCUE

While sailing a small dinghy across Raccoon Strait on June 5, to my great consternation and embarrassment, I capsized. After several failed attempts at righting my vessel, I grew tired and cold, and realized I was in real trouble. Far more trouble than I had bargained for. Rescue attempts by passing sailboats were ineffective and clearly dangerous.

Whether it was God's intervention or just plain luck I will never know, but the rapid response of the Marin Sheriff's Marine Patrol has to be recognized and praised. Sheriff Deputies Nicholas Pottoroff and Jon Harrison took immediate charge. It rapidly became clear to me that they were well-equipped, highly-trained, and extremely competent. Simply put, they saved my life. I was quickly transported back to Tiburon, where I was met by the Tiburon Fire Department and EMR units, which the deputies had arranged for en route. The deputies not only stayed with me during this evaluation, but also coordinated, with folks from the Corinthian YC, the retrieval and return of my vessel.

My thanks for a job well done!

R. Wm Schmidt, MD  
Tiburon

R. — A tip of the Latitude hat to the Marin Sheriff's Department. But what troubles us is that "passing sailboats" were unable to save you from what might have been a terrible fate.



California Certified  
Clean Marina

# BERKELEY MARINA



**Centrally located off Hwy. 80 at University Ave. • Fast Access to the Central Bay • Fuel Dock • Marine Center with 35 Ton Lift Capacity • Launch Ramp • Waterfront Hotel • Restaurants • Adventure Playground • 17 Acre Off-leash Dog Park • Picnic Sites • Deli and More...**

## Available Berths\*

84' Downwind Double, Live-aboard . . . . .	\$1,071.84/mo	50' Downwind Single, Live-aboard . . . . .	\$709.00/mo
65' Downwind Double, Live-aboard . . . . .	\$928.25/mo	48' Downwind Double, New Docks . . . . .	\$441.60/mo
65' Downwind Double . . . . .	\$783.25/mo	48' Downwind Double, New Docks . . . . .	\$441.60/mo
65' Crosswind Single, Live-aboard . . . . .	\$928.25/mo	41' Upwind Single . . . . .	\$472.32/mo
65' Crosswind Single . . . . .	\$783.25/mo	40' Downwind Double . . . . .	\$368.00/mo
60' Downwind Double . . . . .	\$621.00/mo	40' Downwind Double, Live-aboard . . . . .	\$513.00/mo
60' Upwind Single . . . . .	\$788.40/mo	36' Upwd 2-wide/Multihull, New Docks, Live-abd . .	\$832.47/mo
60' Downwind Double, New Docks . . . . .	\$585.00/mo	36' Upwind Double, New Docks. . . . .	\$343.73/mo
52' Upwind Double . . . . .	\$586.56/mo	36' Downwind 2-wide/Multihull, New Docks . . . . .	\$624.96/mo
52' Upwind Double . . . . .	\$586.56/mo	36' Downwind Double, New Docks . . . . .	\$312.48/mo
52' Upwind Double, Live-aboard . . . . .	\$731.56/mo	36' Upwind Double . . . . .	\$343.73/mo
50' Downwind Single . . . . .	\$564.00/mo	32' Downwind Double . . . . .	\$277.76/mo
50' Downwind Single . . . . .	\$564.00/mo	30' Upwind 2-wide/Multihull, New Docks . . . . .	\$572.88/mo

Berths subject to availability

\*all rental agreements & permits subject to approval of application and vessel inspection. Customer responsible for 1st month rent plus deposit, and all applicable fees.



**CITY OF BERKELEY**  
PARKS RECREATION AND WATERFRONT

**Berkeley Marina Office**  
**201 University Ave. • 510-981-6740**

Visit our website at: [www.ci.berkeley.ca.us/marina](http://www.ci.berkeley.ca.us/marina)



MARINA RIVIERA NAYARIT  
AT LA CRUZ

**MORE THAN 340 VESSEL  
CAPACITY (30-400 Ft)**

FUEL STATION - DRY DOCK - 150  
TON TRAVELIFT - YACHT CLUB

*El sueño hecho marina...*



*Come and enjoy our beautiful marina with first class  
services surrounded by spectacular views  
of the Banderas Bay.*



*"one of the best experiences, no hesitation in  
letting others know what a great place you have -  
thanks to all who made our stay so enjoyable"*

*Andrew Linney, www.nokaoi2.info*



**LAT 20°45'N / LON. 105°24'W**

Marina Riviera Nayarit, Marlin 39-A  
La Cruz de Huanacastle, Nayarit, MX 63734  
harbormaster@marinarivieranayarit.com  
Tel. (329) 295.5526 • Cel (322) 205.7467  
www.marinarivieranayarit.com

## LETTERS

### ↑↓ **A BETTER JACKLINE SET-UP**

I've noticed recent articles about sailors falling overboard at sea, and various schemes — such as the loop or bobstay methods — for them to get back aboard. A conclusion reached in these articles was the best solution is to *not* fall off the boat in the first place.

I agree with this thinking. The first line of defense against going overboard is using a harness and having a suitable line to clip the harness onto. Even with these precautions, it's possible to fall overboard while being attached to your boat, and be dragged in the water until you're dead! *Latitude* has reported on such things happening on more than one occasion.

When I look at boats with jacklines, many have them attached on either side of the boat near the cap rail. If someone were to fall overboard using the setup, even if they were wearing a short harness, they'd be smashed against the hull if not knocked out. And even if you were Superman, you'd still not be able to get yourself back aboard.

To prevent this from happening, I've always used a central jackline with short harness attachment so, if I did lose my balance and fall, I would be confined to the deck of the boat, and not go beyond into a head-cracking experience followed



TONY BADGER

***In 1968, Jody (left) fell overboard, but her parents were able to pull her back aboard thanks to her old-school tether. She's now approaching 50.***

by my dragging in the water until dead. My system runs from the stern to the bow, with lines on either side of the mast. They allow free movement along the length of my boat. I shudder when I see jacklines running along the toe railing or in close proximity to it, as it really is an accident waiting to happen.

In fact, I know this to be true from personal experience. On a crossing from St. Thomas to Panama, my daughter fell overboard. Attached to the boat by her lifeline, she was sucked up against the hull. We didn't even know she'd fallen overboard until we noticed the strange turbulence behind the boat! When we looked over the side, there she was! If we hadn't been on deck, the outcome could have been much different. At that time, we were using double jacklines that weren't near the center of the boat, which meant they still allowed my daughter to go overboard.

Tony Badger  
*Kingfish, Fisher 37*  
Sausalito

*Tony — Makes sense to us.*

### ↑↓ **REITERATING THE POINT**

When I sent you my recent email of May 15 [*Editor's note: see the letter directly above*], little did I know that four more sailors would be lost at sea off the coast of California. I knew one of them — Felix Knauth — personally. In all the cases, the still-floating boats made it to shore while the sailors didn't. It's my belief that if the boats had had central jacklines and the crews had been wearing short harnesses, their chances of

# Offshore Adventure Sailing

## What we do best



**LEG 1 - Newport Beach to Easter Island**  
 24 days 3800 mi. Oct 30 - Nov 23, 2010  
 Fantastic open ocean sailing, an equator crossing and landfall in the world's most remote inhabited island. \$3950

**LEG 2 - Easter Island - Puerto Montt, Chile**  
 19 days 2500 mi. Nov 24 - Dec 13, 2010  
 Primal Moai statues make a dramatic backdrop as *Eagle* sails into the southeast trades toward Chile. There will be plenty of time to practice celestial and other traditional sailing skills. \$3050

**LEG 3 - Puerto Montt, Ushuaia, Argentina**  
 23 days 1400 mi. Dec 19 - Jan 11, 2011  
 This area is less traveled than Antarctica with some of the world's most spectacular scenery. Conditions are varied with literally sun and snow on the same day. Days will be spent exploring the inlets where glaciers, waterfalls and snowcapped peaks are found. \$3850

**LEG 4 - Ushuaia - Cape Horn - Ushuaia, Argentina**  
 10 days 300 mi. Jan 18 - Jan 28, 2011  
 Covering three hundred miles in ten days sounds easy unless the itinerary is a rounding of notorious Cape Horn. While on many sailors list, this is not a trip to be taken lightly. \$3000

**LEG 5 - Ushuaia - South Georgia Island - Buenos Aires, Argentina**  
 31 days 2700 mi. Feb 4 - March 7, 2011  
 Extreme sailing and an exploration of a magnificent sub-Antarctic island, followed by a grueling stretch of Southern Ocean sailing to Buenos Aires. \$6900

**LEG 6 - Buenos Aires - Rio de Janeiro, Brazil**  
 14 days 1200 mi. Mar 14 - Mar 28, 2011  
 Stopping in Punta del Este and Rio de Janeiro, *Alaska Eagle* will be returning to two of the ports that were part of her Whitbread Racing career. \$1950

**LEG 7 - Rio de Janeiro - English Harbor, Antigua**  
 28 days 3500 mi. Apr 1 - Apr 29, 2011  
 Southeast trades, an equator crossing, then on to the Northeast trades! Arriving in Antigua will be the culmination of nearly a month at sea and *Alaska Eagle's* South American adventure. \$2895

The School of  
**SAILING & SEAMANSHIP**  
 \ Orange Coast College



**www.occsailing.com**  
**949-645-9412**  
 1801 W. Coast Hwy,  
 Newport Beach, CA 92663



This year's voyages are for those looking for extreme adventure. These voyages are the heart and soul of what *Alaska Eagle* was built to do: Sail extended offshore voyages to exotic destinations.

This year's applicants must have a strong sailing background, be in excellent physical condition and have a highly honed sense of adventure.

**ALASKA EAGLE**

## NAPA VALLEY MARINA: DISCOVER THE DIFFERENCE

- ✓ 35 Acres
- ✓ Haul-out with NO STRAPS
- ✓ Seven wineries within 5 miles
- ✓ 24-hour access
- ✓ Deep water
- ✓ Family owned for 53 years
- ✓ Laid back
- ✓ Scenic surroundings
- ✓ Approachable workforce
- ✓ Courteous, seasoned staff
- ✓ Reasonable rates
- ✓ A handshake means something
- ✓ Quality workmanship



*California's largest dry storage facility*

## NAPA VALLEY MARINA

1200 Milton Road • Napa, CA 94559

(707) 252-8011 • Fax (707) 252-0851

[www.napavalleymarina.com](http://www.napavalleymarina.com)

Marina • Boatyard • Chandlery • Brokerage

Dealers for  
**YANMAR**

**Interlux**  
yachtpaint.com

Distributors for *Brownell*  
Boat Stands

## LETTERS

staying with their vessels, and living, would have been much greater. I firmly believe that it's crucial that one's jackline and safety harness system not allow any crewmember to go overboard.

Tony Badger

### ↑↓ HOW DO SINGLEHANDERS DO IT?

As a budding solo sailor, I'm curious how experienced singlehanders plan to get back aboard their boats if they go over. That assumes that they're tethered, but on a long-enough leash that they could end up hanging over the side, perhaps even dragging in the water.

Carey Jones  
*Dolce Vela*, S2 9.2A  
Chelsea, Michigan

*Carey — When we've singlehanded, our assumption has always been — and continues to be — that if we go overboard, we'll die. End of story. Actually, that's always been our assumption even if we have crew, so we try really hard not to go overboard.*

*Not all singlehanders are as fatalistic. We hope some of them will be kind enough to share their get-back-aboard strategies.*

### ↑↓ THERE ARE BETTER PLACES THAN THE ALA WAI

I read with interest *Latitude's* May issue commentary on the Ala Wai Yacht Harbor in Honolulu. Having lived in Hawaii for close to 19 years, I was a slipholder there as well as a member of the Hawaii YC.

Unfortunately, the Ala Wai has always been a second- or third-class facility. It's not too surprising, given the Third World mentality of the state government in Hawaii. These folks have been milking the marina income for many years, while spending the excess on non-related things.

Hawaii is so anti-boating that it was a miracle that HASEKO, a Japanese Developer, was successful in building their beautiful marina facility out at Ko Olina. I attended several of the meetings prior to the marina's being built, and saw what big opposition they faced. But it's where I would keep my boat if I still lived in Hawaii.

With regard to living aboard at the Ala Wai, we lived aboard on the 400 Row for a while. It was hot and noisy, and there were parking and other problems. There are better places!

Garry Powell  
Portland, OR

*Garry — We hate being so cynical, but there seems to be endless evidence — from Arlington National Cemetery to the Ala Wai — that government on all levels is a bad brew of incompetence, inefficiency and corruption. Can't we do better? Can't anyone in government service be held accountable?*

### ↑↓ WE'RE ASHAMED FOR A DIFFERENT REASON

I'm sorry, but I think spearing a trophy fish using scuba gear is pathetic. Fish like the pargo featured in the May 24 *'Lectronic* are the breeding stock for an entire species, not just trophies for sailors who believe they are on some sort of a self-realization trip. I say have fun — but play fair. And it's not really the size that counts. By the way, it's not just the Mexicans who have diminished fish stocks in the Sea of Cortez, as cruisers from the north have played a part as well.

Tom Woodruff  
*Mischief*, Mermaid  
Sea of Cortez, '79

Management  
Consulting  
Development



## Almar Marinas

Join one Almar Marina and you have reciprocal privileges at any of Almar's 17 locations from San Francisco to San Diego and out to Hawaii. Programs included in your slips fees:\*Boat Handling Classes\*Navigation Courses\*Electrical Courses\*Anchor Outs\*Seminars on Local Destinations.



EST. 1973

[almar.com](http://almar.com)

San Diego\* Cabrillo Isle Marina\* Marina del Rey\* Marina del Rey Marina\* Channel Islands Harbor\* Bahia Marina\* Anacapa Isle Marina\* Peninsula Marina\* Westport Marina\* Ventura Harbor\* Ventura Isle Marina\* San Francisco Bay\* Treasure Isle Marina\* Jack London Square\* Jack London Square Marina\* Oakland\* NEast Basin Marina\* NWest Basin Marina\* Embarcadero Marina\* Union Point Marina\* Alameda\* Ballena Isle Marina\* Martinez\* Martinez Marina\* CA Delta\* RiverPoint Landing\* Honolulu\* Kewalo Basin Harbor\* Oahu\* Iroquois Marina\*

# 2010 MODEL CLEARANCE



**2011 Models Began Arriving in June.**  
**Best deals now on our remaining 2010 inventory.**

Transistorized pointless ignition  
 Ideal for sailboats, small tenders



### Engine Service Center

Auxiliary and outboard repair, upgrade & service.  
 Be ready for the season!

POWERED BY

**HONDA  
MARINE**



© 2010 American Honda Motor Co., Inc.

Always wear a personal flotation device while boating and read your owner's manual.  
 5-year warranty standard on all new Honda outboard engines purchased.  
 Check with participating dealers for complete details.

Limited Reps  
Remain!

**Outboard Motor Shop**  
 Where the professionals shop!

(510) 533-9290

www.outboardmotorshop.com

333 Kennedy St., Oakland, CA 94606 • Fax 510-533-3374



Join us for the  
 final 2010 race of our  
**INAUGURAL OFFSHORE SERIES:**  
 Santa Barbara to King Harbor  
 July 30-31

**Ullman  
Sails**

An Investment in Performance

### ULLMAN SAILS LOFTS

#### Newport Beach

(714) 432-1860  
 2710 S. Croddy Way  
 Santa Ana, CA 92704  
 Dave Ullman  
 Bruce Cooper  
 Steve Beck  
 Erik Shampain

#### Ventura

(805) 644-9579  
 3639 E. Harbor Blvd. #111  
 Ventura, CA 93001  
 Gary Swenson  
 Deke Klatt

#### Arizona

Bruce Andress  
 (602) 499-3844

#### Long Beach

(562) 598-9441  
 6400 Marina Drive #9  
 Long Beach, CA  
 90803  
 Bryan Dair  
 Steve Beck  
 (562) 243-9710

#### Santa Barbara

Ken Kieding  
 (805) 965-4538

#### Santa Cruz

Brent Ruhne  
 Ruhne Racing  
 (831) 295-8290 mobile

#### Marina del Rey/ King Harbor

Mike George  
 (310) 645-0196  
 Steve Beck  
 (562) 243-9710

#### San Francisco/ Sausalito

(Racing Sails Only)  
 Robin Sodaro  
 466 Coloma St.  
 Sausalito, CA 94965  
 (415) 332-4117

www.ullmansails.com

# LETTERS

Tom — Ethan Smith, who took the pargo you refer to, was free-diving, as were the two friends he was diving with. Smith is a member of the Long Beach Neptunes, the oldest free-diving club in the country. Of the 34 records that the club lists, 28 of them were set free diving. In fact, scuba gear is not allowed in any of the club's competitions.

It might seem ironic, but we'll bet you a nickel that the members of that club are generally more supportive of conservation efforts than is the general public. These aren't casual



fish-killers, as fish conservation is, among other things, in their best interest. And as you'll note in Smith's letter which follows this, the pargo he shot was one in a school of about 100.

As one who loves to eat fish, it's our opinion that Smith is a more responsible and ethical consumer than we are. For while we and most other people just order our fish from a menu or take it wrapped in plastic from a food store refrigeration case, Smith not only worked hard to get his fish; to a certain extent he put his life on the line getting it. It shames us.

**Believe it or not, Ethan Smith took this monster while free-diving, not scuba diving.**

As for the role cruisers have played in the diminishing fish stocks in the Sea of Cortez and off Mexico, we don't want to

dismiss it entirely, but we honestly think it's minimal. It's our understanding that 50,000 hooks are lowered into the Sea of Cortez each night. How many of those do you think are put down there by cruisers?

### ↑↓ YOUR FAITH WAS JUSTIFIED

I want to thank the publisher of *Latitude* for having faith in me, and to tell him that it was well-placed. In short, the photo of me with the pargo that appeared in the May 24 *Latitude* is genuine, and the fish was real. The additional photos you received, plus the six witnesses who will attest to it, should be enough to convince anyone.

As *Latitude* guessed at the time of the *Latitude* piece, we were in the middle of several weeks of wandering around the Sea of Cortez, and it wasn't until we pulled into the Singlar facility in Santa Rosalia yesterday that I was able to get on the internet. As a result, I'm coming very late to the discussion that the photo I sent might have been doctored.

I have no hard feelings toward LaDonna Bubak, the skeptical *Latitude* editor. I've heard several comments from people who've seen that picture — including my wife — to the effect: "Wow! That hardly looks real!" or, "That's so crazy it looks Photoshopped!" Having seen plenty of pics of guys holding fish in the foreground to make them look larger, and understanding LaDonna's role as a fighter for journalistic truth and justice, I'm not offended at her skepticism.

I also agree with LaDonna that the pargo in the photo looks larger than 75 lbs. I've shot two over 50 pounds, and this fish was much bigger. As for the weight, Thor Temme, whose 45-ft trimaran *Meschach* I was diving from, and I weighed the fish three times on my 50-kg scale. The first two times it caused the scale to throw up — something it does when it is overloaded. Not sure what to think at that point, I took the scale apart, cleaned and reinstalled the batteries, and got a

# Yacht owners can trust **PACIFIC CREST CANVAS** for the best in design, service and quality.

## Still the Highest Quality Products at the Best Prices

### • **Offshore Dodger™**

Welded aft handrail  
Bolt-on side handrails  
Lexan windshields

### • **Baja Awning™**

Lightweight and waterproof  
Durable and easy to launch  
Multiple side screen configurations



Celeste and Don ready for the "Cruising Life" with their new Offshore Dodger and Awning.

### • **Coastal Dodger™**

Affordable designs  
Same high quality materials  
Same superior workmanship

### • **Cruiser's Awning™**

Easy setup off your dodger  
Flies with no bulky frame  
Comes with shade screens

Open Monday-Friday 8:00-4:00  
Saturday by appointment  
**(510) 521-1938**



2021 Alaska Packer Place  
Alameda, CA 94501  
Grand Marina

[www.pacificcrestcanvas.com](http://www.pacificcrestcanvas.com)



## McGinnis Insurance

Since 1972

Knowledge  Commitment  
Reliability  Service



*Large and small, we do them all!*

Call us at: **800-486-4008**  
[meginnsins@aol.com](mailto:meginnsins@aol.com)

License #0570469

West Coast  
Dealers for:



**NEW 2008 C&C 115**  
Hull #76 ~~\$281,781~~  
**CLEARANCE SALE!**  
Save \$50,000!  
**\$231,871**

Well equipped, race package, Ullman Sails, carbon pole & much more...  
Lying Lake Union (fresh water), Seattle, WA. Full 15-year warranty!  
**FREE Delivery to the Bay Area with completed purchase!**

C&C: 99 • 110 • 115 • 121 • 131 (New!)

- 100% Epoxy-Infused Hulls & Decks
- Carbon Fiber Masts
- 15-Year Transferable Warranty

TARTAN: 3400 • 3700 • New! 4000 • 4300 • 4400 DS • 5300 DS



## Marine Servicenter

Seattle • Anacortes, WA  
(206) 323-2405 • (877) 215-0560 (toll free)  
[www.marinesc.com](http://www.marinesc.com)

since 1977

*Outboard Engine Owners:*

## WE UNDERSTAND



When an engine dies, there's no walking home – just costly repairs, lost vacation time, and lost revenues.

**Don't find yourself in this boat. Regular maintenance prevents expensive repairs.**

We are *your* experts for outboard diagnostics, repair, repower, sales and service.



- Factory-trained and certified techs
- Open six days a week
- New and used engines bought and sold
- One-year warranty on all work performed and used engine sales
- Three-year warranty on all new engines

**You will *not* find this knowledge, reputation and network for less.**

## MARINE OUTBOARD

*since 1990*

**OUTBOARD SALES, SERVICE, REPAIR, PARTS**

**(415) 332-8020**

Nissan  
Tohatsu  
Johnson  
Evinrude



Honda  
Mariner  
Mercury  
Yamaha

**35 Libertyship Way • Sausalito, CA 94965**

**Conveniently located at Libertyship Marina**

*If we're not maintaining your outboard, you've missed the boat!*

## LETTERS

weight of a bit over 75 pounds.

As a competitive diver for 14+ years with the Long Beach Neptunes, the oldest free-diving organization in the United States, and someone who dislikes being called a liar, I was loath to submit the fish to the club with a questionable weight. So I chose the lower number. In hindsight, I should have gotten accurate measurements of the fish so I could have used a formula to verify the weight. I personally believe that the fish was much larger than 75 lbs — perhaps even over 100 lbs. In any event, it sure was a grand fish and a great day.

For those who are curious, I took the fish near Roca Corbetena, which is about 15 miles offshore of Punta Mita, which many people know is at the tip of Banderas Bay, Mexico. I was diving with Thor, his friend Michael who was visiting from Hawaii, and their young boys, Tristan, Sasha and Max. While at Tenancatita Bay months earlier, Thor and I had



COURTESY MESHACH

**Ethan's prized pargo likely weighed more than 75 lbs.**

hatched the plan to do a "boys' trip" to Roca Corbetena right after the Banderas Bay Regatta, as Michael, who is also a keen breath-hold spearfisherman, would have a few days before returning home. I suggested Corbetena, as I'd dived it on several times, and knew it to be a good spot for pelagics. Thor agreed to skipper and I agreed to guide, so after the post-regatta party, we took off at 4 a.m. from Paradise Marina. We arrived at the rock mid-morning, and found light wind and seas. It was perfect. Our quarry of choice was yellow fin tuna, and we started out diving a couple of high spots. Michael and I were in the water, while Thor ran the boat 'live', shuttling us up-current each time we drifted through. We found bait, but no tuna or other game fish, so we decided to drift to the rock itself. This was much more interesting, as there was good visibility and lots of bait, as well as large jacks, cabrilla and wahoo. Despite several sightings of the latter, I was unable to get close enough to take one.

After several trips past the rock, and with the boys itching to get back to Punta Mita to do some surfing, Thor and I agreed to one last pass. I was gliding down off a ledge at about 45 feet when a school of 100+/- pargo breezed by unaware below me. I lined up on the largest shoulder I saw and fired, hitting the fish centerline behind the dorsal fin. When that happened, it was off to the races. Happily for me, the fish ran deep. After much huffing and puffing, I was able horse him up before he found a hole to hide in. The kids, fishermen all, went nuts when I swam the fish back to the boat. As for me, I was simply pleased to pull off the hat trick in such fine style!

My thanks to Thor — for the ride and for running the boat.

Ethan Smith  
Eyoni, Ovni 36

Ya Ta Hey, NM / Currently at Santa Rosalia, BCS

*Readers — We asked Ethan for some information about diving for fish in Mexico. He responded as follows:*

*"As far as I know, shooting fish using scuba gear is illegal in Mexico. But as you probably know, that depends on whom you ask and when."*





"I'll be doggone...I forgot my fishing pole and sailing gear!"

# Spud Point Marina

Just 50 miles from the Golden Gate

Want to get away from the traffic, noise and pollution in the Bay Area? Bodega Bay is the place for you (and your boat). Spud Point Marina has berths up to 80' @ \$8 per foot/month...



*Enjoy the Fun, Sun and Salmon in Bodega Bay*

1818 Westshore Road, Bodega Bay 94923 (707) 875-3535  
spudpoint@sonoma-county.org spudpointmarina.org

## Self-Steering and Emergency Rudders

*The Green Solution*



Servo Pendulum with optional emergency rudder  
**BEST FOR MOST BOATS**

**auto-helm**  
windvane

Auxiliary Rudder/Trimtab

**NO LINES – EMERGENCY RUDDER PERFECT FOR DAVITS**

**Say's Rig**

Pendulum trimtab on main rudder

**FOR HYDRAULIC STEERING/HIGH FREEBOARD**

**SOS** Emergency Rudder

**BREAKS DOWN AND STOWS UNDER DECK**

VISIT OUR UPDATED WEBSITE

3,000 BOATS AND MORE THAN 5,000 PHOTOS (added daily)

**www.selfsteer.com**

FACTORY DIRECT

**SCANMAR**  
INTERNATIONAL

432 South 1st St. • Pt. Richmond, CA 94804

Tel: 510 215-2010 • Fax: 510 215-5005

Toll Free: 888-WINDVANE (946-3826)

email: scanmar@selfsteer.com

## THINK

*Just say no to boxy dodgers!*

**BEFORE:**  
The Box



**AFTER:**  
Beyond the Box



**STARBUCK**



**CANVAS WORKS**

67 Liberty Ship Way  
Sausalito, CA 94965

**415•332•2509**

## WHATEVER YOU'RE RACING, WE'LL ALWAYS FOCUS ON FIVE CRITICAL COMPONENTS THAT MAKE A WINNING SAILPLAN.



1) The right high-technology construction for your individual requirements. 2) Optimization so your rating isn't working against you. 3) Durability: sails that last make every victory sweeter. 4) Personal service from sailmakers (not salesman). 5) Reasonable pricing because, if you can't afford good sails, the race is over before you start. Call and let us focus on you.



510-523-3966 ukhalsey.com

## Secure Your Assets

- Ultra Anchors
- Quickline Flat Rope & Reel
- Ultra Swivels
- Ultra Trip Hooks
- Ultra Chain Grabs, Ultra Snubbers & Ultra Bridles

www.quickline.us  
**QUICKLINE**

The Best Marine Products from the World, for the USA.

www.UltraAnchors.us • sales@quickline.us or 714-843-6964

## LETTERS

"Free divers are capable of taking large fish. This includes a 545-lb giant sea bass taken by Bob Stanbery at Santa Cruz Island in '68, and a 425-lb shortfin mako taken by C. Steward Graham off the Coronado Islands in '99.

"When I go for large pelagics, I use a 70-ft Norprene bungie, which acts like a drag on a fishing reel, one or two inflatable or



COURTESY MESHACH

foam-filled floats, and a four or five-band custom-built speargun which fires an 11/32 x 65-inch shaft. Each rubber pulls something like 75 lbs. I rig the shaft with a 3/16-inch stainless cable shootline of just over 20 feet in length, and use a

### One last piece of photographic evidence.

6-inch Morfish speartip that 'breaks away' from the tip of the shaft on 1,000-lb Spectra cord. This is the cord you can see exiting the fish's back in the pargo picture. A slide-ring slips along the shaft to keep the shaft and tip attached. The tip toggles into or on the far side of the fish, then detaches from the shaft. This prevents the shaft's becoming a lever and either ripping out or bending. This rig is ideal for wahoo, amberjack, yellowfin and so forth. I use a vinyl float-line for reef fishing, as Norprene is expensive and not abrasion-resistant.

"While I usually horse grouper and pargo up to the surface to keep them from holing up on the bottom, this particular fish made a freight train rush to the bottom. So after a bit of tug 'o war, I ascended my float-line to the floats. Each float has about 40 lbs of flotation. The first float was completely underwater, and the second was half submerged. I straddled them like a pool noodle, and began hauling the big fish up.

"My shot had been a good one, with the tip toggled under the spine. So after the first long run, I was able to make pretty good progress getting him up. After he was up to the cable shoot line, I clipped the fish off to my buoy with a long-line clip. Then I dove down, tackled him in a bear hug, and stuck him in the brain.

"I'm happy to share the intimate details, although based on experience I'm concerned how those who have mindlessly divorced predation, and even death, from their styro-trayed, meat-section delicacies, might respond."

### ↑↓ "I STILL SAY IT'S PHOTOSHOP"

Despite the additional photos of the pargo, and the claims that it's for real, I still think it was Photoshopped. In the first photo, the right side of the man's head and body is in the shade, but the same side of the fish is in the sunlight. Similarly, in the third picture, the one of the fish on the boat with the kids, the fish has no visible means of support. It's in semi-upright position and the shadow of the man's left leg on the deck stops at the fish. In other words, the fish covers the shadow of his leg.

### Rennie's entry in the Latitude Fishing Derby.

And here's another reason I think it's been Photoshopped. As others have pointed out, it looks too big to be 75 lbs. This wahoo, caught on *Cassiopeia* during

COURTESY CASSIOPEIA

50' Monthly Rent \$452.50

# Own a dock on San Francisco Bay! Perfect Location - Great Investment

**EMERY COVE**  
YACHT HARBOR

**BUY A SLIP** – Save money & earn equity! Save 1/3 of your rental cost. Enjoy big tax savings as a slip owner. Emery Cove Yacht Harbor is the only marina on the Bay with FEE SIMPLE (not a grounds lease) dockminium ownership.  
**OR RENT A SLIP** – 35-60' slips, rates from \$8.80 to \$9.80.  
**MARINA GUARD®** – Cutting edge electrical ground fault monitoring system.  
**WIRELESS INTERNET** – Free

Mathiesen Marine  
Michael Wiest Yacht Sales  
Emeryville Yacht Club  
on premises



**CALL FOR A MARKETING PACKAGE • 510-428-0505**  
3300 Powell Street, Emeryville, CA 94608 • [www.emerycove.com](http://www.emerycove.com) • Email: [info@emerycove.com](mailto:info@emerycove.com)

## BETA MARINE WEST

### Beta Marine Diesel Engines and Generators

- With Dealers in:
- Los Angeles
  - San Pedro
  - Wilmington
  - Santa Barbara
  - Newport Beach
  - Morro Bay
  - Ventura
  - San Diego
  - Hawaii

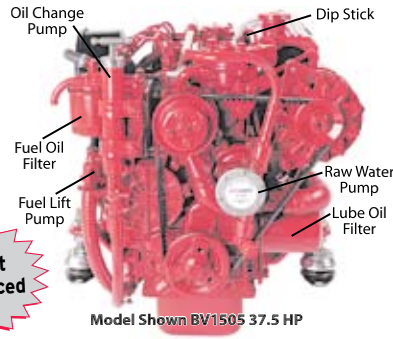

The engine that can be serviced easily!

### HIRSCHFELD YACHT LLC Marine Repair and Installation Specialists Full Service Shop with Dockside Access

- |            |                   |               |
|------------|-------------------|---------------|
| Electrical | Engines           | Outdrives     |
| Generators | Inboard/Outboards | Propellers    |
| Controls   | Installation      | Transmissions |

[www.betamarinewest.com](http://www.betamarinewest.com)

**415-332-3507**

39 Liberty Ship Way, Sausalito 94965



## shadetree fabric shelters

Sun/Rain awning, self supported, no halyard. Rigid, folding, flexible frame. "Stands on lifeline". Waterproof, marine grade construction throughout. Easy up & down. Stows complete in 10"x36" bag. Designed for use in true cruising conditions. Stock models for up to 50ft LOA \$300-\$800. Custom designs also available.

[www.shadetreefabricshelters.com](http://www.shadetreefabricshelters.com)

email: [info@shadetreefabricshelters.com](mailto:info@shadetreefabricshelters.com)

1-888-684-3743 1-251-987-1229

# AIS Made Easy!

Latest, most cost-effective collision-avoidance solution

AIS (Automatic Identification System) receivers enable AIS-capable chart plotters and navigation software to see other vessels. AIS transponders allow other vessels to see you.

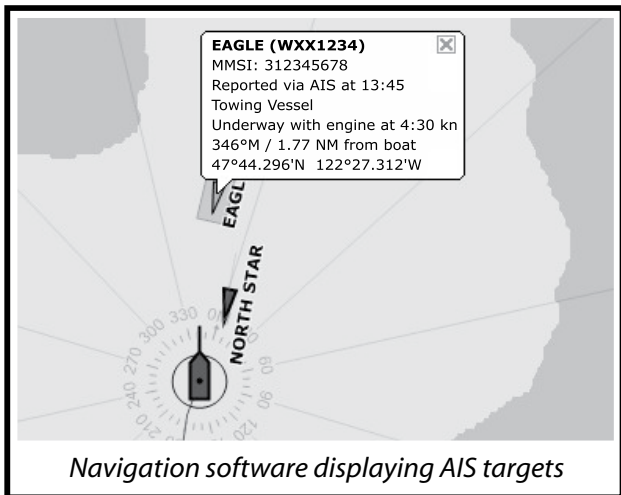

Milltech Marine offers complete, low-cost AIS solutions. Visit our web site for information on:

- ✿ AIS Receivers - featuring the Comar AIS-MULTI
- ✿ AIS Transponders - including Class B AIS
- ✿ Navigation Software
- ✿ Antennas, cables and other accessories



Order any product online and use coupon code "LAT38" to get free shipping in the U.S.

For more information contact:



(866) 606-6143  
www.MilltechMarine.com

## LETTERS

the '03 Ha-Ha was 75 lbs. The pargo looks much larger.

Rennie Waxlax  
ex-Cassiopeia, Swan 65  
San Pedro

### ↑↓ "LOOKS REAL TO ME"

Ethan's Smith's pargo looks real to me, and I've been a captain of a charter fishing boat for 40 years. When people are getting their photos taken with their fish, I always tell them to hold the fish as far in front of them as possible, because it makes the fish look bigger.

Bruce Paty  
Planet Earth

### ↑↓ HOW'S THIS FOR A FISH?

You asked for photos of fish caught while sailing. I caught the mahi mahi in the accompanying photo while sailing in Fijian waters. I'm not sure of the size or weight, but I do know that it fed us for a few days. And you should have seen the size of the one that got away!



Matthew Matson  
Aeventyr,  
Tayana 37  
Seattle / Currently in the  
South China Sea

### ↑↓ OR THIS?

I don't know the weight of the mahi in the accompanying photo, but we guessed it to be

Matthew's entry . . . . . and Bill's.

around 45 lbs. As I recall, it was 54 inches long. We caught it three hours out of Muertos on the way over from Mazatlan. It just so happens that we were having a fishing derby with the folks on *Just A Minute* when we landed it.

Bill Houlihan  
Sun Baby, Lagoon 41  
San Diego

### ↑↓ MARLIN FROM A SAILBOAT

The accompanying photo is of Marina Village Harbormaster Alan Weaver landing a marlin off the back of *Escapade* off Bermuda. It was catch 'n' release.



Greg Dorland  
Escapade, Catana 52  
Lake Tahoe

So far, Alan's in the lead for this marlin.

Readers — We received a lot more photos of fish caught from sailboats, and hope to run more of them in future issues as space permits.

### ↑↓ IT WAS A HELLUVA RIDE!

Congratulations to Bill Turpin and the crew of the R/P 77 *Akela* for a very impressive sail in the Spinnaker Cup from San Francisco to Monterey. Reading about it reminded me of the '83 Midget Ocean Racing Association (MORA) race from

WE  
WORK  
SO  
YOU  
CAN  
PLAY!



BEFORE



AFTER

FULL  
SERVICE  
SHOP  
WITH  
DOCK  
ACCESS



## BAY AREA BOAT WORKS

25 THIRD STREET  
SAN RAFAEL  
(415) 454-BOAT (2628)  
INFO@BAYAREABOATWORKS.COM

[www.BayAreaBoatWorks.com](http://www.BayAreaBoatWorks.com)



WE BRING THE BOAT  
YARD TO YOU!



## FULL SERVICE MOBILE RIGGING

- *Competitive Rates*
- *Firm labor quotes on most projects*
- *17 years experience*



Call John Hansen



Alameda  
(510)815-4420

[yachtcheck@yahoo.com](mailto:yachtcheck@yahoo.com)

COVER CRAFT

## DURABLE GOODS

Better Materials  
Thoughtful, Innovative Designs  
Top Quality Workmanship



All sewing in Tenara thread

- Classic dodgers and biminis
- Drop-top folding dodgers
- Enclosures • Custom canvas

1230 Brickyard Cove Road, #106  
Pt. Richmond, CA 94801  
In Brickyard Cove Marina

**(510) 234-4400**

Quality  
Yacht  
Canvas

**YOUR DISCOUNT MAXWELL SOURCE!**

## Freedom RC-800 Series Windlass Kit

- Automatic rope/chain windlass
- For boats up to 45'
- Accepts 5/16" G4 hi-test chain and 5/8" line
- Includes 1000W motor, up and down switch, breaker, solenoid and handle



List \$1343.00  
Reg \$679.99

★ 000998

While Supplies Last!

Now only **\$549<sup>99</sup>**

Most Orders Placed by 4pm Ship the Same Day!

# Defender®

[www.defender.com](http://www.defender.com)

800-628-8225 • [info@defender.com](mailto:info@defender.com)

THE BRANDS YOU WANT AND TRUST IN STOCK FOR LESS **FREE Catalog!**



## Let Hydrovane sail you home safely.



▲ Polar circumnavigator Adrian Flanagan.



Latest ARC survey –  
Hydrovane again the  
most popular wind vane.

Totally independent  
self-steering system and  
emergency rudder...  
in place and ready to go.



LATITUDE / RICHARD



SURVIVE YOUR DREAM

[info@hydrovane.com](mailto:info@hydrovane.com) PHONE 1.604.925.2660

## LETTERS

San Francisco to Monterey I did with David Hodges, Ian Klitza and Jay Crum on the Wilderness 30 *Special Edition*. We sailed the course in 8 h, 35 m. To be sure, that's about an hour and 25 minutes longer than it took *Akela*, but *Special Edition* is less than half as long as *Akela*.

As I recall, we had a noon start, which I found frustrating because we wanted a shot at finishing before sunset. As it was, we didn't get the kite up until we were down by Half Moon Bay. But the breeze just kept clocking and building. At one point, I remember looking back and seeing the boat behind us pitchpole. The boat behind them dropped their chute and winged out a jib. But *Special Ed* could still profitably carry our fractional 1.5-oz chute, a sail Ian always referred to as 'the potato chip'. The adrenaline was flowing pretty strong as we blasted down Monterey Bay.

We finished at 8:35 p.m., which was just about sunset. It had been a hell of a ride!

Eric Sultan  
Osprey, Santa Cruz 40  
Alameda

*Eric — A young Hodges, Klitza, Crum and Sultan on a 30-ft ultralight — one can only imagine what that must have been like.*

### ↑↓ WORDS OF EXPERIENCE

Having just received our latest *Latitude* here on South Maui, I really enjoyed reading the article about other folks' experiences with the Crew List. I'd like to add my thoughts for those who may be picking up *Latitude* for one of the first times and wondering how to get into the wonderful world of sailing.

I grew up as a backpacker and mountaineer in the Sierra, and started sailing almost three decades ago with my dad's senior citizen group, which sailed out of the Alameda Naval Air Station. They jokingly called themselves the Orinda YC. One

day one of them handed me a *Latitude* and said, "I think you'll like this." After reading it cover-to-cover, and seeing all of the stories and pictures about sailors obviously having the time of their lives, I wrote a letter to the editor. It essentially asked, 'Where do I sign up?' and was published. The Editor/Publisher/Wanderer/Grand Poobah very patiently wrote a long reply back

**Bird loving 'Profligate' crew Patrick Ralph has also had great success using the 'Latitude' Crew List.**

and advised me to go for it, to walk the docks — still possible then — sail in beer can races, hang out at the yacht clubs after the races, and above all, sign up for the Crew List.

To make a long story short, I followed his advice, and had many, many great sails and cruising experiences, both from the Crew List parties and from hanging out at yacht and sailing clubs. Over a decade, things came full circle, from my asking, "Where do I sign up?" to my being featured in the pages of the magazine.

As the popular Hawaiian surfing song goes, "If I can do it, so can you!" So if you're out there wondering how to get into this incredible world of sailing and cruising, look no further than *Latitude*, the *Latitude* Crew List, the Crew List Parties,

# Z BLOK WON'T BURN YOUR EYES



Z Blok sunscreen's new non-greasy formula will not burn or irritate your eyes. So you can concentrate on winning the race or just enjoying a great day on the water. Z Blok is also fragrance free.

Z Blok is the official sunscreen of the PUMA Ocean Racing Team. Skipper Kenny Read said:

"The UV protection is excellent. The entire team is true believers. We have put the sunscreen to a tough test that few others can. More importantly, we have experienced no eye stinging or irritation and we use it every day."

Z Blok is available at:

**Coast Chandlery**  
Oxnard

**Sailing Supply, Inc.**  
San Diego

**The Ships Store**  
Marina Del Rey

**Sailing Pro Shop**  
Long Beach

**Svensen's Marine**  
Alameda

**zbloksun.com**



## VERY ENGAGING.

Our new Fast Entry Cam Cleats with a hardcoat anodized finish have a raised base and flared jaws to make it much easier to quickly engage your line from a wider range of angles. Heavy duty stainless steel springs and Delrin ball bearings assure reliable service over the long run.

**SCHAEFER**  
LEGENDARY STRENGTH

508.995.9511  
SCHAEFERMARINE.COM

## Advanced LED Navigation Lighting



Super Bright  
Waterproof  
Multiple Color Configurations  
Excellent Viewing Angles  
Lifetime Warranty

Available at:  **SVENDSEN'S MARINE**

Call or visit our website to learn more about our quality lighting products.

www.LunaseaLighting.com  
1.800.272.0170

RoHS compliant   



***MORE FUN! MORE FUN!***  
**Tradewinds will be hosting the**  
**Catalina Rendezvous July 16-18 and**  
**Delta Doo Dah Deux July 30th**  
**at our Clubhouse.**



For information on July 2010 ASA sailing classes and our unlimited-sailing membership, visit ***www.TradewindsSailing.com.***

***Tradewinds Sailing School and Club***

***More Experience. More Time on the Water. More Fun.***

**2580 Spinnaker Way, Richmond, CA 94804, (510) 232-7999**

# Hogin Sails = One Design

**Congratulations to Mark Lowry and his 'Xena' crew on their victory in this year's Elite Keel. Hogin Sails has been building custom racing sails for the Express 27 fleet.**

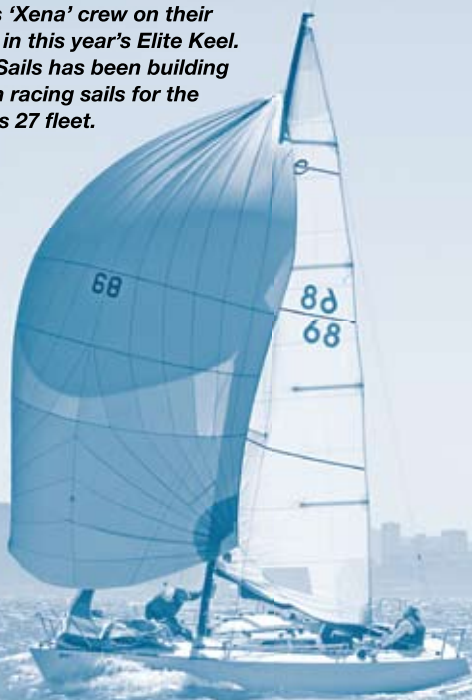

**Express 27**  
THE ULTIMATE SAILING MACHINE

**Call us today to discuss how we can help improve your performance.**

Keep racing with  
**HOGIN SAILS**



- New racing or cruising sails
- Roller furling conversions
- All sails manufactured at our Alameda loft
- Repair and service
- Boom and canvas covers
- ATN spinnaker/genoa sleeves

In the Alameda Marina at  
1801-D Clement Ave., Alameda, CA 94501

**510.523.4388**

Mon-Fri 8:30am to 5pm  
Saturday by appointment only

sales@hoginsails.com  
service@hoginsails.com  
www.hoginsails.com

## LETTERS

and the great yacht and sailing clubs around the Bay and beyond. Trust me, there are boatowners out there who would love to have you aboard, even as a rank beginner.

Mark Joiner  
Dolphin  
Wailea, Maui

*Readers — If you make an effort, the things Mark recommends do work. Patrick Ralph of Benicia recently did a Baja Bash aboard Profligate. He told us that he's gotten 20 rides from the Crew List, including the last two Ha-Ha's and the last two Pacific Puddle Jumps.*

### ↑↓ NO PRE-MEXICO PAPERWORK NECESSARY

I met the Grand Poobah and Doña de Mallorca briefly at the '98 Ha-Ha Crew List Party at the Encinal YC. I opted not to be a part of the Ha-Ha, as it moved south too fast for me, but I did spend the '98-'99 season cruising in Mexico.

I'm now hoping to spend the '10-'11 season cruising in Mexico. My current home port is Eureka, and I'm wondering if I have to go to a Mexican consulate before sailing to Mexico. If I do, do you know of a service that can take care of the paperwork for me? I'd prefer to avoid having to make an expensive trip to the consulate in either Sacramento or San Francisco.

This time my cruising plan is to not stop anywhere north of Mazatlan, except possibly to anchor or rest overnight. And on my way down, I wish to avoid San Francisco and San Diego entirely. What are my options?

David Carr  
Flying Cloud, Yorktown 35  
Eureka

*David — You have nothing to worry about. There is no paperwork that needs to be done prior to clearing in at a Mexican port of entry, and when you get to one, all you need is your boat registration or documentation and a passport for everyone on your boat.*

*Mexican ports of entry on the way to Mazatlan include Ensenada, Cedros, San Carlos and Cabo. To date, Mexican officials haven't expressed any concern with boats stopping overnight in Mexican waters prior to clearing in at a port of entry. For instance, the Ha-Ha fleet stops at both Turtle Bay and Bahia Santa Maria prior to clearing in at Cabo. But you don't want to push it.*

*For answers to these and many other questions about cruising in Mexico, visit Latitude 38's First Timer's Guide to Cruising Mexico. It can be found and downloaded for free at [www.baja-haha.com](http://www.baja-haha.com).*

### ↑↓ THE COSTS OF CHARTERING 'TI PROFLIGATE

I just read the June *Sightings* piece on the Leopard 45 catamaran the publisher of *Latitude* has in a yacht management program in the British Virgin Islands, and how well it's worked for him over the last three years. That's very interesting, and it may be something I'd like to get into in a few years. But for right now, I'm curious what a Leopard 45 cat — which I understand has four cabins with four heads en suite — costs to charter for a week in a second-tier yacht charter program.

Tony Scarlino  
Tempe

*Tony — All we can tell you is what our '00 Leopard 45 'ti Profligate charts for from BVI Yacht Charters. In the off*



# NORSTAR YACHTS

BELLINGHAM, WA

# NORSTAR 44

DESIGNER: ROBERT H. PERRY

HEAD TURNING GOOD LOOKS  
LUXURIOUS INTERIORS  
SOLID SAFE PERFORMANCE

OFFSHORE CRUISING YACHTS

NORSTAR 40

NORSTAR 44

NORSTAR 46

WWW.NORSTARYACHTS.COM ♦ SALES@NORSTARYACHTS.COM ♦ 360 223-2399

## THE RELIABILITY'S BUILT IN!

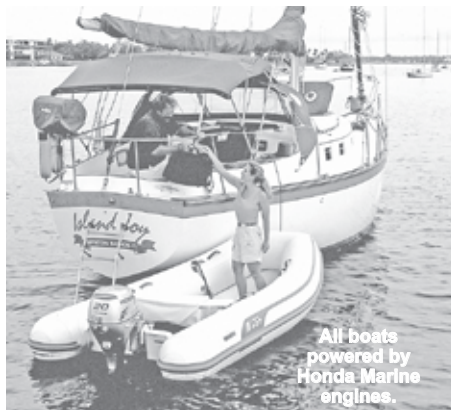

All boats powered by Honda Marine engines.

**HONDA**  
**MARINE**  
PROVEN



We offer complete service on all Honda outboards and inflatable boats and take pride in providing the kind of customer satisfaction that you expect from Honda.



**The Dinghy Doctor**  
1271 Scott Street  
San Diego, CA 92106  
Tues-Sat, 9am-5pm  
**(619) 804-6921**  
www.thedinghydoctor.com

2 blocks off Shelter Island

AB, Achilles, Zodiac, Walker Bay, repair kits, engine parts, and everything you will need in Mexico.

Always wear a personal flotation device while boating and read your owner's manual.

### BF20

- Unsurpassed fuel economy
- Shallow water drive
- Largest displacement in its class (21.4 CI)
- Hi Output alternator (12 amps)

# SEA SHINE

## MORE SAILING, LESS WORK

### Service of the Month POLISHING & DETAILING

Shiny summer sailing. Our polish and detail service will protect your boat and get it looking great!

### ADDITIONAL SERVICES

- Bilge Cleaning
- Detailing
- Maintenance Washdown
- Carpet & Cushion Cleaning

**Fully Insured & Marina Approved**

*Since 1986*

**Call now for a Free Estimate**

(510) 428-2522 or (415) 457-6300

www.seashine.net

## RIGGING HARDWARE

For the seriously safe sailor!



Whether you're a fair-weather sailor or regularly challenge the world's oceans, we know that safety, strength and reliability are of premium importance in your choice of rigging hardware. Sta-Lok takes these qualities seriously too, which is why we're one of the leaders in our field. So next time you're enjoying a summer breeze or battling a winter gale, **don't leave it to chance – leave it to Sta-Lok!**



**STA-LOK®**

**Sta-Lok Terminals Inc.**

(910) 399-5206

[www.stalokinc.com](http://www.stalokinc.com) [info@stalokinc.com](mailto:info@stalokinc.com)

2725-1B Old Wrightsboro Road, Wilmington, NC 28405

## LETTERS

season, which is August 1 through October 31, she goes out for \$4,350 a week, taking a maximum of eight passengers. In the low season, which is May 1 to July 31, and November 1 to December 14, she goes out for \$4,995. In the mid season, which is January 6 to January 21, and April 1 to April 30, she goes for \$5,750. And in high season, she goes for \$6,550 a week.

In our opinion, the start of low season, meaning May 1, is a really good 'big bang for the buck' time, as is the end of low season — although 'ti Profligate is already booked for that period this year. For those needing to escape really cold climes, we also recommend the January 6 to January 21 mid season period.

Another thing to keep in mind is that the Leopard 45 is all but the exact same boat as the Leopard 47, except the 47s have a two-ft sugar scoop on each hull, generators, and sometimes air conditioners. For those three extra things you pay another \$1,700 to \$2,000 per week. To each their own, but we'd rather have the extra money.

We hate to sound like used car dealers, but if you want to charter 'ti Profligate, don't wait too long, because she's a very busy cat and is rapidly booking up. But remember, our cat and BVI Yacht Charters certainly aren't the only games in town. Call around to find the right boat and deal for you. Others you might contact are TMM Yacht Charters, CYOA Yacht Charters, Foot-

loose Sailing Charters and Conch Charters, all of whom advertise in Latitude.



LATITUDE / RICHARD

For folks with bigger budgets and looking for more room and luxury, the Lagoon 440s and the Leopard 460s, available from different charter outfits, are two of the more popular and attractive options. Both have elevated helm stations, and the latter even have electric toilets — something the ladies swoon over. No matter what boat you choose to charter, and no matter what charter outfit she's from, we're pretty sure you'll have a fabulous time.

'ti Profligate's dance card is full for the low season.

### ↑↓ DON'T EVEN THINK ABOUT IT IN CALIFORNIA

I intend to bring my Alberg 30 from the Chesapeake to the San Diego area later this year to prepare for the sail home to Australia. I'm having trouble finding a marina where I can live on and work on my boat while I get ready to leave, and also have her hauled. Can you help me?

Owen Zeimer  
Planet Earth

Owen — Harbormasters in San Diego — and most places in California — tell us there are plenty of 30-ft slips available. But you may be frightening them away by saying you want to live and work on your boat, too. Liveaboard slips are in short supply everywhere, and a harbormaster's nightmare is that one of his docks will become a floating boatyard.

Our advice is to truck your boat out here to a yard where you can get all the messy exterior work taken care of. Then present your nice-looking boat, your nice-looking self, and your truthful situation to a harbormaster in person. If you look as though you'll be a credit to the marina, some harbormasters will be more flexible with bending the rules or turning a blind

**METTEC**  
TITANIUM FASTENERS & PRODUCTS

**IMPROVES BOAT SPEED  
HALF THE WEIGHT OF STAINLESS STEEL**

BY USING TITANIUM FASTENERS YOU OBTAIN THE FOLLOWING ADVANTAGES:

- Cheaper than stainless steel over time.
- Reduced boat displacement.
- Reduced tipping moment.
- Non corrosive - more corrosion resistant than stainless steel.
- Carbon fiber compatible.
- Durable and reusable.
- High strength levels - minimum ultimate tensile strength 130-190ksi.

Carson City Nevada, USA (775) 246-8200  
[WWW.METTEC.COM](http://WWW.METTEC.COM)

# Designed to the max

470 > 320 350 New375 400 430 New545 630e [www.hanseyachts.com](http://www.hanseyachts.com)

**Compare our pricing against the competition**

- ▲ Ground breaking interior design
- ▲ Self-tacking jib engineered into the HanseYachts design
- ▲ Multiple layout options (Individual Cabin Concept)
- ▲ Epoxy hulls (option up to 54 ft)
- ▲ Modern, award winning performance cruisers
- ▲ Safe, comfortable, fast & easy to sail

**Hanse Yachts US** | Ph: 1-410-571-5881 | [aharrison@hanseyachts.com](mailto:aharrison@hanseyachts.com)  
 Annapolis MD | Norwalk CT | Manchester MA | Huron OH | Chicago | Toronto Montreal |  
 Vancouver | San Francisco | San Diego | St. Petersburg FL

*Hanse*   
 A BRAND OF THE HANSEGROUP

## West Marine® Rigging Service

### Your Sailing Resource!

- Specialty Hardware • Technical Apparel

**Mobile Rigging Service Available**

**Complete Rigging Headquarters!**  
 Installation • Lifelines • Running Rigging  
 Standing Rigging • Dock & Anchor Lines

**Contact us for all of your Rigging Needs!**  
**888-447-RIGG**  
 or visit our Onsite Rigging Locations in:

<b>San Diego, CA</b> 1250 Rosecrans St. (619) 255-8844	<b>Alameda, CA</b> 730 Buena Vista Ave. (510) 521-4865	<b>Seattle, WA</b> 1275 Westlake Ave. N (206) 926-0361
--	--	--

[westmarine.com/rigging](http://westmarine.com/rigging)

Now in our 42nd year!

Dear Travis and Colin:  
 We've had a wonderful summer of sailing...and have received numerous compliments on the sails, Mack-Packs, boat. We've done a bit of racing and, after a classic boat race, one competitor (a sailmaker in Seattle) said he was really impressed with our sails...  
 (happy Port Townsend customer)

**All Mack Sails are Built to Last  
 ...and designed to be Fast**

Every Mack Sail is Made in Our Stuart, Fla. Sail Loft

Colin Mack and Travis Blain  
 Partners in Mack Sails

High Quality and Great Customer Service  
 Have Certainly Made Mack Sails...

**the Biggest Small Loft in the USA**

<b>MACK SAILS</b>	3129 SE DOMINICA TERR. STUART, FL 34997 (772) 283-2306 FAX (772) 283-2433	(800) 428-1384 (772) 283-2306 <a href="mailto:INFO@MACKSAILS.COM">INFO@MACKSAILS.COM</a> <a href="http://WWW.MACKSAILS.COM">WWW.MACKSAILS.COM</a>
-------------------	--	--

Also See Us for Rigging, Hardware and Electronics --- We Ship Everywhere



# SVENDSEN'S METAL WORKS

Our expert metalworkers specialize in the design and fabrication of custom pieces.

This spiral staircase was designed and created for a recent customer. The space was small and the staircase had to be functional and attractive yet take up as little room as possible.

The finished piece has a clean, elegant look, with 'floating' steps inlaid to match the main salon's new floor.



Above: Spiral staircase installed in main salon



Right: Top view, showing inlaid treads

This is just one example of the kind of pieces Svendsen's Metal Works can make for your boat. From staircases to custom flagpoles, brackets to railings, motor mounts to solar panel racks, custom designs are our specialty – and customer satisfaction our #1 priority. Call for your free estimate today.

## 510.864.7208

In the Alameda Marina | [svendsens.com](http://svendsens.com)

## LETTERS

*eye to minor infractions.*

*If you're going to want or need to do more extensive work on your boat, we suggest that you truck her to San Diego, then sail her to Mexico and take up residence in one of the second-tier marinas that allow owners to live and do work on their boats.*

### ↑↓ WISHING I WAS THERE

From the shores of Central America to the walls of New Folsom Prison, where I am now, I've always looked forward to reading what is going on in the sailing community — and



DARIN BAUER

### Darin's halfway to being free as the wind.

*Latitude never lets me down. I do want to make an observation about the term "cruisers' remorse," though. In light of the piss-poor decision that got me here, I'd have to say that I suffer more from the affliction of "returner's remorse." No doubt I deserve my punishment, and less doubtedly I look forward to open waters once and forever more. Seven years down and six to go — I'll be seeing you in Pura Vida!*

*Latitude never lets me down. I do want to make an observation about the term "cruisers' remorse," though. In light of the piss-poor decision that got me here, I'd have to say that I suffer more from the affliction of "returner's remorse." No doubt I deserve my punishment, and less doubtedly I look forward to open waters once and forever more. Seven years down and six to go — I'll be seeing you in Pura Vida!*

Darin Bauer  
Stupid Gringo  
New Folsom Prison

*Darin — You're more than halfway there and seem to have the right attitude. We wish you the best of luck.*

### ↑↓ THINKING RATIONALLY WHILE PANICKING

My condolences to the family and friends of Dave Gish, who drowned in Ventura West Marina. My husband and I kept our sailboat at Ventura West Marina for over 20 years, so I speak from direct knowledge. All anyone who goes into the water in a small harbor like Ventura needs to do is swim/paddle to the shore and climb out on the rocks. No ladders are necessary, just common sense.

Linda Dacon  
Bettina, 41-ft Laurent Giles sloop  
Pt. Townsend, Washington

*Linda — That's a good point, and certainly something for everyone who keeps a boat in a marina with a gradually sloped embankment to keep in mind. On the other hand, we used to keep our Freya 39 at Ventura West, and if a fully clothed person fell into the chilly waters near the end of the dock, it could be a pretty difficult swim to the embankment. At a time like that, common sense is often replaced with panic. We think the important thing is that everybody have a get-out-of-the-water plan in advance.*

*In a typical month, we receive a tremendous volume of letters. So if yours hasn't appeared, don't give up hope.*

*We welcome all letters that are of interest to sailors. Please include your name, your boat's name, hailing port, and, if possible, a way to contact you for clarifications.*

*By far the best way to send letters is to email them to [richard@latitude38.com](mailto:richard@latitude38.com). You can also mail them to 15 Locust, Mill Valley, CA, 94941, or fax them to (415) 383-5816.*



Beautiful 20 acre greenbelt park in the Heart of the Delta

- Up to 30' no power/inside tie @ \$4.50 per foot
- 30'- 50' berths @ \$5.50 per foot
- Home of Andreas Cove Yacht Club

Located on Seven Mile Slough, just off the San Joaquin River

1550 W. Twitchell Island Road • Isleton, CA 95641  
916.777.6055 • [www.owlharbor.com](http://www.owlharbor.com)

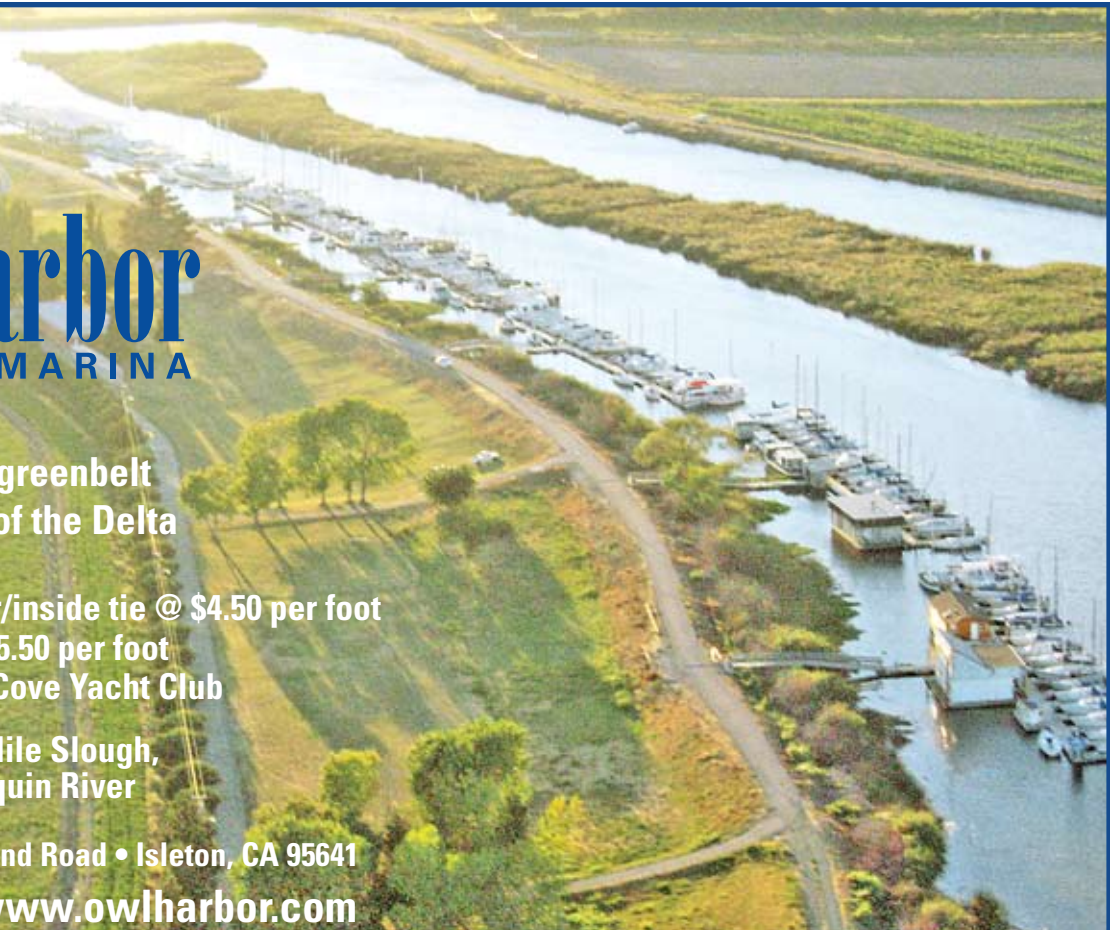

FREE QUOTES

**10,000 SAILS  
IN STOCK**

[www.BaconSails.com](http://www.BaconSails.com)

Search online – list updated daily

**BACON SAILS AND MARINE SUPPLIES**

116 Legion Avenue Annapolis MD 21401  
(410) 263-4880

**McDERMOTT COSTA**

insurance brokers - est. 1938

**Commercial  
Operations**

- COMMERCIAL POLICIES  
Marinas, Yards,  
Yacht Clubs,  
Brokers,  
Shipwrights

**Pleasure  
Yachting**

- YACHT & BOAT POLICIES  
Offshore, Coastal,  
Inland and  
Liveboards



Lic. #OB21939

**Bill Fowler**

McDERMOTT COSTA INSURANCE  
(925) 606-6606 Fax (510) 357-3230  
[bfowler@mcdermottcosta.com](mailto:bfowler@mcdermottcosta.com)



## Afterguard Sailing Academy

www.afterguard.net Oakland CA

(510) 535-1954



### Women's Classes



Get ASA certified with Afterguard – Call today to jump-start a whole new Sailing Lifestyle.



### Charter & Cruise Prep



Did/does the person you've sailed with have a square mouth?  
**Afterguard, the fun, 'No Yelling' School on SF Bay**

# LOOSE LIPS

Eight bells.

We've often observed that the most unassuming people — those who toot their own horn the least — have actually accomplished great things in life. That was certainly true of our old friend Gerry Cunningham. For years we'd known him simply as a kindly old guy who showed up at boat shows and Baja Ha-Ha parties offering cruising guides of the Sea of Cortez — but never with a hard-sell attitude — before realizing that we had a personal connection to him that went back decades. Turns out he was the designer and maker of the original internal-frame backpack, one of which rode on our shoulders twice around Europe, and all through Central and South America during the '70s.

And it wasn't until after his passing on May 15, at age 88, that we learned his revolutionary, lightweight, Gerry brand camping gear and "leave no trace" attitude had been instrumental in transforming wilderness camping into an accessible family sport.

His mountaineering gear was also used on many major climbing expeditions during the '50s and early '60s including the 1953 American K2 expedition and the first successful American expedition to Everest in '63. He

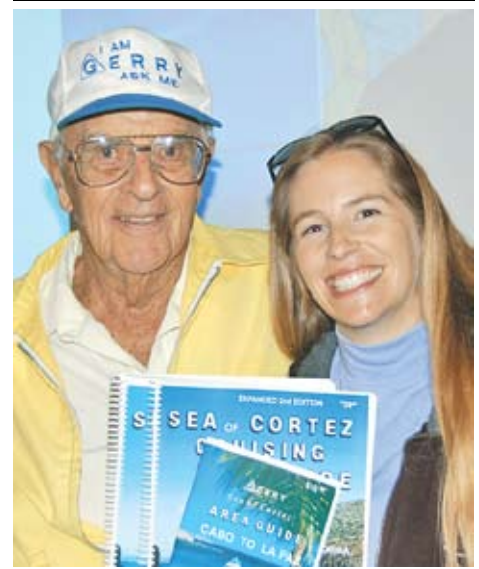

LATITUDE / LADONNA

*For many, Gerry Cunningham was the guy selling great cruising guides at boat shows with his pretty granddaughter Heather. In reality, he was so much more, and we'll miss him.*

later designed the now-ubiquitous spring-loaded drawstring clamp found on all sorts of outdoor gear, and a variety of other gadgets and gear items.

A World War II veteran of the 10th Mountain Division, Gerry moved to Colorado after the war which kindled his interest in mountaineering, just as his later move to Arizona sparked his passion for exploring every anchorage and cove in the nearby Sea of Cortez. Up until the end, he strove to make his charts as accurate as possible, and he was the first — we believe — to offer GPS-corrected versions. His company, Gerry Sea of Cortez Charts, will continue on, managed by family members.

Even during their early days together at Antioch College, Gerry and his wife Ann (who passed away last year) were way ahead of their time in terms of social consciousness. Back then, they dreamed of building a log cabin and living off the grid. Together they built four highly energy-efficient homes in Colorado and Arizona, mostly by hand. For the past 30 years, they'd lived comfortably in earth-sheltered concrete domes powered only by solar electricity. During Governor Bruce Babbitt's administration, Gerry was appointed Arizona's director of Energy Programs.

The affable outdoorsman is survived by three children, five grandchildren, seven great-grandchildren, and one great-great-grandson. Donations in his memory may be made to the Nature Conservancy. Gerry was one of a kind, and we're sure going to miss him.

— andy



Hobie

# ENJOY THE RIDE

Hobie is thrilled to introduce an exciting new member of our fleet.

The Hobie Mirage Tandem Island is the big brother of our Hobie Mirage Adventure Island and twice the fun. Plenty of room for the skipper and crew, with total control of the roller furling sail and the large Twist and Stow rudder from either high back padded seat. Inspired by Polynesian multihulls, this 18' 6" trimaran "sail-yak" includes state-of-the-art features and comfort, plus two patented MirageDrives with Turbo Fins. So choose a partner and enjoy the ride.



[hobiecat.com](http://hobiecat.com)



## Lowrie Yacht Harbor INC.

*In central Marin, convenient to Delta & Golden Gate  
Family owned & operated since 1948*

- **\$6.50** per foot – Best Rates this side of the Bay
- 25' - 65' Berths Available
- Surge and Wind Protected – Out of the Fog
- Convenient Location – Warm and Sunny
- Whole Foods & Trader Joe's Nearby
- Office Space Available

**(415) 454-7595**

40 Pt. San Pedro Rd., San Rafael, CA 94901  
*New Harbor Office Hours: M-F 9:30-4:30*

## We've Got You Covered Power or Sail



Wavestopper hard tops  
Full service canvas & upholstery  
Dodgers, biminis  
Custom molded roof tops  
**(707) 812-8108**  
[baysidecanvas3@aol.com](mailto:baysidecanvas3@aol.com)

*Bayside  
Canvas*  
  
*serving the entire  
Bay Area*

## blonde california teen girl sets off epirbs in southern ocean

That pretty much sums up the headlines in the mainstream media in what, based on their coverage, has been the biggest sailing story in all of history. Abby Sunderland and her family wanted fame, and they got more of that than they could have dreamed of. But for the parents

in particular, it has come with a large dose of infamy. As for Jessica Watson, who actually accomplished the nonstop solo circumnavigation by the Southern Ocean that both girls had been attempting, one month later she was relegated to the back pages. Nonetheless, Australian sources report Watson has raked in nearly \$1 million, with much more in the offing. If 'million bucks' aren't the two words to prick the ears of stage parents the world over, and maybe even some junior sailors, none will. As a result, we don't think we've seen the last attempts on ill-advised age-based sailing records.

In the remote possibility that someone hasn't heard the basics of the Abby Sunderland tale, here's a quick summary:

- July 16, 2009 — 17-year-old Zac Sunderland of Thousand Oaks finishes a solo circumnavigation via a traditional route aboard the Islander 36 *Intrepid*. Prior to his team's flying

in a reported six times to make repairs at various places along the circumnavigation, Marianne Sunderland told *Latitude* that the initial budget had been \$285,000. The press was appreciative but not gushing over the adventure.

- July 15 — The day before Zac's homecoming, his 15-year-old sister Abby reveals that it's been her "lifelong dream" — or at least since she was 13 — to sail around the world. She wants to be the youngest person to do it, which means she'll have to do it via the Southern Ocean, an enormously more difficult achievement than her brother's trip, because then-15-year-old Aussie Jessica Watson is already planning to go for it aboard her S&S 34 *Ella's Pink Lady*. Sunderland's team must get a boat, prepare it, and have her take off ASAP. Her age is both her calling card and her greatest enemy.

- October 26 — The Open 40 *Wild Eyes* is purchased in Rhode Island. After the boat is acquired, Stephen Mann of San Diego, who sailed the proposed course a year before, says that Laurence Sunderland told him that \$400,000 has been spent upgrading the boat and that the project has brought in millions in sponsorship. There is no telling if Sunderland was being factual or just boasting, but the press adores this adventure, just as the press loves 16-year-old girls more than it does 16-year-old boys.

- January 23, 2010 — Claiming to have been a "lifetime sailor" — the details of which are no more freely available than is the recipe for Coca-Cola — Abby sets off from Marina del Rey. Before she leaves, one Southern California publication reportedly anoints her 'Sports-woman of the Year.'

- February 2 — Abby pulls into Cabo San Lucas, after just 10 days at sea, with electrical consumption issues and a number of other problems. Team Abby declares the leg to Cabo was actually a "shakedown sail," and that Abby will begin her attempt anew from there.

Behind the scenes, a battle brews between Team Abby and Magnetic Entertainment of Santa Monica, which on its website has announced they are making a documentary of Abby's attempt as well as developing a Sunderland Family reality show. A cameraman for Magnetic will later say the company pulled out because they felt neither Abby nor the boat was ready and the proposed trip was too dangerous. Laurence Sunderland later tells Larry King the man is a liar and Team Abby pulled out because the film team actually had plans to make a fea-

continued on outside column of next sightings page

## mexico's

Drug war violence is out of control all over Mexico, right? If you judged solely by the headlines that appear in American mainstream media these days, you could certainly get that impression. Due to the old newsmen's credo, "If it bleeds, it leads," almost all of the contemporary news we get about Mexico focuses on the very real gun battles between government troops and drug cartel operatives. But many of our neighbors to the south — including cruising sailors, shorebound expats, and business owners — complain that the American public isn't getting the whole story.

In fact, almost all of the recent violence is confined to three border towns

WWW.GIZARAARTS.COM



*It's our opinion that Abby Sunderland didn't fully understand what she was getting into — in regards to the Southern Ocean and the media storm that hit after her dismasting.*

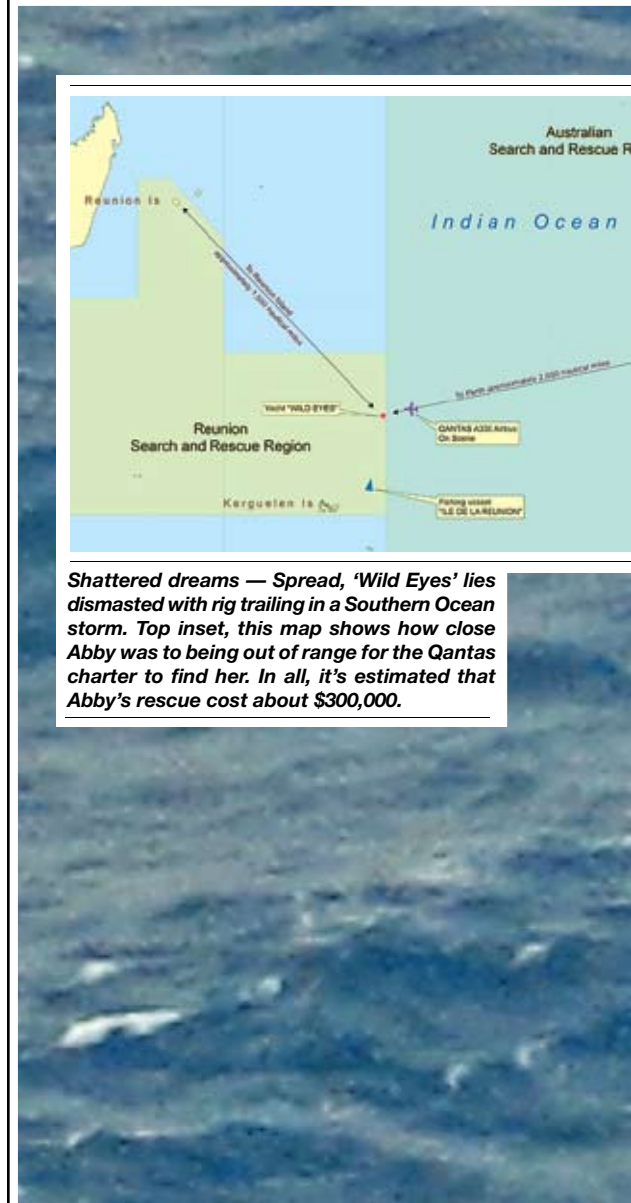

**Shattered dreams — Spread, 'Wild Eyes' lies dismasted with rig trailing in a Southern Ocean storm. Top inset, this map shows how close Abby was to being out of range for the Qantas charter to find her. In all, it's estimated that Abby's rescue cost about \$300,000.**



**bad rap**

— Tijuana, Nogales, and Juarez — which have traditionally been shipment points for massive quantities of illegal drugs headed for the U.S., plus Mexico City, where many kidnappings for ransom have occurred. Although you wouldn't know it from reading newspaper headlines or watching the evening news on TV, the rest of the country has been virtually unaffected. Within the cruising community, we haven't heard of a single incident involving visiting sailors or shoreside tourists.

Some in Mexico go so far as to theorize that the negative media blitz is a conspiracy aimed at trying to slow the flow

continued in middle column of next sightings page

**abby — cont'd**

ture about his daughter dying at sea. Marianne Sunderland tells KNX News that there never had been a contract between the Sunderlands and Magnetic — which is odd because for a long time Abby's website directed potential sponsors to "make checks payable to Magnetic Entertainment, Inc." It's difficult to know who, if anyone, is telling the truth, but we wouldn't buy a used car from any of them.

- March 31 — Abby rounds Cape Horn. Whether inspired by the desire for fame and fortune, the belief in God, or just raw determination, there is no denying that Abby Sunderland has courage.

- May 5 — Citing problems with autopilots, Abby pulls into Cape Town, thereby ending her chances of doing a nonstop solo circumnavigation and being the youngest person to sail around the world.

- May 21 — With her shot at the record gone, Abby nonetheless leaves Cape Town after repairs are completed — even though it means she'll be sailing across the Southern Ocean in winter, something even the world's greatest sailors don't do because of the extreme weather. Sailors

continued on outside column of next sightings page



# SIGHTINGS

## abby — cont'd

still following Abby are mostly stunned. On Abby's Wikipedia listing, the Sunderlands are said to be born-again Christians, and Laurence is quoted as saying that, as such, they don't always do things based on reason. Abby's sailing into the Southern Ocean in winter would seem to be a prime example. Meanwhile, critical or even questioning posts to Abby's website don't see the light of day. From the website's point of view, you're either completely for Abby or you don't exist.

- June 10 — Abby sets off two EPIRBs. The mainstream media and popular press wet their pants, because what's more gripping than the possibility that a blonde California teenage girl might be dying in the cold and lonely Southern Ocean? Conditions there hadn't been good at the time the EPIRBs were set off, but they hadn't been particularly bad either. It was just the Southern Ocean being the Southern Ocean.

- June 11 — A Qantas Airbus is chartered by the Australian gov-

continued on outside column of next sightings page

## mexico

of North American cash into Mexico. In a recent article on the website *Mexinvestnow.com*, author Charles Simpson cites the fact that Mexico is now the number one retirement destination in the world, with over two million Americans and Canadians currently owning property there. A conservative estimate of Baby Boomers who are expected to buy property 'south of the border' in the next 15 years, says Simpson, is more than six million. Add to this the phenomenal growth of so-called "medical tourism" to Mexico due to exorbitant pricing in the U.S. This is such a huge growth industry that medical ex-



PHOTOS LATITUDE / LADONNA

*Looking good! Clockwise from spread, 'Ho Beaux' barrels across South Bay like a freight train; the crew of 'Kat Den Rie' enjoy some June sun; 'Such is Life' and 'Y-Knot?' don't have a care in the world; a full boatload of fun on 'Imi Loa'; 'Ahava' daydreamin'.*

## — cont'd

penditures from foreigners are expected to add 5-7% to Mexico's GDP.

While such figures are eye-opening, we don't really buy into the conspiracy theories. But we do know that wherever we've traveled in Mexico in recent years — and we travel there often — we've always felt at least as safe as, if not safer than, we do at home. So to us, shunning the anchorages and resort towns of Mexico makes about as much sense as refusing to visit the Bay Area because of the murder rate in the toughest neighborhoods of Oakland.

— andy



## abby — cont'd

ernment to find Abby at a cost of about \$175,000 US. Some Aussie taxpayers suddenly begin to question the wisdom of letting teens, even their heroic Jessica Watson, sail solo around the world. Abby is found in good condition, but her boat is dismantled. Even weeks later, Team Abby, which runs a pretty opaque program, has provided no real details of the circumstances of the dismantling. Presumably they are saving it for the book, which Abby suddenly decides she'd like to write.

- June 12 — Abby is rescued from *Wild Eyes* — which for some unknown reason is not scuttled — and is taken aboard the French vessel *Ile de la Reunion*. The captain of the rescue boat falls in during the rescue, but is saved. For Abby, it is the beginning of several long and slow boat rides back toward civilization.

- June 13 — Abby's website encourages followers to contribute to a "Bring *Wild Eyes* Back" campaign because Abby apparently can't bear the thought of not seeing her boat again. There is enthusiastic response — before someone realizes that such a notion is not just romantic, it's also just plain silly, and the campaign is terminated.

- June 23 — As we write this, Abby still has not reached civilization.

The initial reaction in the mainstream and pop press was that it was

a daring and brilliant adventure. But then more people, including celebrity sailors Geraldo Rivera and Dr. Laura, began to savage the parenting decisions of the Sunderlands. After reports got out of the possible deal for a Sunderland Family reality series, and there was a greater understanding of the backstory, the tide started to go out.

As for people who have actually been on sailboats, the feeling had been much more negative from the beginning. We at *Latitude*, for example, had always been against both the Watson and Sunderland efforts. We wrote extensively about the Abby effort in the June 11 and 14 editions of *'Lectronic Latitude*, and received some of the greatest response to anything we've written. The response was overwhelmingly negative on the adventure. Understandably to us, Abby, as an inexperienced minor who can't be expected to know any better, came out relatively blameless. Nearly all the contempt and anger was reserved for parents Laurence and Marianne — who many people thought had appeared shockingly unemotional in television interviews when the fate of their daughter was still unknown.

In order to have as much space as possible to run reader responses, those who want to read the two *'Lectronic* pieces will have to do so online at [www.latitude38.com](http://www.latitude38.com). But to summarize our position in one very long sentence, we gave the Abby adventure a jaundiced eye because we saw it as a reckless stunt in pursuit of pop fame and fortune by someone too inexperienced and young to comprehend the risks, and with a team that had a 'get rich and famous or die trying' mentality, highlighted by taking on the Southern Ocean in the wrong season on a boat that wasn't any more ready than Abby was, while counting on others to risk their lives to save Abby's life at the first sign of trouble. Sort of a sailing version of *Jackass*, because it's hard to know which to be more impressed by, the Johnny Knoxville-like daredevilry or the Johnny Knoxville-like foolishness of the stunt. Nothing personal against Abby, but we think she was pimped, willingly or not, into being the *Jackass* of the Seas by two candidates for the Worst Parents of the Year. But that's just our opinion.

For reader opinions, see pages 100-103.

— richard



COURTESY AUSTRALIAN SEARCH & RESCUE

**The 'Ile de la Reunion' plucks Abby off 'Wild Eyes', but not before the French skipper fell in the water and had to be saved himself.**

# SIGHTINGS

## sailing teen needs a home

Despite what some might have you believe about 16-year-old girls' activities, there is middle ground between sailing nonstop, single-handed around the world and falling into the dark world of drugs. Take Viviane Farke, for example. This 16-year-old German student, who hopes to find a sailing family in the Bay Area to host her during a 10-month exchange program, is a sailing fanatic.

"My favorite hobby is definitely sailing," Viviane wrote in her application to her student exchange program. "I am crazy about it and I spend a lot of time at the Elfrather See, a lake in Krefeld. In the photo

you can see my friend Simon and me sailing a boat called a 420."

Viviane, who has a younger brother and sister, is an A/B+ student and plans to go into the sciences to become a doctor or researcher. Her other interests include playing guitar, dancing and soccer, but none apparently come close to sailing.

Cheryl Williams,

who works with Inter-Ed to place foreign students in California homes, contacted us in hopes of finding a suitable home for Viviane. "I normally place kids in the Fresno area but we don't have a lot of sailing here," she said. "Viviane sails twice a week so I really hope someone in the Bay Area who's involved in sailing will host her."

Suckers for sailing kids, we promptly posted Viviane's story in June 16's *'Lectronic Latitude*. "Great news! I had a family request to host Viviane," read Cheryl's email a few days later. "The bad news is that the deadline to enroll at Redwood High School, where she would attend, was June 15 and they wouldn't accept her. Not to say it's not difficult, but I must honor all schools' rules. I'll keep trying for Vivi, you know I will!"

Cheryl notes that while the program is 10 months, it's possible to split the commitment between two homes, though the ideal is to have Viviane stay in one home the entire time. All students are fluent in English and arrive with their own medical insurance and spending money — host families are asked to provide a roof over their heads and meals. "And it doesn't have to be a family with kids," Cheryl said. "Retirees and couples are welcome to apply as well." The application process seems relatively painless, as well as obvious — criminal background check, Megan's Law check, reference check and in-home interview — but Cheryl needs to find a host by July 30 or Viviane may have to suffer through a year of no sailing, and that would be a shame.

If you're interested in hosting Viviane, email Cheryl at [cheryl@inter-ed.org](mailto:cheryl@inter-ed.org) or call her at (559) 940-4713.

— ladonna

## grounding in monterey

The long Memorial Day weekend was surprisingly slow for Capt. Chelsea Wagner, owner of Pacific Salvage in Santa Cruz. That may not be great news for a tow boat operator, but it's good news for boaters. Unfortunately, one sailor wasn't so lucky. The owner of the Monterey-based Hunter 27 *Aeolus* was reportedly out for a daysail on Saturday when he noticed the 30 feet of water he had been sailing in off Del Monte Beach was shoaling rapidly.

"He was getting ready to tack away when it went from 30 feet to

continued on outside column of next sightings page

## kiwi chainsaw

Some cruisers are lucky, smart and/or frugal enough that they don't have to work. Whatever income they've arranged back home fills the kitty every month and they live within those means. The rest have to find periodic employment.

Some cruisers work within the yachtie community, doing mechanical work or sail repair for other cruisers, for example. Others work in the country they're in, if the rules allow it. We know folks who have taken courses and even gone into careers such as nursing and diesel mechanics specifically to use those skills when they go cruising.

And then there are the fringe jobs. It never ceases to amaze us how creative cruisers can be when it comes to generating income. We once met a Mexico-bound



COURTESY INTER-ED

Where could be better than the Bay for a foreign exchange student who sails? Let's find her a host home!

Yeehaw! The salvage crewman who rode through the surf aboard the grounded 'Aeolus' reported becoming airborne.



## massacre

Canadian couple right here in Sausalito who had a breeding pair of AKC-registered toy poodles aboard — along with 8 or 10 boisterous little balls of fur. They were planning to partially finance the trip by selling litters of puppies along the way. Would we be interested in a cute female for \$500? Uh, no thanks.

But surely the most unusual cruiser job we've heard of was held by Serge and Robin Testa, who circumnavigated from 1995-1997 aboard the 60-ft steel sloop *Encanto*, which Serge designed and built himself. It was in New Zealand where they found the oddest of odd jobs. There was a huge park with literally hundreds of palm trees, and all of them were dropping fronds and looking generally messy.

continued in middle column of next sightings page

## grounding — cont'd

4 feet in half a second," reports Wagner. Apparently the sailor had met a shoal area that built up over the winter — and isn't charted. "It runs a good 150 yards out from Del Monte Beach," Wagner said. If you sail in Monterey, consider yourself warned.

"We had to drag it farther up the beach and out of the surf to wait for our boat," Wagner noted. "She was lying on her port side, so before we started towing, we managed to get her on her starboard side for inspection. There were no holes but the gelcoat was worn through in a couple spots where she'd been lying on some rocks.

"We tried pulling her around by tying to a deck cleat but that snapped off, so we wrapped the tow line around her keel. Normally a boat in this situation isn't a good candidate for towing but, even though the rudder had already sheared off at the hull, the keel was fine and the boat wasn't taking on any water."

Wagner says the *Aeolus's* owner — who wasn't injured in the incident — didn't have insurance but that he intends to repair her. "Hunters seem to survive this kind of abuse better than other boats," she said. "It seems their fiberglass is more flexible than brittle."

— *ladonna*



**Capt. Chelsea Wagner and her crew ready 'Aeolus' for a rough tow out of the surf.**

# SIGHTINGS

## ***ocean watch* completes her circuit**

After 13 months of voyaging, the 64-ft steel cutter *Ocean Watch* returned to its Seattle homeport last month, thus becoming the first vessel ever to complete a lap around both North and South America. That remarkable accomplishment was bittersweet, however, as the specially equipped vessel's route through the fabled Northwest Passage was aided by the fact that Arctic ice is decreasing at a shocking rate — last summer, every boat that attempted the transit was successful for the first time ever.

All along the 28,000-mile route of the Around the Americas expedition, hard-wired instruments and visiting scientists collected a wide range of data which is being shared with several national and international research projects. But the principal aim of the ambitious circuit — which crossed latitudes between 74°N and 56°S — was to

continued on outside column of next sightings page

## **massacre**

Serge contacted the park folks and asked if they would like the trees trimmed. They agreed to pay him and Robin \$25 per tree to do the job.

The couple bought a small pickup, a chainsaw and a ladder. Early one morning, they started in. About 10 minutes into trimming the first tree, Serge was overrun by large, green velvet ants that bit the crap out of him. Turns out that they live in almost every tree. It also turns out that's why nobody wanted to trim the trees. However, by painful trial and error, Serge and Robin figured out that it took



TERRI WATSON

## — cont'd

the ants several minutes to mobilize. If you could get in to and out of the tree in under five minutes, you could avoid an attack. The couple honed their skills, eventually turning into a lean, mean trimming machine, and were able to trim up to 10 trees a day — bite-free. They were able to cruise for months on the money they earned from that one job.

Do you have an unusual way to make money while cruising — either one you've done or plan to do? Let us know about it at [editorial@latitude38.com](mailto:editorial@latitude38.com).

— jr

**'Ocean Watch' was greeted by the San Francisco fireboat when she sailed under the Gate on May 26. She stayed on the Bay for a week, giving tours and talks to packed houses, before sailing north to finish what she'd started.**



## ocean watch — cont'd

raise public awareness about the sorry state of our oceans' health, and inspire public action to make positive changes.

By all accounts those goals were met through countless tours and presentations at 46 port calls along the way in 13 countries, and via the extensive international press that the project attracted. We're hap-

py to report that in the aftermath of the cruise, Around the Americas' legacy will continue through its ongoing educational components, which include classroom lessons and activities focused on the vulnerability and interconnected nature of our "global oceans." Use of that term emphasizes the fact that despite the various names given to earth's oceans, they all comprise one massive body of water that is affected by influences all over the globe. (See [www.aroundtheamericas.org](http://www.aroundtheamericas.org) for educational resources, including free downloadable classroom materials.)

During *Ocean Watch's* Bay Area visit, we learned details about the project during an impressive presentation at Tiburon's Corinthian YC. But as thrilling as it was to relive the crew's sailing adventures through Captain Mark Schrader's narrative and expedition photographer David Thoreson's stunning images, it was also chilling to confront the negative realities of our oceans and fisheries. From top to bottom there's bad news: In the Arctic, the melting of pack ice is threatening the extinction of polar bears and other species, while off Southern Patagonia, the devastation of fisheries is threatening the traditional livelihoods of entire communities.

Still, scientists such as Dr. Michael Reynolds — who sailed with the crew during parts of the voyage — insist it's not too late to reverse current trends. What can we laymen do to help? According to Reynolds, many people making small changes in lifestyle and consumption of fossil fuels can make a tremendous difference. Check out the website for more on the project and its ongoing legacy through affiliated organizations, and be on the lookout for an upcoming book on the trip by the expedition's scribe, Herb McCormick.

— andy

**freda gets her whiskey plank**

One hundred and twenty-five years after she was first launched on the shores of Belvedere Cove, the 32-ft gaff sloop *Freda* marked a momentous occasion on June 5 when she received her shutter plank. The roughly eight-ft plank finished off the hull-planking phase of the decade-long restoration of the West Coast's oldest sailing yacht by the Arques School of Traditional Boatbuilding, the Spaulding Wooden Boat Center, the Master Mariners Benevolent Association, and local preservationists and donors.

About 100 people showed up to watch what's also known as the "whiskey plank" get a splash of deep-gold firewater before being fastened in place by graduates and students of the Arques School, which shares the Spaulding Center space. A short presentation started things off with a history of the yacht and a talk by Arques School Director Bob Darr, who commented that, "*Freda* not only has a soul, but a soul with good karma."

When she arrived at Spaulding's in '04, *Freda's* sheer had flattened out and the hull was heavily distorted. Her long and storied history on the Bay almost saw its final chapter written in May of that year, when she sank at her slip in the Lowrie Yacht Harbor in San Rafael.

Serendipitously, a few months later the Spaulding Center was estab-

continued on outside column of next sightings page



DAVID THORESON

**'Ocean Watch' completed her circumnavigation of the Americas on June 17.**

# SIGHTINGS

## *freda* — cont'd

lished to take over the space that had been Spaulding Boatworks until that point, and the Arques School was invited to share the space.

The owner who let *Freda* fall into such disrepair had been inexplicably reluctant to part with her, but a deal was finally reached between the owner, the Center and the School, and Lowrie's agreed to forgive *Freda's* back slip fees if she went to the Center for restoration. A \$12,000 donation from the MMBA allowed the School to buy the lumber for the Port Orford cedar planking — so it could be 'stick-ered', or air-dried — which got the project in motion. Subsequently, the locally-sourced pepperwood frame lumber was milled and *Freda's* lines were lofted and faired at full scale from the measurements picked up when she was hauled at Spaulding's.

Looking at the rebuilt hull with its shiny silicon bronze fasteners and planks embossed with the names of the donors who have contributed to her museum-quality restoration, you'd never know how close *Freda* came to dying an ignominious death. While she's not finished yet, the grand dame of the Bay is even closer to plying her home waters yet again.

After the fastening of the plank — donated by former America's Cup sailor and filmmaker Dick Enerson — guests were treated to barbecued oysters and Anchor Steam beer, the latter courtesy of that brewery's founder and Spaulding Center client and supporter Fritz Maytag, who also donated the ceremonial whiskey which the crowd got to share in. Music was provided by the Waterfront Pickers, which included Tom List, who originally nursed a near-dead *Freda* from San Rafael to Spaulding's. The message of the day was that the project still needs more funding, but as Darr said: "We'll get it somehow."

—rob

## sailstice blows away bay sailors

Whether they were on the Bay with reefs tucked in, or elsewhere around the world under full sail, sailors the world over hoisted their cloth on June 19 to celebrate the 10th annual Summer Sailstice. With a 13-hour head start over those of us on the West Coast, the likely winners of the 'first to sail' honors for this global celebration of sailing started their sunrise sail at longitude 120°E on Lake Diashan in Shanghai, China.



ALASTAIR SKINNER

**The first Summer Sailstice sail happened at sunrise on Lake Diashan China!**

Later in the day, the Bay tossed up traditional summer fare with sailors blown away by 25-35 knots of gusty Bay breezes that tested the crews of boats racing in both the OCSC Perpetual Trophy and in the YRA's Summer Sailstice race. Those seeking more clement conditions found shelter in Clipper Cove with its easy access to the Summer Sailstice festival ashore on Treasure Island.

One of the hallmark events of the Treasure Island festival is the annual boat building contest. This year it attracted five teams for a day-long boatbuilding competition sponsored by *WoodenBoat Magazine*, Berkeley Marine Center and MAS Epoxies. All five boats were launched at 5 p.m. and all floated — even with crew aboard! Everyone nervously headed out on a frothy Clipper Cove in breeze up to 30 knots for a race around a mark and back that ended with a photo finish. After the votes from all competitors were tallied, Berkeley Marine Center took the top honors, followed closely by Team Hutchinson Marine Services.

On the docks hundreds of sailboat rides, organized by Club Nautique and Tradewinds Sailing Center, were given to Bay residents who came to check out the sailing scene. They were treated to rides that rivaled a day at an amusement park, and their \$5 donations supported Treasure

continued on outside column of next sightings page

## 30 months for

A 53-year-old Salinas man was sentenced last month to 30 months in federal prison for calling in a false mayday in October of '08, according to the *San Francisco Chronicle*. Kurtis Thorsted, who was at his home at the time of the call, told authorities that he was in a kayak off Santa Cruz and was having trouble getting to shore.

But that incident wasn't the first time Thorsted had caused trouble for the Coast Guard; the court found he'd made 51 false maydays over a six month period, and that the calls cost the Coast Guard \$102,000 in search costs. Thorsted was sentenced



**Clockwise from above, whiskey to celebrate the shutter plank installation; what's missing here? Bob Darr watches as apprentice Alex Rockwood fastens the plank; a permanent list of donors; 'Freda' is as lovely as ever; Anton Hottner drives the last screw.**

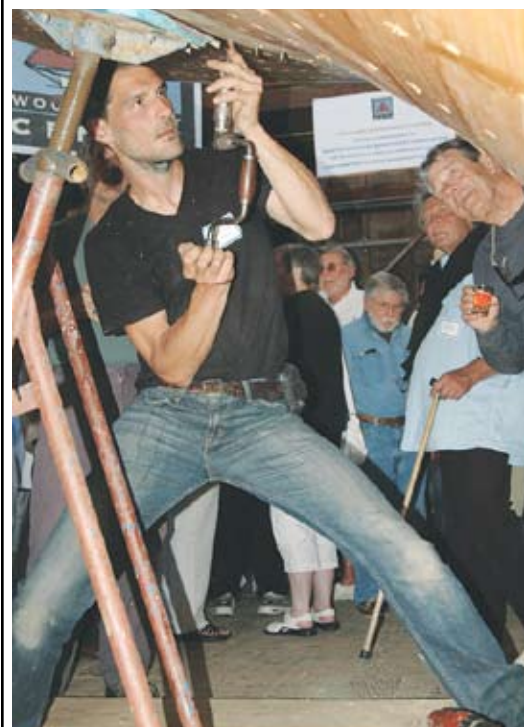



## fake maydays

to two and a half years in the pen and ordered to pay \$29,000 in restitution for the same offense back in '04. According to the *Chron* article, one of the earlier incidents delayed the rescue of two fishermen from their sinking boat when a Coast Guard helo was forced to refuel after searching for the non-existent Thorsted.

Thorsted's public defender reportedly asserts that her client had suffered a traumatic brain injury in '99 that left him permanently disabled. That's unfortunate, but someone has to figure out how to keep a radio out of this guy's hands.

— rob

## sailstice — cont'd

Island Sailing Center's community sailing programs. While ashore, sailors were entertained by Pacific Island dancers, some sea chanteys, and rock 'n roll by Bowjones featuring drummer Mike Tosse.

Check out the event's website at [www.summersailstice.com](http://www.summersailstice.com) to start planning next year's Summer Sailstice.

— john a.

## gaga for gold

A friend who works on commercial freighters once told this reporter that when she buys her cruising boat, she's going to paint it DayGlo orange. She was only half joking. "From the height of a commercial vessel," said Miri Skoriak, who works as First Mate on ships all over the world, "sailboats are typically seen on a background of water. They have so little return on the radar, and blend so well with the surroundings, that the slightest chop makes them disappear."

Visibility also becomes an issue when you get into trouble and

continued on outside column of next sightings page



PHOTOS LATITUDE / ROB

# SIGHTINGS

## gold — cont'd

request assistance. White sails, white hull, white mast — all are difficult, if not impossible to spot against a background of frothing seas. And while dark blue hulls are a feast for the eyes at the dock, they're essentially invisible on the water.

So, short of placing a bulk order at *DayGlo.com*, how can average sailors increase their visibility at sea? Inspired by the solution found by friend Jon Eisberg, I started researching options. While Jon's answer of painting the top third of his mast red would certainly be the easiest route — we already had the mast down for repainting — I was less than satisfied with the color choices available through Pettit and Interlux. Red would be more visible than white, certainly, but I wanted something that would scream, "DON'T RUN OVER ME!"

In my quest, I naturally browsed the aforementioned DayGlo site but found that fluorescent paints require fresh coats every year. Um, no. Then a lightbulb went off: the vinyl name on the transom still looks pretty good after a decade . . . what about fluorescent vinyl?

continued on outside column of next sightings page

## hopkins

'Yes We Can' was a rallying cry in the '08 presidential campaign, and one that was embraced by voters in June 8's Lake County primary elections. Incumbent District Attorney Jon E. Hopkins — the man who decided to prosecute sailor Bismarck Dinius instead of Deputy Sheriff Russell Perdock in the '06 boating death of Lynn Thornton — was soundly ousted from a spot on November's general election ballot by Don Anderson and Doug Rhoades. While the numbers seem surprisingly close — Anderson received 37.8% of the vote, Rhoades 32% and Hopkins 30.1% — the thing to keep in mind is that nearly 70% of the ballot-casters voted against

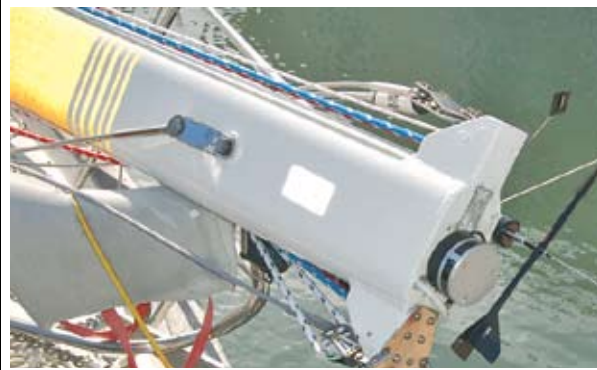

*Reflective personality — Clockwise from below, 3M Scotchlite 680, seen here glowing in the sun, is much easier to handle when cut into smaller pieces; an epoxy scraper works perfectly to smooth out wrinkles and bubbles; we used thin strips to 'finish' the vinyl job and added SOLAS-approved white reflective stickers at the top of the mast; at night, our mast really shines; Spaulding Center boatyard manager Michael Wiener was really impressed with our handiwork. "Your mast is beautiful," he said. We think so too!*



**is out**

Hopkins.

Similar numbers were seen in the race for sheriff, but with different results. Deputy Francisco Rivero took the top slot with 38.5% of the vote, but the second spot was filled by incumbent Sheriff Rod Mitchell — who some think steered the '06 investigation away from Perdock, his then-number two — with 34.5%. The remaining 27% went to Jack Baxter. Again, over 65% of the voters went against Mitchell, so it will be interesting to see who Baxter's supporters follow in November. We don't need to tell you what we hope for.

As for Bismarck Dinius, the man whose  
continued in middle column of next sightings page

**gold — cont'd**

Same problem — the fluorescence fades quickly.

Certain that the solution was near, I emailed 3M for product suggestions. They responded that their 7-mil retroreflective film (Scotchlite Series 680) would meet our needs, but they couldn't sell it to us. Denco Sales in Concord (reach them at (925) 822-0000) doesn't normally sell to the public but since our application was so unique, they agreed. At nearly \$15.60/yard, we were grateful that we could buy only what we needed — we figured six yards would do the trick.

Heeding Miri's advice that red, yellow and orange are the most visible colors against an ocean, we chose gold (680-64), and we couldn't be more thrilled. Not as garish as yellow, but with a typical retroreflection coefficient of 70 (white rates 100), our mast is pleasing to the eye yet, when illuminated, lights up like the encore at a Lady GaGa concert.

The magic of Scotchlite vinyl, which is guaranteed for seven years but should last much longer, comes from jillions of tiny glass beads covering a reflective metallic surface. The beads capture light from many angles and direct it to a focused line of sight, making the reflection appear brighter than it should. So if a helicopter is flashing a searchlight from above, and the beam crosses our mast, we'll be hard to miss. An added bonus is that we'll have no trouble finding our boat in a crowded anchorage.

Application of vinyl can be tricky. If you go this route, do yourself a favor and divide the vinyl into smaller sections. Tussling with a long strip of adhesive vinyl while trying to smooth out creases is an exercise in frustration. This vinyl is fairly forgiving during placement, but once pressure is applied, it's stuck for good, so go slowly, smoothing with a scraper as you work.

This is, of course, just our low-tech choice for making *Silent Sun* more visible on the water. If you've found a similarly low-tech, low-cost solution, we'd love to hear about it. Email [ladonna@latitude38.com](mailto:ladonna@latitude38.com) with the details and photos.

— *ladonna*

**pensioners in need**

We've always been fond of older cruisers who try to live life to the fullest in their later years, so when David Cherry of the U.K.-based F/P 39 cat *Puddytat* in the Sea of Cortez asked us to run the following plea, how could we refuse? It was written by Sylvia Heasman, the daughter of the couple in the piece.

"On May 21, not far from Tonga, a *pan pan* was broadcast. It was put out by my parents, Bob and Dawn Heasman, a couple of 78-year-old adventurers whose F/P Tobago 35 catamaran *Kudana* had been dismasted. Fortunately, nobody was hurt. But I think theirs is an interesting story, so I want to share it with *Latitude* readers.

"Bob and Dawn were both born in Rhodesia, now known as Zimbabwe. They grew up in the same area, met in school, and in due course were married. Every home they have lived in — as well as their boat — has been named *Kudana*, which means 'two together' in Shona, an African language.

"With the introduction of a black government in Zimbabwe in '80, Bob and Dawn were determined to give the new order a chance. But in '83, after the government refused Bob's annual 'foreign currency allowance' needed to spend his own money to import metal tubing for his manufacturing business, the couple began to worry. Bob tried to use locally produced tubing, but it split at the seams and rusted inside, making it useless. One day an African man came off the street to see him. Although the man didn't have a job, he'd been allocated a foreign currency allowance. He had a proposition for Bob — in return for the use of the man's foreign currency allocation, Bob should give him half his business. Bob was both furious and sick at heart.

"In '84, Bob and Dawn moved to South Africa. The only things they

continued on outside column of next sightings page

## pensioners — cont'd

were allowed to take were their car, a caravan, and \$700 U.S. They'd sold most of their possessions, but their money had been frozen by the government. As a result, they were only allowed to leave Zimbabwe with what's known as a 'holiday allocation' of \$700 U.S.

"Within a year of leaving Zimbabwe, Bob was told that he was terminally ill with non-Hodgkins lymphoma. At age 49, he was advised to get his affairs in order, as he only had three months to live. He lost his job, but the company organized a small pension for him. Bob

decided to become a guinea pig by submitting himself to experimental drugs to fight his cancer. Three months later he was still alive. Six months later he told the doctors that he would rather die than go through another round of chemo. But when they gave him a final check-up to record the results, they discovered he no longer had a trace of cancer — except in the scar tissue. Bob was euphoric, and before long had started another business.

"In '05, when things in South Africa looked as though they might become a carbon copy of what happened in Zimbabwe, Bob decided to retire. But he and Dawn began to worry again

about their future. The last thing they wanted was to once again lose everything they had worked so hard for because of political unrest and a badly managed government.

"One day Bob turned to Dawn and said, 'Let's sail around the world.' Dawn, a strong and resilient woman full of optimism and cheer, had been Bob's leaning post during tough times. She had taken each day and conquered it, wondering if her sweetheart would live to see another sunrise. Her response to her husband's suggestion was, 'OK, what do I need to do?' She was 73 at the time!

"In '06, my parents sold everything, right down to their last teaspoon, to scrape together the money to buy a cruising boat. They found an ocean-going catamaran in the Caribbean, an F/P Tobago 35, that looked just right for them. It had been standing on the hard for a long time and the owner wanted a quick sale. It was checked out by a friend and pronounced good, so they bought her. But in the two months it took to complete the purchase, the rand — South Africa's currency — had taken a beating, so they lost even more of their savings. Somehow they managed to scrape together enough to complete the purchase.

"Bob and Dawn were both excited about starting a new life on the sea, but Dawn was apprehensive, too. After all, they were both in their 70s, and she'd never sailed before. Bob, who had sailed and raced dinghies when he was young, felt more at home aboard *Kudana*. The couple did, however, find a captain to show them the ropes for the first three months until they gained confidence.

"After sailing in the Caribbean, the couple sailed 1,200 miles to the Panama Canal, then embarked on a long but successful crossing of the Pacific. It was just the two of them, a couple of courageous old-timers setting out to find a new life for themselves.

"At age 75, the two applied for residency in New Zealand, but it takes two years to process such an application, and visitors are only allowed to stay in the country for six months each year. In other words, my parents had to leave for the interim period. New Zealand isn't close to any other country, so after making many expensive upgrades to their floating home, they set sail for Tonga.

"On the morning of May 18, with the wind blowing 18 knots and the boat sailing at six to seven knots with reefs in the main and headsail, the mast, new mainsail, boom and rigging came tumbling down. The forestay had failed. The couple made a few attempts at salvaging some of the gear, but found it to be impossible in the six-ft seas 40 miles off Ha'afeva, Tonga. Using a hacksaw, they cut it all away.

continued on outside column of next sightings page

## hopkins

life was turned upside down by Hopkins's ill-fated prosecution, he's still just barely holding his head above water. Let go from his previous job more than a year ago because of the time he was forced to spend on his case, Bismarck is still unemployed. He long ago liquidated all of his assets to pay his legal bills but still owes upward of \$35,000. (You can donate to his defense fund through Paypal by sending money to [bismarckdinius@comcast.net](mailto:bismarckdinius@comcast.net). If you'd prefer to send a check, email [ladonna@latitude38.com](mailto:ladonna@latitude38.com) for instructions.)

The good news is that Bismarck just



SYLVIA HEASMAN

Bob and Dawn Heasman.

**Normally a 67.5-mile run up to Stockton from the Bay, this year's Delta Ditch Run was dubbed the Delta Ditch Beat. Most boats were able to fly some color near the finish line at Stockton Sailing Club. Read all about it starting on page 104.**



**— cont'd**

passed the licensing exam to become an insurance agent — now he just needs to find a job in or around the Sacramento area. And though he had to sell his own boat, he hasn't stopped sailing. "We won the Catalina 22 Region 10 Championships in the Go for the Gold Regatta on Scotts Flat Lake June 5-6 on Don Hare's *NoCatHare*," he said. All of this, along with Perdock's having been fired in April and Hopkins's being out of a job himself, has Bismarck feeling upbeat: "Two down, one to go!"

— *ladonna*

**pensioners — cont'd**

"Our sailing dreams are in disarray,' the couple now say. 'We're not sure how we can finance a new rig and sails after our expensive refit last winter, which we thought would be the last big expense for three to four years. So far the cost of a new mast in New Zealand is prohibitively expensive — about \$36,000 Kiwi — so we've been looking at other alternatives. Maybe a secondhand rig and secondhand sails.'"

Thus ends the story. We know there are lots of sad stories in the world, and in the world of sailing, particularly these days. But on the chance that anyone has been touched by the Heasmans' story, any suggestions, and even contributions, would be greatly appreciated. And Cherry assures us this is not a scam. If anybody wants to send money, it can be done by going to the Heasmans' blog at [www.sailblogs.com/member/kudana](http://www.sailblogs.com/member/kudana) and following the PayPal instructions.

— *richard*



CINDY CARPENTER

---

# '10 MASTER MARINERS



---

## — CHAMPAGNE SAILING



It's not very often that we get "Champagne sailing" on the Bay. Usually, it's either breeze-on and a bit chilly, or warm and windless. But the 56 woodies and classics that showed up May 29 for the Master Mariners' Benevolent Association's annual regatta got exactly that. Sailing on courses that ranged from 12.8 to 17 miles depending on the division, the fleet had a day to remember — it started off sunny and warm with enough breeze that every boat could fly all the canvas she had aboard. It stayed that way all day and through the night for the race's famous party at Encinal YC.

*From left — Ocean 1 winner 'Kate II' leads Call of the Sea's 'Seaward' off the starting line, while Jeff McNish's 'Valiant' tries to keep a clear lane at the the start of the '10 Master Mariners Regatta. Inset from left — 'Polaris' looking good; 'Sunda' flies a spinnaker, a rarity at the Master Mariners.*

The Sausalito YC ran the race as is customary, and the MMBA's lick-your-finger-and-raise-it-in-the-air rating system got high marks for accuracy from those we talked to, with the time deltas bearing that out; five of the 13 divisions were settled by a matter of seconds, and all but a couple by a few minutes.

In its modern era, which began in 1965, the event has drawn some of the West Coast's most gorgeous wooden boats, but perhaps most importantly the

boats you see here aren't museum pieces, they're actively sailed boats. Some are liveaboards, some are daysailed. Some introduce hundreds of kids to the joys of sailing every year. They're all living, breathing legends, many of whom call the Bay home, and we're better off for their presence and for the community of sailors who preserve and sail them.

— **latitude**/rg

ALL PHOTOS LATITUDE/ANDY

# '10 MASTER MARINERS

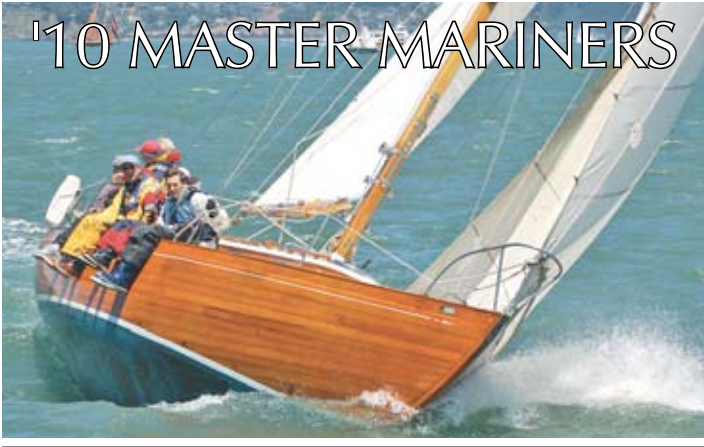

Clockwise from top left — Jack Coulter's Farallon Clipper 'Echo' gnashes upwind; it couldn't have been a sweeter day to ride the rail; Mary Moseley's 'Stardust' flying her colors; Terry & Patti Klaus' 'Brigadoon' rolls toward the finish line off Treasure Island; James Joseph's Bird 'Skylark' feathers upwind; Roger Emerick's 'Kate II' leads 'Seaward' off the line; if 'Scorpio' was racing she wasn't official, but she looks right at home just the same; according to the official results 'Aldebaran' must have also been in the unofficial tag-along division, but it didn't stop her from looking seriously fast; Gaff 1 winner 'Brigadoon' chases down Hans List's Gaff 2-winning 'Sequestor' on the reach to the finish off T.I.; Janice and Bill Belmont's 'Credit' powers away from the starting line off the Marina Green.





— CHAMPAGNE SAILING



# '10 MASTER MARINERS

## 2010 MASTER MARINERS RESULTS

### BIG SCHOONERS

*Seaward* Call of the Sea  
*Alma* Jason Rucker  
*Gas Light* Billy Martinelli

### BEARS

*Kodiak* Peter L. Miller  
*Chance* Anselm Wettersen  
*Huck Finn* Margie Siegal

### BIRD

*Widgeon* David Cobb  
*Robin* Cissy Kirane  
*Curlew* Pierre Josephs

### GAFF 1

*Brigadoon* Terry & Patti Klaus  
*Yankee* The Yankee LLC  
*Aida* Patty & Skip Henderson

### GAFF 2

*Sequestor* Hans List  
*Taihoa* Jody Boyle  
*Briar Rose* John T. Ough

### GAFF 3

*Stardust* Mary Moseley  
*Andrew Mulligan* Stephen Canright

### L-36

*Papoose* Allen Edwards  
*Leda II* David James  
*Olé* J. Hamilton & C. Leonard

### MARCONI 1

*Elizabeth Muir* Peter Haywood/Ivan Poutiatine  
*Pegasus* Peter Hayes  
*Gold Star* Jim Cullen

### MARCONI 2

*Nautigal* C. Jeff & Karen Stokes  
*Sunda* Robert & Colleen Rogers  
*Stroma of Mey* Dee Dee Lozier

### MARCONI 3

*Viking* SF Sea Scouts  
*Adagio* David Howell  
*Little Packet* Dick & Barbara Wrenn

### MARCONI 4

*Morning Star* Barbara Ohler  
*Kaeresta* Roger & Carmen Rapp  
*Folksong* Terri Watson/Kimi Harrison

### OCEAN 2

*Credit* Janice & Bill Belmont  
*Echo* Jack Coulter

### OCEAN 1

*Kate II* Roger Emerick  
*Valiant* Jeff McNish



Bay Area-product 'Elizabeth Muir' looking good with a kite up as she rolls across the Circle.



**MARINERS**  
 GENERAL INSURANCE GROUP

## INSURING YACHTS FOR OVER 50 YEARS

Providing Cruisers and Racers All Over the World  
 with Prompt, Reliable Service since 1959

Contact Us for a Quote

Exclusive  
**MARINERS Odyssey®** Program  
 Mexico  
 South America  
 South Pacific  
 Caribbean  
 Mediterranean

### Racing Sailboat Program

TransPac  
 Pacific Cup  
 PV / Cabo Races  
 Caribbean Regattas

[www.marinersins.com](http://www.marinersins.com)

### QUALITY COVERAGE AVAILABLE IN MEXICO

Mariners Insurance Mexico offers insurance programs  
 for health, homes, autos, motorcycles and yachts in Mexico.

[www.marinersmexico.com](http://www.marinersmexico.com)

Corporate Office: 206 Riverside Ave., Suite A, Newport Beach, CA 92663 / Ins. Lic. #0D36887

Seattle  
 800-823-2798

N. California  
 boomeins@aol.com  
 800-853-6504

L.A./Orange Co.  
 800-992-4443

San Diego  
 800-639-0002



Puerto Vallarta  
 52-322-297-6440

East Coast  
 Bradenton, FL  
 800-914-9928





# MODERN SAILING SCHOOL & CLUB

Sausalito, CA [www.ModernSailing.com](http://www.ModernSailing.com) (415) 331 - 8250

Get your Coast Guard Captain's License.

Sept. 13 - 25  
2 week intensive

**OUPV LICENSE**  
**\$995**

**100 TON LICENSE**  
**\$1195**

Our GUARANTEED, U.S. Coast Guard Approved course will prepare you for all elements of the exam, guide you through the application process, and conclude with on-site testing.



## Advanced Sailing Courses along the California Coast

### Heavy Weather Offshore Course

**August 2 - 8**

*Coastal Navigation (ASA 105)  
Advanced Coastal Cruising (ASA 106)*

Because of dynamic conditions that present challenges even to experienced sailors, the California Coast provides the perfect setting for training students at the advanced level. Join experienced instructor Stan Lander for a 7 day trip to Monterey and back. Space is limited to 4 students. Enroll today!

**Also Available: 4 Day ACC (ASA 106), Sept. 3 - 6**



with  
**John Connolly**

### Advanced Certifications in Spain & Morocco

**LEG 1: October 30 - November 8, 2010** (Mallorca - Gibraltar, via Spanish Gold Coast)

**LEG 2: November 11 - 24, 2010** (Gibraltar - Canary Islands, via Moroccan Coast)

**Leg 1** \$2475 / berth  
\$4450 / cabin

**Leg 2** \$2900 / berth  
\$5220 / cabin



**ASA OUTSTANDING SCHOOL OF THE YEAR**

## RICHARDSON BAY MARINA

formerly Kappas Marina

MODERN FACILITIES IN A WELL-PROTECTED HARBOR

**Concrete Dock System**

**Well Maintained Facilities**

**Beautiful Surroundings**

- DEEP WATER BERTHS: BASIN AND CHANNEL DREDGED
- CARD KEY SECURITY SYSTEM
- DOCK CARTS
- PUMP OUT STATION
- AMPLE PARKING
- CLEAN SHOWER AND TOILET FACILITIES
- WITHIN WALKING DISTANCE: MARKET/DELI, LAUNDROMAT, RESTAURANT
- AT EACH BERTH: LARGE STORAGE BOX, METERED ELECTRICITY, PHONE HOOKUPS, WATER

**BERTH YOUR BOAT IN SAUSALITO**

415 332-5510 [www.richardsonbaymarina.com](http://www.richardsonbaymarina.com)  
100 Gate Six Road, Sausalito • Fax 415 332-5812

**SAUSALITO**

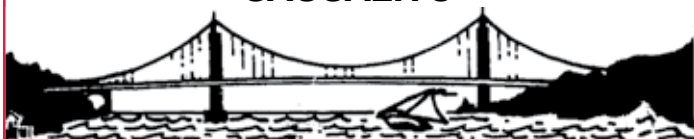

## LIST MARINE INC.

- Full service engine shop
- We service all makes
- Dockside facilities
- Mobile service trucks

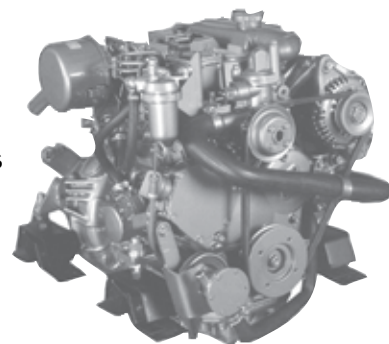

**YANMAR**  
marine

P.O. BOX 2008 / 69 LIBERTY SHIP WAY • SAUSALITO, CA 94966  
Adjacent to Schoonmaker Pt. Marina

**415•332•5478**

**[www.listmarine.com](http://www.listmarine.com)**

# WIND, FIRE & RAIN —

According to Polynesian legend, when strong winds blow across the face of Moorea's sacred Mount Rotui, they announce the arrival of special guests. We don't know how the ancients defined "special," but if their concept included sailors who've come from afar to soak in the magic of these fabled isles, then the arrival of the 2010 Tahiti-Moorea Sailing Rendezvous fits the folklore perfectly.



**Keith and Shirley were eager to visit Tahiti, but never expected a welcome like this.**

Driven by the strongest winds in the event's 5-year history, the fleet flew across the channel from Tahiti's Papeete Harbor to Moorea's Opunohu Bay in record time. In fact, with beam winds gusting to 30 knots, every boat seemed to be sailing faster than its theoretical hull speed, and at least a dozen skippers reported that they'd hit their fastest speeds ever.

"We came in dead last in the yacht race, and last in the foot race," said Keith Bowen of the South Africa-based Lavranos 40 *The Road*. "But we still had a fabulous time." And no wonder. We

can't think of another cruising destination in the world where cruisers get such a generous welcome. This year's fleet of salty passage-makers was showered with kindness and treated as VIPs, from the moment they arrived at the Rendezvous Village on Papeete's downtown quay June 18, to the final dance show two

*The whole fleet broke out of the island's wind shadow and shifted into overdrive as winds increased into the mid-20s.*

days later beneath the coconut palms of Moorea's idyllic Mareto Beach.

Why all the fuss? First and foremost, French Polynesians — who seem to be an innately friendly people — love to expose visitors to their highly-revered cultural traditions in the realms of music, dance, sport and cuisine. Secondly, the local government has come to realize that visiting sailors are a small but important part of their overall tourism picture. After all, no other niche group spends money throughout the islands of this French territory's vast archipelagos.

With the worldwide recession still plaguing tourism all over the world, it's a refreshing irony that more cruisers seem to be arriving in Tahiti than ever before. *Latitude's* Pacific Puddle Jump Rally alone had 217 entrants, and the 65-boat rendezvous set a record as French

***Blasting to the finish. It's hard to imagine a more idyllic anchorage than the lagoon off Mareto Beach, beneath sacred Mount Rotui.***

Polynesia's largest sailing event ever!

The brain-child of longtime Tahiti resident Stephanie Betz, the rendezvous is supported by the Port of Papeete, Tahiti Tourisme and several other partners, including *Latitude 38*.

For 15 years we've been reporting on the annual cruiser migration from the West Coast of the Americas to French Polynesia — and hosting bon voyage parties on the front end. But it wasn't until the rendezvous concept took shape that arriving cruisers had a forum in which to celebrate their successful 3,000-mile crossings from the mainland.

Each year a disparate fleet of Puddle Jumpers sets sail from many points along the West Coast. The largest numbers jump off from Puerto Vallarta and Panama. While en route to the islands, they share anecdotes and weather info via high frequency radio nets, but it isn't



# TAHITI-MOOREA SAILING RENDEZVOUS



troupe of six versatile musicians who set the mood with their ukuleles, guitars and hand-made wooden drums.

**W**inds were deceptively light outside the harbor mouth Saturday morning as the fleet jockeyed for position at the start of the 18-mile race/rally to Moorea. Within minutes, the 40-ft X Yacht *Exabyte*, with the Danish Ernst family aboard, walked away from the fleet as if they were motorsailing, while many boats wallowed in light, fluky air. "We came so close to stalling completely," said Jim Milski of the Schionning 48 cat *Sea Level*, "that we almost started slipping backwards."

A couple of miles out, however, the whole fleet broke out of the island's wind shadow and shifted into overdrive as winds increased into the mid-20s, just aft of the beam. All along the course, the smaller boats were nearly broaching as the prevailing swells hit them beam-on. But as many skippers confided later, no one wanted to be the first to reef.

Somewhere in mid-channel, Frank and Karen Taylor's St. Francis 50 cat *Tahina* broke ahead of the well-sailed X Yacht and set a daunting pace for the other multihulls. But neither *Sea Level* nor Steve May's Corsair 41 cat *Endless Summer* was about to give up the fight.

As the three fast cats arrived along the coast of Moorea, winds began gusting to 30. At one point *Endless Summer* got going so fast — 17+ knots — that her rapidly spinning prop "bump started" her engine.

"We were going 10 to 14 knots," Steve recalls, "when *Sea Level* passed us as if

**The 'Bubble's crew serves as evidence that not all cruisers are old and gray. The fleet encompassed all ages.**

***In the Tahitian isles, traditional music and dance are deeply revered customs that are passed from generation to generation.***

until the rendezvous that many of them finally meet face to face.

**S**everal days before this year's event, fleet members converged on the docks of the downtown quay — which are gated and guarded 24/7 — filling them to capacity. Impressed, Port of Papeete General Manager Patrick Bordet announced that he'll add more docks next year, and he even has plans to build a sailor's bath house with a laundry and wi-fi.

At the Village Friday afternoon, entrants from more than a dozen countries received their welcome packets — complete with two free T-shirts and other goodies — and

were reminded that they definitely did not want to miss the reception that evening, hosted by the mayor's office.

At 6 p.m. sweet Tahitian melodies drifted on the breeze through the harbor, as a Tahitian band led fleet members along the quay and a few blocks inland to Papeete's classic, colonial-style town hall (*Mairie de Papeete*). Inside, they were adorned with fragrant flower leis, welcomed by a variety of dignitaries, offered Tahiti's signature Hinano beer, and white wine produced on a Tuamotu atoll, and offered an elegant spread of hors d'oeuvres.

"What did we do to deserve all this?" asked one gray-bearded cruiser, obviously blown away by the elaborate effort. The highlight, however, was an eye-popping dance show accompanied by a

ALL PHOTOS LATITUDE / ANDY



# WIND, FIRE & RAIN —

we were standing still!" From the first point of land to the finish line at the entrance channel to Opunohu, she and *Tahina* were in an all-out drag race, with *Sea Level*, the eventual victor, clocking a record speed of 19.3 knots!

**W**ith the fleet tucked in behind the outer bay's long reef, there was plenty

of time for the adrenaline to dissipate before Moorean drummers summoned everyone ashore for a splendid kids' dance show and Tahitian barbecue that lasted well into the evening. It was there, while watching a series of short educational videos, that we learned Opunohu's entrance, named *Passe Terau*, means

the place where the four winds meet. It certainly seemed well-named, as strong winds whistled through the anchorage most of the night.

It was a different story at dawn, however. As predicted, the passing weather system gave way to heavy overcast and occasional downpours. But few were



# TAHITI-MOOREA SAILING RENDEZVOUS

ALL PHOTOS LATITUDE / ANDY EXCEPT AS NOTED

dissuaded from coming ashore for the variety of traditional Polynesian sports that had been scheduled, which were not to be missed — especially the six-person

outrigger canoe races.

With accomplished local racers seated in the bow and stern, teams of four sailors climbed into the four middle seats of

each sleek canoe, and paddled as though their lives depended on it during a series of heats, with four or five canoes in a line. Even for those who inexplicably capsized — in one case, prior to the start — it was a heart-pounding experience that will not soon be forgotten.

While cruisers of all ages learned the proper technique for husking and harvesting the meat of coconuts, other

**Top row, left to right: The 'Furthur' crew psychs up for the canoe race; extracting coconut meat the island way; sweet Tahitian melodies; an eco-friendly 'chapeau'; tug-of-war tussle. Middle: "Hit the coconut, not my hand!"; mid-channel knockdown; shakin' it like a Tahitian; canoe race conquerers. Bottom: Deceptively light winds at the start; learning to weave; bringing home the bananas.**



JULIE TURPIN



# TAHITI-MOOREA SAILING RENDEZVOUS

games were played whose roots go back centuries. Tug-of-war was a big hit, as was the fruit carrier's race, where runners must circle a short course carrying a staff weighted with stalks of bananas at each end. As many contestants found out, it's a lot harder than it looks, especially when it's raining.

More than a dozen classical Polynesian dishes were sampled that afternoon by those who opted to expand their culinary horizons with a traditional *Maa* lunch — eaten without utensils, as Tahitian forefathers did. The list of menu items included roast pork, taro, *poi*, pumpkin, a mixture of chicken and spinach, roasted breadfruit, sweet pineapple and delicious *poisson cru* — fresh fish marinated in coconut milk.

At the awards ceremony, prizes included hand-carved hardwood trophies, and every boat took home a polished mother-of-pearl shell, engraved with the rendezvous's distinctive logo. Afterward, a final music and dance performance dazzled the crowd yet again. And as always, the lovely Tahitian girls and buff, tattooed men sought out dance partners



**Don't even think about trying this at home. The fire-dancers' stunning performance gave extra sparkle to the final dance show.**

from the fleet. It's a rare cruiser who can shake their hips and shuffle their feet like an islander. But it was all in good fun, and they all left the dance floor smiling ear to ear.

The capper was a trio of fire dancers who stunned the crowd with their dangerous antics — twirling flaming batons in unison, licking the flames with their tongues and more. Although genuinely impressive, that's one sport we're sure none of the sailors in attendance would dare to imitate.

**B**ased on the effusive compliments from many participants, it's probably safe to say this year's Tahiti-Moorea Sailing Rendezvous was a high point of the season for all who attended. And with any luck, it will continue for many years to come. As the name implies, it established not only a gathering point for westbound passage-makers, but served as a window on Polynesian cultural traditions that many solitary cruisers might never have experienced otherwise. And it was a boatload of fun!

— *latitude/andy*

*Readers — By the end of the summer info about the 2011 event should be posted at [www.pacificpuddlejump.com](http://www.pacificpuddlejump.com).*

## Your Boatyard in the Heart of Paradise



*Large, fenced, secure dry storage area*

**Tahiti Customs policy has changed!**  
Foreign Flag vessels can stay on dry storage in our yard for up to 12 months out of 24.



A Subsidiary of  
The Moorings Yacht Charter, Ltd.

### Our Services |

#### HAULOUT

- Marine Travelift 25 tons
- Marine railway 120 tons
- Storage in adjustable steel cradles
- Fenced Yard

#### PAINTING

- Topsides, hull, bottom, varnish
- Brush, roller, spray

#### MECHANICAL WORK

- Inboard, outboard, diesel, gas
- All brands

#### REPAIRS

- Electrical repairs
- Refrigeration installation & repair
- Fiberglass & woodwork
- Welding, steel, stainless, aluminum

#### SAIL LOFT

- Sail repairs, biminis, dodgers, covers

#### STORE

- International, Pettit, Epiglass, Devoc
- Spares
- Fill U.S. gas cylinders

#### DO-IT-YOURSELFERS WELCOME!

*BoatUS Cooperating Marina*



*Professional boatyard in the heart of Paradise*

*Raiatea Carenage will make sure  
paradise is everything you expected.  
Call, write, or sail in . . . we're here to serve you.*

**B.P. 1111 Uturoa Raiatea 98 735 Polynésie Française**

**Tel: (689) 600-545 ~ Fax: (689) 600-546 ~ VHF 68**

**Web site: <http://www.raiatea.com/carenage> ~ email: [raiateacarenage@mail.pf](mailto:raiateacarenage@mail.pf)**



# BAJA HA-HA XVII

OVER 100 BOATS SIGNED  
UP SO FAR!

BROUGHT TO YOU BY  
THESE OFFICIAL SPONSORS

Turn the page for more →

**Yachtfinders/Windseakers**  
in the heart of  
San Diego's boating community  
Specialists in cruising sailboat brokerage for 28 years  
info@yachtfinders.biz • www.yachtfinders.biz  
**(619) 224-2349 • (866) 341-6189** toll-free  
Fax (619) 224-4692

[WWW.BAJA-HAHA.COM](http://WWW.BAJA-HAHA.COM)

The Rally Committee encourages  
you to patronize the advertisers  
who make this event possible –  
and take advantage of their  
Baja Ha-Ha Specials!

**OPEQUIMAR**  
MARINE CENTER CENTRO MARINO

A Full Service Boat Yard in Puerto Vallarta  
88 ton Travelift • Parts • Service • Repairs  
011-52 (322) 221-1800 [www.opequimar.com](http://www.opequimar.com)  
info@opequimar.com

Your  
Yacht Club  
South of the  
Border



Home  
of the  
Banderas Bay  
Regatta

Vallarta Yacht Club

<http://vallartayachtclub.org>  
<http://banderasbayregatta.com>

Everything you need from a full service yacht club.

## ARE YOU READY TO HA-HA?

With less than three months remaining before the entry deadline, more than 100 boats have signed up for this year's rally, and more are added daily. If you're on the fence about joining this year's southbound migration, we'll remind you that your "To Do List" will never be complete, so don't fall prey to procrastination. As thousands of rally vets would tell you, at some point you've just got to forget the list and "Do it!" You'll find the complete list at [www.baja-haha.com](http://www.baja-haha.com).

If you're new to the event, let us explain that the Ha-Ha is a 750-mile cruisers' rally from San Diego to Cabo San Lucas, with stops along the way at Turtle Bay and Bahia Santa Maria.

You'll find frequent updates on this year's event, in addition to all sorts of other hot sailing topics at *Latitude's* 3-times-weekly news portal, **'Lectronic Latitude** (found at [www.latitude38.com](http://www.latitude38.com)).

Summer  
is safe at  
Paradise



Enjoy  
your stay  
with us!

Paradise Village  
BEACH RESORT & SPA

011-52-322-22-66728 • [www.paradisevillage.com](http://www.paradisevillage.com)  
marina@paradisevillagegroup.com

**Nautical Books, Software, Charts  
and more!**



WAYPOINT

621 - 4th St., Oakland, CA

[www.waypoints.com](http://www.waypoints.com) • (510) 769-1547

## RIGGING ONLY

Standing and running rigging, lifelines, furlers, winches,  
headsail poles, main slider systems, windlasses,  
travelers, wire terminals, blocks and more...  
Expert advice for selection and installation.

Our  
26th Year! [www.riggingonly.com](http://www.riggingonly.com)  
(508) 992-0434 • [sail@riggingonly.com](mailto:sail@riggingonly.com)

**ICOM**

Award-winning Marine Communications Equipment

Handhelds • Mounted VHF • SSB • AIS

Visit one of our many West Coast dealers

[www.icomamerica.com/marine](http://www.icomamerica.com/marine)

**MONITOR**  
LINEWARE  
auto-helm

**SOS** Emergency  
Rudder  
Saye's Rig

**SCANMAR** Factory  
Direct  
INTERNATIONAL

432 South 1st Street • Pt. Richmond, CA 94804  
Toll Free: (888) 946-3826 • Tel: (510) 215-2010  
email: [scanmar@selfsteer.com](mailto:scanmar@selfsteer.com) • [www.selfsteer.com](http://www.selfsteer.com)

## West Marine

Call

**1-800-BOATING**  
(1-800-262-8464)

for a catalog or the store nearest you.



Est. 1973

## Almar Marinas

Everywhere you'd like to be  
[almar.com](http://almar.com)

# BAJA HA-HA XVII



## spinlock



The experts in rope handling and personal safety.

[www.spinlockusa.com](http://www.spinlockusa.com)



## MEET THE FLEET

Among the important dates to note (at right) is *Latitude's* annual Mexico-Only Crew List and Ha-Ha Party, September 8. There, hundreds of potential crew mix and mingle with Ha-Ha boat owners looking for extra watch-standers. Get a headstart on the process at our constantly updated Crew List site at [www.latitude38.com](http://www.latitude38.com). As many Ha-Ha vets will confirm, the best way to prepare for doing the event in your own boat is to crew for someone else first.

## VENTURA HARBOR BOATYARD

Full & Self Service Facility

(805) 654-1433

Two Travelifts • Haul Outs to 160 tons

[www.vhby.com](http://www.vhby.com)

Shoreside Work Slips • Emergency Repairs



Not just a marina – a cruiser's community  
Your best destination across the Sea...

[www.marina-mazatlan.com](http://www.marina-mazatlan.com)

011-52 (669) 669-2936 & 2937

[elizarraga@marinamazatlan.com](mailto:elizarraga@marinamazatlan.com)



Survive Your Dream

ECHO Tec Watermakers

604-925-2660

[www.hydrovane.com](http://www.hydrovane.com)



[www.downwindmarine.com](http://www.downwindmarine.com)

2804 Cañon St., San Diego

(619) 224-2733 • (800) 269-0241



[www.sandiegomarine.com](http://www.sandiegomarine.com)

2636 Shelter Island Dr., San Diego

(619) 223-7159 • (800) 336-7369

Mexico 001-500-336-7369



[www.sailingsupply.com](http://www.sailingsupply.com)

2822 Cañon Street, San Diego

(619) 225-9411 • (800) 532-3831

## ¿ MEXICO BOUND ?

GERRY

SEA of CORTEZ CHARTS

Accurate Navigation Charts & Guides

ELECTRONIC and PAPER

[www.GerryCruise.com](http://www.GerryCruise.com)

## Best Marina in Banderas Bay



MARINA RIVIERA NAYARIT

BY LA CRUISE

[www.marinarivieranayarit.com](http://www.marinarivieranayarit.com)

(52)3221350798

## The Ultimate Boat Organization Software

Perfect for the Ha-Ha and all offshore cruising:

- Digitally organize all your boat's documents & specifications
- Store manuals, diagrams, pictures, renewals & registrations
- Keep track of maintenance items required & completed
- Save for quick access all your favorite service providers



[www.BoatServiceLog.com](http://www.BoatServiceLog.com)

## IS THE PACIFIC PUDDLE JUMP IN YOUR FUTURE?

For many cruisers, the next logical step after cruising Mexican waters for a season or more is to hang a right and head west into the Pacific.

We call that annual springtime migration the **Pacific Puddle Jump**, and report on it heavily in the pages of *Latitude 38*. Making that 3,000-mile passage is one of the most thrilling accomplishments in the realm of sailing. Learn more at [www.pacificpuddlejump.com](http://www.pacificpuddlejump.com).

0D36887

Serving Boaters Since 1959

**MARINERS**  
GENERAL INSURANCE GROUP

## Cruise with Confidence

See Our Half-Page Ad In This Issue

(800) 992-4443

[www.marinersinsurance.com](http://www.marinersinsurance.com)

Newport Beach, CA • San Diego, CA  
Burlingame, CA • Seattle, WA  
Bradenton, FL • Puerto Vallarta, MX

# BROUGHT TO YOU BY THESE OFFICIAL SPONSORS

[WWW.BAJA-HAHA.COM](http://WWW.BAJA-HAHA.COM)



- Ultra Anchors • Ultra Swivels
- Quickline Flat Rope & Reel • Ultra Trip Hooks
- Ultra Chain Grabs, Ultra Snubbers & Ultra Bridles



[www.Quickline.us](http://www.Quickline.us)  
[www.UltraAnchors.us](http://www.UltraAnchors.us)  
[sales@Quickline.us](mailto:sales@Quickline.us)  
 714-843-6964

*The Best Marine Products from the World, for the USA.*



**KATADYN**  
 MAKING WATER DRINKING WATER

Watermakers that improve the cruising lifestyle.

**(800) 755-6701 • [www.katadyn.com](http://www.katadyn.com)**  
 email: [marine@katadyn.com](mailto:marine@katadyn.com)

**MARITIME INSTITUTE**  
 INCORPORATED



*Advanced Training for safer, more enjoyable passagemaking!*

**888-262-8020**  
[www.maritimeinstitute.com](http://www.maritimeinstitute.com)

USCG Approved **Classroom & Online Courses**



**Blue Sky ENERGY**

*'Solar Boost' charge controllers that combine solar/wind/hydro output for cruisers.*

**(800) 493-7877 [www.blueskyenergyinc.com](http://www.blueskyenergyinc.com)**



**La Paz Hotel Association**

November 18: La Paz Baja Ha-Ha Beach Fiesta on the Malecón at the Papas and Beer restaurant.

**011-52 (612) 122-4624**  
 or **(612) 125-6844**  
[www.visitlapaz.org](http://www.visitlapaz.org)

**IMPORTANT DATES**

**Sept. 8** — Mexico-Only Crew List and Baja Ha-Ha Party, Encinal YC in Alameda; 6-9 pm.

**Sept. 10** — Final deadline for all entries.

**Oct. 16** — Ha-Ha Welcome to San Diego Party, Downwind Marine, 12-4 pm. Ha-Ha entrants only.

**Oct. 23** — Informational Meeting about the Pacific Puddle Jump, West Marine, San Diego, 5 pm.

**Oct. 24, 9 am** — Final deadline for all crew and skipper waivers, West Marine, San Diego.

**Oct. 24, 11 am** — Skipper's meeting, West Marine, San Diego. Skippers only please.

**Oct. 24, 1 pm** — Ha-Ha Halloween Costume Party and Barbecue, West Marine, San Diego.

**Oct. 25, 11 am** — Start of Leg 1

**Oct. 30, 8 am** — Start of Leg 2

**Nov. 3, 7 am** — Start of Leg 3

**Nov. 5** — Cabo Beach Party

**Nov. 6** — Awards presentations hosted by the Cabo Marina.

**Baja Ha-Ha, LLC**  
 c/o 15 Locust Ave.  
 Mill Valley, CA 94941  
**[WWW.BAJA-HAHA.COM](http://WWW.BAJA-HAHA.COM)**

PLEASE NOTE: There is no phone number for the Baja Ha-Ha Rally Committee. Please don't call *Latitude 38* with questions. The Ha-Ha is a separate operation.



**MARINA DE LA PAZ**  
**FULL SERVICE MARINA**

*Conveniently located downtown*

**Tel: 011-52 (612) 122-1646**  
 Fax: 011-52 (612) 125-5900  
 email: [marinalapaz@prodigy.net.mx](mailto:marinalapaz@prodigy.net.mx)  
[www.marinelapaz.com](http://www.marinelapaz.com)



**BLUE PELICAN MARINE**  
 Nautical Consignments

*A Sailor's Consignment Chandlery*

Dealer for Lavac Marine Toilets

Located at Grand Marina  
**[www.bluepelicanmarine.com](http://www.bluepelicanmarine.com)**  
**(510) 769-4858**

**Dedicated AIS Collision Avoidance**



**vespermarine**

*"A really amazing piece of gear. I can tell it was designed by a sailor!"*

**(858) 405-5810**  
**[www.vespermarine.com](http://www.vespermarine.com)**

**THE BOAT YARD AT GRAND MARINA**

*"Where Service Has Meaning"*

Located in Alameda  
**(510) 521-6100**  
**[www.boatyardgm.com](http://www.boatyardgm.com)**



**Colligo Marine™**

*Bringing innovative solutions to the marine industry.*

Colligo Dux™ synthetic standing rigging • Emergency shroud kits  
 Bridle plate mooring systems • Furlers and much more.

**(480) 703-3675**  
**[www.colligomarine.com](http://www.colligomarine.com)**

# DEAR ABBY

**W**e want to thank everyone for all their comments, which were insightful and civil. We're sorry we can't print more of them, but there just isn't space. In fact, to get in as many responses as possible, we're using a layout that's as exciting as that in a phone book.

I followed Abby's trip because I was intrigued about some strange details. Abby's Open 40 is a very fast boat, so why were her speeds so slow? Her four-knot average is less than Joshua Slocum's when he went around more than 100 years ago on *Spray*. When Abby arrived in Cape Town, she didn't have 'goggle lines' on her face or a tan on her arms. Strange for a person after 100 days on the ocean. She must have been hiding in the cabin around the clock, with very little sail up after leaving the press behind, following the orders from her handlers. —*Wolfgang Stoeffl*

*Ed.— In Abby's defense, when Stephen Mann and Kathleen Torres of the San Diego-based Wylie 38 Tawodi sailed Abby's proposed course 18 months ago, they spent most of the time in the cabin because it was so awful and cold outside. As for the speed of Wild Eyes, as best we've been able to determine, Abby's daily averages in the Southern Ocean weren't that much faster than Robin Lee Graham regularly achieved 35 years ago with his pedestrian Lapworth 24, a boat with only half the waterline and sail area of Wild Eyes.*

I'm astonished at how you presented this story. Have a little respect for your fellow sailors, be they 16 or 60. Would you have responded the same way had it been Dame Ellen MacArthur or Sir Chay Blyth? —*Matthew Peacock*

*Ed.— If Chay or Ellen had been 16 and wanted to sail solo around the world, they would have gotten the same reaction from us. The fact that Jessica Watson managed to accomplish it has done nothing to change our mind. But here's a question for you: How young would be too young? 12? 10? Why not 8? While acknowledging that 18 is an arbitrary number, that's where we're drawing the line.*

I live in Cape Town, and all sailors down here know that doing anything but sailing north during the winter is risky at best. I assisted Jeanne Socrates of the Najad 380 *Nereida* when she stopped in Cape Town, unfortunately having to interrupt the same kind of circumnavigation via the Southern Ocean that Abby was trying to make. Jeanne was very disappointed to have to call off her trip,

but as an experienced and wise sailor, she decided to sail to Australia ASAP, then head north to the West Coast of America, from where she would try again next year. Our advice to her was to venture no farther than 40°S, even though it was still late summer. It seems that Abby was a bit deeper than that when she lost her mast, and this was in the Southern Ocean winter. I often think some sailors underestimate the vengeance of a large depression, particularly with the accompanying sea state. P.S. It's always a treat to read *Latitude* in cold Cape Town. —*Melvin Rautenbach*

Bully for *Latitude* in bringing this Sunderland fiasco to the full light of day. I hadn't been following Abby's exploits until I read about her EPIRBs going off. When I read she was in the Southern Ocean, I recalled that it was winter down there. At that point I knew she was either ignorant or out of her mind. —*Capt. John Raines*

I have 11 children, nine of whom sailed to Panama with me. All did amazing things on their own. I'd rather have my children doing adventures than staying at home and getting date-raped in high school, spending all their time watching digital junk on the internet, or getting drunk and killed in a senseless auto wreck. Get a life, old man. You forgot what it was like to be young, free, and adventurous! —*Tom Williams*

*Ed.— Might it be possible to come up with an adventure that has a much better risk-reward ratio, one that also wouldn't risk the lives of others in the pursuit of fame and fortune?*

I've done my fair share of singlehanding, and I believed all along that an Open 40 was too much boat and entirely the wrong choice for any novice sailors, be they 16 or 60. And no matter what spin Abby's family puts on her resume, you can't be anything but a novice sailor at age 16 — at least with regard to solo circumnavigating. Jessica Watson's team, on the other hand, picked the S&S 34, a boat that's stable, forgiving, comfortable in a seaway, and easy to power down, and which has proven itself in many ocean crossings — and now a solo circumnavigation. It's not surprising that Watson did a slow, safe loop around — and with a lot of class. Abby was destined for failure by the boat her team chose, the time of year she left, and above all, by her desperate need to set a record. The Southern Ocean is no place to be

when you're on a schedule, especially in winter. The best singlehanders in the world treat the Southern Ocean with the respect it deserves. How many of them broke their boats there in the last Vendée Globe? And that was in the summer!

The biggest factor in Abby's failure though was that she didn't really want to sail solo around the world, she wanted to set a record — a record she only had a certain amount of time to set. That misguided goal put her in a place she shouldn't have been, on a boat that was too much for her to handle. I think she's lucky to be alive. —*Rob Tryon*

Abby had no business being in the Southern Ocean at the start of winter. Did the Sunderlands think the girl wouldn't see any heavy weather, or was it, "No worries mate, we'll just call the closest maritime AAA and they'll come rescue her — and at no cost!"

During our 11-year circumnavigation, we found ourselves in the '98 'nightmare off New Zealand'. We remember how the Kiwi rescue crews risked their lives to save the lives of the Bermans on *Freya*, and how the crew of a ship risked their lives but were able to only save one of the two people on *Salacia*. Those rescue crews put their rear ends on the line to save those people. If a teenager and her family want to recklessly put their teen's rear end on the line, that's their business. But when you know there's a good chance that other people will have to put their lives on the line to save yours, it's time to pull your head out of your ass and re-assess. —*Buddy Ellison*

It's refreshing to hear a spade being called a spade. —*Nancy Rander*

It reminds me a bit of the balloon boy drama — except that they kept the kid safe in the attic so he wasn't in any real danger. —*Ken Fouts*

Abby's parents say that this was her dream since she turned 13. All her parents would have had to say was, "That's not going to happen until you're an adult and can make your own decisions, so dream about something else." I raised two kids into fine adults. Squashing unreasonable and unsafe dreams is called being a parent. —*Gary Ryan*

I've followed Abby's adventure from the beginning, and feel it was driven by the desire to be famous — no matter the cost. Then there was the fact of Abby's announcing her trip within days of

# COMMENTS FROM SAILORS

brother Zac's return, the rushed search for a vessel, the dash to Fort Lauderdale to get the boat to the West Coast, and the frantic scramble to prepare the boat in Marina del Rey. Not to detract from a great job done by Team Abby, but *Wild Eyes* was obviously not adequately prepared — as demonstrated by her need to stop in Cabo, by constant equipment failures, and by the constant problems with autopilots.

A slower boat, like Jessica's, could have taken advantage of the reliability of a self-steering vane. Without all the high-tech goodies, I suspect Abby might not have made it to Cabo. In fact, I think she was able to get as far as she did only because of her ability to be in constant contact with her support team via satellite phone, email, GPS, satellite transponders, weather routing and other whiz-bang goodies. The same, to a lesser extent, could be said of Jessica.

I do think Abby is a courageous young lady. I chatted with her and her father in the weeks before she left, and came away impressed by her intensity and quiet self-possession. I was somewhat miffed by the negativity and doom-saying from *Latitude*, but as time went on, I found myself more and more in agreement with you. I'm sorry to say that I feel Abby's attempt trivialized what is a very serious undertaking at any age. I'm happy she's safe, and wish her the best. Marina del Rey is a small place, so please don't use my name. —*Anonymous*

I'd be far less critical if I'd heard that Abby tried to self-rescue, was working on a jury rig, and hadn't attempted the Indian Ocean at less than the optimum time of year, and if she'd chosen a more sturdy boat. It would help if she and her family were not clamoring for publicity. As for the expense, trouble and danger in which their poor decisions and lousy character have put so many, without apology, that's unforgivable! —*Brooks Townes*

Just think if Abby had been told that she could go on the voyage, but couldn't get assistance via the radio or satphones, and wouldn't be allowed to have emergency locating devices. —*John Vissat*

*Ed.*— *To be fair, these days even the greatest sailors go around with satphones and EPIRBs.*

I could not agree more with *Latitude*. People are losing perspective and cheapening the achievements of others who take adventures on the sea, but in a seamanlike manner. —*Eric Tulla*

Last time I looked, we were free to do whatever we wanted or could afford to do. I could be wrong, but this was Abby's pursuit. Go Abby! —*Ron Day*

*Ed.*— *When is the last time you looked? Twelve-year-olds can't drive, you can't smoke in buildings, you can't fire automatic weapons in downtown San Francisco, you can't rent your kids out for sex . . . need we go on? Society prohibits all kinds of things, and usually — but certainly not always — with some reasonable justification.*

Parents are not perfect, but I would have hoped for more responsibility on the part of the Sunderlands. If parents want to hide behind a veil of religious immunity, so be it, but the sea is the great equalizer. —*Matthew Krohn*

As I sailor who doesn't want to see useless 'nanny state' legislation be the result of all this, I agree with your thoughts on the Abby fiasco. The Sunderland parents should face child endangerment charges, as they willfully put their 16-year-old daughter, an inexperienced minor, in harm's way. The Southern Ocean in winter is so predictably dangerous even the world's most talented and experienced sailors stay away. How is what the Sunderland parents did any different than a parent leaving a kid locked in a hot car on a hot summer's day? Death is a very likely possibility in both cases. If the Sunderland parents were brought up on criminal charges, it might dissuade others from pulling similar stunts for media attention. —*Bob Rynd*

What were they thinking?! The risk of death — or at least serious injury — was written all over this venture. Without adequate experience negotiating a hostile environment, doing the nearly impossible, it was crazy from the outset. The parents should have been jailed, and so should anyone else who might have been able to stop this insane attempt but didn't. I'm talking about Wilbur and Orville, of course. And any test pilot. And any astronaut. —*Rich Johnson*

*Ed.*— *How many 16 year-olds have there been in the astronaut programs?*

Couldn't agree more with your thoughts. And after the dismasting, Abby leaves the rig to trail behind her boat for days? After spending \$400,000, they didn't think to throw in some bolt-cutters? —*Rob Wilkinson*

Only running backstays +

singlehanded + Southern Ocean in the winter = criminally irresponsible parents!  
—*Ed Fagan*

I have nothing but admiration for what Abby has done. [*Editor's note: This is followed by a modified version of a long and famous Teddy Roosevelt quote saying to strive valiantly is better than being a "cold and timid soul."*] —*Paul Slivka*

I commend *Latitude* for a great commentary on Abby. As a parent and someone who knows many of the marine industry folks who helped both Zac and Abby prepare for their over-hyped trips, I feel sorry for both kids. I feel they missed out on some great adventures and opportunities to grow. —*Brendan Huffman*

I concur with your position — with the caveat that our whole society is so screwed up that we will take 'heroes' anywhere we can find them. Such as movie stars, American Idols, and little girls who don't have a clue. —*Walt Lawrence*

I think you're dead on the money on this one. 1) There are crews of 56 boats sailing in this year's Pacific Cup that are spending an order of magnitude more time and effort to preparing their boats for a summertime jaunt to Hawaii than the Sunderlands spent in preparing their daughter to sail non-stop around the planet via the Southern Ocean. 2) Abby wouldn't have been allowed to sail in the Singlehanded Sailing Society's LongPac, let alone the Singlehanded TransPac, because she'd never been in command of a vessel singlehanded under sail before. 3) The Sunderlands have heavily censored any comments to Abby's blog, including any and all comments that cautioned against traveling the Southern Ocean during the winter. —*Nick Salvador*

I'm wondering if there isn't some sexism in all the criticism of Abby. When Robin Lee Graham did his well-publicized circumnavigation in the '60s, he was also 16. While he did the westerly coconut run, there wasn't GPS, EPIRB, satphone or even accurate weather forecasting. Yet he did it in a 24-ft boat. I'd say his risk was at least on par with Abby's. And it's not just the times, as a bigger issue was made over Abby and Jessica Watson than over brother Zac and young circumnavigator Mike Perham. —*Chris Northcutt*

*Ed.*— *There surely has been sexism — and ageism. If Abby had been a 60-year-old guy, nobody would have even heard about it, and the Aussies*

# DEAR ABBY

certainly wouldn't have spent hundreds of thousands to send a Qantas airliner looking for him. While Abby and Jessica's attempted circumnavigations are apples and box wrenches compared to Robin Lee Graham's, one could argue that the sum of the risks was in some respect comparable. All were much greater than Zac's which, not to be disrespectful, was a circumnavigation ordinaire.

It's nice to know, when trying to decipher mainstream media, that I'll get the straight poop from *Latitude*. But with all due respect, I think you've been a wee bit over the top in your criticism of Abby. In following her blog, I got the impression of a very competent, mature and gutsy sailor. I was especially impressed when she spent many hours crammed into the lazarette working on the failing autopilot. As for your criticisms regarding seeking money and fame and her sponsorship money, how's that different from Vendée Globe participants? I'm with you 100% regarding the parents' decision-making process. It isn't the first time I've noticed that when people "pray over it," God always seems to tell them what they want to hear, especially if there are financial considerations. —Peter Tarbox

*Ed.— Participants in the Vendée Globe and similar races have to be highly experienced sailors, and they are adults. None of the child circumnavigators would have qualified for such events.*

I had the same reservations as *Latitude* about a youth departing on such a circumnavigation, but my adventure-loving side was conflicted. However, sailing into the Southern Ocean during winter is insane. And using 'pimp' to describe what Abby's parents did was being kind. —Dave Hamilton

I agree with most of your post, especially the part about her leaving during the Southern Ocean winter. If they were so well-funded, I'm wondering if they contracted with a sophisticated sailing weather routing service, and, if so, why she wasn't tracked to avoid those bad conditions. —Bill Waterhouse

*Ed.— Commander's Weather, which has provided weather forecasting for many of the great race boats in the Southern Ocean, and which provides weather reports for the Ha-Ha, provided weather forecasts. After Abby ran into trouble, the information on Abby's website suddenly changed, and said that Abby's parents, not Commander's, were responsible for her route. We were frankly surprised to see that Abby was so far south. On the*

*other hand, trying to keep her out of bad weather in the Southern Ocean in the winter, particularly with speed so slow, would be like trying to keep her in less than five knots of wind while crossing San Francisco Bay on an afternoon in June. It just can't be done. By the way, the weather at the time of Wild Eyes's dismasting wasn't good, but for the Southern Ocean, it wasn't particularly bad.*

A very good article you put together on the Sunderland operation! Although in my 70s, I feel more than a little kinship with Abby, having been imprinted and home-schooled myself. What I lacked to do the same thing was a 'Little League push' that evidently was a big part of the Sunderland kids' upbringing. —Warwick 'Commodore' Tompkins

*Ed.— As we recall, Warwick sailed across the Atlantic six times and rounded the Horn before he was four years of age. But he wasn't alone; he did it with his parents aboard the schooner Wanderbird.*

It's not for us to decide whether Abby should have made the trip or not. At 16, I was jumping freight trains to Mexico. Abby is more precocious than the armchair sailors who are going to object to her adventure. —Jerry Metheany

Sailing solo nonstop around the world is as much about a person's ability to maintain and repair things as it is about a person's ability to sail. Although I commend Ms. Sunderland on her courage, I also question her ability to handle difficult situations and her ability to fix problems on her boat. —David Gill

*Ed.— How hard is the sailing part of sailing around the world? After Mike Harker of Wanderlust 3 singlehanded his Hunter 49 solo around the world, he insisted he still didn't really know how to sail. Other circumnavigators have described themselves as 'travelers' as opposed to 'sailors'.*

Abby may be a very good sailor, but she lacks the wisdom to deal with the choices that need to be made in a venture such as the one she undertook. And she had the wrong boat! The survival odds were stacked against her on a lightweight boat. Zac's Islander 36 was shorter, but displaced more than double Abby's Open 40. Light boats are less forgiving, and I'm speaking as an Express 27 sailor. I wonder if the Open 40 was chosen by her father because it was faster and would improve her chance of setting the record. The wrong boat and wrong time of year

— two bad choices that could have led to disaster. —Larry Laney

It takes more than sailing ability to run a boat on the ocean. You need to be experienced and mature enough to understand your and your boat's limitations — and the implications your decisions and actions have on the health and lives of others. I wonder how Abby's parents would have felt if someone had gotten hurt or killed coming to her rescue? —Rick Daniels

It's Balloon Boy, Part II. I don't know how you get around child endangerment. Divine providence be damned, there are numerous misguided fundamentalists who have killed or maimed their children. The Sunderlands should pay anyone who was kind, responsible and brave enough to come to Abby's aid. And if the Aussie rescue services won't take the money because "it's what we do," they can donate it to Aussie child protective services. —Dave Stromquist

I watched an interview with Abby's parents in amazement as they explained she would take the Southern Ocean route because it was safer than going through "all those countries full of pirates and just waiting for this little pretty blonde thing." That's almost a direct quote. Her parents are absolutely delusional! I am very mad about the whole thing because the circumnavigation "through all those countries" is the reason that we do it! Abby's parents are the epitome of "ugly Americans", isolated from the rest of the world and plotting how to get famous. And this bringing God into all their sailing misadventures is really revolting. —Marek Nowicki

I think that there should be three types of circumnavigators: 1) Tourists. For example, like on the *Alaska Eagle*, which I have sailed on a couple of times. 2) Assisted, meaning with the use of satphones and weather routing. 3) Unassisted, for those who have done it all by themselves. I think that Abby is like many other sailors who are provided assistance from shore, and who themselves do not have the skills to take a boat around the world alone. As my nephew would say, "They are posers." In my opinion, Abby was doing an assisted circumnavigation. It's kind of like those people who go on guided tours up Mt. Everest. —John Gorton

*Ed.— We can't think of anyone who hasn't gone around without some kind of*

# COMMENTS FROM SAILORS

assistance, even if it's casual rather than professional. So we think you'd need to distinguish not between Assisted and Unassisted, but levels of assistance.

To top off everything this Abby child has done, her failure to scuttle her boat demonstrates her continued irresponsibility. And the irresponsibility extends to daddy and the shoreside support team, who should have reminded her to clean up her mess so it wouldn't become a hazard to navigation. —Hugh Sage

Think of all the crews of big strong guys that cry "Mommy!" a few miles from port in moderate conditions after borderline breakdowns. That's not what happened here, so let's admire what Abby did accomplish and separate that from the criticism of her parents and the way they set up *Wild Eyes* and the voyage. —Pat Byrnes

I really admire Abby's herculean effort. My 8-year-old daughter and I have enjoyed following her blog together. I

know what Abby's done will compel young children to strive for bigger and better things. Yes, Abby's parents are foolish for letting her go into the Southern Ocean during winter, but that aside, I hope the sailing community separates the decisions her parents made from what Abby did accomplish. For God's sake, she rounded Cape Horn. That would be a life's achievement in my book of adventures. —Tom Price

Ed.—Fair enough. But what would be "bigger and better", your daughter sailing around solo at age 14?

I am an Aussie and I live in OZ. I'm really happy that Abby is safe, and want everyone to know that we Aussies don't mind rescuing people in distress. That is our nature. But we expect the mom and dad to give their kid a strong talking to when the welcome home hugs are over. But I don't think that will happen in this case, because the mom and dad are as thick as doggy doo. It will be up to the press to do it, but that won't happen either, will it? I bet there are deals already

done to make a buck. The only way to put an honest face on the episode is to pay the rescuers and the Aussie government. —Jim Hammond

Ed.—While there are differing opinions, the Sunderland parents have been taking a drubbing in even the mainstream press.

Although Ms. Sunderland's age has been the focus of her adventure, I was very impressed with your editorial on her accomplishments and ultimate rescue — appropriately pointing out the difficulty of what she was undertaking, regardless of age. When I saw on the news that she had set off her EPIRBs, I was worried that the media were going to slam her — and some did — for being just 16 years old. *Latitude* has continually pointed out and celebrated her accomplishments — which makes me very happy. I hope that her story inspires parents to continue to support the adventures and dreams of their daughters, because I know that it isn't always easy. Just look at my dad — he has four of us! —Mollie K. Hagar, Modern Sailing School & Club



**SAVE**  
on North Sails  
quality, durability  
& performance!

**NORTH SAILS  
direct**

It's easy to measure your own boat  
and SAVE on the world's best  
cruising and racing sails. Log on to  
[northsailsdirect.net](http://northsailsdirect.net)  
or call 888-424-7328.

Free tape  
measure  
with every  
order!



**Achilles**

**MEXICO'S  
BEST  
TENDER**

**ONLY HYPALON  
THAT SURVIVES  
TROPICAL SUN**

Best Materials  
Best Construction  
Best Price – Best **VALUE!**

Call for  
**MEXICO  
CRUISERS  
SAVINGS!**

**SAL'S  
INFLATABLE  
SERVICES, INC.**

**PHONE (510) 522-1824  
FAX (510) 522-1064**

1914 Stanford St., Alameda 94501  
[salsinflatables@sbcglobal.net](mailto:salsinflatables@sbcglobal.net)  
[www.salsinflatableservices.com](http://www.salsinflatableservices.com)



# DELTA DITCH RUN



*Multi 1&2 overall winners Pease and Jay Glaser were second-fastest to Stockton.*



JEREMY LEONARD/SURFCITYCATAMARANS

ERIK SIMONSON/WWW.H2OSHOTS.COM

—**H**alfway through the 67.5-mile race, while folded over the lower lifeline of my ride for June 12th's Delta Ditch Run, I thought, "Yucca has to be crushing everyone right now." That should give you a clue about the 20th edition of this, errrr . . . "downwind" classic hosted by Stockton Sailing Club and Richmond YC. With a northerly breeze that ranged from 8 to 25 knots, a double-head rig would have been more useful than spinnakers



---

# — YOU'VE COME A LONG WAY, BABY

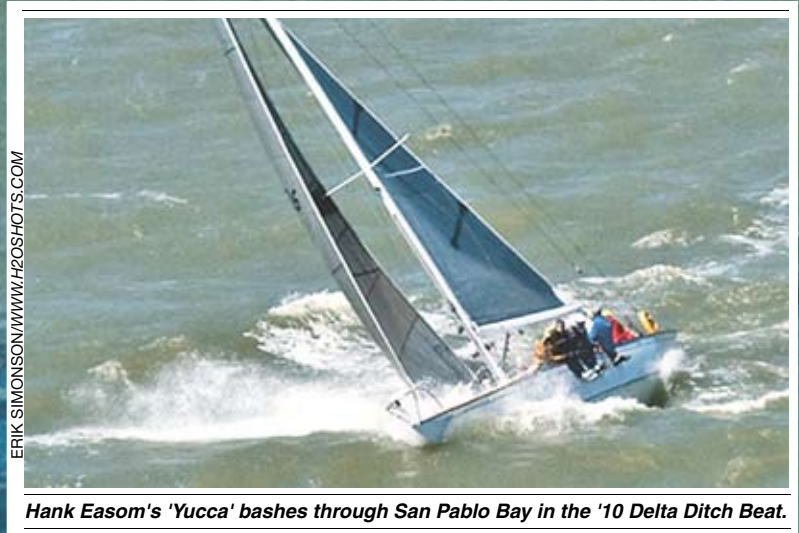

**Hank Easom's 'Yucca' bashes through San Pablo Bay in the '10 Delta Ditch Beat.**

---

## **Spread — Stephen McMillan's Melges 24 'Mako' blasts through a San Pablo Bay mogul.**

---

most of the time.

The healthy flood turned San Pablo Bay into a frothing mess as it met the 25-knot northerly that greeted the 144 monohull and 22 multihull starters. After a short spell where the breeze dropped into the mid-teens off Pt. Pinole, it was full-on from there. In fact, it was so un-Ditch Run-like that 33 monos and seven multis decided to call it a

day — many before they'd even reached Benicia. Ironically, none of the six boats in the Cruising Division decided to call it a day!

Although the kites would ultimately come out of the bags for short stints, it wasn't until about the last seven miles that they went up for good.

While we couldn't see *Yucca*, Hank Easom's 8 Meter, we figured the condi-

tions that kept everyone in headsails all the way through San Pablo Bay and at many points beyond, were working out perfectly for the venerable woodie.

The overall win prediction wasn't a hard one to make, given that Easom probably spends as much, if not more, time on the water as anyone else on the Bay and has won what we're guessing is just about everything on the Bay at this point in his life. It turned out that *Yucca*

# DELTA DITCH RUN

ERIK SIMONSON/WWW.H2OSHOTS.COM



RYCPHOTO



ANDREW MCEWAN



DAVE KEANE



RYCPHOTO



ERIK SIMONSON/WWW.H2OSHOTS.COM



ERIK SIMONSON/WWW.H2OSHOTS.COM



JOHN CURREN

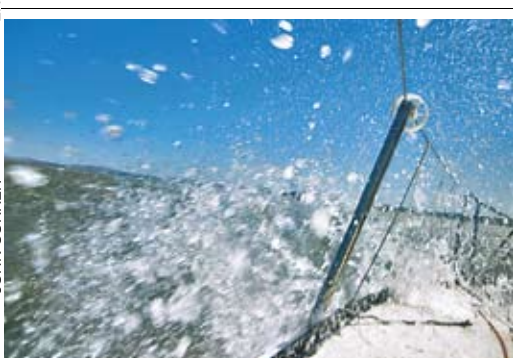

ANDREW MCEWAN



**Clockwise from top left — Jason Moore's 'Tiger' eviscerates San Pablo Bay; Tim and Karin Knowles 'Lilith' and Sam McFadden's 'Dragonsong' are split by a tanker, interestingly enough the 'Dragonsong' is the Knowles' previous boat; the crew of 'Stewball' in the Delta mode; yet another great view of the bash up San Pablo Bay; Pegasus 32 ticks off a daymarker on the way to Stockton; Lauren Goché came all the way from Portland, Oregon to do the race on overnight notice, only to be on the losing end of the new game "drop-the-full-beer-on-the-swimmer's-head"; the barbecue is standard racing equipment aboard Ben and Jennifer Braden's Moore 24 'Uff Da', up ahead is Deke Klatt's turboed Pyramid 660 'Squirt'; Sunset on a slough; 'Ciao!' chases 'Warpath' and 'Water Wings'; the view from aboard an Express 27 in San Pablo Bay; 'Tuki'; workin' hard aboard 'War Pony'; 'Bad Hare Day' hangs with 'Infrared'; the Moore 24 start.**

did in fact take the overall monohull title for the race, finishing the nominally-67.5-mile race in 8h, 34m, 34s and correcting out more than 11 minutes ahead of David Holscher's Cal 40 *Henry Hannah*.

*Yucca* took Heavy 1 in the process, and *Henry Hannah* Heavy 2. Heavy 3 went to Tom Blagg's Olson 25 *Pearl*, who

pipped event chair Bob Doscher's Columbia 5.5 Meter *Bada Bing* at the post. Light 1 went to Philippe Kahn's Melges 32 *Pegasus 32*, which also won the unofficial Melges 32 title — there were four in the race. One, Steve Howe's *Warpath*, came from as far away as San Diego. The top-three in Light 2 were all Olson 30s, with Lesley Randall's *Enigma* taking

the top spot. The seven-boat Melges 24 division went to Santa Barbara's Kent Pierce and his *Average White Boat*, which sailed anything but an average race, finishing some 12 minutes ahead of Kevin Clark's very competitive, Alameda-based *Smokin'*. Fifteen Express 27s started, but only ten finished and it was Brendan Busch's hull #1 *Get Happy!!* that came



ERIK SIMONSON/WWW.H2OSHOTS.COM



RYCPHOTO



DAVE KEANE



DAVE KEANE



RYCPHOTO



MARIANNE ARMAND

out on top. Erik Menzel's *Bad Hare Day* did anything but live up to its name, winning the Wabbit division and coming in third overall. Finally, 30 Moore 24s started, 24 finished, and in what should come as no surprise, the division went to Hank Eason's nephew Scott aboard his tuxedoed *Eight Ball*.

Among the multihulls, Olympic medalists Pease and Jay Glaser's F-18 *Breakfast at Bill's* took the honors in the eight-boat F-18 division and the overall multihull honors on the strength of an elapsed time of only 6h, 3m, 5s. The Glaser's time was second only to Roger

Barnett's ProSail 40 *Tuki*, which finished in 5h, 13m, 28s, taking Multi 1 — which featured a smattering of non-F-18 beach cats and the big, bad, charcoal-gray wolf that was dressed in decidedly wolf-like garb, plus Pat Barrett's Viva 27 *Cat Sass*, back for more after a hellacious pitchpole in last year's race.

Richard Paul's Meritt 22 NS *Irrational Behavior* won the six-boat cruising division after finishing in a seemingly irrational 11h, 29m, 40s. But Paul's wasn't the last boat on the course. Far from it actually — Dana Smith's Challenger *Libertine*, with a rating of 264, took 17h,

30m and 52s to finish the course and deserves a mention for sticking it out as the wind dropped Saturday night.

Beyond the fact that it gets warmer the farther you get up the San Joaquin River, one of the Ditch Run's greatest attractions is the awesome party that greets you when you get there. This year was no exception. A vegetarian's nightmare, the very reasonable Tri-Tip dinner — tacos were an option, but after seeing the meat they didn't get a second thought — showed the kind of attention to detail that has this race drawing boats from all over the state. Not only was it

# DELTA DITCH RUN

well-prepared, the volunteer crew at Stockton SC sliced the succulent meat into slices so thin you didn't need to bust out your rigging knife to cut it.

With this year marking the race's 20th anniversary, a look back at the July 1991 edition of *Latitude 38* told us a lot about the genesis of this race. Originally conceived as a feeder race for the Stockton SC's 140-mile test of adulthood — the South Tower Race which goes from Stockton to Blackaller and back to Stockton, the Delta Ditch Run has indeed truly eclipsed its forbearer as was posited in our coverage of the first race. With 173 starters, the race shows no signs of slowing down. Given the effort put in by the Stockton SC, we'd be surprised if it doesn't keep getting bigger.

— *latitude*/rg

## THE DELTA DITCH RUN (6/12)

MONOHULL OVERALL — 1) **Yucca**, 8 Meter, Hank Easom; 2) **Henry Hannah**, Cal 40, David Holscher; 3) **Bad Hare Day**, Wabbit, Erik Menzel; 4) **Pegasus 32**, Melges 32, Philippe Kahn; 5) **Redhead**, Cal 40, Walter Smith; 6) **Viva**, Melges 32, Don Jesberg; 7) **Mr. McGregor**, Wabbit, Kim Desenberg; 8) **Taboo**, Melges 32, Stephen Pugh; 9) **SuperFly**, Cheetah 30, Steve Mollering; 10) **Average White Boat**, Melges 24, Kent Pierce. (144



RYCPHOTO

Steve Stroub's SC 37 'Tiburon' getting a little fuzzy for the camera in the Delta heat.

boats)  
HEAVY 1 — 1) **Yucca**; 2) **Stewball**, Express 37, Bob Harford; 3) **Marrakesh**, Express 34, Craig Perez. (11 boats)  
HEAVY 2 — 1) **Henry Hannah**; 2) **Redhead**; 3) **Lilith**, Wyliecat 39, Tim Knowles. (18 boats)  
HEAVY 3 — 1) **Pearl**, Olson 25, Tom Blagg; 2)

**Bada Bing**, Columbia 5.5 Meter, Bob Doscher; 3) **Gypsy Lady**, Cal 34-1, Val Clayton. (17 boats)

LIGHT 1 — 1) **Pegasus 32**; 2) **Viva**; 3) **Taboo**. (16 boats)

LIGHT 2 — 1) **Enigma**, Olson 30, Lesley Randall; 2) **Dragonson**, Olson 30, Sam McFadden; 3) **Hoot**, Olson 30, Andrew Macfie. (16 boats)

MELGES 24 — 1) **Average White Boat**, Kent Pierce; 2) **Smokin'**, Kevin Clark; 3) **Bandit**, Mike Wolfe. (7 boats)

EXPRESS 27 — 1) **Get Happy!!**, Brendan Busch; 2) **Magic Bus**, Paul Deeds; 3) **Shenigans**, Bill Moore. (15 boats)

WYLIE WABBIT — 1) **Bad Hare Day**; 2) **Mr. McGregor**; 3) **Jack**, Melinda Erkelens. (8 boats)

MOORE 24 — 1) **Eight Ball**, Scott Easom; 2) **Paramour**, Rowan Fennell; 3) **Banditos**, John Kernot. (30 boats)

CRUISE — 1) **Irrational Behavior**, Merit 22 NS, Richard Paul; 2) **Coyote**, Wylie 34 Mod., Peter Yates; 3) **Ghost**, Ketch, Bill Goldfoos. (6 boats)

## MULTIHULLS

F-18 — 1) **Breakfast at Bill's**, F-18, Pease & Jay Glaser; 2) **Sling Shot**, F-18, Phillip Meredith; 3) **Ocho**, F-18, Craig Yandow. (8 boats)

MULTI 1 — 1) **Tuki**, ProSail 40, Roger Barnett; 2) **Rojo Rojo**, Nacra 20, David Meacock; 3) **Pip-pin'**, Hobie 16, Gary Russell. (13 boats)

MULTI 2 — 1) **Water Wings**, F-31RS, Jim Lawson; 2) **Papillon**, F-27, Andrew Scott; 3) **Wingit**, F-27, Amy Wells. (8 boats)

Complete results at: [www.stocktonsc.org](http://www.stocktonsc.org)

## KISSINGER CANVAS

Marine Canvas & Interiors  
STEVEN KISSINGER  
(925) 825-6734  
Covering the Entire Bay Area



- Biminis
- Boat Covers
- Cushions
- Sail Covers
- Headliners
- Awnings

## DODGERS

Side handrails and window covers included.

## OPTIONS

Aft handrail, dodger cover, sailing bimini.

Free Estimates and Delivery



Port Townsend, WA  
since 1975

## Featuring:

Port Lights in 316 Stainless Steel,  
Bronze and Copolymers  
starting at \$109.95

New full line of inflatables  
starting at \$596 + free shipping

See us at the  
Port Townsend  
Wooden Boat Festival  
Sept. 10-12



Deck Wash  
Cleats • Handrails  
and Other  
Marine Hardware

See catalog on the website:

[www.newfoundmetals.com](http://www.newfoundmetals.com)

Toll Free: 888.437.5512

nfm@newfoundmetals.com • 360.385.3315

# Think Of It As Roadside Assistance For Your Boat



Of course you have roadside assistance for your car, why wouldn't you have towing for your boat? Breakdowns on the water happen all the time and without BoatU.S. Towing service, it could cost you \$600 out of your own pocket, every time. Plus, with our towing service there's no claim made against your hull insurance so it won't affect your premiums.

- On-the-water towing, soft ungroundings, jump starts & fuel delivery
- 24/7 dispatch and assistance
- Applies to ALL recreational boats you own, borrow or charter
- Unlimited towing \$149 for saltwater/freshwater boaters and \$58 for freshwater only

**Get Unlimited towing from BoatU.S. Towing services—Join today!**

**VESSEL ASSIST®**  
Towing You Can Trust  From BoatU.S.

**800-888-4869**  
**BoatUS.com**

\*Service provided during normal boating seasons. Details and exclusions can be found online at BoatUS.com/towing or by calling.



*A wild downwind ride.*

A new 20-foot club racer with carbon-fiber keel, spars, bowsprit and rudder. Lightweight and trailerable with a retractable keel. Available this summer.

LOA	LWL	Beam	Draft	Displ.	Spar
19' 6"	18' 0"	5' 11"	4' 6"	835	Carbon

*Ready to Race for \$24K*

landingschoolboats.com

207-985-7976

**REPAIR  
REPAIR  
REPAIR**

**ROOSTER SAILS  
A REPAIR LOFT**

**NOW AT  
GRAND  
MARINA**



**YOUR ROLLER  
FURLER UV COVER  
SPECIALIST**

**ROOSTER SAILS**

2021 Alaska Packer Place, Box 18, Alameda  
**(510) 523-1977**

**www.roostersails.com • rui@roostersails.com**

Open M-Th 9-6 • Fri 9-5 • Sat by appt.

Owned and Operated by Rui Luis • Experienced Sail Repair and Fabrication

**NOW OFFERING NEW CRUISING SAILS!**

**SAIL REPAIR SPECIALISTS • COMPETITIVE RATES • RECUTS • CONVERSIONS**

# BOATYARD TOUR

Every spring we grab our trusty Nikon and digital recorder and head out to any number of Bay Area boatyards to chat with folks working on their boats. Normally we'll find a few here, one over there, and a few more in between — only once have we been completely skunked — but this year we hit the motherlode of DIYers on our very first stop.

Usually we set out on our quest in April or May in order to catch all those boatowners getting ready for the upcoming sailing season. And while we did take this year's tour in May, we ran out of space in the June issue to run the story. We tell you this only to inform you that most — but not all! — of our subjects have likely been happily sailing for more than a month.

One of the things we love most about the Bay Area is that the types of boats people sail — and the way they sail them — are as diverse as the population. On our one stop we met many new boat owners, though not all are new sailors. We met old friends who have sailed together for years, and newly single sailors eager to explore their independence. Some were planning long-term cruises, others were happy to simply daysail the Bay. A few boats were out for a quick bottom job while others had been on the hard much longer. There were even a couple of canines supervising their silly, water-obsessed humans.

The one thing all boatowners had in common was their obvious passion for their boats. For some sailing may be a pastime, for others it's their livelihood, and for the remainder it's their life. But no matter how entrenched they are in their sport, none made a secret about how much they value time spent on their boats, and the care that they were taking in putting them together. We salute them for it.

— *latitude/ladonna*



**Wind Song**, Islander 29 — Any amount of time spent in the yard is usually too long for most sailors, but some are more patient than others. Take Bob Ambroz, for example. Bob bought *Wind Song*, a 1966 classic, a year and a half ago — after a 25-year hiatus from sailing — and had her hauled within six months. Yes, you read that right; *Wind Song* has been on the hard for a year! When asked how much longer he had to go, Bob replied, "Not too much longer, a couple more months."

While we're not envious of what his yard bill is going to look like when he finally splashes, we couldn't help drooling over what is essentially a brand new boat. "We replaced all the bulkheads, and painted everything inside and out, top to bottom," said Bob. "I installed a new fresh water-cooled engine, tranny, prop shaft, prop, wiring, tinted windows, you name it."

Bob's being voice and data telecommunication technician by trade, and a Harley lover at heart, we were curious what brought him back to sailing. "I got a divorce," he noted dryly, then went on to explain. "I'd lived on a boat before I got married, and had a great time sailing every day. Those were some good times in my life and I want to get back to that." Who can blame him?

## — DIFF'RENT STROKES



**La Bonita**, Lyndsey 30 — "Schedules are laughable," says Cynthia Shelton, who officially began cruising — read, quit her administrative job at Stanford and cast off from her slip at Pete's Harbor in Redwood City — two weeks before we met her. "If that bothers a person, they really shouldn't go cruising. I'm practicing not letting it bother me."

And Cynthia got a lot of practice during her haulout. As so often happens, small issues kept popping up — including several days of rain — that forced her to delay painting her topsides. "I'm only one week over schedule — that's not too bad," she chuckled.

Relatively new to sailing, Cynthia has embraced the sport — and the lifestyle — with gusto. In the two years she's owned *La Bonita*, her first boat, she's completely revamped the interior, a process she documented on her website [www.cynxing.com](http://www.cynxing.com). "Working and living aboard is a 24/7 experience," she noted.

Once work on *La Bonita* is complete, Cynthia plans to "head south." How far south is a question she's not ready to answer quite yet. "I'll play it by ear," she said. "The rhythm of not knowing is very different. I can't make long-term plans."

Whatever direction the winds end up taking her, Cynthia won't be alone. First Mate Austin, a small, white rescue dog she believes is part terrier, part Italian greyhound, will be at her side. "I was looking for a dog that would fit on the boat but would still be able to get around on its own. When I found Austin, I fell in love."

As for the idea that this multi-talented sailor, who plays guitar and banjo, as well as drawing her own liveaboard comic, is retired, don't even think it. "I may not have a job," said Cynthia, "but I'll be working till the day I die!"

**Raven**, Santana 22 — Boat partnerships can be a tricky business. One partner uses the boat more, cleans up less or just plain gets on everyone's nerves. All too often, partnerships are dissolved on less-than-amicable terms. But Aran Kaufer, Decker Flynn and Ian Goertz are a case study in how to make such an arrangement work.

"Prior to buying *Raven* in '01, we owned a '69 Ford Galaxie 500 together," said Ian, "so we were practiced in sharing old vehicles." As Aran noted, they "knew the pitfalls of co-ownership."

This trio of Cal grads met way back in '88, having hailed from different parts of the country — Aran from Santa Barbara, Decker from Seattle and Ian from Texas. All had sailed as kids, but Ian and Aran acknowledge that Decker, who has the most experience, is skipper aboard *Raven* during their frequent daysails.

"Our favorite thing to do is cruise around the Bay," said Aran. "We have a favorite anchorage off Angel Island, but I can't tell you which one; otherwise everyone will go there." We promised not to reveal their secret so you'll just have to explore the island yourself to find your own favorite.

As dads, all three look forward to introducing their young kids to the joys of sailing but, right now, they're all too young. "My daughter's six, so I bring her to the boat sometimes," Aran said, "but my son's too small."

One thing they'll have to teach their kids is to always be careful around boats — which is a lesson Decker learned the hard way during their quick bottom job haulout. "See this Band-Aid?" he asked, pointing to his forehead. "I bashed my head on the outboard. Five stitches!" To prevent further accidents, his ever-caring partners draped a bright yellow PFD on the offending prop. Now *that's* how a partnership should work!



# BOATYARD TOUR

ALL PHOTOS LATITUDE / LADONNA

**Quattro Mari**, Catalina 30 — Mike and Joanne Crosby are no strangers to boats; they owned a powerboat for years when they lived in Austin, Texas. But when the time came to choose between the boat and their daughter's college education, the boat lost.

So when the couple moved to the Bay Area four years ago for Mike's work — he sells large equipment to the marine industry; in fact, his machines helped build *BMW Oracle* — they decided they wanted to get back into boating. "I didn't want to sit in the back again while he played captain," said Joanne. "We wanted something physically and mentally challenging to learn." They did their research and found that the Catalina 30 fit their needs perfectly.

They finally bought their dream boat a year ago, but then "life got in the way," Joanne explained. They dutifully had a diver clean *Quattro Mari's* bottom every three months, and when he said it was time for a bottom job, they realized they needed to refocus on their boat.

"We're planning to take a sailing course," said Joanne, "mostly to learn the basics but also so we can get certified to charter boats on our frequent trips to Italy. Then we'll hire an instructor to teach us on our boat."

In the meantime, they've torn apart the interior, adding Corian countertops and making a completely new set of cushions. "I have new countertops and two industrial sewing machines to make my cushions, but I still don't know how to sail!" laughed Joanne. But we're not worried — their spirit and zest for life, not to mention their desire to teach their grandkids how to sail, will keep them motivated. Don't be surprised if they sail past you one day very soon.



**Old Buffalo**, Pan Oceanic 46 — Who can argue with love at first sight? Ruben and Robbie Gabriel sure can't because they've been struck with it twice: first when they met each other in a boatyard a few years ago, then again a few months ago when they laid eyes on the boat they absolutely, positively were *not* going to buy. "Honestly, we were just going to look at it to see if we were comfortable with the size," Ruben insisted. That's a lovely story, but there's actually a little more to it.

"An extremely experienced sailor friend told us that his very favorite boat was a Pan Oceanic 46," related Robbie. "He said he'd even commissioned one in Taiwan in the '80s and had loved sailing it. So we looked on the internet and, of two for sale in the whole world, one was here. After deciding this was the boat for us, we asked Bruce to come look at it. Would you believe that this was the exact same boat he commissioned in '81? The owner even had a photo of him and Bruce sailing her!"

With the purchase of the new boat, though, something had to give as they already had two other boats, a Moore 24 named *Kismet* and a Newport 30 Mk II named *Winsome Wench*. "When word got out that we'd bought a new boat, club members started sniffing around," Ruben laughed. "We always ran circles around everyone else in the *Wench* so it was an easy boat to sell." As for *Kismet*, they're getting her ready for some racing.





## — DIFF'RENT STROKES



**Ecstasy**, Defender 27 — As a wood and metal fabricator working on Treasure Island, Chad Castillo would watch sailboats glide by every day wishing he could be on one of his own. In October, he decided to make his own dream come true and he bought a little Islander Bahama 24. "The guy who sold it to me showed me how to sail for about an hour and then I was on my own," Chad recalls. "On my first sail to Angel Island, I ripped the sails."

Realizing that he had bigger dreams than simply sailing on the Bay, Chad upgraded to the Dutch-built Defender just a few months later. "I'm 99.9% sure the Dekker & Zoon boatyard is Laura Dekker's [the 14-year-old solo circumnavigator hopeful] family business," he claimed. We don't know about that, but we do know that *Ecstasy* is an interesting little boat that has the potential to take Chad wherever he wants to go — which just happens to be the Sea of Cortez.

"After the Sea, I'd like to make it down to San Blas," said Chad. "I've been to all these places by land, and now I want to do it by water. But I don't think I can right now because of Carla." Carla is Chad's 'better half' — a 12½-year-old pooch that is clearly the love of his life. "She doesn't mind gentle daysails but she hates it when things move around too much."

Hauled to check the status of his keel, *Ecstasy* revealed a little disconcerting electrolysis in the cast iron keel, and Chad was frustrated by the presence of about 378 million tiny gelcoat blisters. "I was thinking I'd let it dry out on the hard in Stockton this summer," he said with a distinct lack of enthusiasm. "But maybe I should just paint it and go sailing instead." That's what we like to hear, Chad!

"We've missed racing since we sold the *Wench*," Ruben explained. "It'll be very basic but a lot of fun."

Meanwhile, there's plenty to keep them busy on *Old Buffalo*. "She basically has a 'little old man's electrical system,'" chuckled Robbie. "If I want to turn on the propane system's solenoid, I have to flick on the aft cabin lights too!" But other than that, the most the boat needs is some upgrading and personalization. As far as Robbie is concerned, the immense foredeck — "We could play Frisbee on it!" — and separate shower stall more than make up for any minor repairs.

The Gabriels bought *Old Buffalo* — Robbie's late father's nickname — to fit their future cruising plans. Ask them today if they would have imagined such plans just a few years ago, and they'd laugh. But love at first sight is a funny thing. A longtime racer, Ruben was actually prepping his 22-ft Pearson Electra, *Sparky*, for the '06 Singlehanded TransPac when he locked eyes with the fetching beauty who was sanding the bottom of her Newport 30. A romance blossomed and when Ruben limped into Hanalei Bay 27 long days after the start of the race with a stump of a mast and a jury-rigged sail, Robbie was waiting for him. It was worth the wait — Ruben proposed during their stay on the island.



# BOATYARD TOUR

**Aparima**, custom 38-ft fir strip-planked cutter — It takes a certain kind of person to own a wood boat, and Carl Edwards is a shining example. "I like working with wood," he told us. Good thing, since that's also his profession. "I build sculptural furniture," he said modestly. When he showed us photos of his work, it was obvious that Carl is no mere woodworker — he's an artist. On retainer with two New York families to build custom pieces, Carl splits his time between the Big Apple and Marin's Rodeo Beach, the perfect location for this avid surfer.

But even though he's spent years in the water, Carl is relatively new to sailing. "This is technically my third boat," he explains, "but I sold the first one almost immediately after buying it because there



was too much work to do, so I don't really count it. My last boat was a Victory 21."

Since buying *Aparima* a year ago, Carl has spent countless hours working on her, including 40 days in the yard changing out the pintles and gudgeons,

chiseling the entire bottom, and removing and rebedding every single keel bolt. "It's been a learning curve here," he said, "and I've asked lots of questions." But in the end, he tapped into his own knowledge of wood to effect several stout improvements to the boat's structure.

Luckily for Carl, he's not in this alone. His uncle, Chris Corlett of Passage Yachts, knows a thing or two about sailing

and boats, and has helped him through the process of refurbishing this classic strip-planked beauty. "My uncle's sailed for a long time," noted Carl, "and he says he's ready to go somewhere. Wherever it is, it has to be someplace that I can bring my surfboards!"

## COASTAL

BATTERIES

**CUSTOM BATTERY  
CABLES & LUGS**

**MAGNUM**  
INVERTERS



The only AGM L-16  
400 AMP hour completely  
manufactured in the USA

NEW! 150 AMP  
hour group 30

- Serving all of Orange County
- Free Dockside Delivery
- Free Core Pickup
- Custom Battery Cables
- Fully Stocked Warehouse for Same Day Delivery
- Battery Service & Charging Available
- Will-Call Available



Crafted for  
quality in  
the U.S.A.

**Store Hours:  
8:00 am to 4:30 pm  
Monday thru Friday**

**COMPLETE LINE OF WET CELL  
BATTERIES AVAILABLE.**

distributor for  
**LIFELINE**<sup>®</sup>  
...the heart of your system<sup>®</sup>  
**PREMIUM AGM BATTERIES**

1725 Monrovia Ave., Unit B3 • Costa Mesa, CA 92627  
**Phone 949-722-1027 • Fax 949-722-8406**

# LOCH LOMOND MARINA

**Completely Rebuilt Marina • Gas & Diesel Fuel Dock • Free Pump Out Station  
Modern Launch Ramp • Guest Slips Available • Marine Mechanical Boat Repair  
Arena Marine Supply Store • Andy's Local Market • Bait Shop  
Land or Sea Canvas • Windjammer Yacht Sales • Loch Lomond Yacht Club**

**110 Loch Lomond Drive, San Rafael, CA 94901**

**Phone: (415) 454-7228 • Fax: (415) 454-6154**

**www.lochlomondmarina.com**

**Harbor Master – Pat Lopez • pat@lochlomondmarina.com**



*Watermakers Since 1987*

**SPARKLING FRESH WATER, POWER, AND REFRIGERATION FROM THE SEVEN SEAS**

110 VOLT / BELT DRIVE



AQUAMARINE



MODULAR KIT

HYDRAULIC



MYTGEN 150



12 VOLT DC

AQUAGEN 150



UPGRADE MOUNT

316 S/S REMOTE PANEL



AquaGen combines the quality, simplicity & reliability of AquaMarine, Inc. watermakers with the durability of the Kubota 150 amp 12V diesel generators. This compact low fuel consuming AquaGen is a powerhouse, capable of producing up to 150 amps, and 8 up to 62 GPH of fresh potable water from any water source. Make fresh water, refrigeration, and also charge your batteries all at the same time! A hydraulic pump may also be added to run your dive compressure, windless, bow thruster, or emergency bilge pump. Ideal for longterm cruisers or weekend wanderers. We custom engineer our systems to fit any size vessel or cabin site. Electric, Hydraulic, or Belt Driven Modular Kits are also available. Visit our Website for more information.

QUALITY AT AFFORDABLE PRICES.

LIFETIME WARRANTY ON PUMP HEAD AND PRESSURE VESSELS.

AquaMarine, Inc., 58 Fawn Lane (P.O. Box 55) Deer Harbor, WA 98243 USA  
(800)or(360) 376-3091 Fax (360) 376-3243

[www.aquamarineinc.net](http://www.aquamarineinc.net)



**MARINE INSURANCE SPECIALISTS**

*Your best source for Yacht and Boat Insurance tailored to your needs and competitively priced*

**We Insure:**

Sail or Power ♦ Classic or Contemporary  
Fiberglass ♦ Aluminum ♦ Steel ♦ Wood

At Heritage Marine Insurance you will find knowledgeable insurance professionals who provide the best service and the finest coverage available today.

*Please contact us for a quote*

[www.heritagemarineinsurance.com](http://www.heritagemarineinsurance.com)

**800-959-3047**

Fax 860-572-5919

Email: [classics@heritagemarineinsurance.com](mailto:classics@heritagemarineinsurance.com)

# PACIFIC CUP

The entry deadline has passed for the 16th biennial Pacific Cup, and the final tally is 56 boats — pretty phenomenal given the current economic climate. Split up among seven divisions, the fleet comprises many of the West Coast's most active race boats, which should lead to some close corrected-time deltas and hard-fought battles on the North Pacific over the 2,070-mile slide from San Francisco Bay to the beautiful — and extremely hospitable — Kaneohe YC. The starts are spread out over a very media-unfriendly six days, but everyone should get to Hawaii in a pretty tight group. As is our custom, we preview the race here, anointing eight boats with the customary "Latitude jinx." Bear in mind that with the starts spread over so many days, picking an overall corrected-time winner is a crapshoot at best, but we'll throw it in anyway just for kicks. Keep this guide handy and evaluate our performance while following the race at [www.pacificcup.org](http://www.pacificcup.org).

## Start Day: Monday, July 5

*Doublehanded 1* — This six-boat division includes a couple of returning boats — Paul Disario and Tony Porche's Olson 911 *Plus Sixteen*, and Dylan Benjamin and Rufus Sjoberg's Dogpatch 26 *Moonshine* — and more than a couple of returning Pac Cuppers as well. Although *Moonshine* previously won the race overall, it's tough to bet against a well-prepared Cal 40 in a Hawaii race, and that's exactly what husband and wife Rowena Carlson and Robb Walker are bringing to the table in *Nozomi*. Walker formerly worked as a designer in the Nelson Marek Design office and, unless he's forgotten a thing or two since leaving, should be pretty tough against the rest of the division.

Our pick: *Nozomi*

*Division A* — This ten-boat division also has a few returning boats from previous races, and it should be a closely-contested division between the third-slowest, and third-fastest rated boats — YRA President Pat Broderick's Wyliecat 30 *Nancy*, and Mary Lovely and Jim Quanci's Cal 40 *Green Buffalo*. Broderick has enlisted the help of Alameda sailor and multiple Santana 22 national champion Michael Andrews, and one of the Bay's most accomplished racers in everything from El Toros to his modernized Santana 27 *Arcadia*, Gordie Nash. The trio should prove tough especially if the race is reachy, where the cat-rigged boat should excel. Their biggest challenge will likely be figuring out what to

do with all their free time — Wyliecats have all of four strings to pull, if you include the halyard. But *Green Buffalo* has been on a really hot streak of late, with Quanci winning the singlehanded and crewed Farallones Races overall in the last couple months. There's no substitute for waterline in a lot of conditions, and as we said, it's tough to bet against a well-prepared Cal 40 in a Hawaii race.

Our pick: *Green Buffalo*

## Start Day: Tuesday July 6

*Doublehanded 2* — This could be the toughest of any of the divisions. First, you have Rachel Fogel and JP Sirey in Fogel's Express 27 *Great White*, which she's been preparing for the race since last spring. Sirey is a veteran of multiple Hawaii races, and together, they could prove to be pretty tough. Also in

an Express 27 is Steve Carroll, who will be sailing his *Tule Fog* with Santa Cruz Sails' Patrick Lewis. The duo won their division in last year's Coastal Cup and should prove extremely tough. A pair of Minis — one a hopped-up prototype boat and the other a stock series boat — could prove to bat well above their diminutive LOA: Taylor Cuevas's series Zero *Poco Loco*, with Dave Maggart aboard, could prove troublesome for Emma Creighton's Simon Rogers-designed prototype *Pocket Rocket* due to the seemingly large rating spread. In the Mini Transat race, well-sailed series boats have routinely finished in the top ten overall, very close to their turbocharged bretheren which sport movable ballast, more sail area,

**Will the sky be the 'Limit' for Australian Alan Brierty's R/P 63? If it goes, one of this year's two scratch boats could do really well.**



ERIK SIMONSON/WWW.H2OSHOTS.COM

and less displacement. Creighton has an ace up her sleeve in co-skipper Andy Hamilton, who won his division in '08 with his Moore 24. While all of these boats represent legitimate threats, there's another that we'd have to say looks pretty damn good. More than one pro we've talked to over the years has identified the Farr 30 as their boat of choice to race to Hawaii if they could afford to not get paid to do it on someone else's. Multiple Hawaii race veterans Skip and Jody McCormack should get theirs, the Tiburon-based *Trunk Monkey*, to Kaneohe Bay pretty fast. The pair has put a tremendous amount of preparation into the boat since acquiring it early last year, adding a transfer-sprit while fairing the bottom, and proved their mettle in this year's windy Spinnaker Cup.

Our pick: *Trunk Monkey*.



**Division B** — There are plenty of strong entries in Division B and no fewer than four returning boats from '08 in this nine-boat group. The scratch boat is John Mendoza's Bénéteau 46 *Pneuma*, which in a waterline battle could hang with Peter Heiberg's Palmer Johnson 49 *Scar-amouche V*. Greg Paxton and Arnold Zippel could be tough aboard their Sydney 32 *Relentless*. But '08 division runner-up Dean Treadway and his well-traveled Farr 36 will be hard to top. His beautiful, bright-finished, cold molded *Sweet Okole* won the TransPac overall in '81. Santa Cruz Sails' David Hodges is on the roster and this should be the boat to beat.

Our pick: *Sweet Okole*

#### Start Day: Wednesday, July 7

**Division C** — With everything from a Columbia 30 Sport to a Swan 59 at each end of the length and rating spectra, this nine-boat division is a tougher call. The only division starting on Wednesday, this one could see Antonio Luttmann's Mexico-based Swan 59 *Andromeda* live up to her billing as the scratch boat in a waterline race, while a breezy, downwind race could see James and Chris Gilmore's Columbia 30 Sport *Uncontrollable Urge* put their rating to good use. In the middle, Bob Gardiner's Olson 40 *Spellbound* could threaten as a compromise between the extremes. However, there are two Synergy 1000s — Joshua Grass's *Summer Moon* and Dave Rasmussen's *Sapphire*. The Carl Schumacher design has proved to be pretty devastating on this course. In the '08 race, Rasmussen was a division runner-up with returning crewmember Phil Krasner, and the two will be joined this year by multiple Wylie Wabbit season champion Colin Moore. Grass is bringing top talent with him also, in the form of Moore 24 and Snipe sailor Bart Hackworth, plus the owner of the T650 *Flight Risk* Ben Landon, and Wabbit sailor Ron Tostenson. There should be a pitched battle between the two boats.

Our pick: *Summer Moon*

#### Start Day: Thursday, July 8

**Division D** — The second-lowest-rated division boasts an interesting mix of boats that range from 36 to 56 feet in



DENNIS HUETTE

**Pat Broderick will be sailing his Wyliecat 30 'Nancy' this year, and is a veritable threat with crew Michael Andrews and Gordie Nash.**

length. At the shorter end of the spectrum is Mark Howe's Farr 36 ODR *War Pony*, navigated by the Bay's Will Paxton and featuring rigger Gilles Combrisson in addition to Cyril Guiraud and Howe's son Ross. After a pretty intensive work-up over the past nine months, *War Pony's* riders should be pretty well-prepared for the rest of the division. However, their punitive rating won't do them any favors against the division's SC 50s, which include Wayne Zittel's turboed *J/World's Hula Girl* — which Paul Cayard sailed to third in division in the '08 race — and Bill Helvestine's *Deception*, which despite being the only of the three boats to have a carbon deck, is the highest-rated. Right in the middle is Jack Taylor's Dana Point-based *Horizon*, which in addition to winning its division in last year's TransPac and this year's PV Race, features many of the returning crew from those efforts, including an impressive father/son combo in navigator Jon and watch captain Erik, Shampain. Buzz Blackett's new Jim Antrim-designed Class 40 *California Condor* is still signed up to race, but at this point we'd be (pleasantly) really surprised if she flies in this one. At last check, she was on the hard still and has yet to be properly shaken down. But if *California Condor* makes it to the starting line, you'd better bet that Blackett, his son David, Antrim, Liz Baylis and husband Todd Hedin, plus Tom Paulling will get the powered-up reaching machine there in short order. This one's tough to call, but just like a Cal 40 is tough to bet against in a Hawaii race, so is a SC 50.

Our pick: *Horizon*

# PACIFIC CUP

## Start Day: Saturday, July 10

**Division E** — Just what you've been waiting for, the really big boats! Unfortunately this year's big boat division is smaller than in past years, but it has some quality entries to make up for the lack of numbers. The fleet has not one but two scratch boats in Philippe Kahn's turboed Owen Clarke-designed Open 50 *Pegasus OP-50*, and Australian Alan Brierty's R/P 63 *Limit* — although we'd heard rumblings that the latter may not be going. For the last three Hawaii races, Kahn has sailed his boat doublehanded, but this year he's taking Volvo Race veteran Mark Christensen and David Giles, plus one of the most experienced West Coast offshore sailors, Zan Drejes. While *Pegasus* is designed to be efficiently shorthanded, with a crew of four, she should be able to be pushed to her absolute potential. *Limit* should be extremely quick as well, and would do quite well if it's a lighter-air race and the decidedly stickier *Pegasus* can't get fully powered-up. The division thankfully features a SC 70 — which should be mandatory for any Hawaii



**Skip and Jody McCormack's Farr 30 'Trunk Monkey' is our pick for the boat to beat in DH 2.**

race, although we're a bit bummed not to see more of them — Hector Velarde's Miraflores, Peru-based *Mirage*. Also in the mix will be Jim Partridge's largely-untested Antrim 49 *Rapid Transit*, which was finished last year by Berkeley Marine Center and could prove to be a wild card. But if we had to make the call for a winner it would come down to two boats:

Canadian Ashley Wolfe's Bay Area-based TP 52 *Mayhem* and Chip Megeath's Tiburon-based R/P 45 *Criminal Mischief*. Volvo Race veteran Richard Clarke will be navigating *Mayhem's* mixed Canadian and American crew which includes Bay Area pro sailors Nate Campbell and Jeff Causey. But *Mayhem's* competition will likely be a boat with division wins in pretty much every distance race of consequence on the West Coast since '08, including the '08 Pac Cup. Megeath's team aboard *Criminal Mischief* includes one of Northern California's most experienced offshore sailors in Monterey's Robin Jeffers, plus navigator Jeff Thorpe, who has been with Megeath since he chartered Lani Spund's SC 52T *Kokopelli*<sup>2</sup> for the '07 TransPac. Add in young but extremely experienced guys like Joe Penrod and Pat Whitmarsh, who have many an hour on an 18-ft skiff, and you get the idea: these guys will be tough.

Our pick: *Criminal Mischief*

Elapsed-time pick: *Pegasus OP-50*

Overall pick: *Criminal Mischief*

— **latitude**/rg



## PASHA HAWAII

Scheduled service  
from the Mainland  
to Honolulu, Kahului  
and Hilo

And no matter where  
home is, we can provide  
Transportation  
Logistics for smooth  
sailing.

Customer Service:  
866.393.9831

## TAKE THE EASY WAY HOME . . .



PASHAHAWAII.COM

# THE FREEDOM OF WIRELESS

Wind speed: 24 knots  
 TBS: 8.4 knots  
 True wind angle: 32°  
 Wires: zero



## WIRELESS INSTRUMENTS FOR RACING



Tacktick by Suunto's extensive range of wireless, solar-powered marine instruments provides critical information about your racing boat and its surroundings.

[www.tacktick.com](http://www.tacktick.com)

Simple to use and easy to fit, the modular Tacktick display units provide all the race data you'll ever need. The use of superior Micronet wireless technology also enables complete reliability and confidence in your performance.

With the addition of Suunto precision instruments, you can make informed split-second decisions in any race.

To find out more, or to test a configuration on your boat, visit our website.

**tacktick**  
 WIRELESS  
 by SUUNTO



**STILL GUESSING?**

**Complete Battery Monitoring System**

from **\$154<sup>00</sup>** *Dealer Inquiries Welcome*

**SWEDISH MARINE**

1150 Brickyard Cove Rd., #B6, Pt. Richmond, CA 94801  
 (510) 234-9566 • [info@swedishmarine.com](mailto:info@swedishmarine.com)

# HANSEN RIGGING



**...FAST**  
 Congratulations to  
 Double Trouble  
 1st Overall  
 Spinnaker Cup

## MAST SHOP

Rig safety and performance are critical to successful ocean racing and voyaging. Call us for all your rigging repairs & improvements.

[www.hansenrigging.com](http://www.hansenrigging.com)

Showroom: 2307 Blanding Ave., Alameda  
 (by the Park Street Bridge)



**(510) 521-7027**



# LEE HELM

It, like, happened again. Max gets to navigate to Hawaii, and I end up stuck here answering his newbie questions about weather via email. I don't even get the T-shirt. Totally unfair.

So the night before the start, I get this frantic email: "Lee, I need you to tell me everything you know about squalls." And then he dredges up this old mnemonic artifact:

"First the rain and then the wind,  
Tops'l sheets and halyards mind.  
First the wind and then the rain,  
Hoist your tops'ls up again."

Gak! I mean, like, call the rhyme police on that puppy.

I typed back: "Is that all you know about nocturnal mesoscale convective systems collapsing during tropospheric cooling?"

And he answered, "The write-up in the race guide says to always 'exit stage left.' And it says that squalls usually sail on starboard tack, whatever that means. And there's something about jibbing back into the squall when you're headed, which seems all wrong. Can you make

thick skull. I reminded him that I know his charge number at the yacht club.

"A round of drinks for you and all your windsurfer friends," he offered.

I decided to wait a few minutes while I got back to work on some towing tank data I was analyzing.

"Okay, Lee," he promised in his next email. "Dinner for you and all your windsurfer friends, if we win our division."

"In the top three," I counter-offered. "And make it a lobster feed." Max always starts his negotiations from a weak position.

"It's a deal," he finally answered. So I typed up the basics, careful not to go too fast and drain what cognitive surplus he might have at this late hour:

"First we need to discuss the vertical stability of air. Air gets colder when it expands. It gets warmer when it's compressed. Air expands when it goes up, and air compresses when it goes down. If you don't give it enough time for any heat energy to go in or out, the change in temperature of a piece of air as it goes up or down is called the adiabatic lapse rate.

It's 9.8°C per kilometer, or about 5° per 1,000 feet. So if you raise a chunk of air 1,000 meters, it gets 9.8°C colder. If you move it down 1,000 meters, it gets 9.8°C warmer, due solely to the change in pressure. For dry air, that is.

"Now consider the temperature profile of the air. Imagine sending up a balloon that continually transmits the air temperature as it

goes up. You get a vertical profile of the environmental air temperature. The slope of this temperature profile determines if the air mass will be stable or unstable. For 10 points: Which is unstable? An environmental temperature profile steeper or shallower than the adiabatic lapse rate?"

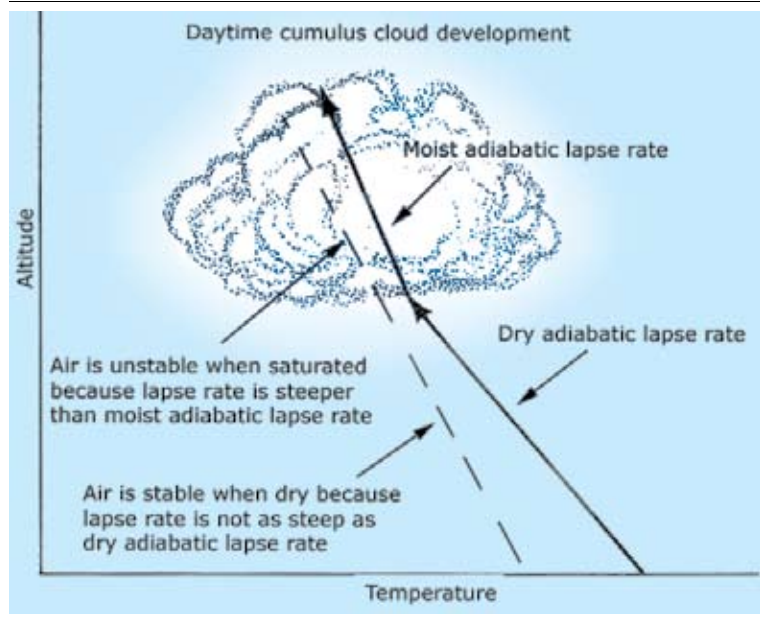

**At low altitude, the lapse rate of the environmental temperature profile is not as steep as the dry adiabatic lapse rate, so the air is stable. Above the cloud base, the air is saturated and moist adiabatic lapse rate applies, so the air in the clouds is unstable and they develop vertically.**

sense out of this for me? They made me navigator on this boat, and I really want to look like I know what I'm doing when the squalls start."

"For sure, Max, but it'll cost you," I replied. I had a project due and really didn't want to spend all night trying to pound basic meteorology into Max's



I figured that would hold him for a few minutes while I got back to work.

About 20 minutes later my mail client signaled more incoming.

"A steeper environmental temperature gradient means unstable, right? Because when the air moves up, it cools, but not as much as the air around it, so it ends up warmer and more buoyant than the air around it, and it keeps floating up. Like a lava lamp, right?"

"Ten points!" I answered, although I don't have a clue what a lava lamp is. Then I added in the effects of water evaporation and condensation, just to make it more interesting.

"So far we just looked at the dry adiabatic lapse rate. If there is moisture in the air, the temperature change as air moves up or down can be drastically reduced.

"Consider air that's near 100% humidity (like air near the surface in the trades). If it moves up very far, the capacity of the air to hold water vapor is reduced, so the water vapor condenses into water droplets. You have a cloud.





*Sailing into a squall can be intimidating but understanding squalls is the key to using them to your advantage.*

and you have a cold blast of more wind. Behind the squall, the downrush wind subtracts from the average wind, and you have a calm area.

"But then it gets more complicated. The upper air is moving in a direction maybe 15° to the right of the wind at the surface. Why is that, I hear you ask? Coriolis acceleration. Air tries to flow from high pressure to low pressure, but in the northern hemisphere it gets spun off to the right. Actually the air is just trying to go straight, but the earth keeps spinning underneath it. Consider a high pressure system. Air wants to go from high pressure to low pressure, but which way does it end up turning?"

This was so not a complicated enough question to keep Max busy for very long. He already knew that air flows clockwise as it flows out from a high and counterclockwise as it spins into a low, but he didn't seem to really understand why.

"Here's an experiment you can do right now in your car," I typed. "Adjust the air conditioner vent so the jet of air just hits your right ear. Turn the fan on full power. Now drive straight ahead at low speed, then make a sharp left turn. This simulates the rotation of the earth in the northern hemisphere. Drive at the speed that lets you make the fastest rate of turn. It's the rate of turn that counts, not the forward speed. Tell me what happens."

This gave me another 45 minutes to do some useful work, even more than I had anticipated, before Max reported back.

"**H**ey, that's amazing! When I made a sharp left turn, the air was hitting me right in the face! And I went to the all-night market and picked up some extra beef jerky for night watch snacks, too."

"Very good. In the rotating reference frame of your car, the air seemed to flow in a curve. What does this have to do with squalls? The wind aloft tends to be diverted so much by Coriolis that it follows the

isobars around the highs and lows. But on the surface it's slowed down by friction, so the pressure gradient has a relatively larger effect, and the wind direction will be skewed more from high pressure to low pressure. The result is that the wind direction aloft is usually to the right, or rotated clockwise, relative to

But that process keeps the air warm, releasing the heat of condensation of the water. If the air is prevented from cooling by moisture condensing out as it goes up, then it's even warmer in relation to the cold air around it. That is, the moist adiabatic lapse rate is less — typically only 6°C per kilometer. So it's even more unstable than if it had been dry air. It rises faster, more water condenses, it goes up even faster, and you have a towering cumulous cloud. This happens all afternoon and into the evening in the tropics, after the sun heats up the water surface and the lower levels of air warm up and pick up moisture.

"For 20 points, can you describe what happens if air containing water in liquid droplets — that is, air in a cloud — starts to go down?"

I was sure this one would give me at least, like, another 20 minutes for some useful work, and I was right.

"**O**kay, I got it!" he typed back after half an hour. "If the air is going down, the pressure and temperature increase, so the air can absorb more water in vapor

form, so the droplets evaporate and keep the air cool. Evaporation cools. So the air is also very unstable going down."

"You looked that up, didn't you?" I challenged. "Or did you actually remember that evaporation cools things down? Never mind, you see how moisture enhances instability. It's why we get a stronger sea breeze on the Bay when we have higher humidity inland, and less sea breeze in a dry air mass. And now we totally have the basic growth and collapse structure of an isolated thermal cell: The towering cumulus cloud that was building all afternoon and all evening when the sea surface was warmed by the sun, now starts to cool off and when the air starts to sink again, the moisture keeps it cold even as the pressure increases, so it collapses fast.

"That's your basic convective trade winds squall. The squall wind is from the very powerful downrush of air out of the collapsing cell. It hits the surface and fans out. In front of the squall, the downrush wind adds to the average wind

*Max always starts his negotiations from a weak position.*

MICHAEL HALMINSKI / NOAA

# LEE HELM

the surface wind direction. Squalls move with the upper air, so if you're sailing in the surface wind, it looks as though the squalls are moving on a starboard tack broad reach.

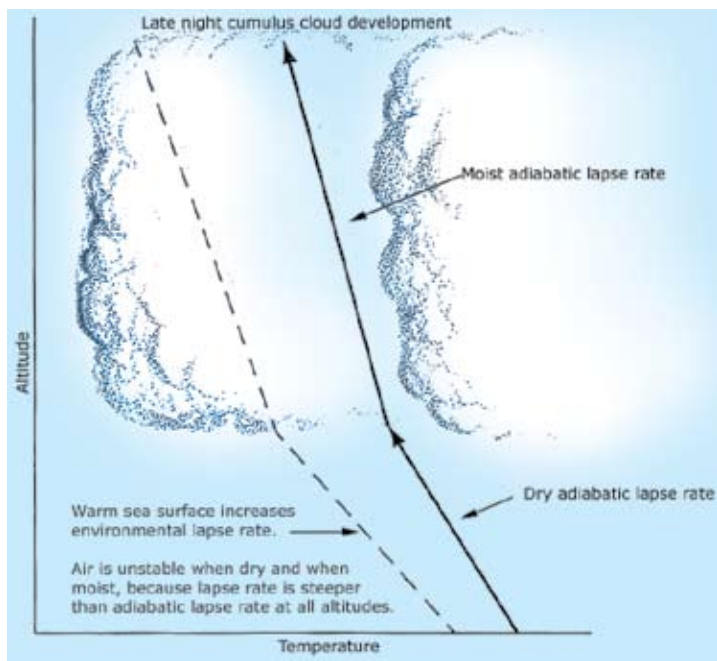

**Late at night, air near the surface is unstable, allowing new updrafts to form ahead of the squall gusts from the downrush core. This could explain why "First the rain and then the wind" usually means strong squall winds follow.**

"That's why, when you leave a squall and want to get away from the calm area behind it, you 'exit stage left.' To generalize, sailing on port tack gets you into or out of the squalls faster. Sailing on starboard tack keeps you in the same conditions longer. For a change, port tack. For status quo, starboard tack.

"But also, since the downrush air comes from upstairs, there's likely to be a clockwise shift in the squall wind. If you're on starboard sailing downwind polars, suddenly you're lifted way up and you really want to jibe right then, because if you can get onto port pole you could sail very fast right toward the finish line instead of 45° off course. Unless the squall is, like, a lefty."

"I think I'm with you so far," Max typed back. "We have a two-pole jibe system so we'll be able to respond pretty quick to wind shifts in squalls. Not like last time, when it took so long to get all hands up on deck for a heavy-air jibe that by the time we jibed the shift was over, then we had to get everyone up again to jibe back, and after a few nights of this, the navigator was afraid to call for jibes at night because no one was getting any sleep and they were going to keelhaul him. But what about my rain and wind

rhyme?"

"This is where it gets even more interesting," I wrote. "So far we've been considering one isolated convection cell. Air goes up during the day and evening, air falls back down late at night.

"But first, more about vertical stability. It's not unusual for dry air to be stable and saturated air to be unstable, especially during the day. So the instability starts at the cloud base altitude, where the humidity is at 100% and the moist adiabatic lapse rate is less than the environmental lapse rate, so the air bubbles up, forming the cumulus cloud.

At the top of the cloud most of the moisture is gone and the adiabatic lapse rate is closer to the dry lapse rate, so the air becomes stable again. You can often feel this from an airplane descending through a cloud layer. It's bumpy in the clouds, but not above or below.

"At night, when the air near the surface is kept warmer than the air above it by the heat retained in the ocean, the instability can reach all the way down to the surface, so it's easy for a disturbance, like the cold downrush wind from a collapsing thermal cell, to wedge under the warm surface air and touch off another cell of rising air.

"It's totally like a multi-cylinder piston engine — one piston going down and the one right in front of it going up — and the strongest wind is between the two.

"Now think of the implications for the surface wind pattern. It's not just an outward-flowing radial pattern under the downrush core. It's a dipole. Outward-flowing around the downrush column,

inward-flowing under the new updraft created ahead of the downrush. Like a source-sink combo in computational fluid dynamics.

I knew this would sail over Max's head, but it was too geeky a reference to pass up.

"Lee, are you ever going to tell me if you think that old rhyme is valid?"

"Explanation of the ditty:" I answered. "If there's a strong updraft ahead of the main squall, you'll have reduced wind and rain, as the moist air rising in the upstroke piston ahead of the main downrush column condenses out. The real blast will follow. Hence, 'first the rain' means you're about to be hit with strong wind.

"If there is no initial rain, then you're already in the worst of it. That's the 'first the wind' part. Even if there's rain after the wind, which there often is, you can reset your tops'l, which I guess was sort of the same as a spinnaker 200 years ago."

"But why does Stan Honey say that if you're on a fast sled and you can jibe back and forth across the face of a squall, you'll get headed just before you get to the edge of it?"

"That's also explained by the dipole shape of the surface wind. On the squall boundary, the wind is curving back in toward the suction of the updraft ahead of the squall. Your next assignment is to

## Squally Rules of Thumb

- Squalls sail on starboard tack
- Squall wind is usually right-shifted — be prepared to jibe to port
- But sometimes the squalls are left-handed
- Exit stage left to avoid light air behind the squall
- Each squall will be stronger than the previous squall that night
- Avoid squalls at sunrise
- If the boat is fast enough to stay with a squall, look for a header when it's time to jibe
- Even late at night, some columns of clouds are rising, not sinking

draw a diagram of this and get back to me."

This bought me another half hour until the next email from Max. No text this time; just an attachment that turned out to be a scan of his diagram of surface winds. It wasn't too bad, for a concept sketch.

"Ten more points," I replied. "The big challenge in squall strategy is figuring out which part of the squall is going up and which part is going down, and how many of each kind of cell you are dealing with. To stay with the multi-cylinder metaphor, are you dealing with a straight six or a V-8?"

"Radar helps. It shows you where the rain is, and makes it easier to intercept the most powerful squalls. Radar and two-pole jibes, and a power budget that lets you run the radar all night, are your friends. Are you going to be a watch-stander, Max?"

"That's the best part," he bragged. "I'm a floater, no watch schedule, so I can get all the weather maps. I'm looking forward to getting some sleep on this trip."

"Not when you're in squall territory," I warned him. "You need to be on-call

from 2-8 a.m. PDT every night. That's when all the action happens, and that's

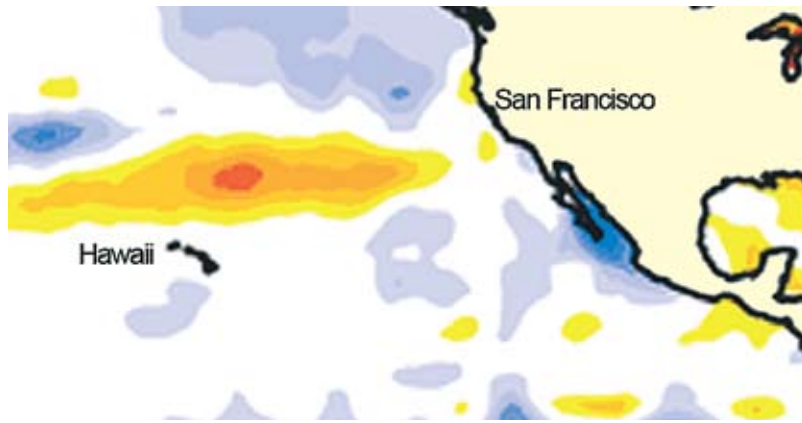

Sea surface temperature anomaly as of mid-June. Sea temps for the last half of the course are normal, suggesting average squall activity.

when they need the squall tactics to be worked out. Wait one sec while I check the sea surface anomaly."

A quick look at [www.esrl.noaa.gov/psd/map/images/sst/sst.anom.gif](http://www.esrl.noaa.gov/psd/map/images/sst/sst.anom.gif) told me that the fleet would sail through

a warm region early in the race, but late in the race the sea surface would be close to average, suggesting only an average level of squall frequency and intensity. Possibly less than average, if the wind brought relatively warmer air over the relatively cooler ocean for the second half of the race. I relayed my prediction to Max.

"Good to know," he replied. "Red sky at night, sailor's delight."

"Red scarf in morning, sailors take warning," I reminded him. "But like, that's for after the finish. Good luck! Me and my buds will see you at the lobster feed when you're back on this side of the pond."

— lee helm

**Celebrate the Boating Lifestyle!**



Discover

Brisbane Marina



From Hwy 101, take the Sierra Point Pkwy exit and follow the signs to the marina.

400 Sierra Point Parkway  
Brisbane, CA 94005

(650) 583-6975

[www.ci.brisbane.ca.us](http://www.ci.brisbane.ca.us)  
[harbormaster@ci.brisbane.ca.us](mailto:harbormaster@ci.brisbane.ca.us)

**GREAT LOCATION!** Just minutes to Central Bay sailing.

**GREAT RATES!** Starting at \$5.90/foot!

**MARINA GREEN** with picnic/BBQ areas, Bay Trail Access and FREE Wi-Fi.

**HOME OF THE SIERRA POINT YACHT CLUB**



# THE RACING

We'd planned on having a lot more variety covering last month's big events. But right before we went to press, one of the most epic **Coastal Cups** in recent memory got some of our contributors so fired up that by the time we got their stories in here, we'd pretty much run out of room for anything else. We did manage to work the **Spinnaker Cup** in here and the **International Canoe North Americans** as well. We follow it all up with a few **Race Notes**. Our apologies to everyone who went to the effort to send us something about their regatta, we'll try to get you next month, and in the meantime, Enjoy!

## Coastal Cup

The word "epic" has become so misused of late there's even a Facebook page dedicated to those whom it annoys. But if ever there was a race that deserved the moniker, it was the Encinal YC's Coastal Cup, which started in the Bay June 16.

The 277-mile run down the coast to Santa Barbara had everything it promises prospective entrants — big breeze, big waves and short elapsed times.

How breezy was it? Most of the boats reported wind up to 40 knots during the trip, meaning

that it was a clip-in, hold-on, don't-let-the-lifejacket-inflate type of race. Australian Alan Brierty's R/P 63 *Limit* — the scratch boat in the race — finished in just 22h, 13m. That's less than two hours off the elapsed-time record set by Doug Baker's *Magnitude 80* in '06 at 20h, 54m, 30s. *Limit*'s effort wasn't too far off when you consider that she gives up 17-ft of waterline to *Mags*, and is conventionally ballasted rather than canting-keeled.

With the bulk of Fleet A already finished and Andy Costello's Pt. Richmond-based J/125 *Double Trouble* looking to be the overall winner, Charles James' and Jon "Chewie" — as in everyone's favorite *Star Wars* wookiee — Stewart's Mancebo

**Andy Costello's J/125 'Double Trouble' blasts out the Gate on the way to a win in Fleet A.**

31 *Bloom County* snuck into Santa Barbara Friday evening just before sundown to take the overall honors by a little over 16 minutes. The powerful little Sausalito-based, Bay Area-born-and-bred ULDB, designed and built by Dave Mancebo in the mid-80s, finished within an hour and a half of John Grey's Pt. Richmond-based Farr 30 *Cal Maritime* on elapsed time. Stewart and James were joined by Nate Ballard, Keith "Panda" Love, and James' son Elliott.

There was plenty of carnage, as you might imagine. Per Peterson's Oceanside-based Andrews 68 *Alchemy* sailed the last half of the race without a headfoil after incinerating it in a wipeout. Peter Blackmore's Oyster 49 *Pied Piper* was dismasted, safely making port in Monterey.

*Cal Maritime* ended up third overall behind *Double Trouble*. Fourth went to Greg Nelsen and Kevin Flanigan's Alameda-based Fox 44 *Ocelot*, which in turn battled the whole race with *Double Trouble*. Add in Dave Van Houten's Tiburon-based Thompson 38 *Serena* in fifth overall, and you get an all-Bay Area top five!

What follows are two stories from the race that show just how nuts it was out there:

### Bloom County — Mancebo 31 Charles James & Jon Stewart

Turn left! Left! No time for anything but to grab the helmsman's shoulder and yank. A white bulbous head careened down the side of the boat at 12 knots.

"What was thaaat?" Elliott shouted. What are the chances of sailing 90 miles from San Francisco and having a "head-on" collision with a dead, nine-foot long,

four-hundred pound Risso's dolphin? Apparently pretty good.

It was the Coastal Cup, and was blowing 20-plus knots. We were jammin' down waves with the big kite up, and it was a gorgeous afternoon — just what the brochure said it would be. Five o'clock happy hour: time for Pink Drinks. A Pink Drink is a Charles James concoction of vodka, Simply Limeade, squeezed orange juice, and pomegranate juice. It's basically adult Kool Aid and quite refreshing.

COURTESY BLOOM COUNTY



**'Bloom County's Charles James and Jon Stewart.**

ERIK SIMONSON/WWW.H2OSHOTS.COM



ERIK SIMONSON/WWW.H2OSHOTS.COM

"Whale off the starboard bow!" A spout sent a geyser shooting up 100 yards away at one o'clock off the starboard bow. "Look for more; look for babies. . . ."

Two spouts later a big old humpback surfaced off our starboard beam. We got to see half his head, the crown around his blowhole, and his back, all up close and personal. What a beauty. Now off our quarter, he gave us one more look; his massive tail rising out of the water before going vertical and slipping into the depths. The whale trackers would have loved that shot.

At 6:30 p.m. it was time for a pre-made pasta dinner. But the waves were getting bigger and the wind was building with them. We had to make an assessment between then and nightfall. We had to get the boat put away and the crew fed and geared up for night fighting. The crew voted that it wasn't worth the time and effort to heat up the pasta, so we ate it cold and it was still darn good.

Around 8 p.m. we saw more whale spouts off in the distance. Thank God, if things truly do come in threes, then we'd gotten the whales out of our system. A decade earlier, sailing a Henderson SR



**'Prevail', 'Alchemy' and 'Bad Pak' beat off the City-front. Inset, Kevin Flanigan's Fox 44 'Ocelot' was locked in an intense battle with 'Double Trouble'.**

33 in the Coastal Cup, we'd had a close encounter of the whale kind.

Back then, we were carving down deep in a particularly juicy wave at 2 a.m. As we reached the bottom, a whale stuck its head out in front of our bow.

*Oh sh#!* We turned hard left, it lunged hard right, pivoted, and tomahawked its flipper six feet over our heads and down the side of the boat, petted a girl sitting in the stern pulpit, and stole our speaker.

Fast forward ten years, and by 10 p.m. we'd been lifted by the 30-knot breeze and got all hands on deck after deciding to gybe to sail a potentially shorter course down the coast. We picked a wave and started the maneuver. It turned out like the first pancake in the batch — not very good. We made the turn, botched the sheet rotation and saved it once. WHAM!

We rounded down and worked on getting weight on the high side, getting the vang released, and dropping the kite, before gybing back and re-setting the kite.

That got our attention. We'd been sailing flawlessly up to that point. A little while later someone noticed a spreader-poke in the main that must have happened during the round-down.

We sailed for awhile until we found lighter breeze — 25 knots — and gybed back. We knew the main wouldn't hold all the way to Santa Barbara. One of our bowmen, Keith Love — who's not a porn star, but rather a surly midget some of you may know as "Panda" — volunteered to go aloft and tape it. We bumped him to the second spreaders where he spent the next 10 minutes taping up the tear on both sides of the main. He definitely gets the "cojones" award for that, because while we'd adjusted our angles to throttle back and make the boat sail as smoothly as possible, *Bloom County* is still a 30' ultralight. We were still hurtling down the waves, and flicked him around pretty good a couple times.

At midnight, I awoke to the boat doing the "driver-getting-tired" rolls. At this point I'd netted 40 minutes of sleep —

in full gear in case something happened — on a two hour off-watch. Listening to the boat's sounds, it was apparent she was hauling a\$\$\$. Four minutes later I got the call.

"Chewie!"

I came up on deck and it was pitch black. Someone had turned out the lights. There'd been a sliver of a moon when I'd gone below to "the land of mini me" — *Bloom County* is a flush-decked ULDB and has very little interior. Nate, Charles and Elliot had seen these clouds ripping past the moon and decided, "let's go over there."

They'd found the *big breeze* in a cloud entity. It was blowing 30-plus knots and we still had the big kite up. I acclimated and took the helm, impressed that Nate had been driving in this stuff — but you can't tell him that because his head is too big already. The boat was ripping off boatspeeds in the sustained high teens, but it was jittery, and the options on where you could put it were getting limited. You *must* to be able to put it where you want to, because you can't see f#!&-all. It was haunted house-dark. The closest I can describe it is the sensation you get when you harness into a roller coaster and it accelerates down a pitch black, twisting, winding tunnel. Only this tunnel was four hours long. We were far offshore, and given that you have to be able to finish a race to win it, we switched to the fractional kite.

Good move.

We were still hitting speeds in the high teens, but could all of a sudden put *Bloom County* where we needed to. While the boat is a little undercanvassed by modern standards, she's perfect in that type of stuff.

At 1 a.m. my neck and shoulders were tight and my right buttock burning from point loading for an hour on the corner of the cockpit — the most effective steering position. I asked Panda to flip out the little cockpit seat but the runner was blocking it. I attempted to stand up and drive as I

**'Bloom County' in this year's Vallejo Race.**



# THE RACING

LATITUDE/ROB



LATITUDE/ROB



LATITUDE/ROB



LATITUDE/ROB



LATITUDE/ROB



**Clockwise from bottom left — Dean Hocking's 'Ohana' on the Way back from Drake's Bay June 8; David Britt's Beneteau 10R 'Split Water' wads it up near Kirby Cove en route to a second in PHRO 2 for the return leg; Peter Molnar's J/105 'Poseidon's' chases Nat Criou and Nathan Bossett's Express 27 'Elise' along the Headlands, results are at [www.yra.org](http://www.yra.org); next three photos — on the Cityfront that same weekend, the St. Francis YC hosted the Woodies Invitational, results at [www.stfyc.org](http://www.stfyc.org); Steve Waterloo's 'Shaman' won her division in the Spinnaker Cup for the sixth time in seven years; Doug Kirk, Brendan Busch, Hogan Beattie, Bill Turpin and Bob McIntire enjoy a nice ride down the coast; 'Double Trouble' and 'Criminal Mischief', 1-2 overall in the Spin Cup; rippin' downwind on 'Akela.'**

had earlier in the day.

Wrong!

I ended up pulling the boat right down into a round down. Panda and I were on the low side doing the "dead ant." I saw the kite off to my right do two big thwacks and heard a loud pop. "Damn, there goes the kite," I thought to myself. I pumped the tiller skyward. Miraculously, the

rudder caught and the boat pivoted and gybed back, assisted by a wave. The kite filled and we took off planing at 16 knots. My bad . . . Hey, no harm no foul.

Nah, stupid, stupid, stupid, and I bet that woke the guys up down below. Does our Panda bite? No, he pops and stinks when wet. As it turned out, half the collar on his life jacket inflated when

we submerged him while doing the dead ant. He came up looking like Quasimodo, which was good for a belly laugh for the crew. After ten minutes of imbalance, he wondered aloud how he could deflate the thing. Pop! The other half inflated before he could finish his sentence, which was good for another belly laugh.

By 2 a.m. it was nuking. The wind



LATITUDE/ROB



ERIK SIMONSON/WWW.H2OSHOTS.COM



LATITUDE/ROB



LATITUDE/ROB

ERIK SIMONSON/WWW.H2OSHOTS.COM



had built to 40 knots and the seas with it. The little kite started to feel like the big kite. We dropped into a wave and kept going, still dropping, going and going, going and going for three times longer than on any other wave out there. That was a really big wave but we'll never know exactly how big. We couldn't see it. We were in the haunted house and the bioluminescence was flying off our bow like a welder's sparks. Safety scenarios were popping into my head — what to do if we're dismasted, what to do if we break

the rudder, what to do if we hit something. The ISAF qualification seminar from four days prior was kicking in. By 2:30 a.m. the wind had dropped back down into the 30s, but I was getting burnt. I'd been driving 2.5 hours. I did the math. There were three more hours until daylight. Could I make it? "Luke, use The Force, Luke. Do... there is no try." Ten minutes later and it was time to punt, I wasn't worthy of The Force yet, so Nate got the call. *(Editor's note: Silly wookiee, The Force is for Jedi Knights)*

Finally dawn, we'd made it out of the haunted house with only two round-downs — both self-induced. Thank you Mr. Mancebo. The wind had dropped to 25 so we shifted up to the big kite, which was a piece of cake after the previous night's wild ride. We passed some big boats with no little boats around — a good sign. By mid-morning we were heating it up to try to stay on course. After an hour, we're still over 30 degrees below course. Did we swing too wide? Would it lift us

# THE RACING

as expected as we approached Santa Barbara? We switched to a jib because the big kite wasn't working anymore. Suddenly we were on course but the boat speed had dropped to seven knots and our ETA had jumped from 5 to 10 p.m. Arrive in the Land of Girls well after a Joe's Cafe steak dinner? Inconceivable! So we set the fractional kite. We were way low, but *Bloom County* was ripping off 14s again on a tight reach and the ETA had dropped back down. It's supposed to lift right? Then the wind built to over 30 and backed. The boat was struttin' her stuff in the high-teens again. We were passing waves and busting through them like a little Volvo 60 for hours and hours. While the previous night was one of the wildest rides, this is one of the best rides — it was pure joy.

By 4 p.m. the wind had backed even more, and the breeze was blowing 20 knots; we were squared back with the big kite up and enjoying Pink Drinks.

At 5 p.m. there was a big boat ahead of us that turned out to be the Farr 49 *Javalin* coming out from the inside while we came from out past the oil rigs. Santa Barbara was so close we could taste it. All of a sudden, the big boat parked up, so we decided to swing even wider. Forty minutes later we parked up. The next five minutes weren't pretty. The whole crew came unglued. There was no wind, yet still plenty of swell to throw you around. The Santa Barbara YC was right there, but we couldn't get there from here. We were thinking that we were doing extremely well overall, but the idea that we could lose it all right there was kicking



**Sir Geoffrey Mulcahy's 'Noonmark VI' won the Gibbs Hill Lighthouse trophy in the '10 Newport Bermuda Race. Results at [www.bermudarace.com](http://www.bermudarace.com).**

in. It took about five minutes to adjust to the mindf=+k of going from planing to "zenning." Finally, we broke-out the matches to check which way the smoke was blowing and went to work. Light air isn't *Bloom County's* forté. She gets sticky in under six knots of breeze. After an hour, an easterly started forming and finally got to us. "Gotta finish before dark, before everything shuts down," became the mantra. After an hour of light air beating we finished at 7:49:36 p.m. and won the '10 Coastal Cup overall by a little over 16 minutes.

— Jon Stewart

## Double Trouble — J/125

**Andy Costello**

What a race! I thought I had a good idea of what a really good race crew and good sailors are until we hit sunset on

Thursday night. Then these guys showed me another level of sailing I didn't know existed. This was my first overnight race. I've done a ton of buoy racing and day distance races but this was my initiation to night racing. It was amazing to watch Trevor Baylis, Patrick Whitmarsh, and Jeff Thorpe drive the boat in these conditions in the pitch dark. We were so underwater by 2 a.m., the instruments started to die, including the bow light. Trevor was driving the boat at 10/10ths with no instruments or sight reference, just the feel of the boat . . . just amazing stuff. The water spraying over the coachroof and onto the deck looked like the Fourth of July as it was filled with bioluminescence glowing brightly in the pitch black. Mark Breen is a fantastic trimmer and great driver and Jonny Goldsberry owned the bow. We lost sight of him through white water on many occasions during sail changes, and he was banding the kites through the bumpy night, holding back getting sick and keeping the boat and all her lines flaked out so as not to have any issues when we couldn't see anything.

Leading the big boat fleet for the first 15 to 20 miles was really cool. Solid tactics by our team really overcame waterline and sail area. We knew early on, based on our performance out of the Bay, that if we got the breeze to plane, we had a good shot at the race.

Forty miles into the race we got a giant jellyfish hung up on the saildrive, which had the boat vibrating. We thought our prop was spinning so we took the saildrive

## THE BOX SCORES

BLUE — 1) **Reece Myerscough**; 2) **Frankie Dair**; 3) **Kailli Campbell**, 117. (18 boats)

RED — 1) **Kyle Larsen**; 2) **Jack Toland**; 3) **Jack Barton**. (23 boats)

WHITE — 1) **Ansgar Jordan**, 275 points; 2) **Daniel Pascal**, 316; 3) **Mats Kelden**, 320. (3 boats)

GREEN — 1) **Hannah Baylis**, 25 points; 2) **Sally Wilmot**; 3) **Teddy Russell**, 55. (11 boats)

Complete results at: [www.stfyc.org](http://www.stfyc.org)

### WEEKNIGHT:

#### OAKLAND YC SWEET 16 SERIES # 7 (6/16)

PHRF ≤ 150 — 1) **n/a**, Wabbit, Kit Wiegman; 2) **Golden Moon**, Express 37, Kame & Sally Richards; 3) **Spirit of Freedom**, J/124, Bill Mohr. (5 boats)

PHRF 151-200 — 1) **Morning Dew**, Kiwi 29, Vince Boley; 2) **Popeye & I**, Cal 9.2, Ruth Summers; 3) **Gonzo**, Santana 525, Dina Folkman. (6 boats)

PHRF 201+ — 1) **Chile Pepper**, Santana 25, Dave Lyman; 2) **Blueberry**, Nonsuch 22, John

Foster. (2 boats)

MULTIHULL — 1) **Pegasus II**, F-27, A&A Pitcairn. (1 boat)

NON-SPINNAKER — 1) **Magic**, Mercury, Joey Hansen; 2) **Iskra**, Mercury, Paul Mueller; 3) **Svenska**, Peterson 34, Fred Minning; . (8 boats)

COLUMBIA 5.5 — 1) **Tenacious**, Adam Sadeg; 2) **Alert**, Liem Dao; 3) **Sea Biscuit**, Peter Szasz. (6 boats)

MERIT 25 — 1) **Bewitched**, Laraine Salmon; 2) **Bandido**, George Gurrola; 3) **Double Agent**, Robin Ollivier. (4 boats)

Complete results at: [www.oaklandyachtclub.org](http://www.oaklandyachtclub.org)

#### SOUTH BEACH YC FRIDAY NIGHT SERIES (CUMULATIVE) (Sr. 1t)

SPINNAKER (PHRF ≤ 99) — 1) **Jolly Mon**, J/105, Chris Chamberlin, 12 points.; 2) **Jazzy**, 1D35, Bob Turnbull, 12; 3) **Alpha Puppy**, 1D35, Alex Farell, 12. (12 boats)

SPINNAKER (PHRF 100+, 4r, 1t) — 1) **Highlighter**, Islander 36, William Hackel, 3 points; 2) **Independence**, J/32, Joe Wells, 6; 3) **Northern**

Beer can series are in full-swing, and this month's Box Scores covers both weekend and beer can events. We don't have the time or manpower to chase down all the results, so please post them on your club's website or send them directly to the Racing Editor at [rob@latitude38.com](mailto:rob@latitude38.com). Our format is to include the name of the boat, the type and length of boat, and the first and last names of the owner(s). We'll do our best to get that info into *Latitude 38* and *Lectronic Latitude*.

### WEEKEND:

#### St.FYC OPTI HEAVY WEATHER REGATTA (6/19-20, 9r/1t)

ALL — 1) **Kyle Larsen**, 35 points; 2) **Jack Toland**, 36; 3) **Jack Barton**, 42; 4) **Sean Hachler**, 45; 5) **Lawson Willard**, 54; 6) **Lindsey Babb**, 56; 7) **Reece Myerscough**, 71; 8) **Alexander Fritz**, 74; 9) **Frankie Dair**, 74. (44 boats)



apart to check. It wasn't, so we did a kite down, backdown, hoist and back on our way in no time at all. Jonny was standing-by to dive overboard with a knife to check out the appendages if nothing came off — you couldn't get me to do that!

Our big jibe came in 30-plus knots of breeze at 10:30 p.m. with a full main up, and the A5. Jeff came up from the computer and called for the jibe. We all assumed our positions, then waited for Trevor to call it and send *Double Trouble* down the safest patch of ocean he could find. We must have been in position for at least 20 to 30 minutes or 8 to 10 miles at the speed we were going. In the pitch dark, the wind just kept getting stronger and stronger and was peaking over 35 knots. We were blasting down waves at 20 to 23 knots and I had no idea how we were going to turn this boat as we were going so fast down the waves that we would get to the bottom and punch through the next one. It was absolutely crazy, but eventually Trevor found the right spot and we pulled it off upright, and in control. I was amazed by the patience the crew had. There was not one word spoken in that 30-minute window, just focus, waiting for the call from the helmsman.

At sunrise we were off Pt. Conception in 30 knots of breeze, just flying over waves with our smallest kite and a reefed main pushing the boat to the limit. I felt as if we were on the Volvo Ocean Race. I thought to myself many times "we have to be winning this race; nobody is this

crazy and pushing this hard." I could not believe how fast we were putting the miles down! Between sundown and sunrise there was almost no conversation among the team, just pure concentration. I spoke to Jeff when he was at the nav station and he was impressed at how fast we were eating up the course.

As we ghosted into Santa Barbara, we were greeted by a hundred dolphins that played in our wake for a few miles. I got so excited I taped over all our awesome HD camera footage of our high speed evening and morning sailing. Fortunately I had Jeff's waterproof camera footage to make the video. At least my kids are stoked because I have HD dolphin footage, so that's a bonus. I want to thank Trevor Baylis, Jeff Thorpe, Patrick Whitmarsh, Mark Breen and Jonny Goldsberry for the best sailing experience I have had to date. They are great sailors and great friends. I am totally hooked on this offshore stuff now, and totally bummed to not be racing *DT* to Hawaii this year, but our crew and I have our eyes on next year's TransPac. We should have *Double Trouble* well sorted by then and will give it a go.

— Andy Costello



ERIK SIMONSON/WWW.H2OSHOTS.COM

John New's Hobie 33 'Wuvulu' lights it off at the YRA Summer Sailstice Race on June 19. You can find complete results at [www.yra.org](http://www.yra.org).

### Spinnaker Cup

The weather forecasts in the week leading up to the Monterey Peninsula YC- and San Francisco YC-hosted Spinnaker Cup didn't look too favorable for the roughly 90-mile run down the coast to Monterey on May 28. But after a 45-minute postponement, all five divisions set off in a building flood before rounding the corner and heading for Monterey in a westerly that built from the 8- to 10-knot range up to 30-plus knots farther down the course and clocked as the day wore on.

Andy Costello's J/125 *Double Trouble* crushed everyone to win both PHRO 1A and overall honors. David Rasmussen's Synergy 1000 *Sapphire* survived an

**Light**, Santana 35, Rod Neathery, 9. (12 boats)  
NON-SPINNAKER (PHRF  $\geq 154$  4r, 1t) — 1) **Carmelita**, Catalina 42, Christian Lewis, 3 points; 2) **All Hail**, Catalina 34, Page van Loben sels, 6; 3) **Kapai**, Catalina 34, Richard Egan, 9. (8 boats)  
NON-SPINNAKER (PHRF 155+ 4r, 0 1t) — 1) **Star Ranger**, Ranger 26, Simon James/Tim Walsh, 3 points; 2) **Synergizer**, Ericson 28, Larry Weinhoff, 8; 3) **Double Play**, Yankee 30, RDK partners, 7. (8 boats)  
CATALINA 30 (4r, 1t) — 1) **Adventure**, Jack McDermott, 3 points; 2) **Friday's Eagle**, Mark Hecht, 6; 3) **Huge**, Bill Woodruff/Tanya Keen/Peter Birch/Russell Houlston, 10. (7 boats)  
Complete results at: [www.southbeachyc.com](http://www.southbeachyc.com)

#### BALLENA BAY YC FRIDAY NITE GRILLERS SERIES #5 (5/28)

PHRF — 1) **Tortfeasor**, Olson 34, Jeff Rude; 2) **Legendary**, Jeanneau 41, Dave Edwards; 3) **Fermanagh**, O'Day 34, Frank Johnson. (7 boats)  
Complete results at: [www.bbyc.org](http://www.bbyc.org)

#### SAUSALITO YC SPRING SUNSET SERIES #4 (6/22)

DIVISION A (SPINNAKER) — 1) **Gammon**, Tartan 10, Jeff Hutter; 2) **Streaker**, J/105, Ron Anderson; 3) **Jose Cuervo**, J/105, Sam Hock. (6 boats)  
MULTIHULL — 1) **Origami**, Corsair 24, Ross Stein; 2) **Origami**, F-27 Greg Carter. (2 boats)  
DIVISION C (NON-SPINNAKER) — 1) **J Hawk**, J/133, Dale Fleming; 2) **Quicksilver**, C&C 39, Carl Robinette; 3) **Escapade**, Sabre 402, Nick Sands. (6 boats)  
DIVISION D (NON-SPINNAKER) — 1) **Encore**, Alerion Express 28, Dean Dietrich; 2) **Serendipity**, Cal 29, Phil Hyndman; 3) **Trasher**, Merit 25, Harriet Lehman. (11 boats)  
Complete results at: [www.syconline.org](http://www.syconline.org)

#### CORINTHIAN YC FRIDAY NIGHT SERIES #6 (5/14)

NON-SPINNAKER 1 — 1) **Min Flicka**, Hanse 370, Juella LeVicki; 2) **Salient**, Cal 39/2, Mark Pearce; 3) **Q**, Schumacher 40, Glenn Isaacson. (9 boats)  
NON-SPINNAKER 2 — 1) **Mimicat**, Hinckley 38, Robert Long; 2) **Shearwater**, C&C 36, Jeanne Lacy; 3) **Maxine**, Yankee 30, Stephen Spoja. (5 boats)

NON-SPINNAKER 3 — 1) **Belafonte**, Santana 22, James Robinson; 2) **Fjording**, Cal 20, Tina Lundh; 3) **Roadrunner**, Ranger 23, Gregory Demetruilus. (4 boats)  
J/105 — 1) **Yikes!**, Peter Stoneberg; 2) **Donkey Jenny**, Shannon Bonds; 3) **Alchemy**, Walter Sanford. (3 boats)  
SPINNAKER 2 — 1) **Pegasus 492**, Melges 24, Philippe Kahn; 2) **Yucca**, 8 Meter, Hank Easom; 3) **Nothing Ventured**, Melges 24, Duane Yoslov. (8 boats)  
SPINNAKER 3 — 1) **Wuda Shuda**, Soverel 26 OB, Craig Page. (1 boat)  
Complete results at: [www.cyc.org](http://www.cyc.org)

#### TIBURON YC FRIDAY NIGHT RACING #1 (5/21)

DIVISION 1 (PHRF < 157) — 1) **Joyride**, J/105, Bill Hoehler; 2) **Hurricane Gulch**, C&C 33, Richard Selmaier; 3) **Frenzy**, Moore 24, Lon Woodrum. (6 boats)  
DIVISION 2 (PHRF > 158) — 1) **Brigadoon**, Blackwatch Sloop, Bob Horton 2) **Wind Dance**, Cal 2-27, Ann Watson; 3) **Siento El Viento**, C&C 29, Ian Matthew; . (3 boats)  
Complete results at: [www.tyc.org](http://www.tyc.org)

# THE RACING

EPIRB scare — for everyone else — when *Sapphire's* went off accidentally, and won PHRO 1. The Doublehanded honors went to Skip and Jody McCormack's Farr 30 *Trunk Monkey*, which survived a wind check at 23 knots of boatspeed resulting in a shattered spinnaker pole. Mark Thomas' CM 1200 *Raven* took the honors in PHRO 2, while Steve Waterloo's Cal 40 *Shaman* won PHRO 3 for the sixth time in the last seven years!

We were fortunate enough to be invited aboard Bill Turpin's R/P 77 *Akela* for the race, and at least had it in the back of our minds that it would sure be nice to set a new elapsed-time record for the race. It's good to know there's at least one racing result we can't jinx here at *Latitude 38*, because *Akela* did in fact set a new record — its third so far this year.

Although we never got pressure above about 26 knots, we put the boat's prodigious waterline to good effect in knocking down the time to 7h, 11m, 6s, an 8-plus-minute improvement over the old record set by Lani Spund's SC 52T *Kokopelli*<sup>2</sup> in '06. While we were stoked enough to be invited aboard the boat, we were happier



ERIK SIMONSON/WWW.H2OSHOTS.COM

**Nine International Canoes showed up at the Richmond YC, June 20-21 for their North Americans.**

when we nailed the record, and happier yet that it's a soft one, within reach of more than a few boats on the West Coast.

The race wasn't without incident for

some of the boats. The crew of Steve Stroub's SC 37 *Tiburon* knocked a big gray whale out of their way! While none of the humans were hurt there was no word on how the whale is feeling. Crewmember Alan Cahill, who was driving when they hit the cetacean, commented afterwards, channeling Melville: "I saw all 32 teeth!"

## International Canoe North Americans

Nine International Canoes showed up at Richmond YC June 20-21 for their North Americans. Seattle boatbuilder Chris Maas eked out a narrow one-point victory over visiting Australian Hayden Virtue in the seven-race, one-throwout series. The top Bay Area finisher was Novato's Erich Chase in third, only three points out of first in his first time in the boat in seven years.

### INTERNATIONAL CANOE NORTH AMERICANS (6/19-20, 7r, 1t)

- 1) **Chris Maas**, 11 points; 2) **Hayden Virtue**, 12;
- 3) **Erich Chase**, 14. (9 boats)

Complete results at: [www.richmondyc.org](http://www.richmondyc.org)

26th Annual

Lasers  
Invited!

Come to  
the Party!

Bay View  
BOAT CLUB

THE BAY VIEW BOAT CLUB AND THE ISLANDER BAHAMA FLEET  
invite all

'60s & '70s Vintage  
Fiberglass Sailboats

to the  
San Francisco

PLASTIC  
CLASSIC

REGATTA

and

Concours d'Elegance

Saturday, July 17

at the Bay View Boat Club and the waters of Pier 54  
For more information visit our Web site: [www.bvbc.org](http://www.bvbc.org)

Bay View Boat Club  
489 Terry Francois Blvd., San Francisco, CA 94107

TROPHIES TO PRETTIEST BOAT AND FASTEST OVERALL

10 a.m. UNTIL DARK • RACE STARTS AT 1 p.m. • TROPHY PRESENTATION AT 7 p.m.

**Race Notes**

*College Nationals* — The University of Wisconsin hosted the **ICSA Spring Nationals** May 25 through June 3 on largely windless Lake Mendota. In the women's event, the College of Charleston Cougars — led by Southern Californian Allison Blecher — won the title going away. Blecher and sophomore crew Alyssa Aitken finished 28 points clear of division and regatta runner-up Boston College. Defending Dinghy National Champion St. Mary's College Seahawks took the ICSA/APS Team Racing Nationals, led by Newport Beach sailor Michael Menninger, with a final-race appearance by the Bay Area's Mike Kushner. In the ICSA/Gill Dinghy National Championships, Boston College won a regatta shortened by lack of breeze. San Diego's Tyler Sinks and Briana Provanča and Palo Alto freshman Laura McKenna led the way for BC. Complete results are available at [www.collegesailing.org](http://www.collegesailing.org)

*We've been wondering when this would finally happen* — The RC 44 class announced last month that it would be

coming to America after three successful years on a European and Middle East circuit. The first American event, the **Oracle RC 44 Cup Miami**, will be held December 7-12 in its namesake city.

The brainchild of BMW Oracle Racing CEO Russell Coutts and designer Andrei Justin, the 44-ft container-shippable day racer has proven popular among America's Cup teams and private owners alike. The format for its events include match racing with a professional driver followed by fleet racing with an amateur driver. The circuit also includes logistical support including a crane that travels from venue to venue to get the boats off their cradles and onto their keels, as



LESLIE RICHTER/WWW.ROCKSKIPPER.COM

*SFYC/StFYC sailor and top girl Lindsey Babb (15024) at the Opti Heavy Weather Regatta June 19-20; the results are in the Box Scores on page 128.*

well as raising their rigs.

The class has a strong Bay Area connection with sailors like Paul Cayard and Morgan Gutenkunst being regulars on the circuit and Bay Area product Dee Smith as the American agent for the boat; we'd be surprised if San Francisco

**THE LATEST ADVANCEMENTS IN THE FIGHT AGAINST BLOOD CANCER WON'T BE FOUND IN A HOSPITAL OR IN A LABORATORY.**

**THEY WILL BE FOUND AT SEA.**

Raise a sail to find a cure. The fifth annual Leukemia Cup Regatta benefiting The Leukemia & Lymphoma Society is October 2nd and 3rd at The San Francisco Yacht Club in Belvedere, CA. VIP dinner featuring America's Cup champion, Russell Coutts.

Register at: [leukemicup.org/sf](http://leukemicup.org/sf)



# THE RACING

isn't in their sights in the future. Check out the class at [www.rc44.com](http://www.rc44.com).

We've also been wondering how long this would take — The Newport Ocean Sailing Association (NOSA), organizer of the **Newport to Ensenada International Yacht Race**, and **XS Racing**, founder of the upstart **Border Run International Sailing Event** to San Diego, are happy to announce they have reached an agreement for 2011 that will allow sailors to participate in both events.

With the help of Border Run organizer South Shore Yacht Club and ORCA the Ocean Racing Catamaran Association, the two parties have created a set of guidelines they feel will serve the greater good for local sailors. ORCA, was instrumental in moving the process forward by creating a new 'Extreme' class to once again includes the Reynolds 33 catamaran in the Newport to Ensenada Yacht Race. With this new agreement, the two multihull fleets will be race in one fleet, but under two rating systems.

Newport to Ensenada Race organizers will award trophies for two multihull classes, similar to how they recognize



COURTESY TIBURON YC

**Jack Barton, left, and Rob Horton Jr. will be sailing in the Sears Cup Finals in San Diego in August.**

IRC or ORR boats that race within the PHRF class. West Coast multihull sailors can now join both XS and ORCA to get two ratings and be scored under both systems, creating a larger fleet of racers. NOSA was also very active in making this happen. As a result of the new agreement, and to allow sailors to participate in both events, South Shore Yacht Club and XS Racing have set the start of the '11 Border Run International Sailing

event on April 9, 2011, the weekend before the Newport to Ensenada start. For more information on the Ensenada race go to [www.nosa.org](http://www.nosa.org). For information on the Border Run go to [www.TheBorder-Run.org](http://www.TheBorder-Run.org).

*This looks fun* — The stretch of California coastline between Monterey and Santa Barbara isn't really known for sailboat racing, but the Morro Bay YC and San Luis YC are teaming up again this year for the **Zongo Yachting Cup** — a 20-mile ostensibly reach-and-run race from Morro Bay to Avila Beach on August 20. Last year's inaugural edition brought out nine boats — some of the smaller boats were scared away by a forecast for wind to 50 knots. As it happened, the race only got a solid 25 knots and following sea, and this year there are 20 boats signed up already.

There will be a cruising class where everyone anchored out in Avila Beach by 5:30 p.m. is a winner, and a racing class sailed under PHRF ratings. The race is named for the race party's headlining act, the Afro-Caribbean dance band the



## SEE THE DIFFERENCE?



### YOU CAN'T - UNTIL IT'S INSTALLED!

All riggers offer the same hardware at the same price. The difference is the expertise, installation and value. You won't see a difference in the product, but you will see it at the finish line!



#### Easom Racing and Rigging

1230 Brickyard Cove Rd., Suite 102  
Point Richmond, CA 94801

**(510) 232-SAIL (7245)**

[www.easomrigging.com](http://www.easomrigging.com)

Zongo All-Stars that features large horn, percussion and electric rhythm sections and is one of the most popular bands on the central coast. The organizers have thoughtfully scheduled the event to coincide with Avila Beach's lively Friday afternoon farmer's market, where the Zongo All-Stars — along with a cadre of guest musicians from all over the state — will play before moving over to Avila's only nightclub, Mr. Rick's, until 1 a.m. This would be the perfect event for anyone headed south a little earlier in the year, or for trailerables that can be ramp launched or are under 2,000 pounds displacement. To us it sounds like a perfect event for a Moore 24, Open 5.70 or anything else in that size range. There's information up on the Morro Bay YC's website at [www.mbyc.net](http://www.mbyc.net).

*Onward and upward* — The Sausalito YC team of skipper Kate Anderson, Daniel Rosic and Nick Dedona finished the **Area G qualifier for the Sears Cup** hosted by Tiburon YC June 13 thinking they'd won a trip to the finals. The trio finished one point ahead of the San

Francisco YC team of Rob Horton Jr., Scott Buckstaff and Jack Barton. But they found, much to their dismay, that because two of them weren't US Sailing members, they were DQ'd from the regatta. It must have been a hard lesson, but now is the time in life to learn those. And so Horton, Buckstaff and Barton will advance to the US Sailing Chubb Jr. Championships in Mission Bay in August, where they'll competing for the Sears Cup — the US Sailing triplehanded junior championship — in Lightnings. Racing in breeze that ranged from 12 to 22 knots, the five Bay Area teams sailed a round-robin series in J/22s provided by Cal Maritime following a coaching session led by US Sail-



JERRY LEWIS

*The Ultimate 20s roll in for a finish at the Go for the Gold Regatta on Whiskeytown Lake.*

ing Team AlphaGraphics member Molly Carapiet.

The qualifiers for the Bemis — doublehanded — and Smythe — singlehanded trophies will be held as part of the Encinal YC's Svendsen's Summer Splash on July 10-11.

Mark your calendars for these upcoming events at South Beach Yacht Club!

## J/120 and IRC South Beach Invitational

PETER LYONS/WWW.LYONSIMAGING.COM



August 21-22 • South Beach Yacht Club  
Pier 40 The Embarcadero, San Francisco

*Open to all J/120s and IRC yachts.*

Two days of buoy racing on San Francisco Bay in the flat waters and steady winds south of the Bay Bridge.

Saturday night post-race party, dinner and live music!

*South Beach Yacht Club & Benicia Yacht Club  
are proud to present the 22nd Annual*

## JAZZ CUP SAN FRANCISCO TO BENICIA

MARGARET FAGO



**Saturday, September 4**

*Best in Downwind Racing*

[www.southbeachyachtclub.org](http://www.southbeachyachtclub.org) • (650) 333-7873 • [RearCommodore@southbeachyachtclub.org](mailto:RearCommodore@southbeachyachtclub.org)

# WORLD

With reports this month on **Chartering Options for Solo Travelers**, and part two of **Bareboat Chartering in the Forbidden Waters of Cuba**, and miscellaneous **Charter Notes**.

## The Sure-Fire Antidote For the Solo Traveler Blues

Some solitary individuals are completely comfortable living all alone, dining out at a table for one, and even vacationing solo. But most of us — being the innately gregarious creatures that we are — crave social interaction in practically everything we do. So when none of our friends or family are available to join us for a sailing getaway, we reluctantly conclude that we'll simply have to shelve our sun-kissed fantasies and stay home.

But you needn't think that way. Truth is, there are dozens — if not hundreds — of worthwhile sailing adventures that individuals can sign on to, all over the world. And we intend to make the case here that if you have the right attitude, doing so can be as much fun, if not more, than traveling with your usual crowd.

Back in ancient times — the '60s and '70s — before hitchhiking became largely taboo, we spent a lot of time transiting the Golden State courtesy of our thumbs. (If you'd seen some of the cars we owned back then, you'd understand why hitching was substantially less stressful than driving.) Despite getting stranded in the middle of nowhere a few times, we usually got where we were going, and an unanticipated benefit was that we met all sorts of colorful characters whose tall tales helped pass the time while broadening our worldview. One of the lessons learned during those freewheeling days was that sometimes when you step outside your

*There really are places where the water's so clear you can see the bottom, like Raiatea's Nao-Nao. A flotilla cruise can take you there.*

normal comfort zone, life presents experiences that make your travels far richer than they might have been otherwise. For that reason, we've never since been reluctant to travel solo. There always seems to be an interesting new friend to meet around every corner.

In the realm of sailing, the range of experiences that an individual traveler can access is broad and varied. Some are focused on carefree island-hopping, while others include educational components. Some offer luxurious accommodations and some are expeditionary in nature, taking you to remote locations where you'd never find a bareboat or crewed charter yacht. Let's have a look at some of the prime possibilities.

If you live in or near the Bay Area, a wealth of book-by-the-berth vacation options are accessible through local sailing schools (or clubs). Most offer several bareboat sailing flotillas annually in exotic sailing venues — and you don't necessarily have to be a club member to sign up.

For example, a group from Tradewinds Sailing School will cruise the Sea of Cortez this month, and they're putting together a Thailand trip for November. Sailors from OCSC will visit Turkey in September and Antarctica next February. Spinnaker Sailing of Redwood City will host a flotilla in Croatia in September and another in the British Virgins in December. Club Nautique is offering a series of California coastal cruises this fall, as well as a BVI trip in November. In October, Modern Sailing is offering a first-ever cruise from Mallorca to Morocco and on to Gibraltar, then a second leg from 'the



rock' out to the Canary Islands.

All of these trips provide easy means of escaping the rat race without having to spend countless hours researching and planning. For would-be bareboat skippers, they give first-hand insights into what's involved in day-to-day boat operations, without having to take total responsibility for the boat.

Hands-on instruction is an added bonus on some of these trips, and in some cases participants who successfully complete the requirements come home with an ASA or US Sailing course certificate as a special souvenir.

As we've often noted in these pages, larger bareboat companies, such as Sunsail and The Moorings, offer many scheduled flotillas in popular destinations like the British Virgins, Greece, Turkey and Croatia. For some reason Europeans love the flotilla concept. In the Med and Adriatic during the summer months you'll find bebies of bareboats traveling similar routes, and the sailors aboard them always seem to be having a ball. This sort of travel isn't for everyone, but if you're outgoing and like to mix with an international crowd, booking a spot on a flotilla could be the perfect antidote for the solo traveler's blues. (See [www](http://www).



DAVID KORY

# OF CHARTERING



JENNIFER

**Aboard world-cruising boats like the Beneteau 50 'Jennifer', sailors from many nations share adventures and often become friends.**

moorings.com, [www.sunsail.com](http://www.sunsail.com), and for Greece, also check out the special cruises offered by Albatross Charters at [www.albatrosscharters.com](http://www.albatrosscharters.com).)

At the other end of the spectrum are all sorts of 'tall ship' cruises that are booked by the berth and take 'swabs' of all ages. We recently reported on schooner sailing in 'downeast' Maine, which is a book-by-the-berth option that we'd highly recommend. (Check out the Maine Windjammer Association at [www.sailmainecoast.com](http://www.sailmainecoast.com) and the North End Shipyard Schooners at [www.midcoast.com/~schooner](http://www.midcoast.com/~schooner).)

You can also find similar cruises — where hands-on participation is part of the fun — in the Puget Sound region aboard the former San Francisco Bay pilot schooner *Zodiac* ([www.schoonerzodiac.com](http://www.schoonerzodiac.com)) and others. In the South Pacific you can get a healthy dose of marlinspike sail training aboard the splendid 142-ft barquentine *Soren Larsen* ([www.sorenlarsen.co.nz](http://www.sorenlarsen.co.nz)), which makes annual inter-island circuits. Additional tall ship options can be accessed through the American Sail Training Association, which offers

a wealth of opportunities for would-be salts of all ages ([www.sailtraining.org](http://www.sailtraining.org)).

Tall ship sailing not only gives you insights into the roots of modern seamanship, but it's a natural camaraderie-builder, as such vessels cannot function unless all hands work together. In this vane we should also mention some luxurious variations on the theme: the three Star Clipper ships. Measuring 360 to 469 feet, each of these magnificent vessels combines the posh amenities of an elegant cruise ship with the classic lines of a vintage tea clipper — and they really sail whenever possible. Our dream is to someday do a transatlantic repositioning cruise aboard one between the Med and Caribbean ([www.starclippers.com](http://www.starclippers.com)).

If you've got a truly adventurous spirit, consider joining an instructional offshore cruise with a modern offshore sail training vessel. The two that come immediately to mind are the S&S 65 *Alaska Eagle*, operated by Southern California's Orange Coast College School of Sailing and Seamanship, and the Washington-based Hallberg-Rassy 46 *Mahina Tiare*, run by lifelong

voyagers John and Amanda Neal. Between October and April 2011, the *Eagle* will sail a 7-leg itinerary from her Newport Beach homeport around the Horn, to South Georgia Island and on to Antigua ([www.occsailing.com](http://www.occsailing.com)). *Mahina Tiare* is currently exploring the South Pacific. In September she'll head south from Vanuatu to New Zealand, then work her way back to Tahiti by May with stops at remote islands all along her route that are rarely visited by cruisers ([www.mahina.com](http://www.mahina.com)).

Another world-roving option that comes highly recommended by Bay Area sailor John Thompson and others is the Beneteau 50 *Jennifer*, run by Swedish explorer/author Lars Hassler. For nearly 20 years, he's been introducing adventurous crew members to far flung destinations as diverse as Vietnam and the Black Sea. This summer he'll take *Jennifer* from the Med through the Red Sea to Dubai and India, then on to the Maldives and Thailand. Next year he'll be off to Borneo, China, Japan, Alaska, Canada and California ([www.yacht-jennifer.nu](http://www.yacht-jennifer.nu)).

There are, of course, other independently operated offshore programs well worth joining, but we think it's essential to do background research on them and get references before signing on.

All in all, the realm of book-by-the-berth sailing is a vastly under-utilized vacation option by would-be solo travelers. Now that you've been introduced to

**"All together now. . ." Aboard the Star Clipper vessels, pitching in with sailing chores is optional. But who'd want to miss all the fun?**



STAR CLIPPERS

# WORLD

it, you've got no reason to procrastinate. So get up off the couch and go!

— *latitude/andy*

## Chartering in Forbidden Waters: Part Two

*Readers — We continue here with the second installment of our first-ever report on bareboating in Cuba. When we left off last month, Roger Davis and his fun-loving crew were about to make the 18-mile sail from Cayo Largo to Cay Rosario.*

When weighing anchor, we discovered that we'd lost forward thrust on the starboard engine. I dove in and had a look, then we noodled with things, eventually deciding to go to Cayo Rosario with one engine rather than frittering away precious vacation time diagnosing the problem.

Cayo Rosario has a beautiful deserted beach, silky white sand with pink hues. The beach is roughly 4 miles long. We anchored in 8 feet of water, about 3 miles from the eastern tip of the island.

There is a great snorkeling spot on the island's southern tip, to the west of



ALL PHOTOS ROGER DAVIS

**"More lobster? Oh, if we must." Although scarce in most Caribbean islands, Cuba seems to have plenty of these spiny crustaceans.**

where we anchored. The reef was beautiful, with wonderful fan corals and colorful fish. There were two boats anchored inside of the reef, so we figured there must be a channel between the reefs.

Lalo, our divemaster, pointed out

interesting things while snorkeling, including flamingo tongues and a lion fish. Despite their exotic allure, these fish are apparently aggressive and invasive, wreaking havoc on reef ecosystems. Researchers are studying how to get rid of them.

About the time we were pondering what to eat that night, three fishermen motored over and offered us lobster. We traded for additional lobster, with soap, beer, Coca Cola, and a T-shirt. Again, we found ourselves in lobster heaven. Carmen spoiled us with her lobster risotto.

The stars were out again that night, which inspired part of the crew to crash on the tramps.

The next morning we awoke to a bit of Norte, and things were a little rolly. I was half dreaming, and enjoying my sleep. I could hear Aldo and Lalo working on the starboard prop issue, which was wonderful. Lalo improvised a SNUBA setup for close underwater work, and Aldo disassembled the panel on the opposite side of the throttle, inside the salon. They soon succeeded! The cable housing that

Tortola BVI  
Belize  
The Grenadines

UNIQUELY  
TMM

Most charter companies offer blue water & palm trees, but it takes the personalized care of people like Marisa to make your vacation a success.

Like Marisa, everyone at TMM is committed to your complete satisfaction. Our specialized three-location operation offers large company quality with small company service. A combination that is uniquely TMM.



**TMM**  
Yacht Charters  
Since 1979

catamarans • monohulls  
motor yachts  
ownership programs



Marisa  
TMM Belize

Real People. Real Sailing. Real Fun.

Sail Cats | Power Cats  
Monohulls | Trawlers  
Bareboat | Skippered

Real Choices.

Choose CYOA and become part of the family. We've been providing beautifully maintained yachts, personal service and sensible prices to sailors since 1980.

1-800-944-2962  
info@cyoacharters.com  
www.cyoacharters.com  
St. Thomas USVI 00802



CYOA

YACHT CHARTERS



# OF CHARTERING

connected to the shifter had become dislodged, with the crucial part resting inside the wall. We now had two fully operational engines again. Congratulations to Aldo! The crew immediately forgave him for the groundings and for fouling the prop.

We had a great walk on the beach. There were rays close to shore, and one followed me as I walked along. The sand there has large patches of beautifully rose colored hues. Maybe this is why they call the island Cayo Rosario? We dinghied back to the boat and relieved Aldo, who was eager to do a little beach-combing himself.

Afterwards, Aldo wanted to take *Cohiba* back to Cayo Largo so we could return to Cienfuegos the following day. The crew voted in support of the idea. So we got to see our immigration friends again — oh joy.

That evening, the Grasshopper convinced Aldo and me to meet up with his new bartender friend, and go to the nearest disco. After a bus ride to a resort, we discovered that the mainland has much

better discos. When we returned on the bus, it was crowded with locals — actually employees of the resorts. The average Cuban citizen is apparently not even permitted to visit Cayo Largo. The fun part was that they were all singing loudly in sync with the bus' music.

The next morning we departed from Cayo Largo at about 0800, and started back to Cienfuegos. But we couldn't leave immediately because the immigration officials had to come on board yet again, and do their thing.

"Wait," I thought, "the light wind is again on our nose!" So, we mostly motored back to Cienfuegos, arriving in the later afternoon. We walked to Club Cienfuegos for *mojitos*, but soon returned



*Anybody got a light? Considering Cuba's affinity for cigars, our anti-smoking laws must seem laughable to the islanders.*

to *Cohiba* for a final wonderful meal prepared by Carmen.

Afterwards, as usual, Grasshopper advocated that we go out for more dancing and carousing, but this time there were no takers. We had an early night.

## Cruise the WEST COAST of COSTA RICA aboard the LUXURY TALL SHIP *Star Flyer*

**A sailing experience,  
where the work  
is optional!**



**BOOK EARLY** for Savings of **25%-40% OFF** of brochure fares on selected sailing dates through March. *Offer is capacity controlled, so don't wait too long to decide!*

Enjoy **7-Day Cruises** where the sounds of the jungle and the ocean's surf strangely intermingle. You'll be dazzled by this natural paradise as you visit Cost Rica's National Reserve of Curu and Isla Tortugas, Drake Bay, Isla de Coiba, Quepos, National Park Santa Rosa and more! Some cruises include calls in Nicaragua and Panama! The 170-passenger *Star Flyer* is a gorgeous 360-ft long, 3-masted Barkentine-rigged sailing ship. Check the web site for videos, virtual tours, and more details: [www.starclippers.com](http://www.starclippers.com)

*For inquiries, reservations or a FREE BROCHURE, call:*

**Special Clipper Ship Instruction:**  
Hands-On Sailing Maneuvers on Deck  
Knotting Classes • Navigation Classes  
Dinghy & Laser Sailing

**THE CRUISE DIRECTOR, INC.**  
**(650) 592-6048 (800) 533-7111**  
email: [off2sea@pacbell.net](mailto:off2sea@pacbell.net)



California Seller of Travel  
#1002066-40

# WORLD

After squaring things away at the marina, we were set to taxi to Havana. But before leaving Cienfuegos, we decided to stop at the local ballpark. We traded for hats and jerseys, and I gave away a baseball to a grateful, wide-eyed Cuban kid.

In the capital, we stayed this time at Palacio O'Farrill, in Old Havana. It's an excellent restored hotel close to Plaza de Armas.

Aldo and I lingered in Havana for an extra day after the rest of the crew said their good-byes. We mainly wandered around Old Havana, checking out restored plazas and beautiful buildings. We managed to visit most of the plazas, and had a look at several old hotels.

A few final tips: On the currency front, you should bring Euros or other European currency to exchange, as they charge a 10% penalty to exchange U.S. dollars for Cuban CUCs — the convertible peso. Locals do not use CUCs. They use another peso (which I believe equates to about 24 to 1 CUC). I was advised to bring small denominations of dollars because, after all, dollars are "king" around



ALL PHOTOS ROGER DAVIS

**Cuba's immigration bureaucracy seemed a bit over the top. But after repeated check-ins, the officers had practically become friends.**

the world. This is not so in Cuba. In fact, the bellhop in our hotel asked me twice if I would buy his dollars from him.

In general, the food in Cuba is lousy and overpriced, with *jamon y queso* sand-

wiches serving as the mainstay. You can find some decent places, however. Aldo and I particularly loved Taberna de la Muralla, in Plaza Vieja. The government is restoring buildings one by one in this plaza, and this restaurant/brewery serves decent food at outdoor tables on the square — "the best *hamburguesa con queso* in Havana." The capital city also has "private" restaurants that seem to be better in general than the state-owned establishments. You can ask your hotel to make a recommendation for you.

Everyone in Cuba is crazy about baseball, and we were there when the Cuban world series was beginning. In Parque Central, there is a spot where the Cuban men gather to argue endlessly about the sport. We brought along a few baseballs to give away on this trip, and I wish we had packed more. The Cuban kids loved to get new baseballs.

As mentioned earlier, we visited Hemingway's spot, La Floridita, but could not get into his other watering hole, La Bodeguita del Medio, which was always way too crowded. La Floridita is definitely

## BRITISH VIRGIN ISLANDS

# "BEST DEALS ON KEELS"



- Most selection of sailboats 32'-52'
- "Purr" with cats 38'-47'
- Bare boat or skippered
- Best yacht management program

**Conch Charters**

Est. 1986

**NEW YACHTS IN FLEET!**

**www.conchcharters.com**

Email: [sailing@conchcharters.com](mailto:sailing@conchcharters.com)

Call our 'Sails' Office  
(USA) (800) 521-8939

Tel (284) 494-4868 • Fax (284) 494-5793

*Sail paradise with Conch Charters*

CALIFORNIA'S CARIBBEAN CONNECTION

"We had a true, worry-free 14 days of sailing. We got everything we asked for and then some!"  
A satisfied BVI Yacht Charters Guest

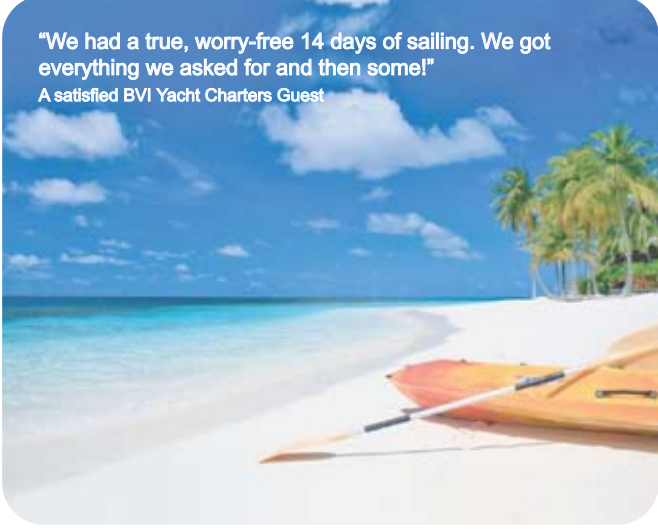



**BVI YACHT CHARTERS**

Call: +1 888 615 4006  
Or: +1 284 494 4289

BVI Yacht Charters is the first port of call for all yacht charters in the BVI. Whether you are looking for Bareboat or Crewed yachts, a Catamaran or a Monohull, a week or just a few days, our professional team is on hand to make it work, your way.

## BVI YACHT CHARTERS

[www.bviyc.com](http://www.bviyc.com)  
[charters@bviyc.com](mailto:charters@bviyc.com)

# OF CHARTERING

touristy and overpriced, but I think it's a must for every Hemingway fan.

Things are expensive in Old Havana and very touristy. In many ways, it reminds one of Old San Juan in Puerto Rico, but you see the signs of the embargo everywhere. Locals line up to make phone calls, and you see numerous decayed buildings with people living in them. Good food is definitely hard to find, and there are beggars and scammers all around.

If you like Latin music and salsa dancing, Havana should be on your list to visit. It seems there is live music everywhere. Live bands played in many restaurants, including La Floridita and La Taberna de la Muralla, as well as in the squares.

We went to a dinner show at La Nacional (50 CUC per person), featuring remnants of The Buena Vista Social Club (Grupo Company Segundo, Pareja de Baile "Los Santos") — with an eight-piece band and professional salsa dancers. The food was terrible, but the show was fantastic. When was the last

time you were indoors listening to amazing Cuban salsa music and smoking Cuban cigars? Salon Rojo, just up the street from La Nacional, is a high end, wild discotheque (55 CUC for a table with a bottle of rum with Cokes). Aldo was not admitted in his flip flops, and had to return to the hotel to get proper shoes. We also visited La Casa de La Musica, which featured another eight-piece band, but with Cuban girls once again chasing Aldo for sex and CUCs. That night after returning from La Casa de La Musica, one of the bellhops at the hotel summoned Aldo and me to the front desk area and presented a beautiful girl for the evening. "Well, ah. . . wow, no gracias."

We will return to Cuba someday.



**The Cuban government is slowly restoring many classic old buildings. But according to Roger, the food could also stand upgrading.**

Next time hopefully the bureaucracy will have lightened up, both there and in the United States. In the meantime, we're pondering where our next chartering destination will be.

— roger davis

## HASTY HEART

*Now available for charter*



*You imagine it – we'll plan it.*

61-ft Swan

(415) 690-7245 or [www.sailhastyheart.com](http://www.sailhastyheart.com)

## SAN JUAN ISLANDS



### Bareboat Charter Sailing

Fly to Bellingham, WA and set sail to explore the beautiful San Juan Islands! Charter bareboat or with a skipper. Our fleet of 33 sailboats and a growing fleet of trawlers offer you the newest vessels available for charter. All are maintained to the highest standards of preventive maintenance in the charter industry worldwide! (Airfare SFO/OAK to BLI approx. \$250)

Ask for our "\$100 Off" Latitude 38 Special!

CHARTER

40 Exceptional Yachts  
from 30 - 49 feet



SCHOOL

AMERICAN  
SAILING  
ASSOCIATION

28 Years of Sailing Excellence

We certify more Bareboat Skippers than any other school in the Northwest!

1-800-677-7245 • [sanjuansailing.com](http://sanjuansailing.com)

# WORLD OF CHARTERING

Roger — Many thanks for your insights. Although modern infrastructure is lacking, chartering in Cuba now, before rabid development arrives, is an enticing idea. We'd just need a non-American to pay all the bills!

## Charter Notes

With all the emphasis in this edition on sailing in far-flung destinations, a newcomer to the **Bay Area** might think there was no worthwhile sailing to be had in our home waters.

Nothing could be farther from the truth, of course. As every longtime local sailor knows, the Bay is renowned as one of the **greatest sailing venues on earth** — and conditions are usually best in **late summer and fall**. So we'd encourage you to get out there and enjoy it as often as possible.

If you don't have a boat of your own, let us remind you that there are dozens of well-maintained sailboats in the Bay Area available for **bareboat rent-**



*Been a while since you took a mellow daysail on the Bay? Why not climb aboard 'Excalibur' and put her through her paces?*

**als**, as well as a sizeable fleet of **crewed charter yachts of all types and sizes**. You'll find a comprehensive list of them in April's *World of Chartering* section. (You can download that entire edition and others at [www.latitude38.com](http://www.latitude38.com).)

Actually, that list is not *totally* comprehensive. In fact, we're beginning to

hate that word, because as hard as we try, we occasionally leave a boat or two off the roster.

This year, it happened to Jonathan Ganz' well-kept **Sabre 30 Excalibur** based at Pt. Richmond's Brickyard Cove. He describes her as "sea-kindly, and perfectly suited to Bay conditions." Capt. Ganz, who's been sailing the Bay since the '80s and is a licensed sailing instructor, explains that his sloop is **available for all types of charters**, including team-building events, relaxed day charters, day- and nighttime sailing lessons, and various workshops, such as COB practice and motoring skills. "I love to introduce people to the world of sailing," he explains. If you're interested call him at (866) 766-4904, email [info@sailnow.com](mailto:info@sailnow.com), or check out his website at [www.sailnow.com](http://www.sailnow.com).

If we missed any other local charter operators out there, it was not intentional — honest. Just let us know, and we'll be happy to give your outfit a plug too.

## SAIL THE BAY

### SAILING CHARTERS

Bareboat or Crewed

Specializing in private, customized charters departing from all over the Bay.

**ALSO:** See our Web site for great deals on a variety of sailing products and equipment



Pescado, our 45-ft Catalina Morgan Deck Salon

[www.sailthebay.com](http://www.sailthebay.com) → (408) 891-1193



Discover, Explore & Live Your Dream



SAIL • DIVE • SNORKEL

Join SV Simpatica — Make a difference for kids in Africa

See the world from a different perspective [www.247sailing.net](http://www.247sailing.net)

What's a summer day's cruise in the Pacific Northwest?

*How about 17 hours of daylight!!!*

- San Juans
- Gulf Islands
- Desolation Sound

## Bellhaven Yacht Sales & Charters

Power & Sail Charters  
ASA Sailing & Power School

[www.bellhaven.net](http://www.bellhaven.net)  
[bellhaven@bellhaven.net](mailto:bellhaven@bellhaven.net)  
**877-310-9471**



Authorized Dealer

BELLINGHAM, WA

## Cruising Expeditions

### Offshore / Coastal Passagemaking Instruction

Mexico 2010-2011

Learn passagemaking and cruising skills from 20-year sailing veteran: daily participation in instruction material, sailing drills and safety checks.



Instruction / Itinerary / Package Details:  
[www.CruisingExpeditions.com](http://www.CruisingExpeditions.com) (805) 481-4567

# JUST YOU AND THE SEA...



...and the jacuzzi,  
the 80-ft long pool, the surf,  
the Punta Mita anchorage, and the 4-mile distant  
Tres Marietas Islands

## Punta Mita Beachfront Condos

*Call now for reservations!*

**1.415.599.5012**

[www.puntamitabeachfrontcondos.com](http://www.puntamitabeachfrontcondos.com)



# VALLEJO MARINA



Gateway to the Bay & Delta

## JOIN US FOR THOSE WARM SUMMER NIGHTS!

- Competitive Rates!
- Ample Guest Dock
- Full Service Boat Yard and Chandlery
- 2 Restaurants for Breakfast, Lunch, Cocktails and Dinner
- Covered and Open Berths



**(707) 648-4370** • Fax (707) 648-4660

42 Harbor Way • Vallejo, CA 94590

[www.ci.vallejo.ca.us](http://www.ci.vallejo.ca.us) [marina@ci.vallejo.ca.us](mailto:marina@ci.vallejo.ca.us)

## COAST MARINE

**& INDUSTRIAL SUPPLY INC.**  
398 Jefferson St. San Francisco - On the Wharf.

Call **Bruce Becker**: (415) 673-1923  
**800-433-8050**  
Fax (415) 673-1927



### LIFE RAFT Sales & Service

**U.S.C.G. Approved Testing Facility**

- ★ U.S.C.G. life raft facility for Solas commercial yacht and fisherman rafts
- ★ COMAR DEBARKATION LADDERS
- ★ COMAR PILOT LADDERS
- ★ COMAR WORK LADDERS
- ★ All U.S.C.G. approved





**GUINNESS** "World's longest tested ladder 320ft."

Major Distributor for:







**IN SAN DIEGO CALL OCEANS WEST 619 544-1900**

# CHANGES

With reports this month from **Flamingo** on a 6,000-mile shakedown cruise from South Africa; from **Beach House** on diving in French Polynesia; from **Pacific Star** on cruising in Indonesia; from **Geja** on a third season of youth cruising in the Med; from **Mykonos** on a fifth Baja Bash; from **Curare** on a new 'marina' in Nicaragua; from **Serenity** on Mexico and Polynesia; from **Sealevel** on a Pacific crossing; and a generous portion of **Cruise Notes**.

## Flamingo — Knysna 480 Tim and Susan Mahoney South Africa to Grenada (Marin County)

As previously reported, we launched our new cat in South Africa on February 2, rigged her on the 3rd, and sailed her through the notoriously rough Knysna

Heads that afternoon for a test sail. We then returned to the marina for several weeks of final fitting out.

**Susan and Tim prior to their 6,000-mile shakedown sail across the Atlantic.**

It was good to have that time to test everything. We then had an exciting 350-mile sail to Cape Town, during which time we were able to further test the rig, steering and electronics. We did have a few issues, but we got them taken care of in Cape Town before setting sail for the 6,000-mile distant Caribbean on March 15.

We had strong winds and big seas the first 4½ days of our crossing. Fortunately, the 25- to 35-knot winds were blowing us toward our destination of St. Helena. We sailed conservatively, flying only the 580 sq. ft. genoa, and sometimes we even had that partially furled. We covered 920 miles in the 4½ days of that first leg, and hit a top speed of 19.6 knots while sailing down the face of a

**Inset; 'Flamingo' on the way to the water in South Africa. Spread; 'Flamingo' in purple and blue heaven, about to sail to St. Helena.**

big wave. *Flamingo* remained dry despite the rough conditions, and her stern rose to the following seas as though we were riding on a high speed elevator.

Tropical and fertile St. Helena, which can only be reached by boat, is a wonderful island. The locals, called 'Saints', were very friendly. We enjoyed a tour of the island, during which time we saw Napoleon's home and Jonathan the famous tortoise, and met several other cruisers while eating lunch at Anne's restaurant. It was a good break in the long crossing of the Atlantic. It also gave us a chance to stock up on food and fill our tanks before continuing on to Brazil.

The worst way to do a crossing, of course, is under the pressure of a deadline. But that's what we had, as we were under pressure to get to Grenada in time to fly to Seattle for our daughter's college graduation, as well as let our crew fly home. Naturally, we had very light winds once out of St. Helena, and trying to make westing toward Brazil without losing latitude was difficult. We continued northwest across the equator and through the ITCZ — but never picked up the famous 'Fortaleza 500' current off the coast of Brazil, which was supposed to help us so much. The only northbound current we did get was a few days south of French Guyana, but it was only two knots. We ended up stopping at Cayenne, French Guyana, to pick up fuel and drop off our crew for a flight home. That second leg took us 27 days.

Susan and I sailed the last leg to Grenada by ourselves. It was about 700 miles and pretty uneventful. The waves were a bit strange during part of this passage because it was often only 30 feet deep — even when we were 30 miles offshore. We finally pulled in to Clarke's Court Marina on Grenada with four days to spare on our deadline to fly to Seattle.

After three weeks back in the States, we returned to Grenada at the end of May. We're glad that our 45-day, 6,000-mile maiden voyage is over and we can now begin enjoying cruising in the Caribbean. It's hurricane season, of course, so we constantly check the



weather. If anything threatens, we're going to make a run south to Trinidad. Come November, we'll slowly work our way up the Antilles, then continue on to Miami, where *Flamingo* will be featured in February's Miami Boat Show. From there, we'll head south to Panama and work our way up to Mexico. At least that's the plan for now.

— susan 06/06/10

## Beach House — Switch 51 Cat Scott and Cindy Stolnitz Cruising Underwater (Marina del Rey)

It's funny that a bit of rain would deter us from diving more here at Maupiti, French Polynesia, even though the ocean is just as warm as the air and the rain is only slightly cooler. It's partly psychological. After all, it feels yucky when we have to don damp diving gear. Furthermore, everything below the surface looks monochromatic on rainy days.

The weather forecast for the next several days was for strong winds, which

COURTESY FLAMINGO



KYNSA CATAMARANS



# IN LATITUDES



ALL PHOTOS BY SCOTT STOLNITZ

*subbeachhouse.com* website — we think you'll like it!

We were happy when Ronald, the local dive guide, came along to pick us up for our dive, as it meant we'd likely be his last clients. He's selling his Maupiti Dive Center to another couple so he, his wife Michelle, and their two kids can buy a boat in Raiatea and go cruising.

The wind had shifted to the north overnight, which really knocked down the swell outside the reef. This was great, as it made for a much more comfortable ride to the dive sites. We had two wonderful dives. They were both in shallower water than the day before, so we were able to stay down a long time. Scott got some awesome detailed shots of the coral textures and patterns, colorful blue clams, and a jelly fish that looked to be from outer space.

We came across a few of the hated crown-of-thorns starfish, which destroy reefs. I could hear Ronald, in a Bruce Willis or Clint Eastwood voice, saying, "Not on my reef you don't!", as he went after them with a loose piece of sharp coral. He stabbed them, dismembered all their spiny legs, and strewed the remains with a certain amount of righteous indignation. If Scott was focused on shooting something with his camera for a while, Ronald would take the time to destroy more of this particular kind of starfish. Hopefully, Lionel, the new owner of the dive business, will keep up the practice.

We were so tired by the time we rinsed our gear, showered and had lunch, that it was nap time for me. While Scott looked

*Maupiti, one of the many gem-like atolls dotting the blue waters of the South Pacific. Divers know that it's equally dazzling below.*



*It's colorful above the surface as well as below in Polynesia.*

SCOTT STOLNITZ

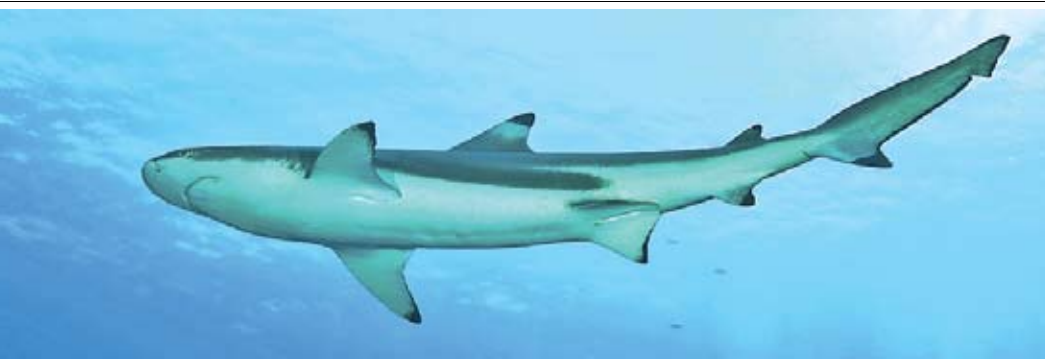

*Four bright reasons you would rather dive a coral reef in French Polynesia — or anywhere else — on a sunny rather than a cloudy day.*

meant we'd have some mandatory 'stay at home' days. It wasn't bad for Scott, who had a lot of video editing to catch up on. I have a harder time figuring out what to do, but I can always read. Although the rain cools the air — the lowest we've seen has been 76 degrees — it does get stuffy inside because we have to close all the ports and windows.

During the last two days of diving, Scott took close-ups of fish, coral and other things. He mostly used the wide-angle lens, which meant he wanted me in the photos for perspective. I'm pleased to discover that I didn't look as goofy as I did in my early days of underwater modeling, but it's still a challenge to look relaxed and not exhale when a photo is being taken. I benefitted from Scott's modeling tips — look at the camera or the subject; tilt my head up and raise my chest; avoid flailing my arms; and avoid super bent knees or widely spread

legs. I know how important good photos are to Scott, so I try to cooperate as best I can. Nonetheless, I was relieved when the batteries for the strobe died halfway through the second dive.

We later had a good time reviewing Scott's photos du jour. He got more good ones than I expected. I love his work, so I'm glad he has the patience for it. I certainly don't. I'm happy to point out pretty things for him to take photos of, but the experience would be ruined for me if I had to drag around the camera and other equipment. As I write this, he's in his 'darkroom'. Thanks to digital photography, all he needs is his Mac computer in plain daylight, not a dank room full of smelly chemicals as in the days of film.

We're having a blast finishing our new shark video, *Fins of Bora Bora*, for the web. We encourage people to visit the video gallery at our



AIR MAUPITI

# CHANGES

at our fish books to identify what we'd seen, my nap was delicious. When I woke up, it was almost happy hour and time for writing. It's a tough life, but somebody has to do it.

We were delighted when Jerome and Natalie on *Na Maka*, which is a blue-



**Cindy, modeling for Scott, with some beautiful coral.** hulled sistership to our Switch 51, anchored close to us. The other boats around are two other charter catamarans and a trimaran. Jerome and Natalie invited us aboard for dinner. It's always a treat to have someone else help with the cooking! When we arrived at their boat, Natalie was trying to get their three boys to finish their dinners. Natalie said any two of the boys get along fine, but there's always fighting when the three are together. What a brave woman to cruise with three children! But the family seems to really be enjoying themselves.

The next morning we dinghied to the fuel dock with five of our 5-gallon jugs. The day before, I'd "reserved" two dozen eggs, so I picked those up. I also bought vinegar from the walk-up window at the 'market'. The day before, the proprietor had let me inside to more closely view what he had for sale. Apparently, you can't always do this. I later bought two pamplemousse, which are like grapefruit, for \$3 U.S. each at a roadside stand. But there certainly isn't a Whole Foods or BevMo out here.

We were delighted to learn that both of Scott's packages had arrived in Papeete, and that the agent would have them on the plane arriving in Maupiti the next day. When they arrived, the first thing

**Is there anything more erotic-looking below the surface than the black and blue lips of the coral clam? Not to goths.**



SCOTT STOLNITZ

Scott planned to tackle is replacing the oil hose on the gen set. As for the new video lights, I prayed the new ones aren't lemons like the last ones were. It's unfortunate that companies don't seem to bench test their products before sending them to customers in far off places.

Well, our package of generator oil hoses and replacement video lights didn't arrive on the morning plane. Why? It was so full with passengers that they couldn't carry all the cargo, too. So they sent packages in alphabetical order. Unfortunately, our stuff was being sent to 'Yacht Beach House', not 'Beach House'. At least there was an afternoon plane.

It was interesting to watch the prop jet land on this narrow strip of motu in the middle of the South Pacific. There were a few people arriving, a few departing, and locals waiting for supplies coming in from Papeete. One of the B&B operators asked me if I had just arrived. In poor French, I explained that I was on a boat. Since one of his clients didn't arrive, he presented me with a fragrant welcome lei made from a string of tiara flowers. It's beautiful, and now hangs in our galley.

Scott couldn't wait to get to work on replacing the oil hose for the generator. It was a bit disconcerting, since the replacement hose was significantly smaller than the original leaky hose. But the fittings were the same size, and Scott had the foresight to have ordered extra fittings. We spent over two hours on the small project, he contorted in the awkwardly small space on top of our anchor line and chain, and me doing my best Vanna White impression, passing him various tools, shining the flashlight where necessary, and mopping up the endless drips of oil. Once done we tested it — and found that it still leaked! So we called it a night. The next morning Scott and Vanna attempted to fix the oil hose problem again. Although it then turned out that we didn't have enough fittings of the size we needed, we managed to make do, and it's no longer leaking. That's how it goes when you're cruising.

It's hard to believe, but we've been here in French Polynesia for almost exactly one year! If we could dive, I could happily stay here longer. If not, my feeling is that we might as



well move along.

I must be acclimatizing and/or the season must be changing, because I actually got cold standing out in the stiff breeze for two hours. I couldn't help laughing at my running inside to grab a sweater when the thermometer read 80 degrees! I later had a good workout scraping the 'hula skirt' of algae off the hulls. I felt cold by the end. No wonder, as the water temperature was all the way down to 81.4 degrees. Five days before it had still been 84 degrees at depth.

I must be settling into this life, because the days are just kind of gliding by. I hope to find some semblance of fresh vegetables soon, as I used my last carrot, broccoli and bell pepper today. I have a few apples, kiwis, and one grapefruit. After that, we'll be down to frozen peas and green beans. But no time to worry about that, as we're going to rent bikes for the one-hour circumnavigation of this atoll.

— cindy 05/28/10





*Spread; In a country with over 17,000 islands, it's only natural there will be lots of boats — including this 'megayacht' of sorts. Insets from left. Cart-pulling ponies are always dressed to the nines. The terraced rice paddies of Bali. Just one of about a million work boats.*

**Pacific Star — Island Packet 35  
Julia Shovein and Horst Wolff  
Indonesia  
(Emeryville)**

*[Continued from last month.]*

When you cruise Indonesia, you should bring the best camera you can buy and plenty of memory cards, because you'll see many colorful things you won't see many other places. Things like orangutans, Komodo dragons, Balinese dancers, verdant jungles, crocodiles, gorgeous birds, countless monkeys, talented weavers and wood-carvers, terraced rice fields, mounds of spices, exotic temples, dhows, vibrant colored pony carts, beautiful people, cute kids — "Take my photo!" they all say — and much more. At almost every anchorage we were greeted by people coming out in dugout canoes or boats powered by, in many cases, lawn mower engines. They

just wanted to say 'hello' or see if we wanted any of their goods or services.

With over 17,000 inhabited islands, there are countless places to stop in Indonesia. You could spend years cruising here; unfortunately, cruising permits and visas mean you only get a limited amount of time. Therefore, cruisers must compromise on what they want to see and do.

Cruising in Indonesia was quite different than in the other places we'd been before. For example, once we left Darwin, there wasn't really another marina until almost Singapore, a distance of thousands of miles. So we were thankful we'd gotten our windlass rebuilt prior to sailing to Indonesia, and that our Rocna anchor worked as

well as it did. Both got a real workout. We also found our AIS unit to be indispensable — especially at night. Having sailed the South Pacific, where we'd go for days on end without seeing another vessel, it was a shock to find so much traffic in Indonesian waters. After almost hitting an unlit barge, we started to do night watches together so we'd have an extra pair of eyes.

Navigation was also a challenge. The British Admiralty, American and Dutch charts are fairly accurate, but they are getting a little dated. C-map, the electronic charts most popular with cruisers, was usually pretty good, although they were up to a half-mile off at times. 'Eyeball navigation' became critical — another good reason for only traveling during the day — not just because of imperfections with the charts, but because there are almost no navigation markers or aids. Added to this are the incredible number of fishing traps and nets, small unlit fishing boats, shoals, reefs, rocks, and debris all along the way.

When we sailed out of Lovina Beach, Bali, at sunrise, we spotted a Swiss couple whose Ovni had got snagged on an old submerged bamboo fishing trap. We threw them a line and tried to pull them off, but weren't successful. Hearing our chatter on the radio, a couple of cruising boats with divers came out

**Facial expressions are important in Balinese dancing, which often portrays the battle between the good lion and the evil witch.**



**A Buddhist woman heads a load leaving a temple at Ubud, Bali.**



ALL PHOTOS COURTESY PACIFIC STAR

PACIFIC STAR

PACIFIC STAR

# CHANGES

to help. They were able to cut the ropes holding the cage together, and set the boat free. Needless to say, good binoculars are another must.

Weather, current and tide information was available from a variety of sources. The C-map NT+ cartridges have integrated information on local tides. The British 'TotalTide for Defense' program provides local currents as well as tidal information. Websites — e.g. <http://weather.noaa.gov/weather/current/VHHH.html> — provide weather and current information.

All cruisers depend on GRIB (GRIDded Binary) files via Winlink or Sailmail to monitor the development of major weather systems. However, these forecasts are neither reliable nor specific to local conditions. Jimmy Cornell's Noon-site is also helpful in identifying weather resources.

**Just like everywhere, the kids in Indonesia are cute.**

We used the VHF to check in with other cruising boats, and to share hazard warnings and other information. If we were getting beyond VHF range, we sometimes arranged informal nets with two or three other boats on the SSB radio to keep the information flowing. Email — via Winlink Airmail for us — often came in handy for communicating with boats up or down the line.

The weather in Indonesia was hot and dry, and this rarely changed until we neared the equator and got the usual squalls, thunder, and lightning storms. Prior to that, we rarely had strong winds. Typically it blew 5 to 15 knots from the

**A peaceful anchorage on the way between Romang and Flores Islands. Sailing conditions are generally mild in Indonesia.**

southeast, with seas between three and six feet. Our asymmetrical spinnaker on a broad reach was our favorite point of sail, followed by wing-on-wing when running downwind. We unfortunately had to motor more than we wished in order to maintain pace.

There were natural disasters — the Sumatra earthquake — while we were in Indonesia, and repairs from the '04 tsunami were ongoing. We were also around for human-induced disasters, such as the hotel bombing in Jakarta. Misfortunes of all types are not uncommon in this part of the world. Despite the foreign radical Islamic backlash to rapid development, globalization, and modernization, Indonesia is nonetheless a refreshing example of people living together in relative peace. One of our cab drivers in Bali explained that the races and religions generally get along, noting that he had siblings who had married into other religions, so his family celebrated both Muslim and Hindu holidays. Although the majority of the population of Indonesia is Muslim, Bali is almost all Hindu, and the people of Flores Island are predominantly Catholic.

Indonesia is not without grave environmental problems. We went on a two-day jungle boat trip in Borneo, and were picked up directly from our anchored boat in the Kumai River. We motored up a river — think African Queen — contaminated by mercury from the gold mines. The locals have to go far up that same river in order to find clean water. We spent the most heavenly day at Camp Leakey observing rehabilitated orangutan mothers and babies, and learned their habitat is under siege from proliferation of palm oil plantations.

When we returned to our boat, we were abruptly brought back to earth when we found rat excrement behind the locked companionway door. My husband, who uses denial as a coping mechanism, insisted we were seeing "gravel". He became a believer the next morning when there was a perfectly round hole in the entry way screen and half an apple in the galley with tiny teeth marks in it. It took a week, but a borrowed trap got the rat with only minimal damage to wiring and hoses. We were glad that we caught him so quickly, as we remembered that Canadians Jim and Diane of



*Prairie Oyster* were troubled by a rat for a full month in French Polynesia. They finally got him with a frying pan in the salon.

Indonesia was not an expensive country. Diesel fuel was only slightly less expensive than in the U.S., but everything else was much cheaper. A good meal in a restaurant — not available on smaller islands — was about \$3. At food stands, however, you could eat well for \$1. Our three-day trip to Ubud in inland Bali — which included a car, driver, a great hotel with pool, meals, and entertainment — cost us less than \$200 for two. It was often the case that we went days without spending any money because there was nowhere to spend it. Even items like food, postcards or T-shirts were generally not available at the national parks or other popular boating stops. We allot \$2,000 per month on average for all our expenses. In Indonesia, we came in well below budget. By the way, with one dollar bringing 10,000 rupiah, it was fun to be

PACIFIC STAR



PACIFIC STAR



# IN LATITUDES



COURTESY GEJA



*Scenes from last summer in the Med. Hide the children and non fun-loving young women of the Adriatic and Ionian Seas, for Andrew Vik is back with his Islander 36 'Geja' and band of merry friends. Having left the boat in Croatia for the winter, that's where this year's adventure starts.*

millionaires!

The best advice we can share about sailing central Indonesia is there are 'no worries' if you have a good boat. Everyone will make their own experience. Don't be deterred by rumors. Besides the occasional normal gear failures in the rally fleet, we have no negative tales to tell. The friendliness and hospitality of the people is offered openly and warmly. The beauty of the land, the beaches, and the incredible diving locations available are unsurpassed. Indonesia, so rich in coastline, was made for those who like to explore the world by cruising.

— julia 04/15/10

## Geja — Islander 36

Andrew Vik

Third Summer In The Med  
(San Francisco)

Greetings from the sweltering heat

of Croatia. I left San Francisco for my boat in Split, Croatia, around the 10th of June. Prepping *Geja*, the '76 Islander 36 I bought through an ad in *Lectronic*, for my third summer of cruising in the Med went smoothly. In fact, I've already spent two nights out in the super-charming islands of the nearby Dalmatian Coast. I've got almost 20 people — mostly friends and acquaintances from the Nordic countries — lined up to join this year's cruise of the Adriatic and Ionian seas. I'm sure I'll have plenty of photos and tales to share from along the way.

— andrew 06/20/10

Mykonos — Swan 44  
Marina and Myron Eisen-  
zimmer

Bash #5  
(San Geronimo)

Seventeen days after leaving Cabo San Lucas, we completed our fifth Baja Bash from Cabo to San Diego. We started by clawing our way north, stopping at Bahía Santa Maria, Punta Abreojos, and Asunción. Realizing how much fuel we'd burned by the time we got to Asunción, we went ashore and flagged down Jesús, a fisherman, who offered us a ride to town. He then drove us around in search of diesel. Fishermen belong to different cooperatives and have different diesel supplies. His cooperative was out of fuel, so Jesús directed us — "go through the yellow door and turn right" — to the other cooperative's office. They had lots of diesel and were willing to sell it. Once we got fuel, Jesus drove us back to the beach and then gave us a ride back to *Mykonos*.

That night we took off for Turtle Bay. The plan was to get fuel and water, then leave a few days later. But then Amigo Net weather guru Don Anderson gave a forecast for horrible conditions — and seemed to take joy in it — with gale force wind. For 10 days we had to wait in Turtle Bay for better conditions! During this time, we watched some boats head north anyway, then have to limp back in. And while listening to Channel 16, we heard the story of a powerboat that blew out a window around Cedros, and another one that broke the bracket that held its dinghy on deck.

*Strolling out Turtle Bay's pier is fun, but 10 days of it might be too much of a good thing — especially when you really want to get north.*



COURTESY MYKONOS



LATITUDE/NICK

# CHANGES

While Turtle Bay is a great place to hang out, there is no ATM, and none of the businesses take credit cards. The captain of one large boat actually had to have money wired to him so his crew could eat.

After the 10 days, we were part of a flotilla of six boats that headed north. Getting past Cedros Island was unnerving, as *Mykonos* pounded for the first 24 hours, with waves flying into the cockpit. After a while, our chartplotter had enough and quit, so we went back to making fixes on paper charts. At 3 a.m. on the second day, the wind finally dropped to 7 knots and the sea flattened. The next morning, Memorial Day, we crossed the border back into the U.S.

We've done four other Bashes, all of which took between 7 and 10 days. This was our most difficult, even though 10 of the 17 days were spent waiting for better weather in Turtle Bay.

— marina 06/05/10

## **Curare — Bowman 36 Geoff and Linda Goodall Corinto, Nicaragua (Vancouver, Canada)**

After leaving El Salvador, we spent some time in the Golfo de Fonseca — which is bordered by El Salvador, Nicaragua and Honduras — before sailing overnight to arrive at the port town of Corinto, Nicaragua. This is the main port for Nicaragua, as well as a major transportation hub to other destinations in Central America such as Honduras and Costa Rica. The Spanish established a port near here in 1532, and it's been in continuous use ever since.

*Up a lazy Nicaraguan estuary, with officials from the Ministry of Transportation, Immigration, and Customs, and Linda at the helm.*



CURARE

Entrance into the port is straightforward and well-marked with ocean buoys, channel markers, and range-markers. Excellent information is provided by [www.sailsarana.com](http://www.sailsarana.com). The port area itself is well-protected from any swell off the Pacific, as it lies behind a barrier island. The port hosts a container terminal, a fuel storage farm and a pocket cruise ship terminal. The port sees two to six ships a week, plus random cruising boats such as ours.

Upon clearing the channel markers, we motored past the container port and anchored just beyond the floating power generation plant. This area is at the entrance of the estuary that leads northwest and northeast. With all of the ship traffic, plus the noise and pollution from the diesel-powered generating station, we had previously decided to stay farther upstream at the relatively new Corinto Marina in the Paso Caballo Estuary. After unsuccessful attempts to raise the port captain on 16, Ivan Aguilar, the owner of the marina, hailed us to report that he'd arranged for the authorities to come out to inspect *Curare*.

Corinto Marina is located three miles beyond the Corinto port, in a well-protected and quiet estuary. To get to the marina, you pass by the Nicaragua Naval Base, which has heavy security and is well-patrolled. Before you transit past the base, permission must be obtained. With our limited Spanish, it was beneficial that Ivan made the arrangements for us. So while Geoff showed the port captain, a representative of the Ministry of Transportation and Infrastructure, and an Immigration officer around *Curare*, Linda motored the boat up to the marina. By the time we arrived, all of the paperwork was complete, and Ivan took the officers away in his boat.

Immigration had required a copy of our international *zarpe*, passports, and \$5 each, plus \$15 for the boat. The Port Captain got the original of our *zarpe*, copies of our ship's registration certificate, plus copies of our passports. He also conducted a very cursory inspection of our boat while he enjoyed a Coke. The Transportation official required a copy of our ship's registration certificate, copies of our passports, and \$25 for a three-month cruising permit. This last item is new, and we had the honour of being the first vessel to have to pay the fee in Corinto, as well as being the first boat to deliver the officials to the Corinto Marina.

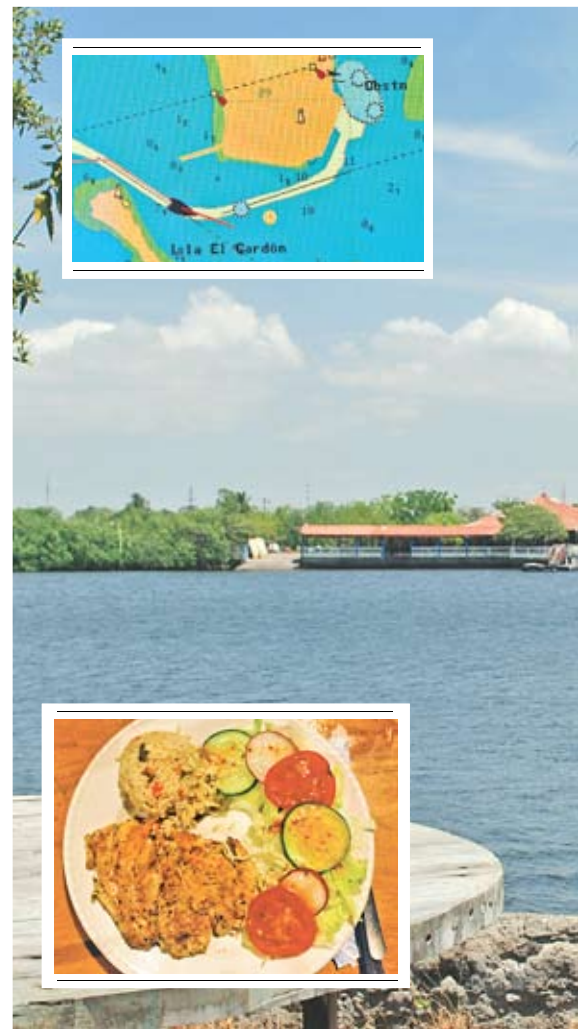

The Corinto Marina ([www.corintomarina.com](http://www.corintomarina.com)) is not your typical marina in the fashion of Barillas Marina in El Salvador or Puesta del Sol Marina in Nicaragua, but it does provide a place to stop in a protected area in order to provision and tour inland. The anchorage is clean, there is good holding, it's well protected from the wind, there is no swell, and it's relatively secure. The marina has the added benefit of a small dinghy dock, lots of clean water for washing, laundry service, the use of the 'clubhouse', plus security provided 24/7 by a watchman. The clubhouse is an air-conditioned building on stilts above the estuary, where you can take showers, plug in your computer, watch TV, and relax in the screened-in porch. Ivan intends to provide further services for cruisers in the future.

Despite the fact that Corinto Marina is very rustic, for \$5/day we were able to confidently leave our boat in a very secure location for a few days so we could visit the colonial cities of Nicaragua. The

# IN LATITUDES



ALL PHOTOS CURARE

**Spread; The anchorage off the Corinto 'Marina'. Insets; The entrance to the port of Corinto isn't too hard, and the food is inexpensive.**

charming town of Corinto is four miles away and can easily be reached by taxi for \$1.50 U.S. or bus for 50 cents. Aside from the touristy attractions, Corinto has a couple of internet places and a fairly well-stocked grocery store. The town of Chinadenga is nine miles to the north, and is easily reached by a 50-cent bus ride. It has several banks, a large grocery store and markets, plus buses to Leon (30 miles for \$1 U.S., Managua or Tegucigulpa, Honduras. We rented a car in Chinadenga and toured the country for a few days. It was great fun — except for a traffic police incident and some minor civil unrest in Granada.

Nicaragua is a very poor country, but has clean water, good roads and reliable power. We found it to be less expensive than El Salvador, with a sit-down lunch of fried chicken, rice, beans, salad and tortilla washed down with a cold beer costing \$3.50. A more-than-you-can-eat

dinner of grilled steak, *gallo pinto* (mixed red beans and rice), cheese and tortilla cost 17 *cordoba* — or roughly \$8.

As I write this, it's the start of the hot and wet summer season. The daytime temperature is 95 degrees and the humidity is 80 to 95%. Thus you can understand that our plan is to continue on to Costa Rica, then make the jump to Ecuador, where the weather is reputed to be spring-like, with no hurricanes or lightning storms and less heat and humidity.

*geoff and linda/6/10*

## **Serenity — Tayana 52 Gordon and Sherry Cornett Mexico and Polynesia (Ventura)**

After surviving the '09 Ha-Ha, we sailed up into the Sea of Cortez as far as north as Puerto Escondido. We really enjoyed the Sea. Our favorite stops were La Paz, where we were able to swim with the whale sharks off the *mogote*, Caleta Partida, Isla San Francisco, San Evaristo, Los Gatos, Agua

Verde and Puerto Escondido. Wait a minute — that means we enjoyed every place we visited!

We had a fast crossing of the Sea to Mazatlan, and just before landfall had 12 AIS targets within the 48-mile radius. What a freeway! Mazatlan was a blast, and the *malecon* and Machado Plaza are not to be missed. With our boat secure in Mazatlan, we took a trip on *El Chepe*, the slow train, to Copper Canyon. It was a lifetime experi-

ence. After returning to our boat, we sailed down to the bird reserve at Isla Isabel, where we were treated to the sight of over 100 humpback whales playing around the island. At about 3 a.m. one morning, we were awakened by the sound of a whale exhaling right next to our anchored boat. It was very exciting.

We prepared for our Puddle Jump in Puerto Vallarta, and finally set out for French Polynesia on March 20. We had some fast days, some slow days, some squally days, some very hot days — but what we never had in three weeks were any boring days. The only problem we had was a ripped main, but that was our own fault. Everything else worked fine.

While in the Marquesas, we visited Hiva Oa, Fatu Hiva, Tahuata, Ua Pou and Nuku Hiva. We then followed the route recommended by Steve Van Slyke of the Gig Harbor, Washington-based *Kavenga*, which meant we visited the north shore of Hiva Oa, giving us a good sailing angle for all the other islands we visited.

Our best experience in the Marquesas? As we dinghied back to our boat one moonlit night in the Bay of Virgins,

***If you're looking for contrasts in cruising, few are as extreme as that between the desert-like Sea of Cortez and the lush Marquesas.***



LATITUDE/RICHARD

***Mazatlan is all but Spanish for 'shrimp'.***



MOONSHADOW

# CHANGES

Fatu Hiva, some young men were playing ukuleles and guitars, and singing Marquesan songs. We drifted silently, listening to the harmonies, as clouds periodically obscured the moon that seemed to be sitting behind the spires backing the bay. It was magical.

LATTITUDE/RICHARD



**No question about it, it's baguettes that put the 'French' in French Polynesia.**

We're currently at anchor in the lagoon of Manihi atoll, waiting for the rain to stop so we can set off for Rangiroa. We've already traded for pearls and done a pass dive here with Fernando. He's a baker who became our local friend when he showed up at our boat one morning — despite the pouring rain — with free baguettes that were so fresh they were still warm.

As we say, just another lousy day in paradise. I'd write more, but I have to light the BBQ to cook the yellow fin tuna we just caught. How was your day?

— *gordon & sherry 06/10/10*

## **Sealevel — Schionning 49 Jim and Kent Milski Puddle Jump (Lake City, Colorado)**

We only ran our engine for 24 hours in our 18-day crossing from Zihua to the Marquesas. We probably could have gone faster, but we double-reefed the main for 75% of the crossing. We also wasted a day when I thought I saw a distress flare and we conducted our very own SAR operation. Fortunately, the folks on *Freezing Rain* had seen it, too, and explained that it had actually been an exploding meteorite.

The highest winds we saw were 28 knots, and our fastest speed over ground

**Because 'Sealevel' is such a powerful cat, Jim and Kent wisely kept her double-reefed for much of the crossing to the Marquesas.**

was 14 knots. We could have gone faster at times, but as you increase speed, you decrease comfort. The question on any crossing is not how fast you get there, but how happy the crew is during the passage and when you arrive, and how many — or how few — things you break. We had a wonderful crew, played a lot of cribbage, and had a lot of laughs.

The highlights of our trip? SailMail, which is fabulous. Jicama was our MVV, or most valuable vegetable, although apples, carrots, oranges, cabbage and onions also stayed fresh all the way across. The worst part of the trip was my having to go up the mast several times because of a parted spinnaker halyard. That's never fun at sea.

We're currently at the south end of Fakarava in the Tuamotos. The diving is fabulous. The surf is also very good, but unfortunately it's not a sand bottom. While I was surfing yesterday with friend Steve May of the Gualala-based Corsair 41 cat *Endless Summer*, my board came back up through the wave and caught me right on the bridge of the nose. It wasn't good, as there was lots of blood in the sharky waters, but everything turned out all right. Kim on *Victoria* is a physician's assistant, and fixed me right up, while Adam on *Elena*, a pharmacist from Holland, supplied me with some pain killers. There's nothing like the cruising community! The worst part was the long paddle back to the dinghy.

The pamplemousse — Polynesian grapefruit — we'd had in the Marquesas was the best ever. It's sweet and juicy, so we should have bought lots more. Breadfruit trees here look like magnificent Matisse paintings, and the neon fish and turquoise coral forests are mesmerizing. I'm even almost used to the black-tipped reef sharks — which are everywhere!

We plan to be in Tahiti for the Rendezvous, where we'll be joined by friends Wayne Hendryx and Carol Baggerly of the Brisbane-based Hughes 45 *Capricorn Cat*.

— *jim and kent*

## **Cruise Notes:**

In early June, Greg Dorland of the Lake Tahoe-based Catana 52 **Escapade**, who along with his wife Debbie Macrorie had done the Ha-Ha, transited the Canal, then sailed across the Caribbean to take cruising cat honors in the inaugural Voiles de St. Barth, suffered a badly



broken leg while sailing into Annapolis. Dorland tells how it happened:

"Debbie and I were about 10 miles out when we came up on a close reach to avoid some lightning. Steering from the leeward side, I saw a huge puff headed right at us, so I jumped down to release the genoa sheet, which was really loading up. Unfortunately, the sheet spun out of control, wrapped around my leg, and snapped it in two in a bloody compound fracture. Debbie somehow managed to get the sails down, called the Coast Guard, and give me some pain pills — which had zero effect. The Coast Guard arrived with a couple of inexperienced medical people, who wanted to make a splint out of an orange life vest. No way! Annapolis Fire Boat #35 then showed up with some real paramedics, who gave me some morphine, strapped me down to a backboard, then transferred me to the fire boat. Thank you, thank you, thank you! But the situation was far from over, as the Coasties hadn't noticed that we'd drifted into the shipping lane and were about to be run down by a tanker. The

HEATHER CORSARO



# IN LATITUDES



SPREAD PHOTO LATITUDE/NICK. INSET PHOTO DEBBIE MACROIRIE

**Spread; Craig and Howard Shaw aboard the Columbia 43 that's been in the family for over 25 years. Inset, Greg Dorland's broken leg.**

guys on the fireboat were scared, so they quickly got away from *Escapade*. That left Debbie and the two Coasties on the cat, about to get run down. In the end, the tanker missed them by a reported 25 yards. There was a Coast Guard boat standing by the whole time, so I don't know why they weren't aware that a dangerous situation had developed. Once Debbie started our one good engine — all the Volvo dealers have been out of a common but critical engine part — the Coast Guard left her to her own devices. She had to continue on to Annapolis, a strange port for her, with one engine, and then anchor with one engine. Fortunately, Kristen and Bob Beltarano, having heard our distress call, called Debbie on her cell phone and gave her the number of a friend in Annapolis who could talk her into an anchorage. I have a leg full of metal and pain, but what about Debbie's day!"

Nearly a month later, Dorland reports

he and Debbie are living at a Residence Inn in Annapolis, and it will be another month before he can fly because of the fear of blood clots. It will be three months more before he can put any weight on the leg. "We hope to spend July and August in Tahoe, and hopefully can be back on the boat full-time again in September. As much as we appreciated how fortunate we've been to be able to cruise as we have, and meet all the wonderful people we have, we appreciate it now more than ever. But the Wanderer was right, we never should have left St. Barth!"

The **Baja Bash**, meaning the 750-mile upwind trip from Cabo to San Diego, can be a nasty one. If you don't get a weather break, it can mean an upwind slog in 15 to 25 knots of wind. And unlike the fall, when cruisers head south along the coast of Baja, the Pacific Coast of Baja is cold in the spring and early summer. In late May, Craig Shaw of the Portland-based Columbia 43 **Adios** was about to begin a singlehanded Bash. A rigger and

fine sailor, Shaw knows his stuff. But when Howard, Craig's 82-year old father, learned of Craig's plans, he signed himself on as crew. It wasn't as though Howard needed to be told about the boat, for he owned it before he sold it to his son. And on the way to San Francisco from Portland for the start of the '88 Pacific Cup, Howard and crew got blasted by 60 knots winds at the Oregon - California border. "We hit

17 knots," he remembers. "We managed to get the main down, which we needed to do because it was the original main and we had to have it for the Hawaii race. Nonetheless, with the anemometer pegged at 48 knots, we sailed at a sustained 12 knots under a low-hoist 130 genoa. I locked my wife, grandson and other crew down below — it's the only time I've done that — and another guy and I stayed out in the cockpit, taking turns sleeping on the cockpit sole. The blow lasted almost to Bodega Bay, where we pulled in and I got the best night's sleep ever." After doing the Pacific Cup, Howard and his wife spent six months living on *Adios* in Hawaii. The following June, with son Craig and a 747 pilot along as crew, Howard sailed the boat back to Portland. "Early June was a little too early to leave," laughs Craig, "because we really got hit. With sustained winds of nearly 50 knots, we were doing nearly 15 knots with just a small headsail." But those rough bits didn't put Howard or Craig off sailing. In fact, Howard sold Craig the Columbia 43 so he could buy the Hunter 54 **Camelot**, a faster downwind boat, to do another

**The antique Electrolog instruments on 'Adios' — seen above and below — managed to survive yet another Baja Bash.**



LATITUDE/NICK



LATITUDE/NICK

# CHANGES

Pacific Cup.

Howard is in fine shape mentally and physically, no doubt in a large part because he stays so active. In addition to sailing, he golfs on Mondays, Wednesdays and Fridays, and plays tennis on Tuesdays and Thursdays. Anyway, Craig and Howard left Cabo for San Diego on May 31, Howard's 82nd birthday. As Bashes go, they didn't have a particularly bad one. In fact, they arrived in San Diego only 6.5 days later, and that was without pressing. "The Bash made dad think about bringing his own boat down in the Ha-Ha this fall," says Craig. "Why not?" laughs Howard. "I really enjoyed myself when I came down to join Craig for the Banderas Bay Regatta. Besides, I just put a new engine in the Hunter." As for Craig, he'll be doing the Ha-Ha again for sure. Who knows, maybe they'll be the first father-son team to each enter his own boat.

According to Chris Landsea of the National Oceanic and Atmospheric Administration, there is some good news and some bad news about the **effect of climate change on hurricanes/typhoons**.



HURRICANE WATCH

**'Ivan', which hit Grenada in September of '04, was the last hurricane to really devastate a sailing fleet in the Eastern Caribbean.**

Saying their knowledge of the subject has increased tremendously in the last two years, Landsea reports that by the end of the century people can expect there to be between 6 and 34% fewer storms, but

that the overall strength of the storms will increase by 2 to 11%. Unfortunately, an 11% increase in windspeed translates to a roughly 60% increase in damage, so the bad news outweighs the good.

We hate to be skeptical, but with the climate in such an apparent state of flux, how valid can hurricane/typhoon forecasting be some 90 years out? We'd be happy if NOAA could come up with a reasonable forecast just four months out. As most mariners know, unusually warm water is the primary reason forecasters say they are calling for **an active hurricane season** in the Atlantic/Caribbean this summer and fall. The last couple of years have seen marine interests in the Atlantic and Caribbean come away relatively unscathed.

"After 'racing' around the world single-handed in 10 months and 20 days, and thinking about following it up with an eastabout circumnavigation, I've decided to slow down and smell the spices," reports Mike Harker of the Manhattan Beach-based Hunter 49 **Wanderlust III**. "So I'm now down in Grenada, 'is-

Come to Mexico and repair your boat at

## OPEQUIMAR

MARINE CENTER CENTRO MARINO

Puerto Vallarta

**88-ton (max) Travelift!**  
Length to 100'  
Width to 23'

México AEROTRON www.aerotron.com RIVIERA NAYARIT El Paraíso del Pacífico Mexicano PUERTO VALLARTA Where Mexico Comes to Life

[www.opequimar.com](http://www.opequimar.com)

fuel dock • full service boatyard • brokerage • 88-ton Travelift

## DISCOVER WHAT CRUISERS HAVE LEARNED

To outfit your Blue Water Adventure, go to **DOWNWIND MARINE**  
The Cruiser's Chandlery, where you will find extensive experience and great value!

Official Sponsor  
2010  
BAJA  
HA-HA

## THREE STORES TO SERVE YOU

All with Online Convenience!



THE CRUISER'S CHANDLERY

[www.downwindmarine.com](http://www.downwindmarine.com)

2804 Cañon Street  
San Diego, CA 92106  
(619) 224-2733  
(866) 289-0242



[www.sandiegomarine.com](http://www.sandiegomarine.com)

2636 Shelter Island Drive  
San Diego  
(619) 223-7159  
(800) 336-SDMX  
Mexico 001-800-336-7369



[www.sailingsupply.com](http://www.sailingsupply.com)

2822 Cañon Street  
San Diego, CA 92106  
(619) 225-9411  
(800) 532-3831

We are a great family of marine stores with even more service, websites, and resources to meet all of your boating needs.



land of the spices', to be outside of the hurricane belt for what many predict will be a very active hurricane season in the Atlantic and Caribbean. Grenada is where I had my terrible hang gliding accident in April '77 that resulted in my spending 11 months in a coma, two years in a hospital bed, and three years in a wheelchair before I was able to walk again. But the Grenadians saved my life, and I have many friends here. I will also visit friends in Isla Margarita and Los Roques in Venezuelan waters until November, at which point I will either return to Antigua and St. Martin, or join my friends and sail down to Brazil, then across to their home in Knysna, South Africa. I will make that decision when it is time. That is the beauty of being retired, having lots of free time and owning a very good sailboat."

Harker also tells us that in order to escape the heat and humidity of the Caribbean for a bit, he accepted an invitation from the World Hang Gliding Championship folks to attend their event in the Bavarian Alps. He even decided to get

into a hang glider again for the first time since his accident, flying down from Tegelberg Mountain and around King Ludwig's famous Neuschwanstein castle. Harker also keeps a Harley at the beautiful Bavarian resort town of Garmisch-Partenkirchen, and enjoyed riding over the 10,000-ft high summit of Pash H in the Austrian Alps.

As for the idea of sailing from the Caribbean to Brazil, we'd have to suggest that Harker talk to Mark Schrader, who just completed the Around the America voyage with Dave Logan, Herb McCormick and David Thoreson aboard the 54-ft **Ocean Watch**. A two-time singlehanded 'round-the-world racer, Schrader told us that the worst part of their trip was sailing from



**Oh no! To take a break from the heat of the Caribbean, Harker traveled to Bavaria to mess with small aircraft and ride his Harley.**

the Caribbean down the coast to Brazil, as it pitted them against a current that ran as strong as five knots. That's the reason that grizzled cruisers who want to sail from the Caribbean to Brazil often do so by way of Europe. Sure, it's much longer, but they get the wind at their back and favorable current almost the

**New Member Showers and Laundry Facilities Now Open!**

**NEW SLIPS!**  
Now taking reservations for 40' to 60'

## Emeryville Marina

ON THE BAY

When you call Emeryville Marina Home...  
...call this your backyard!

**Free Wi-Fi and Video Surveillance**

**Slips from 20-65 ft**  
**Full Amenities - including Fuel Dock & Pumpout Station**

**(510) 654-3716**  
[www.emeryvillemarina.com](http://www.emeryvillemarina.com)

# CHANGES

entire way.

It was way back in '03 that the Boulder City, Colorado family of Chay, Catherine and then-six-year-old Jamie entered the Ha-Ha with their Kelly-Peterson 46 **Esprit**. While they have taken breaks, such as leaving the boat in Darwin, Australia for the last six months, they just keep going. In fact, they are returning to Darwin to get the boat ready for the July 24 start of the Sail Indonesia event, to be followed by adventures in Singapore, Malaysia and Thailand. As for Jamie, the proud parents report, "He just turned 13 and graduated from 8th grade with two high school credits. He also earned his leadership collar in karate, having taught over 500 classes, and is close to earning his 3rd degree black belt. And on the boat, he's pretty much a full crewmember."

Speaking of **Sail Indonesia**, Nancy Potter Tompkins reports that she and husband Commodore, currently in Australia aboard their Wylie 38+ **Flashgirl**, will be joining Randy Repass and his wife Sally-Christine for that rally aboard the West Marine founder's Wylie 65 **Convergence**.

"We did a month with my Casamance



ESCAPADE

**He delivers! While Colon is indeed a notorious armpit, it's hard to fault this floating fruit and veggie market at the nearby San Blas Islands.**

47 catamaran **Viva!** in Cuba, a few weeks in Jamaica, a bit in Isla Providencia, then sailed south to Boca del Toro, Panama," reports Bob Willmann who has been on boats so long he can't really call Golden,

Colorado, home anymore. "I'm now moving eastward on the Caribbean side of Panama, and will probably get to the San Blas in a few days, and then Cartagena by the end of July. I'll send *Latitude* a report on Cuba, complete with photos, but not until August, as there just aren't very many internet cafes in places where a normal person would want to be. Where we are now, the aptly named Colon, is a case in point!"

Have American boats been returning to **Cuba**? Yes, they have — although not yet in the numbers of the Clinton Administration years. Almost everybody is betting it's safe to return to Isla Fidel because the Obama Administration is not going to have the Treasury Department prosecute anyone for so-called 'trading with the enemy'.

"Now that was one tough voyage!" writes Ray Jason of the San Francisco-based Farallon 30 **Aventura**. "I don't know what wind god I offended to deserve such punishment, but apparently it was decreed that I should be made to sail without any wind. I'm now safely at Port Antonio, Jamaica, rather than Carta-

## TRAVELERS AND RACERS PACKAGE

\$179.

INCLUDES SUITE & SLIP!

COME TO THE BEST HOTEL AND MARINA IN ENSENADA, MEXICO

Dock in a 45' slip, stay in a standard suite and enjoy all the hotel services: Outdoor and indoor pools, Jacuzzis, SPA, sushi bar, international cuisine Restaurant, free wireless internet, Mexican-Art Store and much more.

OFFER EXPIRES ON DECEMBER 31<sup>ST</sup>, 2010.

CALL TOLL FREE NOW TO RESERVE.

FOLLOW US IN:

HOTEL CORAL AND MARINA

**1 (866) 302-0066** | VHF 71 | [fito.espinoza@hotelcoral.com](mailto:fito.espinoza@hotelcoral.com) | [www.hotelcoral.com](http://www.hotelcoral.com)

## Ventura Harbor Boatyard

Located halfway between San Francisco and San Diego

Official Sponsor

2010  
BAJA  
HA-HA

OPEN SATURDAYS

Two Travelifts

- Haul-outs to 160 Tons
- Painting
- Rigging
- Machining
- Welding
- Electrical
- Sandblasting
- Woodwork
- Chandlery
- Custom Stainless

1415 Spinnaker Drive, Ventura, CA 93001

(805) 654-1433 • [www.vhby.com](http://www.vhby.com)

gena, Colombia. It took me 17 miserable days to get here. Since it's only about 700 miles, that means I averaged only about 40 miles a day. In the Caribbean! *Aventura* normally knocks out 100 miles a day, but there was just no damn wind. The few times there was a little wind, it was right on the nose. Every experienced sailor will tell you that light air sailing is much more nerve-wracking than heavy weather sailing. With the latter, you normally reef down, go below, and let the windvane handle the steering. With zephyr sailing, you have to try to coax every possible mile out of the breeze. This often involves having the sails up without enough wind to keep them filled, so they slam around and put tremendous strain on the rigging. It always feels as if the next jolt will bring the mast down. And did I mention the heat inside the boat? As always, *Aventura* performed magnificently. There were two nasty moments. The first was my first encounter with a white squall, where the wind went from 0 to 60 knots in 90 seconds. It spun my boat like a top. The second was a close encounter with a tramp steamer. I was

becalmed and couldn't get out of the steamer's way, and it only missed me by 100 feet. I called them on the radio, shone my spotlight on them, sounded my air horn, turned on the strobe light — and they still managed to not see me! Anyway, I'm safe and in good spirits. After a few days to recover in Jamaica, I'll continue on to Cartagena."

**Inflatable surfboards?** Yep, participants in previous Ha-Ha's have used them to surf Bahía Santa María, and thought they weren't that bad. But **inflatable SUPs** — meaning stand-up paddle surfboard/paddleboards? We bought an Uli 15-footer, which is way more a paddleboard than a surfboard, to use in the Caribbean for the month of May, and can report that it had some



**While inflatable surfboards and SUPs may not perform as well as traditional ones of fiberglass, they do have big advantages on boats.**

distinct advantages over traditional fiberglass boards and SUPs. 1) We could roll it up and fly with it as normal baggage. 2) While the awkwardly large SUPs seem to bang and ding everything, an inflatable SUP is like banging into something with an inner tube. It makes it soooo much easier to get on and off the boat.



## SAN FRANCISCO BOAT WORKS

835 Terry A. François St., San Francisco, CA 94158  
(415) 626-3275 Fax (415) 626-9172

- *Let us give your boat a fresh shave and haircut!*
- *Have lunch on us at the Ramp Restaurant!\**
- *Walk to a Giants game!*
- *Shop in our Chandlery!*

[www.sfboatworks.com](http://www.sfboatworks.com) info@sfboatworks.net



So close...  
*you could swim over!*

**DISCOUNTS?  
ASK US!**



*\*Some restrictions apply*

# CHANGES

3) On several occasions we used the Uli SUP as a two-person inflatable for going between the boat and shore. It wasn't bad — at least in the tropics. 4) If you bang your head with an inflatable board while surfing, you're not going to be hurt or bleed. When it comes to surfing, it was super easy to catch waves because the 15-footer paddled like a rocketship. On the other hand, it was way too long and thick to be very maneuverable. But surfing legend Gerry Lopez liked the Uli concept so much, he's 'shaped' some much shorter ones for the company to add to their line. Uli boards are more expensive than those made by Sevylor. One of the reasons is that Uli uses better pumps and valves, so you can get up to nearly 20 psi — which makes the board pretty stiff. Inflatables may not be the ultimate in surfboard and SUP performance, but they do have some advantages. We hope to have the *Latitude* Uli on hand for trial at the Delta Doo-Dah later this summer and during the Ha-Ha this fall. We hope you'll check it out.

Congratulations are due the World Cruising Club of England for filling all



While George Backhus, seen with his sweetheart Merima, didn't do the first ARC 25 years ago, his *Deerfoot 62 'Moonshadow'* did.

225 positions in the **25th annual Atlantic Rally for Cruisers (ARC)** three months earlier than in any previous year. The ARC, of course, is the granddaddy of all cruising rallies, and the fleet will de-

part the Canary Islands on November 21 for the 2,700-mile passage to St. Lucia in the Eastern Caribbean. Having done the 10th edition of the ARC on our Ocean 71 **Big O**, we can tell you that thanks to the typically warm weather and following tradewinds, it's normally one of the most pleasant passages in the world of sailing. Thanks to the double whammy of a weak global economy and what had been a poor dollar-to-euro exchange rate, the number of American entries is just 10. Nonetheless, the American contingent will be headed by George Backhus and Merima Dzaferi on the Sausalito-based *Deerfoot 62 Moonshadow*, because *Moonshadow* is one of two entries that also did the original rally 25 years ago — although not under Backhus' ownership. The other American entries are: **Bambochip**, Pierre Bausset's Shipman Seaway 80; **Glass Slipper**, John Martin's Moody 46; another **Glass Slipper**, Thomas Carbaugh's Oyster 53; **Herceg-Nov**, Nikola Kovilic's Roberts 58; **Noble**, John Noble's Oyster 655; **Oceanica**, George Champion's Jeanneau Sun Odyssey 52.2;



IT'S ALL ABOUT POWER.



INFLATABLES



INFLATABLES





HONDA MARINE  
IT'S ALL ABOUT POWER.





**We've been THE Bay Area authority for inflatables and outboards for more than 35 years.**

Call us today for quotes.

**Voyager Marine**

1296 State St.  
P.O. Box 246, Alviso, CA 95002-0246  
**(408) 263-7633 • (800) 700-7633**  
Open Tuesday thru Saturday



Your secret paradise...



in  
*Nicaragua*

Located in a beautiful sheltered lagoon on the north Pacific coast of Nicaragua, Marina Puesta del Sol is your premier cruising destination in Central America.



*Marina Puesta del Sol*

RESORT

Aserradores, Nicaragua ♦ 011 (from US and Canada) 505-880-0019  
mpuestadelSol@yahoo.com ♦ www.marinapuestadelSol.com ♦ USA 408-588-0017

**Phaedo**, Paul Hand's Gunboat 66; and **Time Warp**, Peter Nelson's Jeanneau Sun Odyssey 45.2. And somehow, Steve Dashew, known for having designed the Deerfoots, has been allowed to enter with his FPR 83 **Wild Horse** motoryacht. For those with inquiring minds, the ARC is open to boats between 27 and 85 feet. The entry fee ranges between \$975 and \$1,700, not counting crew. While that is three to five times as expensive as the Ha-Ha, it should be noted that the ARC provides extensive pre-rally seminars of all types, plus many pre-and post-rally social activities. The fact that the rally sells out every year is a testimony to the fact that participants feel they are getting good value for their money.

We always love scanning entry lists for interesting boat names. In the case of the ARC, we like **Spirit of Lusitania**, a Beneteau 57 owned by Joaquim Fortunato. Curious as to why someone would name their boat after the Cunard ocean liner sunk off Old Head of Kinsale in 1915 by a German U-boat, with the loss of 1,200 civilian lives, we did a little

research. It turns out that Lusitania was also an ancient Roman province that included all of Portugal south of the Douro River — making it a perfect name for one of the few Portuguese entries.

The folks at the World Cruising Club would also like you to know they will be hosting another **World ARC**, which is a 25,000-mile circumnavigation to be completed in 16 months starting in January of '12. The entry fee for a 45-footer will be about \$17,500 U.S., plus about \$2,200 U.S. per crew. These fees include the Canal transit, which would normally be about \$600, and tours and activities at each stopover. The 31-boat ARC World '10-'11 fleet was most recently in Tonga. Four entries are from the U.S.: Robert and Trish Budd's Shannon 43 **Bristol Rose**; Joseph Metz's Amel



*Why do an ARC and sail across the Atlantic? Because the sailing is superb, and once you get the Caribbean, the sunsets are, too.*

53 **Brown-Eyed Girl**; William Thomas' Sundeer 60 **Crazy Horse**; and Jim Geddes' Sundeer 60 **Ocean Jasper**.

Everybody at the Police Dock in San Diego in June had just done the Bash up from Mexico — everybody but the Boren family of Port San Luis-based Pearson 365 **Third Day**. Vets of the '08 and '09 Ha-Ha's, they were about to head back down to Mexico — but with a new boat.

## SCHOONMAKER POINT MARINA

• IN SAUSALITO •



Call the Marina Office  
for more information

**415•331•5550**

**FAX 415•331•8523**

or check our web site at  
[www.schoonmakermarina.com](http://www.schoonmakermarina.com)

85 LIBERTY SHIP WAY, #205  
SAUSALITO, CA 94965



### 160 Berth Marina in one of the most beautiful spots on the Bay

- Visitor berths • Guest moorage able to handle yachts up to 200 ft.
- Dry storage • Waterfront Offices • Three-ton Hoist • Windsurfing
- Deli • Beach • Rowing • Kayaking • Yacht clubs always welcome

# CHANGES

"The Pearson 365 has been a terrific cruising boat for us," Richard explains. "But for our last year in Mexico, we wanted a bigger boat, so we bought a Hudson 52 ketch." His wife Laura adds, "The boys weren't very happy because they loved the old boat, but they instantly changed their minds when they saw that they were each going to get their own cabin." Richard says the he's learned so much after two years of cruising. "Before we did our first Ha-Ha, we thought we had to replace everything old with new stuff, even if it was still working, and that we had to replace it before we crossed the border. Now we know that old stuff that works is as good as most new stuff, plus you don't have to install it. And as long as the boat is in basic working condition, you can put off projects until you get down to Mexico, where you're have more time to do them. We're sailing down to Mazatlan to offload the stuff from our old boat onto our new boat, then we're headed up to



**Laura and Richard Boren at the helm of their new-to-them 51-ft ketch. As of the middle of June, they were sailing south to Mexico.**

the Sea for another summer. After one more year in Mexico, we'll probably sail back and become liveboards in Morro Bay." It's not something the kids are going to like. "They love cruising and aren't going to want to come back," sighs Laura. The one thing she won't miss about cruising is home-schooling the kids.

"Everyone who does it will tell you that it's not easy."

"How long does it take to do a **Baja Bash** from Cabo to San Diego after the Ha-Ha?" is one of the most frequent questions the Grand Poobah and Assistant Poobah get asked when giving presentations to prospective Ha-Ha participants. In one of this month's *Changes*, Myron and Marina Eisenzimmer report that the first four Bashes they did with their Swan 44 MKII **Mykonos**

took between 7 to 10 days, but the most recent one took 17 days. We think 7 to 10 days is a good guideline for a Bash — with the obvious outside possibility that it could take as long as 17 days. May the weather gods be with you, and even more important, may you have the luxury of not having a deadline.

Remember, **we'd love to hear from you**. Even just a few paragraphs with the basic facts of your trip would be great, and a couple of high-resolution photos of you makes it even better.



## OYSTER POINT Marina/Park



*A full service marina located in South San Francisco with berthing and guest dockage available*

For information and pricing call  
**(650) 952-0808**  
[www.smharbor.com/oysterpoint](http://www.smharbor.com/oysterpoint)

## Custom Canvas & Interiors



The Gianola Family has been designing and fabricating custom canvas and interiors since 1969. Gianola Canvas Products offers you the best in quality, more choices, and personal service.



265-B Gate 5 Road  
Sausalito, CA 94965  
(415) 332-3339  
[www.gianolacanvas.com](http://www.gianolacanvas.com)



**deWitt**

To commission  
**Jim DeWitt to paint a  
 painting of your boat  
 or anything you  
 treasure, call Pam...**

*DeWitt painting to be used  
 as a perpetual trophy.  
 Thank you Bill Kreysler!*

**DeWitt Art Gallery & Framing**  
 121 Park Place, Point Richmond, CA 94801  
**(510) 236-1401 | (800) 758-4291**

**www.jimdewitt.com • www.dewittgalleryandframing.com**

Tuesday-Saturday 11:00-7:00 • Sunday 9:30-5:30

## COMPUTER ABOARD?

CAPN & Digital Charts  
 AIS • WiFi • Cellular Amps  
 SatPhones: Iridium & Globalstar  
 HF SSB Radio & Pactor Modems  
*Wireless E-mail*



**SEATECH SYSTEMS™**  
 800.444.2581 • 281.334.1174  
 info@sea-tech.com • www.sea-tech.com

Call for Info on SeaTech Packages and CAPN Demo Disk

97% First Time Pass Rate • 100% Satisfied Students

**MARITIME INSTITUTE**  
 INCORPORATED



**Captain's  
 License**

Our NEXT  
**SAN RAFAEL**  
 Class begins  
**July 5th**

Official  
 Sponsor  
 2010  
**BAJA  
 HA-HA**

Call Toll Free  
**888-262-8020**  
 www.maritimeinstitute.com

**NEW! ONLINE COURSES**

**FAST SHIPPING!**

### NEW AND USED SAILS!

Specializing in production boats and featuring the largest selection of stock sails available anywhere! Save with warehouse volume discounts on Stock Sails, Custom Sails, Sail Covers, Furlers and Accessories. All top Quality.

**All Fully Guaranteed!**

- Full Batten Mains
- Furling Genoa's
- Storm Jibs
- Trysails
- Furling Units
- Custom Canvas
- Used Sails

**THE SAIL WAREHOUSE**

**VISA THE SAIL WAREHOUSE MasterCard**  
 Ph. (831) 646-5346 www.thesailwarehouse.com

**HAWAII**

## LONG TERM DRY STORAGE

*Clear Customs at our dock*

**GENTRY'S  
 KONA MARINA**

**HONOKOHAU HARBOR** 156°1'30" W  
 19°40'20" N

TOLL FREE **888-458-7896**  
**www.gentryskonamarina.com**

The friendliest boatyard in Hawaii

Please read before submitting ad

# Classy CLASSIFIEDS

## Here's What To Do:

**Write your ad.** Indicate category. Remember price and contact info. We make final placement determination.

**Count the words.** Anything with a space before and after counts as one word. We will spell-check, abbreviate, edit, as necessary.

**Mail your ad** with check or money order, deliver to our office; **OR, for the best - and most exposure - of your classified ad...**

**Submit your ad safely online** with Visa, MasterCard or AmEx at: **www.latitude38.com**

Ad will be posted online within two business days, appear in the next issue of the magazine, and remain online until the following issue is released.

### PERSONAL ADS

1-40 Words.....\$40  
41-80 Words.....\$65  
81-120 Words....\$90  
Photo.....\$30

• Personal Advertising Only •  
No business or promo ads except Non-Profit, Job Op, Business Op

**'Trying to Locate' Ads** are for those searching for lost boats/people - not shopping - and cost **\$10 for 20 words max**

**FREE Online Ads** are for a private party selling a boat for less than \$1,000 - or gear totalling under \$1,000. (One per person; must list prices in ad.)

All ads will be set to fit *Latitude 38* standard • Re-Run Ads: Same price, same deadline

### BUSINESS ADS

**\$70 for 40 Words Max**

• All promotional advertising •  
1 boat per broker per issue  
Logo OK, but no photos/reversals  
No extra bold type • Max: 12 pt font  
Artwork subject to editor approval.  
Biz ads will not appear on website.

## DEADLINE

is **ALWAYS** the **18th at 5 pm**

for ad to appear in the next issue.

*Due to our short lead time, deadlines are very strict and include weekends & holidays.*

**Sorry, but...**

- No ads accepted by phone
- No ads without payments
- No billing arrangements
- No verification of receipt
- We reserve the right to refuse poor quality photos or illegible ads.

*Latitude 38* 15 Locust Ave, Mill Valley, CA 94941 Questions? (415) 383-8200, ext 104 • class@latitude38.com

**WHAT'S IN A DEADLINE?** Our Classified Deadline has always been the 18th of the month, and it's still pretty much a brick wall if you want to get your ad into the magazine. But it's not so important anymore when it comes to getting exposure for your ad. With our new system, your ad gets posted to our website within a day or so of submission. Then it appears in the next issue of the magazine. So you're much better off if you submit or renew your ad early in the month. That way your ad begins to work for you immediately. There's no reason to wait for the last minute.

**12-FT BEAMY FIBERGLASS CABIN** sloop, \$450. with keel, oak rudder, electric outboard. Cargo or passengers can stay dry, secure and out of the sun. Sleeps 2. Cute and stable, self bailing. Mast comes down easily. Also available: small dodger, trailer (to 17') and 2hp Evinrude. (415) 999-5626 or rogercperry@gmail.com.

### 24 FEET & UNDER



**23-FT DEHLER SPRINTA SPORT, 1981.** South Beach YC, SF. \$3,500. Dehler design by Van de Stadt. *Momentum* is an exciting racer/cruiser with rebuilt outboard, new Pineapple mainsail, Harken headfoil and berth covers. Fractional rig. <http://sites.google.com/site/sprintasport23>. (415) 683-3632 or tanyak@gmail.com.

**J/24, NIXON WAS COOL.** \$REDUCED \$9,500. Multi-season SF Bay fleet champion. Fast, ready-to-go one-design racer, with dual-axle trailer. New North San Diego sails, outboard, Tacktick, new standing rigging and boom. Details at website. [www.gybethejib.com/nixon](http://www.gybethejib.com/nixon). (415) 595-2566 or chet\_chauhan@yahoo.com.



**23-FT COLUMBIA T23, 1973.** \$2,500. Trailerable 23 foot Columbia. Minimally used. Well maintained boat, inside and out. Rebuilt trailer, newer cushions. Mast and rigging are solid. Main and jib are fair. Low hours 6hp Johnson outboard. (925) 408-6568 or hansloffeld@gmail.com.



**22-FT MULL POCKET ROCKET, 1989.** Hood River, OR. \$13,500. New mast, rigging, sails, 2004. All new paint 2008. Self-tailers, self-tacking hardware, instruments, trailer. Lots of extras. More info and pictures on website. [www.gorgesat.com/rocketboat](http://www.gorgesat.com/rocketboat) (541) 386-2037, (541) 490-3119 or gorgerocket@earthlink.net.

**24-FT MELGES, ALAMEDA BOATYARD.** \$20,000. Hull #14. Race ready. Full boat covers. Contact Frank. (512) 750-5735 or cabosportsfrank@yahoo.com.

**20-FT PACIFIC SEACRAFT FLICKA.** 1992. San Carlos, MX. \$45,000/obo. *Dulcinea*. This beautiful little girl is in excellent condition and ready to take you anywhere. Winner of the Agave Division, Soul Sailor Award, Most Dangerous Catch on the Smallest Boat Award in the "Lucky 13" Baja Ha-Ha. Fully loaded. Presently cruising in the Sea of Cortez. Check her out: <http://picasaweb.google.com/sirena.jh/Dulcinea02?authkey=Gv1sRgCLWk1t-B3fXvCA#>. (001) 521-322-888-2923 or randy.ramirez@sbcglobal.net.



**J/24, 1979.** Berkeley Marina. \$5,000. Two full sets of sails. Complete running rigging and deck hardware. Bottom completely redone in 2006. Distinctive yellow hull. Great condition, well-maintained boat, sailed often. Desirable Berkeley slip, near BYC, transferable. (415) 912-9102 or darrenwc@gmail.com.

**24-FT YANKEE DOLPHIN, 1971.** Benicia. \$7,900. Sparkman & Stephens design full keel center boarder. "Beautiful pocket cruiser". 6hp Suzuki 4 stroke in well, sink, ice box, stove, Porta-Potti, compass, depth, w/Trail-Rite tandem axle trailer w/launching tongue. (707) 747-9240 or rcenglar@comcast.net.

## DINGHIES, LIFERAFTS AND ROWBOATS



**14-FT MEGABYTE, 2006.** El Dorado Hills, CA. \$4,900. Immaculate. Garaged. Regatta-winning boat. Mk II and standard sails and rigs in excellent condition. Custom main cam cleat. Like-new trailer. #343. Boat of the Year by Bruce Farr. (916) 933-8860, (916) 933-3414 or john@poinmiroo.com.

Yacht Repair  
Design / Consulting  
Custom Interiors  
Exterior Joinery



### STEVE'S MARINE WOODWORK

60 C Libertyship Way, Sausalito  
jonnessail@aol.com • (415) 332-2500

### N.E. MARINE TITLE

Coast Guard documentation • Title/lien searches • Transfers • Mortgage filing • Escrow services  
Local closing facility for brokers or private transactions  
30 years experience of doing it right the first time

1150 Ballena Blvd, Alameda, CA • (510) 521-4925



### NOR-CAL COMPASS

Adjustment • Sales

Authorized Compass Repair

Hal McCormack • norcal.compass@verizon.net • Phone/Fax (415) 892-7177

## BOAT • LETTERING

alphaboatsue@aol.com • (510) 599-1197 • www.alphaboatgraphics.com

Creative and durable lettering and artwork for your boat





**22-FT MACGREGOR, 1982.** San Jose. \$2000/obo. On a 1998 Reinell trailer. Great condition. Complete with sails, portable toilet, life jackets, anchor with rode and line, fenders. (408) 247-0104.

**24-FT MOORE, HULL #93, 1981.** Alameda Marina, CA. \$16,000. Boat name: Sea Pearl. Description: Epoxy bottom and topsides. New rigging. Refastened deck fittings. New varnish below. (415) 771-8427 or scampoli@sbcglobal.net.



**24-FT MELGES, 1999.** San Francisco. \$28,500. Hull # 417. Lightly used and one of the fast 400 series boats. New: (1) boom, (2) top and bottom keel Delrins, (3) companionway launcher (complete), (4) reinforced stanchion elbows, (4) tiller, (5) Hutchinson lifelines, (6) spare forestay, (7) spare SS jib halyard, (8) bow sprit, (9) Mercury 4hp outboard. Comes complete with trailer, cover and a decent set of sails. Now is the time to grab this hot boat and start building up to some world class regattas on the West Coast, including the North Americans (San Francisco) in 2012 and Worlds (San Francisco) in 2013. Reduced from \$35,000 to \$28,500. www.jamjam.com. (415) 606-5766 or nealruxton@gmail.com.

## 25 TO 28 FEET



**28-FT ALERION EXPRESS, 2002.** \$67,500/obo. Yanmar diesel, new autopilot, main & jib sails, GPS, wind, depth, etc. Dark green hull. Bottom paint & new MaxProp Nov. 2009. Excellent condition. Prime downtown Sausalito berth. Health reasons force sale. (415) 850-8110 or nizzaneoz@aol.com.



**28-FT ISLANDER, 1984.** Emeryville. \$19,900. *Ridiculous.* Cruiser/racer in great condition. North main, Mylar/Kevlar genoa, jib halyard and sheets, lifelines and batteries, all 2008. Standing rigging replaced 2005. 2009 bottom, diver maintained. Wheel, Yanmar diesel. Roller furler, spinnaker pole, second jib, stereo, VHF, depth, knotmeter, new TackTick wind instrument, lazy jacks, new companionway and wheel covers. (510) 531-4204 or RBF355@aol.com.

**27-FT CATALINA, 1985.** Oakland. \$14,500. Key ready, great condition inside and out. Universal diesel with new drive shaft, bearings and PSS seal. Wheel steering w/auto steer, nice dodger, roller reefing genoa, lifelines. Just hauled and bottom painted. Recently surveyed at \$17,500. (510) 357-8549 or frawil@sbcglobal.net.

**26-FT MARIEHOLM IF BOAT, 1968.** Alameda Marina. \$8,000. For sale, Marieholm IF Boat hull #89, new barrier coat '07, new Mercury 6hp 4-stroke, unused inflatable by Avon, Meisner winches, oversized rigging, beautiful teak interior. Well-loved, reluctant sale, \$8,000 firm. (415) 244-3928 or monkeyjack580@hotmail.com.



**26-FT MACGREGOR, 2005.** South San Francisco. \$29,500. Fully loaded and customized MacGregor 26 M. You simply can't get a boat like this new from a dealer. More than \$55K invested. Very good condition. Custom ballasted keel, high-performance Quantum sails, autopilot, GPS, wind data, full enclosure canvas package, virtually all the hardware has been upgraded & much more. Evinrude Etec 50hp outboard. Great sailboat. Motors at 15 kts+ EZ to trailer. Trailer included. http://delevi.com/rusalka.htm. (415) 235-4652 or ldelevi@pacunion.com.

**27-FT CHEOY LEE OFFSHORE CADET.** 1968. Miranda, CA. \$7,000. Classic Cheoy Lee 27-ft Cadet with trailer. Traditional line, solid fiberglass hull, teak trim, teak interior, Volvo diesel engine. Great project boat at an unbeatable price, needs good home. (707) 498-4332 or soundstoo@yahoo.com.

**26-FT ZAP, 1979.** \$9,500. Bruce King designed ultralight sportboat, external lead, flush deck, open transom, Ballenger tapered spar, 7/8ths rig. Complete \$12,000 restoration: Navtec, North, Autohelm, Metal Magic, Lewmar, Harken, Blue Seas, Horizon, Mariner 6hp. Optimized shorthanded, spirited sailing. (510) 277-2291.



**25-FT CHEOY LEE FRISCO FLYER.** 1958. \$17,995. Beautiful, great sailing, all teak, copper riveted, outstanding condition. No surprises: five years recent major work from mast to hull, plus all new: sails, rigging, electrical, boom, cast bronze hardware, engine overhaul. http://friscoflyer.net. (360) 325-5022 or inquiry@friscoflyer.net.

**25-FT MARIEHOLM INTERNATIONAL.** Folkboat, 1973. Channel Islands Harbor, Oxnard, CA. \$5,000. Wonderful classic Swedish pocket cruiser. In great shape, kept simple, rigged for singlehanding. Not many of these in Southern California. Email for pix and info. baron\_cosimo@yahoo.com.



**27-FT NOR'SEA, 1980.** Monterey Bay. \$20,000. Tough, basic little cruiser with unique junk rig and custom mods for blue water work. Monitor vane. Fiji vet, offshore gear including liferaft, para anchor, etc. www.kabai.com/seablossom. (408) 218-9604 or kabai@yahoo.com.



**25-FT SANTANA 525, 1980.** Lake Don Pedro Fleming Meadow. \$3,000/obo. New North Sail mainsail, gennaker & rigging, 24 volt electric motor with solar panels for recharging. Excellent condition. (209) 575-2653 ext: 303, (209) 471-9968 or mb@modestocpas.com.



**25-FT HUNTER 25.5, 1984.** Coyote Point, San Mateo. \$10,000. Racer/cruiser fixed-keel 9' 1" beam, sleeps-6. Excellent condition. Rigger for San Francisco Bay. 135% furling jib, main 2008, 2 anchors, Porta-Potti, dinette, 2-burner alcohol-stove, Tandem trailer, 4-cycle Mercury 9.9OB 2006. Rigging, bottom-2008. http://99.62.231.42/Antidote/MoreInfo.htm. (408) 866-2429 or baysailor2000@att.net.

**25-FT CATALINA, 1980.** Berkeley Marina, Dock M-113. \$5,500. Well maintained, full keel, pop-top w/cover, classic dinette, new upholstered cushions, lots of wood, sleeps six. Mercury 6hp low miles. Great location. Email for pix and info. (510) 681-5677 or wgraybill@yahoo.com.



**25-FT OLSON, 1988.** Alameda. \$9,500. New 6hp Mercury OBM, whisker pole, VHF radio, 2 anchors, cockpit cushions, main, working jib, genoa, new mainsail cover, alcohol stove, 2 coolers, Porta-Potti. Lines led aft for easy singlehanding. Great shape. (510) 995-8852 or tbstrand@comcast.net.

**27-FT BRISTOL, 1977.** Berkeley. \$7,900. Beautiful classic yacht. Very solid boat, hasn't been sailed much in the last 3 years, so needs some clean and polish. Comes with lots of extra gear and decent sails (1 main, 3 jibs). (510) 334-1135 or rob@robconant.com.

**25-FT CATALINA, 1983.** Stockton. Swing keel, excellent condition, Harken roller furling, Lewmar self-tailing. Like new sails. Autopilot. All lines run aft. Has head with holding tank. 2-burner stove. 9.9 Evinrude with electric start. VHF radio, new AM/FM CD stereo. 7" color HDTV. Knotmeter, depth finder and compass. Hand-held VHF and AM/FM, Garmin GPS, new 4-man raft w/oars + pump. BBQ. NADA value \$7,620 to \$8,685 less motor. Local market suggests around \$6,000/obo. (209) 365-0668 or rpatrick@padlocke.com.



**WOODRUM MARINE**  
Specializing in custom interior  
cabinetry, tables, cabinets, countertops,  
cabinsoles. For power or sail.

**CARPENTRY**  
Mobile cabinet shop  
Contact Lon Woodrum at:  
**415-420-5970**  
www.woodrummarine.com

**Mike Maurice @ YachtsDelivered.com**  
Power - 45 Years Experience - Sail  
Expert- No. Pacific/4Seasons & Bar Crossings  
China-Alaska +1-503-310-7590 - Caribbean

**Jack D. Scullion**  
Yacht Services  
jdsyachts@att.net  
(510) 919-0001

Rigging  
Electronics  
Troubleshooting  
Electrical Installations  
We Gladly Install Gear You Provide **NEILPRYDE SAILS**



**MARINE SURVEYS by Captain Alan Hugenot**  
Naval Architect • Yacht Delivery Skipper  
Accredited Marine Surveyor (SAMS)  
Bay or Delta • No Travel Charges • MC / VISA / AmEx  
alan@captainhugenot.com • (415) 531-6172

## ABC DIVING

Hull Cleaning • Zinc Replacement • Light Salvage



**Brian Hernandez**  
P.O. Box 1402  
Sausalito, CA 94966  
**(415) 283-7860**  
bmh07@hotmail.com

## MARINE SERVICE CORPS

- your -

## MOBILE PUMPOUT SOLUTION

(510) 629-4185 ~ (415) 370-6812

**\$25 PUMPOUT\*** (includes freshwater rinse)

Ask us about our **20% DISCOUNT** for yacht club members & liveaboards.

\*up to 40 gallons

weatherguy.com

## Worldwide Marine Forecasts Cruising, Racing & Commercial Packages Starting at \$65.00 USD

(866) 882-WXGY (9949) toll free  
(808) 291-WXGY (Mobile)  
(808) 254-2525 (Office)  
(808) 443-0889 (Fax)



970 N Kalaheo Ave  
Suite C-104  
Kailua, Hawaii 96734  
info@weatherguy.com

www.weatherguy.com



**1,000 Used Sails**  
Listed at  
**minneysyachtsurplus.com**

**We Buy Good Used Sails  
and Marine Equipment**

**MINNEY'S YACHT SURPLUS**  
1500 Newport Bl., Costa Mesa, CA  
949-548-4192 • minneys@aol.com

"We keep boating affordable!"

**26-FT PEARSON ARIEL, 1964.** Sausalito \$3,200/obo. Full suit o' sails, 2 speed-self tailing Lewmars, all lines led aft, strong inboard. Stout Bay/ocean boat that sails great, and needs a little dollying up. Perfect beginner boat or cruiser with a few upgrades. Possible Sausalito slip transfer. (415) 225-4319.

### 29 TO 31 FEET



**31-FT HUNTER, 2007.** Treasure Island. \$84,900. Like new. In-mast furling, new bottom paint and yearly engine maintenance, Yanmar 21hp, enclosed head/shower, private aft sleeping berth, Raymarine C80, autopilot, ST60 windmachine, ST40 depth, ST40 knot, top loading reffrig, cockpit stereo speakers and VHF extension, bimini. (650) 995-4624 or tjweisbr@aol.com.

**CAL 2-29, 1972.** Alameda. \$7,500. Great sailing boat with a nice spacious interior. Lines led aft, full batten main with 3 reefs, furling jib, 15hp 4 stroke, head with holding tank, wheel steering. (510) 593-8697 or ssnick@gmail.com.

**ERICSON 30+, 1980.** Sierra Point in Brisbane. \$223,500. Job furler, cruising spinnaker, autopilot, diesel, recently hauled and regularly maintained. One owner since 1980. Contact Ralf Nielsen. (650) 533-0840, (650) 348-7389 or drbradcase@sbcglobal.net.

**30-FT ISLANDER, 1971.** Moss Landing Harbor District. \$9,780. Mk II. 4-cyl gas inboard (Palmer P60). Fiberglass hull w/ teak trim. 3-burner alcohol stove/oven, BBQ. Depth/fishfinder, CB and VHF radio. Recent work: Sept '09 hauled out, tuned up, oil change, new head, replaced through hulls and zincs. Sails include spinnaker, 2 storm jibs, 100% & 130% genoa. Mahogany interior. 5 lifejackets, lots of extras. Sleeps 4 comfortably. Good solid boat. Ready to sail. Take over slip. (831) 915-6783 or (831) 659-1921 or drbradcase@sbcglobal.net.

**J/29, 1985.** Seattle. \$19,950. Great race record, masthead rig, hydraulic backstay, B&G, stereo, rod rigging. Restored in 2002. (253) 288-0117 or stevemil@graham.com.



**30-FT SANTANA 3030PC, 1982.** Ventura. \$27,000. Race or cruise. 2cyl Yanmar 267hrs. New headliner/cabin sole/electrical panels. New rod rigging. Harken traveler/genoa leads. Harken roller furler, dodger, H/C pressure shower, CNG stove/oven. Full sail inventory. Too much to list. (805) 581-9220 or dnclaws@aol.com.

**30-FT NEWPORT, 1974.** Sausalito. \$3,700/obo. By Capital Yacht. Good Atomic 4 and transmission. Very nice varnish and exterior. Roomy interior. Possible liveboard (with permission). Needs to be loved and sailed. Sacrifice to first semi-reasonable offer. Some trades may be considered. (415) 999-5626 or rogercperry@gmail.com.

**30-FT CATALINA, 1978.** Oxnard, CA. \$18,900. Tall mast. Universal diesel 30hp. Only 100 hrs! Very clean & totally upgraded throughout, incl mast, boom & rigging. Exceptional condition! Impressive recent survey. Currently insured. Call or email for pics or info. (805) 200-6089 or traim69@hotmail.com.

**30-FT RAWSON CRUISER, 1964.** Berkeley, CA. \$6,900. #83. Heavy fiberglass construction, William Garden design, 6 feet headroom, enclosed head. Dodger, roller furler genoa, two mains, spinnaker and more. No engine. (415) 637-6984 or hugo42\_98@yahoo.com.



**30-FT CAPE DORY, 1982.** Morro Bay. \$30,000. Wonderful sea-kindly cutter. One of Carl Alberg's best designs. Volvo MD7A, VHF, radar, chartplotter, autopilot, depth meter, roller furling headsail, dodger, cockpit shade and more. Bought bigger boat - must sell. bobjenkizziar@sbcglobal.net.

**30-FT HUNTER, 1992.** Clipper Marina, Sausalito. \$26,950. Very clean, well maintained roomy inside, terrific sailing Hunter. New batteries and charger, new bottom paint, replaced holding tank and plumbing lines, fuel tank scrubbed and all new fuel lines, 17hp Yanmar diesel, runs like a top. (707) 477-0672.



**Fred Andersen Boat & Woodworks**

**Repair,  
Restoration &  
New Construction**  
(510) 522-2705



### STARBOARD YACHT DELIVERIES

Over 50,000 sea miles • Pacific, Caribbean, Atlantic  
USCG Master 100 GT STCW • Power & Sail

**Rick Whiting • (415) 740-2924 • captain\_rick@sbcglobal.net**

**31-FT PACIFIC SEACRAFT MARIAH.** Mk II, 1979. SF BAY. \$49,000. Bluewater cruiser, cutter rigged. Built of utmost quality and cost. Beautiful interior, full galley, fresh Yanmar, solar, watermaker, refrigeration, complete spares inventory, near ready cruise condition. FRP decks, exceptional vessel. See listing at: [www.sailboatlistings.com/view/17868](http://www.sailboatlistings.com/view/17868). By appt. Robert. (707) 590-6047 or [mcsi@gmx.com](mailto:mcsi@gmx.com).

**NEWPORT 30 II, 1979.** San Francisco. \$17,000. Wheel steering, 16hp diesel, roller furling, main, 2 jibs, spinnaker all in VG condition. Auto pilot, wind instruments, CNG SS stove, smart battery charger, inverter. Too much equipment to list. Email for list. SF Marina berth transferable. (415) 564-5209 or [bswanson1@sbcglobal.net](mailto:bswanson1@sbcglobal.net).

**30-FT KNARR, 1975.** SF Marina. \$28,000. #128 fiberglass Knarr in excellent condition. New running rigging and cover. Fresh brightwork. Fast, stiff and stable. Ready to race in the best one design class on the bay. Coveted SF Marina slip possible for additional consideration. Will also consider 50% partnership. [www.sfbayknarr.com](http://www.sfbayknarr.com). (415) 342-4645 or [steve@gmpc.com](mailto:steve@gmpc.com).



**30-FT CATALINA, 1995.** Alameda. \$55,000. Walk-through transom, wing keel, three bladed prop, Universal diesel, low hours, Autohelm, wind, depth, self-tending roller furling 100% jib, plus 130% genoa, two anchors, extra two-blade prop, new line, custom doors, new canvas including bimini, rail seats, TV, stereo, microwave, carpet, cushions, unused barbecue, more. Pristine. Prettiest 30 on the Bay. Pics available. (510) 220-1952 or [pmnewton@mac.com](mailto:pmnewton@mac.com).

**30-FT ISLANDER, 1969.** \$10,000/obo. Hand laid fiberglass. Flush deck. Unique design. New mainsail, rigging, halyards, spreaders, turnbuckles, bow rail, lifelines, rudder shoe, bottom and topside paint, electronics, upholstery, many upgrades. Beautiful vessel, must sell. (510) 301-0776.

**30-FT CORONADO, 1969.** Rio Vista. \$17,500. Diesel, wheel, dodger, radar, chartplotter, all new, Harken roller furling, boom, sails, all standing and running rigging, too much to list. (916) 837-2386 or [sinner696@gmail.com](mailto:sinner696@gmail.com).



**30-FT FISHER/NORTHEASTER, 1976.** San Diego, CA. \$79,500. The aft cabin version of the famous British motorsailer Fisher yachts. New Yanmar, new North sails. She is absolutely Bristol inside and out. For photos and complete information see website. [www.will-shelton.com](http://www.will-shelton.com). (619) 616-9209 or [csdales@yahoo.com](mailto:csdales@yahoo.com).



**30-FT CAPO - SCHUMACHER DESIGN / Westerly Built, 1984.** San Diego. \$34,000. Rare find. BIG 30 footer. Well maintained. Full sail inventory, new main, full headroom, full electronics - 5 displays, Yanmar diesel. Great race record. Email for more photos/info. [david\\_vieregg@intuiti.com](mailto:david_vieregg@intuiti.com) or (650) 450-3496.

**30-FT SEIDELMANN 299, 1979.** Pelican Harbor, Sausalito. \$9,500/obo. Great cruising sloop. Speed, full keel, comfortable accommodations. Yanmar diesel, radio, depthfinder, knotmeter, extra jib, well maintained. Motivated seller. Sausalito slip available to qualified buyer. (707) 972-1524, (707) 462-1851 or [mike@pacific.net](mailto:mike@pacific.net).

**30-FT LANCER, C&C DESIGN, 1980.** Marina Bay, Pt. Richmond. \$25,000. Fractional sloop, wheel steering, with inboard Yanmar QM15. Redecorated cabin, new electronics, VHF, GPS & chartplotter. New sails, safety lines, shrouds, dodger, wheel pilot, roller furling and more. (916) 487-5351 or [barronsdesign@surewest.net](mailto:barronsdesign@surewest.net).



**29-FT COLUMBIA SLOOP, 1967.** Sausalito. \$12,500. May consider partial trade. She loves the wind! Sparkman & Stephens design, Yanmar diesel with low hours. Propane stove, marine radio, safety equipment. Wired for shore power. Excellent condition! Almost everything has been upgraded. Electronics. (707) 312-0860 or [larrystofer@yahoo.com](mailto:larrystofer@yahoo.com).

**30-FT ISLANDER MK II, 1975.** Santa Cruz. \$17,500. This is a great sailing boat in excellent condition! 15hp diesel. Wheel steering. (Harken) Roller-furling jib. Boat cover. Engine rebuilt (less than 50 hours!), complete re-fit during the last year. New gear: exhaust system, standing rigging (Svenson's), cockpit cushions, bilge pumps (manual and electric), thru-hull fittings, stuffing box, rudder post sleeve, starter battery, bottom paint & more. Sails refurbished by Santa Cruz Sails last month. Lots of TLC. (831) 465-9550 or [correa-mickel@sbcglobal.net](mailto:correa-mickel@sbcglobal.net).



**30-FT OLSON, 1982.** Richmond, CA. *Runs With Scissors.* 1982 Olson 30, Hull number 209. Fully restored/upgraded in 2004. Extensive sail control systems. Multiple sails, including Sobstad Pentax main and #1 (racing sails). For additional photos and full specs, please visit website. Please contact Brett McLarney with any questions or to arrange a time to see the boat. <http://s1024.photobucket.com/albums/y309/1982Olson30/?start=all>. [brettmclarney@yahoo.com](mailto:brettmclarney@yahoo.com).

**30-FT OLSON, RICHMOND, CA.** \$14,500. Hull #1 *Mas Rapido*. Big Daddy, Great Pumpkin and one design winner. New Santa Cruz spinnaker and #1. Class legal "Beam of Destiny" hull stiffeners and jock strap. Great trailer. Race ready. (831) 277-1490 or [RSmith0024@aol.com](mailto:RSmith0024@aol.com).

**30-FT ETCHELLS, 1995.** Brickyard Cove, Richmond, CA. \$22,000/obo. Etechells, USA 1016 FOR SALE! Will also consider charter through the 2011 Worlds. Act fast. Sale: \$22,000/obo. Charter: \$15,000. Call or email for details. (415) 488-7766 or [nb Ballard76@comcast.net](mailto:nb Ballard76@comcast.net).

**29-FT CAL 2-29, 1978.** Berkeley \$12,500/obo. Well-maintained, excellent Yanmar diesel, Racor filter, new Optima batteries, Xantrex, charger, pedestal steering, Harken rollerfurl, windlass, depth, speed, VHF, nice teak interior, new cushions, pressurized water, LPG, Pioneer stereo, newer head, more. [peabodypeabody@gmail.com](mailto:peabodypeabody@gmail.com) or (510) 225-8074.

## 32 TO 35 FEET

**34-FT SAN JUAN, 1984.** \$39,000. Price reduced. Fast comfortable, blue water cruiser, excellent condition. 6' headroom, galley, sleeps six, rod rigging. Roller furling headsail, 150% genoa, main, working jib. 3GMD Yanmar, Achilles dinghy, large bimini. Original owner. (510) 420-8956 or [nino@access-print.com](mailto:nino@access-print.com).



**32-FT CHRIS CRAFT CHEROKEE.** 1968. Redwood City Marina. \$12,000. Sturdy, elegant, in great condition, open-ocean cruising: VHF, GPS, diesel engine, radar, head, stove, bulb keel, lots of spares. Perfect for sailing inside and outside of the Bay. See more at <http://andreashehrensberger.blogspot.com>. (530) 902-7987 or [aehrens@gmail.com](mailto:aehrens@gmail.com).

**32-FT ERICSON, 1974.** Redwood City. \$16,900. Beta Marine 220hrs, Alpha 3000 autopilot, 100%, 125% UK tape drive new, roller furling, self tailing winches, all lines led aft, dodger, SSB, depth & knotmeter 3 reef main, surveyed July 2009. (650) 575-2466 or [PatTuna22@aol.com](mailto:PatTuna22@aol.com).



**34-FT C&C, 1979.** South Beach Harbor. \$29,500. Great sailboat in great shape. 90, 110, 150 jibs, flasher and main, YQ20M Yanmar diesel, 10-ft West Marine inflatable dinghy with 8hp Tohatsu. Complete survey on June 4, all items professionally repaired. She is an awesome lady and will make a great addition to your family. (207) 650-6855 or [herbert.gillman@gmail.com](mailto:herbert.gillman@gmail.com).

**32-FT FUJI KETCH PROJECT BOAT.** 1976. Monterey. \$7,800/best offer. THE GOOD: Tons of storage, crafted cabinetry, fresh sails, roller furling, recent refit for Mexico trip: Nexus instrumentation, some new sea cocks, bottom job and much more. THE BAD: MD2b needs head and cylinder 2 - blown head gasket. We've located both an engine for spare parts, and a Volvo MD11c which installs with no modifications. THE UGLY: storm seriously damaged bowsprit, fiberglass damage to deck meets stem. [cyndimarcus@hotmail.com](mailto:cyndimarcus@hotmail.com).

**32-FT WESTSAIL, 1976.** Alameda. \$39,000. Factory finished, Perkins 4-108. New roller furler, autopilot, stove, h/c pressure water. Interior and canvas in excellent condition. Manual windlass, VHF. Great shape and nothing funky! (510) 864-3930, (919) 522-1685 or [dfharris02@yahoo.com](mailto:dfharris02@yahoo.com).



magnetic signal flags!

pirate poetry!

check it out!

[WWW.OCEANPOETRYDESIGNS.COM](http://WWW.OCEANPOETRYDESIGNS.COM)



YOGA FOR SAILORS ON THE SAN RAFAEL WATERFRONT

Small group classes Wednesdays 9:00-9:45 a.m.; Tuesdays & Thursdays 6:30-8:00 p.m. First class free when you mention this ad! See [www.bowyoga.com](http://www.bowyoga.com). [yogaforu2009@gmail.com](mailto:yogaforu2009@gmail.com), (415) 785-4530, (510) 333-8846

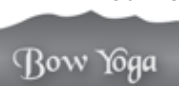

**WHILE YOU'RE AWAY YOUR ANIMALS CAN PLAY**

And you can know they are warm, safe, and being looked after.

KITTY COTTAGE  
Cageless cat boarding

Insured through PSA, LLC.

**C-and-S-California.com**

DOGGIEVENTURE  
A doggie daycare on the go!

**THIS COULD BE YOU...**

Let the Classy Classified business ads work for you.

Submit online at:

[www.latitude38.com](http://www.latitude38.com)

# MARINA DE LA PAZ FULL SERVICE MARINA

S.A. DE C.V.

Friendly, helpful, fully bilingual staff

All new hardwood docks • Wireless Internet  
Dinghy landing with potable water  
New protective piling & sheetpile breakwaters • And more!

TEL: 01152 612 122 1646  
email: marinalapaz@prodigy.net.mx  
[www.marinelapaz.com](http://www.marinelapaz.com)

Apdo. Postal 290, La Paz, 23000, Baja California Sur, Mexico

## VOLVO PENTA

ENGINES • PARTS • SERVICE

We Ship Anywhere

1-800-326-5135

(415) 453-1001  
FAX: (415) 453-8460  
[www.helmutsmarine.com](http://www.helmutsmarine.com)  
619 Canal Street  
San Rafael, CA 94901

Call us for your nearest Volvo Penta dealer 1-800-326-5135



## KATADYN SURVIVOR 35 WATERMAKER

The Survivor is a must for all sea-going vessels and is the most widely used emergency desalinator. It is used by the U.S. and international forces. It is able to produce 4.5 liters of drinkable water per hour. These are unused U.S. government surplus.

Reconditioned by Katadyn **\$950.**  
Compare to factory new price: \$1,995.

For more information or to place an order, please call one of our sales reps.

Equipment Parts Sales  
In the U.S.: (800) 417-2279  
Outside the U.S.: (717) 896-9110



## QUALITY CUSTOM CRUISING SAILS FOR LESS!



**MAINSAILS  
MIZZENS  
STAYSAILS  
HEADSAILS  
SPINNAKERS  
SAILCOVERS  
STRONGTRACK**

(510) 521-2353 • [leesailsnc@yahoo.com](mailto:leesailsnc@yahoo.com)

2021 Alaska Packer Pl. • Grand Marina • Alameda, CA 94501

**SAILMAKER TO THE WORLD SINCE 1947**



**33-FT HOBIE, 1984.** Alameda. \$13,000. Fixed keel version. Fast and Fun, this is a great short-handed performance boat. Harken roller-furler, self-tacking jib, main-sail, lazy jacks, 6 other bags of sails, brand new bottom job. Custom cockpit well with custom outboard motor mount. Honda 4-stroke outboard - good condition, runs well. Priced under market value because inside of boat needs some TLC. (415) 999-0509 or sean@svendsens.com.

**34-FT HUNTER, 1984.** Sausalito, CA. \$29,000. If you can find a cruise ready sailboat at this price, take it! This is a 34-ft sailboat that could leave for Mexico tomorrow. Just fill up the water and fuel and turn left after leaving the Golden Gate. Any takers? This is an excellent first time boat that is rigged for singlehanded and operates well under all conditions. I love this boat, but I am now the owner of another boat, so it is time to sell. The boat is priced to move. Photos and a detailed description of the boat can be found at: <http://witchdoctorsailboat.webs.com>. (415) 497-6116 or medicrene@yahoo.com.



**33-FT HANS CHRISTIAN, 1980.** San Diego. \$119,000. Change of plans! Fully refitted for S. Pacific voyage. New Yanmar, electronics, watermaker, sails, rigging, batteries, solar, canvas, dinghy and spares. Loads of cruising gear. Ready to go. (619) 319-0136.

**34-FT DUFOUR, 1975.** F-204 Berkeley Marina. \$32,000. Rare to West Coast excellent racer/cruiser, in a 1975 way. This boat is in excellent shape for her age. Two large hatches seal this boat up for ocean sailing and yet she has over 6 feet of head room below. The perfect live/sail combination. Reluctantly for sale. Call Peter to view. (510) 910-2886.

**32-FT PEARSON VANGUARD, 1964.** Ventura. \$10,000. GPS, radar, wind generator, Kyocera solar panel w/ controller, depth, autopilot, propane range, refrigeration, strong diesel. Good sails, dodger, ground tackle. Rigging in good condition. Needs painting, but completely sailable; used every weekend. (805) 570-9883 or svdaedalus2005@yahoo.com.

## 36 TO 39 FEET

**38-FT HUGHES, 1970.** Monterey, Ca. \$21,000/obo. Canadian built S&S design. Sound hull, low hours on nearly new diesel engine. Sails nicely, needs TLC & newer/upgraded equipment. (831) 915-4984 or coffina@sbcglobal.net.

**36-FT CATALINA, 1983.** Alameda. \$44,950. New dodger, main, wheel, canvas, furler, fuel tank, shaft, radar, GPS, jib, interior cushions, head, standing rigging. Bimini, inverter, Autohelm, 4 batteries, VHF, cockpit cushions, stern seats, shower, refrigerator, sleeps 7, diesel 2670hrs, pressurized water, excellent condition. (510) 731-4259 or jandersonwj@sbcglobal.net.



**38-FT X-YACHT 382 SLOOP, 2002.** Croatia. \$149,000/offers. Dry stored near Dubrovnik, Croatia. Being sold by original owner. Recent health issue forces sale of this beautiful 38-ft sailboat. 2 cabins, head, galley, etc. An absolutely turnkey boat in pristine condition loaded with extras including Spectra watermaker, etc. Ready to sail Croatia this summer or take you anywhere in Med, Europe, or across the ocean. Lowest priced late model X-Yacht 382 available anywhere in world. (415) 850-8110 or nizzaneoz@aol.com.

**36-FT CATALINA, 1983.** Point Richmond. \$44,000. Radar, chartplotter, autopilot, speed and depth by Raymarine. New head, new stereo, new bilge pumps, new Balmar alternator, new batteries. Lots of sails, dinghy, OB, dodger, bimini, VHF and more!!! (415) 309-4476, (415) 883-5721 or bob@lesnetrealestate.com.



**38-FT BLUEWATER INGRID, 1977.** Fortman Marina. \$15,000. Bluewater Ingrid project boat, beautiful teak interior. Former liveaboard. Great hull, beautiful boat with work. Full stats and pictures available. donalddhardy@yahoo.com.



## OFFSHORE PASSAGEMAKING INSTRUCTION IN THE SOUTH PACIFIC

John & Amanda Neal are dedicated to providing hands-on, documented instruction aboard their Hallberg-Rassy 46 *Mahina Tiare III*, drawing on their combined 502,000 miles and 66 years of experience.

[www.mahina.com](http://www.mahina.com) • (360) 378-6131

*Going Somewhere?* **Mexico • Caribbean • South Pacific**

Stop by our office and take a bundle of *Latitude 38* along with you.

*We promise you'll be a hero for sharing them with other cruisers!*

**Latitude 38 • 15 Locust Ave • Mill Valley, CA • (415) 383-8200 • Open M-F 9-5**



**38-FT CATALINA 380, 1998.** Alameda. \$99,000. Exceptionally clean inside and out. Well equipped. Professionally maintained. New bottom 01/10. Priced for quick sale. Call: (209) 612-8128.

**37-FT RAFIKI 37, 1978.** Fortman Marina. \$49,500. Solid blue water cruiser or liveaboard. Newer LPU, wiring, fuel tanks, electronics, cushions. Diesel heater, new holding tank and lifelines, windlass, inverter, epoxy bottom. Offered below 2009 survey. <http://alsyachts.com>. (510) 521-5400 or [Fox@ebmud.com](mailto:Fox@ebmud.com).

**39-FT FREYA IN STEEL, 1974.** Oxnard, CA. \$29,900/obo. Freya Halvorsen 39 steel sloop. Insulated, rebuilt 85hp Ford diesel. Autopilot, radar, GPS, fridge, shower, hot water. Hood roller furling, hydraulic windlass, sounder, dodger, refurbished aluminum mast/boom. 8-ft dinghy. (805) 200-6089 or [traim69@hotmail.com](mailto:traim69@hotmail.com).

**36-FT HUNTER 356, 2003.** Alameda. \$92,900. Beautiful boat. Very spacious interior. New bottom paint. Save thousands over buying through a brokerage. See all details and photos on the listed web page. <http://web.mac.com/laynegalloway>. (801) 419-4100 or [laynegalloway@msn.com](mailto:laynegalloway@msn.com).



**36-FT ISLANDER, 1975.** Clipper - Saualito. \$29,900. Great partnership boat for cruising or racing! Fully race equipped including 2 spinnakers, extra winches and halyards, hydraulic backstay and boomvang. Roller furling jib and recent mast re-build for \$11K. Recently rebuilt Atomic 4 gas engine. Start having fun on the Bay! Contact Dick Keenan at (415) 378-9830 or [dick.keenan@gmail.com](mailto:dick.keenan@gmail.com), or Desmond Hayes at 415-644-5981 or [dhayes@treanllc.com](mailto:dhayes@treanllc.com).

**38-FT HUNTER 380, 2000.** Alameda Marina #350. \$89,500. Priced to SELL. Radar, autopilot, Yanmar, chart plotter, electric winch, inverter, good shape. Email for pics and spec sheet. (916) 817-0081 or [pbpme@hotmail.com](mailto:pbpme@hotmail.com).

**36-FT ISLANDER FREEPORT, 1981.** Half Moon Bay. \$50,000. Plan B interior, new mattress, Froil sleep system. 45hp Pathfinder diesel, rebuilt 2003, many spares. Last haul-out/survey 2008. VHF, radar, depth, speed, main good, 135 jib OK, dodger, bimini, more. (650) 560-0260 or [hmbdave51@yahoo.com](mailto:hmbdave51@yahoo.com).



**38-FT KETTENBURG, 1956.** 3 Available. "Nice boat!", "Beautiful boat!", "Gorgeous boat!" heard many times from other boaters during every sail. Enjoy character, admiration, and fantastic sailing while sustaining the heritage. Details at: [www.sailk38.com](http://www.sailk38.com). (916) 847-9064 or [steve@paradigmpilgrim.com](mailto:steve@paradigmpilgrim.com).

**37-FT CREALOCK, 1980.** Monterey. \$55,000. Cutter. Ballenger tabernacled mast. New Yanmar w/saildrive, radar, GPS, easy access to all systems, 70gal diesel, 3 watertight bulkheads. Not in yacht condition, needs finish work. Great little sailing ship. Price firm. [ddatpbio@gmail.com](mailto:ddatpbio@gmail.com).



**39-FT CAL, 1971.** Oceanside, San Diego. \$40,000. New professional racing bottom, just splashed Nov 5, '09. Great racing inventory, new 3/4 oz. Ullman spinnaker, double spreader tall rig. Gas engine. Good shape and fast. <http://knot-a-clew.com>. (949) 280-6220 or [granahan@cox.net](mailto:granahan@cox.net).

**37-FT HUNTER, 1982.** Hidden Harbor, Rio Vista. \$29,900. Cutter rigged, Cherubini designed, Yanmar diesel, dodger, autopilot, lines aft, cruise vet, Achilles dinghy with dinghy tow system, 18hp Johnson. Hauled 5/09, new rigging 6/09. [www.mysailboatforsale.com](http://www.mysailboatforsale.com). (775) 721-5221 or [wh2ojake@yahoo.com](mailto:wh2ojake@yahoo.com).

**36-FT UNION - CUTTER RIGGED, 1986.** Oregon \$110,000. Beautiful documented sailboat w/large salon and separate shower. New Isuzu diesel engine ('03 - 200 hrs). Full cockpit enclosure. Great liveaboard. Consider partial trade for West Coast property/condo. See more at [www.ablboats.com/details.php?id=81027](http://www.ablboats.com/details.php?id=81027). [suzieandpete@msn.com](mailto:suzieandpete@msn.com).



**37-FT TAYANA, 1979.** Richmond. \$68,000. *Tricia Jean* spent 2004-2006 cruising the South Pacific and is ready to go again. She's well equipped, comfortable, fast and easy to handle. Details available at website: <http://dbsail.org/TriciaJean>. (559) 970-9858, (559) 960-5085 or [Dan@dbSail.org](mailto:Dan@dbSail.org).

**39-FT FREYA, 1978.** San Rafael. \$68,000. By Gannon Yachts. Yanmar, Monitor windvane, dodger, ProFurl, SSB. New in 2007: standing rigging, dodger, radar/chartplotter, Force 10 range, Spectra watermaker, fuel tanks and lines, batteries, galley range, cushions recovered. (415) 717-5815 or [jellykell@hotmail.com](mailto:jellykell@hotmail.com).

**36-FT BENETEAU 361, 2002.** SF Marina West Basin. \$118,000. Bristol, loaded, custom, all electronics, recent haul-out and bottom paint + coveted SF Marina berth. Will consider lease or non-equity partnership. (415) 771-0741 or [Bob@TandlerSF.com](mailto:Bob@TandlerSF.com).

**CATALINA 380, 1999.** Alameda. \$116,000. Cruise equip, electric halyard winch, SSB, watermaker, cruising spinnaker, radar, full instruments, Espar forced air heat, increased battery capacity, Winslow liferaft, EPIRB, solar panels, new canvas. (209) 634-8752, (209) 988-0616 or [laniki99@aol.com](mailto:laniki99@aol.com).

**37-FT JEANNEAU SUN ODYSSEY.** 2002. Newport Beach. \$109,000. Autopilot, bimini, Navtex World Weather radio, fresh bottom, original owner. (808) 741-1908 or [marshallkagan@yahoo.com](mailto:marshallkagan@yahoo.com).

**36-FT BENETEAU 36.7, 2005.** Port Angeles, WA. \$140,000 or ?. Beautiful 36.7, all cruising amenities. Shows as new, see pics and details at website: <http://beneteau367forsale.com>. (360) 452-1110, (360) 460-1014 or [bill@cpifiber.com](mailto:bill@cpifiber.com). 54 West Misty Ln. Port Angeles, WA 98362.

**CAL 2-39, 1978.** San Diego. \$55,000. Great for racing/cruising. Major Upgrades: 2009 wiring overhaul, new fuel tank; 2006 new upholstery throughout; 2004 new windpoint instrument; 2003 rebuilt engine. Maintenance history and pictures available. (858) 484-0186 or [vsnell@san.rr.com](mailto:vsnell@san.rr.com).

**36-FT SLOOP, 1975.** Marina Bay Yacht Harbor, Richmond, CA. \$30,000. Good running condition, ready to sail. Survey report from 2009 available. Contact Butch at Tradewinds Sailing School and Club. (510) 232-7999, (510) 415-2747 or [butch@tradewindssailing.com](mailto:butch@tradewindssailing.com).

## 40 TO 50 FEET



**41-FT HUNTER A.C., 2002.** Bay Area. \$149,900. 2 GPS chartplotters, radar, wind/speed/depth/auto, generator, flat screen plus much more. Cruiser ready and low hours. Fresh bottom job, August '09. (530) 242-1064, (530) 941-0738 or [amylesliehomes@yahoo.com](mailto:amylesliehomes@yahoo.com).

**40-FT HC CHRISTINA, 1988.** Peninsula. \$129,000. Nice, sails beautifully, modern underbody, new bottom paint, Yanmar 4JHTE. New holding tank, ST winches, anchors, Cape Horn, watermaker, older electronics, plans changed - too big for day sailor. (650) 563-9686 or [HCchristina40@gmail.com](mailto:HCchristina40@gmail.com).



**40-FT PETERSON IOR, 1979.** Singlar Marina, Guaymas, Mexico. \$90,000. Alum. hull, Pathfinder 50, watermaker, electric windlass, 66 Bruce, ProFurl, hard vang, spinnaker/whisker poles, full battens 3 reef main, strong track, 5 headsails, boom brake, winches-2 3-speed, 5 self tailing, radar, GPS, depth sounder, autopilot, windvane, 2 solar panels, 100 amp alternator, 8 AGM, 2 inverters, stove/oven, Lavac head, refrigerator-7.2 cubic ft. (435) 513-1556 or [s.blues1@yahoo.com](mailto:s.blues1@yahoo.com).



**NAUTICAT 44, 1983.** Blaine, WA. \$165,000 - REDUCED. Perfect Pacific Northwest/bluewater cruiser. Berthed in gorgeous San Juan/Canadian Gulf Island cruising grounds. Cutter-rigged ketch. Inside/outside steering. Queen walk-around. Swim platform. See blog for pictures, specs, contact information. <http://SailingSojourner.blogspot.com>.

### SMALL AD, SMALL PRICES • RIGGING ONLY

Standing and running rigging, life lines, furling gear, winches, line, windlasses, travelers, wire and terminals, blocks, vangs, and much more.  
 ~ ~ ~ Problem solving and discount mail order are our specialties ~ ~ ~  
[www.riggingonly.com](http://www.riggingonly.com) • (508) 992-0434 • email: [sail@riggingonly.com](mailto:sail@riggingonly.com)

**For the best - and most exposure - of your classified ad...**  
 submit your ad safely online at: [www.latitude38.com](http://www.latitude38.com).

*Classy Idea!*

Your ad will be posted online within two business days, appear in the next issue of the magazine, and remain online until the following issue is released.



### PROFESSIONAL DELIVERY CAPTAINS

San Diego based, USCG Master 100 GT. Sail and power. ASA-certified instructional deliveries. Pacific Mexico and Baja Bash specialists.  
[davidhbrotherton@yahoo.com](mailto:davidhbrotherton@yahoo.com) • [www.boatdeliverycaptain.org](http://www.boatdeliverycaptain.org)  
 • (619) 913-7834 •

### COMPLETE MARINE WOODWORK

Design / Restoration • Expert European Craftsmanship • Interior / Exterior Repairs / Maintenance • Marine Windows & Frame Replacement  
 Wood & Dry Rot Repairs • Varnish Work • Marine Painting  
**References Available • Reasonable Rates • Call (415) 331-6718**



**eMarine Systems**

Solar PV / Wind Generators  
High Output Alternators  
Low Power Refrigeration  
Inverters/Chargers/LED's

Located in the heart of Fort Lauderdale's Marina Mile District shipping worldwide.  
Authorized Air X/Air Breeze/Whisper repair center

[www.eMarineSystems.com](http://www.eMarineSystems.com)  
salesinfo@eMarineSystems.com  
954-581-2505

## We care about sail care!



**San Francisco Service**  
773 Andersen Drive, San Rafael, CA 94901  
T: 415-453-2142 M: 510-333-4644  
Hours: 8-5 M-F, Sat. by appointment  
SAIL CARE ■ SAIL COVERS ■ YACHT COVERS ■ FLAGS ■ CRUISING PRODUCTS

**CERTIFIED SAIL CARE**

**NORTH SALES**  
Faster by Design  
[www.northsails.com](http://www.northsails.com)

# MARINE ENGINE CO.

WESTERBEKE Universal BETA MARINE  
DIESEL MARINE ENGINES

LICENSED DEALER FOR ABOVE

PERKINS • YANMAR • ATOMIC 4 • VOLVO

**CALL NOW FOR LOW ENGINE QUOTES**

- Engine Sales, Service and Parts
- Engine Repowering and Rebuilding
- Complete Marine Engine Service



**(415) 332-0455**

# Mathiesen Marine

For all of your electronics and electrical needs

Sales & Installation of all major brands of marine electronics

Electrical system Troubleshooting & Repair to ABYC Standards

Corrosion issues, Inverters, Battery banks

**imtra** Imtra LED Lighting Dealer

3300 Powell Street, Emeryville  
(510) 350-6622 [www.MathiesenMarine.com](http://www.MathiesenMarine.com)

**ABYC CERTIFIED MASTER MARINE TECH**  
MARINE ELECTRICAL  
MARINE CORROSION  
MARINE SYSTEMS  
ABYC STANDARDS

**47-FT VAGABOND KETCH, 1984.** Coronado, San Diego. \$165,000. World class cruiser. Sleeps 7. Two forward w/enclosed head/shower. Main saloon has two L-shaped settees. Private cabin starboard. Galley midship portside. Queen berth aft w/head/separate shower/tub. (949) 439-5679 or bobtreve@cox.net.

**45-FT HANS CHRISTIAN 38 MK II, 1985.** Savannah, Georgia. \$100,000 motivated. New epoxy glass hull, shaft, MaxProp, cutlass and stuffing box, 300' of 3/8 HT chain primary, 100' 3/8 HT on 300' rode secondary ground tackle from Svendsen's Aug. '09, new keel cooled Frigobote unit, new LectraScan. Raymarine radar and chartplotter. Two mains-one full batten, 130 jib, staysail, storm sail, inner forestay blooper sail. Classic beauty. Ready for Med or Fiji. (404) 354-3855, (770) 710-7079 or joe\_millsaps@yahoo.com.

**40-FT CALIBER LRC, 1998.** Mazatlan. \$209,975. Well cared for and fully equipped with electrical and electronic gear. Rare on the West Coast. This is a great cruising boat. Will be in Mexico through the summer. Email for details. (916) 806-6181 or mmcn@jps.net.



**47-FT CUSTOM STEEL BOAT, 1990.** Lankawai, Thailand. \$120,000. The Pearl Hunter is for sale. This rebuilt, custom steel schooner has storage for more than 30 surfboards, an ice box with a capacity of 1000lbs, watermaker, custom hatches, stainless steel railings, custom dodger, watertight bulkhead, brand new stove and interior. Ready to sail to the Mentawai Islands or sail around the world. The hull has been almost completely rebuilt, water tanks rebuilt, hydraulic fishing reel. Recent survey and haul out. (808) 203-7262 or krlit@hotmail.com.

**43-FT CLASSIC CUSTOM SLOOP.** \$300,000 FIRM. Thoroughly restored (2009) to the highest yacht standards (think Hinckley, but better). True performance world cruiser. All new engine, sails, electric winches. Massive refit and upgrades - open checkbook. Elegant design with the finest gear. Must see and sail her. New to the Bay, ready for world cruising. (415) 987-1942 (cell) or (415) 868-2940 (H).

**J/40, 1986.** Flathead Lake, Montana. \$99,000. SSB, watermaker, radar. New VHF, roller furling, B&G inst. Pictures/specs available. (406) 253-5566 or j22racr@hotmail.com.



**44-FT TANTON CUTTER RIG, 1983.** Marina del Rey, CA. \$120,000. Two-time Baja Ha-Ha vet. Taiwan canoe stern cutter Jambo. Beautiful new teak decks 2007. Perkins M65 diesel 2004. North Sails 2009. Re-rigged 2004. Topsides repainted 2004. Bottom barrier and anti-fouling 2010. Well equipped, solid, serious cruising vessel just back from 5 years in Mexico. You can be ready for this year's Baja Ha-Ha. [www.rbyachts.com](http://www.rbyachts.com). (970) 948-6834 or evangull@sopris.net.

**44-FT KELLY-PETERSON, 1977.** \$100,000. Extraordinary. Purpose built for life in the tropics. Green power keeps systems running while others are running their motors. Refit 2008: solar, LED lights, big alternator, big batteries. Most beautiful boat in any anchorage: new canvas and new paint in Herreshoff-style palette. New rig, new electronics, new electrical system, new plumbing, custom features. Full set of sails, spinnaker and gear. Just hauled. Baja Ha-Ha '08, Puddle Jump '09. Details at: [www.thinwolfadventures.com](http://www.thinwolfadventures.com). Contact Mike. (509) 860-9614 or wardski@thinwolfadventures.com.

**50-FT FD-12, 1981.** Mexico. Unsinkable 50-ft cutter, AK/Mexico/SoPac vet. Superb galley in pilothouse: generous counter space, good daylight & view. Berths for 5-6 in 2 staterooms forward and master stateroom aft (privacy for parents w/children or guests). [www.svdaydreamer.com](http://www.svdaydreamer.com). Call (928) 717-8812.



**50-FT HOLLMAN CUTTER, 1989.** Marina Bay YH, Richmond, CA. \$189,900. Major refit '03 from keel to masthead, LPU, barrier, rigging all redone. All sails furled from cockpit for safety, easily single- or doublehanded. SSB, autopilot, VHF, GPS, elec windlass w 300' chain, lrg chart table, lrg galley, reefer w/sep freezer, two staterooms, two heads. 280 water, 85 diesel. Strong, fast, cruising cutter w/ NO TEAK. Bottom paint 4/15/10. Call or email for more info. (520) 906-4351 or franke2u@aol.com.



## MARINE SURVEYOR

Sharpe Surveying & Consulting. SAMS Accredited Marine Surveyor.  
Serving the San Francisco Bay and Delta.  
**RSharpe@SharpeSurveying.com • (510) 337-0706**

### Latitude 38 Mexico Crew Party

Wednesday, September 8 • 6-9 pm • Encinal Yacht Club • Alameda  
\$7 entry fee • Munchies • No-Host Bar • Door Prizes • Demonstrations  
More info: [www.latitude38.com](http://www.latitude38.com) Crew List/Next Party or call (415) 383-8200

**42-FT VALIANT, \$295,000.** Never used. Never in salt water. Quantum sails, ProFurl on jib, autopilot, microwave, Westerbeke diesel. Boat is as new, location Valiant factory in Texas. Contact Dick May. (480) 513-7136 or boatseller@aol.com.



**40-FT PETERSON, 1980.** Sunroad, San Diego. \$49,000. Doug Peterson design offshore blue water racer/cruiser. We bought the boat in 2003 in San Diego and sailed her to France. After 1 year of refit and several regattas in the Mediterranean, we came back across the Atlantic (2007), making the crossing in 13 days. She has an open plan design with space to sleep 8-10 crew. Ideal for someone looking to do some racing, but also with serious offshore capability. (619) 573-3525 or mark.richards@gmail.com.



**50-FT HERRESHOFF CARIBBEAN, 1978.** Napa Marine. \$199,500. 14.5' beam, 6' draft, Perkins 6-354, radar/AP/SSB-Ham, VHF, Probe, 6-person raft, spares, tools, dinghy/motor. Fresh interior refinish. Not a fire sale. Serious inquiries only. [www.sailboatlistings.com](http://www.sailboatlistings.com). (707) 834-4798.



**40-FT PASSPORT, 1985.** Anacortes, WA. \$169,000. I am the original owner that had this boat custom built with many extra features, such as insulated hull, removable headliner, and much more. Beautifully maintained, over \$100,000 spent to restore her to near Bristol condition, including full Sterling paint, bright work, refinishing the teak decks, bottom paint, Raymarine instruments, engine work, plumbing, and much more. Included is a 10-ft RIB dinghy with a 4hp Tohatsu 4-stroke engine. (206) 295-2049 or 1985passport40@gmail.com.



**42-FT CATALINA MKII, 2001.** \$167,000. Good racer, great cruiser, 2 staterooms, 2 heads, electric halyard winch, RL80C GPS/chartplotter/radar with 10" color monitor, Waltz radar leveling system, Navtec hydraulic backstay, 3-blade MaxProp. 2 mains, 2 jibs, 3 kites, spinnaker pole stowed on mast. For additional upgrades and photos go to website: [www.beniciayachtclub.com/boats/glory.html](http://www.beniciayachtclub.com/boats/glory.html). Or call Rob, (707) 746-1128.

**40-FT VALIANT, 1980.** Currently located in Scotland. Offers over \$70,000. US documented and VAT free in Europe. Sailed from San Francisco by owners. Fully equipped for cruising. Send email for photos and more info. wcz5502@sailmail.com.



**42-FT WESTSAIL, 1980.** San Pedro. \$105,000. Center cockpit cutter rig with teak decks. Extensive sail inventory and reliable Ford Lehman diesel engine (1050 hours). 350 gallons water, 100 gallons diesel, 60 gallons holding. Virgil radar, Benmar autopilot, Heart inverter. Maxwell electric windlass w/ two plow anchors and 325' high-test chain. Dickenson diesel stove/oven and coldplate Technotics refrigeration. Boat is in great condition and ready to go anywhere. (310) 991-1119 or elpescador47@gmail.com.



**40-FT CHOATE, 1980.** Delta. \$35,000/obo. Fun Boat. 2002 refit. 20hp Volvo. (ST60 speed, depth, multi, GPS chartplotter). Harken roller. Cockpit compass p/s. 10 cockpit winches. SS rod rigging. Rigid vang. Hydraulic backstay. 12 sail bags. Maple interior, etc. (707) 374-5467 or propspec@yahoo.com.

**41-FT MORGAN CLASSIC MODEL, 1991.** San Carlos, Mexico. \$98,000. Primo condition. Equipped and ready to cruise. Center cockpit, great liveboard, must see to appreciate roominess. Recent survey. See blog for equipment list and current photos. <http://sailboatvagari.blogspot.com>. (520) 825-7551 or email stanstrebig@gmail.com.

## 51 FEET & OVER



**55-FT FIBER STEEL, 1980.** River View Marina, Sacramento. \$Make offer/Must sell. 72' LOA, 16' beam, F/C, 671 main engine with 300 hrs. 15KW gen, 1100 gals. diesel, 500 gals. fresh water, ketch rig. New sails, 6'6" head room, sleeps 8. Dinghy and new electronics, 385' 3/8 ht chain, 2000 lb windlass, 2 heads, shower, ice maker, 2 refrigerators/freezers. Great liveboard with liveboard slip. 7 minutes to downtown Sacto. Possible trades? Health forces sale. (916) 208-4141 or seahawk2mexico@gmail.com.

## CLASSIC BOATS



**CANAL BARGE IN FRANCE.** Canal Du Midi, France. \$290,000/asking. Sacrifice... a fraction of her value. A wonderful turn of the century iron vessel, 100-ft built 1895. Converted to hotel barge in the 1970's. Refurbished in 1999 and 2000, was a well known and very successful luxury charter barge in southern France for more than 10 years. Now ready for your adventure or use as apartment, etc. In excellent condition. Divorce forces sale. Reasonable offers considered. Please call or email for further info, photos, etc. (415) 336-3367 or nizzaneoz@aol.com.

**25-FT CHEOY LEE VERTUE, 1956.** Alameda. \$12,500. #138, Laurent Giles' masterpiece, 9000 lbs of solid craftsmanship. Copper riveted teak planking. Newer epoxy/plywood deck. Low hour 12hp Westerbeke diesel. Vertue info at website: <http://vertueowners.org.uk>. (707) 832-6223 or casejames@fastmail.fm. Ready2sail!



**38-FT KETTENBURG, 1956.** Monterey. \$20,000. Well-loved, vintage 1956 #35 sloop. True classic. Monterey mooring available. New ribs, rigging, deck. Custom covers. Holding tank and electric head. Full galley and comfortable liveboard. Contact Billy. (831) 840-2417 or Kimbabwe99@yahoo.com.

## MULTIHULLS

**34-FT GEMINI 105M, 2000.** Pt. Richmond. \$125,000. Hull #660. World's most popular catamaran, comfortable cruise equipped with 3 headsails, traveler, davits, and more. 14' beam fits standard berths. Send email for list of equipment. Will consider trade down. (510) 367-0500 or jadawallis@hotmail.com.



**30-FT IROQUOIS, 1974.** Alameda. \$29,000. PRICE REDUCED! Fast spacious catamaran, sleeps 8, four separate cabins. Bluewater capable. Draws 18"5', leeboards and rudders rebuilt. 13.6 beam, 25hp Honda, 20 hours, Harken furler. Needs cosmetics. Great owner's group. (510) 593-8697 or ssnick@gmail.com.



**43-FT CATANA 431, 1999.** Alameda. \$399,000. Sail the Bay, Mexico, or the world safe, comfortable, fast and in style! Well maintained, new North jib, big stick carbon rig, bow sprit and everything you need for cruising. cat431sf@gmail.com. [www.onourboat.com/tramuntana](http://www.onourboat.com/tramuntana).

**33-FT EDEL, 1986.** Panacea, Florida. \$46,000. Turn key for coastal cruising, 3 jibs, spinnaker, mainsail, safety gear, dinghy, 2 ground tackles, 9hp Yamaha outboard, autopilot, Raytheon instrumentation, well maintained. (415) 419-6893, (530) 544-2101 or brunracing@hotmail.com.



**Get the Reliable, Powerful Wheel Pilot**

Quiet & Dependable • Affordable • Built for Immersion  
Easy Owner Installation • Low Power Consumption

831-687-0541

[www.cptautopilot.com](http://www.cptautopilot.com)

*Latitude 38 eBooks*

FREE ★ AVAILABLE WORLDWIDE ★

[www.latitude38.com/ebooks.html](http://www.latitude38.com/ebooks.html)

**MULTIHULL YACHT DESIGNER • MARINE SURVEYOR**

John R. Marples, CMS • Certified, National Association of Marine Surveyors  
Multihull Design Specialist • Pleasure and Commercial  
Design office for *Jim Brown Searunner, Seaclipper & Constant Camber Multihulls*  
[www.searunner.com](http://www.searunner.com) • (707) 343-1378 • [marplesmarine@comcast.net](mailto:marplesmarine@comcast.net)

boat bottom scrubbing & more . . .

415.331.7215 [william@gotzinc.com](mailto:william@gotzinc.com) [www.gotzinc.com](http://www.gotzinc.com)



*A Sailor's  
Consignment  
Chandlery*

Official  
Sponsor  
2010  
BAJA  
HA-HA

**510-769-4858**

Located at Grand Marina

[www.bluepelicanmarine.com](http://www.bluepelicanmarine.com)



## Save Your Aft!

Using one of our 1900+ patterns or your own pattern, let our craftsmen create a comfortable, durable, and stylish set of all-weather cushions for your cockpit. Find your custom, closed cell foam cushions at [www.bottomsiders.com](http://www.bottomsiders.com)!

**BottomSiders**

**BottomSiders**  
2305 Bay Avenue  
Hoquiam, WA 98550

Call Toll Free: (800) 438-0633  
[cushions@bottomsiders.com](mailto:cushions@bottomsiders.com)  
Fax: 360-533-4474

**Bilge Steam Cleaning Oil Changes**

Professional service at your slip!!!

**MarineLube** 877 744-2244  
[www.MarineLube.biz](http://www.MarineLube.biz)



**Fuel Polishing**

**Tank Cleaning**



## MORE ENERGY!

### KEEP BATTERIES CHARGED!

- KISS wind generators
- Solar panels and MORE

### USE BATTERIES EFFICIENTLY!

- LED lights
- Engel fridge/freezers
- Wonder Wash and more



[www.svhotwire.com](http://www.svhotwire.com)

**727.943.0424**



**38-FT LAGOON 380, 2003.** San Diego. \$249,000. (2) Yanmar 3GM30's. Loaded example of the most popular cruising cat, ever! Crazy fast downwind - sailing flat! No "rolly" anchorages! Just returned from Florida-Caribbean-Mexico cruise. Most versatile 4-cabin version (sleeps 8, or more commonly 4 singles. Remember, you can convert a cabin for storage much easier than a locker to sleeping!) All the cruising "toys": solar panels, wind generator, watermaker, inverter, Sirius stereo, DVD-TV, SSB w/Pactor modem, (2) Raymarine color displays w/radar, chartplotter & AIS. Raritan (2) electric heads. The perfect cruiser? Perhaps. Too much to list here. Check website for more! [www.YoungerGirl.org](http://www.YoungerGirl.org). (503) 320-9859 or [CapitanoMarco@yahoo.com](mailto:CapitanoMarco@yahoo.com).



**34-FT GEMINI, 2000.** Ventura Harbor. \$121,000. The Gemini catamaran is a very capable and comfortable offshore cruiser. Three staterooms-sleeps 8. New engine, new bottom paint. Ideal for entertaining, coastal cruising, and longer passages. Many upgrades, email for details. (805) 217-3939 or [dick.mahoney@gmail.com](mailto:dick.mahoney@gmail.com).



**30-FT AUGNAUGHT, 1995.** Moss Landing, CA. \$26,500. Mono-hull monotony got you down? Looking for something a little faster? Want to fly across the bay with your hair on fire screaming, "yeeehaaaaah!"? Zoom just may be the medicine you need, and as a trailerable boat you will have access to many fresh water venues as well. The current owner needs to slow down for a while and wants it sold now! Hence the low price. This boat is ready to go now. Reduced from \$33,500 to \$26,500. (831) 247-7939 or [hawknest1@prodigy.net](mailto:hawknest1@prodigy.net).



**40-FT SEARUNNER, 1979.** Blaine, WA. \$80,000. Among best in class. Well designed, constructed, maintained, equipped. Veteran of five-year cruise 2001-2006. Refit and survey 2007. Sleeps six, 15 sails, 30hp diesel, radar, autopilot, windvane, watermaker, SSB radio, solar panels, wind gen, life raft, new paint. Awesome cruising boat. More at <http://searunner40seafire.wordpress.com/>. (360) 756-5004 or [svseafire@yahoo.com](mailto:svseafire@yahoo.com).

## POWER & HOUSEBOATS



**30-FT MAINSHIP PILOT 30 II SEDAN.** 2003. San Francisco Yacht Harbor Marina. \$135,000. Classic down-east look and almost maintenance free exterior. This low hour boat is in excellent condition and extensively outfitted for cruising. Details: <http://tinyurl.com/03pilot>. (415) 829-8775.



**55-FT 48 PASSENGER CATAMARAN.** 1978. San Francisco. \$69,000. Perfect liveaboard/cruising conversion. Fresh 5-year US Coast Guard Certified to 48 passengers. Twin diesel, 8kw generator. Selling because of the economy. Will need drydocking before entering back into commercial service. See more at: [www.rendezvouscharters.com/searaven.htm](http://www.rendezvouscharters.com/searaven.htm). (415) 543-7333 or [spinnaker.sailing@yahoo.com](mailto:spinnaker.sailing@yahoo.com).

**40-FT MARINE TRADER, 1976.** Oyster Point Marina. \$55,000 or best reasonable offer. Twin diesels, good condition, newly glassed decks. 2 heads, sleeps 4. Great for living, cruising, fishing. See photo and specs at website: <http://holdingbay.net/salsa>. Reduced price to sell. (650) 588-5432 or [jlevant@gmail.com](mailto:jlevant@gmail.com).

**37-FT PRIVILEGE, 2000.** Ensenada, Mexico. \$249,000. Owner's version fully equipped, ready to go, blue water catamaran designed by Marc Lombard. Highest build quality and finish, certified by Bureau Veritas as Class A Ocean vessel. More at: [www.summatrix.com/padma/?page\\_id=1422](http://www.summatrix.com/padma/?page_id=1422). Email [padmaforsale@summatrix.com](mailto:padmaforsale@summatrix.com).

**54-FT SAGAR 16 METER BARGE, 2002.** Central France. \$290,000. Custom built for all navigable waterways. 2 Brms, 2 bath. Complete inventory for comfortable cruising. See website for photos and complete inventory. Sagar has a two-year waiting list for new build. Owner financing. More at <http://web.me.com/cbroussard/Acadia/Welcome.html>. Email [pat1083@sbglobal.net](mailto:pat1083@sbglobal.net).







**65-FT WOOD CLASSIC, 1939.** Heavy built ex-trawler. GMC 12V-71, 21-kw generator. Full electronics. Lots of equipment. Ready to go. Would make great conversion. Will consider any reasonable offer. More pics/details: (707) 964-5423 or ancona@mcn.org.

**43.5-FT LABELLE TRAWLER.** \$115,000/asking. Sausalito outstanding view berth. Volvo diesels, 500 hours, 7.5 Onan. Roomy glass-enclosed sundeck. Full canvas. Large custom galley. Master with walkaround queen, tub + comfortable guest stateroom with large bed, head. Excellent workmanship/condition. Will sacrifice. May finance, rent or trade. (415) 999-5626.

**28-FT PROTECTOR, 2001.** Lake Tahoe. Beautiful center console Protector, 99% fresh water use. Two 225hp Yamahas, under 400 hours. Teak sole. Rear seat, GPS/chartplotter, VHF. Excellent condition and very fast. (530) 583-4000, (530) 518-8500 or GD@DorlandProperties.com.

## PARTNERSHIPS



**CATALINA 30 SHARE.** Only One Share Left. Sausalito. \$270/month. Docked in the best marina in the Bay, w/parking just steps to boat, 5 minutes to Bay sailing. Many upgrades: wheel/diesel/newer performance mast/spars, furling, MaxProp, GPS, spinnaker, new cushions. Share \$270 month for 7 days max/month. Photo is sistership. (415) 332-5442 or Leeloves2sail@hotmail.com.

**33-FT RANGER, 1977.** Clipper, Sausalito. \$7,000 1/3 equity partnership. Ideal Bay cruising sloop. Furling main/jib. Rigged for solo. Beautifully maintained. Congenial partners. Universal diesel. New transmission. \$133/mo 1/3 berthing. Article/review, see web page <http://latitude38.com/features/bomRanger33.htm>. (925) 595-0765.



**BENETEAU 393 PARTNERSHIP.** Sausalito. \$500. Clean, well maintained fast cruiser. Upgraded interior, winches, prop, diesel, full electronics, classic main, fully equipped. Qtr usage non-equity; may consider 1/8 or equity arrangement or sale. <http://marigotgroup.com/strider>. (415) 332-4401, (415) 331-4900 or 393@marigotgroup.com.



**ISLANDER 36, 1977 PARTNERSHIP.** Emery Cove Marina, Emeryville. 1/4 or 1/2 share, easy to handle Bay sailer and cruiser, active class association, \$300 per month for 1/4 share plus buy-in. (510) 654-3903.

**45-FT OCEAN ALEXANDER.** Partnership Pier 39, San Francisco. \$100,000. Selling 50% equity. Well maintained in long term subleased slip at Pier 39 Marina, San Francisco. Email for additional details/commitments regarding partnership. [fantasyrsox@aol.com](mailto:fantasyrsox@aol.com).



**BENETEAU 350, 1989.** South Beach Marina, San Francisco. \$17,000. 1/3 partnership for sale, boat in good condition, haul out this year. New sail and bimini covers. Great location, must see. Two complete sets of sails. Furling jib. (925) 640-4226 or r.d.green1@comcast.net.

**J/105 FRACTIONAL OWNERSHIP.** Alameda \$525/month. Available for day sailing/club racing. Loaded with options, immaculate condition. Monthly fee for full ownership privileges, zero hassle. (408) 218-4370, (650) 533-5336 or [stevecrawf@gmail.com](mailto:stevecrawf@gmail.com).



## SOUTH OF THE BORDER

**SAILBOAT CHARTER - SEA OF CORTEZ.** 7D/7N (bareboat or skippered), mini vacations, adventure sails. Experienced skipper/instructor. Discover the beauty of La Paz and the Sea of Cortez. Explore desert islands, swim with sea lions on a real cruising sailboat. More at [www.charter-baja.com](http://www.charter-baja.com). Email [charterbaja@yahoo.com.mx](mailto:charterbaja@yahoo.com.mx).



**CHARTER DIRECT & SAVE \$\$\$\$.** Owner's time available for discount charter. Beautiful Robertson & Caine 4600 cat, Hope, featured in Latitude 38. Based in beautiful Belize. Book direct and save big bucks. [pettyd@comcast.net](mailto:pettyd@comcast.net).

**HAWAII MINI-VACATION AND SAILING** getaway under \$750/week! Liveaboard beautiful 75' yacht in heart of Paradise. Experience tropical lifestyle of your dreams. Customized vacation plan balances tradewind sailing with island activities/amenities. Not a sailor? Kick-back/relax or learn from USCG captain. <http://hawaiisailvacations.com>.



**VALLARTA CATAMARAN CHARTER.** Puerto Vallarta. Low season rates! Come sail with us on famous HumuHumu in perfect Banderas Bay conditions. Full day, Long Weekend or Costa Alegre Discovery Cruise. Vallarta has it all! [www.catpv.com](http://www.catpv.com). (760) 681-7825, (760) 975-5850 or [info@catpv.com](mailto:info@catpv.com).



**PLAN YOUR MEXICAN GETAWAY NOW.** at the brand-new, gorgeous Cielo Y Mar condos. Located in Punta Mita, 35 minutes from Puerto Vallarta, available to rent from private owner. On the beach, 10 feet from the water, they offer spectacular views of ocean and mountains, the biggest infinity pool in the area, an endless beach, great surf breaks, great fishing, tremendous views of whales, bird life and the islands. While uncrowded and tranquil, just a five-minute walk to several waterfront restaurants. Choose from a spacious, beautifully furnished one or three-bedroom unit, or an amazing two-story penthouse with lovely shade trellis on the top floor. See details: [www.puntamitabeachfrontcondos.com](http://www.puntamitabeachfrontcondos.com). To reserve, call: Doña de Mallorca (415) 599-5012.

## TRADE

**SAILING MONTEREY: TRADE.** For Boat Work And/Or Slip. Monterey. \$Negotiable. Trade sailing with or w/o lessons. Crealock 37 in Monterey for boat work and/or slip fees. [ddatpbio@gmail.com](mailto:ddatpbio@gmail.com).



**BESTWAY 40 SANTA CRUZ, CA C-4.** \$115,000. Trade '84 Bestway 40 Trawler. Great liveaboard for an equal value sailboat. Santa Cruz berth C4. Large aft cabin, Espar diesel, heat, etc. (510) 506-4222 or [louzev@comcast.net](mailto:louzev@comcast.net).

## GEAR

**UNIVERSAL M25XPB 26HP DIESEL.** Inboard. Seattle area. \$5,000. Like new-149 hours. Currently installed in my sailboat in Winslow Wharf Marina (Bainbridge Island). Come see it run. Includes prop, shaft, panel, fuel filter, cooling system, throttle/shift control. \$5,000 FIRM or trade toward 30'+ 5th wheel/travel trailer. (360) 643-9113 or [jn5289@yahoo.com](mailto:jn5289@yahoo.com).

**SUNBRELLA.** Albany. \$8-11.50. Marine grade; Royal Blue, Blue/Dark Blue tweed, Pacific Blue, Grey, Beige, Toast (darker beige). 60" wide, \$11.50/yd. Grey/Black tweed. 46" wide, \$8/yd. Limited amount. (510) 525-6900, (510) 725-8616 or [kf6il@yahoo.com](mailto:kf6il@yahoo.com).

**STAINLESS DAVITS.** 9'-18' Paratech Paranchors 35-45 cruising anchors, windlasses (man-elec), rollers, MastMate, stainless ladder, lifting crane, BBQ's, Proline inverter, Avon dinghy, dive gear, Southcoast-Barient #26's, Monitor wheel adapter, storm jibs, headsails, rigging cutters, water separators, waterlift, harnesses, cruising library. (415) 497-3731 or [brad-low@sbcglobal.net](mailto:brad-low@sbcglobal.net).

**NORTH SAILS MELGES 24 SPINNAKER.** Power Zone Reacher. Scotts Valley, CA. \$2,000. All blue. Purchased in May '06, used once to win Delta Ditch race. Sold boat, sail no longer needed. New, this sail is around \$3,500. [timh@cruzio.com](mailto:timh@cruzio.com).

## PERSONALS

**ART PROJECT NEEDS CHARTER.** New York artist looking for a motorsailer headed to Tahiti or thereabouts to help complete around-the-world art project. Two passengers and two film crew. For details. (845) 687-7585 or [artdreams@nvi.net](mailto:artdreams@nvi.net).

**SailTime: The Hassle Free Alternative to Boat Ownership**  
Join SailTime for a non-equity membership on our 2011 Hunter 36 – no hidden fees – just \$695 a month.  
[www.SailTime.com](http://www.SailTime.com) • (415) 869-2861

**Need Crew? Latitude 38 Crew List A Boat to Crew on?**  
Visit our website and sign up as Skipper or Crew • It's Free  
Find out about our next Crew Party: Wed., Sept. 8, at Encinal Yacht Club  
More info: [www.latitude38.com/crewlist/Crew.html](http://www.latitude38.com/crewlist/Crew.html) or call (415) 383-8200

 **superwind.com** 

**J/105 FRACTIONAL OWNERSHIP**  
Available for day sailing/club racing. 'BoatShare by J/World' manages and maintains. Loaded with options, immaculate condition. \$525/month for full ownership privileges, zero hassle.  
[www.sailing-jworld.com/boatshare\\_for\\_members.htm](http://www.sailing-jworld.com/boatshare_for_members.htm)  
• (408) 218-4370 • (650) 533-5336 • [stevecrawf@gmail.com](mailto:stevecrawf@gmail.com) •

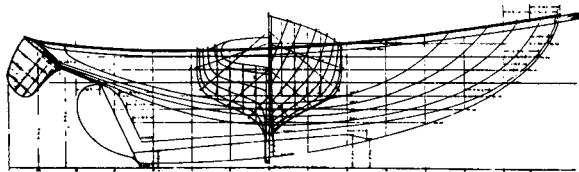

## MAKELA BOATWORKS

Family owned since 1948

**Wooden Boat Building • Repair and Restoration**

19280 South Harbor Drive • Fort Bragg, CA 95437

**(707) 964-3963**

email: howard@makelaboatworks.com • www.Makelaboatworks.com

## Ryan's Marine

*Specializing in Marine Electrical Services  
for Your Boat*

- Electrical system installations from inverters to electronics packages
- Troubleshooting of existing systems
- Dealer for the complete Balmar product line
- Head and holding tank installations



**(510) 385-3842**

Ryan Schofield  
Owner since 1997

email:  
rssailor@yahoo.com

## WEDLOCK, RAMSAY & WHITING

Marine Surveyors

Vessel surveys,  
consulting, deliveries.

Serving the  
Bay Area  
since 1980



[www.norcalmarinesurveyors.com](http://www.norcalmarinesurveyors.com)

**(415) 505-3494**

## Mexico Summer Savings

**ENJOY MARINA EL CID at just \$.30/ft. day**



*Complete, modern amenities  
in the heart of Mexico's lush  
tropical coastline.*

[www.elcid.com](http://www.elcid.com)  
011-52 (669) 916-3468  
gcevallos@marinaelcidmazatlan.com

*The Cruiser's Home in Mexico*

## MISCELLANEOUS

**PRIVATE CATAMARAN CHARTER.** Unique opportunity to sail with experienced bluewater World Cruisers aboard a high performance and immaculate Chris White Atlantic 42 sailing catamaran. [www.DKSail.com](http://www.DKSail.com).

**MARITIME DAY CELEBRATION.** Galilee Harbor 30th Anniversary. Saturday, August 7. 300 Napa Street, Sausalito. Flea Market, food, music, boat raffle. For info contact Galilee Harbor. More info at [www.galileeharbor.org](http://www.galileeharbor.org) or (415) 332-8554.

**AVON OCEAN 8 PERSON** Liferaft Valise. Healdsburg. \$2,500. Carried in Baja Ha-Ha #10. Not used. Stored since. Needs current service inspection. Size 29.13"L x 8.66"W x 19.29"H. Weighs 91 lbs. New \$3,369. (707) 473-0593, (707) 484-1696 or d419naples@comcast.net.

## TRAILERS

**SAILBOAT TRAILER FOR SALE.** Alameda, CA \$4,100. Dual axle sailboat trailer for fin keel boats 26-32 feet. GHW 7000lbs with adjustable bunks. Contact Britta. [brittaf@gmail.com](mailto:brittaf@gmail.com) or (510) 306-4635. 1526 Everett St., Apt E.

## CLUBS & MEMBERSHIPS

**AEOLIAN YACHT CLUB.** Membership Drive. Alameda. Initiation fee reduced to \$100 for July and August! Peaceful setting near Bay Farm Bridge. Attractive slip fees & dues; berths available. Private land, full workshop, tools, kitchen, bar, and social events. One hundred plus years of character; no suit and tie required! Active sailors and kayakers wanted. Join us for our Open House & BBQ, July 4th! Twitter: AeolianYC. Facebook: Aeolian Yacht Club. [www.aeolianyc.com/membershipapplication.htm](http://www.aeolianyc.com/membershipapplication.htm). (510) 523-2586, (916) 849-5715 or [aeolianyc@aol.com](mailto:aeolianyc@aol.com).

**SINGLE SKIPPERS AND CREW** of all abilities are invited to join the Single Sailors Association. Membership includes daysailing, raft-ups, invaluable onboard training, social events. Meetings held 2nd Thursday, Ballena Bay Yacht Club, [www.bbyc.org](http://www.bbyc.org). Social; 6:30 pm. Meeting; 7:30 pm. Guests welcome. [www.singlesailors.org](http://www.singlesailors.org). (510) 233-1064.

**PSPYC SEEKS NEW MEMBERS.** No initiation fee! Cost is often less than many marinas. Family Membership includes open bar, BBQ and galley at any time. Woodshop is available for projects. Not a "Blue Blazer" club. We cook and enjoy a dinner the 2nd Friday each month - guests welcome! 700 West Cutting, Point Richmond, next to KKMI, the property is secure and marina warm and calm. Open house and free BBQ Saturday, 10 July and 14 August. Call Letty or check website for more information. [www.pspyc.org](http://www.pspyc.org). (916) 595-7287 or [lkraus@ucdavis.edu](mailto:lkraus@ucdavis.edu).



## NON-PROFIT

**AMATEUR RADIO IN ONE DAY.** Sonoma Mountain Repeater Society. Going cruising? Are you Ham radio qualified? Technician class for local coverage. Next step - upgrade to general class for world wide coverage. Petaluma Senior Center, 211 Novak Drive, Petaluma, CA. Prep and exam fee, \$25. (707) 762-9414 or [wb6tms@arrl.net](mailto:wb6tms@arrl.net). More info at the website: [www.smrs.us/classes/classes.htm](http://www.smrs.us/classes/classes.htm).

## PROPERTY SALE/RENT



**AFFORDABLE LIVING IN TONGA.** "Safe-Haven, Retirement, 2nd Home". Private island ocean-view lots US\$3,850 each (not a typo)! Escape congested California and live your South Pacific island paradise dreams. Protected lagoon living aboard, while building a 'Cocomo Village' home. [www.tongaislandproperties.com](http://www.tongaislandproperties.com). [jg@TongaislandProperties.com](mailto:jg@TongaislandProperties.com) or (619) 347-2294.

**TOWNHOUSE WITH DOCK.** Alameda, Ballena Bay. \$625,000. Location! A 3 bedroom, 2 and a half bathroom townhouse. Great water views! Although interior was recently painted, this home is ready for its new owner to provide those special touches. Check out the natural light throughout, 30' deep water dock, & upper bedrm SF Bay views. Any reasonable offer will be considered. More info & photos at website. Listing agent Gregg Fujita, Harbor Bay Realty. [www.302tideway.com](http://www.302tideway.com). (510) 910-1800 or [gufujita@hbrinfo.com](mailto:gufujita@hbrinfo.com).

**WORKING WATERFRONT OFFICES.** Pt. Richmond. Timberwharf Office(s): Overlooking Santa Fe Canal and the KKMI Marina. 1,000 square feet, easily divided. Includes two private restrooms. \$1,000 per month plus utilities. The Cottage: Historic building at KKMI Boatyard. Formerly a two-bedroom cottage, ideal for marine-related office or live/work. Kitchen, bathroom, large living room. \$1,000 per month plus utilities. Contact Paul Kaplan: (510) 235-5564 or [paul@kkmi.com](mailto:paul@kkmi.com).

**LAST OF ITS KIND!** Brickyard Cove Building Lot. Pt. Richmond. \$595,000. The last deepwater lot with both full San Francisco skyline views and protected water, for your dream home and dock. Some pilings in place, plans available. Last chance! (510) 367-0500 or [jadawallis@hotmail.com](mailto:jadawallis@hotmail.com).

**VACATION BY THE BAY.** Tiburon condo, 2 bdrms/1 bath. Close to sailing & other Bayside recreation, SF, wine country, beaches, bike path, hiking. Community pool, high-speed wi-fi, washer/dryer. \$595/week or \$350 for 3 nights, + deposit. Available first week of Aug & Oct. Contact Chris. [www.digsville.com/listing\\_photos.asp?id=34](http://www.digsville.com/listing_photos.asp?id=34). (415) 383-8200 ext: 103 or [chris@latitude38.com](mailto:chris@latitude38.com).



## BERTHS & SLIPS

**BERTH - PIER 39, SAN FRANCISCO.** \$6,500. Back on market. Beautifully located with view of Telegraph Hill. 40 x 14 with parking privileges at Pier 39 garage. (602) 999-0016 or sally.woelfel@asu.edu. 3712 E Mitchell Dr., Phoenix, AZ 85018.

**50-FT PRIME SLIP PIER 39, SF.** \$46,000. F-Dock, Slip 11, east side. Protected from wind. Close to gangway, showers and marina office. Covered parking across street with special rates for owners. (559) 355-6572 or scorched@tempest-edge.com.

**BERTH SUBLET 60'.** Alameda/Fortman's. \$350/month. Well secured marina on the Alameda estuary. 50 AMP & 30 AMP power. 60 feet dual fingered, beamy berth. Full services. Available for July. Will consider partial/weekly rentals. Close to supermarket, West Marine, restaurants and yacht clubs. (510) 508-8235 or mmcpshersn@earthlink.net.

**36' BOAT SLIP PIER 39 MARINA.** San Francisco. \$14,950. "B" Dock, Slip #31. Close to showers and marina office. Perfect for weekend boaters. (561) 866-7743 or v.vonbailou@me.com.

## CREW

**EXPERIENCED CIRCUMNAVIGATOR.** Schooner - seeks select crew from Mediterranean to Brazil. Legs are: (1) Corsica-France-Spain-Morocco-Gibraltar (2) Gibraltar-Canaries-Brazilian Islands-Bahia (Salvador) Brazil. Legs are 4-6 weeks, October to December 22. Must participate fully and share expenses. Call Mike Johnson, (505) 466-6326 or email Claire at clairehorn@comcast.net.

## JOB OPPORTUNITIES

**SAILING INSTRUCTORS WANTED.** Sausalito. Award winning sailing school, Club Nautique, is seeking friendly instructors with solid boating and people skills for part-time teaching, specifically in our Sausalito location. We have the newest fleet on the Bay and the most active Coastal Program in the nation. Advance your skills, work with professional staff and have fun on the water. Includes boat use privileges and membership benefits. Licensed captains email or call: schooldirector@clubnautique.net or (800) 343-7245.

## BUSINESS OPPORTUNITIES

**MAKE MONEY WITH YOUR BOAT.** Spinnaker Sailing in Redwood City has openings in our charter fleet for 2 late model sailboats 32-40 ft. Your boat will make money while not being used. <http://spinnakersailing.com>. Call Rich (650) 363-1390 or rich@spinnakersailing.com.

**BEST SAILING BUSINESS IN HAWAII.** Live your dream in the heart of Paradise! Well-established, turn-key money-maker with the best kind of cash flow. Hands-on or absentee ownership ideal for semi-retired sailor/sailorette. Training and low down payment financing available. amexpc@hotmail.com.

**SAILS, SAILS, SAILS, SAILS!** \$12,000. Major Hong Kong sailmaker's California office/territory. A turn key money maker! Low overhead Grand Marina office, killer view! Owner retiring. Will train. Ideal for semi-retired sailor/sailorette! \$12K, easy terms available. A fun job! Email salty1938@yahoo.com.

## Sold My Boat!

"As a result of my Classy Classified in the June issue of *Latitude 38*, our boat sold quickly. Thanks for your help in making the placement of the ad easy, and for your great customer support!"



If you want a proven method to sell your boat, get your ad into the next issue of *Latitude 38* – the deadline is the 18th at 5:00 pm. A 40-word ad is just \$40, and best of all, you can do it online!

[www.latitude38.com](http://www.latitude38.com)

# GOLDEN STATE DIESEL MARINE

PARTS  
YANMAR • UNIVERSAL • WESTERBEKE  
PERKINS • ISUZU • PATHFINDER • ATOMIC 4  
SERVICE  
DIESEL ENGINES

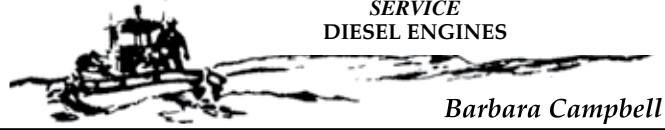

Barbara Campbell

351 EMBARCADERO  
OAKLAND, CA 94606

(510) 465-1093

## "YOUR DESTINATION FOR A FULL SERVICE MARINA"

Clipper Yacht Harbor

800 SLIPS 20-60 FT

- Dry Storage Available
- Fuel Dock
- Salty's Bait & Tackle
- Sport Fishing
- Restaurant
- Launch Ramp
- Pump Out
- Laundry Facility
- Private Restrooms and Showers
- West Marine
- KKMI Boat Yard
- Guest Slips Available

310 Harbor Drive, Sausalito, CA 94965  
(415) 332-3500 ▪ [www.clipperyacht.com](http://www.clipperyacht.com)

## DF DIESEL FUEL FILTERING



Purify Diesel Fuel & Flush Tanks

Process scrubs, polishes, removes algae, dirt, sludge, rust, water, and foreign particles from diesel fuel. Includes internal tank washdown. Save your injectors, costly engine repair and down time.

Since 1989. Fully insured. Your berth or boat yard.

(510) 521-6797 Fax: (510) 521-3309

[www.dieselfuelfilterings.com](http://www.dieselfuelfilterings.com)

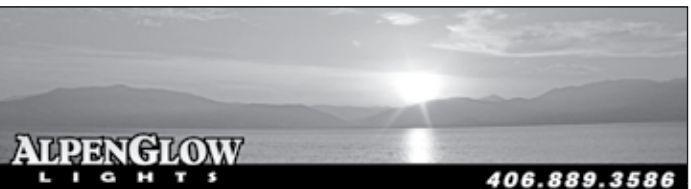

## Hand Crafted, High-Efficiency Area Light LED Swivel Reading Light in Chrome or Titanium Finish

Alpenglow Lights use the latest compact fluorescent and LED technology for unmatched efficiency and light quality. The attractive wood fixture is available in different wood choices. Dual power allows choice of bright light or gentle glow, and two levels of red. Prismatic lens designed for wide-angle illumination. Website provides helpful information on selecting cabin lighting.



Alpenglow Lights, LLC, P. O. Box 415, Eureka, MT 59917  
[alpenglowlights@gmail.com](mailto:alpenglowlights@gmail.com) · [www.alpenglowlights.com](http://www.alpenglowlights.com)

# Latitude 38

we go where the wind blows

## Online

### latitude38.com

The home page for *Latitude 38* for almost 15 years. The site is a pathway to our unique editorial content for sailors all over the globe.



### 'Lectronic Latitude

Published for ten years this thrice-weekly (MWF) online journal of sailing is a magazine appetizer. Brief stories that provide a quick break for deskbound sailors, 'Lectronic Latitude' provides welcome relief and often a preview of more fun and detail coming in the monthly magazine.



### eBooks

The monthly edition of *Latitude 38* is available as a FREE download anywhere in the world. This expands *Latitude's* reach by allowing readers everywhere to read the publication in magazine format with full online connectivity.

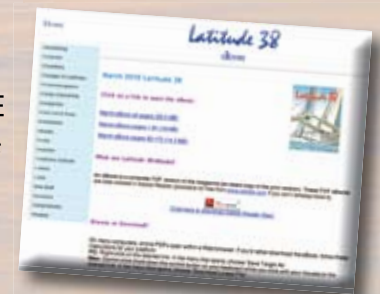

### Boat of the Day

Available to yacht brokers, an exclusive featured boat for sale position on the MWF editions of the online sailing journal 'Lectronic Latitude. Ask your broker about it today!

### Sponsor Links

Featured display advertisers have access to additional links on our online sponsor page. Give a 'click' to support the great advertisers who help bring you *Latitude 38*!

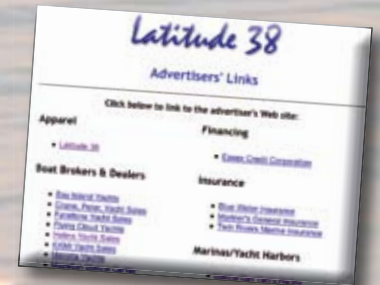

Latitude 38

15 Locust Avenue

Mill Valley

CA 94941

Tel (415) 383-8200

Fax (415) 383-5816

latitude38.com

Online, in print and on the water,  
*Latitude 38* brings you a lively, inspired publication  
connecting the world through the eyes of the west coast sailor.

Invitation to Ballena Bay Yacht Club's

# Island Party

Featuring  
**ERIC STONE**

**Saturday, August 7**

Dinner/Music: \$35/person  
Music only: \$10/person

Dinner reservations required  
**(510) 523-2292**

[www.bbyc.org](http://www.bbyc.org)



## Simply Great Sleep

Transform your mattress with our box-spring system and enjoy many relaxing nights aboard.



**Froli**

phone 888.463.7654  
Nickie Atlantic, LLC  
[www.FroliSleepSystems.com](http://www.FroliSleepSystems.com)

# Vessel Electric

Mobile marine navigation installations and marine electrical work

*Serving all corners of the Bay: North, South, East - and San Francisco!*

- Raymarine® warranty dealer and certified installer
- NMEA-certified Marine Electronics Installer
- Insured

**Raymarine** Milltech Marine AIS **NAVPOD**

**Brian Theobald • (415) 424-2204**  
[vesselelectric@yahoo.com](mailto:vesselelectric@yahoo.com)

## Marine Diesel Specialists

### AT YOUR SLIP!



30 years experience • Universal/Westerbeke dealers  
Repairs/Tune-ups all models • Engine Surveys, Instruction

**BAY MARINE DIESEL** **510-435-8870**

[baymarinediesel@comcast.net](mailto:baymarinediesel@comcast.net)

## ADVERTISERS' INDEX

247Sailing.net/	Blue Pelican .....	168	Dorgan Yachts .....	176	Hogin Sails .....	64	Marina de la Paz .....	164
SV: Simpatica .....	Blue Water Yacht Insurance.....	40	Downwind Marine.....	152	Hood Sails.....	23	Marina El Cid .....	170
AB Marine.....	Bluewater Network.....	174	Doyle Sails .....	33	Hotel Coral & Marina.....	154	Marina Puesta Del Sol .....	156
ABC Diving.....	Boat US.....	109	e Marine Systems .....	166	Hotwire Enterprises.....	168	Marina Riviera Nayarit.....	50
Adventure Cat Charters .....	Boat Yard at Grand Marina,		Easom Rigging.....	132	Hydrovane.....	62	Marina Village.....	19
Afterguard Sailing Academy.....	The .....	13	Emery Cove Yacht Harbor.....	59	'Ingeve': Ingrid 36 ketch.....	176	Marine Engine Company.....	166
Almar Marinas.....	Bob Craven Yacht Sales .....	175	Emeryville Marina.....	153	Interlux Yacht Finishes.....	37	Marine Lube .....	168
Alpenglow Marine Lights .....	Bottom Siders.....	168	Equipment Parts Sales.....	164	Key West Race Week.....	43	Marine Outboard Company.....	56
Aqua Marine .....	Brisbane Marina .....	123	Essex Credit Corp.....	18	Kissinger Canvas.....	108		
Bacon Sails & Marine	BVI Yacht Charters.....	138	Farallone Yacht Sales.....	10,11	KKMI - Brokerage.....	177		
Supplies .....	City Yachts.....	9	Flying Cloud Yachts .....	176	KKMI - Full Service			
Baja Ha-Ha Sponsors .....	Clipper Yacht Harbor.....	171	Fortman Marina.....	20	Boatyard .....	180		
Ballena Bay Yacht Club.....	Coast Marine.....	141	Garhauer Marine.....	31	Landing School, The .....	109		
Bay Area Boat Works .....	Conch Charters.....	138	Gentry's Kona Marina .....	159	Lee Sails .....	164		
Bay Island Yachts .....	Cover Craft.....	61	Gianola Canvas Products.....	158	Leukemia Cup.....	131		
Bay Marine Boatworks.....	Coyote Point Marina.....	27	Golden State Diesel		Lewmar Marine.....	36		
Bay Marine Diesel .....	Cruising Expeditions.....	140	Marine .....	171	Lifeline Batteries .....	114		
Bay View Boat Club.....	Cruising Yachts .....	7	Grand Marina .....	2	List Marine Enterprises.....	91		
Bayside Canvas .....	CYOA Yacht Charters.....	136	Hanse North America.....	67	Loch Lomond Marina.....	115		
Bellhaven Yacht Sales &	Defender Industries.....	62	Hansen Rigging .....	119	Lowrie Yacht Harbor.....	71		
Charters .....	Dept. of Boating &		Helms Yacht & Ship Brokers ...	175	Lunasea Lighting .....	63		
Berkeley Marina.....	Waterways .....	35	Helmut's Marine Service.....	164	Mack Sails.....	67		
Berkeley Marine Center .....	DeWitt Studio .....	159	Heritage Marine Insurance.....	115	Makela Boatworks.....	170		
Beta Marine Engines.....	Diesel Fuel Filtering .....	171	Hobie Cat.....	71	Marina Bay Yacht Harbor .....	47		

(Continued on next page)



## 2003 TARTAN 4400: TARTINI TIME



**\$429,000**

- Hull #1 of of Tartan's newest Deck Salon
- Espar central heat • New bottom paint
- Electric winches • Cruising spinnaker
- Kato davits with Caribe inflatable • Bow thruster
- Only 180 hours on diesel engine • New folding prop

*Boat is loaded with options and in new condition.  
Call for details and other photos.*

**(530) 318-0730**

amjohn@sbcglobal.net

See actual boat at [www.youtube.com/watch?v=ckZHxXEAMec](http://www.youtube.com/watch?v=ckZHxXEAMec)

*Will coop with brokers.*

## Donate your Boat

**Cars, Trucks, RVs, & Real Estate**

*We handle all DMV & Smog  
Running or Not*

**Tax Deduction**

**BLUEWATER NETWORK** | **800-324-7432**

*"Proceeds help Bluewater Network reduce greenhouse gases, clean up our air and water, and protect marine mammals and wildlife."*

## ATLANTIC 57 CATAMARAN™



THE ORIGINAL PILOTHOUSE CATAMARAN

- o Designed for easy shorthanded cruising
- o Spectacular windward performance
- o Cored epoxy/glass/carbon construction

**CHRIS WHITE DESIGNS**

TEL: 508-636-6111

[www.chriswhitedesigns.com](http://www.chriswhitedesigns.com)

## ADVERTISERS' INDEX – continued from previous page

Marine Service Corps.....162	North Sails.....166	Sail Hasty Heart.....139	Tartan 4400: 'Tartini Time' ....174	Warmington Homes.....14
Marine Servicerter.....55	North Sails - San Francisco.....41	Sail the Bay.....140	The Cruise Director.....137	Weatherguy.com.....162
Mariner's General	Opequimar Marine Center.....152	Sail Warehouse, The.....159	The Dinghy Doctor.....65	Wedlock, Ramsay & Whiting
Insurance.....90	Orange Coast College.....51	Sailrite Kits.....34	TMM Yacht Charters.....136	Marine Surveyors.....170
Maritime Institute.....159	Outboard Motor Shop.....54	Sal's Inflatable Services.....103	Tradewinds Sailing School.....63	West Marine.....22,24,26,28
Marotta Yachts.....178	Owl Harbor.....69	San Francisco Boat Works.....155	Trident Funding.....4	West Marine - Rigging.....67
Mathiesen Marine.....166	Oyster Cove Marina.....30	San Juan Sailing.....139	UK-Halsey Sails.....58	Westpoint Harbor.....44,45
Mazatlan Marine Center/ La Paz Yachts.....8	Oyster Point Marina.....158	Scanmar International.....57	Ullman Sails.....54	Westwind Precision Details.....39
McDermot Costa Insurance.....69	Pacific Crest Canvas.....55	Schaefer Marine.....63	Vallejo Marina.....141	Whale Point Marine
McGinnis Insurance.....55	Pacific Rigging.....61	Schoonmaker Point Marina.....157	Ventura Harbor Boatyard.....154	Supply.....32
Mettec, Inc.....66	Pacific Yacht Imports.....6	Seashine.....65	Vessel Electric.....173	White, Chris Designs.....174
Milltech Marine Inc.....60	Pasha Hawaii.....118	Seatech.....159	Voyager Marine.....156	Yachtfinders/Windseekers.....8
Minney's Yacht Surplus.....162	Passage Yachts.....5	Shadetree Fabric Shelter.....59		
Modern Sailing School & Club.....91	Peter Crane Yacht Sales.....175	South Beach Harbor.....38		
Napa Valley Marina.....52	Pineapple Sails.....3	South Beach Riggers.....39		
New Found Metals.....108	Punta Mita Beachfront Condos.....141	South Beach Yacht Club.....133		
Nickle Atlantic/Froli Sleep Systems.....173	Quantum Pacific.....15	Spud Point Marina.....57		
Norpac Yachts.....179	Quickline.....58	Sta-Lok Terminals.....66		
Norstar Boats/Norstar 40.....65	Raiatea Carenage Services.....96	Starbuck Canvas.....57		
North Beach Marine Canvas.....39	Richardson Bay Marina.....91	Svendsen's Boat Works.....21		
North Direct Sails.....103	Rooster Sails.....109	Svendsen's Marine.....48		
	Ryan's Marine.....170	Svendsen's Metal Works.....68		
	Sail California.....16,17	Swedish Marine.....119		
		Tacktick.....119		

*Don't forget to tell 'em Latitude sent you!*



# Peter Crane Yacht Sales

Brokerage without walls

In Santa Barbara - experienced, interested, friendly, low pressure



**Schock design 44 ketch**  
1974 strong cruiser new Yanmar



**Freedom 45**  
1991 carbon fiber rig easy and fast



**Schock New York 36**  
1982 fast, fun, comfortable \$25K



**Lancer 30 built by Willard**  
1977 pocket cruising vet \$15K



**Block Island 42 ketch**  
1945 a bristol classic rich interior \$59K



**Hunter 310**  
1999 modern and well equipped \$50K

details at [www.petercraneyachts.com](http://www.petercraneyachts.com)  
[pc@petercraneyachts.com](mailto:pc@petercraneyachts.com)

**(805) 963-8000**

Santa Barbara Slips Available

# Bob Craven Yacht Sales

Santa Barbara, CA

"Mayan"



## SAIL

59' Alden Schooner '47/'05	\$ 1,000,000	Composite
65' Gamage Schooner '47	\$ 349,000	Wood
47' Mason Yawl '56	\$ 160,000	Wood
36' C&C 110	\$ 162,000	Glass/Epoxy
32' Fuji Ketch '76	\$ 44,900	Fiberglass

## POWER

52' Ocean Alexander '00	\$ 575,000	Fiberglass
42' Californian LRC '77	\$ 129,000	Fiberglass
32' BHM Downeast '94	\$ 112,000	Fiberglass

**(805) 689-9864**

[www.cravensells.com](http://www.cravensells.com)

# M U L T I H U L L S



**SEAWIND 1160** Call us about charter test sail.



**CHRIS WHITE HAMMERHEAD 54**



**PDQ 32 ALTAIR**

Two boats from \$139,000.



**CORSAIR 24 MKII**

\$34,000.



**GEMINI 105M**

\$124,000.



**36' SEAWIND 1000XL, 2001**

Two boats from \$169,000.



**CORSAIR SPRINT 750**

2 starting at \$49,500.



**31' CORSAIR, 1998**

\$105,000.



Dealer for Seawind Catamarans  
and Corsair Trimarans

[www.helmsyacht.com](http://www.helmsyacht.com)  
**(510) 865-2511**



**CORSAIR 28CC, 2005**

\$89,900.

Corsair 28AC, 1998  
\$59,000.



# Flying Cloud Yachts



**Hans Christian**

**GEMINI**

Sail • BROKERS • Power

6400 Marina Drive  
Long Beach, CA 90803

www.yachtworld.com/fcyachts  
flyingcloud@verizon.net

Phone (562) 594-9716  
Fax (562) 594-0710



31' & 36' MARINERS Inquire



SISTERSHIP

36' HUNTER, '05 ~~\$124,900~~ \$119,500



IRWIN 42, '77 \$59,500

## TWO CATALINA 380s TO CHOOSE FROM!



1998  
Real nice!  
\$115,000



2001  
Hard dodger. LOADED!  
\$140,000



43' TASWELL, '89 \$259,000



38' HANS CHRISTIAN, '86 \$149,500



47' GILS CATAMARAN, '02 \$395,000



GEMINI 105Mc, 3 from \$110,000



42' CATALINA, '93 ~~\$118,000~~ \$109,000

APPROX. 100 LISTINGS ON OUR WEB SITE: [www.flyingcloudyachts.com](http://www.flyingcloudyachts.com)

## DORGAN YACHTS



42' BENETEAU CC, 2002  
Well maintained. Many upgrades.  
\$229,990



41' HUNTER 410, 2000  
Solar panels. Well cared for.  
Great value. \$134,500



49' BENETEAU, 2008  
Late model, low hours, one owner.  
Like new. Great value. \$374,000



42' BENETEAU 423s, 2004 & 2005  
Both loaded with options. Ready to  
cruise. Two available from \$199,000.



56' CARVER, 2005  
One owner. New electronics and  
new HDTVs. Reduced to \$649,000.



25' SCHOCK HARBOR, 2008  
Classic beauty!  
\$78,500

(619) 459-1648 • San Diego • [www.dorganyachts.com](http://www.dorganyachts.com)

## INGWE South African Beauty

1960 Wooden  
Ingrid 38 Ketch

Built in South Africa, very strong  
and fast. Has completed two  
Cape Town to Rio races,  
cruised extensively, had a  
baby born on her – lots  
of history. Wood is in  
excellent condition,  
good recent survey.

50 years young –  
and in our family  
for 33 of them –  
*Ingwe* is ready  
for 50 more!

**BEST  
OFFER**

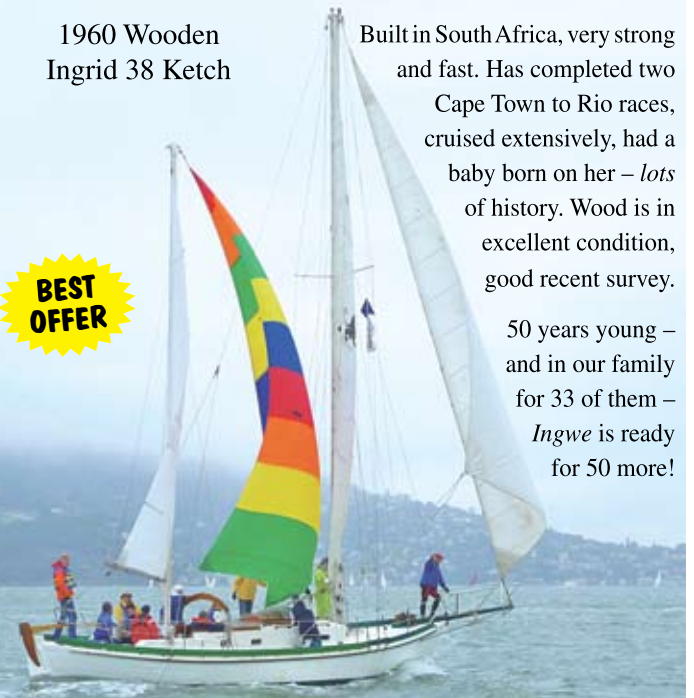

(707) 974-3803 • [jay@adventurecat.com](mailto:jay@adventurecat.com)



**☎(510) 236-6633 • fax: (510) 231-2355**  
**yachtsales@kkmi.com • www.kkmi.com**  
**530 W. Cutting Blvd., Pt. Richmond, CA 94804**

**LIST WITH US!**  
 Ask us about our  
**Maritime Protection  
 Program to find out  
 what a warranty can  
 do for the sale of  
 your yacht!**



**Hinckley Bermuda 40 MkII Yawl CB (1968)**  
 Bill Tripp design B-40 is highly regarded for her classic beauty, superb workmanship and many quality details. New sails, dodger, intelligently updated. Excellent condition.  
 Asking **\$147,000**



**Nelson Marek Custom**  
 A 92-ft aluminum world cruiser. Recently repowered. Immaculate throughout and in perfect condition.  
**\$1,500,000**



**Little Harbor 51 (1996)**  
 Very comfortable Ted Hood designed pilot-house with full stand-up headroom and 360° visibility. Set up for shorthanded sailing and superbly maintained by an experienced owner.  
 Asking **\$619,000**



**Swan 45 (2003)**  
 Race or cruise. *Rancho Deluxe* won her class in the TransPac and was second twice in the Big Boat Series. This boat has all the gear to go cruising and is in perfect condition.  
**\$625,000**



**Swan 40 (1996)**  
 Frers design, exceptionally well maintained, 2-cabin performance cruiser. Awlgrip Flag Blue hull, comprehensive sail inventory, and full in-slip cover.  
 Asking **\$299,000**



**Baltic 42 DP (1984)** Since 1973, Baltic Yachts of Finland have been building fine pedigree yachts with the philosophy that a comfortable, safe, long distance cruising boat should have very good sailing and performance characteristics. Doug Peterson design, superbly maintained, hull #29 of 30. Asking **\$165,000**



**DeVries 86' Motor Vessel (1949/1999)**  
 'Elegant', 'Exceptional', 'Exquisite' are just a few words that easily characterize this vessel. *MV Far Niente* clearly defines the term 'Classic Motor Yacht'.  
 Asking **\$1,950,000**



**Jarvis Newman 36 (1978)**  
 Classic flybridge 'lobster boat' of Maine build quality. Single engine (160 hours), queen V-berth with enclosed head. Excellent condition, well maintained and lightly used.  
 Asking **\$129,000**



**Santa Cruz 52 (1993)**  
 Beautiful, fast cruiser, set up for short-handed sailing. Maintained to very high standards, the hull has been repainted in stunning red with new bottom paint.  
 Asking **\$490,000**



# Marotta Yachts of Sausalito

Brokers of Fine Sail and Motor Yachts

415-331-6200 • info@marottayachts.com • www.marottayachts.com

See at: [www.marottayachts.com](http://www.marottayachts.com)

**NEW LISTING**



**58' HATTERAS MOTORYACHT, 1973** Once the flagship of the Hatteras fleet, the 58 is a Jack Hargrave-designed classic with lines as attractive today as 30 years ago. Three staterooms, galley down, enclosed aft deck, extensively updated. **\$198,000/offers**

See at: [www.marottayachts.com](http://www.marottayachts.com)



**41' SCEPTRE RAISED CABINTOP CUTTER, 1985** Professionally maintained local boat shows VERY nicely inside and out. Leisure Furl in-boom system w/Hood main, Harken roller furler and 105% Hood jib, updated electronics, more. **\$195,000**

See at: [www.marottayachts.com](http://www.marottayachts.com)



**40' BENEteau FIRST 40.7, 2003** The First 40.7 combines the excitement of a sleek racer with all the comforts of a luxurious cruiser. This one is a well-equipped beauty that shows new inside and out. She's the deep version (preferable for the Bay). **\$179,000**

See at: [www.marottayachts.com](http://www.marottayachts.com)



**43' HANS CHRISTIAN, 1978** Classic offered for sale by original owner. New teak decks (this was a \$40,000 job alone!), Awlgrippd hull, updated interior, optional larger diesel and Telstar performance keel. **\$169,000**

See at: [www.marottayachts.com](http://www.marottayachts.com)



**38' HANS CHRISTIANs, 1984 & 1979** Two Hans Christians. Both in nice shape with the '84 in particular extensively updated. Motivated owners encouraging offers; full specs and many photos online. **\$124,000 & \$94,000** respectively.

See at: [www.marottayachts.com](http://www.marottayachts.com)



**37' HUNTER 376, 1999** Very spacious, light and airy, this vessel shows as new; must see to appreciate. Out-of-country owners motivated; offers encouraged. Sausalito Yacht Harbor slip can be arranged. **\$97,000**

See at: [www.marottayachts.com](http://www.marottayachts.com)



**48' C&C LANDFALL CUTTER, 1980** Landfall is C&C's first large boat w/emphasis on cruising. This one is a spacious 3-cabin, 2-head cutter that's VERY competitively priced and lying in a transferable Sausalito slip. Motivated owner is encouraging offers. **\$89,000**

See at: [www.marottayachts.com](http://www.marottayachts.com)



**32' CATALINA 320, 1998** Very clean (down below shows as new) and well fit out (charplotter, AP, heat/AC, dodger, bimini, etc.) deep draft model that's competitively priced and lying in a transferable Sausalito slip – a nice turn key package! **\$79,000**

See at: [www.marottayachts.com](http://www.marottayachts.com)



**41' MORGAN OUT ISLAND, 1979** Center cockpit ketch. Never cruised and fresh water kept, she shows much newer than actual age. Note all new stainless steel ports. **\$64,000**

See at: [www.marottayachts.com](http://www.marottayachts.com)



**44' BREWER KETCH, 1985** Tried and true design is incorporated in this bulletproof center cockpit cruising ketch built in the Philippines. Lightly equipped but in good shape overall and VERY competitively priced. (Originally on market at \$90k.) **\$59,000**

See at: [www.marottayachts.com](http://www.marottayachts.com)



**40' CHALLENGER KETCH, 1973** Recently Awlgrippd in beautiful Flag Blue, incredibly spacious below with 6'5" headroom. **\$52,500**

See at: [www.marottayachts.com](http://www.marottayachts.com)



**36' CATALINA, 1985** With almost 2,000 hulls launched, this is one of the most popular 36-ft sailboats ever built. Diesel, dodger, roller furler, new main and rigging and a bristol interior, she shows well. Transferable Sausalito Yacht Harbor slip. **\$49,900**

See at: [www.marottayachts.com](http://www.marottayachts.com)



**30' NONSUCH ULTRA, 1987** Professionally maintained, the interior is flawless and the exterior comes close. Note the transferable Sausalito Yacht Harbor slip with great view. **\$49,700**

See at: [www.marottayachts.com](http://www.marottayachts.com)



**38' MORGAN, 1981** Morgans are well known for quality construction and seaworthiness; high D/L ratio of 265 and long fin keel provide a comfortable ride in the Bay's boisterous conditions. Very clean in and out, with recent, dark blue Awlgrip. **\$49,500**

See at: [www.marottayachts.com](http://www.marottayachts.com)



**31' HUNTER 310, 1999** Vessel in GREAT shape inside and out with \$15k+ spent on upgrades, including new mainsail w/Dutchman flaking and Harken Battcars, Raymarine 4000 AP, Garmin 492 GPS/chartplotter, more! Owner motivated, make offers. **\$39,500**

at 100 BAY STREET • SAUSALITO • CALIFORNIA 94965 since 1946

# NORPAC YACHTS

1150 Brickyard Cove Rd., B9, Pt. Richmond, CA 94801  
(510) 232-7200 • FAX (510) 232-7202  
email: info@norpacyachts.com

**WE HAVE MORE BUYERS THAN BOATS!**  
**NOW** is the time for NORPAC to help **SELL YOURS**

FOR MORE  
SEE OUR  
**norpacyachts.com**  
WEBSITE



**133' CAR FERRY** Conversion: Office/Studio. Ultra spacious. Fully operational. Set up for very comfortable living and working. Ice Class, built in Norway. Fine condition. Absolutely unique and VERY cool. Rare opportunity. **\$375,000**



**40' X-YACHTS X-119 SLOOP.** Famous Danish builder, racer-cruiser one design by Neils Jeppesen. Loaded with gear, radar, new Volvo Penta diesel in 2000 and MORE! Proven ocean winner in Melbourne-Osaka Race. Asking **\$109,000**



**CALYPSEAUX** is a beautiful **39' BENETEAU 393** Slip. Light use; presents as near-new. Dsl, dodger, 2 private stms, 2 heads w/showers, furling, self-tailers, new genny, main, Pryde 95 & 150 jibs, wheel/pedestal, pulpits, inverter, full galley mid-ship, conv't settee/ship's table, ++. **\$158,950**



**NORSEMAN 447** Cutter design by Perry. 44'7" + center cockpit, dsl, watermaker, genset, solar, radar, wheel, aft S/R w/double, 2 heads, AP, furling, self-tending, dodger, bimini & MORE! Asking **\$229,950**



**41' CT-41.** Exquisite example of this revered Garden design w/many custom features. Fiberglass, big dsl, teak deck, cabin heat & fireplace, tiled shower & head, gorgeous interior, alum. spars, full galley, refrigeration & much MORE! MUST SEE... Asking **\$78,950**



Established and unique SF Bay charter business featuring exotic dancers (girls and/or guys for ladies and/or gentlemen), liquor service, comfortable and spacious charter yacht w/tasteful traditional styling/decor. COI for 49 passengers. Turnkey operation; owner retiring. Asking **\$295,000/pos. seller financing.**



**36' ISLANDER** Slip. Well respected and outstandingly popular Alan Gurney design. Wheel steering, dsl, full dbl lineflines w/pulpits, modified fin w/skeg-hung rudder, self-tailers, rigged for short-handed sailing, furling, well laid out and comfortable down below. New trans, dodger and MORE! Asking **\$44,950**



**38' GRAND BAHAMA** flybridge express cruiser. Exceptionally clean, twin dsl, 2 helms, galley, enclosed head w/shower, more! A great value at **\$39,500** Ask



**36' STEEL HARTOG KETCH.** Robust bluewater cruising doubled-ender, 1985. Low hours diesel, radar genset, air conditioning, watermaker, RIB and outboard, O/S liferaft, vane, wheel, pulpits, 2x course lifelines and MORE! GREAT BARGAIN on a go anywhere cruiser! Asking **\$49,950**



**38' MORGAN** Slip. Yanmar dsl, roller furling, 2 spinnakers & big inventory. Self-tailers, radar, GPS/plot ++. Solar, invert, full galley. Cruise ready. Dink and outboard. Lots of gear and VERY NICE. Asking **\$44,950**

## Visit us at BEAUTIFUL & FRIENDLY Brickyard Cove Marina

- SAIL**
- 100' MEGA SLOOP Custom Offshore Performance Cruiser. Comfort & luxury, spacious, sleeps 17, loaded and near new. GREAT CHARTER POTENTIAL!!!! Asking 975,000
  - 58' ALDEN Boothbay Ketch. Center PH cockpit, aft S/R, dsl, heavy glass, world cruiser. AWESOME! Asking 268,950
  - 38' INGRID Ketch by Atkins. Great extra STOUT BLUE WATER CRUISER. Glass double-ender, refit & upgraded, vane, diesel, furling, RADAR & MORE! Asking 51,950
  - 38' CLASSIC English Ketch by Reg Freeman. Breathtaking beauty. **Reduced by 25,000!** Asking 99,950
  - 38' HERRESHOFF CAT Ketch. 1985. Glass, diesel, easy bluewater sailing ..... 54,950
  - 37' HUNTER CHERIBINI Ctr. Dsl, dodger, cruise equipped, Mex. vet. NICE!... Asking 34,900
  - 36' COLUMBIA. Clean and nice. Yanmar diesel, shower, wheel, dodger and more! Very reliable and FUN! Asking 19,950
  - 33+ ROYAL HUISMAN ALUMINUM Cutter by Alan Gurney: World class builder and designer. Yanmar diesel, new standing rig, nav station, liferaft & MORE! Asking 38,500
  - 33' PEARSON VANGUARD Sloop. 1/8. Fine Rhodes design. Extra nice and great value ..... Asking 19,995
  - 32' GULF P/H by Wm. Garden. Diesel, F/G and MORE ..... Asking 13,950
  - 32' ARIES Sloop. Double-ender by Tom Gilmer, F/G, dsl, bluewater cruiser... Asking 22,950
  - 31' CHINESE Junk. Classic lug rig. Charming and beautiful with possible Monterey mooring ..... Asking 23,950
  - 30' STEEL Slocum's Spray replica by Roberts. Dsl, new, unfinished project.. 14,900/Offeres
  - 30' TRIMARAN by Augnaught. Folding, trailer-able pocket cruiser. REDUCED. Asking 29,500
  - 24' MELGES class racer with trailer and outboard. Fast and fair ..... Asking 17,950
- POWER**
- 130' CAMCRAFT Passenger Ship. Certified for 33 passengers overnight. Booked for the season. Virtual turnkey: Money and opportunity, working PNW ..... 2,200,000
  - 100' Steel HIGH ENDURANCE ADVENTURE/CHARTER SHIP in Panama. Turnkey operation. A great opportunity! MOTIVATED! ..... Asking 1,500,000
  - 62' ELCO 1926 CLASSIC MOTOR YACHT. Twin dsl, gorgeous, elegant, comfortable. GREAT LIVEBOARD CRUISER. Must see! Offers encouraged! ..... 148,950
- 56' HOLIDAY MANSION Cruising Catamaran HOUSEBOAT. High-end custom interior, twins & MORE! **Seller Motivated...** 49,950/offers
- 50' TRUMPY TRAWLER, Long range, great layout, 671 N-Series diesel. Needs TLC. A great boat! ..... 44,950/offers
- 48' DUTCH CANAL Barge. Beautiful & comfortable **Sausalito liveaboard.** Steel, diesel. MUST BE SEEN! ..... Asking 219,000
- 45' STEPHENS 1929 classic. Beautiful Gatsby-era motoryacht waiting to transport you back to the days of yachting in the grand style..... Try 75,000
- 43' CLASSIC CALLIS 1923 Custom Express Cruiser. PRICE SLASHED by more than 2/3rds! An incredible BARGAIN! ..... Asking 199,000
- 43' MATTHEWS, '65, diesel. A gem! Loaded and beautiful..... Asking 69,450
- 43' EGG HARBOR Sports Fish Express Cruiser. Awesome twin Cummins diesel beauty with fly bridge and EVERYTHING! Must see ..... Asking 59,950
- 42' GRAND BANKS Twl. Aft cabin, F/B, Onan, twin dsls, radar. Excellent..... 121,000
- 36' SEARAY 360 aft cabin fly bridge express. Twins. Nice & a GREAT VALUE. Asking 34,950
- 34' CLASSIC LAKE UNION DREAMBOAT. We have TWO; a Blanchard and a Rathfon. Starting at a BARGAIN ..... 17,500 Asking
- 28' BAYLINER 2850 FLYBRIDGE SEDAN. New VOLVO/GM 300hp V8, economical & 30+MPH reported. Just completely refurbished & refitted to exceptional condition..... Asking 19,950
- 27' FARALLON Pilothouse, '86. F/G, twin 5L V8s, fast and seaworthy. Just detailed and very nice ..... Asking 51,950
- 22' ALUMINUM PLEASURE TUG. Bufflehead live/cruise. Loaded..... Asking 108,250



**64' SCHOONER (78' LOA).** 1971. Excellent condition. Cummins dsl. Exquisite teak construction, fully fitted out for world cruising. Genset, 10 berths. Beautiful, spacious, seakindly and comfortable. Too much to describe. A fantastic vessel, incredible opportunity, rare find, and fabulous value. MUST SEE! Asking **\$248,950**



**44' STEEL** Canoe-stern cutter by Geo. Buhler/Fred Lagier & Sons. John Deere diesel. Stout steel construction. Awesome bluewater cruiser built to go to sea and stay there. Radar, GPS, etc. Here's your world beater! Asking **\$89,995**



**57' BOWMAN** Ketch. An AWESOME vessel completely equipped for world cruising. TOO MUCH TO LIST; must be seen. Has circumnavigated and also completed the Northwest Passage east to west. Seaworthy, comfortable and roomy, this is your ultimate bluewater cruising yacht. Asking **\$219,950**



**49' CUSTOM** Cold-Molded Ketch by Reliant. Beautiful Hankerson design. Powerful and seaworthy bluewater cruiser in great shape. Built '91. Yanmar diesel, furling, self-tailers, aux. genset, full galley, full electronics and MORE! MUST BE SEEN. Asking **\$119,950**

**CALL (510) 232-7200 OR FREE (877) 444-5087**  
**OR CALL GLENN DIRECT AT (415) 637-1181**  
**FOR INFORMATION & INSPECTION APPOINTMENTS**



**Your Complete Maritime  
Service Centers**

## **PT RICHMOND**

*services including:*

**ENGINE SERVICE  
ELECTRICAL  
RIGGING  
& MORE**

## **SAUSALITO**

*now scheduling for:*

**BOTTOM WORK  
FIBERGLASS  
PAINTING  
WELDING**

*As a non-profit, Call of the Sea  
needs to get the most bang for its  
buck. At KKMI we get great service,  
a great job, at a great price.  
Welcome to the neighborhood!*

*Sail On,  
Captain Alan Olson*

 KKMI Boatyards  
to serve Bay Area  
boaters. For updates  
about progress at the  
Sausalito facility email  
[clippersubscribe@kkmi.com](mailto:clippersubscribe@kkmi.com)