

Latitude 38

Latitude 38

VOLUME 388 October 2009

WE GO WHERE THE WIND BLOWS



OCTOBER 2009

VOLUME 388

Can you spot the empty berth in this picture?



Hint: There isn't one. Visit us and find out why.

GRAND MARINA

- Prime deep water concrete slips in a variety of sizes
- Great Estuary location at the heart of the beautiful Alameda Island
- Complete bathroom and shower facility, heated and tiled
- FREE pump out station open 24/7
- Full Service Marine Center and haul out facility
- Free parking
- Free WiFi on site!
- And much more...

DIRECTORY of GRAND MARINA TENANTS

Bay Island Yachts	12
Blue Pelican Marine.....	174
The Boat Yard at Grand Marina ...	13
Lee Sails.....	178
Marine Lube.....	174
Pacific Crest Canvas.....	61
Pacific Yacht Imports	9
Rooster Sails	168
UK-Halsey Sailmakers.....	126



GRAND MARINA

ANDERSON-ENCINAL

510-865-1200

Leasing Office Open Daily
2099 Grand Street, Alameda, CA 94501
www.grandmarina.com

On the Right Tack

PHOTO: MARIAH'S EYES PHOTOGRAPHY (510) 864-1144



Tackful*

The Santana 22 is a classic example of the durability of good design and construction. First introduced over 40 years ago, the class is still going strong.

This year the class racing schedule consisted of a split season, and *Tackful*, Frank Lawler and Cathy Stieroff's Santana, placed first in the first half and second by one point in the second. *Tackful's* Pineapple mainsail was built in 2000 and Pineapple class jib in 2001. More testament to the durability of good design and construction.

Even when the economy isn't weak, sails that stand the test of time, keeping their shape and strength, are a real value. Stated tactfully, we believe our sails succeed where others' fail. Race or cruise, we are committed to building the best sails possible, carefully designed and expertly constructed.

YOUR DEALER FOR: Musto foul weather gear, Dubarry footwear and Headfoil 2

Sails in need of repair may be dropped off at:
West Marine in Oakland, Alameda, or Richmond;
or Svendsen's in Alameda.

*Powered by Pineapples



PINEAPPLE SAILS

Phone (510) 522-2200

Fax (510) 522-7700

www.pineapplesails.com

2526 Blanding Ave., Alameda, California 94501

For unsurpassed taste
PUSSER'S®
 THE NO. 1 NAVY RUM
 THE ORIGINAL SINCE 1655

Forbes writes, "Pusser's is still made in the same way it was at the time of Trafalgar - in wooden pot-stills as opposed to modern industrial column-stills. This results in the most full-flavored rum available anywhere".



Gold Medals: London 2001, San Francisco 2003 & 2005, International Rum Festival 2008, Rum Masters, London 2009



Like no other rum, PUSSER'S taste is said to have the character of a single malt whiskey or a fine brandy. This comes from its rich content of wooden pot stillled rum that imparts a taste that is uniquely rich and flavorful. And it's natural. No flavoring agents are used. This PUSSER'S taste punches pleasingly through whatever mix you may use. *BUT* it's also great for sipping! Try it neat, or "take the test and taste the difference"! Mix it with your favorite cola and compare it to any other rum and cola and discover the mellow, pleasing character of PUSSER'S.

Liquid History is another name for PUSSER'S RUM. PUSSER'S, the father of navy rum and the original 'grog', was issued to the sailors of Great Britain's Royal Navy for over 300 years from about 1655 to July 31st, 1970.

For those who enjoy tradition, some sea time (when they can get it) and a good drink afterwards, what could be more traditional and taste better than PUSSER'S - the most traditional of all sea drinks.

For more on PUSSER'S and HOW TO FIND IT:
www.pussers.com

IMPORTED BY SHAW-ROSS INT'L IMPORTERS, MIAMI, FL. PUSSER'S RUM 42% ALC/VOL.

CONTENTS

subscriptions	6
calendar	12
letters	20
loose lips	74
sightings	76
rolex big boat series	88
the rebirth of eros	98
idiot's guide to ssb	104
great schooner race	108
ha-ha profiles, pt. II	112
max ebb: a numbers game	124
the racing sheet	128
world of chartering	140
changes in latitudes	148
classy classifieds	166
advertisers' index	177
brokerage	181

Cover:

Rumor has it that BMW Oracle's monster trimaran has sailed at nearly 50 knots for an hour. Here, helmsman James Spithill can be seen 'going commando' about four stories high — he reportedly had the cage that would prevent him from falling to his death removed to show solidarity with his crew.

Photo: Gilles Martin-Raget / BMW ORACLE Racing

Copyright 2009 Latitude 38 Publishing Co., Inc.

Latitude 38 welcomes editorial contributions in the form of stories, anecdotes, photographs—anything but poems, please; we gotta draw the line somewhere. Articles with the best chance at publication must 1) pertain to a West Coast or universal sailing audience, 2) be accompanied by a variety of pertinent, in-focus digital images (preferable) or color or black and white prints with identification of all boats, situations and people therein; and 3) be legible. These days, we prefer to receive both text and photos electronically, but if you send by mail, anything you want back must be accompanied by a self-addressed, stamped envelope. **Submissions not accompanied by an SASE will not be returned.** We also advise that you not send original photographs or negatives unless we specifically request them; copies will work just fine. Notification time varies with our workload, but generally runs four to six weeks. Please don't contact us before then by phone or mail. Send all submissions to editorial@latitude38.com, or mail to Latitude 38 editorial department, 15 Locust Ave., Mill Valley, CA 94941. For more specific information, request writers' guidelines from the above address or see www.latitude38.com/writers.html.

BENETEAU: The Sailor's Choice for Sailing Performance and Beauty

**NEW FIRST 40
AVAILABLE NOW!**



Ask any Beneteau owner what they think of their boat, and they will tell you it's the best one in the line-up. But one thing all Beneteau owners agrees on is how

FUN their boat is to sail and the pure pleasure it gives to them and their **FAMILY.**



NEW 54



A Beneteau's features do not stop at sailing performance. The next best thing to sailing a Beneteau is experiencing its **BEAUTY.**

With more than 100 years of building know-how, and the most modern factories in the world, Beneteau builds incredible **VALUE** into each boat it builds.

Cruisers: 31 34 37 40 43 46 49 54 58 **First Racing:** 36.7 40 45 50

ISLAND PACKET: Premium No-Compromise Yachts for Pleasure and World Cruising



Island Packet owners are legendary in their ownership loyalty, and the **PASSION** they have for their boats.

This passion is exceeded only by Island Packet in its commitment to build a yacht of unquestionable **STRENGTH.**

People who buy Island Packets want the **SECURITY** of knowing that they have a boat that will perform at sea, in the harbor, and in their pocketbooks. Island Packets have the highest resale value in the industry and are an **INVESTMENT** grade yacht. What else defines an Island Packet? Well, its undeniable **COMFORT.**

Estero 37 ~ SP Cruiser ~ 460 ~ 465 ~ 485



ALERION SAILING: The Art of Fun!



Why List With Us?

Results!

With two offices and comprehensive Internet and print advertising, your boat gets exposure. We co-op with brokers all over the U.S. and beyond, so there are no restrictions on its marketability.

If you're serious about selling, come talk to us, seriously.

Why Shop With Us?

Selection!

All our salespeople are committed, involved brokers with years of experience in this industry. They know boats and people who own them and are able to obtain a good variety of used listings that are clean and well priced. It's our business, and we do it well.

SELECT LISTINGS



**Beneteau 57, 2009
Call**



**Island Packet 40, 1998
\$269,000**



**Hunter 450, 1998
\$179,000**



**Pearson 36, 1985
\$69,000**



**Beneteau 373, 2006
\$153,500**

SAIL

Beneteau 49, '07	339,000
Beneteau 473, '04	259,900
Hunter Legend 450, '98 ..	179,000
Beneteau First 45F5, '91	160,000
Beneteau 43, '08	235,000
Catalina 42 MkII, '97	160,000
Cascade 41, '71	59,900
Beneteau First 40.7, '00	124,900
Island Packet 40, '98	269,000
Beneteau 393, '03	139,500
C&C 37+/40, '89	104,000
Beneteau 373, '06	153,500
Island Packet 370, '04	299,000
Pearson 36, '85	69,000
Fantasia 35, '79	74,900
J/109, '03	185,00
Catalina 30, '79	22,500

POWER

Californian 42, '87	119,500
Sea Ray 340, '06	169,500
Carver 32, '90	39,000
Tiara 29, '98	69,900

Check out our blog: www.passageyachts.blogspot.com
See our full product listings at: www.passageyachts.com



**Pt. Richmond
Office**

1220 Brickyard Cove Rd
p: 510-236-2633
f: 510-234-0118

**Two
Locations!**

**Alameda Office
Marina Village**

1070 Marina Village Pkwy
Suite 101
p: 510-864-3000
f: 510-337-0565

FOR THE TIME OF YOUR LIFE

www.passageyachts.blogspot.com ■ www.passageyachts.com

BENETEAU

ISLAND PACKET

ALERION EXPRESS

WAUQUIEZ

BOAT LOANS

from



Trident Funding

*"a fresh
approach
from people
you can trust"*

*In Northern California call
JOAN BURLEIGH
(800) 690-7770*

*In Southern California call
JEFF LONG
MARGE BROOKSHIRE
(888) 883-8634*

*In San Diego call
MIKE LOCKARD
(619) 255-5666*

www.tridentfunding.com

SUBSCRIPTIONS

Please read form carefully before submitting.

We regret that we cannot accept foreign subscriptions.

Check, money order, or credit card information must accompany request.

Please allow 4-6 wks to process changes/additions, plus delivery time.

eBooks email list. Free!



See www.latitude38.com to download the entire magazine for free! Our eBooks are in PDF format, easy to use with Adobe Reader.

Email: _____

Enclosed is \$36 for one year Third Class Postage

(Delivery time 2-3 weeks; Postal Service will not forward third class, so you must make address change with us in writing.)

Enclosed is \$55 for one year First Class Postage (Delivery time 2-3 days; FPO/APO (military), Canada & Mexico subscriptions are first class only)

Third Class Renewal First Class Renewal (current subs. only!)

Gift Subscription Card to read from: _____

Name _____

Address _____

City _____

State _____

Zip _____

Phone: () _____ Email: _____

CREDIT CARD INFORMATION
Min. Charge \$12

MASTERCARD

VISA

AMERICAN EXPRESS

Number: _____ Exp.: _____ csv: _____

INDIVIDUAL ISSUE ORDERS

Current issue = \$6.00 • With classy ad placed = \$5.00

Back Issues = \$7.00 (must indicate exact issue by month or vol. #)

DISTRIBUTION

We have a marine-oriented business/yacht club in California which will distribute copies of *Latitude 38*. (Please fill out your name and address and mail it to the address below. Distribution will be supplied upon approval.)

Please send me further information for distribution outside California

Business Name _____ Type of Business _____

Address _____

City _____ State _____ Zip _____

County _____ Phone Number _____

Latitude 38

"we go where the wind blows"

Publisher/Exec. Editor.....Richard Spindler..... richard@latitude38.comext. 111
Associate Publisher.....John Arndt..... john@latitude38.comext. 108
Managing Editor.....Andy Turpin andy@latitude38.comext. 112
EditorLaDonna Bubak ladonna@latitude38.comext. 109
Racing EditorRob Grant rob@latitude38.comext. 105
Contributing Editors.....John Riise, Paul Kamen
Advertising SalesJohn Arndt..... john@latitude38.comext. 108
Advertising SalesShawn Grassman..... shawn@latitude38.comext. 107
General Manager.....Colleen Levine colleen@latitude38.comext. 102
Production/WebChristine Weaver chris@latitude38.comext. 103
Production/PhotosAnnie Bates-Winship ... annie@latitude38.comext. 106
BookkeepingHelen Nichols..... helen@latitude38.comext. 101
Directions to our officepress 4
Subscriptionspress 1,4
Classifiedclass@latitude38.compress 1,1
Distributiondistribution@latitude38.compress 1,5
Editorialeditorial@latitude38.compress 1,6
Calendarcalendar@latitude38.com
Other emailgeneral@latitude38.com

Please address all correspondence by person or department name

15 Locust Avenue, Mill Valley, CA 94941 • (415) 383-8200 Fax: (415) 383-5816

www.latitude38.com



F A R A L L O N E



Introducing 2010 R29 "Newport Edition"



Ranger 29



Preowned Catalina Yachts

Catalina 470	2006	\$399,900
Catalina 440	2005	\$331,900
Catalina 42	2001	\$185,000
Catalina 42	2005	\$249,000
Catalina 42	2001	\$169,000
Catalina 42	1992	\$119,000
Catalina 400	2001	\$179,000
Catalina 380	1998	\$127,000
Catalina 380	2000	\$129,000
Catalina 380	1999	\$127,000
Catalina 36	1989	\$52,900
Catalina 36	1987	\$54,000
Catalina 36	1990	\$55,900
Catalina 36	2002	\$199,500
Catalina 350	2004	\$139,800
Catalina 320	2001	\$86,000
Catalina 320	2002	\$95,000
Catalina 310	2007	\$115,000
Catalina 280	2004	\$65,500
Catalina 270	1995	\$36,000
Catalina 28	2004	\$65,500

Preowned Sailing Yachts

Hunter 466	2000	\$219,500
Cavalier 45	1985	\$225,000
Morgan 45CC	1992	\$159,000
Jeanneau 43DS	2002	\$235,000
Hunter Passage CC 42	1996	\$144,900
Bavaria 42	2006	\$189,900
Jeanneau 42DS	2005	\$249,000
Fountaine Pajot 42	1995	\$269,000
Hunter 41	2004	\$150,000
Hunter 41	2004	\$150,000
Morgan 38	1979	\$57,500
Freedom Ketch 44	1981	\$97,000
Hunter 36	2004	\$125,000
Jeanneau 36	2008	\$149,000
Wylie 36	1978	\$57,500
Hunter 35.5	1993	\$59,000
Hunter 340	1998	\$79,000
Hunter 310	2000	\$50,900
Irwin 34	1985	\$29,000

Seawind Cat 33	1997	\$139,000
Cheoy Lee 32	1977	\$36,500
Hunter 306	2004	\$59,500
Coarsair 750	2007	\$49,900
Coarsair 31	2001	\$119,000

Preowned Power Yachts

Trojan 37	1998	\$44,900
Trojan II Meter Exp 37	1988	\$49,900
Regal 2860	2004	\$57,000

New Ranger Tugs in Stock

Ranger 29 Tug	2010	\$214,937*
Ranger 25 Tug	2009	\$137,937*
Ranger 21-EC Tug	2009	\$49,937*
Ranger 21-EC Tug	2010	Coming

*Base price.

New Location!

1070 Marina Village Pkwy.
Alameda CA 94501
510 • 523 • 6730

2801 West Coast Hwy
Newport Beach CA 92663
949 • 610 • 7190

2353 Shelter Island Drive
San Diego CA 92106
619 • 523 • 6730

www.faralloneyachts.com

Yachtfinders/Windseakers

in the heart of
San Diego's boating community

2330 Shelter Island Dr. # 207, San Diego, CA 92106

info@yachtfinders.biz

(619) 224-2349

Toll Free (866) 341-6189

Go to
www.yachtfinders.biz
for all our 80+ listings!



58' FARR CC, '87 \$396,900
Imagine has been circumnavigated, impeccably maintained and constantly upgraded by her fastidious owners.



46' BENETEAU OCEANIS 461, '99 \$124,500
Great family boat, perfect for entertaining with a spacious layout and three separate sleeping areas. Ready for Mexico.



44' MASON, '85 \$212,500
Price reduced from \$224,000! The owner may consider financing to assist you in owning this world-class yacht.



44' HANS CHRISTIAN PH, '81 \$249,900
Very well maintained by all three of her owners. West Coast veteran from Glacier Bay to Puerto Vallarta.



43' FARR PERF. CRUISER, '94 \$175,000
Relax and enjoy her creature comforts: take a fresh water shower, sleep in a big bunk and microwave your meals.



42' PASSPORT, '81 \$129,900
Anyone considering offshore passages must take a serious look at this fast, comfortable performance cruiser.



42' PRIVATEER CC, '89 \$59,900
For health reasons, all offers will be seriously considered on this Mexico vet and proven, safe and durable vessel.



40' OLSON, '84 \$85,000
Race J/120s boat for boat. Very competitive race boat and comfortable cruiser. Great performance at all points of sail.



40' BENETEAU OCEANIS 400, '96 \$99,000
Equally comfortable on day sails and harbor hopping up or down the coast. Add some cruising gear and head out.



36' SCHOCK NEW YORK, '82 \$37,500
This classic racer/performance cruiser had an extensive refit. Functional and comfortable layout below keeps crew happy.



32' WESTSAIL, '73 \$54,500
One of the true go-anywhere offshore vessels that have been to every corner of the globe. Seaworthy and ready to go.



30' TOREHOLM, '60 \$45,000
Sweden-built sloop designed by a winner of Olympic sailing medals. An absolute delight to see. Impeccably maintained.

See us at the Annapolis Boat Show



HYDROVANE
SINCE 1968

Survive Your Dream

'Great Atlantic Gear Test'
Always rated #1 or #2!



Polar Circumnavigator
Adrian Flanagan



YACHTING MONTHLY October 2006
100 YEARS OF YACHTING
100
Best bits of gear - ever.
HYDROVANE included twice!

HYDROVANE IS BOTH:

- ★ Self Steering
- ★ Best Emergency Rudder

Official Sponsor



SHOWERS EVERY DAY!

ECH₂O Tec Watermakers

BUILT TO LAST!

604-925-2660
www.hydrovane.com
info@hydrovane.com

THINK

Just say no to boxy dodgers!

BEFORE:
The Box



AFTER:
Beyond the Box



STARBUCK



CANVAS WORKS

67 Liberty Ship Way
Sausalito, CA 94965

415-332-2509

Exclusive West Coast Dealer for Tayana Yachts



TAYANA 54 DECK SALON AT OUR DOCKS



SELECT BROKERAGE

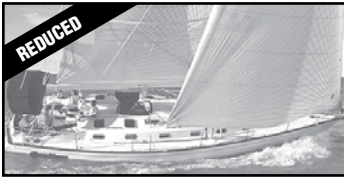

1997 TARTAN 4600

Must see! Custom Kevlar reinforced hull. Beautifully maintained with a huge inventory of equipment and sails. **\$390,000**



2007 TAYANA 46 PILOTHOUSE

Cruise in comfort in any climate with inside steering. With only 12 hours on Yanmar 100 hp dsl, she's virtually new. Over 1,000-mile range under power. **\$369,000**



1984 TAYANA 42 AFT COCKPIT

In great shape and ready to go! Recent upgrades include new Doyle sails, bow thruster, rigging, Awlgrip LPU, AGM batteries and inverter. **\$145,000**



2009 TAYANA 48 DECK SALON

New build at the factory ready to finish with your equipment choices. Two at this price. **\$430,000**



2007 TAYANA 48 DECK SALON

Calmate has a beautiful LPU navy hull and is loaded with gear. Radar arch, davits, Leisurefurl boom, electric winches, full canvas and up to date electronics. **\$525,000**



1973 C&C 48 SLOOP

Great ex-racer refit at the factory with a new interior, wiring, rod rigging and Perkins MT 80. **\$175,000**



1988 FRASER 51 CUTTER

Wingstar is a Canadian-built center cockpit cutter. Great shape and ready to go again. **\$229,000**



2005 TAYANA 48 CC

Just back from Mexico in great shape with everything you need for this year's Baja Ha-Ha. **\$469,000**



1973 BREWER 43 CC KETCH

Custom center cockpit teak ketch properly maintained by a meticulous owner. **\$69,000**



1978 TARTAN 30

Clean, well taken care of example of this timeless S&S design. **\$9,500**



1969 COLUMBIA 43 SLOOP

An oldie but a goodie. *Sunflower* is set for cruising with chartplotter, radar, solar panels, davits and Givens 6-man liferaft. **\$47,500**



1985 HANS CHRISTIAN 38

Proven bluewater cruiser in great shape and ready for her next adventure. **\$109,000**

Pacific Yacht Imports

2051 Grand Street, Alameda, CA 94501

www.pacificyachtimports.net

We're at Grand Marina

Dave Wolfe • Neil Weinberg

Tel (510) 865-2541 Fax (510) 865-2369

tayana@mindspring.com



Ray Watson & Jeannette Sarrasin
Toll free US/CAN: 1 (888) 716-7430
Phone & FAX: 011 52 (669) 913-3165
E-mail: Mazmarine@aol.com



Mike Rickman & Shelly R. Ward
Toll free US/CAN: 1 (877) 245-9689
Phone & FAX: 011 52 (612) 123-1948
E-mail: LaPazYachts@aol.com



www.yachtworld.com/mazmarine



54' DEWAR CUTOM CUTTER KETCH, 1983...\$149,900



45' HUNTER 450 PASSAGE CC, 1998...\$165,000



41' MORGAN OI 415 KETCH, 1979...\$69,900



38' HANS CHRISTIAN TRADITIONAL, 1987 & 1979...INQUIRE



38' ROBERTS OFFSHORE KETCH, 1982...\$55,000



37' TAYANA CUTTER, 1978...\$64,000



37' TAYANA KETCH, 1975...\$59,900



32' DOWNEAST CUTTER, 1976...\$26,900



28' BRISTOL CHANNEL FORERUNNER, 1950...\$39,500

MANY MORE LISTINGS ON OUR WEBSITE AT WWW.MAZMARINE.COM

SAILBOATS ONLY



www.hiddenharbormarina.com

SAUSALITO

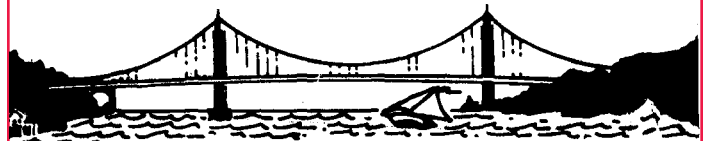

LIST MARINE INC.

- Full service engine shop
- We service all makes
- Dockside facilities
- Mobile service trucks



YANMAR
marine

P.O. BOX 2008 / 69 LIBERTY SHIP WAY • SAUSALITO, CA 94966
Adjacent to Schoonmaker Pt. Marina

415•332•5478

www.listmarine.com

San Francisco's yacht broker since 1969 ~ celebrating our 40th year!

Cityyachts YACHTS AND THE CITY



Cabo Rico 38, '81 \$85,000



Hylas 42, '89 \$165,000



32' Grand Banks, '80 \$89,900



Catalina 34, '94 \$70,000



26' Tollycraft, '79 \$16,500



36' Islander, '75 \$38,500



28' Bayliner 2855, '00 \$44,500



Carver 30, '93 \$59,900



35' Maxum, '02 \$190,000



43' Gran Mariner, '77, \$85,000



35' Niagara, '80 \$58,500



46' Moody, '00 \$399,000



32' Capitol Yachts Gulf, '85
\$42,500



47' Chris Craft Commander, '74
\$199,000



42' Fountaine Pajot Venezia,
'95, \$230,000

10 MARINA BL. • SAN FRANCISCO, CA 94123 • Toll Free: 877-444-5091 • 415-567-8880
FAX (415) 567-6725 • email sales@citysf.com • website <http://yachtworld.com/cityyachts>



PLEASE VISIT OUR FUEL DOCK AT GASHOUSE COVE MARINA • OPEN 7 DAYS A WEEK • 9AM TO 5PM



Bay Island YACHTS

VISIT US ONLINE AT WWW.BAYISLANDYACHTS.COM

BENETEAU OCEANIS 44



1996. Cruise ready. \$139,000

NONSUCH 30 ULTRA



1984, \$65,900

PEARSON 32



1982. Very clean. \$24,500

NONSUCH 33



1989, \$111,900

32' COLUMBIA 9.6



1979, \$13,000

CATALINA 38



1984. Inquire.

CAL 2-27



1975. Inquire.

CATALINA 34



1988, \$43,900

NEWPORT 33



1984, \$29,900

NONSUCH 22



1987. Inquire.

(510) 814-0400

Fax (510) 814-8765

2099 Grand Street, Alameda, CA 94501

www.bayislandyachts.com

yachtsales@bayislandyachts.com

YACHTWORLD.com



CALENDAR

Non-Race

Oct. 3 — 2nd Annual SailFest at Sausalito's Modern Sailing School, 1-5 p.m. Free sailboat rides, live music, food and a boat show. Info, (415) 331-8250.

Oct. 3 — 10th Annual Cheoy Lee Rendezvous. All models welcome! Info, (415) 454-3234 or brentsue@inreach.com.

Oct. 3 — Free Flare Demo at Sausalito YC, 9-11 a.m. Bring your expired flares! Reservations, (415) 332-7400 x114.

Oct. 3 — Howl at the full moon on a Saturday night.

Oct. 4-25 — Free sailing at Pier 40 every Sunday courtesy of BAADS. Info, (415) 281-0212 or www.baads.org.

Oct. 7-28 — Wednesday Yachting Luncheon Series at St. Francis YC, 12-2 p.m., \$13.50. Enjoy lunch and a dynamic speaker every Wednesday. All YCs' members welcome. More info under the 'Events' tab at www.stfyc.com.

Oct. 8 — Single sailors of all skill levels are invited to the Single Sailors Association monthly meeting at Ballena Bay YC, 7:30 p.m. Info, www.singlesailors.org or (510) 233-1064.

Oct. 8 — 'Living on the Water on a Yacht' workshop at Tam High in Mill Valley from 6-9 p.m., \$35. Info, (415) 331-7095 or www.livingonayacht.com. Register at www.marinlearn.com.

Oct. 8 — *Saving the Bay: The Story of San Francisco Bay*, four one-hour episodes exploring the history of the Bay. Episodes 1 & 2 to air Oct. 8 on KQED, 8-10 p.m. Episodes 3 & 4 to air **Oct. 15**. Info, www.kqed.org/savingthebay.

Oct. 8-12 — 40th Annual United States Boat Show, a.k.a. the Annapolis Boat Show. Info, www.usboat.com.

Oct. 8-13 — Hey, sailor, it's Fleet Week, featuring the Blue Angels. Details can be found at www.fleetweek.us.

Oct. 10 — Get ready for the Pacific Cup with the first pre-race seminar at Berkeley YC, 8 a.m.-5 p.m. Required for racers! \$35 pre-reg, \$40 at door. Info, www.pacificcup.org.

Oct. 10 — Martinez Marina Marine Swap Meet, 8 a.m.-2 p.m. The last of the year. Info, (925) 313-0942.

Oct. 10 — Chula Vista Marina's Swap Meet, 7 a.m.-1 p.m. Info, (619) 862-2835 or www.chulavistamarina.com.

Oct. 10 — Janna Cawrse Esarey will read from her hilarious book *Motion of the Ocean* at Book Passage in Corte Madera, 4 p.m. Info, www.byjanna.com.

Oct. 10 — Triton One-Design & Albergs of SF Bay Fall Dinner at Quinn's Lighthouse in Oakland, 7:30 p.m. Info, <http://albergsfbay.memberlodge.com>.

Oct. 10-11 — 17th Annual Northern California Women's Sailing Seminar at Island YC. Info, www.iyc.org/wss.htm.

Oct. 17 — First of three classes by USCGA Flotilla 17 on Yerba Buena: About Boating Safety. Also, How to Read a Nautical Chart (**10/24**), and GPS for Mariners (**11/7**). \$55 each or \$135 for all. Info, FSO-PE@flotilla17.org or (415) 285-1100.

Oct. 17 — SF Maritime Park's Sea Music Concert Series aboard *Balclutha* at Hyde St. Pier, 8-10 p.m. Featuring Robbie O'Connell. \$14 each. Info, (415) 561-6662, ext. 33.

Oct. 17, 24, 31 — Sail aboard SF Maritime National Historic Park's scow schooner *Alma*. Learn the Bay's history on this 3-hour voyage, leaving Hyde St. Pier at 1 p.m. \$35 adult, \$20 kids 6 & up. Info, www.nps.gov/safr.

Oct. 18 — Ha-Ha Welcome to San Diego Party at Downwind Marine, 12-4 p.m. Info, www.baja-haha.com.

Oct. 19 — Electrical Systems seminar for Singlehanded TransPac at KKMI's Boathouse in Pt. Richmond, 7:30-10 p.m. Pac Cup racers welcome! Info, www.sfbaysss.org.

Oct. 19 — Downwind Marine's Cruisers' Seminar Series kicks off with AIS: The Best Collision Avoidance System, by Steven Gloor at Downwind Marine at 7:30 p.m., \$3. More seminars at the same time and location. **10/20**: Sailing Downwind with the Proper Gear & Technique (Bruce Brown); **10/21**:

THE BOAT YARD AT GRAND MARINA

"Where Service Has Meaning"

Interlux
yachtpaint.com

AWLGRIP
POLYURETHANE

**60-TON
TRAVELIFT**



**Congratulations to
Jim Bishop and the crew of
the J/44 Golden Phoenix
2nd Place, IRC C
Rolex Big Boat Series**

FEATURING
TRINIDAD
ANTI-FOULING PAINT BY
PETTIT
marine paint
RATED "SUPERIOR" by
Practical Sailor

*The only yard to
brush on your
bottom paint!*

Dealers for:

MAX-PROP
AUTOMATIC FEATHERING PROPELLERS

GORI
marine

Webasto

PACKLESS SEALING SYSTEM
SHAFT SEAL

LECTRA/SAN

SIDE-POWER
Thruster systems

facnor
PURGING SYSTEMS INC.

AQUAMARINE
FINE REVERSE OSMOSIS EQUIPMENT

IT'S SIMPLE!

Call The Boat Yard at Grand Marina for the Lowest Bottom Prices!

~ COMPARE US WITH THE COMPETITION ~

- Prop and Shaft Work
- Mast & Rigging Repair
- Fiberglass & Blister Repair
- Gelcoat Repair
- Gas & Diesel Engine Service
- LPU Hull & Topside
- Electrical Repair & Installation

CALL FOR A RESERVATION

(510) 521-6100 • Fax (510) 521-3684

Located at Grand Marina • 2021 Alaska Packer Place, Alameda

www.boatyardgm.com

FAST IS FUN!

SC³⁷ Santa Cruz YACHTS



Special Deals on Inventory Boats!
Call for details.

Recent wins reveal SCORCHING SPEED!

2009 Vallejo Race:

Fastest elapsed time, **FIRST** in class

2009 Border Run, Newport to San Diego:

First to finish monohull by one hour!

In the Santa Cruz tradition – a downwind flyer.

Call for a test sail... *and hold on tight!*

Dealers for Santa Cruz Yachts in California

SAI

California

Alameda
(510) 523-8600
info@sailcal.com



Newport Beach
(949) 675-8035
San Diego
(619) 224-6200
jeff@jk3yachts.com

www.jk3yachts.com • www.sailcal.com
www.santacruzayachts.com

CALENDAR

Preparing for the Puddle Jump (Dick Markie); **10/22**: Solar Powered Battery Charging & Systems (Rick Cullen); **10/23**: Cruising Self Sufficiency (Paul Mitchell) & Cruising Woman's Round Table discussion (Susan Mitchell); **11/5**: AIS (Steven Gloor); **11/9**: Pressure Cooking for Cruisers (Steve Ford); **11/10**: Outfitting for Safety at Sea (Bruce Brown); **11/11**: Cruising on 12 Volts (Barry Kessler); **11/12**: Outboard Motor Needs for Cruising in Mexico (Tom Teevin). Info, www.downwindmarine.com.

Oct. 20 — SailMail Marine Communication Seminar by Jim & Sue Corenman and Shea Weston at Pt. Loma Assembly Hall in San Diego, 8:30 a.m.-4 p.m. \$50/person or \$75/couple. Info, Downwind Marine at (619) 224-2733.

Oct. 25 — Cal Sailing Club's free introductory sail at Berkeley Marina, 1-4 p.m. Info, www.cal-sailing.org.

Oct. 25 — Ha-Ha Halloween Costume Party & BBQ in San Diego West Marine parking lot.

Oct. 26 — Baja Ha-Ha 'Sweet Sixteen' Cruisers Rally starts from San Diego!

Oct. 31 — Dress like a pirate on Halloween.

Nov. 1 — Daylight Saving Time ends.

Nov. 8 — Downwind Cruisers' Kick-Off Potluck BBQ at Downwind Marine in San Diego, noon-4 p.m. Info, www.downwindmarine.com.

Jan. 4-Mar. 26 — Full-Time Sailmaking & Rigging Course at Northwest School of Wooden Boat Building in Port Hadlock, WA. Info, www.nwboatschool.org or (360) 385-4948.

Racing

Oct. 2-3 — 46th Annual San Diego to Ensenada Yacht Race. Southwestern YC, www.southwesternyc.org.

Oct. 2-4 — International Masters' Regatta, a J/105 regatta/reunion for seniors. StFYC, www.stfyc.com.

Oct. 3 — South Bay YRA Summer #7. Contact Richard at rjgreenawald@hotmail.com.

Oct. 3 — YRA-WBRA Southampton. Info, www.yra.org.

Oct. 3 — Wallace Cup, a PHRF championship for East Bay clubs. OYC, www.oaklandyachtclub.com.

Oct. 3 — 6th Annual VNA & Hospice Regatta on Monterey Bay. MPYC, www.mpyc.org or (831) 402-3181.

Oct. 3 — Fall Race #2. SSC, www.stocktonsc.org.

Oct. 3 — Kathryn Eavenson Regatta, for all-women crew and skippers. FLYC, www.flyc.org or (916) 635-3911.

Oct. 3-4 — Islander 36 Nationals hosted by GGYC. Info, www.islander36.org/09race.html.

Oct. 4 — El Toro Stampede. RYC, www.eltoroyra.org.

Oct. 4 — Berkeley YC Chowder Series begins and continues every Sunday through March, except on Berkeley Midwinter weekends. BYC, www.berkeleyyc.org.

Oct. 4 — 29th Annual Women Skippers Regatta to benefit youth sailing. SYC, www.syc.org or race@syconline.org.

Oct. 10-11 — SSS Vallejo 1-2, a mellow way to end the shorthanded season. Info, www.sfbaysss.org.

Oct. 14-15 — IOD Team Races. SFYC, www.sfyyc.org.

Oct. 17 — YRA-HDA Yankee Cup & YRA-ODCA Champion of Champions. IYC, www.yra.org.

Oct. 17 — YRA-WBRA Knox. Info, www.yra.org.

Oct. 17 — South Bay Championship. SeqYC, www.seq-uoiayc.org.

Oct. 17 — El Toro Corkscrew Slough Regatta. Sequoia YC, www.eltoroyra.org.

Oct. 17 — Doublehanded Race. TYC, www.tyc.org.

Oct. 17 — Twin Island Race #3. SYC, www.syc.org.

Oct. 18 — Singlehanded Race. TYC, www.tyc.org.

Oct. 17-18 — Jessica Cup, fleet racing for big woodies.

SAIL *California*

YOUR PERFORMANCE YACHT SPECIALISTS

ALAMEDA

1070 Marina Village Pkwy #108
Alameda, CA 94501
(510) 523-8500
FAX (510) 522-0641

SEATTLE

SAIL NORTHWEST
7001 Seaview Ave. NW #140
Seattle, WA 98117
(206) 286-1004

Santa Cruz 52, 2000 *Isis*

The ultimate cruising
boat with shallow
draft.

Asking **\$520,000**



Santa Cruz 52 1999 *Renegade*

Great boat, nicely
equipped and
race ready.

Asking **\$595,000**



J/100, 2005, Reddie Freddie
Now asking **\$112,000**



J/32, 2001, Independence
This is an amazing amount of boat at 32-ft.
Come see her on our sales dock. Asking **\$125,000**



J/109, 2004, Crazy Diamond
Deal of the decade.
Asking **\$185,000**



J/40, 1986, China Cloud
This boat is ready for the Baja Ha-Ha. Are you?
Asking **\$159,000**



J/124, 2007, Fortuna
For the joy of sailing, experience the J/124.
Asking **\$298,000**



Ericson 35 MkIII, Symmetry
Own a classic boat.
Asking **\$49,000**



Olson 40, 1983, Elka
Asking **\$79,000**

77' Andrews, '03**	Reduced!	\$899,000
56' Andrews, '94, <i>Charisma</i>	Pending	\$324,900
52' Santa Cruz, '00, <i>Isis</i>		\$520,000
52' Santa Cruz, '99, <i>Renegade</i>		\$595,000
48' J/145, Hull #9, '03**		\$700,000
48' Kristen Steel Offshore, '01, <i>Trinity</i> **	Reduced!	\$529,000
44' J/44, '90, <i>Phoenix</i>		\$219,000
41' J/124, '07, <i>Fortuna</i>	Reduced!	\$298,000
41' Passport, '90, <i>360</i> **	Reduced!	\$239,000
40' Advance, '85, <i>Caribou</i> **		\$159,500
40' J/120, '01, <i>OuiB5</i>	Reduced!	\$199,000
40' J/40, '86, <i>China Cloud</i>		\$159,000
40' Tripp, '92, <i>Snake Oil</i> **		\$85,900
40' Olson, '83, <i>Elka</i>		\$79,000
39' Carroll Marine CM 1200, '95**		\$82,500
39' Schumacher Custom, '96, <i>Recidivist</i>		\$149,000
38' Sydney, '00, <i>Howl</i>	SOLD	
38' X-Yachts 382, '99, X-TC	SOLD	
36' Jeanneau Sun Odyssey 36.2, '97**		\$89,900
36' J/109, '04, <i>Crazy Diamond</i>	Reduced!	\$185,000

**Back Cove 29,
2005,
Diamond Lil**

She's a beauty with
her new blue hull.

Asking **\$159,000**

36' J/36, '83**	\$57,000
35' J/105, '04, Hull #617, formerly <i>Chili Pepper</i> **	\$127,500
35' J/105, '02, <i>Breezy</i>	\$117,000
35' J/105, '00, Hull #347, <i>Bald Eagle</i>	Reduced! \$109,000
35' J/105, '00, Hull #298, <i>Chilaxn</i>	\$114,000
35' J/105, '99, <i>Life Is Good</i> **	\$83,000
35' J/105, '99, Hull #255, <i>Roadster</i> **	SOLD
35' J/35c, '91, <i>Belle</i> **	\$120,000
35' J/35, '87, <i>Storm Front</i> **	\$55,000
35' 1D35, '01, <i>Tabasco</i>	New Listing \$79,000
35' 1D35, <i>Sweet Sensation</i>	New Listing \$69,000
35' Ericson 35 MkIII, '84, <i>Symmetry</i>	\$49,000

34' J/34, '85, <i>The Zoo</i> **	\$29,900
34' MJM 34z, '08**	\$499,000
34' MJM 34z, '05**	Reduced! \$384,000
34' Classic Hans Pederson Power Yacht, '63**	\$59,000
33' J/100, '06**	\$125,000
33' J/100, Hull #5, '05, <i>Reddie Freddie</i>	Reduced! \$112,000
32' J/32, <i>Independence</i> , '00	\$125,000
30' J/30, '84**	\$34,000
29' J/29, '85, <i>Masthead</i> **	\$28,000
29' MJM 29z, '07**	\$298,000
29' Back Cove, '05, <i>Diamond Lil</i>	Reduced! \$159,000
29' Cobalt 292, '01**	Reduced! \$69,000
28' Alerion Express, '06**	\$110,000
27' NorSea, aft cabin, '91**	SOLD
27' Antrim 27, '98, <i>Luna</i>	Reduced! \$34,900
26' J/80, '01, <i>Lay Down Sally</i>	SOLD
26' Maple Bay, '92**	\$65,000
22' Aquapro Raider 665, '04	Reduced! \$34,900

** Indicates Seattle Boats

SAIL *California*

www.sailcal.com • email: info@sailcal.com

DEALERS FOR THESE FINE YACHTS:

SABRE

Santa Cruz
YACHTS

J
Boats



Cruising Yachts, Inc.

(888) 78-YACHT (619) 681-0633 (949) 650-7245
Alameda San Diego Newport Beach

SUMMER INVENTORY BLOWOUT SALE!

ONCE-IN-A-LIFETIME DEALS ARE GOING FAST!

Proudly Representing



New Sailboats

Brokerage Boats

2010 Jeanneau 57	CALL	2008 Jeanneau 54DS	\$645,000
2009 Jeanneau 54DS	CALL	2005 Stevens 53	\$889,000
2010 Jeanneau 53	CALL	2006 Beneteau 473	\$289,000
2009 Hunter 50 CC	CALL	2002 Hunter 466	\$238,000
2010 Hunter 50CC	CALL	2006 Jeanneau 45	\$329,500
2009 Jeanneau 50DS	CALL	2003 Jeanneau 45.2	\$269,500
2009 Hunter 49	CALL	1997 Beneteau 42.7	\$179,000
2010 Hunter 49	CALL	2000 Hunter 42	\$165,000
2009 Jeanneau 49i	CALL	1986 Cheoy Lee 41	\$89,500
2009 Hunter 45	CALL	2008 Hunter 41 DS	\$228,500
2009 Jeanneau 45DS	CALL	2001 Hunter 410	\$139,950
2008 Jeanneau 45DS	CALL	2001 Catalina 380	\$116,900
2009 Jeanneau 44i	CALL	2004 Hunter 386 LE	\$137,500
2008 Jeanneau 44i Prf.	CALL	2004 Hunter 386 LE	\$136,900
2009 Jeanneau 42DS	CALL	1996 Hunter 375	\$89,900
2009 Hunter 41DS	CALL	1993 Hunter 375	\$71,900
2009 Jeanneau 39DS	CALL	1991 Hunter 37	\$69,950
2009 Jeanneau 39i	CALL	1987 Catalina 36	\$54,500
2008 Jeanneau 39i	\$237,725	1986 Freedom 36	\$69,900
2010 Hunter 39	CALL	2007 Hunter 36	\$149,995
2009 Hunter 38	CALL	2007 Hunter 36	\$149,500
2009 Hunter 36	CALL	2004 Hunter 36	\$103,000
2009 Hunter 33	SOLD!!	1992 Solaris 36	\$89,990
2009 Jeanneau 32	CALL	1996 Bayliner 3485	\$49,995
2009 Jeanneau SunFast	CALL	1997 Catalina 34	\$79,500
2009 Hunter 31	CALL	1999 Hunter 340	\$83,500
2008 Hunter 31	CALL	1999 Hunter 310	\$44,995

THESE 3 NEW HUNTER BOATS MUST GO! PRICED TOO LOW TO PRINT!

'08 Hunter 31 '09 Hunter 33 '09 Hunter 36



www.cruisingyachts.net

CALENDAR

StFYC, www.stfyc.com.

Oct. 17-18 — Joe Logan (Mercuries) & Calvin Paige (Stars) Regattas. StFYC, www.stfyc.com.

Oct. 18 — Lady Skippers Race. PresYC, www.presidio-yachtclub.org.

Oct. 24 — Ruth Gordon Schnapp Regatta, a fundraiser for Susan G. Komen for the Cure that requires a woman to be at the helm. GGYC, www.ggyc.com.

Oct. 24-25 — Great Pumpkin Regatta, a Halloween tradition. RYC, www.richmondyc.org.

Oct. 24-25 — Fall Dinghy & Olympic Classes. StFYC, www.stfyc.com.

Oct. 31 — YRA-OYRA Jr Waterhouse. RYC, www.yra.org.

Oct. 31 — Red Rock Race. TYC, www.tyc.org.

Oct. 31-Nov. 7 — Dry Creek Vineyard Pro-Am Regatta on Virgin Gorda, hosted by Bitter End YC. Info, www.beyc.com.

October, 1979 — It Was Thirty Years Ago from the article "Phantom Gynecologist" by Sue Rowley:

"Hi, how ya'll?" Ted Turner greeted me in his disarming Andy Griffith drawl. His face was smeared with goopy white sunscreen and he looked like a little boy who had just finished a pie eating contest.

We were on our way out to the starting line of the Six Metre eliminations in a big power yacht towing Ted's boat *Ranger* and Tom Blackaller's *St. Francis VII*. Turner was subdued and philosophical that day, wanting to talk more about the crises in America and his dreams for the future than about sailing. Maybe because he wasn't doing so well.

"I don't really like sailing — never did," he claimed. I told him that was difficult to believe, coming from the recent winner of three major ocean events (Annapolis to Newport, Fastnet and SORC).

"My whole life is competition," he continued. "It's an 18-hour day of top-level, back-to-the-wall competition. I'm burned out. I don't have that killer instinct anymore. For a grown man to be screwing around with sailing boats when our nation faces the greatest crises in history . . . we oughta be working."

"Would you like it better if you were winning?" I asked.

"I'd like it somewhat better, but it wouldn't make that much difference. I've won at so many things in my life that it's disgusting! I've literally had the Midas touch. I have a beautiful wife that I love to pieces; I've got five healthy children; I'm worth over a hundred million dollars; I own baseball, basketball, and soccer teams; I have an eight-square-mile plantation with a mansion like Tara; I just bought a 1,200-acre island and am going to put a little beach house on it; I have a 500-acre farm near Atlanta; I own two private TV networks; I have three or four gorgeous girlfriends; I have everything and I'm only 40 years old. I couldn't list anything more that I want. Everywhere I go, people love me."

"Is that what happiness is for you?"

"No, what I want to do is set an example for common sense and dignity and brotherhood and humanity," he said with touching sincerity, and I began to think that Ted Turner has been misrepresented a bit.

He altered my preconceived image of him as the Muhammed Ali of sailing. I found him to be articulate instead of "mouthy," considerate as opposed to "arrogant," independent rather than "opinionated." He has a style all his own, to be sure, but it is definitely a likeable one.

Perhaps he's mellowing. I hope not too much. Now he's off to play with 12 Metres and, hopefully, to defend the America's Cup. Will he really give up sailing? I wouldn't bet on it.

Nov. 1 — Jack & Jill +1, the woman-skipped triplehanded

Not Just Great Sails, But **WORLD CLASS SAILMAKERS!**



With over 40 years combined experience, the sailing specialists at **QUANTUM PACIFIC** offer a vast array of services.

- **SAIL REPAIR** - From simple tears to extreme re-construction.
- **RE-CUTS** - Making your old sail work again.
- **CONVERSIONS** - UV Covers, Dutchman, Strong Tack and more.
- **SAIL WASHING AND REJUVENATION**
- **REMOVAL, INSTALLATION, PICK-UP & DROP-OFF SERVICE AVAILABLE**
- **SAME DAY OR OVERNIGHT REPAIRS AVAILABLE**
- **PROBLEM SOLVING**
- **MUCH MORE!**

Contact us today at 510-234-4334 to learn more about how our services can help, so that you don't miss a single day of sailing.



QUANTUM PACIFIC

1230 Brickyard Cove Rd | Point Richmond, CA
510-234-4334

dteakell@quantumsails.com

CRUISERS!

Head for Downwind Marine!

CRUISER SEMINARS – \$3/person
7:30pm at Downwind Marine



- Mon 10/19 **AIS: The Best Collision Avoidance System** – Steven Gloor, Veteran Cruiser
- Tues 10/20 **Sailing Downwind with the Proper Gear and Technique** – Bruce Brown, Forespar & Johnson Marine
- Wed 10/21 **Preparing for the Puddle Jump/Ocean Passage** – Dick Markie, Dockmaster, Paradise Village Marina, Puerto Vallarta
- Thurs 10/22 **Solar Powered Battery Charging and Battery Systems** – Rick Cullen, President, Blue Sky Energy Inc.
- Fri 10/23 **Cruising Self-Sufficiency** – Paul Mitchell, Circumnavigator
Cruising Women's Round Table Discussion – Susan Mitchell, Circumnavigator
- Tues 10/27 **Cruising Wisdom: Planning Provisions and Storage** – Rod and LeNan Thompson, Veteran Cruisers
- Thurs 10/29 To Be Announced
- Tues 11/3 To Be Announced
- Thurs 11/5 **AIS: The Best Collision Avoidance System** – Steven Gloor, Veteran Cruiser
- Mon 11/9 **Under Pressure! Pressure Cooking for Cruisers** – Captain Steve Ford
- Tues 11/10 **Offshore Safety: Gear You Need and How to Use It** – Bruce Brown, Switlik & Survival Technologies
- Wed 11/11 **Cruising on 12 Volt Batteries, Alternators, Invertors: Tips and Troubleshooting** – Barry Kessler, Xantrex & CEO, Altra Regulators
- Thurs 11/12 To Be Announced
- Fri 11/13 **Outboard Motor Needs for Cruising in Mexico** – Tom Teevin, Aquarius Yacht Services

SPECIAL EVENTS

- Tues 10/20 **Sailmail Marine Communication Seminar**
8:30am-4pm, Point Loma Assembly Hall, 3035 Talbot Street
Intensive training on Internet email service for cruisers with Jim & Sue Corenman and Shea Weston, \$50/person or \$75/couple – includes lunch!
Visit www.sailmail.com/seminars to reserve space.
- Sun 11/8 **Downwind Cruisers' Kick-Off Potluck BBQ**
12-4pm at Downwind Marine. Fun for all!
We bring sodas, burgers & hot dogs.
Cruisers bring salad, side dish or dessert to share.
Meet other cruisers (families, friends and singlehanders).
- 11/9-14 **Downwind Cruisers Week** at Downwind Marine.
THIS WEEK ONLY! During store hours: 8-5 Mon-Fri, 8:30-5 Sat.
Daily buddy boat meetings with coffee and donuts – 10am.
Valuable product info provided by Manufacturers Reps.
See Rep schedule posted at store and Sunday at BBQ.
Discount Prices & Special Deals on manufacturers' selected items.

www.downwindmarine.com

San Diego Marine Exchange



THE CRUISER'S CHANDLERY

2804 Cañon Street
San Diego, CA 92106
Phone: (619) 224-2733
Toll-Free: (866) 289-0242
Fax: (619) 224-7683
info@downwindmarine.com

CRUISERS' NET, Ch. 68, from 8:30 am weekdays: **WHX369**

CALENDAR

race on the Estuary. IYC, www.iyc.org.

Nov. 7-8 — Perry Cup for Mercs. MPYC, www.mpyc.org.

Nov. 17 — The Big Sail: Stanford vs. Cal in J/105s. More fun than football! StFYC, www.stfyc.com.

Remaining Beer Can Regattas

BALLENA BAY YC — Friday Night Grillers: 10/2, 10/16, 10/30. Info, (510) 523-2292 or race@bbyc.org.

CAL SAILING CLUB — Year-round Sunday morning dinghy races, intraclub only, typically in Laser Bahias and JY15s. Email Gary and Alistair at racing_chair@cal-sailing.org.

COYOTE POINT YC — Every Wednesday night through 10/28. Torin Knorr, (650) 863-2570 or regatta@cpyc.com.

LAKE TAHOE WINDJAMMERS YC — Every Wednesday night through 10/14. Mike Robinson, (530) 713-9080.

SANTA CRUZ YC — Wet Wednesdays, every Wednesday night during Daylight Saving Time. Larry Weaver, (831) 423-8111 or lweaver@cruzio.com.

SEQUOIA YC — Every Wednesday night through 10/7. Rich Butts, (650) 576-3990 or rcbutts@pacbell.net.

Please send your calendar items by the 10th of the month to calendar@latitude38.com. If you're totally old-school, mail them to *Latitude 38* (Attn: Calendar), 15 Locust Avenue, Mill Valley, CA, 94941 or fax them to us at (415) 383-5816. But please, no phone-ins! Calendar listings are for marine-related events that either are free or don't cost much to attend. The Calendar is not meant to support commercial enterprises.

October Weekend Tides

date/day	time/ht. LOW	time/ht. HIGH	time/ht. LOW	time/ht. HIGH
10/03Sat	0510/1.2	1138/5.7	1743/0.7	
10/04Sun	0013/5.1	0540/1.5	1204/5.8	1818/0.3
10/10Sat	0616/4.3	1020/3.4	1624/5.7	2335/-0.1
10/11Sun	0724/4.5	1152/3.3	1740/5.5	
10/17Sat	0450/1.2	1121/6.3	1737/-0.3	
10/18Sun	0020/5.2	0530/1.7	1153/6.4	1820/-0.6
10/24Sat	0614/4.4	1041/3.5	1601/5.0	2313/0.5
10/25Sun	0712/4.4	1204/3.3	1707/4.7	
10/31Sat	0351/1.6	1018/5.8	1645/0.3	2323/4.7

October Weekend Currents

date/day	slack	max	slack	max
10/03Sat	0122	0404/3.4E	0738	1029/3.1F
	1327	1622/4.0E	2003	2258/3.4F
10/04Sun	0207	0443/3.3E	0808	1059/3.0F
	1355	1659/4.4E	2040	2337/3.5F
10/10Sat	0049	0354/3.1F	0735	0934/1.6E
	1230	1532/1.8F	1808	2149/4.2E
10/11Sun	0156	0503/3.0F	0838	1040/1.7E
	1358	1644/1.8F	1925	2255/4.1E
10/17Sat	0111	0351/3.5E	0716	1008/3.5F
	1301	1607/4.8E	1952	2255/4.2F
10/18Sun	0205	0437/3.2E	0757	1047/3.3F
	1338	1648/5.0E	2038	2342/4.1F
10/24Sat	0045	0353/2.7F	0721	0918/1.4E
	1249	1521/1.4F	1759	2126/3.4E
10/25Sun	0143	0454/2.5F	0816	1018/1.3E
	1359	1627/1.3F	1905	2223/3.1E
10/31Sat	0016	0248/2.8E	0616	0909/2.8F
	1205	1508/4.1E	1859	2155/3.3F
11/01Sun	0107	0232/2.7E	0552	0844/2.8F
	1136	1447/4.6E	1838	2137/3.6F

Lighted Yacht Parade

THIS YEAR'S THEME
**Christmas
Carols**

33rd Annual

Saturday

December 5 2009

Starting around 5:30pm

Oakland/Alameda Estuary

WHAT: Invitation to enter your boat in the parade or to watch the parade from your local waterfront restaurants, or at Wind River Park in Alameda, or at Jack London Square in Oakland.

COLLECTING FOOD & TOYS Please bring unwrapped toys for the Oakland Firefighters Random Acts (www.OfRandomActs.org) distributing toys to kids in need. And collecting food for the Alameda County Community Food Bank (www.accfb.org) distributing food for those in need.

AWARDS Categories include: Best Decorated Sailboat, Best Decorated Powerboat and Best Overall Decorated Boat, with a \$500 Grand Prize to the top winner.

www.LightedYachtParade.com for more info and to register. Entry deadline: Dec. 4, 2008. Entry fee: \$30 (includes a photo of your boat and a skippers goodie bag)

Hosted by
**Encinal Yacht Club,
Oakland Yacht Club
and Marina Village
Yacht Harbor.**



Gold Star Sponsor

Celebrations on the Bay

www.holmatro-usa.com

holmatro rigging hydraulics

integral adjusters
cylinders
boom vang
control panels
mast jacks

 **holmatro**
marine equipment

505 McCormick Drive
Glen Burnie, MD 21601
USA
T 410-745-2652

LETTERS

↑↓ "MMS KILLED MY WIFE"

The following is an excerpt from a group email sent to me by Doug Nash of the Dana Point-based Spindrift 43 *Windcastle*, who is a veteran of the '04 Baja Ha-Ha. It's about the tragic death of his wife Silvie Fink at Epi Island, Vanuatu. She died 12 hours after taking MMS, a so-called alternative medicine prophylactic and remedy for malaria and many other diseases. It was sold to her by another cruising couple. The 76-year-old Nash and his wife Silvie, who was from Mexico, had been cruising the South Pacific for several years.

"My life during the past five weeks has been a nightmare, but I've been supported by many people in the cruising community here and abroad, plus all Silvie's friends and relatives back home in Mexico and in the States. The outpouring of grief has been overwhelming. But no one else can answer all the questions people have asked about what happened to her, so I must do that. Here is a summary:

"While in Port Vila, Silvie decided to purchase some MMS that she'd heard about from a cruising couple. The guy is from Belgium and his wife is from California. I was not happy about her wanting to try the stuff, but I didn't interfere because I knew nothing about it at the time. Besides, she was a grown and savvy woman with lots of experience with all kinds of good and bad medicines. She'd even done a little internet research on MMS over several weeks before trying it. Neither of us thought she would be in any danger from taking it. How dreadfully wrong we were!

"We left Port Vila on August 4, and sailed 90 miles north to Epi, which is another island in the Vanuatu group. We anchored at Lamén Bay the day after their annual canoe race festival. Having decided to stay an extra day at the nice anchorage, Sylvie decided to try MMS. Its proponents had told her that it would prevent malaria, which is prevalent in this part of the world.

"From almost the moment Silvie drank the mixture of MMS and lime juice — which she'd brewed up according to the



instructions of Jim Humble, the principal proponent of the stuff — things went wrong. She became nauseated, and was soon both vomiting and suffering from diarrhea. But since the MMS literature emphasized that this was a normal reaction, she assumed it would pass. It didn't.

"It turned into a day of torture, with Silvie gradually getting worse, to the point of having severe abdominal pains, then urinary pains. I helped her all day, bathing her, comforting her and trying to get liquids into her. But she couldn't keep anything down. About the time it started to get dark, she began to feel faint. That's when I became fully alarmed. She fell into a coma while I was on the VHF calling for assistance.

"With her unresponsive, I put out another radio call, this time for immediate emergency care. Fellow cruisers rushed to our boat within minutes. For over an hour we administered CPR and oxygen. But neither they, nor an adrenalin shot administered by a physician from the village, were able to revive her. Sylvie died aboard *Windcastle* around 9 p.m., just

So, what's holding you back?

You can trust Svendsen's stanchions and lifelines. Unlike others on the market, Svendsen's stanchions are double-walled for extra strength. Our rig shop and metal shop craftsmen have the most experience in the business – and because they're boaters too, they understand how important quality is.

(particularly when quality is all that stands between you and an unplanned swim).



Now through October 31, buy 4 or more stanchions and get **25% off lifelines.**

 **Only at Svendsen's.**

Call **510.522.2886** to schedule.

Subject to parts and availability. Offer ends October 31, 2009. May not be combined with other offers or discounts.



**SVENDSEN'S
BOAT WORKS**

1851 Clement St. in the Alameda Marina
Phone: 510.522.2886 • web: svendsens.com

**BONUS
OFFER:**

FREE POLISH & WAX

with your bottom job from Svendsen's!

Mention this ad when you schedule your haulout.



Glove It Or Leave It



Full-Finger \$21.99 3/4-Finger \$19.99

West Marine Sailing Gloves

Not to put too fine a point on it, but your epidermis is no match for even the softest, supplest yacht braid when a runaway sheet or halyard goes zinging through your hands. If you'd prefer to retain your full complement of skin cells, better get a glove on.

Rather than turning their hands into hamburger, millions of sailors around the world rely on our West Marine Sailing Gloves. They're tough, comfortable, effective and affordable. Amara synthetic leather palms won't get stiff, crack or shrink. Elasticized mesh backs ensure a proper fit and drain in a jiffy. Contoured for comfort, we also make them in sizes especially for women.

Great protection. Great value. No wonder our gloves are the ones more sailors choose than any others.



Find West Marine Sailing Gloves at our
Alameda Sailing Superstore!

730 Buena Vista Ave. • 510-521-4865

We have 17 stores in Northern California.

Log onto westmarine.com to find the store nearest you.

LETTERS

12 hours after she'd taken that fatal drink of MMS. Her body was flown back to Port Vila the next day and put in the hospital morgue. I brought *Windcastle* to Port Vila the next day.

"Since then, there has been — because Sylvie hadn't died a natural death — a three-week-long police investigation involving Vanuatu criminal investigators. For one thing, it's illegal for anyone to promote or sell MMS as a medical remedy in Vanuatu. Australian joint command investigators, who aid in law enforcement in Vanuatu, also became involved. That led to a court order and, eventually, a senior pathologist's being flown from Melbourne to conduct a post mortem autopsy. That was two weeks ago. Then Sylvie's son and daughter agreed that her body should be flown to New Zealand for cremation.

"Last week, I accompanied Sylvie's body to Auckland by plane. I was present for the cremation and arranged to have her ashes sent to her daughter Aretha in Mexico City. I'm now back on *Windcastle* in Port Vila, where I await the results of the autopsy from Australia's Victorian Institute of Forensic Medicine in Melbourne. I'm also dealing with the need to secure our boat against the approaching cyclone season, which may mean having to sail her to another country.

"My heart has been absolutely crushed by the sudden loss of my dear wife Sylvie. It's so shocking I can hardly believe it. I miss her immensely, and *Windcastle* is empty without her presence. But with all of her relatives and friends, Sylvie, who brought so much joy and happiness into the world and to us, will live on forever in our hearts and minds. I've been told that the villagers at Epi, who had been so entertained by Sylvie's dancing the night before she died, have built a shrine to honor her.

"As for MMS, I wish I'd done a better job of preventing Sylvie, who had become the love of my life, from messing with it. I know now that it's a dangerous, toxic chemical which, if ingested, can be lethal. MMS killed my wife, Sylvie."

So ends Doug's letter.

John Nelson

Crew on *Tres Estrellas*, 35-ft Horstman tri
Cat Harbor

Readers — We feel terrible for Doug's loss.

We looked up MMS, which stands for Miracle Mineral Supplement — oh boy! — at a site called the Alternative Medicine Network. There we learned that the "miraculous" product, which is actually chlorine dioxide, and which needs to be "activated" by vinegar or lime juice, was accidentally "discovered" by Jim Humble. He's a gold miner rather than a chemist or physician, and supposedly stumbled upon it while prospecting for gold in South America. According to the literature, "the proof of the efficacy of this simple protocol was in successfully helping over 75,000 people in several African nations — including Uganda and Malawi — rid themselves, primarily of malaria, but also hepatitis, cancer, and AIDS." As we continued to read, we began laughing so hard we never got to the part that we're sure claimed that MMS isn't generally available because of the vast global conspiracy by the medical profession, big pharma, the American Cancer Society and others. If it weren't so terribly tragic, it would be hilarious.

We're not sure where the couple who sold Sylvie the MMS are right now, or if some authority will charge them with something along the lines of wrongful death.

↕ PUBLICITY STUNTS REFLECT POORLY ON SAILING

Your message about 13- and 15-year-old girls — Laura Dekker and Abby Sunderland — being too young to sail around the world is bang on. Or is it?

NOW IN
SAUSALITO

Hanse 

and

 Moody®







THE NEW
HANSE 400

400* 

320 350 370* 430* 470* 540e 630e

*epoxy option

Compare our pricing
against the competition

-  Ground breaking interior design
-  Multiple layout options (Individual Cabin Concept)
-  Modern, award winning performance cruisers
-  Self-tacking jib engineered into the HanseYachts design
-  Epoxy hulls (option up to 54 ft)
-  Safe, comfortable, fast & easy to sail

Hanse Yachts US

New office:

Larry Mayne Yacht & Ship Brokerage
310 Harbor Dr., Sausalito, CA
(near West Marine)

www.HanseNorCal.com

Larry Mayne | 650-888-2324

George Higbie | 415-672-4123

John Saul | 415-332-6585

hansemayne@aol.com

Larry Mayne Yacht & Ship Brokerage proudly announces our new sales office for Hanse, Moody and quality pre-owned vessels in Sausalito. Step up to the Hanse or Moody lines.

Slicker is Quicker



Team McLube Sailkote

Whether you race, cruise or daysail, you know that sailing is more enjoyable when everything works smoothly. That's why so many savvy sailors rely on Team McLube Sailkote to optimize the performance of practically everything aboard. Spray it on sails to repel water and dirt, on hulls to reduce drag and waterline scum, and on sail tracks, traveler cars and blocks to reduce friction and wear. Unlike other silicone, wax, Teflon or petroleum-based lubricants, Sailkote is a dry-film formula that lasts longer and works better in the saltwater environment. Make your boat's systems slicker with Sailkote by Team McLube.

16 oz. Spray **\$16.99**

 **West Marine**[®]

Visit our **Alameda Sailing Superstore!**
730 Buena Vista Ave. • 510-521-4865

We have 17 stores in Northern California.
Log onto **westmarine.com** to find the store nearest you.

LETTERS

While it may seem reasonable to state that these young people are not old enough to take on these challenges, it overlooks the fact that in many places 14-year-olds can fire lethal weapons and 16-year-olds can drive and join the Armed Forces, where they are put into far more dangerous situations.

If these girls can pull off just getting to the starting line, they will have accomplished more than most 'world class' circumnavigators. If they can dream it, prepare for it, work their way up to it, and then get going, I say we should let them go. After all, this is what youth and adventure are all about. Risky? No doubt. But it's also risky for kids trying to live in most inner cities in North America.

A 17-year-old sailing around the world via the Southern Ocean in a \$250,000 boat? Youth dreams big and pushes the limits. And yes, some of them don't come home. But when they do, they inspire the youth of the world with their dreams and daring.

The idea of a 13-year-old who has lived her life on a boat, who has completed some pretty good passages, and who will have a ton of support along the way, sailing around the world singlehanded might seem crazy. But let's not forget that many other countries don't coddle their kids the way we do. Kids from other places are expected to fully pull their weight from a very early age. I applaud the Dutch for taking a serious but open-minded look at whether Miss Dekker has the skills and capacity to sail a boat around the world.

Is age what really matters? After all, one of California's finest, certainly over the age of majority, has recently demonstrated that age is no guarantee of competence, knowledge, skill or judgment — even for a trip across Clear Lake. And while on that note, thank you, *Latitude*, for the great work you did showcasing the Bismarck Dinius case to the world.

Wayne Bingham
Atlante, Bris de Mer 34
Victoria, Canada

Wayne — What in the world could you possibly mean when you write, "if these girls can pull off just getting to the starting line, they will have accomplished more than most 'world class' circumnavigators?" How could they accomplish something before they even started? Besides, there are any number of six-year-olds who could motor a boat to a starting line. What's the big deal about that?

It's correct that youth dream big and push limits. That's precisely why society tries to make sure that youth has some kind of adult supervision. God knows there's plenty of evidence of what happens to kids when there isn't enough supervision. You should also note that eight-year-olds are physically capable of taking drugs, driving motorcycles and having sex. But as adults, we realize they are not psychologically or emotionally ready to make intelligent decisions about engaging in such activities. Maybe they never will be, but at least we give them time to develop to the point where they can make a reasonable evaluation about what they're getting themselves into.

Let's also talk about specific cases, because the two in question are very different. First, there is the case of Laura Dekker, the 13-year-old from the Netherlands, who wanted to depart in September on a two-year solo circumnavigation. It came as a huge relief to Dekker's mother when the courts refused to let the girl go. Though she initially supported her daughter's bid, Mom finally admitted that she thought Dekker was too young for the trip and only said otherwise because the girl threatened to never speak to her again if she didn't. Mom stated what we thought would be the obvious: Dekker isn't mature enough. We'd also be willing to argue that she might not be physically strong

380 400 421 440 500 620
New New New

25!

Lagoon 400



LAGOON HITS 25!

A quarter of a century as testament to our experience (more than 2,000 catamarans built) which has also demonstrated our drive for innovation (gull-wing bridge deck, vertical coachroof panels, large one-way hull windows, flybridge on a sailing yacht) and now confirms our confidence in the future with the launch of three new models this year: Lagoon 400, Lagoon 421 and the Lagoon 620. Lagoon invites you to celebrate this birthday with us at the 2009 boat shows.

Cruising Cats USA - Seattle and San Francisco Bay - 206.297.1330

www.CruisingCatsUSA.com



LAGOON
catamarans since 1984

Duh!

Dead simple. Pure genius!
The release "button" runs the full length of the handle so it locks and unlocks with just one hand.



LEWMAR® OneTouch Winch Handles

The first thing you'll want to do is smack yourself. "Why didn't I think of this?" A OneTouch handle locks-in and releases with just one hand. Pick it up, snick it into the winch socket and start cranking. No more positioning the handle with one hand while you twiddle a finicky little locking switch with the other. Might as well face it, after trying this handle, old-fashioned lock-in handles are just plain irritating. High strength marine-grade alloy and fiber-filled composite.

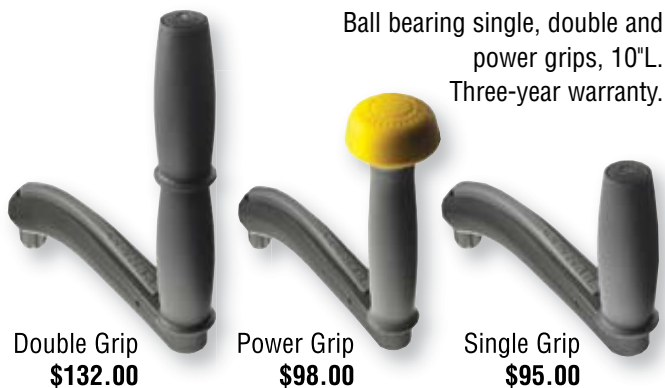

Ball bearing single, double and power grips, 10"L. Three-year warranty.

Double Grip
\$132.00

Power Grip
\$98.00

Single Grip
\$95.00

West Marine®

Find Lewmar OneTouch Winch Handles at our
Alameda Sailing Superstore!

730 Buena Vista Ave. • 510-521-4865

We have 17 stores in Northern California.

Log onto westmarine.com to find the store nearest you.

LETTERS

enough to handle some situations that would likely develop.

The case of 15-year-old Abby Sunderland is at least as extreme. While we wouldn't bet our boat on it, we wouldn't be surprised if she had the physical and emotional chops to do what her older brother Zac did. But the problem is that she wants to surpass him on two counts. Abby wants to do it while she's two years younger, which is pushing it a little, but she also wants to do a non-stop circumnavigation in six months via the Southern Ocean in an Open 40. This is a supremely greater challenge, sort of like the difference between climbing the highest peak on Catalina and climbing Mt. Everest. In the last Vendée Globe, which is essentially the same route that she's planning to take, only 12 of the 30 highly experienced and well-equipped sailors managed to complete a similar course. So in the case of Sunderland, we're talking either the monumental arrogance of youth or, more likely, a monumental ignorance of the dangers of the route. It strikes us as being like a novice surfer's wanting to catch her first wave at the Pipeline.

But it all comes down to risks and rewards, doesn't it? Since you acknowledge that 'some won't come home', we're curious about what kind of mortality rate you deem to be acceptable for female sailors in their early and mid-teens. And even if they do survive, there is no guarantee that they'll be the same when they come back. The great Ellen MacArthur, who was a very experienced ocean racer before she took off to set an around-the-world record, has never been the same person since. So even if these girls survive, and survive with their faculties intact, you still have to ask yourself what their lives are being risked for. A segment on Good Morning America? A minor book deal? In our opinion the risk/reward ratio has reached the point where these things are nothing but publicity stunts and, as such, reflect poorly on sailing in general.

↑↓ NEREIDA STARTS NON-STOP CIRCUMNAVIGATION

While refueling this morning at St. Peter Port, Guernsey, I noticed a sailboat that appeared to have spent the night at the fuel dock. Her name was *Nereida*. As the dock was crowded, the surge significant, and the woman on deck apparently alone, I offered assistance casting off. When I asked if she was singlehanded, the woman said she was. She asked if we read *Latitude 38*. Since we're from San Francisco, we said that of course we do. Then she told us that she had been written about in *Latitude* several times.

Now that we have internet access again, I've searched *Latitude* for *Nereida* references, found some, and am now confused. An article from June 30, 2008, has *Nereida* lost on the beach between Acapulco and Zihuatanejo. But an October 31, 2007, article had *Nereida* leaving Cocos-Keeling bound for South Africa. It's definitely the same boat and person — Jeanne Socrates. Both boat and person seemed undamaged in '09 when we saw them in the English Channel. How do you explain this?

Shirlee Smith & John Forbes
Solstice, Sceptre 41
San Francisco

Baja Ha-Ha '07 / Currently cruising in Europe

Shirlee and John — The very simple explanation is that it's not the same *Nereida*. As reported in the August 2008 issue of *Latitude*, the original *Nereida*'s autopilot failed, and drove her up on a beach just short of Zihua — and just 50 miles short of Socrates' completing a singlehanded circumnavigation. The boat was a total loss. Thanks to an insurance settlement, the irrepressible Jeanne was able to commission a new *Nereida*, this time a *Najad 380* instead of a *Najad 361*. That's the one you



Doyle APC



- :: Doyle's Asymmetrical Power Cruiser fills the gap in your downwind inventory
- :: Easy to set and douse with a spinnaker sleeve
- :: Reaches faster than a genoa, runs like a spinnaker—without a pole or hardware
- :: Stable and easy to trim
- :: Your choice of colors

www.doylesails.com

DOYLE SAILS • 2035 Clement Ave • Alameda, CA 94501 • 510-523-9411
San Francisco



THE SAILMAKERS WHO MAKE IT POSSIBLE.

Artistic Forgeries



Forged Shackles

When it comes to shackles, you shouldn't just accept a forgery, you should insist on it! Shackles have a tough job to do (usually holding expensive bits of your boat together), so it makes sense to buy the toughest, strongest, most reliable shackles made. Those would be the brilliant forgeries by Wichard.

These extraordinary shackles are created by drop forging 17.4 PH stainless steel, then painstakingly polishing them to a brilliant finish that defies the crevice corrosion which can cause lesser shackles to fail with catastrophic consequences.

If you want to skimp on something, go buy a forged painting. But don't skimp on something as important as a shackle. Insist on forged shackles by Wichard.

West Marine®

Find Wichard Forged Shackles at our
Alameda Sailing Superstore!

730 Buena Vista Ave. • 510-521-4865

We have 17 stores in Northern California.

Log onto westmarine.com to find the store nearest you.

LETTERS

saw at St. Peter Port. But get this: Jeanne is planning to start



LATITUDE / LADONNA

Jeanne Socrates has a new 'Nereida' — two feet longer than the old one, seen here in Hanalei.

a second circumnavigation — this one non-stop — at the beginning of this month. (We're giving her credit for the first one.) Read more about it in Sightings.

And a tip of the Latitude hat to you, too. You folks have covered a lot of ground since the '07 Ha-Ha.

↑↓ THE BAY BELONGS TO EVERYONE

Regarding Don Perillat's letter in the September issue, the boat on the cover of August's *Latitude* is a TP 52, not a Farr 40. It makes a difference to those of us who crew on the two Farr 40s on the Bay. It probably also makes a difference to the crews of the TP 52s as well, because we're all pretty decent people, and racers who pride ourselves on being good citizens.

While the Bay does indeed belong to all, it would be really good for non-racers to note that these boats are moving a lot faster than they might seem. So while it might appear that there is enough time to cross in front of a racing boat, there might not be, and therefore the crews of the two boats might be put in jeopardy. In addition, what are actually multiple boat lengths of clearance may seem to be mere feet to someone on a slower boat who is watching a fleet of 40- to 50-ft boats coming down at them at 15-20 knots.

It bears noting that what we're doing is pushing already fast boats as much as we possibly can. And sometimes things can go a little pear-shaped, either through a mechanical malfunction or boat handling error. While we do appreciate the attention, keeping a safe distance from an obvious race course is probably a good idea.

Nick Salvador
Richmond

Nick — We enjoy racing and love shaving transoms as much as the next sailor. And we agree — for folks not used to racing, a boat coming at them at 15 knots may seem a lot closer than it actually is. Nonetheless, we think you've got everything backwards. Racing on the Bay is an exception to the normal use, which is why race organizers are required to get permits for races. People doing regular old sailing don't need a permit. So on some level, racers should always think of themselves as being the burdened vessel.

As for the notion that folks on non-racing boats should "keep a safe distance from an obvious race course," we find it ridiculous on two counts. First, race courses on the Bay are rarely obvious. For instance, sometimes Little Harding will be a rounding mark, and sometimes it won't. So how is anybody without a course sheet to know whether the fleet is going to sail right by, make a 90-degree rounding toward the Cityfront, or make an 180-degree turn and head back down the Bay? Second, there are many situations when racing boats sail upwind in the middle of the Bay to take advantage of an ebb and then hug the shore to sail downwind in the flood with their chutes up. Do you really think that folks on a six-knot boat headed from Mile Rock to South Beach Marina should have to



MODERN SAILING SCHOOL & CLUB

Sausalito, CA www.ModernSailing.com 800-995-1668

Have you been thinking about sailing?

the Second Annual

Sail Fest

Saturday, October 3rd

1 - 5pm

at Modern Sailing School & Club in Sausalito



- ▲ **Free Sailboat Rides (11am - 5pm)**
- ▲ **LIVE Music** by the James Moseley Band
- ▲ **Food** by Saylor's Landing
- ▲ **Local Vendors**
- ▲ **Boat Show**

Everybody is welcome - Attendance is FREE!

Call 415-331-8250 for more information.

Advanced Certifications in Exotic Locations



John Connolly's Moroccan Adventure

On the most recent Adventure Sailing Trip, the crew had planned to sail from the Canary Islands up to Madeira and over to Gibraltar. But heavy conditions forced them to Morocco, and they coast hopped the rest of the way. John Connolly's incredible story will be accompanied by slides. See you there - FREE!

**Golden Gate Yacht Club
Thurs., October 22 (6:30pm)**

South Pacific

\$2700 / berth
\$4995 / cabin



JUST ADDED - LEG 4

LEG 3: May 20 - 30, 2010

LEG 4: June 3 - 13, 2010

Explore the Inner Tahitian Islands and join John Connolly in this sailor's paradise! Bora Bora and Moorea are just two of the luscious and vibrant islands we will enjoy while not sailing the warm winds of this spectacular part of the world. Give us a call for more information - sign up today!

Get your ASA 106, Advanced Coastal Cruising

**Leg 1 and 2
SOLD OUT!**

Get Your Captain's License



Nov. 7 - Dec. 6
Work Friendly Schedule

OUPV LICENSE - \$995
100 TON LICENSE - \$1195

Save yourself months of preparation time by letting Modern Sailing School & Club lead you through the Coast Guard licensing process. Our **GUARANTEED**, U.S. Coast Guard Approved course will prepare you for all elements of the exam, guide you through the application process, and conclude with on-site testing.

Feb. 15 - 27, 2010
2 week intensive

PREPARE TO TAKE THE HELM

AltMount™

2ND ALTERNATOR KITS and SERPENTINE-BELT CONVERSION KITS for High-Charge Output



SEE US
IN THE
BALMAR BOOTH
AT THE
ANNAPOLIS
BOAT SHOW

Yanmar 4jH4 Series kits offered with Balmar™ Alt.

- Charge your battery bank quicker
- Emergency backup alternator
- Electrical power when needed
- Reduced vibration
- No belt slipping
- Standard belt load
- and it's **BLUE!**



Yanmar 4jH4 Series Second Alternator Mount Kit

contact us... the "blue pulley" guys

www.altmount.com 415-773-0453

AltMount, Inc. San Francisco, CA

LETTERS

sail around the north side of Alcatraz to 'keep a safe distance from an obvious race course'? Or to make sure a racing boat having a mechanical malfunction or boathandling error doesn't T-bone them and their crew?

For the record, when we ran the boat on the cover of the August issue, we identified it correctly as a TP 52.

↑↓ WAS KANYE WEST DRIVING THE SAILBOAT?

Our crew of eight recently completed a day on the Bay. We anchored out in the Berkeley Circle and ran the 505 Worlds. Unfortunately, the day ended on a sour note.

During the 505 racing we felt completely safe. Despite being surrounded by 505s travelling at high speeds, we knew they were being sailed by some of the best small boat sailors around. Shortly after the last 505 finished, we were also delighted to see some boats practicing for the Big Boat Series. After one of the big boats headed downwind and popped their chute, they started coming our way. To my amazement, a boat similar to the TP 52s I've seen in your magazine headed right for us!

As this big boat came closer, there was no indication that they intended to obey the Rules of the Road, which requires that a boat sailing keep clear of a boat at anchor. Instead of staying clear, when the boat got to less than 20 yards of us, her crew began waving at us to move out of their way! It seemed the skipper made no attempt to avoid collision, and collide with us they did.

Could somebody please inform racers that the Bay belongs to all mariners, not just them?

This incident scared the hell out of me and my crew.

Scott Gordon

W.L. Stewart, Grand Banks
San Francisco

Scott — What you've described is not a case of bad manners, but what would seem to be incompetence or worse. We're curious what their explanation was for hitting your boat.

↑↓ COURTESY AND COMMON SENSE ON THE BAY

Your responses to letters are usually right on, and I really appreciate your ability to admit when you were wrong. Some of us old farts who have been sailing for 50 years have trouble admitting we occasionally make mistakes.

In your response to Don Perillat in the September issue, you say that had you been him, "we would have held our course and speed to the bitter end" when sailing through a fleet of large boats racing on the Bay. Having raced and cruised on the Bay and many other locations, I don't think that this was good advice, and it is not consistent with other advice you have given.

In your response to Jordan, Kelly and Marnie in the same issue, regarding a problem of there not being enough room for two boats to exit the San Francisco Marina at the same time, you state: "We can think of countless situations when we voluntarily gave up our rights to prevent a potentially dangerous situation from developing." That is good advice and consistent with what you have written in the past.

When cruising on the Bay during a weekend, I watch out for racing boats and make every effort to stay out of their way. Although the racing vessels may not have any greater rights than I have, why get in the way of a fleet of boats that are competing against each other? I think that courtesy and common sense require that boats not racing make a reasonable effort to stay out of the racing fleets. When racing, I have sometimes yelled at a cruising boat: "We're racing!" Most boats



Paradise Village™

MARINA

Treasure of the Mexican Gold Coast



Share with us our Successful combination:
Special Price | Service | Security | Location

Services:

- Electrical service, 110/30 amps
- 220/50 amps and 3 phase 100 amps
- Crystal Clear Potable Water
- Cable TV
- Garbage Collection
- Pump - out Station
- Fire Fighting Boat Protection
- 24 Hrs. Security
- Computerized gate access

Additional Services:

- Vallarta Yacht Club
- Special area for marina guests
- Restrooms
- Lockers
- Showers
- Pool and jacuzzi
- Free access to all the facilities of our 5 star hotel
- White sand beach
- Dive tank refilled
- Propane refill
- Launch ramp



CONTACT US: marina@paradisevillagegroup.com
Phone & fax from U.S. 011-52-322-22-66728
www.paradisevillage.com



SANTA ROSA BOAT CENTER

*If it's on a trailer,
bring it on up!*



Many of the expert technicians from Anderson's in Sausalito have now joined the team of skilled SRBC craftsmen that you've been trusting for more than 37 years. Call us today for all your boating needs:

- Safe, secure and affordable dry storage
- Boat winterizing and shrink-wrapping
- Engine and outdrive service/repair
- Fiberglass, gelcoat and woodwork repair
- Anti-fouling bottom painting
- Electrical troubleshooting/repair

*Conveniently located: Just take the
Santa Rosa Ave. exit off Hwy. 101*



4185 Santa Rosa Avenue
Santa Rosa
(707) 586-7900

www.santarosaboatcenter.com

LETTERS

respond by tacking or taking appropriate action to allow us to hold our course.

P.S. Your thumbnail report on cruising to Southern Cal may have been more appropriate as a separate article, rather than a three-page response to a letter to the editor.

David Hammer
Weaverville

David — Like you, we're always happy to make an effort to stay well clear of racing fleets. After all, we know how much fun it is to try to get every bit of speed out of a boat, and therefore take pleasure in not interfering with other sailors having a good time.

But in the case of the Perillats, it's our understanding that they didn't sail into a racing fleet, but rather were surprised to find themselves being overtaken by such a fleet. Such situations happen all the time on the Bay. When they do, we still think holding course and speed is the best option, as it gives the skipper of the overtaking boat the easiest and best chance to avoid hitting them. As courtesy and common sense are a two-way street, we think it's incumbent upon the skippers of racing boats not to scare the hell out of daysailing boats they are overtaking.

As for the very long response to the inquiry about sailing in Southern California, we had intended for it to be the heart of a 2.5 page article. But when it comes to laying out a magazine, there are lots of variables that aren't decided until a day or two before we go to the printer, so we have to be flexible. Having been at this for over 32 years, we ask you to trust us that we did the best we could under the circumstances. But we'll try to do better in the future.

↑↓ **TO HECK WITH FIVE YEARS, LET'S DO IT THIS YEAR!**

We saw the letter about the Delta-based Westsail 32 *Bag End* being members of the 'Over 30 Club'. Dan and Nancy Chism were recently in the Seychelles, still cruising after 30 years of living and raising three kids aboard in Antioch. They left Antioch to start their cruise almost 20 years ago, and are currently on their way to South Africa.

We met the Chisms in the Chagos Archipelago in the middle of the Indian Ocean in April '08. At the time, we were on a friend's boat sailing from Malaysia to the Seychelles. It was Dan and Nancy who convinced us to make our dreams happen now rather than making a five- or 10-year plan. They said if we waited five or 10 years, it would never happen. We took their advice! So although we're just one year into our five-year plan, we're starting our shakedown sail right now and will be setting off for Mexico in November. Although this will not be our first sailing trip, it will be our first boat. In 30 years we hope to become members of the '30 Year Club' ourselves.

Kim & James Knull
Doin' It
Maui, HI

Kim and James — Congratulations! We hope to cross paths somewhere down the line. And thank you for the Chisms' email address. The last one we tried didn't seem to work.

↑↓ **NOT ALL PETROCHEMICALS ARE EVIL**

It sure looks like those fine people enjoying "harnessing the power of the wind" in your most recent 'Lectronic are doing so thanks to the power of those nasty petrochemicals, what with that fiberglass boat and Dacron sails and all.

Brian Guck
Planet Earth

THANK YOU

To Our Loyal Customers:

After more than four decades, Anderson's Boat Yard in Sausalito will be permanently closing its facilities at the end of November. Forty-two years ago I started this company with the intent of providing the Bay's best quality workmanship in the maritime industry at a fair price. My sons, Tom and Ron Jr., and grandson Tom Jr., came into the business and fine-tuned what that service meant to our clients over the past decade. Together we built the finest boat yard on the San Francisco Bay.

As a family-run business, we prided ourselves in meeting the needs of the boating community – both on the private and commercial side. Whether you had a trailerable pleasure boat, a world class competitive boat, a multi-million dollar maxi or a commercial fishing boat, Anderson's came to define what the highest quality in labor and perfect end product meant. We've worked on everything from 12-foot sailboats to 110-foot tugs, and from yachts to San Francisco Bar Pilot Vessels, and in each case, our clients were treated to the most professional service and staff on the Bay.

Throughout the years we've weathered numerous storms – atmospheric, political and economic – but in the end it was none of the above that led to our closure. The owner of the land that Anderson's Boat Yard sits on simply inherited a new manager, who has other plans for the space we've occupied. We have been informed our lease will not be renewed under any circumstances. We are attempting to relocate to a new location in Sausalito: STAY TUNED!

My sons, grandson and I wish to thank all of our loyal customers who have become friends over the years, and to wish you well. Next month, I'll have a bit more to relate, but for now, please accept our sincere gratitude for the business and confidence you've placed with Anderson's Boat Yard since 1967.

Sincerely,



Ron Anderson

ANDERSON'S BOAT YARD

400 HARBOR DRIVE • SAUSALITO, CA 94965

(415) 332-5432 • (800) 310-5432

Fax: (415) 332-8136

andersonsboat@pacbell.net • www.andersonsboatyard.net



LEISURE FURL® BROUGHT BACK THE FUN OF SAILING

Over 4000
In Use Worldwide



"The big main on our prior boat, a Sabre 42, was too much for my wife Kathy and I to handle, so we had a Leisure Furl boom installed. The ease of handling our main reignited our love of sailing. It eliminated the stress associated with reefing and dousing the big main.

With our new confidence we bought a bigger boat anticipating retirement and more time on the water. Being able to furl the main from the cockpit keeps us in control and safe. Thanks to our Leisure Furl boom we have cruised to new places and met new friends."

Emmett & Kathy Harty
Hinckley So'Wester 51 - REGULUS

For more information, call or visit
Keefe Kaplan Maritime, Inc.



Point Richmond, CA • (510) 235-KKMI (5564)



JUST ONE OF OUR
MANY PRODUCT LINES

www.forespar.com
Ph: 949.858.8820 • Fax: 949.858.0505

LETTERS

Brian — We're not sure which boats or what 'Lectronic you're referring to, but your point is well taken. However, it's worth considering the astonishing durability of fiberglass boats and Dacron sails. Many of the fiberglass boats built 50 years ago in Southern California and other places are not just going strong, many of them are being cruised around the world. And most of them will probably be good for at least another 50 years. In addition, some cruisers are sailing around the world with Dacron sails that were built 30 years ago. All things considered, fiberglass boats and Dacron sails seem to be some of the most lasting uses of petrochemicals — wouldn't you agree?

↑↓IT'S A BIRD, IT'S A PLANE . . .

The photos you ran in the September 14 'Lectronic



CRAIG ALLENDER

of the wreckage found on Muir Beach sure looks like the fuselage of a small Piper Arrow or similar small plane. Are you sure it was a wrecked boat?

Brian McGuire
Oakland

Has Piper started installing sailtrack on the exterior of their planes?

Brian — Unless they've started to

put boat cleats on the outside of airplanes, we're pretty sure it was a sailboat.

↑↓THE ADVENTURES OF CACTUS LADY AND NACHO

I bow to the Cactus Lady and her infinite wisdom regarding the SOS sent out by Liz Clark on *Swell* for funds to help repair her boat. I — like many other sailors — return to the grind to replenish the kitty, upgrade our boat, and for other reasons. As Nacho said, "I am the gatekeeper of my destiny, and I will have my day in the sun." But hell, if someone wants to play Santa Claus for other people, who am I to stand in their way? Joy to the world!

Jerry Metheany
Rosita, Hunter 46
Mexico

Jerry — Pardon our ignorance, but who are Cactus Lady and Nacho?

↑↓I CAN PADDLE, STAND, WIGGLE AND FALL

First, regarding the Liz Clark controversy, it may have been a wee bit rash of her to make a request for money, but I'm shocked at some of the vehement responses. Some people just need to re-calibrate what it is they choose to get worked up about. If somebody doesn't agree with her request for money, just don't send her any, end of story.

As for Liz, I'd be happy to kick in to help refuel her dream, but perhaps she can offer some time aboard *Swell* to help offset expenses. I also dream about cruising the South Pacific, but regrettably don't know of anybody that I can crew for. By the way, I'm a physician — read: responsible community member and upstanding citizen. I'm also a novice sailor, having regularly sailed in ocean races out of the Morro Bay YC. But I yearn to break the coastal sailing bonds and experience sailing trips to exotic locales. Oh yeah, Liz would have to agree to teach me to surf as well. As of right now, I can just paddle, stand, wiggle and fall.



Berkeley Marine Center

The yard that works for you!



Maintenance,
repairs &
construction
of yachts &
commercial
vessels

- Lift capacity 35 tons
- Sprayed Racing Bottoms
- Full Painting Service
- Fiberglass & Gelcoat Repairs
- Rigging Repairs & Installation
- Electrical Repairs & Installation
- Engine Service & Repowering
- Propeller Installation & Tuning
- Wood Hull Repairs & Caulking
- Teak & Non-Skid Deck Repairs

Committed to the tradition of boating, and a tradition of customer service in everything we do.



Caulkery & Fuel Deck Open 7 Days

Mon - Fri 8 to 5 • Sat & Sun 9 to 5

In Berkeley Marina • 510-843-8195 • www.berkeleymarine.com

WHALE POINT MARINE & HARDWARE CO.

A FAMILY OWNED & OPERATED BUSINESS FOR THREE GENERATIONS
MARINE PARTS & ACCESSORIES, PLUS A COMPLETE HARDWARE STORE

Go to WhalePointMarine.com for additional discounts!

DOCK-RITE Boat Fenders



6.5" x 21" • **NOW \$18⁹⁹**
 8.5" x 27" • **NOW \$34⁹⁹**

GOLDBRAID Nylon Dock Lines

With approx 12" loop in 1 end.



3/8" x 15'....**\$10⁹⁵** 1/2" x 20'....**\$16⁹⁵**
 3/8" x 20'....**\$12⁹⁹** 5/8" x 20'....**\$24⁹⁵**
 1/2" x 15'....**\$14⁹⁵** 5/8" x 25'....**\$29⁹⁵**

TOILET SEAT Marine

Isn't it time to update that old toilet seat?



NOW \$19⁹⁹

AIR DRYR 1000



Handles up to 1000 cu. ft.
 Safe for marine use.

Now \$54⁹⁹

FLEECE LINED JACKET

Fleece lined. A most have for any sailor, or anybody living in the Bay Area with our multi-climates.



NOW \$49⁹⁹

CETOL Marine Finish

Long lasting replacement for varnish.



Satin Qt.....**NOW \$39⁹⁹**
 Gloss Qt.....**NOW \$39⁹⁹**
 Natural Teak Qt.....**NOW \$39⁹⁹**
 Light Qt.....**NOW \$39⁹⁹**

SHIP N' SHORE Battery Charger

12 Amp, portable, auto or manual. Ideal for marine & deep cycle.



NOW \$59⁹⁹

SIMPLE START BY BLACK & DECKER

Jump starts your car just by plugging in to your cigarette lighter (no jumper cables)



NOW \$49⁹⁹

205 Cutting Blvd, Corner of 2nd, Richmond
510-233-1988 • FAX 233-1989
 Mon-Sat: 8:30am - 5pm • Sun: 10am - 4pm • whalepoint@acehardware.com
 Go to WhalePointMarine.com for additional discounts!

LETTERS

Actually, I don't think it would be a bad deal for her. She would get to keep on cruising in trade for a temporary boat buddy and some surfing lessons. Heck, I'd even submit to a thumbs up or thumbs down inspection by her parents, just so she wouldn't be inviting a total stranger aboard. So maybe the wise and omnipotent *Latitude 38* gods will ferry this offer to Liz.

Gary Hatch
 Former owner of *Thalia*, 26-ft Privateer ketch
 Cayucos, CA

Gary — We know you mean well, but despite having graduated from medical school you're flunking *Men and Women 101*. If Liz wanted to run *Swell* as a charter boat, she could pack her Cal 40 with guys 52 weeks a year. You're not understanding what she's dedicating this phase of her life to. Offering to present yourself to her parents for inspection also proves you mean well, but that you're also clueless. Young women will make their own decisions about who they will spend 24/7 with, thank you.

But here's some good news. If you want to sail across the Pacific, you shouldn't have much trouble getting a bunk. You can meet people at the Ha-Ha Kick-Off Party in San Diego on October 25, in Cabo on November 6 at the end of the Ha-Ha, or at the Pacific Puddle Jump events: the PPJ Seminar at the San Diego West Marine on October 24 or the Kick-Off Party at Vallarta YC in Nuevo Vallarta on February 6. And don't forget to sign up on our online Crew List — as we went to press, there were no fewer than 150 skippers looking for long-distance crew. Check out the listings — and create your own profile — at www.latitude38.com/crewlist/Crew.html.

↑↓QUIT YER WHININ'

I disagree with people who are whining about Liz Clark "begging" for money. I've enjoyed reading her many reports — keep 'em coming, Liz! — in *Latitude*. So when I learned that she was in need of funds to repair the problem with her keel, I just jumped right on PayPal and sent her some money. She did not ask or expect anything. I just wanted to help.

I did the same thing when I heard that Bismarck Dinius needed money, too. His was a different need, but a need nonetheless.

My donation was a modest \$100 to both Liz and Bismarck. It wasn't going to break the bank for me, or make them rich. I just care about both causes, so it seemed like the right thing to do. Besides, I don't smoke, drink coffee, or drink that much alcohol, so I could send them the money I might otherwise have used for those things.

I don't have a boat right now and don't sail that much either. But I chartered a monohull in the British Virgins four years ago. And this summer I'm going to Belize to charter a catamaran with my wife, daughter, brother, brother's girlfriend, nephew and ex-girlfriend over Thanksgiving. The wife, bless her, approved of the ex-girlfriend coming along. I still enjoy my limited time on the water and reading about people's sailing adventures.

Vance Sprock
 Cupertino

↑↓THE GOOD SAMARITAN HANDICAP RATING SYSTEM

I did the Ha-Ha last year with my little Gemini catamaran *Double Play!!*, and had a great time. We later cruised down as far as Manzanillo, then returned north to leave the boat on the hard at Puerto Vallarta. We'll fly back to the boat in January and head farther south.

THE FINEST SAILS BEGIN WITH THE BEST SAILCLOTH

Our patented woven Vectran® sailcloth performs like the laminates with the durability of Dacron®, especially in roller furling applications. In fact, Vectran® is lighter, lower stretch, and retains its shape over a longer life than any sailcloth we've ever offered to cruising sailors. That's because Hood Vectran® is woven, not laminated to Mylar® film. And you can be sure that each sail we roll out is built by hand, with the same care and craftsmanship that has been the Hood hallmark for 50 years. To discuss your sailcloth needs – whether our state-of-the-art Vectran® or our soft, tight-weave Dacron® – give us a call today.

HOOD Sails & Service

HOOD New Sails

HOOD Sail Repairs

HOOD Furling Conversions

HOOD Pickup & Delivery



SAILMAKERS

**Outbound Yachts
New Outbound 52
with Hood Vektron
Vertical Full Batten
In-Mast Furling
Mainsail and 135%
Vektron Genoa**

**PHOTO COURTESY
SWIFTSURE YACHTS**

HOOD SAILMAKERS 466 Coloma Street, Sausalito, CA 94965

Call Robin Sodaro (800) 883-7245 (415) 332-4104 Fax (415) 332-0943 hoodsails@aol.com

Visit our website for Special Online Discount Pricing... www.hoodsailmakers.com



Ullman Sails

OUR ANNUAL FALL SALE IS HERE

Order between September 1-October 31, 2009 and receive:

15% OFF all big boat racing and cruising sails with single sail orders

20% OFF all big boat racing and cruising sails with two or more sail orders

10% OFF small boat one design sails

(Offer applies only to the Ullman Sails lofts listed below)



New Ullman Racing Loft in Sausalito!
Call Robin Sodaro – our new dealer for Ullman Racing Sails – for sales and repairs in the Bay Area!

PLEASE CONTACT A LOFT LISTED BELOW FOR PRICING AND FALL DISCOUNT DEALS!

Newport Beach
(714) 432-1860
2710 S. Croddy Way
Santa Ana, CA 92704
Dave Ullman
Bruce Cooper
Steve Beck
Erik Shampain
**Marina del Rey/
King Harbor**
Mike George
(310) 645-0196
Steve Beck
(562) 243-9710

Long Beach
(562) 598-9441
6400 Marina Drive #9
Long Beach, CA
90803
Bryan Dair
Steve Beck
(562) 243-9710
Ventura
(805) 644-9579
3639 E. Harbor Blvd.
#111
Ventura, CA 93001
Gary Swenson
Deke Klatt

Santa Barbara
Ken Kieding
(805) 965-4538
Gary Swenson
(805) 644-9579
Santa Cruz
Brent Ruhne
Ruhne Racing
(831) 295-8290 mobile
**San Francisco/
Sausalito**
Robin Sodaro
466 Coloma St.
Sausalito, CA 94965
(800) 883-7245
(415) 332-4104



Visit our website:
www.ullmansails.com

LETTERS

While back in the States, I bought some new stuff for my boats, including a 44-lb Bruce anchor, 200 feet of chain, and three gallons of bottom paint. It's all top quality, but not exactly the kind of stuff I could bring on an airplane. Luckily, my friend Arjan Bok is doing the Ha-Ha this year with this homebuilt 43-ft cat *Rotkat*. Although Bok is anxious to show off his cat's speed, he has nevertheless offered to carry all my heavy stuff to Puerto Vallarta. So it sure would be nice if the Ha-Ha folks could adjust his handicap in return for his carrying the extra weight to help a fellow sailor.

Don Parker
Double Play!!, Gemina 105Mc
Alameda

Don — It's great the way cruisers help other cruisers. We'll plug that info into the program that calculates the handicaps for each boat, so don't worry, he's covered.

HA-HA VETS SHOULD FLY THEIR FLAGS PROUDLY

I love the idea that the fireboat in San Diego, with all its hoses squirting, will be leading a parade of boats out to the Ha-Ha starting line this year. And that it's likely there will be other spectator boats coming out to the starting area. I think Ha-Ha vets should fly their old burgees. We'll be there with our '07 flag flying!



NICHOLS BOATS

Debbie Farmer
Oasis, Mariner 48
San Diego

It won't be raining, but cruisers are advised to wear their foulies for the start of the Ha-Ha.

Debbie — It should be something. We'll see you there.

"NO WAY WILL A PRETTY BITCH BEAT ME!"

For two years, I cruised with my dog Perra Bonita aboard my Gulfstar 41 *Someday*. But last year I left her home when I went cruising, and I missed her dearly.

Other than the cost of airfare back and forth, and finding a place to stow her travel house, I had no problems with her in Mexico. I obtained a 'Pet Passport' that shows all her shots. It was cursorily examined each time I returned to the U.S.

Perra Bonita is a 70-inch-long mutt who loves kids and who could outswim Mark Spitz. At Matanchen Bay, she swam nearly one mile from the boat to where I was on the shore. I think she was worried that I was spending too much money — or maybe getting too drunk to drive the dinghy home. I believe she was perfectly capable of running the dinghy, and not only that, could most likely have landed it in 3-ft surf.

Perra Bonita doesn't have a death wish, though. While exiting the river at Tenacatita Bay, big rollers — and I mean huge! — started to break just as we hit them with the dinghy. My dog was smart enough to bail. To restore her faith in my ability to negotiate waves, I made her wait until we were outside the surf line before I let her reboard. When she shook herself, she sprayed my hair and clothes.

Bill Nokes
Someday, Gulfstar 41
San Juan del Sur, Nicaragua

Bill — In a remarkable coincidence, Mark Spitz just dropped



La Paz, Baja California Sur, Mexico

Reserve Your Slip
in the Sea of Cortez Now

Join us for the
**BAJA HA-HA
BEACH PARTY**
Thurs, Nov. 19
Papas & Beer
Beach Club

**DISCOVER THE FINEST MARINA
IN BAJA WITHIN A LUXURIOUS
RESORT SETTING.**



MARINA COSTABAJA is located only minutes from downtown La Paz and offers the closest access in Baja to the World Heritage Site islands on the Sea of Cortez. Phase II neighborhoods are currently under construction, including Las Colinas Hillside Homes alongside the golf course and the luxurious VistaMar Residences and Casitas. Both afford homeowners sweeping water views and the opportunity to live with the marina and first-class resort amenities right in their own backyard.

The safe and protected double-basin marina features 250 slips from 30 to 200 feet, ready to accommodate vessels up to 220 feet. Built-in pump out stations, as well as TV and internet access are available at each dock, along with 24-hour security and a complete suite of TBC (Total Boat Care) services from the professional, customer satisfaction-focused staff.

Enjoy the Moorings Yacht Charters and the surrounding marina village, lined with colorful shops and restaurants, offering groceries, boat rentals and charter services for diving and fishing expeditions. Take advantage of the shuttle service to and from La Paz or access the 120-room resort hotel with its swimming pool, fitness room and restaurant.

Reserve your slip for winter now at Marina CostaBaja.

- Full Ownership Luxury Homes
 - Marina CostaBaja
- Pueblo Marinero (Marina Village)
 - CostaBaja Beach Club
 - Trail System
 - Espiritu Spa*
- Gary Player Design Golf Course**

* future amenities
** spring 2010

Homes from the \$400s to over \$1.5 Million

VISTAMAR RESIDENCES



Contact
Gabriel Ley
(Marina Manager) | info@costabajaresort.com
011 52 (612) 121-6225
www.marinacostabaja.com

YEAR END CLEARANCE!



YAMAHA



FOUR-STROKE YAMAHA ENGINES

- Best prices of the year!
- Last of 2009 inventory
- Very quiet, light 4-strokes
- Easy freshwater rinse hookup
- Best tender outboards available

3 Year Factory Warranty
Plus Y.E.S. Contract =
3-Year Extended Service Contract!

Outboard Motor Shop
Where the professionals shop!

(510) 533-9290
www.outboardmotorshop.com

333 Kennedy St., Oakland, CA 94606 • Fax 510-533-3374

2009 OUTBOARD CLEARANCE*



- Best prices of the year!
- Quiet, 4-stroke technology
- Unsurpassed fuel economy
- Transistorized pointless ignition
- Ideal for sailboats, small tenders

POWERED BY

**HONDA
MARINE**



© 2009 American Honda Motor Co., Inc.

Always wear a personal flotation device while boating and read your owner's manual.
5-year warranty standard on all new Honda outboard engines purchased.
Check with participating dealers for complete details.

*All makes and models. Limited to inventory in stock. 2010 models arriving soon.

Outboard Motor Shop
Where the professionals shop!

(510) 533-9290
www.outboardmotorshop.com

333 Kennedy St., Oakland, CA 94606 • Fax 510-533-3374

LETTERS

by the office. He says that while he's not as young or as fit as he was when he won all those Olympic medals, there is no way he'll be beaten by a dog.

Sailing Trivia: What boat did Mark Spitz race in the TransPac, and in what year?

↑↓NEXT STOP: CHINA CAMP

I just read the September issue, and loved hearing about different places in the Bay I can visit with my boat. I used the information to spend a few nights at Angel Island with my



COURTESY WISDOM

Clausen uses Angel Island's webcam to check out the moorings at Ayala Cove.

brother from San Diego. By the way, Angel Island has a web cam that shows the dock and mooring field at Ayala Cove. It's a good way to see how crowded it is and if the sun is out at that time.

And having now read about

China Camp in the current *Latitude*, I'm planning on doing an overnight there over a long weekend.

Greg Clausen
Wisdom, Santana 30
Marin County

↑↓"I'M APPALLED AT THE LACK OF EMPATHY"

On the evening of September 1, I received a phone call from an old sailing buddy who was obviously distressed. He called because he needed information on getting from Avalon to Long Beach with his Cal 34, and getting a berth there. My friend, who lives at Pearlblossom in the high desert, had just received an alarming call from his family that the gigantic Station Fire was threatening his community and home. He called me because, until I moved to Seattle last year, I'd kept my boat at Long Beach's Shoreline Marina.

My friend had asked the harbormaster at Avalon for a mooring, saying that he needed to get home as soon as possible. If he'd been assigned a mooring, he and his wife could have caught a ferry for the hour ride to Long Beach, where he could have picked up the car that I leave there. But the Avalon harbormaster told him the moorings weren't the property of Avalon, and he therefore couldn't give him permission to leave his boat. So my friend called me.

Ultimately, my friend and his wife took their boat to Long Beach, where they arrived at 9 p.m. The marine patrol told them that while slips were available, they had to wait until the office opened the next morning at 10 a.m. to get one. As a result, my friend and his wife sailed through the night and half the next day to get to Ventura, where they have a slip. It was hard and frustrating but they had no alternative. Fortunately, when they made it home, their house wasn't damaged.

I'm appalled at the lack of cooperation and lack of empathy displayed by the authorities at both Avalon and Long Beach! There wasn't anyone in the United States who didn't know that the biggest fire ever was burning in Southern California. I'm shocked that my friend didn't get more cooperation. Has the boating community gotten so callous as to not lend a hand to someone obviously in need?

Per Curtiss
Aquavit, Freedom 44
Seattle

COME VISIT COYOTE POINT MARINA:

The Peninsula's Complete Recreational Destination!



LIEN SALE
Saturday, October 3

Harbor Office
12:00-1:00 Viewing
1:00-3:00 Auction
\$5 park entry fee



Multihull
side ties available
up to 40 ft.

BERTHING

- Slips to 40' available
- 22' inside ties for \$85 per mo.
- Multihull side ties available
- Check out our rates!



FUEL DOCK & PUMP OUT

- Open 7 days per week
- Gas and diesel available
- Check our prices
- Free pump outs



**GREAT
WEATHER!**



BOATS TO BE AUCTIONED:

- 1971 Islander 30' sailboat CF 4592 EV
- 1965 Del Ray 24' sailboat CF 9517 CV
- 1975 Catalina 22' sailboat CF 0216 FV
- Santana 22' sailboat CF 5380 FX
- 1969 Santana 22' sailboat CF 1197 EH

COME FOR A VISIT – WE THINK YOU'LL STAY

Call us and mention this ad for a FREE One Night Guest Berth

COYOTE POINT MARINA ~ 1900 Coyote Point Drive • San Mateo

650.573.2594

Monitor Windvane Gets Highest Scores in Customer Satisfaction in the 2009 ARC Gear Test

(Yachting World, Sept. 2009)

The Monitor scored as follows (out of max 5):

	Monitor	Brand X	Brand Y
Reliability	4.8	3.3	3.8
User Friendliness	4.0	2.8	3.4
Value for Money	4.0	3.2	3.1

- Monitor placed 4th on the Top Ten list of ALL products surveyed.
- Also rated BEST windvane in the 2008 ARC Geat Test



THE GREEN SOLUTION!

The Monitor sailors
“...found the product hard to criticize, with excellent performance.”

SEE US AT THE ANnapolis BOAT SHOW!
Tent C, #31

Learn more by visiting our website.

You'll find over 5,000 windvane installation photos. Check out a sistership!



Official Sponsor
2009 BAJA HA-HA

FACTORY DIRECT
SCANMAR
INTERNATIONAL

WWW.selfsteer.com

432 South 1st St. • Pt. Richmond, CA 94804
Tel: 510 215-2010 • Fax: 510 215-5005 • Toll Free: 888 946-3826
email: scanmar@selfsteer.com

LETTERS

Per — Let's make sure that we distinguish between the "boating community" — which invariably takes care of itself — and the law enforcement agencies in Avalon and Long Beach that run the moorings and slips in those respective places. Even so, something sounds a little funny. The Harbormaster's office in Avalon is the agency that rents out the moorings, so your friend must have misunderstood at least part of what he was told. It may have been that all the moorings were taken or reserved because it was just before Labor Day weekend, one of the busiest weekends of the year there. And trust us, officials at places like Avalon have been burned countless times by earnest people who "must have" a mooring because of one claimed emergency or another. Then, too, maybe the harbormaster did a little checking and found that your friend's home wasn't in immediate danger.

That the marine patrol in Long Beach wasn't more cooperative doesn't seem right, particularly if there were open berths. Of course, your friend could have anchored off one of the oil islands for the night, then gotten a slip at 10 a.m., and would have been able to get to his house six hours earlier than he did by going all the way to Ventura.

Had we been in your friend's Top Siders and been turned down by the harbormaster at Avalon, we either would have anchored our boat off Avalon, and been careful to let the people on other anchored boats know about our emergency, or we would have taken our boat to Newport Beach, knowing that the Sheriff's Office, which rents out the slips and moorings, is open 24 hours a day, and that they always have open slips or moorings.

↑↓ BAIT FISH BUFFET

Last week three dolphins cruised through Pete's Harbor in Redwood City. Presumably they were there to take advantage of the full moon high tide and the bait fish buffet that comes



CYNTHIA SHELTON

First there are dolphins in the ocean, now they're in Pete's Harbor. Where next, Lake Tahoe?

with it. I got in our dinghy to take photos. The dolphins were toying with us a bit, but then skedaddled when too many curious boaters came out to gawk.

Cynthia Shelton
La Bonita, Lyndsey 30
Redwood City

↑↓ A WHALE OF A TAIL

On August 21, my son John and I departed Channel Islands Marina headed for Mariner's Basin in Mission Bay, San Diego, some 145 miles away. Staying inside the shipping lane, my San Juan 24 hit 7.8 knots sailing wing-on-wing, which is in excess of her theoretical hull speed. It was a glorious run in 20 knots, although having gybed in those winds once, I impressed upon my son the inadvisability of doing it again.

I was feeling good, as I'd just spent three delightful weeks in the Channel Islands with my fiancée. I'd proposed to her



Remind you of getting your sailboat serviced?

Let's face it, getting your sailboat serviced can be a painful experience. Which is why we do all we can to eliminate nasty surprises. We'll quote you a price up front, and we'll stick to it. We're Bay Marine Boatworks—the full-service boatyard. From bottom painting to complex fiberglass repair work, you will find we can handle all your sailboat maintenance and repair needs.

And this month, our new management is offering a free haul-out with every bottom job. This time, come to Bay Marine Boatworks, where your sailboat service won't feel like a root canal.

BAY MARINE

BOATWORKS Inc.
The Sailor's Boatyard

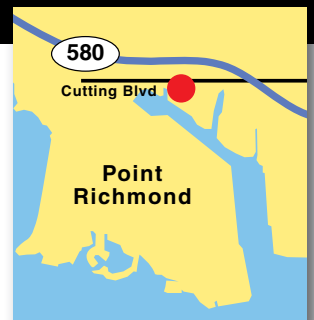

310 W. Cutting Blvd.
 Pt. Richmond, CA
 1-800-900-6646



VALLEJO MARINA

Gateway to the Bay & Delta

48-ft. BERTHS NOW AVAILABLE



Visit Our Comfortable Guest Dock

We always have room for one more!

FALL SPECIAL

- Stay three nights*
- Get the fourth night free!

*Nights do not have to be consecutive. Conditions apply. Special ends 10/31/09.

- Competitive Rates!
- Free Pumpout Stations
- Ferry Service to San Francisco
- Full Service Boat Yard and Chandlery
- Two Restaurants for Breakfast, Lunch, Cocktails and Dinner
- Great Restrooms and Showers
- Easy access to San Francisco Bay and the Delta



(707) 648-4370

Fax 707-648-4660

42 Harbor Way, Vallejo, CA 94590

www.ci.vallejo.ca.us

LETTERS

at Coches Prietos, and she said yes! In addition, we'd stopped everywhere, visiting old friends and making new ones. When we got to Oxnard, my son showed up with the car and traded places with her.

We rocketed cross Santa Monica Bay, crossed the L.A./ Long Beach shipping lanes at night with all lights on and the spotlight handy. Despite having no engine, we dodged eight container ships before we ran out of wind at the oil rigs off Huntington Beach. After we'd slatted for two hours, there was a sudden 25 knots from the southeast, meaning it was right on our nose. After it hit, NOAA was nice enough to issue a weather alert. Thanks.

Down to a storm jib and a reefed main in big and sloppy seas, John sudden yelled, "Whale!" It was a breaching whale not more than 30 feet in front of us. Its spume hit the main of my boat. I didn't think I'd be able to miss what appeared to be an 80-ft long beast, and I know for sure that we sailed over its flukes. Running through my mind in a nano-second were these thoughts: Where's the ditch kit? I need my belt knife to cut away the lashings on the kayak. Will there be time to get the paddles and my passport and driver's license from down below? Will there be time to get off a Mayday?

Miraculously, the whale didn't hit us with its flukes. "Camera!" I yelled to John. He grabbed the Canon from



JOHN PRINGLE

The fuzzy blue whale tail — it doesn't occur that way in nature, only when the shutter speed is too slow.

below, and got a photo of the whale's flukes back in the air a few seconds later. Then we saw the whale-watching boats come pouring out of Newport, packed with people who had paid \$50 each for a chance to take a photo of a whale from 200 yards away. John and I high-fived

each other, for none of the people on those boats had the remotest chance of experiencing what we just had.

It was a hard sail the rest of the way to Mission Bay, but my boy is a trooper. He was born in Bequia, so he can hand, reef and steer, and has great reserves of fortitude. When I caught some sleep, I was comfortable with him at the helm — which is more than I can say when I'm with a lot of so-called sailors.

Like my old buddies Don Street and John Smith, I'm a sailor, so my boat doesn't have an engine.

William 'Billy Bones' Pringle
Sea'Scape, San Juan 24
Mission Bay

Billy — Congratulations on your impending nuptials!

You sound like an experienced and intrepid sailor to us, so we're puzzled by why you would be concerned about gybing in 20 knots of wind. If you were doing 6 or 7 knots, the apparent wind would have been only 13 or 14 knots. Gybing in such conditions wouldn't concern us anywhere near as much as trying to dodge ships in Southern California without an engine. We admire your 'sail-only' attitude, but there are so many ships out there now.

Based on our experience and that of others, whales seem to have made a huge comeback from Alaska all the way down to mainland Mexico. This being the case, everyone sailing from California to Mexico should have a plan of action ready in the

GARHAUER

MARINE HARDWARE

*GREAT
GEAR*

See us at
the Annapolis
Boat Show

Quality stanchions and gates from Garhauer

Whether you are replacing one stanchion or upgrading your entire boat, we manufacture a complete line of stanchions, bases and gates.

- Stanchion tubes available in 3 different tip styles
- Stanchions and gates can be made removable or with fixed bases.



GARHAUER
MARINE HARDWARE

1082 West Ninth Street,
Upland, California 91786

Phone: (909) 985-9993
FAX: (909) 946-3913

email: garhauer@garhauermarine.com
<http://www.garhauermarine.com>

**BUY
ONE**

**GET
ONE**

**1/2
OFF**



Visit your participating Harken dealer before November 30, 2009 to receive a second winch at half price.

Select models only. Sizes 32-53: chrome, aluminum, manual, electric, self-tailing, plain-top, Quattro

HARKEN[®]
INNOVATIVE SAILING SOLUTIONS

www.harken.com

LETTERS

event of a collision with a whale.

↑↓ **BOY, YOU SAID A MOUTHFUL**

In last month's *Changes* you ran a photo of just two tips of the sun showing over the horizon because the rest of it



COURTESY DAYDREAM

had been blocked by the earth in a solar eclipse. When the earth, moon and sun are all aligned — which they had to be in this case — it's called syzygy.

Ken Schulze
Williwaw, Hobie 33
Santa Cruz

Things may have to be syzygistic for this to occur, but we don't think that's the name for two tips of sunlight peeking over the horizon.

some name for just the two tips of the sun showing over the horizon.

Ken — Thanks for that answer. But we're actually wondering if there isn't

↑↓ **EVERYONE PAYS AS FEW TAXES AS POSSIBLE**

The article about Bill Joy's 190-ft sailing yacht *Ethereal* was interesting — but I didn't like the photo showing the oversized surfboard flying a foreign flag. Having often cruised the ECW, I'm sick and tired of owners who are ashamed to have their national flag flying on their boats. And that goes for Tiger Woods and his big powerboat on Lake Worth, Florida, too.

I know foreign flags are flown to avoid taxes, but I believe that if you use the benefits and privileges of your country, you should fly that country's flag. Maybe we should make the owners of such boats turn in their passports. I bet many of these 'foreigners' wear American flag buttons on their suits at political rallies. And I'm writing this as a tree-hugging, bleeding-hearted liberal.

Jack Mooney
Utopia Too, Westerly Centaur 26
Hudson, Florida

Jack — There are several good reasons why all big yachts — which for a whole different set of good reasons are owned by corporations rather than individuals — are flagged outside of the United States, and these reasons have nothing to do with being "ashamed" of this country. First of all, flagging a vessel outside of the United States means that the corporation can have anyone be the master. Because of what many perceive to be archaic U.S. law, foreign citizens can't master a U.S.-flagged vessel in U.S. waters. Second, vessels flagged outside the United States do not need to provide USL&H Workman's Compensation, which means fewer hassles and lower insurance premiums. In addition, foreign-flagged vessels don't need to report payroll taxes for employees.

But let's not kid anyone, the main reason such vessels are flagged outside the United States is to save money on taxes. People might have differing opinions on the morality of taking steps to limit one's tax liability, but it's pretty clear that just about everyone does it. For some people, it's buying stuff over the internet from out-of-state sellers; for others, it's taking delivery of expensive jewelry or art at a second home in a no-sales-tax state, and for yet others, it's using the income tax code to their best advantage.

It would be easier to get angry about it if passing out huge



Baja Sur Travel Tip #12
**PRACTICE
CPR.**

You can help keep the big game fish of Baja Sur healthy by practicing CPR – Catch/Picture/Release. Just go to mybajasur.com for savings in world renowned Los Cabos and the nearby East Cape, Loreto and La Paz. You'll discover discounts on big game fishing • Reduced rates and bonus nights at 5-star resorts, all-inclusive hotels and small hideaways • Complimentary golf • Discounts on spa treatments, fine dining, outback adventures and more. In Baja California Sur, you can become an expert in CPR.



Los Cabos



East Cape



Loreto



La Paz

Baja Sur

Baja California Sur

1 877 MY BAJA SUR
mybajasur.com



México



South Beach Harbor is a great way to experience San Francisco. Boats of all sizes are welcome in our protected deepwater harbor. Bring your boat to South Beach and enjoy all the attractions of the city.



- Two guest docks for boats up to 125'**
- 20 guest berths up to 50'**
- Casual and fine dining nearby**
- Adjacent to AT&T Park**
- Easy access to transportation**
- 24 hour security**
- Free pump-out stations**



For Reservations:
415.495.4911 (x0)
fax: 415.512.1351
sb.harbor@sfgov.org
www.southbeachharbor.com

LETTERS

tax breaks to favored friends wasn't so popular with cities, states and the federal government. Just the other day Berkeley — about as left-wing a place as there is in the universe — fell all over itself rushing to give mighty Bayer \$100 million in tax credits to keep and upgrade its facility in that city. The state of Michigan has given the most lucrative Hollywood studios tens of millions in tax credits to film in their state rather than California. And there is a whole host of states that 'steal' from neighboring states by having either no state sales tax or no state income tax.

Given such an uneven playing field for being assessed taxes, and the number of people in the higher levels of government who have been found to have outright cheated on their taxes, it's not hard to understand the reasoning by the people who own the corporations that own the big yachts.

↑↓ **BOOZERS IN BAJA ARE A BORE**

Can you tell me what the policy is on drinking in the Ha-Ha, both while offshore and at the stops along the way? I'm a moderate drinker, but I don't like being around people who drink to the point they make fools of themselves and endanger themselves and others.

Name Withheld By Request
San Diego

N.W.B.R. — We're on the same page as you, because while we do enjoy a few cocktails a week, we detest irresponsible drinkers. Our recommendation for people in the Ha-Ha — and everybody else sailing — is to not drink at all while underway. We know some folks will have a glass of wine with dinner, but we think anything beyond that would compromise safety and therefore be foolish. While ashore, those who choose to drink need to do so responsibly, for not only are there more physical dangers in Mexico — potholes in sidewalks, rickety ladders up piers, and shorebreaks — but everyone in the Ha-Ha is also a representative of the United States and sailing. The general rule is that you should behave in public the way you would behave in front of your best friend's children.

Once everybody makes it to Cabo, of course, a little celebration is in order. That's why there's an annual gathering of a couple of hundred Ha-Ha folks at Squid Roe on Thursday night for group dancing and, for those who wish, cocktails. It's usually quite wholesome for the first couple of hours, but once the younger folks and locals take over, it sometimes gets a bit more adult. While the large security team at Squid Roe is pretty lenient, the police on the streets will not put up with noisy or obnoxious drunks. Misbehave in public, and six serious cops will jump out of the back of a white pick-up and unceremoniously take your butt to jail. Unlike cops in the States, they won't discuss the matter with you, they'll just haul you off. And Lord help you if you try to resist. We're pleased to say that, despite all the fun Ha-Ha folks have had in Cabo, we're not aware of any who have had so much fun that they were hauled off to jail.

For 15 years the Ha-Ha has been a sailing and social event, not a drinking event, and we're confident everyone will do their part this year to keep it that way.

↑↓ **"DOING MY PART FOR THE ECONOMY"**

Having done the Ha-Ha last year as a hired gun, I was hoping to do it again this year with my new-to-me boat. Unfortunately, it looks as if I won't be able to blow the Ha-Ha staff's minds with my newest boat until next fall's Ha-Ha 17.

After having some issues with the owner of the boat I sailed aboard to Cabo, I shut down my yacht repair business and

Come visit us today!

SOUTH BEACH SAILING CENTER

at the
beautifully renovated Pier 40 in San Francisco

South Beach Riggers

**TIME TO REPLACE
THOSE LIFELINES?**

Keep your boat and your loved ones
safe...and on board.

**25% OFF LIFELINES
PARTS AND LABOR**

Offer valid through October 31, 2009

TWO LOCATIONS

399 Harbor Dr. • Clipper Marina • Sausalito • 415.331.3400
Pier 40 • South Beach Harbor • San Francisco • 415.974.6063

Be Clean and Green



- Mobile Service:
We Deliver!
- Washing
- Waxing
- Varnishing
- Interior Cleaning



Complete Yacht Care

*Serving the entire Bay Area
for more than 20 years*

(415) 661-2205

Pier 40, South Beach on the Embarcadero • San Francisco

Call Toll Free **888-828-6789**

westwinddetailing@sonic.net
www.boatdetailing.com



CAL MARINE
ELECTRONICS



Sales - Installation - Service - Integration

- Radar
- VHF
- GPS
- Antenna
- Auto Pilot
- Instrumentation
- Chartplotter
- HF/SSB / e-mail
- Electrical
- Checkup

Serving SF Bay with name brand products
and professional quality services since 1952

Done right ... priced right.

415-391-7550

Pier 40 The Embarcadero, SF, 94107
www.calmarineelectronics.com

*Design, Fine Yacht Upholstery,
Fabrication, Etc.*



YACHT: LIN MAR

**NORTH
BEACH
MARINE
CANVAS**

415.543.1887

nbmc@earthlink.net

www.northbeachmarinecanvas.com

Pier 40, The Embarcadero
South Beach Harbor, San Francisco

Adjacent to South Beach Harbor and AT&T Park • Close to dozens of fantastic restaurants and shops

HOGIN SAILS

Bring your sails by
for a free evaluation.



- ★ New Cruising and Racing Sails
- ★ Full Production/Service Loft
- ★ Repairs, Recuts, Roller-Furler Conversions
- ★ Strontrack, ATN, Dutchman, Nauteek SC200
- ★ Canvas Work
- ★ Call for Expert Advice

510.523.4388

Providing the Bay Area with
Quality Sails and Service
since 1978

Hogin Sail Makers
1801-D Clement Ave.
Alameda, CA 94501

Mon-Fri 8:30am to 5pm
Saturday by appointment only

sales@hoginsails.com
service@hoginsails.com
www.hoginsails.com

LETTERS

went into chartering. By doing this, I figured I could at least control who goes and stays on my boat. (By the way, I'm happy to report that the owner of the boat I did the Ha-Ha on and I have made amends and become good friends.)

Anyway, my new boat is *Cloudia*, a 1920 85-ft LOA Colin Archer design. She's currently at the Driscoll yard in Mission



COURTESY CLOUDIA

It's hard to believe but Capt. Blanchard's other boat is an Islander 34, which he calls "rocket fast."

Bay getting a refit. *Cloudia* is probably one of the last of the big wood hulls to be re-planked. I even had a hard time finding vertical grain planks — and I grew up in the Northwest where my family was in the lumber business. The problem in finding the wood is that the government won't let us harvest the good trees needed for this purpose anymore. But by buying a semi-truck and scrounging from Alaska all the way down to Eugene, I managed to get 7,000 board-feet of Alaskan yellow cedar to redo the entire hull one last time. You don't want to know what it cost for the wood or the fastenings, but I'm pretty sure that I'm stimulating the U.S. economy more than the government is.

My restoration was going to be the whole shebang — planks, deck, machinery — the works. But then I got a fright!



COURTESY CLOUDIA

Timber! That's what's inside big wood boats.

The man who was going to plank the boat backed out at the last second. It turned out to be a blessing in disguise, because we decided to cold mold the hull instead of replanking it, and it's turning out much better all the way around.

To all but the Colin Archer purists — who live in Norway — *Cloudia* will still look planked. I sometimes complain about the refit's being an expensive pain, but I just love old wood boats because they have something that the newer ones lack. For instance, I have an Islander 34 that's a rocket ship. While she's a blast and all, *Cloudia* is just classier in my book. Believe it or not, she's faster, too. Yeah, my big Colin Archer really hauls ass. The trick is stopping her!

Work hard, sail free!

Captain Thaddeous Blanchard
Cloudia, Colin Archer 85
San Diego

Thaddeous — Your boat, which has more character than 25 fiberglass boats, would certainly be welcome in the next Ha-Ha. Good luck with the refit — and thanks for all that you're doing for the economy.

⇕ DROP OUT, BECOME A BILLIONAIRE

We think you made a mistake when you corrected George

Why settle?



Ballena Isle Marina

Alameda 510.523.5528

Jack London Marina

Oakland 510.834.4591

Treasure Island Marina

San Francisco 415.981.2416

Martinez Marina

Martinez 925.313.0942

*Official
Sponsor*

**2009
BAJA
HA-HA**



You don't settle for less, why do it with your marina? Join one Almar marina and gain access to seven Bay Area marinas. Almar's reciprocal program takes the hassle out of your boating weekend. A simple call to the marina office and you can spend the weekend at Jack London Square or Treasure Island. Maybe a trip to a few of Almar's seven Southern California marinas. We make it so easy you may find yourself using your boat.

Almar boaters receive a 10% discount on any fuel purchase at Jack London Square and Ballena Isle Marina. Jack London Square Marina has just upgraded it's fuel dock with high speed fuel dispensers and now has the fastest pumps in the Bay Area. You don't have to settle anymore.

Almar is the largest operator of saltwater marinas in the country. Almar Marinas provide a wide range of services and programs that few marinas or yacht clubs offer. Some of these programs include: monthly boating seminars, boat handling classes, navigation courses and organized outings to local anchorages. Each marina offers wireless high speed internet access, which can be used with your reciprocal privileges at any Almar Marina. To see the difference, visit one of our marinas this weekend.



almar.com

LETTERS

Backhus in his *Changes in Latitude*. He said Paul Allen's *Tatoosh*, which was anchored near Backhus' Deerfoot 62 *Moonshadow* at Taormina, Sicily, was 200 feet. You said she was actually 420 feet. Well, when we were anchored near her at Falmouth Harbor, Antigua, a few years ago, we understood her to be about 302 feet. By the way, she had a 40-ft powerboat and a 40-ft sailboat — both Hinckleys — on her sidedecks.

Barritt Neal & Renee Blaul
Serendipity, Peterson 46
 San Diego

Barritt and Renee — Allen has had so many large motoryachts that we get confused. But you're right, *Tatoosh*



WEBB LOGG

is 302 feet, which makes her the 26th largest yacht in the world. We'd been thinking of Allen's newer yacht, the 413-foot *Octopus*, which is the 8th largest yacht in the world.

It's hard to keep all of Paul Allen's motoryachts straight. This is 'Tatoosh', which is indeed 302 feet long.

While doing research, we were surprised to learn that Larry Ellison is no longer the sole

owner of the 453-ft *Rising Sun*, the sixth largest privately owned yacht in the world. According to Wikipedia, David Geffen, a brilliant businessman, is now listed as a co-owner.

For those keeping score, if you eliminate motoryachts owned by Arab heads of state, the biggest private motoryacht in the world is Russian Roman Abramovich's recently launched 548-ft *Eclipse*. *Rising Sun* is second and *Octopus* is third.

Kids, are you having trouble convincing your parents that you should drop out of college or university? Here's your best argument: Paul Allen dropped out of Washington State University and convinced Bill Gates to drop out of Harvard so they could start Microsoft. Larry Ellison dropped out of the University of Illinois and then the University of Chicago before living hand-to-mouth in Berkeley and starting Oracle. As for David Geffen, he dropped out of what was then called Santa Monica City College to take a job in the mailroom of the William Morris Agency, where he laid the groundwork for starting his fortune by representing rock 'n rollers.

↑↓ HURRICANE STATISTICS CAN BE MISLEADING

Just a quick note to point out that your coverage of Hurricane *Bill's* threat to St. Martin had some pretty basic historical errors. St. Martin does not get hit by a hurricane every year. In fact, since the extreme Category 4 Hurricane *Luis* in '95, there have been only two: *Lenny* in '99 and *Omar* in '08. There's a big difference between a hurricane every few years and every year.

Bob Wise
 Paradise Connections Yacht Charters
 St. Martin, French West Indies

Bob — Our sincere apologies. What happened is that we ran that factually inaccurate claim by Mike Harker of the Manhattan Beach-based *Hunter 49 Wanderlust 3*, then corrected it in the next paragraph. But as a result of having to juggle the layout at the last minute, the corrected paragraph was mistakenly left out. We hate it when we do that!

ATTENTION CRUISERS! MEXICAN LIABILITY INSURANCE ONLINE

MARINERS GENERAL INSURANCE GROUP

Now with six offices offering you local insurance service and global insurance coverage.

SEATTLE
 (800) 823-2798 • (206) 281-8144
 Fax (206) 281-8036

NO. CALIFORNIA
 (800) 853-6504 • (650) 373-0595
 Fax (650) 548-1585
 email: boomeins@aol.com
 Lic. # 0A99058

L.A./ORANGE COUNTY
 (800) 992-4443 • (949) 642-5174
 Fax (949) 642-0252
 Lic. # 0D36887

SAN DIEGO
 (800) 639-0002
 Fax (619) 226-6410
 Lic. # 0A96346

BRADENTON, FLORIDA
 (800) 914-9928
 Lic. # E051940

New!
PUERTO VALLARTA
 (949) 274-4111

Official Sponsor
2009 BAJA HA-HA

ASK ABOUT OUR NEW RACING SAILBOAT PROGRAM!

It's a Mariner's Fact:
 In three minutes a vessel will travel a distance in hundreds of yards equal to her speed in knots. For example, if your speed is 6 knots, you will travel 600 yards (1,200 feet) in three minutes.



LET'S BE CLEAR ABOUT IT...

**"Dumping sewage anywhere in
our waterways pollutes the
environment."**

Disease, contamination, low oxygen levels and unsightly water are just a few of the devastating effects of boat sewage illegally dumped anywhere in our waterways and shoreline.

It's simple: You have to plan to properly dispose of human sewage from your boat. Boats with holding tanks must pull in and pump out at shore side pump out stations.

If you have a boat without holding tanks, plan your trip to use shore side restroom facilities.

Don't waste away our waterways! Proper disposal of sewage allows the living things in our waterways to keep on living.

**IF IT'S YOUR BOAT,
IT'S YOUR RESPONSIBILITY.**

California Department of Boating and
Waterways



For more information visit our website
www.BoatResponsibly.com

AIS Made Easy!

Latest, most cost-effective
collision-avoidance solution

AIS (Automatic Identification System) receivers enable AIS-capable chart plotters and navigation software to see other vessels. AIS transponders allow other vessels to see you.

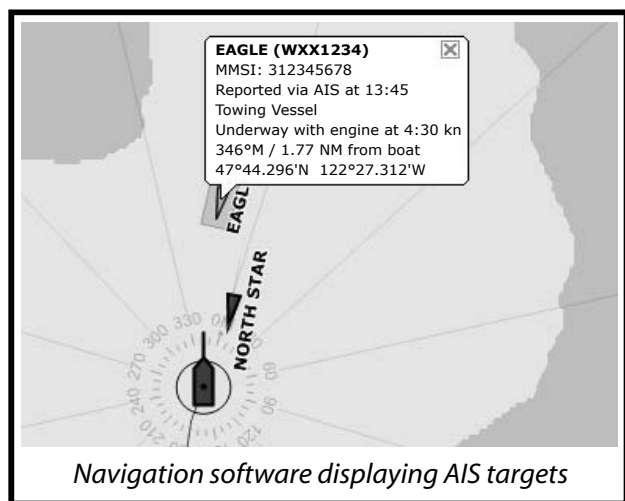

Milltech Marine offers complete, low-cost AIS solutions. Visit our web site for information on:

- AIS Receivers - featuring the Comar AIS-MULTI
- AIS Transponders - including Class B AIS
- Navigation Software
- Antennas, cables and other accessories



Order any product online and use coupon code "LAT38" to get free shipping in the U.S.

For more information contact:



(866) 606-6143
www.MilltechMarine.com

LETTERS

While St. Martin certainly does not get hit by a hurricane every year, it's gotten hit a little more frequently than you remember. We know this thanks to www.HurricaneCity.com — an extremely informative site with data based on detailed study of



MIKE HARKER

False alarm. Boats have hid in the mangroves of St. Martin many more times than the island's been hit by hurricanes.

multiple sources. The overall picture is that St. Martin has been hit, or at least brushed—meaning an eye within 60 miles — by a hurricane a total of 49 times in the last 139 years. That averages out to once every 2.8 years. But these statistics can be very misleading because, for example, St. Martin wasn't hit or brushed in the 29 years between Faith in '66 and horrible Luis in '95. To prove the inconsistent nature of hurricane occurrences, St. Martin was hit just 10 days after Luis by Marilyn. Anyway, here's the hurricane history for St. Martin for the last 15 years:

— 1995, Hurricane Luis hit on September 5 with 140 mph winds and a barometric pressure as low as 27.65. Fourteen people were killed on the island or on boats, 1,000 were left homeless, and over 700 boats — most of them in Simpson Bay Lagoon — were destroyed. Indeed, debris from many of the boats destroyed by Luis still litter the lagoon.

— 1995, a week after Luis, Hurricane Marilyn brushed the island to the south and west with 105-mph winds. Most of the buildings in Grand Case were destroyed.

— 1999, Hurricane Jose hit on October 20 with 100-mph winds, but the damage was relatively minor because the hurricane was rapidly fizzling to just 70-mph winds when it got close.

— 1999, Hurricane Lenny, with 120-mph winds, parked between St. Martin and St. Barth for November 17 and 18, and severely punished both islands. Thirteen people were killed, and the south-facing beaches of St. Martin were devastated. Since the island had been hit or brushed by five hurricanes in just seven years, insurers either cancelled policies or greatly increased the premiums.

— 2000, Hurricane Debby hit north of St. Martin. Damage was light as there were only 75-mph winds and Debby was moving away to the WNW at an amazingly fast 21 mph.

— 2008, Hurricane Omar, which had been heading right for the British Virgins, jogged to the east, and brushed St. Martin with 60-mph winds. The damage was not severe.

But that's the way it goes with hurricanes. None hits St. Martin in 29 years, then there are five in seven years, then none for another seven years. Try to make sense of that.

For what it's worth, we had our Ocean 71 Big O in the Caribbean from '86 to '96, and thank goodness she never got hit. There were two close calls, however, with Gilbert in '88 and Hugo in '89. Most people on the West Coast probably don't remember them, but they featured winds of 160 knots and 140 knots respectively, making them among the most powerful hurricanes ever to hit the Caribbean. We've had our Leopard 45 'ti Profligate in the British Virgins for the last three years, and she hasn't been hit — although Omar came very close last year. Please keep your fingers crossed for our cat and everyone else who has a boat in a hurricane zone.



MARINA BAY YACHT HARBOR

A Certified Clean Marina

www.MarinaBayYachtHarbor.com

(510) 236-1013

1340 Marina Way South, Richmond, CA 94804

*Call today
Save this winter!**



- A Sunnier, Warmer East Bay Marina
- Restaurant & Deli
- Berth to Bay in 15 Minutes
- 24-Hour Courtesy Patrol

- Deep Draft Harbor (race boat friendly)
- Nearby Boatyards, Chandleries, and Fuel

*Easy Bay
Access*

*Save 40%
Now!*



Tradewinds Sailing School and Club ~ www.tradewindssailing.com

SHAFT SHARK

**The best rope,
line and debris
cutter there is!**

Two piece unit

For both power and sail

**Now available for
sail drive systems.**



747 Aquidneck Ave.
Middletown, RI 02842

401-847-7960

Fax: 401-849-0631

sales@ab-marine.com

www.ab-marine.com

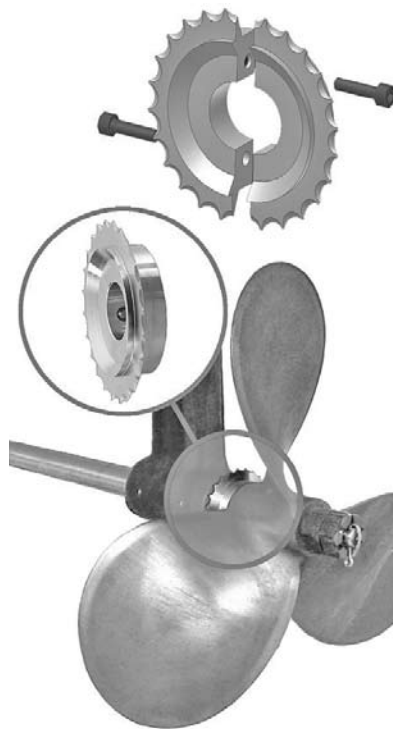

Gori propeller

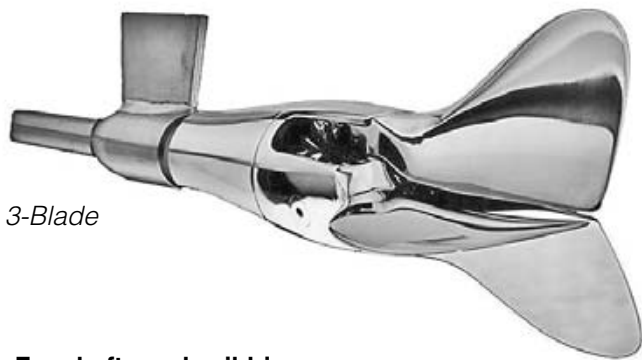

3-Blade

- For shafts and saildrives
- Both 2 & 3 blade available
- Lowest drag when sailing
- The champions choice



747 Aquidneck Ave.
Middletown, RI 02842

401-847-7960

Fax: 401-849-0631

sales@ab-marine.com

www.ab-marine.com

CALL US TODAY!

800-801-8922

LETTERS

↑↓ ANYONE DRIVING DOWN BAJA AFTER THE HA-HA?

I'll be sailing our Hunter 36 *Delight* in the Ha-Ha again this year. We had a great time when we did it in '07 — even though we had some big problems. As you might remember, once south of Turtle Bay we lost our engine, had to steer with the emergency tiller for 13 hours, and were taking on water at a little over a gallon per hour.

Anyway, I have a bit of a problem, and wonder if somebody might be willing to help me out. My wife is legally blind, so she won't be doing the Ha-Ha with us. But she and I will later cruise Cabo and the Sea of Cortez until we get tired of it. My problem is that I'd like to find a way to get my wife and dog to Cabo without having to rent a car and drive up to San Diego to get her. Is there anybody driving down to Cabo right after the Ha-Ha who would be willing to take them? Naturally, I'd be more than happy to help out with the cost of fuel. I can be reached at (916) 972-0706 or (916) 849-5961.

By the way, *Delight* is a very different boat now, as she sports 400 watts of solar power, a genset, a new steering system, and a new autopilot.

Al Miller
Delight, Hunter 36
Carmichael

↑↓ THE EVIDENCE IS IN AND IT POINTS TO PERDOCK

As a retired naval officer and sailboat owner, I have always believed that there was more than one person to blame in the accident on Clear Lake that claimed the life of Lynn Thornton. As a lifelong resident of the area, I know there is a good 'ol boy club up here. But please remember that while Deputy Perdock may have been at fault for the way he operated his powerboat, the folks on the sailboat were at fault, too. And sad to say, if you accept the helm, as Dinius did, by definition you are operating the boat. So both Perdock and Dinius should have been on trial. Not for manslaughter, but for reckless endangerment.

Skip Lethin
Lake County

Skip — If you read Latitude regularly, you know that from the outset of our coverage we said there was shared responsibility for the accident — assuming that the sailboat's running lights were not on. We put Deputy Perdock at 80% responsible, Mark Weber, the owner of the sailboat at 19% responsible, and Bismarck Dinius, who happened to be at the helm, at 1% responsible.

But if you followed the recently concluded trial in Lake County, you know that there were five witnesses for the defense — including a retired police officer — who testified that the sailboat's running lights were indeed on. Even an eye-witness for the bumbling prosecution testified that the sailboat's running lights were on!

As a retired naval officer, surely you know that the burden to stay clear is on the overtaking vessel, that a safe speed must be observed by all vessels, and that when navigating against a background of lights, you never head for the lights and try to avoid other vessels by hoping to see their silhouettes. Perdock broke all of those rules. Based on the evidence, nobody on the sailboat did anything wrong, nor was there anything they could have done to avoid being hit. That's why the jury voted 12-0 to acquit Dinius on the charges of felony BUI resulting in death and BUI, and 11-1 on operating with a BAC over .08 (that charge was then dropped by the D.A.).

With all the evidence in, it seems clear to us that there is only one person responsible for the collision and the death of



Brisbane Marina welcomes Golden Gate Charter, LLC, to our line of services.

Call Grant Gilliam for luxury yacht charter information.



(650) 773-3311
grant@ggcharter.com
www.ggcharter.com



From Hwy 101, take the Sierra Point Pkwy exit and follow the signs to the marina.

**400 Sierra Point Parkway
 Brisbane, CA 94005**

(650) 583-6975

www.ci.brisbane.ca.us
harbormaster@ci.brisbane.ca.us

Service of the Month

CARPET & CUSHION CLEANING

Professional, dockside cleaning that will leave your boat looking and smelling like new!
More sailing, less work.

ADDITIONAL SERVICES
 Bilge Cleaning • Detailing • Maintenance Washdown • Carpet & Cushion Cleaning

Fully Insured & Marina Approved
Serving the Bay Area Since 1986
Call now for a Free Estimate

510 428-2522 or 415 457-6300
www.seashine.net

Wow! Check out this 2007 mint-condition Lagoon 380!

This is the **BEST** maintained, **BEST** equipped Lagoon 380 that's been available along the Pacific Coast for the past five years!



LAGOON 380-S2

The L-380's owner, an airline pilot, liked this Lagoon so much that he's ordered a new Lagoon 400 (see p. 25). Now YOU can own this 380, and benefit from the pilot's meticulous care and attention. She includes:

- Upgraded 2 x 30 hp diesels
- Self-furling screecher on sprit
- Extra fuel and water tanks
- Webasto Hydronic heating
- Autopilot & radar
- Magnum ME 2012 inverter
- Max Prop Classic feathering props
- ...and lots more (call for details)

Cruising Cats USA - San Francisco Bay & Seattle
 Toll Free (877) 937-2287
www.CruisingCatsUSA.com

We Still Offer More!



Making boating easier – and more fun! is what a marina should be all about.

That's why Oyster Cove Marina rates number one with many Bay Area boaters. It's an exclusive yet reasonable facility of 219 berths, accommodating pleasurecraft in slips up to 60-ft long.

Oyster Cove is the private Peninsula marina closest to Blue Water boating.

Want to cruise to Sausalito, lunch at Tiburon, or sail to Angel Island? How about a day's fishing outside the Gate, or a weekend at the Delta? No other private Peninsula marina is better situated or offers nicer, fresher surroundings.

- Berths 30 feet to 60 feet
- Double Finger Concrete Slips
- Telephone Available
- Five Minutes from SFO
- Heated Dressing Rooms & Showers
- Laundry Room
- Nightly Security Patrol
- Complimentary Ice
- Cable TV/High Speed Internet
- End Ties Available at \$5.95/Ft!



OYSTER COVE MARINA

385 OYSTER POINT BOULEVARD #8A
SOUTH SAN FRANCISCO

(650) 952-5540

LETTERS

Lynn Thornton, and that person is Chief Deputy Russell Perdock. We hope he is prosecuted. A lot of people are assuming that the accident was the result of Perdock being drunk, but there doesn't seem to be evidence to support such a belief. We think he was just getting his kicks by recklessly hauling ass through the black night — as he testified he'd done many times before — without being able to see because it was black out, he wasn't wearing his prescription glasses, and because the speed would have made his eyes water up. It was just an instance of really poor judgement.

↑↓ TELL ME THERE'S A SPEED LIMIT ON CLEAR LAKE

I'm surprised that I haven't heard anything about it, but can you please assure me that, in the light of the death of Lynn Thornton, there is now a 5 mph speed limit on Clear Lake after dark?

Carl Chesney
Ghoolie, Catalina 22
Sacramento

Carl — An attempt was made a few months ago to establish a night time speed limit but it was quickly quashed by Lake County's powerboater-filled Clear Lake Advisory Committee. Regardless, the California Harbors and Navigation Code does require that all vessels "be prepared to stop within the space of half the distance of forward visibility." Just how much forward visibility does one have on a pitch black night? Not much.

By the way, having travelled from shore to our anchored-out boats well over 100 times this year — including in Mexico, the Caribbean and Catalina — we consider ourselves to be experts on operating sailboats and fast dinghies at night. We can report that on nights when the moon is full or close to it, visibility is actually pretty good. But on moonless nights, such as the night that Perdock rammed the boat Lynn Thornton was on, you're all but blind. No wonder two unlit pangas slammed into each other behind Profligate one night last December while we were anchored at Punta Mita.

The worst conditions of all are moonless nights when there are background lights — as was the case the night of the Perdock collision. The biggest problem with background lights on moonless nights is that you have no depth perception, making it all but impossible to know if the light you're looking at is 100 feet or 1,000 yards away. And Perdock's stated concept of avoiding boats by looking for their silhouettes against background lights is sheer lunacy.

For everyone headed south to Mexico this season, try hard to reach your anchorage or harbor while it's still light. If you must enter in the dark, proceed very slowly. We've entered the harbor at Santa Barbara countless times, but on a recent dark night, we felt that anything over two knots was still too fast to safely pick out the channel markers from the background lights reflected on the water.

↑↓ "PEOPLE WANT TO HELP SO SUCK IT UP!"

The Gold Country YC celebrated Bismarck Dinius' victory after three long years of his having to fight charges that he was responsible for the death of Lynn Thornton in that terrible boating accident on Clear Lake. Our little yacht club here in the foothills of Nevada County on Scott's Flat Lake has been behind Dinius, who is one of our own, for what's been a long and hard road for him. He was welcomed to cheers of joy as he arrived at our most recent general meeting. We, along with much of the sailing community around the country, had been praying for him all during the ordeal. And we haven't forgotten about Lynn Thornton. Our prayers are with her family



**CELEBRATING OUR
25th YEAR OF SERVICE**

SAN FRANCISCO BOAT WORKS

835 Terry A. François St., San Francisco, CA 94158
(415) 626-3275 Fax (415) 626-9172

www.sfboatworks.com info@sfboatworks.net

Be our guest for lunch at the historic Ramp Restaurant*

**Some restrictions apply*



for Savings!

**TIME MARCHES ON...
But boating weather
is still perfect in
the Bay Area!**

**Mention this ad for a
"Fall Is Back"
Discount**



**Stainless Steel Boating
Hardware at
AFFORDABLE PRICES!**

Now a stocking distributor of the
HYDRO BUBBLE ANCHOR



**Wheels
that work!**

**Flip-It Wheels
Perfect for Baja Ha-Ha**

Visit Our Website for Unbelievable Prices!

- SS Anchors from 4 to 105 lbs.
- SS Shackles, Sailboat Hardware and Deck Fittings
- SS Anchor Chain
- Dinghy Wheels

DaNard Marine Products
Oxnard, CA
(805) 983-8285
www.DaNardMarine.com

Marine Art
Margaret W Fago



Starting in October 2009 see me at the
Point Richmond Art Collective
121 Park Place, Point Richmond, CA

www.margaretfago.com

mwfago@earthlink.net

BLUE WATER YACHT INSURANCE

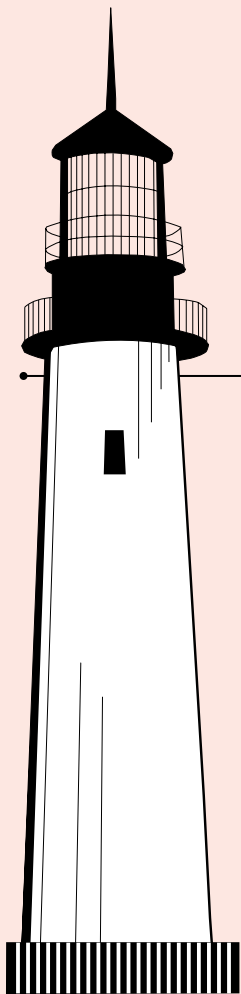

Blue Water Yacht Insurance covers more active cruising boats than any other marine agency in the Western Hemisphere, and is the leading innovator of insurance products for the offshore sailor.

Our Insurance Programs Provide:

- Crew of two anywhere
- Worldwide Navigation
- Hawaii
- Caribbean
- South Pacific
- Mexico
- Charter Boats
- Multihulls
- Liveaboards
- Racing Boats

Quality Rated Insurance Companies

Boats aged 1 to 40 years • "Agreed Value"
"All Risks" • "New for Old" replacement partial losses
Hulls valued \$50,000 to \$2,500,000

Worldwide Health Insurance

International and USA health insurance plans at affordable prices.



BLUE WATER
INSURANCE
JUPITER, FLORIDA • USA

Call Toll Free
(866) 463-0167
Fax: (866) 795-3707
sales@bluewaterinsurance.com

Quote requests
Visit our website

www.bluewaterinsurance.com

LETTERS

as well. We can't thank *Latitude* enough for your coverage of the story and support of Bismarck. We're sure it helped the outcome of this unbelievable injustice. Thank you! Thank you!



GOLD COUNTRY YC

The Gold Country YC, aka The Bismarck Dinius Defense & Fan Club.

Thank you!
Your readers might be interested in the following letter that Bismarck sent to us after the meeting:

"I'm so glad that I made it up to the yacht club for the meeting. It was won-

derful to see everyone and be able to say thank you. The club has really embraced me, and I have been moved by everyone's genuine kindness. It was great to hear the cheers as I walked up. You made me feel like family, and you were all there to lift me up when I was down. I am truly grateful.

"I owe a few special thank yous. One goes out to Bruce. He is the one who contacted *Latitude* and really got the story going. He also took me aside one day and really encouraged me to open a defense fund. He said, 'Look, there are a lot of people who want to help you and donate to your cause. People keep asking me where they can send money. Suck up your pride and open a fund. Everyone needs a hand now and then, and people want to help you. You are a wonderful human being.' That was some of the best advice I have ever received. The fund has helped immensely."

Joe Day, Commodore
Gold Country YC
Daydreams, Pearson 385
Mental Floss, Catalina 22

Joe — We're so happy for Bismarck. On the other hand, we're still livid that it took a jury to finally bring some sense to the case, and that Perdock still hasn't been charged.

By the way, Bismarck is a little off on how Latitude got involved. One morning about a year after Thornton was killed, the publisher rolled over in bed and said to Doña de Mallorca, "We wonder whatever happened in the case of the woman who got killed in the boating accident on Clear Lake?" So when we got into the office, we asked Editor LaDonna Bubak to call the D.A. in Lake County to find out what was going on. It turned out that he'd just then made the foolish decision to charge Dinius rather than Perdock for the wrongful death of Thornton.

↑↓THE FLINTSTONES DAGGERBOARD SYSTEM

In the 'Triangulation' photo aboard *Profligate* in last month's *Sightings* section, I noticed that your cat's port daggerboard has what appears to be a hole in it a few inches down from the top. As I am building a Schionning Wilderness 1100, which is the little cousin to Jim and Kent Milski's Berkeley-based *Sea Level*, I have been pondering daggerboard system designs. Do you secure your boards in various positions via an athwartship pin through the board near deck level? I like the simplicity of that concept and was thinking of using it on my cat.

Brian Timpe
Seattle

Yacht owners can trust **PACIFIC CREST CANVAS*** for the best in design, service and quality.

• **Offshore Dodger™**

Welded aft handrail
Bolt-on side handrails
Lexan windshields

• **Baja Awning™**

Lightweight and waterproof
Durable and easy to launch
Multiple side screen configurations

Our Sailor Stimulus: Still the Highest Quality Products at the Best Prices



Pete Fuller, a professional Bay Pilot with good taste in both fine sailing yachts and offshore dodgers!

• **Coastal Dodger™**

Affordable designs
Same high quality materials
Same superior workmanship

• **Cruiser's Awning™**

Easy setup off your dodger
Flies with no bulky frame
Comes with shade screens

Open Monday-Friday 8:00-4:00
Saturday by appointment
(510) 521-1938



2021 Alaska Packer Place
Alameda, CA 94501
Grand Marina

**Former owner at Pacific Coast Canvas*



BLUESTORM



Prepare for the unexpected



Bluestorm Inflatable PFDs provide the ultimate in style, safety and value.

- Three sailing models with built-in harness
- Manual, fully automatic, or convertible inflation
- USCG approved

Bluestorm
P.O. Box 210
Plympton, MA USA
(877) 688-5657
www.bluestorm.us



Original Boat and Harbor Protection
American Made Since 1956

****Mention this ad to receive a 10% discount****



**Ball Fenders
Corner Fenders
Side Fenders
Tear Drop Fenders
Lap Side Fenders
Marker Buoys
Boat Fenders
Owls**

Neumann & Bennetts
419 Broad St.
Klamath Falls, Or. 97601
1-800-779-0442
www.Plasti-Duk.com



License #0E32738

TWIN RIVERS MARINE INSURANCE

AGENCY, INC.

"Your Boat Insurance Specialists"

7 Marina Plaza • Antioch, CA 94509

At The Antioch Marina

Need Mexico Insurance? Call Today!

- Mexican Liability • Broad Navigational Areas
- Shop Your Renewal & \$ave ~ Flexible Survey Requirements
- Liveboards • Agreed Value Policies



Get a quick quote today at:
www.BoatInsuranceOnly.com
 (800) 259-5701

Insurance made simple, affordable and effective.

Representing...

 Global Marine

 CHUBB
PERSONAL
INSURANCE

 INTERNATIONAL
MARINE
UNDERWRITERS

 TRAVELERS
Insurance Agency

 MARKEL INSURANCE COMPANY

 ace seguros
 ace recreational
marine insurance

 FOREMOST
INSURANCE GROUP

 AMERICAN
MODERN
INSURANCE GROUP

 Safeco Insurance

LLOYD'S

Years of unbeatable experience to
match your needs to the right product.

Worldwide Coverage

West Coast ◻ Mexico ◻ East Coast
Caribbean ◻ Pacific ◻ Atlantic

LETTERS

Brian — For reasons we prefer not to go into, we have what we call a 'Flintstones System', so named because it's about as sophisticated as everything was on that cartoon show. For better or worse, our daggerboards are limited to two positions: all the way up or all the way down. As it turns out, the only time we have the boards down is when we are beating or close reaching.

Our daggerboards are 14 feet long. Even though they are heavy, they have a certain amount of positive buoyancy. If not secured in the up or down position, the top nine feet float in the daggerboard case. When we want a board in the up position, it gets held in place — as you suggested — by a 1.5-inch dowel that runs athwartships at the deck level. It sounds stupid and looks a little silly, but it's worked out well. The dowel broke the only time we hit bottom with a daggerboard, allowing the daggerboard to pop up and avoid any damage beyond a scratch.

If we want to put the board in the down position, we have to lift it slightly to be able to slip the dowel pin out. It's a one-person job when we use the electric halyard winch. If we're in a hurry, two guys muscle the board one quarter inch up, and another member of the crew pulls the pin. Then we step on the top of the board to counteract the positive buoyancy and make it flush with the deck. At that point a person in the head pushes the pin through a hole in daggerboard case and the daggerboard, which secures it in the down position. To raise the board, someone has to step on it just right in order for another someone in the head to be able to pull the pin out. Once the board pops free, it has to be lifted to the full-up position, either with a halyard or by hand.

To date we've been happy with our ultra KISS system. Good luck with your cat and daggerboard system design.

↑↓ JOLLY ROGER IS WORRIED ABOUT PIRATES

I'll be sailing from Guaymas, Mexico, to the Panama Canal in November of this year, and expect to take two months to reach the Canal, including a week or so in Costa Rica. I have a few questions about my route. First, can you suggest interesting ports that I should stop at? I have all the large ones plotted, but you may know a few that are small, inexpensive and interesting. Second, are there places that I should avoid because of known piracy or other factors such as very high mooring or fuel prices?

I'm then going to sail south from the Canal, and was told to avoid Colombia. What information do you have on ports in Venezuela and the Lesser Antilles? And last, I will need to put the boat on the hard out of the hurricane zone, and therefore need to know of a place south of Venezuela.

By the way, I did the Ha-Ha last year and had a really fun experience.

Roger Behnken
Jolly Roger, Bombay 44
Berkeley

Roger — Thanks for the kind words about the Ha-Ha. As for places to stop between Guaymas and the Canal, they are all pretty well-known, and as you near each place you'll be getting the most current info and recommendations from fellow cruisers. Puerto Madero, Mexico, is a place where some cruisers have had trouble with officials, so keep your ears open once you get in that area. Lots of cruisers rush past the islands off the north coast of Panama, but those who stop seem to really enjoy them. But you may be in too much of a hurry to do that. Berthing and moorings in Third World countries tend to be at least as expensive as in the States, so if you're on a budget, ask around for the best places to anchor. There are plenty. As



VALLEJO MARINA

Gateway to the Bay & Delta



48-ft. BERTHS NOW AVAILABLE

- Ample Guest Dock
- Full Service Boat Yard and Chandlery
- 2 Restaurants for Breakfast, Lunch, Cocktails and Dinner
- Covered and Open Berths
- One hour from Sacramento
- Only three hours from Reno
- Easy access to San Francisco Bay and the Delta

FILL 'ER UP ON YOUR WAY TO THE DELTA!

SPECIAL FUEL PROMOTION

- Buy \$100 worth of fuel*
- Receive a coupon for \$10 for future use

*Call for low daily rates. Conditions apply. Special ends 10/31/09.



(707) 648-4370

Fax 707-648-4660

42 Harbor Way

Vallejo, CA 94590

www.ci.vallejo.ca.us

PortVisor™

Shield opening ports from rain

- Keep ports open in the rain
- Air out cabin and head
- Maintain visibility
- Increase boat's comfort
- Install easily, without tools
- Enjoy life aboard more often



Many sizes for aluminum, bronze, stainless, and plastic portholes. Made from clear UV-resistant Lexan with bronze tint.

www. **Seaworthy Goods** .com
Smart Stuff. Smart Boats.

(941) 448-9173

SEA FROST®



COOL IT YOURSELF!

Refrigeration has never been easier. Sea Frost's compact and powerful, 12-volt BD refrigeration conversion kit comes pre-charged and ready for owner installation.

Sea Frost... Quality at an affordable price!

Local Dealers:

Anderson Refrigeration Co. • Alameda, CA
(510) 521-3111

Poole Refrigeration Service • Alameda, CA
(510) 523-3495

www.seafrost.com

MARINE EMPORIUM

At The Bridge

since 1968

Yacht Sales



35' Harbormaster Houseboat, 1980
\$33,000



40' Kayot Pontoon Houseboat, 1973
\$16,900



30' Island Gypsy, 1982
Fly Bridge Trawler. \$59,500



31' Flybridge Silverton, 1978
\$12,000



40' Buchan Sloop, 1958
\$19,500



26' Columbia Sloop, 1970
\$5,900

- **FULL SERVICE BOAT YARD AND DRY DOCK:**
Haulouts up to 60 tons, expert fiberglass and metal work, bottom paint, etc.
- **RUNNING GEAR and REFINISHING**
- **COMPLETE MARINE CHANDLERY**
- **PARTS and SERVICE**



5993 Bethel Island Road
PO Box 520, Bethel Island, CA 94511
(925) 684-2330
www.marineemporium.com

LETTERS

long as you take the normal precautions, you shouldn't have any problems with crime.

You confuse us when you say you're going to sail south of the Canal, but then seem to suggest that you'll be doing it on your way to Venezuela and the Lesser Antilles. If you sail south of Panama, you'll pass the Pacific coast of Colombia on your way to Ecuador. The Pacific coast of Colombia is not only remote, it's largely lawless. Some cruisers were attacked there a year or so ago while anchored out, and think they only survived because their shouts attracted the attention of another cruising boat that just happened to be nearby. This is not the safest place.

If, on the other hand, you're talking about the Caribbean coast of Colombia, you shouldn't have any problems at the San Blas Islands or Cartagena. The last time we were there, the coast between the two was a no-man's land. Lots of folks in the San Blas can give you the current info. A few years ago there were a number of violent incidents against cruisers — including some Ha-Ha vets — on the coast of Colombia between Cartagena and Cabo Velo. You should consult with the big cruising community at Cartagena before deciding whether to stop. We assume you're aware that the passage from Cartagena to Cabo Velo is frequently one of the nastiest upwind passages in the world of cruising, particularly between mid-December and June. And it's not very easy the rest of the year either, so make sure you gird up for it.

Lots of cruisers still go to Venezuela, but violent incidents have been on the rise, particularly in the eastern part of the country. There's no convenient place to put a boat on the hard for hurricane season that is south of Venezuela, so we'd recommend either a marina in the area of Puerto La Cruz, Venezuela, or at Trinidad. While Trinidad is north of Venezuela, it's still south of the hurricane zone.

No matter where you go, your greatest security risks will be while you're ashore. Nonetheless, we suggest that you always be vigilant along the coasts of Colombia and Venezuela.

↑↓ WE'RE PRETTY SURE WE AGREE WITH YOU

In a recent *Lectronic* there was a piece about the Delta, with a photo of boats anchored in Middle Slough. The far boat looked like a Searunner trimaran, which is the kind of boat I own.

Having established a connection, I know you've run many Delta articles in the past, but here is how it works now. I go to maps.google.com and drill down to see what I want to see. The point is, I want to orient myself on a map/chart, so I look for 'waypoints' — places that were mentioned in the article — on Google Maps. That's the way it works these days, not just for me, but for any internet-savvy person.

Name Withheld By Request
Bay Area

N.W.B.R. — We're a little bit confused about what you're recommending, but we're enormous fans of Google Maps and Google Earth. In fact, some of our favorite 'sailing porn' is using Google Earth to revisit anchorages we've been to around the world.

Ever since Google Earth came out, we've recommended that cruisers heading to Mexico — and other places — print out a color aerial photo of each anchorage they might want to visit. Such aerial views are great safety aids in that they correct inaccurate 'chartlets' found in many cruising guides, and give a great overall idea of the lay of the land and possible dangers. So, of course, mariners should use Google Earth to help plan and enjoy their sailing adventures in the Delta and elsewhere.

Own a dock on San Francisco Bay! Perfect Location - Great Investment

Just dredged
40' monthly rent \$342

EMERY COVE
YACHT HARBOR

BUY A SLIP – Save money & earn equity! Save 1/3 of your rental cost. Enjoy big tax savings as a slip owner. Emery Cove Yacht Harbor is the only marina on the Bay with FEE SIMPLE (not a grounds lease) dockminium ownership.
OR RENT A SLIP – 35-60' slips, rates from \$8.55 to \$9.55.
MARINA GUARD® – cutting edge electrical ground fault monitoring system.

Michael Wiest Yacht Sales
& Emeryville Yacht Club
on premises



CALL FOR A MARKETING PACKAGE • 510-428-0505
3300 Powell Street, Emeryville, CA 94608 • www.emerycove.com • Email: info@emerycove.com

HIRSCHFELD YACHT LLC

Offering the *best value* in the Bay Area for:
Marine Repair, Service, and Repowers

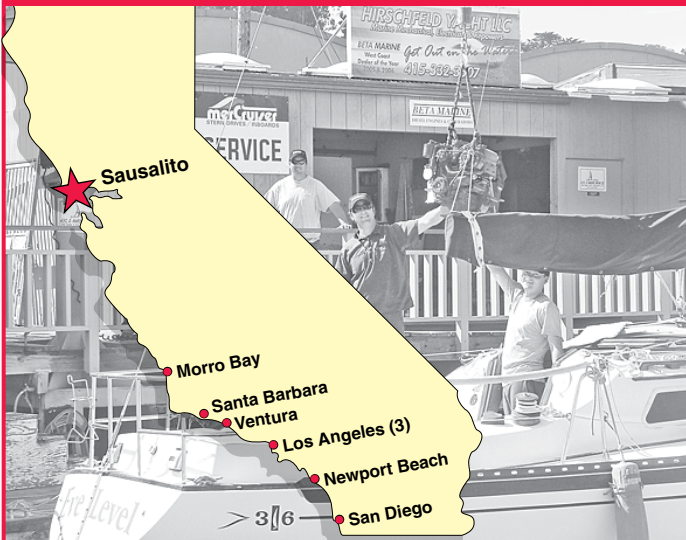

We are the exclusive distributor of
Beta Marine diesel engines and generators in California.

BETA MARINE WEST

39 Libertyship Way, Sausalito, CA 94965
www.engineerite.com • www.betamarinewest.com
(415) 332-3507

ePaint
Eco-friendly Bottom Paints

It's Easy Going Green!



EP-2000 Antifouling Paint
Perfect for California Boaters

- Copper-free
- Water-based, low VOC
- Hard, scrubbable finish
- Ideal for all rigid hull types
- Self-priming on bare aluminum
- Patented photoactive technology

800-258-5998 www.epaint.com

North times seven.

When performance counts the choice is clear.
Call your nearest North Sails representative.

Sausalito

415-339-3000

San Rafael-Sail Care

415-453-2142

Channel Islands

805-984-8100

Marina Del Rey

310-827-8888

Long Beach

562-795-5488

Costa Mesa-Sail Care

949-645-4660

San Diego

619-224-2424



www.northsails.com

LETTERS

↑↓ YOU, TOO, CAN HAVE A 65-INCHER

My wife Mary and I are currently moored at Avalon, and have just finished watching a movie on the 65-inch screen inside our 40-ft boat. It sounds crazy, but we'd like to let everyone know how easy it is to have an actual theater in one's boat.

Mary and I rented our north Orange County home out in October of last year and moved aboard our Island Packet



COURTESY ISLAND TIME

I scream, you scream, we all scream for a 65-inch screen — like the one rolled up here in the main salon of 'Island Time'.

40 in Los Angeles Harbor. It's something that we'd been looking forward for many years, and the time was right. There were only a couple of things that we missed from our shore-based life: the hot tub and

the big screen TV. I couldn't really do much about the hot tub, but I figured we'd at least work on the TV. When I spoke with Mary about upgrading our tiny 15-inch flat panel television for something larger — say 20-22 inches — she asked me, "Why don't you look at a projector?" Man, I love it when she says things like that! So, I embarked on the research mission from hell to find a projector we could use. *Voila!* I discovered the digital DVD projector system called Movietime from Optoma. Movietime is an "all in one" digital projector that has built-in speakers and a top-loading DVD player. It is a 'short throw' projector that is really meant to plop down on a coffee table, plug in, and project on a wall or screen. This thing can easily project a 100-inch or better high-quality picture on a wall.

Being thrifty, I found a used one on *Amazon.com* for about half the \$600-900 retail price. I placed the unit on the shelf above my starboard settee, and initially used a white sheet



COURTESY ISLAND TIME

The Optoma Movietime may look weird but it works great.

hung on the port side just to get an idea of how big a screen I would need. I found the projected image to be 64-65 inches wide, and about 35 inches high. After a quick shop around on the internet, I was able to locate a couple of screen dealers with really reasonable prices. I ordered a manual 50-x 67-inch screen for less than \$100. I mounted the screen with quick-release hooks to two padeyes located above and to either side of the port settee. With the screen up, you have to look twice to even notice that it is there, because the white housing blends in with the background. Thanks to the quick release hooks, I can take it down in about five seconds and stow it in the aft stateroom.

WITHOUT PASSION, IT'S JUST WIND AND WATER.



415.381.4773
safepassagesailing.com

SAFE PASSAGE SAILING, LLC
Your next adventure.

The Heineken Regatta, St. Maarten
Antigua Sailing Week, Antigua
JP Morgan Round the Island Race, Cowes

Photo by James Robinson Taylor

CAPTAIN'S COURSES

Classroom classes in 15 cities and now Online!



Captain's License

U.S. Coast Guard
approved courses and testing.
Approved for Veterans.

Classroom or Online?

We believe the interactions and structure of a classroom provide the best training experience. Even so, for some students attending a scheduled course just isn't possible. There is a solution.

We now offer courses Online!

Whether you choose traditional classroom or the new online courses, rest assured we'll hold to the same high standards we've maintained for over thirty years.

Our next San Rafael class begins Oct. 19th

Check our website schedule for other locations and courses.

MARITIME INSTITUTE

To enroll or for more info: www.MaritimeInstitute.com
or **CALL TOLL FREE 888-262-8020**

Harbor 25



See the
Harbor 20 and 25 at
the Annapolis Boat
Show

Enjoy Sailing in Style and Comfort

The Harbor 25 is a stunning NEW design with classic looks, a roomy cockpit, a beautiful teak interior, and an inboard engine.

W.D. Schock CORP.

Est. 1946

Boat Builders - 23125 Temescal Canyon Rd., Corona, CA 92883 · (951) 277-3377 · Fax (951) 277-4104
Email schock@wdschock.com · Website www.wdschock.com



C. SHERMAN JOHNSON CO. INC.
Johnson
Marine Hardware

KEEPING YOU CONNECTED FOR 50 YEARS!

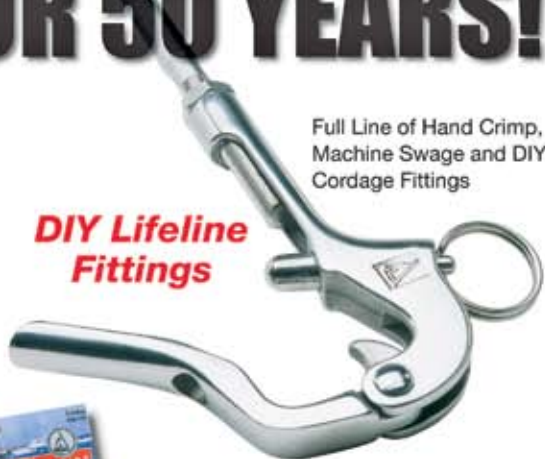

Full Line of Hand Crimp,
Machine Swage and DIY
Cordage Fittings

**DIY Lifeline
Fittings**



**Unique
Accessories**

Grab 'n Go™ Hook

**Rigging
Hardware**



Calibrated
Turnbuckle



C. Sherman Johnson Co., Inc.
East Haddam, CT
1-860-873-8697

www.csjohnson.com

LETTERS

You have got to see this thing to believe it! We now do the Netflix thing, and watch movies nearly every night. Our 'boat theater' has blown away just about everyone who has visited us — it's really funny. From sports to movies to concerts, the viewing is just great.

As I kept the little flat screen mounted on the starboard bulkhead for 'morning coffee' television, I had to buy a digital converter. But I found that I was able to hook a pair of cables from the back of the converter to the input at the rear of our Movietime, allowing us to project the digital broadcasts with the projector!

Mike & Mary Kelley
Island Time, Island Packet 40
Los Angeles Harbor

Readers — Please, let's not have any smart ass remarks about Mary being a 'screen size queen'. What are the Kelleys'



COURTESY ISLAND TIME

'Captain Ron', the secular patron saint of sailors, as seen on 'Island Time's big screen.

favorite movies? "Captain Ron is probably our favorite, so it's what we usually put on when we demonstrate the set-up to friends,"

says Mike. His other favorites are Black Hawk Down and Meat Loaf Live With the Melbourne Symphony Orchestra. Mary's favorites are Sex in the City, True Blood and Metallica S&M.

↑ **DON'T BOTHER US, WE'RE BUSY BEING FRIENDLY**

As I was scanning the July *Changes*, the reference on page 135 to The Nature Conservancy jumped out at me — because I'm now working for that organization in Nevada.

The caption on the photo spread that said TNC "kicked out" cruisers struck me as making us seem, well, unfriendly. But that's something that the TNC is definitely not. In fact, TNC is so successful at finding "solutions that benefit people and nature" because we are non-confrontational and we work with everyone to protect critical habitat for biodiversity. And as far as there being "all kinds of rules . . .", one of our biggest challenges is how to allow people to enjoy fragile habitats without unduly impacting them. In fact, I was impressed that the crew of *Cocokai* got to stay at Palmyra for four whole days! I guess that doesn't seem very long to bluewater cruisers.

To learn more about why Palmyra is so special, go to www.nature.org/wherewework/asiapacific/palmyra. There readers will learn that if TNC had not purchased the Palmyra Atoll in '00, it might be home to a nuclear waste dump or a casino by now.

Anne Thomas
Raven, CM1200
Gardnerville, Nevada

Anne — We don't like to disagree with you, but if The Nature Conservancy came across as being "unfriendly" for kicking the Cocokai crew out after "four whole days," we think it's because The Nature Conservancy was unfriendly. If they owned the only



**ESSEX
CREDIT**

NEW - USED - REFINANCE

Boat Loans Made Easy®



Let our 27 years of experience go to work for you!

Richard Tressler
866-377-3948 ext. 47008

www.essexcredit.com

EQUAL CREDIT OPPORTUNITY LENDER

Loan Amounts from \$15,000 Instant Loan Approvals*
Zero Down Program* 90 Days to First Payment*

*(Subject to Loan Program Guidelines and Credit Approval)

Reference Code =MAR931

BOATSMITH, INC.

BOATBUILDING ~ MARINE CARPENTRY



Specializing in composite wood construction

Authorized builders for James Wharram Designs and Reuel Parker. We can build to any design you desire.

561.744.0855 | 561.632.2628

www.boatsmithfl.com

Jupiter, Florida

FALL SPECIALS on LIFERAFTS/TENDERS FOR CRUISERS

through 10/31/09



The most essential items for cruisers:
✓ LIFERAFT ✓ EPIRB ✓ DINGHY

SAL'S
INFLATABLE
SERVICES, INC.

PHONE (510) 522-1824

FAX (510) 522-1064

1914 Stanford St., Alameda 94501
salsinflatables@sbcglobal.net
www.salsinflatableservices.com

**SALES • SERVICE
RENTAL • REPAIR**

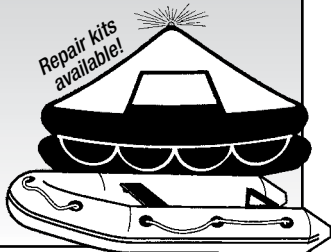

**BUY
ONE**

**GET
ONE**

**1/2
OFF**



**Visit us before November 30, 2009
to receive a second winch at half price.**

Select models only. Sizes 32-53: chrome, aluminum,
manual, electric, self-tailing, plain-top, Quattro



2822 Canon St., San Diego, CA 92106
P: (619) 225-9411, F: (619) 225-9414
(800) 532-3831
Sales@SailingSupply.com
www.SailingSupply.com

HARKEN®

LETTERS

water hole in a massive desert, we shudder to think how few drops they would allot each parched traveller who came by.

Maybe four whole days would seem like a long time to the billionaires who are the core supporters of The Nature Conservancy, and who often travel to Nature Conservancy sites by private jet or megayacht. But it's not to sailors to who make big sacrifices to arrive at such remote places in such an eco-friendly fashion. As anyone who has crossed an ocean can attest, it takes at least 24 hours to recover from an ocean passage and 24 hours



COURTESY COCOKAI

How could The Nature Conservancy staff at Palmyra give sweet little Coco the boot after just four days?

to prepare for the next leg — which would have left the Cocokai crew with a pitifully short two days at Palmyra to relax and have a peek around. Geez, thanks a lot.

As we recall, Cocokai burned only 15 gallons of diesel on their three-week, 3,000-mile trip from the Galapagos to the Marquesas. That's about one quarter of what self-proclaimed ocean-loving mini-megayacht owners burn using one generator for one day while tied to the dock. And a fraction of what they use in a single hour while underway. So we think The Nature Conservancy should not only welcome visiting sailors with a week's stay at Palmyra, but should also honor them with an exhibit celebrating what a small footprint they've left in getting there.

Yes, we understand the need to protect critical habitats and for such places not to be overrun by crowds, but we don't think respectful cruisers staying a week would pose any danger to Palmyra. As for the contention that remote Palmyra might have become a casino had the Conservancy not bought it, come on — that was about as much in the cards as our becoming the next black President of the United States.

⇕ **HE SEEMS LIKE SUCH A NICE MAN**

My wife and I have just spent the past two months in the river/estuary of Playa del Sol, El Salvador, aboard our boat *Freedom*. It's a beautiful, peaceful place to pass the days, explore, do boat projects, and enjoy the cruising lifestyle. During this time, we've come to know the people and politics of the small community quite well.

The May edition of *Latitude* featured a letter titled "44 Days in an El Salvador Jail," that was written by a man named Alfred. The man painted a colorful picture of his experiences here, and described how a local man named Santos allegedly assaulted him, broke his arm, and threatened him with a pistol. As a result of the dispute, Alfred claims to have spent 44 days in an El Salvadoran jail.

Alfred writes an entertaining article, and while we must admit that we weren't around when the alleged incidents occurred, there are clearly holes in what he presented as facts. In the two months that we've spent here, we've learned that Alfred changed his story many times. For example, I read court documents that said his left arm was broken, but at a later hearing, his right arm was in a cast. Furthermore, Alfred never presented an X-ray of his broken arm, proof of the injury, or even evidence that he'd visited a doctor.

MORE SAVINGS! MORE FUN!

La Paz, Mexico Flotilla July 1-9 2010

This 8-day trip includes 6 days of sailing on luxury catamarans, plus one night hotel in La Paz.

Cost per Cabin \$2600/member or \$3000/non-member
Flight cost from San Francisco to La Paz \$675 per person

For more details, visit: www.TradewindsSailing.com, then click on Sailing Adventures.

Basic Keelboat (101) - \$595

Oct 3,4,10
Oct 4,10,11
Oct 7,8,9
Oct 10,11,12
Oct 10,11,17
Oct 11,17,18

Basic Coastal Cruising (103) - \$795

Oct 10,11,17
Oct 11,17,18
Oct 12,13,14
Oct 21,22,23
Oct 24,25,31
Oct 25,31 & Nov 1

Bareboat Chartering (104) - \$995

Oct 4,10,11
Oct 5,6,7
Oct 18,24,25

Winter Special!
Take **\$100** off any of the below courses*
or take advantage of our 3 Class Package
(101,103 & 104) at **\$1895.00**



Tradewinds Sailing School and Club

More Experience. More Time on the Water. More Fun.

2580 Spinnaker Way, Richmond, CA 94804, (510) 232-7999

DEMAND POWER? DEMAND KOHLER.



Gas Generators
from 5 kW to 20kW

Diesel Generators
From 6 kW to 500 kW

KOHLER

- All KOHLER generators have self-monitoring and self-diagnostic capabilities supplied by a unique **Advanced Digital Controller (ADC)**.
- Besides monitoring 13 diagnostic conditions and being easy to use, the ADC delivers cleaner, more precise voltage and frequency regulation, provides better fuel efficiency, and operates cleaner for the environment.
- **KOHLER Low CO gasoline generators** meets both CARB and EPA standards for CO and HC + NOx emission levels.
- Every KOHLER Generator comes with a comprehensive warranty supported by a network of more than 500 marine dealers and distributors around the globe.

NOW SERVING THE EAST BAY AREA

BOATSWAIN'S LOCKER®

866-908-2676

• 2394-A Mariner Square Dr., Alameda CA

• 931 W. 18th St., Costa Mesa CA

• www.boatswainslocker.com



Wright Way designs

Custom Yacht Interiors

Recover

Restore

Revive

PROFESSIONAL DESIGN
SERVICES INCLUDE CUSTOM
carpeting
cushions
designer fabrics
draperies
linens
upholstery



WINTER SPECIAL
20% OFF

Foam & Fabric
Good thru 11/30/09

Deborah Wright
510.908.3939

Make your dreams come true...

2900 Main Street #67, Alameda, CA 94501
www.wrightwaydesigns.com

LETTERS

Alfred sued Santos for \$15,000 to settle the case, far more than any medical care or legal fees would justify. The suit that had been dragging on well over a year just came to a close in mid-July, and Santos was given two options: 1) Sign a confession and pay Alfred \$3,000 U.S., or 2) go to jail for six years, with his mother being incarcerated, too.

There was no jury or any semblance of a legal process in the case. It was a confess-and-pay-or-go-directly-to-jail choice. It's a shame what an American cruiser might do to replenish his cruising funds.

Santos signed the confession, and will have to struggle greatly to make the payments to Alfred over the next six months. It's a real tragedy, because the Santos we know is an honest, kind, humble, hard-working family man, who only wants only to provide for his wife and young son.

Santos provides moorings and marine services to cruisers. We got exceptional service from him at a very reasonable price. We've spent enough significant time with Santos and his family to know that the charges against him are false and that he's been wronged by this whole episode. Santos is a good man, and we support him.

Robert & Keli Parker
Freedom, Downeaster 38
San Pedro, CA

Robert and Keli — To put a little perspective on things, it should be noted that while cruisers have had few problems in El Salvador, the country has one of the highest crime and murder rates in the Americas. It's a country where gangs and extortion are rampant. According to National Public Radio, almost all small businesses in the cities have to pay daily la renta to gangs. Some bus drivers even say they get hit up more than once per route. So we're not talking New Zealand or Switzerland.

Like you, we weren't on the scene during the Santos-Alfred troubles. As such, we think it's impossible to know for sure who is guilty of what. But our two-letter response to your claim that you've gotten to know Santos well enough to know he has been wronged is: O.J. The prisons are full of charming people who have committed heinous crimes that their friends and relatives can't fathom.

We're particularly puzzled by your assertion that Alfred somehow got in a dispute with Santos "to replenish his cruising kitty." His case might be the one-in-a-million exception to the rule, but generally speaking, foreign visitors — particularly those on "yachts" in extremely poor countries — get the short end of the stick from local authorities and judges. After all, what kind of leverage could Alfred, a budget cruiser, possibly have had against a citizen of El Salvador in El Salvador? Particularly after Alfred had already spent 44 days in a Salvadoran jail?

We're never going to know for sure, but if we had to give odds, it would be that Santos and his mama might not be as angelic as you think. And for what it's worth, remember that Santos and Alfred started out as great friends, too.

In a typical month, we receive a tremendous volume of letters. So if yours hasn't appeared, don't give up hope.

We welcome all letters that are of interest to sailors. Please include your name, your boat's name, hailing port, and, if possible, a way to contact you for clarifications.

By far the best way to send letters is to email them to richard@latitude38.com. You can also mail them to 15 Locust, Mill Valley, CA, 94941, or fax them to (415) 383-5816.

**SAIL TO
OUR NEW
MARINA**

**NEW SLIPS
COMING SOON**
Limited Availability
**RESERVE
TODAY!**

**Great Long-Term
Lease Deals**
• **Up to 15 Years** •
Summer 2009

- electricity
- deli facilities
- fire fighting system
- waste disposal
- fuel dock
- 24/7 security
- wi-fi

Official Sponsor
**2009
BAJA
HA-HA**

LAT. 20°41' 22"N • LONG 105°17' 28"W



WWW.MARINANUEVOVALLARTA.COM

MONITORING VHF 16

PH: 52 (322) 29 77 000

HARBOR MASTER: JUAN S. ESTRADA

JUAN@MARINANUEVOVALLARTA.COM



Beautiful 20 acre greenbelt park in the Heart of the Delta

- Up to 30' no power/inside tie @ \$4.50 per foot
- 30'- 50' berths @ \$5.50 per foot
- Home of Andreas Cove Yacht Club

Located on Seven Mile Slough, just off the San Joaquin River

1550 W. Twitchell Island Road • Isleton, CA 95641
916.777.6055 • www.owlharbor.com

KISSINGER CANVAS

Marine Canvas & Interiors
STEVEN KISSINGER
(925) 825-6734
Covering the Entire Bay Area



- Biminis
- Boat Covers
- Cushions
- Sail Covers
- Headliners
- Awnings

DODGERS

Side handrails and window covers included.

OPTIONS

Aft handrail, dodger cover, sailing bimini.

Free Estimates and Delivery



FOR WORLD-CLASS STEINER BINOCULARS:

Start Here.

Steiner Commander V delivers 96% peak light transmission for unparalleled performance at night and in low-light. The brightest binoculars made, they're waterproof, shock resistant and come with a 30-year warranty. Call or click for a free catalog or to sign up for our monthly Landfall Report e-mail. Shop online anytime.

 **Landfall**
WHERE SAFE VOYAGES BEGIN

800-941-2219 | landfallnav.com

SAFETY | NAVIGATION | REFERENCE | WEAR

©2009 Landfall Navigation. All rights reserved.



**West Marine
Rigging Service**



Rig Your Boat for Cruising!

Complete Rigging Packages

Standing Rigging • Running Rigging • Ground Tackle

POWERLITE
RIGGING

FSE ROBLINE
MARINE RIGGING SPECIALISTS



NEW ENGLAND ROPES

RONSTAN

SAMSON

Johnson
Marine Hardware

HARKEN

SCHAEFER
MARINE

Hayn Marine

LEWMAR

FORESPAR

facnor
FUELING SYSTEMS

Contact us for all of your Rigging Needs!

888-447-RIGG

or visit our Onsite Rigging Locations in:

Alameda, CA

730 Buena Vista Ave.
(510) 521-4865

San Diego, CA

1250 Rosecrans St.
(619) 255-8844

Seattle, WA

1275 Westlake Ave. N
(206) 926-0356

Annapolis, MD

113 Hillsmere Dr.
(410) 268-0129

Rock Hill, SC

860 Marine Dr.
(803) 909-6280

Fl. Lauderdale, FL

2300 S. Federal Hwy.
(954) 527-5540

LOOSE LIPS

Driving taxpayers to drink cheap rum.

The following are first three paragraphs of a story by Tom Hamburger and Peter Wallsten that appeared in the August 2 *Los Angeles Times*.



While the connection between sailing and rum is somewhat tenuous, we thought the story was so outrageous, but so typical, that we couldn't resist.

"Yo ho ho and a bottle of rum.

"With little fanfare, a deal is moving forward to provide billions of tax dollars and tax breaks to an unlikely beneficiary — the giant British liquor producer that makes Captain Morgan rum.

"Under the agreement, Diageo in London will receive tax credits and other benefits worth \$2.7 billion over 30 years, including the \$165 million cost of

Once a pirate, always a pirate. More than 300 years after he plundered the Caribbean, Captain Henry Morgan is back to his looting ways, this time here in the good ol' U.S. of A.

building a state-of-the-art distillery on the island of St. Croix in the Virgin Islands, a U.S territory." So ends the *Times* excerpt.

A couple of interesting facts:

- Diageo is the largest distilled spirits maker in the world.
- The \$2.7 billion that Diageo will receive in benefits can also be expressed as \$2,700 million.

- The agreement will result in the creation of 40 to 70 jobs in St. Croix — but will also result in the loss of up to 300 jobs in Puerto Rico.

- According to the article, the deal has attracted "little opposition in Congress or elsewhere," except for a few representatives of Puerto Rican interests.

- Charles Rangel (D-N.Y.), chairman of the House Ways and Means Committee — which means he oversees tax policy and therefore has the "highest perch in the House" — cited his long-time support of the rum tax, and refuses to intervene in the massive giveaway.

- Also in the September 2 *L.A. Times*, there was an article reporting that the same Charles Rangel failed to report \$600,000 in income, is delinquent on taxes for two parcels in New Jersey, failed to report the sale of a \$1.3 million brownstone, and is illegally occupying four rent-controlled units in New York City. He'd previously admitted to have paid no taxes on \$75,000 worth of income on a condo in the Dominican Republic.

- If you're a taxpayer, you shouldn't be sailing and drinking rum — especially Captain Morgan rum — at the same time. But given the way the government pisses away taxpayer resources, we'd sort of understand if you did.

Can you hear me now?

Visitors to the San Francisco Maritime National Historical Park can now use their cell phones for a free audio tour of the park's features. With 28 topics ranging from 'Danger and Adventure on the High Seas' to 'Swimmers in San Francisco Bay', visitors can pick and choose which episodes to listen to. If you don't like surprises, you can even listen to the entire tour from the comfort of your salon — go to www.nps.gov/safri/planyourvisit/cellphoneaudiotours.htm for the list of topics and their corresponding tour number, then call (415) 294-6754.

McDERMOTT COSTA

insurance brokers - est. 1938

Commercial Operations

- COMMERCIAL POLICIES
Marinas, Yards,
Yacht Clubs,
Brokers,
Shipwrights



Pleasure Yachting

- YACHT & BOAT POLICIES
Offshore, Coastal,
Inland and
Liveaboards



Lic. #OB21939

Bill Fowler

McDERMOTT COSTA INSURANCE
(925) 606-6606 Fax (510) 357-3230
bfowler@mcdermottcosta.com



Advanced LED Navigation Lighting



Super Bright
Waterproof
Multiple Color Configurations
Excellent Viewing Angles
Lifetime Warranty

Available at:  SVENDSEN'S MARINE

Call or visit our website to learn more about our quality lighting products.

www.LunaseaLighting.com
1.800.272.0170

RoHS compliant  FE CE



ALAMEDA'S FINEST SLIPS AVAILABLE AT*



*Join our wait list. Prime slips do become available. Register on our free wait list to save your spot now!

WELCOME!

*Fortman Marina welcomes
David Lee and
Cruising World Pacific
to our onsite brokerage office.*

(510) 764-1734

www.fabulouusyachts.com

Sheltered Alameda Location
Competitive Rates

1535 Buena Vista Ave., Alameda, California
(510) 522-9080

For directions and rates go to:
www.fortman.com

how young is too young?

It's funny how a world record can lie dormant for years, then suddenly challengers seem to appear from all quarters. That's what's been going on lately in the realm of teenage circumnavigating. In August, we brought you news of 17-year-old Southern California singlehander Zac Sunderland's historic homecoming, which earned him the crown for 'youngest around' by any route. Then last month we reported on British solo sailer Mike Perham stealing Zac's thunder by completing

his lap at a younger age. But even as the young Brit arrived at England's Lizard Peninsula, younger contenders seemed to be nipping at his heels.

What's the latest? Sixteen-year-old Australian contender Jessica Watson made headlines last month, but definitely not the sort she was anticipating: During the first night of her intended 10-day shake-down cruise from Mooolaba, Australia, to Sydney, her 34-ft S&S, *Ella's Pink Lady*, smacked right into a 69,000-ton freighter in the middle of a shipping lane. The ornately painted pink hull was damaged and its mast was snapped, but Jessica, who was below at the time, was unharmed. With repairs nearly complete, she expects to restart

her shakedown cruise any day now, then set off on her nonstop, unassisted attempt, east-about via the Southern Ocean, as soon as possible.

Meanwhile, within days of Zac's arrival, his younger sister Abby, who turns 16 this month, gave credence to the rumor that she intends to attempt a solo rounding, and do so nonstop and unassisted. The family has already purchased a water-ballasted Class 40 sloop for the campaign. With plans to depart next month, she hopes to complete her trip — and set a new record — next April. We should clarify that both Zac and Mike Perham made stops and avoided Cape Horn by transiting the Panama Canal.

As if Jessica and Abby's intentions weren't controversial enough, a 13-year-old Dutch girl named Laura Dekker made headlines around the world when her solo ambitions became known. But a Dutch court has put the kibosh on her plans, at least for now.

What's Mike Perham's reaction to all these female upstarts? If he's nervous, it doesn't show. Within days of his return, which was heralded by great media fanfare, he announced a plan to join a team of Brits in reenacting Captain William Bligh's epic 4,000-mile voyage in an open whaleboat. History buffs will remember that the *Bounty* mutineers set Bligh and 18 loyalist crew members adrift with a sextant and a pocket watch, but no charts or compass. Some people apparently just need a mission.

But with Jessica and Abby's departures still imminent, debate rages on the question: "How young is too young?" In a lengthy verdict, the Dutch court ruled that such a voyage would be too challenging, both mentally and physically — and Laura had intended to go around the easy way, west-about through the tropics via the Panama and Suez Canals. On this one, we have to side with the court. Thirteen? You've gotta be kidding. Even though Laura was born on a boat and has spinach in her veins, we have to wonder: Was all this more about her father's aspirations, or his daughter's.

And what about Abby Sunderland? We don't get it. About a year ago, her parents explained that they hadn't wanted Zac to go the Southern Ocean route because it was too dangerous. Did it suddenly become less dangerous? As far as we can tell, those latitudes are becoming increasingly *more* dangerous, with loose sea ice more prevalent than ever. Bergie bits aside, though, what is it about a background of sailing in California coastal waters that would prepare a barely-16-year-old

continued on outside column of next sightings page

waiting with

California State Parks officials had promised to announce which state parks would be closed due to budget cuts by mid-September, but then said that the process was more complicated than they'd initially thought, postponing the decision. That's left state park employees wondering if theirs will be among the 100 parks on the chopping block.

While the staff at Angel Island State Park holds their collective breath for the announcement, they're focused on "providing the highest level of service



LAURA DEKKER

Laura Dekker, 13.



GIZARAARTS.COM

Abby Sunderland, 16.



bated breath

possible,” says Superintendent Dave Matthews. But in an effort to offload unused assets, the park’s 56-ft 1956 Marinet landing craft will be offered up for auction on December 9. If you’d like to take a look at it, contact Gerald O’Reilly at (415) 435-1748.

In the meantime, don’t let the beautiful fall weather go by without visiting your favorite state park while you still can — 25 Bay Area parks are vulnerable, including China Camp and Angel Island.

— *ladonna*

too young — cont’d

to singlehand a 40-footer in 50-ft waves and hurricane-force winds? And do Abby and Jessica really have the mechanical skills to repair all the systems that will inevitably break during a nonstop attempt? Don’t get us wrong, Abby seems like a lovely girl and we wish her the best of luck. We just don’t want to see her teenage fantasy morph into a horrible tragedy.

When our old friend Harry Heckel, Jr. completed the first of two solo circumnavigations at the age of 78, we thought he got a raw deal from the folks at the *Guinness Book of World Records*. They refused to acknowledge it, stating that they didn’t want to ‘encourage such behavior’. Now that the focus is on the younger end of the spectrum, we’re starting to see the wisdom in such an attitude.

— *andy*

“Can I play too?” — When this five-and-a-half-year-old heard that Abby and Laura were planning to solo circumnavigate, she started brushing up on her nav skills. “I want that record!” she was heard to snarl.



SIGHTINGS

the wrath of jimena

During the last 10 years, the waters off the Pacific Coast of Mexico and the Sea of Cortez have been roiled by 82 tropical storms (sustained winds of 34 to 63 knots) and 69 hurricanes (sustained winds in excess of 64 knots). That's a lot of big blows. As a general rule, they tend to form down by the Mexico-Guatemala border, then head northwest to their death partway to Hawaii. Unlike hurricanes in the Atlantic/Caribbean, Eastern Pacific hurricanes and tropical storms generally head away from land and population centers.

There are exceptions, however. During the summer, almost all cruising in Mexico takes place in the Sea of Cortez. Over the last 10 years, cruisers in the Sea have been threatened by five hurricanes or their tropical storm remnants: *Juliette* ('01), *Ignacio* and *Marty* ('03), *John* ('06), and *Norbert* ('08). Early last month, Hurricane (and later

continued on outside column of next sightings page

sequoia yc's

On 09/09/09, Sequoia YC hosted the 4th Annual Give Something Back fundraiser benefiting the Peninsula Youth Sailing Foundation, the Marine Science Institute, and both girls' and boys' Mariner and Sea Scout programs.

This special race was started four years ago by club member Ted Hannig, who decided he didn't want gifts on his birthday. He'd always found the boating community helpful, particularly in his own youth, so he wanted to give back instead. With help from the generous members of the Sequoia YC, this hugely successful event



PHOTOS J. INNIS KIRKLAND

hannig cup

has raised \$75,000 — \$25,000 raised this year alone.

But this is no ordinary beer can race. Instead of beating the competition around the buoys, boats compete to raise the most money. The boat generating the most donations takes possession of the Hannig Cup, and its skipper receives a special perpetual trophy *cum* time capsule.

The fundraising came at the right moment for the PYSF team aboard *L₂O* — they tore their spinnaker that night!

— kris butler



Beer Cans for a Cause — The annual Hannig Cup beer can race raised \$25,000 for junior sailing programs. The money couldn't have come at a better time for the Peninsula Youth Sailing Foundation — they tore their kite that night (upper left)! For info on sponsoring or racing in next year's Hannig Cup, contact Kris Butler at (650) 868-8862.

jimena — cont'd

Tropical Storm) *Jimena* paid a visit to Baja and the Sea of Cortez. The one-time Category 4 hurricane (winds from 114 to 135 knots) did lots of damage but surprisingly little of it was to cruising interests.

After following the curve of the coast of mainland Mexico several hundred miles offshore, *Jimena* was forecast to hit both Cabo San Lucas and La Paz, the two biggest population and boating centers in Baja. Luckily for both places, *Jimena* drifted farther to the west, leaving those two cities all but unscathed.

The eye of *Jimena*, still packing hurricane-force winds, came ashore at remote Mag Bay on the Pacific Coast, about 150 miles northwest of Cabo. The villages of San Carlos on Mag Bay, and Mateo Lopez on the inland waterway, were severely damaged, as were the mid-peninsula towns of Constitución and Insurgentes. Other coastal villages, such as Abrejos and Ascunción, were said to have been hit hard.

As *Jimena* continued on, cruisers at cruising centers to the north had reason for optimism. Not only had it lost a lot of its power over land, but it was also forecast to abruptly turn due west, which would have taken it back out over the open ocean. The thing is, you just can't trust hurricanes or hurricane forecasts. Instead of turning due west, *Jimena* headed due east, 180° off her projected course. Here's what happened in the various cruiser centers:

Puerto Escondido/Loreto — According to Dave Wallace of the Redwood City-based Amel Maramu *Air Ops*, the eye of then-Tropical Storm *Jimena* passed within 50 miles of the nearly enclosed anchorage. It blew about 55 knots for a number of hours, with a reported gust of 89 knots. Over the years, Singlar's 170 mooring balls have been criticized by some cruisers as being inadequate. Yet not a one of them failed in the storm, while a number of boats' mooring lines to the buoys did fail. The sailboat *Saltshaker* broke loose, but her skipper, aided by the crew of a motor vessel, was able to grab another buoy. The sailboat *Neka* chafed through her mooring line, and drifted into the mangroves. The Singlar staff put her back on a mooring. *Waverly's* mooring line chafed through and, like *Wanderlust* and *Spirit*, which were on their own hooks, went ashore. Out in the Waiting Room, two boats went ashore. Wallace wants to emphasize that no attended boats went ashore. However, all the boats that did were refloated by the Singlar staff and other cruisers. The 14 boats on the hard at Singlar all stayed up.

Concepción Bay — Having survived Hurricane *Juliette* at Santa Barbara Cove in Concepción Bay years before, Bill Yeargean and Jean Strain of the Honolulu-based Irwin 37 *Mita Kuuluu* returned for *Jimena*. Also riding it out there were the sailing vessels *Tequila Mockingbird* and *Rocinante*, and the motor vessels *Topaz* and *Oso Negro*. Reporting that they were just 30 miles from the eye, Bill and Jean said they had 75-knot winds with 15-second gusts of 100 knots over six hours. Rain was driven right through their dodger, and they couldn't hear each other from three feet away. At the height of the fury, *Mita Kuuluu* dragged her anchors but, thanks to the full power of a 50-hp Perkins, Bill and Jean were able to get her hooks to grab again.

Santa Rosalia — About 20 cruising boats scrambled to find spots at the relatively new marina, and each used every line they could find to tie to the pilings. Alex and Sue Hasenclever of the Kelly-Peterson 44 *Maitairoa* reported "nine hours of wind gusting to 90 knots." With her husband Dean working in Seattle, Toast Conger and her three young daughters aboard the Lagoon 380 *Don Quixote* tied up their boat in the marina, then took shelter in the Singlar building. According to Toast, the wind wasn't the problem. "We mostly had 40 and 50 knots, with only an hour of 60 knots. The real problem was that it blew like that from 3 p.m. until 11 p.m. It seemed like it was never going to stop." Succeeding levels of the building leaked so badly that Toast and her daughters ultimately had to take shelter in a tile-walled bathroom.

After *Jimena* surprised everyone by heading in the direction of San Carlos/Guaymas, the sense of relief at Santa Rosalia was short-lived,

continued on outside column of next sightings page

jimena — cont'd

because forecasts called for it to double back on them. Fortunately, it fizzled out in the Sea first. While all the Santa Rosalia boats survived in good shape, the small, old marina was destroyed, and the town suffered extensive damage from flash flooding. Cars were overturned, homes and stores destroyed, and one on-duty policeman was carried to his death by a wall of water and mud. For mariners, the big problem became the five cars, various household appliances and other debris that blocked the entrance of the marina.

Puerto Don Juan, Bahía de Los Angeles — Jake and Sharon Howard of the Seattle-based Hunter Legend 45 *Jake* report that theirs was one of 21 boats that took shelter at nearly-enclosed Puerto Don Juan in Bahía de Los Angeles. The storm was supposed to come within 50 miles of them, then head due west. But it “faked left and went right.” After a five-minute cloudburst in the middle of the night, they awoke to sunny skies. “To us,” the couple wrote, “it proved once again that this is the best place to be during the height of the Mexican hurricane season. Not only is it the safest, but it has great cruising, too.”

San Carlos/Guaymas — Although not originally predicted to get so close, the eye, depending to whom you talk, either came within 40 miles or passed right over the two towns. In any event, the boating center was hit by 40-50 knots of wind for 20 hours. No boats in the water at Marina San Carlos or Marina Real were damaged, but 20 boats on private moorings went up on the beach. These were mostly good-quality cruising boats, all of which had been unattended when they went ashore. All but three were pulled off in relatively short order.

San Carlos is the center of sailboat dry storage in Mexico, with close to 500 boats on the hard between Marina Seca and Marina Real. The big threat to them was not the wind, but the rain that fell in biblical amounts. More than 27 inches fell in 24 hours, supposedly twice as much as has ever fallen in a 24-hour period in Mexico. Marina Seca, the bigger of the storage yards, became a massive flood plain. Nonetheless, only two boats went over: the DownEast 38 *Barnacle* and the Passport 45 *Plumas*. Thanks to the thick cushion of mud, neither boat was damaged. All boats on the hard in Guaymas stayed up.

The flood damage that hit the city, roads and homes of the area was worse, yet cruisers had nothing but raves about the response on the part of the government, utilities, businesses and individuals. By all accounts, Kiki Grossman and her staff did a miraculous job clearing mud from Marina Seca, refencing the yard and getting it back on its feet. And Grossman raved about the utility providers and the hard work of her employees. She even put the workers' wives on the payroll so their husbands could work as many hours a day as possible.

Remember the looting hordes in the wake of *Katrina* in New Orleans? “There are marauding bands of Mexicans everywhere,” blogged one cruiser in San Carlos, “and they are helping everyone who needs it!”

We think the lessons of *Jimena* are as follows:

- You can't trust hurricane forecasts. Don Anderson was singled out as having better forecasts than others, but people complained that even his projections were way off.

- Unattended boats have a much greater chance to go ashore. Everyone must remember, however, that *Jimena* had lost a lot of her punch by the time she reached boating interests. It's one thing to stay on your boat in 60 knots of wind, it's another if it's blowing 120 knots and the force of the wind is four times greater.

- The farther north you are in the Sea, the less likely it is that you'll get hit; and if you do get hit, chances are you won't get hit as hard.

- Flash floods and flooding can be killers in Baja.

And lastly, in this time of danger, everyone banded together to prepare, endure and recover from the storm. It was humanity at its best. Nearly every cruiser who wrote to us struggled to find words to sufficiently express their praise for the Mexican government, the businesses, and the private citizens of Mexico for all their help.

— RS

cruisers psych up

Ahhh, Polynesia . . . Just saying that word, we can practically feel the warm caress of the trade winds.

Although the prime weather window for jumping off from the Americas to the South Pacific is still five months away, there's already a lot of buzz within the cruising community about this year's Pacific Puddle Jump. For the uninitiated, that's the name we coined long ago for the annual migration of westbound cruisers.

As most readers know, *Latitude ex-*



PHOTOS COURTESY GEMINI

for the puddle jump

pendes a lot of ink and effort on behalf of sailors who make this 3,000-mile open water passage, because completing it is a major accomplishment within the realm of world cruising. On the front end this year, we'll host our annual Puddle Jump Kickoff Party on February 6 at the Vallarta YC located in Nuevo Vallarta's Paradise Village Resort. We'll also be doing some 'outreach' to more southerly members of this year's fleet, thanks to friends at

continued in middle column of next sightings page

coincidence or crackdown?

Safety inspections by the Coast Guard are a way of life on San Francisco Bay. Long contested by the Fourth Amendment crowd, such searches have been upheld in court since the inception of the Revenue Cutter Service (which later became the Coast Guard) in 1790 by an act of the first Congress. Most Bay Area boaters comply patiently, if not happily, with these intrusions on our time on the water, and look at them as a necessary evil.

Longtime readers will no doubt recall the bad old days of 'Zero Intelligence/Zero Tolerance' more than a decade ago when *Latitude* campaigned against stepped-up boardings of recreational vessels. The publisher was later told by Sector San Francisco then-Commander

continued on outside column of next sightings page



PHOTOS COURTESY ESTRELLA



COURTESY HOBG

Though boating interests were largely spared by 'Jimena', they weren't left unscathed. Clockwise from here, two tris and a monohull washed ashore at Bahia San Carlos; most of the boats in Marina Seca dry storage stayed upright; a cruiser propped open a gate at Marina San Carlos; just one of several casualties of 'Jimena'; tons of flotsam washed up at Santa Rosalia; the main road at San Carlos washed out.

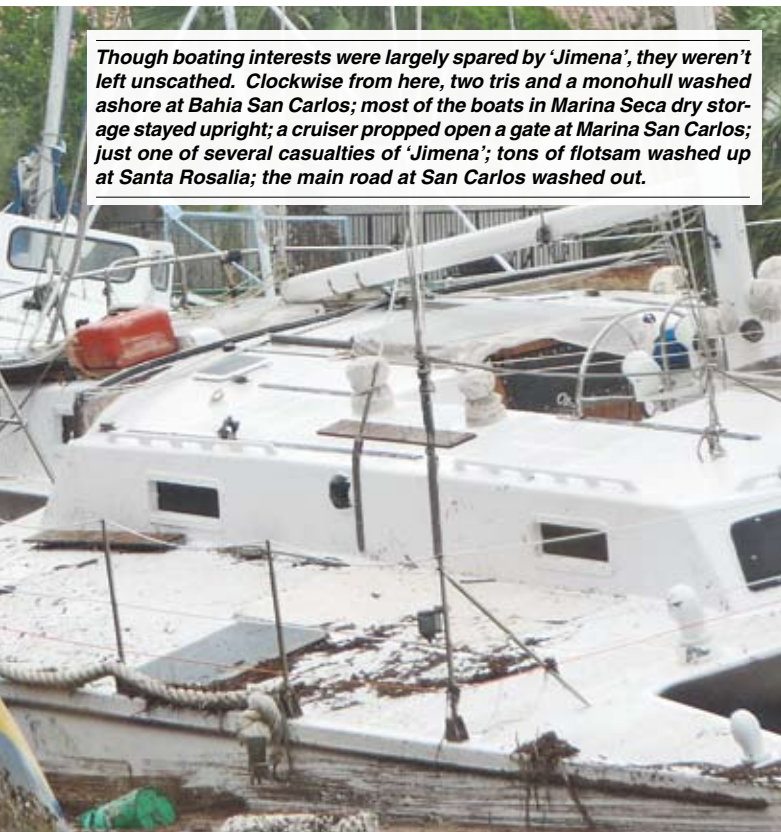

COURTESY PURA VIDA

SIGHTINGS

coincidence — cont'd

Capt. Larry Hall that his ravings had singlehandedly changed that policy. True or not, since that time, we've rarely received a complaint against the Coast Guard. More often than not, we get letter after letter commending them for assisting mariners in need.

So imagine our concern when, in a period of just a couple days, we received no fewer than three less-than-sterling reviews of recent Coast Guard interactions, all of which involved the racing community. The first, and most disturbing, episode occurred on August 25 during a Sausalito YC Beer Can race. After the start of the race, PRO Jeff Zarwell says he realized he'd forgotten to bring the 'anchor yanker' for the marks. He was operating the safety boat for the race, so he radioed the signal boat that he was returning to Schoonmaker Point Marina to pick it up — a trip that should have taken 10 minutes.

Zarwell reports that as soon as he entered Richardson Bay, a RIB from the Coast Guard vessel *Pike* began trailing him. Shortly before arriving at the marina, a 'mayday' was called on the race channel, VHF 71. According to Zarwell, neither he nor the signal boat received any other information, just the 'mayday'. "When I waved the RIB over and told them I'd received a mayday, they said 'We didn't hear

continued on outside column of next sightings page

puddle jump

the Panama YC (dates TBA). Officially registered fleet members (see www.pacificpuddlejump.com) will be profiled in the magazine. And thanks to our friends at the Tahiti YC, they'll likely be offered a special exemption from having to pay the normal entrance bond — a savings of roughly \$1,500 per person. You must register, however, before February 20.

On the back end, we're working with Tahiti Tourisme and other partners to co-host another Tahiti-Moorea Sailing Rendezvous on June 18-20 — a free three-day gathering to celebrate the fleet's successful crossing, while introducing members to Tahitian culture through traditional sports, music, dance and cuisine.

In addition, we'll be hosting three upcoming Puddle Jump seminars: 1) At the San Diego West Marine (1250 Rosecrans)

While few Puddle Jump boats are this elegant, they all reach the same dramatic Polynesian landfalls.

SPREAD: LATITUDE / ANDY. INSET: COURTESY EMERALD STAR



— cont'd

on Saturday, October 24 (5 p.m.), the day before the Ha-Ha Kickoff Party; 2) At the Seattle Boat Show in January (specifics TBA); 3) At Oakland's Strictly Sail Pacific show in April (again, TBA).

In Puerto Vallarta, a wide variety of worthwhile seminars is being scheduled at both the Vallarta YC (www.vallartayachtclub.org) and Marina Riviera Nayarit (www.marinarivieranayarit.com).

Finally, every potential Puddle Jumper should check out the 'PacificPuddle-Jump' group site at Yahoo.com (under the 'Groups' menu), which contains a wealth of useful info related to making the crossing. Be aware also that most Puddle Jump articles published in *Latitude* can be downloaded for free at www.pacificpuddlejumper.com. See you out there!

— andy



coincidence — cont'd

it," Zarwell recalls. "I then had to explain that it came over the race channel and why a racer might think he'd have a chance of nearby boats hearing him on that channel. One of the men asked for my cell phone number — which I had to repeat five times before he finally wrote it down — and then I was told to continue to the dock."

Once there, Zarwell reports that he received a call from the officer aboard *Pike*, and once again had to explain the situation: A racer had called a mayday, and that, as the safety boat, he should go find out what had happened. "I was told that as soon as the safety inspection was complete, I could go check on my boats." He says this whole interaction took about 10 minutes, not including the time it took to conduct the inspection (he passed). "It's unbelievable that they let a safety inspection take precedence over a mayday call!"

What no one knew — not Zarwell, not the signal boat, not the Coast Guard — was that, while all this was going down, a flawless man-overboard rescue had been performed just outside Richardson Bay. In the midst of a spectacular spinnaker blow-out, a crewmember aboard Dale Flaming's *J/133 J/Hawk* fell overboard, only to be rescued within moments by the crew of Charles James' *J/105 Roxanne*. Zarwell reports that the crewmember was not wearing a PFD, and was inappropriately dressed, so he already showed signs of hypothermia after just a few minutes in the Bay. Other than that, he was unhurt. Zarwell fired off an irate letter of complaint to the Coast Guard — cc'ing *Latitude* — shortly after the incident.

Fast forward to Labor Day, three days before the Rolex Big Boat Series was to commence. Brent Vaughan was out practicing for the event with his full crew aboard his St. Francis YC-based *J/105 Jabberwocky*. "We were sailing to weather, hiking within the *J/105* rules, on a port tack about 500 yards off Golden Gate YC," Vaughan recalls. "A Coast Guard RIB came tearing out of Gashouse Cove and passed behind us. I thought they were saying hi so I waved. Instead, they came up next to us and said that my crew had to get inside the lifelines. I must have looked dense because I really didn't understand. They told me no one could have their legs hanging outboard!"

Vaughan says he told the men on the RIB that he and his crew were practicing for a race. "Where's your patrol boat?' they asked. It was truly bizarre. I asked them what they were talking about, and they said, 'You have to have a patrol boat if you're practicing.' I told them that I was pretty sure that California state law does not require me to buy a powerboat before I can sail my sailboat."

At this point Vaughan says things started to get contentious. "I was about two comments away from them boarding us so I just told my crew to pull in their legs and we'd practice on the other side of the Bay. I'd paid for Olympic silver medalist Jeff Madrigali to come up early for practice and I didn't want to waste three hours going down

continued on outside column of next sightings page



PHOTOS TIM SELL

In this amazing sequence, 'Roxanne' can be seen coming to the rescue.

coincidence — cont'd

their checklist. In the end, they said the rule was a state statute so they wouldn't cite us, but that they'd 'be happy to call the sheriff, and they won't be as understanding as us.' Like I said, truly bizarre."

Then came a report that a BBS race committee boat was boarded for a safety inspection — not only during the middle of a race, but in the middle of the race course. One person onboard told us that the Coast Guard vessel *Tern* stayed on station in the middle of the course, forcing racers to go around them. Perhaps not a big deal normally but, combined with these other incidents, a potential red flag.

"There's no mandate to crack down on sailing vessels or the racing community," insists Sector San Francisco Public Affairs Officer LTJG Jeremy Pichette. "If there's some disconnect between the Coast Guard and the boating public, that's something we'd like to address. We take complaints very seriously. Our top priority is to ensure the safety of our crews and the boating public."

Lt. Pichette reports that an internal investigation of Zarwell's complaint was completed at the end of last month. "It was found that all Coast Guard personnel abided by training and instructions," he said. "The boarding occurred north of the race location, so Mr. Zarwell's safety boat was not near the scene of the crew overboard." He noted that the officer aboard *Pike* relayed the mayday to Search and Rescue who then gained contact with *Roxanne*. "They were told no other Coast Guard assistance was needed."

It's worth noting that no complaints were filed in the other cases, and Lt. Pichette confirmed that the crew of *Jabberwocky* were not violating any laws. "That rule only applies to powerboats," he said.

So how can the "disconnect" that Lt. Pichette mentioned — if there even is one — be fixed? "Maybe they should put together a panel with members of the boating community," suggests Jeff Zarwell. "It doesn't seem that they know who it is they're supposedly serving."

If such a group were to form, one point of discussion would be how to avoid the inspection of race committee boats during active racing. A reasonable solution would be annual inspections that would exempt them from further boardings. That simple change would have prevented two of these incidents.

Whatever the solution, it's clear that the Coast Guard is willing to play ball — the boating community just has to step up to the plate.

— *ladonna*

the birth of a new *neraida*

In the wee hours of June, 19, 2008, British solo circumnavigator Jeanne Socrates slept as her Najad 361 *Nereida* veered toward the shore of Playa Michigan, situated between Acapulco and Zihuatanejo. Socrates had left Zihua 15 months earlier on a west-about circumnavigation via the Panama Canal, and was just 60 miles from crossing her outbound track when her autopilot failed and *Nereida* was lost on that desolate Mexican beach.

Jeanne spent days recovering what she could from the wreck, giving much of it to local fishermen, and sending the rest to San Francisco aboard another cruiser's boat. There she stored the gear in a friend's garage as she began the process of finding a new boat to call home.

Socrates, a veteran of the '06 Singlehanded TransPac, had signed up for the '08 running of the race, but she didn't let the loss of *Nereida*, just a month before the start, stop her from joining her old friends at the finish line. It was a

continued on outside column of next sightings page

baja ha-ha draws

Much to the surprise of the Baja Ha-Ha Rally Committee, the number of paid entries for the 'Sweet Sixteen' Ha-Ha blew by the old record of 183 boats to a total of 191 boats. Who would have thought?

There will be some new twists to this year's pre-rally activities. A consortium of San Diego port staffers, business people and Harbor Police have been working to make the fleet's visit more fun and more high-profile than ever.

On the way out to the October 26 start, Ha-Ha boats will parade past the tip of Shelter Island at 10 a.m., where a San Diego fire boat will salute them with a cloud of spray, while local print and TV news outlets record the procession — your

Spread, Jeanne Socrates aboard her new 'Nereida'. She oversaw nearly every aspect of her build, making dozens of small changes and several larger ones, such as changing her sail plan to a cutter. Inset, the original 'Nereida' as she lay dying on a forlorn Mexican beach.



record numbers

chance to get on the evening news. The head of Baja tourism has been invited to attend and officially start the parade with a blast from the special starter's shotgun used during the 1988 America's Cup held in San Diego.

While we're gratified that so many boats decided to enter, our primary concern is that everyone make it to Cabo safely. For this reason, we want to emphasize how important it is for all skippers and crew to make sure that the boat and all the crew are ready to sail offshore. It starts with personal issues. Everybody needs to understand the importance of not going overboard, getting hit in the head by the

continued in middle column of next sightings page

neraida — cont'd

bittersweet reunion, to be sure, but one that brought Jeanne a sense of closure — especially when, shortly before the race's final party, she learned that her insurance company, Lloyds of London, had honored her claim in full.

Instead of continuing to scour used boat ads on the internet, Socrates contacted Najad Yachts in Sweden and began an eight-month process of having a new boat built to her exacting specifications. Having sailed the first *Nereida* thousands of miles with her late husband George, and then tens of thousand on her own, Jeanne was intimately familiar with the changes she wanted made.

The new *Nereida* was launched this past April, and Jeanne spent the summer commissioning the boat and otherwise prepping it for her next goal: A singlehanded, nonstop circumnavigation via the Great Capes. If she completes the trip, which she expects to take six or seven months, she says she'll be the oldest woman do have done so — but she's not saying exactly how old that is. "Let's just say that I'm in my 60s," she noted. "I don't believe a woman over 60 has ever

continued on outside column of next sightings page



PHOTOS COURTESY NEREIDA

SIGHTINGS

neraida — cont'd

done it. Sir Robin Knox-Johnston commented that, if I succeed, I'll be the nineteenth Brit ever to have done so solo, nonstop."

Early last month, Socrates set sail from Guernsey on a 12-day shakedown cruise to the Canary Islands. When we caught up with her, she was just a week or so away from her anticipated departure date. "There are still items to fix in place so they won't move around in the expected big seas — or if we should broach or invert — but I hope to be ready to get underway by the beginning of October," Jeanne said, "so as to be in the area of Cape Horn around mid-January."

Socrates also hopes to raise money for a charity close to her heart: Marie Curie Cancer Care. "Too many people I know have suffered from cancer, and it has denied them the chance to enjoy what they'd looked forward to, often after a hard-working life," she said. "Some friends are still struggling to overcome it. Marie Curie Cancer Care enables terminally ill people to spend their final days at home, with the family supported by dedicated nurses provided free of charge."

ha-ha

boom or spinnaker pole, or losing one's fingers in a block. Then there are boat safety issues, such as everyone's knowing the importance of keeping a good watch and knowing how to reef. And knowing how to deal with emergencies, such as fire, water coming into the boat from an unknown source, losing the rudder, or having the mast come down.

We don't want to frighten anyone, because these things have rarely or never happened in the previous 15 Ha-Ha's but, in order to be safe, you must have knowledge and be vigilant. Besides, the more you know, the more relaxed you'll be and the more fun you'll have.

'Sweet Sixteen' promises to be the biggest Ha-Ha if all 191 entries show up to the starting line.



— cont'd

Speaking of safety, the Mexican Navy wants all fleet members to know they have recently expanded their Search and Rescue fleet dramatically, with new helicopters and U.S. Coast Guard-style runabouts, based out of Ensenada, that are capable of 50 knots. Their personnel have been trained by the USCG, and all speak English.

As you'll read in our second installment of profiles, this year's fleet has some very interesting characters, and some very accomplished offshore sailors. We look forward to meeting them all — in fact, we can hardly wait for the Ha-Ha to begin.

— andy



neraida — cont'd

We'll publish Jeanne's updates periodically, but in the meantime, you can track her progress — as well as donate to her charity — at www.svneraida.com.

— ladonna

shake rattle and roll —
remembering the quake of '89

No one who experienced the 1989 earthquake in Northern California will ever forget where they were or what they were doing in the early evening hours of October 17. Though the 6.9 temblor was not nearly as powerful as the Great Earthquake of 1906 (estimated to have been a Richter magnitude 7.8), the Loma Prieta quake will always be the 'Big One' of our time.

To refresh your memory: shortly after 5 p.m. on October 17, the San Andreas fault slipped in an area 10 miles northeast of Santa Cruz. The

actual epicenter was in Forest of Nisene Marks State Park, but the quake soon took on the name of nearby Loma Prieta Peak. The main tremor lasted for 10-15 seconds and, according to varying reports, was felt as far away as San Diego to the south, Southern Oregon to the north, and Western Nevada. When the final numbers were tallied, 63 people had been killed, more than

3,700 injured, and upwards of 10,000 left homeless. Some 12,000 homes and 2,600 businesses were damaged or destroyed. Forty buildings collapsed outright. Most of the fatalities occurred when the top deck of the double-decker Nimitz Freeway in the East Bay collapsed onto the bottom deck, crushing scores of cars. The most concentrated damage occurred in the Marina District of San Francisco, where we all learned about a thing called 'liquefaction', in which landfill over marshy areas amplifies the shaking — and the destruction. The quake caused an estimated \$6 billion (\$10 billion in today's dollars) in property damage, becoming one of the most expensive natural disasters in U.S. history at the time.

Although we 'covered' the boating aspect of the quake in our November issue that year, the reality is that, back then, and for months to come, sailing didn't matter. All that mattered was making sure loved ones were okay, you had someplace warm and dry to sleep, and that you could put your life back together.

But that was then. On this, the 20th anniversary of Loma Prieta, we asked readers (via *'Lectronic Latitude'*) to remember where they were and what happened that day — but only if it related to boating. The stories we got were so great we wonder why we didn't ask the same thing years ago. From one couple who completed a 21,000 mile circumnavigation of the Pacific that day when they sailed under the Gate to the sailor who helped ferry people to the East Bay, all the stories were riveting.

Instead of editing them down to fit our space limitations, we've posted the best ones on our website at www.latitude38.com/features/lomaprieta.html.

— jr



LATITUDE / JR

The marina fire as seen from the Marin Headlands.

ROLEX BIG BOAT SERIES



When it was announced at last year's awards ceremony that the '09 Rolex Big Boat Series would function as the US IRC Nationals, we were hopeful it would turn out to be one of the biggest and best in recent memory. That was, of course, before the bottom dropped out of the economy. All of a sudden we were left wondering just how many boats would actually make it.

Thankfully, the developing strength of the West Coast IRC fleet meant that the 45th anniversary of the regatta — held September 10-13 — showed you can't keep the West Coast's premier event down. Although the fleet of 95 boats — 29 in four IRC divisions and 66 in seven one-design divisions — was about

Jim Mitchell's IRC A-winning R/P 52 'Vincitore' also took home the 2009 US IRC national title.

16 shy of last year's total, the quality was high, and the mass sufficient to produce both great racing and spectating.

Along with their typically excellent race management and parties, hosts St. Francis YC and Rolex broke new ground on the spectator side of things, adding features like live race tracking for the IRC divisions with mark-by-mark updates that included corrected times.

Coinciding with the 20th anniversary of the passing of the still-admired Tom Blackaller, this year's event kicked off with an open mic tribute to the two-time Star world champion, America's Cup campaigner and one of the most colorful

in the pantheon of Bay Area sailing characters.

After an awesome opening two days, with breeze into the low 20s and sunshine, the one thing no one had any control over — the weather — produced a somewhat anti-climactic coda to the regatta. Frontal activity rolled in Friday night, bringing with it thunderstorms and lightning and killing any chance of consistent breeze, or sun, for that matter, on the final two days. Although two races were held on both the Cityfront and North courses on Saturday in a relatively steady breeze that never got above 10 knots, Sunday was a different story. The regatta ended with a bang for the four IRC divisions as well as the

— HANGIN' TOUGH IN '09



J/120s and 1D35s — actually three bangs to be exact, when a huge hole that marooned the only fleet to start — IRC A — at the southeast corner of Alcatraz as it made its way down the first run, and racing for all the fleets on this course was abandoned. The North Course boats were able to sail a final, shortened race that cemented the winners in the Express 37, J/105, Beneteau 36.7, Cal 40 and Melges 32 classes, though it produced no changes in winners.

That meant no final day Bay tour and boat parade in front of the club, much to the chagrin of just about everyone we talked to. Also absent, due to fog outside the Gate on Friday, was a race to Pt. Bonita for the bigger boats.

Yet these aren't the kinds of things that'll keep people from coming back, and, if nothing else, the locals could finally have the pleasure of telling the out-of-towners a line they don't often get to use — "It's never like this here. . . ."

IRC A

Although it featured four TP 52s — probably the most together for a regatta in California since the class began almost a decade ago — IRC A went to the only purpose-designed IRC boat, Jim Mitchell's R/P 52 *Vincitore*. Mitchell was back this year to improve on last year's runner up spot with a new team including Chris Dickson on the wheels, and Norman Davant on tactics.

"We talked about last year's regatta all year long," said Mitchell, a native of Chicago living in Switzerland. "We had a motto this year, super-fine in 2009."

After coming out of the blocks strong with a pair of bullets, *Vincitore's* lead evaporated in races four and five on Friday afternoon and Saturday morning respectively. A pair of fourths in those two races dropped them into a tie with Tom Akin and Mark Jones' TP 52 *Flash*, which scored a 1-1 in the same two races. Helmed by Jeff Thorpe with Paul Cayard calling tactics for the first two days and navigator Artie Means filling in for Cayard — who had a previous MedCup commitment — for the second two, *Flash* wound up scoring a third to

ROLEX BIG BOAT SERIES



The 'Vincitore' brain trust — from left, Chris Dickson, Jim Mitchell, Norman Davant, Rodney Keenan and Colin Booth put it all together against a competitive fleet of TP 52s to take IRC A.

Vincitore's second in what would prove to be the final race.

When Sunday's race was abandoned with *Flash* leading on corrected time as the fleet parked at the southeast corner of Alacatraz, the regatta win — and 2009 IRC National title — went to Mitchell's electric-blue speedster.

Although the racing was generally tight — four of the five boats were often within boatlengths of each other on the first beats of the races — Dickson said he felt *Vincitore* had a speed edge sufficient to overcome its higher rating.

"We were definitely the quickest boat downwind in both the light and the heavy," he said. "In light air, I think we were quickest upwind, but in the breeze, *Samba Pa Ti* and *Flash* were a bit quicker."

For Mitchell, the win, which came with the St. Francis Perpetual Trophy, was especially gratifying as his father Jim Sr. — who introduced him to the sport — was there to see it happen.

"This is a very emotional win for me," the younger Mitchell said. "At the end of racing, when I looked at my dad, who was out on the chase boat, we both had a tear in our eye. The speech I gave on the first day was that we have a passion for sailing, a passion for friends and family, and we will let the results speak for themselves."

That they did. If Mitchell's crew, which also included David Blanchfield, Colin Booth, Mike Buckley, Hayden Goodrick, Martin Hannon, Nathan Hislop, Rodney Keenan, Dallas Kilponen, Simon Minoprio, Brent Ruhne, Chris Skinner and Jack Toliver made any mistakes, we missed them. According to Mitchell their effort wasn't a two-shot deal.

"We are bringing *Vincitore* back again next year," he promised.

IRC B

IRC B was hands down the wackiest division of all. Featuring everything from a pair of Farr 36s to the division winner, and biggest boat in the regatta, Kjeld Hestehave's San Diego-based Tanton 73 *Velos*, IRC B was a mish-mash of displacement and planing boats pretty much covered the last three rating rules and the last four decades. The scratch boat was Chris Welsh's IRC-optimized Spencer 65 *Ragtime*, but it was all *Velos*, all weekend.

"This win is 12 years in the making," he said of winning the City of San Francisco Trophy and culminating in a four-time Rolex Big Boat Series ef-

Inset, from left — Kjeld Hestehave, Chuck Skewes and Will Stout, seen here with what would be a fitting Rolex for the biggest boat this year; Spread — Hestehave's Tanton 73 'Velos' dwarfed IRC B, spare the scratch boat, Chris Welsh's Spencer 65 'Ragtime' (not pictured).

fort. "We were here in '97 and '98, and we got two second places that year. We were here two years ago and got killed by everyone."

The IOR design used her relatively prodigious waterline to break away from the rest of the 10-boat pack at the start line and never looked back, sailing in clean air the entire time and giving her afterguard — comprised of San Diegans Will Stout and Chuck Skewes — any lane they wanted.

The duo took full advantage, and with the help of the generally non-planing conditions and some crisp boathandling from the 22-person crew — got the big boat around the course fast enough to reel off six-straight bullets. But Stout felt their size did carry some limitation.

"On the starting line, we're really not that manoeuvrable," he said.



— HANGIN' TOUGH IN '09



LATTITUDE/ROB



SHARON GREEN/WWW.ULTIMATESAILING.COM

Hestehave is also an avid Etchells sailor and *Velos'* main sported an Etchells insignia on the head.

"It was a little too big to measure in," he cracked.

Dale Williams' brand-new Kernan 44 *Wasabi* was the best of the rest, fending off Sy Kleinman's strong-finishing Schumacher 54 *Swiftsure II* to take second on a countback.

IRC C

Dan Woolery's Pt. Richmond-based King 40 *Soozal* won what was probably one of the two toughest divisions in the regatta. In doing so, *Soozal* took the Richard Rheem Perpetual and also wrapped-up the SF Bay IRC season championship. Featuring two previous division winners in Brad Copper's Tripp

'Soozal' took IRC C; Inset — Tactician Robbie Haines, left, and owner/driver Dan Woolery.

43 *TNT* and John Siegel's Wylie 42 *Scorpio* — neither of which cracked the top three this year — the eight-boat IRC C was tight, with one of the closest rating spreads and some of the most similar boats. With Robbie Haines calling the shots and rockstar crew that included Hogan Beattie, Matt Siddens, Chris Lewis, Scott Easom, Gary Sadamori, Pete McCormick, Rob Moore and Greg Felton, Woolery sailed the boat to yet another division win in a successful year, which included wins at Key West Race Week and the Pineapple Cup to name a few.

"I'm pleased with the win, but even more so because it capped a successful year-long effort," Woolery said. "The most important part of the formula was selecting the right mix of people that fit the sailing style that I am accustomed to. Knowing that we would ultimately end up sailing in the Bay for the summer, we wanted a crew that was local to our area, had plenty of racing experience and most importantly, had the personalities that befitted our program. I am a low-key guy, and love to sail with knowledgeable, low-key people. This was paramount as we were to spend the entire year sailing together, and didn't want to go through any crew changes if at all possible. We were also fortunate to have backups that fit these criteria as well if someone was unable to make a regatta."

Winning the IRC Nationals was the goal for the *Soozal* program this year, and while Woolery certainly put together the kind of effort required to do that, he was philosophical about the outcome.

"We had a very satisfying year — a fairy tale year of remaining on top in the 40-foot range against the boats we sailed against on the East Coast in the Grand Prix events, and the IRC boats we raced against here on the West Coast. Sure, it would have been a nice honor to have emerged at the top of the Nationals, but considering the type of boats racing in Division A, and the venue, we're very proud of what we accomplished, and feel we sailed as hard as we could have. We still believe we've had the experience of sailing on one of the fastest IRC 40-footers out there."

The runner-up spot in the division went to the only east coast entry, James Bishop's J/44 *Gold Digger*. Tim Fuller

Gerry Sheridan, left, and tactician James Mullarney put 'Tupelo Honey' in all the right spots, namely first in every race in IRC D.



LATTITUDE/ROB

ROLEX BIG BOAT SERIES

LATITUDE/LADONNA



'Chance's Barry Lewis couldn't be happier with the namesake of what turned out to be his good luck charm — a Mr. Magoo sticker on the bowsprit.

— who you may remember won his division aboard his other boat, the turboed 1D35 *Relentless*, in this year's TransPac — took third with his J/122 *Resolute*.

IRC D

Gerry Sheridan's San Francisco-based *Elan 40 Tupelo Honey* used the occasion of this year's RBBS to bookend its three-straight runner-up finishes since a division win in 2005.

With straight bullets, Sheridan and his tactician — and fellow Irishman — James Mullarney scored an emphatic win, finishing six-points clear of Timothy Ballard's San Rafael-based Beneteau

Sheridan said. "We really wanted it this year. We trained for it and the crew is outstanding. Every single one of them deserved to be on the crew."

In addition to Sheridan and Mullarney, the *Tupelo Honey* crew included Fabrizio Natale, Bill Nielsen, Jamie Platto, Mike Reed, Adam Simmonds, Arne Vandembroucke, Bart von Zastrow and Kevin Wilkinson.

Third in the six-boat division went Frank Morrow's IMX 38 *Hawkeye*.



John Wimer's team on 'Desdemona' turned it up this year, finishing second to 'Chance.'

pushed hard around the course by John Wimer's *Desdemona*. In what's become standard operating procedure for the class at the Big Boat Series, the regatta wasn't decided until the final run of the final race of the series.

"Going into the sixth race on Saturday we were one point behind *Desdemona*," Lewis said. "We led the entire race with *Desdemona* in second. Our tactician, Doug Nugent, said, 'We need to put a boat between us,' so we held back and sat on *Desdemona* which allowed Steve Madeira's *Mr. Magoo* to pass them. It blew up in our face because *Magoo* passed us too! Around the final weather mark we had *Desdemona* on our tail with *Magoo* five or six boatlengths in front of us. But *Magoo* twisted their kite, and we ended up bow to bow for the last 100 yards before we nosed them out by no more than 10 feet."

When Sunday's final race was cancelled, Nugent's call looked pretty good as the *Chance* crew — which also included Scott Kozinchik, Blaine Pedlow, Matt Gingo, Michael Redmond, Amy Guarneri, Aaron Elder, Mark Ruppert, Bryan Murdock and David Krausz — won on a countback.

"Of course we didn't know that Sunday's race would be cancelled," Lewis

LATITUDE/LADONNA



The 'Good Timin' gang racked up yet another title at the RBBS in the J/105 division.

40.7 *Inspired Environments* to take the Keefe-Kilborn Perpetual. But Sheridan said that it looked easier on paper than it was on the water.

"*Inspired Environments* sailed really well and pushed us the entire time,"

J/120

The J/120s can always be counted on to provide one of the closest contests at RBBS, and this year was no exception for the eight-boat fleet. Defending champion Barry Lewis and his gang on *Chance* got

— HANGIN' TOUGH IN '09



LESLIE RICHTER/WWW.ROCKSKIPPER.COM

This year we decided to get our bad race out of the way on Thursday. Other than that, we had all firsts and seconds. We were determined that it wasn't going to stop us from sailing really hard, as it was quite close with the top couple boats sailing fast the entire regatta and *Desdemona* sailing better than they have in Big Boat Series in very long time."

J/105

Chris Perkins has been sailing his J/105 *Good Timin'* in Big Boat Series since '00; in that time, he and his core crew of Dave Wilson, Pete Scott, Tom and Melissa Purdy, Jon Perkins and Darren Ward have won their division at least five times. But Perkins isn't keeping count.

"It's not that important to us," Perkins said. "We look forward to each and every regatta. Big Boat Series is so special because it's home for us, and the biggest regatta on the Bay for the 105s."

Even so, Perkins said it wasn't until about a month before the regatta that he decided to sail. He hadn't sailed the boat all year, due in large part to the fact he's been working in San Diego as CFO for BMW Oracle Racing.

"The crew said, 'Hey, how come we're not sailing this year?'" Perkins said. "We decided to do it, then I realized the winches hadn't turned since April, we didn't have a bottom on the boat, etc."

After hurriedly preparing the boat, the *Good Timin'* crew put their experience to work for them, suffered no breakdowns,

and sailed a consistent series without a single bullet, to finish four points clear of Bruce Stone's *Arbitrage*.

"Bruce had his boat going phenomenally fast," Perkins said. "It was clear he had the best speed of any boat. We were happy with our speed, and we just hung out, didn't try to win any races, bang any corners or 'ring the bell.'"

"Big Boat Series is different from the normal class events," Perkins said. "Instead of staying in relatively confined racing area, you're out there traversing the Bay and making some do-or-die decisions."

Stone scored three bullets, a second and two sixths, but Thursday's second race proved to be his undoing, as a 15th in the 25-boat fleet put him behind the eight ball. The leader after day one, Jeff Litfin and John Case's *Mojo* also sailed a consistent series to finish three points behind *Arbitrage*. Howard Bentley's *Swoosh* found some previously untapped speed to notch a bullet in the series and slide into fourth when Tim Russell's *Aquavit* slipped up in the fluky and shortened Sunday race on the North Course and scored a 22nd, which dropped them from a tie for second to fifth.

1D35

The 1D35 was the other one-design class whose regatta was cut short by Sunday's weather. Like the J/120s, the competition within the seven-boat fleet was close. Like the 120s, the regatta produced a repeat winner. Five boats scored

Philippe Kahn's Melges 32 'Pegasus' pulverized the Bay during Friday afternoon's breezier race.



SHARON GREEN/WWW.ULTIMATESAILING.COM

said. "But that was a great call by Doug — we've never not raced on a Sunday and it came as a surprise."

Four boats led the division at various points during the regatta, and *Chance's* win came despite restarting after being called over early in the second race.

"We had a real hard time climbing back through the fleet," Lewis said. "Normally for us, it's a 'bad Saturday' event."

ROLEX BIG BOAT SERIES



LATITUDE/ANDY

Tactician Rick Schudt and owner/driver Gary Boell had 'Diabalita' atop the podium in the 1D35s for the second consecutive time.

at least one bullet, and only two points separated second through fourth places after a three-way tie for first was broken in race five. Despite a 30% penalty for a Cityfront short-tacking infraction, Gary Boell's Richmond-based *Diabalita* held on for a win, to finish four points clear of the regatta's only Japanese entry — a crowd favorite — Masakazu Toyama's chartered *Ebb Tide*.

Despite the tight racing, the most intense moment of the regatta for Boell came at around 10 a.m. Saturday morning, when he realized they'd wrapped a spinnaker sheet around their prop on the lee side of Alcatraz, shortly before the start of race five.

"I had to strip down to my red boxers with white hearts on them, and do four dives under the boat to clear it," Boell said.

Backing up Boell were tactician Rick Schudt, Geoff Love, Chris Loughran, Cyril Guaraud, Randall Landaiche, Ellen Hoke, and Tone Chin, all of whom are Category 1 — non-pro — sailors, who with the exception of Love, were returning from the boat's '08 win.

The *Ebb Tide* crew — back for its third attempt in the fleet — included two former America's Cup campaigners and sailed well, but they suffered at times from a lack of local knowledge. At the awards ceremony the team received a prolonged ovation from the crowd — and showed why, when they presented Boell with a bottle of premium sake that they'd brought for the division winner.

Beneteau 36.7

The Beneteau 36.7s fielded a one-design division for the second year in a



LATITUDE/ANDY

Crowd favorites, the Japanese entry 'Ebb Tide.'

row. Before sliding to second by the end of the regatta, Aaron Kennedy's *Ay Caliente!* jumped out to an early lead in this competitive six-boat group, which saw last year's winner, Ed Durbin's *Mistral*, finish third, and last year's runner-up, Pat Patterson's Bellingham, Washington-

based *Summer and Smoke* finish five points clear of *Ay Caliente!*.

"Three different boats took first in the first three races," said Patterson, who dedicated the win to his wife Leanne and their 30-year anniversary, which coincided with the event. "It was all spread out — anything could have happened. We clawed our way to second last year. This year we got lucky."

The *Summer and Smoke* Crew, which included the Bay Area's Bill Colombo on tactics and Victor Beltran navigating,



LATITUDE/ROB

Bill LeRoy, inset, and his Cal 40 'Gone With Wind' were gone with the division's title after a 2-1-1-2-1-1-1.



ROLEX/DANIEL FORESIER



Dave and Brock Steffen, Terry Tavelli, Gabe Murphy, Erik Smitt, Keith Rarick, and Mike Spencer-Smith, sailed well enough to score a 3-3-1-1-2-1.

"Our win was all about our great crew," Patterson said. "They're mostly from Bellingham YC. . . and most came last year also. Our MVP was 18-year-old Brock Steffen from Bellingham. He launched every kite perfectly, without a single problem."

Express 37

If the competition among the Express 37s seemed a little heated it was because the nine-boat division was sailing for one of the most coveted trophies in Bay Area racing. No, not the Rolex that awaited the class winner for the second consecutive year. We're talking about the vaunted Timex Cup! With its origins in the days of the class' perpetual snubbing of the fancier timepiece — despite being its longest-running one-design class — the Timex Cup Perpetual, a dime-store watch mounted haphazardly with duct tape on an irregularly-shaped piece of plywood, has become the class talisman.

Kame Richards won both the Timex Cup and a Rolex this year aboard *Golden*



LATTUDELADONNA

Rolex? What Rolex? Kame Richards and Bill Bridge's 'Golden Moon' took home both the Express 37 class's coveted 'Timex Cup' Perpetual, and a fancy watch for a consistent, winning performance.

Moon. Backed up by tactician Scot Owens, Richards, boat partner Bill Bridge and the rest of the "Moonies" — Tom Paulling, Jamal Berkeley, Brad Jeffry, Todd Hedin, Mike Mannix, Andrew Hura, David Liebenberg, Lynn Davis and Aimee Daniel — got out of the blocks strong on Thursday, scoring a pair of bullets.

"One of the hardest things for me to control is my stress level," Richards said. "So it was refreshing to have various crew members remind us we don't have to win every race. With two wins on day one, we were sitting pretty. But on day two, we got a second and a third and were feeling fragile, until someone reminded us we still had a very comfortable lead."

Relaxed and groovin', the Moonies sailed to a very consistent 3-2-3-3-3 in the next three days to fend off Mick Schlen's Southern California-based *Blade Runner*, which followed its opening 5-6 with a 1-1-2-1-2 to get within two points of *Golden Moon*.

"The best part of the whole thing is the people who own the boats and people who crew on the boats," said Richards, who won his division for the third time in the last seven years. "What makes a one design strong is not how new it is; that's not it. There's a special glue, a societal kind of glue. Ron Moore once said, 'The boat chooses you,' and I wonder if that's not what the Express 37 has done to us."

Cal 40

Perhaps the coolest thing at this year's Rolex Big Boat Series was the advent of the Cal 40 one design division. And as good as it was to see six examples of the classic Bill Lapworth design racing against each other on the Bay, it was even better to see how well-kept they are. The true peach among this cherry fleet was Bill LeRoy's *Gone With the Wind*, which handily won the division with five bullets and a pair of seconds. LeRoy, who came to the boat following the break from sailing after successfully campaigning an

SC 50 by the same name, put together an effort as impressive as the restoration of the boat.

"I was talking with Stan Honey, and I asked him if there were any Cal 40s around," LeRoy said. "We started discussing the design and the more we talked, the more apparent it became that it was exactly what I wanted in a boat. It doesn't have any bad habits and it has a safe and secure cockpit for taking my grandchildren sailing."

He found a boat last year and began a restoration that went, "way over budget," and culminated in a beautiful boat, a Big Boat Series win, and big plans for next year.

"We're going to ship the boat to the East Coast to do both the Bermuda Race and some cruising," he said. And when he does, he'll doubtless get the same reaction he said he's gotten here at home.



LEEANNE PATTERSON

Pat Patterson and his Bellingham, Washington-based 'Summer and Smoke' team came down to raid the Beneteau 36.7 division title.

ROLEX BIG BOAT SERIES



SHARON GREEN/WWW.ULTIMATESAILING.COM

"When you tell people you have a Cal 40, they light up and say, 'Ohhh.'"

The battle for second went to Steve Waterloo's *Shaman*, which pulled away from Rodney Pimentel's *Azure* in the final races of the regatta.

Melges 32

The Melges 32s were sailing for their U.S. National Championships; unfortunately you wouldn't know it, given that only five entries showed for the regatta. With the class' World Championships beginning in Sardinia a week-and-a-half later, the deck was stacked against the class' chance of matching last year's total of nine entries that included two European teams.

But the lack of entries didn't translate into ho-hum racing. Mill Valley's Don Jesberg and his all-corinthian team on *Viva* — which had won the seven-boat North Americans held earlier in the week at Sausalito YC — battled with Andy Lovell and Burton Benrud's Louisiana-based *Rougarou*.

Rougarou finished strong, posting a pair of bullets on Saturday to pull away and finish three points clear of *Viva*. Stephen Pugh's Sausalito-based *Taboo* rounded out the top-three, another three points behind *Viva*.

With 45 years under its belt, the '09 Rolex Big Boat Series proved the regatta can hold its own no matter what's

Andy Costello's Pt. Richmond-based J/125 'Double Trouble' screams downwind.

happening in the greater economic context. It also proved that IRC can do the same, and while there are some areas that could use improvement, many people — whether they like the rule or not — agree that it's working better than anything that preceded it.

Count IRC D winner Gerry Sheridan among them:

"I think IRC is saving big boat racing around the world," he said. "It's giving a new sense of purpose to racing and serious big boat campaigns. Handicap racing is never perfect, but this is close to perfect."

Newly-crowned National Champion Mitchell agreed:

"I like it, and not because we won," he said. "With IRC, your boat's not obsolete every year. I didn't design it as a stripped-out boat; it has a proper galley, cherry-wood floors, benches in the cockpit for when I take my dad and friends sailing, plus it's comfortable for distance races."

Yet another division winner, Dan Woolery, pointed out that despite the success he's had with *Soozal*, there are still some areas in the administration of the rule — which in the 45- to 50-ft range begins to favor lighter displacement, more power, and planing hull forms — that need work.

"Most of the sailing venues around the

U.S. typically feature less breeze than the planing conditions we get here in Northern California," Woolery said. "The planing verses non-planing attributes of the 50-plus footers become an issue for the equity in IRC. When racing in all kinds of wind conditions over this past year against the typical IRC boat — the racer/cruiser, the medium displacement boat with legitimate headroom, a real head, a galley, berths, water tanks and so on — we had many occasions where places were determined by just a few, or 20 to 30 seconds — which is pretty close after two hours of racing. The results of this year's Big Boat Series show that all of the TP 52's, even the last-placed boat, corrected out ahead of anyone in our fleet. To make a good rating rule even better, there should be some accommodation to level the playing field, if combining all these types of boats together into an overall regatta format is the goal."

With so many great stories to tell, and not enough space, we were forced to make a difficult decision: run more awesome photos, or a blue box with tiny type inside, that essentially duplicates the body of the story? We chose the former, and hope you're happy. But if you want to see the full results, video and images from the '09 Rolex Big Boat Series, all you have to do is visit: www.big-boat-series.com.

latitude/rg

GO FASTER!

GET 'EASOMIZED'

***Congratulations to
Gerard Sheridan & the
crew of 'Tupelo Honey',
winners of IRC D.***

Rolex Big Boat Series IRC C Winners King 40 'Soozal'

Easom Racing & Rigging wants to thank Dan & Suzie Woolery for bringing us aboard *Soozal* for an incredible 2009 Racing Season. *Soozal* is an 'Easomized' production King 40. Starting with winning Key West, then winning the Miami Grand Prix, winning the Jamaica Race, and finally winning the SF IRC Championship, *Soozal* became the dominant 40-ft IRC boat in the world.

No other production King 40 or even custom 40-ft IRC boat could touch the record of this IRC champion. Clearly a first class operation from top to bottom, and Easom was proud to play a part. Want to go faster? Get 'Easomized' this winter!

Easom Racing and Rigging

www.easomrigging.com

1150 Brickyard Cove Rd. Suite B1
Point Richmond, CA 94801

(510) 232-SAIL (7245)



SHARON GREEN PHOTO

REBIRTH OF *EROS* —

If you own a boat, you've undoubtedly got a project list. Because, as every sailor knows, doing maintenance and installing upgrades are inescapable aspects of boat ownership. Some of us, however, become embroiled in bigger projects than others. Take, for example, Bill and Grace Bodle, who, for the last 18 years, have been involved with a stem-to-



TOM BRICHTA

Wearing a full suit of sails, the newly completed 'Eros' glides effortlessly across the Bay during a recent shakedown cruise.

stern refit of *Eros*, a 103-ft (LOD) staysail schooner. With a mind-numbing list of rebuilds and upgrades now complete, they'll head out the Gate this month so that this 70-year-old thoroughbred can stretch her legs once again out on the open ocean.

To non-sailing observers *Eros*' acres of gleaming varnish, perfectly laid teak decks and the exquisite joinery of her cabinetry might simply appear to be cohesive elements of a floating museum piece. But fellow sailors have a deeper appreciation. From personal experience, they can imagine the endless hours of planning and meticulous handiwork — not to mention the money — that must have gone into this spectacular rebirth.

Experiencing this 1939 classic gliding

across the Bay with the easy motion of a bird in flight transports you to an era when hand-crafting fine yachts was truly an art. Indeed, at the end of a recent shakedown cruise, one enraptured guest thanked Grace profusely, saying with utmost sincerity, "Thank you so much. That sail was practically a religious experience."

Fine old boats with polished brass, flawless brightwork and traditional lines have that effect on some sailors. Bill and Grace succumbed to such old-school enticements way back in 1967, when they fell under the spell of their first big schooner, a 72-ft Gloucesterman named *Nordlys*, whose design was reminiscent of the famous Canadian yacht *Bluenose*. Then only 33 and 27 respectively, they took delivery of her at the St. Francis YC docks, and soon took off out the Golden Gate, bound for the sunny Caribbean.

By the time they got to Puerto Rico, though, their engine had quit, their sails were wearing out, and they were running out of cash. That's when they were introduced to the fledgling charter industry in the nearby Virgin Islands. *Nordlys* was soon one of the queens of the fleet. Long before futuristic megayachts ruled the roost in the international charter trade, elegant schooners were in high demand by well-heeled vacationers.

At the end of the first season, they crossed to the Med for the summer, establishing a pattern that they'd follow season after season. After chartering *Nordlys* for three years — including five transatlantic crossings — they bought a 98-ft schooner in Greece that they renamed *Grace*. Nine transatlantics later, they upgraded to a 117-ft schooner of a similar Alfred Mylne design, named *Panda*. Both boats were built of Burma teak by Camper and Nicholson.

By this time they'd built a devoted clientele who were eager to sail in different waters, so Bill and Grace set off on a three-year circumnavigation, doing charters along the way. In '82 they brought *Panda* to the Bay for a refit, then eventually took off again for the Caribbean. Their chartering days ended, however, when, in '84, *Panda* burned before their eyes in a

Martinique harbor. "After that," says Bill wistfully, "we came back to the Bay Area and swallowed the anchor."

Not long after their return, a friend encouraged Bill to take a look at Stone Boat Yard in Alameda, which was then for sale. He resisted the idea at first, but when he started poking around the historic yard with its vintage machinery, he was, as he puts it, "smitten," and bought the place.

This is where *Eros* comes into the picture. Then called *Fair Sarae*, she was



TOM BRICHTA

"Thank you so much. That sail was practically a religious experience."

AN 18-YEAR RE-FIT

eventually berthed at the yard, because her then-owner, Lucy Bancroft, was a distant relative of Bill's. In 1991 she sold the aging schooner to a German businessman named Christian Thesenfitz. Before taking a single voyage aboard her, he contracted with Stone Boat Yard to restore her to "as new" condition. From the beginning it was obvious that this would be no simple undertaking. But before we delve into the blow-by-blow account

Right: Cap'n Bill is one happy guy now that all the heavy lifting is done. Below: From stem to stern 'Eros' is a work of art.



LATITUDE / ANDY

of the refit, let's travel back to the late 1930s when this graceful schooner was built.

Back then, as Bill explains, it was normal practice in proper British society for rich and powerful people to own large, prestigious yachts. So it was fitting that after a wealthy American named Henry Von Berg married an English lord's daughter, he commissioned a renowned yard at the mouth of the Thames to build him a showpiece. Her designer was a prominent Scotsman named William McMeek.

Von Berg's attempt to score points with his in-laws — the White family



REBIRTH OF *EROS* —

— backfired dramatically, however, at the boat's formal christening. The story is that Lord White was renowned for his prized hounds, so Von Berg chose a name for his new yacht that he thought would surely honor both the family and his father-in-law's passion. When the drapery was pulled off the transom, the name was revealed: *White Bitch*.

Little did the American know, that it was considered exceedingly bad form to name a yacht after either one's family name or avocation. A second christening branded her with the name that she bore when launched, *Jeanry* (a safe amalgam of the multinational couple's first names: Jean and Henry.)

After *Jeanry* was returned to the White family in 1945, they soon sold her to a wealthy Greek named Stavros Niarchos, who named her *Eros* after the Greek god of love and passion. In the '50s he built the first supertankers, which soon made him a billionaire and earned him the nickname the Golden Greek. If boats could talk, we're sure *Eros* would have plenty of wild tales to tell about the Niarchos years. He was, after all, a billionaire contemporary — and business rival — of Aristotle Onassis, the flamboyant second husband of Jackie Kennedy.

When Bay Area socialite Lucy Bancroft bought *Eros*, she renamed her *Fair Sarae*, and brought her back home to the Bay Area. The fine old schooner was 52 years old when Lucy sold her to the German, Thesenfitz, in 1991. She had plenty of miles beneath her keel, although she'd never been around the world.

To understand the task of putting this vintage beauty into 'as new' condition, it's important to understand the way she is structured. She was built using "composite construction," which in the 1930s meant steel frames, floor beams and backing plates overlaid with Burma teak, and attached with Admiralty bronze fastenings. The British owned Burma back then, of course, and thus controlled the sole source of one of the only woods, if

not *the* only wood, that is impervious to worms and does not rot. A fascinating side note is that after British ships brought these prized teak logs to England, they were weighted down and sunk to the bottom of rivers to age for up to 40 years! So it's believed that *Eros*' original teak is over 100 years old.

In any case, after a thorough survey, it was determined that the boat's most challenging problem was substantial corrosion between the steel frames and the planking. And the only way to get at it was by gutting the interior, removing every plank, re-



LATITUDE / ANDY

A consummate hostess, Grace is looking forward to doing a bit of charter work again. That accidental profession was good to her.

conditioning the steel and putting the whole puzzle back together again.

Thesenfitz wanted the job done, so Bill soon had 30 men focused solely on the refit. Just removing the interior walls, cabinetry and furnishings was a colossal job, not to mention labeling every piece and finding a place to store it.

Once that was done, with the planking still on, the exposed steelwork was sandblasted, then triple epoxy coated. Next, 20,000 bronze fastenings had to be removed so the 3-inch-thick planks — which were in remarkably good condition after a half century of wear — could

Today, the refurbished main salon is almost identical to the way it was when this grand schooner was launched in 1939.



ZAC TURPIN

She was originally rigged as a "knockabout" schooner, meaning she had no bowsprit. But Bill wanted a broader foretriangle.

Unfortunately, Von Berg's bad luck didn't end with the naming incident. On the very first day of her first local cruise, *Jeanry* had no sooner anchored at the Isle of Wight when a British naval launch approached. An officer sternly gave Von Berg the incontestable news that the Navy was taking the vessel, then and there, for the war effort.

During the war years she served as a coastal patrol boat, and brought troops home to safety during the evacuation of Dunkirk. Meanwhile, Von Berg went back to the U.S., enlisted, and became a B24 fighter pilot. He died a hero over Germany like so many other brave young men.



TOM BRICHTA

AN 18-YEAR RE-FIT

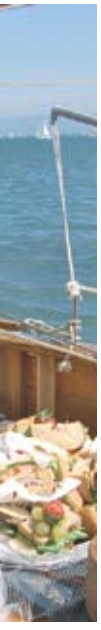

be removed piece by piece. On average, each plank is 38 feet long and weighs roughly 300 lbs, requiring at least four strong men to lift it into place. Needless to say, the higher up the hull they went, the more tedious the process became.

The work was slow, but was progressing well, when, after about a year the regular installment payments stopped coming from Germany. At that point the decks were still off, but the ribs had all been refurbished and about half of the planking was back on.

With 30 men on the refit team, Bill was more than a little concerned, and it wasn't long before he was on a plane to Hamburg to meet with Thesenfitz and find out what was up.

According to Bill, when he visited the German at his lovely estate, the two men initially shared small talk and a bottle of Dom Perignon. But when pressed about the unpaid bill, which had grown to roughly \$300,000, Thesenfitz told Bill he was tapped out, and simply couldn't continue the project. Not long after the meeting he flew out to the Bay with his surveyor, complimented the excellent work and signed the boat over to Bill. (They later learned Thesenfitz had been involved with some questionable dealings in Eastern Europe after the Berlin Wall came down, which eventually landed him in jail.)

"Grace was furious," Bill recalls. "She wanted nothing to do with it, and was convinced I'd somehow orchestrated the whole thing."

Taking possession of the old schooner was anything but a coup. In her disassembled condition she was virtually worthless, as it would clearly take a small fortune and countless man-hours to finish putting her back together again. Plus, she was taking up a huge section of

the boatyard.

"The whole thing became an embarrassment," admits Bill. "I was the one who'd taken her apart, and

I knew that if I didn't put her back together again, I would be the one who had ruined her." He was determined not to let that happen. But the 30-man

crew was immediately reduced to two, and when the yard got busy, even they were pulled away to work on more urgent projects.

Five years later, in 1997, *Fair Sarae* had been completely replanked and caulked, so she could finally be put back in the water, where additional work continued slowly.

At some point afterward, Bill and Grace decided to sell Stone Boat Yard, find a new home for *Eros* and finish her off as a retirement project.

In 2000 they found a buyer and used the money to develop a dilapidated stretch of waterfront on Richmond's Santa Fe Channel, across from KKMI. The

"Grace was furious," Bill recalls. "She wanted nothing to do with it."

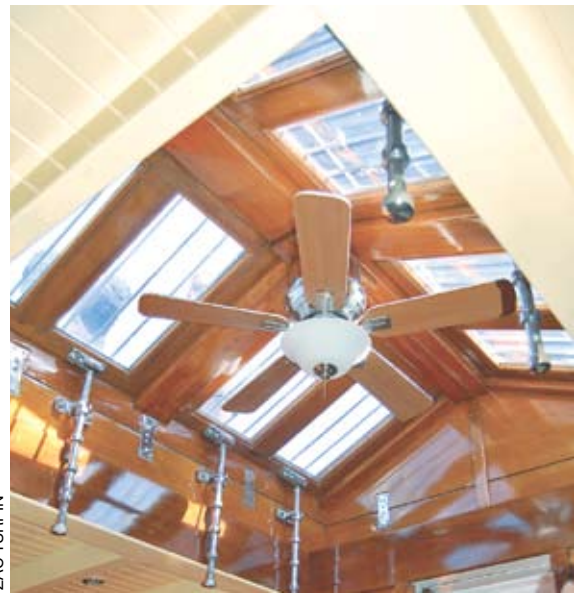

Called butterfly hatches due to their look when opened, each section can be lifted independently, with a choice of height adjustments.

happy memories.

Niarchos undoubtedly kept the boat well maintained, but there were a few things he did to her that Bill detested, such as installing a sunken cockpit aft, and an "ugly" oversized deck house that blocked the helmsman's view.

So when the decks were put back together, these pieces were eliminated. In their place, Bill and a small crew installed an elegant deck-level cockpit and dining table, and a smaller house that melds perfectly with the other deck features. These and two sets of classic butterfly hatches were put together with old-style mortise and tenon construction, and not a single fastening. Some of the wood for these elements was salvaged, but a lot of it came from a serendipitous deal Bill made

years ago to buy an entire container full of Burma teak.

When he knew her in Greece, Bill always thought *Eros* could use a bit more canvas, so he extended her mainmast by 20 feet, which created a bigger slot for a fisherman to be flown above the main stays'l. He also added a 17-ft bowsprit, where there had been none before.

Although you'd never know it, many of the bronze winches are now powered — Bill claims three people can run the whole boat in a pinch.

When we toured the hull two years



The new deckhouse and hatches were all put together without a single metal fastening. New gratings were made to match the originals.

Sugar Dock — so named because C&H Sugar vessels used to berth there — became the ol' schooner's new home.

Lying beneath massive fabric-covered arches that resembled Conestoga wagons from a distance, the long-disassembled classic slowly became whole again. Bill and Grace chose to rename her *Eros* because they had often come across her in the Med during the Niarchos years, an era that still brings back



REBIRTH OF *EROS*

ago there wasn't a stick of cabinetry or a single wall section below decks, other than the four watertight bulkheads. Today, though, there are four elegant double cabins, each with a private head, and one even has a Jacuzzi. The main salon is said to be exactly the same as when Von Berg first stepped aboard 70 years ago — except for the piano. Grace sewed all the cushion coverings and other fabric accessories herself.

Accommodations for six crew are found forward of a thoroughly modern galley, which Grace designed. In their early days of chartering, she attended a Cordon Bleu cooking school in the south of France and still loves to whip up exquisite dishes for dinner guests. And yes, the boat also has a washer-dryer these days.

"She's actually got most of the modern electrical stuff now," Bill confides, you just don't see most of it.

In addition to her 350hp Detroit diesel, she has a bow thruster — which



LATITUDE / ANDY

There's plenty of load on the primary winches when sailing in 20 knots on the Central Bay. But most winches now have a powered option.

is a godsend when docking — and two modern generators for auxiliary power.

Bill reinstalled the helm in its original position, aft, and it can now be bypassed in order to use an autopilot that

is controlled from the helm with a discreet joystick. An integrated chart plotter is also part of the helm station now, complete with AIS.

Why does *Eros* need such state-of-the-art equipment? Because now that they've *finally* got her all together, Grace and Bill plan to do a bit of voyaging. Where? When they tell us that they really don't know, we believe them, but for now she'll most likely remain on the West Coast. "We'll probably do some chartering too," says Grace. And why not. They've certainly got the boat for it.

It's nice to think that 42 years after heading out the Gate with their first big schooner, this salty couple will soon be slicing through the wavetops again, and creating new memories to replace those that have faded. We just hope that between *Eros'* stints of traveling she'll continue to call the Bay Area home.

— latitude/andy

COVER CRAFT

Make your boat
**DRY,
COMFORTABLE
& ROOMY**

with a dodger from Cover Craft



All sewing in Tenara thread

"Bringing the boat to you was the best investment we've made in a long time."

1230 Brickyard Cove Road, #106
Pt. Richmond, CA 94801
In Brickyard Cove Marina

(510) 234-4400

Quality
Yacht
Canvas

LIFELINE
...the heart of your system

Crafted for quality in the U.S.A.

MARINE BATTERIES

The original AGM manufacturers for the Marine and RV Industry

Sealed, Pressure Relief Safety Valves
Operates in any orientation without leaking. Maintenance-free; never requires water additions.

Lifting Handles
Easier handling, carrying & installation.

Copper Alloy Terminals
Provides low resistance electrical connection (copper-to-copper), non-corrosive, increased environmental protection & personal safety — no exposed lead.

Cover-To-Container Seal
Strong, epoxied tongue & groove cover/container seal will not separate even under extreme temperature & pressure changes or vibration.

Reinforced Copolymer Polypropylene Container & Cover
High impact resistance and resists bulging even under severe overcharge and temperature.

Intercell Connections
Massive "over-the-partition" weld increases the weld strength & provides low resistance connection path.

Absorbent Glass Mat (AGM) Separator
Custom designed and manufactured to provide superior wicking characteristics for electrolyte retention.

Thick Plates and High Density Oxide Paste Materials
Insures long life, excellent cycling capability.

Polyethylene Envelope
Eliminates internal shorts caused by shock, vibration & dendrite growth.

To learn more about Lifeline Batteries contact us or visit our web site at:

LIFELINE BATTERIES, INC.
955 Todd Ave.,
Azusa, CA 91702
800-527-3224
<http://www.lifelinebatteries.com>

Lifeline, a pioneer in AGM technology was originally developed in 1985 for military aircraft. Lifeline series of maintenance free deep cycle batteries that has been the leading AGM battery in the Marine and Motor Coach Industry for the past 15 years.

LOCH LOMOND MARINA

**MOVE-IN
SPECIAL:
FIRST MONTH
FREE!**

**Completely Rebuilt Marina • Gas & Diesel Fuel Dock
Free Pump Out Station • Modern Launch Ramp
Guest Slips Available • Marine Mechanical Boat Repair
Arena Marine Supply Store • Loch Lomond Market**

110 Loch Lomond Drive, San Rafael, CA 94901

Phone: (415) 454-7228 • Fax: (415) 454-6154

www.lochlomondmarina.com

Harbor Master – Pat Lopez • pat@lochlomondmarina.com



OYSTER POINT Marina/Park



*A full service marina located in
South San Francisco with berthing
and guest dockage available*

For information and pricing call

(650) 952-0808

www.smharbor.com/oysterpoint



MARINE INSURANCE SPECIALISTS

*Your best source for Yacht and Boat Insurance
tailored to your needs and competitively priced*

We Insure:

Sail or Power ♦ Classic or Contemporary
Fiberglass ♦ Aluminum ♦ Steel ♦ Wood

At Heritage Marine Insurance you will find knowledgeable
insurance professionals who provide the best service
and the finest coverage available today.

Please contact us for a quote

www.heritagemarineinsurance.com

800-959-3047

Fax 860-572-5919

Email: classics@heritagemarineinsurance.com

IDIOT'S GUIDE

Despite several advances in off-shore voice communications such as satphones, marine single sideband (SSB) isn't going away anytime soon. That's because SSB, unlike satphones, allows an unlimited number of people to listen to a transmission at the same time.

As such, SSB is the only way to go for the various regional cruising nets,

For cruisers in California and Mexico, you'll almost exclusively use just five of them: 4A, 4B, 4C, 8A and 8B.

such as the Baja, Sonrisa, Chubasco and Southbound. It means that when Don Anderson of *Summer Passage*, for example, transmits his latest weather forecast, anyone who wants to can listen at the same time. When someone has a question about the forecast, everyone can hear the question and Don's response.

Marine SSB is also perfect for cruising events such as the Baja Ha-Ha, the Caribbean 1500 and the Atlantic Rally for Cruisers. "While the Ha-Ha doesn't require SSB radio," advises the Grand Poobah, "most boats do have them. They're good for safety — but fun, too. The folks with SSBs are able to actively participate in all the roll calls, weather and fishing reports, and other fleet news. Over a period of nearly two weeks, personalities develop over the radio, and an even greater sense of community is established."

In racing events such as the TransPac, Pacific Cup, and Singlehanded TransPac, it offers more than just straight communication. "Thanks to marine SSB, our 1700 hour reports and discussions maintain the racing camaraderie and fun," notes Jack McGuire, KG6CJN, communications chairman of the '08 Pacific Cup race.

Although not the subject of this article, the other significant benefit of SSBs is that, when used with a Pactor modem and SailMail, they allow for the transmission and reception of short emails while offshore.

Licensing

You don't need to pass a Ham radio operator's test to use a marine SSB. All that's required is a valid Ship Station license and a lifetime Restricted Radiotelephone Operator's permit. No testing required! The Ship Station license is good for 10 years and is non-transferable. If you're good at dealing with online government forms, you can apply for a license at <http://wireless.fcc.gov>. If you're not so

good at it, or don't want to take the time, my lovely wife Suzie will be happy to help for a fee: (714) 549-5000.

How does Ham (amateur radio) differ from SSB? If you're new to long distance marine radio, I suggest not even worrying about it. Although I run the Radio School

and some of the income comes from teaching students how to use Ham radio

and pass the test, I generally discourage new SSB operators from taking that step right away. Get the no-test license for SSB radio, become familiar with the procedures and protocols, and use it for a few months. If you find that you're one of the very few cruisers who talks on the radio so much that SSB frequencies aren't adequate, then look into Ham radio. Or if you're going to the South Pacific, where there's lots more traffic on ship-to-ship channels, you might consider eventually moving up to Ham status. But generally speaking, it's really only for serious radio buffs.

By the way, there is nothing to prevent folks with SSB radios from listening on Ham frequencies, and indeed, there are some helpful Ham-only weather broadcasts. If you're worried that you might accidentally stumble onto a Ham-only frequency, start transmitting, and really piss off the 'radio police', fear not. SSB radios that are capable of working Ham frequencies come 'locked' from the fac-

How Far On What Bands?

A marine SSB system operates on a marine radio spectrum called shortwave, medium frequency and high frequency — 2 MHz-26 MHz. This radio spectrum is shared with hundreds of other radio users including shortwave broadcasts, Ham radio, FEMA, the American Red Cross and long-range aircraft.

Radio signals within the SSB shortwave spectrum refract off the ionosphere and come back to earth hundreds or thousands of miles away without the need for communication satellites and/or ground stations. Each marine SSB radio frequency band has a very predictable skywave bounce bulls-eye. If you choose a band that's too high, your signal will skip over the other station. If you choose a frequency that's too low, your signal won't go far enough to reach.

The following is a good guide for choosing the band of frequencies that will target your first skywave bounce:

2 MHz	200-400 miles
4 MHz	400-600 miles
6 MHz	600-1,200 miles
8 MHz	800-1,600 miles
12 MHz	1,200-2,400 miles
16 MHz	1,600-3,200 miles
22 MHz	2,200-4,000 miles plus
26 MHz	unpredictable during our solar cycle minimum

Pop Quiz #1: You are in San Francisco and you want to talk with your buddy who's on his boat 1,200 miles away in Cabo San Lucas. Which band on marine



In the realm of cruising, an SSB radio is a lifeline, an email gateway, and a hub of friendly conversation, like an old-fashioned party line.

tory. Some can only be unlocked using software, while others can be unlocked by simply pressing three keys at the same time. In cases of genuine emergencies, Ham frequencies can be used even by people who don't have a license.

SSB might you choose?

Answer: Because 4, 6, and 8 MHz would likely fall short on the first radio signal bounce, 12 MHz and 16 MHz would likely be your best choices.

The thing that usually drives new SSB operators nuts — and I know that it

still irritates the Ha-Ha's Grand Poobah — is that SSB radio frequency/channels are so different from VHF, FM, television and almost every other kind of channel. On VHF, for example, channel 72 is channel 72. On television, channel 7 is channel 7. What could be more simple?

Certainly not SSB radio. Get this: while 4146 is always 4146 on SSB, it's also known as 4A, and sometimes the designator 4-1. In addition, depending on the individual radio, it's often channel 35 or channel 77, and could also be some other channel. That's right, depending on what radio you bought and when, and who might have customized the user channels, channel 35 and channel 77 may or may not be 4146 and vice versa. And, of course, it might also be channel 63 or 147 — or a bunch of other channels.

The best way to get to 4146 is to just tune to 4146. The problem is that you may have to do a lot of knob turning, which can be annoying. In order to eliminate unnecessary wrist injuries from knob turning, some manufacturers 'channelized' the more popular frequencies. That is, they assigned specific channels to specific frequencies. For example, the Icom SSB radios of several years ago assigned channel 35 to frequency 4146 (aka 4A and 4-1). Unfortunately, in later radios, they decided to assign channel 77 to 4146 (aka 4A and 4-1). In addition, some retailers created custom 'user channel' packages, which gave yet another channel designation to 4146.

How did it all come to this? SSB operators used to have to spin the frequency knob like crazy to find anyone because there are more than 1,000 SSB frequencies — only a very few of which will ultimately be of interest to you. (More on that later.) As a result, most modern marine SSB transceivers — a fancy name for a combined transmitter and receiver in one black box — have nearly 700 pre-stored duplex channels (specific frequencies designated as channels for easier access). After all, what's easier: dialing through 1,000+ frequencies or 700 channels?

Nonetheless, you could spin your SSB dial all day long and you'd probably still hear nothing — except for WLO, the excellent radiotelephone station located in Mobile, Alabama. If you want to pick up something, look for on-the-hour weather and traffic reports on the following International Telecommunications Union (ITU) three- and four-digit designators: 405, 417, 805, 824, 830, 1209, 1212, 1226, 1607, 1624, 1641, 1807, 2237

and 2503. If you punch in 1607 on the hour, you'll get traffic lists and weather broadcasts from powerful WLO. The U.S. Coast Guard also broadcasts voice weather reports on ITU channels 424, 601, 816, 1205, and 1625.

Because SSB radios are more complicated than VHF radios, you might initially have a little trouble punching in the three- and four-digit ITU channels and/or the actual frequencies.

Icom America, Furuno, and SEA are the last remaining SSB manufacturers, and of the three, Icom is the undisputed leader when it comes to equipping recreational vessels with marine SSB gear. To help North American sailors more easily call up relevant ship-to-ship, Coast Guard, weather facsimile, Ham and marine telephone stations, Icom has pre-programmed 160 "favorite channels" — channels 1 through 160 — into a memory circuit titled 'User Channels'.

If you have an Icom 802 and tune

to Channel 77, you'll find that you'll be on frequency 4146 (aka 4A). And if you tune to Channel 118 on an 802, you'll find yourself on frequency 3968, which is home to the Sonrisa Net at 7 a.m. Pacific Time in the winter. It will even show 'Sonrisa Net' on your screen, even though the Sonrisa Net only uses that frequency a few hours each day.

Your radio will no doubt also have a toggle for 'channel/frequency'. As you move it, the display will switch back and forth from, say frequency 4146 to Channel 77 — assuming, of course, that 77 has been assigned to 4146 on your particular radio.

Most Icom marine SSBs may be tuned off of a memorized channel, to hear a weather report on a frequency that has recently moved. Press the 'CL' button — the channel knob now goes into frequency changing — and turn the knob in tiny steps. You may need to do a lot of knob twirling to get to some of the new weather nets. Be sure to push 'CL' again to get out of this mode.

Take this opportunity to run all the user channels on your radio, and make

Latitude 38's Easy Guide to Mexico Nets

Baja California & Mainland Mexico

Daylight Savings Time Schedule (Summer)

Time				Latest ICOM Channel	Freq kHz Pri / Sec	Upper/Lower Sideband	Net Name
UTC (GMT)	PDT W. Coast US	MDT Cabo, LAP	CDT PVR, ACA				
*** Marine SSB Nets ***							
0:30	17:30	18:30	19:30	92	6224	USB	Southbound Net
14:00	7:00	8:00	9:00	105	8122/8116	USB	Amigo Net
N/A	N/A	N/A	N/A	95	6516	USB	Bluewater Net
*** Listen-Only Ham Nets ***							
14:30	7:30	8:30	9:30	149	7192	LSB	Chubasco Net*
15:00	8:00	9:00	10:00	141	7233.5	LSB	Baja Net
19:00	12:00	13:00	14:00	156	14340	USB	Mañana Net*
19:00	12:00	13:00	14:00	151	14300	USB	Pacific Seafarer Net
14:00	7:00	8:00	9:00	135	3968	LSB	Sonrisa Net

* NOTE: Net warm-up and coordination sessions frequently begin prior to the published net opening time.

Standard Time Schedule (Winter)

Time				Latest ICOM Channel	Freq kHz Pri / Sec	Upper/Lower Sideband	Net Name
UTC (GMT)	PDT W. Coast US	MDT Cabo, LAP	CDT PVR, ACA				
*** Marine SSB Nets ***							
0:30	16:30	17:30	18:30	92	6224	USB	Southbound Net
14:00	6:00	7:00	8:00	105	8122/8116	USB	Amigo Net
N/A	N/A	N/A	N/A	95	6516	USB	Bluewater Net
*** Listen-Only Ham Nets ***							
15:30	7:30	8:30	9:30	149	7192	LSB	Chubasco Net*
16:00	8:00	9:00	10:00	141	7233.5	LSB	Baja Net
19:00	11:00	12:00	13:00	156	14340	USB	Manana Net*
19:00	11:00	12:00	13:00	151	14300	USB	Pacific Seafarer Net
15:00	7:00	8:00	9:00	135	3968	LSB	Sonrisa Net

* NOTE: Net warm-up and coordination sessions frequently begin prior to the published net opening time.

Time adapted from Docksideradio: www.docksideradio.com

IDIOT'S GUIDE

a list of what frequencies/stations they refer to. As mentioned, if you have a newer Icom 802, it's very likely, but not certain, that you have the same channel/frequency combinations as owners of other new Icom 802s. But if you have an older Icom model, or perhaps had a custom user channel package installed into your 802, I'd recommend that you have an authorized Icom dealer come down and give you the most recent user channel package. He'll just plug his

San Francisco, New Orleans, Miami and Norfolk.

Warning! Remember, different bands have different ranges. If you make an emergency call on 2182 when you're halfway between Mexico and the Marquesas, it's very unlikely anyone will hear you. If you check the earlier chart, you'll see that you'd actually want to transmit on 12,290 (12S) where the range would be 1,200 to 2,400 miles.

Radio signals within the SSB shortwave spectrum refract off the ionosphere and come back to earth hundreds to thousands of miles away without the need for communication satellites and/or ground stations.

computer into the front of your radio and download the new stuff. It shouldn't take more than 15 minutes, and will sync you with the majority of other SSB radios.

If you look at the sidebar, you'll see *Latitude 38's* favorite SSB channels that will help you better understand that each channel has a specific purpose. You'll notice there aren't 700 of them. That's because you can use only 33 primary channels. And for cruisers in California and Mexico, you'll almost certainly use just five of them: 4A, 4B, 4C, 8A and 8B. That's not many, but you'll rarely have trouble finding an open channel. (There are an additional 49 secondary channel/frequencies on the 4 MHz and 8 MHz bands that you can use if they aren't being used at the time, but if you're just starting out, you don't need that additional confusion.)

The main thing to do is play with your user channels/frequency combinations so you become familiar with them. It won't take long. If you find that your channels are out of sync with most other folks' SSBs, you might want to change yours to match theirs. Depending on how technical you are, you may or may not need assistance.

Calling For Help Over The SSB

There are six Coast Guard Global Maritime Distress and Safety System (GMDSS) channels/frequencies: 2182, the distress channel; 4125 (4S); 6215 (6S); 8291 (8S), 12,290 (12S); 16,420 (16S). The Coast Guard and other international rescue agencies monitor them 24 hours a day. U.S. Coast Guard monitors out of Hawaii, Guam, Alaska,

Checking Your SSB Reception And Transmission

As a new user, even if you get some meaningful reception as you dial around the channels, you'll probably still wonder if your SSB is working as it should. One way to find out is by trying to pick up the time signals at 10 and 15 MHz and WWV, which provide a continuous signal for a ready reference. If you're still at the dock and plugged in, you may find that turning off the shorepower battery charger will make a huge difference in your reception. Ditto for refrigeration, fluorescent lights and inverters.

If you're not sure that you're transmitting, you can tell a lot by looking at the LCD display on the face of your radio. First, push the 'TUNE' button, at which point the radio should briefly transmit a low power signal to tune the automatic antenna coupler. Do this on any 6 MHz channel as long as there is no traffic on it. The word 'TUNE' should flash a couple times on the LCD screen, and then stay up on the screen when the radio cycles back to receive. Still see the word 'TUNE'?

This is good. However, if the word 'THRU' comes up, or 'HI SWR', you've got problems. It's probably time to bring in a NMEA-qualified marine SSB specialist to find out what's wrong between your radio and your tuner.

Assuming you do get 'TUNE', it's

time to pick up the mic and try a short transmission. After doublechecking that the frequency is clear, key the mic, and speak directly into it saying "FOOO-OUUUUR." The mic should be touching your lips when you do this. If the following things happen, it suggests that your transmission is good and powerful:

- 1) The LCD bar graph goes full scale.
- 2) Your cabin lights dim slightly.
- 3) The instrument indicator lamps glow.
- 4) The bilge alarm squeaks.
- 5) The house battery drops about half a volt.

It's perfectly normal for instrument panel lights to glow and bilge alarms to squeak when a powerful 100 watts are coming out of your SSB. But be sure to doublecheck that the LCD transmit indicator shoots across the screen when you say a very loud "FOOOOUUUUR."

A potentially more dangerous way to test the transmit power output is with a small fluorescent tube at night. Ask your first mate to hold the glass tube against the insulated backstay antenna or the big white whip. *Caution! Be sure they don't touch the backstay with their fingers or other parts of their body, as this could result in a nasty burn or worse.* Say the magic word ("FOOOOUUUUR") once again, and the tube should instantly light up. The glass must actually be touching the radiating antenna or antenna lead-in single wire for this to happen.

If the cabin lights dim, the head flushes, numerous bilge alarms go off, and the fluorescent tube lights up, chances are excellent that you're putting out 100

watts. But are they clear watts? Only a radio test with another SSB user can determine that, so ask someone else in the marina to dial in a common ship-to-ship channel, such as 6224, and run your radio check. This will be a good test for a nice, clean signal.

If your test partner reports that

your sound was garbled, and you've just added a new email modem to your rig, temporarily disconnect the wire going from the back of your SSB to the computer. If your voice is now clear, these additional wires are the problem. Your local marine electronics specialist

Latitude 38's Favorite SSB Channels

When cruising Mexico, these are the only channels you'll really need for calling ship-to-ship or ship-to-California.

Channel Designator	Latest ICOM Downloadable Channel	Frequency kHz
4A	77	4146 kHz USB
4B	78	4149 kHz USB
8A	97	8294 kHz USB
8B	98	8297 kHz USB

carries snap-on filter chokes, which may resolve the garbled voice problem.

A good test for the range of your radio is with me! I'm happy to offer *Latitude* readers free, on-the-air radio checks on an appropriate SSB frequency that will agree with the approximate range between your station and mine here in the Newport Beach area. If your boat is in the Bay Area, we will likely use 8 MHz. If you are local, we'll go with 4 MHz, and if you're down in Cabo, we'll probably choose 12 MHz. Call me at (714) 549-5000 on weekdays and we'll find a nice quiet channel for our radio check.

Another great way to test your marine SSB transmit-and-receive capability is with weather guru Don Anderson on his marine SSB Amigo Net. He begins at 1415 hours Zulu (UTC) on 8.122.0 MHz, upper sideband. If you have the latest frequency load from Icom America, it's already stored in memory as channel 105. If you don't find it in memory, you will need to break out the instruction book and learn how to program a new frequency into your user-programmable

SSB in an Emergency

Marine SSB has been allocated hundreds of international channels, some of which are closely guarded by the U.S. Coast Guard and worldwide rescue agencies. They are prepared to act immediately on any received *mayday* or call for medical assistance. The Coast Guard maintains 24/7 distress radio guards on the following frequency bands:

2.182 MHz.....	0-400 miles
4.125 MHz.....	400-800 miles
6.215 MHz.....	600-1200 miles
8.291 MHz.....	800-1600 miles
12.290 MHz.....	1200-2400 miles
16.420 MHz.....	1600-3200 miles

frequency 'bin'. It's not hard, but if you've never done it before, it can be a mystery. You might want to call in a marine electronics tech familiar with marine SSB equipment. Try Don Melcher of HF Radio On Board (Alameda) at (510) 814-8888; Shea Weston of Offshore Outfitters (San Diego) at (619) 225-5690; Steve Helms of Marine Radio Consultants (San Diego) at (619) 276-5530; Ron Romaine of KKMI (Richmond) at ron@kkmi.com. Or me.

I've got two final tips.

First, if you sent your Icom 802 to the factory to get the 'clipping' problem fixed, you'll note that there are two places to plug in the antenna. One is for the DSC antenna, the other for your SSB antenna. Unfortunately, they are not clearly labeled, and a number of people have plugged their SSB antenna into the wrong port. As a result, transmit and receive range are minimal. You'll see an antenna tuner error if plugged into the wrong jack. Set it up temporarily and test it with time signals.

Second, to avoid violating FCC rules, Icom is very conservative regarding output power and how wide the signals are. I think they're too conservative. If you get that voice compression software unlocked, your radio transmissions will boom out with a commanding signal like Voice of America. The software upload is available only from authorized Icom dealers. They can come aboard and plug it into your radio, as well as the most recent 'user channel' update. It usually takes just 15 minutes.

— *gordon west*

SCHOONMAKER POINT MARINA

• IN SAUSALITO •



Call the Marina Office
for more information

415•331•5550

FAX 415•331•8523

or check our web site at
www.schoonmakermarina.com

85 LIBERTY SHIP WAY, #205
SAUSALITO, CA 94965



160 Berth Marina in one of the most beautiful spots on the Bay

- Visitor berths • Guest moorage able to handle yachts up to 200 ft.
- Dry storage • Waterfront Offices • Three-ton Hoist • Windsurfing
- Deli • Beach • Rowing • Kayaking • Yacht clubs always welcome

THE GREAT SCHOONER RACE

Sixteen schooners in two divisions turned out August 29 for the San Francisco YC's Great Schooner Race. With participation up 40% over last year and some of the Bay's most notable schooners — some old, some new — in attendance, the Great Schooner Race was exactly that. The after-sail party featured live music and a cameo appearance by *Latitude 38* Managing Editor "Banjo Andy" Turpin, and perhaps the best of all, an artfully managed raft-up of all the boats on proud display.

Don't be tempted into thinking this was some kind of boat parade, a 'con-cours d'museum pieces.' Many, if not all, of these boats are actively sailed and, on that day, sailed hard. With breeze into the low 20s, the pursuit race saw the Marconi division do a Bay tour — Yellow Bluff-Cityfront-Blossom-Southampton Shoal-Marker#4-finish at the club — while the gaffers did all but the Yellow Bluff leg.

Bob Vespa's Edson Schock-designed *Scorpio* beat all comers in the Marconi division. At 42 feet on deck, the boat has been around since it was christened for a movie director — a silent movie director — in 1927. Vespa purchased *Scorpio* in 1994 during a standstill in an ongoing restoration; it would be 10 more years before she sailed again. He credits the boat with getting him to retire from the faculty of City College of San Francisco, where he taught commercial photography from 1971 to 1996.

"This was about the fourth boat race I've ever entered," Vespa said.

"So I worked the decks, and deferred the strategy to a seasoned crew."

His decision to let Dave Rempe, Bill Vespa, Mark Lindlaw and Justin Ward take care of the strategy paid off.

"It seemed we'd never catch *Tillicum I*, who stayed ahead of the pack forever," Vespa said. "It was seesaw from Blossom Rock to Southampton Shoal, with *Scorpio* staying barely ahead of the last of the pack on the downwind side. *Tillicum* decided to sail higher into the falling wind and, I believe, got into some of Angel Island's wind shadow, and dropping in with us.

"We approached Southampton in a tight pack. After rounding it, we dropped to the back of the pack and headed a bit more to weather, but when we were about even with the last of them, the wind all but died.

"Though we were all ghosting along at a barely navigable speed, we began inching ahead of the pack as the breeze backed a bit to the south, and they fell into our wind shadow. At that point, we could see *Elizabeth Muir* joining the pack, and then *Santana* — but they both came to the same halt about the time we began to see the whitecaps forming up ahead. We threw up a small fisherman in anticipation of moderate winds to the finish, rounded Marker #4, and dropped the genoa jib in favor of a yankee jib and fore-staysail for the beat up Raccoon Strait."

Jeff Hawkins' *Jakatan* — the newest boat in the fleet — beat six other gaffers.



LATITUDE/ROB



LATITUDE/ROB



LATITUDE/ROB

— GETS EVEN BETTER



Clockwise from above — 'Elizabeth Muir' with a bone in her teeth as she reaches across the Slot; who says only plastic-boat racers get to wear matching crew gear; Raccoon Strait was a pretty busy place as the fleet compressed before their finish; 'Gaslight' rumbles along in the Central Bay.



LATITUDE/ROB



THE GREAT SCHOONER RACE



JAKATAN



LATTITUDE/ROB



BEN BOROK

From left — Jeff Hawkins; a study in contrast as Hawkins' green-hulled 'Jakatan' — the new boat with the older style of rig — and 'Scorpio' — the older boat with the newer rig style — cross tacks in Raccoon Strait; Bob Vespa.

Hawkins sailed his two-year-old, Bob Perry-designed boat to a solid win. Built by Jespersen Boat Builders in Sidney, B.C., the Sausalito-based *Jakatan* is the product of not only a talented builder and designer, but also an owner who's designed some notable things himself.

Hawkins was one of the co-founders of Palm — as in, the Palm Pilot — yet the man who designs electronic gadgets

went to great lengths to keep them out of the cockpit of his 40-footer, limiting his displays to only a speedo, autopilot control and depth sounder.

"I'd wanted to own a gaff-rigged schooner for many years," Hawkins said. "But I wanted one with modern accommodations, that I could sail singlehanded. I would

like to race the boat more; this was a great way to gently get back into it as I hadn't raced since I was in college."

Sailing with Hawkins were wife Janet Strauss, Dennis Boyle, Peggy Burke, Ken Feehan, and Ed Colligan.

"We all had a blast," Hawkins said. "The raft-up at the club after the race was the best. The schooners are beautiful and each has an interesting history. I would encourage anyone to visit the boats after next year's race."

latitude/rg

STAY FOCUSED WITH OUR EYE SAFE NO-STING FORMULA



Z Blok sunscreen's new non-greasy formula will not burn or irritate your eyes. So you can concentrate on winning the race or just enjoying a great day on the water. Z Blok is also fragrance free.

Z Blok is the official sunscreen of the PUMA Ocean Racing Team. Skipper Kenny Read said:

"The UV protection is excellent. Every member of the team is a true believer. We have put Z Blok to a tough test that few others can. Most importantly, we have experienced no eye stinging or irritation and we use it every day."

Visit zbloksun.com or call 508.995.9511

OFFICIAL SUNBLOCK OF THE PUMA OCEAN RACING TEAM

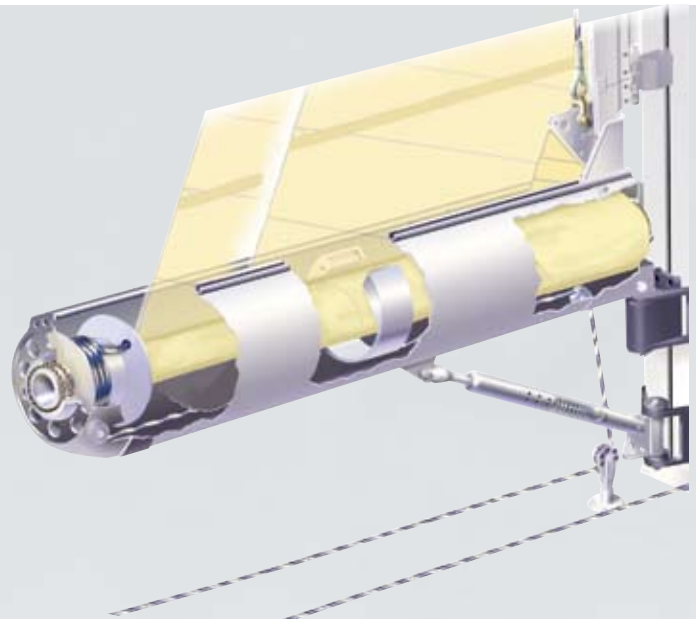

FURL ON THE FLY.

With Schaefer's innovative boom furling system and patented articulating sail track, you can reef your main on any point of sail - all from the safety of the cockpit. Trouble free reefing and furling - just what you would expect from Schaefer Marine.

SCHAEFER
LEGENDARY STRENGTH

508.995.9511
SCHAEFERMARINE.COM

BERKELEY MARINA



Centrally located off Hwy. 80 at University Ave. • Fast Access to the Central Bay • Fuel Dock • Marine Center with 35 Ton Lift Capacity • Launch Ramp • Waterfront Hotel • Restaurants • Adventure Playground • 17 Acre Off-leash Dog Park • Picnic Sites • Deli and More...

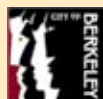

CITY OF BERKELEY
PARKS RECREATION AND WATERFRONT

Berkeley Marina Office
201 University Ave. • 510-981-6740

Visit our website at: www.ci.berkeley.ca.us/marina

NEW

**The Most Reliable
Power for Cruisers!**

ULTIMATE POWER MANAGEMENT



victron energy

3000W True Sine Wave Inverter
120Amp Four Stage Adaptive Charger
Dual Battery Bank Charging

Dealer Inquiries Welcome



SWEDISH MARINE

1150 Brickyard Cove Rd., #B6, Pt. Richmond, CA 94801
(510) 234-9566 • info@swedishmarine.com



\$95K Ready to Sail

LOA	LWL	Beam	Draft	Displ.	Spar
27' 10"	25' 0"	7' 6"	6' 0"	4,073	Carbon

Introducing the LS-30 performance daysailer from The Landing School. Only two available annually.

landingschoolboats.com

207-985-7976

BAJA HA-HA PROFILES, PT II

One of the differences between veteran cruisers and first-timers is that newcomers actually think they'll complete all the tasks on their 'to do' lists before the date they've set for leaving town. Veteran cruisers know better.

That's why we're often told that the best thing about the annual Baja Ha-Ha rally is its concrete starting date, when, ready or not, even inveterate procrastinators are inspired to stow their fix-it lists, set their sails, and head south.

As you've undoubtedly heard, there are other good things about the Ha-Ha too, such as making friends with like-minded adventurers, communing with Mother Nature, and having a rare opportunity to reinvent yourself, if only during a brief getaway from the workaday world.

As reported in *Sightings*, this year's fleet has grown to record proportions, and as you'll read here, its 600+ participants have a wide variety of motivations for sailing south of the border this season.

Here then, is installment two of our profiles on the Baja Ha-Ha Class of 2009. (Boats are listed in the order in which they signed up.)

Echo — Islander Freeport 41

Michael Bereznoi, Beaverton, OR

Noteworthy: Michael eventually hopes to get to Borneo, the Philippines and

Chrokeva — CT54

The Pitts family, San Diego

Mark and Jackie point out that one of the most unusual things about their entry is that their 18-year-old daughter Amanda is actually excited about being on a boat with her parents for an extended period of time.



The 'Pitt crew' borrows a pose from 'Titanic'.

Doing the Ha-Ha is a huge step for each of them, as none has previously sailed more than 100 miles north or south of their San Diego homeport. After the rally they plan to saunter down to Panama, then cruise the Caribbean and beyond. "For the most part," says Mark, "we plan to just do whatever feels right. We have no plans to head back to the US anytime soon."

Indonesia for scuba diving.

En Fuego III — J/44

Bill & Hillary Cook, Quincy, CA

Quote: "You can see by all the nuts and bolts that this is a working boat!"

Jesse's Girl — Morgan 440

Jesse & Shanna Hibdon, Alameda

Noteworthy: In order to embrace the cruising life this couple sold not only their house, but also Shanna's lingerie shop!

Sceptre — J/130

Bob Musor, Alameda

Quote: "I have raced all over the world, but also enjoy cruising. I'm looking forward to a nice cruise down the Baja Coast with old friends, and I'm also looking forward to making lots of new friends."

No Name — Catalina 30

**Bob Bahlman & Margie Hewes
Sausalito**

Noteworthy: After the rally, Bob and Margie will head up to the Sea of Cortez for some kiteboarding.

Dragon's Toy — Island Packet 37

Tom Kohrs, Freeport, CA

Noteworthy: After doing two previous

Ha-Has, Tom plans to do the Pacific Puddle Jump in the spring.

Wayward Wind —

Alberg Odyssey 30

**John & Geri Conser
Newport Beach**

Noteworthy: John is a well-known catamaran designer/builder and Geri is a longtime marine photographer.

Qualchan — Whitby 42

The Pond family

Redondo Beach

Noteworthy: Margaret & Todd, aka Mom and Dad, are thrilled to be introducing their kids — Natalie, 16, Charlee, 8, and Luke, 7 — to the cruising lifestyle.

Southwind — Islander 36

Jean Gregory, Oceanside

Quote: "After meeting and listening to so many Ha-Ha'ers relate their adventures doing the HaHa, I can't



If you see a steer's head bearing down on you, you'll know that you are about to be passed by the highly experienced 'Seabird' crew.

wait to experience it for myself and have my own tales to tell."

Stella Blue — C&C Landfall 38

Wally Bryant, San Francisco

Noteworthy: This boat was a derelict in 2001. Wally has spent the last eight years rebuilding it — "new rig, new engine, every nut, bolt, wire and hose."

Campbells Sloop — Catalina 34

Susan & Don Campbell, Dana Point

Noteworthy: This boat is hull #1 of the Catalina 34 line; Don will be the only male among Cap'n Susan's otherwise all-girl crew.

Sea Dream — Jomar 55

**Ron Brimlow & David Dodrill
Long Beach**

Noteworthy: Ron and David both began sailing in the '60s, but on different coasts.

Allymar — Ingrid 38

Ken Gosling, Winchester Bay, OR

Quote: "Allymar is finally getting to

— HEADIN' SOUTH OF THE BORDER

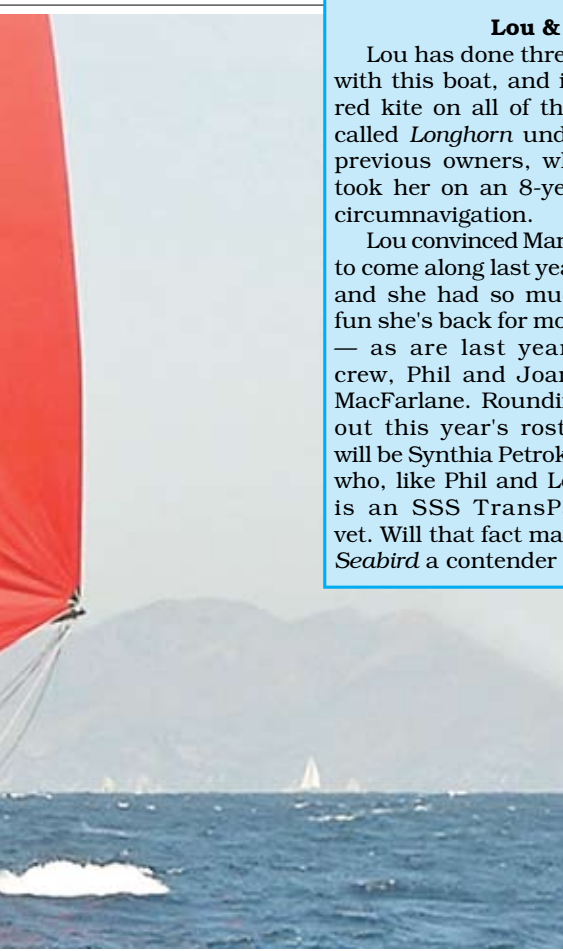

Seabird — Swan 51

Lou & Marge Freeman, San Diego

Lou has done three Singlehanded TransPacs and two Ha-Has with this boat, and if we're not mistaken, he's used that same red kite on all of them. Why the steer's head? This boat was called *Longhorn* under previous owners, who took her on an 8-year circumnavigation.

Lou convinced Marge to come along last year, and she had so much fun she's back for more — as are last year's crew, Phil and Joann MacFarlane. Rounding out this year's roster will be Synthia Petroka, who, like Phil and Lou is an SSS TransPac vet. Will that fact make *Seabird* a contender for



Lou and Marge — and their big red chute — are back again for more Ha-Ha fun.

class champion? Time will tell. father-son team, as *Joya* has life-sized, bare-breasted mermaids painted on both sides of her bow.

Scott Free — Gulfstar 44

Scott & Monica Stoner, Seattle, WA

Quote: "We plan to cruise in the Sea of Cortez until the Dow hits 14,000!"

Eupsychia — Cal 36

David Addleman, Monterey

Quote: "After a career in engineering, where details, planning and control were paramount, I enjoy the uncertainty of sailing."

Jabiroo — Island Packet 35

John & Janice Limb, Dover, OR

Noteworthy: John claims that he's had to replace almost every system on this boat since buying her 11 years ago.

Monitor — 55-ft Monk trawler

John Wilson, Coos Bay, OR

Noteworthy: According to John, "*Monitor* is a one-of-a-kind boat — one of Ed Monk, Sr.'s very first pleasure boats."

Old Moon — Hylas 49

John & Mary-Ann Cogan, Ventura

Quote: "We're slipping & sliding south to the land without a plan."

Raindancer — West Indies 38

Daniel Eastman Federal Way, WA

Noteworthy: Now retired, Daniel used to make his living as a locomotive engineer — that's a Ha-Ha first.

Harrier — Finn Flyer 31

Ken & Lou Roper, Los Angeles

Noteworthy: A retired brigadier general, Ken has done more Singlehanded

TransPacs than we can count. He'll have crew on the Ha-Ha, though: his daughter Lou.

Passage II — Hunter 410

Jim Cassidy & Lucy Lowe Channel Islands

Noteworthy: Jim and Lucy bought their first boat in 1988 and have sailed it almost every weekend, more often than not to the Channel Islands.

Sapphire — Hunter 30

Luke McDonald & Megan Buechler Portland, OR

Noteworthy: Luke: "We started sailing two-and-a-half years ago after an exciting dinner conversation about how we'd both like to sail around the world if we won the lottery." They didn't win a million, but managed to cut the docklines anyway.

Mahalo — Cal 40

Holly Scott, Long Beach

Noteworthy: Now an official cruising consultant for West Marine, Holly began her sailing career when she was three months old; she first took the helm at age three and got her first boat at 10.

Escapade — Catana 52 cat

Greg Dorland & Debra Macrorie Newport, OR

Quote: "We've learned to be flexible in our planning, but we'll possibly end up

Liberty — Nicholson 35

The Strattan-Candille family Redwood City

"We're doing the Ha-Ha," explains Seth.



"Enough of academia, let's go cruising!"

"because we're sick and tired of *preparing* to do the Ha-Ha." He and Sophie spent every weekend and every penny they had fixing up *Liberty* while they were graduate students at Stanford medical school. This cruise is their graduation present to themselves. (Both now have PhDs.)

Their 4-year-old crewman Casey will be in charge of beach sports on the way to Cabo.

do what she was designed for nearly 40 years ago. May the same be true for the captain and crew this year."

Tiger Beetle — N/M 45 IOR

Robert Macfarlane, San Francisco

Noteworthy: Although this is Rob's first Ha-Ha, he's no stranger to offshore sailing, having made five crossings to Hawaii.

Aquadesiac — Tayana V-42

Douglas Simms, Alameda

Quote: "As a young boy I always looked west when I was daydreaming. This journey is the culmination of those dreams."

Prevailing Wind —

Beneteau Oceanis 400

Peter Wragg & Natalie Pearl San Diego

Noteworthy: An Australian native, Peter's early sailing career took him across the notorious Bass Strait and Tasman Sea.

Joya — Dreadnought 32

Steve & Garrett Pruitt, Brookings, OR

Noteworthy: You can easily find this

BAJA HA-HA PROFILES, PT II

Little Lara — Pacific Seacraft 24 Jay & Peggy Bowden, Santa Barbara

Jay and Peggy tell us "Little Lara may not be the most expensive boat, she may not even be the largest boat, nor the fastest boat, but she is the happiest boat."



Who needs a huge cruising boat? A small, cozy space is better for snuggling.

We were glad to hear that, but 760 miles can be a long way in a 24-footer. Jay and Peggy seem to know what they're getting into, however. In fact they convinced the Rally Committee to bend the '27-ft minimum' rule. After the Ha-Ha, they'll cruise until spring, then "re-evaluate."

in the Caribbean, or Southeast Asia."

Adios — Columbia 43 Craig Shaw & Tiffany Lidy Portland, OR

Quote: Craig: "I'm really looking for-

ward to skippering *Adios* down the Baja with the kite up under the full moon! And with the best first mate on the planet, I'll have the biggest smile in the fleet!"

Prufrock — Santa Cruz 52 Jim & Diana Freeland Ko Olina, HI

Noteworthy: The Freelands have crewed on two previous Ha-Has aboard the three-masted schooner *Millenium Falcon*. This time that boat's owners will crew aboard *Prufrock*.

Albatross — Seamaster 46 Douglas Schneeman & JoDean Bifoss Marina del Rey

Quote: Doug: "This is hull number one. That's a good thing, right? My advice is: Never buy the first of anything. Let 'em work the bugs out first."

Bequia — Gulfstar 50 Richard & David Coleman

Richmond

Quote: "We've sailed the coast before, but it's been lonely. This sounds like a lot of fun!"

Espiritu Santi — Atlantic 57 Santiago Becerra, San Diego

Quote: "I'm ecstatic. I'm beside myself. I can already feel the warm breeze, hot sun, clear blue water — not to mention the cold beers and fish tacos. Mexico here I come!"

Aventura — Hunter 41 John Rollins, San Francisco

Quote: "Let's see what adventure each day brings."

Bluebird — Custom Trimaran 28 John Taylor, Lakewood, WA

Noteworthy: Built by John, *Bluebird's* unusual design and features make her a unique entry — and at age 88, her captain is one of the oldest and most experienced sailors ever to do the Ha-Ha.

Gypsy Blue — Beneteau 463 'Whitey' & Maxine White

Welcome to La Paz!



Join us for the
BAJA HA-HA BEACH PARTY
Thursday, November 19, 4-7 pm
at Papas & Beer Beach Club

All new hardwood docks
Dinghy landing with potable water
New protective piling & sheetpile breakwaters
Wireless Internet · and more!

Friendly, helpful, fully bilingual staff

TEL: 011 52 612 122 1646
email: marinalapaz@prodigy.net.mx
www.marinelapaz.com

Apdo. Postal 290, La Paz, 23000, Baja California Sur, Mexico

The Doctor Is In...

10 AM-2:00 PM on Saturdays



Ask us about our boat registration program: we keep your boat info on file so you can order parts from us while cruising Mexico and beyond.



If you have any electrical or electronic issues — or you'd like to make sure that your boat is sufficiently equipped for offshore cruising — please stop by for a free consultation.



Sausalito Marine
Electrical Shop "The Project Place"

300 Harbor Drive, Sausalito, CA 94965 (415) 332-9030

www.sausalitmarine.com - info@sausalitmarine.com

— HEADIN' SOUTH OF THE BORDER

San Francisco

Quote: Maxine "My first date with Whitey was sailing on San Francisco Bay on his Ericson 35. Our second date was spent varnishing."

Done Dealing — Beneteau 47 Jay & Gail Bryan, Lake Tahoe

Noteworthy: Jay once made a trip from Crescent City, CA, to Dutch Harbor, in Alaska's Aleutian Islands.

Tapestry — Command 10 tri Richard Pearsall, Ventura

Quote: "We're going to be dead a long time, so go cruising now!"

Sea Villa — Islander 37 Jim Morgan, Sausalito

Quote: "Sailing is truly an elemental experience that I enjoy immensely. I also very much appreciate the camaraderie of the sailing community. This seems like an excellent opportunity to combine the two."

Music — Beneteau 40 Rick Gio, Pt. Richmond

Noteworthy: Having begun his sail-

ing career in 1969, Rick already has lots of offshore sailing under his belt, including a sail from S.F. to Tahiti.

Osprey — Elan Impression 434 Jerry Whitfield Anacortes, WA

Noteworthy: Jerry's crew will be his daughter and son-in-law: Clair and Grant Burwash.

Paikea Mist — Beneteau 50 Michael & Gloria Hansmann Vancouver, BC

Noteworthy: Gloria met Michael in a college sailing class, where he was the instructor.

Chardonnay — Catalina 30 David Elkin, Richmond

Quote: "This isn't just another sail around the Bay!"

Odysseus — Maxi 97

William & Christy Hogarty, Pleasanton

When we asked William for a quotable quote, he replied, "Let's party." And believe us, this guy knows how to party in style, as evidenced by the Jacuzzi on his aft deck.



A veteran of two previous Ha-Has, his boats are always among the most impressive in the fleet: the Dynamique 80 *Leda* in 1998, and the N/M Able 94 *Marishiten* in 2001.

Odysseus will have a good-looking crew.

Apart from William's wife Christy, *Odysseus'* crew has yet to be announced. But we assume by the accompanying photo, that some junior sailors will be on the roster.

Mangareva — Dallimore 40 Mark & Gail Strong, Pollock Pines

Noteworthy: Mark and Gail met their

Welcome to La Paz
BAJA HA-HA
Beach Party at Papas & Beer
THURSDAY, NOVEMBER 19TH Beach Club

mexican folk dancing
live music by jurassic rock
food & drinks from 4-7 pm
door prizes and much more
free for first fifty
2009 baja ha-ha participants
everyone welcome

MARINA DE LA PAZ SAGREVY
VISTA CORAL marina estates
LA PAZ
www.visitlapaz.org
club panamar
MARINA COSTABAJA
CLUB DE YATES PALMIRA

BAJA HA-HA PROFILES, PT II

MoJo's Folly — Gemini 105Mc Cat John & Marie Orr, Napa

If boats could talk, this one would probably tell us she's thrilled that John and Marie bought her 18 months ago, as she spent her first few years in Stockton as a "dust collector" — a sad fate for any boat let alone one built for performance cruising like this one.

With Michael and Denise Eyton-Lloyd along as crew, John says, "We've got the right MoJo and good friends to accomplish a life long dream." After the rally they'll head up into the Sea of Cortez and play it by ear on an open-ended itinerary.



Marie raises her glass to the start of their long-anticipated cruise.

Dutch crew, Nico and Elyn, a few years ago in The Netherlands, as they own a similar European-built boat.

Jammin' — Freeport 41

James & Max Wilson Los Angeles

Quote: James: "I can tell by the way Jammin' dances on her bow lines that she's ready to get out of Dodge!"

Mariah — Seawind 1000 cat Gary Rufener, San Diego

Noteworthy: Like many of this year's participants, Gary plans to moor Mariah in La Paz for the season, then bash home in the spring.

Ohana — Sceptre 41 McKenzie-Palaska family Missoula, MT

Noteworthy: When Charlie and Beth got married, their prenup mandated that they would eventually go cruising with their family. With daughter Marina now 13, and son Keegan now 11, they're finally getting around to it.

Capaz — Perry 48 The Baker family, Seattle, WA

Noteworthy: Brad and PJ (dad and mom) will be "boat schooling" their sons Bryce, 11, and Austin, 8. One of the kids' tasks will be to produce a newspaper about their travels called the *Capaz Chronicle*.

Slow M Ocean — CHB 45 PH Trawler Errol & Norene Phillips, Scappoose, OR

Noteworthy: Errol and Norene started powerboating nearly 40 years ago.

Sagittaire — Brewer 47 Michael & Diane Quiriconi Seattle, WA

Quote: "Like Moitessier, we want to watch the sun set on the open sea, to inhale its breath, to let our land-bound cares evaporate before the immensity of the sea and sky, and to feel our joy soaring so high that nothing can disturb it."

IO — Davidson 44 R. & B. Kuschel, San Francisco

Noteworthy: This boat was designed by Laurie Davidson, of New Zealand A-Cup fame, and her first owner was



SPECIALISTS IN MARINE PAINT
AND FIBERGLASS WORKS

Services Include:

- Hydro-wash and Hull Cleaning
- Prep for Primary Painting Applications
- Hull and Bottom Painting
- Wood, Fiberglass and Blister Repairs
- Polishing and Waxing

Located at the new Escala Nautica Mazatlán
Tel.: +52 (669) 913-3946 or VHF Ch. 22
email: ccmarineservices@hotmail.com
www.ccmarineservices.com

MAZATLAN MEXICO

Made in the USA!



Got Shade?

PERFECT
FOR THE
HA-HA

- Ingenious, self-supporting awning system, attaches to lifelines
- Tall enough to walk under at cabin, no limbo
- Bombproof construction, easily sustains 25 knots
- Sets up in 10 minutes, stows complete in its own 10" x 36" bag
- 10 standard sizes fit any boat, catamarans too
- Prices from \$300.00 to \$700.00

Visit: www.intheshd.com

ShadeTree
888-684-3743
shadetree@gulftel.com

shadetree
Relax Under A ShadeTree

— HEADIN' SOUTH OF THE BORDER

renowned Kiwi racer Neville Crichton.

**Julia Morgan —
Morgan Out Island 41
Thomas Christensen, Long Beach**

Noteworthy: Thomas' experience should serve as a lesson to others: He had planned to cruise long-term. But after spending five years preparing this boat, he was diagnosed with pancreatic cancer, which means staying close to home for chemo treatments every two weeks. His doc, however, gave him a six-week reprieve to do the Ha-Ha.

**Talion — Gulfstar 50
Patsy Verhoeven
La Paz, Mexico**

Quote: "I'm going to sail all the way for the third time!"

**Sabbatical — Valiant 40
Phil Kumpis & Laurie Lipman
Hermosa Beach**

Noteworthy: The previous owners set out to circumnavigate, but got only as far as Tahiti due to health issues. Phil hopes to finish the trip for them.

**Eagle — Cal 35 Mk III
Phileta Riley &
Dorothy Tharsing
Bandon, OR**

Noteworthy: They just bought *Eagle* on August 5, and have been in a mad dash since then to get her ready for the October start.

**Lillia del Mar —
Catalina 400
Mark Slemmons
San Francisco**

Noteworthy: Mark began sailing in El Toros at age 8. He bought this boat, his fourth, just nine months ago.

**Alobar —
Island Packet 350**

Joel Ungar, Santa Barbara
Quote: "Viva la Baja Ha-Ha, viva Mexico, y vamonos amigos."

Albatross — Island Packet 32

The Foley family, Clear Lake Shores, TX

"Our plan," says Lisa, "is to sail home to Texas, but if



William, Tracy and Patricia are heading off again.

the cruising bug infects our sons — Teagan, 9, and Mick, 7 — and Captain Kevin can handle homeschooling, who knows?"

Both Kevin and Lisa have been sailing since they were pre-teens.

**Stepping Stone — Maple Leaf 42
The Anderson family, Newport, OR**

Noteworthy: Elias and Sarah say they've been dreaming of sailing around



Full Service Marina

- Offering a splendid combination of amenities such as:
- With up to 400 vessel capacity from 30 to 400 ft.
 - Pump out • Diesel and Gas fuel station • High quality and comfort in all slips • Power 110, 220 y 440 volts
 - Ship yard with Travel Lift up to 150 tons capacity • Restrooms • Showers • WiFi • Security 24/7
 - Restaurant (IKUAI) • Bar (TAIKAI) • Deli (KITSIUARI) • Yacht Club (ETUPA) • VIP lounge (business center) • Open air theatre (XIRIKI) • Electric cars transportation

www.marinarivieranayarit.com

info@marinarivieranayarit.com / Tel. (011.52) 329 295.5526 / MARINA COORDINATES: LAT. 20° 45'N / LON. 105° 24'W



BAJA HA-HA PROFILES, PT II

SOMF — Island Trader 46 **Jerry Wilhite, Stockton**

Quote: "This was my dream 25 years ago, but life and family buried it deep. Then five years ago it started to creep back into my dreams, and now here I am."

Some kids on Jerry's dock think SOMF looks like



Meet the 'SOMF' crew. Pirates? Naaah, we don't think so.

a pirate ship, but after seeing his shipmates' photo, we doubt that there's a buccaneer among them. What does SOMF stand for? That's a question you'll have to ask Jerry himself.

the world since they were kids. Now they're finally on their way — with their daughters, Kimberly, 16, and Savona, 5, along as crew.

Tsunamita — Hunter 356 **Kim & John Hartnett-Edwards** **San Diego**

Noteworthy: Kim and John both learned to sail in college, but this will be their first big offshore cruise.

Kells — Swan 44 Mk II **Jack Kavanaugh, Sausalito**

Noteworthy: Jack started sailing in '65. He's owned this 1976 Swan for 24 years.

Gitana — Cal 39 **Pat & Diane Mitchell** **South Lake Tahoe**

Quote: "After heading out the Golden Gate, we plan to turn left, check it all out slowly, and we may or may not come back!"

Nautilus — Passport 40 **Steven Ingham & Kristen Dean** **Centralia, WA**

Noteworthy: During the '80s Steven

sailed the Caribbean for six years on a previous boat. He rode out Hurricane Hugo at Puerto Rico's Culebra Island, where dozens of boats were driven ashore.

Tabu — Farr 44 **Sheri & Rich Crowe, Newport Beach**

Noteworthy: The fact that Sheri and Rich are sailing up from La Paz to do this year's Ha-Ha is impressive. But last year they sailed all the way up from Ecuador to do the '08 rally.

Bliss — Columbia 45 **Scott Brown & Lanie Peterson** **Helena, MT**

Quote: "Bitchin'! We can't wait to get started on this trip of a lifetime, and we're excited to make new friends and party!"

Lorien — Islander Bahama 30 **Ed Ammerman & Gina Sarbo** **San Francisco**

Quote: "Between my husband, a retired appliance repairman who was a diesel mechanic in the service, and myself,

TAKE A STEP BACK IN TIME

Enjoy a Cost-Effective
Private Charter
on the Yacht *EL DON*
in the Sea of Cortez near
Loreto Baja, Mexico

CALL
US TODAY
REGARDING OUR
SPECIAL HA-HA
PACKAGE



- Loreto is like Cabo was 30 years ago.
- Visit islands of Baja untouched by the hands of man, and marine life unchanged for thousands of years.
- Pristine beauty on an all-inclusive charter.

Contact Gary Noland (925) 623-8755
gmnoland@comcast.net

www.LoretoVacationPackage.com

IN SAN DIEGO

Sun Harbor

Your Green
Escape

World's First
LEED-Certified
Marina

SLIPS ★ OFFICES ★ LOCKERS

5000 N. Harbor Drive, San Diego, CA 92106

32° 43' 30" N / 117° 13' 31" W

(619) 222-1167 • www.sun-harbor.com

— HEADIN' SOUTH OF THE BORDER

an ER nurse with 26 years experience at a trauma center, we are set to fix things or people that get 'broke'."

Wave Goodbye — Hunter 44 Dan Redding, San Diego

Noteworthy: Dan bought this boat new in 2005 and did the '06 Ha-Ha as his first offshore shakedown cruise.

Saint Mary II — Catalina 34 Mk II Thomas Madden, Newport Beach

Noteworthy: This boat is named after Thomas' great uncle's fishing boat, which was the only vessel in an Irish fleet to survive a famous disaster at sea.

Rachel S — Cape George 40 Patrick Orleman, Waldron, WA

Quote: "My first boat was a wash tub in the pond next to my parents house."

Wizard — Choate 41 Obie & Mike Ciesiel, Portland, OR

Noteworthy: A prominent Portland businessman raced this boat for years. Some recent guests have sworn his ghost is still aboard!

Simple Pleasures — Freedom 36 Bernard Slabeck, Alameda

Quote: "I'll be leaving for good, for the second time!"



Bernard rides his masthead, safe from whale attacks.

Believe it or not his boat struck two different whales in two completely different areas of Mexico last year. They both swam away unharmed, but the second blow caused Bernard to bring his 36-footer home to Alameda for some keel repairs.

Coral Rose — Aloha 34 John Aldous, Beaverton, OR

Quote: "I live aboard *Coral Rose*, and I love the lifestyle it provides me."

Blue Lightning — New York 36 Michael Riley, Seattle, WA

Noteworthy: John says he decided to do the Ha-Ha because he was "very cold!" He first read about it in an old *Latitude* that someone had left in his marina's laundry.

Blue Swan — Ta Chiao 41 Robert Johnston, San Pedro

Quote: "Sounds like a great time! This will be the first of many new adventures."

J World — J/120 Wayne Zittel, SF/PV

Noteworthy: This entry is part of an instructional program. Her crew is made up of sailors with varying levels of experience, "from rookie cruisers to seasoned salts."

The Simple Choice For Fresh Water

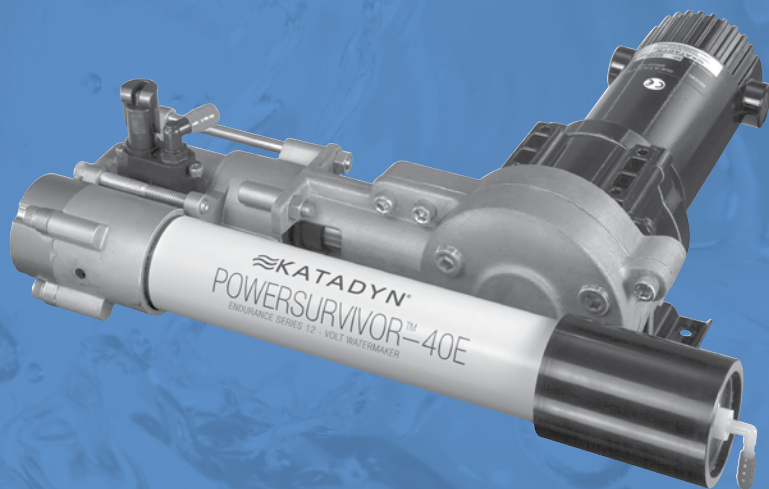

Katadyn PowerSurvivor Watermakers are small, reliable and easy to maintain. That's why they are the best selling watermakers for cruising sailors.

Making your own fresh drinking water is a great addition for the independent lifestyle. Katadyn watermakers are simple in design, moderately priced and have proven reliability.

For about \$3,400, it's a great way to improve life onboard.

800.755.6701 • www.katadyn.us

KATADYN
MAKING WATER DRINKING WATER

BAJA HA-HA PROFILES, PT II

Companera — Farr 44
Paul Eichen & Susan Flieder
Sausalito

Noteworthy: Paul and Susan convinced their Aussie friends, Annie and Bob, into join them on this cruise to the Cape.

Distant Drum — Beneteau 51
Harry Hazzard, San Diego

Noteworthy: This boat has done three previous Ha-Has. Not long after the '07 event, she survived a direct hit by lightning in San Blas.

Crescendo — Challenger 50 ketch
Bob & Alice Phillips, Olympia, WA

Noteworthy: Having cruised to Alaska and back three times, Bob and Alice are ready for a change of climate.

Puma — 52-ft power cat
Del Urban, Homer, AK

Noteworthy: Like most Alaskans, Del is obviously a do-it-yourselfer. He designed and built this power cat using composite (wood/epoxy) construction.

Willful Simplicity — Catalina 27
Steve & Charlotte Baker, Sausalito

"When we decided that there were more reasons why we must do the Ha-Ha than reasons why we couldn't, we were finally moved into action," explains Steve.



"Lookout Mexico, here we come."

That's impressive since Charlotte began sailing just a year ago. Steve, however, has been pulling strings and grinding winches for nearly two decades, so he undoubtedly set her on the 'fast track' to cruising.

Their 27-footer seems aptly named: "The most interesting thing about this boat is it's simplicity," says Steve. "It has taught us to live simply and love it."

Ludwig — Catalina 42
David Lott, Long Beach

Noteworthy: Dave says that doing the Ha-Ha has been on his 'bucket list'. But the most interesting thing about his entry is that, to join him on this cruise, he recruited a friend whom he's known since he was seven years old.

Symphony — Hans Christian 38T
Thomas Spencer & Magi Sarvimaki
Channel Islands

Noteworthy: Doing the Ha-Ha is actually Plan B for Thomas and Magi, as they'd originally intended to sail straight to Hawaii, but after making a boatload of new sailing friends, we'll bet they'll be glad that serendipity intervened.

We'll take a breather here, before our fingers fall off from too much pecking on the keyboard. But, believe it or not, you still haven't been introduced to the entire Ha-Ha XVI fleet. Look for a final installment in the November issue, then a complete recap report in December.

— **latitude/andy**

BAJA HA-HA SPECIAL

Stay in our marina for 7 days and get

3 FREE DAYS

MOORAGE



MARINA MAZATLÁN:

MÉXICO'S

NEW "HOME PORT"

MEXICO'S BIGGEST YACHT HARBOR KEEPS GETTING BETTER. THE NEW SINGLAR DOCK YARD FACILITY IS NOW OPEN HERE IN OUR SECURE HARBOR. MAZATLAN OFFERS SUPERIOR MARINE SERVICES, REPAIRS, RESTAURANTS, SUN, FUN, BEACHES... AND A GREAT CRUISING COMMUNITY. MEGA YATCH'S NEW DOCK 220 V 100 A.

2010 WINTER CRUISING RATES:
 NOV. 1 2009. THRU MAY 31 2010.

SIZE OF BOAT	0' TO 41'	42' TO 60'	61' TO 90'	90' OVER
TIME OF STAY				
01 TO 10 DAYS	\$ 0.95	\$ 1.10	\$ 1.40	\$ 1.80
11 TO 29 DAYS	\$ 0.60	\$ 0.70	\$ 1.00	\$ 1.30
30 TO 90 DAYS	\$ 0.43	\$ 0.61	\$ 0.70	\$ 1.00
91 DAYS OR MORE	\$ 0.36	\$ 0.43	\$ 0.50	\$ 0.60

RATES, IN U.S. DOLLARS, ARE BASED ON DOCUMENTED LENGTH AND DO NOT INCLUDE 15% TAX. 30 FOOT MINIMUM CHARGE.





MARINA MAZATLAN'S

"THANKSGIVING"

DINNER & DANCE

FOR ALL RESERVATIONS, DETAILS AND FURTHER DISCOUNTS
 CONTACT: ELVIRA@MARINA-MAZATLAN.COM
 PHONE: 011-52-669-669-2936
 PHONE & FAX: 011-52-669-669-2937

WWW.MARINA-MAZATLAN.COM

BAJA HA-HA XVI

BROUGHT TO YOU
BY THESE
OFFICIAL SPONSORS



536 sailors completed
Baja Ha-Ha XVI!



Turn the page for more →

WWW.BAJA-HAHA.COM

The Rally Committee encourages you to patronize the advertisers who make this event possible – and take advantage of their Baja Ha-Ha Specials!

Your
Yacht Club
South of the
Border



Home
of the
Banderas Bay
Regatta

Vallarta Yacht Club

<http://vallartayachtclub.org>
<http://banderasbayregatta.com>

Everything you need from a full service yacht club.

A RECORD- BREAKING RALLY

As you may have read in Sightings, more boats are entered in this year's rally than ever before.

Along with the increased numbers, the event will have some exciting new features. For the first time ever, fleet members will parade past the western tip of Shelter Island at 10 a.m. October 26, on their way out to the 11 a.m. start. A fireboat will salute them with a shower of spray, and a variety of TV and print reporters will be on hand to capture the excitement.

If you're new to the event, let us explain that the Ha-Ha is a 750-mile cruisers' rally from San Diego to Cabo San Lucas, with stops along the way at Turtle Bay and Bahia Santa Maria.

You'll find frequent updates on this year's event, in addition to all sorts of other hot sailing topics at *Latitude's* three-times-weekly news portal, 'Lectronic Latitude' (found at www.latitude38.com.)

Summer
is safe at
Paradise



Enjoy
your stay
with us!

Paradise Village
BEACH RESORT & SPA

011-52-322-22-66728 • www.paradisevillage.com
marina@paradisevillagegroup.com

Nautical Books, Software, Charts
and more!



WAYPOINT

621 - 4th St., Oakland, CA

www.waypoints.com • (510) 769-1547

RIGGING ONLY

Standing and running rigging, lifelines, furlers, winches, headsail poles, main slider systems, windlasses, travelers, wire terminals, blocks and more...
Expert advice for selection and installation.

Our
25th Year!
www.riggingonly.com
(508) 992-0434 • sail@riggingonly.com

ICOM[®]

Icom America Inc.

Award-winning Marine Communications Equipment

Handhelds • Mounted VHF • SSB • Radar

Visit one of our many West Coast dealers

www.icomamerica.com/marine



SCANMAR
INTERNATIONAL
Factory Direct

432 South 1st Street • Pt. Richmond, CA 94804
Toll Free: (888) 946-3826 • Tel: (510) 215-2010
email: scanmar@selfsteer.com • www.selfsteer.com

West Marine
We make boating more fun![™]

Call 1•800•BOATING

(1•800•262-8464)

for a catalog or the store nearest you.

Almar
Marinas
The West's Finest

Full service
marinas –
San Francisco
to San Diego

www.almar.com

BAJA HA-HA XVI

BROUGHT TO YOU BY THESE OFFICIAL SPONSORS



WWW.BAJA-HAHA.COM

MARINA
nuevo vallarta

NOW UNDER CONSTRUCTION

Contact Dockmaster: Juan Sebastian Estrada
Ph/Fax from US: 011 52 322 297 7000
juan@marinanuevovallarta.com
www.marinanuevovallarta.com

Spinnaker & Genoa Sleeves
Top/Mast Climber

GALE SAIL • TACKER

www.atninc.com
(800) 874-3671

Sailing should be easy and safe

Let Marina El Cid
Welcome You to Mexico

A Cruiser's Paradise!

www.elcid.com
qcevallos@elcid.com.mx
011-52 (669) 916-3468

¿ MEXICO BOUND ?

SEAS OF CORTEZ CHARTS

Accurate Navigation Charts & Guides
ELECTRONIC and PAPER
www.GerryCruise.com

Early Bird Rates

MARINA RIVIERA NAYARIT
AT LA CRUZ

We Are Now Open!

The best marina – 25 minutes away from Puerto Vallarta
Tel: 322 779 91 91 or 329 29 555 26
info@marinarivieranayarit.com
www.marinarivieranayarit.com

HITCHING A RIDE SOUTH

This year's Mexico-Only Crew List Party and Baja Ha-Ha Reunion on September 9 served its purpose by linking dozens of potential crew members with skippers in need of additional watch-standers.

If you missed that shindig and would really like to spend some quality time south of the border, you might still be able to find a ride via our online Crew List at www.latitude38.com, which is constantly updated.

IS THE PACIFIC PUDDLE JUMP IN YOUR FUTURE?

For many cruisers, the next logical step after cruising Mexican waters for a season or more is to hang a right and head west into the Pacific.

We call that annual springtime migration the Pacific Puddle Jump, and report on it heavily in the pages of *Latitude 38*. Making that 3,000-mile passage is one of the most thrilling accomplishments in the realm of sailing. Learn more about the spring 2010 crossing at www.pacificpuddlejump.com.

Ventura Harbor Boatyard, Inc.

Located halfway between San Francisco & San Diego

Haulouts to 165 tons ~ Full line of marine services
Dockside services ~ On-site chandlery

1415 Spinnaker Drive, Ventura, CA
(805) 654-1433 • www.vhby.com

Not just a marina – a cruiser's community
Your best destination across the Sea...
www.marina-mazatlan.com
011-52 (669) 669-2936 & 2937
elizarraga@marinamazatlan.com

Survive Your Dream

ECHO Tec Watermakers

604-925-2660 www.hydrovane.com

A Full Service Boat Yard in Puerto Vallarta
88 ton Travelift • Parts • Service • Repairs

011-52 (322) 221-1800 www.opequimar.com
info@opequimar.com

Sausalito Marine Electrical Shop
"The Project Place"

Are your electrical, electronic, communication and safety systems ready for Baja and beyond?

CONSULT WITH A MASTER ELECTRICIAN
Design - Sale - Service

300 Harbor Drive, Sausalito, CA (415) 332-9030
www.sausalitomarine.com



NEW!
PRE-START
BOAT PARADE
10:00 AM OCTOBER 26
SHELTER ISLAND
SAN DIEGO

ULTRA ANCHORS - The quickest setting, highest holding power anchors available for you, your family and your vessel's safety.

Marine Products from the World to the USA



QuicklineUSA

15561 Computer Ln, #A, Huntington Beach, CA 92649
 714-843-6964 714-843-6906 fax

www.quickline.us or info@quickline.us

FilterBOSS
COMMANDER

"Don't Leave Shore Without It."

A complete fuel maintenance system



www.KTISYSTEMS.com

(800) 336-0315

MARINA DE LA PAZ
FULL SERVICE MARINA

Conveniently located downtown

Tel: 011-52 (612) 122-1646

Fax: 011-52 (612) 125-5900

email: marinalapaz@prodigy.net.mx

www.marinadelapaz.com

KATADYN
 MAKING WATER DRINKING WATER

Watermakers that improve the cruising lifestyle.

(800) 755-6701 • www.katadyn.com

email: marine@katadyn.com

OD36887

Cruise with Confidence

See Our Half-Page Ad In This Issue

(800) 992-4443

www.marinersinsurance.com

MARINERS
 GENERAL INSURANCE GROUP

Newport Beach, CA • San Diego, CA
 Burlingame, CA • Seattle, WA
 Bradenton, FL • Puerto Vallarta, MX

IMPORTANT DATES

Oct 18 — Ha-Ha Welcome to San Diego Party, Downwind Marine, 12-4 pm. Ha-Ha entrants only.

Oct 24 — Informational Meeting about the Pacific Puddle Jump, West Marine, San Diego, 5 pm.

Oct 25, 9 am — Final deadline for all crew and skipper waivers, West Marine, S.D.

Oct 25, 11 am — Skipper's meeting, West Marine, S.D. Skippers only please.

Oct 25, 1 pm — Ha-Ha Halloween Costume Party and Barbecue, West Marine, S.D.

Oct 26, 10 am — Pre-Start boat parade past Shelter Island

Oct 26, 11 am — Start of Leg 1

Oct 31, 8 am — Start of Leg 2

Nov 4, 7 am — Start of Leg 3

Nov 6 — Cabo Beach Party

Nov 7 — Awards presentations hosted by the Cabo Marina

Baja Ha-Ha Inc.

c/o 15 Locust Ave.
 Mill Valley, CA 94941

WWW.BAJA-HAHA.COM

PLEASE NOTE: There is no phone number for the Baja Ha-Ha Rally Committee.

Please don't call *Latitude 38* with questions. The Ha-Ha is a separate operation.



www.downwindmarine.com

2804 Cañon St., San Diego

(619) 224-2733 • (800) 269-0241



www.sandiegomarine.com

2636 Shelter Island Dr., San Diego

(619) 223-7159 • (800) 336-7369

Mexico 001-500-336-7369



www.sailingsupply.com

2822 Cañon Street, San Diego

(619) 225-9411 • (800) 532-3831



Sea of Cortez:
A Cruiser's Guidebook

The most up-to-date, accurate cruising guide detailing the remote and pristine anchorages of the Baja Peninsula and Sea of Cortez.

www.exploringcortez.com

Blue Latitude Press

Yachtfinders/Windseakers
 in the heart of
 San Diego's boating community

Specialists in cruising sailboat brokerage for 27 years
info@yachtfinders.biz • www.yachtfinders.biz

(619) 224-2349 • (866) 341-6189 toll-free

Fax (619) 224-4692

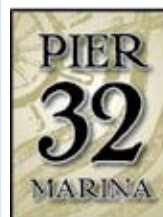

Enjoy a free night on us
 and a pre-Ha-Ha party too!

Cruiser friendly with a
 helpful staff.

(800) 729-7547

(619) 477-3232

office@pier32marina.com



A Sailor's
 Consignment
 Chandlery

(510) 769-4858

Located at Grand Marina

www.bluepelicanmarine.com

MAX EBB

"Finally!" our skipper cheered before the echoes of the gun had faded. "Postponement over! Let's get this race going!"

We'd been waiting two hours for the wind to stabilize. It had never been flat calm, but it was not the steady sea breeze the Race Committee wanted. Evidently they thought it was worth the wait.

All hands on our boat felt otherwise. They were from Southern California, in town for a major regatta, and I'd been recruited as a source of local knowledge. Fortunately, I was able to bring Lee Helm along with me. She's a naval architecture grad student at the university, and although I have a few more decades' experience racing on the Bay than she does, Lee seems to be able to make more sense out of the instruments, the polars and her custom tide charts. As long as she can pass me secret tips during the race, I can fake it pretty well.

"Wait a sec," said Lee, examining the RC boat through binoculars. "They've got the gun up for another shot."

The end of a postponement is signaled by one gun, and a postponement is signaled by two. When the second gun fired, we couldn't understand why they would postpone a race that was already postponed. Then there was a third gun.

"Code flags N over A," Lee sighed. "All races abandoned for the day."

"Darn," muttered the skipper. "I thought we'd finally have a chance to see what we could do against this fleet in light air."

"Clearly a decision driven by bar revenue," said the owner, who doesn't drive or even trim sails during the races, but loves to organize the campaign and write the checks. "The bar makes more money for the club if they get us back to the harbor early."

"Either that or someone on the RC boat has opera tickets," grouched another crew. "You'd think, what with having a whole navy out here to set marks and signal courses, they could at least give us a short course in the wind we've had all morning instead of making us wait around for the seabreeze that we all know will fill in as soon as we're back at the dock."

"Down south we race in wind lighter than this all the time," said the owner.

"We could have spent the last two hours racing."

"Yeah, since when is an RC so afraid of a wind shift that they have to cancel a whole day of sailing?" asked another crew. "I started racing on Long Island Sound, and back there we'd call this a good stiff sailing breeze."

"Before you all go off half-cocked on this," said the mainsail trimmer, trying to calm us down, "consider that one of the purposes of the regatta is to come up with an overall winner. And because they have the different divisions sailing different courses and starting at different times, their method of selecting the overall winner only works if the wind is steady."

"Well, we're sure not in it for the overall win," the owner reminded us as he stepped from the back of the cockpit to the top of the companionway ladder. "We just want to race. We came all the way up from SoCal, and they've wasted a perfectly good day of sailing. I'm going below to break out lunch. Who had the one with no mayo?"

"No tomatoes on mine," said Lee.

"They're all no tomatoes," the owner called back from the cabin. "Keeps the bread from getting soggy."

"But how can they possibly have an overall winner if the divisions are sailing different courses?" I asked.

"It's, like, in the sailing instructions, under scoring," said Lee. "What they do is take the corrected time of the winner of each division, divide by the course distance to get the corrected speed, and see who is sailing the fastest, averaged over all the races sailed."

"Sounds fair enough, if the conditions are steady."

"Except for one big thing they got wrong," Lee noted. "The finish is upwind of the start, and the big boats usually sail a course with more laps than the small boats. Especially for a series sailed in mostly flood tide, that makes a diff."

"How big?"

"Okay, we can totally figure it out. "If the course is W-L-W-L-W — or two-and-a-half sausages — for the big class, that's three upwind and two downwind legs." She produced a small cell phone in a plastic bag from her PFD pocket and switched it into calcula-



tor mode. "Let's say they go seven knots upwind and tack through 70 degrees. That's a VMG of 5.7 knots, subtract a knot for flood current and VMG upwind is 4.7. Downwind, let's be conservative and say 8.5 knots VMG plus the current, for 9.5 knots down the course. Average speed for the five legs is then . . . 6.62 knots. But if they sail the shorter course, just one-and-a-half times around, they get a higher ratio of windward to leeward because of the upwind finish. Then the average speed around the course is . . . 6.3 knots.

"Pretty close, if you ask me," I ventured.

"No way! That's, like, a five percent rating advantage. Ginormous compared to typical finish margins in a top-end fleet."

"What about when the course is three-and-a-half laps versus two-and-a-half?"

$$\sqrt{\frac{\sum_{i=1}^n \left(T_i - \frac{1}{n} \sum_{j=1}^n T_j \right)^2}{n-1}}$$

The formula for Sample Standard Deviation. *T* is corrected time and *n* is the number of finishers in the division.

— A NUMBERS GAME

Things may have turned out differently for 'Soozal' at last month's Rolex Big Boat Series if organizers had used Lee Helm's calculations.



PETER LYONS / WWW.LYONSIMAGING.COM

consistent seconds and thirds," said the trimmer. "I think a comparative low-point system would be better."

"Except that some divisions are larger than others," said the skipper, "and a low-point finish is much more difficult to earn in a big division. You could do a kind of proportional low-point. Or add up corrected time margins."

"That still leaves the problem of some classes being more competitive than others," said Lee. "But, like, there is a way to take that into account."

"I can't think how," I said.

"There are tons of different statistical criteria to measure how tight the results are. I mean, if we assume that a competitive fleet will have more tightly bunched finishes, then all you have to do is take the standard deviation of the corrected time finishes, and see how big the winning margin is over the average time, in terms of standard deviations. The division winner who beats their class average by the greatest number of standard deviations is the overall winner. That automatically corrects for the variations in the size of the divisions and for how tight the racing is in each division."

"You lost me when you got to deviation," said the foredeck crew, scooping up a handful of cookies. "Are we talking compass

asked the trimmer. "The effect should be a lot less."

Lee ran her calculations again, and determined that the error was down to about two percent for the courses with more legs.

"How much is two percent in PHRF?" asked the foredeck crew.

"About 12 seconds per mile for you time-on-distance folks," Lee said, "More when the wind is up and the speed difference between upwind and downwind is bigger."

"A two percent skew in favor of the big class," said the trimmer, "doesn't seem like that big of an error compared to the difference in wind and tide if conditions aren't steady. The small class start is, what, 50 minutes after the big boats?"

"I guess they have to have an overall winner, and I guess they're going to do it their way," said the skipper as he pushed

the button to start the engine. "Mainsail down any time," he ordered, and most of the crew jumped into position to flake the main while Lee and I took charge of the bags of sandwiches and snacks that the owner was passing up the hatch.

"**M**ax, how would you determine the overall winner for an event like this?" asked the mainsail trimmer once the sail was down and flaked.

"It's a tough problem," I allowed, "but there are ways that don't constrain the options of the RC like the method they used. I'd probably just do something simple like give it to the boat with the greatest number of firsts in its division. That way each division could be in completely different conditions and everything would be fine."

"But then a boat with, for example, one lucky first place and five finishes in the tank would beat out a boat with

cards all of a sudden?"

"It's just the square root of the sum of the squares of the differences from the mean divided by the number of points minus one," Lee explained through a mouthful of tuna sandwich. "My calculator even has a button for it."

"Just so we know what you're talking about, can you explain how you would calculate it without the button?" asked the skipper.

"Okay, first take all the corrected finish times, Add them up and divide by the number of boats to get the average corrected finish time."

"We got that part."

"For each boat, subtract to find the difference between that boat's finish time and the average finish time, and square that number."

"I'm already confused," said the foredeck crew. "Some of those time differences will be positive and some will be negative, depending on which you subtract

MAX EBB

from which, and whether the boat was ahead or behind the average."

"No, that doesn't matter," explained Lee, "because all the time differences are squared and come out positive anyway."

"Got it."

"Now add up all those squares of time differences, divide by the number of boats minus one, and take the square root of that. The answer is called the standard deviation, and for a normal distribution of values, about 95% of the values fall within plus-or-minus two standard deviations of the average."

"Ah, but in this case you have a complete sample set," the owner called up

Overall winner by the Lee Helm criterion

corrected finish times	Class A				Class B				Class C				Class D			
	H	M	S	minutes	H	M	S	minutes	H	M	S	minutes	H	M	S	minutes
2 29 56	149.93	2 31 15	151.25	1 48 23	108.38	1 52 56	112.93									
2 30 26	150.43	2 35 6	155.10	1 49 26	109.43	1 54 27	114.45									
2 30 39	150.65	2 39 38	159.63	1 52 20	112.33	1 57 3	117.05									
2 32 16	152.27	2 39 59	159.98	1 52 24	112.40	1 58 59	118.98									
2 34 29	154.48	2 41 42	161.70	1 52 45	112.75	2 0 26	120.43									
		2 42 49	162.82	1 54 13	114.22	2 0 39	120.65									
		2 50 40	170.67	1 59 36	119.60											
		2 52 39	172.65	2 2 7	122.12											
		2 53 18	173.30													

	Class A	Class B	Class C	Class D
average corrected time	151.55	163.01	113.90	117.42
winning margin over average	1.62	11.76	5.52	4.48
standard deviation	1.86	7.75	4.73	3.20
winning margin / standard deviation	0.87	1.52	1.17	1.40

Lee's Criterion for calculating an overall winner, using the first race of last month's Rolex Big Boat Series as an example. The tightest competition was in Division A, but the Division B winner takes it with a much larger margin over the average, despite the more dispersed finishes. In Divisions C and D, sailing a shorter course, the D winner gets more credit for a win in the tighter fleet, putting them ahead of the C boat, despite a slower corrected time.

from the cabin. "So there's no need for Bessel's correction. You should divide by N, not N-1."

"For sure, we have all the finish data," argued Lee, "but it's a statistical sampling of speed potential. So I think the

sample standard deviation, using N-1, is more accurate than the uncorrected value."

Lee and the owner debated this point for some time, each volley less comprehensible than the last, but neither could convince the other. Eventually they gave up and finished their sandwiches.

That evening at the awards banquet, we saw the results of the overall winner selection method. Sure enough, a boat in the big class had taken it.

"After all, they did spend the most money," noted the owner.

— max ebb



RICHARDSON BAY MARINA

formerly Kappas Marina

MODERN FACILITIES IN A WELL-PROTECTED HARBOR

Concrete Dock System

Well Maintained Facilities

Beautiful Surroundings

- DEEP WATER BERTHS: BASIN AND CHANNEL DREDGED
- CARD KEY SECURITY SYSTEM
- DOCK CARTS
- PUMP OUT STATION
- AMPLE PARKING
- CLEAN SHOWER AND TOILET FACILITIES
- WITHIN WALKING DISTANCE: MARKET/DELI, LAUNDROMAT, RESTAURANT
- AT EACH BERTH: LARGE STORAGE BOX, METERED ELECTRICITY, PHONE HOOKUPS, WATER

BERTH YOUR BOAT IN SAUSALITO

415 332-5510 www.richardsonbaymarina.com
100 Gate Six Road, Sausalito • Fax 415 332-5812

IN A PUFF, MATRIX IS NO GIVE AND ALL GO



UK-Halsey's Matrix sails are the highest performance loadpath sails we make. When light weight and low stretch are critical, you need to put Matrix in your corner. Call UK-Halsey at 510-523-3966



www.ukhalsey.com

New Member
Showers and
Laundry Facilities
Now Open!

Emeryville Marina

ON THE BAY

NEW SLIPS!

Available Fall/Winter 2009
Now taking reservations
for 40' to 60'

When you call Emeryville Marina Home...
...call this your backyard!

Free Wi-Fi
and Video
Surveillance

Slips from 20-65 ft
Full Amenities - including
Fuel Dock & Pumpout Station

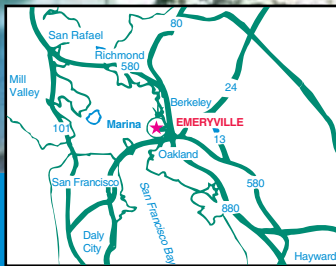

MARINAS[™]
International

(510) 654-3716
www.emeryvillemarina.com



**FREE GEAR FROM
SVENDSEN'S!**



When you buy a Laser Performance boat from Svendsen's Marine before 12/31/09, you get a free Seitech Dolly **OR** Hull & Deck Covers, **PLUS** Your Choice of Either...

A Ronstan Regatta Watch...

OR

...a Gill Dry Bag & Sunglasses!



SALE ENDS 12/31/09-BUY NOW!



**SVENDSEN'S
MARINE** 510.521.8454
1851 Clement Avenue in the Alameda Marina

CDI
Cruising Design, Inc.

The best value and reliability

- Mainsail and Jib reefing
- The only U.S. patented furling system for Cruising Spinnakers
- Manage all your sails safely from the cockpit!

607.749.4599

www.sailcdi.com

sailcdi@verizon.net

THE RACING

Whew! The end of August and the month of September were jam packed with racing on the Bay. Between the **Folkboat Internationals**, the **Windjammers' Race**, **SAP 505 World Championships**, and **Jazz Cup** there was plenty to keep any kind of sailor busy. But we better not forget the **Melges 32 North Americans**, the **29er US Nationals**, a record-matching **Leukemia Cup**, the **J/24 Western Regionals**, **St. Francis 18-ft Skiff Regatta**, **Ronstan Bridge to Bridge** race, **Catalina 30 Nationals** and, oh yeah, *The Great Schooner Race* and the *Rolex Big Boat Series*, which you'll find on pages 108-110, and 88-96 respectively. Yeah, it was busy. As always, we've done our best to bring you the scoop on all these events. Enjoy!

Folkboat Internationals

The Folkboat Internationals are held biennially on the Bay, and the boat's strong and loyal following, plus the fact that more than 5,000 have been built, means that the racing is competitive.

With a bullet in the final race, '07 winner Dave Wilson from San Francisco, held off a consistent performance from another Bay Area sailor, Eric Kaiser — who had counted nothing lower than a third in the seven-race, one-throuout series — to take the title.

Sailing with his father Don, and for the first two days, Mark Van Crienkge, who was spelled by Tom Urbania for the final two, Wilson's final bullet was one of three that propelled him to a two-point win at the Corinthian YC-hosted regatta September 15-19. Following the Bay Area sailors were a pair of Danes — Per Jørgensen and Per Buch — and a German Christoph Nielsen.

Nielsen was the only foreign skipper who didn't take advantage of the local

The fleet hit many of the Central Bay venues for the racing — sailing on the Circle one day, the Cityfront another and Knox on two different days.

"In the seven races, we had five different winners," said Class President Brock de Lappe.

The boat — *Windansea* — has been in the Wilson family since 1981, when it was brought over for exactly such an event. Don Wilson is a three-time season champion.

But the Wilson father/son winning combo wasn't the only one on the course. Tom Reed, Sr., a seven-time season champion, was sailing for his son, Tom Reed, Jr.

Kaiser's father, Chuck, is also a seven-time season champion. When you see all these fraternal connections that come with some serious credentials, it's easy to see why Wilson was a bit surprised by his win.

"We didn't think it was really going to happen," Wilson said. "We weren't really anticipating that we'd

be winning. We went over to Sweden for the Gold Cup last year, and the Germans won, while we were 19th. Eric's been really consistent this whole year, so we feel lucky to have pulled it out."

"When it comes to consistency," Kaiser said, "I look to what my dad used to say: 'Racing sailboats is a series of routines practiced and mastered.' I certainly haven't mastered them yet, but I continue to strive towards that goal. Ironically, it was some-

thing Dave Wilson said that has really stuck in my head, and that's being obsessive about balancing the helm, both up and downwind. That has taken my sailing to a higher level this past year. But if you look closely, Dave has the upper hand when it comes to consistency."



Dave Wilson, left, just barely edged out Eric Kaiser for the top spot at the '09 Folkboat Internationals September 14-19.

fleet's pooling of loaner boats; he shipped his own Folkboat — they just fit inside a standard 40-ft shipping container — over for the event. Nielsen was in position to notch the Folkboat equivalent of a Grand Slam, having already won the Swedish National Championship, Kiel Week and the class' Gold Cup.



PETER LYONS/WWW.LYONSIMAGING.COM

Like Wilson, Kaiser — who actively sails his boat *Josephine* on the Bay — built his crew around two guys sailing for two days each, and one pivotal player.

"The team I put together started with the one guy I knew would never stop trying, Sean Svendsen," Kaiser said. That guy is intense and I loved it. Mike Peterson, also a Knarr season champion, understood how to keep both Sean and I under control. I guess we both have a tendency to get a little heated in the moment. He really did an outstanding job the first two days of the regatta. The last two I had my regular crew, Kurt Hemmingsen."

FOLKBOAT INTERNATIONALS (9/15-19: 7r/1t)

— 1) #106, **David Wilson**, USA, 12; 2) #122, **Eric Kaiser**, USA, 14; 3) #871, **Per Jørgensen**, DEN, 24; 4) #926, **Per Buch**, DEN, 27; 5) #658, **Christoph Nielsen**, GER, 32. (19 boats)

Complete results at www.cyc.org

Windjammers

Labor Day Weekend featured the Windjammers Race from the Bay down the coast to Santa Cruz. Conditions



Corinthian YC hosted Folkboat sailors from around Northern Europe and San Francisco Bay. The one day spent sailing on the Circle, shown above, produced five successfully recovered MOBs.

were plenty breezy — boats were seeing upwards of 35 knots below Año Nuevo. But the big north-northwesterly shut off late in the afternoon, giving way to an easterly that trapped much of the 37-boat fleet in little breeze.

Bill Turpin's R/P 78 *Akela* tore down the coast in only 6h, 10m, 35s, but was pipped at the post for overall honors by Shepard Kett's SC 50 *Octavia* by a mere 6.5 minutes. Kevin Flanigan and Greg Nelsen's Fox 44 *Ocelot* corrected out to third overall, a little less than 12.5 minutes behind *Akela*.

WINDJAMMERS (9/4)

PHRO1A — 1) *Octavia*, SC 50, Shepard Kett; 2) *Akela*, R/P 78, Bill Turpin; 3) *Ocelot*, Custom Fox 44, Kevin Flanigan. (13 boats)

PHRO1 — 1) *Heartbeat*, Wylie 46, Lou

Piambanco; 2) *Timber Wolf*, Farr 38, David Hodges; 3) *Made Easy*, Beneteau 42, Jim Peterson. (10 boats)

PHRO2 — 1) *Evening Star*, Cal 40, Walter Smith; 2) *No Ka Oi*, Gibsea 42, Phil Mummah; 3) *Galaxsea*, Nauticat 43, Daniel Willey. (5 boats)

MORA — 1) *Always Friday*, Antrim 27, John

Shepard Kett's 'Octavia' heads out the Gate on the way to an overall win in the Windjammers.



PETER LYONS/WWW.LYONSIMAGING.COM

Liebenberg; 2) *Saffron*, SC 27, Charlie Abraham; 3) *Patience*, SC 27, Christopher Luhn. (4 boats)

CLASS B (MOTOR ALLOWED) — 1) *Absolute 5*, Santana 35, Keith MacBeth; 2) *Pegasus*, J/35, Marc Sykes. (4 boats/2 ret.)

OVERALL — 1) *Octavia*; 2) *Akela*; 3) *Ocelot*; 4) *Roller Coaster*, SC 50, Jack Gordon; 5) *Heartbeat*; 6) *Delicate Balance*, Andrews 56, Team DB; 7) *Morpheus*, Schumacher 50, Jim Gregory; 8) *Ragtime*, Spencer 65, Chris Welsh; 9) *Twisted*, Farr 40, Tony Pohl/Mike DeVries; 10) *Timber Wolf*. (37 boats)

Complete results at: www.windjammersrace.org

SAP 505 Worlds

With fluid boathandling and blinding all-around boatspeed, Newport Beach's Mike Martin and Jeff Nelson won the 2009 SAP 505 World Championship with a dominant performance on the Berkeley Circle August 23-29.

Hosted by the St. Francis YC, the regatta came to the Bay for the first time since 1981.

A 46-second victory in the final race meant that, over the nine-race, two-throwout series, the Martin and Nelson counted only one finish that wasn't a bullet against the 97 other boats in the fleet — a second. Cashing in their throwouts on a mast broken in the Circle mud, and a tough race in the fluky, light air conditions that descended over the Bay during the middle of the regatta, the duo shrugged off the bad breaks and came up big in the clutch to hold off Santa Cruz' hard-charging Mike Holt and Carl Smit.

From the word "go" it was really a two-boat regatta between Martin/Nelson and Holt/Smit, and both teams quickly distanced themselves from the pack, which included Aussie Chris Nicholson — an Olympian, JJ Giltinan winner and

THE RACING

RICH ROBERTS



ERIK SIMONSON/WWW.MARINEMEDIAALLIANCE.COM



RICH ROBERTS



SERGEI ZAVARIN/WWW.ULTIMATE-YACHTSHOTS.SMUGMUG.COM

LATITUDE/ROB



RICH ROBERTS

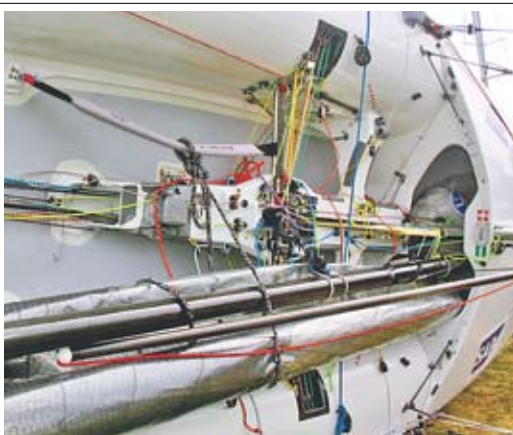

ERIK SIMONSON/WWW.MARINEMEDIAALLIANCE.COM



A taste of the '09 SAP 505 Worlds: clockwise from top left — reaching legs and bright kites, favorites of sailing photographers everywhere, are still an essential part of the 505 class; a perfect illustration of why the 505 crew is said to "drive the boat"; in gate start, everyone ducks the "pathfinder" instead of using a normal line, the result is that there's rarely a general recall; this was a common scene throughout the week; Jeff Nelson, left, and Mike Martin; you can see why the 505 is a favorite class of cordage manufacturers; Martin and Nelson bomb downwind; these guys weren't special, and estimated 45 rigs came down during the course of the week; Michael and Mark Lazzaro's boat, the oldest in the fleet, was later recovered.

Volvo Ocean Race veteran — and American Olympians Nick Adamson and Steve Bourdow.

"There was a bit of nervousness at the start," Martin said afterward. "But in the end . . ."

In the end, after the breeze had built from 12 knots to past 20 in the 3 1/2-lap,

hour-and-a-half-long race, Martin and Nelson were in their element, seemingly invincible, as they notched their sixth bullet — with a 10-year-old spare rig.

Michael and Mark Lazzaro's difficult week — they finished only three races, which was more than three other teams and equal to quite a few others — ended

when their number 5281, the oldest boat in the fleet, sank in 10 feet of water near the leeward gate. They were rescued from the 62-degree water and the boat was later recovered.

Back at the Crissy Field boat yard after the six-mile upwind sail from the race course, Martin and Nelson were



ERIK SIMONSON/WWW.MARINEMEDIAALLIANCE.COM



RICH ROBERTS



greeted with enthusiastic laughs, smiles and hugs by their sailing buddy, Howie Hamlin of Long Beach, and Paul Cayard, Hamlin's substitute crew for the week, who wound up seventh overall.

Martin was Hamlin's crew when they won the 505 Worlds 10 years ago, and Hamlin noted, "Nobody has ever won the 505 Worlds as a crew and then as a skipper. It's well-deserved. He's worked for it a long time. He loves breeze. He always has."

Cayard said that, at 50, "it was a lot

of fun" handling spinnakers and hanging out on a trapeze in his boyhood waters, returning to his roots from a long career of sailing America's Cups, Whitbread/Volvo round-the-world races and other big boat ventures.

"I woke up this morning and realized I wouldn't be waking up again to go sailing in a 505," Cayard said, wistfully. "Small boat sailing is what I gave up doing to do what I do 99% of the time now."

Holt/Smit dogged Martin/Nelson into the Gate "rabbit" starting sequence that

developed into an odd sort of match race. Butl Martin broke free while running the line on port tack against the starboard tack fleet waiting to cross behind the Gate boat following the rabbit, who was Findel/Tellen.

"We were able to get away just enough to tack to starboard," Martin said. "When we tacked, we were perfectly lined up with a good clear lane, and we were off."

"We knew it was going to be tough today," Smit said. "We needed them

THE RACING

to make a mistake. They didn't make any."

"We gave it a shot but he was faster," Holt added. "We tried to go for him at the start . . . did everything in our power."

With everything from a VIP mini-me-gayacht for paying spectators, as many as two helicopters flying overhead, and sponsorship from software company SAP — whose founder, Hasso Plattner, has probably spent more time sailing his 505 than his MaxZ86 *Morning Glory* in the last couple years — the atmosphere at the '09 SAP 505 Worlds was anything but that of your typical dinghy regatta.

With an estimated 45 rigs broken in the three days of truly testing conditions on the Circle, plus more than a handful of rudders — particularly those with tapered blades — that broke due to the forces they were subjected to, it wasn't even a typical 505 Worlds. Not only were the conditions trying — at times the breeze easily scratched 30-plus knots — but after sailing a pair of races for a total of nearly four hours, the fleet had to sail what was effectively a triple-weather leg just to get back to the launching area at Crissy Field.

2009 SAP 505 WORLDS (8/23-29)

PHRO1A — 1) **Mike Martin/Jeff Nelson**, USA 8 points; 2) **Mike Holt/Carl Smit**, USA, 16; 3) **Chris Nicholson/Casey Smith**, AUS, 26; 4) **Jens Findel/Johannes Tellen**, GER, 36; 5) **Dalton Bergen/Fritz Lanzinger**, USA 38; 6) **Nick Adamson/Steve Bourdow**, USA, 38; 7) **Howie Hamlin/Ian Mitchell/Paul Cayard**, USA, 44; 8) **Tyler Moore/Geoff Ewenson**, USA, 63; 9) **Ryan Cox/Stuart Park**, USA, 63; 10) **Ian Pinnell/Carl Gibbon**, GBR, 66. (98 boats)

The South Beach and Benicia YC's 100-plus boat Jazz Cup was pleasant and reachy.

Complete results at: www.stfyc.org

Jazz Cup

The South Beach and Benicia YC's Jazz Cup drew over 100 boats for the downwinder between the two clubs September 5. Using the 20-knot breeze and 1.5-knot flood to its advantage, Roger Barnett's ProSail 40 *Tuki* took the overall honors in the 27-miler — finishing in just over two hours and correcting out over Ross Stein's F-24 *Origami* by almost 5.5 minutes.

The first monohull on corrected time was Tim Russell's Wylie Wabbit *Weckless*, which corrected to third overall. Six erstwhile finishers were DSQ'd for not rounding a new mark near the finish, "Bales."

The Jazz Cup itself, which can only be won by a member of either host club went to Simon James' Ranger 26 *Star Ranger*.

JAZZ CUP (9/05)

NON-SPIN — 1) **Krissy**, Ericson 35-3, Allen Cooper; 2) **Flight Risk**, Catalina 38, Daniel Gaudy; 3) **Crazy Diamond**, Liga & Soren Hoy. (7 boats)



CATALINA 30 — 1) **Goose**, M&L Kastrop; 2) **Starkite**, Laurie Miller; 3) **Huge**, Bill Woodruff. (5 boats)

PHRF ≥ 160 — 1) **Star Ranger**, Ranger 26, Simon James/Tim n/a; 2) **Synergizer**, Ericson 28, Larry Weinhoff; 3) **Don Wan**, Santana 28, Don Kunstler. (7 boats)

PHRF 130-159 — 1) **Arcadia**, Modernized Santana 27, Gordie Nash; 2) **Crews Nest**, Catalina 34, Ray Irvine; 3) **Sea Spirit**, Catalina 34, Laurence Baskin. (13 boats)

SF BAY 30 — 1) **Takeoff**, Laser 28, Joan Byrne; 2) **Gammon**, Tartan 10, Jeffery Hutter, 11; 3) **Lazy Lightning**, Tartan 10, Tim McDonald. (5 boats)

PHRF 100-129 — 1) **Weckless**, Wylie Wabbit, Tim Russel; 2) **Mon Desir**, Jeanneau SF, Jerry Nasso; 3) **Bluefin**, Santana 35, Noble Griswold. (13 boats)

EXPRESS 27 — 1) **Desperado**, Mike Bruzzone; 2) **Wile E Coyote**, Dan Pruzan; 3) **Tule Fog**, Steve Carroll. (5 boats)

SPORTBOATS (PHRF ≥ 90) — 1) **Flight Risk**, T650, Ben Landon; 2) **Hoot**, Olson 30, Andrew Macfie; 3) **Boracic**, Open 5.70, Michael Gough. (3 boats)

SPORTBOATS (PHRF ≤ 89) — 1) **Jet Stream**, JS 9000, Dan Alvarez; 2) **Word**, Mumm 30, Bill Erkelens; 3) **Kika**, Flying





The Sausalito YC-hosted Melges 32 North Americans turned out a small fleet of seven boats with competition as tight as you see here. Don Jesberg, inset, and his all-Corinthian crew — the only one at the regatta — came out on top after a hard-fought series.

Tiger, Marc Pinckney. (9 boats)

PHRF \leq 99 — 1) **Yucca**, 8 Metre, Hank Easom; 2) **Bullet**, Express 37, Michael Maloney; 3) **Savoir Faire**, Beneteau First 42, Paul Osborn. (16 boats)
CORSAIR 24 — 1) **Origami**, Ross Stein; 2) **Flash**, Brett Nelson, 8; 3) **Wings**, William Cook. (7 boats)

MULTIHULLS — 1) **Tuki**, Prosail 40, Roger Barnett; 2) **Lanikai**, Cruising, John Brady; 3) **Wahoo!**, Dolphin 460, Gary Thompson. (6 boats)

OVERALL — 1) **Tuki**; 2) **Origami**; 3) **Flash**; 4) **Weckless**; 5) **Flight Risk**; 6) **Jet Stream**; 7) **Arcadia**; 7) **Word**; 8) **Star Ranger**; 9) **Lanikai**; 10) **Hoot**. (103 boats)

Complete results: www.southbeachyc.org

Melges 32 North Americans

The 2009 Melges 32 North Americans was hosted by Sausalito YC September 6-8. Despite being the only boat without at least one pro aboard, *Viva* — sailed by Mill Valley's Don Jesberg and an



all-Corinthian crew — ended up atop the seven-boat fleet after the eight-race, one-throwout series. Jesberg was joined by Zarko Draganic, Andrew Holdsworth, Thomas Iseler, Eric Baumhoff, Steve Marsh, Jeff Wayne and Kristin Loewenthal.

While the fleet wasn't large, it was stacked with talented, big programs like Jim Swartz's USA-007 *Q*, John Kilroy Jr.'s *Samba Pa Ti* and Stephen Pugh's *Taboo*. What the Rolex Big Boat Series — which

functioned as the class' national championship — didn't get for weather later in the week, the North Americans got in spades with breeze in the 20s, and sunshine.

29er US Nationals

Northern California sailors Max Fraser and David Liebenberg gave the 25-boat fleet that gathered at St. Francis YC September 18-20 for the 29er US Nationals a severe spanking. The duo finished the regatta with a 20-point cushion over runners-up Sterling and Hans Henken

— the top youth team — in the eight-race, one-throwout series. After dropping a sixth, Fraser and Liebenberg counted all bullets and a fourth, and were one of only six boats in the 25-team field to not take at least one letter score.

The source of all those letter scores was breeze that scratched the mid-20s with a ripping ebb that turned the Cityfront into a field of moguls. The top women's team honors went to Julia Paxton and Nina Malingri who finished fifth, just three points behind third place JP Barnes and the American 49er crew from Qingdao, Chris Rast — themselves only a point ahead of Northern Californians Finn and Alek Nilsen.

Leukemia Cup

The 2009 Leukemia Cup hosted by the San Francisco YC produced a lot more than winners in the 10 one-design and six handicap divisions. We're happy to report that, as we went to press, the regatta's fundraising figures were up to \$650,000 in only its fourth year — matching last year's record haul thanks in part to an anonymous \$250,000 donation.

There was a keynote address the night of September 19 by the country's former V.P. Al Gore, that we heard was very upbeat. Over 100 boats showed for the big boat classes, with the one-design racing run on Saturday by St. Francis YC and the handicap racing by San Francisco YC on Sunday. Seventy-two Optimists also came out for two days, hosted by SFYC,



Max Fraser and David Liebenberg took the 25-boat fleet at the 29er US Nationals to school — scoring all bullets and a sixth to take the title by 20 points.

which also counted as the class's Pacific Coast Championships.

Because the regatta happened late in our editorial cycle, we were unable to do

LESLIE RICHTER/WWW.ROCKSKIPPER.COM

ERIK SIMONSON/WWW.H2OSHOTS.COM

THE RACING

a comprehensive report in this month's issue. Look in the November issue for more on this fantastic event, the people who make it happen and the people who support it. For results please see www.sfyj.org.

J/24 Western Regionals

The 2009 J/24 Western Regional Championship — a feeder event for the J/24 Nationals the following weekend — was hosted by the exceptionally hospitable Berkeley YC on September 19-20. A practice race on Friday evening allowed visiting teams to orient themselves to local conditions before the racing kicked off.

Seventeen teams from across the country raced seven relatively short courses on the Circle under the support of PRO Jeff Zarwell. Conditions on Saturday started off light with just eight knots of breeze but filled in later to 16 knts. Sunday saw a similar start — just five knots for the first race — but ended with a romping 22 knots for the last race of the series.

Keith Wittemore's Seattle-based *Tundra Rose* took overall honors but the racing was as tight as one would expect in a fleet such as this. *Tundra Rose*, Ed Walker's Richmond-based *Small Flying Patio Furniture*, and Scott Milne's Seattle-based *Tremendous Slouch* all nailed bullets — 4, 2 and 1, respectively. By winning, Wittemore has qualified for the 2010 World Championship in Malmo,



Scenes from the J/24 Western Regionals, held on the Bay September 19-20. A tune-up event for the Nationals the following weekend, the regatta was won by Seattle's Keith Wittemore.

Sweden, next August.

J/24 WESTERN REGIONAL CHAMPIONSHIP (TYC, 9/19-20, 7r/0t)

— 1) **Tundra Rose**, Keith Wittemore, Seattle, 16; 2) **WIP**, Mark Hillman, Annapolis, 23; 3) 3

Big Dogs, Pat Toole, Santa Barbara, 26; 4) **Small Flying Patio Furniture**, Ed Walker, Richmond, 37; 5) **TMC Racing**, Michael Whitfield, Berkeley YC, 39. (17 boats)

Complete results at www.j24westernregionals.com

THE BOX SCORES

BVBC MONDAY NIGHT MADNESS (nothing posted for September)

BENICIA YC THURSDAY NIGHTS (9/10)

A FLEET — 1) **Bay Loon**, Grant Harless; 2) **Enigma**, Randall Lesley; 3) **Bluefin**, Noble Griswold. (3 boats)

B FLEET — 1) **Stolen Moments**, Deborah Lyons; 2) **Too Tuff**, Tom Hughes; 3) **Warwhoop**, Chuck Hooper. (3 boats)

C FLEET — 1) **Yippee!**, John and Johanna Wright; 2) **Alte Liebe**, Jerry Martin; 3) **Katie Bay-b**, Mike Munn. (5 boats)

CORSAIR — 1) **Gaijin**, Pete Adams; 2) **Flash**, Brett Nelson. (2 boat)

Complete results: www.beniciaachtclub.com

CORINTHIAN YC FRIDAY NIGHT SERIES (8/28)

J/105 — 1) **Donkey Jack**, Rolf Kaiser. (1 boats)

SPINNAKER 3 — 1) **Wuda Shuda**, Soverel 26 OB, Craig Page; 2) **Can O' Whoopass**, Cal 20, Richard vonEhrenkrook; 3) **Vague Unrest**, Rhodes 19, Phil Simon. (6 boats)

NON-SPINNAKER 3 — 1) **Fantasea Islander**,

Islander 28, Kevin Reilly; 2) **Road Runner**, Ranger 23, Sherri Wilkinson. (2 boats)

NON-SPINNAKER 1 — no boats
SPINNAKER 2 — 1) **Tiburón**, SC 37, Steve Stroub. (22 boats, 1 finisher)

NON-SPINNAKER 2 — no boats
Complete results: www.cyc.org

GOLDEN GATE YC FRIDAY NIGHT SERIES (8/28)

1) **Polperro**, Folkboat, Peter Jeal; 2) **Snafu**, Canadian Sail, Maurice Quillen; 3) **Rambler**, Cal 20, Mike Farrell. (7 boats)

Complete results: www.ggyc.org

IYC SUMMER TWILIGHT SERIES (8/28)

DIVISION A (PHRF 0-150) — 1) **Twisted**, Farr 40, Mike DeVries/Tony Pohl 2) **Szygyg**, Wabbit, Simone Winer; 3) **Uno**, Wyliecat 30, Steve Woner. (6 boats)

168 RATERS — 1) **Phantom**, J/24, John Guilford; 2) **Bandido**, Merit 25, George Gurrola; 3) **Bewitched**, Merit 25, Laraine Salmon. (5 boats)

DIVISION D (PHRF > 150) — 1) **Dumbo**, Catalina 22, David Torrisi; 2) **Wuvulu**, Islander 30, John

We need your help with beer can scores. We don't have the time or manpower to chase down results. You have to either post them on a website or send them directly to the race editor at rob@latitude38.com.

Our format, for these many years, is to include the name of the boat, the type and length of boat, and the first and last names of the owner(s). The following are the only results that were posted online for September. Don't forget the *Latitude 38 Beer Can Challenge*: sail every night at a different beer can race in any given week, then send us photo documentation, and we'll send you some swag to commemorate your pursuit of sailing satisfaction.



18-ft Skiff International Regatta

While it's a tradition to dunk the regatta winners in some classes, at the eighth annual 18-ft Skiff International Regatta hosted by St. Francis Yacht Club August 31 to September 8, the winners were the only ones who didn't get dunked.



Long Beach's Howie Hamlin and his crew Paul Allen and Matt Noble won it the hard way on the final day of the regatta, by coming from behind in the 10th final race to finish one point ahead of Australian John Winning. But mostly they did it by keeping their Harken-sponsored skiff right-side-up as everyone around them was doing tumbling acts in the toughest conditions of the five-day event.

When it's blowing a solid 20- to 25-knots with gusts to 28, sailing an 18-footer is a high-wire act in a hurricane, and capsizing is part of the game. But

Hamlin's team remained the only one of 13 that never flipped, certainly a factor in achieving his fifth win in this regatta.

Hamlin came into the day with a one-point lead, but Winning had two advantages: an edge in the event of a tie by virtue of having won more races, plus a one-point edge on the second discard that would take effect after the ninth race.

So Hamlin almost needed to win both races because Winning likely wouldn't be far behind in either. Hamlin's was the first boat on the course, checking currents as well as wind directions, and he

THE BOX SCORES

New; 3) **Dominatrix**, Tartan 30, Heidi Schmidt. (7 boats)

NON-SPINNAKER — 1) **N/N**, Hobie 18, Mike Berndt; 2) **Svenska**, Peterson 34, Fred Minning; 3) **Fun Zone**, Santana 22. (5 boats)

Complete results: www.lyc.org

MPYC SUNSET SERIES (9/16)

PHRF A — 1) **Calphurnia**, Duncan; 2) **Bustin' Loose**, Pulford. (2 boats)

PHRF B — 1) **Tickle**, Carder; 2) **Tekeela**, pulford; 3) **Morpheus**, Srigley. (3 boats)

SHIELDS — 1) **October**, Jackson; 2) **Harriet**, Stratton; 3) **Yankee**, Furney (3 boats)

Complete results: www.mpyc.org.

VALLEJO YC WEDNESDAY NIGHTS (7/14)

A FLEET — 1) **X-TA-C**, Olson 29, Sweitzer; 2) **Tutto Bene**, Beneteau 38S5, Vetter; 3) **Summer & Smoke**, Beneteau Frist 36.7, Orr (3 boats)

B FLEET — 1) **Somewhere In Time**, Schock 35, Ochs; 2) **Ay Chihuahua**, Ultimate 20, Gonzales/Mendez; 3) **Sea Wolfe**, Hunter 376, Spinetti. (4 boats)

Complete results: www.vyc.org

SAUSALITO YC SUNSET SERIES (9/25)

J/105 — 1) **Streaker**, Ron Anderson; 2) **Jose Cuervo**, Sam Hock; 3) **Roxanne**, Charles James. (5 boats)

DIVISION A — 1) **Gammon**, Tartan 10, Jeff Hutter; 2) **Lynx**, Wyliecat 30, Steve Overton; **J Hawk**, J/133, Dale Flaming. (8 boats)

DIVISION C — 1) **Venture**, Jeanneau 49, Michael Chobotov; 2) **Quicksilver**, C&C 39, Carl Robinette; 3) **True North**, Baltic 42, Jeff Dunnavant; 4) **French Kiss**, Beneteau 350, Dave Borton. (10 boats)

DIVISION D — 1) **Tackful**, Santana 22, Lawler/Sterhoff; 2) **Serendipity**, Cal 29, Phil Hyndman; 3) **Roebot**, Catalina 30, Rod Decker. (7 boats)

Complete results at: www.syconline.org

ST. FRANCIS YC:

CABRINHA THURSDAY NIGHT KITEBOARDING SERIES (9/17, 9/24)

OVERALL — 1) Stefaans Viljoen, 5 points; 2) Jeff Kafka, 5; 3) Geoff Headington, 5. (52 kites)

MASTER — 1) John Gomes, 15 points; 2) Eric Geleyense, 21; 3) Marcelo Segura, 24. (11 kites)

GRAND MASTER — 1) Bob Smith, 26 points;

Bret Herscher, 30. (6 kites)

FRIDAY NIGHT WINDSURFING SERIES (9/11)

SEASON STANDINGS — 1) Eric Christianson, 17 points; 2) Steve Bodner, 20; 3) Al Mirel, 25; 4) David Wells, 44; 5) Chris Radkowski, 47. (13 boards)

SVENDSEN'S THURSDAY NIGHT SERIES TISC CUMULATIVE, FINAL 2009

VANGUARD 15 — 1) **Jim Barkow/Katie Shuman**, 269 points; 2) **Andrew Watters/Maddy Eustis**, 261; 3) **Ken Turnbull/Rebecca Beard**, 259; 4) **Phillip Laby/Amy Guarnieri**, 238; 5) **Matthew Sessions/Avery Patton**, 223. (40 boats)

Complete results at: www.vanguard15.org

LASER — 1) **Marc Jux**, 166 points; 2) **Mark Halman**, 158; 3) **Mike Bishop**, 148; 4) **Ryan Nelson**, 142; 5) **Steve Orosz**, 127. (24 boats)

Complete results at: www.tilasrflleet.org

THE RACING

led by 30 seconds at the first mark near the Golden Gate Bridge, with Winning's Yandoo in third.

For awhile Hamlin appeared to be running away, but Winning was flying away from everyone else into second place, and as the fleet approached the leeward mark Hamlin's lead vanished.

"They got a puff behind us and sagged down underneath us," Hamlin said. "There was really nothing we could do."

Hamlin slipped to third and soon regained second, but all he could do was to chase Yandoo around for the next two laps, cutting a one-minute gap to 20 seconds while Winning tenaciously covered. The finishing order put the Australian ahead by a point, requiring that Hamlin not only beat Winning in the last race but put one boat between them. But at that point there weren't many boats left. Only seven started, and only three of those finished — Hamlin, Trevor Barnabas and Winning, in that order.

On shore Hamlin said, "I've got to go over and thank Trevor," which he did.

Otherwise, all he could do was sail his own race as most of the others flipped



ERIK SIMONSON/WWW.H2OSHOTS.COM



The 18-ft skiffs sailors turned into impromptu aerialists when this wake from commercial traffic swept the race course at the 18-ft Skiff International Regatta. Kiteboarders, check. Formula boards, check. 18-ft Skiffs, check. Ragtime!, check. Wait . . . Ragtime! Chris Welsh's down-for-any-race-anywhere program took on this year's Bridge to Bridge race, and had probably the driest ride out there.

out of contention. For Winning that came when Yandoo lost it while bearing away during the set at the last windward

mark.

"We were quicker than him downhill," Winning said, "but it was probably just too fresh for us. It was a couple of sensational rides."

GC Marine & Rigging

Stop by our new location now at

BAY MARINE
BOATWORKS Inc. in Richmond



Call us today to ask about...

- **Oct-Nov Special:** Replace your standing rigging and get a free rig tune with pinning and taping.
- Brand new on-site swaging machine handles 1/8"-5/8" wire. All swages are pulled perfectly straight!
- Custom fiberglass and carbon fiber projects for your boat.

gilles@gcmarine.net 415-533-2915
310 W. Cutting Blvd., Richmond



Contact our
new NorCal Rep -
Barry Demak
(408) 905-7245
norcal@opensailingusa.com
to schedule your
demo today!

Pure One Design!

One Design Starts
Now Available on
San Francisco Bay



310-928-6570

www.OPENSAILINGUSA.com



RICH ROBERTS

On the final downwind run before finishing upwind that was all that was on their minds. With all the competition far behind, Allen over trimmed the spinnaker to slow the boat down and maximize stability.

So how does one avoid flipping an 18-ft Skiff when it's nuking?

"Mostly hard work," Hamlin said. "Any one of us could make it flip by doing the wrong thing. I've been doing it 12 years, and these guys grew up here sailing in big breeze. They don't freak out, and we have good coordination and choreography and confidence in one another."

Ronstan Bridge-to-Bridge

For the second year in a row, an 18-footer won the Ronstan Bridge to Bridge race September 3. John Winning's *Yandoo* edged out his son Herman's *Appliances Online* by 38 seconds after sailing the 7.5 mile course that starts just outside the Golden Gate Bridge and finishes just off the west side of Yerba

Buena Island in 19m, 54s.

The race was a counter for the 18-footers' International Regatta at St. Francis YC, which wrapped the following day. So not only were the 18-footers racing the kiteboarders, windsurfers and a newcomer to the event — Chris Welsh's Spencer 65 *Ragtime*, which finished 16th overall — they were also racing each other in the midst of the 59-strong fleet of boats and boards.

It was a tough one for the kitters — only seven of the 30 starters finished. As the fleet passed Pier 39 and made the turn for the finish, they ran out of breeze. After seeing pressure in the mid-twenties at the start, by the time the sailors reached the finish, the breeze had dropped to about five knots.

Catalina 30 Nationals

South Beach YC hosted the Catalina 30 Nationals September 19-20, with 21 boats showing up in three divisions — seven in the spinnaker division, five in the jib and main division, and nine in the cruising division. Although the results are provisional pending protests, at

"That's why we do it," Hamlin said. "It's always tough here . . . the ultimate in skiff sailing. You wake up in the morning stoked, like going to war."

"Like turning on a switch," Allen said.

"The fact that we went through the whole week without flipping is incredible," Noble said.



"The World Leader in
Outfitting Performance Sailors."

BLOG
THE RACK

Apparel
Line
Hardware
One Design Parts
Accessories
Team Gear



Team Gear



Photo Courtesy of Dan Phelps (Spinsheet)

www.APSLTD.com



800.729.9767

THE RACING

at this point Jack McDermott's *Adventure* took the spinnaker division, John Ford's *Avalon* the jib and main division, and Dan Courter's *Ross' Dream* the cruising division. Over the weekend, with 21 boats in three divisions showing up — seven in the spinnaker division, five in the jib and main division, and nine in the cruising division.

"Friday's first race was a near-wash with little wind and a very strong ebb frustrating just about every boat in the competition, with most taking DNF's and motoring back to the committee hoping for better conditions in the second race of the day," said South Beach YC's Jack Ford. "The out-of-towners, girded for our storied heavy weather, came away from the first race scratching their heads, 'Just like home, except for that damn current,' said one So Cal skipper. The second race was greeted by 7- to 8-knots of wind and everyone finished in time for a great BBQ and free beer, compliments of Kame Richards of Pineapple Sails."

The flotilla of Catalinas headed for the start-finish line just off #10 near the end of Treasure Island on Saturday



LESLIE RICHTER/WWW.ROCKSKIPPER.COM

The Optimists sailed their PCCs at SFYC as part of the Leukemia Cup September 19-20.

morning, with race two sending the fleet sailing as far to windward as #7 before turning back to #9 for some downwind rolling, then an even longer course for

race three.

"Both Saturday races were a great introduction to our out-of town friends for Sunday's 'E-Ticket' primer in stuff like 'The Cone', 'Cityfront Frolics', 'Anita Rock' and our local favorite, the downwind flood tide 'drag race' past Alcatraz," Ford said.

"The courses varied on Sunday, but the spinnaker and main and jib divisions took the full tour from a start near number 10 through a walloping flood down to #16. Then, they were off on a real sled ride downwind to #9 near what's left of the Berkeley Pier. The final upwind leg from #9 to the finish was the usual rollercoaster through the barges and the heavy, confused chop of a new ebb banging into the old flood."

In the end, Jack McDermott's *Adventure* took the spinnaker division, John Ford's *Avalon* the jib-and-main division, and Dan Courter's *Ross' Dream* the cruising division.

Olson 25 Nationals

San Francisco Bay dished up its usual

ELLIOTT / PATTISON SAILMAKERS

Because your sail matters!



Antrim 40 "XL" - 1st in Class Crewed Farallones
949 645-6697

Photo by:
Charlie Bergstedt

LA Harbor Area:
Steve Dair 310 619-7245

Marina Del Rey:
Doug Johnstone
310 528-2146

Oceanside: Lee Pryor
760 529-0062



We have a passion for building sails. Call us about your next set.

870 Production Place
(949) 645-6697

Newport Beach, CA 92663

**REPAIR
REPAIR
REPAIR**

**NOW AT
GRAND
MARINA**

ROOSTER SAILS
A REPAIR LOFT

YOUR ROLLER FURLER UV COVER SPECIALIST

ROOSTER SAILS
2021 Alaska Packer Place, Box 18, Alameda
(510) 523-1977
www.roostersails.com • rui@roostersails.com
Open M-Th 9-6 • Fri 9-5 • Sat by appt.
Owned and Operated by Rui Luis • Experienced Sail Repair and Fabrication

NOW OFFERING NEW CRUISING SAILS!
SAIL REPAIR SPECIALISTS • COMPETITIVE RATES • RECUTS • CONVERSIONS

blustery conditions on August 8 and 9 for the Olson 25 Nationals, in conjunction with the J/24 District Championships. On Saturday, winds were into the mid-20s, and in the high teens on Sunday, giving the five entered boats an ideal setting for close competition.

A look at the scoreboard makes it clear that Mark Simpson's *Shadowfax* dominated the series, but tight, boat-for-boat racing was closer than the point breakdowns would imply. In the six-race series, *Shadowfax* took bullets in all but the first race, where she scored a third behind Falk Meissen's *Sharks on Bluegrass* and Steve Smith's *Syncronicity*. "We got all our mistakes out of the way in the first race," said one crewmember.

Meissen's *Bluegrass* team had not pre-



Catalina 30s gathered for the class' National Championships, hosted by South Beach YC.

viously sailed in the ODCA this year, but had a great regatta, demonstrating polished crew work which earned them the second place slot by a broad margin.

OLSON 25 NATIONALS

1) *Shadowfax*, Mark Simpson, 8 points; 2) *Sharks on Bluegrass*, Falk Meissen, 13; 3) *Balin*, Dan Coleman, 23; *Vivace*, Frank Van Kirks, 23; *Syncronicity*, Steve Smith, 26. (5 boats)

PETER LYONS/WWW.LYONSIMAGING.COM

Ballenger Spar Systems, Inc.

**Custom Racing and Cruising Spars
Expert Design and Consultation**

- Carbon and Aluminum spars
- Rod and wire rigging
- Hi-tech and conventional halyards
- Spar kits, extrusion
- Repair and modification
- Custom fabrication, waterjet and CNC
- Hardware, sheaves, spreaders
- Bay Area pick-up and delivery
- **Discounts** on halyards, standing rigging, deck hardware, furlers, Navtec integral cylinders
- 35 years experience!

**Call about Carbon Spars.
Masts • Booms • Poles**

www.ballengerspars.com

**831/763-1196
831/763-1198 (fax)**

Rigging Specialists



SCHEDULING YOUR PROJECTS NOW

- | | |
|------------|----------------|
| • Masts | • Sales |
| • Booms | • Service |
| • Hardware | • Installation |

Please stop by our showroom to experience the difference a knowledgeable rigger can make.

HANSEN RIGGING

(510) 521-7027

2307 Blanding Ave., Alameda

hansenrig@sbcglobal.net

www.hansenrigging.com

With reports this month on **Hints For Overcoming the Recession Blues**, and a special report by members of the Latitude clan on **Family Cruising in the Southern Leewards**.

Itching for a Family Get Away? Scrimp, Save and Be Creative

As we were editing the following piece — about a first-time family sailing vacation — we were reminded of the wonderful trips we took with our own kids when they were young. At the time, those ambitious excursions always seemed like hard-to-rationalize splurges. But looking back now, they gave us some of the best shared memories our family ever had.

In this economy, though, it probably seems tougher than ever to justify taking an exotic getaway, even when you know that doing so is just the therapy you and your family need for the workaday woes of modern living. Here are a few tips that might make a difference.

If money's tight, but you'd really love to get away, try using the technique that your grandparents probably employed in the days before loose credit: carefully analyze where your money goes and find ways to save a buck here and a buck there for the special things you want — like sailing vacations. Forego dinners out for a few months, bring a sack lunch to work and forbid yourself from buying any new clothes. Instead, put the money you save in the charter vacation piggy bank. If you're in the habit of grabbing a latte on your way to work, do the math and you'll see that you could save enough in six months for airfare to

Our kids and their cousins still talk about our 'all-guy' cruise we took — a dozen years ago — exploring Desolation Sound.



LATITUDE / ANDY

Belize, Mexico or British Columbia, just by dusting off your Mr. Coffee machine and brewing your own cup of java.

For travelers on a budget, the next logical step is to pick a charter destina-



tion closer to home, such as those mentioned above. And, of course, consider chartering during the low or 'shoulder' seasons when rates are substantially lower.

You might also take a tip from some Europeans we've encountered, who packed their boat to max capacity with bodies in every berth, including the salon. You won't have a lot of privacy, but if it makes the trip doable, who cares?

If you're a capable skipper with ample bareboating experience, you might take a cue from a couple we know. They often recruit friends who are eager to learn about sailing, but are too inexperienced to rent a boat on their own. Everybody shares food expenses, but the skipper and his wife pay a lesser share of the charter rental fee because they're taking all the responsibility for the boat and planning the trip. The arrangement is always explained up front and no one ever has a problem with it.

Another family we know sat down with their kids and made an agreement that instead of buying mountains of Christmas gifts, they'd spend their money on a holiday sailing trip in the tropics.

In these challenging times you often have to think outside the box to turn vacation dreams into reality, but where there's a will, there's a way.

— latitude/andy



PATRICK SOMERS

A Much-Anticipated Cruise to the Southern Windwards

I have been flirting with the idea of doing a bareboat charter in warm, tropical waters for many years. I've called bareboat yacht brokers the way some people call chat lines. I've promised my daughters that their patience with me and cold water sailing in the San Francisco Bay would someday be rewarded with warm, sublime, turquoise waters — somewhere. And I've convinced our good friends from Bozeman, Montana — Scott, Lori and their daughter Scout — that their money would be well-spent if they joined us.

We finally decided on an ambitious 250-mile, 10-island itinerary in the Caribbean's Windward Antilles that included St. Lucia, St. Vincent and the Grenadines. Once we locked in a reser-

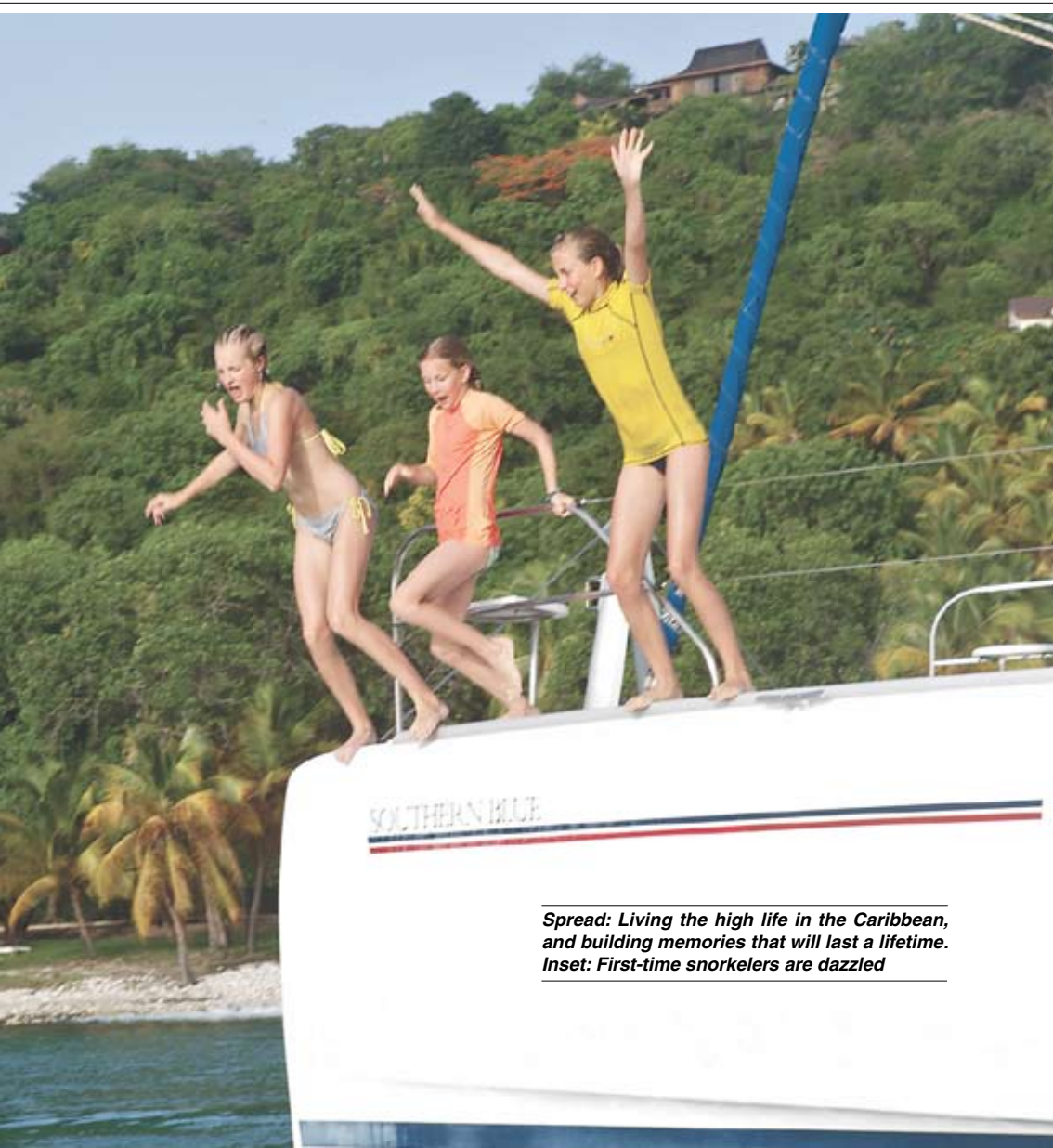

Spread: Living the high life in the Caribbean, and building memories that will last a lifetime. Inset: First-time snorkelers are dazzled

vation on a four-cabin catamaran from The Moorings, we were good to go.

As our vacation dates approached I found myself becoming a bit concerned. I am an experienced monohull sailor and I'd studied the Sailor's Guide and navigation charts for the area thoroughly, but I'd never sailed a catamaran. Add to that a weather forecast calling for an Atlantic Wave to dominate the period of our vacation, with high winds and rain: "Wind NNE 19 freshening 30." We might be in for vacation disaster, I remember thinking, but we were committed.

Some might say that exotic adventure vacations would be better left undone, never embarked upon in the midst of a depressed world economy, but I decided I'd rather spend my hard-earned cash than lose it in some mutual fund!

Fast forward to Marigot Bay, St. Lu-

cia. What a beautiful place to begin. A narrow and intimate inlet with turquoise water, as promised, surrounded by steep volcanic cliffs and a rainforest canopy. Crimson Flamboyant trees contrasted by the deep green of the jungle, and the requisite palms that stood sentry over a strip of white, coral-sand beach.

As the island's forefathers learned, Marigot Bay is a great place to hide an entire fleet of British warships while trying to escape detection by the French fleet. And today, it's a great place to rendezvous with old friends before setting sail on an island cruise.

At the charter base in Marigot, we all enjoyed Alex's chart and boat briefings. Our two wide-eyed daughters thrilled at the promises of wildlife that they'd likely encounter such as porpoise, sea turtles and possibly humpback whales.

My first mate, Laura, and I were more attentive to the cautions of Montezuma Shoal when approaching Mustique, the "keel eaters" around Petit St. Vincent, mooring fees, customs issues and the current feud between two restaurateurs on the island of Mayreau.

Despite a dismal forecast, we had a beautiful morning on Day One, and an auspicious beginning to our cruise. Plus, it was Father's Day. We set off on a short, 12-mile beam reach to Jalousie Bay, which lies beneath Gros and Petit Piton. Both are tooth-shaped, vertical volcanic spires that cast long shadows over the deep azure water of the bay. Thanks to the economic slowdown, we had the place to ourselves.

Before going ashore, we were greeted by two green sea turtles which delighted the girls — none of whom had traveled to the tropics before.

Staff from the Jalousie Bay Plantation Hotel met us at their dinghy dock and treated us as if we were honored guests at their fabulous resort, offering dinghy security, a fine restaurant on the beach, and implied use of their pool and volleyball court, plus a courtesy shuttle up the hill to begin our ascent of Petit Piton.

That ambitious climb was definitely a memorable experience.

As my daughter Madeline later wrote, "There was something magical about Petit Piton. Maybe it was the fact that it is shaped like a shark tooth, or just the fact that it was surrounded by thick, green, lush jungle."

After climbing about 2,000 feet, the trek became increasingly more challenging. As Madeline recalls, "Not long after the first rock course, a second, more dangerous climb unfolded. Even if you'd never been scared of heights before, you would be scared here. The view was beautiful but also breathtaking — breathtakingly scary!"

The next day was to be our biggest sailing day: 65 miles from St Lucia to Bequia in the Grenadines. With easterly trade winds of 20 to 25 knots, and seas that grew to more than 8 feet, the fabled reach across the channel was more 'close' than 'broad' and more pounding

WORLD

than exhilarating. In fact, a few of us discovered the intended use of the heavy nylon line that stretched from post to post on the davits — the barf line!

Once in the lee of St Vincent, everything calmed down, and we could again marvel at the dramatic western coastline, picking out spots such as Wallilabou Bay where the *Pirates of the Caribbean* films were shot.

Admiralty Bay, on Bequia, was the welcome anchorage at the end of that long sail. It had been a challenging trip, but the rough spots were all but forgotten after a refreshing swim, cocktails with dinner and a beautiful sunset.

We all enjoyed exploring ashore, but Sumner, aka Scout, had a particularly memorable experience. She later wrote:

"The day we arrived at Bequia, I knew that this was the island for me. From our cat I could see white sand beaches, colorful buildings and small clothing stalls with wild swirls of sarongs and batiks fluttering in the wind. I was instantly in love with this island that was so apparently full of vibrant, slightly chaotic culture that was so unlike anything I had ever experienced.

"Once ashore, I soon found myself wandering into an open-air vegetable and fruit market that was full of people wearing beanies, with smiles that spread from ear to ear. A large man began telling me why I should buy his fruit. 'Do you see my teeth? Do you know how I keep dem so nice and white?' He smiled, showing off a row of pearly whites. 'My teeth are clean because I eat de fruit, all de time I eat de fruit.' Then to my sur-

The vibrant colors of nature in the tropics capture the imaginations of local residents, who often paint their shops in bright pastel hues.



ALL PHOTOS PATRICK SOMERS & LAURA FORBES

prise, he popped a giant piece of juicy mango into my mouth. This happened repeatedly with other fruit vendors throughout the market until I had met everyone and knew them by name.

"Unfortunately, my name is uncommon and was hard for them to pronounce, so they all decided to call me Queenie. I have to admit, I do like that name."

With customs and immigration, plus last-minute provisioning attended to in Bequia, we felt ready for the next adventure.

Leaving Admiralty Bay toward West Cay, we took our time and sailed as close to shore as possible as the intriguing Moonhole architectural experiment is tucked in behind this isthmus. Windowless housing structures protruding out of the rock or using the rock as structure, it's not for everybody, but very cool nonetheless.

Rounding that point and taking a heading to the southeast, you can begin to see the archipelago of islands that

"We be havin' some fun now!" Cat chartering in the southern Caribbean. Is there really anything not to like about it? Inset: A new friend.

make up the bounty of the Grenadines. Chris Doyle's *Sailor's Guide to the Windward Islands*, respectfully known as 'the bible', cautions one to take some time to make correct IDs of rocks and islands, as depth perception may be impaired, and incorrectly naming an island could obviously lead to trouble.

Winds were up to 20+ knots with relatively big seas as we set an easterly course for Mustique. There again, we had our pick of mooring balls as we settled into Britannia Bay. It felt very good to be there. I think we all shared a long moment of simple contentment.

Harbor patrollers Slick and Chrissy went out of their way to show off their new Harbor Patrol Zodiac and make us feel welcome. Neither trying to sell anything nor gather a tip, they kept returning to our vessel, *Southern Blue*. It wasn't hard to see that they were clearly enchanted by 'the babes' aboard our

OF CHARTERING

boat — our wives, who, although twenty years their senior, still have curves in the right places and abundant beauty.

What I love about sail-

ing vacations is simply of it. I will spare you the who's who of seasonal palace owners there, but in a way it doesn't matter. What matters is how well it appears to function. The Mustique Corporation uses a business model to run the island as if it were a



ing vacations is simply this, control. Control of your food supply, control of your gear (having to unpack just one time), control of your transportation mode, sleeping arrangements (an ocean-view room every night), and to some degree, control of your security. The water is

your castle moat. Plus, of course, the freedom of choice — just pick a heading and go. I love that.

It is also about turning back the clock. Schedules that quickly become ruled by the rising and setting sun. Teaching your kids and reminding yourself about limited resources such as water, food, petrol and, of course, beer. Sharing a small space, boat safety, navigation and seamanship. Best of all, though — and the antidote to our fast-paced home life — is the simplicity. There are few decisions to be made. You might say it's akin to the Club Med recipe, but different because each day's plan is prescribed by us, for us.

The mystique of Mustique: (I'm sure I'm the first to come up with that catchy phrase.) At some point in our pickup-truck tour of the island, Scott christened Mustique "perfectville." Distinct from all the West Indies that I have come to know, this place has got it together! It's pristine, yet charming; well ordered and still relaxed. The thread, of course, is money and lots

country. The BOD as parliament, CEO as king, CFO as the minister of the treasury, and, of course, all the lords, ladies and landed gentry have seats on the Board. I get it, corporations actually are the new monarchy. The Corporation, however, is allegedly merciless when it comes to misbehavior of a misdemeanor variety or worse. You will be thrown off the island and not welcomed back.

On a recommendation, we dined the first night at Firefly, then enjoyed a dark and windy walk home, getting lost enough that the jungle around us grew ominously in my 11-year-old's mind. The threatening shadows and the jungle noises contrasted with the fact that only 10 minutes ago she had been seated in an elegant restaurant.

More in line with our budget and quite enjoyable, with an equally dramatic top-of-the-hill view, was Lucy's barbeque, where we ate the next day. It also offered outdoor patio dancing.

We sailed off the mooring at Mustique by simply raising the main while still tied to the mooring, after everything had been made ready to get underway.

A quick note to

all you catamaran virgins: If you're a cat-curious monohuller (like I was) who is considering stepping over to the 'dark side' via a bareboat charter, I can tell you that although we had our challenges, we found the cat easier to handle than a similar-sized monohull, especially when motoring, due to the cat's twin screws. By jockeying the throttles, you can hover in place, despite the wind, while your crew fusses about trying to pick up a mooring ball or set an anchor. With one engine in reverse and one in forward, you can spin on a dime.

Cats are also much more stable platforms, of course. I found it to be not only easier to handle, but also more comfortable. The kids loved the trampoline, and somehow we got used to their being out there in 8-foot seas and 23 knots of wind.

Cats are vastly superior if you plan to transport gear, scuba or otherwise. That said, the sailing is not as sexy or as much fun. And, in my humble opinion, most cats are not as beautiful to view at anchor or when underway.

Horseshoe Reef and the Tobago Cays National Park beckoned us, but we first made a stop at The Moorings' facility in Canouan for room service (a change of linens and refill of our water tanks). This was quite a convenience.

The plan was to push just a little south to Petit St Vincent and Petit Martinique, then lolligag northward with, theoretically, a better sense of where to spend time. In this part of the Grenadines interisland distances are short, and inviting anchorages are plentiful. Our plan served us well.

Our one regret was being blown out of the Tobago Cays. On the southbound leg

For newcomers to these latitudes, the cultural exchanges while shopping were part of the fun.



WORLD OF CHARTERING

we arrived in the evening, again enjoying the option of many different moorings. We found our spot, moored up in the midst of frothy skies and seas and made plans for a thorough diving investigation of Horseshoe Reef the following day. Unfortunately, it blew hard all night with no sign of abating in the morning. So we retreated, and found wind protection at Salt Whistle Bay on Mayreau, another lovely Island and anchorage. That was it, though, for us and the Cays, as conditions were about the same three days later on the northbound leg.

During our exploration of the Grenadines we had many more adventures, including an ascent of Gros Piton before returning our vessel to the charter base.

Our voyage was topped off by a return to Jalousie Bay Plantation Hotel to luxuriate and celebrate our time together, this time as a mere landlubbers.

Oddly, I was envious of the sailboats at anchor in Jalousie Bay as I eyed them from the resort beach. They were probably just beginning their bareboat voyage — or perhaps were in the second year of



PATRICK SOMERS

"Pirates ye be warned!" For the 'Southern Blue' crew, it was a thrill to sail in waters where actual pirates once had roamed.

a circumnavigation. Having just sampled a bit of short-term cruising myself, that thought gave me something to dream about for future adventuring.

— patrick somers

Ten Things Not to Miss — From a Kid's Perspective

- Definitely, the snorkeling: it's amazing
- Jump off the boat doing cool tricks: good photos
- Collect lots of shells: very pretty
- Pick coconuts. It's a lot of fun climbing up the trees: great views
- Try to crack open a coconut by yourself: bragging rights
- Buy Caribbean clothes: cool duds
- Play charades every night: you'll go to bed with happy, fun thoughts
- Learn how to 'drive' the dinghy: a whole lot of fun
- Skinny dip at night: great fun
- Don't fight with siblings because you will be embarrassed later and also get into a bad mood: always be happy in the Caribbean
- One for good luck: Have a flabbergasting adventure!

— natalie somers

Right Equipment! Lowest Cost!

**Price Guarantee
BEAT ANY OFFER
BY \$100!**
Call for Details

**Save 15% on your
next Footloose
getaway!**
Call for details
or visit us online

**Footloose
SAILING CHARTERS**

www.FootlooseCharters.com
888-852-4666

NORTH AMERICA | CARIBBEAN | MEDITERRANEAN | SOUTH PACIFIC | INDIAN OCEAN

BAREBOAT | CREWED | SKIPPED

WHERE QUALITY OF SERVICE,
MEETS QUALITY OF LIFE.

Our 40-year reputation for integrity, quality and reliability has satisfied the most discriminating sailors. Trust The Moorings. We promise our quality of service will enhance your quality of life.

Visit the most trusted name in chartering
www.moorings.com
800-521-1198

The Moorings[®]
The Best Sailing Vacations In The World!
1969 - 2009

Real People. Real Sailing. Real Fun.

Sail Cats | Power Cats
Monohulls | Trawlers
Bareboat | Skipped

Real Choices.

Choose CYOA and become part of the family. We've been providing beautifully maintained yachts, personal service and sensible prices to sailors since 1980.

1-800-944-2962
info@cyoacharters.com
www.cyoacharters.com
St. Thomas USVI 00802



CYOA
YACHT CHARTERS

"We had a true, worry-free 14 days of sailing. We got everything we asked for... and then some!"

BVI Yacht Charters Guest

- Bareboat, Crewed or Skipped
- Monohulls from 31' to 52'
- Catamarans from 36' to 47'
- Provisioning service available
- Tailored and personal service
- Private Marina
- ASA Instruction
- 24 Hr Emergency Call Out
- Yacht Brokerage
- Beneteau Fractional Programmes
- Free Wifi & Customer Computer

Boatshed BVI.com

Call us on 284-494-4289
or visit www.bviyachtcharters.com



BVI YACHT CHARTERS

www.bviyc.com

THE BOATS. THE SAILING. THE EXPERIENCE...

'Electronic Latitude

**Get Your Midweek
Sailing Recharge at
www.latitude38.com**

ANACORTES YACHT CHARTERS PACIFIC NORTHWEST ADVENTURES

Largest Selection of
Charter Yachts in the
Pacific Northwest

Bareboat &
Skippered

Power and Sail
28'-66'

Charter Yacht
Ownership

Yachting &
ASA Sailing Schools

*Book now for 2010
Early Birds get up to 15% off 2009 rates*



www.ayc.com 800.233.3004

**Closest full-service
charter base to
Desolation Sound &
Princess Louisa Inlet**

Visit our Website
for a preview
of our 31' to 54'
Power & Sail fleet

**BOOK NOW
& SAVE!** *It's not too early to
plan next year's cruise!*

charter@desolationsoundyachtcharters.com
www.desolationsoundyachtcharters.com

#101-1819 Beaufort Ave., Comox, BC, CANADA V9M 1R9
TOLL FREE 1-877-647-3518 FAX (250) 339-2217

What's a summer day's cruise
in the Pacific Northwest?

How about 17 hours of daylight!!!

- San Juans
- Gulf Islands
- Desolation Sound

**Bellhaven
Charters**
Power & Sail Charters
Crewed or Bareboat
ASA Sailing School
Power & Sail Yacht Sales

www.bellhaven.net
bellhaven@bellhaven.net
877-310-9471

BELLINGHAM, WA

HAWAII

LONG TERM DRY STORAGE

Clear Customs at our dock

**GENTRY'S
KONA MARINA**

HONOKOHAU HARBOR

156°1'30" W
19°40'20" N

TOLL FREE **888-458-7896**

www.gentryskonamarina.com

The friendliest boatyard in Hawaii



**YACHT CHARTERS IN
GREECE, TURKEY
AND CARIBBEAN**

Best Rates For Reliable Charters
Full services: Low fares, hotels, tours, transfers

Visit our website for
yacht photos and details,
destinations and itineraries:
www.albatrosscharters.com

**SAIL AND
SCUBA DIVING
IN GREECE**

Sailboats • 30'-60'
Bareboat/Crewed
Monohulls & Catamarans
Luxury Sail & Motor
5 to 60 Guests

Albatross
*An American owned
and operated company*

(800) 377-8877
(856) 778-5656
Box 250, Moorestown, NJ 08057



**NEED
CASH
FAST?**

Advertise your USED MARINE GEAR
in our *Classy Classifieds*
THIS STUFF SELLS FAST!
Deadline is the 18th at 5pm. See page 174 for details.

**BRITISH VIRGIN ISLANDS
"BEST DEALS ON KEELS"**



- Most selection of sailboats 32'-52'
- "Purr" with cats 38'-47'
- Bare boat or skippered
- Best yacht management program

**Conch
Charters**
Est. 1986

**NEW
YACHTS IN
FLEET!**

www.conchcharters.com
Email: sailing@conchcharters.com
Call our 'Sails' Office
(USA) (800) 521-8939
Tel (284) 494-4868 • Fax (284) 494-5793

Sail paradise with Conch Charters

CALIFORNIA'S CARIBBEAN CONNECTION



**Sail Mexico Aboard the
Schooner Seaward Winter 2010**

**Answer the 'Call of the Sea'
Adventure Voyages to
Mexico's Sea of Cortez**

**Contact us
now! Limited
Availability!**

Be part of the adventure. This is a hands-on opportunity for all levels of sailors to enjoy the pristine beauty of Baja and camaraderie with your shipmates.

Channel Islands from Los Angeles	Jan 5-10	\$1,000
Los Angeles to Cabo San Lucas	Jan 14-26	\$1,350
La Paz to Cabo San Lucas	Feb 19-24	\$1,100
Cabo to San Francisco	Feb 24-Mar 13	\$850

www.SeawardAdventures.org • (415) 331-3214

These trips share the educational spirit of Call of the Sea's mission and help support our Youth Programs. *Seaward* is an 82-ft USCG-inspected vessel owned by Call of the Sea, a non-profit educational organization.

www.SeawardAdventures.org • info@callofthesea.org



Tortola BVI
Belize
The Grenadines

**UNIQUELY
TMM**

Most charter companies offer blue water & palm trees, but it takes the personalized care of people like Marisa to make your vacation a success.

Like Marisa, everyone at TMM is committed to your complete satisfaction. Our specialized three-location operation offers large company quality with small company service. A combination that is uniquely TMM.

TMM
Yacht Charters
Since 1979

catamarans • monohulls
motor yachts
ownership programs

Marisa
TMM Belize

CHANGES

With reports this month from the traditional Polynesian cat **Manu Rere** at Makemo in the Tuamotus; a long report from **Geja** on cruising Italy, Slovenia and Croatia; a long report from **Toucan Tango** on buying a cat in Malaysia and cruising to the Med via India; from the **Blue Water Cruising Club** luau at Catalina; and a full helping of **Cruise Notes**.

Manu Rere — 38-ft Catamaran Glenn Tieman Makemo Atoll, Tuamotus (Oxnard)

I stayed at Makemo Atoll in the Tuamotus for five weeks. In retrospect, it was preferable to spend the month-long Bastille Day celebrations there than



Glenn, looking shady.

at the more crowded and more expensive Papeete, the capital of French Polynesia. At Makemo there were sporting contests during the day, and competition between two traditional *heiva* dance groups at night. Each group made their own music. Their instruments were mostly a variety of elaborate drums and hollowed ringing logs. I really enjoyed it. The famously sexy Tahitian dancers were, of course, also a pleasure to see. Even their costumes were beautiful. When the celebrations wound down and I prepared to depart, a small cut in my finger became viciously infected. It required antibiotics — free from the dispensary — and a couple more weeks to heal. My traditional Polynesian voyaging cat has no mechanical advantages, so I couldn't sail with a messed up hand.

Once I finally raised the hook, I sailed 20 miles across the lagoon to anchor near the other pass. The coral patches were so brilliantly colorful on the way over that they were easy to avoid. Since I was then away from town, I was able

'Ontong Java' in Polynesia. If she looks like a yacht you might like to own, contact Hans at gowest@yahoo.com.

to stock up on coconuts — which are a regular part of my diet now — without having to worry about ownership issues. I then rode the ebb tide out the pass and set sail for Tahiti.

After sailing past several atolls the first day, then through a stretch of open ocean, I hove to for the night while still 25 miles short of the narrow passage between the last of the Tuamotus. The current has long been known for being strong and unpredictable in the so-called 'Dangerous Archipelago'. I would have to for most of the other nights on the passage to Tahiti as the weather was so stormy. After this, I was happy to see beautiful Tahiti come into sight, and to anchor in the quiet shelter of the headland and breakwater at the small town of Tautira.

After several pleasant days at Tautira, I sailed for Papeete, expecting it to be a pleasant and scenic daysail. Instead, I would learn firsthand about the *maramu* winds, which accelerated around the island. At first I dropped all sail to await the passage of what I took to be a squall. But when I analyzed the wind direction, it appeared to be blowing me toward the nearby shoals. So I hoisted a storm sail — which laces on the main mast — for the first time ever. Powered by this tiny sail, I made my way behind Venus Point, off Papeete, and into the lee of the island the next day. I was glad to drop the anchor again.

The way I see it, Papeete is for buying things you can't find elsewhere in French Polynesia. It serves that function well. Every day for a week, I hiked into town to discover where things were and to buy food, propane, boat parts and finally a French language textbook. I also did take time to visit some beaches on the way.

My sail from Tahiti to nearby Moorea was also stormy, with the wind coming in too strong after a long morning calm. It reminded me of Hawaii. While at Moorea, I met Hans Klaar on his one-of-a-kind 73-ft traditional voyaging double canoe *Ontong Java*. Hans was one of the first Westerners to use crab claw sails — such as I have



ALL PHOTOS BY ANDREW VIK

on *Manu Rere*. He used them on his Wharram catamaran and is using them on his current boat — which is probably the only yacht more radically stone age than mine. Although Hans does use a 5-hp outboard engine on his cat, she was built on Polynesian lines from big planks cut from two trees in West Africa. The gaps between the planks are sealed with strips of rubber tacked over the planks.

There are some people on Moorea who appreciate Polynesian vessels such as my *Manu Rere*, and they kept me entertained with dives, tours and meals. When I later returned to Papeete, I got an email from Hans saying he was at Moorea, had one too many girls aboard, and hoped I could take one. The women were beauties, too. Unfortunately, I'd already cleared out of the country, so I was moving on to Huahine and Bora Bora, my last stops in French Polynesia. Despite its drawbacks, Bora Bora looks like the Matterhorn jutting out of the sea and mist. While in Bora Bora, I again crossed



GLENN TIEMAN



goon, we spent a night tied outside Trattoria da Lazarini in the town of Burano. This town is the colorful little cousin of Venice, where the beautifully painted buildings are reminiscent of Mexico's most colorful villages. At sunset we experienced the wildest hailstorm that this San Franciscan has ever seen. One-inch diameter hail pelted *Geja* for 20 minutes, with thunder and lightning crackling just overhead. By the time I had set out the cocktail glasses to harvest the ice, the hailstorm ended. Mariners definitely must keep an eye on the weather when cruising the Med — even in the middle of summer.

Great times in the Med. Spread; beautiful Ist, Croatia. Top, left to right. Andrew near a bridge at one of the smaller canals in Venice. A strange ultra-modern, Russian-owned motoryacht, said to have cost about \$300 million. Croatian girls just wanna have fun. And lovely but quiet Piran, Slovenia.

paths with *Ontong Java*. I've already met up with the crews of several other Wharram traditional catamarans.

From Bora Bora, I have a 1,500-mile passage to Wallis Island and possibly Samoa. Then I'll sail north through Tuvalu before the start of the South Pacific tropical cyclone season.

— glenn 09/01/09

**Geja — Islander 36
Andrew Vik
Another Summer In The Med
(San Francisco)**

I can't believe that my second summer of Mediterranean cruising aboard *Geja*, the '76 Islander 36 that I first learned about in a September '06 *'Lectronic Latitude*, has come to an end. I covered some 1,500 amazing miles in the Adriatic Sea, visiting Italy, Slovenia and Croatia.

As of my last update in the August issue, I'd reached Venice, far north

in the Adriatic. I splurged and stayed six nights in the Sant'Elena Marina, a scenic 30-minute walk from St. Mark's Square. The highlight of my first ever trip to Venice was zipping through the myriad of canals, both large and small, on *Geja's* nine-foot Zodiac tender. I even made several passes under the famous Rio Alto Bridge in the Grand Canal. The first day wasn't so smooth, however, as crewmember Lars and I managed to get busted for entering a forbidden military zone, and collided with a gondola full of tourists. Who knew that one must pass a gondola starboard-to-starboard instead of the normal port to port? By day two, however, we were navigating harmoniously with the gondolas, sometimes becoming stuck in huge gondola traffic jams to the sound of accordion music and singing gondoliers.

Before leaving the Venice La-

Leaving through one of three exits from the Venice Lagoon, we observed the massive and controversial construction project intended to seal the lagoon from the Adriatic Sea. Unlike the rest of the relatively tide-less Med, the northern Adriatic has a tidal range of three feet, and it can be reinforced by strong southerly surges in the winter. Venice itself now floods more often than

Despite some language barriers, Andrew made many friends, including lovely Tamara, the second runner up in Austria's 'Next Top Model'.



CHANGES

ever. Many yacht harbors in the region already have built their own flood control gates to deal with the surge.

Italy's nearest coastal neighbor to the east is Slovenia, the only E.U. member



From Ibiza, Spain, to Zrce, Croatia, Med girls love to party.

From the former country of Yugoslavia. The highlight of its 20-mile coastline is the wonderful harbor town of Piran, where the architecture and winding streets reminded me that this entire region was under Venetian rule for hundreds of years. But Piran is a quiet town with little nightlife, and even the neighboring party town of Portoroz had little to offer at the height of peak season. When young Slovenians want serious summer fun, they head south to Croatia, which was the next and final country of my journey for the summer.

Croatia is not part of the European Union, and the check-in procedure, though not horribly inefficient, still requires stops at multiple agencies and purchase of a 200-euro cruising permit that's good for a year. (The Italians, on the other hand, couldn't be bothered that a U.S.-flagged boat entered their waters from a non-E.U. country). Once checked in, we had great sailing down the Istria Peninsula, stopping in Porec and Rovinj before reaching Pula, site of an amazing First Century Roman coliseum. It's said to be the best preserved Roman coliseum in the world. Boats may anchor just in front of the coliseum, providing a backdrop possible only in the Med.

Nordic friends Henriikka and Johanna joined me in Pula, and we continued

The spectacular view of Hvar, Croatia, from the castle above the town. The eastern Adriatic couldn't be more different from the western.



to have great sailing among the islands of Croatia's Kvarner Gulf. The gulf is known for its tricky weather and sudden storms. In fact, it's where you find Senj Bora, which is the Croatian version of The Slot on San Francisco Bay. The waters between the islands of Rab and Krk are subject to offshore winds that tend to funnel strongly from the mainland town of Senj at the northern end of the Velebit mountain range. These winds have completely stripped the nearby islands of vegetation, and in winter often blow in excess of hurricane force. For us, the wind gradually built to about 30 knots, with stronger gusts. It was a wild but safe beam reach, particularly after Henriikka climbed on top of the house and reefed the main.

As nice as an all-female crew can be, we split up for the next two weeks. I left the girls at Riviera-like Opatija, which is a posh resort town that was developed in the 19th century for Austrian aristocrats. As for myself, I was joined by wingmen Ville and Sven. We sailed south to the island of Pag in the notorious Santa-Ana-like bora winds. We made several great stops on the way, and even transited a centuries-old canal, the 20-foot wide Osor Canal. It was dug by Liburnian tribes prior to the Roman settlement! But our two weeks revolved around the island of Pag and Zrce, its 24-hour party beach. It's Croatia's answer to Ibiza.

When we got to Zrce, we couldn't believe our eyes, as there were thousands of young people filling several open-air nightclubs on the beach. Papaya, one of them, attracts top DJ's from around the world. The parties at the clubs start in the afternoon, with beach-clad hotties dancing and splashing in the pools while sipping supersized cocktails from one-liter carafes. Come sunset, everybody heads home to eat and rest, returning again at 1 a.m. to start to party.

As more and more Italians made their usual August migration across the Adriatic, Zrce became more a sausage fest, somehow attracting more Italian males than females. It was time for a bit of detox anyway, so with new crew Maggie and Lukas, I set sail for calmer shores. As we arrived in obscure Olib, a local port official caught our lines. He didn't just ask how long we planned to stay, but asked it in English with



a perfect New York accent! Islands like Olib and Susak have strong ties to the U.S., as folks have been migrating back and forth for more than a century. Some even have an Americanized Croatian dialect. Vacationing American families dominated tiny Olib, so it's there I heard the most English all summer.

Heading farther south among the outer Croatian islands, we visited Kornati National Park, which is a dense archipelago that's been deforested over the years by Venetians, shepherds and fire. The starkness was in great contrast to Croatia's typically forested islands, but the lack of trees and brush made for excellent hiking and vistas. With aft winds, we had a blast broad-reaching a zig-zag course, using the numerous islands as a slalom course, while chicken-jibing between the outer and inner waters.

We continued south to the mainland party town of Vodice, where we caught some late-season action at high-profile clubs Hacienda and Aurora. Croatian

IN LATITUDES



ALL PHOTOS COURTESY GEJA



Smashing Melissa, one of Vik's 16 crew.

From lower left: Five gals for every Vik in the dinghy. Italian summer hail. The coliseum at Pula. Lovely crew Maggie channels Hollywood. Andrew with the girl band Eni. The falls at Krka National Park. Delicious fresh fruits and veggies. Outside a sub pen. 'Geja' tied up at the fortress at Sibenik.

girls never ceased to impress me and my crews with their amazing good looks. The girls on the Dalmation Coast are tall and lean, and they love to flaunt their figures with short skirts and high heels.

After an exhausting weekend at the clubs, new crewmember Alex and I took *Geja* 10 miles up the Krka River into the fresh waters of Skradin, gateway to the Krka National Park. The Krka River cascades down countless waterfalls on its way to the Adriatic. The park is a great — but crowded — place to spend a day soaking in fresh water.

My final crew of the season were Anja and Melissa of San Francisco. Ten of our friends got so jealous that they chartered a 51-ft Elan, which was a bit of a slow boat. We buddy-boated for the week through the now familiar-to-me waters near Split, and I showed them my favorites spots, such as Hvar Town and the

Blue Cave. We experienced mostly ideal early-September weather, with breezy afternoons and calm nights. The water temperature was still near 80 degrees.

In all, I spent about 80 days actively cruising during my second summer in the Med, and made 60 stops. My crew — I had 16 different people over the summer — and I spent about 34 nights at anchor, 25 in marinas (blame Italy), 11 on town quays, and 10 other nights 'creatively' moored. We sailed half of the 1,500 miles, and put another 200 hours on the engine.

Despite being 33 years old and having suffered the wear-and-tear of being sailed two-thirds of the way around the world, *Geja* performed

flawlessly. The *Islander 36s* are so nice to sail, as they are steady, well-behaved and have a light helm. And unlike 'modern' boats with flat bottoms, they don't pound when sailing upwind. *Geja's* Yanmar diesel is solid, her sails are more than decent, and she has all the coastal cruising equipment one needs — such as refrigeration to keep the beer cold. *Geja* proved to be a popular boat in every port, with countless people inquiring about her San Francisco hailing port.

I'm now back in Split near *Geja's* winter home, where I'm spending a final week anchored for free just in front of the 'Riva' of this lively student town — which happens to be on UNESCO's World Heritage list. Live bands perform for me nightly on the promenade, and there is still plenty of nightlife despite the premature end to summer weather. How can I go wrong in a town where even the local tourist brochure describes the "fine lookin' ladies" of Split as having "amazing height and ample bosom?" I'll be hauling out in a couple of days. It will be sad, but with all the recent crappy weather, the water temperature dropped from 80 to 70 in just one week.

For those who might want to cruise here, most Italians speak only Italian, while Croats and Slovenians speak great English. It makes the Italian experience more exotic, but getting things done in Italy can be very frustrating. The main mechanic in my winter boatyard in Croatia speaks both English and German at a very technical level. The low '*Geja*' anchored at Zavrtnica, Croatia. It sort of looks like the Sea of Cortez, but with twisting fjords. The water temp was 80 degrees.



GEJA

CHANGES

winter rates and English proficiency make Croatia a *much* better place to have work done — and meet girls. Although



Vik's new friend Marija at Solaris Beach.

I wouldn't accuse either of being very punctual!

What are my plans for next summer? Well, Greece is just down the road, isn't it? I hadn't planned on making a habit of these extended summer vacations in the Med, but I love the cruising over here so much!

And I've yet to tire of the cruising experience — at least as long as the weather is good. Last night's thunderstorm, while I was on the hook, was intense. This morning I had to pump six inches of water out of the dinghy. But yes, I'm certainly thinking of coming back next summer.

The thing I enjoy most about cruising is sharing the experience with my international assortment of friends and acquaintances, while exploring a continent where people truly know how to enjoy life.

— andrew 09/15/09

Toucan Tango — Catana 47 Cat Marvin and Ruth Stark Malaysia to Turkey (Folsom)

When I was 59, my wife Ruth and I did the '97 Ha-Ha with our F-31 trimaran *Noor*. When we got to Cabo, Ruth said, "If we're going to do this again, you'd better

A young girl from one of the hill tribes in Thailand. Doctors are mystified at why she complains of a chronic sore throat.



TOUCAN TANGO

get a bigger boat." So three months later we bought a used Catana 44 in France, and christened her *Chesapeake*. During the next six years, we would sail her 25,000 miles to San Francisco Bay, where we sold her in '04. So *Latitude*, a fine magazine, is partly responsible for our laid back lifestyle. By the way, I'm glad to see that the magazine and the publisher still have the same attitude.

In '08, at age 71, with my new titanium hip, Ruth and I decided to make one more sailing trip. So last year we flew from Sacramento to the island of Langkawi, Malaysia, where we bought *Toucan Tango*, an '01 Catana 47, which is one of the best cruising catamarans made. She has a 200-liter fridge, a 100-liter freezer, a washing machine, watermaker and king-sized beds. The eight bimini-mounted 75-watt solar plates handle all the power requirements on a daily basis. We run an engine or generator only if we're on a long passage and are using lights, the autopilot and navigation equipment. With her daggerboards down, she sails really well to windward — at least for a catamaran.

We spent our first six months — meaning the summer of '08 — cruising Malaysia and Thailand. Summer is the wet season, so there was lots of rain. Squalls tested our ground tackle and anchor a couple of times with winds to 40 knots. The Northeast monsoon winds started kicking in around December, at which time the weather became drier, so we set off on the 1,500-mile passage across the Andaman Sea to India. It was great sailing, with mostly light winds and smooth seas. We even flew the spinnaker for a couple days. We had a maximum of 22 knots of wind until we rounded the tip of Sri Lanka. Based on poor reports from other cruisers, we did not stop at Sri Lanka.

When you turn the corner at the tip of Sri Lanka to head 240 miles to the southern tip of India, you pass through the Gulf of Mannar, during which time you'd better damn well be hanging on! Most boats that passed through there encountered headwinds to 35 knots and ugly seas. We spent one day and two nights with triple-reefed everything. We could not sit at either steering station without getting a fire hose shower from every second wave. We huddled in the cockpit behind the cabin, clutching the remote control for the autopilot. *Toucan Tango* bashed, smashed, crashed, twist-

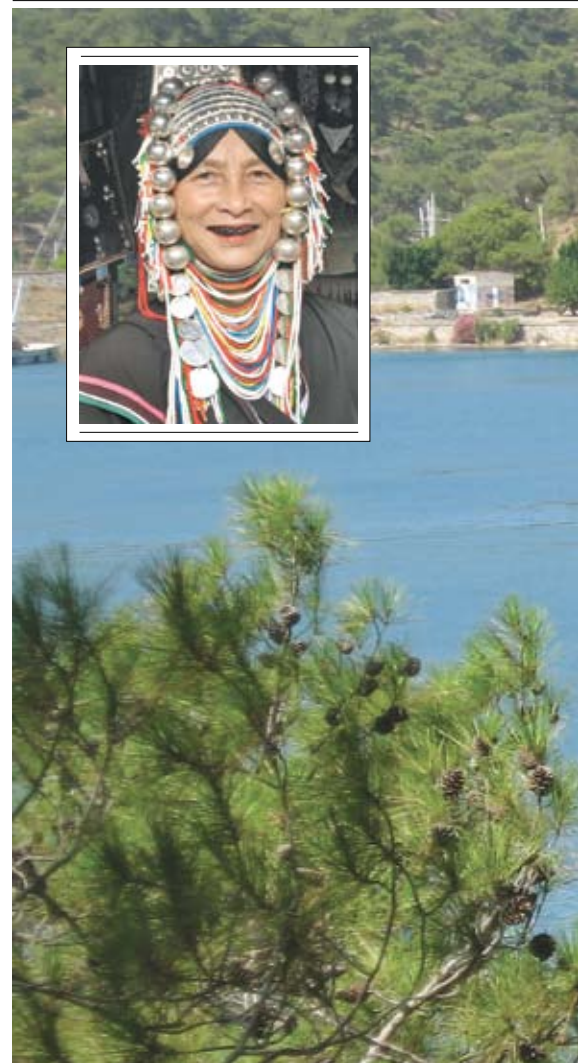

ed and torqued through the mess. But boats sure are tougher than humans. A smaller Leopard catamaran lost her entire bow tramp during the maelstrom.

When you reach the southwest tip of India, you have it made. We had smooth sailing the rest of the way into Cochin. Our clearance was handled at Willingdon Island next to the Taj Malabar Hotel, after which we were directed to anchor in the river near Bolgatty Island. Water was available at the island for a small fee by jerry can, and we could get Wifi — but at a high fee.

The Indian people were friendly, and the women wear beautiful saris. The Indians have a way of moving their head sideways back and forth when you ask a question, such that you don't know if their answer is yes or no. If you ask the tuk-tuk driver, "Do you know where Kingfisher Airline office is?", all you get is a wobbling head, no matter how many times you ask. It can mean yes or no. If you get into the wholesale district of the

IN LATITUDES



PHOTOS COURTESY TOUCAN TANGO

Spread; 'Toucan Tango', the Catana 47 the Starks bought in Malaysia last year. Insets: An older Thai woman, Ruth and Marvin.

city, you will see men carrying sacks of produce, rice, bananas or concrete that are heavy enough to stagger an ox.

Eating out was unbelievably cheap. Ruth and I had lunch at a nice air-conditioned restaurant and the total bill came to 85 *rupees* — which is about \$1.70 U.S. The next day I had a 10-course lunch, all I could eat, for \$1.60 U.S. There are no Wal-Marts or super stores in this part of India, and all shops are very small and very basic. In one, for example, we found an old bicycle wheel used as a tool to make rope from coconut husks. When you buy some *paratha*, which is a delicious local flat bread, it comes wrapped in old newspaper. You can buy handmade hoes or shovels made of all steel that will last a lifetime. It jars my teeth just thinking about them!

When we were at Bolgatty Island, there were about 20 other sailboats

anchored out. They flew the flags of the UK, the U.S., Australia, South Africa, Germany, Holland, France, Canada and several other countries. Many were part of the Vasco de Gama Rally that takes the fleet from Thailand to Turkey. Most are doing an around-the-world trip.

In this part of India, it was pleasant and comfortable in the countryside, where people live in simple harmony with nature. Most have running water or wells, and even electricity and television. The name of the state is Kerala, which literally means the land of coconuts. And there are plenty of coconuts, bananas, mangoes, papayas and everything else that grows. However, Cochin harbor/river, where we anchored, is no garden spot. And Cochin itself is crowded, chaotic and dirty.

One of the main seaports of India, Cochin is

home to 600,000 people. The traffic is unbelievable, with countless buses rocking around at full speed while spewing diesel fumes. There are lots of other vehicles, and each one has a horn. And I mean a really loud horn, a horn that is sounded incessantly. If, for example, there is a small traffic jam, everyone who is stuck in it lays on their horn until everyone starts moving. Then they go back to intermittent honking.

The three-wheeled tuk-tuks all have horns, and some are driven by absolute wild men. They drive on both sides of

the road, think nothing of bouncing over the sidewalk, and won't give an inch. But you can ride across town for \$1 or less. The tuk-tuks reluctantly shared the streets with large busses, trucks, small cars, motorbikes, push carts with huge loads, and finally, pedestrians fearing for their lives.

We only crossed the street where there was a divider. Even then, we'd

wait and look carefully before dashing across traffic to the safety of the other side. You can usually get through a few motorbikes, and maybe a tuk-tuk or two, but don't try bluffing anything bigger. It is so dusty and dirty that we usually had to take a shower as soon as we got back to the boat.

After a month in Cochin, in February we headed another 1,500 miles west across the Indian Ocean to Salalah, Oman. The northeast tradewinds blew from the west for two days, then from the northwest at 10-15 knots for most of the

The famous cantilever fishing nets of Cochin. The nets extend 60 feet into the river, and are counterbalanced by heavy rocks for lifting.



Morning tuk-tuk traffic was light.



SHEENA RONSON

CHANGES

rest of the trip, dying down to very little wind near Salalah. Checking into Oman is easy, and all done at the commercial port while one's boat is at anchor. There is good shopping and provisioning in Oman, although no alcohol or pork. Oman has oil, so it's neither poor nor backward. We rented a car at the port



A coalition gunner aims to protect yachts from pirates.

and looked around for a few days. The 600-mile stretch of ocean from Salalah to Aden is considered Pirate Alley, and is where Somali pirates have captured several ships and ransomed their crews and contents. The coalition forces, made up of several nations, now have 20 warships patrolling this area. Some have helicopters. They have established a two-day, 5-mile wide transit corridor about 60 miles offshore. Ships are requested to transit this area in convoys, and to move at a speed of at least 10 knots. We cruise at six knots, so we sailed. We talked to the warships two or three times on VHF, and had two helicopter flyovers. We also had the spinnaker up the last day and were making five knots when a helicopter asked if we couldn't go any faster. At one time a ship just eight miles from our position reported being attacked by pirates. Two hours later, he reported that he had successfully repelled the pirates with high pressure fire hoses by motoring at flank speed. Repelling AK-47 rifles and rocket launchers with fire hoses?

Sana'a, Yemen has a different look and feel from most capital cities. While there, the Starks stayed in a hotel that predates Jesus.

After arriving safe in Aden, we anchored in the bay for almost a month in order to tour inland. This was an important place to set our anchor well because it blew a lot. The highlight of the stay was a three-day trip up into the mountains to the ancient Yemen capital city of Sana'a. What a spectacular city full of friendly people! There are narrow streets with shops selling local handicrafts and clothes, and numerous restaurants and food stalls. We stayed in a 2,000-year-old hotel that had small wooden doors and uneven walls. The new Lulu's shopping mall in Aden has everything — except, once again, alcohol and pork — that you might need for provisioning, and at a fair price. We really got hooked on the delicious baklava, which is a pastry made with honey and pistachios. Everywhere we went, the people were friendly. Seeing we were Americans, many would say, "Obama OK."

We headed for the Red Sea in early March. As we rounded the straits of Bab Al Mendeb — Gate of Tears — the wind picked up to 35 knots. We triple-reefed both sails, and made a solid 10-12 knots flying downwind. Yahoo! We had planned to anchor in a bay in southern Eritrea, but we passed it, as we were sailing so fast that we wanted to keep going. The wind slowly dropped, and so the next night we anchored in a very nice bay with warm, clear water. When transiting the Red Sea, it's easy to stop and anchor every night.

Fishing in the southern Red Sea is spectacular, and we caught fish almost at will. We landed three large fish one day, and ate fish for breakfast, lunch and dinner. But caution, you will lose all your tackle rated at less than 100 pounds. The winds in the southern Red Sea tend to blow from the south. It gets light halfway up the sea, and becomes increasingly strong from the north as you get farther north. If you're patient and don't mind tacking, you can sail almost the entire way. We did.

We eventually cleared into Eritrea at Massawa, side-tying to the concrete wall at the commercial port. It had excellent security and water, but no power. We made a two-day bus trip up to the capital city of Asmara. You ride five hours through the desert and desolate



countryside, then eventually up a windy mountain road that takes you up to over 7,000 feet. The city of Asmara is like being transported to an Italian city, complete with sidewalk cafes and pizza restaurants that serve beer. The outdoor central market requires a least a full day to appreciate. There is great leather work and other handicrafts.

(To be continued next month.)

— marvin 09/15/09

Luau Time Blue Water Cruising Club Geiger Cove, Catalina

Sailing was very different 70 years ago. For example, not that many folks in Southern California had boats. And back then, a 26-footer was considered a big sailboat. What's more, it was common for boats not to have engines. Nonetheless, the intrepid sailors and their friends would cruise to Catalina and up to the Channel Islands. With the start of World War II, things took a sudden change for the worse. For in addition to the trag-



IN LATITUDES



ALL PHOTOS LATITUDE/NICK



LATITUDE/NICK

The club's facilities are ultra spartan, just the way the members like it. The 'clubhouse' is small and so basic that it doesn't even have electricity. The one luxury is a gravity fed shower. But there are some BBQ rings in the cove, a swing for the kids, trails, and some shaded tables. It's all guarded by Geiger, the ferocious dog who watches over the cove when none of the members are around.

Oh, to be young and swinging at Geiger.

Last month we were invited to the club's big luau, which is their swan song event of the summer. About 40 boats packed the cove so tightly you could have passed the Grey Poupon from one side of the anchorage to the other. Some 150 members and guests came ashore. In an authentic luau, you cook a whole pig in the ground. But since that takes a long time, and nobody wants to bring a dead pig across from the mainland on his/her, the Blue Water Cruising Club did a modified luau that featured big chunks of pig and beef, as well as whole tuna.

For the last 15 years, the luau 'chef' has been Don Young, who took over the duties after George Geiger passed away in the '90s. You couldn't envision a more perfect guy for the role than the tan and trim Young, who continues to live the sailing and surfing life, and who looked authentic in the lava lava he picked up during a charter trip to Tonga. Young not only did the TransPac this year aboard the Catalina 42 *Carpe Diem*, but he did

Luau guest Zuzana Prochazka of the Celestial 48 'Indigo' surveys the tightly packed anchorage at Geiger Cove just before dinner.

Clockwise from above. Luau chef Don Young, looking fine in his lava lava, tends to the pit. Dick Landes and Tim Weissenberger serve up the meat. Asst. chef Kris Rittenhouse, in fireproof flip-flops, works the pit. The beach scene at Geiger. Ellen Rittenhouse samples husband Kris's cooking.

edy of war itself, private boats weren't allowed outside the L.A. Breakwater. So the sailors used to hang out in L.A. Harbor and — according to one source — drink a lot.

Once the war was over, sailors couldn't wait to get back out to Catalina. So a group of them formed the Blue Water Cruising Club. Their big event of the year was a luau, which they would hold at a different cove on the island every year. By the '50s, Catalina was starting to get crowded, and groups were getting leases on the various coves. The honchos at Blue Water settled on Geiger Cove, in large part because the wind usually holds all the way into the cove, making it ideal for boats without engines. At other coves on the island, it could take two days to sail the last two miles.

There are some interesting things about the Blue Water YC. First, it's a club for sailors — although older members are

allowed to switch to powerboats. Second, unlike most coves at Catalina, there are no moorings at Geiger. Boats anchor fore and aft, and are packed together more tightly than Antigua during Sailing Week. Despite how jammed the little anchorage gets during the busiest weekends, we're told there is never a discouraging word. Not even when a foul wind comes up and everyone has to bail out of the anchorage. Third, outboard-powered dinghies are not allowed in the anchorage in order to maintain the peace and protect swimmers. As a result, most members have Avon Redcrest dinghies, as they are perfect for rowing the very short distance ashore.



LATITUDE/NICK

CHANGES

the delivery back, too. (He's got some advice for Catalina 42 owners — don't attach the tack of a gennaker to the anchor roller.)



With motors not allowed Redcrests are popular at Geiger.

Preparing for a luau is like painting a boat, in that it's the preparation that takes most of the time. Thankfully, there had been plenty of helping hands to dig the hole, line it with rocks, and prepare the banana leaves and gunny sacks. After three hours in the aromatic pit, the meat, fish and potatoes were cooked to perfection. This was a good thing, because when you're cooking in a pit as opposed to an oven, you just can't take out the food to see if it's done, and slide it back in the oven if it's not.

Anyway, it was a great event with great people at a great cove on a Sunday of perfect Southern California weather. Just like the old days.

— *latitude* 09/05/09

Cruise Notes:

It gets really hot in the Sea of Cortez in the summer, and toward the end of summer it gets both very hot and very humid. So what do cruisers do to cool off? There are a number of strategies, but Anthony Diliberti, who did the '07 Ha-Ha with his Seattle-based Ta Chou 51 **Mandalay**, explains how he does it in La Paz: "First, we chill the beer. Then we clean the dinghy and fill it with water. Finally, we get in the dinghy, pop open a cool one, and use the dinghy like a

"Come on in, the dinghy-pool is cool!" Figuring out a way to stay cool in the summer in the Sea of Cortez is very important.



bathtub." He didn't mention how long it takes before they need to add ice to avoid being parboiled.

For as long as we've been editing *Changes in Latitudes* — and it's been more than three decades now — cruisers have complained about the harbor at **Pago Pago, American Samoa**. Thanks to the two fish processing plants, the harbor has always been ugly, dirty, smelly and noisy. And the officials weren't always the most helpful. Thus, some cruisers took to referring to it as the 'armpit of the Pacific'. But there are big changes underway that will hopefully improve Pago Pago's image and make it a more attractive destination for cruisers. Samoa Packing, whose 2,500 workers made it the biggest employer on the island, has shut down. In response, the Governor says he's determined to clean up the harbor — and with it, the town's tawdry image. As it's on the South Pacific Milk Run from Tahiti to New Zealand, and as it's a U.S. Territory and therefore gets U.S. Mail and goods and services, Pago Pago has a couple of things going for it. To add to that, \$2 million — of U.S. taxpayer money, of course — is being spent on a dock for cruising boats and a security fence. A private company has also been given a 10-year lease to develop the yacht basin even further. A large budget has also been allocated to developing tourism in the nearby Manu'a islands, and to refurbish the historic RainMaker Hotel. But what no amount of money can change is the fact that Pago Pago, home to only about 12,000 people, is one of the wettest inhabited spots on earth.

Pago Pago used to have an aerial tramway to the highest peak, which afforded a beautiful view of the harbor. Alas, on Flag Day in '80, a U.S. Navy plane that was part of the festivities struck the tramway cable, and then crashed into a wing of the Rainmaker Hotel. The tram still hasn't been repaired, and the now government-owned hotel is dilapidated. According to one review on the internet, "The Rainmaker Hotel is frequented by government officials on often dubious business. If you are one for novel experiences, then stay here for a few nights, as you'll likely meet some interesting characters and have a few sto-



ries for back home." Anyway, we wish the folks in Pago Pago the best of luck in making the changes. To make sure there is no confusion, American Samoa is entirely different from the **Independent State of Samoa**, which was formerly known as Western Samoa. The latter is not a territory of the United States, and by most accounts is better for not having become a welfare ward of Uncle Sam.

"*Latitude* is famous in windy Spanish Waters, Curacao," write Veronique Bardach and Ted Halstead of the D.C.-based Catana 50 catamaran **Verite**. "That's because you guys are the custodians for the Pacific Puddle Jump, and the PPJ is all the rage at the bi-weekly happy hour for cruisers here who will be doing the South Pacific. So we had to check out the PPJ site for ourselves. Wow, pretty damn impressive! We're going to try to participate if we can. After getting interviewed by the publisher of *Latitude* in St. Barth just before New Year's, we hit many of the other islands in the Lesser Antilles. Most recently, we had a blast in Mustique, and we loved

IN LATITUDES



COURTESY VERITE

Spread; The Catana 50 'Verite' storming along beneath the Pitons off St. Lucia. Inset; Ted and Veronique, who hope to do the Pacific.

Martinique and the Los Roques Islands of Venezuela. But nothing compared to St. Barth. While cruising down here, we met a really cool Italian couple our age who, like us, have a Catana 50 but don't have kids. They are also kiteboarders. In fact, some years back he was the Italian water ski champion, and this year she won the European Barefoot Waterskiing Championship. We plan to cruise across the Pacific with them. Bet you guys didn't think we'd 'make it.' Heck, we were wondering ourselves."

Ted and Veronique's cruising commitment had indeed looked a little shaky there for awhile. They'd bought their expensive cat new in France last summer, and having had little cruising or even sailing experience, had assumed that there wasn't much more to it than adding fuel, water and food, and taking off on a carefree lifestyle. But they're both smart and both big lovers of ocean sports, so we were confident they'd make

it. Since the couple did start their cruise in the Med, we're going to share their thumbnail opinion of sailing in that part of the world:

"For us, the biggest draw to sailing in the Med is the diversity of cultures and the great food and entertainment. You just don't find that in the Caribbean. Sailing itself in the Med is feast or famine, however, as there is either too little or too much wind. Our one overriding complaint about the area is that it's usually so crowded in the summer. But with the world economy having been in shambles, we found most places to be largely empty when we were there."

Bruce Balan and Alene Rice report that they and their California-based Cross 45 trimaran **Migration** are about to leave Taha'a, French Polynesia, for New Zealand. It's not that they don't like French Polynesia, they just aren't interested in spending the South Pacific cyclone season in the cyclone zone — even in a seldom-hit part of the zone. You

might remember that the couple spent nearly a month at Rapa Nui, a.k.a. Easter Island, when they sailed there from the Galapagos in the spring of '08. They put together some comprehensive information about where to anchor at Rapa Nui in various wind and sea conditions, so if you're planning on sailing there, you might contact them at AE6XT@winlink.org. Keep your message short.

As *Latitude* readers know, Scott and Cindy Stolnitz of the Marina del Rey-based Switch 51 catamaran **Beach House** are accomplished and relentless scuba divers. And they've continued



The moai are the iconic figures of Rapa Nui.

diving after sailing to French Polynesia. "We had a fantastic week diving with a parade of sharks in the south pass of Fakarava," writes Cindy. "The diving is so easy, and the dive master has been so busy that he's basically let us and our friends Dan and Jill dive on our own. The dive master has the boat driver drop us off at the right spot, and we get to do our own thing without getting stuck with a group. It's been terrific, for in addition to plenty of sharks, we've seen gorgeous fields of coral, every size and shape of tropical fish, and every dive has been an hour or longer. There have only been two things wrong. One time we had lunch at a local restaurant between two dives, and while we didn't starve, the food was barely edible. For example, one offering was Spam pizza and another was fish quiche. Yuck! Jill later saved the day by bringing out some Trader Joe's chocolate-covered almonds that she'd brought from the States. The other problem **Cindy has been messing with sharks ever since she and Scott started their cruise. These white tips sleep all day and hunt all night.**



SCOTT STOLNITZ

CHANGES

lem has been my ear. But the other day Steven, an M.D. on the sailboat **Uliad**, was kind enough to make a 'boat call' to *Beach House* to examine my ear. After one look, he said there was no mystery why I couldn't hear well. Using an ear curette, he pulled out a bunch of wax. He also instructed me to, after coming out of the saltwater, rinse my ears with mild soapy water using an ear bulb. He recommended that I continue to use alcohol or vinegar/peroxide drops. It was weird and somewhat jarring to be able to suddenly hear clearly out of my right ear again."

Here's a 'what are the chances?' story from the South Pacific, as reported by Keith, no last name, commodore of the Niue YC in the tiny nation of Niue in the South Pacific. According to Keith, the crew of the vessel **Dosis** was anchored off Beveridge Reef — which is mostly submerged and is in the middle of the ocean — when they visited a nearby boat for "drinkies". When it was time to head back to their own boat, the crew discovered the dinghy and outboard had drifted away. After an extensive search



NELSON MONDALE

Had the dinghy from 'Dosis' not been found by a fisherman, it would have been slammed to bits on the rugged coast of Niue.

at first light, nothing was found and it was given up for lost. *Dosis* continued dinghy-less to Niue, stayed awhile, then left for Tonga. Miraculously, three weeks later the boat's dinghy and outboard

were discovered by a fisherman just 150 feet from going on the jagged rocks of Niue. Somehow it had drifted several hundred miles from Beveridge Reef right to Niue. And the engine still worked. That left just one problem — how to get the dinghy and motor to *Dosis* in Tonga.

Speaking of Niue, while perusing the Niue YC newsletter, we discovered that Steve and Susan Chamberlin of the Pt. Richmond-based Schumacher 46 **Surprise** haven't owned up to something they did there. When the couple stopped at Niue about a year ago, they were discouraged to see that only eight of the 30 computers at the Niue High School tech labs were working. Asking how they could help out, the senior math instructor suggested they could perhaps assist in getting some of the computers repaired, or even buy the school a new one. The Chamberlins said they'd see what they could do, then sailed away. A short time later, they offered the high school sufficient funding to replace all 30 computers with new ones! On further investigation, the folks at Niue High were





We help make
El Salvador
worth the trip!

Visit our Web site
www.barillasmarina.com
to learn more about our
many amenities including
high speed Internet,
on-site customs and
24-hour security.



Barillas Marina Club is the premier cruising destination in El Salvador. We are Located in Jiquilisco Bay, the largest Bay in El Salvador. Make Barillas Marina Club your headquarters in Central America and experience the difference that makes us a preferred destination.

www.barillasmarina.com
(503) 2675-1131 • info@barillasmarina.com

THE RELIABILITY'S BUILT IN!



HONDA
MARINE
PROVEN



All boats powered by Honda Marine engines.

We offer complete service on all Honda outboards and inflatable boats and take pride in providing the kind of customer satisfaction that you expect from Honda.



The Dinghy Doctor

1271 Scott Street
San Diego, CA 92106
Tues-Sat, 9am-5pm
(619) 304-6921
www.thedinghydoctor.com

2 blocks
off Shelter
Island

- BF20**
- Unsurpassed fuel economy
- Shallow water drive
- Largest displacement in its class (21.4 CI)
- Hi Output alternator (12 amps)

AB, Achilles, repair kits, engine parts, and everything you will need in Mexico.

Always wear a personal flotation device while boating and read your owner's manual.

dismayed to learn that they couldn't just buy 30 computers and plug them in, they would also need a new server, software licensing, a network upgrade, additional RAM for each computer, plus technical support from New Zealand to install the whole system. More big bucks. According to the Niue YC newsletter, Steve and Susan weren't fazed at all, and happily agreed to cover those additional costs, too. While it took months to order all the stuff, the whole system was ready to go for the start of the '09 school year. Brilliant. We apologize to Steve and Susan for outing their generosity, but found it too inspiring to resist.

If you're cruising to Australia, don't expect marine items to be cheap — or even reasonably priced. For example, '08 Puddle Jumpers Bill and Judy Rouse of the Houston-based Amel Maramu 52 **Bebe** report that the oil absorbent pads that many fuel docks and marinas give away free in the States, and which you can buy in bulk here for as little as 60 cents each, sell for as much as \$14.95 each in Australia! And that the 5 and 20

micron pre-filters that they paid \$6.97 for at Budget Marine in the Eastern Caribbean, cost \$20 each in Australia. "Had we known such basic items were going to be so expensive in Oz, we would have stocked up before leaving New Zealand," they write.

Jeff Stander of the Seattle-based Kelly-Peterson 44 **Beatrix**, currently in Bundaberg, Oz, has an explanation. "Australia is a great place with great people, but they're still stuck with the same archaic distribution system of importer/distributor/retailer/end user. It makes purchases ridiculously slow and expensive." Stander writes that marine supplies and other stuff are often 50% to even 200% more expensive in Australia than in the U.S.. But he's

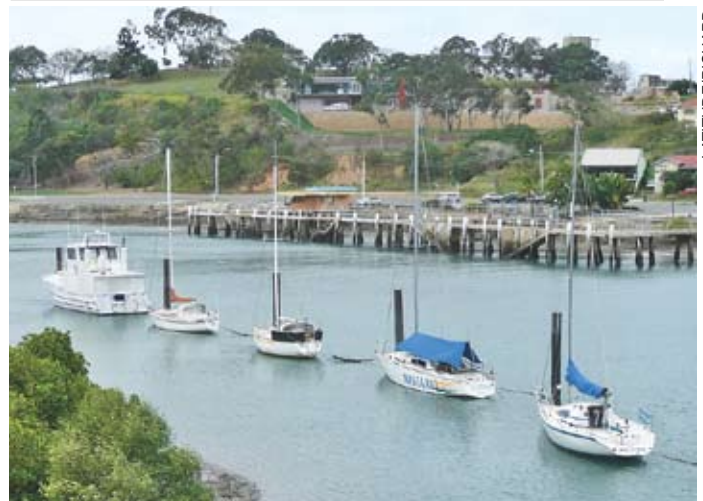

Australia has a lot of things going for it — including pile moorings in most rivers — but low prices aren't among them.

figured out ways to work the system. For instance, using the internet and eBay, he was able to buy watermaker pre-filters for less than the Rouses paid for them in the Eastern Caribbean. He also has marine stuff sent via U.S. Priority Mail from Seattle to Bundaberg at the flat rate of \$51 for 20 pounds. It takes only five business days, and can be tracked



Increase Your Solar Output With Solar Boost™ MPPT Solar Charge Regulators

Get All The Power You Need To Weather Any Storm

The Solar Boost™ 3024i & 2000E are two of the most reliable Solar Charge Controllers on the market & our patented technology extracts all the power your solar panels can deliver, up to 30% more!

Blue Sky Energy Inc. gets rave reviews in Practical Sailor. Read the article at www.blueskyenergyinc.com

800-493-7877 or 760-597-1642
2598 Fortune Way, Suite K, Vista, CA 92081 USA
E-mail: sales@blueskyenergyinc.com
Web: blueskyenergyinc.com

**San Diego Seminar
October 22
Downwind Marine
(see www.downwindmarine.com)
Solar/Battery
Charging Systems**

QUALITY....RELIABILITY....BLUE SKY ENERGY, CHANGING THE WAY SOLAR IS USED EVERYDAY

CHANGES

via the internet all the way into and out of Australian Customs. It's allowed him to save more than 25% on things like shower pumps.

All this helps explain why we got a phone call the other day from a fellow in Perth, Western Australia, inquiring about the original mast for **Profligate** that we have for sale. When we expressed surprise that it could make financial sense for him to buy our mast, which is currently located in Santa Barbara, and ship it half way around the world, he assured us that it very well might. After all, he told us that his other main option was to buy a Selden mast made in Denmark. Couldn't he have a mast made in the sailing centers of Sydney or Auckland and and shipped to Perth for much less? "Not necessarily," he replied. "It's often less expensive to have something shipped to Perth from Europe than it is to have it trucked here from Sydney."

Could this be the solution to your **health insurance costs**? "Some Americans are moving to Mexico in order to get IMSS, which is Mexican Social Security health insurance," writes Philo Hayward. Philo did the Ha-Ha aboard

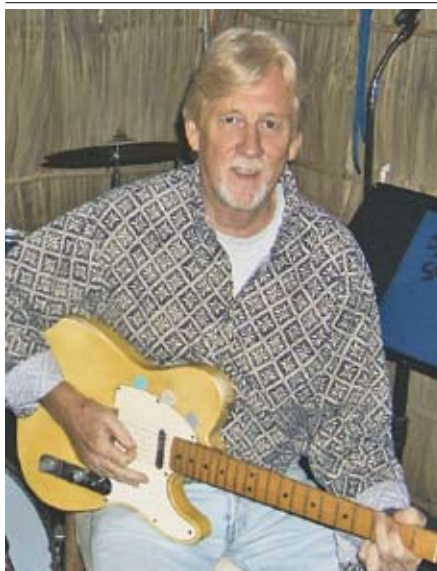

LATITUDE/NICK

Philo, seen here with his favorite guitar at his place in La Cruz, has IMSS health insurance. You might want to get it, too.

his Mendocino-based Cal 36 **Cherokee** in '00, and despite buying a music venue and bar in La Cruz on Banderas Bay, continued cruising across the Pacific until he sold his boat in Vanuatu. For

the last seven years or so, he's run the extremely popular and community-oriented Philo's bar and music studio. In his last newsletter, he refers to a September 1 *USA/Today* article about IMSS, which is Mexican social security health insurance, and which can be purchased by Americans with the proper visa. Although the coverage is good only for treatment in Mexico, it is said to cover everything — including tests, medicines, x-rays, eyeglasses and even dental work. There is no deductible, and it apparently costs a flat fee of less than \$300 a year. Now that's what we call affordable health care! John Skoriak of the Marine Exchange in Sausalito reports that there are a variety of other low cost health insurance and health care options in Mexico.

Putting some speed into their cruising! Bruce and Nora Slayden of Sisters, Oregon, did the '04 Ha-Ha and '05 Puddle Jump with their Island Packet 485 **Jamboree**. But we heard they were on the Bay over the Labor Day Weekend with their new — and much faster — ride. She's the Gunboat 66 **Sugar**

**ENJOY 5 STAR
RESORT AMENITIES
AT \$10.40 PER FOOT**

	Foot	ANNUAL Price/ft in other Marinas in Southern CA	ANNUAL Price/ft in Hotel Coral & Marina Ensenada, Mexico	ANNUAL SAVINGS!
		\$17.00	\$10.40*	
Slip Size	45	\$9,180.00	\$6,291.00	\$2,889.00
Slip Size	50	\$10,200.00	\$6,990.00	\$3,210.00
Slip Size	55	\$11,220.00	\$7,689.00	\$3,531.00
Slip Size	65	\$13,260.00	\$9,087.00	\$4,173.00
End Ties	64, 79, 95, 99, 109		\$12.00*	

* Plus tax

The only fuel dock & best launch ramp in Ensenada
Concrete docks from 30' to 65' with 100v / 220v elect.
Water, cable tv & phone hookups, free wireless internet
Laundry, marine chandlery
Shuttle service available to and from Marina Coral - San Diego (Shelter Island area)



**HOTEL CORAL
AND MARINA**

Reservations toll free: 1 (866) 302-0066 | F 01152 (646) 175-0058 | VHF 71 | Carretera Tijuana-Ensenada Km. 103, No. 3421 Zona Playitas, Ensenada, B.C. C.P 22860 | marina@hotelcoral.com | www.hotelcoral.com



McGinnis Insurance

Since 1972

Knowledge  Commitment
Reliability  Service



Large and small, we do them all!

Call us at: **800-486-4008**

meginnsins@aol.com

License #0570469

Daddy, a totally high-tech cat designed by Morrelli & Melvin. A lot of catamaran manufacturers stretch the truth when they talk about the speeds of their cats, but a Gunboat 66 has no trouble hitting speeds in the 20s. The Slaydens are apparently going to haul out in San Diego in October, then set sail for Hawaii and the Line Islands, then cruise Australia for a year.

Rob and Lorraine Coleman, who started cruising out of Berkeley ages ago on the Columbia 30 **Samba Pa Ti**, report they have sold **Southern Cross**, their wood Angleman gaff ketch that was designed in '37 and is currently in New Zealand. You don't want to sell a classic yacht like that to just anyone, so the Colemans were fortunate that the new buyers are Ed and Stacy McDonald, who currently own a small sistership.

"If you get on Google Earth," the Colemans write, "and zoom in on the north side of the pass on the east side of Fanning Island, you'll see a rectangular barge. If you zoom in really tight, you can see *Southern Cross* tied up to the barge. And if you have really good

resolution, you may even see Lorraine and Borau cleaning the day's catch of five octopus. It's cool."

We know how cool that is because we like to zoom around and see what boats we can find at popular anchorages and marinas in Mexico. For example, when we zoom in at La Cruz, we can see Bob Smith's Vancouver-based custom 44-ft cat **Pantera** on the hook just outside the marina. And moving over to Paradise Marina, it's easy to pick out David Crowe's San Jose-based M&M 70 cat **Humu Humu**. We can also see **Profligate** at Paradise Marina — and on the hook at Catalina's Harbor Reef. Who says a boat can't be in two places at the same time? The latest version of Google Earth is much faster than it used to be, and in many areas the resolution is much



The marinas at Nuevo Vallarta courtesy of Google Earth. With a few clicks on your mouse you 'visit' every anchorage in the world.

greater than just a short time ago. It's a great navigation tool, too. For example, zoom in on Punta Mita, and you get a great view of where the underwater rocks are.

Nearing the end of a 15-year circumnavigation — albeit a much interrupted one — are Kirk, Cath and son Stuart

Your Boatyard in the Heart of Paradise



Large, fenced, secure dry storage area

Tahiti Customs policy has changed!
Foreign Flag vessels can stay on dry storage in our yard for up to 12 months out of 24.

Our Services |

HAULOUT

- Marine Travelift 25 tons
- Marine railway 120 tons
- Storage in adjustable steel cradles
- Fenced Yard

PAINTING

- Topsides, hull, bottom, varnish
- Brush, roller, spray

MECHANICAL WORK

- Inboard, outboard, diesel, gas
- All brands

REPAIRS

- Electrical repairs
- Refrigeration installation & repair
- Fiberglass & woodwork
- Welding, steel, stainless, aluminum

SAIL LOFT

- Sail repairs, biminis, dodgers, covers

STORE

- International, Pettit, Epiglass, Devoc
- Spares
- Fill U.S. gas cylinders

DO-IT-YOURSELFERS WELCOME!

BoatUS Cooperating Marina



Professional boatyard in the heart of Paradise



A Subsidiary of
The Moorings Yacht Charter, Ltd.

*Raiatea Carenage will make sure
paradise is everything you expected.*

Call, write, or sail in . . . we're here to serve you.

B.P. 1111 Uturoa Raiatea 98 735 Polynésie Française

Tel: (689) 600-545 ~ Fax: (689) 600-546 ~ VHF 68

Web site: <http://www.raiatea.com/carenage> ~ email: raiataecarenage@mail.pf

CHANGES

McGeorge of the Virgin Islands-based Hylas 47 **Gallivanter**. "After five months in French Polynesia, we've made it back to Tahiti for one last provisioning while anchored at Marina Taina in preparation to begin back-tracking to the Marquesas via the northern Tuamotus," the family reports. "We were going to set sail this morning, but last night we were raked by savage winds gusting to 56 knots. It caused our anchor to drag — and our home right along with it! The savage winds came in three waves of intense squalls, and during the seven hour period we never had less than 20 knots. At least four vessels were driven onto the bricks, and I saw two genoas unfurl and get shredded in a matter of minutes. If you haven't been in such conditions, here's how to get an idea of what it was like — stand in the back of a pick-up doing 65 mph offroad at night in the rain, then try to lasso a rhino. We had to pick up 300 feet of chain and a 65-lb anchor, re-position out in the channel, reset the hook, then stay up all night making sure we were holding fast. I'm talking about full throttle maneuvering



JULIE TURPIN

Making landfall in Hawaii will complete a circumnavigation for Kirk McGeorge, but not his wife Cath or his son Stuart.

in a very tight space! We were inside a lagoon, so thankfully we had only wind waves to deal with. Unlike some boats, ours came through undamaged, but we

were exhausted. Provided the weather settles, we'll head off tomorrow on the 200-mile leg to the Tuamotus, the 550-mile leg to the Marquesas, and finally the 2,200-mile leg to Hilo. Somewhere along the way we'll celebrate our son's 6th birthday. When we arrive in Honolulu, we'll be able to connect the dots on our globe and cross our outbound path that began 15 years ago on the Islander 37 pilothouse I bought from ex-San Diegan Carol Post in Honolulu."

Last year Gary Burgin and his dad Larry did the Ha-Ha aboard their Santa Cruz-based Marples 55 catamaran **Crystal Blue Persuasion**, as the first step in going to Mahahual, which is 180 miles south of Cancun on the Caribbean coast of Mexico, to set up a charter business. They made it to Mahahual before Christmas, which means they really jammed. That was all well and good, but starting a charter business hasn't worked out as they had hoped. "Business in Mexico is not what it's played up to be," says Gary, noting that just about everybody had their hand out for a cut of the action.

Welcome to Mazatlan...



Marina El Cid style!

A CRUISER'S PARADISE IN THE HEART OF MEXICO'S LUSH TROPICAL COASTLINE AND BEAUTIFUL ISLANDS

Complete, Modern Amenities, Including Marina-Wide High Speed Wireless Internet Connections!



www.elcid.com
011-52 (669) 916-3468
gcevallos@elcid.com.mx

The Cruiser's Home in Mexico

MARINA REAL

SAN CARLOS, SONORA, MEXICO

IN THE SEA OF CORTEZ

Located on the Mexican mainland near Guaymas and San Carlos, 265 miles south of Nogales, Arizona.

- 350 slip marina • 20 & 30 amps electrical service
- 24-hour security patrol
- Fuel dock with gasoline/diesel
- Restrooms & showers
- Web email • Fax/copy service
- Port entry clearance
- Book exchange • Video loan library
- Ice & bottled water
- Wet storage for summer months (low prices)

**Now Offering:
Haulouts, Dry Storage & Service Yard**



Phone/fax 011-52-622-2270011
Call on VHF #16 when in area
email: marinareal@prodigy.net.mx

Visit our website:
www.marinareal.bravehost.com

Worse than that, the transmissions on both engines went out. "Don't ask," says Gary — but it forced him to fly back to California to have a yard sale to raise the money to pay to get them fixed. Then a motor froze up while at Isla Mujeres. At least, he says, it was a nice place to be stuck. Right now Gary is looking for crew willing to share expenses on a trip back to California. He can be reached at gduwb@msn.com.

As we reported earlier this year, **St. Barth** — the cleanest, safest and most upscale island in the Caribbean — took a horrible economic hit during the winter high season as a result of a combination of yet another year of unbridled price increases, a weak dollar and the severe downturn in the global economy. As a result, we weren't surprised to receive an email from our *bon ami* Luc Poupon, announcing that the little St. Barth YC, in concert with Saint Barthélemy's Collectivité, will be hosting a new sailing event, the four-race **Les Voiles de Saint Barth**, to be held April 6 to 11. The event will be open to maxi yachts, classic yachts,

racing boats and multi-hulls. The timing of the event couldn't be better, as it comes almost immediately after the wildly successful St. Barth Bucket, which is limited to sailboats over 100 feet, and just before the Antigua Classic Yacht Regatta and Antigua Sailing Week, which are held at 85-mile distant Antigua. If you'll be chartering a boat out of St. Martin during this time, you won't want to miss it — even if you're just a spectator for a race or two. For complete information, visit www.lesvoilesdesaintbarth.com.

Speaking of St. Barth, Mike Harker of the Manhattan Beach-based Hunter 49 **Wanderlust 3** was there in early September, and the quay, the inner harbor moogings, and the outer Gustavia



If you like really big boat racing, St. Barth will be the place to be during the Bucket. And for all boats during the new Les Voiles de St. Barth.

anchorage were all but deserted. What a difference off-season makes.

For those headed to **Mexico** this winter, the following is a list of the major organized activities. Most, but not all, are some combination of 'nothing serious' racing and fund-raising. We at *Latitude* support all of the following:

Your secret paradise...

in
Nicaragua

Located in a beautiful sheltered lagoon on the north Pacific coast of Nicaragua, Marina Puesta del Sol is your premier cruising destination in Central America.

Marina Puesta del Sol
RESORT

Aserradores, Nicaragua ♦ 011 (from US and Canada) 505-880-0019
mpuestadelsol@yahoo.com ♦ www.marinapuestadelsol.com ♦ USA 408-588-0017

¡Hola! **Baja Ha-Ha Cruisers**
Before You Baja Ha-Ha, Stay at Chula!

Baja Ha-Ha Cruiser's Special
Up to 3 months at \$16 per foot
FREE Liveboard for 2
Subject to Availability

First-class yacht marina amenities
at a reasonable price
Gourmet restaurants...Heated pool & spa

We're your best value on the Bay in San Diego

CHULA VISTA MARINA
619-862-2819
550 Marina Parkway • Chula Vista, CA 91910
www.chulavistamarina.com
boatslips@cvmarina.com

CHANGES

Banderas Bay Blast, including the Pirates for Pupils Spinnaker Run — December 2-4. Co-sponsored by the Punta Mita Yacht & Surf Club and the Vallarta YC, this event features three days of destination racing, with stops at Punta Mita, La Cruz and Paradise Marina. There is no entry fee, but it is a fundraiser.

Vallarta YC Chili Cook-Off — December 5, the day after the Blast. This is the Vallarta YC's biggest fundraiser of the year. Held at Paradise Marina.

Subasta, presented by the Club Cruceiros de La Paz — December 6. Now in its 21st year, this is the club's biggest fundraiser, and coordinates with the respected Fundación Ayuda Niños La Paz, A.C. (FANLAP), which fights the good fight for the truly underprivileged kids of La Paz. The money raised is used to buy kids the basics such as toothbrushes and toothpaste, shampoo and soap, socks, underwear, and school supplies. Last year 400 simple Christmas presents were bought for kids who otherwise wouldn't have even gotten a piece of coal.

Zihua SailFest — February 2-9.

Conceived on a whim by the publisher of *Latitude*, thank goodness a series of more serious and responsible people took charge, and over the years have turned this into a stunningly successful cruiser fundraiser for local schools.

Sea of Cortez Sailing Week — early April. 'Nothing serious' cruiser racing from La Paz to Caleta Partida to Isla San Francisco and back. It's free, but it's fundraiser, too.

Loreto Fest, Puerto Escondido, Baja — early May. The big cruiser gathering in the Sea of Cortez includes four days of fun and fundraising.

Lots of cruisers like to make contributions on a personal rather than group level. For instance, when Wayne Hendryx and Carol Baggerly of the Brisbane-based Hughes 45 **Capricorn Cat** were in Mexico last year, they met a woman named Pat at Casa Fresca in one of the small Banderas Bay communities. Pat teaches local women how to sew, and she's desperately in need of a sewing machine. Any kind of sewing machine.

If you can help, contact richard@latitude38.com, and we'll see that it gets to her. Wayne and Carol are also collecting clothes that are in good condition for the kids aged 2 to 10 at the orphanage in Bucerias, as well as pens, pencils and paper for the school kids. The stuff you never use or that you think of as junk, can have tremendous value for children in Mexico, some of them who literally live in city dumps.

Remember, too, that parts of Baja were hit badly by hurricane and later a tropical storm **Jimena**. If you've got room on your boat, try to bring something along for those folks, particularly the kids. Our only caution is to be very careful when giving cash to charitable organizations, for just as in the United States, the money often ends up in the wrong pockets.

On August 31, *Lectronic* reported that 63-year-old Jim Cheshire of the Alberg 35 **Godot** was overdue on a singlehanded passage from Ecuador to the Marquesas. His family has since reported he's fine. We hope you're fine, too, and that this will be your year to go cruising.

SAVE
on North Sails
quality, durability
& performance!

NORTH SAILS
direct

It's easy to measure your own boat
and SAVE on the world's best
cruising and racing sails. Log on to
northsailsdirect.net
or call 888-424-7328.

Free tape
measure
with every
order!

Come to Mexico and repair your boat at

OPEQUIMAR
MARINE CENTER CENTRO MARINO

Puerto Vallarta

**88-ton (max)
Travelift!
Length to 100'
Width to 23'**

México AEROTRON www.aerotron.com RIVIERA NAYARIT PUERTO VALLARTA
Where Mexico Comes to Life

www.opequimar.com
fuel dock • full service boatyard • brokerage • 88-ton Travelift

Be Safe

AVOID COLLISIONS



AIS WatchMate®

“A really amazing piece of gear.
I can tell it was designed by a sailor?”

John Majewski, Skiern IV

www.aiswatchmate.com

vespermarine

(858) 405-5810

Pier 32 Marina - Your Cruiser's Headquarters!

We hosted the largest contingent of Baja Ha-Ha Cruisers in San Diego in 2008!



Passing through or want to stay in beautiful San Diego forever? Our world class accommodations await you. We also have a business center to check your computer; we'll help you with faxes, copies and information.

Baja Ha-Ha Special-Have a free night on us and a pre Ha-Ha party

- 28' - 60' slips
- Deluxe shower rooms
- Spacious laundry facilities
- Exercise/workout center
- Boater's Lounge
- High speed internet
- BBQ areas

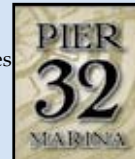

3201 Marina Way
National City CA 91950

**Call 619-477-3232
or 800-729-7547**

office@pier32marina.com

Home of Bay Yachts 619-474-5500

HONDA MARINE
IT'S ALL ABOUT POWER.

caribe
INFLATABLES

Aquapro
INFLATABLES



HONDA MARINE
IT'S ALL ABOUT POWER.

TOHATSU
outboards

Achilles

We've been THE Bay Area authority for inflatables and outboards for more than 35 years.

Call us today for quotes.

Voyager Marine

1296 State St.
P.O. Box 246, Alviso, CA 95002-0246
(408) 263-7633 • (800) 700-7633
Open Tuesday thru Saturday



Ventura Harbor Boatyard, Inc.

Located halfway between San Francisco and San Diego

Official Sponsor
2009
BAJA
HA-HA



OPEN SATURDAYS

Two Travelifts
Haul-outs to 160 Tons
Painting
Rigging
Machining
Welding
Electrical
Sandblasting
Woodwork
Chandlery
Custom
Stainless

1415 Spinnaker Drive, Ventura, CA 93001
(805) 654-1433 • www.vhby.com

Please read before submitting ad

Classy CLASSIFIEDS

Here's What To Do:

Write your ad. Indicate category. Remember price and contact info. We make final placement determination.

Count the words. Anything with a space before and after counts as one word. We will spell-check, abbreviate, edit, as necessary.

Mail your ad with check or money order, deliver to our office; **OR, for the best – and most exposure – of your classified ad...**

Submit your ad safely online with Visa, MasterCard or AmEx at: **www.latitude38.com**

Ad will be posted online within two business days, appear in the next issue of the magazine, and remain online until the following issue is released.

PERSONAL ADS

1-40 Words \$40
41-80 Words \$65
81-120 Words \$90
Photo \$30

• Personal Advertising Only •
No business or promo ads except Non-Profit, Job Op, Business Op

'Trying to Locate' Ads are for those searching for lost boats/people – not shopping – and cost **\$10 for 20 words max**

FREE Online Ads are for a private party selling a boat for less than \$1,000 – or gear totalling under \$1,000. (One per person; must list prices in ad.)

All ads will be set to fit *Latitude 38* standard • Re-Run Ads: Same price, same deadline

BUSINESS ADS

\$70 for 40 Words Max

• All promotional advertising •
1 boat per broker per issue
Logo OK, but no photos/reversals
No extra bold type • Max: 12 pt font
Artwork subject to editor approval.
Biz ads will not appear on website.

DEADLINE

is **ALWAYS** the **18th at 5 pm**

for ad to appear in the next issue.

Due to our short lead time, deadlines are very strict and include weekends & holidays.

Sorry, but...

- No ads accepted by phone
- No ads without payments
- No billing arrangements
- No verification of receipt
- We reserve the right to refuse poor quality photos or illegible ads.

Latitude 38 15 Locust Ave, Mill Valley, CA 94941 Questions? (415) 383-8200, ext 104 • class@latitude38.com

WHAT'S IN A DEADLINE? Our Classified Deadline has always been the 18th of the month, and it's still pretty much a brick wall if you want to get your ad into the magazine. But it's not so important anymore when it comes to getting exposure for your ad. With our new system, your ad gets posted to our website within a day or so of submission. Then it appears in the next issue of the magazine. So you're much better off if you submit or renew your ad early in the month. That way your ad begins to work for you immediately. There's no reason to wait for the last minute.

24 FEET & UNDER



22-FT MULL POCKET ROCKET, 1989. Hood River, OR. \$15,075. New mast, rigging, sails, 2004. All new paint 2008. Self-tailers, self-tacking hardware, instruments, trailer. \$15,075. Lots of extras. More info and pictures on website. www.gorgesat.com/rocketboat (541) 386-2037 or (541) 490-3119 gorgrocket@earthlink.net.

24-FT J24, 1979. Berkeley. \$6,500/obo. Ready to sail daysailer/club racer. Two full sets of sails. Mercury 2-stroke 4-hp. Standing rigging updated. Distinctive yellow hull. Well maintained, sailed often. Slip near BYC. Price reduced. (415) 550-8246. Email: darrenwc@gmail.com.

20-FT CAL, 1963. Berkeley Marina, O-11. \$500/as is. New bottom in Nov. 2008. Enlarged forward hatch. 5 horse Nissan 2 stroke. Topping lift. One jib, 2 mains, compass. Fiberglass over wood rudder. LED running lights. Needs upper deck paint. Sails great. Medical problems, must sell. Email: ograham@sbcglobal.net or call (510) 548-4676.

24-FT MELGES, WEST COAST. \$26,000+ Make offers. Hull numbers 15, 14 and 87, for delivery on the West Coast. Pricing starts at \$26,000 US. All are in good condition, ready to race. Fast, easy to trailer. Contact Frank. (512) 750-5735. Email: cabosportsfrank@yahoo.com.

25 TO 28 FEET

27-FT ANTRIM, 1999. Richmond YC. \$38,500. *Always Friday*, hull 15, has an excellent SF Bay racing record (National champion in 2004 and 2007, and multiple-winner of MORA in OYRA). Main features: Carbon mast, lightly used carbon sails, Nexus instruments with integrated GPS, and a trailer. Has two built-in marine batteries that are charged with a solar panel. If sold in Bay Area, I will bring new owner up to speed on A27 go-fast tricks. (925) 443-4659. Email: jwliebe@pacbell.net.

25-FT OLSON, 1987. San Diego. \$15,000. Hull number 105. Pacific Boats built. Excellent condition. All standing and running rigging replaced. Ballenger standing rigging. Vectran halyards. Dyneema control lines. Harken carbo blocks and foil. New Ullman racing dacron main and 150 Fiberglass genoa. Other sails: spinnaker, 135 genoa, 100 jib, 98 blade, delivery main. Tiller/pilot. Boomkicker. New lifelines. New Lewmar Ocean forward hatch. Engine: Johnson 4HP 2 cycle long shaft. Asking \$15,000. Email: jsruss@msn.com or call (619) 933-7630.



25-FT CATALINA, 1986. Delta. \$5,495. Poptop cabin roof, outboard, roller furling jib, sleeps 2+, daysails 6+, galley, head. Clean and ready to go. High thrust outboard also available. More pictures at website. Make us an offer! www.deltadrifter.com. (916) 777-5510 or (408) 279-4435 or email: mail@deltadrifter.com.

27-FT HUNTER, 1980. \$6,700. Beautiful 27 foot Hunter sloop, great Delta cruiser, eight opening ports, two opening hatches, wheel steering, new main and jib, six winches, lines aft, diesel, bimini, swim ladder, chain locker, teak brightwork, five berths, beautiful mahogany trim interior, VHF, inverter, holding tank, teak and holly sole, excellent cushions, alcohol stove, pressure water, two sinks, well equipped with flares, bell, life jackets, lines, etc. Great layout, excellent condition, turnkey operation. Call (925) 516-2877 or email buzg@comcast.net.

25-FT LANCER, 1978. Folsom Lake Marina. \$4,200. Includes 10hp Honda, trailer. Owner since 1984. Fresh bottom paint, shoal keel, standing room cabin w/galley, head and 4 berths. Sails (5), hull and rigging in good condition. (916) 342-2546 or email Kbell34@hotmail.com.

DINGHIES, LIFERAFTS AND ROWBOATS

9-FT WEST MARINE INFLATABLE. By Zodiac, 2003. San Francisco. \$2,300. With 6hp Mercury, high pressure bottom, pump, running lights, wood transom, five life jackets, two props. Hardly used. Fresh water only. (415) 681-7310 or email krurz9@sbcglobal.net.

14-FT LASER, 1979. Richmond YC rack #040 \$600. Price reduced. Dry hull, in good shape, no cracks in mast-step or daggerboard slot, fiberglass daggerboard and rudder. Old class sail, newer non-class sail. jsguttoff@hotmail.com. (415) 994-3500.



Yacht Repair Design / Consulting

Custom Interiors Exterior Joinery



STEVE'S MARINE WOODWORK

60 C Libertyship Way, Sausalito
jonessail@aol.com • (415) 332-2500

NOR-CAL COMPASS ADJUSTING

Magneuto™ System Exclusively
Boat Remains in Berth • Eliminates Deviation
Authorized Compass Repair • All Major Brands
Hal McCormack • Phone/Fax: (415) 892-7177

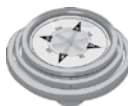

CHART SAVINGS UP TO 76% HIGH DEFINITION PRINTS • 256 INCREDIBLE SHADES!

Worldwide • Sample Chart \$5.95 • Affordable E-Chart back-ups
Bellingham Chart Printers Division, TIDES END LTD., PO Box 397L, Shaw Island, WA 98286
800-643-3900 • fax: 360-468-3939 • www.tidesend.com • sales@tidesend.com

BOAT • LETTERING

alphaboatsue@aol.com • (510) 599-1197 • www.alphaboatgraphics.com

Creative and durable lettering and artwork for your boat

26-FT LAGUNA 26S, 1984. Berkeley. \$6,500. Good condition. Very roomy, 6'2" headroom, teak cabinetry, full galley, nav station, large aft berth. Newer sails, all lines led aft. 3' draft, encapsulated lead ballast. Trailerable. Berkeley berth. Bottom in good condition. Recent underwater survey. (510) 780-6475 or email Manukeajason@yahoo.com.

26-FT MACGREGOR, 2006. Loch Lomond Marina. \$22,900. Very clean boat. Excellent conditions. Completely equipped. Blue hull, 50HP Evinrude E-Tec, shore power, second battery, GPS/VHS, bottom paint and much more. Leaving for Europe so have to sell. (650) 222-8748.

25-FT CAL 25 JENSEN, 1965. Clear Lake/Soda Bay. \$4,000. Sleeps four adults. 10 horse Johnson longshaft, furling jib, 30 gallon water tank, VHF/UHF radio, compass, depth finder. Keel draws 4' water. 1-year-old tandem axle trailer, new tires. New bottom paint and hull. (707) 489-0189.

29 TO 31 FEET



31-FT CATALINA 309, 2007. Alameda Marina. \$91,000. Catalina 309 'Boat of the Year' 31 ft x 11'6". New 11/07. Furling main, jib. Lines to cockpit. 2 enclosed cabins, 7 berths, 8 opening hatches/ports. 21 hp. 3 cyl. Yanmar, chart/cockpit tables. AC/DC fridge/freezer, LPG stove-oven, microwave, water heaters, autohelm, chart plotter, wind, tridata, electric windlass, mast VHF/TV. Spacious saloon, cockpit storage. Stern shower/ladder. Lead keel. Fully equipped sail/navigation/comfort. (510) 490-3575 or joan_robert@juno.com.

INTERNET FRAUD. Recently, we've been getting another tidal wave of reports of Internet scams, so we feel compelled to warn you once again about this unfortunate aspect of human nature. If somebody wants to buy your boat sight unseen, and suggests sending you a cashier's check for more than the asking price, trust your instincts. It is too good to be true. Usually they want you to cash the check and return the remainder to them for shipping costs. Then, much later, the bank informs you that the check was no good. We recommend that you don't even respond to the initial email inquiry. For more info on these cons, see: www.craigslist.com/about/scams.html Brave New World.

30-FT TARTAN, 1978. Alameda. \$15,000. Well maintained, very clean, classic Sparkman & Stephens design with reliable Atomic 4 engine, many extras. Dodger, furler, BBQ, new head, stainless fuel tank and new prop. (510) 864-9880 or email ejwoollett@aol.com.



29-FT RANGER, 1972. Alameda. \$11,000. Great Bay and Delta cruiser! Sleeps 5, GPS, VHF, auto pilot, chart plotter, Atomic 4 engine. Ready to go! For more info: www.wikipedia.org/wiki/ranger_29. Serious buyers please. (510) 769-9999 or email chipman.bill5@gmail.com.



31-FT CAPE GEORGE CUTTER, 1992. Port Townsend, WA. This CG is one of the finest examples of a yard-completed Cape George 31 in existence. Launched in 1992, carefully maintained, well equipped for extended cruising. Interior layout features laminated Port Orford cedar beams, trim with teak cabinets. Double berth forward, enclosed head with shower, settee-berths amidships, overhead skylight. Aft galley to starboard, nav station to port. Cockpit has two large cockpit lockers, 1 propane locker and 1 lazarette locker. New engine, radar, Trinka dinghy, running backstays, downwind pole, windlass, AGM batteries, Force 10 stove, BBQ, boom gallows, windvane, SSB, VHF, new thru-hulls/seacocks, etc. See at: www.capegeorgecutters.com/brokerage/Infinity.html. (360) 385-3412 or cgmw@olympus.net.

30-FT CAPE DORY CUTTER, 1984. Tomales Bay. \$37,500. Well maintained. Recent E80 radar, Variprop, new upholstery/cushions. A sweet sailing boat and easy to singlehand. Lots of pictures at website: <http://cd-30.blogspot.com> (click to enlarge photos). (510) 910-2099 or mbritt@eyedocs.com.

30-FT ISLANDER BAHAMA, 1981. Alameda. \$15,000. Volvo Diesel. Dodger, Harken roller furler, knotmeter, depth-finder. H/C pressurized water. Autohelm, GPS chart, stereo, new interior cushions. Well maintained and loved. Photos upon request. (510) 638-1025 or (510) 333-4342. Email: lencardoza@yahoo.com.



30-FT CAPE DORY, 1982. Morro Bay. \$33,000. Volvo MD7A, VHF radio, Garmin GPS/chartplotter, JRC radar, dodger, cockpit shade and enclosure. Bought bigger boat, need to sell. Contact via email: bobjenkizziar@sbcglobal.net. Call (559) 925-1223 or (559) 707-7344.

30-FT CAL 2-30, 1969. RYC. \$14,000. Great Bay boat, 25hp Universal diesel, Ballenger boom and spreaders, new interior cushions, autopilot, hard vang, fully battened main, 3 jibs, spin gear, inflatable/outboard. (415) 246-0324 or email coyne49@comcast.net.



30-FT CATALINA, 1990. San Francisco Marina. \$39,000. Excellent 1990 with a desirable transferable slip in the SF Marina. Dodger, new Harken furler, new standing rigging, wheel, new throttle & shift cables, new house batteries, Autohelm ST4000, Raymarine ST360 depth, new macerator pump. Just hauled and bottom paint. Slip transferable upon Harbormaster approval. (916) 803-6410 or email gkmunoz@gmail.com.

29-FT J/29, 1985. Seattle, WA. \$23,000. *Abracadabra*. Excellent race history. Completely refurbished in 2003. B&G instruments, rod rigging, faired hull, hydraulic backstay. Too many trick items to list. (253) 288-0117 or (206) 571-1676. Email: stevemil@grahamus.com.



29-FT CAL, 1970. Point Richmond. \$8,500. Very clean. Equipped with mainsail, 3 jibs and spinnaker, five winches, depth sounder and knotmeter, professionally rebuilt Atomic 4 engine, anchors, and spare folding prop. (916) 498-1610 or (916) 752-6696.

30-FT ISLANDER BAHAMA, 1982. Sausalito. \$17,000. Very clean. Roller furling jib, Volvo diesel, new port lights, standing rigging replaced in 2001. Professionally maintained. Must see and sail. Sausalito slip included with ownership. Call Jack. Email jack@modernsailing.com or call (415) 331-8250.



30-FT BABA, 1984. Newport Beach, CA. \$56,000. Price reduced! Bob Perry design. New engine (2008), rigging and chainplates (2005), mainsail (2005). Way too much to list. Please check the web page for more details and photos: www.ballreich.net/mandisa/tour/boat_specs.html. (949) 375-3564.



31-FT WYLIE, MOONSHADOW, \$18,000/obo. One of Tom Wylie's best custom-designed yachts for SF Bay and ocean racing. A winner, remains competitive today. Yanmar diesel, 9 Barient winches, stainless rod rigging, Barient backstay adjuster, Quickvang boomvang, large sail inventory, Martex prop. Sleeps 6. Hauled 10/08, new bottom paint. Excellent condition. Race ready. (415) 435-1006 or (415) 377-6688.

30-FT PEARSON 303, 1983. Corinthian Yacht Club, Tiburon. Beautiful boat in excellent condition. Sturdy, seakindly Bay cruiser. Make offer, must sacrifice! Email: michaelhillman@comcast.net or call (415) 713-3250.

32 TO 35 FEET

32-FT PEARSON, 1979. Racer/cruiser. Alameda. \$22,500 or a reasonable offer. Fast, easily singlehanded sloop. Featured in August 2007 *Practical Sailor*. 1250 hours on original M-15 Universal Diesel. Gear (vintage '95): Autopilot, digital depth finder & gauge, Harken furler, Navtek backstay adjuster, Hall Spars Quikvang, Furuno radar, 25-watt marine radio. New: 19-gallon aluminum fuel tank and electric fuel pump (2002), 2 batteries (2006). Documentation: all original manuals, '95 survey, maintenance, diving, haul records since my '95 purchase. (510) 525-2754

WOODRUM MARINE

Specializing in custom interior cabinetry, tables, cabinets, countertops, cabinsoles. For power or sail.

CARPENTRY
Mobile cabinet shop
Contact Lon Woodrum at:
415-420-5970
www.woodrummarine.com

VOLPAR, Inc.

(408) 986-0848 • (800) 258-4545
Parts • Service • Penta Only
10am-7pm PST every day including Sat-Sun
email: Volpar@Volpar.com

VOLVO
PENTA



EAST BAY SAIL & COVER CLEANING

mildew, rust, grunge, sail repair

(510) 523-9011



MARINE SURVEYS by Captain Alan Hugenot

Naval Architect • Yacht Delivery Skipper

Accredited Marine Surveyor (SAMS)
Bay or Delta • No Travel Charges • MC / VISA / AmEx
alan@captainhugenot.com • **(415) 531-6172**

Custom Canvas & Interiors



The Gianola Family has been designing and fabricating custom canvas and interiors since 1969. Gianola Canvas Products offers you the best in quality, more choices, and personal service.



265-B Gate 5 Road
Sausalito, CA 94965
(415) 332-3339
www.gianolacanvas.com



**Society of Accredited
Marine Surveyors®**

Serving Northern California

Jesse Brody, AMS®

415.342.0757

jesse@baymarinesurvey.com

Tom List, AMS®

415.332.5478

listmarine@yahoo.com

Jack Mackinnon, AMS®/SMS

510.276.4351

surveyjack@aol.com

Francoise Ramsay, AMS®

415.497.7409

framsay@comcast.net

Randell Sharpe, AMS®

877.337.0706

rsharpe@sharpesurveying.com

Susan Tupper, SA

916-216-4374

susantupper@gmail.com

Rick Whiting, SA

415.740.2924

captain_rick@sbcglobal.net



35-FYORKTOWN, 1976. St. John, U.S. Virgin Islands. \$45,000. Just completed 4-year circumnavigation. Baja Ha-Ha 2005 and Puddle Jump 2006 Vet. Many upgrades and ready to go. Why get beat up sailing down the Caribbean, buy one that is already there! Find photos and equipment listing at: <http://sandpiper38.blogspot.com>. Email sandpiper_38@hotmail.com or call (340) 514-0778.

34-FY SAN JUAN, 1984. \$39,000. Fast comfortable, blue water cruiser, excellent condition. 6' headroom, galley, sleeps six, rod rigging. Roller furling headsail, 150% genoa, main, working jib, in good condition. 3GMD Yanmar, Achilles dinghy, large bimini. Price reduced. (510) 420-8956 or email nino@access-print.com.



35-FY 1D35, 1999. Richmond. \$79,500. Two time Rolex 1D35 Big Boat Winner, *Diablita* is in turn key condition. Always drysailed, competitive inventory and practice sails, with trailer. This one design thoroughbred is only 6500lbs, and is ready for anything. Professionally maintained by KKMI. (510) 237-7600 or (510) 289-6422 or email gboell@innovaflavors.com.



33-FY DUTCH STEEL-VANDERVELS. San Francisco. \$27,000. Ready to cruise. Survey (+hull) available. Rare aft cabin (separate entrance). New: Boom, head+macerator+holding tank, alternator, inverter, topside paint, varnish, GPS, stereo, netting, fridge. Autopilot, reliable Volvo 24-hp, 3 anchors+all chain. Full specs/pics: www.elsewhere2.webs.com. Email steelboat2009@hotmail.com or call (415) 509-1277.



Fred Andersen Boat & Woodworks

**Repair,
Restoration &
New Construction
(510) 522-2705**

SMALL AD, SMALL PRICES • RIGGING ONLY

Standing and running rigging, life lines, furling gear, winches, line, windlasses, travelers, wire and terminals, blocks, vang, and much more.

~ ~ ~ Problem solving and discount mail order are our specialties ~ ~ ~

www.riggingonly.com • (508) 992-0434 • email: sail@riggingonly.com

34-FY GEMINI 105MC, 2005. Redwood City, CA. \$160,000. Shipped August 2005. Screecher, hammock seat, microwave, Furuno NavNet GPS/radar/target tracking/fishfinder, Prosigne 2000W inverter/charger, NewMar battery monitor, 200AH gel batteries, AB RIB/8HP Honda 4-stroke, Fortress F28, Honda EU2000 generator, new upholstery and new bottom June 2009. Much more! (650) 380-3343 or email brian.j.gibbons@gmail.com.



35-FY J/109, 2004. Sausalito. \$185,000. Fast, fun, mint condition racer/cruiser singlehand or with crew. 1st 2008 J/109 Division, 1st 2009 J-Fest Division, 3rd PHRF (72 rating). Quantum Kevlar racing and Dacron cruising sails (2 mains, 2 jibs), 2 asymmetric spinnakers, new rigging, Spectra lines. B&G instruments, VHF radio, GPS, Yanmar diesel, 29 hp, excellent condition. Doubles as performance cruiser with roller furling, all rigging led aft, sleeps 6+ with full galley, head, shower, hot/cold water, fridge. Ready to race one-design, Pac Cup, PHRF or cruise oceans SF Bay and Delta in comfort, style and performance. Must sell. (415) 717-3664 or email ahoys@earthlink.net.

33-FY STEEL SAIL, 2006. Lowrie Harbor, San Rafael. \$62,000. 33' custom steel sloop. Round bottom, 28 hp Beta diesel, Hogan full batten main, Monitor vane, SS galley, Raytheon radar/GPS. Berth #101. Email derwinski@pacific.net or call (707) 895-2813.



35-FY YORKTOWN, 1974. Emeryville Yacht Harbor. \$29,000. Proven blue water cruiser priced to move! Over 10k miles under the keel. Ready to cruise! One family has owned her since construction. See website for specs, photos and details: www.maryanntwo.com. (408) 202-4944 or email: mortensontyler@yahoo.com.

35-FY J/35, 1986. Vallejo. \$42,900. Nice condition. The boat has an excellent racing record and a great sail inventory. It has much new gear including some cruising inventory. Email okline@wildblue.net or call (530) 622-8761.



34-FT PEARSON, 1984. Vallejo. \$39,000. Harken furler. 125, 110, 90 heads'ls. Hydraulic backstay. Rigid vang. Nexus 3000 instr. Autopilot, GPS, radar detector. Diesel 1,200 hrs. Free sailing lessons. Negotiable extras: Life raft, 406 EPIRB, folding bikes, more. (707) 427-2291, (707) 479-3434 or frankgmena@hotmail.com.



35-FT HALLBERG-RASSY, 1972. Moss Landing, CA. \$55,000. This is a nice center-cockpit bluewater cruiser. 30k in the last few years. Rebuilt Volvo MD30A. New Ullman sails with Furlex on jib. New rigging. Comnav autopilot, Raymarine plotter, radar, Interphase Outlook and more. Email: olinjordan@yahoo.com or call (831) 595-2467.



35-FT ERICSON 35 II, 1971. Newport, OR. \$30,000. Excellent condition. Very well maintained. New Yanmar engine <100 hrs. Radar, windvane, roller furling, etc. Great boat. Slip available. (541) 990-9613 or email sj211509@hotmail.com.

34-FT SHADOW, 1984. Ventura. \$46,000. Denis Ganley design - Steel. Excellent condition and loaded with cruising gear. Ready for high seas anytime. Kuari wood interior. Pictures, specifications and last survey on request. (805) 205-6093 or email apburkot@yahoo.com.



32-FT BRISTOL, 1978. Ixtapa, MX. \$19,000/obo. Early retirement, laid-off? Maybe it's time to get away. Our 2004 Baja Ha-Ha vet is waiting for you in Ixtapa. Fully equipped for cruising, nothing to buy. Give her a coat of bottom paint and wait for the fleet in Zihuatanejo. Later go back up to the Gulf for the best sailing in Mexico. 32' is the ideal size for the Sea of Cortez. Tuck in the little bays. Anchor in 10' of water. More details and list of equipment on the website: www.eblw.com/contepartiro/contepartiro.html. Make me an offer I can't refuse. (510) 367-5621 or email janne8@eblw.com.



32-FT COLUMBIA 5.5 METER, 1960. SF Marina. \$7,000. Located in East Harbor, SF Marina. Slip transferrable upon harbor-master approval. Has current sails (main, jib, and spinnaker), refinished/repainted interior, new rigging, new cleats, new adjustments, new bottom (super fair carbon anti-foul), new lines, remotely adjustable jib leads, topsides polished, wire hoisting slings, and a new cover. (415) 244-5422 or email cmtozzi@sbcglobal.net.



35-FT HALLBERG-RASSY RASMUS. (sloop), 1974. Berkeley Marina. \$25,000. Classic Swedish cruiser. Great teak and mahogany woodwork. Solid wiring and electronics. Needs new engine, cushions and bottom paint job. Spacious main, aft and fore cabins. More pics available. As-is condition. Buyer to do survey. Call (206) 718-2350 or kristindizon@comcast.net.

35-FT TRIDENT WARRIOR, 1973. Moss Landing. \$49,000. Ready for a bluewater cruiser upgrade? This boat can take you anywhere in the world, and at a price you can afford. Will consider partial trade - coastal cruiser. Too many upgrades to list. Email: rjwestbay@yahoo.com or call (559) 303-5997.

36 TO 39 FEET



38-FT KETTENBURG 38, 1956. Berkeley, Wilmington. "Nice boat!", "Beautiful boat!", "Gorgeous boat!" heard many times from other boaters during every sail. Enjoy character, admiration, and fantastic sailing while sustaining the heritage. Details at: www.sailk38.com. (916) 847-9064 or email steve@paradigmpilgrim.com.



37-FT ENDEAVOUR, 1981. Wilmington, CA. \$45,000. Excellent liveaboard with beautiful teak interior. Private owner's cabin with double berth, huge salon, hanging lockers and drawers galore. 6'4" headroom, new upholstery, canvas and cosmetics in recent years. Easy to sail. Email: sailfast6@verizon.net or call (562) 706-4334.

36-FT ISLANDER FREEPORT, 1979. San Pedro. \$50,000. Plan B model with forward head in good condition. Cape Horn self steering, dinghy davits, dependable Perkins engine. Outside wood being refinished now. Painting to start next. Buy now or pay more later when more work is done. Email gadams4292@yahoo.com or call (530) 721-1305.

36-FT JEANNEAU, 1997. \$89,000. Price reduced. Very well maintained. Electric anchor windlass, dodger, refrigerator/freezer, GPS, chartplotter, autopilot, CD player, VHF, B&G instruments, depth/knot/wind, Interphase with 2-hp Johnson. For info call Brian (209) 722-2068. To view call Roy (510) 523-4081 or email coolswick@aol.com.

36-FT PEARSON, 1985. South Beach Harbor, SF. \$67,500. A great Bay boat with deep fin keel. Beautiful, comfortable and excellent sailing boat. Original Yanmar has less than 400 hrs. Interior is near perfect condition. Roller furler on jib, Dutchman on main and all lines led aft makes for easy singlehanding. Have original bill of sale and owner's manual! Will consider partnership with right party. This is a great boat in wonderful condition. (925) 286-8738 or Bobgthomas@earthlink.net.

36-FT SABRE, 1998. Berkeley. \$155,000. Professionally maintained sloop. Shallow draft wing keel ideal for cruising. Blue hull and topsides painted 12/06. Standing rigging replaced 2/07. New autopilot 5/07. New mainsail 7/08. Furling jib and lightly used asymmetrical spinnaker. (925) 766-2205 or email dan@deltaxcavating.net.

39-FT CAL, 1978. Alameda. \$65,000. 50hp Yanmar repower 300hrs. C-80 chart plotter/radar/fishfinder, Profurl w/100% & 150 jibs. Full dodger, Maxwell 2500 windlass. This boat is very clean. For full details: www.ideasinmotion.com/cal39. Email borelimg@earthlink.net or call (510) 864-0237.



39-FT YORKTOWN SLOOP, 1977. Napa River. \$18,500/obo. Tall rig, skeg keel, Westerbeke diesel, newly overhauled transmission, CNG stove, complete galley, solar panel. Two staterooms, one marine head, very roomy, sleeps 7. Many new items on recent overhaul. Sturdy and sound, fun coastal cruiser. Last appraisal available. Email atplgd@aol.com.

36-FT CAL-CRUISEING, 1969. La Paz, Mexico. \$29,500. Perkins 4-107, 7 sails, MaxProp, AMS autopilot, Monitor windvane, Harken furling system, 8 self-tailing Barients, Navtec backstay adjuster, Destroyer wheel, stout rigging, heavy tackle, Lofrans Tigress, Ratheon radar, SSB, EPIRB, C.A.R.D., Zodiac liferaft, Siemens solar panels, energy monitor, AirMarine windgen, large tankage, refrigerator-freezer, Force-10 stove, fresh/salt-water power wash, 11' Hypalon inflatable, 2 outboards. Extra parts, service manuals, etc. Affordable turn-key cruiser. Email swdnwr@gmail.com. (707) 839-0120 is only good to mid-October, then we are in Mexico.

39-FT YORKTOWN, 1980. Marina Bay, Richmond. \$27,500. Full size bed in aft cabin, V-berth, CNG gas stove/oven, microwave, refrigerator, freezer, ice maker, TV, DVD, VHF, radar, GPS, depthfinder, 50hp diesel, electric windlass, electric head, separate shower. Great liveaboard. (209) 743-6275 or vik@inreach.com.



boat bottom scrubbing & more . . .

415 331 7215 william@gotzinc.com

For the best - and most exposure - of your classified ad...
submit your ad safely online at: www.latitude38.com.

Classy Idea!

Your ad will be posted online within two business days, appear in the next issue of the magazine, and remain online until the following issue is released.



STARBOARD YACHT DELIVERIES

Over 50,000 sea miles • Pacific, Caribbean, Atlantic
USCG Master 100 GT STCW • Power & Sail

Rick Whiting • (415) 740-2924 • captain_rick@sbcglobal.net

VOLVO PENTA

Specialist Dealer Since 1980

ESKELUND MARINE • (510) 523-7670

1913 Clement Ave • Alameda Marina • Bldg 13 at Pier 2



**STRONG, SAFE, SIMPLE
MAST STEPS**

CLIMB THE MAST
EMERYVILLE, CA 94608
(301) 706-3662
WWW.CLIMBTHEMAST.COM

**STAINLESS STEEL
CHAIN**

Custom lengths
in link sizes from 5/32" to 1"
in Proof Coil and BBB Chain

*Strength, Quality
and Dependability...
plus a Lifetime Warranty!*

**Stainless Steel Marine Hardware,
Rigging & Fittings at Reasonable Prices.**

See our complete catalog and order on the Web:

www.BOSUNSUPPLIES.COM

Or call toll-free for catalog and to order
(888) 433-3484



**VOLVO
PENTA**

ENGINES • PARTS • SERVICE

*We Ship
Anywhere*

1-800-326-5135

(415) 453-1001
FAX: (415) 453-8460
www.helmutsmarine.com
619 Canal Street
San Rafael, CA 94901

HELMUT'S

MARINE SERVICE INC

AUTHORIZED POWER CENTER

**Marine Diesel Specialists
AT YOUR SLIP!**



30 years experience • Universal/Westerbeke dealers
Repairs/Tune-ups all models • Engine Surveys, Instruction

BAY MARINE DIESEL **510-435-8870**

baymarinediesel@comcast.net



38-FT MORGAN CC, 1993. San Diego, CA. \$75,000. Waterfront living at its best. There is no other option out there that allows oceanfront property at this type of price in San Diego. Morgan is an excellent sailboat and there are 5 currently for sale across the country. The prices range from 93k to 130k. This boat was listed for 110k and is now listed for 75k, well below the market rate. Take advantage of this for sale by owner/no broker offer today. Additionally this boat is located at Humphrey's by the Bay, which has live concerts from May-October for your viewing, listening and entertainment pleasure, check www.humphreysconcerts.com. (619) 243-6269 or jdarrochdesign@yahoo.com.

39-FT FREYA, 1977. Antioch City Marina, CA. \$49,500. Serious, quick passage maker, priced for buyer's market. Hull #4 from Gannon Yachts, 4 used sails, one new, autopilots, Aries, grounded and wired for SSB, depthsounder, GPS. Contact owner for details and history: www.ablboats.com/details.php?id=85646. Email: crowellam@hotmail.com or call (925) 522-1353.

36-FT BENETEAU 361, 2002. SF Marina West Basin. \$118,000. Bristol, loaded, custom, all electronics, recent haul-out and bottom paint + coveted SF Marina berth. Will consider lease or non-equity partnership. Call (415) 771-0741 or email Bob@TandlerSF.com.

37-FT CREALOCK, 1980. Monterey. \$65,000. Cutter. Ballanger tabernacled mast. New Yanmar w/saildrive, radar, GPS, easy access to all systems, 70gal diesel, 3 watertight bulkheads. Not in yacht condition, needs finish work. Great little sailing ship. Price firm. Email: ddatpbio@gmail.com.

37-FT HUNTER LEGEND, 1989. Napa Valley. \$55,000. Perfect Bay boat. Comfortable, easy to handle! Great deck space, aft cabin, Yanmar 30hp diesel w/658 hours. Draft 4'9". Doyle stack pack on main and furling jib. Please email for pics: mmoonoggie@gmail.com or call (208) 880-6135.

39-FT COLUMBIA, 1971. West Palm Beach, FL. \$30,000. Deep draft 7', tall rig, wind gen. Westerbeke, propane, (AC, 6.5gen. needs work). Dual diesel tanks, dual battery bank, Anderson 46 winches, brand new Sta-Lok rigging and genny, extra sails including storm, new head, great storage, 7' headroom, very roomy for liveaboard. (954) 325-0118.



36-FT CATALINA MKII, 2001. Sausalito Yacht Harbor. \$100,000/obo. Fresh-water beauty. Moved from Tahoe this June. 185 hours on Universal 35hp diesel, Raytheon electronic package, poleless Pineapple cruising spinnaker, blue cockpit dodger, 10 CD stereo system w/external speakers, propane external grill (never used), completely furnished galley including microwave oven, large refrigerated ice box and dry food locker. (650) 400-6898 or email dfoley@ewingfoley.com.

40 TO 50 FEET

42-FT TAYANA VANCOUVER, CC, 1987. San Carlos, Mexico. \$149,900. Beautifully maintained, proven safe passagemaker, upgraded comfortable interior, island master bed, electric toilet, separate shower, watermaker, MaxProp, 3 furling sails, solar panels, wind generator, wind vane, upgrades and spares. See more at: <http://pacificcruising.blogspot.com>. (520) 803-0240 or herronsflight@yahoo.com.au.

40-FT HUNTER LEGEND, 1986. La Paz, MX. \$76,000/obo. Multiple upgrades since 2006 include: radar, chart plotter, SSB, refrigeration, propane conversion, StackPack, solar, and more. Cruising Mexico past two seasons and ready to go again. Contact for details. (530) 957-2810 or email gregondetente@gmail.com.



48-FT CELESTIAL, 1986. Spacious, well-built center-cockpit ketch. Fantastic boat. Excellent condition. Many special features. Fully cruise ready. Great value. Beginning January, visit *Reba* in Puerto Vallarta. See *Reba* overview, details and contact info at: www.celestial48.com. (775) 832-7979.

41-FT MORGAN CLASSIC MODEL, 1991. San Carlos, Mexico. \$98,000. Primo condition. Equipped and ready to cruise. Center cockpit, great liveaboard, must see to appreciate roominess. Recent survey. For equipment list and current photos: <http://sailboatvagari.blogspot.com>. Email: stanstrebbig@gmail.com or call (520) 825-7551.

COMPLETE MARINE WOODWORK

Design / Restoration • Expert European Craftsmanship • Interior / Exterior
Repairs / Maintenance • Marine Windows & Frame Replacement
Wood & Dry Rot Repairs • Varnish Work • Marine Painting

References Available • Reasonable Rates • Call (415) 331-6718

Need Crew? Latitude 38 Crew List A Boat to Crew on?

Visit our website and sign up as Skipper or Crew • It's Free
Find out about our next Crew Party: Wed. Sept. 9 at Encinal Yacht Club
More info: www.latitude38.com/crewlist/Crew.html or call (415) 383-8200



46-FT KELLY-PETERSON, 1985. Marina del Rey, CA. \$197,000. *Reprise* was extensively refitted in 2005-2006. Upgrades include re-powering with Yanmar 125-hp turbo diesel, revision of the electrical and charging systems, new autopilot, chart-plotter, SSB, refrigeration, upholstery, canvas, liferaft, Tides Strong Mainsail track, cruising spinnaker. New last year Ullman mainsail StackPack with integral lazyjacks. The interior hand-fitted teak joinery is in excellent condition. There are 2 staterooms and 2 full heads. The headliner was completely replaced in 2000 and appears new. The KP 46 is a proven bluewater cruiser, yet sails beautifully in light air. *Reprise* is ready to cruise. (310) 871-5260 or chasfu2@gmail.com.



41-FT FORMOSA KETCH, 1978. Rio Dulce, Guatemala. \$52,500. Classy boat with excellent cruising inventory. Fiberglass hull, hardwood and fiberglass topsides, aluminum masts. Perkins 4-108 rebuilt 2005. Radar, wind and solar power, hydraulic steering, new fridge 2008. Two single, two double berths. Much more. Moored in fresh water, easy sail to Belize. www.tombuttsmontana.com/dragonlady.html. Email: windseeker10@rocketmail.com or call (406) 431-9582.



41-FT NEWPORT MK II C/C, 1981. Napa. \$39,000. Engine rebuilt-10 hrs. Bottom paint '09. Long distance cruiser or liveaboard. (530) 908-8555 or email jenedix@yahoo.com.



45-FT BENETEAU 45F5, 1991. Ventura, CA. \$125,000. Racer/cruiser, PHRF-63, with 3 cabins, 2 heads, beautiful wood interior. Price lowered for quick sale. Recent upgrades: New MaxProp 2008, fridge, inverter/charger, anchor, windlass. Email: rkrause@rjk-law.com. Call (559) 696-9653 or (559) 261-9295.

42-FT CATALINA, 1994. Marina Nuevo Vallarta, Nayarit, Mexico. \$118,000. Two-cabin layout. Excellent condition. Cruise ready in Nuevo Vallarta, Mexico. Too many extras to list. Call for more information. (530) 318-4096 or (530) 554-4512. Email: tomanddianemiller@yahoo.com.

45-FT EXPLORER, 1978. San Rafael, CA. \$109,000. Beautiful, lovingly maintained, center cockpit sloop/cutter. Constant upgrades past 15 years. Good performer, bright interior with 2 staterooms/heads. Yanmar 62 hp, LPU, radar. Haul and survey 2008. (415) 265-4418 or email: david@winchmate.com.



48-FT J/145, 2001. Santa Barbara, CA. \$465,000. Carbon-fiber cruiser/racer. High performance boat that's fast and easy to handle. Comfortable cockpit with dodger, roller furling, retractable bowsprit. Elegant main cabin in varnished cherry and leather. B&G electronics, oversized winches, autopilot. Lighter and better than Swan. Call (805) 896-0173 or email carolyn@goodmanagementsb.com.



40-FT PETERSON TWO-TONNER, 1980. San Diego, CA. \$58,000/obo. This performance racer/cruiser sailed from San Diego to France in 2005 where she was totally refit: new Yanmar engine, hull/deck/mast paint job, bottom fairing, new head, rigging verification, new MaxProp, etc. After several regattas in France, and months cruising the Caribbean, she was sailed back to San Diego where upgrades continued: New refrigeration, new water heater, bottom job/deck paint, March 2009. Race in SoCal (PHRF 69) then cruise the islands in style. (619) 467-6369 or email bruno.bomati@gmail.com.

45-FT WAUQUIEZ CENTURION, 1992. \$155,000. High quality, fast, performance world cruiser. Safely go anywhere. Passages with 200 mpd made good. We cruised the Caribbean and Pacific and now she must be sold. Solid FRP hull, masthead sloop, removable cutter stay, Harken furling, full-batten main, Windpilot servo-vane, swimstep transom, Lofrans electric windlass, dual-refrigeration, new Balmar alternator/digital charger, 1000w inverter, Icom SSB and VHF, Furuno radar, lots more. Photo and inventory available. Discount for quick closing. For more info: tunes@aloha.net or call (808) 826-6050.



44-FT TASHIBA 40, 1987. Honolulu. \$229,000. Exceptional cruising yacht with numerous upgrades. Extremely well maintained and ready to cruise anywhere in comfort and safety. Huge storage, custom hard dodger and bimini, solar, wind gen. Visit our website for all the details: www.amazing-grace-sails.com. Email: richard@amazing-grace-sails.com or call (808) 721-4666.



47-FT PERRY, 1979. Channel Islands Harbor, Oxnard, CA. \$179,000. Center-cockpit cruising cutter. Cruise ready, just add your personals and provisions! Bob Perry pedigree, bullet-proof construction, professional captain/owner updates. Reduced from \$199,000. (619) 818-5878 or email richvanorsdal@gmail.com.



41-FT MORGAN CLASSIC, 1988. Marina Del Rey, CA. \$99,000. Center cockpit. Yanmar diesel engine (300 hrs). Boat has been updated/upgraded in 2008 & 2009 inside and out. (818) 892-0006 or email: kjeby@adelphia.net.

45-FT HARDIN VOYAGER, 1978. Long Beach. \$55,500. Classic Bill Hardin sloop-rigged ocean cruiser back from cruise to Panama, Caribbean and East Coast. Waiting for her next adventure. All sails roller furling. Fiberglass, Isuzu C240, 200 gals fuel/water. (480) 215-8224 or email pilot435@hotmail.com.



50-FT HUDSON FORCE 50. Offshore Ketch, 1979. Blaine, WA. \$169,000. Great Liveaboard. 5 staterooms, 2 heads, 80hp diesel, 200g water, watermaker, autopilot, SSB Ham, liferaft, dinghy. See more at: <http://mysite.verizon.net/resx8t9g>. (360) 371-0904 or svketch50@verizon.net.



47-FT CUSTOM FIBERGLASS CUTTER, 2004. Coos Bay, OR. \$499,000. Blue water high latitude cruising sailboat, two helms, one enclosed, sleeps six, premium equipment, electronics, 85HP diesel, 4.2KW generator, workshop, 200+ fuel and water, refrigeration, washing machine, insulated. Reduced. Pictures: www.hyssop.com/boat. Call (541) 888-5688.



48-FT HALLBERG-RASSY, 2010. 1/2 price. New HR 48 for 1/2 price. Buyer looking for 1/2 ownership partner for spring 2010 delivery. Plan is to move the boat between various global cruising destinations. Email: dave_melin@hotmail.com.

42-FT CATALINA, 1990. South Beach Harbor, San Francisco, CA. \$112,000. Great condition. New dodger, radar, dinghy, chartplotter, autopilot, etc. Extensive upgrades. Full specs available: <http://www.leluya.blogspot.com>. Call Thomas (650) 298-9043.

August Enterprises
Marine Surveying and Consulting

Serving the Bay Area since 1995

510-889-8850

THIS COULD BE YOU...

Let the Classy Classified business ads work for you.

Submit online at:

www.latitude38.com

N.E. MARINE TITLE

Coast Guard documentation • Title/lien searches • Transfers • Mortgage filing • Escrow services

Local closing facility for brokers or private transactions

30 years experience of doing it right the first time

1150 Ballena Blvd, Alameda, CA • (510) 521-4925



PROFESSIONAL DELIVERY CAPTAINS

San Diego based, USCG Master 100 GT. Sail and power. ASA-certified instructional deliveries. Panama Canal and Hawaii crossing experienced.

(619) 913-7834 • davidhbrotherton@yahoo.com

COAST MARINE

& INDUSTRIAL SUPPLY INC.

398 Jefferson St. San Francisco - On the Wharf.

Call **Bruce Becker** or **Clark Atkinson**
(415) 673-1923 (415) 516-4860

800-433-8050
Fax (415) 673-1927



LIFE RAFT Sales & Service



U.S.C.G. Approved Testing Facility

- ★ U.S.C.G. life raft facility for Solas commercial yacht and fisherman rafts
- ★ COMAR DEBARKATION LADDERS
- ★ COMAR PILOT LADDERS
- ★ COMAR WORK LADDERS
- ★ All U.S.C.G. approved

GUINNESS WORLD RECORD "World's longest tested ladder 320ft."

Major Distributor for:

Pains Wessex Safety Systems

STEARNS



IN SAN DIEGO CALL OCEANS WEST 619 544-1900



48-FT CHAPELLE-DESIGNED. gaff-rigged wooden schooner, 1979. Sausalito. \$55,000. Laid in Marshall, planked in San Rafael and launched in 1979, *Henry Rusk* is a local celebrity. Pleasure to sail. New canvas cover, deck prisms, prop. Recently hauled out at Spaulding. Currently berthed in Pelican Harbor. 3rd owner. Email: zserber@gmail.com.

42-FT BENETEAU, 2003. Brickyard Cove. \$165,000. Cruise ready, with watermaker, solar with large house bank, upgraded windlass, and conventional sail w/Stack-Pack. This is a well-crafted French-built boat. (510) 847-9854.



46-FT PETERSON FORMOSA, 1979. Blaine, WA, N of Seattle. \$145,000. We just got back from a four-year cruise through the South Pacific and this was one of the best boats out there. She is fast (Peterson) and comfortable (34,000 lbs.) Full inventory of great shape sails, electronics and the motor is better than wonderful. Only .57 gals per hour motor sailing. This boat is clean, very clean and comfortable. She is ready to go around the world! Read more at our web page: www.libertydaze.com. (360) 510-7885 or email carlnichols5@hotmail.com.

45-FT ROBERTS MAURITIUS, 1985. Alameda. \$35,000. 7 sails including storm trysail & drifter. Hydraulic steering. Solidly built, 1/4" steel below gunwales. John Deere 67HP diesel, 400gals diesel, 150gals water. Radar, Dickenson stove, Avon 6 person liferaft. Mexico veteran and long term liveaboard, solid condition, needs interior and running rigging rebuild, minor repairs. Owner going overseas, wishes to find good home for great vessel that generated many fond memories. Email: steve_horne@solfocus.com or call (650) 455-1985.

44-FT BENETEAU 445, 1993. St. Thomas, US Virgin Islands. \$129,000. Cruising ready performance cruiser/live aboard located in the Virgin Islands. Watermaker, wind generator, solar, davits, AGM batteries, newer engine, navigation electronics, dinghy. <http://ansano.com/4sale>. Email: gil@ansano.com or call (340) 344-6262.

46-FT CAL 2-46, 1981. San Rafael. \$89,500. Baja Ha-Ha '08 vet. It can go again, but I can't. Must sell. 2 complete staterooms slps/5. 40 gal/day watermaker. Touchscreen GPS/radar, 272gal diesel, 200gal water. Dutchman main. Roller jib. Excellent condition. (415) 299-1087 or email millerpi@comcast.net.

51 FEET & OVER



56-FT FORMOSA CC KETCH, 1983. Alameda \$169,000. Beautiful classic lines designed by Bill Garden. This is the ultimate bluewater cruiser or liveaboard with bright raised center salon, 16-ft beam and 1-inch solid fiberglass hull, breathtaking carved teak interior, aft wrap-around master cabin with queen bed and vanity, charming private forward cabin with vanity and settee. 2 heads, showers and electric flush, 120-hp Ford Lehman diesel, dinghy, davits. 200 gal fuel and water. www.halfmoonsail.com. Email: gghaibeh@yahoo.com or call (650) 208-9887.



51-FT FORMOSA KETCH, 1981. Santa Cruz \$97,500 Price reduced. Documented. 3 br, 2 bath home; adventure included. Loving care by 2nd owner for 24 years. Sitka spruce spars, stainless steel crow's nest. Roller furling main (boomless), staysail. Maroon covers. Teak interior, varnished throughout. Benmar autopilot, radar, VHF, 80-hp Ford Lehman diesel, diesel heater, new propane range, propane water heater, coldplate freezer/fridge. 220gal. fuel, 220gal. water. 3 staterooms, 2 heads. Set up to singlehand. (650) 326-1430 or email ewhollandjr@aimg.com.

MULTIHULLS

64-FT KANTOLA, 2000. Marshall Islands. \$150,000. Comfortable, world-cruising trimaran. All cruising gear. Two staterooms, two heads, two bunks forward, two bunks aft. Needs mast and headsail. Moored in the Marshall Islands. Contact for inquiries or pictures. (692) 455-0158 or email swindswept@hotmail.com.

OFFSHORE PASSAGEMAKING INSTRUCTION IN THE SOUTH PACIFIC

John & Amanda Neal are dedicated to providing hands-on, documented instruction aboard their Hallberg-Rassy 46 *Mahina Tiare III*, drawing on their combined 502,000 miles and 66 years of experience.

www.mahina.com • (360) 378-6131

Going Somewhere? Mexico • Caribbean • South Pacific

Stop by our office and take a bundle of *Latitude 38* along with you.

We promise you'll be a hero for sharing them with other cruisers!

Latitude 38 • 15 Locust Ave • Mill Valley, CA • (415) 383-8200 • Open M-F 9-5

"YOUR DESTINATION FOR A FULL SERVICE MARINA"

800 SLIPS 20-60 FT

Clipper Yacht Harbor

Sausalito, Ca

BRAND NEW CONCRETE DOCKS!

- Dry Storage Available
- Fuel Dock
- Salty's Bait & Tackle
- Sport Fishing
- Restaurant
- West Marine
- Launch Ramp
- Pump Out
- Laundry Facility
- Private Restrooms and Showers
- Anderson's Boat Yard
- Guest Slips Available

310 Harbor Drive, Sausalito, CA 94965
(415) 332-3500 • www.clipperyacht.com

TIRED OF HAND STEERING? GET THE CPT—THE RELIABLE, POWERFUL WHEEL PILOT

- Dependable ♦ Built for Immersion
- Affordable ♦ Easy Owner Installation
- Quiet ♦ Low Power Consumption

The Delivery Skipper's Favorite

**CPT
AUTOPILOT**

831-687-0541

See it in Action!

www.cptautopilot.com





42-FT CROSS, 1982. Morro Bay. \$85,000. Trimaran ketch with beautiful mahogany and white laminate interior, yard built and loaded with gear. Perkins 4-108, MaxProp. Hawaii vet for cruising or live aboard. (805) 541-4417 or (805) 704-8613 gabarker@sbcglobal.net.



40-FT SEARUNNER, 1978. Blaine, WA. \$80,000. Among best in class. Well designed, constructed, maintained, equipped. Veteran of five-year cruise 2001-2006. Refit and survey 2007. Sleeps six, 15 sails, 30hp diesel, radar, autopilot, windvane, watermaker, 2 sailing dinghies, SSB radio, solar panels, wind gen, life raft, new paint. Awesome cruising boat. See: www.searunner40seafire.wordpress.com. (360) 756-5004 or svseafire@yahoo.com.



38-FT WHARRAM CATAMARAN, \$4,000. Aluminum mast, rigging, sails, winches, oven, 9.9 Johnson high-thrust outboard, trailer. 28' Piver tri, 2 masts, diesel, rigging, sails, winches, stove, trailer - \$2,500. Both boats need work. 1980 Step van converted to self-contained RV, generator - \$2,500. Two air-cooled Dietz diesel motors - \$1,500 for both. Enclosed trailer - \$500. Trade for Toyota Tacoma 4x4 motorcycle. (650) 207-4044.

47-FT CATANA, 2001. Puerto Vallarta. \$699,000. 472 Catana Caligo 2001, already in paradise - PV. Price reduced on this fast, luxurious, easily sailed catamaran. One hull for owners, other hull pampers guests. Full amenities, see on www.Yachtworld.com or contact owner. *S/V Moon and Stars*: cat47moon@yahoo.com. May consider real estate trade.



31-FT CORSAIR F-31UC TRIMARAN, 2007. San Diego. \$129,000. New ultimate cruiser purchased in 2007. Spec'd out for long range cruising, loaded with factory options and additional cruising gear; unfortunately, she was never sailed - ever! Offering 'No qual' financing. Details available to serious sailors. (619) 319-0136.



55-FT CATANA 531, NEWPORT BEACH. \$549,000. Cruise the world in comfort, speed and safety. Excellent condition, many spares, sprit, 2004 Yanmars with sd40s, 8.5kw, 55-gph watermaker, stall shower, 5 electric winches, good sail inventory, many upgrades. 3 autopilots, SSB, radar, Inmarsat mini-M, Micro-Commander controls, 12' Caribe with 25 hp, solar array, Profurl electric jib furler, computer with world charts, new Sealand electric heads, inverter, much much more. High quality. Prime Newport Beach mooring available. (949) 295-4116, (949) 675-0617 or jerrywoods37@hotmail.com.



48-FT CROWTHER CATAMARAN, 1991. \$279,000. Java, Cutter-rigged, built in Australia 1991. Proven bluewater cruiser built for speed under sail. Sleeps 8 comfortably. New paint top to bottom. New mast, boom, oversized rigging 2005. Equipped for the tropics around the world with large awning/watercatcher. Solar, wind generator, HF radio, new VHF radio, sea anchor, drogue, 4 anchors. High bridgedeck clearance insures no pounding. Retractable centerboards for upwind performance. Solid handrails for safety. Free delivery. For specs and pictures email Evan Dill: revandill@yahoo.com.

POWER & HOUSEBOATS

43.5-FT LABELLE TRAWLER. Sausalito outstanding view berth. Volvo diesels, 500 hours, 7.5 Onan. Roomy glass-enclosed sundeck. Full canvas. Large custom galley. Master with walkaround queen, tub + comfortable guest stateroom with large bed, head. Excellent workmanship/condition. Will sacrifice. May finance, rent or trade. (415) 331-5251.



31-FT CRUISE-A-HOME, 1972. Delta. \$7,495. Sleeps 4. Galley, pressurized water, head, shower, swim platform. Generator, stereo, VHF, microwave, electronic ignition on twin 300 hp OMC V8s, new outdrive. 11+ knots. Comfortable, seaworthy. More pictures at: www.deltadrifter.com. (916) 777-5510 or (408) 279-4435 or mail@deltadrifter.com.

28-FT PROTECTOR, 2001. Lake Tahoe. Beautiful center console Protector. 99% fresh water use. Two 225-hp Yamahas, under 400 hours. Teak sole. Rear seat. GPS/chartplotter. VHF. Excellent condition and very fast. (530) 583-4000, (530) 518-8500 or GD@DorlandProperties.com.



28-FT UNIFLITE TWIN-ENGINE SPORT. boat, 1972. San Francisco. \$24,000. Two brand new engines (35 hours each), new mechanical throughout. Fridge, stove, toilet, two sinks, shower, GPS, radar, fishfinder. (415) 710-4900.



65-FT WOOD CLASSIC, 1939. Heavy built ex-trawler. GMC 12V-71, 21-kw generator. Full electronics. Lots of equipment. Ready to go. Would make great conversion. Will consider any reasonable offer. More pics/details: (707) 964-5423 ancona@mcn.org.

50-FT DEFEVER OFFSHORE TRAWLER, 1971. Sausalito. \$195,000. Two personalities - robust offshore trawler capable of going anywhere - cozy, comfortable live-aboard home (owners now live aboard). All info on line at: www.synjyn.com. Call (415) 331-3387 or (415) 717-2314. Email: chuck@synjyn.com.



53-FT HATTERAS, 1970. Berkeley Marina. \$119,000. Flybridge motor yacht. New dishwasher. Twin Cummins VT8-370M Turbo. 2500hrs. Generator: EnTec Power Plants, Model M4. Dinghy: Alliance 12', Mercury 25 hp. Liveaboard status possible. Must see to appreciate. (510) 725-9942 tcparfitt@yahoo.com.

PARTNERSHIPS



35-FT J/109, 2004 BELVEDERE, CA. J/109 sailboat partnership. Mint condition J/109. Active SF racer/cruiser. 1st in SF Bay J/109 Division, 3rd in 2008 PHRF. Also, great family cruiser, sleeps 6+, full kitchen, for Delta, Bay or coast. Interested parties only: (415) 717-3664 or (415) 819-4589 or email ahoy@earthlink.net.

PARTNERSHIP ON 30' OCEAN GOING sailboat, Berkeley/Emeryville Marina. \$300 per month 1/3 share. Bruce Roberts (1982): world cruiser. Full keel, new paint, windlass, hot water/shower, wheel, Volvo, inverter, stereo, DVD/flat screen TV. Email: yaski@inspiremyevent.com or call (650) 533-5487.

IRWIN 43 MRK III SO BEACH HARBOR. Looking for a compatible partner to share this great sailboat. Ideal SF Bay location. Flexible terms for the right person. Boat is valued at \$115,000. (831) 688-2246, (408) 505-9328 or tenrightca@sbcglobal.net.



SOUTH OF THE BORDER

CONDO RENTALS NEAR VALLARTA Yacht Club. Two adjacent condos overlooking Paradise Village Marina. Each 2 br, 2 bath with Jacuzzi, pool and amenities. Access to Sports & Beach Club. Rent one or both. Call (925) 208-1601 or (011) 52-322-297-7559. Email: nwardmoore@gmail.com.

MULTIHULL DELIVERIES

30+ years & 150,000 miles on multihulls • Safe, swift, dependable worldwide deliveries by USCG licensed ASA instructor Capt. Ralph Drahos
(831) 334-6028 • Owners welcome
Learn multihull sailing and your boat's systems with a professional

MARINE ENGINE CO.

Complete Engine Services • Gas & Diesel
30 Years Experience • Reasonable Rates
Tune-Ups • Oil Changes • Engine Rebuilding, etc.
(415) 332-0455

YOGA FOR SAILORS ON THE SAN RAFAEL WATERFRONT



Classes on Wednesdays (flow) & Thursdays (restorative), 6:30-8:00 pm, beginning 10/7. Special post-Vallejo 1/2 class on Monday, 10/12 at noon. (415) 785-4530 or (510) 333-8846, yogaforu2009@gmail.com

MULTIHULL YACHT DESIGNER • MARINE SURVEYOR

John R. Marples, CMS • Certified, National Association of Marine Surveyors
Multihull Design Specialist • Pleasure and Commercial
Design office for Jim Brown Searunner, Seaclipper & Constant Camber Multihulls
www.searunner.com • (707) 343-1378 • marplesmarine@comcast.net

CLASSIC FANTAIL MOTOR LAUNCH



BUSINESS OPPORTUNITY

29-ft launch, Coast Guard certified for 18 passengers plus captain (no crew required). Built in 1993 of fiberglass, teak and brass. 35hp Isuzu diesel, trailer.
Currently working in SF Bay with business available! **\$65,000.**
Serious inquiries call **(415) 781-3950** for details.



*A Sailor's
Consignment
Chandlery*

Official
Sponsor
2009
BAJA
HA-HA

510-769-4858

Located at Grand Marina
www.bluepelicanmarine.com



MORE ENERGY!

KEEP BATTERIES CHARGED!

- KISS wind generators
- Solar panels and MORE

USE BATTERIES EFFICIENTLY!

- LED lights
- Engel fridge/freezers
- Port fans and more



See us at
the Annapolis
Boat Show

www.svhotwire.com 727.943.0424

Bilge Steam Cleaning Oil Changes

Professional service at your slip!!!

MarineLube

www.MarineLube.biz

877 744-2244



Fuel Polishing

Tank Cleaning



PLAN YOUR MEXICAN GETAWAY NOW.

at the brand-new, gorgeous Cielo Y Mar condos. Located in Punta Mita, 35 minutes from Puerto Vallarta, available to rent from private owner. On the beach, 10 feet from the water, they offer spectacular views of ocean and mountains, the biggest infinity pool in the area, an endless beach, great surf breaks, great fishing, tremendous views of whales, bird life and the islands. While uncrowded and tranquil, just a five-minute walk to several waterfront restaurants. Choose from a spacious, beautifully furnished one- or three-bedroom unit, or an amazing two-story penthouse with lovely shade trellis on the top floor. To reserve, call Dona de Mallorca (415) 599-5012. See details: www.puntamitabeachfrontcondos.com.



CHARTER DIRECT & SAVE \$\$\$\$. Owners time available for discount charter. Beautiful Moorings 4600 cat, *Hope*, featured in *Latitude 38*. Based in beautiful Belize. Book direct and save big bucks. dpetty@thoratec.com.

EXPERIENCED MEXICO CRUISER. seeks use of your sailboat in Sea of Cortez for 2-4 weeks this June/July. Great chance to replenish your cruising kitty or help pay for trucking boat home. Willing to help with transit to Mexico. Call (775) 450-3007 or email altairsf@yahoo.com.

WANTED

30-34-FT SLOOP WANTED. Looking for a boat that I can berth in the upper harbor in Santa Cruz (the only place I can get a slip here). Must be able to be tabernacled if it isn't already. Prefer a boat that can be single-handed. Other must haves: diesel engine, furling jib, ready to sail, clean condition, well taken care of. Call (831) 234-0183 or email linz1@cruzio.com.

GEAR

74-FT MAST DESIGNED for catamaran. Best offer. Call (415) 269-5165.

CATALINA 42' MAIN SAIL. (New, never used) Ventura, CA. \$3,200. New, still in the bag. Our boat sold. Purchased from Catalina Yachts in WH CA, full batten, 2 reef, w/new 3 line Dutchman flaking system. Call (805) 732-9234 or (805) 418-7175. Email: dab.fd67@yahoo.com. Mailing: 1784 Country Oaks Lane, Ventura, CA.

SPECTRA NEWPORT 1000 watermaker. Marina Village, Alameda. \$4500. Overhauled and in working order, makes 40 gallons of water per hour. Call (530) 518-8500 or (530) 386-3832. Email gd@dorlandproperties.com.

PUR-35 POWERSURVIVOR watermaker. \$800. Used once. All the extras. Air-X wind generator, \$350. Icom M700 single-sideband radio with antenna tuner, \$400. Yukon 10-ft inflatable, very rugged, \$300. 15hp Evinrude, \$300. Call Mike (415) 312-3364.

MISCELLANEOUS

ELECTRIC BOAT MOTOR. Mill Valley, CA. \$2,500. Our sealed 2kW electric motor is designed for severe marine environments from the shaft up. Made from CNC'd billet, the housing contains both the motor and controller, eliminating messy interconnects and contactors. The simple unit is designed to be bolted directly to the prop shaft, is provided with hermetically sealed controls, and will operate service free for many, many years. Come see our Ericson 27 for a test ride. www.advancedmarineelectricpropulsion.com. Call (415) 299-0312 or arby@advancedmarineelectricpropulsion.com.

50-FT DOCK AND/OR HOME. For lease, Alameda Estuary. \$400/\$2850. Private 50' Dock, \$400 + 3 BR, 2 bath gorgeous totally remodeled home. Kitchen and LR overlook water, bamboo flooring, custom tile and fixtures. Bring water toys! \$3,200 includes dock. (707) 695-3284 or email svjazz@msn.com.

CLUBS & MEMBERSHIPS

SINGLE SKIPPERS AND CREW. of all abilities are invited to join the Single Sailors Association. Membership includes daysailing, raft-ups, invaluable onboard training, social events. Meetings held 2nd Thursday, Ballena Bay Yacht Club. See: www.bbvc.org. Social 6:30 pm. Meeting 7:30 pm. Guests welcome. Call (510) 233-1064. See: www.singlesailors.org.



BLUE PELICAN MARINE

A sailor's consignment store located at Grand Marina, Alameda
Sails • Winches • Instruments • Blocks • Sailing Books
Charts • Outboards • Rigging • Hardware • Safety Gear • More
(510) 769-4858 • www.bluepelicanmarine.com

UNIQUE 3-STORY CUSTOM HOUSE - REDUCED \$200,000

Point Richmond • 4 Bedrooms • 3.5 Baths • 2 Deepwater Docks
Dramatic 3-story foyer with cylindrical pneumatic elevator
850 sq ft in-law unit with private entrance and garage
www.tombrichta.com • Tom Brichta • (510) 965-1754

NON-PROFIT

3 BOATING CLASSES. Offered by USCG Auxiliary Flotilla 17 at Yerba Buena Island. About Boating Safely 10/17; How To Read A Nautical Chart 10/24; GPS for Mariners 11/7. \$55 each; \$135 for three. Contact for details. (415) 285-1100 or email FSO-PE@flotilla17.org.

MARIN POWER & SAIL SQUADRON. 50 years offering tuition-free safe boating classes. America's Boating Class started September 15, Tuesdays and Thursdays, 7 to 9 pm in Novato. Textbook \$40. For registration and information, call (415) 924-2712.

PROPERTY SALE /RENT



HAWAIIAN OCEANFRONT: BUY/RENT. Oahu's north shore. 3br/2bath totally remodelled home, 32 feet from water. Unique, secluded enclave offering expansive sandy beaches, water sports, historic towns, small harbor nearby. Rent to *Latitude 38* readers starts at \$185/night. Some conditions apply. May sell partnership or trade for California property. Let me help you find your Hawaiian dream. (415) 999-5626.

LUXURY WATER FRONT LIVING. 65-ft. deep water dock. San Rafael, CA. \$1,550,000. 4/4 Gorgeous! Chef's kitchen, 2 fireplaces, wine cellar, hot tub. Amazing home! See www.17Sorrento.com. Call (415) 717-4242 or (415) 292-5522. Email CassidyRE@aol.com. Mailing address: 1766 Union Street, Suite C, SF, CA 94123.

BERTHS & SLIPS

50-FT PRIVATE DOCK. Alameda Estuary. \$400/month + electricity. Sailboat preferred. Cruisers swallowed the anchor, have lonely dock. Lease preferred or month to month. (Also fully remodeled 3 Br, 2 Bath house with view and access to water for lease.) Call (707) 695-3284 or email svjazz@msn.com.

BERTH AVAILABLE SAN FRANCISCO. 36-ft berth at Pier 39. Very close in. Rental by month or annually. (415) 474-2474.

PIER 39, 36-FT SLIP SAN FRANCISCO. \$9,500. Ideal location. All amenities. Too many to mention. Sail the Bay and enjoy The City, all from your home base at Pier 39. Call Sally (510) 525-7613.

SAN FRANCISCO BOAT BERTH. E46, Pier 39. \$12,000. Terrific location. Looks up to Telegraph Hill. Possible liveaboard. 40 x 14. Leased to 2034. Currently rented month to month. Best offer. Cash only. Contact Pier 39 Harbormaster to view berth. Bruce Woelfel. (602) 999-0016.

50-FT PRIME SLIP PIER 39, SF. \$46,000. F-Dock, Slip 11, east side. Protected from wind. Close to gangway, showers and marina office. Covered parking across street with special rates for owners. Email scorch@tempest-edge.com or call (559) 355-6572.

JOB OPPORTUNITIES

SAILING AND POWER BOATING. Instructors wanted. Award winning Club Nautique is seeking friendly instructors with solid boating and people skills for part-time teaching in Alameda and Sausalito. We have the newest fleet on the Bay and the most active Coastal program in the nation. Advance your skills, work with professional staff and have fun on the water. Includes boat use privileges and membership benefits. Licensed captains email schooldirector@clubnautique.net or call (510) 865-4700.

PERSONAL ASSISTANT. And/or boatworker. One or two people, pt or ft, help with business, organization, upgrading boats. Interests in mortgage and real estate brokerage, boat remodeling, sales. Sausalito. Ability to travel a plus. Lodging possibly included. Call (415) 331-5251.

BUSINESS OPPORTUNITIES



FOR SALE: WELDING BUSINESS. Brinnon, WA. \$595,000. Welding business in 4,200 s/f building with 3-phase power on 9+ acres on the Olympic Peninsula near 2 saltwater marinas which provide partial client base. Comfortable 2 bedroom, 2 bath home with oak floors, vaulted t&g ceiling, large kitchen with Corian counters, auxiliary generator and cedar deck plus oversize 2-car garage with ample storage and an upstairs guest room with bath. Business, home and acreage. Owner financing possible. Email broweld@olympen.com or call (360) 796-4163.

SHOP SPACE 500-1000 SQUARE FEET. Sausalito. To share, possible buy out. Good location. Call (415) 332-2500.

2010 COMING SOON!

2009 Northern California SAILING CALENDAR AND YRA MASTER SCHEDULE

Complete Racing Guide

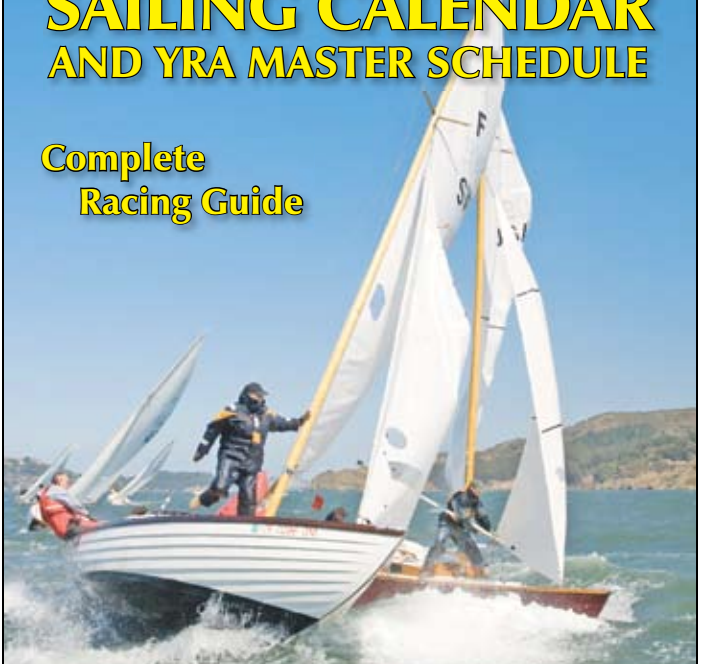

Latitude 38
Publications

FREE! Pick one up

Check out Rob Grant's
'Weekend Racing Wrap-Up'
(almost) every Monday on
'*Lectronic Latitude!*



'BETTER LINKS'

On Line • In Print • On the Bay

Fully linked and comprehensive
resource for racing the Bay.

Promote your club, class, events or products.

(415) 383-8200



JUST YOU AND THE SEA...



...and the jacuzzi,
the 80-ft long pool, the surf,
the Punta Mita anchorage, and the 4-mile distant
Tres Marietas Islands

Punta Mita Beachfront Condos

Call Doña de Mallorca for reservations!

1.415.599.5012

www.puntamitabeachfrontcondos.com

Latitude 38 eBooks

Available Worldwide

**FREE
Downloads**

Available at

www.latitude38.com

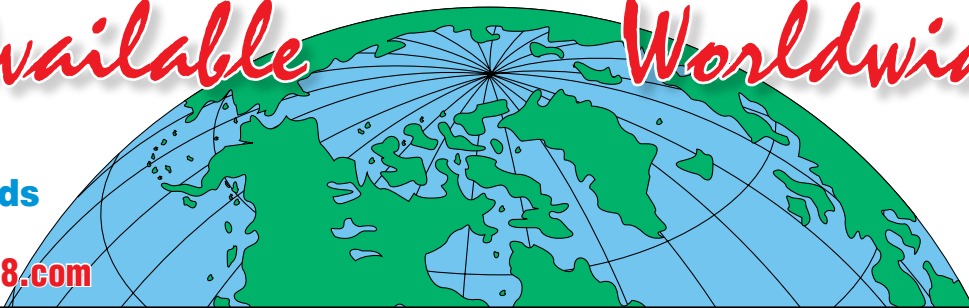

No matter where
you find yourself,
you can still get lost
in the pages of
Latitude 38

weatherguy.com

Worldwide Marine Forecasts Cruising, Racing & Commercial

Packages Starting at \$65.00 USD

(866) 882-WXGY (9949) toll free
(808) 291-WXGY (Mobile)
(808) 254-2525 (Office)
(808) 443-0889 (Fax)



970 N Kalaheo Ave
Suite C-104
Kailua, Hawaii 96734
info@weatherguy.com

www.weatherguy.com



Save Your Aft!

Using one of our 1400+ patterns or your own pattern, let our craftsmen create a comfortable, durable, and stylish set of all-weather cushions for your cockpit. Find your custom, closed cell foam cushions at www.bottomsiders.com!

BottomSiders

BottomSiders
2305 Bay Avenue
Hoquiam, WA 98550

Call Toll Free: (800) 438-0633
cushions@bottomsiders.com
Fax: 360-533-4474

Mathiesen Marine

For All Of Your Electrical & Electronic Needs

Professional installations by an
ABYC Certified Master Technician

Your source for all major brands
of marine electronics at great prices

Electronics, PC & Mac based Navigation
Systems Integration, Radar, Autopilots
Corrosion Issues, Inverters, Battery Banks

(510) 350-6622 www.MathiesenMarine.com



-Fully Insured-

Simply Great Sleep



Transform your mattress with our
box-spring system and enjoy many
relaxing nights aboard.

Froli

phone 888.463.7654
Nickle Atlantic, LLC
www.FroliSleepSystems.com



DONATE YOUR VESSEL



- Donate your boat or equipment for a tax deduction
- Learn about our For Sale by Owner program plus tax deduction
- Topside cleaning service, \$2.00/foot

Fundraiser for Ship 65 Sea Scouts
and Maritime Learning Center
www.seaeagle.homestead.com

650-380-5535

ATLANTIC 57 CATAMARAN™



THE ORIGINAL PILOTHOUSE CATAMARAN
o Designed for easy shorthanded cruising
o Spectacular windward performance
o Cored epoxy/glass/carbon construction
CHRIS WHITE DESIGNS
TEL: 508-636-6111
www.chriswhitedesigns.com

RPARTS

REFRIGERATION PARTS SOLUTION

WE MAKE YOU THE EXPERT

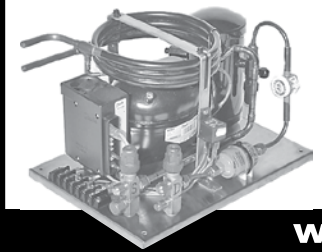

"Do-It-Yourself" with RParts
at unbeatable prices. We
can help you fix a system
or build it new.

Assembled Water-Cooled DIY Kit shown

www.rparts.com

COMPUTER ABOARD?

CAPN & Digital Charts
AIS • WiFi • Cellular Amps
SatPhones: Iridium & Globalstar
HF SSB Radio & Pactor Modems
Wireless E-mail

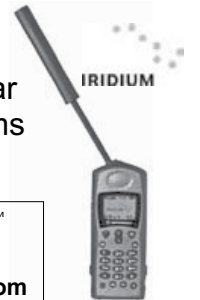

SEATECH SYSTEMS™

800.444.2581 • 281.334.1174
info@sea-tech.com • www.sea-tech.com

Call for Info on SeaTech Packages and CAPN Demo Disk

ADVERTISERS' INDEX

AB Marine.....56	Baja Tourism Board47	Blue Sky Energy.....159	C & C Marine Services.....116	Costa Baja Resort & Marina...39
Albatross Yacht Charters.....147	Ballenger Spars.....139	Blue Water Yacht Insurance ..60	Cal Marine Electronics.....49	Cover Craft.....102
Almar Marinas51	Barillas Marina.....158	Bluestorm61	Call Of The Sea147	Coyote Point Marina.....41
Altmount.....30	Bay Island Yachts.....12	Bluwater Network.....182	CDI/Cruising Design127	CPT Autopilots.....172
American Battery.....180	Bay Marine Boatworks.....43	Bo'sun Supplies.....170	Chula Vista Marina163	Cruising Cats USA.....57
Anacortes Yacht Charters146	Bay Marine Diesel170	BoatSmith Marine Carpentry and Boatbuilding.....69	City Yachts11	Cruising Yachts.....16
Anderson's Boat Yard33	Bellhaven Yacht Sales & Charters.....146	Boatswain's Locker71	Classic Fantail Motor Launch.....174	CYOA Yacht Charters145
Annapolis Performance Sailing137	Berkeley Marina111	Bob Craven Yacht Sales.....186	Climb the Mast.....170	Danard Marine Products.....59
Baja Ha-Ha Beach Party115	Berkeley Marine Center.....35	Bottom Siders.....176	Clipper Yacht Harbor.....172	Dept. of Boating & Waterways53
Baja Ha-Ha Sponsors..... 121,122,123	Beta Marine Engines65	Brisbane Marina.....57	Coast Marine172	Desolation Sound Yacht Charters.....146
	Blue Pelican 174,176	BVI Yacht Charters.....145	Conch Charters.....147	

THANKS!

Another Advertising Success Story...



Tom and Shelly Bliss, owners of Blue Pelican Marine in Alameda.

Early in 2009 Tom and Shelly Bliss thought the time was right for a new marine consignment shop in the East Bay. They jumped right in and founded *Blue Pelican Marine* located in Grand Marina, Alameda.

The first thing they had to do was to get the word out and one of the first places they turned to was *Latitude 38*. They came aboard as sponsors for the 16th annual Baja Ha-Ha and took out a display ad in the magazine. We're happy to report the business has been flourishing ever since.

It's clear they had the right idea and the right timing with environmental responsibility and economics guiding everyone to reuse rather than discard products no longer needed. They've built a great inventory, and now have many happy customers from the Baja Ha-Ha fleet and *Latitude 38* readership. Welcome aboard and thanks for joining us!

www.bluepelicanmarine.com • www.latitude38.com

State Farm®

Providing Insurance and Financial Services



Call Us For A FREE Quote Today

Jon Jones, CLU ChFC LUTCF

Agent Lic. #0540977

(650) 583-3927

333 El Camino Real, Suite A • So. San Francisco, CA 94080-5923
jon.jones.b8c4@statefarm.com

QUALITY CRUISING SAILS FOR LESS!

LEE SAILS

NOW
**10%
OFF**

**MAINSAILS
MIZZENS
STAYSAILS
HEADSAILS
SPINNAKERS
SAILCOVERS
STRONGTRACK**

(510) 523-3337 • leesailsnc@yahoo.com

2021 Alaska Packer Pl. • Grand Marina • Alameda, CA 94501

SAILMAKER TO THE WORLD

ADVERTISER'S INDEX - cont'd

DeWitt Studio.....180	Essex Credit Corp.....69	Grand Marina2	Hydrovane8	Larry R. Mayne Yacht & Ship Broker.....23
Diesel Fuel Filtering.....179	Fago, Margaret Artist59	Hansen Rigging.....139	Johnson Marine, C. Sherman.....68	Latitude 38 E Book176
Downwind Marine.....18	Farallone Yacht Sales7	Harken46	Johnson-Hicks.....138	'Lectronic Latitude146
Doyle Sails.....27	Flying Cloud Yachts186	Helmut's Marine Service.....178	Katadyn119	Lee Sails178
Driscoll Mission Bay Marina.181	Footloose Yacht Charters.....144	Heritage Marine Insurance.....103	Kissinger Canvas.....73	Lifeline Batteries.....102
E Paint65	Forspar34	Hidden Harbor Marina.....10	KKMI - Brokerage.....183	List Marine Enterprises10
Easom Rigging97	Fortman Marina75	Hogin Sails50	KKMI - Full Service Boatyard188	Loch Lomond Marina103
Elliott/Pattison Sailmakers ...138	Garhauer Marine45	Holmatro USA.....20	Lagoon America.....25	Lunasea Lighting.....75
Emery Cove Yacht Harbor.....65	GC Marine.....136	Hood Sails37	Landfall Navigation.....73	Makela Boatworks.....181
Emeryville Marina127	Gentry's Kona Marina146	Hotel Coral & Marina160	Landing School, The111	Marina Bay Yacht Harbor.....55
Ensenada Cruiseport Village159	Gianola Canvas Products168	Hotwire Enterprises174		Marina de la Paz114
	Golden State Diesel Marine.180			

Sale!

15% Off All New & Used Stock Sails!

Fall Discounts are now in effect!
15% off all new and used stock sails purchased online. Sale Ends 12/31/09

We stock the worlds largest selection of pre-made stock sails for common production boats in the world. We have over 1,000 New & Used sails in stock!

The Sail Warehouse
 www.thesailwarehouse.com 831.646.5346

MARINE OUTBOARD COMPANY

Johnson
 Evinrude
 Mercury
 Nissan



Tohatsu
 Mariner
 Honda
 Yamaha

(415) 332-8020

Our certified technicians have repaired, rebuilt, repowered and serviced outboards and boats since 1990 for less than anywhere else in the Bay Area. How? Less overhead... All repairs and parts come with a 1-year warranty; 3-year warranty on new Nissan engines.

35 Libertyship Way • Sausalito, CA 94965

WEDLOCK, RAMSAY & WHITING
 Marine Surveyors

Vessel surveys,
 consulting, deliveries.

Serving the
 Bay Area
 since 1980



www.norcalmarinesurveyors.com
(415) 505-3494

DF DIESEL FUEL FILTERING



Purify Diesel Fuel & Flush Tanks

Process scrubs, polishes, removes algae, dirt, sludge, rust, water, and foreign particles from diesel fuel. Includes internal tank washdown. Save your injectors, costly engine repair and down time.

Since 1989. Fully insured. Your berth or boat yard.

(510) 521-6797 Fax: (510) 521-3309

www.dieselfuelfilterings.com

Ryan's Marine
Specializing in Marine Electrical Services for Your Boat

- Electrical system installations from inverters to electronics packages
- Troubleshooting of existing systems
- Dealer for the complete Balmar product line
- Head and holding tank installations

MEMBER
ABYC
Setting Standards for Safer Boating

(510) 385-3842

Ryan Schofield
 Owner since 1997

email:
rssailor@yahoo.com

Vessel Electric
Mobile marine navigation installations and expansions of existing systems

- Class A, Class B AIS systems and digital TVs
- Raymarine® warranty dealer and certified installer
- NMEA-certified Marine Electronics Installer • Insured

Raymarine Milltech Marine AIS **NAVPOD**

Brian Theobald • (415) 424-2204
vesselelectric@yahoo.com

ADVERTISER'S INDEX - cont'd

Marina El Cid.....162	Marotta Yachts 184,185	Neumann & Bennetts/ Plasti-Duk61	Oyster Cove Marina58	Quantum Pacific.....17
Marina Mazatlan.....120	Mathiesen Marine177	Nickle Atlantic/Froli Sleep Systems.....177	Oyster Point Marina102	R-Parts177
Marina Nuevo Vallarta72	Mazatlan Marine Center/ La Paz Yachts.....10	Norpac Yachts187	Pacific Crest Canvas61	Raiatea Carenage Services.....161
Marina Puesta Del Sol.....163	McDermott Costa Insurance ..75	North Beach Marine Canvas49	Pacific Yacht Imports.....9	Randall Burg Yacht & Ship ...186
Marina Real162	McGinnis Insurance.....160	North Direct Sails.....164	Paradise Village31	Richardson Bay Marina.....126
Marina Riviera Nayarit117	Milltech Marine Inc.....54	North Sails - San Francisco...66	Pardee Marine181	Rooster Sails138
Marina Village19	Minney's Yacht Surplus.....181	Open Sailing/Open 5.70....136	Passage Yachts5	Ryan's Marine179
Marine Emporium64	Moorings, The.....145	Opequimar Marine Center..164	Peter Crane Yacht Sales.....182	Safe Passage Sailing.....67
Marine Lube.....174	Modern Sailing School & Club29	Outboard Motor Shop40	Pier 32 Marina165	Sail California14,15
Marine Outboard Co.....179	Napa Valley Marina Yachts 181,182	Owl Harbor.....73	Pineapple Sails.....3	Sail Warehouse, The179
Mariner's General Insurance.....70			Punta Mita Beachfront Condos176	Sailing Supply52
Maritime Institute67			Pusher's Rum.....4	Sal's Inflatable Services69



City by the Bay

deWitt

NEW HAPPENINGS at DEWITT GALLERY!

Starting October 1, come see all the changes here at the Gallery in Point Richmond.

Point Richmond Art Collective

Paintings ~ Photography ~ Jewelry
Sculpture ~ Glass

Grand Opening Reception

Saturday, October 24, 2:00-7:00 p.m.

DeWitt Art Gallery & Framing
121 Park Place, Point Richmond, CA 94801
(510) 236-1401 ☎ (800) 758-4291

www.jimdwitt.com ☎ www.dewittgalleryandframing.com

Tuesday-Thursday 11:00-5:00 ☎ Friday 11:00-3:00 ☎ Saturday 12:00-5:00

GOLDEN STATE DIESEL MARINE

PARTS
YANMAR • UNIVERSAL • WESTERBEKE
PERKINS • ISUZU • PATHFINDER • ATOMIC 4

SERVICE
DIESEL ENGINES

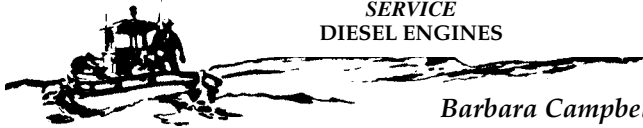

Barbara Campbell

351 EMBARCADERO
OAKLAND, CA 94606

(510) 465-1093



AMERICAN BATTERY

MARINE BATTERIES

LIFELINE
...the heart of your system®

Available at the following local marine chandleries and service distributors:

ALAMEDA

- Alameda Prop & Machine
- Fortman Marina Store
- The Boatyard at Grand Marina
- Star Marine
- Svendsen's Chandlery

BENICIA

- Cruising Seas Services

MARTINEZ

- Diablo Marine

OAKLAND

- Golden State Diesel
- Outboard Motor Shop

OAKLEY

- Big Break Marina

RICHMOND

- Swedish Marine
- Bay Marine

SAUSALITO

- Sausalito Marine



AMERICAN BATTERY • Hayward, CA • (510) 259-1150

ADVERTISER'S INDEX - cont'd

San Francisco Boat Works.....59	Seatech.....177	The Boat Yard at	Velas de Loreto/'El Don'.....118	White, Chris Designs.....177
Santa Rosa Boat Center.....32	Seaworthy Goods.....63	Grand Marina.....13	Ventura Harbor Boatyard....165	Wright Way Designs.....71
Sausalito Marine Electrical	Shadetree Fabric Shelter.....116	The Dinghy Doctor.....158	Vesper Marine.....165	Yachtfinders/Windseakers.....8
Shop/Artisan Marine.....114	Society of Accredited Marine	TMM/Tortola Marine	Vessel Electric.....179	
Scanmar International.....42	Surveyors/SAMS.....168	Management.....147	Voyager Marine.....165	
Schaefer Marine.....110	South Beach Harbor.....48	Tradewinds Sailing.....71	W.D. Schock Corp.....67	
Schoonmaker Point	South Beach Riggers.....49	Trident Funding.....6	Weatherguy.com.....176	
Marina.....107	Starbuck Canvas.....8	Twin Rivers Marine	Wedlock, Ramsay & Whiting	
Sea Frost.....63	State Farm Insurance.....178	Insurance.....62	Marine Surveyors.....179	
Sea Marine Yacht Service &	Sun Harbor Marina.....118	UK-Halsey Sails.....126	West Marine.....22,24,26,28	
Sales.....182	Svendsen's Boat Works.....21	Ullman Sails.....38	West Marine - Rigging.....74	
Sea Scouts.....177	Svendsen's Marine.....127	Vallejo Marina - Fuel Dock....63	Westwind Precision Details....49	
Seashine.....57	Swedish Marine.....111	Vallejo Marina - Guest Dock..44	Whale Point Marine Supply....36	



Baja~Bound Cruisers

10% OFF Bottom Job*

Driscoll
MISSION BAY
Boat Yard & Marina

*Do-It-Yourself
Welcome*
(619) 221-8456

www.driscoll-boats.com

*valid to
12/1/09

Since many boat fires have an electrical cause,
you've got to ask yourself one question...

IS YOUR ELECTRICAL SYSTEM OKAY?

*Call today to schedule a
22-Point Basic Electrical System Inspection*

Limited time offer only \$2 per foot

Mike Pardee
Pardee Marine, LLC
(510) 282-7282



1,000 Used Sails
Listed at
minneysyachtsurplus.com

**We Buy Good Used Sails
and Marine Equipment**

MINNEY'S YACHT SURPLUS

1500 Newport Bl., Costa Mesa, CA
949-548-4192 • minneys@aol.com

"We keep boating affordable!"

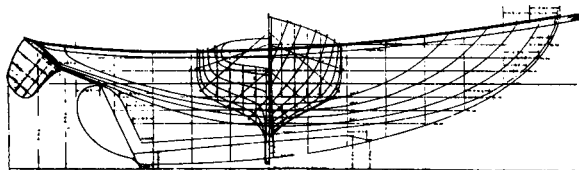

MAKELA BOATWORKS

Family owned since 1948

Wooden Boat Building • Repair and Restoration

19280 South Harbor Drive • Fort Bragg, CA 95437

(707) 964-3963

email: howard@makelaboatworks.com • www.Makelaboatworks.com

CELEBRATING OUR 50TH ANNIVERSARY



35' SANTANA
1979, clean • \$16,500



43' SERENDIPITY
1982 • \$36,500



37' PROUT SNOWGOOSE CAT
1985 • \$79,000



37' ISLANDER
1968, nice interior • \$24,900



40' MARINER KETCH
1973 • \$29,900



41' MORGAN OUT ISLAND
SLOOP, 1974 • \$34,900



41' ATKINS INGRID FERRO
CUTTER, 1971 • \$24,900



47' COLIN ARCHER STEEL PH
KETCH, 1972 • \$69,500



39' PEARSON 390 CENTER
COCKPIT • 1972 • \$42,500



36' UNION CUTTER
1980 • \$33,777

DRY STORAGE
\$4.00/ft
Power & Sail



36' PEARSON 365 KETCH
1976 • \$25,500



NAPA VALLEY MARINA YACHTS

(866) 363-8882 • (707) 252-8011

1200 Milton Road • Napa, CA 94559

www.napavalleymarina.com

Marina • Boatyard • Chandlery • Brokerage

Dealers for
YANMAR

Interlux
yachtpaint.com

Distributors for *Brownell*
Boat Stands

TWO VERY SPECIAL LISTINGS FROM NAPA VALLEY YACHTS

56' FOUNTAINE PAJOT MARQUISES 2001 • \$695,000



Most spectacular salon of any yacht in its class. Large galley complete with bar and built-in seats; wrap-around dinette accommodates 10. Impressive navigation center with all the latest electronics.

Entire starboard hull dedicated to the captain's stateroom. Two large staterooms with their own private heads to port. More than 1,000 sq. ft. of deck space. Low hours on twin Yanmar 75hp direct drive diesel engines.

This yacht is in immaculate condition and is priced to sell.

50' CLASSIC SCHOONER \$18,500



Simply a legendary yacht.

Mavourneen Mary (formerly *Landfall II*) was built in the '30s by Boeing for actress Maureen O'Sullivan.

Circumnavigated by Dr. W.F. Holcomb from 1953 to 1957.

Own a legend. Needs work.

Both of these unique yachts are priced to sell. Call us today to schedule an appointment.

(707) 732-6101

NAPA VALLEY MARINA YACHTS

(707) 252-8011



Peter Crane Yacht Sales

a different kind of yacht brokerage

We can help find the right vessel
for exciting adventures
in sailboats and powerboats

Contact us with your specifications
we will search preview
assess and photograph
the best candidates

searching for interesting boats interesting people

(805) 963-8000
pc@petercraneyachts.com

Donate your Boat

Cars, Trucks, RVs, & Real Estate

We handle all DMV & Smog

Running or Not (restrictions apply)

Tax Deduction

BLUEWATER NETWORK | **800-324-7432**

"Proceeds help Bluewater Network reduce greenhouse gases, clean up our air and water, and protect marine mammals and wildlife."



Contact
Larry Bond
Broker

Larryb@seamarineco.com

Local: 360-385-4000

Free: 800-952-6962

419 Jackson St.
Port Townsend, WA 98368



Lapworth 50, built to race the Transpac.

A proven blue-water racer/cruiser,
total rebuild/refit 1997-2002.

\$175,000

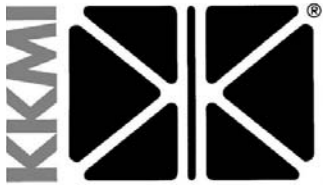

Maritime

Yacht Brokerage

☎(510) 236-6633 • fax: (510) 231-2355

yachtsales@kkmi.com • www.kkmi.com

530 W. Cutting Blvd., Pt. Richmond, CA 94804

LIST WITH US!

Ask us about our
Maritime Protection
Program to find out what
a warranty can do for
the sale of your yacht!



Nelson Marek Custom
A 92-ft aluminum world cruiser.
Recently repowered. Immaculate
throughout and in perfect condition.
\$2,850,000



Herreshoff 'Mobjack' Ketch (1989) This classic wooden ketch took more than 8 years to complete. Exceptionally well maintained w/a very comfortable and appointed interior layout, she has excellent sailing characteristics for cruising in all weather conditions. **\$180,000**



Sydney 36 CR (2006) w/fractional rig, 4 swept-back spreaders, non-overlapping head sail, high aspect ratio & very long waterline. Competitive IRC racer. Fitted w/all factory options incl. electric winches, ideal for short-handed sailing. Consider trade such as 'picnic' style powerboat. *Encore's* fast, fun & easy to sail. **\$279,000**



Beneteau First 40.7 (2001)
White Dove won the 2008
West Coast IRC Championship
and is in top condition.
Asking **\$160,000**



DeVries 86' Motor Vessel (1949/1999)
'Elegant', 'Exceptional', 'Exquisite' are just a few words that easily characterize this vessel. *MV Far Niente* clearly defines the term 'Classic Motor Yacht'. Asking **\$1,950,000**



Custom Steel Pilothouse LRC 63 (1976)
Ready-to-go global cruiser just completed \$100,000 maintenance/upgrade service. Twin 185hp Perkins for economy and dual gensets. Three cabins + crew's quarters. Asking **\$339,000**



Little Harbor 51 (1996)
A very comfortable Ted Hood designed pilothouse with full stand-up headroom and 360° visibility. Set up for shorthanded sailing and superbly maintained by an experienced owner.
Asking **\$669,000**



Swan 53 (1987)
Mistress has been exceptionally well maintained by a professional crew and is a beautiful Swan 53. Her factory-installed aft companionway makes her much more accessible than the standard 53. She has a new teak deck and is in excellent shape.



Swan 43 (1977)
Designed by S&S and with the Nautor Swan pedigree for engineering and construction, this one-owner center cockpit yacht is exceptionally maintained, fully outfitted and ready to go offshore cruising. It is a 'Must See'. Asking **\$149,000**



Swan 45 (2003)
Race or cruise. *Rancho Deluxe* won her class in the TransPac and was second twice in the Big Boat Series. This boat has all the gear to go cruising and is in perfect condition. **\$625,000**



Swan 371 (1981)
A Ron Holland design which is very well equipped with newer electronics, sails and has been well maintained.
Asking **\$120,000**



Swan 40 (1996)
Frers design, exceptionally well maintained, 2-cabin performance cruiser. Awlgrip Flag Blue hull, comprehensive sail inventory, and full in-slip cover. Asking **\$309,000**



Marotta Yachts

Join us in welcoming Phil Howe – adding 30+ years of

See at: www.marottayachts.com



42' CATALINA, 2005

Absolutely gorgeous, low time and loaded – this boat shows as new! Transferable Sausalito Yacht Harbor slip. **\$249,000**

See at: www.marottayachts.com



43' HANS CHRISTIAN, 1978

Classic offered for sale by original owner. New teak decks (this was a \$40,000 job alone!), Awlgrippped hull, updated interior, optional larger diesel and Telstar performance keel. **\$179,000**

See at: www.marottayachts.com



45' HUNTER 450, 1998

All the amenities with two spacious staterooms, two heads, and HUGE comfortable salon. Transferable Sausalito Yacht Harbor slip. **\$169,500**

See at: www.marottayachts.com



38' HUNTER, 2006 Very well equipped (upgraded 40 hp diesel, full electronics, offshore dodger, heavy-duty sails including in-mast furling main, electric windlass, etc.) and in great condition. Transferable Sausalito Yacht Harbor slip. **\$161,000**

See at: www.marottayachts.com



38' HANS CHRISTIAN, 1984

Great shape and extensively updated, epoxy barrier coated bottom, stunning professionally maintained brightwork, low time on Yanmar diesel, heavy duty offshore dodger, much more. **\$134,900**

See at: www.marottayachts.com



48' C&C LANDFALL PILOTHOUSE CUTTER, 1980

Spacious raised salon performance cruiser that's competitively priced and lying in a transferable Sausalito slip. **\$129,500**

See at: www.marottayachts.com



50' GULFSTAR KETCH 1977

Extensively refit for a cruise that was never taken – new sails, rigging, electronics, stainless steel ports, hatches, refinished interior, etc., etc. **\$125,000**

See at: www.marottayachts.com



37' HUNTER 376, 1999

Very spacious, light and airy, this vessel shows as new; must see to appreciate. Out-of-country owners motivated; offers encouraged. Sausalito Yacht Harbor slip can be arranged. **\$99,000**

See at: www.marottayachts.com



38' HANS CHRISTIAN, 1979

Shows well inside and out with the Burmese teak interior in particular showing beautifully. Hull recently buffed and waxed. Teak decks in fine shape as well. **\$99,000**

See at: www.marottayachts.com



41' MORGAN OUT ISLAND, 1979

Center cockpit ketch. Never cruised and fresh water kept, she shows much newer than actual age. Note all new stainless steel ports. **\$79,000**

See at: www.marottayachts.com



43' BENETEAU, 1989

Most competitively priced Beneteau of this size on the market. **\$70,000**

See at: www.marottayachts.com



38' INGRID, 1984

Clean, never cruised one owner example with low time on diesel engine (only 155 hours), custom finished interior, much more. **\$69,500**

at 100 BAY STREET · SAUSALITO · CALIFORNIA since 1946

of Sausalito

experience and knowledge to the Marotta team!



Brokers of Fine Sail and Motor Yachts

See at: www.marottayachts.com



35' BABA, 1979 Traditional double-ender with a recently varnished interior. She also sails well and will make a perfect cruising yacht for someone who wishes to sail places with grace and style. Transferable Sausalito Yacht Harbor slip. **\$69,500**

See at: www.marottayachts.com



34' SUNSET SLOOP, 1967
This full keeled jewel was built like a piano by Al Silva shortly after he left Stone Boat Yard. Fully restored; everything's done to showboat standards. **\$69,500**

See at: www.marottayachts.com



34' HANS CHRISTIAN CUTTER, 1978
Robert Perry-designed classic cutter. Capable offshore boat: full keel, high ballast-to-weight ratio, deep cockpit and big rudder placed far aft. Great shape, transferable Sausalito YH slip. **\$69,000**

See at: www.marottayachts.com



30' NONSUCH ULTRA, 1987
Professionally maintained, the interior is flawless and the exterior comes close. Transferable Sausalito Yacht Harbor slip that has a great views. A nice, must-see package. **\$59,000**

See at: www.marottayachts.com



34' VINDO, 1983 Vindo is listed in Ferenc Mate's *The World's Best Sailboats*, and this lovely example of Swedish craftsmanship shows why: the mahogany joinery below is exquisite. Transferable Sausalito Yacht Harbor slip. **\$59,000**

See at: www.marottayachts.com



40' CHALLENGER KETCH, 1973
Recently Awlgripped in beautiful Flag Blue, incredibly spacious below with 6'5" headroom. **\$55,900**

See at: www.marottayachts.com



20' PACIFIC SEACRAFT FLICKA, 1985
Factory built and finished to Pacific Seacraft's exacting standards, then updated stem to stern, including new Yanmar diesel. Shows Bristol. **\$43,500**

See at: www.marottayachts.com



32' TARGA, 1978
\$50,000 worth of improvements over the last six years – new engine, sail drive, sails, standing rigging, thru-hull sea cocks, fuel tanks, prop, electronics, dinghy & outboard. **\$34,500**

See at: www.marottayachts.com



36' ISLANDER, 1978
Extensively refit over the past five years – engine rebuilt, new sails, roller furler, electronics, etc., etc., etc. – and shows very nicely, transferable Sausalito Yacht Harbor slip. **\$32,000**

See at: www.marottayachts.com



32' DREADNAUGHT, 1978
Stout double-ender that will go anywhere in safety and comfort, with all the charm in the world! In very nice shape and lying in a transferable Sausalito Yacht Harbor slip. **\$29,000**

See at: www.marottayachts.com



30' LANCER, 1980
Refit stem to stern, unquestionably the nicest boat on the market. **\$28,500**

See at: www.marottayachts.com



30' TARTAN, 1978
Classic S&S design has been extensively refit over the years with \$30,000 spent in 2000 alone. Transferable Sausalito Yacht Harbor slip. **\$22,500**

(415) 331-6200 • info@marottayachts.com



Flying Cloud Yachts



Hans Christian



Sail • BROKERS • Power

MEMBER
Boat Wizard
M-L-S
YACHTWORLD.COM

6400 Marina Drive
Long Beach, CA 90803

www.yachtworld.com/fcyachts
flyingcloud@verizon.net

Phone (562) 594-9716
Fax (562) 594-0710

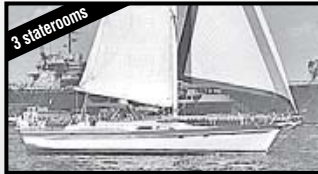

3 staterooms
54' IRWIN CUTTER, '88 \$220,000



MAKE OFFER
47' GILS CATAMARAN, '02 \$395,000



REDUCED
44' GULFSTAR CC SLOOP \$94,500



MAKE OFFER
44' HARDIN KETCH, '78 \$119,000



MAKE OFFER
HANS CHRISTIAN 43T ketch \$165,000



REDUCED
43' SPINDRIFT PH CTR, '81 \$79,900



REDUCED
48' MARINER, '81 \$145,000



REDUCED
40' CATALINA 400 MkII, '02 \$179,000



BRISTOL
42' HUNTER PASSAGE CC, '00 \$159,500



REDUCED
57' BOWMAN, '78 \$199,000



REDUCED
NEW GEMINI 105Mc, '09 \$162,500



2 available
42' CATALINAS '89 & '93

APPROX. 100 LISTINGS ON OUR WEB SITE: www.flyingcloudyachts.com

Randall Burg

YACHT AND SHIP, INC.

info@rbyachts.com

www.rbyachts.com

Richmond (510) 232-1490

Marina del Rey (310) 574-9449

Newport Beach (877) 297-3831

San Diego (858) 208-8888

◆ BANG FOR THE BUCK ◆



45' EXPLORER, 1978. Robustly built. Spacious below and well maintained. Yanmar diesel. Excellent condition. Great value at \$109,000.



55' CAMPER & NICHOLSON, 1971. Beautiful center cockpit classic. Solid pedigree w/long equipment list. Ocean ready at only \$269,000.

YOUR SHOPPING LIST: START HERE

SIZE	TYPE	LOCATION	PRICE
84'	DON BROOKE STEEL MOTORSAILER	MARINA DEL REY	\$1,400,000
80'	COOPER QUEENSHIP MOTOR YACHT, '91	DELTA	\$695,000
60'	CUSTOM HOUSEBOAT, '78	SAUSALITO	\$295,000
57'	NORTHERN MARINE TRAWLER, '04	ANACORTES	\$1,650,000
53'	BLUEWATER, '80	SACRAMENTO	\$116,500
50'	GULFSTAR CC, '79	SAN RAFAEL	\$124,000
50'	CSK CAT, '70	BERKELEY	\$99,500
48'	DEFEVER TRI-CABIN, '80	EMERYVILLE	\$185,000
47'	BENETEAU 473, 3-stateroom, '06	SAN DIEGO	\$299,000
47'	VAGABOND, excellent liveaboard, '81	ALAMEDA	\$145,000
46'	HUNTER 460, '00	SAN PEDRO	\$217,500
45'	MORGAN by CATALINA center cockpit, '92	SAN DIEGO	\$159,000
43'	PETERSON SERENDIPITY, '81	SANTA CRUZ	\$76,500
43'	GRAND MARINER, excellent liveaboard, '70	OAKLAND	\$57,000
42'	MARINE TRADER TRAWLER	DELTA	INQUIRE
42'	NOVA SUNDECK TRAWLER, 'Bristol', '87	STOCKTON	\$137,500
41'	HUNTER, '04	SAN DIEGO	\$150,000
41'	HUNTER AC, standard interior, '04	SAN DIEGO	\$165,000
36'	HUNTER 386, '04	SAN RAFAEL	\$149,000
35'	FUJI KETCH, excellent cruiser, '76	SAUSALITO	\$44,900
31'	HUNTER, '00	MARINA DEL REY	\$52,900
24'	SKAGIT ORCA COMMERCIAL, new diesel, '00	RICHMOND	\$60,000

\$50,000,000 IN PRE-OWNED BOATS

Bob Craven Yacht Sales

"MAYAN"
59' Alden
Schooner



59'	Alden Schooner 1947/2005.....	\$900,000
42'	Catalina 42 Tri-Cabin 1989.....	\$115,000
40'	Fast 40 1980.....	\$15,000
39'	Azimut Flybridge 2000.....	\$229,000
38'	C&C 110 2004.....	\$169,000
34'	CHB Tri-Cabin 1980.....	\$35,000
33'	Bertram 33 1983.....	\$39,900
32'	BHM Lobster Yacht 1994.....	\$112,000
32'	Gaff Rigged Sloop 1939/2002.....	\$48,500
32'	Luhrs Sport Fisher 1969.....	\$24,000
28'	Alerion Express 28 2005.....	\$90,000
24'	Sea Pro CC 2005.....	\$40,000
22'	Mastercraft X-Star 2004.....	\$44,500

Santa Barbara, CA (805) 689-9864

www.cravensells.com

NORPAC YACHTS

1150 Brickyard Cove Rd., B9, Pt. Richmond, CA 94801
(510) 232-7200 • FAX (510) 232-7202
email: info@norpacyachts.com

**BEST SEASON OF THE YEAR!
LIST YOUR BOAT NOW: WE HAVE BUYERS!**

**FOR MORE
SEE OUR
norpacyachts.com
WEBSITE**



35' COLUMBIA SLOOP. Very nice and highly desirable "10.7" design. Dsl, full galley, shower, wheel, dodger, bimini, RADAR, AP, Teak and Holly sole & MORE! Cruise equipped and well maintained and upgraded. Asking **\$30,950**



30' BRISTOL 29.9 Sloop. Capable & well loved pocket cruiser in beautiful shape. Furling, dsl, glass, radar, (new in '08), dodger, full cover, lavish teak below & tastefully accented above. Unusually nice boat promising years of fun & adventure. Ask **\$23,950**



32' ARIES. Ocean cruising sloop. Highly respected double-ender by Tom Gilmer. Glass, beautiful TEAK appointments. Extra nice and loaded for cruising: RADAR, furling, self-tailing winches, vane, dodger, dinghy, diesel. Ready to cruise. Asking **\$36,950**



58' ALDEN BOOTHBAY MOTORSAILER center cockpit ketch. Dsl, genset, air/heat, new upholstery, much recent refitting & refinishing. Loaded w/cruise gear, AP, radar ++. Great comfortable bluewater cruising w/excellent layout & more! Ask **\$268,950**



35' PRIVATEER BERMUDA KETCH
Lovely Gillmer design in glass w/diesel, furling, full galley, wheel, marine head and shower, ship's table/settee. Great accommodations. Many upgrades and MUCH MORE! Cruise/live in style and comfort. Asking **\$33,950**



49' CUSTOM Cold-Molded Ketch by Reliant. Beautiful Hankerson design. Powerful and seaworthy blue water cruiser in great shape. Built '91. Yanmar diesel, furling, self-tailers, aux. genset, full galley, full electronics and MORE! MUST BE SEEN. Ask **\$124,750**



47' GARDEN PORPOISE Ketch. Copper-ripped TEAK by Fung (The Best!). Cruise equipped, RADAR, etc. Big sail inventory and lots of gear. Much upgrading, some deferred maintenance (mostly cosmetic). This vessel is an Excellent Buy! **\$64,750/offers**



40' X-YACHTS X-119 SLOOP. Famous Danish builder, Racer-Cruiser one design by Neils Jeppesen. Loaded with gear, radar, New Volvo Penta diesel in 2000 and MORE! Proven ocean winner in Melbourne-Osaka Race. Asking **\$109,000**



39' FREYA, STRONG STEEL DOUBLE-ENDED CRUISER. Diesel, dink and outboard. New paint, solar, furling, RADAR, AP, cruise equipped, comfortable, well appointed. A world-class cruiser and MORE! Asking **\$48,950**



24' BENEteau FIRST 23.5 w/many upgrades: New rig by Easom, new Honda 9.9, new North 100% jib on furler & MORE! (Trailer avail. @ negotiable extra). Super fun weekender/racer. EXCELLENT CONDITION! Asking **\$13,950**



40' CHALLENGER Ketch. Gorgeous, Sparking Performance Cruiser in excellent condition. Dsl, furling, spinn., full galley, encl. head & shower, hardwood interior, wheel, pedestal, full lifelines & pulpits, inverter, Avon & o/b. MUCH MORE! Shows pride of ownership. Asking **\$55,950**



65' CLASSIC, '31 MOTORYACHT BY WHEELER. 16' beam, recent 40k hull refurb. She's ready for you to finish restoration. 3 dbl stms, pilothouse, twins, 3 heads, huge salon, crew's quarters, more. Trades considered. Asking **\$29,950**



32' WESTSAIL. Double-ended bluewater cruiser. Cruise/live ready. Diesel, vane, great sail inventory. Mexico veteran. Self-tailing winches, dodger. Exceptional boat. Strong, seaworthy and FUN! BAJA HA-HA anyone? Asking **\$48,500**



48' DUTCH CANAL BARGE by DeVries. STEEL. Unique cruising liveboard for Bay and Delta. Comfort and character. Diesel, tub, galley, fireplace, salon, convertible aft enclosure, beautiful decor, plus MORE! Asking **\$219,000**

SAIL
100' MEGA SLOOP Custom Offshore Performance Cruiser. Comfort & luxury, spacious, sleeps 17, loaded and near new. GREAT CHARTER POTENTIAL!!!... Asking 975,000
48' C & C PERFORMANCE Cruising Sloop. Beautiful & loaded. Great Saualito berth174,950/offers
43' STEEL Custom Cutter. Built by Bechtel Corp. for Pan Am Airlines. An exquisite canoe-stern, center cockpit gem. Just refit & BEAUTIFUL. Aft S/R, wheel, breathtaking..... Asking 78,950
42' Sparkman & Stephens Performance Cruising Sloop. Diesel, dodger, F/G, many upgrades & new rig Asking 41,950
40' TRIMARAN by Piver. Ketch, dsl, fast, nice, clean. Insures as F/G..... Asking 33,900
38' INGRID Ketch by Atkins. Great extra STOUT BLUE WATER CRUISER. Glass double-ender, refit & upgraded, vane, diesel, furling, RADAR & MORE!..... Asking 51,950
38' CLASSIC English Ketch by Reg Freeman. Breathtaking beauty..... Asking 124,950
37' GULFSTAR Center Cockpit Slp. Dsl, dodger, aft S/R & MORE. THIS VESSEL MUST BE SOLD NOW! REPO!..... Ask: 29,950/Make Offers
33+ ROYAL HUISMAN ALUMINUM Cutter by Alan Gurney: World class builder and designer. Yanmar diesel, new standing rig, nav station, liferaft & MORE!..... Asking 38,500
30' STEEL SPRAY Replica by Bruce Roberts. This is a NEW BOAT, never launched. Joshua Slocum's famous Spray design w/diesel, spars, sails & more! Exterior looks ready to launch. Interior started, but not finished. AHoy BARGAIN HUNTERS!!! This looks like a good one..... Asking only 14,900
30' SAGITTA Sloop. F/G, diesel, fine Danish double-ender..... Reduced..... Asking 11,950
30' CATALINA Slp. Dsl, wheel, nice. 22,000
29' PEARSON TRITON. Diesel, much refitting recently done, some left to do, very nice pocket cruiser..... 15,950/offers
29' CAL Sloop. Spinnaker, 3 jibs, main, fresh rebuild A-4 inboard, sleeps 6, AP, head, galley with oven, settee ++. Just a really nice boat..... 8,500/offers
28' HERRESHOFF H-28 ketch with brand NEW YANMAR diesel. Very nice condition and a bargain at Asking 8,950
27' CAL 2-27 Sloop. Extra nice. Inboard. Good starter boat..... REDUCED TO 4,750

POWER
130' CAMCRAFT Passenger Ship. Certified for 33 passengers overnight. Booked for the season. Virtual turnkey: Money and opportunity, working PNW 2,200,000
100' Steel HIGH ENDURANCE ADVENTURE/CHARTER SHIP in Panama. Turnkey operation. A great opportunity! MOTIVATED! Asking 1,500,000
62' TRUMPY Classic 1946 Ocean Cruising Yacht. Gorgeous interior and super comfortable layout. Exterior refinish/restore due. Economical twin 4-71s ++. OFFERS ENCOURAGED..... Asking 149,500

62' ELCO 1929 CLASSIC Twin diesel, beautiful yachting in the classic Gatsby style Asking 129,500
50' TRUMPY TRAWLER, Long range, great layout, 671 N-Series diesel. Needs TLC. A great boat! 44,950/offers
49' CLASSIC 1928 STEPHENS Raised Deck Express Cruiser. Twin 671 dsls, much recent prof. upgrading, fire damaged aft cockpit. Great opportunity... 24,950/offers
45' STEPHENS 1929 classic. Beautiful Gatsby-era motoryacht waiting to transport you back to the days of yachting in the grand style..... Try 75,000
43' CLASSIC CALLIS 1923 Custom Express Cruiser. All TEAK, famous and an exquisite head turner..... Asking 695,000
43' MATTHEWS, '65, diesel. A gem! Loaded and beautiful..... Asking 69,450
42' GRAND BANKS Twl. Aft cabin, F/B, Onan, twin dsls, radar. Excellent..... 121,000
41' CHRIS CRAFT Const. Twins, aft S/R, bridge up and more. A good cruiser or liveboard..... 13,950/offers
34' CLASSIC LAKE UNION DREAMBOAT, 1928. Dsl, full aft convert, enclosure and much more!..... A BARGAIN @ 17,500 Asking



34' DUFOUR sloop. Diesel, enclosed head and shower. Full galley, spinnaker, nav. station, wheel steering. TEAK and holly sole and more. Excellent performer with quality construction and lots of room (6'6"+headroom). Asking **\$24,950**



39' SANTANA by Gary Mull & W.D. Schock. Great designer & builder. Exceptional cond. Perfectly set up for cruising. Strong, seaworthy & comfortable. Wheel, dodger, radar, VHF, GPS, AP, depth, spinnaker, etc. VERY NICE! Ask **\$55,500**



39' CAMCRAFT Passenger Ship. Certified for 33 passengers overnight. Booked for the season. Virtual turnkey: Money and opportunity, working PNW 2,200,000
100' Steel HIGH ENDURANCE ADVENTURE/CHARTER SHIP in Panama. Turnkey operation. A great opportunity! MOTIVATED! Asking 1,500,000
62' TRUMPY Classic 1946 Ocean Cruising Yacht. Gorgeous interior and super comfortable layout. Exterior refinish/restore due. Economical twin 4-71s ++. OFFERS ENCOURAGED..... Asking 149,500

**CALL (510) 232-7200 OR FREE (877) 444-5087
OR CALL GLENN DIRECT AT (415) 637-1181
FOR INFORMATION & INSPECTION APPOINTMENTS**



KKMI **KEEFE**
KAPLAN
MARITIME, INC.

Your Complete Maritime
Service Center

FREE HAULOUTS

with Bottom Painting Packages, the price we quote is the price you pay!

5 Big Boat Series division champions had their boats readied at KKMI. We're proud to share a small part in their success! Hats off to Vincitore, Soozal, Gone with the Wind, Golden Moon & Diablita!

FINISH PAINTING FIBERGLASS ELECTRICAL

Sailing out of the Richmond area, KKMI presents to me a total solution for storage, maintenance, and any repair work for Soozal. When a solution for a boat modification or electrical issue was needed, not only was KKMI able to take on the task, but did so in a very professional manner to a high quality standard that we expect for the Soozal program. The staff has always been courteous and helpful in every way, and never did we have an issue with meeting haul or launch dates. KKMI definitely has played an important role in Soozal's success.

Daniel C. Woolery, King 40 "Soozal"

**UNBEATABLE VALUE
CONTACT US TODAY**
530 West Cutting Blvd.
Pt. Richmond, CA 94804
Office Ph (510) 235-5564
Chandlery (510) 237-4141
email us yard@kkmi.com
www.KKMI.com