

Latitude 38

Latitude 38

VOLUME 380 February 2009

WE GO WHERE THE WIND BLOWS



FEBRUARY 2009

VOLUME 380

Grand Marina

*The perfect place to entertain
the object of your affections.*

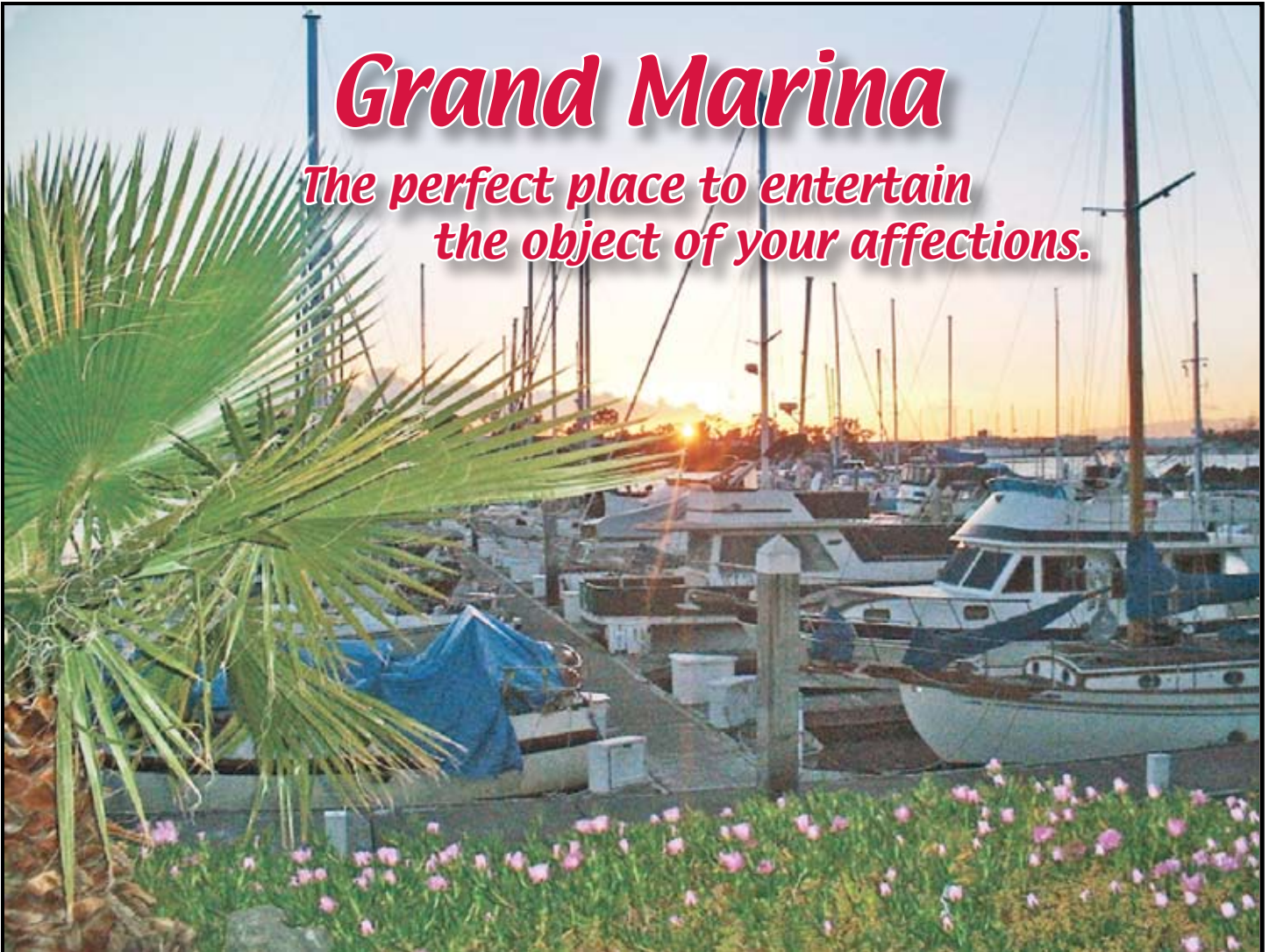

*Come by this Valentine's Day and check out our sweet deals.
You're sure to fall in love!*

*We also have a full service marine center that houses
some of the finest services available. Now that's amore!*

- Over 400 concrete berths 30 to 60 feet
- Secured Gatehouses (electronic key system)
- Dockside Electrical (up to 50A - 220V)
- Cable TV & Telephone Service
- Heated & tiled restrooms with individual showers
- Beautifully Landscaped
- Ample Parking available
- Sailboat & Powerboat Brokers on site
- Excellent customer service
- Monthly informative newsletter

DIRECTORY of GRAND MARINA TENANTS

Bay Marine Diesel.....	180
The Boat Yard at Grand Marina..	13
Lee Sails.....	178
Pacific Coast Canvas.....	65
Pacific Yacht Imports.....	11
Rooster Sails.....	72
UK-Halsey Sailmakers	36



GRAND MARINA
ANDERSON-ENCINAL

510-865-1200

Leasing Office Open Daily
2099 Grand Street, Alameda, CA 94501
www.grandmarina.com

Play Your Cards Right!



Last season brought successes in spades to Pineapple powered boats. Racers and cruisers alike found that dealing with Pineapple Sails brings results: sails that perform and endure.

This season offers new opportunities for mastering the many techniques of sailing. New Pineapple sails and the advice and service that go with them stack the deck in your favor.

Don't gamble. Give us a call today.

YOUR DEALER FOR: Musto foul weather gear, Dubarry footwear and Headfoil 2

Sails in need of repair may be dropped off at:
West Marine in Oakland, Alameda, or Richmond;
or Svendsen's in Alameda.



PINEAPPLE SAILS

Phone (510) 522-2200

Fax (510) 522-7700

www.pineapplesails.com

2526 Blanding Ave., Alameda, California 94501

*Powered by Pineapples

PUSSER'S®

*"The single malt of rum™
and the father of grog"*



Forbes writes, "Pusser's is still made in the same way it was at the time of Trafalgar - in wooden pot-stills as opposed to modern industrial column-stills. This results in the most full-flavored rum available anywhere".



The original Navy Rum and the father of grog as the rum of the Royal Navy and Royal Marines for more than two centuries.



*Gold Medals, London, 2001
San Francisco, 2003 & 2005*



Pusser's isn't for everyone. Some people prefer rums that are almost flavorless when compared to the intensely rich flavor of Pusser's. But if you want a rum that you can enjoy sipping, or still taste through the mix of your favorite cocktail, then Pusser's is for you. Try a Pusser's and Cola sometime and taste the difference.

Pusser's is not always easy to find but your local retailer can order it for you. Or take a look at HOW TO FIND IT on our web site at

www.pussers.com

Charles Tobias

Charles Tobias, Chairman

IMPORTED BY SHAW-ROSS INT'L IMPORTERS, MIAMI, FL. PUSSER'S RUM 42% ALC/VOL.

CONTENTS

subscriptions	6
calendar	8
letters	20
loose lips	74
sightings	78
<i>timella</i> rescue	98
cyc midwinters	102
eye on the bay	108
balclutha redux	114
johnston atoll	116
harbormasters	120
<i>isobar</i>	124
max ebb: twisted logic	130
the racing sheet	136
world of chartering	146
changes in latitudes	152
classy classifieds	170
advertisers' index	177
brokerage	181

Cover: *How to put a smile on your lady's face.*

Photo: Peter Lyons/www.lyonsimaging.com

Copyright 2009 Latitude 38 Publishing Co., Inc.

Latitude 38 welcomes editorial contributions in the form of stories, anecdotes, photographs—anything but poems, please; we gotta draw the line somewhere. Articles with the best chance at publication must 1) pertain to a West Coast or universal sailing audience, 2) be accompanied by a variety of pertinent, in-focus digital images (preferable) or color or black and white prints with identification of all boats, situations and people therein; and 3) be legible. These days, we prefer to receive both text and photos electronically, but if you send by mail, anything you want back must be accompanied by a self-addressed, stamped envelope. **Submissions not accompanied by an SASE will not be returned.** We also advise that you not send original photographs or negatives unless we specifically request them; copies will work just fine. Notification time varies with our workload, but generally runs four to six weeks. Please don't contact us before then by phone or mail. Send all submissions to editorial@latitude38.com, or mail to Latitude 38 editorial department, 15 Locust Ave., Mill Valley, CA 94941. For more specific information, request writers' guidelines from the above address or see www.latitude38.com/writers.html.

Affordable Options for Sailing in 2009



Introducing the new Island Packet Estero

The Estero is destined to change the perception of the mid-thirty foot range of cruising yachts. An innovative interior layout delivers more space, storage and livability than many 40-footers. The fully roller furling and self-tending scoop rig provides great performance with simple controls, making sailing easier and more enjoyable than ever. The Estero's hull design continues the evolution of the Full Foil Keel, providing a combination of benefits unmatched by any other keel configuration.

Save 10% on the introductory baseboat price of \$298,000
(available on the first 10 boats only in the U.S.)

LOA: 36'5" LWL: 31'5" Beam: 12'4" Disp: 17,800 lbs.



BENETEAU 31



BENETEAU 34



BENETEAU 37



ALERION EXPRESS 28



February Events

February 8:
VIP Sailing Day
Come sail with us
on our monthly sails!

February 19-22:
Yacht Fest at Marina Village
See over 100 used and new boats,
seminars, marine exhibits, food and fun!



February 19-22

- Power & Sail
- New & Used
- 100+ Yachts For Sale
- Seminars
- Marine Exhibits
- Music & Food



JEANNEAU 39 DS, 2007...\$195,000



SABRE 386, 2005...\$315,000



BENETEAU 473...3 from \$259,000



BENETEAU 370, 1991...\$68,800



BENETEAU 423, 2003...\$189,000



BENETEAU IDYLLE 37...\$52,000



TARTAN 44, 1975...\$79,000



ISLAND PACKET 370, 2004...\$299,000

EXPLORER 45, '79.....\$130,000
BARNETT 42 CUSTOM, '86 .. 135,000
TAYANA VANCOUVER 42, '79 . 79,500
SUNNFJORD 42, '81 (power) 118,500

TARTAN 4100, '01 275,000
CASCADE 41, '71 59,500
J/41, '85 66,000
CARROLL MARINE 1200, '95.. 89,000

BENETEAU 393..... 179,900
JEANNEAU 39 DS, '07..... 195,000
BENETEAU IDYLLE 37 52,000
CS 36, '84 64,900

HALLBERG RASSY 35, '74 50,000
SEA RAY 340, '06..... 174,500
TIARA 29, '98 69,900



FOR THE TIME OF YOUR LIFE

**Pt. Richmond
Office**

**Two
Locations!**

**Alameda Office
Marina Village**

1220 Brickyard Cove Rd
p: 510-236-2633
f: 510-234-0118

1070 Marina Village Pkwy
Suite 101
p: 510-864-3000
f: 510-337-0565

www.passageyachts.com ■ sales@passageyachts.com

BOAT LOANS

from



Trident Funding

*"a fresh approach from
people you can trust"*

*In Northern California call
JOAN BURLEIGH
(800) 690-7770*

*In Southern California call
JEFF LONG
MARGE BROOKSHIRE
(888) 883-8634*

*In San Diego call
MIKE LOCKARD
(619) 255-5666*

www.tridentfunding.com

SUBSCRIPTIONS

Please read form carefully before submitting.

We regret that we cannot accept foreign subscriptions. Check, money order, or credit card information must accompany request. Please allow 4-6 wks to process changes/additions, plus delivery time.

Enclosed is \$18 for one year on eBook

Check out www.latitude38.com and click on eBooks to see what we're talking about. Our eBooks are now in PDF format, easy to use with Adobe Reader



Enclosed is \$36 for one year Third Class Postage

(Delivery time 2-3 weeks; Postal Service will not forward third class, so you must make address change with us in writing.)

Enclosed is \$55 for one year First Class Postage (Delivery time 2-3 days; FPO/APO (military), Canada & Mexico subscriptions are first class only)

Third Class Renewal First Class Renewal (*current subs. only!*)

Gift Subscription – Card to read from: _____

Name _____

Address _____

City _____

State _____

Zip _____

Phone: () _____

Email: _____

CREDIT CARD INFORMATION
Min. Charge \$12

MASTERCARD

VISA

AMERICAN EXPRESS

Number: _____

Exp.: _____

csv: _____

INDIVIDUAL ISSUE ORDERS

Current issue = \$6.00 • With classy ad placed = \$5.00

Back Issues = \$7.00 (must indicate exact issue by month or vol. #)

DISTRIBUTION

We have a marine-oriented business/yacht club in California which will distribute copies of *Latitude 38*. (Please fill out your name and address and mail it to the address below. Distribution will be supplied upon approval.)

Please send me further information for distribution outside California

Business Name _____

Type of Business _____

Address _____

City _____

State _____

Zip _____

County _____

Phone Number _____

Latitude 38

"we go where the wind blows"

Publisher/Exec. Editor Richard Spindler richard@latitude38.com ext. 111
Associate Publisher John Arndt john@latitude38.com ext. 108
Managing Editor John Riise johnr@latitude38.com ext. 110
Senior Editor Andy Turpin andy@latitude38.com ext. 112
Associate Editor LaDonna Bubak ladonna@latitude38.com ext. 109
Associate Editor Rob Grant rob@latitude38.com ext. 105
Advertising Sales John Arndt john@latitude38.com ext. 108
Advertising Sales Shawn Grassman shawn@latitude38.com ext. 107
Classified Sales Mary Briggs class@latitude38.com ext. 104
General Manager Colleen Levine colleen@latitude38.com ext. 102
Production/Web Christine Weaver chris@latitude38.com ext. 103
Production/Photos Annie Bates-Winship annie@latitude38.com ext. 106
Bookkeeping Helen Nichols helen@latitude38.com ext. 101

Directions to our office press 4
Subscriptions press 1,4
Classified class@latitude38.com press 1,1
Distribution distribution@latitude38.com press 1,5
Editorial editorial@latitude38.com press 1,6
Calendar calendar@latitude38.com
Other email general@latitude38.com Website: www.latitude38.com

Please address all correspondence by person or department name

15 Locust Avenue, Mill Valley, CA 94941 • (415) 383-8200 Fax: (415) 383-5816

America's Most Popular Imported Sailboats



2009 Jeanneau 39i



2009 Jeanneau 42 Deck Salon



2009 Jeanneau 44i



2009 Jeanneau 45 Deck Salon

PRE-CRUISED SPECIALS

2005 44' Tartan 4400.....	\$499,000
2006 45' Jeanneau SO.....	\$299,000
2006 45' Hunter Center Cockpit.....	\$298,000
2007 44' Hunter Deck Salon.....	\$239,950
2002 40' Caliber LRC.....	\$229,000
2005 41' Hunter 41DS.....	\$214,995
1998 42' Beneteau 42.7 First.....	\$179,999
2007 36' Hunter.....	\$149,995
1989 39' Fair Weather Mariner.....	\$119,995
2004 36' Hunter.....	\$119,500
1991 37' Hunter Legend.....	\$74,900
1999 31' Hunter 310.....	\$49,995
2000 29' Hunter 290.....	\$49,900

Visit www.cruisingyachts.net for details.

See the
yachts at the:

**Yacht Fest
Marina Village**

Alameda, California

February 19 – 22, 2009

(See Advertisement in this Issue)



Cruising Yachts, Inc.

Alameda

888-78-YACHT

www.cruisingyachts.net

Hunter • Jeanneau • Caliber • Navigator
Used Sail and Power Yachts

4 TOP REASONS TO GET A BOAT NOW!

1. **GREAT** way to bring the family together.
2. **BEST** remedy to relieve modern stresses.
3. Adds more **ADVENTURE** to your life.
4. Smart buyers are getting **DEALS** of a lifetime!



WE WANT YOUR TRADE-INS!

1984 LM 30' Mtrslr \$69,000	2004 Jeanneau 40.3 \$199,000
2007 Catalina 309 \$92,000	1999 Hunter 410 \$149,000
1990 Hunter Vision \$39,900	2005 Hunter 41 \$208,000
1987 Ericson 32 \$39,900	2007 Hunter 41 DS \$229,500
1995 Catalina 320 \$66,000	1999 Hunter 410 \$155,000
1987 Catalina 34 \$49,900	1991 Hunter 42 \$124,000
1999 Hunter 340 \$88,500	2004 Hunter 420 \$199,500
1972 Coronado 34 \$35,000	2000 Hunter 42 \$165,000
1985 Irwin 34 \$35,000	1998 Catalina 42 \$148,000
2000 Hunter 340 \$79,900	1999 Bavaria 42 \$160,000
1989 Catalina 34 \$49,900	1991 Hunter 42 \$119,000
2002 Catalina 36 \$114,000	2003 Jeanneau 43 \$259,000
2005 Hunter 36 \$139,900	1998 Hunter 430 \$157,000
2006 Catalina 36 \$160,000	2002 Jeanneau 43 \$235,000
1986 Catalina 36 \$49,900	2006 Hunter 44 \$249,000
2002 Catalina 36 \$119,500	1997 Hunter 450 \$179,000
2001 Bavaria 37 \$140,000	2006 Hunter 456 \$299,500
1999 Island kt 380 \$235,000	2008 Hunter 45 \$295,000
1994 Catalina 38 \$119,000	2000 Jeanneau 45.2 \$229,000
1969 Hughes 38 \$29,800	2004 Hunter 466 \$249,000
2003 Hunter 386 \$127,250	2002 Hunter 466 \$249,900
1990 C&C 37+ \$110,000	2003 Hunter 456 \$249,500
1994 Beneteau \$124,500	2001 Beneteau 47 \$259,900
2004 Catalina 400 \$210,000	2007 Beneteau 49 \$432,900
2000 Jeanneau 40 \$149,000	2005 Jeanneau 49 \$419,000

888.325.4353
HSyacht.com
 Open 7 Days/Week



CALENDAR

Non-Race

Feb. 1-22 — Free sailing at Pier 40 every Sunday courtesy of BAADS. Info, (415) 281-0212 or www.baads.org.

Feb. 3-Apr. 27 — Sailing Skills & Seamanship course by USCGA Flotilla 12 at Sausalito Cruising Club, 7:30-9:30 p.m. \$75 fee. Info, (415) 924-3739 or margritkeyes@sbcglobal.net.

Feb. 4-25 — Wednesday Yachting Luncheon Series at St. Francis YC, 12-2 p.m., \$13.50. Enjoy lunch and a dynamic speaker every Wednesday. All YCs' members welcome. More info under the 'Events' tab at www.stfyj.com.

Feb. 6, 1777 — Britain okays privateering, the then-PC term for 'piracy', against her rebellious colonies across the Pond.

Feb. 7 — 20th Annual Southern California Yachting Association Women's Sailing Convention at Bahia Corinthian YC, Corona del Mar. Info, www.scya.org or hine@scya.org.

February, 1979 — From the first *Loose Lips* column:

This is the first time we've done this column, and it may be the last. We're trying it because previously we had no place to put some juicy little items that we'd heard. For example, where could we have told you that yacht designer Doug Peterson's 36-ft racer, *Magic Pudding*, burned at the San Diego YC? The boat was badly damaged — the fire department gave a figure of \$10,000, which shows you how much San Diego firemen know about the price of boats.

We also make mistakes that our readers would like corrected and we needed a place to do that. For example, Fred Sampson at Bill Lee's shop in Soquel would like you to know that Bill Lee did not lose a \$2,500 bet to Fred Preiss, owner of *Christine*, when *Merlin* lost in the Cal Coastal Race. But Fred would not deny that Bill Neimi, who chartered *Merlin* for that race, lost the money.

January 3, 1979, a field mouse was spotted sprinting across the floor of St. Francis YC.

Over at Pier 39 in San Francisco, it looks like they're printing money. In issues past, we remarked how unfair it was for Pier 39 to require tenants to erect Christmas lights for their boats the day after Thanksgiving — the penalty for non-compliance was stated as ejection from the marina. We have not heard of anyone who was thrown out of the marina for not displaying the decorative lights — and about 25% of the boats didn't. We still think this rule stinks, but do allow that the lighted boats were a festive sight. Another Pier 39 'rule' was that boats be 'used' so many times per month to keep diners' scenery active — as yet there is no word how this idea is, or is not, working out.

While at the Pier 39 booth at the Cow Palace Boat Show, we were surprised to hear that not all of the berths have been filled. At the start of the show, Pier 39 still had 30- and 40-ft berths open. As we recall, they went for about \$2.75 per foot, so if you're interested, give the harbor master there a call. Apparently a number of the people who originally signed up decided not to take berths. One problem has been that the rubber tire breakwater seems ineffective in keeping the groundswells out of the marina. During high winds, boats have been slamming their pulpits on the docks and fraying docklines. Even in lighter weather, the surge has been a problem, and some boats near the restaurants had to be moved to a more distant location because lunch and dinner patrons became seasick with the swaying of the masts.

Feb. 7 — Learn to Splice free seminar at San Carlos West Marine, 12 p.m. Info, (650) 593-2070.

Feb. 7 — Open House aboard *Bosun*, a 50-ft boat restored by Sea Scouts, at San Leandro Marina's Q dock, 10:30 a.m.-4 p.m. Find out more on the Sea Scouts at www.seascout.org.

Feb. 10 — Howl at the full moon on a Tuesday night.



Catalina // *Yachts*



F A R A L L O N E

Finalize Your Dream...



Northern CA Yacht Fest
Feb. 19-22 **Marina Village**



We're Introducing the NEW 29' *Ranger Tug*



San Diego Trawler Fest
Feb. 26 - 28 **Kona Kai Resort**

New Catalina's In Stock



Worlds Largest Catalina Yacht Dealer!

Preowned Catalina Yachts

Catalina 440	2005	\$331,900
Catalina 42	2005	\$225,000
Catalina 400	1999	Coming Soon
Catalina 380	1998	\$127,000
Catalina 38	1982	\$49,000
Catalina 36	1987	\$63,900
Catalina 36	1990	\$75,900
Catalina 36	2003	\$139,900
Catalina 36	2003	\$119,900
Catalina 36	2000	\$100,000
Catalina 36	1989	\$59,000
Catalina 350	2004	\$149,000
Catalina 350	2003	\$124,900
Catalina 34	1989	\$57,500
Catalina 320	2006	\$120,000
Catalina 320	2000	\$88,000
Catalina 320	1997	\$74,500
Catalina 320	1998	\$74,000
Catalina 320	1996	\$78,000
Catalina 320	1999	\$75,000
Catalina 30	1983	\$18,500
Catalina 30	1984	\$26,500
Capri 26	1993	\$33,000

Preowned Sailing Yachts

Mikelson 50	1988	\$275,000
Beneteau 473	2005	\$297,500
Cavalier 45	1985	\$255,000
Hunter 450	2000	\$199,000
Choate Racer 40	1979	\$39,000
Morgan 38	1979	\$57,500
Hunter 36	2004	\$130,000
Hunter Vision 36	1994	\$67,000
Islander 36	1979	\$46,000
Islander 36	1974	\$30,000
Sabre 36	1988	\$79,000
Hunter 35.5	1993	\$61,000
Hunter 260	2004	\$38,900

Preowned Power Yachts

McKinna Pilothouse 57	2001	\$550,000
McKinna Pilothouse 57	1998	\$475,000
Mediterranean 54	2004	\$699,999
Navigator 4400	2005	\$399,950
Cranchi Atlantique 40	2003	\$327,900
Maxum SCB 41	2000	\$215,000
Mediterranean 38	1998	\$159,000
Chaparral 350	2003	\$119,000
Maxum 2600 SE	2006	\$59,000
Trojan II Meter Exps 37	1988	\$49,900

Cruising Catamaran *New Listing*

Fontaine Pajot 42	1995	\$299,000
-------------------	------	-----------

New 2009 Ranger Tugs in Stock

R25 Tug	2009	\$134,937*
R21-EC Tug	2009	\$49,937*

*base price



Strictly Sail Pacific Boat Show
April 15 - 19
Jack London Square

1070 Marina Village Pkwy.
Alameda CA 94501
510 • 523 • 6730



2353 Shelter Island Drive
San Diego CA 92106
619 • 523 • 6730

ALAMEDA • NEWPORT BEACH • SAN DIEGO
www.faralloneyachts.com

NEW LOCATION!

ERROL FLYNN MARINA & BOATYARD



PORT ANTONIO, JAMAICA



Out of the Water Storage
up to 95 feet



Full Service Marina
100 Ton Travel-lift
24 Hour Fuel
Paint Sheds
Engine and
Parts Specialists
Duty Free Zone in Marina
Protected Harbor
Depth up to 25 Feet
at Face Dock

Open Air Market
1 Min. by Foot
Downtown Nightlife
24 Hour Security
Gated Marina
Restaurant, Beach
Bar & Grille
Free Wi-Fi Always
Mega-Yacht Docking
to 600' Alongside

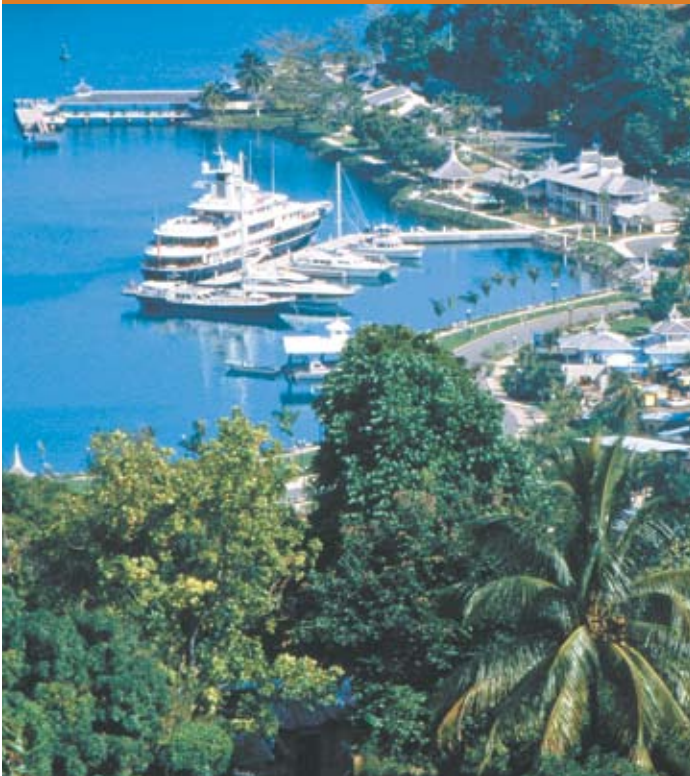

CONTACT DALE WESTIN
876-715-6044 or 876-993-3209
INFO@ERROLFLYNNMARINA.COM
VHF CHANNEL 16/9
WWW.ERROLFLYNNMARINA.COM

CALENDAR

Feb. 12 — Single sailors of all skill levels are invited to the Single Sailors Association monthly meeting at Oakland YC, 6:30 p.m. Info, www.singlesailors.org or (510) 233-1064.

Feb. 14 — Take your sweetie sailing.

Feb. 15 — Free J/24 Racing Clinic hosted by OCSC in Berkeley. Start in the classroom and move to the race course. Info, www.j24class.org/j24sf.

Feb. 15 — Triton One Design Fleet of San Francisco Sunday Lunch Cruise-In from the Estuary to South Beach Harbor for lunch at Red's Java House. Anyone interested in the classic design is welcome. Info, <http://groups.yahoo.com/group/tods/>.

Feb. 15 — Angel Island's Immigration Station Grand Re-Opening. The 'Ellis Island of the West' has been closed since 2005, undergoing a restoration. Info, www.angelisland.org.

Feb. 19-22 — Northern California Yacht Fest at Marina Village in Alameda. A winter sales event and boating celebration for the whole family. Info, www.yachtfest.blogspot.com.

Feb. 19-22 — San Francisco Ocean Film Festival celebrates the sea with films that increase awareness. \$10 per program or \$60 for a Festival Pass. Info, www.oceanfilmfest.org.

Feb. 22 — Prepare to Go Cruising Seminar by John Connolly and Modern Sailing School at Golden Gate YC, 8 a.m.-6 p.m. Reservations required. (415) 331-8250.

Feb. 22-Apr. 12 — The tallships *Lady Washington* and *Hawaiian Chieftain* will be back on the Bay for another tour. For more on daysails, mock battles and other programs, go to www.historicalseaport.org or call (800) 200-5239.

Feb. 26 — Offshore Survival seminar at Ballena Bay YC in

GRAYS HARBOR HISTORICAL SEAPORT AUTHORITY



If you missed the tallships last fall, you have another chance to sail aboard for a family daysail or mock battle.

Alameda, 7-9:30 p.m. Reservations, (510) 523-5528.

Feb. 26-28 — Trawler Fest boat show at Kona Kai Resort in San Diego. Check out the boats, seminars and a variety of other activities. Info & tickets, www.trawlerfest.com.

Feb. 28 — Marine Swap Meet at the Alameda West Marine, 7 a.m.-2 p.m. Info, (510) 521-4865.

Feb. 28 — Pre-Season Maintenance free seminar at San Carlos West Marine, 3 p.m. Info, (650) 593-2070.

Mar. 1 — Mariners' Sunday at St. Luke Presbyterian Church in San Rafael. An ecumenical service dedicated to mariners. Info, (415) 454-0758.

Mar. 7 — How the Tides Work for You presentation by Kame Richards at the Bay Model in Sausalito, 12 p.m. Space fills quickly for this popular seminar where you'll learn how to use the Bay's currents. \$15, cash only. Reservations, (408) 263-7877 or jimtantillo@comcast.net. Repeats 4/23, 7 p.m.

Mar. 11 — *Latitude 38* Spring Crew List Party at Golden Gate YC, 6-9 p.m. Earlier in the season so you can set up your

Exclusive West Coast Dealer for Tayana Yachts



TAYANA 54 DECK SALON AT OUR DOCKS



1988 FRASER 51 CUTTER
Wingstar is a Canadian-built center cockpit cutter. Great shape and ready to go again.
\$249,000



2007 TAYANA 46 PILOTHOUSE
Cruise in comfort in any climate with inside steering. With only 12 hours on Yanmar 100 hp dsl, she's virtually new. Over 1,000-mile range under power. **\$369,000**



2005 TAYANA 48 DECK SALON
Like new with only 71 hrs on Yanmar. Raymarine electronics, air/heat, genset, Corian, LeisureFurl main, electric winches. **\$489,900**



2009 TAYANA 48 DECK SALON
We have two at the factory ready to add your toys and ship. Our most popular layout at **\$430,000**



1973 BREWER 43 CC KETCH
Custom center cockpit teak ketch properly maintained by a meticulous owner.
\$69,000



1973 C&C 48 SLOOP
Great ex-racer refit at the factory with a new interior, wiring, rod rigging and Perkins MT 80.
\$179,000



2000 BENETEAU FIRST 40.7
Race ready with many upgrades like larger motor, oversize primary winches, carbon spin pole, professionally faired.
\$160,000



1990 TAYANA 55
Well cared for and consistently upgraded. New teak decks in 2006. New engine 2008. Lying Turkey.
\$360,000



1979 GLOBE 46 CC KETCH
Traditional full keel center cockpit cruising ketch in great shape.
\$95,000



1978 TARTAN 30
Clean, well taken care of example of this timeless S&S design.
\$19,500



1977 VALIANT 32 CUTTER
Classic Robert Perry design. Solid, basic platform to build your cruising boat and priced accordingly.
\$34,500



1984 TAYANA V-42 aft cockpit cutter. Mast has new LPU paint, rigging & wiring. Raymarine pkg. incl. AP, radar, GPS plotter AGM batteries. Full cockpit enclosure, 3 genoas, spinn w/sock, extensive equip. list **\$149,500**

Pacific Yacht Imports

2051 Grand Street, Alameda, CA 94501

www.pacificyachtimports.net

We're at Grand Marina

Dave Wolfe • Neil Weinberg

Tel (510) 865-2541 Fax (510) 865-2369

tayana@mindspring.com

Dreaming of Cruising?



Untie Your Dream from The Dock!

Real World Cruising presents a series of lectures and hands-on workshops designed to help you turn your cruising dream into a reality.

February Workshop:

Rigging Your Boat by BRION TOSS

February 21 & 22, 9 am to 5 pm

Coral Reef Inn & Suites, Alameda
(registration required)



Brion Toss, master rigger, will be giving Real World Cruising's premier Lecture/workshop "Rigging Your Boat". Mr. Toss, popular speaker and author of many books including *The Rigger's Apprentice*, has been a rigger for more than 30 years. He has helped countless cruisers avoid the pitfalls of poorly designed and maintained rigs. Brion will demonstrate the theories that will help you choose the right gear for your boat; his workshop will teach you how to assemble, install and maintain it.



March Workshop:



Be Your Own Surveyor

by GUY STEVENS

March 28 & 29, 9 am to 5 pm

Coral Reef Inn & Suites, Alameda
(registration required)

The survey is often the final step in acquiring a boat ... after you have invested a lot of time and effort in the purchase. A more sensible solution is to survey the boat at the front-end of the process. Guy Stevens' intensive 2-day, hands-on workshop will show you what to look for, what to look out for, and what to run away from. If you already own a boat, our survey method will help you identify and prioritize needed upgrades as you prepare for cruising.

Guy Stevens has been surveying sailboats for over 15 years.

Guy and his wife Melissa have lived aboard for more than 12 years, and have over 50,000 miles of cruising experience.

Real Experience,
Real People,



To register:

510-629-6525 or

RealWorldCruising.com

CALENDAR

crew sooner! Now just \$5 for anyone 25 and under (with ID)! Still only \$7 for the rest of us. Info, www.latitude38.com.

Mar. 12-15 — Sacramento Boat Show at Cal Expo. Info, www.sumainc.com.

Apr. 15-19 — Strictly Sail Pacific, Jack London Square. As the West Coast's really big all-sailboat show, this is a must-see for sailors. Info, www.strictlysailpacific.com.

TBA, 2009 — Power Squadron Safety classes. A great way to learn the ropes! Call (408) 225-6097 for upcoming classes in Santa Clara and (415) 924-2712 for classes in Marin.

Racing

Feb. 7 — Perry Cup for Mercuries. MPYC, www.merc583.addr.com/sail/index.html.

Feb. 7-8 — BAYS C420 Winter Series #3. RYC, www.bayarea-youthsailing.com.

Feb. 21-22 — BAYS Opti Winter Series #3, EYC www.bayarea-youthsailing.com.

Feb. 28 — Island YC Sadie Hawkins Race on the Estuary. Woman skipper, full crew. Chowder challenge afterwards. John New, (510) 521-7442 or iycracing@yahoo.com.

Mar. 5-8 — Heineken Regatta, St. Maarten, West Indies. One of the world's great fun regattas — and some of the wildest parties. Ouch, my liver! Info, www.heinekenregatta.com.

Mar. 5-8 — Acura Miami Grand Prix, Premiere Racing Events. Info, www.premiere-racing.com.

Mar. 6 — Newport Beach to Cabo San Lucas Race. This 800-mile downwind dash serves as a great tune-up for the TransPac. Newport Harbor YC, www.nhyc.org.

Mar. 7-8 — Spring Keel Regatta on the Cityfront. StFYC, (415) 563-6363 or raceoffice@stfyc.com.

Mar. 8 — Coyote Point YC's Jack & Jill Race. Info, (650) 347-6730, www.stfyc.com or regatta@cpyc.com.

Mar. 14 — Island YC's Doublehanded Lightship. Proceeds benefit United Cerebral Palsy. Info, www.iyc.org.

Mar. 14-15 — Big Daddy Regatta, a don't-miss Bay Area classic. RYC, (510) 237-2821 or www.richmondyc.org.

Mar. 14-15 — Spring Dinghy Invitational & BAYS Laser Winter Series #3. StFYC, (415) 563-6363 or www.stfyc.com or www.bayarea-youthsailing.com.

Mar. 14-15 — Camellia Cup Regatta on Folsom Lake, for centerboards, multihulls and keelboats. Folsom Lake YC, www.flyc.org.

June 29-July 5 — 45th L.A. to Honolulu Race, better known as the TransPac, starts. Info, www.transpacrace.com.

Midwinter Regattas

BERKELEY YC — Midwinters: 2/14-15, 3/1 (Champion of Champions). Bobbi, (925) 939-9885.

BERKELEY YC — Chowder Races: Sundays through March except when it conflicts with above. Tom Nemeth, tom.nemeth@there.net.

CAL SAILING CLUB — Year-round Sunday morning dinghy races, intraclub only, typically in Laser Bahias and JY15s — both two-person sloops. Email Gary and Alistair at racing_chair@cal-sailing.org.

CORINTHIAN YC — Midwinters: 2/21-22. Andre Klein, racing@cyc.org.

ENCINAL YC — Jack Frost Series: 2/28, 3/28. Tom Wondolleck, rearcommadore@encinal.org.

GOLDEN GATE YC — Seaweed Soup Series: 2/7, 3/7. Gary Salvo, (916) 363-4566.

ISLAND YC — Estuary Midwinters: 2/8, 3/15. Info, www.iyc.org.

LAKE MERRITT SC — Dinghy Midwinters: 2/14, 3/8.

THE BOAT YARD AT GRAND MARINA

Formerly Mariner Boat Yard

"Where Service Has Meaning"

Interlux.
yachtpaint.com

AWLGRIP
AWLGRIP

**60-TON
TRAVELIFT**



FEATURING
TRINIDAD
ANTI-FOULING PAINT BY
PETTIT
marine paint
RATED "SUPERIOR" by
Practical Sailor

The only yard to brush on your bottom paint!

Dealers for:

MAX-PROP
AUTOMATIC FEATHERING PROPELLERS

GORI
marine

Webasto

PACKLESS SEALING SYSTEM
SHAFT SEAL

LECTRA/SAN

SIDE-POWER
Thruster systems

facnor
PURGING SYSTEMS INC.

AQUAMARINE
FINE REVERSE OSMOSIS EQUIPMENT

IT'S SIMPLE!

Call The Boat Yard at Grand Marina for the Lowest Bottom Prices!

~ COMPARE US WITH THE COMPETITION ~

- Prop and Shaft Work
- Mast & Rigging Repair
- Fiberglass & Blister Repair
- Gelcoat Repair
- Gas & Diesel Engine Service
- LPU Hull & Topside
- Electrical Repair & Installation

CALL FOR A RESERVATION

(510) 521-6100 • Fax (510) 521-3684

Located at Grand Marina • 2021 Alaska Packer Place, Alameda

www.boatyardgm.com

CALENDAR

Beth, (510) 444-5292.

OAKLAND YC — Sunday Brunch Series: 2/1, 2/15, 3/1. Sheldon, sheldon.haynie@gmail.com.

REGATTAPRO — Winter One Design: 2/14. Jeff, (415) 595-8364 or jzarwell@regattapro.com.

RICHMOND YC — Small Boat Midwinters: 2/1, 3/1. Tony, (925) 426-0686 or www.richmondyc.org.

SANTA CRUZ YC — Midwinters: 2/21, 3/21. Info, (831) 425-0690.

SAUSALITO YC — Sunday Midwinters: 2/8, 3/1. Paul, (415) 269-1973 or race@syconline.org.

SEQUOIA YC — Winter Series: 2/28, 3/14. Redwood Cup: 2/15, 3/1. Jim Peterson, (650) 793-3437 or jpeterson2008@comcast.net.

SOUTH BAY YRA — Midwinters: 2/7, 3/7. Jocelyn Reed, regatta@cpyc.com.

SOUTH BEACH YC — Island Fever Midwinters: 2/21, 3/21. Info, www.southbeachyc.org.

TIBURON YC — Midwinters: 2/7, 3/7. Info, (415) 789-9294 or pando@sonic.net.

VALLEJO YC — Tiny Robbins Midwinters: 2/7. Info, (707) 643-1254.

Mexico and Beyond

Feb. 3-8 — 8th Annual Zihua Sail Fest in Zihuatanejo, Mexico. Five days of parties, contests, potlucks, races, BBQs, auctions and chili cook-offs are what attracted more than 70 boats to last year's event, but the real payoff was raising money for local schools. These kids, many of whom are orphaned, can't attend Mexican schools until they learn to speak Spanish. Last year about \$56,000 was raised thanks in large part to matching funds raised by the Bellack Foundation and Pete Boyce. To join in the fun and help some needy kids — even if you can't make it to the parties — go to www.zihuasailfest.com.

Feb. 9 — Pacific Puddle Jump Kick-Off Party, in Zihua (exact location TBD). *Latitude 38* hosts the first of two get-togethers for South Pacific-bound cruisers. It gives everyone a chance to compare notes and finalize radio skeds, and also gives *Latitude's* Andy Turpin a chance to interview you and take your photo for the magazine. Open only to people who are Puddle Jumping this year. For details, email andy@latitude38.com or go to www.pacificpuddlejumps.com.

Feb. 12 — Pacific Puddle Jump Kick-Off Party at Vallarta YC in Nuevo Vallarta from 2-5 p.m. *Latitude 38*, Paradise Marina and the Vallarta YC team up to host the final get-together for South Pacific-bound cruisers. For details, email andy@latitude38.com or go to www.pacificpuddlejumps.com.

Mar. 17-21 — The 17th Annual Banderas Bay Regatta. Five days of 'friendly racing for cruising boats'. The sailing conditions and the Paradise Marina venue couldn't be better. Everybody plays it safe because they're sailing their homes, and the entry is free. It's the perfect time and place to have family and friends fly down to join you in the tropics. In fact, you'd have to be nuts to miss this one. The regatta is part of the month-long Festival Náutico Vallarta. For details, visit www.banderasbayregatta.com.

April 2-5 — La Paz Bay Fest. This will be the fifth year for this descendant of the (in)famous La Paz Race Week. An event for cruisers that includes races, potlucks, cruising seminars and other fun activities for the family. More info on Bay Fest 2009 will soon be found at www.clubcruceiros.org.

Apr. 30-May 3 — Loreto Fest and Cruisers' Music Festival. This classic Baja event, started to clean up Puerto Escondido, draws a very large crowd of cruisers and Baja land-travellers for a chili cook-off, dinghy races and other water activities,



ATTENTION CRUISERS! MEXICAN LIABILITY INSURANCE ONLINE

Now with six offices offering you local insurance service and global insurance coverage.

SEATTLE
Joe Cable
(800) 823-2798 • (206) 281-8144
Fax (206) 281-8036

NO. CALIFORNIA
(800) 853-6504 • (650) 373-0595
Fax (650) 548-1585
email: boomeins@aol.com
Lic. # 0A99058

L.A./ORANGE COUNTY
Craig Chamberlain
(800) 992-4443 • (949) 642-5174
Fax (949) 642-0252
Lic. # 0D36887

SAN DIEGO
Henry Medina
(800) 639-0002
Fax (619) 226-6410
Lic. # 0A96346

BRADENTON, FLORIDA
Jerry Norman
(800) 914-9928
Lic. # E051940

New!
PUERTO VALLARTA
(949) 274-4111

ASK ABOUT OUR NEW RACING SAILBOAT PROGRAM!

It's a Mariner's Fact:
A longshore current is a current paralleling the shore largely within the surf zone. It is caused by the excess water brought to the zone by the small net mass transport of wind waves. Longshore currents feed into rip currents.

Cityyachts

San Francisco's yacht broker since 1969

YACHTS AND THE CITY



42' Bertram Motor Yacht,
1981, \$169,000



28' Catalina MkII, 2002
\$62,500



28' Bayliner 2855, 2000
\$44,500



Hunter 45, 2006
\$219,000



42' Fountaine Pajot Venezia,
1995, \$199,000



36' Islander, 1975
2 from \$42,000



Sabre 34, 1983
\$54,900



Passport 40, 1985
\$114,800



Bayliner 3218, 1987
\$34,500



32' Grand Banks Sedan,
1980, \$119,000



28' Fiberform Flybridge
Cruiser, 1974, \$19,000



27' Farallon, 1982,
enclosed helm, \$35,000



37' Beneteau Oceanis 370,
1991, \$69,800



35' Niagara, 1980
\$58,500



46' Moody, 2000
\$399,000

10 MARINA BL. • SAN FRANCISCO, CA 94123 • Toll Free: 877-444-5091 • 415-567-8880
FAX (415) 567-6725 • email sales@citysf.com • website <http://yachtworld.com/cityyachts>



PLEASE VISIT OUR FUEL DOCK AT GASHOUSE COVE MARINA • OPEN 7 DAYS A WEEK • 9AM TO 5PM

North times seven.

When performance counts the choice is clear.
Call your nearest North Sails representative.

Sausalito
415-339-3000

San Rafael - Sail Care
415-453-2142

Channel Islands
805-984-8100

Marina Del Rey
310-827-8888

Long Beach
562-795-5488

Costa Mesa - Sail Care
949-645-4660

San Diego
619-224-2424



www.northsails.com

CALENDAR

the Candeleros Classic race, and lots of participant-created music. The goals are to have fun and raise lots of money for Mexican charities in Puerto Escondido and Loreto. Visit www.hiddenportyachtclub.com.

June 19-21 — Tahiti-Moorea Sailing Rendezvous, hosted by *Latitude 38* and Tahiti Tourisme. This free event is focused on cross-cultural appreciation and includes a cocktail party, a sailing rally to Moorea, Polynesian music and dance performances, and cruiser participation in traditional Tahitian sports — the highlight of which is the six-person outrigger canoe races. Info, www.pacificpuddlejumps.com.

Please send your calendar items by the 10th of the month to calendar@latitude38.com. If you're totally old-school, mail them to *Latitude 38* (Attn: Calendar), 15 Locust Avenue, Mill Valley, CA, 94941 or fax them to us at (415) 383-5816. But please, no phone-ins! Calendar listings are for marine-related events that either are free or don't cost much to attend. The Calendar is not meant to support commercial enterprises.

February Weekend Tides

date/day	time/ht. HIGH	time/ht. LOW	time/ht. HIGH	time/ht. LOW
1/31Sat	0237/5.6	0840/1.6	1445/4.3	2020/1.5
2/01Sun	0313/5.8	0942/1.3	1602/3.8	2102/2.1
2/07Sat	0248/2.9	0858/6.9	1556/-1.2	2306/5.2
2/08Sun	0344/2.5	0954/6.9	1639/-1.2	2342/5.5
2/14Sat	0237/5.9	0901/0.9	1524/4.2	2036/2.0
2/15Sun	0316/5.8	1004/0.9	1650/3.8	2126/2.6
2/16Mon	0401/5.6	1113/0.8	1838/3.7	2233/3.1
2/21Sat	0255/3.0	0843/5.7	1541/0.0	2249/4.7
2/22Sun	0335/2.7	0928/5.8	1613/0.0	2312/4.9
2/28Sat	0114/5.8	0722/0.8	1351/4.6	1911/1.6
3/01Sun	0148/5.9	0813/0.5	1455/4.2	1950/2.1

February Weekend Currents

date/day	slack	max	slack	max
1/31Sat	1100 2242	0116/2.9F 1350/2.3F	0424 1650	0725/3.4E 1941/2.7E
2/01Sun	1204 2328	0200/2.6F 1452/2.2F	0501 1806	0815/3.6E 2037/2.2E
2/07Sat	1046	0159/2.2E 1411/5.6E	0501 1808	0758/3.1F 2114/4.3F
2/08Sun	0030 1142	0250/2.7E 1501/5.7E	0555 1854	0852/3.4F 2157/4.5F
2/14Sat	1121 2310	0118/2.8F 1410/2.6F	0422 1721	0720/3.7E 1943/2.2E
2/15Sun	1226	0205/2.3F 1521/2.3F	0506 1832	0811/3.5E 2039/1.6E
2/16Mon	0007 1334	0300/1.9F 1644/2.2F	0556 1948	0908/3.3E 2145/1.2E
2/21Sat	1034	0202/1.7E 1355/4.1E	0500 1754	0753/2.3F 2102/3.3F
2/22Sun	0004 1119	0229/2.1E 1432/4.3E	0540 1828	0832/2.6F 2130/3.4F
2/28Sat	0256 1545	0605/4.0E 1827/2.9E	0936 2127	1234/2.9F
3/01Sun	1030 2206	0037/2.7F 1328/2.8F	0329 1649	0651/4.1E 1918/2.3E



Hans Christian



Flying Cloud Yachts

Sail • BROKERS • Power



6400 Marina Dr., Long Beach, CA 90803

Phone (562) 594-9716 Fax (562) 594-0710



NEW 105Mc - GEMINI, 2009
Best selling cruising catamaran in the U.S.!
\$162,500



40' CATALINA 400 MKII, 2002. In-mast furling main & headsail, 200 hrs on 50hp Yanmar, 8kw Panda dsl genset, twin wheels, full electronics. \$198,500



35' HUNTER LEGEND, 1987. Nice family boat. Low hours on Yanmar diesel, walk-through transom, new standing rig '02. \$39,500



33' HANS CHRISTIAN CUTTER, 1985. World class pocket cruiser. Exceptionally large, high quality interior. Excellent electronics. \$120,000



45' ANDREWS SLOOP, 1999
Turn key, proven offshore racer!
\$360,000



42' PEARSON KETCH, 1978. Roomy, cruise ready, aft cockpit/cabin. Pearson quality construction. Priced right. \$76,000



54' HUNTER SLOOP, 1981
New Yanmar diesel. Upgraded & equipped for cruising. Redesigned transom, keel. \$99,000



57' BOWMAN KETCH, 1978
Five hours on rebuilt 110hp Perkins. New electronics. Top-quality bluewater cruiser. \$219,000



46' ERICSON SLOOP, 1973. Flush deck, Bruce King-designed, rare C-model cruiser. 2 staterooms, large salon, Perkins diesel. \$110,000

Web site: www.yachtworld.com/fcyachts • email: flyingcloud@verizon.net



37' NAUTOR SWAN, 1971. S&S designed classic. Full LP paint, canvas for all wood, fresh interior varnish, updated 'tronics. \$80,000



40' NORTH AMERICAN SLOOP, 1979
Perkins diesel, almost everything is new, tons of upgrades! Call for details. \$55,000



40' CHOATE, 1979 New Yanmar diesel in 1997, low hours, new fuel tank, sleeps 9. Great racer or fast cruiser. \$47,500



38' CATALINA SLOOP, 1982
Original owner, consistently upgraded. New genoa, re-wired and re-plumbed. \$49,500



38' HANS CHRISTIAN, 1986 High quality Telstar underbody cutter with 50hp Westerbeke diesel. World class cruiser. \$149,500



35' ISLAND PACKET, 2001. Yanmar diesel, 2 staterooms. Ready for bluewater cruising. Only one for sale on West Coast. \$189,000



32' ERICSON, '90. Very clean/well kept; nicest brokerage sailboat on market in this size/price range. New main, jib and cruising spinnaker. \$59,000



28' CAL SLOOP, '86 Westerbeke dsl, AP, radar, refrigeration. Gennaker & tabernacle mast. Near new condition; priced for quick sale. \$29,500



27' NOR'SEA SLOOP, 1978
Center cockpit, new galvanized trailer, new Yanmar diesel, Aries windvane. \$35,000

Some boats shown may be sisterships.

Northern California **Yacht Fest**

@ Marina Village Yacht Harbor, Alameda, CA

**Winter Sales Event &
Boating Celebration
for the Whole Family!**
Free Admission & lots of Free Parking

For complete information to go www.YachtFest.BlogSpot.com

February 19-22

- Power & Sail
- New & Used
- 100+ Yachts For Sale
- Seminars
- Marine Exhibits
- Music & Food

Participating Exhibitors more to follow...



Richard Boland Yachts



Tim's Zodiac

License #0E32738

TWIN RIVERS MARINE INSURANCE

AGENCY, INC.

"Your Boat Insurance Specialists"

7 Marina Plaza • Antioch, CA 94509

At The Antioch Marina

Why Twin Rivers?

- Broad Navigational Areas
 - Liveboards
 - Mexican Liability
- Agreed Value Policies
- Shop Your Renewal



Get a quick quote today at:
www.BoatInsuranceOnly.com
 (800) 259-5701

Insurance made simple, affordable and effective.

Representing...



ace seguros



ace recreational marine insurance



LLOYD'S

Years of unbeatable experience to match your needs to the right product.

Worldwide Coverage

West Coast □ Mexico □ East Coast

Caribbean □ Pacific

LETTERS

↑↓ HOW MUCH DOES IT COST TO GO CRUISING?

I did the '08 Ha-Ha aboard Gary Burgin's SR-55 cat *Crystal Blue Persuasion*, and I'm now interested in altering my life from working every day to cruising. As you know, ignorance can be an expensive lesson, so any detailed budget information that you can glean from other cruisers would be quite valuable to me. I look forward to what cruisers have to report.

Richard Frankhuizen
Folsom

Richard — With unemployment on the rise, most investments getting clobbered and it now being a full-fledged buyer's market for boats, this is the most opportune time to go cruising we can remember in 30 years. After all, it's likely that you could take a couple of years off to go cruising, then return with a great tan and the memory of countless adventures, without having missed out on much except a lot of gloom.

The following letters are some of the responses we've received on the subject of cruising costs. As you'll read, the costs range from about \$10,000 a year to \$100,000 a year. We're not sure that the \$10,000/year cruisers have much less fun than those who spend 10 times as much.

The other thing to keep in mind is how lucky we West Coast cruisers are. Mexico is much easier for us to get to than the Caribbean is for East Coast sailors, and it's much, much less expensive than the Caribbean.

↑↓ YOU KNOW YOU'RE A CRUISER WHEN . . .

I read your request for examples of cruising budgets, and thought I'd share our experience. Our family of four — which includes my wife, Christy, and our young girls, Cassie and Juliana — have been out for 3.5 years now. We've sailed in the Bahamas, which was cheap, to the Caribbean, which was pricey, and to the Med, where the prices are psycho!

Although we don't keep exact figures — maybe we don't want to know the real cost — we probably spend an average of \$4-5,000 per month. That would include boat projects, trips home for Christmas, and so forth. We steer clear of marinas

— in fact, we haven't tied up since early November in Rabat, Morocco. But we've enjoyed tours, trips and restaurants in the variety of locations we've visited. I would consider ours to be in the middle range of cruising budgets, somewhere between the hand-to-mouth crowd and the fancy yachts with crews.



COURTESY ZIA

The Boyle Family have been enjoying a comfortable cruising style for the last 3.5 years.

We just got back to the Caribbean from the Med, and are now hanging out in the Windwards. We are looking forward to a lot more sailing and a lot less motoring than we did in the Med. Despite having crossed the Atlantic, our tanks are still full of expensive fuel we bought in Morocco — and we hope to hold on to it as long as possible. When it comes to sailing versus motoring, the Caribbean beats the Med hands down!

Joe Boyle and family
Zia, Switch 51 cat
Windward Islands

The untold story of Noah's Ark



“...and after 40 days and 40 nights of rain, the Ark floated perfectly and did not leak. Noah gave thanks and praise to Svendsen's Boat Works for a great retrofit, bottom job and sage advice whilst in the boatyard.”

Svendsen's... the oldest and most experienced boatyard on San Francisco Bay. Since 1963 A.D.



**To schedule your retrofit
and bottom job,
call 510.522.2886
or visit us at svendsens.com.**



MULTIHULLS

CORSAIR



MARINE

INTERNATIONAL



CORSAIR'S NEW 750 SPRINT

Some say, "Faster than a speeding bullet." Longer cockpit, larger sail area, taller mast, deeper daggerboard, bigger rudder, bigger bow pole. MORE FUN! Great family cruiser. Sailing should be something that feels good. **You got-a-Tri this one! For a ride, call Gary at (510) 865-2511 or Kurt at (619) 571-3513.**

When the first Corsair Trimaran blasted by every sailboat on the water in 1985, a precedent was set for a sailboat to offer the best in high performance racing and cruising on the average family budget. It must be easy – easy to sail, easy to trailer, easy to launch, easy to afford, easy to maintain, and easy on the eyes. Since the launch and take-off of the first Corsair Trimaran, Corsair Marine has exceeded every requirement of this precedent by developing new and better material combinations and construction techniques for increased performance through lighter weight, and relentlessly improving design elements for increased durability and safety, and improved aesthetics.



CORSAIR 31

Ask about the full line of Corsair multihulls: Sprint 750, 24, 28, 31, 37, 50

See pre-owned Corsairs at the Web sites below.

Northern California



314 Tideway Dr., Alameda, CA 94501
www.helmsyacht.com
(510) 865-2511

Southern California

West Coast Multihulls

1053 Rosecrans, San Diego, CA 92106
www.westcoastmultihulls.com
kurt@westcoastmultihulls.com
(619) 571-3513

LETTERS

Readers — Joe and his family have a very nice website — www.zialater.com — which has lots of great photos and information. In particular, we got a laugh out of their 'You Know You're A Cruiser When . . .' section. As in, you know you're a cruiser when: 1) People offer you food they were going to throw away — and you accept. 2) You take a shower, then put on the same clothes you were wearing before the shower. 3) A swim in a pool or a hot tub counts as a shower. 4) Your friends try to nail you down on a time and place to meet, but you just can't commit. 5) You feel proud when you serve drinks that have ice cubes."

Anybody want to add to their list?

WE AVERAGE LESS THAN \$1,300 PER MONTH

In response to your request, we just figured out our average monthly spending for cruising in '08. After five years of cruising, we've found that we're still averaging less than \$1,300/month, and that's with about six weeks a year in marinas. Here's the breakdown on a monthly basis:

- Food — \$290
- Liquor — \$55
- Berthing — \$60
- Laundry — \$14
- Fuel and Oil — \$100
- Entertainment — \$94
- Miscellaneous, but mostly medical — \$275

We hope this is helpful for anyone thinking about making the 'big break'.

Jay & Janice Hawkins, with Buster, the bad dog
Ceilidh, Pearson 40
Bahia de Los Muertos / formerly Sausalito

Jay and Janice — Thanks for your report. Based on the fact that you're still cruising after five years, we're going to presume that you find the cruising life to be as satisfying as it is economical.

CRUISING IN B.C. ISN'T SO CHEAP

What it costs to cruise each year is a good question. The one thing we've found out is that it's not cheap to winter on one's boat in British Columbia. We're paying CDN\$1,050/month for our slip in Port Sidney Marina which, at the current exchange rate is about US\$800. We paid over US\$4 for a gallon of diesel last month and, even after that, found that our diesel heater is far less expensive than the electric alternatives. That's because the marina charges CDN\$0.07 per kilowatt for electricity. Before we knew the cost, we ran up a CDN\$283 electric bill our first month here. We are now averaging about US\$200/month for fuel, versus US\$500 or more per month when we were actively cruising earlier this year. But we spent most of that time motoring up to Alaska and back.

Our food costs are about \$400 a month. It's a little unusual, however, because as a result of my medical condition, the only thing I can 'eat' are Nestlé Carnation's Very High Calorie Instant Breakfast drinks. I import these from the States, although the price recently doubled because of a corporate merger. Sharon's food, which is normal, seems a little less expensive than in the States. When the occasional outing for lunch or dinner is included, I'd guess that we spend about \$400/month on food.

Our maintenance costs have recently dropped considerably because the major system failures — twice with diesel heaters and once with our Freedom 25 Inverter/Charger — have dropped as well. But we're not down to \$0. I figure

M U L T I H U L L S

SEAWIND

since 1932



NEW SEAWIND 1160

Seawind's brand new 38-ft sailing cat, the Seawind 1160, has just been launched and is proving to be an immediate success. The new Seawind 1160 combines some of the best features of the earlier Seawind 1000 and Seawind 1200 sailing catamarans. Winner of 2005 Australian Boat of the Year.



SEAWIND 1000 XL

The Seawind 1000 is Australia's most successful cruising catamaran, with the unique combined saloon and cockpit. This model has sailed all around the globe with many offshore passages successfully sailed including through the South Pacific, Hawaii and Alaska.

47' SHUTTLEWORTH, 32' PDQ,
and more pre-owned multihulls
at the Web sites below.

Northern California



314 Tideway Dr., Alameda, CA 94501
www.helmsyacht.com
(510) 865-2511

Southern California

West Coast Multihulls

1053 Rosecrans, San Diego, CA 92106
www.westcoastmultihulls.com
kurt@westcoastmultihulls.com
(619) 571-3513

M U L T I H U L L S

Fountaine Pajot

C A T A M A R A N S

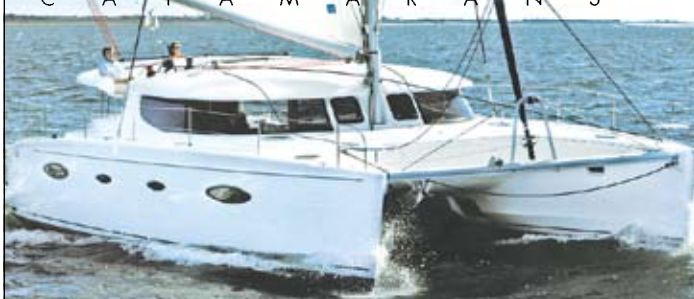

SALINA 48

Announcing Fountaine Pajot Southern California!

West Coast Multihulls is proud to represent this highly regarded, elegant line of cruising catamarans. Contact us for information about Fountaine Pajot's full line:
36 • 40 • 44 • 48 • 60 • 65



PDQ POWERCAT

West Coast Multihulls

is the California dealer for luxury cruising power catamarans. PDQ is committed to building high quality catamarans for cruising couples. Call about both the PDQ 34 and the PDQ 41.

See pre-owned and new
PDQ Catamarans
at our Web site below.

California

West Coast Multihulls

1053 Rosecrans, San Diego, CA 92106
www.westcoastmultihulls.com
kurt@westcoastmultihulls.com
(619) 571-3513

**OVER ½ MILLION \$\$
IN INVENTORY
ALL ON SALE!**

**Up To
50%
OFF**



Robin Driscoll Freedom www.lyonemaging.com

RICHARD DRESCHLER

LETTERS

we were spending over \$1,000/month for maintenance during the summer when we were traveling 40 to 50 miles every day. Since 'parking' in Sidney for the winter, that expense is down to about \$200 a month. For example, just this week I had to deal with a broken door latch, which I replaced at West Marine for about \$30, plus a faulty float switch on the bilge pump. Our insurance runs about \$185 a month.

Our other expense is mail and package forwarding, which is around \$150 per month. Then there are services to have our banking and checking deposits handled by our accountant,



Cruising British Columbia may not be cheap — or tropical — but it sure is beautiful.

another \$100 per month.

The only other significant expense is communications. Because Sharon still works at her public relations business, we have internet costs — Verizon Aircards and B X WiFi service

— of about \$150 per month. Cell phones on a global plan run another \$250/month, and the satellite phone has been averaging around \$180 per month. Throw in SailMail at \$20/month and OCENS, another \$20/month, and you'll see why communications are one of our biggest expenses.

All of the above adds up to around \$3,500/month. I haven't thrown in personal costs unrelated to cruising, but medical insurance is a big expense for us because of my personal health condition. Then there's the airfare for occasional trips that inevitably arise, and other stuff that people often forget to consider. Including everything, we spend close to \$6,000/month.

Once we get south, I believe we'll be able to cruise far less expensively, especially by anchoring out. We're currently planning to join this year's Ha-Ha, a full year ahead of our original plan. As a result, we'll have to pick *Latitude's* brain about communications, and where we should base ourselves for the '09-'10 winter in Mexico to make it possible for Sharon to continue her business. That will require good communications with her clients and reasonable airport access. *Latitude* probably faces all the same issues, so my guess is you have just the right answer and a healthy list of options.

Richard Drechsler
Last Resort, Catalina 470
Sidney, B.C. / Long Beach

Richard — We expect that you'll be able to cruise on a much smaller budget in Mexico, assuming, of course, you follow through with your plan of avoiding marinas. The best places for you to set up a base are probably La Paz, Banderas Bay, Barra de Navidad, and Zihua. You can anchor for free at all these places and they all have nearby airports. Alaska Air has great flights between California and all these areas. It's just 3 hours and 15 minutes, for example, from P.V. to San Francisco. Thanks to the two-hour time difference, we often catch the 5 p.m. flight and arrive in San Francisco with enough time to get in a couple of hours of evening work at the office. If you book carefully and far enough in advance, the flights can be very

**KKMI Special:
Trinidad Pro* (SR)
\$196.00**

**For professional application*

530 West Cutting Blvd. * Pt. Richmond, CA 94804
Office (510) 235-5564 * Chandlery (510) 237-4141
email yard@kkmi.com * visit www.kkmi.com

SAIL California

ALAMEDA
1070 Marina Village Pkwy #108
Alameda, CA 94501
(510) 523-8500
FAX (510) 522-0641

SEATTLE
SAIL NORTHWEST
7001 Seaview Ave. NW #140
Seattle, WA 98117
(206) 286-1004

JOIN US AT:

Northern California Yacht Fest



© Marina Village Yacht Harbor, Alameda, CA

February 19-22

- Power & Sail
- New & Used
- 100+ boats on display
- Seminars
- Marine Exhibits
- Music & Food



J/124, 2007
Gone Again

The J/124 offers an exquisite escape from the stress of life on land. *Gone Again* offers many upgrades. Now is the time, this could be your boat.
Asking **\$349,000**



Sabre 402, 1998
Blow'n Away

Great design, outstanding performer, beautifully maintained.
Asking **\$239,000**



J/105, 2001, Hull #382, Anna Laura
Asking **\$105,000**



J/105, 2002, Breezy
Asking **\$117,000**



Andrews 56, 1994, Charisma
Asking **\$364,599**



J/120, 2001, OuiB5

One of North America's most successful Big Boat One Designs, the J/120 is the most versatile 40-footer afloat. At our sales dock. Asking **\$199,000**



38' X-Yachts 382, 2000, XTC
Truly a racer/cruiser, this boat is beautiful inside and out.
Asking **\$189,000**



J/100, 2005, Hull #5, Reddie Freddie
Asking **\$125,000**



J/44, 1990, Phoenix
Asking **\$219,000**

77' Andrews, '03, <i>Glory, ex-Alchemy</i> **\$950,000
70' Custom Wylie, <i>Rage</i>	\$598,000
56' Andrews, '94, <i>Charisma</i>	\$364,599
48' J/145, Hull #9, '03**\$700,000
48' Kristen, '01, <i>Trinity</i> **\$629,000
44' J/44, '90, <i>Phoenix</i>	\$219,000
41' Passport, '90, 360**\$249,900
41' Bianca 414, '80, <i>Avion</i>	Reduced! \$49,500
41' J/124, 2007, <i>Gone Again</i>	349,000
40' J/120, '01, <i>OuiB5</i>	Reduced! \$199,000
40' J/120, '95, <i>Attitude</i> **\$189,000
40' Sabre 402, '98, <i>Blow'n Away</i>	\$239,000
40' Tripp, '92, <i>Snake Oil</i> **\$85,900
40' Catalina 400 Mk II, '07**\$279,900
39' Dehler 39, '03, <i>Wild Redhead</i> **\$329,500
38' Sydney, '00, <i>Howl</i>	New Listing \$179,000
38' X-Yachts 382, '99, <i>XTC</i>	\$189,000

J/35, 1993 Pegasus
Awesome offshore racer/cruiser
Asking **\$54,000**

37' J/37, '88, Hull #30**\$105,000
37' Beneteau First 375, '85, <i>Time Warp</i> **\$69,900
36' J/109, '03, <i>Queen Bee</i>	\$215,500
36' J/36, '83**\$57,900
35' J/105, '04, Hull #634, <i>Brick House</i>	Sale Pending \$124,900
35' J/105, '04, Hull #617, formerly <i>Chili Pepper</i> **\$127,500
35' J/105, '02, Hull #519**\$119,900
35' J/105, '02, <i>Breezy</i>	New Listing \$117,000
35' J/105, '01, Hull #382, <i>Anna Laura</i>	Reduced! \$105,000

35' J/105, '99, Hull #255, <i>Roadster</i> **\$105,000
35' J/35, '93, <i>Pegasus</i>	\$54,000
34' J/34, '85, <i>The Zoo</i> **\$29,900
34' MJM 34z, '05**\$399,000
34' Classic Hans Pederson Power Yacht, '63**\$79,000
33' J/100, '05, <i>J Bird</i>	New Listing \$125,000
33' J/100, Hull #5, '05, <i>Reddie Freddie</i>	\$125,000
30' J/30, '84**\$34,000
30' Sabre, '86, <i>Buena Vida</i>	Sale Pending \$49,500
29' J/29, '85, <i>Masthead</i> **\$28,000
29' Back Cove, '05, <i>Diamond Lil</i>	Reduced! \$169,000
29' Cobalt, '01**\$69,000
27' Choate, '79, <i>Allegro Con Brio</i> **\$9,900
26' J/80, '00, <i>Risky Business</i> **\$32,000
24' Boston Whaler, '05, <i>Outrage</i> **\$69,000
22' Aquapro Raider 665, '04.....	Reduced! \$39,900

** Indicates Seattle Boats

SAIL California

www.sailcal.com • email: info@sailcal.com

DEALERS FOR THESE FINE YACHTS:

SABRE

Santa Cruz
YACHTS

BACK COVE
YACHTS

J
Boats

TrawlerFest®

BOAT SHOW – EDUCATIONAL EXPERIENCE – RENDEZVOUS

Experience the cruising-under-power lifestyle



San Diego, California

Join us at the Kona Kai Resort & Marina for an in-water boat show, seminars, and day and evening activities.

Seminar Highlights:

- Active Fin Stabilizers and How They Work — *Eric Folkestad*
- Diesel Engine Questions — *Bob Smith*
- Medical Preparedness For Passagemakers — *Denny Emory*
- The Ultimate Sea Trial — *Tony Fleming*
- Preparation For Passagemaking — *Steve & Linda Dashew*

February 26-28, 2009

90-minute Seminars: 8:30 a.m. – 12 p.m.

Boat Show: 10 a.m. – 5 p.m.

NATIONAL SPONSORS

KADEY KROGEM YACHTS
At Home On Any Sea

AMERICAN
YACHTS

GB
GRAND BANKS

Landfall
WHERE SAFE VOYAGES BEGIN

JEPPESEN
MARINE

Selene
Ocean Trawler

NORDIC
TUGS

OUTER REEF YACHTS
40% Aboard, 60% Offboard

NORDHAVN

REGIONAL SPONSOR

JOHN DEERE

OCEAN NAVIGATOR
NAVIGATIONAL SYSTEMS

THE LOG

Soundings
Real Estate, Real Estate

Sea
SAILING

YACHTWORLD
COM

for pricing and event information:
trawlerfest.com 888-487-2953

LETTERS

reasonable.

The important thing, of course, is to establish a fast, economical, reliable and quiet internet base, where you can both work and make calls on Skype. Using Skype allows you to call all over the world for nothing. Your satphone expenses will likely drop to almost nothing. As for your heating bills, those will be a thing of the past.

↑↓ I CAN GET BY ON \$100 A WEEK IF I HUNKER DOWN

The Christmas Trades here in the middle of the Eastern Caribbean have finally calmed down enough so the sailing conditions are becoming decent. The period between the wet and dry seasons started later than normal this year, lasted longer, and was more robust than is typical.

It's my understanding that two charter cats were lost this year. The one that I heard about involved a French family on a bareboat charter out of Martinique. Apparently there was some bad boat handling in high wind and seas. The family drifted in a liferaft for four days until they were picked up by the Trinidad Coast Guard. To me, the skipper's account of the whole thing sounded like an attempt to save face.

Originally from Alameda, I've been cruising the Caribbean for quite a few years now, so I know what I spend. I live on the \$1,685 I receive from Social Security each month, and \$95 a month is deducted from it for Medicare. If I want to hunker down and not dine out, I can live on as little as \$100 a week. But I generally spend about \$200 a week on myself. When the diesel engine on my boat finally gave out after about 25 years, I had to use some of my savings to replace it. But I used my debit card and got enough travel miles to fly to the States and back. My boat is self-insured, so there's no expense there.

John Anderton
Sanderling, Cabo Rico 38
Formerly Alameda / Now the Caribbean

Readers — We don't want to give people the wrong idea about the cost of cruising, as some cruisers spend a ton of money. In fact, we're working on an interview with some Southern California folks who have been out cruising for three years now, and manage to spend about \$100,000 a year. When you read their story, you'll see how this is possible.

↑↓ DID YOU MEAN FEET OR YARDS?

In *Latitude's* response to a letter asking how far out to sea a deceased's ashes must be spread, you said 500 feet. Are you sure? Wouldn't that be just beyond the surf line? I think it should be more like three miles. After all, that's how far out you have to be to throw organic material overboard. And that's what spreading ashes really is, putting the organic remains of a human — albeit a little overcooked — in the sea. Most of the 'ashes' sink, for they are composed of pulverized bones, but there is a fine dust which remains on the surface. When mixed with flower petals, I'm sure this concoction of human remains floats for some time.

If 500 feet is the correct distance, would it be legal to walk to the end of a pier that length and dump Uncle Charlie in the water?

Jim Barden
Martes, Iroquois 32 Mk2a
Marina del Rey

J.B. — Sorry, but we certainly did make a mistake. The legal distance offshore in California is 500 yards from either a navigable waterway or the ocean. Furthermore, it's not legal to spread ashes from piers or wharves. But given the cynicism



SOLIATH — 

Armed solely with a brand new kind of sailmaking technology, the lone Quantum entry at the 2008 Audi Med Cup and TP52 World Championship played the giant. To learn more about this story of biblical proportions, visit us at www.quantumsails.com

Quantum Pacific
1230 Brickyard Cove Rd
Point Richmond, CA 94801
sanfrancisco@quantumsails.com
510.234.4334
ANTICIPATE THE SHIFT



Tens of thousands of
Satisfied Graduates since 1976



U.S. Coast Guard approved
courses and testing.

Approved for Veterans.

Captain's License

and now offering
ONLINE Courses

New Bay Area Class!

BERKELEY

**Feb 23
though
Mar 6th
at**



OCSC™ SAILING
Inspire Confidence™

RADAR • RADIO • NAVIGATION • SAFETY

MARITIME INSTITUTE

**THE BEST ONLINE COURSES AVAILABLE!
CALL TOLL FREE 888-262-8020**

OR visit our website for more information.

www.MaritimeInstitute.com

**Over 40 Accredited and
U.S. Coast Guard Approved Courses.**

LETTERS

the public justifiably feels for government these days, you can be sure the laws for spreading ashes in California are violated all the time. Not only do people not get permits from the city they spread them from or report the spreading to the EPA afterwards, but they disperse ashes from piers and wharves, from the Golden Gate Bridge, and from boats when less than 500 yards offshore.

Come to think of it, President Barack Obama is already in hot water with some environmentalists in Hawaii for the way in which he spread his grandmother's ashes in late December. You may remember that he and members of his extended family spread his grandmother's ashes from a sandy shore on Oahu. That was a no-no, for in Hawaii, the Department of Land and Natural Resources requires that ashes be spread at least three miles offshore. Given these contentious times, we're sure some idiot will say this is grounds for impeachment.

↑↓ **FLIP FLOPPING FLAGS**

Can anyone tell me what flag Tom Perkins' 289-ft *Maltese Falcon* sails under? It sort of looks like Bermuda's but it's not.

John Mocnik
Los Altos

John — We'd assumed that Falcon had been flying the flag of Malta while on the Bay, but upon further investigation, discovered that was wrong. So we wrote Capt. Chris Gartner, who provided the complete explanation:

"While sailing on San Francisco Bay, we were flying the flag of the Cayman Islands. But when we added our submarine — actually an 'underwater jet' — we had to reflag her because the Cayman Islands doesn't allow them. Malta does permit submarines, so now we're flying their flag. Cool, huh?"

Cool indeed! What wasn't cool was Falcon's trip from the Panama Canal to Antigua in November. "It was the roughest trip we've had with her to date," said Gartner, "as the unstayed masts were whipping all around in the heavy seas."

While anchored in St. Barth in the second week of January, we noticed the distinctive shape of Maltese Falcon on the horizon. She's different, and took some time to get used to, but she looks pretty hot!

↑↓ **SINGLEHANDING WITH A WOMAN . . . HOW FRENCH!**

Kudos and glory for *Latitude's* lists of sailing records, West Coast circumnavigators, lonely circumnavigators and other references. Such a scholarly approach combined with *Latitude's* flamboyant style is a unique treat.

But there are other lists that are not so glorious. As a person who has spent four decades doing research on singlehanded sailing — my doctoral thesis was *World Singlehanded Sailing 1876-1993* — I like to call attention to inaccuracies in some of the solo circumnavigator lists published on the internet.

The problem with inaccuracies in such lists started half a century ago, when French author Jean Merrien published his well-known *Lonely Voyagers* (Putnam, 1954). The book, written with a Gallic lightness, included different categories of 'singlehanded' circumnavigators, including: 'Almost Alone', 'Alone With A Kid', 'Alone With A Woman'(!), 'Alone With A Friend' and 'Almost Around The World', to name a few.

Lonely Voyagers spoiled all subsequent lists, as many subsequent compilers just copied Merrien's erratic and inaccurate list, not even bothering to do the simplest research, such as reading the books written by the solo — or not-so-solo — circumnavigators.

Reviewing almost all available documents about solo sail-



MODERN SAILING SCHOOL & CLUB

Sausalito, CA www.ModernSailing.com 800-995-1668

Heavy Weather Offshore Course (ASA 105, 106)

Because of dynamic conditions that present challenges even to experienced sailors, the California Coast provides the perfect setting for training students at the advanced level. Join John Connolly on our well-equipped Islander 53' for a 7 day trip to Monterey and back. Space is limited. Enroll today!

April 20 - 26

Includes ASA 105, 106.
Cost is \$1675

Advanced ASA Certifications in Exotic Locations!



GREECE & ITALY

Both legs offer Advanced Coastal Cruising, ASA 106.

Rich with historical significance, this trip is not to be missed. Join us in the Mediterranean on this exotic adventure and book your cabin today!

Leg 1: Sept. 21 - Oct. 1, 2009 (Lefkas - Sicily)

Leg 2: Oct. 4 - 14, 2009 (Sicily - Lefkas)

\$2675 / berth
\$4850 / cabin

Spain - only 3 spots left! Mallorca, Menorca, Ibiza

Improve your sailing skills and gain valuable cruising experience. Leg 3 offers Advanced Coastal Cruising, ASA 106.

LEG 3: March 31 - April 9, 2009

\$2175 / berth
\$3950 / cabin



Captain's Licensing Course

February 16 - 28
2 week intensive

OUPV LICENSE - \$995
100 TON LICENSE - \$1195

Our GUARANTEED, U.S. Coast Guard Approved course will prepare you for all elements of the exam, guide you through the application process, and conclude with on-site testing.

Prepare to Go Cruising Seminar

with John Connolly

Golden Gate Yacht Club on Sunday, Feb. 22 (8am - 5pm)
\$95 (\$80 for MSSC and GGYC members)

Reserve your spot today!

- ▲ World Destinations
- ▲ Circumnavigating
- ▲ Choosing a Boat / Equipment
- ▲ Life Raft Demo
- ▲ Sails and Rigging
- ▲ Storm Strategies



John Connolly - As Modern Sailing's Head Instructor, John has taught advanced sailing courses world wide, and over 100 along the California Coast. Sailing all over the world, he has become an expert in equipment and boat selections as well as heavy weather.

Other Expert Speakers and Presenters Include:

Jim Leech of

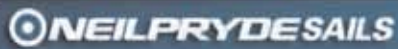

Sal Sanchez of Sal's Inflatable

For a complete schedule or to register - give us a call, (415) 331 - 8250

PREPARE TO TAKE THE HELM

Your sport.
Your money.
Your way to save.

Announcing MemberShip
Pricing for Marine Supplies

A 7,000 Sq. Ft.
Warehouse & Chandlery

Large Inventory

All Name Brands

Expert Advice

Centrally Located

Free Annual Membership
during Enrollment Period.

Opening April 1, 2009.

To register visit:
www.mship.com

LETTERS

ing, I discovered that such pillars of the history of solo sailing as Tom Drake, Yves Toumelin, Pierre Auboiron, Michel Mermod, Wolf Hausner and others, never completed solo circumnavigations! And in an even more interesting case, the Slocum Society list is lacking several well-known solo circumnavigators. In fact, it appears that most of them were removed from the list after they resigned their memberships in the Slocum Society!

All right, no more lamenting from me, because 'boys don't cry'. *Chapeau bas!* Be positive, gentleman. So which among all internet lists of solo circumnavigators is most accurate? I nominate the one compiled by Richard Konkolski — who was a BOC finalist in '83 and '87 — which can be found at www.solocircumnavigation.com.

Since I'm writing, I want to give three cheers — if not more — to the magnificent men (and women!) in their sailing machines who are now doing singlehanded circumnavigations as part of the Vendée Globe. They are truly titans of the oceans. Good luck to them!

Andrew Urbanczyk
Montara

Readers — Longtime readers will remember that Urbanczyk wrote a column for Latitude for several years. He knew what he was talking about, too, having singlehanded an Ericson 27, of all boats, from San Francisco to Japan and back. He later did a solo circumnavigation with an Ericson 30+. Wait a minute, we have to amend that, as it wasn't actually a solo circumnavigation, but rather a Solo Circumnavigation With A Cat!

↑↓AND WHAT A FANTASY WORLD IT IS

I hate to spoil the opinion of your favorite correspondent, Heather Corsaro, but her comments about the weather in La Paz, as published in the January 7 *'Lectronic Latitude*, are a bunch of crap! According to her report, ". . . it wouldn't be so bad except that it's freezing! I swear it's going to snow or we'll wake up to see frost on the decks. We've had a bit of rain this past week and chilly winds in the 15- to 18-knot range."

I've been here in La Paz since the end of the Ha-Ha, and while the nighttime temps get down to about 60°, the days are in the mid-70s. I have worn shorts and a tank top every day since November, and it has not rained once. Heather must be living in some fantasy world.

Michael Kary
Beyond, Darwin 37
San Francisco

Michael — We're all living in a fantasy world — Heather's is just more entertaining than most of ours. As for the weather, we assume that Heather was speaking about it figuratively rather than literally. Besides, she'd just come to La Paz from the much warmer air and water temps of the mainland. That said, it's not uncommon for people to be inaccurate about the climate. For example, the minute we received your email saying that nighttime temperatures in La Paz "get down to about 60°," the Weather Channel and other resources were reporting 48° in La Paz.

To get a more accurate picture of the weather situation in La Paz, we checked the Weather Channel's 10-day forecast. It was almost the same for all 10 days, with highs in the mid to high 70s and lows in the mid 50s to 60s. Very nice indeed. But the thing to remember about winter weather in La Paz is that it can vary greatly. As Neil Shroyer of Marina de La Paz once told us, the winter weather is very nice about half the time, and cool if not downright cold the other half. The problem is that it's

Yachtfinders/Windseakers

in the heart of
San Diego's boating community

2330 Shelter Island Dr. # 207, San Diego, CA 92106

info@yachtfinders.biz

(619) 224-2349

Toll Free (866) 341-6189

Go to
www.yachtfinders.biz
for all our listings!



74' ASTILLERO ORTHOLAN, '41 \$299,500
Sundancer has a light, airy interior in a solidly-built hull. She is a handsome yacht with comfortable living areas, capable of world cruising.



45' TRITON PACIFICA, '74 \$99,900
Versatile cutter rig, wide decks and large fuel and water tankage make this a go-anywhere boat. Accommodations and layout for a cruising family.



30' NEWPORT, '74 \$11,500
Here is a strong, capable cruiser/racer with a very roomy interior. She will do well for a couple or small family and makes a great starter boat.



45' DUFOUR 455, 2006
\$349,000

Froia II is a proven performance cruiser with modern design, dual helms, wide teak decks, an extensive sail inventory and a long list of electronics. Inside, there is a rich Moabi wood interior with plenty of natural light to highlight her functional four-stateroom interior.



44' MASON, 1985
\$244,500

One word says it all: MASON. Beautiful interior boasts luxurious green upholstery and a well-equipped galley. This boat has seen many upgrades since 2000. She has electric primary winches, furling mainsail and SSB and she is ready for offshore - wherever that may be for you!



39' HALLBERG-RASSY Mk II, 2000
\$289,000

Meticulous attention to detail, quality construction and outstanding engineering make *Maja* a stunning yacht. Built for safety in offshore conditions, but easy to handle and elegant around the bay, this Hallberg-Rassy will surpass your highest expectations. Come and see her!



54' CUST. ROBERTS SLOOP, '85 \$179,900
A stable cruiser with steel structure for peace of mind. Her sugar scoop allows easy onboard access and her huge back deck holds a large dinghy.



34' CATALINA, '88 \$44,900
Mira sports distinctive styling, fast performance, an easy-to-handle rig, a large useful cockpit and a spacious interior. Call to see her today!



28' TWISTER, '86 \$34,900
This well-mannered offshore cruising boat is your ticket to freedom! She's heavily-built and great for sailing the bay - and for crossing oceans.



Looking to Buy a Boat to Cruise South to Mexico or Beyond?

The boat you are looking for is either in Mazatlan or La Paz. These are proven, cruise ready boats, all have been outfitted, and all have made the trip from the U.S., Canada or other countries. Successfully Selling Boats in Mexico since 1998.

Size Brand / model	Year	Price
SAIL		
54 Custom DeWar cutter ketch	1983	149,900
54 Hunter sloop	1984	105,000
50 Gulfstar CC ketch	1979	119,000
50 Hudson pilothouse ketch	1979	89,000
50 Kettenberg sloop	1962	128,000
46 Hunter 460 cutter sloop	2000	235,000
46 Morgan 462 CC ketch	1981	99,000
46 Denmark steel ketch	1966	69,900
45 Hunter 450 Passage CC	1998	199,000
45 Island Trader CC cutter ketch	1979	142,000
44 Hylas sloop	1991	210,000
44 Kelly Peterson	1979	110,000
44 Peterson KP44 cutter	1978	95,000
43 Irwin MK III	1989	114,000
43 Spindrift PH	1981	134,500
42 Sabre Sloop	1986	140,000
42 Whitby	1975	140,000
41 Cooper US 42 pilothouse	1981	89,000
41 Morgan OI 415 ketch	1979	69,900
41 Ta Chiao CT ketch	1977	150,000
41 Tartan TOCK	1976	95,000
41 Formosa Yankee Clipper	1974	92,500
41 Morgan 414 ketch	1974	42,500
41 CT ketch	1973	49,900
41 Tartan sloop	1973	75,000
40 Roberts cutter	1997	98,000
40 Passport sloop	1982	145,000
40 Piver Victress trimaran	1965	35,000
39 Roberts 392 PH steel cutter	1993	165,000

39 Cal	1980	74,900
38 Nauticat motorsailer	1983	100,000
38 Robert ketch	1982	55,000
38 Shannon cutter	1980	109,900
38 Hans Christian Traditional	1979	89,900
38 Bluewater Ingrid ketch	1974	50,000
38 Oriental Moore ketch	1963	24,900
37 Pearson sloop	1989	59,900
37 Hunter Legend sloop	1988	69,000
37 Hunter Cherubini cutter	1979	34,500
37 Rafiki cutter	1978	80,000
37 Condor UK	1978	32,000
37 Irwin CC sloop	1976	56,000
37 Tayana ketch	1975	65,000
36 Union cutter	1987	TBA
36 Union cutter	1983	89,900
36 Pearson 367 cutter	1982	TBA
36 CSY Watkins sloop	1981	TBA
36 Islander sloop	1980	46,500
36 Pearson sloop	1977	44,900
35 Wauquiez Pretorian sloop	1985	82,500
35 Columbia Challenger ketch	1974	28,000
34 Catalina sloop	1986	29,900
34 Hunter sloop	1985	44,500
34 Finngulf	1983	43,500
34 Hunter sloop	1983	31,000
34 C & C sloop	1978	40,000
34 Downeast cutter	1978	34,900
34 Tartan centerboard	1972	27,900
32 Westsail cutter	1981	68,500
32 Dreadnaught ketch	1980	38,000
32 Morgan custom sloop	1979	37,500
32 Downeast cutter	1976	31,000
31 Pacific Seacraft Mariah cutter	1979	55,000
31 Brown Searunner trimaran	1978	32,000

30 Newport MK III	1984	16,500
29 Bayfield cutter	1978	25,000
28 Bahama Sharpshooter	1950	39,500
27 Corsair F-27 trimaran w/trailer	1991	46,000
27 Catalina w/trailer	1973	12,000
20 Pacific Seacraft Flicka	1978	25,000
POWER		
65 Pacific Mariner motoryacht	1999	1,000,000
64 Woods trawler	1972	290,000
60 Gladding & Hearn pilot	1960	219,000
55 Sunseeker Carmague Express	1994	430,000
53 DeFever custom POC	1983	345,000
53 Hatteras yachtfish cockpit FB	1980	224,900
52 DeFever trawler	1970	125,000
50 Carver motoryacht	1999	329,000
48 Tollycraft motoryacht	1976	160,000
47 Santa Barbara Yachts	1964	75,900
45 CHB Sedan trawler	1981	169,000
44 Sea Ray Express	1996	179,000
43 Silverton sport bridge	2006	440,000
43 Custom flybridge sportfisher	1993	36,000
42 Betram convertible	1985	180,000
42 Californian coastal trawler	1979	99,500
42 Grand Banks trawler	1970	69,000
40 Hatteras convertible sportfish	1968	95,000
39 Bayliner 3988	1998	165,000
39 Sea Ray Express	1989	80,000
35 Egg Harbor Golden Egg	1997	149,000
34 Uniflite Sedan sportfisher	1984	80,000
34 Chien Hwa trawler	1978	54,900
32 Blackfin Combi w/charter	1989	125,000
32 Uniflite sedan sportfisher	1977	25,000
29 Fountain sportfisher	1996	27,500
21 Custom launch	1988	12,200



Ray Watson & Jeannette Sarrasin
Toll free US/CAN: 1 (888) 716-7430
Phone & FAX: 011 52 (669) 913-3165
E-mail: Mazmarine@aol.com

Compare our listings
and see our
"Testimonials"
at MazMarine.com

Mike Rickman & Shelly R. Ward
Toll free US/CAN: 1 (877) 245-9689
Phone: 011 52 (612) 123-1948
E-mail: LaPazYachts@aol.com



Milltech Marine

Complete AIS Solutions

The Automatic Identification System (AIS) is the latest collision-avoidance solution for boaters.

AIS receivers enable AIS-capable chart plotters and navigation software to see other vessels. AIS transponders allow other vessels to see you.

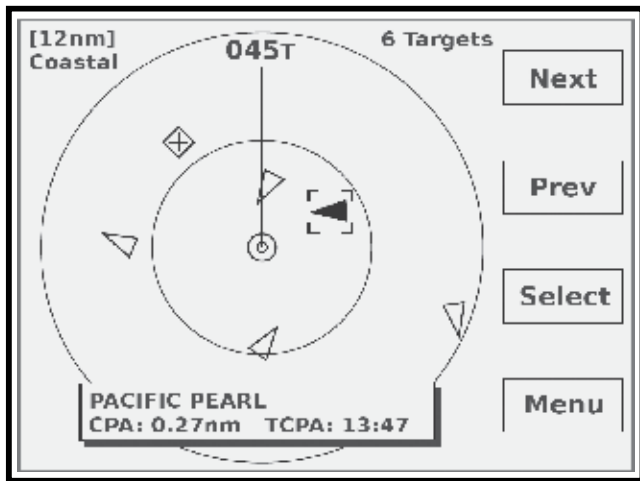

AIS WatchMate displaying AIS targets

Milltech Marine offers complete, low-cost AIS solutions from Comar, Smart Radio, ACR, Vesper Marine, Rose Point and others including:

- ✿ AIS receivers from \$189
- ✿ AIS transponder kits from less than \$700
- ✿ AIS WatchMate display from Vesper Marine
- ✿ Coastal Explorer navigation software
- ✿ Antennas, cables and other accessories

Class B AIS Transponders now available!



For more information contact:

Milltech Marine
(206) 299-2217

www.MilltechMarine.com

LETTERS

50-50 over a long period of time rather than just a matter of days or weeks. It's been Shroyer's experience that La Paz can have entire months — indeed entire winters — that are either very pleasant or quite chilly. Unlike on the mainland, there is no guarantee of warm weather.

In any event, we're glad everyone in La Paz — except maybe Heather — has been having shorts and T-shirt weather so far this season, and hope it continues throughout the winter.

Update: On January 9, Michael wrote that the first big Norther of the season was expected in La Paz and that the local net was reporting the water temperature as 70°.

↑↓ WE WERE QUITE COMFORTABLE AT CHRISTMAS

I read the January 7 *Lectronic* piece on the supposed cold weather in La Paz with much amusement. Our family spent 10 days in the Sea of Cortez over Christmas, and I'm happy to report that we encountered air temps in the high 70s to



The Haas Family didn't feel the chill during their 10 days in the Sea of Cortez in December.

low 80s. Furthermore, the water was quite comfortable at what I would guess to be 75°. It wasn't a shock for us to dive in and go for a snorkel — although I'd have worn a wetsuit if I'd gone scuba diving. We kite-boarded off the south end of Isla San Jose, and afterwards I'd soap up and take a saltwater shower with no discomfort. The air temperature was probably 80°. We spent evenings in the cockpit, BBQ'd off the stern, all in very comfortable temperatures. But don't tell anyone, because the anchorages were almost empty, and we want to keep them that way.

Ken Haas
Liahona, Moorings 4200 cat
La Paz / Orinda

Ken — As explained in the previous response, we're not surprised that you got high 70s and even low 80° air temperatures around Christmas. But the 75° water is warmer than we'd have thought, and is probably a function of the fact that no big



A big Norther will cool off the waters in the Sea quickly, making for chilly swimming conditions.

Northers had blown down the Sea yet this season. Some years, the Northers start as early as mid-November, and they cool the water down quickly.

For what it's worth, most 20/20 cruisers — meaning those who spend most of their time between 20° N and 20° S, and whose blood has thinned — think 80° water is the borderline between comfortable and too cold

EXPAND YOUR SKILLS WITH AN OCEAN OR COASTAL PASSAGE



OFFSHORE SAIL TRAINING ABOARD 65' ALASKA EAGLE

Learn what it takes to make a major cruise under sail. Along with eight other crewmembers, you'll sail in all conditions, standing watches and steering as *Alaska Eagle* sails 180 to 240 miles a day. Our emphasis is on helping you build skills in an environment of fun and great sailing. Many who sail with us are planning voyages of their own. There is no better way to prepare.

Newport Beach to Cabo San Lucas

As the communications vessel, *Eagle* won't be racing for hardware but she will be sailed to her potential. Lots of downwind sailing and a short respite in Turtle Bay. This is a great way to hone skills for those thinking of a Mexico trip on their own boat.

Fee: \$1695 • Mar. 9-15, 2009

Baja Bash

Using a combination of motor and close hauled sailing, crews will learn the techniques of working against wind and current. Stops may be made in well-known "weather holes". While we can't guarantee rough weather, there is usually a healthy dose of it.

Fee: \$1495 • Mar. 18-26, 2009

San Francisco - Newport Beach, CA

Sail under the Golden Gate Bridge and down the coast, stopping at a mixture of remote and popular anchorages. Days are filled with sailing, radar watch, navigation and watch standing while running 24 hours.

Fee: \$1495 • April 2009

After the Strictly Sail Boat Show

Newport Beach, CA - Honolulu, Hawaii (Transpac Race)

Alaska Eagle will be the communications vessel for the Transpac Race. June 29 - July 12, 2009

Honolulu, Hawaii - Victoria, Canada

Experience a classic ocean passage. Conditions will vary from fast reaches to the calm center of the Pacific High. Snow capped mountains provide a stunning backdrop as *Eagle* sails down the Straits of Juan de Fuca and into Victoria.

Fee: \$3395 • July 15 - Aug. 2, 2009

Pacific Northwest Adventure

This **all women's trip** incorporates practical lessons in navigation, weather and sailing a big, beautiful boat, under the tutelage of three very experienced women sailors. We aren't looking for experts, but like all our legs, intermediate sailing is a prerequisite.

Fee: \$2295 • Aug. 5 - 16, 2009

Victoria, Canada - San Francisco, CA

You will maneuver around traffic, navigate in diverse conditions, and study weather on this leg. A stop (or two) down the coast provides a chance to experience landfall, sometimes with a dramatic bar crossing.

Fee: \$2495 • Aug. 20 - Sept. 1, 2009

San Francisco - Newport Beach, CA

The thrill of sailing under the Golden Gate Bridge is just the beginning. Stops at remote and popular anchorages make this a perfect introduction to coastal passage making.

Fee: \$1495 • Sept. 4-10, 2009

To learn more: www.occsailing.com

To request a color catalog or specific info: 949-645-9412

Or write: *Alaska Eagle* Voyages,

1801 W. Coast Hwy, Newport Beach, CA 92663

The School of
SAILING & SEAMANSHIP
 | Orange Coast College



GREAT DEALS ON LUNASEA & OPTOLAMP LIGHTING!

NAV LIGHT LED AMAZONIA TRICOLOR OPTOLAMP List \$288



SALE PRICE \$207.36!

The development of the OPTOLAMP® line was based in long cruising sails around the world, where life required low energy consumption and a secure signalling and illumination in all weather conditions.



15% OFF LIST PRICE!

FLUORESCENTS...



**BOTH
HIGH OUT
WHITE
AND
RED!!**

LUNASEA offers the solution of high output light in white and red, both in one package.

35W. EQUIV. NEMA 4 DIMMABLE FLUSH-MOUNT LED - COOL WHITE

Only LUNASEA builds 100% dimming capability into every light and features a ten second fade-to-off press and hold switch, that lets you leave the room before the lights go out. Lunasea's state of the art design systems are easy to install, easy to upgrade, and best of all, Lunasea offers top-value lighting solutions that will meet or exceed your expectations while staying within your budget!



**SVENDSEN'S
MARINE**

**LOCATED IN THE
ALAMEDA MARINA
1851 Clement Avenue
Alameda • 510.521.8454
Open 7 Days a Week**

LETTERS

for swimming. Many of them wouldn't dream of swimming in 75° water, so yes, they get sissified by the tropical water temperatures.

↑↓ HEADROOM SHOULD BE A TOP PRIORITY

I enjoyed Liz Clark's description of the good times she had in the Tahitian boatyard. Ah, the joys of grinding grit, cold showers and communal heads! During my 10-week liveaboard odyssey in Seattle, I also encountered homeless guys sleep-



COURTESY ROMANY STAR

Tall sailors on small boats quickly develop lumpy heads.

ing in boats, and smoking and drinking in the head. But maybe that's a Seattle specialty; those guys gotta keep out of the rain.

We've had a great time in Mexico for the last two years, but it's time to move on. Some bits of advice to cruisers-to-be: If fortunate enough to cruise in Mexico, go

north in the Sea of Cortez, for places such as Bahia de Los Angeles are not to be missed. If you're choosing a boat and you're tall, make headroom a priority — unless you like dents in your noggin. If you're going to put together a medical kit in Mexico, we've posted some pointers — and the list of contents in our med kit — at www.romanystar.com.

We're bound for the Galapagos and the Gambiers, so we'll be attending the Zihua Puddle Jump meeting in February.

Erin & Paul Moore
Romany Star, Ohlson 38
Seattle

↑↓ SMALLER IS BETTER IN SOME PLACES

I have a brief comment on the 'Tips For The Class of '08-'09' article by *Raptor Dance*, that appeared in September's *Changes*. I agree that a high-quality dinghy and reliable outboard are critical pieces of equipment for the cruiser, and I agree that it's fun to go fast and cover long distances quickly. But cruisers who anticipate traveling beyond Mexico might want to know that the most popular and sought after outboard motor in the South Pacific is the two-stroke Yamaha 2-hp. The Mercury 3.3-hp comes in second, but only with those who can't find a Yamaha. The reasons for the popularity of the little Yamaha are reliability, low cost and the limited availability of clean fuel.

Almost everyone in the Pacific — local fishermen, dive operators, village boats and long-time cruisers — use Yahas because of their reputation for reliability. In addition, there are dealers out here, and parts and service are also available. No other brand of outboard comes close.

Fuel remains very expensive in the South Pacific. I paid \$10.50/gallon in Tuvalu last June, and \$12/gallon in parts of Vanuatu. And I was glad to pay it, because at least it was available. I've been in Vava'u, Tonga, for weeks on end when there was no fuel to be had. And I've been in Vanuatu when there wasn't fuel for months. In situations such as these, the owners of humble 2-hp Yamahas are in much better shape than those who own 15-hp Yamahas that burn so much more fuel. Out here in the South Pacific, fuel conservation is not optional, which is why more and more cruisers are going with hard dinghies such as the Glacier Bay. Unlike inflatables, it's easy to effectively row a hard dinghy.

Although I know that new two-stroke outboards are no

COME VISIT COYOTE POINT MARINA:

The Peninsula's Complete Recreational Destination!



BERTHING

- Slips to 40' available
- 22' inside ties for \$85 per mo.
- Multihull side ties available
- Check out our rates!



FUEL DOCK & PUMP OUT

- Open 7 days per week
- Gas and diesel available
- Check our prices
- Free pump outs



COYOTE POINT RECREATIONAL AREA – HOME TO:

- Coyote Point Marina
- Poplar Creek Golf Course
- Coyote Point Park
- Captain's House Conference Center
- Beach, Picnic & BBQ Areas
- Coyote Point Yacht Club
- Dominic's Restaurant
- Magic Mountain Playground
- Coyote Point Museum
- Shoreline Trail

COME FOR A VISIT – WE THINK YOU'LL STAY

Call us and mention this ad for a FREE One Night Guest Berth

COYOTE POINT MARINA ~ 1900 Coyote Point Drive • San Mateo

650.573.2594

CRUISE OR RACE WITH THE SAME SUIT OF SAILS: UK-HALSEY.



WINTER DISCOUNTS
In February
As little as two weeks
delivery time!

"My Luders 33 Endeavour may be a lot older than your boat, but my UK-Halsey Tape-Drive sails keep you from noticing anything but her speed," says owner Bill Conron.

CONVENIENCE AND
SATISFACTION FROM
USING FAST SAILS
THAT LAST.



NORTHERN CALIFORNIA
(510) 523-3966

Now in Grand Marina
sanfrancisco@ukhalsey.com

Stop by our new loft at
2021 Alaska Packer Place
in Alameda and say hello.

MARINA DEL REY
(310) 822-1203

NEWPORT BEACH
(949) 723-9270

SAN DIEGO
(619) 226-2131
uksd@uksocal.com

www.ukhalsey.com

LETTERS

longer available in the U.S., it might be worth the hassle of mail ordering one from one of the bigger chandleries in Australia — or better yet, New Zealand. Why? It's no secret that the quality of fuel in the South Pacific can be abysmal. In Tonga, for instance, gas is usually a mixture of low-grade gas, undrinkable water and fine abrasive particles. Two-strokes do a better job of gagging this down than do four-strokes. And when the witches' brew finally does clog up the works, the simple carb on the 2-hp Yamaha is easy to self-service.

By the way, wheels for dinghies are useless after Mexico, and still having them on your dinghy identifies you as being new to the South Pacific.

Nick Nicolle
Rise & Shine
Majuro, Marshall Islands

Nick — Thank you for the insight, as we can't recall anyone's raising that significant issue before.

However, we do have to correct you on the availability of two-strokes in the United States. You can buy Yamaha two-stroke outboards in many states — such as Nevada and Arizona — but not in California. However, you cannot call a dealer in Nevada or Reno and have him ship one to you, as it's illegal. You have to buy one out of state and 'smuggle' it into California. And yes, people do it — although not quickly, as it's hard to find these outboards in stock in Nevada and Arizona. Furthermore, Yamaha has a limited quota of two-strokes they are allowed to bring into the States each year.

The bad news is that Yamaha no longer makes small two-strokes. The smallest they now offer are the 8, 9.9, 15, and 25-hp. When it comes to four-strokes, which are admittedly heavier and more complex to repair, Yamaha offers a 2.5, 4, 6, 9.9 and 15. However, four-strokes are quieter and about 30% more fuel-efficient.

The bottom line is that, if you've got a Yamaha two-stroke 2-hp, you've got a desirable commodity that is no longer being made.

OFFICIAL MEMBER OF THE OVER 30 CLUB

I smiled with pride when I saw the photo of the beautiful Mariholm IFB on the cover of January issue of *Latitude 38*. I noted that this IFB is an older model from the late '60s or very early '70s.

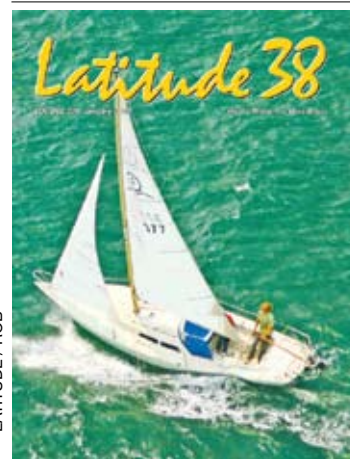

LATITUDE / ROB

These boats were built in Sweden from a design submitted by Tord Sundén, an amateur designer who had been the chairman of the committee that designed the original Folkboat in the '30s. The IFB was a most successful design, as approximately 8,000 of these lovely boats were built and sailed all over Europe. Many of them also ended up on San Francisco Bay and the Chesapeake Bay.

Tord Sundén designed the Nordic Folkboat before drawing up the IFB.

The brochure from 1974 showed two adults, two children, a golden retriever, and what looks like a mother-in-law, all on the boat making dinner. The father and mother were dressed like they'd just finished a race on their beloved IFB.



MARINA BAY YACHT HARBOR

A Certified Clean Marina

www.MarinaBayYachtHarbor.com

(510) 236-1013

1340 Marina Way South, Richmond, CA 94804



Your Boat's Home on the Bay *Right Where You Want to Be*



- A Sunnier, Warmer East Bay Marina
- Restaurant & Deli
- 24-Hour Courtesy Patrol

- Deep Draft Harbor (race boat friendly)
- Berth to Bay in 15 Minutes
- Nearby Boatyards, Chandleries and Fuel



Tradewinds Sailing School and Club ~ www.tradewindssailing.com

Cleaner and Greener

PURE OCEANS®



NEW! Pure Oceans Boat Care Products

West Marine is proud to introduce our new Pure Oceans line, a new selection of boat care products that have been specifically formulated to be kinder to the environment while delivering performance that equals less environmentally-friendly formulas. The Pure Oceans line includes soaps, cleaners and surface care products that are inherently less toxic, less environmentally persistent, less bio-accumulative and that degrade to substances with similar desirable characteristics when compared to ingredients in conventional formulations. Be good to your boat, and be good to the environment with West Marine's new Pure Oceans Boat Care Products.

West Marine®
We make boating more fun!®

Visit our **Alameda Sailing Superstore!**
730 Buena Vista Ave. • 510-521-4865

We have 22 stores in Northern California.
Log onto westmarine.com or call **1-800-BOATING**
to find the store nearest you.

LETTERS

I note that the skipper of the IFB on the cover of *Latitude* has set his boat up for serious cruising, with what looks like a masthead light and self-steering. The crew is dry under the dodger.

I waited for 10 months to get my IFB delivered to Oakland in '75, and I have been sailing her ever since taking delivery. I'd tried to find a used one, but no one would sell me theirs, so I was forced to pay \$16,000 — a lot of money back then — for a loaded IFB with a Volvo diesel. I have gradually upgraded my boat, and when I became too old to interest young crew, set her up for singlehanded sailing with a furling jib and Dutchman system for the main. They make sailing easy.

Leonard Brant

Michelle, Mariholm International Folkboat
San Francisco

Leonard — We're delighted that the cover brought a smile to your face. Since you've been an IFB sailor for so long, perhaps you remember the name of the minister from the Peninsula who singlehanded his IFB from San Francisco to New Zealand about 20 years ago. That was quite an achievement for the skipper and speaks highly of the design.

We also want to salute you for being one of the few sailors who has owned the same boat for more than 30 years. Is there anybody else out there in the 'Over 30 Boat Club'?

↑↓ THE TRICK IS TO CREATE A WIN-WIN SITUATION

I'm writing in response to the January letter by Jon Christensen and Stu Seymour, who wondered about the possibility of their helping pay to deliver a boat from the West Coast to the East Coast in return for getting to enjoy cruising her along the way. I'm also writing in response to *Latitude's* editorial comment, which basically was that if the guys were experienced enough, they could probably do a delivery and enjoy the boat, and perhaps not have to contribute much money at all.

In '03, we did something like what Jon and Stu would like to do. We successfully 'borrowed' a 65-ft wooden trawler based in San Francisco for a 10-month cruise to Mexico. The 'we' were two families — four adults and three kids aged 8-10 at the time.

We were experienced sailors who wanted to take a year off and do the Sea of Cortez, and had been looking to buy a boat



PAT CONROY

Pat Conroy's delivery arrangement was successful but it took more than a smile and a handshake.

for such a trip. To briefly recap, we met an older couple with a great boat, became friends and earned their trust and respect. After six months of sweat equity from our working on the boat, a big yard bill paid by the owners, a variety of gear and safety upgrades paid by us, a legal agreement signed by all parties, and a large deposit left by us to deliver the boat back to San Francisco if we bailed out somewhere down south, we were on our way.

So yes, it can work, but there are a whole bunch of details that need to be worked out. I have always believed that there are lots of unselfish boatowners who would like to see their boats

ANDERSON'S BOAT YARD

Where do you go if you need to haul out an 80-ft cigarette boat?
ANDERSON'S of course!



The #1 Boat Yard on the Bay!

*All of us at Anderson's
would like to thank
all our customers
for choosing the
#1 boatyard
on the Bay.*

Call now to reserve space for:

- Sprayed racing bottoms
- Custom topside paint jobs
- Complete rigging shop
- Custom metal fabrication
- Electrical installation & repairs
- Engine service and repower

***Come see us
for your
boating needs!***

**400 HARBOR DRIVE • SAUSALITO, CA 94965
(415) 332-5432 • (800) 310-5432**

Fax: (415) 332-8136

**andersonsboat@pacbell.net
www.andersonsboatyard.net**

 Interlux
yachtpaint.com

Duh!

Dead simple. Pure genius!
The release "button" runs the full length of the handle so it locks and unlocks with just one hand.



LEWMAR® OneTouch Winch Handles

The first thing you'll want to do is smack yourself. "Why didn't I think of this?" A OneTouch handle locks-in and releases with just one hand. Pick it up, snick it into the winch socket and start cranking. No more positioning the handle with one hand while you twiddle a finicky little locking switch with the other.

Might as well face it, after trying this handle, old-fashioned lock-in handles are just plain irritating. High strength marine-grade alloy and fiber-filled composite.

Ball bearing single, double and power grips, 10"L. Three-year warranty.



Double Grip \$129.99

Power Grip \$94.99

Single Grip \$89.99

West Marine®
We make boating more fun!®

Find Lewmar OneTouch Winch Handles at our
Alameda Sailing Superstore!
We have 22 stores in Northern California.
Log onto westmarine.com or call 1-800-BOATING
to find the store nearest you.

LETTERS

used for what they intended when they bought them, but for whatever reason didn't get around to it themselves. Just walk down the docks in any marina. The trick is to create a win-win situation, where both parties get something they want.

Another interesting aspect of our trip was the social experiment of two families living on one boat for an extended period of time. I often told people I had two wives, one husband, and three kids. Folks just didn't know what to think — although they were often jealous.

By the way, one of the owner's biggest fears was that we would abandon their boat south of the border, and they would have to deal with getting it back to San Francisco. As it turned out, they so enjoyed having their boat in Mexico that they kept it down there at the end of our travels. She's still down there today. Despite a generational difference in age, we have remained great friends. In fact, we've even become partners in a beautiful property at San Ignacio, Baja.

Pat Conroy
Moss Beach

Pat — We've seen all kinds of variations of what you describe. Walter Flesch, a Dutch captain who does some delivery work for us in the Caribbean, tells us he has different rates for his transatlantic deliveries. "If they want the boat across the ocean quickly, I charge one rate," he says. "But if they let me take my time and enjoy the trip, I charge them a lower rate."

You may remember there was a letter in the January issue by Jorge Ventura who, having delivered a number of hybrid cats over the years, said all the problems had been worked out, and now was the time to support that technology. Perhaps not. The above-mentioned Flesch's latest delivery across the Atlantic was a Lagoon 42 that started out as a hybrid but had been repowered with traditional diesels. It's Walter's understanding that almost all of the Lagoon hybrid cats have been repowered — at enormous expense — with traditional diesels.

↑↓ MORE BOATS THAN EVER UNDER \$60K

My wife and I are in the process of looking for another boat. For six years we've lived and sailed on a '75 Ericson 29 that we outfitted ourselves. We spent two years based out of a marina in San Diego, and four on the hook. One of those years on the hook was in Southern California; the other three were in Mexico. We loved it and are looking forward to getting back to it.

Having sold the Ericson, we are looking for a permanent liveaboard boat. The Ericson had a good turn of speed, was all right at sea, and took a breeze standing up — well, mostly standing up. But we always thought she rolled like an empty beer can at anchor, and she was a lesson in compact living.

Anyway, here are the basics of what we're looking for: a comfortable 30- to 32-footer with a diesel engine, as much tankage as possible, furling and reefing from the cockpit, a propane stove with oven, reasonable comfort, low maintenance, and capable of open ocean sailing. Currently we are looking at both a Gulf 32 and Westsail 32, both of which are cutter rigged. We think we prefer the Gulf 32, as the Westsail seems as though it would feel like living in a cave. Both are heavy, sea-capable boats — the Westsail probably more so, as she doesn't have big windows/ports. Speed? Our Ericson could be pretty quick, but we averaged about four knots over six years, and only put 800 hours on an Atomic 4 gas engine in six years. I don't know if that's good or bad, just that we did it and that we preferred sailing to motoring.

What other boats come to your mind that are under \$60,000? We want to sail the East Coast of the U.S. this time,



MARINA RIVIERA NAYARIT
AT LA CRUZ

the ultimate ... *Marina Experience*

Ask about our
Winter Events & Specials!

Marina Coordinates: Latitude 20°45'N, Longitude 105°24'W

Full Service Marina with up to 400 Vessel Capacity (30-400 ft.), Fuel Station, Pump Out, Dry Dock, 150-ton Travel Lift, Yacht Club, Water, Power, WiFi, Restrooms, Showers, Palapa Restaurant, Sky Bar, First-Class Services and Much More!
And Coming Soon: Hotel Site, Condominiums, Shops,



La Cruz de Huanacastle, Bahía de Banderas, Nayarit, México
Tel (011 52) 329 295 5526
info@marinarivieranayarit.com • www.marinarivieranayarit.com

Relieves Gas Pains

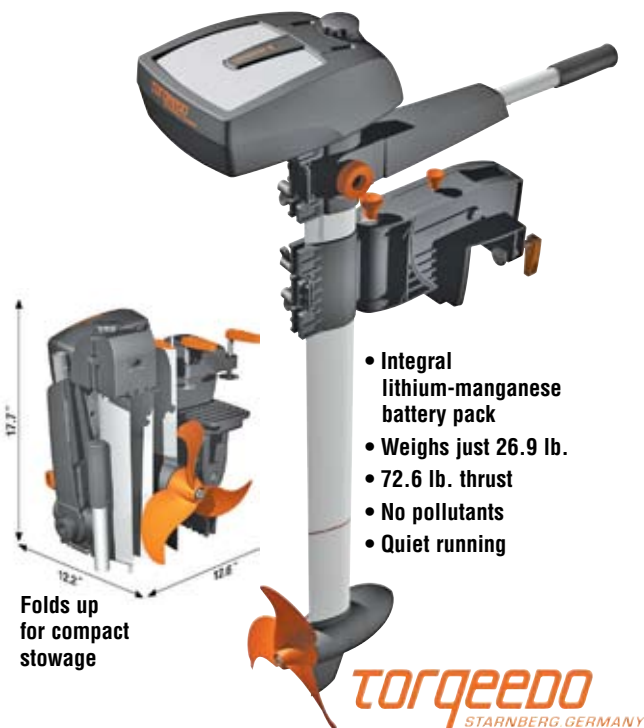

- Integral lithium-manganese battery pack
- Weighs just 26.9 lb.
- 72.6 lb. thrust
- No pollutants
- Quiet running

Folds up for compact stowage

Travel 801 Electric Motor

Finally! A practical alternative to gas-powered outboards that's ideal for tenders, small keelboats and sportboats. The Torqeedo Travel 801 eliminates the mess and potential hazards of gas tanks along with oil changes, tune-ups, fumes and that infernal racket.

The Torqeedo combines an advanced lithium-manganese battery, highly efficient synchronous permanent magnet motor and variable pitch prop to produce thrust equivalent to a 2 hp combustion motor. It weighs a mere 26.9 lb. (with battery) and can be folded for easy stowage and transport.

If you're ready to say good-bye to gas pains, say hello to a better propulsion solution—the Torqeedo Travel 801 Electric Motor.

Long & Short Shaft versions available. **\$1599.00**

West Marine
We make boating more fun!

Find the Torqeedo Travel 801 Electric Motor at our **Alameda Sailing Superstore!**

730 Buena Vista Ave. • 510-521-4865

We have 22 stores in Northern California.

Log onto westmarine.com or call **1-800-BOATING** to find the store nearest you.

LETTERS

as we've seen about all there is of the West Coast and Mexico. Besides, it seems as though the East Coast is maybe a little more boat-friendly. It also has access to the entire Caribbean, the Caribbean coast of Mexico, Central America, and maybe, just maybe, Europe.

So what do you think, the Gulf, the Westsail, something else — or just stay home and take up knitting?

Craig & Celeste Adamson
Phoenix, Arizona

Craig and Celeste — Given that the world is so full of interesting people and places, you know our answer to your last question. By the way, LaDonna Bubak, our Sightings editor, wants you to know that it's not only possible to cruise and knit at the same time, it's also a heck of a lot of fun.

People asking us what boat they should buy is a lot like their asking us which person they should marry. It's all about personal preferences and chemistry. In the case of the Gulf 32 and the Westsail 32, we think you've evaluated them pretty well. The Gulf is going to be less like living in a cave, while the Westsail might be a little more reassuring in very rough conditions. A number of Westsails have done circumnavigations, but we also know of at least two Gulf 32s that have travelled more than halfway around the world.

As for other boats in the under-\$60,000 price range, there are an untold number, and it's certainly a buyer's market, so you can expect to get much more in that price range than you could a year or two ago. Given that situation, and the fact that you are planning to do the Caribbean and maybe Europe, we suggest that you look at slightly larger boats that would still be easy to doublehand. The larger length would tend to mean more comfort on the hook and in rough conditions, as well as more speed under sail.

Happy boat hunting!

IT MAY BE PARADISE BUT IT'S NOT TROPICAL

Your item in the January 7 *'Lectronic* about the surprise cruisers get when they discover that New Zealand isn't tropical nearly made me choke on my morning cuppa. So true! And Auckland is at the northern end of the country. Anyone who bothers to venture farther south — to Tauranga, Wellington, the Abel Tasman, the Marlborough Sound, and some of the other spectacular destinations here — is in for a real shock.

I always roll my eyes when someone from home seems surprised to learn that Christchurch may as well be Oregon for its latitude — but is worse for the crazy maritime climate. I remind them that a thousand-odd of miles of Southern Ocean is all that separates us from Antarctica. Brr!

Sutter Schumacher
Christchurch, New Zealand

I FEEL LIKE THE LUCKIEST MAN IN THE WORLD

I'm about to make my first sail to Mexico — singlehanded — but can't find any information out about how far out the north/south shipping lanes are. I searched for an answer in previous *Latitudes*, but every mention of shipping lanes suggested that everybody knows where they are. This same specific question has been asked on *Wikipedia*, but has not been answered yet.

If I'm not mistaken, the shipping lanes have been moved farther out in order to protect the whales, but I'm unable to find how far out they've been moved. I'm tempted to sail in the most consistent wind, which I figure would be about 50 miles offshore, but fear that would put me directly in harm's way with regard to ships.

THE FINEST SAILS BEGIN WITH THE BEST SAILCLOTH

Our patented woven Vectran® sailcloth performs like the laminates with the durability of Dacron®, especially in roller furling applications. In fact, Vectran® is lighter, lower stretch, and retains its shape over a longer life than any sailcloth we've ever offered to cruising sailors. That's because Hood Vectran® is woven, not laminated to Mylar® film. And you can be sure that each sail we roll out is built by hand, with the same care and craftsmanship that has been the Hood hallmark for 50 years. To discuss your sailcloth needs – whether our state-of-the-art Vectran® or our soft, tight-weave Dacron® – give us a call today.

HOOD Sails & Service

HOOD New Sails

HOOD Sail Repairs

HOOD Furling Conversions

HOOD Pickup & Delivery



SAILMAKERS

*Outbound Yachts
New Outbound 52
with Hood Vektron
Vertical Full Batten
In-Mast Furling
Mainsail and 135%
Vektron Genoa*

PHOTO COURTESY
SWIFTSURE YACHTS

HOOD SAILMAKERS 466 Coloma Street, Sausalito, CA 94965

Call Robin Sodaro (800) 883-7245 (415) 332-4104 Fax (415) 332-0943 hoodsails@aol.com

Visit our website for Special Online Discount Pricing... www.hoodsailmakers.com

Slicker is Quicker



Team McLube Sailkote

Whether you race, cruise or daysail, you know that sailing is more enjoyable when everything works smoothly. That's why so many savvy sailors rely on Team McLube Sailkote to optimize the performance of practically everything aboard. Spray it on sails to repel water and dirt, on hulls to reduce drag and waterline scum, and on sail tracks, traveler cars and blocks to reduce friction and wear. Unlike other silicone, wax, Teflon or petroleum-based lubricants, Sailkote is a dry-film formula that lasts longer and works better in the saltwater environment. Make your boat's systems slicker with Sailkote by Team McLube.

16 oz. Spray **\$16.99**

West Marine
We make boating more fun!

Visit our **Alameda Sailing Superstore!**
730 Buena Vista Ave. • 510-521-4865

We have 22 stores in Northern California.
Log onto westmarine.com or call **1-800-BOATING**
to find the store nearest you.

LETTERS

I'm a shoestring cruiser with a lifelong dream and little else — no radar, no SSB, no self-steering, and a sounding lead for depth. I do, however, have a VHF. But I'm not whining, as my boat is very seaworthy and has many sails. In fact, I feel like the luckiest man in the world to be able to do this. My boat is blessed with twin running sails, which eliminates the need



TONY SMARIO

Tony Smario doesn't want all the gadgets and goodies — he's going simple and going now.

to steer or for self-steering — as long as the wind is from the stern. When I sailed down the California coast in October from Santa Cruz, I had 25-30 knots of wind. But thanks to the twins, it was a breeze, as I didn't have to touch the tiller for three days, and then only because the wind died behind the Channel Islands. I'm hoping for a similar experience going down the coast of Baja.

By the way, I'm a big fan of *Latitude 38* and have been an avid reader for years.

Tony Smario
Two Harbors, Catalina

Tony — The term 'shipping lanes' can be misleading. In some places, namely approaches to big ports such as San Francisco, Los Angeles and Long Beach, and in places where there is somewhat limited water, such as the Santa Barbara Channel, there are actually defined lanes. You can find these on your charts.

To our knowledge, there are no 'lanes' that have been established to protect whales from ships, but ships do have to stay a certain distance off the coast of California — it's not that far — in case there is an oil spill.

The term 'shipping lane' also loosely refers to routes commonly taken by a large number of ships. For example, all the ships heading from the Panama Canal to ports on the west coast of Mexico, the United States and Canada pretty much follow the same route, which is pretty much hugging the coast the entire way because it's the shortest route. That's why the Ha-Ha fleet crosses paths with so many ships each year. However, you'd be wrong to assume that ships always take the shortest route between two ports. For example, ships making runs between Japan and the U.S. often vary their routes tremendously, particularly in winter, because of weather concerns.

The bottom line is that ships can and do go anywhere they want, except for a few well-defined areas, where they have to follow certain rules. But the farther offshore you go, the less likely you are to encounter ships. Most offshore sailors breathe a sigh of relief once they get 50 to 100 miles offshore. If you do find some spare cash, you might want to equip yourself with an AIS B system, so you can set the alarm to indicate the approach of any large ships. If you have radar, you can set the alarm for that also, although it's not as effective in rain and sloppy seas.

Don't have a SSB, radar or self-steering, and you'll be using a lead line for a depthsounder? Don't worry about it, as you — particularly with your attitude — can do just fine with all that stuff. We twice had a stock Olson 30 in Mexico and had a

www.creation-base.com







Hanse 

470e

320 350 370* 400* 430 540e 630e
NEW NEW

*epoxy option

INNOVATION - SPEED - COMFORT

-  Ground breaking interior design
-  Multiple layout options (Individual Cabin Concept)
-  Modern, award winning performance cruisers
-  Self-tacking jib engineered into the HanseYachts design
-  Epoxy hulls (option up to 43 ft)
-  Safe, comfortable, fast & easy to sail

YOUR NEW WORLD LIES ON THE WATER

Hanse Yachts US

Ph: 1 - 410 - 626 - 1493

dwalsh@hanseyachts.com

www.hanseyachts.com



VALLEJO MARINA



Gateway To The Bay & Delta

Join us! We love making new friends and spoiling them!



48-ft. BERTHS NOW AVAILABLE

- Competitive Rates!
- Great Restrooms with Showers
- Ample Guest Dock
- Full Service Boat Yard and Chandlery
- FREE Pump Out Stations
- Fuel Dock
- 2 Restaurants for Breakfast, Lunch, Cocktails and Dinner
- Covered and Open Berths
- Launch Ramp
- Ferry Service to San Francisco

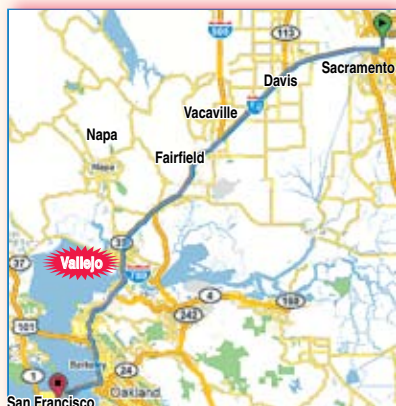

- One hour from Sacramento
- Only Three hours from Reno
- Easy access to San Francisco Bay and the Delta

(707) 648-4370

Fax 707-648-4660

42 Harbor Way • Vallejo, CA 94590

www.ci.vallejo.ca.us

LETTERS

blast with her . . . at least until we blew out a disc as a result of being scrunched over from the lack of headroom.

Thanks for the kind words — and don't forget to send a report on your trip.

↑↓ THE #1 REASON FOLKS GIVE UP CRUISING

Per the discussion surrounding "Cruisers' Remorse," let me give a hearty second to *Latitude's* suggestion that people keep their boats simple so the maintenance and repairs don't become overwhelming. In my 30+ years of cruising, I've come to the conclusion that the Number One factor in people's giving up cruising — other than those who have to leave because of illness, family, or finances — is the constant work, expense and hassle involved with fixing their boat.

The funny thing is, the newer the boat, the worse the problems seem to be — probably because systems have gotten so much more complicated. Even if something is under warranty, it often leads to long delays and huge hassles while parts are secured or repairs are made by supposed professionals. In fact, in many cases, the repair job is botched, leading to further issues.

To enjoy cruising, you really have to be able to fix almost anything yourself and/or oversee the work that is being performed. In fact, you somehow either need to enjoy it or at least don't let it get you down. It really is true that cruising is simply taking care of a series of repair jobs in exotic ports around the world.

John J. Kettlewell
Minke, Finnsailer 38
Saratoga Springs, NY

John — Maintenance and repairs certainly are a fact of life when cruising, and for those without a basic knowledge of electrical systems, engines, and plumbing — and we include ourselves among them — they are an even bigger fact of life. For folks like us, less stuff can indeed be more fun.

As for repair problems with new boats, there is just no telling. We know of people who have circumnavigated with complicated boats considered to be second-tier quality — and they had almost no problems. On the other hand, we know people who have bought the best of the best brand boats, and it took the better part of a year to get them completely sorted out.

↑↓ FALCON'S RIG WAS IN LATITUDE 38 YEARS AGO!

Like all of us, I was excited to see *Maltese Falcon* sailing on the Bay this fall — although I wasn't impressed by what I found to be her ultra-unattractive instrument holder on the bow. However, I do think it's time for the talk about her rig's being revolutionary to be exposed as false. For when I read page 73 of the February 1980 issue of *Latitude 38*, I see where Perkins surely got the idea for his boat. Yet I've never seen any credit given to *Latitude* for the development of the rig.

By the way, it was great looking back through that nearly 30-year-old issue. I'd saved it in an old box because of the article about the "interesting adventure" on Bill Clute's Peterson 41 *High Noon* during the 1980 SORC. But I was struck by something else, too — the ad for Pineapple Sails being on page 3, the same place it is today. In addition, City Yachts had their full page ad — actually, 1.5 pages, just like today.

Anyway, hopefully Tom Perkins sent you a thank you card this holiday season, and perhaps Pineapple Sails and City Yachts got something special in their stockings.

Chris Boome
Geezer, Laser
San Carlos

GARHAUER

MARINE HARDWARE

*GREAT
GEAR*

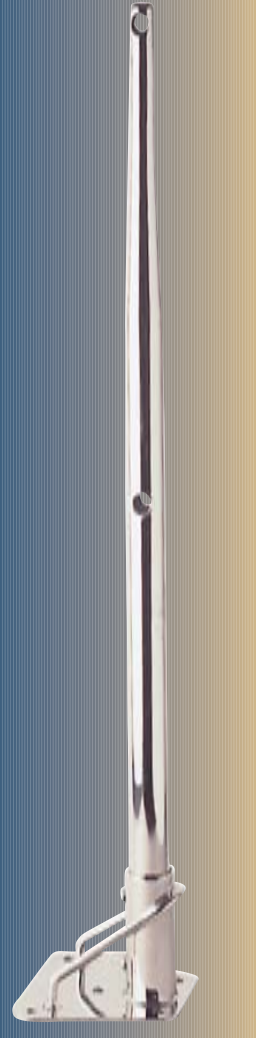

Quality stanchions and gates from Garhauer

Whether you are replacing one stanchion or upgrading your entire boat, we manufacture a complete line of stanchions, bases and gates.

- Stanchion tubes available in 3 different tip styles
- Stanchions and gates can be made removable or with fixed bases.



GARHAUER
MARINE HARDWARE

1082 West Ninth Street,
Upland, California 91786

Phone: (909) 985-9993
FAX: (909) 946-3913

email: garhauer@garhauermarine.com
<http://www.garhauermarine.com>



C. SHERMAN JOHNSON CO. INC.
Johnson
Marine Hardware

KEEPING YOU CONNECTED FOR 50 YEARS!

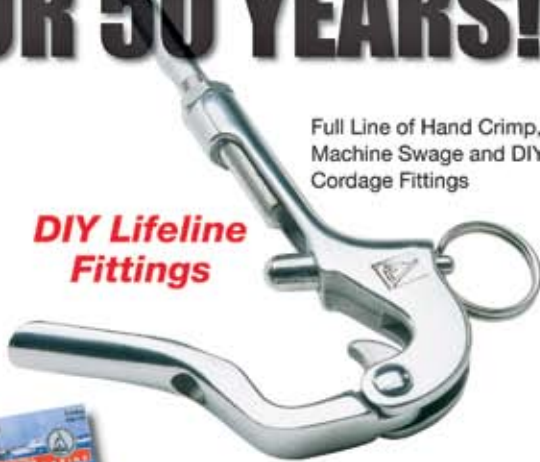

Full Line of Hand Crimp,
Machine Swage and DIY
Cordage Fittings

**DIY Lifeline
Fittings**



**Unique
Accessories**

Grab 'n Go™ Hook

**Rigging
Hardware**



Calibrated
Turnbuckle



C. Sherman Johnson Co., Inc.
East Haddam, CT
1-860-873-8697

www.csjohnson.com

LETTERS

Chris — It might've had something to do with the fact that it ran 28 years ago, but we'd totally forgotten the piece we'd run about the proposed 526-ft Dynaship, which was a cargo ship to be powered by the sails on six rotating wing masts — exactly as on Perkins' Maltese Falcon. We also reported that William Warner of Palo Alto was the president of Dynaship, which had purchased the patent rights from a German-owned company. An interesting feature of the proposed design was that it was to have 16-ft daggerboards at the bow and stern. The proposed ship was never built.

When Perkins began to think about buying the already built 289-ft hull that was to become Maltese Falcon, it was



LATITUDE / LADONNA

the Amsterdam-based naval architect Gerry Dijkstra who proposed the idea of fitting Falcon with a Dyna-Rig. The scientist in Perkins was intrigued enough to acquire the rights to the Dyna-Rig technology, then spend \$10 million over a period of about two years to see if the theoretical rig would work in practice. It wasn't until they got a very small version of a Dyna-

Back to the future — We'd long forgotten that 'Latitude' wrote about the revolutionary Dyna-Rig way back in 1980.

Rigged boat to sail in the canals of Amsterdam that Perkins committed the real money necessary to build the boat.

While the Dyna-Rig technology had been developed in the '70s, it had never been perfected or employed on a yacht or ship. Maltese Falcon was the first. Perkins says it hadn't been technologically possible until the development of carbon fiber for the masts — the original idea of building them in steel wouldn't have worked because they couldn't have taken the repeated stress.

Is the world now ready for ships powered by Dyna-Rigs? Perkins says they still don't make economic sense on commercial vessels.

For those who weren't around 28 years ago, the SORC stood for the Southern Ocean Racing Conference, which was held in the waters off Florida and the Bahamas each winter. Back then it, along with the Admiral's Cup in England, was the premiere offshore racing series in the world. We bumped into High Noon's owner Bill Clute in a Tiburon sushi bar a few months ago, and were glad to see he was doing well. Two winters before, we'd bumped into Donny Anderson, Clute's old captain, who was running Jimmy Buffett's motoryacht Continental Drifter in the Caribbean and the Northeast.

As for Pineapple Sails, they are the only advertiser who has run the same size ad in the same place for the entire history of Latitude. We thank them immensely.

↑↓ A SELF-DESCRIBED 'NUTCASE'

I'm writing in regard to the letter by Bob Young in the December Latitude. As a dyed-in-the-wool Horstman trimaran nutcase — I've owned three of the beasts so far — I always have my 'Tri Star radar' on.

Since '82, I've scoured the West Coast looking for my 'next

Making green sense!



Introducing our Festool Cleantec vacuum sander, designed to save you time and money while protecting the environment. We use it, and we also make it available for do-it-yourself projects. At the nominal fee of \$15/day (or \$7.50/half day), you'll save hours, even days of sanding, spend less in sanding materials, and be kinder to yourself and the environment. Sometimes it isn't so hard to be green!

Ask us about the many ways we can make our yard work for you!

**Chandlery &
Fuel Dock
Open 7 Days**

Mon – Fri
8 am to 5 pm
Sat & Sun
9 am to 5 pm



Lift capacity 35 tons

Sprayed Racing Bottoms
Full Painting Service
Fiberglass & Gelcoat Repairs
Rigging Repairs & Installation
Electrical Repairs & Installation
Engine Service & Repowering
Propeller Installation & Tuning
Wood Hull Repairs & Caulking
Teak & Non-Skid Deck Repairs

We feature
Seahawk
Antifouling
Bottom Paint



**A high-performing,
environmentally friendly
bottom paint!**

(see details on our website)

In Berkeley Marina • 510-843-8195 • www.berkeleymarine.com



South Beach Harbor is a great way to experience San Francisco. Boats of all sizes are welcome in our protected deepwater harbor. Bring your boat to South Beach and enjoy all the attractions of the city.



- Two guest docks for boats up to 125'**
- 20 guest berths up to 50'**
- Casual and fine dining nearby**
- Adjacent to AT&T Park**
- Easy access to transportation**
- 24 hour security**
- Free pump-out stations**



For Reservations:
 415.495.4911 (x0)
 fax: 415.512.1351
 sb.harbor@sfgov.org
 www.southbeachharbor.com

LETTERS

one', and clearly recall the trimaran building frenzy in Milpitas-Alviso nearly 30 years ago. There were trimarans all over the place, including some sitting bow down in the mud and marshgrass, with cobbled-together gangplanks extending out to them from the banks.

I don't recall seeing the tri Young describes in Alviso, but there was a 60-ft or so tri at the docks in Sausalito in the '80s named *My Way*. She was distinctive for her series of rectangular windows in the amas — six in a row, as I recall. She appeared to have been very nicely done, but I have no idea of her history or where she went.

Is Young sure he is talking about a 60? There was a 48-footer in Nanaimo, Canada, for sale about 10 years ago.

As for myself, I started with a 30, moved up to a 41, and now sail a 39-footer, the former *Puffin* now named *Crossroads*. Love those Horstmans!

Thom Wessels
Crossroads, Horstman 39 Tri Star
 Long Beach

↑↓ A HOT-BLOODED SICILIAN WHO LOVES HIS SPEEDO

I wanna get my buns in print, so here's a full size photo of me mending my Speedo, and another photo of me wearing the finished result.

Even though I'm a *norteamericano*, I have hot Sicilian blood gushing through my veins, and like my European brethren,



love Speedos. When wearing one, you can almost feel naked all the time — even at dinner parties with friends.

You know what else I'd like? To get a date with Liz Clark. Can you help?

If anyone is interested, I own *Little Bird*, my beloved Hobie 21 beach cat with wings that I sail off Capitola Beach. I think my cat is one of the fastest and scariest rides on Monterey Bay. I can usually keep the mast up, although I have capsized twice. Once

I flipped her with my buddy Pete in the kelp beds next to the wharf, and then another time during a desperate yet blissful singlehanded reach somewhere near the cement ship. The first time I was rescued by the Capitola Pier harbormaster, the second time by the Santa Cruz Harbor Patrol. Bless their hearts, for without them, I'd have had a shortened stick upon impact with the shorebreak.

But if anyone is interested in foolin' around on *Little Bird* with me next summer, they know where to find me.

Vince Pastore
Little Bird, Hobie 21
 Capitola

Vince — Sorry, but we don't arrange dates. Besides, if you'd kept up your reading, you'd know that Speedos are one of the few things that really gross Liz out. She finds them disgusting. Speedos, of course, are ubiquitous in Europe, even among the cool. If the French see you wearing a pair of California baggies when not surfing, they think you're an idiot. They wonder why you don't just wear a pair of jeans in the ocean, something that has inexplicably been popular with locals in Mexico.

South Beach Sailing Center

*Design, Fine Yacht Upholstery,
Fabrication, Etc.*

WINNER!
2008 IFAI International
Achievement Award



YACHT: LIN MAR

**NORTH
BEACH
MARINE
CANVAS**

415.543.1887

nbmc@earthlink.net

www.northbeachmarinecanvas.com

Pier 40, The Embarcadero
South Beach Harbor, San Francisco

South Beach Riggers

Don't let your
winches grind
you down...

**25%
OFF***

Winch Servicing,
Parts and Labor
Call Tom today!

*Offer expires
February 28, 2009.



TWO LOCATIONS

399 Harbor Dr. • Clipper Marina • Sausalito • 415.331.3400
Pier 40 • South Beach Harbor • San Francisco • 415.974.6063

**CAL MARINE
ELECTRONICS**

**Ryan's
Marine**

Fall and winter is the ideal time
for that **ELECTRONICS** or
ELECTRICAL upgrade

Competitive Rates ... Top Quality ... Complete Offering

- Radars
- VHF Radios
- GPS
- AIS
- Auto Pilots
- Instrumentation
- Chartplotters
- HF / SSB / Ham
- Inverters
- Batteries
- Charging Systems
- Alternator Packages



Call today for a quote

415-391-7550
510-385-3842

fred@calmarineelectronics.com rssailor@yahoo.com

The difference between a boat and a yacht



- Mobile Service:
We Deliver!
- Washing
- Waxing
- Varnishing
- Interior Cleaning

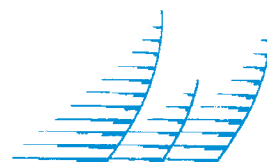

Westwind

Complete Yacht Care

*Serving the entire Bay Area for
more than 20 years*



(415) 661-2205

Pier 40, South Beach on the Embarcadero • San Francisco

Call Toll Free **888-828-6789**

westwinddetailing@sonic.net
www.boatdetailing.com



Pier 40 • South Beach Harbor • San Francisco

LETTERS

For the record, Speedos — aka 'budgie smugglers' and 'banana slings' — originated on Bondi Beach, Australia, in 1928. The appeal has always been that they dry quickly when you get out of the water — and that they can double as underwear.



COURTESY LITTLE BIRD

But this shot should get any red-blooded sailor chick's heart a-thumpin'.

Liz is entitled to her opinion on the aesthetics of Speedos, but we believe they are wonderfully functional cruising attire for men who frankly don't give a dang what others think of their comfort wear. If you have to bring a dinghy through the surf, you strip down to your Speedo, keeping your shorts in a dry place. Once you've made it through the surf and your Speedo has dried off, you put your shorts back on. Speedos — albeit only the black ones

— were once so common with cruisers in Mexico that they were dubbed 'Baja Tuxedos'.

While the Speedo won't get you very far with most modern women, Vince, the picture of you at the sewing machine is almost certain to make most women weak in the knees. According to surveys in women's magazines, the only thing more certain to turn women on than Brad Pitt in the buff is a guy — and almost any guy will do — washing dishes. Freud could never figure out what it is that women really wanted, but it's simple — help with domestic chores.

↑↓ THE LOVE FOR THE HA-HA SHOWS

The Grand Poobah and Ha-Ha staff have an obvious love for that event, and the folks on our boat want to say we had a fine time — even though we missed the Downwind Marine and West Marine Ha-Ha parties just before the start of the event, and the Ha-Ha party at Bahia Santa Maria. The latter was because we had to start a day early to take our crew to Cabo because of a family emergency. But we loved the closing ceremony in Cabo — very well done. It left us with a fine feeling for the event.

Bill Houlihan
Sun Baby, Lagoon 41
San Diego

Bill — Thanks for the kind words. We received many letters of appreciation for last year's Ha-Ha, but just don't have the space to run them all. But what a great group of sailors.

Yes, we love the Ha-Ha, and are already looking forward to the Sweet Sixteen version that will leave from San Diego on October 26. By the way, in response to popular demand, we've scheduled a full moon for November 2, right in the middle of the Ha-Ha.

↑↓ COMING FROM OZ TO DO THE HA-HA

I just came across the *Latitude* website, and I have to say — what a find! As I'm from Australia, we don't get a lot of information about cruising in the Sea of Cortez. My family and I wish to enter the '09 Ha-Ha, but we need to know the best place to find a good secondhand boat in the 40- to 48-ft range. The West Coast, East Coast or Mexico, it makes no difference to us where we buy her. We plan to visit La Paz and Puerto Vallarta in March of this year to start our search.

Warren Neate
Down Under

SAIL TO OUR NEW MARINA

Great Long-Term Lease Deals Jan & Feb 2009

- electricity
- deli facilities
- fire fighting system
- waste disposal
- fuel dock
- 24/7 security
- wi-fi

LAT. 20°41'22"N • LONG 105°17'28"W



WWW.MARINANUEVOVALLARTA.COM

MONITORING VHF 16

PH: 52 (322) 29 77 000

HARBOR MASTER: JUAN S. ESTRADA

JUAN@MARINANUEVOVALLARTA.COM



Engineering to Win

Doyle designs have proven themselves with big victories. White Dove dominated the season winning the 2008 SF-IRC season, Aldo Alessio Regatta, the West Coast IRC Championship, and a Rolex for their class win in the St. Francis Yacht Club's Rolex Big Boat Series. Join the revolution! Contact your local Doyle loft.

Authorized Dealers for



doylesails.com

Doyle San Francisco

Bill Colombo & Rusty Canada

510-523-9411

sanfrancisco@doylesails.com

800-94-DOYLE

BETTER ENGINEERED SAILS

Sausalito Yacht Club

Est. 1942 • A Bay Area Tradition

Join Sausalito Yacht Club in 2009 Special!

Get ready for Opening Day

ENJOY

- Informal, relaxed ambiance
- Superb galley and bar, all professionally staffed
- Outside bar and patio with a great view
- Cozy fireplace
- Mooring buoys as well as guest dock
- Reciprocal privileges at yacht clubs worldwide
- Very active in Club cruises – every month to various destinations – sail or power with your fellow Club members
- Extensive social calendar
- Tuesday Night Races and other sailing (Ask about Under 35 Racing Membership)
- Excellent Junior Sailing Program

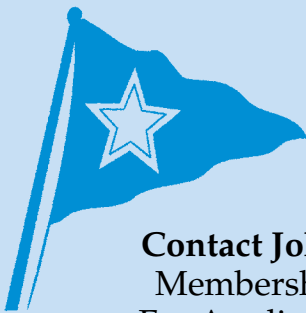

Contact John Lerner
Membership Chair
For Applications and
One Day Guest Pass

Sausalito Yacht Club
P.O. Box 267
Sausalito, CA 94966

Call (415) 332-7400 ext. 412
membership@sausalitoyachtclub.org
www.sausalitoyachtclub.org

LETTERS

Warren — *If you want to do the Ha-Ha, there are legions of suitable boats in your size range from the Pacific Northwest to Mexico. You're sure to find what you want, and at a good price, too. By the way, if you're into Ha-Ha type fun, make sure you and your family get on a boat in the Banderas Bay Regatta, which is a terrific 'nothing serious' event for cruisers only.*

Interesting fact: For many years the average size of an entry in the Ha-Ha has been about 43 feet.

↑↓AS A RETIRED COP, I FEEL DISGRACED

The following is my message to the State Attorney General's Office regarding the Bismarck Dinius case:

It would seem to me that a simpleton could understand that a person driving a boat at a high rate of speed in the dark while under the influence would eventually hit something. Unfortunately, in this case the person, Deputy Perdock, not only hit something, but by doing so, caused the death of an innocent woman. It seems that Perdock was lucky to be a law officer because, according to all the information I've heard about from Lake County, fellow law enforcement officials have found someone else, Bismarck Dinius, to blame for his recklessness.

Having been a California State Police Officer, I feel disgraced by the actions of the Lake County District Attorney's Office in this case. It appears to me that someone made a decision to cover for Officer Perdock, and now there is no way of backing out — without either admitting their stupidity or their flagrant disregard for the law.

To do the proper thing, the Lake County District Attorney's Office needs to drop the charges against Dinius, a man who was merely sitting at the helm of a drifting sailboat when it was hit by Perdock at high speed. Then the District Attorney's Office needs to formulate new charges — the ones that should have been filed in the first place — against Deputy Perdock, and make a formal apology to the citizens of Lake County and the boating public in general. They should also file charges against the officer(s) who drove Perdock around, which I believe is called aiding and abetting. Lastly, charges should be brought against the Lake County District Attorney's Office and all other parties involved with the handling of this case.

Robert L. Walker
Grace, Traveller 32
Grass Valley

Robert — *While we agree with almost all of your letter, there is no proof that Perdock was under the influence of alcohol or drugs. There are, however, questions about why he wasn't tested for several hours, and some suspect that the results were falsified, but there is no hard evidence.*

↑↓HUMAN TRAFFICKING IN MALTA IS OVERWHELMING

I just read Roger England's letter, in which he mentioned not seeing any people trafficking in the Adriatic area. We live in Vibo Valentia, Calabria, Italy, and just came up from Malta. As such, I can report that human trafficking to Malta and Lampedusa is mind-boggling. Just this month alone, Lampedusa received 1,800 assorted souls. And scores are found washed up on the beaches from Potzzalo, which is at the southern tip of Sicily, all the way to Reggio di Calabria and beyond. Human trafficking is as lucrative as drug running. Malta is now labeled as the largest recipient, per capita, of victims of human trafficking in Europe. It's overwhelming.

Nick Borg
Captain Pepper, Panda 33
Vibo Valentia, Italy



Baja Sur

Jacques Cousteau considered the Sea of Cortés the world's largest aquarium. Come view it from within.



The Sea of Cortés is not only winter home to the grey whales, it has more marlin than any area of the world as well as thousands of other colorful creatures that are *not* to be observed from afar. So, to get an up-close view, and to experience the adventure of this unique environment, just dock your vessel at any one of the four superb marinas in La Paz and, at your leisure, wander the streets and byways of this picturesque town, cruise to the fishing grounds, or explore a quiet island, cove or inlet. Then as Mr. Cousteau preferred, jump right into the aquarium. You'll never feel so alive.

For more information visit:
marinacostabaja.com; marinadelapaz.com;
marinapalmira.com; clubcantamar.com

México
BEYOND YOUR EXPECTATIONS

Come Explore the Richness of Baja Sur.

Baja California Sur

mybajasur.com

| 877 MY BAJA SUR

There's a new way to
install electronics.
A more efficient way.
The ServiceShip™ way.



Imagine sitting with one of our ABYC & NMMA certified technicians and you're planning the installation of your new electronic package. A question comes up, "How will the display look on the boat?". With our new ServiceShip, all you do is walk a few feet onto the dock where your boat is tied up and take a look. Simple. So too is the time it takes to service and install the equipment.

Time is money.

With the ServiceShip, none goes to waste.



530 West Cutting Blvd. * Pt. Richmond, CA 94804
Office (510) 235-5564 * Chandlery (510) 237-4141
email yard@kkmi.com * visit www.kkmi.com

LETTERS

Nick — According to a four-part series by Meredith May in the San Francisco Chronicle about 18 months ago, San Francisco is also a major center of human sex trafficking:

"Once limited to infamous locales such as Bombay and Bangkok, sex trafficking is now an \$8 billion international business, with San Francisco among its largest commercial centers. San Francisco's liberal attitude toward sex, the city's history of arresting prostitutes instead of pimps, and its large immigrant population have made it one of the top American cities for international sex traffickers to do business undetected, according to Donna Hughes, a national expert on sex trafficking at the University of Rhode Island."

Most victims of sex trafficking are kept "deep underground," so unless a resident of San Francisco visits an Asian massage parlor, he/she would be unlikely to encounter such a victim. Interestingly, the website www.myredbook.com, which posts consumer reviews of sex workers and sex businesses, and therefore is one of the police department's main insights into the business, indicates that there are at least 90 massage parlors in San Francisco where sex is offered for sale. Of these, 37 are licensed as legal massage parlors by the San Francisco Department of Health.

As a reminder, the whole sex trafficking topic came up when we ran some photos of cruiser Andrew Vik of the *Islander 36* Geja in Croatia partying with some girls who looked like typical girls from Marin County. We think the chances that those women were victims of sex trafficking are about nil.

↑↓ MIK BEATIE WAS ONE OF A KIND

I was saddened to hear about the passing of Mik Beatie. I first met him at the Richmond YC back in the '80s when he owned the *Express 27 Beth!*, and his son Hogan, now a big time sailor, was in the junior program. Mik's wife Suzy had a long history with the club, as her dad had been a past commodore. I still remember thinking they were the coolest married couple I knew. In an age of divorce and unhappy relationships, Mik and Suzy always seemed happy.

I heard only a few of Mik's old war stories from his *Windward Passage* days, so most of my sailing memories of him involved sailing against or with him. Once I looked back to see *Beth!* go into a spectacular broach — throwing Mik right off the boat! We later learned that happened a lot. But back at the dock there were never dampened spirits, just big laughs.

Several years later, I got to sail with Mik. He was short one crew and I was the only one around with the right qualification: my name was Steve — the same as his two other crew. We had a few close calls, but nobody went swimming that day.

Years later I was sailing with Walt Logan on his Farr 40 *Blue Chip*. We were sailing north to the Richmond Bridge when we looked behind — and were startled to see a Larkspur Ferry coming up our transom at a high rate of speed! Then we heard the big booming laugh and saw the big smile on the face of the captain — it was Mik, taking the new ferry out on a trial run. He was one of a kind.

Steve Bates
Wind Blown Hare, Wylie Wabbit
Richmond YC

↑↓ STOW SOY SAUCE IN THE GALLEY AND MED KIT

I read with interest the December letter from Heather Corsaro regarding stingray wounds and various remedies for stings and burns. I listen to National Public Radio a lot, and they have one program about health and home remedies. For burns, one listener suggested a thorough soaking in soy

Why settle?



Ballena Isle Marina

Alameda 510.523.5528

Jack London Marina

Oakland 510.834.4591

Treasure Island Marina

San Francisco 415.981.2416

Martinez Marina

Martinez 925.313.0942

You don't settle for less, why do it with your marina? Join one Almar marina and gain access to seven Bay Area marinas. Almar's reciprocal program takes the hassle out of your boating weekend. A simple call to the marina office and you can spend the weekend at Jack London Square or Treasure Island. Maybe a trip to a few of Almar's seven Southern California marinas. We make it so easy you may find yourself using your boat.

Almar boaters receive a 10% discount on any fuel purchase at Jack London Square and Ballena Isle Marina. Jack London Square Marina has just upgraded it's fuel dock with high speed fuel dispensers and now has the fastest pumps in the Bay Area. You don't have to settle anymore.

Almar is the largest operator of saltwater marinas in the country. Almar Marinas provide a wide range of services and programs that few marinas or yacht clubs offer. Some of these programs include: monthly boating seminars, boat handling classes, navigation courses and organized outings to local anchorages. Each marina offers wireless high speed internet access, which can be used with your reciprocal privileges at any Almar Marina. To see the difference, visit one of our marinas this weekend.



almar.com

ISLAND YACHT CLUB

Located adjacent to Svendsen's Marine in the Alameda Marina
1853 Clement Avenue
www.iyc.org • (510) 521-2980

SIGN UP!

28TH Annual DOUBLEHANDED LIGHTSHIP RACE Saturday, March 14

- Ease into the ocean racing season with us
 - Ride the flood home
 - Only two mouths to feed

Benefits United Cerebral Palsy

SADIE HAWKINS RACE February 28

Part of the Bay Women's Circuit

Warm, flat water racing in the Estuary

Woman Skipper • Full Crew

Chowder Challenge; followed by
Adam Sadeg, Svendsen's Marine, to talk
on managing boat repairs and rigging.

SAVE THE DATES!

2009 Silver Eagle 🍷 July 11

Watch for new courses!

Friday Nights 🍷 April-September



For information, email
iycracing@yahoo.com
or call

Race Chair John New (510) 521-7442

LETTERS

sauce. It struck me as very interesting, so I remembered it.

As luck would have it, about three weeks later I was making coffee in the cockpit of my boat when I accidentally hit the handle of a small pan of boiling water. As a result, some of the boiling water splashed on the top of my right hand. Remembering the NPR program, I grabbed the Kikkoman soy sauce from my galley supply, and generously applied it to the scalded skin. I then soaked a bandage with soy sauce and applied it to the burned area — as had been recommended.

In about 10 minutes the burning sensation was relieved by almost 90%. When I removed the soaking bandage the following morning, the skin on my hand was a little red, but I had no blisters and felt no pain. I don't know what's in soy sauce to do what it does, but I'm a true believer in its medicinal qualities.

I love soy sauce, but now I keep an extra large bottle on-board just in case there are any burn incidents. Unfortunately, soy sauce doesn't work on chemical burns. But I thought I'd mention it as we — no pun intended — all get burned once in a while.

Dana Vincent
*Gladys Erzella, Cape Dory 25
San Diego Bay*

Dana — We don't know about soy sauce's being good for



burns, but we do know your letter has made us salivate for two orders of saba, two of hamachi, and two spicy tuna rolls.

As for the sting-ray wound on David's heel, we saw it about a month later when it looked like this. It appeared to

My, isn't that healing nicely?

be a prime candidate for a nasty staph infection, but he left it the way it was.

👁️ **LOOKING FOR A PHOTO OF SEARUNNER**

I lived aboard in Monterey for three years in the early '80s, and there was a gorgeous wooden boat in the marina called *SeaRunner*. She was owned by Bill Bacon, a then-elderly man who had circumnavigated with her once — if not twice. Even in his late 70s, Bacon was very popular with the attractive young ladies, for he served fine dinners aboard his beautiful boat.

SeaRunner was very sleek, like a miniature meter boat, and about 36 feet on deck but with long overhangs. She was built of spruce and had lots of yellow-gold colored brightwork. She was perhaps the prettiest boat I've ever seen, and Bacon kept her in immaculate condition.

I'm wondering if you have any photos of *SeaRunner* from your early issues. I tried a search, but didn't have any luck. However, I do know that she was one of two boats that were built at the same time in the '30s. The other boat is either in Santa Barbara or in Morro Bay.

I lived and sailed on *Aldens*, both originals and copies, with the wooden boat contingent in Monterey. Those folks were such great company. Folks like Steve Gann with his immaculate *Vim*, winner of her class several times in the Master Mariners Regattas. The early '80s were a good era in Monterey. I'm sure that a mooring costs an arm and a leg now, but back then you could get one for \$50 a month.



HAULOUTS 20' to 80'

HAULOUTS ON SHORT NOTICE...CALL US!



PHOTO: LATITUDE 38/JR

NORTHERN LIGHTS

GENERATOR SALES & SERVICE

WUGGER

MARINE ENGINES SALES & SERVICE

YOUR NEW FULL SERVICE
VOLVO PENTA
DEALER IN THE BAY AREA

PETTIT
marine paint

Sea Hawk
PREMIUM YACHT FINISHES

FULL SERVICE BOATYARD:

- ✓ COMPLETE PROPELLER SHOP
- ✓ ELECTRICAL REPAIR & INSTALLATION
- ✓ FIBERGLASS BLISTER WORK
- ✓ LPU PAINTING
- ✓ COMPLETE MACHINE SHOP
- ✓ SHIPWRIGHTS - CAULKING & CARPENTRY
- ✓ GAS & DIESEL ENGINE SERVICE
- ✓ MAST & RIGGING REPAIR
- ✓ SANDBLASTING & EPOXY COATINGS
- ✓ FIBERGLASS & GELCOAT REPAIRS
- ✓ USCG CERT. WELDERS - STEEL/ALUMINUM
- ✓ INSURANCE WORK WELCOME

88-TON TRAVELIFT HANDLES UP TO 23' BEAM!

Online reservations now available at www.baymarineboatworks.com

BAY DESIGN & ENGINEERING

1-800-900-6646
(510) 237-0140 • Fax: (510) 237-2253

STEVE TAFT, MANAGER
310 WEST CUTTING BLVD. • POINT RICHMOND, CA 94804

BAY PROPELLER
COMPLETE PROPELLER SERVICE

ALAMEDA'S FINEST SLIPS AVAILABLE AT



PEACEFUL, PROTECTED FIRST-CLASS YACHT HARBOR

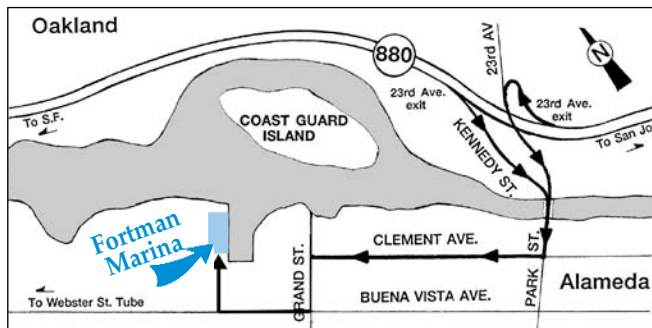

- Sheltered Alameda Location
- Competitive Rates
- Home of the Alameda Yacht Club

1535 Buena Vista Ave., Alameda, California
(510) 522-9080

For directions and rates go to:
www.fortman.com

LETTERS

I've been living in Tahoe since '89. Sometimes I buy sandwiches up here at Yellow Subs, which always has issues of *Latitude*. Looking through those pages makes me homesick for



COURTESY CITY OF MONTEREY

the good old days in Monterey. *Latitude* is a wonderful magazine — may she live forever!

John Harrod
Lake Tahoe

John —
Thanks for the kind comments. Sorry, but we don't remember SeaRunner. That

Mooring rates in Monterey haven't gone up that much in the last 20 years.

was still in the relatively early days of the magazine, so we may have missed her and the exploits of her owner. But there must be somebody out there in our readership who remembers such a boat. If you do, email richard@latitude38.com.

For the record, moorings at Monterey now go for \$110 per month for a 30- to 40-ft boat.

PRICE GOUGING IS NOT A SMART MOVE

You guys are killing me with the photos of St. Barth in *Lectronic Latitude*. It's the wind and the color of the water that I miss most about the Caribbean. Well, those things and the fact that people there don't act their age.

We're hoping to get down the coast of Mexico and Central America quickly to Panama, then on to the Caribbean. With some luck and continued health on the part of parents, we hope to be in St. Barth next December. Even if we don't make it that soon, we'll feel damned fortunate.

By the way, we think it's great that *Latitude* keeps encouraging people to go out and use their boats during these tough economic times. I understand it's good for your advertisers, but it's probably most important for the mental health of sailors.

Greg Dorland & Debbie Macrorie
Escapade, Catana 52
Lake Tahoe

Greg and Debbie — We agree that going sailing, even in the middle of the winter, is great for clearing your head and getting a better perspective on things. And since most boatowners are already paying for their boat, berth and insurance, it's not like it's going to cost them much extra to use their boats more. Besides, as one sailing doctor recently told us, boats are like sex organs — if you don't use them frequently, they stop working like they are supposed to.

As for St. Barth, we just moved aboard our boat in *Gustavia* last week, and love it, love it, love it. What we don't love is that the powers that be on the little island seem to have lost their minds when it comes to anchoring fees. Despite 200 fewer boats showing up for New Year's, and villa occupancy down 40% over the holidays, the local government has seen fit to jack up the rates. For example, they are now charging US\$900 a month for a 45-ft cat, such as ours, to have the privilege of anchoring anywhere around the island. We love all our friends here, and we love the island, but this is something like a 70% increase this year on top of something like a 30% increase last year. It's something we can't accept on principle. Either they rescind most of the increase or we — and we suspect many

TURKISH TREASURE!

SEPT. 2-14, 2009 CHARTER TRIP



Join us on a sailing adventure of truly historic proportions. From cliff-lined shores to ancient tombs to crystal-clear warm waters, this is truly a one-of-a-kind sailing adventure in an exotic land. Favorable warm breezes and permanent sunshine make sailing Turkey's fabled Lycian Coast a real summertime treasure.

This 13-day adventure includes the first 2 nights in Istanbul, 8 days on our modern luxury yachts, sailing and exploring and swimming, plus an additional 2 nights in Istanbul, allowing plenty of time to visit the Great Bazaar, the Blue Mosque, Hagia Sophia, the Spice Bazaar, Topkapi Palace, and so much more.

David Kory and Tradewinds are offering this fabulous sailing adventure for the amazing low price of just \$3,485 per person, which includes private cabins on the modern, fully equipped yachts, round trip airfare from San Francisco to Istanbul and Istanbul to Gocek, 4 nights of hotels in Istanbul, and all transfers. The only thing you'll spend money on there is food, drink and souvenirs.

David Kory and Tradewinds have taken hundreds of adventurers on scores of charter trips all around the world, and it is always the best trip for the best price. In fact, more than 60% of the people on these trips have been on an adventure with us before, and know what a great deal it is. For all the details and more photos, go to:

www.TradewindsSailing.com and click on **Sailing Adventures** or contact David directly at davidkory@gmail.com



Tradewinds Sailing School and Club

2580 Spinnaker Way, Richmond, CA 94804

Phone: (510) 232 - 7999

Email: staff@tradewindsailing.com

"Your sailing dreams come true at Tradewinds!"

Basic Keelboat (101) - \$595*

Feb 2,3,4
Feb 7,8,14
Feb 15,21,22
Feb 18,19,20
Feb 21,22,28

Basic Coastal Cruising (103) - \$795*

Feb 13,14,15
Feb 14,15,21
Feb 23,24,25
Feb 28 & Mar 1,7
Mar 1,7,8

Bareboat Chartering (104) - \$995*

Mar 8,14,15
Mar 9,10,11
Mar 22,28,29
Mar 25,26,27
Mar 29 & Apr 4,5



Advanced Docking & Motoring (118) - \$195

Feb 21
Mar 14
Mar 27

Coastal Navigation (105) - \$295

Mar 14,15

Radar Course (120) - \$295

May 15,16,17

**New Mates Membership for only \$30 a month.
Enjoy discounts and events with Tradewinds!**

Winter Special!
Take \$100 off any of the above courses* or take advantage of our 3 Class Package (101,103 & 104) at \$1895.00

*Expires 2/28/09

www.TradewindsSailing.com

We Still Offer More!



Making boating easier – and more fun! is what a marina should be all about.

That's why Oyster Cove Marina rates number one with many Bay Area boaters. It's an exclusive yet reasonable facility of 219 berths, accommodating pleasurecraft in slips up to 60-ft long.

Oyster Cove is the private Peninsula marina closest to Blue Water boating.

Want to cruise to Sausalito, lunch at Tiburon, or sail to Angel Island? How about a day's fishing outside the Gate, or a weekend at the Delta? No other private Peninsula marina is better situated or offers nicer, fresher surroundings.

- Berths 30 feet to 60 feet
- Double Finger Concrete Slips
- Telephone Available
- Five Minutes from SFO
- Heated Dressing Rooms & Showers
- Laundry Room
- Nightly Security Patrol
- Complimentary Ice
- Cable TV/High Speed Internet
- Recently Dredged
- End Ties Available at \$5.75/Ft!



OYSTER COVE MARINA

385 OYSTER POINT BOULEVARD #8A
SOUTH SAN FRANCISCO

(650) 952-5540

LETTERS

others — will find somewhere else to play in the future.

On the subject of massive price increases, we're told that one of the major marinas in the British Virgins raised their berth



LATITUDE / NICK

The St. Barths government seems determined to drive tourism away by jacking up anchoring fees island-wide.

rates 50% without any increase in services or improvements in the facilities. The result was that just about everybody, even the high-rolling owners, moved their boats out. Although the marina subsequently rescinded the price increase, the miffed owners still haven't seen fit to return. Price gouging in these very difficult times doesn't seem like a smart move.

↑↓ WHERE DID THEY STORE THEIR RIG?

January's *Sightings* had a fascinating story of Simon Winer and Claire Arbour making a very fast trip down to Bahia de Los Angeles in the Sea of Cortez with their Moore 24 *Extra Action*. But where did they store their truck and boat trailer?

It's also possible to get to the Sea of Cortez via Yuma, Arizona, which is only 65 miles from the Sea.

Jim Mikkelsen
San Pedro

Jim — Simon and Clair stored their truck and trailer in a nearby hotel parking lot — for a reasonable fee.

While it's only 65 miles from Yuma to the Sea, what are the cruising attractions that far north in the Sea? It's our understanding that there are few. What's more, the farther south you get in the 750-mile-long Sea, the warmer the air and water tend to be.

↑↓ WE'RE PLANNING A SURF-CENTRIC TRIP DOWN BAJA

Several folks have pointed me in your direction for information regarding surfing destinations between San Francisco and Panama where there is good access from a cruising boat. I'd like the emphasis to be on Baja, but other data would be welcome as well.

I'd like to explore the coast from Cojo anchorage — near Government Point and The Ranch, to the west of Santa Barbara — down to Cabo on the first leg of our trip. Unfortunately, many of the cruising guides only mention surfing in passing. And the surfing publications and other surf reports focus on surf spots that can be reached by land.

My girlfriend Shawn and I would like to make our south-bound trip surf-centric, and as such hope to put together a list of remote, hard-to-get-to-by-land breaks that would also be suitable for an anchored sailboat. Any suggestions?

Chris Jaquette
Tao, Nor'West 33
Berkeley

Chris — We've been too busy with sailing to have accumulated a list of promising surf spots easily accessible by boat, but there are plenty of them along the coast of Baja and farther down. Various surfers/sailors in the Ha-Ha were telling us they were stopping in places we'd never heard of, and that they had great waves to themselves. And even once you get to the Cape,



Paradise Village™ MARINA

Treasure of the Mexican Gold Coast



Share with us our Successful combination:
Special Price | Service | Security | Location

Services:

- Electrical service, 110/30 amps
- 220/50 amps and 3 phase 100 amps
- Crystal Clear Potable Water
- Cable TV
- Garbage Collection
- Pump - out Station
- Fire Fighting Boat Protection
- 24 Hrs. Security
- Computerized gate access

Additional Services:

- Vallarta Yacht Club
- Special area for marina guests
- Restrooms
- Lockers
- Showers
- Pool and jacuzzi
- Free access to all the facilities of our 5 star hotel
- White sand beach
- Dive tank refilled
- Propane refill
- Launch ramp



CONTACT US: marina@paradisevillagegroup.com
Phone & fax from U.S. 011-52-322-22-66728
www.paradisevillage.com



SHAFT SHARK

**The best rope,
line and debris
cutter there is!**

Two piece unit

For both
power and sail



AB Marine, Inc.

747 Aquidneck Ave.
Middletown, RI 02842

401-847-7960

Fax: 401-849-0631

sales@ab-marine.com

www.ab-marine.com

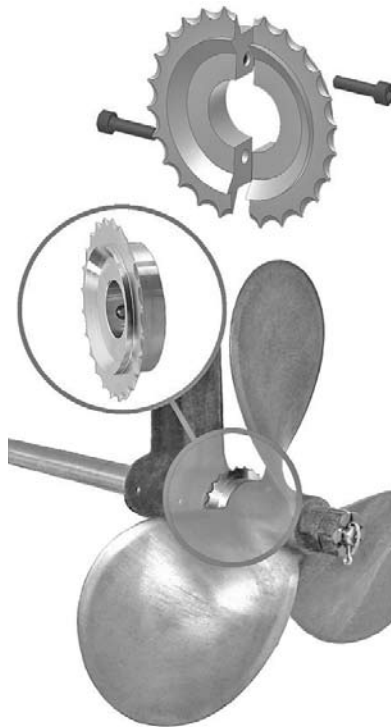

LETTERS

there are a bunch of fine surf spots that are only easily accessible by boat. The cool thing about being able to anchor at a surf spot, even if it's relatively easy to access by land, is that you're



Banderas Bay is just one of the many great spots to sail and surf in Mexico.

always right there to know when the waves are the least crowded or when nobody is out at all.

By the way, as we wrote this response in December, countless fine waves

were breaking and unriden on the north coast of Banderas Bay, and the water temperature was in the low 80s. The night before, we'd surfed until nearly an hour after sundown, and never felt the slightest chill.

If there is anyone out there who would be happy to share their cruising boat-friendly list of surf breaks with Chris and his lady, they can be reached at jaquettcd@hotmail.com.

↑↓ I THOUGHT IT WAS AN APRIL FOOL'S JOKE

Thank you for your editorial reply to the disheartening letter from Gary Barnett and Marianne Smith, who seem to be very judgmental about there being a correct way to cruise.

I'm a new sailor and, while reading that letter, began to doubt my experiences over the past year. But somewhere after the first few paragraphs of that missive, I concluded that it had to be an April Fool's joke, and checked the publication date of the magazine. Alas, it was not a joke — at least not an April Fool's one.

Sailing was one of the items on my Bucket List that I hadn't checked off, but then my wife made the mistake of reading a billboard advertising a boat show while we were driving down I-95 near Richmond, Virginia, last year. I found the highway exit and walked into a wonderland of new boats.

I live on Lake Gaston, North Carolina, am a powerboater of long standing, and therefore am not easily impressed. But the sight of a Beneteau 34 standing tall above the hundreds of other boats took my breath away. Even my "not quite a sailor" wife was impressed with the cabin, but I thought the whole boat was the most beautiful object that I'd seen in some time.

While at the same show, I came across a booth run by Capt. Dave Wilbar, manager of the Sailtime Virginia Beach port, where I was introduced to fractional ownership and the American Sailing Association. I am now ASA101 certified and bought my first boat, a Cal 21, which is perfect for a novice such as myself on our lake.

Since that first talk with Capt. Dave, I have met many dozens of sailors, and I find that I like all of them. Well, there is one exception, but I won't go into that here. All of them have been helpful and kind, and generous with their time and their willingness to share their experiences and suggestions. In light of this, I believe that Barnett and Smith's letter is an anomaly and in no way reflects the attitude and experiences of the rest of the sailing world.

I live about two hours from Norfolk, which is the closest saltwater to me, and *Latitude 38* is not available around here.

Gori® propeller

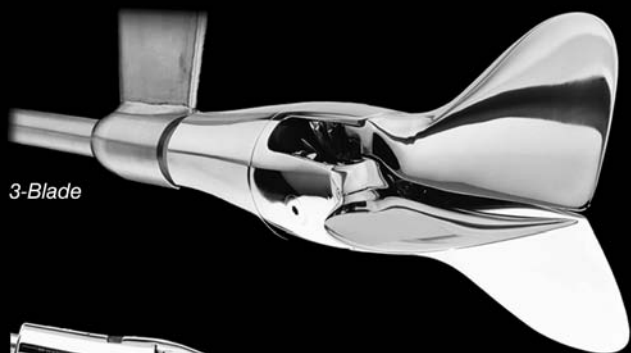

3-Blade



2-Blade



Racing

AB Marine, Inc.
747 Aquidneck Avenue
Middletown, RI 02842

Phone: 401 847 7960

Fax: 401 849 0631

sales@ab-marine.com

www.ab-marine.com

For more than 25 years, yacht owners have been able to trust **PACIFIC COAST CANVAS** for the best in design, service and quality.

• **Offshore Dodger™**

Welded aft handrail
Bolt-on side handrails
Lexan windshields

• **Baja Awning™**

Lightweight and waterproof
Durable and easy to launch
Multiple side screen configurations



Tim Shea has his new toys: a new Jeanneau 45DS and new Offshore Dodger.

• **Coastal Dodger™**

Affordable designs
Same high quality materials
Same superior workmanship

• **Cruiser's Awning™**

Easy setup off your dodger
Flies with no bulky frame
Comes with shade screens

Open Monday-Friday 8:00-4:00
Saturday by appointment
(510) 521-1829





**2021 Alaska Packer Place
Alameda, CA 94501
Grand Marina**



BLUESTORM

Prepare for the unexpected

Bluestorm Inflatable PFDs provide the ultimate in style, safety and value.

- Three sailing models with built-in harness
- Manual, fully automatic, or convertible inflation
- USCG approved

Bluestorm
P.O. Box 210
Plympton, MA USA
(877) 688-5657
www.bluestorm.us

HI PERFORMANCE LIGHTING FOR THE OPEN SEAS

Brighter Than Conventional Lighting
Performance In Excess of 50,000 Hours

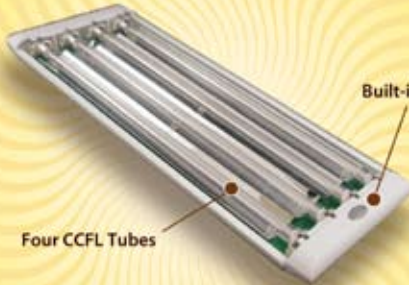

Built-in Dimmer
Four CCFL Tubes

UPGRADE YOUR BOATS INTERIOR LIGHTING SYSTEM!
Lunasea also offers GEN 5 full spectrum LED fixtures that output up to 100 Watts of equivalent light.

LUNASEA LIGHTING

1.800.272.0170 www.lunasea.com



WHALE POINT MARINE & HARDWARE CO.

A FAMILY OWNED & OPERATED BUSINESS FOR THREE GENERATIONS
ACE Hardware
 MARINE PARTS & ACCESSORIES, PLUS A COMPLETE HARDWARE STORE

Go to WhalePointMarine.com for additional discounts!

MOELLER OIL CHANGER

5 qt container, self-priming pump, 3 sizes of hose to fit your dipstick!

List \$109.99
NOW \$69⁹⁹



FILTER 500 FGSS by Racor

Filter Element
 West \$10.55
Whale Pt \$8⁹⁹

Filter Unit
 West \$199.00
Whale Pt \$169⁹⁹



FORESPAR Mini-Galley

NOW \$119⁹⁵

Mini-Galley comes with tibble cooking frame, perfect for any boat and uses standard propane cylinders.



DEHUMIDIFIER by Dri-Z-Air

Removes moisture from interiors of boats & prevents condensation.



Complete unit
Now \$9⁹⁵
 Single refills
Now \$1⁹⁹

DECK BRUSH with Handle

Extra long handle (5ft) with aluminum no-rust, threaded tip.
Now \$13⁹⁸



CANVAS BUCKET

Very handy bucket to have on your boat. Barely takes up any space... simply fold down to store.



List \$24.99
NOW \$19⁹⁹

FOULWEATHER GEAR by Dutch Harbor

NOW \$49⁹⁹ - 69⁹⁹

The affordable protection. Full suit includes jacket and bib-pants.

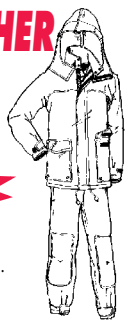

GILL Deckhand Gloves

FREE with purchase of Gill Foulweather Gear Suite



Gill—present quality in sailing gear. Sizes: S, L & X.
 List \$19.95 • **Whale Pt. \$16⁹⁵**

205 Cutting Blvd, Corner of 2nd, Richmond
510-233-1988 • FAX 233-1989
 Mon-Sat: 8:30am - 5pm • Sun: 10am - 4pm • whalepoint@acehardware.com
 Go to WhalePointMarine.com for additional discounts!

LETTERS

But I have a sailing friend who lives in Norfolk, and he brings me copies of *Latitude* when he visits his weekend home on Lake Gaston. I have enjoyed many hours of sailing and conversation on Lake Gaston with Charley aboard his Catalina 22.

I plan on continuing with my sailing education, and maybe I'll someday find a way to join in the Ha-Ha.

Bill O'Neill
 Cal 21
 Henrico, NC

Bill — We can't remember the last time we got as much positive reaction as we did to our editorial response to the Barnett and Smith letter. The very essence of cruising is doing it whatever way you want. Big boats, small boats, full time, part time . . . whatever, whenever and wherever. If you've always had a problem with authority because you've needed to do things your way, cruising is for you.

ALTERNATOR MAINTENANCE 101

One of the most common problems that seem to afflict boats that have just started cruising, or have just started to be sailed again for the season, is that the alternator doesn't charge the battery. The field connections on alternators seem to be especially prone to failure. There are a number of reasons for this:

1) They live in the engine compartment, which often contains saltwater, fumes, and/or hydrogen from batteries. All of which are corrosive.

2) While the alternator output connection is usually a stud with a nut and lock washer on it, the field connection is usually a Faston quick-disconnect terminal. The alternator vibrates with the engine, while the wiring harness is usually tied to the bulkhead. This often causes vibration directly at the connection — the worst possible place for it — causing an intermittent connection.

3) The field winding has inductance. (Don't worry, most engineers these days don't really understand what inductance is/does either.) This makes the impact of the vibration-related, intermittent connection much worse, as is explained below.

Inductance is present whenever wire is formed into a coil, especially if there is iron inside the coil, as in an alternator field coil. When current flows in any inductor, a magnetic field is created. This field is what makes the alternator work, so there's no way around it. But in addition, this field stores energy. If the connection is broken, the energy needs to go somewhere.

When current is changed in an inductor, this stored energy creates a voltage that opposes the change in current. The faster the current is changed, the higher this voltage. I could explain it all in differential calculus, but just trust me. This is also the reason you can blow up your alternator by switching your battery switch while it is charging. Extremely high voltage — hundreds, even thousands, of volts — can be produced, blowing out the diodes or even breaking down the insulation inside the alternator.

Back to the field winding with an intermittent connection. This voltage will appear across the connector as it disconnects, causing an arc. This can weld the connection shut, but more often just removes a chunk of metal from the connector, and deposits carbon at the interface, while also heating the connection locally. After a while, it's all over but the shouting. It's a vicious cycle of more intermittences, more arcs, a worse connection and so forth. You may have noticed the arc at the plug when you unplug your vacuum cleaner without turning it off first — it's the same thing.



ULLMAN SAILS

"Fastest Sails on the Planet"

Sales, Repairs, Professional Sail Evaluation and Consultations for all your Racing Sails, One Design Sails, Coastal and Offshore Cruising Sails

CONTACT AN ULLMAN LOFT OR REP FOR SERVICE AND SALES

LOFTS:

Newport Beach
 (714) 432-1860
 2710 S. Crodgy Way
 Santa Ana, CA 92704
 Dave Ullman
 Bruce Cooper
 Steve Beck
 Erik Shampain
 John Bennett
 One Design
 Charlie Ogletree

San Diego
 (619) 226-1133
 2805 Canon
 San Diego, CA 92106
 Jim Clinton
 Tom Niebergall
 Chuck Skewes
 Ty Hokanson



Long Beach
 (562) 598-9441
 6400 Marina Drive #9
 Long Beach, CA
 90803
 Bryan Dair
 Steve Beck
 (562) 243-9710

Marina del Rey/ King Harbor
 Mike George
 (310) 645-0196
 Steve Beck
 (562) 243-9710

Ventura
 (805) 644-9579
 3639 E. Harbor Blvd.
 #111
 Ventura, CA 93001
 Gary Swenson
 Deke Klatt

Santa Barbara
 Ken Kieding
 (805) 965-4538
 Gary Swenson
 (805) 644-9579

Santa Cruz
 Brent Ruhne
 Ruhne Racing
 (831) 295-8290 mobile

Puget Sound
 Jeff Carson
 Marine Servicenter
 (206) 383-8618
 Jon Thompson
 (253) 732-0911
 John Leitzinger
 (253) 988-7245

Visit our website: www.ullmansails.com

Live your dream!

Call us today about FREE West Coast delivery, a \$60,000 value!

FUSION Catamarans

bmax242@yahoo.ca • (604) 465-1662

KISSINGER CANVAS

Marine Canvas & Interiors
STEVEN KISSINGER
(925) 825-6734
Covering the Entire Bay Area



- Biminis
- Boat Covers
- Cushions
- Sail Covers
- Headliners
- Awnings

DODGERS

Side handrails and window covers included.

OPTIONS

Aft handrail, dodger cover, sailing bimini.

Free Estimates and Delivery

BLUE WATER YACHT INSURANCE

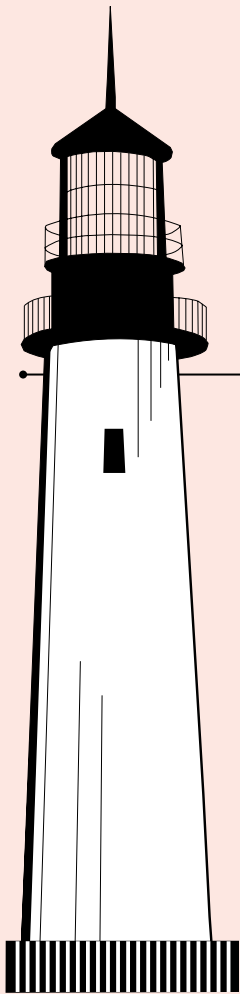

Blue Water Yacht Insurance covers more active cruising boats than any other marine agency in the Western Hemisphere, and is the leading innovator of insurance products for the offshore sailor.

Our Insurance Programs Provide:

- Crew of two anywhere
- Worldwide Navigation
- Hawaii
- Caribbean
- South Pacific
- Charter Boats
- Multihulls
- Liveaboards
- Racing Boats

Quality Rated Insurance Companies

Boats aged 1 to 40 years • "Agreed Value"
"All Risks" • "New for Old" replacement partial losses
Hulls valued \$50,000 to \$2,500,000

Worldwide Health Insurance

International and USA health insurance plans
at affordable prices.



Call Toll Free
(866) 463-0167
Fax: (866) 795-3707
sales@bluewaterinsurance.com

Quote requests
Visit our website

www.bluewaterinsurance.com

LETTERS

To avoid these problems, I have two suggestions for my customers:

1) Replace the female field quick-disconnect on the field wire every year or two — before it fails. Then carefully examine the male connector on the alternator. If necessary, clean it with 1,000-grit sandpaper, being careful not to sand through the thin tin plating on the tab.

2) Install a loop of high-flex wire — at least 49-strand, though preferably 133- or even 361-strand — between the connector and the existing wire, and physically attach it to the engine. This way the vibration will be in the wire between the engine and the bulkhead, not right at the alternator field connection.

Actually, the best thing would be to eliminate the connector completely and solder the connection. But care must be taken not to unsolder the field connection inside the alternator, or the alternator will need to be rebuilt.

Although the connection at the alternator is the most likely to fail, the connection at the other end of the wire, the regulator's field connection, and the regulator's ground connection — which everyone seems to ignore — also see the field inductance. Although they usually see less vibration, if these connections go intermittent, they will arc too, and things get nasty fast. I suggest careful examination of them as well, and replacing these connectors every few years can do no harm.

I know this is more of an answer than you expected, but I'm an engineer. I hope everyone understands the cause of these problems, and now they'll know more than most electricians ever will.

Michael Daley
Redwood Coast Marine Electrical
Point Richmond

⇕ **BOATS FOR JUST THE BAY AND DELTA**

From time to time, you've responded to readers' requests for advice on various kinds of cruising boats. My girlfriend and I are relatively new to sailing and are looking to buy a boat, but because of other commitments, don't have any plans to sail outside the Gate anytime soon. And given the high cost of housing, we're even thinking about living aboard. All right, I'm more up for living aboard than she is, but can you give any suggestions for 'big bang for the buck' boats for the Bay and Delta?

Tony Arrcardo
Sacramento

Tony — It's too bad you didn't mention your ages, because that would have had some influence on our advice, but we're going to assume that you're between 22 and 32. For younger and more adventurous sailors, it's possible to go with something as small as 22 feet. However, we'd strongly recommend a proven design for the windy waters of San Francisco Bay, something like a Santana 22. Such a boat would be wet crossing The Slot and in ebb tides, so you'd want good foul weather gear, too. She'd also be very tight for overnights at Angel Island or Clipper Cove, but for young folks, it's all about the adventure, isn't it? Boats this size are too small for living aboard.

The next category would be around the 27-ft range. Back in the heyday of Southern California boatbuilding, which was in the '60s and '70s, there were many fine 27-footers built by the likes of Catalina, Cal, Ericson, Ranger, Islander, Yankee and others. Some had inboards, some didn't. Boats in this size range are big enough to handle all but the very roughest days on the Bay, and are large enough for as many as four young folks or a family to take up to the Delta for a week or two. As

KKMI **Maritime**
Full Service Boatyard

One Stop – Many Experts - Combined to Deliver Quality and Value.

Put off the haulout long enough?

CALL KKMI TODAY
2009 Stimulus Rates &
Satisfaction
Guaranteed!!

530 West Cutting Boulevard
Point Richmond, CA 94804
Chandlery (510) 237-4141
Office (510) 235-5564
yard@kkmi.com
www.kkmi.com



ServiceShip™

Dealers for:



YANMAR
marine

JOHN DEERE

VOLVO PENTA



Dealers for:



HARKEN

NAVTEC
Rigging Solutions™

LEWMAR

ULTRA SMALL CABIN AND WATER HEATER

DEPENDABLE COMFORT

Be comfortable all year round with a quiet, reliable Webasto hot water heating system. Can be linked to pre-heat an engine and provide all the hot water you'll need in the galley or for showers.

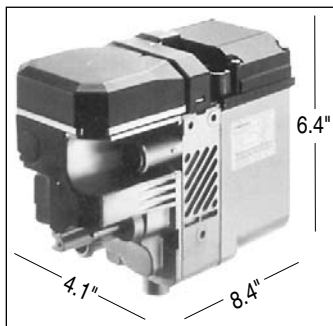

Webasto

CERAMIC IGNITION SYSTEM

- Heat output 17,200 btu/hr (5kw)
- Fuel Consumption .18 gal/hr
- Power Consumption 32 w
- Weight 6.4 lbs

CALL FOR MORE INFORMATION



SWEDISH MARINE

1150 BRICKYARD COVE RD., SUITE B6
PT. RICHMOND, CA 94801 (510) 234-9566

BOATSMITH, INC.
Boatbuilding - Marine Carpentry



Specializing in composite wood construction

Authorized builders for James Wharram Designs and Reuel Parker. We can build to any design you desire.

561-744-0855 561-632-2628

WWW.BOATSMITHFL.COM

Jupiter, Florida



Now's the time for a Tune-Up!



Take advantage of the off-season to have our experienced staff design the ultimate package to optimize the performance and look of your boat. Custom rigging is available through any West Marine store location.



- Installation Available
- Running Rigging
- Standing Rigging
- Dock and Anchor Lines
- Lifelines

Contact us at 888-447-RIGG, or visit our Onsite Rigging Locations in:

Alameda 730 Buena Vista Ave. (510) 521-4865	San Diego 1250 Rosecrans St. (619) 255-8844	Seattle 1000 Mercer St. (206) 292-8663
--	--	---

LETTERS

for living aboard, we consider this to be the minimal bachelor pad size.

The next step up would be in the 30- to 32-ft range. Once again, there were countless designs built in the '60s and '70s by Southern California and East Coast manufacturers. Generally speaking, by moving up to this size range you get more speed,



LATITUDE / LADONNA

A Catalina 30 is just one of the many boats that are good for living aboard and sailing comfortably.

size, comfort — and an inboard diesel. As far as we're concerned, this is about the minimum size in which two people could live aboard comfortably.

There are people who have sailed boats in this size range for decades and have been satisfied that they didn't need anything larger for the Bay and Delta. And no matter if you're talking about a Catalina 30 or a Bristol 32, more than a few of them have been cruised to Mexico and beyond, and even raced to Hawaii.

Over 32 feet, you just get more of everything, including comfort and liveaboard space.

While newer boats are more expensive than these classics from the '60s, '70s and '80s, if you've got the money, they are worth looking into. The difference in size, usable space, comfort and features between a boat from the '60s and the '70s and those of more recent vintage is dramatic.

One caution. Many first-time boat buyers are fooled into buying fixer-uppers. Unless you can absolutely steal one to the point that you should be wearing a mask and carrying a gun, avoid them, because bringing boats back to good condition always takes way more time and money than a novice can possibly imagine. Instead, look for a boat that's been loved and maintained well. Thanks to today's economy, it's both a great time to buy a boat and a great time to liveaboard.

Since you're new to sailing, you may not know that Latitude was started aboard a 41-ft Bounty II sloop — which because of her 27-ft waterline was a lot smaller than she sounds — that served as our home, office, photoboot and recreational craft. She wasn't that roomy or luxurious, but we wouldn't have traded the experience — or the low cost — for anything.

WE CLEANED UP OUR ACT AND LOST 125 LBS

Like many Americans, my wife Mary and I have been in a constant struggle to maintain a healthy weight and manage our cholesterol and blood pressure. Over the years we've tried all the diets, and while we did achieve short term results, nothing worked over the long term.

The last straw for me was when I saw the attached picture from Canada Day '05, when we were cruising in British Columbia. I didn't like what I saw. That started us on a sincere quest to 'clean up our act'. By last summer we'd made progress, but had only gotten halfway to our goals. Plus, my doctor wanted me to go on cholesterol medication and to up my blood pressure medication. So obviously we hadn't cleaned up enough.

Celebrating 25 years of excellent customer service



Discover

Brisbane Marina



GREAT LOCATION! Just minutes to Central Bay sailing.
GREAT RATES! \$5.90/foot!
GREAT FACILITIES! All concrete docks.
 Newly constructed bathrooms and laundry rooms.
KAYAK STORAGE! \$25 per month.



From Hwy. 101, take the Sierra Point Parkway exit and follow the signs to the marina.

400 Sierra Point Parkway
 Brisbane, CA 94005
 (650) 583-6975
www.ci.brisbane.ca.us
harbormaster@ci.brisbane.ca.us



Celebrating 40 Years of Excellence

Survive Your Dream

'Great Atlantic Gear Test'
 Always rated #1 or #2!

Courtesy Jimmy Cornell



YACHTING MONTHLY October 2006

100 best bits of gear - ever!
 HYDROVANE included twice!

Hydrovane is both:
 ☆ Self Steering
 ☆ BEST Emergency Rudder

SHOWERS EVERY DAY!

ECH₂O Tec Watermakers

BUILT TO LAST

www.hydrovane-watermakers.com

www.hydrovane.com 604-925-2660 info@hydrovane.com

DIMEN

Marine Financial Services

"A better way to get a boat loan."

Boat Loans



Loans Starting at \$25,000

Fixed Rates

New and Used

Liveaboard

Northern California

Bill Kinstler

866-486-2628

dimenmarine@pacbell.net

Sail a Small Boat Day

Richmond Yacht Club

Saturday, February 28

11 am to 4 pm



"The small-boat sailor is the real sailor."

— Jack London

See and enjoy **FREE** sails on small boats like:

29er	49er	Aussie 18 skiff
CFJ	Coronado 15	El Toro
Hoot	International 14	International Canoe
Laser	Lido 14	Optimist
Santana 22	Snipe	Sunfish
Thistle	Wabbit	Weta

...and more!

Fleet representatives will be available to talk to you about boats.

For information visit the RYC website:

www.richmondyc.org

LETTERS

Fortunately, we found two doctors in the Bay Area who have taken medically sound approaches to health and weight management: Dr. John McDougall and Dr. Dean Ornish. Both have websites with information on their programs: www.drmcDougall.com/free.html and www.webmd.com/diet/ornish-diet-what-it-is.



Before and after — Mary and Bill have lost a combined 125 lbs since changing to a nearly vegan diet.

www.drmcDougall.com/free.html and www.webmd.com/diet/ornish-diet-what-it-is. These lifestyle diet changes are medically sound and scientifically

based. They originated from studies of the diets of the healthiest world populations. Fundamentally, they are starch-based, low fat (less than 10% total calories from fat), no added sweetener, and vegan.

We've found that we can eat as much as we want of the whole foods on the diet, without any portion controls needed. The diet works because we're eating healthful vegetables, fruits, grains, legumes and other plant-based products. We also exercise moderately when we can.

As a result of making this lifestyle change, neither of us feels deprived, which is important. But the results speak for themselves. Our weight is down. In fact, I've lost 70 pounds and Mary has lost 55 pounds. My blood pressure has gone from 180/110 to 120/70, and my total cholesterol has dropped from 260 to 150. So I'm off all blood pressure, cholesterol and other medications. We feel more energetic and alert than ever.

Diabetes has become a huge problem in the United States, and my mother's family has a long history of diabetes. But thanks to the diet, my blood sugar has dropped from 110, which is pre-diabetic, to 74, which is great.

Unlike the other diets we tried that resulted in yo-yo results, this is a lifestyle change that we've found to be easy to stick with. But since it's a lifestyle thing and not a religion, we've been known to still occasionally have a 'feast day' — such as last night when we had pizza and beer at Philo's with other cruisers.

And vegan food can taste good, too! We know this because our vegan chile continued our winning streak at the Vallarta YC and Zihua SailFest — four Chili Cookoff wins in four tries!

While not everyone will get the same results that we have, it's worked for us, and it may well be worth a try for others.

Bill Finkelstein and Mary Mack
Raptor Dance, Valiant 50

Tiburon / But mostly the Mexican Riviera

In a typical month, we receive a tremendous volume of letters. So if yours hasn't appeared, don't give up hope.

We welcome all letters that are of interest to sailors. Please include your name, your boat's name, hailing port, and, if possible, a way to contact you for clarifications.

By far the best way to send letters is to email them to richard@latitude38.com. You can also mail them to 15 Locust, Mill Valley, CA, 94941, or fax them to (415) 383-5816.

**REPAIR
REPAIR
REPAIR**

**NOW AT
GRAND
MARINA**

**YOUR ROLLER
FURLER UV COVER
SPECIALIST**

ROOSTER SAILS

2021 Alaska Packer Place, Box 18, Alameda
(510) 523-1977

www.roostersails.com • rui@roostersails.com

Open M-Th 9-6 • Fri 9-5 • Sat by appt.

Owned and Operated by Rui Luis • Experienced Sail Repair and Fabrication

NOW OFFERING NEW CRUISING SAILS!

SAIL REPAIR SPECIALISTS • COMPETITIVE RATES • RECUTS • CONVERSIONS

Own a dock on San Francisco Bay! Perfect Location - Great Investment

Just dredged
deep water channels

EMERY COVE
YACHT HARBOR

BUY A SLIP – Save money & earn equity! Save 1/3 of your rental cost. Enjoy big tax savings as a slip owner. Emery Cove Yacht Harbor is the only marina on the Bay with FEE SIMPLE (not a grounds lease) dockminium ownership.

OR RENT A SLIP – 35-60' slips, rates from \$8.25 to \$9.25.

MARINA GUARD – cutting edge electrical monitoring system.



Certified

CALL FOR A MARKETING PACKAGE • 510-428-0505

3300 Powell Street, Emeryville, CA 94608 • www.emerycove.com • Email: info@emerycove.com

COVER CRAFT

**SAIL DRY
LOOK GOOD
SAVE MONEY:
20% FEBRUARY DISCOUNT**



Never restitch: All sewing in Tenara thread

- Classic dodgers and biminis
- Wavestopper hardtop dodgers
- Drop-top folding dodgers
- Enclosures • Custom canvas

1230 Brickyard Cove Road, #106
Pt. Richmond, CA 94801
In Brickyard Cove Marina

(510) 234-4400

Quality
Yacht
Canvas



WHERE DO YOU WANT TO GO?

Maretron can get you there using less fuel. We monitor fuel rate and report fuel economy so you can set engine RPM for the best fuel burning efficiency. And, we monitor tank levels to provide distance and time until empty so you have less to worry about. So get out your destination list and head off to sights unseen.

Maretron
Leading the way in NMEA 2000™ technology

To find out more about all of Maretron's vessel monitoring products, visit us at www.maretron.com
866.550.9100

CAPTAIN'S COURSE ONLINE

Accredited and Coast Guard approved
also approved for Military TA and Veterans



Captain's License

We now offer courses **OnLine!**

We believe the the interactions and structure of a classroom provide the best training experience. Even so, for some students attending a scheduled course just isn't possible. We'd like to help.

Our industry and school associates report that only about half of those signing up for online courses ever finish them. So, we created a better, more engaging and complete course. Read and listen to the lessons, take the pretests and you will be pass the course - all while enjoying a the best online learning experience. As always at Maritime Institute, you'll have our staff and instructor support before, during and after the course.

www.CaptainsLicenseOnline.com

MARITIME INSTITUTE

To enroll or for school info: www.MaritimeInstitute.com
or **CALL TOLL FREE 888-262-8020**

LOOSE LIPS

Unknown soldier.

It's a good feeling to know that *Latitude* brings a bit of enjoyment to people's lives. But we feel particularly honored and humble to learn that it also brings a bit of home to G.I.s who are far away from their homes.



Mom, apple pie... and 'Latitude'? Mr. Heldenbrand takes some R&R.

We wish we could tell you exactly who this soldier is. All we know is that he's in Iraq, and that he is the husband of Lois Heldenbrand, who wrote a charter report for us awhile ago. However, after numerous attempts to contact her, we have heard nothing back. Nor were we able to get more information from the person who sent the photo.

So, Mr. Heldenbrand, the sailing soldier, we're sorry we don't know exactly who you are. But we give you a hearty New Year's salute, and hope you and all our other troops will be home soon.

Amy a hero?

Tabloids are calling British singer Amy Winehouse a hero after she rescued a woman whose dinghy capsized near the beach on St. Lucia on January 6. The singer reportedly ran across the beach to help Louise Williams after the boat in which Williams was taking sailing lessons was capsized by a wave and hit rocks.

"Let's have a look at you!" Winehouse said after helping Williams ashore. She then took Williams to the nearby showers, helped mend her cuts, and kept asking, "Are you all right?"

"It shows there's another side to her," said Williams of Winehouse, whose longstanding 'bad girl' image has been fueled by drugs, alcohol and outrageous behavior over the years.

Oceans in trouble.

It doesn't take a lot of time on the internet or in the library to realize the world's oceans are in trouble. In fact, a real challenge would be to find something *positive*.

After reading an excellent overview called *Troubled Waters* that appeared in the January 3 *Economist* magazine, we're thinking the current state of the economy looks downright rosy by comparison. Pollution, overfishing, territorial land grabs, the 'curse of carbon,' temperature shifts, invasive species, rising sea levels, politics — you name it. When it comes to the oceans, everything's getting worse. There are pinpoints of light in the darkness, but they are few and far between. Here are a few highlights from *Troubled Waters* and other recent articles:

- A 2006 UN environmental study estimated that every square kilometer of ocean held nearly 18,000 pieces of floating plastic. Much of it was, and is, in the central Pacific, where scientists believe that as much as 100 million tons of plastic flotsam are suspended in two gyres of garbage over an area twice the size of the United States. About 90% of the plastic in the sea has been carried there by wind or water from land . . . (*The Economist*)

- Wise controls — if they are backed by good science and enforced — can and do help various fisheries worldwide. "Those who doubt the value of government intervention have only to look at the waters off Somalia, a country which has been devoid of any government worth the name since 1991" says *The Economist*. "The ensuing free-for-all has devastated the coastal stocks, ruining the livelihood of local fishermen and encouraging them, it seems, to take up piracy instead." (*The Economist*)

Launching in June 2009

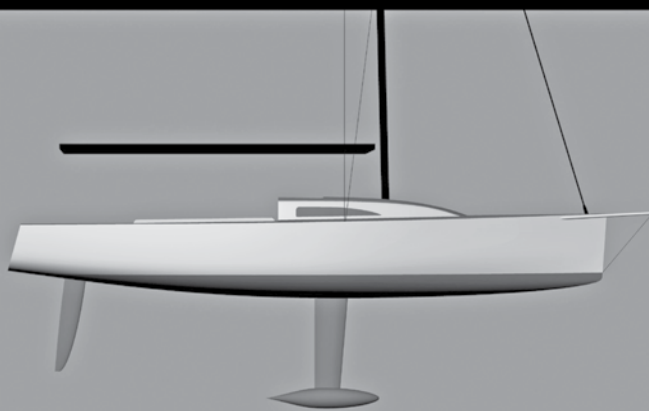

LS-30

LOA	Draft	Displacement	Rigging	Hull	Power
27 ft 10 in	6 ft	4,073 lbs	Carbon	Cold-molded	Inboard diesel



The Landing School

www.landingschool.edu

Z BLOK WON'T BURN YOUR EYES



Z Blok sunscreen's new non-greasy formula will not burn or irritate your eyes. So you can concentrate on winning the race or just enjoying a great day on the water. Z Blok is also fragrance free.

Z Blok is the official sunscreen of the PUMA Ocean Racing Team. Skipper Kenny Read said:

"The UV protection is excellent. The entire team is true believers. We have put the sunscreen to a tough test that few others can. More importantly, we have experienced no eye stinging or irritation and we use it every day."

Visit zbloksun.com

OFFICIAL SUNBLOCK OF THE PUMA OCEAN RACING TEAM



ON A ROLL.

Schaefer is known worldwide for premium quality jib furling systems that will stand the test of demanding ocean passages. Our drum-bearing unit is machined from a solid block of 6061-T6 aluminum, creating unparalleled strength. Torlon bearings assure smooth operation so you can keep rolling along in the most demanding conditions.

SCHAEFER
LEGENDARY STRENGTH

508.995.9511
SCHAEFERMARINE.COM

Ultra Anchor

**Quickest Setting!
Highest Holding!**

Quickline USA — Marine Products
from the World, for the USA

- Highly polished 316L stainless steel
- Self-aligning and self-burying
- Always lands in attack position
- Sets quickly and holds tight in the most challenging conditions



As strong as it is beautiful, Ultra Anchor is produced for the discerning yachtsman who wants *only the best!*

Ultra Anchor's self-righting design is simply better. The shank is hollow, and the lead-filled base keeps the center-of-gravity right at the tip—so when the Ultra Anchor hits the sea floor, it is automatically in penetrating position.

Why settle for a dull galvanized, ineffective anchor? No need, when you can set your vessel apart with Ultra Anchor!



15561 Computer Lane #A,
Huntington Beach, CA 92649
Phone: 714-843-6964, Fax: 714-843-6906
www.quickline.us or info@quickline.us

Code: 03668

ePaint
Eco-friendly Bottom Paints

Introducing new **SUNWAVE®** Photoactive Release Coating

- Copper-free
- Economically priced
- Hard, scrubbable finish
- Ideal for all rigid hull types
- Self-priming on bare aluminum
- Patented photoactive technology



Perfect for California and made in the USA
San Diego 619-929-7604, San Francisco 415-717-1297

800-258-5998 www.epaint.com

ePaint Company * 25 Research Rd * East Falmouth, MA 02536

SEA FROST®



COOL IT YOURSELF!

Refrigeration has never been easier. Sea Frost's compact and powerful, 12-volt BD refrigeration conversion kit comes pre-charged and ready for owner installation.

Sea Frost...Quality at an affordable price!

Local Dealers:

**Anderson Refrigeration Co. • Alameda, CA
(510) 521-3111**

**Poole Refrigeration Service • Alameda, CA
(510) 523-3495**

www.seafrost.com

LOOSE LIPS

• The total biomass of live fish in the world's oceans amounts to between 1 billion and 2 billion tons. British and Canadian scientists produced the estimates as part of a study of the role played by fish in the marine carbon cycle. This cycle is changing as carbon dioxide, added to the atmosphere by human activities, dissolves in the sea. Researchers have concluded that fish play an important role in counteracting the growing concentrations of CO₂ — fish excrete calcium carbonate, which helps neutralize the increasing acidity of the oceans. (*Science Today*)

• Commercial fishing and a desire for Asian shark fin soup sees up to 100 million sharks — even protected and endangered ones — slaughtered around the world each year. (*Australia Shark Research Institute*)

• Overfishing, particularly of large apex fish, unbalances an ecosystem. Relentless shark fishing off the Atlantic coast, for example, has resulted in a huge increase in the numbers of their prey, notably rays, skates and smaller sharks. One species of ray that eats shellfish is now so numerous that it has devastated the scallop, oyster and clam populations. (*The Economist*)

• The 'seaweed bloom' that interfered with the sailing portion of last summer's Olympic Games off Qingdao, China, was due to raw sewage and agricultural run-off. Together these sources polluted 83 percent of China's coastal waters in 2008, according to state media. China's coastal waters last year witnessed 68 red tides, in which blooms of algae feed off nutrients found in excess pollution, but at the same time deplete the water of oxygen, which results in the killing off of a wide variety, and large amounts, of sea life. (*Xinhua News Agency*)

YOUR BOAT DESERVES IT!

Fully Insured & Marina Approved

**Polishing • Detailing • Maintenance
Bilge Cleaning • Washdown
Carpet and Cushion Cleaning**

Serving the Bay Area Since 1986

CALL NOW FOR SPECIAL WINTER RATES

510 428-2522 or 415 457-6300
www.seashine.net

Wright Way designs

Custom Yacht Interiors

PROFESSIONAL DESIGN

SERVICES INCLUDE

CUSTOM

carpeting

cushions

designer fabrics

draperies

linens

upholstery



Deborah Wright
510.908.3939

2900 Main Street #67, Alameda, CA 94501

wrightwaydesigns@hotmail.com

Check out our new web site:

www.wrightwaydesigns.com



**ESSEX
CREDIT**

NEW - USED - REFINANCE

Boat Loans Made Easy®



Let our 27 years of experience go to work for you!

Richard Tressler
866-377-3948 ext. 47008

www.essexcredit.com

EQUAL CREDIT OPPORTUNITY LENDER

Loan Amounts from \$15,000 Instant Loan Approvals*
Zero Down Program* 90 Days to First Payment*

*(Subject to Loan Program Guidelines and Credit Approval)

Reference Code =MAR931

in Southern California...



*A First Class Full Service Facility Serving the Entire Pacific Coast
150 Ton & 30 Ton Travelifts*

VENTURA HARBOR BOATYARD

**Open 6 Days a Week!
Competitive Rates ~ Professional Staff**

*For quality and attention to detail you can count
on our commitment to your satisfaction.*

(805) 654-1433

1415 Spinnaker Drive, Ventura, CA 93001
www.vhby.com

Our response to the economic meltdown

Scanmar has cut costs in 2009 by not attending some of our usual domestic and international boat shows. We're passing on the savings to our customers. Call us today regarding the best discounts ever on all our windvanes during the month of February!



The Green Solution

www.selfsteer.com



FACTORY DIRECT

SCANMAR
INTERNATIONAL

432 South 1st St. • Pt. Richmond, CA 94804
Tel: 510 215-2010 • Fax: 510 215-5005
Toll Free: 888 946-3826
email: scanmar@selfsteer.com

SIGHTINGS

***l'hydroptère* hits 61 knots**

Moments before it capsized on December 20, the 60-ft French foiler *l'Hydroptère* hit 61 knots. That's a tick over 70 mph, the legal speed limit on some California highways. It's doubtful the brief burst will be ratified by the WSSRC since, to qualify as official, a speed must be maintained over 500 meters. But for Alain Thébault and his team of believers, that evening was one of vindication and celebration. There was time enough that day to tow the boat home and start feeling their cuts and bruises.

Thébault and famed French sailor Eric Tabarly conceived the idea for *l'Hydroptère* ('the hydrofoil') way back in 1975. The complex, 5-ton boat — which in winds above 12 knots rises onto port and starboard foils forward and a combination rudder/'elevator' in back — was launched in 1994. Sailing hydrofoils have been around for a long time. But nobody had ever built anything like this one before. So

continued on outside column of next sightings page

new date & rate

The official start to the sailing season is closing quickly so in an effort to help you find crew — or a position on a boat — as early as possible, the *Latitude 38* Spring Crew List Party will be held on March 11, nearly a month earlier than usual. Every year we bring skippers and crew together on 'neutral ground' to make connections, made easy by the color-coded name tags everyone wears.

The party will once again be held at Golden Gate YC from 6-9 p.m., and will feature the usual munchies, no-host bar and demos. But this year we're offering



for crew list party

a discount to sailors under 25 — just \$5! For the rest of us, it's still only \$7.

But before you get all gussied up for the party, be sure to surf on over to our website at www.latitude38.com and click on 'Crew Lists'. Not only will you find forms specific to your situation but you can view the current lists of boats looking for crew, or crew looking for boats — in real time. You don't even have to fill out a form to contact someone who's already on the list. But the best part of the crew list is that it's totally free!

— *ladonna*

l'hydroptère — cont'd

the learning curve consisted largely of sailing the boat, seeing what worked or broke, and then fixing any problems before the next outing. And lots of stuff broke. Thébault has suffered, nursed and repaired his 'flying boat' through many breakdowns over the years.

Prior to the latest breakdown, *l'Hydroptère* had a good couple of months. In early November, Thébault sailed to two new records off the team's homeport and proving ground, Port Saint Louis du Rhône, which is on the Mediterranean coast of France, near Marseilles. The first was 43.09 knots over a measured mile, which beat their own previous record. The second was 46.52 knots over 500 meters, which finally dethroned a 1993 record set by the Australian podsailor *Yellow Pages Endeavor* as the fastest sailboat on the planet. In early December, Thébault and his team made several personal appearances at the Paris Boat Show, drawing enthusiastic crowds. Then it was back to

continued on outside column of next sightings page



Warp Factor 10 — 'l'Hydroptère hit unbelievable numbers before pitchpoling. Normal sailors would have been upset, but this crew was celebrating.

SIGHTINGS

l'hydroptère — cont'd

the waters off Napoleon Beach for the big push: break not only the top speed of any watercraft under sail — currently 49.84 knots set by a kitesailor last September — but also break through sailing's sound barrier, the almost mythical 50-knot mark.

Four days before Christmas, Thébault and his nine-man crew did just that. With winds in the 35- to 38-knot range and a smallish swell, *l'Hydroptère* was flying along in the high 40s when she encountered a 45-knot gust. Boat speed climbed to 50 knots, then 55, 60, and finally, 61. Shortly thereafter, the boat pitched, tossing the crew into the water and coming to rest upside down. The cause of the capsizing was the very gust that permitted the extraordinary speed burst.

"The gust was very violent," said Thébault. "*l'Hydroptère* was in full acceleration at over 61 knots when she stopped and capsized." As the crew were pulled out of the water by chase boats — a routine many of them are doubtless used to — there were the usual cuts and

continued on outside column of next sightings page

ease the sheets

Back in the 1800s, when virtually everything produced on North Bay acreage was hauled to market aboard ships and scow schooners, nobody was concerned

about such high-falutin notions as carbon footprints or ecological sustainability; it was simply the only way to get the job done.

Today, however, there's a renewed interest in the idea of sailing products to market



COURTESY CLARK BEEK

Clark Beek.

A recent aerial photo of Westpoint Harbor shows, not only the progress made, but also the channel leading through the marshland to the marina. Inset, what started out as a work dock soon turned into a party barge.



PHOTOS COURTESY WESTPOINT HARBOR

& pass the pinot

— at least in the mind of circumnavigator Clark Beek, whose around-the-world adventures were featured in last month's issue. Picking up on a niche within the North Bay wine industry that produces organic and otherwise earth-friendly wines, Beek is testing the waters, so to speak, of a new concept. He proposes to transport cases of *vino* aboard his 40-ft ketch *Condesa*, from wineries near the Napa and Petaluma Rivers to restaurants or stores on or near a waterfront, such as Pier 39, Jack London Square and Sausalito.

While the concept may sound a bit
continued in middle column of next sightings page

l'hydroptère — cont'd

bruises. But there were also big smiles and high-fives and hugs. Official or not, they had finally done it.

— jr

Update — At this writing, l'Hydroptère was sitting in chocks at her shore base. After taking a week off for the holidays, the team returned after New Year's to begin the long process of assessing damage and disassembling the boat. The goal is to have her back in the water for another all-out speed attempt by April. For more on this amazing craft, go to www.hydroptere.com/_en/

westpoint marina update

January 2009 marks 21 years since work began on what has — *finally* — become Westpoint Harbor in Redwood City. The idea was a full-service marina with a boatyard, fuel docks, rowing center, and big-boat slips in South San Francisco Bay. As detailed in several *Sightings* articles over the past few years, the vision of developer Mark

Sanders was to convert an old salt bittern pond into the Bay's newest recreational boat harbor. Little did he know in 1987 that it would take so long. He went through 10 years of paperwork and permits before the first shovelfull of dirt was ever turned.

Although the 'official opening' of West Point will not take place until the clubhouse is completed this summer, the 'first phase' of the harbor has been open for business since late last year. About 50 of the 155 slips from 44-60 feet are currently occupied, and the 1,000 feet of guest docks have been put to good use many times. There are also end ties to 120 feet, as well as a few ultra-wide catamaran slips. More similar-size slips are coming when phase two is completed in March. When all the docks are in, the harbor will have 406 slips averaging 50 feet in

length. According to Sanders, it was a bit of a gamble putting in only large slips. "But there are already lots of smaller slips available in the Bay," he observes. And the change seems to be paying off, with 2-3 boats a week signing up.

Once the docks are all in, work will begin on the boat ramp, dry storage, restaurants and other supporting construction on the land surrounding the marina.

Among the most popular features of this state-of-the-art marina are the pumpout 'spigots' right on the dock — located at the junction of every third slip, one spigot can service the four or five closest boats. Other amenities include round ends on the fingers, 'inboard' pilings, high-speed DSL lines to every slip, and a nascent WiFi system.

But the biggest surprise to Sanders is the popularity of the Professor Farnsworth Party Barge. During the development of the Marina, Mark met with several dozen dock manufacturers before

selecting Bellingham Marine in Washington. As part of that process, he purchased some sample docks with wood decks (the main docks are concrete), which he planned to use in the boatyard. However, one berther, a Santa Clara University law professor named John Farn-

continued on outside column of next sightings page

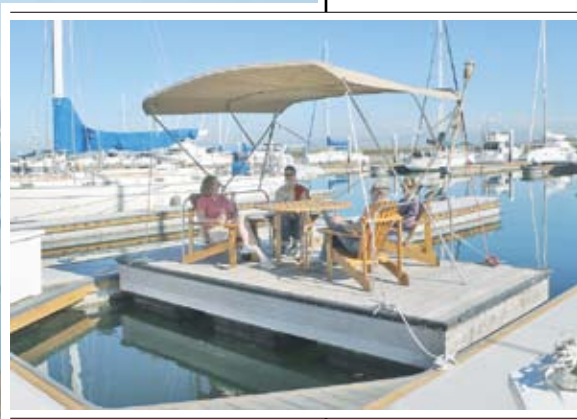

The clubhouse's completion will mark the official opening of this long-awaited South Bay marina.

SIGHTINGS

westpoint — cont'd

sworth absconded with the small section of dock. He added a bimini, Adirondack chairs, some rails and even tiki torches. Now the dock serves as a community "party barge." Whoever is entertaining guests that weekend tows it over, ties it off behind their boat and lights up the barbecue! So far, Sanders has been unable to reclaim the party barge.

In late January, workers completed the last of the channel dredging, removing a bar at the entrance to Westpoint Channel from the main Redwood City shipping channel. "Now it's at least 12 feet deep from here all the way to, well, Hawaii!" says Mark.

For more information on Westpoint Marina, including berth rates and how to sign up for a slip, go to www.westpointmarina.com.

— mark sanders & jr

get out the boat

You know that (fill in the blank) streaked with mildew in the slip or trailer spot next to yours? The (fill in the blank) with the oxidized

gelcoat, rotten sail covers and a protective layer of dirt? Do you find yourself wishing you had bigger fleets to race against? Then why not help get that unused boat out on the water?

That's what a group of sailors from the Moore 24 fleet, led by Pacific Northwest Fleet Captain Ben Braden and his *More Uff Da* crew — wife Jennifer, Melanie Edwards and Joe Wilderman — have in mind. To that end, they've hatched a campaign to help fleets and yacht clubs make it happen. They're calling it "Get Out the Boat."

Conceived on one of the crew's lengthy road trips back and forth from racing their Moore in Northern California events, the campaign aims

to encourage people to rediscover their boats and get them back on the water.

"We found Moores with trees growing on them and wanted to try to get them out racing," Braden said. "But we realized it wasn't just a Moore problem."

Actually if anything, the Moore 24 is one of the strongest one-design fleets on the West Coast. But like any successful fleet, it knows that constant fleet building is essential to maintaining good turnout. For Braden and the other sailors nationwide who have been hoisting the Get Out the Boat flag and its adjunct, "Race Locally, Motivate Globally," last fall's election plus the 'get out the vote' catchphrase were a perfect dovetail for what they're trying to accomplish. Both rallying cries are about enfranchising people and increasing participation, and both are free.

"The idea is to make it fun and get people out," Braden said. "That will hopefully help get the industry moving again to benefit people in both the industry and the yacht clubs."

To give the campaign something visual for people to identify with, the group devised a logo and printed 400 stickers — which, in just a few short months, were snapped up by sailors across the country. To save money in this entirely grass-roots effort, they had the oval-shaped logos printed on rectangular bumper stickers — then cut all 400 out with scissors. To go along with the sticker, they wrote a letter, customiz-

continued on outside column of next sightings page

pinot

far-fetched, you have to admire Beek's entrepreneurial spirit, and hey, wackier ideas have certainly proved successful here in the Bay Area — the cradle of innovation. An added twist would be to carry passengers, who could sample his wares while enjoying the scenery.

At this writing, Beek doesn't have any firm transport contracts yet, but he's had a lot of fun testing potential 'delivery routes' and tasting 'product'. And there is definitely a trend within the industry

COURTESY BEN BRADEN



Braden and crew are the evil geniuses who came up with a simple plan to motivate folks to sail their boats.



— cont'd

toward sustainable and organic production techniques, not to mention 'biodynamically' produced wines which factor in lunar phases and planetary cycles — remember, this is California.

We say more power to him. After 10 years of living the cruising life out in the fresh air, we can certainly understand why he's not eager to jump into a desk job in a windowless cubicle. We only wish our offices were closer to the waterfront.

— andy

gotb — cont'd

able by anyone to suit their own region, yacht club or fleet, to help build awareness. Here's the San Francisco Bay version, courtesy of Spinnaker Sailing's Drew Harper:

Let's see you get out to as many races as you can this coming year! Motivate everyone you know to get out sailing, Race Locally, Motivate Globally! Get Out The Boat 2009!

The 2009 GOTB campaign's focus is to get as many boats out sailing and racing as we possibly can. We are in a unique situation here in the San Francisco Bay Area. We have a group of people who love to sail in any condition, fleets that feel more like family than racing foes, and organizations full of excitement and dedicated members. Push that energy outward to other boat owners you don't see out racing, boats

continued on outside column of next sightings page

Get Out The Boat doesn't just apply to racers. Cruisers and daysailors should take up the cause and get sailing too!



SIGHTINGS

gotb — cont'd

that have sat too long on their trailers or at their moorage, to anyone in your yacht clubs that isn't out having fun on the water! Many of the fleets need our support, both handicap and one-design. Let's use our energy to get as many people out sailing as possible! Get out on the water in 2009, do your local races, make some big regattas, harass other people into sailing their boats! Don't forget the campaign slogan: "If we can't take your boat out sailing . . . we'll harass you into sailing it yourself."

To help spread the logo around, the campaign — with the help of Bay Area sailor Edward Killeen — has set up a Get Out The Boat gear site with Cafe Press at www.cafepress.com/GOTB, where you can find everything from the sticker to logo-sporting T-shirts, thongs and boxer shorts. Other than Cafe Press, no one is making money on it. We've already ordered a T-shirt plus a sticker for our transom! Thanks to Bay Area sailor David Nabors — who sails his Olson 34 *Temerity* out of Alameda — you can find a copy of the letter, a link to the gear, and soon a blog where you'll be able to post pictures and stories about how you've helped someone 'get out the boat' at www.getouttheboat.org.

— rob

a sad start to

A sad sight greeted New Year revelers at the end of 2008: a sailboat washed up on Ocean Beach. Early Coast Guard reports that the Clipper Marine 30, *Sherrie Mae*, had broken loose from her mooring turned out to be incorrect. It seems that, while the unnamed owner was out of town for the holidays, his son took the boat out for a spin and ran into trouble in the fog.

The details of the event are murky but the Coast Guard confirms they received a report of a person in the water around 5 p.m. on December 29. By the time a lifeboat reached the scene, however, the San Francisco Fire Department reported that all three passengers had been pulled from the water, and that *Sherrie Mae* was in waist deep water about 25 yards off the beach. The Coasties contacted the owner,

Before she was removed from Ocean Beach late last month, 'Sherrie Mae' had been totally stripped and suffered even more graffiti.



JOHN SHUPING

the new year

who assured them he would remove the boat when he came back to town a few days later.

But it didn't take even that long for *Sherrie Mae* to be stripped of anything of value. Ocean Beach resident John Shuping said that one guy, who was lurking near the boat clutching a socket set, told him "I'm here to steal the winches!"

In fact, more of *Sherrie Mae* went missing every day as the vultures picked at her carcass. But the bulk of her remained, settled firmly into the sand, until January 21, when she was removed — either by the owner or, more likely, the Golden Gate Recreational Area. If it was the latter, the former can look forward to a hefty bill to start off the new year.

— *ladonna*



governor targets dbw for 'termination'

If you think belt-tightening in the national economy is going to be painful, wait until you see what the state of California is going to have to do to balance their deficit.

The California State Budget has been a bad joke on a runaway train for long time. It was the bane of many a governor and the undoing of one — you may recall that Arnold Schwarzenegger rolled into office after Gray Davis was ousted for not balancing the state budget in 2003. Now Arnie is in the hot seat, facing the biggest and baddest 'terminator' of his career. To his credit, he is holding out for a workable solution rather than giving the usual nod and wink for yet another year of fiscal fiasco.

In an outline released by the Governor's Office in mid-January, Schwarzenegger outlined an 18-step roadmap for a more efficient state government. Some of it makes sense, but we probably don't have to tell you there's something in there for everyone to hate. When battling 'the machine', there's always going to be collateral damage.

The issue that will have the most impact on boaters is the Governor's proposal to eliminate the Department of Boating and Waterways. DBW would instead become a branch of the Department of Parks and Recreation. According to the outline, this move would save the state \$600,000 per fiscal year and, in the words of the proposal, "allow for better coordination and management of project and grants relating to boating access and safety programs."

Oh really?

A bit of background: Every governor since about Pat Brown (Jerry's father) has tried to rob from Peter to pay Paul — in this case, use money from the efficiently-run DBW to pay off losses from the less-well-managed Parks and Rec. To be fair, the latter is a lot bigger (operating on about five times the budget of DBW) and has a lot more variables to deal with, such as the rash of wildfires over the last few years. But the bottom line is that Parks and Rec loses a lot more than \$600,000 a year.

And according to RBOC (Recreational Boaters of California), the absorption of DBW into Parks and Rec would not save the state \$600,000. The fact is, DBW is so efficient that receives no General Fund dollars. It is funded entirely by boater fuel tax dollars, registration fees and infrastructure loans.

The bottom line for boaters is that DBW is a valuable entity. It issues grants for harbor and marina improvements, promotes safety, battles to keep state waterways free of invasive species, and on and on and on.

If DBW is absorbed into Parks and Rec, it's our feeling that many if not most of the good things it does will be lost or so diluted as to be ineffectual. We hope you will join us in telling the Governor (www.gov.ca.gov/interact#email) and your local state Senator (www.sen.ca.gov) or Assembly person (www.assembly.ca.gov) that DBW should remain autonomous.

— *jr*

drama in the vendée

If you started sailing in dinghies, you probably had a sailing instructor who implored you to "stay with the boat" whenever you capsized. That's exactly what Vendée Globe racer Jean Le Cam did — just long enough to be rescued from his slowly sinking IMOCA 60 by competitor Vincent Riou aboard *PRB*.

"I always had it in my head, 'do not leave the boat,'" said Le Cam, who'd been running in fourth place at the time. "But I didn't know how long I could live inside."

Le Cam's *VM Matériaux* went topsy-turvy January 6, some 200 miles west of Cape Horn after the keel bulb dropped from its fin following a collision with an unidentified object. For the next 10 hours, Le Cam was the only person on Earth who knew without a doubt that

continued on outside column of next sightings page

SIGHTINGS

vendée — cont'd

he was still alive and well. While making a distress call to his shore team, reporting “serious problems,” his satphone had gone dead. So when the news that Riou had made contact with Le Cam reached the wires, the Vendée Globe community, sailing enthusiasts and fans the world over breathed a collective sigh of relief. For Le Cam, ‘relief’ may be too weak a word.

“I heard Vincent’s voice in the morning, and thought, ‘Am I dreaming or not?’” Le Cam said. “Then I heard it again so I was sure he was



The world breathed a collective sigh of relief when Vincent Riou, right, managed to pluck Jean Le Cam from the icy waters.

there. That’s important — if you get out and there’s no one there, you’re in really bad shape because you might not be able to get back in. There’s only one shot at this.”

For the two skippers, it wasn’t just a matter of a simple step-aboard transfer. First, Le Cam had to

transit the interior length of his boat, from bow to stern, to reach the escape hatch.

Sound simple? Maybe with an upright boat — and without gear, spares and food plastered to the ceiling. Consider also that the stern of *VM Matériaux* was completely awash when a fatigued and chilled Le Cam had a decision to make, his life hanging in the balance.

“So I opened the hatch and things kept pouring out of the boat,” Le Cam continued. “Vincent saw things come out of the hatch, so I put my feet out first and got out in one movement with a wave. I held on, lifted my head up, and saw Vincent — which was a great moment.”

Adding to the complexity of the rescue was the fact that Riou was forced to carry it out without the use of his engine, which had previously died. It took him three practice runs before he was able to reach Le Cam with a heaving line as the latter, clad in a survival suit and having scrambled atop the hull, clung to one of his rudders. On the fourth, successful, attempt, Riou sailed so close that one of the deck spreaders that support his wingmast’s standing rigging made contact with the tip of Le Cam’s canted keel fin. The damage to the spreader would later force the duo to crash jibe to save the rig — for the moment.

“I came close the first time,” Riou said. “I came close the second time and I missed him, and on the fourth try I managed to throw him the rope,” Riou said. “The closer I got, the more risks I took. One big wave is all it would have taken for Jean to be sent off — you can’t resist the pressure of the water. The fourth time I got really close — the hulls didn’t touch but the keel hit my outrigger. At the time I didn’t really care. First I get Jean, then I’ll take care of my outrigger — my priority was set on getting Jean, no matter what.”

Although the two were able to save Riou’s compromised rig for the short term, a day later it came tumbling down. And so it came to pass that Riou and Le Cam, two frontrunners who had finished the 2004-05 edition of the race in first and second place respectively, found themselves being towed to safety — together on one boat without a mast or engine. Both were victims of the attrition that’s become emblematic of this edition of the Vendée Globe, in which 18 of the 30

continued on outside column of next sightings page

missing buoy mystery

For a typical sailor, the fact that an offshore navigational buoy mysteriously disappeared on December 30 probably wouldn’t be earthshaking news. But imagine how you’d feel if you were a bar pilot charged with bringing an enormous freighter safely into port, and the buoy in question was the crucial Sea Buoy marking the spot where seven shipping channels meet. It normally lies 12 miles offshore, pinpointing the proper approach to the Golden Gate.

Of course, pilots have a variety of navigational aids to guide them in, so the greater concern was that the 32-ft high, 26-ton monster might be adrift, posing a serious threat to mariners. Imagine the damage it could do to your boat if you smacked into it doing hull speed.

Fortunately, the mystery was soon solved. The Sea Buoy had simply sprung a



‘VM Matériaux’ hit a USO — Unidentified Submerged Object — which broke off the boat’s keel bulb, causing her to turn turtle. The world waited with bated breath to hear if skipper Jean Le Cam survived.

vendée — cont'd

starters have retired.

At the head of the pack of the remaining 12 boats, Michel Desjoyeaux is powering his *Foncia* north at this writing with a 300-mile lead and less than 3,000 miles to go. The man known as 'Le Professeur' reached the Equator some 21 hours ahead of Riou's 2005 reference time, with a favorable weather outlook to eclipse Riou's race record of 87d, 10h, 47m. As remarkable as Desjoyeaux's performance is by that measure, it's even more remarkable when considered in light of the two days he lost after having to return to Les Sables d'Olonne to repair his flooded engine. And, it's even more remarkable for the fact that the Vendée Globe is 1,160 miles longer this year — with the addition of the ice gates in the Southern Ocean — than it was in 2004-05.

Riou and Le Cam are already safely home and the former has been granted redress and will share third place, his position at the time of the rescue, with whoever is the third skipper back to Les Sables d'Olonne. We've been following this race pretty closely, and in a future issue of *Latitude 38*, we will run a wrap-up of it, including a look at the carnage that's beset the fleet in a future issue of *Latitude 38*. In the meantime, make sure you check out www.vendeeglobe.org/en to follow the fleet as it makes its way up the homestretch.

— rob

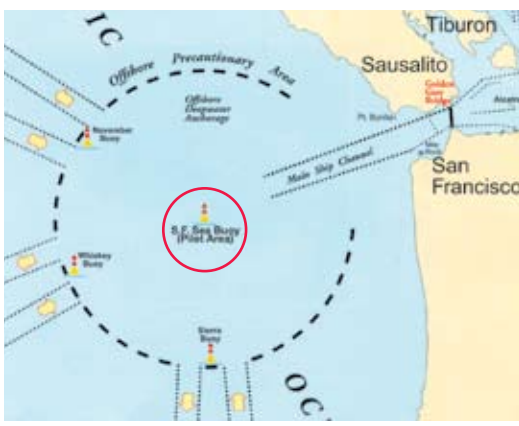

Of all the buoys to go missing, this was the most critical to the safety of the shipping lanes.

leak and sunk to the bottom, where it was recovered, still attached to its mooring, by the 225-ft Coast Guard Cutter *Aspen*. A replacement buoy is now in position while the original is being repaired. The Coast Guard is investigating the possibility that an outgoing ship may have struck the Sea Buoy while exiting the Bay.

— andy



SPREAD MARINE CHILLENNE / VENDEE GLOBE; INSET VINCENT RIOU

TIME IS RUNNING OUT FOR CALIFORNIANS TO REPRESENT THEIR STATE ON A GLOBAL STAGE – ARE YOU UP FOR THE CHALLENGE OF A LIFETIME?

THE START OF THE CLIPPER 09-10 ROUND THE WORLD YACHT RACE IS LESS THEN NINE MONTHS AWAY AND WITH BERTHS 75 PERCENT FULL, TIME IS RUNNING OUT FOR CALIFORNIANS WISHING TO TAKE PART. THE CLIPPER RACE IS IN THE ONLY ROUND THE WORLD YACHT RACE OPEN TO EVERYONE REGARDLESS OF PREVIOUS SAILING ABILITY OR EXPERIENCE.

In April next year the ten identical 68-foot stripped down ocean racing yachts contesting Clipper 09-10 will be speeding towards California and the hero's welcome that will await them there. They will include *California*, who will be racing alongside other internationally sponsored teams including *Uniquely Singapore*, *Qingdao* and *Hull & Humber*, and you could be onboard helping to sail her to victory and the prestigious title of Clipper Race Champions.



STEP OUTSIDE YOUR COMFORT ZONE

For those of you who have been glued to the latest editions of the Volvo Ocean Race and Vendee globe, the Clipper Race offers you an opportunity to emulate your ocean racing heroes. Or for those of you who are looking to step outside your comfort zone and take on a new challenge with like minded adventurers then the Clipper Race offers all this and more.

This is one of the world's toughest challenges and Californians from all walks of life can be part of it.

THE CREW

Under the watchful eye of a professional skipper, each of the yachts is crewed by up to 17 non-professional sailors, approximately 40 percent of whom are complete novices before embarking on their Clipper Training. They come from a whole range of different backgrounds from truck drivers to doctors, stockbrokers to students, each united by the desire to put their normal lives on hold and take on the challenge of a lifetime.

With a state population of nearly 38 million only 14 Californians have dared to take up the challenge of Clipper Race and to date only one has achieved the pinnacle of ocean racing, a circumnavigation. Ian Deas, a 42-year-old Investment Director

from Walnut Creek, was a round the worlder on *Durban 2010* and *Beyond* in the Clipper 07-08 Race. Ian says, "This has been one of the best experiences of my life – I'd recommend it to anyone. Completing

a circumnavigation was one of my goals when I applied for the race. Now that I've done it and I am able to sit back and reflect on my achievement, I am very proud of myself."



THINK YOU'VE GOT WHAT IT TAKES TO TAKE ON THE WORLD?

For an application form: visit www.clipperroundtheworld.com, email oceanracer@clipperroundtheworld.com or call +44 2392 526000

YOU COULD JOIN OTHER CALIFORNIANS WHO HAVE SUCCESSFULLY APPLIED FOR THE CLIPPER 09-10 RACE...

PEOPLE LIKE CHARLES WILLSON

The 49-year-old Advertising Agency Executive first heard about the race when he looked up from his desk one day and saw one of the fleet entering Santa Cruz Harbor during the Clipper 07-08 Race. From that moment on he was hooked - glued to the website for the rest of the race, reading the entire history of blog posts from each boat and becoming the first Californian to sign up for Clipper 09-10.



Charles says, "What Sir Robin Knox-Johnston (founder of the Clipper Race) has created is an incredible adventure that without Clipper would likely be an unreachable dream. I like a challenge and have no problem stepping out of my comfort zone. I am going to a part of the world I have not visited and will have an opportunity to greatly advance my sailing and boat management skills under an extraordinary broad range of conditions."

Charles will be getting onboard for Leg 4 of Clipper 09-10 which will take him to Singapore and Qingdao. "I feel my chosen Leg offers the most variety and will likely be the most arduous of the race," explains Charles. "I think the crew will be subjected to heat and cold, limited sleep and, at times, extreme sea states."

PEOPLE LIKE DONNA WOMBLE

The 45-year-old Californian Software Engineer applied for a berth on Clipper 09-10 because she was looking for a new sailing challenge and had been hankering for years to take part in a long distance race.



"I'm most looking forward to racing down the Californian and Baja coast," says Donna, who has been offered a place on Leg 6 from California to the Caribbean. "I think the hardest part will be getting through the anticipated light winds in Mexico and Central America - where it will also be rather hot."

Donna believes the Clipper Race offers her an experience of a lifetime. "It's a great way to see the world and meet a lot of interesting people in the process," she says.

PEOPLE LIKE MAX SPRING

The 44-year-old Software Engineer from San Jose first heard about race and considered applying when he saw some footage on TV of Clipper 05-06. Then a Clipper 09-10 Race presentation at Club Nautique in December last year saw Max queuing up for an interview.



Max says, "I think being at the helm when running the spinnaker in 20-25 knots of wind is probably what I'm most excited about. That and sailing as part of a crew who know what to do. Having said that, being together with a group of people in very close quarters could also be one of the hardest things about the race."

Max would love other Californians to join him on the Clipper 09-10 Race. "It's going to be the experience of your lifetime," he says. "If you have the time and the money: Just do it!"

STOP PRESS – CLIPPER RACE NEWS:

OFFICIAL COUNTDOWN TO CLIPPER RACE BEGINS

The countdown clock to the start of the Clipper 09-10 Round the World Yacht Race was ceremonially set in motion at the opening day of the London International Boat Show in January 2010.



Terry Hodgkinson, Chairman of Yorkshire Forward, the regional development agency behind the sponsorship of the *Hull & Humber* entry pressed the button to set the clock counting down the seconds to the start. When the starting gun fires on 13 September 2009 it will be the first time a round the world yacht race has ever started from the north east of England and the people of the Hull and Humber area are promising to give the fleet a spectacular send off.

Terry says, "I am looking forward to personally welcoming the race, its participants and visitors to the Humber for the race start and finish. We have superb venues and plan to put on a spectacular events programme when Clipper 09-10 sails into our region."

INCREASE IN US APPLICATIONS AS EXCHANGE RATE BENEFITS AMERICAN CREW

Following a successful crew recruitment tour in California and two US stopovers last year, crew numbers for Clipper 09-10 have already outstripped those of Clipper 07-08. Crew Recruitment Manager David Cusworth believes that one of the main reasons for this is the current state of the British pound.

David says, "With the weak state of our pound against the US dollar, berths on the race are now 25-30 percent cheaper for American crew than this time last year. Crew from the US who apply now are able to take advantage of the current exchange rates and this is one of the reasons behind the recent surge in applications I have received from America."

SIGHTINGS

the quiet ones

Mom always said to watch out for the quiet ones, so when we met David Tyler and Fran Flutter while hauled out at KKMI last fall, we paid attention. Their understated style, quick British wit, and, of course, their very distinctive bilge keeler, led us to believe that they had some tales to tell.

As it turned out, David, 63, and Fran, 60, left the 34-ft *Tystie* in Lowry's Marina in San Rafael while they traveled to Yosemite. (David, a devoted hiker, climbed most of the way up the Half Dome.) We finally caught up with pair after spotting them anchored in Richardson Bay at the end of January, on the eve of their departure from the Bay.

We're so glad we did.

David spent his professional life designing sailing hardware and working with the likes of famed British sailor Blondie Hasler. He retired at 50 and, after the death of his wife, decided to go cruising. But he needed an ocean-worthy boat, so he teamed up with British yacht

continued on outside column of next sightings page

puddle jumpers

Among the hundreds of cruisers arriving in Mexico, Central America and the Caribbean this season, many are undoubtedly considering making the 3,000-mile passage to the South Pacific this spring — a crossing we like to call the Pacific Puddle Jump.

As in years past, *Latitude 38* will devote lots of editorial coverage to that annual migration, and will hold special events in both Mexico and Tahiti for 'Class of '09' Puddle Jumpers.

Our Zihua Puddle Jump Kickoff Party is slated for February 9 (the day after the Zihua Sailfest, location TBA). And our Banderas Bay event will be February



SPREAD COURTESY OF EMERALD, INSET LATITUDE / ANDY

poised to pounce

12, 2-5 p.m. at the Vallarta YC, located at Paradise Village Marina in Nuevo Vallarta. Both events will be supported by the Tahiti Tourism Board, which will provide insightful literature and a highly informative digital slide show. Each crew will be interviewed and photographed for inclusion in *Latitude*. Plus, we'll have guest speakers, free PPJ burgees, party games, free drinks, snacks and more.

In celebration of the arrival of this year's fleet, *Latitude* will assist Tahiti Tourism in hosting the Tahiti-Moorea Sailing Rendezvous, June 19-21. This free event will be focused on cross-cultural

continued in middle column of next sightings page

Making landfall at Nuku Hiva makes up for the hardships of the 3,000-mile crossing. Inset, local dancers strut their stuff at the Tahiti-Moorea Sailing Rendezvous.

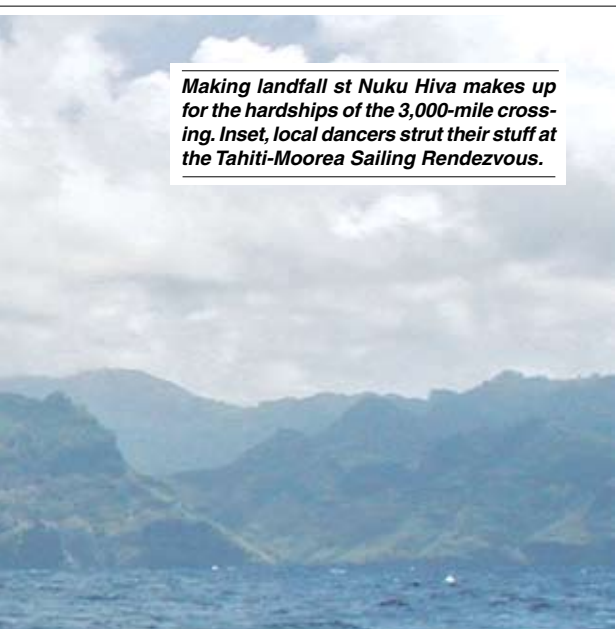

quiet ones — cont'd

designer — and neighbor — David Thomas to work up a design.

Tyler had previously built a 24-footer with his own hands — a feat that took four years — so he knew he could have built *Tystie* on his own, but he wasn't willing to take the time. With the help of a yard on the River Hamble, the cold-molded, single-masted — and unstayed — junk was finished in just 15 months, and launched in 2000.

For the next few years, David sailed *Tystie* around Great Britain, up to Norway, edging into the Arctic Circle, and back again. As an avid climber, he made a point of climbing every Munro (mountains over 3,000 feet) in Scotland — all 284 of them! "Some do them all in three months," he said of 'Munro baggers'. "I took six years."

Then, at the dawn of 2005, friend and sailing author Annie Hill introduced him to solo circumnavigator Fran Flutter. "She thought we might like to sail together," Fran recalled.

Fran was born with a bit of the sea in her blood. Indeed, she was moved aboard her parents' sailboat when she was just a week old. She completed an Atlantic circuit aboard their boat. Then, as an adult, she did another with her ex-husband aboard the gaff ketch on which they lived for 20 years.

"Since I was a little girl, I wanted to sail around the world," Fran said. So in 1995, after her divorce, she set off in her 35-ft sloop *Prodigal*. During the four years it took to complete her singlehanded circuit of the globe, Fran walked away with the Ocean Cruising Club's Rose Award (1996) and Barton Cup (1999) for meritorious voyages.

As it turned out, David and Fran did like sailing together. So much, in fact, that they took a cruise to Scotland in February "to make sure all the skills were there" — we didn't ask if the skills in question were individual or collective. Everything must have gone well, though, because, as David put it, "Fran cast her lot with me."

After returning to their homeport of Ravenglass from their next cruise to Iceland and the Azores, David decided to change *Tystie's* sailplan from a single-masted junk — with one massive 600 sq. ft. sail — to a ketch. "The single sail was a lot of fun but also a lot of work," he noted. "Things can get very unbalanced sometimes, and you can't reef deeply enough for ocean sailing."

With only minor interior alterations, they cut a hole in the deck and popped in the mizzen mast, which, like the main mast, needs no shrouds or stays. After changing out from a traditional junk sail to what David calls "soft wing sails," *Tystie* is much easier to handle but still scoots along like the dickens, especially downwind.

In June, 2006, David and Fran took off for good. They spent time exploring France, Spain and Portugal, wending their way up several rivers along the way — "I like poking up rivers," said David — and ending up in the Canaries.

"It's a jumping off point for the Caribbean," David explained. "Yachties gather there like birds on a telephone wire." But instead of following the pack, David and Fran once again took the path less traveled, sailing to Fernando del Noronha, an eco-tourism island off Brazil. From there they looped their way over to Cape Town.

That leg turned out to be the most difficult of their journey so far. About 1,000 miles west of their destination, they suffered their first knockdown. "We'd had a strong northerly for three days and then it died," David recalled. "Then it came up a strong southerly and the waves were tremendous. We fell off one and the mast went just below horizontal. That's a very awkward bit of sea."

Fran, who'd been on watch, was thrown across the cabin. "A piece of the cooker (stove) hit me in the head," she smiled. Asked if the injury required stitches, she replied "No, it was just very bloody."

About two hours later, on David's watch, *Tystie* suffered another knockdown that, again, sent Fran flying across the cabin. "I was fine," she said, "but the mess was just unbelievable. You think you've stowed everything, but you haven't."

continued on outside column of next sightings page

quiet ones — cont'd

They enjoyed their time in South Africa, where they claim the wine country is better than California because the wine is “just as good and dirt cheap.” From there they stopped at St. Helena — “If I were Napoleon,” said David, “I would have thought myself very lucky to be there” — and then on to Trinidad for a quick haulout before taking off for Panama. “When I dove on the bottom, the goose barnacles thumbed their noses at me and said ‘Nyah nyah,’” David laughed.

Once through the Canal, the couple made the obligatory trip to the Galapagos, which they claimed was worth the stop while bemoaning the extreme restrictions on visiting other islands. After a couple weeks, they continued on to the Marquesas — a 3,800-mile jaunt.

“We’ve done three trips through the Doldrums,” noted David, “and have arrived with nearly full tanks each time.” Much of that was thanks to their rain catchment system — *Tystie* has no watermaker, or many other ‘systems’ for that matter — but also due to Fran’s strict water rationing. “I’m allowed a little to brush my teeth,” David laughed.

They spent just a couple weeks in the Marquesas, which they allow was interesting but “very French.” Wanting to get away from the high prices, and in a bit of a hurry to reach British Columbia before the North Pacific turned snotty, they scurried up to Hawaii.

With one eye on the calendar, they toured the islands before leaving for Victoria, a trip that took them just three weeks. “I’m telling you, this boat goes!” David said. “We don’t hang about.”

Having sailed some 20,000 miles in just over a year, David and Fran settled for the winter of 2007-08 in Sidney, BC. “We thought we were due for a rest,” said Fran. But it wasn’t long before they got moving again. Last February, they began making their way up the Inside Passage.

By June, they’d made it as far north as Skagway, where David climbed the Chilkoot Trail. “That was a real highlight for me,” he said. But time was now running out quickly on their one-year U.S. cruising permit, so instead of sailing *Tystie* into famed Glacier Bay, they hired a seaplane to fly over it. Then they headed back south.

After stopping at the Queen Charlotte Islands, then heading to Desolation Sound for an Ocean Cruising Club Rally, David and Fran were ready to head down the coast. “We left Victoria on October 7 and caught the last of the summer northerlies” David recalled. “We had 30 knots of wind for three days that shot us right down.” They arrived in Bodega Bay on October 12.

As for their future plans, the couple says they’re going to hop down the coast and up to the Sea of Cortez. From there, they’ll join the Pacific Puddle Jump Class of ‘09 and head back to the Marquesas on their way to New Zealand. After that, they’ll jump to Australia — where one of David’s daughters lives — and then Tasmania. “That’s as far as we’ve gotten in the planning,” they claim.

But that’s not exactly true. David went on to say, rather wistfully, “Having seen Alaska . . . that’s my kind of place. It’s where I’m meant to be.” Now we know what Mom meant — this is one couple we’re going to keep our eye on.

— ladonna

learning the ropes & life lessons

There’s no doubt about it, an introduction to sailing can certainly change your perspective. Take, for example, the experiences of San Francisco sailor Anna Capp, who recently returned from three years

continued on outside column of next sightings page

ppj

appreciation and will include a cocktail party, a sailing rally to Moorea, Polynesian music and dance performances, and cruiser participation in traditional Tahitian sports — the highlight of which will be the six-person outrigger canoe races. It’s great fun for both young and old, so if you’re heading west this spring we strongly urge you to time your arrival at Papeete to coincide with the fourth annual Sailing Rendezvous.

We’re also happy to report that for



David Tyler and Fran Flutter have little interest in the spotlight. They’ve quietly made their way halfway around the world in the last year and a half aboard their David-designed 34-ft bilge keeler, ‘Tystie’.



— cont'd

the first time ever, we'll be working in cooperation with the Tahiti YC to get all officially registered Puddle Jump boats a bond exemption! This is a big deal, as each crew member normally has to tie up \$1,400 U.S. for the duration of their stay in French Polynesia. So three cheers for the Tahiti YC!

If you're heading across this year and would like to 'officially' register with us, email andy@latitude38.com.

— andy

life lessons — cont'd

in Africa with the Peace Corps. As she explains below, she gives part of the credit for her accomplishments to a local high school sailing program that challenges and inspires young women:

"My name is Anna Capp and I was a Tall Ship Semester for Girls (TSSG) cadet on the schooner *Californian* in 1999, the program's maiden voyage. Though I hate to be repetitive and say that TSSG 'changed my life', truth be told, it did. How could it not? TSSG was an amazing semester spent with amazing girls and a wonderful crew. I learned how to work as part of a team, overcome challenges, and push myself beyond my own expectations. I also had the pleasure of learning new, different, and exciting subjects. I saw my trigonometry

continued on outside column of next sightings page



PHOTOS LATITUDE / LADONNA

SIGHTINGS

life lessons — cont'd

class come to life in navigation mathematics and studied whales while actually seeing whales!

"TSSG was not an easy experience, which made it all the more valuable. Frustrations, loneliness, and many a seasick watch taught me how to take the good with the bad, handle difficult situations, and grin and bear it when there is work to be done. It was an amazing adventure that inspired me to continue taking the road less traveled.

"After college, I decided my adventures were not yet over. I wanted to continue to see the world, but having begun my adventures from the deck of a tall ship, somehow backpacking through Europe seemed too normal. Instead I committed myself to two years — and then a third — with the U.S. Peace Corps in Burkina Faso, West Africa. My memories of the eight weeks as part of TSSG were joined by three years of African landscapes, drinking tea on hot afternoons, trying to learn a local language, and all sorts of wonders that cannot be described.

"Like TSSG, my Peace Corps experience had its ups and downs (though not nearly as literally as being at sea). I was often filled with

continued on outside column of next sightings page

gone the way

You can still play those old LPs if you want, and by all means restore that old Herreshoff schooner. But as of February 1, that ancient 121.5 EPIRB of yours is not only be useless, it's illegal.

EPIRBs — Emergency Position Indicating Radio Beacons — are nifty gadgets. When turned on they emit a radio signal that informs anyone listening that you're in trouble, and where to look for you. EPIRBs have saved hundreds, if not thousands, of lives over the years. But the early ones, which transmitted on the 121.5 MHz band, were glitchy. They produced a lot of false alarms and had a host of other limitations that included poor signal strength, search areas that could be as large as 12 to 15 miles in



COURTESY ANNA CAPP

Anna began her adventures aboard the 'Californian' in 1999 as part of TSSG.



BOB GREISOR

of the dinosaur

radius, and unreliability. (This resulted in the Coast Guard's spending valuable time trying to make sure the signal and position were real before launching its boats or helicopters. And they still went on lots of wild goose chases.

About 20 years ago, some brilliant fellow invented a new breed of EPIRB that transmitted digitally on the 406 MHz band. Not only are digital signals, and the way satellites process them, highly accurate, but each individual EPIRB could have its own 'fingerprint'. When preregistered, that meant it could instantly inform searchers of the name of the boat, home port, contact numbers and so on. When one of those goes off, the Coasties make

continued in middle column of next sightings page



life lessons — cont'd

loneliness, frustration and a strong desire to catch the next plane home. But I knew I could handle it, that bad days are always followed by good, and that I was stronger than I could imagine. At the end of the worst of days I would look up into an African night sky, filled with brilliant stars, and remember seeing the same stars on the bow of the *Californian*, and feel the frustrations of the day simply melt away . . .

"The Peace Corps kindled a desire to do my part to change the world, but it was TSSG that fanned the fire of adventure leading me on to who knows where."

Anna is now back in school pursuing a nursing degree, with hopes of eventually working in far-flung destinations, possibly with Médecins Sans Frontières (Doctors Without Borders). The TSSG program is part of the Tall Ship Education Academy, a special project of San Francisco State University. The ongoing program combines hands-on, land-based training with a six-week tall ship voyage. Scholarships are available. For more info check out: www.tallshipacademy.org.



COURTESY ANNA CAPP

Anna more recently during her Peace Corps stint.

— andy

gosport bound

Having grown up Chinese-American in the Central Valley, Quan-an Au doesn't have the classic background one would associate with a sailor who's about to embark on a racing circumnavigation. But the 30-year-old director of technology for Halogen Guides, a luxury guide publisher in the City, will take the plunge, so to speak, when he starts the 2009-10 Clipper 'Round the World Race.

Although many of the people who ultimately sail the race will only do a leg or two, Au — who came to the Bay Area for undergraduate studies at UC Berkeley and now lives in Oakland — is one of the few who's planning on sailing the entire thing. Having seen footage of the 2005-06 edition, Au attended a pitch from crew recruitment manager David Cusworth at last year's Strictly Sail Pacific show — not even thinking at the time that it was something he would end up doing.

"I'd been thinking of stepping back from work for a little while," he said. Graduate school was one option; but it didn't take long before Au chose to put the money he'd saved toward the race. "My wife said, 'If you want do this, now's a good time.' She's been really supportive."

Au's introduction to sailing is, on its face pretty typical. He got into the sport with the encouragement of sailing parents. But his story differs because unlike those who grew up in sailing families, his parents — who are also supportive of his plans — didn't start sailing until three years ago.

"Everyone in my circle of friends and family is really excited," Au said, laughing. "I think maybe I haven't done a good enough job of communicating to them what it is exactly. Someone said, 'It sounds like you'll have plenty of time to read and relax.' It's hard for them to understand — sailing in general is foreign to them. Growing up, sailing was never something I would've thought about doing with my free time. Three years ago, my parents became the first Asian members of the Oakland YC, which isn't unusual, even for a club that's been around since 1913. Being Chinese-American — and growing up in Fresno — sailing wasn't something my friends' families did."

So what does Au hope to get out of the Clipper Race experience?

"I don't have concrete thoughts about that," he said. "I probably won't know until afterward whether it was worth it or not. For some people, school might be a better option, but ultimately we don't know how much time we have here. This is something I would like to have

continued on outside column of next sightings page

SIGHTINGS

gosport — cont'd

done in my life. It's out of the ordinary. It's a stretch to have and take an opportunity like this."

The Clipper Race bills itself as an event that doesn't require prior sailing experience to take part, and the participants bring a wide range

of experience levels to the table. Au represents the fresher end of the spectrum, having only started sailing recently. The bulk of his sailing has been on the Bay, racing aboard Emile Carles' Tartan 30 *Lelo Too*, and he'll bring all he's learned from Carles and sailing on the Bay when he travels to the Clipper Ventures base in Gosport, UK, in July to complete his required pre-race training. But before he gets there, he'll be doing some physical training — and a lot of eating. A lanky 5' 10", he'll be trying to add a little insulation to his frame.

"I joke with people that I'd like muscle, but I'll be just happy with fat," he said, laughing. "I've never been able to put on any weight. It's never really been an issue because I don't need it for

my normal existence."

Although crew on the Clipper Race boats rotate around all the positions onboard, Au said he's really keen to spend as much time as possible on the bow. One thing's for sure, coming in at a svelte 135 lbs, he'll be everyone's first choice to grind up the rig!

Although Au is paying for the race himself, he'll be trying to raise money for UNICEF along the way — anyone may contribute in his name at www.firstgiving.com/quannon. He is one of an increasing number of Northern California sailors slated to sail in the race, and we hope to introduce you to the rest in the coming months. In the meantime, check out the race's website at www.clipperroundtheworld.com.

— rob

a foggy eve's crossing

A two-day pilgrimage to San Francisco aboard our Moody 42 *Estrella* has become something of a New Year's Eve tradition for my husband Dennis and me. But, this year's wasn't going to be routine. Although we could see a bit of fog in the Slot from our Sausalito berth, no one suspected how quickly it was about to wrap us in another world. Dennis's sister Cyndi, an accomplished wind instrument player from Chicago, gave an exploratory toot on our conch shell horn to announce our exit, and off we went.

The fog thickened as we passed The Spinnaker restaurant. While what we imagined was Angel Island melted completely from view, we reconfirmed our waypoint setting for the Pier 39 entrance, posted sentries, and made sure the captain had his eye fixed on the radar. Within minutes, all attempts at orientation using our God-given five senses became useless, except perhaps for the vague sense that the brightest point was southwest.

"Is that brownish spot Alcatraz?" I asked. "No, it's over there." "Oh my goodness, is that a tanker headed right for us?" someone yelled. "No, it's a tour boat headed way aft." Just about the time I started to expect ghost ships or icebergs to pop out of the icy fog, Cyndi transitioned from the solemn fog horn tones she'd been sounding on the conch to a rousing version of *Jingle Bells*. That broke the tension, if not the fog, and it also broke the spell that our other crewman, Dero, and I had fallen into.

We heard the distinctive sound of a ferry boat bearing down on us fast from somewhere. She was west of us and we were able to make out a big silhouette passing very close to starboard. When the ferry cut her engines, our post on the bow began looking for the shore in earnest. We were within 80 feet of the darned thing when she yelled

continued on outside column of next sightings page

dinosaur

a few quick calls to the numbers on the registration. If the person on the other end says her husband really did leave for Hawaii a few days before, they go. If she says he's driving up 101 with the EPIRB bouncing around in the back of a pickup truck, they don't.

The 'con' of 406s is that they are expensive. Prices have come down in the last few years, but you'll still shell out from \$300 for small personal EPIRBs to \$600 or more for the newest water-activated models that feature built-in GPS. So people have continued using the 121.5

"Babalooooo" — Leave it to a musician to play tunes — on a conch shell — throughout a foggy passage.



Quannon Au.

— cont'd

models. But as of February 1, they can't anymore. On that day, Cospas-Sarsat, the international satellite-based search and rescue (SAR) system, ceased satellite processing of 121.5/243 MHz analog EPIRBs and began processing only the 406 MHz digital radio beacon signals. Use of the obsolete 121.5 MHz beacons is now illegal, as well as pointless, since nobody is listening anymore.

For more information on EPIRBs and the Cospas-Sarsat program, visit www.sarsat.noaa.gov.

— jr

foggy — cont'd

"Breakwater!" The man at the helm still couldn't see it for another few minutes but, by golly, the GPS was right on.

We sighed in relief as we turned into the entrance. Not one to miss a performance opportunity, Cyndi did an encore of conch-style *Jingle Bells* for the perpetual crowd assembled on the Pier. Sea lions added their bellowing chorus, and we broke into smiles, waving at the pier like homecoming kings and queens.

As we settled into our slip, other mariners from various points on the bay drew into the harbor and shared their own stories of a foggy New Year's Eve crossing. The fog had added some excitement to a short voyage and given everyone an excuse for a shot of cheer immediately upon arrival. With our tummies warming nicely to the welcome, we all agreed it was going to be an excellent New Year.

— sheri scott huette



SHERI SCOTT HUETTE

WHO YA GONNA CALL?

While cruising the South Pacific aboard their Catana 471 cat *Océalys*, former Bay Area sailors Maurice and Sophie Conti usually shut off their VHF at night when anchored. But since there was virtually no radio chatter in their vicinity on the night of October 12, they forgot to do so. That fact may well have meant the difference between life and



SOPHIE CONTI

The right man for the job: Trained as a rescue diver, Maurice thoroughly outfitted himself before attempting to cross the reef.

death for two Australians and a New Zealander who became shipwrecked on a Fijian reef.

As Maurice wrote shortly after the incident, "At 11:45 p.m. October 13, we were woken by something that every mariner fears: 'Mayday, mayday, mayday!'" It was the voice of a female crew member aboard the 32-ft Australian ketch *Timella*, which had run up on Takau Lakaleka Reef, roughly 50 miles southwest of Fiji's capital, Suva.

The Contis recognized the stranded boat's name because they'd crossed paths with her a week earlier at Suva, and previously at Niue.

Even though the reef-fringed lagoon where *Océalys* was anchored is adjacent to the populated island of Vatulele, it soon became apparent that the Contis were the only ones listening to the call for help.

"Yeah mate, we're on the reef," explained *Timella's* captain, Cameron Slagle. "The

waves are bashing us pretty hard, but she's a 40-year-old boat and she's built to take a hard landing." At that point, Slagle and his shipmates, fellow Aussie Liz Schoch and New Zealander Ali Timms, were still relatively calm, despite the fact that 35 knot-winds and powerful breakers were lashing *Timella* mercilessly. It had been blowing hard for three days.

The threesome had departed Suva that morning for Kadavu Island, but when their engine quit they realized they couldn't fetch Kadavu under sail alone, so they decided to run with the prevailing wind and current to Veti Levu instead. Unfortunately, an ominous pinnacle reef lay in their path.

The Contis' cool-headed approach to the emergency is truly commendable. After Maurice got *Timella's* exact lat/long position, about 12 miles to the east of *Océalys*, he continually attempted to reach other mariners by relaying the *mayday*.

Meanwhile, Sophie started digging out phone numbers of local resources, while the Conti kids, Massimo, 6, and Annabelle, 4, slept below. She first tried to call the sole resort on the nearby island with her local Fijian cell phone, but realized it had run out of prepaid minutes. She then called with her satphone.

No answer. Next she dialed the local emergency number, 911 — even a 'minuteless' phone can get through to 911. But the operator was obviously unaccustomed to responding to marine emergencies. Nevertheless, she vowed to forward the

request for assistance to the local police as well as the Fijian Navy, and promised a call back. Sophie next found numbers in her Lonely Planet guidebook for the local High Commission offices of both Australia and New Zealand. Both were closed, of course, but a recording's reference to an emergency number resulted in contact with an initially groggy Kiwi, Mike Randall, who quickly became alert when he learned that one of his countrymen was in peril.

"There is no way she's going to be able to hold on. We are definitely sinking, mate."

Anxious minutes turned into hours as the police and Navy attempted to mount a rescue effort. At some point a broken transmis-

sion from a cruise ship was also heard, reporting that she was 30 miles to the south.

Luckily the 'minuteless' cell phone allowed incoming calls. Fijian authorities checked in frequently but gave no solid updates on their efforts to mobilize. Randall, at the New Zealand High Commission in Suva eventually called back to inform the Contis that the New Zealand

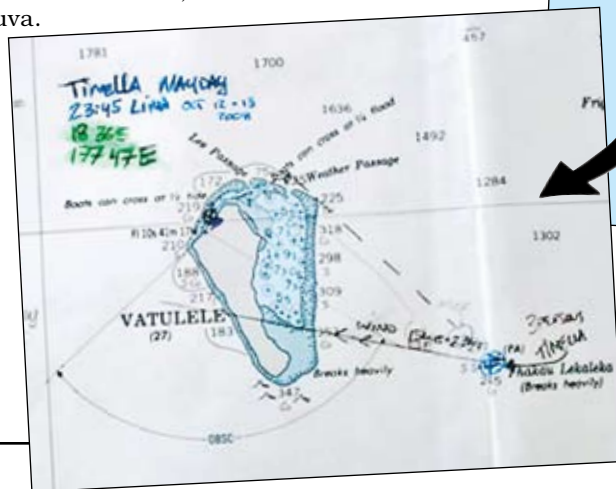

Search and Rescue Coordination Centre was also on the case. Then came another round of calls from the Fijian police and Navy. But still no ETA.

At about 2 a.m. the stranded captain of *Timella* called again by

Océalys TO THE RESCUE

VHF, this time sounding noticeably "stressed" for the first time. His 32-footer was taking on water.

Fifteen minutes later he hailed *Océalys* again. Maurice recalls the transmission vividly: "Ah mate, we're not keeping up with the water. The hole's under the engine, and it's not accessible. There is no way she's going to be able to hold on. We are definitely sinking, mate. We're going to keep pumping as best we can but the batteries are going to be underwater soon."

"I copy that," Maurice replied. "What are you requesting Cameron? We are two and a-half hours away at least and I'm not sure what I can do when we get there."

"No mate, we are requesting an airlift. That's the only way we're getting out of here. Don't put yourself at risk. We're clear on to the reef at this point. They're

not going to be able to get to us by boat. We need an airlift."

"Okay. Roger that. We copy you, request an airlift. Standby and we'll get back to you as soon as possible."

A staffer from New Zealand SAR was soon back on the line, but his reaction to the airlift request was not what Maurice and Sophie were hoping to hear: Fiji currently has no working rescue helicopter.

When *Timella* called again a half hour later there was still no ETA from Search and Rescue in Suva, although they were obviously doing their best to put a plan into action.

This time, the Aussie skipper's message was dire: "We are sinking. The batteries will be under water in a few minutes. We're going to lose contact. We're getting the dinghy out and putting the life raft canister in the dinghy. We've got extra fuel, water and we're getting



PAUL McCULLOCH

After freshening up and a few rejuvenating beers, the survivors struck a pose with their rescuers on Robinson Crusoe Island. Left to right are: Ali Timms, Liz Schoch, Maurice Conti, Cameron Slagle and Sophie Conti.

some food ready."

"Okay, roger that *Timella*," said Maurice. "Do you have any flares?"

"Yeah, they're floating around here somewhere."

"Do you have a handheld VHF?"

"Ah, negative on that. Negative."

"Roger that. We understand that SAR in Suva is mobilizing, but we still have no ETA. You're going to have to hold on a while longer."

During the next 20 minutes more calls came in from both the High Commission in Suva and New Zealand SAR, with the latter advising specific actions that the crew of *Timella* should take, including putting on life jackets and keeping their EPIRB switched on.

At about 3 a.m. the Contis got a final call from the stricken skipper: "We've gone down, mate. I've got water halfway to the cabin top. The batteries are under a meter and a-half of water. I don't know how we're still transmitting." He was still remarkably calm and rational.

Maurice and Sophie somberly weighed

the options. It was clear to them that Suva SAR was not going to launch a rescue effort before dawn, and they were apparently having trouble finding fuel and crew. Maurice estimated it would take a Fijian team five hours to reach the *mayday* location, and New Zealand SAR had had no luck locating other maritime resources in the area. Meanwhile the cruise ship that called earlier clarified that they were actually 130 miles away, and therefore no help. Despite the obvious danger of exiting the lagoon in the dark, Maurice and Sophie decided they had to go to *Timella's* aid, as they were the shipwrecked crew's best — and perhaps *only* — chance of survival.

The stoic Aussie skipper reported, "We're getting into the dinghy and will stay with the boat as long as we can. I don't expect the batteries to hold out much longer."

"Roger that, *Timella*," Maurice replied. "We are coming to you. We will weigh anchor now.

I estimate ETA to your position two and a-half hours. We will stand off the reef and wait for daylight. We may not be able to help, but at least we will be there. Just hold on to the boat."

"We love you man. I definitely owe you a beer or two when this is all over."

Pounding to weather in 25 to 30 knots

"We love you man. I definitely owe you a beer or two when this is all over."

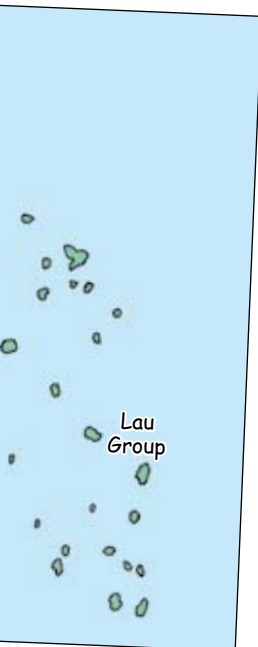

WHO YA GONNA CALL?

of wind was not going to be a picnic. But *Océalys* first had to navigate across the lagoon in the dark and thread her way out through the tricky reef-fringed entrance channel.

Maurice later wrote: "The pass into the lagoon was windy and poorly defined, with shallows and coral heads scattered about. In the dark, the only way to get out was to follow the track we had made on the way in on the GPS." Doing this may sound simple enough, but having done something similar once ourselves over a coral-strewn bottom, we can assure you, it's a utterly nerve-wracking experience.

Although visibility was minimal, Sophie kept watch on the bow as they crept through the pass, trying not to get launched overboard by the incoming swells.

During the slow slog to windward, Sophie spoke again to New Zealand SAR personnel, who confided that the *Contis* were, in fact, *Timella's* only chance.



AUSTIN MCKOWN

The 'Océalys' crew in happier times — all dressed up to honor Neptune during their equator crossing last year.

Océalys arrived outside the Takau Lakaleka reef at 5:30 a.m., just as the sun was rising. The would-be rescuers slowly drove around the circular, half-mile-long reef, but saw no sign of life or wreckage beyond the roaring breakers.

TIPS FROM THE RESCUERS

- Don't rely on help if you get into trouble. Once you leave the North American coast, there may not be anyone babysitting you.
- Even if resources exist, you may not be heard. We were the only station that heard *Timella's* may-day call, and even then by chance since we usually turn the radio off at night.
- Abuse of channel 16 by cruisers is resulting in most boats shutting their radios off at night, if not all the time. To reverse this trend, consider the following: Use ch 16 for emergencies and hailing only (no talking, ever). Wait two minutes between hails. No need to hail four times in 60 seconds. If you hail another boat more than twice a day, pick a working channel.
- Register your EPIRB. Spend the extra money for a unit with GPS. These two things will make a big difference in SAR's ability to find you.
- Do not turn your EPIRB off once you've activated it. *Timella* turned theirs off and back on and their signal was never re-acquired.
- Have a list of relevant phone numbers for your cruising area printed out (preferably laminated) and within reach of your satphone (if you have one). If you're in the South Pacific, you should have the numbers for NZ SAR in Wellington, 011-64-4-577-8030 and the USCG in Hawaii, 808-535-3333.
- A good tourist guide for the country you're cruising (like the Lonely Planet books) will have contact information for local emergency response, hospitals and consulates. Consulates will have a Duty Officer on watch 24 hours a day who is trained to deal with emergency situations in that country.

- Have an exit strategy for every anchorage. You should be able to make your way out in the middle of the night in bad conditions.
- We have found that having all of your navigational data at the helm is critical (chartplotter, depthsounder and radar, if equipped). In an emergency, this information will be mostly useless at the chart table. Without having it at the helm, we would not have been able to pick our way through a winding pass in rough weather until morning, which may have been too late.
- When things get tricky, keep a cool head. Make clear decisions early on and stick to them without second-guessing yourself. When things get really bad: Stop. Breathe. Think. Then act.
- If you put yourself at risk to help someone else or the boat, think about that risk and do what you can to keep from becoming a liability.
- If you're abandoning ship and putting stuff in the water (liferaft, dinghy, supplies, etc.) make sure it's all tied together. *Timella's* crew put everything into the dinghy, which was then torn apart by the falling rig as *Timella* sank. Everything that was in the dinghy was cast adrift.
- We have been surprised at the amount of cellular coverage in the South Pacific. When you're coastal, it pays to buy a \$10-\$30 prepaid SIM chip for your cell phone.
- A charged, handheld VHF could save your life during the last phase of a rescue.
- Stay with the boat.
- Never underestimate the sea. You always have to be "on" out here.

— maurice & sophie

"Suddenly both Sophie and I came to the grim realization that this might not end in the straightforward fashion we had both been imagining."

They decided to make a second lap around the reef, passing as close as they dared to the booming collision of water and coral. After a lot of fruitless searching Maurice glimpsed three black dots in the center of the reef, but they quickly disappeared. As he stared intently at the spot through binoculars, the dots finally reappeared. "They're in the water," Maurice exclaimed, "just bobbing there, waving their arms, meaning they've seen us."

It was obvious to the couple that the only rescue option was for Maurice to make a dash inside with his dinghy and bring them out, despite the obvious risk. Sophie, who is a lifelong sailor from a maritime family, agreed. Having been trained as a rescue diver, Maurice wisely took every precaution in case he, too, became stranded. After putting on his drysuit and harness, he grabbed a handheld VHF, flares, a strobe light, a mask and fins.

Launching the dinghy in the pitching seas wasn't easy, but they managed it. Their Honda outboard fired up on the first pull and Maurice was off, leaving Sophie behind with the kids to hold the boat in position just outside the 15-foot breakers.

After finding a relatively benign spot to cross the outer reef, Maurice zipped safely over the coral and inside the lagoon where he spotted the wreck of *Timella* and her haggard crew, hanging on to their partly deflated dink. In less than two minutes he had them aboard. "A line from some movie I saw once popped into my head, and so to ease the tension a bit I said, "Good morning ladies and gentleman. My name is Maurice and I'll be rescuing you today."

Meanwhile, Sophie had found just the right angle to hold *Océalys* into the swells, so the weary crew could scramble aboard without further injury — not an easy trick for any mariner in such conditions.

Naturally, all three survivors were physically and psychologically exhausted after treading water and bouncing on the reef for hours in the dark. Ali, the thinnest of the three, was suffering from mild hypothermia and had been seriously seasick throughout the ordeal. In addi-

OCEALYS TO THE RESCUE

tion to bruises and coral cuts, Cameron also had second-degree burns on his face and arms from trying to fix *Timella's* uncooperative engine during the trip.

While Maurice set a course for the Robinson Crusoe Island Resort, which lies off the coast of Veti Levu, Sophie got Ali and Liz into hot showers, then into dry clothes and sleeping bags as quickly as possible.

Four hours later they arrived at the island resort, where owner Paul McCulloch, a native Australian, generously offered to feed, clothe and house them until they were ready to make their way home.

It was a harrowing night that none of these sailors will soon forget. In fact, we wouldn't be surprised if they all remain friends for years to come. As Maurice explained, "After sorting *Océalys* out, we went ashore and gave Cameron an opportunity to buy us that beer he had promised, and we toasted to life!"



OCEALYS

'Océalys', seen here tucked into a cozy spot in the Tuamotus. The multihull's inherent stability was a big plus during the rescue.

Sadly, however, *Timella* was unsalvageable and was not insured. She had served as Cameron Slagle's home for the past 8 years. He basically lost everything — but his life.

The New Zealand High Commission

has recommended Maurice and Sophie for heroism awards. But with or without fancy medals, they are surely heroes.

— latitude/andy

Readers — Portions of this article were excerpted from Maurice's complete account of the incident, which can be found at www.ocealys.blogspot.com.

Blue Sky

E N E R G Y

Increase Your Solar Output With Solar Boost™ MPPT Solar Charge Regulators

Get All The Power You Need To Weather Any Storm

The Solar Boost™ 3024i & 2000E are two of the most reliable Solar Charge Controllers on the market & our patented technology extracts all the power your solar panels can deliver, up to 30% more!

Blue Sky Energy Inc. gets rave reviews in *Practical Sailor*. Read the article at www.blueskyenergyinc.com

800-493-7877 or 760-597-1642
2598 Fortune Way, Suite K, Vista, CA 92081 USA
E-mail: sales@blueskyenergyinc.com
Web: blueskyenergyinc.com

QUALITY....RELIABILITY....BLUE SKY ENERGY, CHANGING THE WAY SOLAR IS USED EVERYDAY

CORINTHIAN MIDWINTERS



— BRING THE HEAT



ERIK SIMONSON/WWW.H2OSHOTS.COM

The raft-up started at Little Harding on Saturday when PHRF 1 and 2 arrived at the same time — in a building flood.



The first weekend of the Corinthian YC Midwinters didn't disappoint the nearly 150 starters for weather. Although the breeze never settled in for more than 45 minutes at any point, temps reaching the 70s and non-stop sunshine had sailors practically peeling off layers at every mark rounding.

The Central Bay courses used on Saturday were fraught with massive holes that left entire divisions parked — at times together. That was the case for the first three or four starts. After PHRF 1 got away on time, only to be stymied by little to no breeze and the building flood

tide, a postponement and breeze that built ever so slightly caused the second three divisions to show up at Little Harding at the same time with spinnakers up. In the end, due to overly-optimistic course selection — PHRF 1 got a 14.8-miler — and the massive holes west of Pt. Blunt, four of the 14 divisions didn't count a finisher between them by the 5 p.m. time limit.

Right about then, the sailing layers were being swapped for the evening threads, and sailors descended on the club en masse for the party, free beer, food and make-you-stop-to-admire City

views. As you'd expect, it didn't end there. Tiburon's watering holes must have had a really good night.

On Sunday, those who weren't too damaged from the night before got squared away for another shot at the fickle conditions, and the RC got the course selection squared away — sending all the divisions east through Raccoon Strait on North Bay courses. Nearly every division ended the day with elapsed time spreads in the 2- to 3.5-hour range, and there were very few letter scores in the results. Still, despite a nice, fat puff at the start, there was a big hole and a

CORINTHIAN



ALL PHOTOS LATITUDE/LADONNA EXCEPT WHERE NOTED

restart after the boats exited the Strait. As one person commented: "There's not many things I'd rather be doing than bobbing around out here!"

The next weekend of the Corinthian YC Midwinters is February 21-22, so put off the yard work and tax preparation, re-schedule the visit with your in-laws, and mark the weekend on your calendar.

There are daily trophies, so even if you didn't make the whole thing, you can still bring home some hardware.

— **latitude/rob**

CORINTHIAN YC MIDWINTERS — SATURDAY, 1/17

PHRF 1 (≤ 36)— No Finishers. (13 boats)

PHRF 2 (37-72)— No Finishers. (12 boats)

PHRF 3 (73-108) — 1) **Good And Plenty**, Soverel 33, Will Baylis; 2) **Bufflehead**, Beneteau 36.7, Stuart Scott; 3) **Petard**, Farr 36 mod., Keith Buck/Andy Newell. (17 boats)

PHRF 4 (109-135) — 1) **Arcadia**, Santana 27 (modernized), Gordie Nash; 2) **Uno**, Wyliecat 30, Steve Wanner; 3) **Nancy**, Wyliecat 30, Pat Broderick. (20 boats)

PHRF 5 (136-195) — 1) **Sunda**, Seaborn 35, Bob Rogers; 2) **Wuda Shuda**, Soverel 26, Craig

MIDWINTERS



Clockwise from above — 'Ay Caliente!' with some breathing room; 'Aquavit' enjoys Saturday's best breeze; Sails by Mondrian — 'Tule Fog's patchwork kite; Yeah!'; 'JR' holds off 'Opa!', albeit briefly; Kevin Cole minimized the crew weight aboard 'Dragonfly'; 'Uno' had enough pace to score a 1-2; 'Topgallant' holds a lane underneath 'Seaya'.



PETER LYONS/WWW.LYONSIMAGING.COM



PETER LYONS/WWW.LYONSIMAGING.COM



Page; 3) **Heathcliff**, Catalina 27, Ed Hoff. (13 boats)

PHRF 6 (195-258) — 1) **Can 'O Whoopass**, Cal 20, Richard von Ehrenkrook; 2) **Dragonfly**, Rhodes 19, Kevin Cole; 3) (DNF) **Sweet Reward**, Santana 22, Craig McDow. (3 boats)

EXPRESS 37 — No Finishers. (7 boats)

J/105 — No Finishers. (14 boats)

ALL CATALINA (PHRF 120-180) — 1) **Roe-boat**, Catalina 30, Rod Decker; 2) **Harp**, Catalina

38, Mike Mannix; 3) **Jet Lag**, Catalina 34, Torin Knorr. (12 boats)

ALERION EXPRESS — 1) **Lizbeth**, Michael Land; 2) **Dream**, Kirk Smith; 3) **Flying Machine**, Peter Campfield. (7 boats)

NON-SPIN 1 (PHRF ≤ 114) — 1) **Shockwave**, Santana 35, Michael Bruington; 2) **Q**, Custom Schumacher 40, Glenn Isaacson; 3) **Perserverance**, Beneteau 47.7, Daniel Chador. (11 boats)

NON-SPIN 2 (PHRF 115-177) — 1) **The Kid's**

Table, J/24, Marissa Miller; 2) **Zingara**, Islander 36, Jocelyn Swanson; 3) **Siento El Viento**, C&C 29, Ian Matthew. (4 boats)

NON-SPIN 3 (PHRF 178-273) — 1) **Raccoon**, Cal 20, Jim David/Snow Crowe; 2) **Chica**, Cal 20, Ted Goldbeck; 3) **Sexpialidocious**, Harbor 20, John Colver. (4 boats)

MULTIHULLS (PHRF 135-159) 1) **Caprice**, Seawind 1160, Dan Seifers; 2) **Katiekat**, Seawind 1100, Joe Siudzinski; 3) **Lanikai**, Seawind 1160,

CORINTHIAN MIDWINTERS



LATTITUDE/LADONNA

Multihulls made their Corinthian Mids debut — seven cruising cats showed up.

John Brady. (7 boats)

SUNDAY 1/18

PHRF 1 (≤ 36) — 1) **Diabalita**, 1D35, Gary Boell; 2) **Copernicus**, Sydney 38, Michael Kennedy; 3) **Aboriginal**, Sydney 38, Mark Langer. (13 boats)

PHRF 2 (37-72) — 1) **Sapphire**, Synergy 1000, David Rasmussen; 2) **Comfortably Mumm**, Farr 30, William Erkelens; 3) **Jarlen**, J/35, Robert Bloom. (12 boats)

PHRF 3 (73-108) — 1) **Good And Plenty**, So-

verel 33, Will Baylis; 2) **Ay Caliente!**, Beneteau 36.7, Aaron Kennedy; 3) **Mistral**, Beneteau 36.7, Ed Durbin. (17 boats)

PHRF 4 (109-135) — 1) **Uno**, Wyliecat 30, Steve Wonner; 2) **Nancy**, Wyliecat 30, Pat Broderick; 3) **Silkye**, Wyliecat 30, Steve Seal. (20 boats)

PHRF 5 (136-195) — 1) **JR**, Moore 24, Richard Korman; 2) **Youngster**, IOD, Ron Young; 3) **Wuda Shuda**, Sovarel 26, Craig Page. (14 boats)

PHRF 6 (195-258) — 1) **Can 'O Whoopass**,

Cal 20, Richard von Ehrenkrook; 2) **Dragonfly**, Rhodes 19, Kevin Cole; 3) **Sweet Reward**, Santana 22, Craig McDow. (3 boats)

EXPRESS 37 — 1) **Stewball**, Bob Harford; 2) **Elan**, Bill Riess; 3) **Golden Moon**, Kame Richards. (7 boats)

J/105 — 1) **Roxanne**, Charles James; 2) **Aquavit**, Tim Russell; 3) **Orion**, Gary Kneeland. (14 boats)

ALL CATALINA (PHRF 120-180) — 1) **Harp**, Catalina 38, Mike Mannix; 2) **Jet Lag**, Catalina 34, Torin Knorr; 3) **Roeboat**, Catalina 30, Rod Decker. (13 boats)

ALERION EXPRESS — 1) **Spirit**, Nancy Rogers; 2) **Dream**, Kirk Smith. (7 boats, 2 finishers)

NON-SPIN 1 (PHRF ≤ 114) — 1) **QE 3**, Tartan 10, Tom Perot; 2) **Shockwave**, Santana 35, Michale Bruington; 3) **Luna**, Antrim 27, Trig Lijestrland. (12 boats)

NON-SPIN 2 (PHRF 115-177) — 1) **Siento El Viento**, C&C 29, Ian Matthew; 2) **Windhover**, Pearson 10M, John Dodge. (4 boats, 2 finishers)

NON-SPIN 3 (PHRF 178-273) — 1) **Sexpialicious**, Harbor 20, John Colver; 2) **Tension II**, Cal 20, John Nootboom; 3) **Raccoon**, Cal 20, Jim David/Snow Crowe. (5 boats)

MULTIHULLS (PHRF 135-159) 1) **Serenity**, Seawind 1160, Michael Ropers; 2) **Caprice**, Seawind 1160, Dan Seifers; 3) **Bluewater**, Catamaran, Gary Helms. (7 boats)

For complete results: www.cyc.org.

Keep Racing with Hogin Sails

We build custom sails to suit your needs,
offshore or around the buoys.

Call us
about our Winter
Discounts



Mark Howe's Beneteau 40.7 'White Fang' (28187) blasts down the Cityfront during the 2008 Big Boat Series.



- New racing or cruising sails
- Roller furling conversions
- Repair and service
- Boom and canvas covers
- Dealer for Nauteek compass/GPS electronics, Strong Track mainsail tracks and ATN spinnaker sleeves

In the Alameda Marina at
1801-D Clement Ave., Alameda, CA 94501

510.523.4388

Mon-Fri 8:30am to 5pm, Saturday by appointment only

sales@hoginsails.com • service@hoginsails.com

www.hoginsails.com

We put you on a silver platter.



"The Raceware Specialists"

www.APSLTD.com

800.729.9767

JOIN US FOR OUR MIDWINTER SERIES

★ ALL BOATS WELCOME ★

February 21-22

*Post-Race Festivities – Drink, Dine
and Dance to the Left Coast All Stars*
Information & Sign-Up at: www.cyc.org

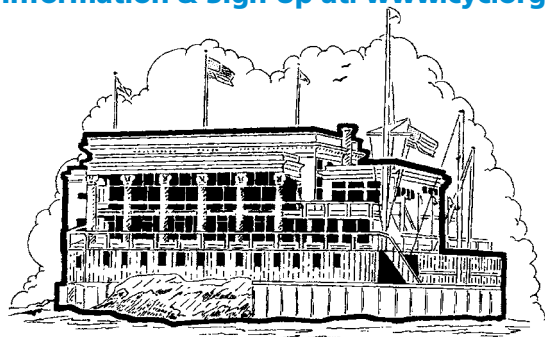

Corinthian Yacht Club

OF SAN FRANCISCO

43 MAIN, TIBURON, CA 94920 • (415) 435-4771

Visit our website: www.cyc.org

Ballenger Spar Systems, Inc.

**Custom Racing and Cruising Spars
Expert Design and Consultation**

- Carbon and Aluminum spars
- Rod and wire rigging
- Hi-tech and conventional halyards
- Spar kits, extrusion
- Repair and modification
- Custom fabrication, waterjet and CNC
- Hardware, sheaves, spreaders
- Bay Area pick-up and delivery
- *Discounts* on halyards, standing rigging, deck hardware, furlers, Navtec integral cylinders
- 35 years experience!

***Call about Carbon Spars.
Masts • Booms • Poles***

ballengerspars.com

831/763-1196

831/763-1198 (fax)

EYE ON THE BAY

LATITUDE / LADONNA



Hook 'em when they're young — sailing is a great family activity.

LATITUDE / ROB



LATITUDE / ROB



'Manu Kai's crew relaxes while the cruising chute flies.

"**H**ope is a thing with feathers," wrote Emily Dickinson. And as America welcomed its new leader last month, many Americans also dared to welcome "the little bird that kept so many warm."

Instead of allowing their boats to molder away in a marina while they worried about things beyond their control, dozens upon dozens of Bay Area sailors wisely exploited their maritime investments to their fullest potential, shaking

Spread, sailing the Bay is a dream come true for 'La Soñadora'.

out their sails in an unprecedented display of hope . . . mostly for wind.

After a chilly start, January turned surprisingly warm, with the sun shining brightly throughout most of the month. For about a week in the middle, some sailors were wishing summers would be so delightful.

But lovely winter weather usually means light winds across the Bay, and last month was no exception. Racers may have been cursing their fates but cruisers seemed to enjoy the mellow atmosphere, as evidenced by the sheer numbers of boats plying the waters every weekend.

If you have loved ones who flatly refuse to sail "tipped over," then winter

LATITUDE / LADONNA

— HOPE SPRINGS ETERNAL



Here's hoping for more sunny weather.



EYE ON THE BAY

PETER LYONS / WWW.LYONSIMAGING.COM



LATITUDE / LADONNA



LATITUDE / ROB

— HOPE SPRINGS ETERNAL



LATITUDE / JR

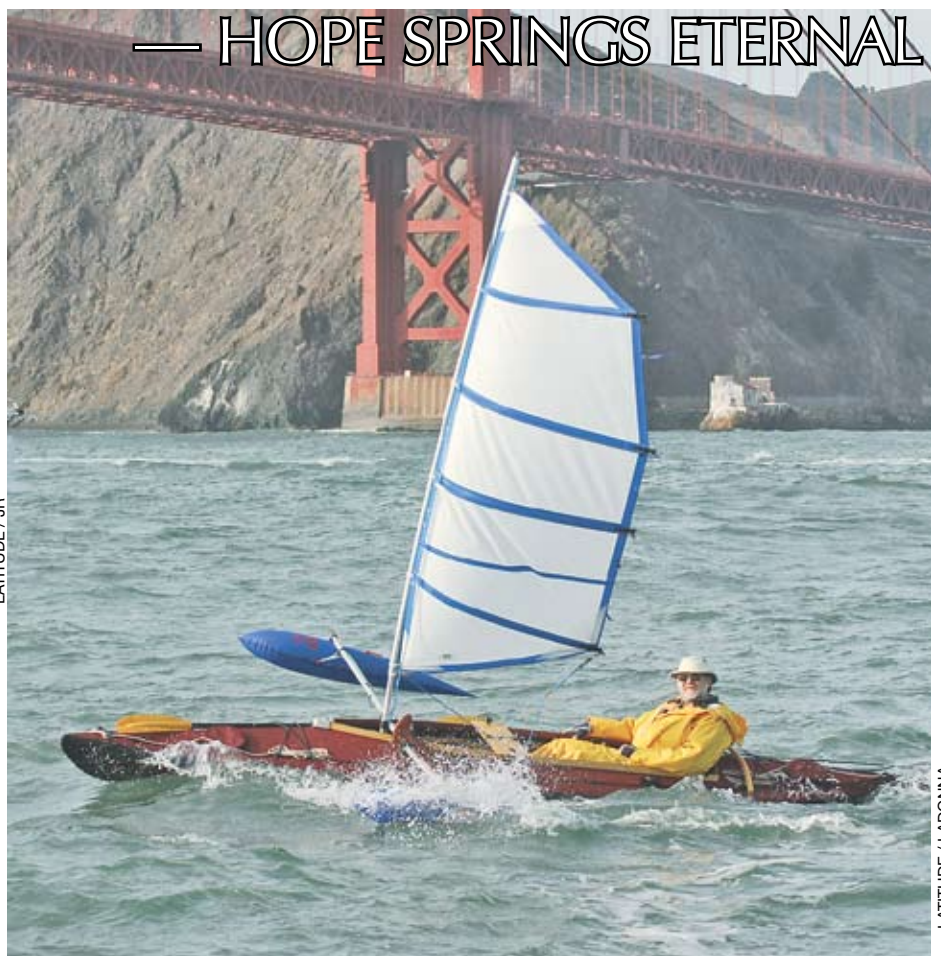

LATITUDE / LADONNA



All sorts of hopin' goin' on — Bay Area sailors thumbed their noses at the grim economy and took to the water in droves last month. As they can tell you, nothing raises your spirits better than a great sail on a warm day. Clockwise from below: The Bob Perry custom-designed schooner 'Jakatan' doing what she was built for — sailing the Bay in style and comfort; 'Wanderin' Bear' gets ready to watch the sun set over the Golden Gate; the folks aboard 'Fort Knots' find fun on a fabulous day; the first mate on 'Chris Anne' stands watch; "What, me worry?"; if you don't own a sailboat, just turn your kayak into an outrigger.



LATITUDE / LADONNA

EYE ON THE BAY

provides a perfect opportunity to get them aboard for some mild and lazy sailing.

Pack a picnic lunch, grab your best gal, and set off on a circumnavigation of Angel Island. As you pass Ayala Cove, pull into the guest docks and take a walk around the island. You'll be pleasantly surprised at how quickly it's recovering from the devastating wildfire that tore across its southern half last October.

If you're in the mood for a little high life, scoot on over to the City and tie up for free at Pier 1½, next door to the Ferry Building, while you do a little shopping and grab some lunch. Or arrange for a night's moorage at a Cityfront marina and hit a comedy club. The total cost for the evening will be cheaper than a single night in a hotel *and* you won't have to worry about when the bedspread was last washed.

Sometimes it's nice to get away from



"Emily who?" We doubt Dickinson was a sailor, but we bet she would have loved it.

it all, though. The next time you're in a minimalist mood, spend the night on the hook. Richardson Bay, Clipper Cove, Redwood Creek — the exact location doesn't matter as much as the state of relaxation you'll find yourself in when you kick back with your favorite beverage and a good book. And don't worry if your boat isn't equipped with a heater — cool evenings are a great excuse to cuddle.

If you don't feel like taking the boat out at all, coordinate an impromptu potluck on your dock. Few things cap off a busy workday better than sharing a drink and a bite with friends aboard your boat on an unusually warm winter evening.

In these tough financial times, it just doesn't make economic sense to let your boat sit idly in her slip. If you've got a boat, use it. If you don't have a boat, find someone who does — post your name on a marina bulletin board, walk the docks on a busy Saturday and, most importantly, add your name to *Latitude's* free online Crew List (see *Sightings* for details).

Even if you have to force yourself to get out there, remember that, while Dickinson's little bird "never asked a crumb," just a little extra effort to feed it helps keep hope alive.

— **latitude 38**/ladonna

BUSY...AND THANKFUL

Easom Rigging wants to thank the many customers who are keeping us busy in a challenging time.

Why are we busy now?

- VALUE - It's never been more important. Try us and see.
- 30 Years in Business - Thank you to our many long-term customers.
- Specialists - Rigging isn't part of our business, it's our only business, so it will be the best.
- Hard Work - Nobody works harder to provide great quality at always reasonable prices.

We are truly grateful to be busy now and invite anyone to experience why!

Give a call today.



Easom Racing and Rigging

1150 Brickyard Cove Rd. Suite B1
Point Richmond, CA 94801

(510) 232-SAIL (7245)

www.easomrigging.com

SCHOONMAKER POINT MARINA

• IN SAUSALITO •



Call the Marina Office
for more information

415•331•5550

FAX 415•331•8523

or check our web site at
www.schoonmakermarina.com

85 LIBERTY SHIP WAY, #205
SAUSALITO, CA 94965



160 Berth Marina in one of the most beautiful spots on the Bay

- Visitor berths • Guest moorage able to handle yachts up to 200 ft.
- Dry storage • Waterfront Offices • Three-ton Hoist • Windsurfing
- Deli • Beach • Rowing • Kayaking • Yacht clubs always welcome



Catalina 320, *Four Winds*

STARBUCK



CANVAS WORKS

**...Unless You
Just Don't
Care.**

67 Liberty Ship Way
Sausalito, CA 94965

415•332•2509



Safe Voyages Begin with Landfall

Whether you're headed out around the mark, the Farallons or down to Mexico, Landfall has what you need to get home safely – from PFDs to GPS, including foul weather gear, cruising guides, charts, chips and more.

Give us a call. Our knowledgeable specialists will be happy to offer personal help with all your outfitting needs. For more info or a free catalog, call **800-941-2219**. Shop online anytime: www.landfallnav.com

 **Landfall**[™]
WHERE SAFE VOYAGES BEGIN

SAFETY | NAVIGATION | REFERENCE | WEAR

©2009 Landfall Navigation. All rights reserved.

BALCLUTHA

*They mark our passage as a race of men —
Earth will not see such ships as those again.*
— John Masefield

The Grand Dame of the Bay is in for her once-a-decade makeover. We're talking about *Balclutha*, the 301-ft LOA centerpiece of the San Francisco Maritime National Historical Park, located at the foot of Hyde Street in the City. Queen of the seven-ship historic fleet, *Balclutha* is one of the last and largest full-riggers on display on the West Coast. (The only others are San Diego's *Star of India* and Honolulu's *Falls of Clyde*) — and one of the most interesting.

Launched in Glasgow in 1886, *Balclutha* (from *baile clutha*, gaelic for 'town on the Clyde', a reference to Dumbarton) made her maiden voyage the next year, carrying coal from Cardiff to San Francisco. She carried sacks of wheat grain for her trip back home. Although she visited other ports around the world, the

sea general' (tinplate, coke and pig iron) and, of course, lots of Scotch whiskey.

In 1899, *Balclutha* was transferred to Hawaiian registry and joined the bustling Pacific Coast lumber trade. For three years, the ship carried lumber from the Pacific Northwest to Australia — 1.5 million board feet in all. Much of it ended up underground as mining timbers in the Broken Hill Mine, a mother lode in the Outback so rich in silver and lead ore that it's still producing today. *Balclutha* became the last vessel to fly the flag of the Kingdom of Hawaii.

In 1901, a special act of Congress admitted foreign-made ships into American registry. (Before that, only ships captured during wartime could become 'American'.) A few years later, *Balclutha* became part of the last great American sailing fleets, the Alaska Packers.

The Alaska Packers Association caught, canned and transported salmon. Although steam power had already taken over most trade routes at the turn of the 20th Century, the salmon business was seasonal and sail still made economic sense, especially since old sailing ships were cheap and available. How cheap? After *Balclutha* went aground in 1904, the Packers bought her for \$500! They pulled her off, fixed her up and put her to work.

The Alaska Packers ships would sail north with men and supplies in April, anchor off one of the company's canneries with a skeleton crew for the summer, and return south in September with holds typically filled with 2.5 million cans of



BALCLUTHA AT A GLANCE

LOA	301 ft
LOD	256.5 ft
Beam	38.6 ft
Depth	22.7 ft
Displacement	4,100 tons
Mainmast	145 ft
Sails	25
Sail Area	25,000 ft ²
Crew:	26

salmon. Here in the Bay, the fleet rafted up and wintered in the Alameda Estuary, where any needed work was done.

The Packers named all their canneries after diamonds and all their ships after stars and countries. *Balclutha*, one of the first members of the 'star fleet', became *Star of Alaska*.

As the years went by, and the salmon business became more profitable, the Packers began replacing their sailing ships with steam powered ones. When *Star of Alaska* sailed north in the spring of 1930, she was the only sailing ship in attendance. She was retired upon her return to the Bay later that year.

Of the 14 sailing ships in the Alaska



A little off around the ears, please — 'Balclutha' in drydock prior to her bottom getting sand-blasted and painted

Europe-to-San Francisco run figured prominently in her early years, with such varied cargos as pottery, cutlery, 'Swan-

ERIC BALDERSTON/COURTESY BAY SHIP AND YACHT



Above, 'Star of Alaska' ('Balclutha') under sail off the Golden Gate during her Alaska Packer days. Although it's unlikely she'll ever sail again, even under tug power (right), the sight of her underway last month still stirred the heart.

Packers fleet, only *Balclutha* and *Star of India* (ex-*Euterpe*) survive. If you scuba dive, you can still visit one more — the *Star of Russia* remains a popular wreck site off Vanuatu.

The next chapter in *Balclutha*'s life saw her become a true 'star'. In 1933, an enterprising fellow named Frank Kissinger purchased *Star of Alaska* for \$5,000, renamed her *Pacific Queen* and towed her down to Catalina Island. There the anchored ship appeared in some scenes from the Clark Gable-Charles Laughton version of *Mutiny on the Bounty*, which

went on to win the Oscar for best picture in 1935.

For a time thereafter, Kissinger towed the ship up and down the West Coast, either playing off the *Bounty* notoriety or exhibiting her as a 'pirate ship.' During this period, without proper care, the ship slowly deteriorated. She barely escaped World War II scrap metal drives.

In 1954, largely through an effort spearheaded by Director Karl Kortum, the San Francisco Maritime Museum purchased *Pacific Queen* for \$25,000. Assisted by donations of cash, materi-

als and labor from the local community, the Museum restored the vessel and returned her original name. *Balclutha* was transferred to the National Park Service in 1978, and designated a National Historic Landmark in 1985.

Early last month, the 122-year-old ship took rare leave of her dock at Hyde Street Pier for the short, tug-assisted voyage to Bay Ship and Yacht in Alam-

ALL IN THE FAMILY

In the days of commercial sail, only the Master, whose wife sometimes accompanied him, had any opportunity for family life. On *Balclutha*'s last voyage under the British flag, Captain Alfred Durkee's wife, Alice, gave birth to a daughter. They named the little girl Inda Frances because she was born on the Indian Ocean while the ship was bound for San Francisco.

There she was 'hailed out' on a floating drydock for three weeks of maintenance and repairs, including extensive recaulking of leaky decks; rigging work; removal, sandblasting and repainting of her masts and yards; and a bottom job. The latter was preceded by ultrasonic testing of her riveted steel hull. All in all, "She is in amazing condition for a ship her age," said shipyard General Manager

SAN FRANCISCO MARITIME HISTORICAL PARK



JACK C. GOLDTHORPE

Bill Elliott.

The \$1 million shave and haircut (paid for by the San Francisco Maritime Historical Park) was expected to take about three weeks. By the time you read this, *Balclutha* will likely be back at her spot at Hyde Street Pier, ready to embark another cargo of visitors to the faraway ports of a time long gone.

— latitude/jr

JOHNSTON ATOLL

We departed Honolulu's Ala Wai small boat harbor on warm, hazy morning, sailing a rhumbline in light winds for



Ken and Katie Stuber in Hawaii. The couple sailed 'Sand Dollar' out the Golden Gate last June. They're presently in Majuro.

Majuro, Marshall Islands, 2,000 miles to our southwest. Six days later, sailing wing-and-wing downwind in roly seas on our Bristol 32 *Sand Dollar*, we had amassed a small crisis of needed repairs. The refrigerator was acting up; Bob the auto pilot quit after a particularly squally night, and — highest priority — we had broken a sail slide on the mainsail. The only land nearby was little Johnston Atoll. Since it was dead ahead, we decided to put in there to sort ourselves out.

Although Johnston Island was first seen in 1796 by the American brig *Sally*, it is so desolate and remote that it remained uninhabited for long after that. In 1926, the U.S. Department of Agriculture declared it a bird refuge. And in the 1930s, with war on the horizon, the Navy saw it as an "unsinkable aircraft carrier" and constructed an airfield a few years later.

Early in the war, Johnston Island, one of four islands that make up Johnston Atoll, was a base for both fighter and anti-submarine aircraft. Later, it became a refueling stop for submarines and other types of aircraft. After the war, the atoll played varied Defense Department roles, including use by the Defense Nuclear Agency for atmospheric nuclear weapons testing in the early 1960s. Later, the U.S. Coast Guard operated and maintained

a LORAN-C station here.

That program ended in 1963, but Johnston Atoll was maintained and staffed in a state of readiness. After the Viet Nam war, the army used the island to decontaminate and dispose of chemical weapons such as Agent Orange. The island was also utilized as a storage facility for nuclear weapons.

The military pulled up stakes (literally) a few years ago, leaving behind only an eight-story, solid concrete, windowless building that had been built to withstand the forces of long-range missile launches. It also withstood the forces of hurricane *Ioke* in 2006. It currently serves as shelter for the crew of the research vessel *MV Searcher* on their regular visits. This structure can be seen from miles out to sea.

The military dismantled and razed all the other buildings, hauled away or buried all construction materials, removed the chemical contaminants, and sealed or destroyed all of the bunkers. The only signs of their existence are the concrete slab foundations for the many barracks and out-buildings. Aside from these and the ruined bunkers, very little else remains. The birds, once again free to move about the atoll, have returned in impressive numbers.

We carry charts of everything on our planned routes 'just in case.' and thus had a chart for Johnston Atoll. We followed the well marked channel into the lagoon



and were surprised to find another 'left-over' — some small boat docks in quite serviceable condition. We tied up and stretched our legs on terra firma. Ken rigged up a clothesline to air our bedding, but not for long. After one of the birdie locals left a deposit, we decided the linen had been aired enough!

Tied to a ship dock a few hundred yards west of us was the only other boat here, the *MV Searcher*, a privately chartered research vessel out of Honolulu. She carried a small crew, a few members of the research team, a gentleman named Todd from the Air Force, and a dog. Todd was there as the USAF representative to insure that military interests and restrictions were observed.

Johnston Atoll is now and always has been strictly off-limits to civilians. Todd walked over to greet us shortly after our arrival. He was very pleasant, gave us a little history of the atoll, took our names, and told us we were welcome to complete our repairs before getting underway

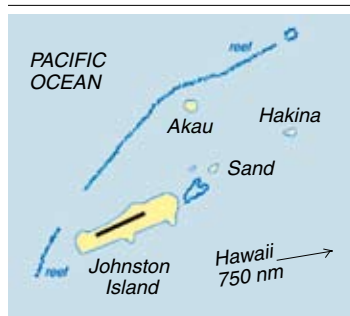

Johnston Atoll is an unincorporated U.S. territory administered by the Department of Interior. It is presently part of the U.S. Pacific Island Wildlife Refuge. In 1942, coral dredgings were used to expand Johnston Island from 50 acres to almost 600 acres, to make room for the airstrip and base.

INTERLUDE



times for a quick photo-op.

Far from seeming uncomfortable with our presence, the little fairy terns appeared to be intensely curious about us. These little guys are all white, with a barely noticeable band of dark blue on their beaks, and eyes like bright black beads. They followed us everywhere, often only inches above our heads, and would even fly ahead of us and turn around to hover backward, facing us, as if trying to figure out what on earth we were. Their approach to motherhood is the ultimate in low maintenance — they build no nests at all, and although we saw one egg laid on a big branch, the preferred procedure seems to be to lay a single egg on a block of concrete right out in the open. Not particularly warm and fuzzy as nurseries go! Poor hatchling, Hard cement, hot sun; evidently the system works, though, because there sure were a bunch of fairy terns flying around.

Also everywhere — flying, squawking, nesting and pooping — were red-footed boobies. They are white with black trim on their wings, pale blue beaks

'Sand Dollar' at the surprisingly modern — and completely deserted — docks at Johnston Island.

again. Todd and the research scientists were much in evidence during our few days on Johnston Island. They rode bicycles and puttied around in golf carts, setting up little stations for surveys or for collecting and testing ground water.

As a bird refuge, Johnston Atoll is thriving. The island is full of rookeries and the birds are everywhere. The largest resident is the magnificent frigate bird, whose 6-ft wingspan and forked tail make him distinctive in flight. The male has a red throat pouch that he can inflate with air until it balloons up to the size of a softball. We first thought this was some sign of aggression and took pains to keep our distance. It turns out, however, that it is part of their courtship ritual so apparently it is his "come-hither" look.

The frigate birds make their twig nests in either branches of low bushes or on the ground under a bush. This

sometimes makes them tricky to see, and in thickly populated neighborhoods, we'd occasionally pass too close for the mother bird's comfort. When this hap-



pened, mom would warn us off by clacking her beak with a sound reminiscent of castanets. All in all, none of the birds on Johnston seemed threatened by us and we took care to maintain a respectful distance, edging in close only a few

and, as the name says, red feet. They are the clowns of the bird world, with both eyes in the front of their heads, making for a very comical appearance when they



Guano was once 'mined' on Johnston Island and there're still lots of it. Native species include the frigate bird, left, and fairy tern, above.

looked straight at us. There were two nearly-leafless trees by our dock, and the boobies would gather there every morning. Although both trees looked the same to us, the boobies obviously preferred one in particular, arguing loudly

JOHNSTON ATOLL

ALL PHOTOS KEN AND KATIE STUBER

and pushing each other off the favored branches, while the other tree sat empty a few inches away.

Another atoll resident was the lovely and graceful red-tailed tropicbird. She's a primarily white bird about 2 1/2 feet long, including tail, with black trim on her wings, a little black mask, and a long, red tail streamer. She builds a twig nest on the ground in the shade of dense



The 90-ft Hawaii-based 'Searcher' is occasionally chartered to take scientists to Johnston Atoll for environmental or wildlife research.

underbrush. We happened upon a little group of about six of them nesting and although we kept our distance, no one

in the maternity ward seemed the least bit upset by our proximity. One mommy even let us photograph her chick with nary a ruffled feather or word of protest.

Shearwaters were also in evidence around the island, but they tunnel in the sand to nest, and we heard that their rookery is on one of the other islands in the atoll.

The water around the atoll is crystal-clear, in shades of blue, green and turquoise. Lots of colorful aquatic life swam around the boat: orange-spine unicornfish, yellow tang, bluefin trevally, and butterfly fish to name a few. There were hundreds of crabs and we once spotted a large sea turtle off the stern. Curiously,

OFF LIMITS, EVEN IF YOU'RE FAMOUS

Johnston Island is off-limits to visitors but you are allowed to stop for emergencies or repairs. William F. Buckley learned this the hard way in 1982. He was headed to the South Pacific aboard the chartered Ocean 71 *Sealestial* and stopped at Johnson Atoll for a visit. He was asked to leave immediately. When Buckley tried to argue that he was a good friend of President Reagan and that his wife was spending the weekend with the first lady at that very moment, the base commander replied, "Sir, I don't care if you're Reagan himself. You're not getting on this island." And he didn't.

there were no barnacles growing on the seawalls. We likewise saw no evidence of any predators. Except for the birds and aquatic life, the only other critter we saw was a single, one-inch-long dead mouse. There were almost no bugs, but a large black bumblebee took an interest in us and visited the cockpit every

morning.

With repairs completed in a few days, we enjoyed our last sundowners in the shade of the little NOAA tide station and resumed our passage on yet another bright sunny morning. Our unplanned stop at Johnston Atoll proved to be more than just 'rest and repair.' It was truly a rare and wonderful treat.

— Katie Stuber

New Member Showers and Laundry Facilities Now Open!

NEW SLIPS!

Available Fall/Winter 2009
Now taking reservations for 40' to 60'

Emeryville Marina

ON THE BAY

When you call Emeryville Marina Home...
...call this your backyard!

Slips from 20-65 ft
Full Amenities - including
Fuel Dock & Pumpout Station



MARINAS[™]

International

(510) 654-3716

www.emeryvillemarina.com



Cruise TAHITI & FRENCH POLYNESIA

aboard the
LUXURY TALL SHIP
Star Flyer

A *sailing* experience,
where the work
is optional!



Book prior to March 31 and you will FLY FREE on selected sailings through August. (Fly Free offer applies to Air Tahiti Nui flights from Los Angeles.)

Enjoy the highlights of these amazing South Pacific Islands: Papeete, Moorea, Bora Bora, Raiatea and more! Cruise for 7, 10 or 11 nights with plenty of time ashore to snorkel, swim or scuba dive in the world's most magnificent, pristine waters. The 170-passenger Star Flyer is a gorgeous 360-ft long, 3-masted Barkentine-rigged sailing ship. Check the web site for a video, virtual tour of the ship, and more details: www.starclippers.com

For inquiries, reservations or a **FREE BROCHURE**, call:

Special Clipper Ship Instructions:
Hands-On Sailing Maneuvers on Deck
Knotting Classes • Navigation Classes
Dinghy & Laser Sailing

THE CRUISE DIRECTOR, INC.
(650) 592-6048 (800) 533-7111
email: off2sea@pacbell.net



California Seller of Travel
#1002066-40

MORE FUN. LESS FUEL.



- Quiet, 4-stroke technology
- Unsurpassed fuel economy
- Transistorized pointless ignition
- Ideal for sailboats, small tenders

IDEAL FOR
SAILBOATS
AND SMALL
TENDERS

POWERED BY

**HONDA
MARINE**

Meets EPA
2006 & CARB
2008
Emissions
Standards!

© 2008 American Honda Motor Co., Inc.

Always wear a personal flotation device while boating and read your owner's manual.
5-year warranty standard on all new Honda outboard engines purchased.
Check with participating dealers for complete details.

POWERED BY

**HONDA
MARINE**

**ENGINE
SERVICE SPECIALISTS**
Upgrade • Repower
Maintain

DORY
POWERED BY HONDA

BOSTON
WHALER

Universal
DIESEL MARINE ENGINES

Outboard Motor Shop
Where the professionals shop!

(formerly Seapower Marine)

(510) 533-9290

www.outboardmotorshop.com

333 Kennedy St., Oakland, CA 94606 • Fax 510-533-3374

Come See Our Showroom at Our New Waterfront Location

REPOWER • SERVICE • REPAIR
CUSTOM MECHANICAL & ELECTRICAL SYSTEMS



See us at

Strictly Sail
PACIFIC
Jack London Square
April 15-19

HIRSCHFELD YACHT LLC

Your California specialist for

BETA MARINE

39 Libertyship Way, Sausalito, CA 94965

(415) 332-3507

www.engerite.com • www.betamarinewest.com

THE HIDDEN LIVES

At first glance, the life of a harbor-master might not seem that exciting. After all, aren't they basically pseudo landlords — like the people who run those dry storage places, except it's wet storage? Sure, they'll occasionally retie a frayed dockline for you, or tell those noisy neighbors to quiet down. But mostly, when they're not busy collecting rent, they're just sitting in their offices pushing paper around.

Right?

Wrong.

We've met and known lots of harbor-masters over the years, and a few have become good friends. The majority of them are smart, energetic, glass-is-half-full kind of folks. Most love what they do, and many have been doing it for 20 or 30 years. And their stories! You couldn't make this stuff up if you tried. Here are a few glimpses into the 'hidden life' of harbor-masters — all real incidents, all happened right here in the Bay Area.

Yes, a good part of a typical harbor-master's weekly routine is dealing with tenant complaints: so-and-so took my hose and didn't return it; those people on thus-and-such boat are playing music too loud; or the halyard on the boat next door is slapping.

Occasionally, there's a fresh twist on the theme, such as the one involving a well-known San Francisco restaurant whose windows looked out onto a marina. One night the patrons got a bit more ambiance than they'd bargained for: some boaters in the marina were using a sail as a movie screen and the film was, shall we say, 'not appropriate for children.' The restaurant called the harbor-

master who discovered it was a bunch of young guys throwing a bachelor party for their friend. Increasing the embarrass-

ment quotient, the harbor-master in this case was a woman, Pier 39's Sheila Chandor. "They were all very apologetic, very embarrassed, and stopped immedi-

ately," she recalls.

Alarms going off are also common. Many modern boats are festooned with alarms — for fire, carbon monoxide, high water, low oil pressure, etc. People often leave them on when they leave the boat, and every so often they go off. Unless the boat is obviously sinking or on fire, the harbor-master has to play a bit of a guessing game as to why.

"The first thing we do is call the owner," says Marina Village's Alan Weaver. "If it's not an emergency, they'll often come down to deal with it." Fortunately, most of the alarms turn out to be something benign. Probably the most common alarm heard in a marina is for carbon monoxide, which can build up inside a closed up boat while charging (or over-charging) batteries.

Another alarm, heard regularly during the extreme tides of winter, is for shallow water. Boaters set these while underway to alert them when they're getting into shallow areas. And they forget to turn them off. So sometimes, during an extreme low tide, the water under a parked boat gets so 'thin' that the alarm goes off.

Fire in a marina (like this one in Ensenada) is a harbor-master's worst nightmare. If there's time, burning boats are often untied and cast off to prevent the fire from spreading.

"Sea lions are smart — and they have a great sense of humor."

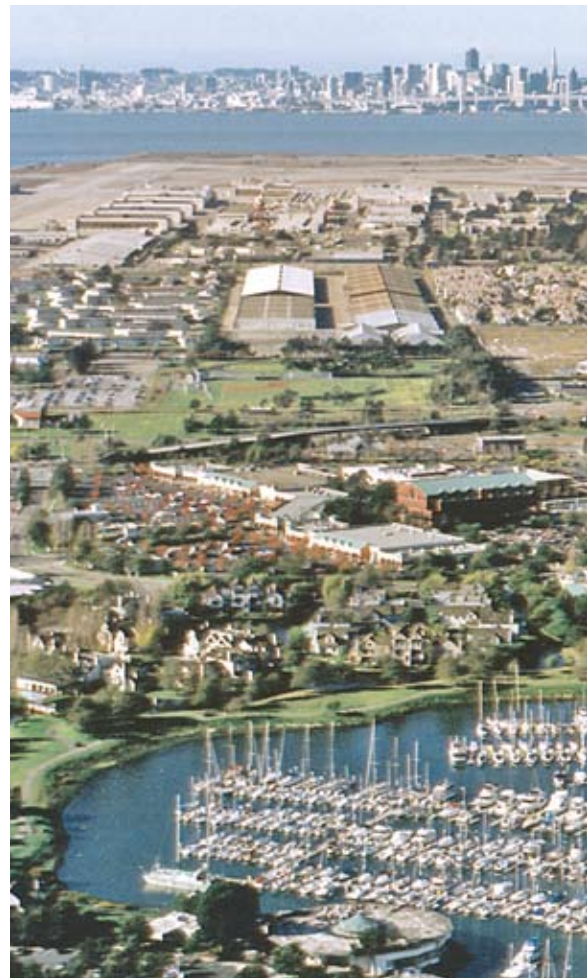

In a large marina, this can mean multiple alarms going off around the same time each day — a bit like what happens in a clock shop at high noon.

Occasionally, alarms signal a real emergency. Most harbor-masters have stories about boats that sank or almost sank at their slips, and a few have fought fires aboard parked boats. "One guy told me over the phone that he thought it must be the fire alarm going off," says Weaver. "He said, 'I guess you'll have to cut the lock to turn off the alarm. And I'd appreciate it if you'd check for a fire while you're down there.'" No problem, sir.

Actual boat fires in a marina are, in the words of Vallejo Municipal Marina's Jim Hausener, "a harbor-master's worst nightmare." They are often hard to fight, they can spread to neighboring boats or docks, and there can



LYNN BRADSHAW

OF HARBORMASTERS



for him to rendezvous with them and take over the tow of a disabled fishing boat they were bringing in from the ocean. This he did. Soon after getting the fishermen tied up to the dock, he got another call from the cutter. They had somehow managed to get the towline wrapped in their prop and had drifted into the breakwater. So he pulled that 82-footer off and towed them in, too.

Some calls are almost always false alarms, even though the callers mean well — like the ones that used to come in to the San Leandro Marina years ago about people aground in the mudflats. Seems there used to be a duck blind out on the flats, secured in place by several pilings. But what it *looked* like, from a distance, was a beached boat, and the pilings looked like people. Of course, every so often a boat really would run aground there, so whenever they got *that* call, the marina would always dispatch a boat and go check, just to make sure.

Boat sinkings in marinas are still a fairly common occurrence, although not nearly so common as even 10 or 15 years ago (due in part to bilge alarms). Still, most larger marinas average one or two sinkings a year, and the harbormaster usually ends up being to the go-to guy or gal who arranges the raising, pump out, pollution control, tow to a yard and owner liaison.

While storms and neglect sink their share of boats, most at-the-dock sinkings are caused by owners. And we're talking about well-meaning folks who make a small but crucial mistake in maintaining their boats, such as the owner of a big

Seagull's eye view of Alameda looking west toward the Golden Gate. Marina Village Yacht Harbor is in the foreground. It looks calm and peaceful here, but a harbormaster never knows what's in store when he or she arrives at work in the morning. One told us of finding a boat at the guest dock that hadn't been there the previous night. Not only that — it had sunk. A call to the Coast Guard revealed they had towed it in and "It was fine when we dropped it off." The owner was broke and couldn't pay for anything. Soon after that, who shows up but those guys from 'Mythbusters', looking for a boat to mangle on their TV show. They paid to raise it and truck it away — and later proved conclusively that the ancient Romans could NOT set ships afire with huge mirrors.

be more than a little personal danger involved. Jim remembers one years ago that had started in the bow of an old powerboat. When the fire was suppressed enough that he could finally get aboard and hit it from the inside, the smoke cleared to reveal that the owner had put several portable fuel tanks — *full* fuel tanks — in the bow. "I've always wondered how close I came to blowing myself up that day," says Jim.

Even farther back in time, Hausener became something of a hero during a big fire at the Mare Island Navy yard. A creosote-saturated wooden pier had caught fire, and during the battle to put it out, a fireman fell through the burning pier into the water.

Jim had the only boat small enough to get under there — a small aluminum runabout — and managed to maneuver under the burning dock to make the rescue. "We *both* had to change our underwear after that one!" he laughs.

Most calls for assistance are more benign. And most of those are people requesting tows. Depending on where they've worked, some harbormasters have towed several hundred boats over the course of their

careers. A particularly memorable day for Hausener occurred back in the '80s when he was the harbormaster at Pillar Point. A Coast Guard cutter had called

One tenant managed to get stuck at the top of his mast — naked.

COURTESY MARINA VILLAGE YACHT HARBOR



SHEILA CHANDORPIER 39

At Pier 39, Monterey and a few other places, harbormasters wage a constant battle to keep sea lions off boat docks — and boats.

motorboat that sank at Marina Village a few years ago. Alan Weaver phoned the owner with the bad news the next day

THE HIDDEN LIVES

and the guy said, "That's funny, I was just down there working on the head yesterday."

Turns out he had removed the head to rebuild it, and tucked one of the hoses up out of the way. After he left the boat, the hose had fallen down. Since it was attached to a thruhull below the waterline — and the thruhull had not been turned off — the boat filled and sank.

But as with any endeavor, it's primarily the 'live ones' — the people themselves — that are a neverending source of entertainment for harbor masters. Here are a few quick anecdotes of just how goofy they can be:

- A couple was asleep aboard their berthed boat when they felt someone get aboard and start to slide open the companionway. The husband leaped out of bed, grabbed a shotgun, cocked it and prepared to deal with the intruder. But as soon as the intruder realized there were people aboard (it's amazing what a motivator it is to hear a gun cocking and realize it's for you), he took off running.

The husband burst out of the boat in hot pursuit, chasing the intruder all the way up the dock, up the gangway, and out the gate. Only when it slammed behind him did he realize that he was standing there, with a cocked shotgun in his hands, stark naked — and without a gate key. Imagine being on duty at the harbor office when *he* came knocking at the door.

- One day a man dressed all in black came into the harbor master's office of a marina in San Francisco and, in a thick accent, asked for political asylum. The harbor master said, "We don't handle that here," and sent him to Customs.

- The harbor master who arrived at work in the morning to find one of the tenants in a bit of a fix. He had a bit too much to drink the previous night and had somehow managed to haul himself to the top of his mast and gotten stuck there. He was also naked.

- A young Japanese couple was enjoying a day at Pier 39. In the afternoon,

they wandered from the touristy center of the Pier to the outside to admire the boats. At some point, the woman accidentally

dropped in the water a teddy bear that her boyfriend had won for her. Without thinking, the man jumped over the railing into the water to save the stuffed bear — and couldn't get out. Despite the language barrier — neither of them spoke English — Pier 39 personnel managed to rescue both man and teddy. The man's clothes shared the marina's dryer and everyone lived happily ever after.

- An older couple arrived at their boat one Saturday morning to go for a sail — only to find the hatches open and music coming from down below. They called out for anyone aboard, and a clean-cut young fellow came up, coffee in hand and said, "Can I help you?" The man said, "Yeah, this is my boat." The 'stowaway' barely batted an eye. He said, "Oh, you're here! Just one second." Then he went below, turned off the music, stuffed a few things in a duffel bag and hopped off onto the dock. "Have a great day out there!" he said. Upon inspection, the couple found that nothing was missing, and in fact the young fellow had obviously done a fastidious cleaning job! They admitted later that he was so nice they almost didn't report the incident.

- It's not always the boaters who are the source of entertainment for harbor masters and their crews. One time when one of the marina crew was doing some demolition work on an old dock in the City, he cut the end off a dock with a chainsaw — and then realized he was on the part that was no longer attached to anything. Of course it happened in front of God and everybody — including the rest of the crew, many tenants and the harbor master, who had to tow the guy in before he drifted out to sea.

- A strange spectacle that's played itself out time and again at many marinas involves people getting pulled into the water by docklines. These are almost always folks new to boating. Wanting to

be helpful, they'll untie a bowline, then walk down a finger as the boat pulls out, still holding onto the line. They let the line slide through their hands, but when it gets to the end, instead of letting go, they hang on — and get jerked into the water. "We still don't know why anyone would do that," said one harbor master. "But we see it all the time."

Not all 'live ones' are people. Every harbor master of long standing will have at least one heartwarming story of some interaction between local wildlife and boaters. Perhaps it's a mother duck and her flock who adopted a certain boat. Or a seagull who befriended a liveboard dog — those two would actually eat from the same bowl and sleep together in the cockpit. In the case of Pier 39, of course, most of the 'wildlife' stories revolve around a loud and rowdy group of tenants: the Pier's popular sea lions.

"Sea lions are incredibly smart," says longtime harbor master Sheila Chandor. "And they have a great sense of humor."

"If one of our guys is down working on the docks, you'll often see a sea lion slip into the water, swim around the dock and then come up and splash him with its flipper. Some of the younger ones will actually swim under the dock, come right up in the worker's face and do this little bark that I think is the sea lion equivalent of 'boo!' It can really be a shock if you're not expecting it!"

The sea lions at Pier 39 have their own specially-built docks on the western side of the Pier. That's also where many of the guest slips are, so it's a constant challenge to keep the big pinnipeds on their docks and off the boat docks — and boats. In the old days, the pier crew used all manner of popguns and firehoses to scoot them away. But a few years ago, some bright person noticed that the thing basking sea lions hated most was ... getting wet! So these days, Pier 39 uses portable rainbirds attached to motion detectors to keep sea lions off the boat docks. These work very well — except when the harbor crew forgets to turn them off when a guest boater arrives. More than one visitor has arrived at the main office to get his temporary gate key . . . sopping wet. Oops.

Finally, there is the tale of Ollie, the fender-stealing sea otter of Pier 39.

Ollie appeared at the popular tourist



Ollie the otter. So that's where all the fenders have been going.

SHEILA CHANDOR/PIER 39

OF HARBORMASTERS

BUT SERIOUSLY, FOLKS

With the present state of the economy, many harbormasters are currently faced with a new problem: folks who can't pay their berth rents. One longtime harbormaster noted that he used to get two to three bounced checks a year. Recently, he got four in just one month. Even more unfortunately, this means more lien sales of boats whose owners can't make their monthly berth payments.

If you find yourself in this situation, all the harbormasters we asked said the same thing: just give them a call and talk about it. Don't expect them to lower your monthly rate, but many, if not most, will be happy to negotiate, perhaps spreading the payments out over the month or letting you slide a week or two longer.

destination back in the summer of 2007. Residents first noticed him playing with a boat fender. Sure, it was cute, but it wasn't long before Sheila and her crew figured out that he'd pilfered the fender from a parked boat. They got it back when he wasn't looking, but the next day, he showed up with another. And so it went.

Ollie eventually ended up with one particular fender that he really liked. He spent endless hours playing with it. One time when the crew tried to get it away from him, Ollie locked one little paw around the fender and the other around a boat rudder. Eventually, the shop crew made him a toy out of two little fenders

and the rash of fender burglaries came to an end.

Like the sea lions, otters are wild animals. And despite their proximity to hundreds of tourists every day, wildlife experts discourage close encounters and feeding. That's why tourists aren't allowed on the sea lion docks, and that's the main reason that Sheila eventually called the Monterey Bay Aquarium, whose tag Ollie wore on one of his webbed feet. She felt Ollie was just way too friendly with people and she was afraid something might happen to him. Turns out the Aquarium had rescued him as a pup. When he had reached maturity some weeks earlier, they'd let him go in Mon-

terey Bay. He'd made quite a swim to arrive in San Francisco.

We should say he was friendly to his *new* friends. As soon as the MBA 'relocation team' showed up, Ollie took one look and dove into the water. Nobody could get near him all day. It was almost as though he recognized his old captors and wasn't going to let them take him back to The Big House. The Aquarium folks tried the better part of the day to get him, but it just wasn't happening. Finally, Sheila asked if her crew could try something. Sure, said the Aquarium guys.

So they got the little fender toy out and waved it at the end of the dock. Ollie practically shot out of the water and right into the arms of his captors.

"We knew we were doing him a favor, but it still felt bad to trick him like that," she recalls. "And he was furious! We could hear him screaming and hissing the whole way to the truck."

At last word, Ollie had been re-released a little farther down the coast, hopefully there to find a more suitable playmate of the female persuasion.

— latitude/jr

BERKELEY MARINA



Centrally located off Hwy. 80 at University Ave. • Fast Access to the Central Bay • Fuel Dock • Marine Center with 35 Ton Lift Capacity • Launch Ramp • Waterfront Hotel • Restaurants • Adventure Playground • 17 Acre Off-leash Dog Park • Picnic Sites • Deli and More...



CITY OF BERKELEY
PARKS RECREATION AND WATERFRONT

Berkeley Marina Office

201 University Ave. • 510-981-6740

Visit our website at: www.ci.berkeley.ca.us/marina

THE REINCARNATION

If you've been sailing the Bay for a while, you may remember *Isobar*. This pretty 45-ft sloop was designed by Les and Don Harlander for their own use. Her sleek lines drew inspiration from several Sparkman & Stephens racing yachts of the '50s and early '60s, most notably *Finisterre*. *Isobar* was built at the Cheoy Lee shipyard in Hong Kong and launched in 1962. The Harlanders raced two Trans-Pacs with the boat, in 1963 and 1965, finishing mid-fleet both times.

But *Isobar's* best known owner was Richard Steinke, a mechanical engineer who worked for both Chevron and Shell Oil as an engine lubrication expert. Steinke acquired the boat from the Harlander brothers in 1971 and she was rarely idle after that. When work took him to England in the mid-'70s, he sailed there in *Isobar*, and later sailed her all over the Med. He returned to the Bay in 1984 and for the next eight years left no local sailing stone unturned. Our first article by Richard detailed his extensive cruising of the 'forgotten coast' north of San Francisco. Many more articles by and about him and *Isobar* followed.

After he retired, Steinke sailed *Isobar* out the Golden Gate in the early '90s, intent on a circumnavigation. He was in the homestretch when he passed away in the Philippines in 2003 at age 70. We heard rumors that ownership of *Isobar* had passed to a family member in Seattle, but soon lost track of the boat. So we were overjoyed when we received word that she was not only back in the States, but back in the family, and in better shape than ever. Here's how she got there.

When Richard Steinke passed away five years ago, ownership of *Isobar* passed to his stepdaughter — my wife — Jessica. Richard had raised Jessica since she was 4 and the two of them were very close. The boat had also been a big part of our lives; we had spent several vacations sailing aboard *Isobar*, including our honeymoon spent visiting Russia in 1993.

But despite romantic dreams of bringing her back to the Northwest, the reality was that *Isobar* was totally beat up, and we really couldn't afford to both ship her home and fix her. We put a delivery crew aboard and sent her on her way back to Phuket, Thailand, where Richard had lived and raced for a few years before beginning the trip home. We felt the boat would be well known and likely to sell there. Enroute, the news that she was for sale reached Des Kearns, a marine surveyor and boat

was the perfect person to own her, and agreed to sell.

Des spent a large amount of time, money, and love (yes, love — no one buys an antique wooden sailboat as a prudent financial move) fixing her up, and repairing all the details that Richard had let go as his health failed. During the process, the boat endured further insult when she was caught and damaged in the Boxing Day Tsunami in December 2004. After that, Des had to effect even more repairs. Once the boat was fixed up, Des continued Richard's tradition of competing — and very often winning — in local regattas like the King's Cup.

Life being what it is, Des ran into ***Under Richard Steinke and later Des Kearns, 'Isobar' racked up an enviable racing record in Far East sailing events.***

On January 7, 'Isobar' was moved back into the water.

restorer based in Malaysia. He knew the boat from Phuket and made us an offer essentially sight unseen. We felt that Des

his own health issues and the related lifestyle changes prompted him to put *Isobar* up for sale again in December



2005. Now that she was repaired, and after a long series of serendipitous events (a grand story for another day), we decided to buy her back.

Isobar arrived in Seattle via freighter on November 9, 2006. While waiting to be unloaded the next morning, she was struck on the bow roller by a container being unloaded forward of her in windy and rainy conditions. We originally thought the damage was minimal — a bent bow roller and torn-up bulwark





A covering board had been added circa 1994 to make this joint more waterproof, but in all likelihood, this eventually contributed to the rot by trapping moisture and concealing the problem from subsequent surveys and Des' restorative efforts.

At this point the repair estimates soared beyond reason, the surveyors fought, the insurance companies balked, and we even considered selling her for scrap and walking away.

We're still not completely sure what happened, but Jessica and I arrived at a place where we decided that our vision for our lives included this boat. So in March of 2007, we gave the go-ahead for an exhaustive schedule of repairs. A key element in our favor was that Don Harlander, one of the pair of brothers who designed *Isobar*, now lived nearby on Vashon Island and could provide original drawings and first-hand knowledge of her design. Reason be damned!

What followed was a long, agonizing process of legal fights with surveyors and insurance companies, making hard design trade-offs, and soul-searching around the wisdom of spending such large amounts of money on an old wooden boat.

Isobar had been remarkably well built originally — and rebuilt under Richard's ownership. Her hull was edge-glued Philippine mahogany with a teak-over-plywood deck, built 'monocoque' style: with bulkheads but no frames. After taking a terrible pasting in the

Moving day — After two years of restoration work in a shed at the Seaview East Boatyard in Seattle, 'Isobar' heads back to the water in early January. Inset, current owners Rob and Jessica Hickey.

— but in the course of investigating what it would take to fix this damage we discovered that there was more. The wheelhouse had been loosened by the impact transmitted through the lashings, and there were now numerous and significant cabin leaks as she sat on the hard after unloading.

In January, 2007, we moved her to the

large blue barn at Seaview East Boatyard to get her out of the weather and evaluate the necessary repairs. Soon thereafter

came the news that the boatyard had found some rotten wood near the bow roller. And some more rotten wood a little farther aft. And yet more aft of that. Basically, the joint between the hull and the deck had rotted around the entire periphery of the boat.

Atlantic en route to Ireland (during which the boat was dismantled), Richard paid an English yard \$45,000 — more than she

was worth at the time — to fix the damage and retrofit frames. When completed, she was tremendously strong, and proved it when Richard

cruised her all up and down the English Coast . . . in the winter.

But that had been 30 years before and

Did I mention there was sanding and painting involved?

THE REINCARNATION

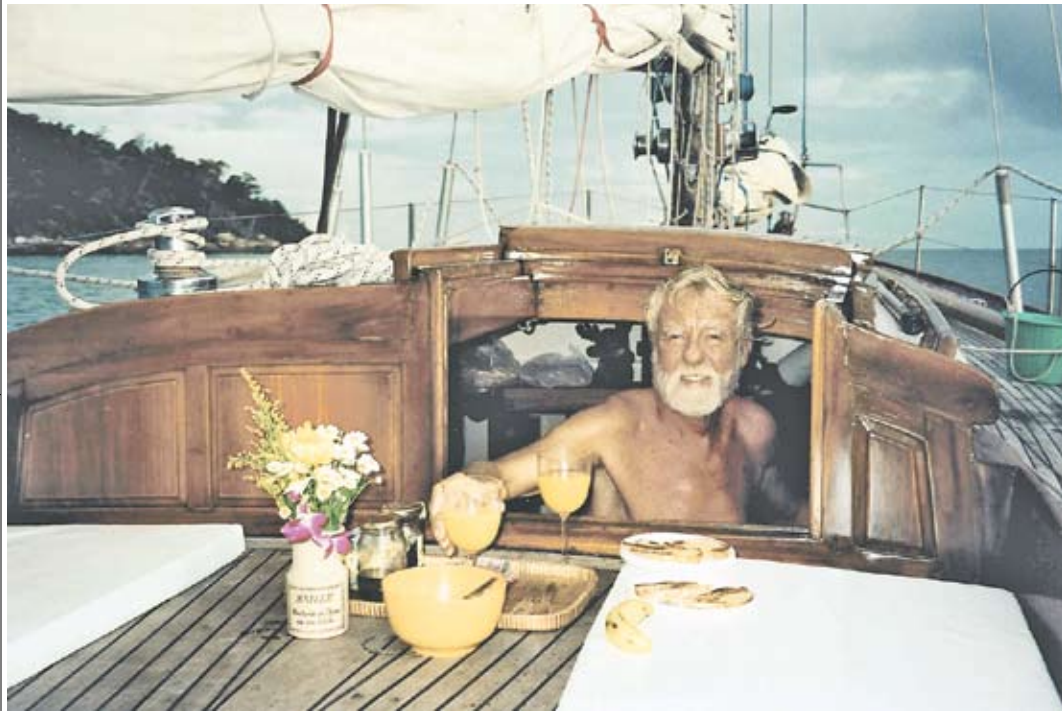

time takes its toll. The work began.

Old parts were cut out, torn or pried off, or sometimes just fell apart of their own accord. New parts were cut, planed, welded, laid-up, bent, drilled, wired, screwed, plugged, glued, and sealed. Things were sanded and painted, then sanded and painted, and then sanded and painted yet again. Estimated completion dates came and went. More broken, rusted, and obsolete things were found. Some were replaced, some were repaired, some were eliminated. We kept writing checks, and did some

From the 'Isobar' scrapbook (this page, clockwise from above right) — 'Isobar' gets loaded on a containership for the ride back to Seattle; on the 'operating table' for her extreme makeover; rot in the hull-deck joint began in the bow and extended all the way aft; the shipping damage that started the rebuild process; "Can I freshen that cocktail for you?" Richard Steinke was an unforgettable character to all who met him.

sanding and painting ourselves. Did I mention there was sanding and painting involved?

Slowly, we came to a point where the remaining repair jobs didn't need to be completed under cover, so I could not be more pleased to tell you that on

January 7, *Isobar* was moved from the barn, where she's been under repair/reconstruction for the last two years, back into the water. She needed to stay in the slings for a few days while her hull got used to the idea of being wet again. But it was a great feeling to see the boat back in her element.

She's now tied to a dock at the boat-



yard. The mast has been resteped, but there are still several more weeks of rigging, tuning and outfitting ahead before she'll be ready for the open water. Hopefully that's plenty of time to let the people whose lives have been directly and indirectly associated with this boat know that we've reached a major milestone in the process of bringing *Isobar* back to life. Ultimately we will berth her at Shilshole Marina and look forward to seeing many of her friends there in the

Left, 'Isobar's interior is as functional as it is pretty and comfortable. Center, Des Kearns. Right, the transom is pretty far gone, but Rob and Jessica are happy to have saved and remounted it.

future.

Many people have asked about the restoration. While we were adamant about maintaining her overall look and character, those of you who have spent

time on her may have noticed a few changes. Among them:

- The entire deck, top 8-10 courses of the hull bulwarks, and the caprail are all new. The caprail is a beefier cross-section than the original, but rides the bulwark tumble at the bow and stern better. All deck nib joints and the caprail scarfs are true to the original design.

- We elected to chrome the hawse pipes instead of painting them. Bronze doesn't really like paint, and they match



Dispense Six10 Thickened Epoxy Adhesive from any standard caulk gun.

Epoxy. Effortlessly.

Six10™ Thickened Epoxy Adhesive: the permanent, waterproof, gap filling and bonding performance you expect from WEST SYSTEM, in a self-metering cartridge. The static mixing wand automatically blends the resin and hardener. All you need to do is squeeze.

**WEST
SYSTEM**
BRAND®

Perfect epoxy
for an
imperfect world



866-937-8797
www.westsystem.com

THE REINCARNATION

the other hardware better.

- The covering board was not replaced. It was a stopgap addition, we really didn't like the look, and it interfered with deck drainage. To improve waterproofing, we elected to add fiberglass between the teak deck and plywood subdeck, as well as in the hull-deck joint.

- The main salon skylight has been raised and hinged. The original built-in skylight was a constant leakage threat, and this arrangement is more water-proof. This gives us another ventilation option. The old liferaft used to live on top of this skylight, so we'll have to find a different spot for that. The small skylight over the head was added by Des, and we liked it so much we kept it.

- The cockpit portlights are new. The older port/starboard stained glass portlights were leaky and in serious disrepair. We also felt they were slightly dated (read "70s"), and we elected to go stainless for the trim to match the wheelhouse portlights and the clean look of the other hardware.

- The coaming between the forward edge of the house and the forward hatch



'Isobar' back in the early days. The boat is every bit as sound and pretty now as she was 40+ years ago.

has been removed. While it occasionally provided a handhold in rough seas and a

convenient place to lash extra water and fuel, mostly we found it to be a toe-stubber. The original coaming was also beat to crap, and we really liked the look of the open space around the mast step.

- The dorades at the mast step and the funnel at the bow have been removed. These may go back depending on ventilation needs, but we're trying to minimize the number of deck penetrations.

- The anchor windlass and bow roller will eventually go back, but haven't been refurbished yet. Almost a shame to break up that clean bow look, though. Not sure we'll replace the stern roller for a second anchor.

- The number of winches has been significantly reduced. We have restored the rigging to the original two-winch configuration, and will reevaluate as we move through the full re-rigging process. The bolts attaching the winches and cockpit cleats to the cockpit coaming have been replaced with stainless backing plates — no more poking your toes and back on bolt heads.

McDERMOTT COSTA

insurance brokers - est. 1938

Commercial Operations

- COMMERCIAL POLICIES
Marinas, Yards, Yacht Clubs, Brokers, Shipwrights

Pleasure Yachting

- YACHT & BOAT POLICIES
Offshore, Coastal, Inland and Liveaboards



Lic. #OB21939

Bill Fowler
McDERMOTT COSTA INSURANCE
(925) 606-6606 Fax (510) 357-3230
bfowler@mcdermottcosta.com



ELLIOTT / PATTISON SAILMAKERS

Ragtime

1st IRC-2 Sydney Hobart Race



PHOTO: DAVID BRAY YACHTS

For information:
949 645-6697

LA Harbor Area:
Steve Dair 310 619-7245

Marina Del Rey:
Doug Johnstone
310 528-2146

Oceanside: Lee Pryor
760 529-0062

We have a passion for building sails. Call us about your next set.

870 Production Place
(949) 645-6697
Newport Beach, CA 92663



ALL PHOTOS COURTESY ROB AND JESSICA HICKEY

- The cove striping has been restored to the "arrow" motif of the original plans.
- The 'ISOBAR' carved near the bow

'Isobar' has taught us much about endurance and renewal.

was not reproduced. Though to many — myself included — this was a definitive characteristic of the boat, it was a later addition and was roughly done. We eventually came to the decision that it made the bow look a bit crowded. We can always add it back in later if we decide we really miss it.

We were very fortunate to be able to save the original carved transom, and the nameplate carving will eventually be painted gold to match the cove stripe. Of course we're keeping "San Francisco" as the hailing port. We wouldn't dream of

changing that!

There were often days when we didn't think we'd get to this point. There are many people to thank for seeing us through, from the patient ones who put up with our constant mutterings about rotten planking, corroded thru-hulls, schedule delays and cost overruns to the fine craftsmen of Sea View Boatyard. We also owe a serious debt of thanks to Des Kearns for all his previous work and care. And an extra special thanks goes to Don Harlander, not only for his design expertise, the original *Isobar* plans and drawings and guidance he provided during the project — but also for his unfaltering support of our efforts.

We certainly owe Richard for what he showed us, in his own indomitable style,



'Isobar' looking pretty in Phuket. In her new incarnation, the number of winches has been radically reduced.

about what was possible in life. We trust that his spirit is at peace now that *Isobar* has returned to the water. Lastly, we are deeply indebted to *Isobar* herself, who has taught us more about endurance and renewal than we ever could have learned on our own. She is beautiful and fearless. She is mended and whole, and now waits impatiently to taste the wind.

— rob and jessica hickey



BoatU.S. Member Bruce Fournier aboard "G'Day" on the Braden River in Florida.

With BoatU.S. Insurance, You're Not Just A Number...

"So often in this day and age, customer service representatives are indifferent in their dealings with clients over the phone. I was extremely satisfied with the helpful and courteous way my insurance inquiry was handled and want to thank you for having people of this caliber available for your insurance customers."

—Bruce Fournier, Bradenton, FL

You're Number One!

At BoatU.S., you'll find boating experts with the answers you need when you call. Our knowledgeable Underwriters not only find the perfect coverage for your boat and boating lifestyle, we'll work with you to help find ways to save on your premium. And, as a Berkshire Hathaway company, you can be sure BoatU.S. will be here each and every time you need us.



For a fast, free quote call

1-800-283-2883

priority code 4848

or apply online at **BoatUS.com**

All policies subject to limits and exclusions.

MAX EBB

The morning sun was so warm it was easy to believe that winter was over, even though it was still February.

I'd arrived at the boat early, and opened up all the hatches and lockers to give things a good airing out. I wasn't up for singlehanding on a day with a gusty northeast wind forecast. It would, however, be an excellent day to recruit and train some new race crew, if I could find any prospects at short notice.

The best crew resource by far is a college sailing club, and my marina is fortunate to have one. True, sometimes their less-experienced skippers crash into the boats on end-ties, but that's just part of having an end-tie.

Leaving my boat open to the air and sun, I walked around the harbor to the sailing club's little shack of a clubhouse, where I found a young woman with a clipboard.

"Any crew here that want to go sailing?" I asked.

"Name?" she demanded.

I answered, although it seemed like an unnecessary formality to write down my name when all I wanted was some pick-up crew.

She flipped to another page on the clipboard, and read off two more names. A young athletic-looking man and a somewhat older but attractive woman appeared.

The clipboard-holder reminded them to pick up PFDs and then sent them down the gangway to the dock, where a modern-looking sailing dinghy was riding to its bow painter, sails luffing lazily in the lulls between the warm gusts of land breeze.

"Anyone want to go out for some crew training?" I asked again.

The woman looked at me as if I was really dense.

"I just sent them down to the dock," she said. "They're ready to go."

Why would she send them down to the

dock if they're coming sailing with me? And how did she know what they wanted to do? No matter, I followed them down to the dock, and since they were already sitting in the dinghy's cockpit, I climbed in after them.

"Are you two interested in learning how to crew on a race boat this morning?" I asked.

"That's what I'm here for," said the man.

"I just want to learn to sail," added the woman.

"Great!" I said. "If you would like to come out on my boat, it's just around on the other side of the harbor. It's a perfect day to learn how to trim a spinn . . ."

That's when I noticed we were moving! Someone on the dock had cast us off, probably thinking they were being helpful.

"What do I do?!" shouted the woman, who was closest to the tiller.

"Grab that stick and hold it in the middle of the boat," I directed. "Now move it this way," I said, gesturing in the direction that caused the boat to fall off to the tack that would take us clear of the next row of boat berths.

Having regained some control of our backwards drift, I had a couple of seconds to find the mainsheet and move to the windward side of the cockpit. As we bore away, the sail filled, I sheeted in, told the woman at the helm to return the tiller to centerline, and we were off.

"Is this your first time sailing?" I asked.

"Yes!" There was panic in her voice.

"What about you?" I asked the male crew.

"It's my third lesson. But I've also crewed in some dinghy races."

"Good, you can explain to her how the tiller works while I figure out the jib sheets on this boat."

The guy was good with words, and

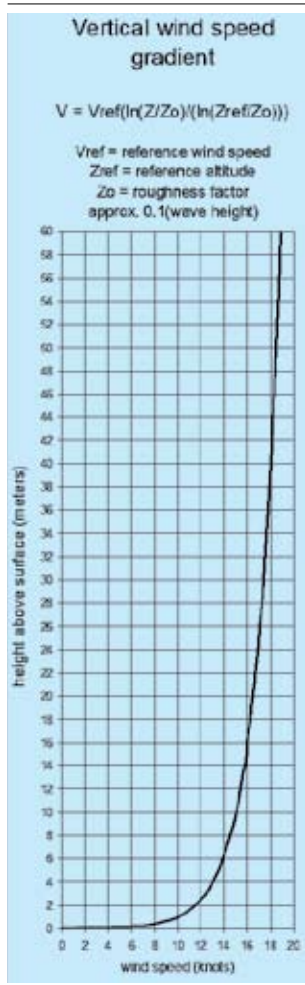

Wind velocity profile as a function of height above the water. This curve is for a 15 knot breeze at 10 meters above 0.1 meter waves. The actual velocity profile depends on wave height, wave roughness (whitecaps vs. swells) and the vertical stability of the air mass.



Experienced sailors and newbies alike expect to get wet sailing small boats on the Bay.

had our new student steering a straight reach to a landmark on the other side of the harbor before I had sorted out the fancy cross-sheeted loop of jibsheets. Eventually I had the jib trimmed, and the boat was finally sailing at full power.

It was a very nice machine. More lively than the usual basic sail trainer, but big enough to hold all of us without being too cramped or sluggish.

"Don't worry about the sails or anything," I suggested. "Just get the feel of steering with a tiller."

She was a natural. I find that about one out of three people have no problem steering with a tiller on their first try, and she was the one out of three, despite being visibly terrified by the whole



PETER LYONS / WWW.LYONSIMAGING.COM

process.

"What were you saying about your big race boat on the other side of the harbor?" asked the other student.

"That's why I came over to the sailing club," I explained. "I was just looking for crew. For some reason they cast us off. I'm not even a member here."

A new wave of terror swept over the woman driving, and she clutched my arm.

"You mean you're not a real instructor?" she trembled.

"It's okay, I know how to sail this thing, I think. But don't let go of the tiller!"

The jib was already starting to backwind, but fortunately we had enough

momentum to recover after I pulled the tiller back up to windward.

"First rule for when you panic," I said, "Is to keep control of the tiller. Steering the boat is priority Number One. Priority two is keeping your weight on the high side — if we had turned any more, the jib would have backwinded and forced us to tack. The wind would've been coming from the other side of the boat and we would've gone right over."

"Right, always steer," she said through clenched teeth as I gave the tiller back to her and she loosened her grip on my arm slightly.

We sailed for a few more minutes like this, out past the breakwater and into increasing wind. With every new

gust she would slide closer to me and grab my arm, my knee or my shoulder, and I can't say it was unpleasant to have an attractive woman a good deal younger than me making those moves, whether fear-induced or otherwise.

Suddenly there was a small powerboat bearing down on us from astern at high speed.

"They're overtaking," I said. "We have right-of-way so just hold a straight course."

But the Whaler kept coming right at us, full speed.

"Uh, I think I'd better take it," I said as I cleated off the jib sheet and unfolded the hiking stick so I could steer from my position forward of the helm. The woman grabbed me as if we were both starring in a grade B horror movie and

MAX EBB

the monster had us cornered. Kind of fun, but I really was starting to worry about this powerboat aimed right at us. I turned downwind, it turned with us, and at the last second it powered down and dropped off plane, pulling up even with our windward side after matching our speed.

"Max! What are you doing in that boat? You're not rated to be an instructor."

It was Lee Helm, a naval architecture student and active member of the sailing club. She must have seen my name on the clipboard, which I now realized was the sign-up sheet for sailing instructors.

"No kidding!" I hailed back over the engine noise. "This wasn't my idea."

"And you don't even have a PFD!" she moaned. "If you were, like, a club member we'd suspend your sailing privileges for this. But you don't even *have* any sailing privileges!"

The powerboat driver made a gesture which I understood to mean "let out your sheets," which we did, and both boats slowed down enough for the Whaler to come alongside. Lee hopped in, bringing

an extra lifejacket with her. The powerboat sped away.

"Okay, now at least we're, like, legal," she said after I'd put on the PFD.

I explained how the mix-up had happened. But it was a perfect sailing day with a fresh warm breeze off the land, and we didn't see any reason to end the lesson. I slid forward, the woman student moved to the leeward side, and Lee put the male student on the helm.

"Let's go close-hauled and do a couple of tacks to warm up," she began.

The student took control of the main-sheet and sheeted in as he turned the boat into the wind. Lee took the jib sheet, and she and the other woman hiked out on the high side while I sat to leeward.

He had a lot more confidence at the helm, but his steering wasn't nearly as good despite the lesson time he'd already logged.

"For sailing close-hauled," Lee ex-

plained calmly as we attempted to shift our weight to keep up with his luffing and filling, "you have to steer more precisely. Keep an eye on a landmark. Every degree of course change up or down totally makes a difference in the heeling force."

The close-hauled sailing was taking us into more open water, and the gusts were freshening. The boat was fast and there was just enough chop to send some spray over the rail. Lee and the student could stay dry, but the front of the boat was getting wet.

"Now for some tacks," directed Lee.

The first one was a serious overshoot on the course change, and we nearly capsized right there. The tacks got a little better with repetition, then Lee finally noticed we were making heavy weather of it up forward, and had the student bear off to a reach to look at sail trim.

"See how the sail luffs first on top and last near the bottom?" Lee said as she had the student make the sail luff and fill, first by sheet adjustment and then by course changes. "That's a result of twist

Measure Your Savings!



Measure your boat and save on North Sails. Visit northsailsdirect.net or call 888-424-7328.

NORTH SAILS
direct
formerly Cruising Direct



FREE 100 ft.
North Sails Direct
tape measure
with your order!

Boat size restrictions apply.
Offer valid while supplies last.

GLEN COVE MARINA



- Covered Slips Available
- Home of the Glen Cove YC
- 135' Guest Dock
- Free Wireless Internet
- Waterfront Cafe
- Showers & Laundry
- Free Pump Out
- On-Site Security
- Yacht Broker
- Storage Units Available

GLEN COVE MARINA 707-552-3236

2000 Glen Cove Road, Vallejo, CA 94591

www.glencomarina.net • glencomarina@gmail.com

TWISTED LOGIC

in the sail. The angle of the sail's section is different at the top from at the bottom, relative to the boat's centerline."

"More boom vang can reduce the twist, right?"

"Yes, exactly. But in a small boat you never want to completely eliminate twist, because the wind hits the sail at a different angle near the top."

Lee tightened the boom vang to remove most of the twist from the mainsail. Now the main luffed first at the bottom half while the top stayed full whenever we changed course to windward.

"I know why this is happening," said the student. "The wind aloft is deflected a little to the right compared to the surface wind. So on starboard tack we need twist like we have now. But on port tack, it should be reversed, with the top of the sail trimmed closer to centerline than the bottom."

I noticed that he was sliding forward on the seat as he spoke, pressing up a little closer to Lee, pretending to study

the twist in the sail as he moved.

"Good theory, but it's wrong," said Lee as she slid forward an equal distance to

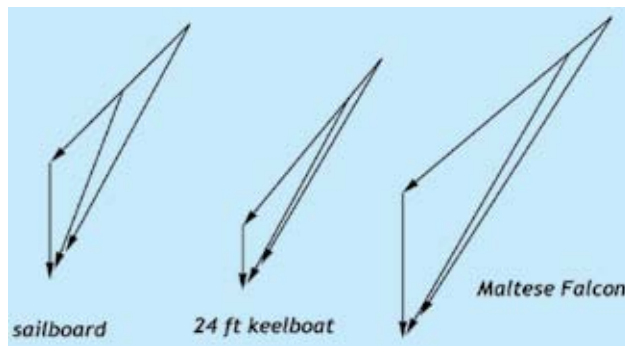

Apparent wind speed and angle at the top and bottom is different for different boat types. The windsurfer, with the bottom of the rig very close to the surface, needs to trim for the largest amount of twist.

keep clear of his advance.

"The wind direction is twisted because of the velocity gradient," explained Lee.

"Not because of the surface friction on the geostrophic wind or the Ekman spiral."

"No way," he responded. "Velocity gradient doesn't change the wind angle."

We've been studying wind flow in my environmental engineering class, and the change in wind direction with altitude is very consistent at mid-latitudes."

"Insignificant at this scale," Lee asserted.

"I don't think so," he insisted.

"Okay, let's do an experiment," Lee proposed. "Come about, and check the twist on the other tack. If the true wind direction is twisted, we'll find reverse twist on port."

We flopped over onto port tack one more time, and they did the same exercise with the sail trim. The result was the same — the sail luffed evenly, top to bottom when it was trimmed with a fair amount of twist, and luffed last on top when the twist was reduced. Of course, Lee was controlling the jib sheet so she could dial in any amount of twist in

"The elegantly simple, single-sail Wyliecat 30 makes the fun of sailing instantly accessible."
Sailing Magazine

Experience the high performance and simplicity of the Wyliecat design.

WYLIECAT 30
Sailing in The Right Direction

Models: 17 | 30 | 39 | 48 | 65 | 66

www.wyliecat.com • Tel: 916-743-7194

The Difference? Superior Engineering

- NO moving parts
None
- NO maintenance
Ever
- LIFETIME warranty
As long as you own it

SPIN-TEC

If you are considering a new roller furling system, you owe it to yourself to learn more about the Spin-Tec Triumph Series.

1.877.774.6832 | SPIN-TEC.com
(1.877.SPINTEC)

MAX EBB

the wind flow hitting the main that she wanted. But the student didn't seem to catch on.

"See?" Lee observed. "The sail is still luffing last on top, proving that the twist on this tack is the reverse of the twist on the other tack. We can also prove that there's no twist in the true wind by luffing up, straight into it."

Lee and the student switched places, and Lee did a carefully aimed luff head to wind.

"Watch the luffing sails carefully. You won't see any change in angle from top to bottom."

The guy was now sliding back on the seat, again pretending to carefully observe the sails while pressing Lee towards the back of the boat.

"One more thing I need to demonstrate," she said as she trimmed the main in hard for close-hauled, then took the jib sheet from me and also trimmed it in and cleated it. We were on starboard tack again, I was on the leeward side, Lee and both students were slightly hiked out to windward, with the guy in the middle still pressing up against Lee, at

the helm.

"Fast tack!" she announced, and without giving anyone a chance to move, she spun the boat around to the other tack.

It went over slowly, but there was nothing we could do to stop it.

... only our PFDs were protecting me from her soaking wet sweater.

Since I had been sitting on the low side before the tack, I found myself on the high side when the mast hit the water, so it wasn't hard to scramble up onto the rail of the boat and stay out of the water. Lee was agile enough to do the same. But the students went swimming.

"That guy needed a little cooling off," Lee whispered. "Sorry to get your lady

friend all wet, but I think she'll, like, relax a little more after she survives a capsized or two."

Lee was experienced with righting these boats, and told me at just the right moment to climb back into the cockpit. I only got wet up to my ankles. Lee was on the centerboard and went in up to her waist, but she was already in her wetsuit in preparation for a day of windsurfing.

"See how important it is to keep your weight on the high side?" I said as I helped pull the drenched students back on the boat.

Lee had the woman student take the helm again, noting that it would help her warm up, while she left the other student in the bow to be a breakwater. She had me sit between the two of them on the high side, while she sat to leeward and controlled the mainsheet for the beginner.

"Here's what's really going on with sail twist," she explained. "It's an apparent wind thing. Draw the vector diagram



OYSTER POINT Marina/Park



A full service marina located in South San Francisco with berthing and guest dockage available

For information and pricing call
(650) 952-0808
www.smharbor.com/oysterpoint



CDI Cruising Design, Inc.

The best value and reliability

- Mainsail and Jib reefing
- The only U.S. patented furling system for Cruising Spinnakers
- Manage all your sails safely from the cockpit!

607.749.4599
www.sailcdi.com
sailcdi@verizon.net

for the true wind, the boat speed, and the wind relative to the boat, which we call the apparent wind. When the wind is stronger, the apparent wind is not deflected as much. Close to the water surface, the true wind speed, like, drops off very quickly. So if you're moving fast, there's a lot of twist to the apparent wind, even though the true wind angle over the water is constant."

"I'll have to think about that," the guy shivered.

"Twist is fairly extreme on windsurfer sails," she continued, "because those sails go down to within inches of the water where the true wind velocity gradient is very steep. There's less twist on bigger boats, and even less on sailing ships, although you can find pictures of square-riggers with the upper yards trimmed for a broader reach than the lower yards."

"I read that *Maltese Falcon's* yards all rotate with the masts," I recalled. "So they can't have any twist in the rig at all."

"That's the monster square-rigged yacht that was sailing in the Bay last

fall," Lee explained for the benefit of the students. "Their rig starts pretty high off the water, so the velocity gradient is not as steep. Still, I think they would trim in some twist if they could."

The woman steering, meanwhile, was back to pressing her thigh up against mine and holding on to my shoulder with her free hand whenever a new gust hit. And I can't say I really minded, even though she was all wet.

But the poor guy in front was shivering even more, so we returned to the sailing club where Lee talked the woman student through a passable docking.

"That was a great lesson, Max!" the woman exclaimed as she gave me a hug, with only our PFDs protecting me from her soaking wet sweater. "Thank you so much. Do you teach here often?"

I had to answer no, but I did remind

them before they ran off to change that I was looking for race crew.

"Are club sailing lessons always like that?" I asked Lee as soon we were back on dry land and the students were out of earshot. "Or is it because Valentine's Day is coming up?"

"Business as usual," she admitted. "Thing is, most of the women here have a rule: They don't go out with older men if their age in years is more than the length of their boat in feet."

"Well, that lets me off," I laughed. "But I would still like to get contact info for those two. Before someone cast us off from the dock, they did seem interested in learning to be big-boat racers."

"No problem, I can get their emails right off the lesson sign-up list."

"Are you sure you don't mind having that guy on the race crew?" I asked. "The way he was hitting on you and all."

"I make allowances," she shrugged. "My hormones can be out of balance for a day or two every month. Guys have to deal with out-of-control hormones every day of their adult lives."

— max ebb



McGinnis Insurance

Since 1972

Knowledge Commitment
Reliability Service



Large and small, we do them all!

Call us at: **800-486-4008**
meginnsins@aol.com

License #0570469

SAL'S

INFLATABLE SERVICES, INC.



Winter Service & Repairs

- EBIRB Testing
- Inflatable Repair
- PFD Parts
- Liferaft Service

It's the season for service. Call today!

USCG APPROVED LIFERAFT FACILITY for USCG/Solas, Yacht and Fisherman Life Rafts. Life raft sales for Avon, Mitsubishi, Fujikura, DBC, Givens, Plastimo, RFD-Revere, Switlik, Viking, Winslow and Zodiac. Inflatable boat sales and warranty repairs for Avon, Achilles and Zodiac. Sales of ACR and McMurdo EPIRBs, signal flares USCG/Solas type and Survival Technologies MOM units.

PHONE (510) 522-1824 FAX (510) 522-1064

1914 Stanford Street, Alameda, CA 94501
salsinflatables@sbcglobal.net • www.salsinflatableservices.com

THE RACING

It might be February, but that doesn't mean there isn't plenty going on around the world of competitive sailing. First off, we take a look at the 2008 **US Sailing Rolex Yachtsman and Yachtswoman of the Year Awards**. Then it's a tip of the hat to **Thomas Coville**; he didn't break Francis Joyon's record, but he came damn close, and never let up. Next up we get an update on some racing closer to home for another installment of **Midwinters Notebook**. What's Boxing Day if not a convenient tag for the day the **Rolex Sydney Hobart Race** start falls on? Then, although it wasn't over before these pages were wrested from our hands, we check in with the progress of the two Bay Area boats at **Acura Key West Race Week** where one was putting on quite the show. Finally, there's a few handy **Race Notes** to finish things off.

Rolex Awards

Add a Rolex to the things that Anna Tunnicliffe and Terry Hutchinson have in common. The winners of US Sailing's 2008 Rolex Yachtswoman and Yachtsman of the year are both former College All-Americans and College Sailors of the Year, and both did their college sailing at Old Dominion University. And last year, they both sailed really well at some big-time regattas.

"I'm very, very excited," said Tunnicliffe, who was the selection panel's unanimous first-ballot selection for the award. "It's a fantastic end to a great year."

For Tunnicliffe, the award capped a year where the 26-year-old won the only U.S. Gold medal at the Beijing Olympics — her first — in the Laser Radial, plus the Delta Lloyd Regatta and Sail Melbourne. She also counted runner-up finishes in the Radial at the Semaine Olympique Francaise and the Snipe Women's World Championship.

And she's not resting on her laurels, having already begun ramping up for a

dream," she said. "Branching out to other boats and expanding myself as a sailor is one of my goals. I want to win another gold medal for the U.S., but I think it will take more than just Laser sailing."

Tunnicliffe was a three-time All-American at Old Dominion and took home the Female College Sailor of the Year award in 2005.

The 40-year-old Hutchinson brought his "A" game to everything he sailed in 2008, beginning the year with wins at Acura Key West Race Week and the Acura Miami Grand Prix as tactician aboard Jim Richardson's Farr 40 *Barking Mad*. But where Hutchinson really shined was across the pond, when in 2008, beginning the year with wins at Audi MedCup just plain dominated the series stacked with America's Cup talent sailing for big-budget programs. Then, a month after the series ended, his team capped it off with a win at the TP 52 Global Championships in the Canary Islands.

"This award is obviously an acknowledgment of a great year on the water," Hutchinson said. "But I would be incredibly remiss if I didn't acknowledge that it is a privilege to represent the bigger picture — the people I sail with and the teams on which I compete. I feel so strongly about the support they gave me; this wasn't just my achievement, it was the *Barking Mad*, *Samba Pa Ti* and *Quantum Racing* teams' too. Every morning I get up and go to work doing something that I love. Being recognized is just icing on the cake."

Hutchinson was twice named the College Sailor of the Year while collecting All-American honors four times at Old Dominion, and he scored his first big professional win in 1992 at the Congressional Cup. He'll return there this March to line up against the world's other top



JACQUES VAPILLON/DPPI/SODEBO

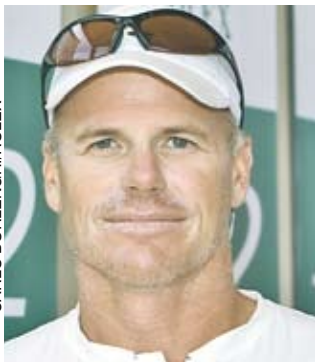

CARLO BORLENGHI/ROLEX



USOC

Terry Hutchinson and Anna Tunnicliffe got the nod for US Sailing's Rolex Yachtsman and Yachtswoman of the Year awards.

shot at another Olympic medal in Weymouth at the London games in 2012. If she's successful, it will essentially mark a return to her roots; she was actually born in England before moving to the U.S. in her teens.

Winning the Olympic medal was a

match racers.

After being shortlisted for the Rolex three times prior, Hutchinson — an Annapolis native — won it in what's been a remarkable year for Americans sailing abroad. His toughest competition? 2006 Rolex winner Nick Scandone, who before he passed away January 2, completely dominated the SKUD 18 class to win a gold medal at the Beijing Paralympics in the waning months of his protracted battle with ALS.

"How could you not be moved by Nick's story when you compare what any of the nominees did this year to the struggle that Nick had in order to achieve the same kind of accomplish-



So Close — Thomas Coville just missed Francis Joyon's Singlehanded 'round the world record.

ments?" Hutchinson asked. "To win a gold medal while going through the battle he had — there are no words that describe Nick's effort and determination."

No Go For Sodeb'O

Becoming the third person to circumnavigate non-stop, singlehanded, in a multihull? Check.

Sailing the fourth fastest lap around the planet? Check.

By any regular sailor's definition, Thomas Coville sailed an absolutely phenomenal passage from Brest and back via the five capes. But by the time he arrived back in his home country

the morning of January 17, the task he set out to achieve — breaking Francis Joyon's record of 57d, 13h, and 31m — had eluded him.

"I gave it my all; I didn't let up for a minute," he said, apologizing for his handshakes — weakened by the wear of what had been a constant uphill battle. "I set out to get the record and that's something I wasn't able to achieve."

The delta between his time and Joyon's — 2d, 7h, and 13m — doesn't quite tell the story of this remarkable voyage.

First, due to the way the weather and ice conditions shook out for Coville, he ended up sailing an extra 1,725 addi-

tional miles compared to Joyon's passage.

Second, at one point Coville was as much as 1,300 miles behind Joyon's time, yet he never gave up. Pushing the 105-ft Irens/Cabaret-designed trimaran *Sodeb'O* at every opportunity, he started grinding back miles as he powered up the South Atlantic, eventually reducing his deficit to just 330 miles in the only area that had slowed Joyon last year.

Then, with the record obviously out of reach, and nearly two months of hard-core sailing behind him, he kept the pedal to the metal all the way into the Brest Channel.

"It's a dangerous and very complicated place to deal with singlehanded," he said of his approach to the finish. "The last night was very special. I was keen to stay under 60 days. I didn't imagine I could stretch myself so far. On shore, you set yourself limits which don't exist."

Transcending those limits is something the 40-year-old proved he can do. And he's proved also that he'll keep on trying as long as that record is there — remember that last year, he was slightly ahead of Joyon's pace having left some two weeks later, when a collision with an unidentified floating object tore off the his starboard ama's crash box, forcing him to retire.

Consider that his average speed was actually slightly higher than Joyon's this time around. Given a little more luck next time, the record could be his. Given what he said on hitting the dock in Brest, we're pretty confident there will be a next time.

"Give me the serenity to accept the things I cannot change, the courage to change the things I can change, and the wisdom to know the difference," he said, quoting what we typically refer to as the 'serenity prayer.' "It's going to take me a while to find the wisdom."

Midwinters Notebook

January 3-4 — While the breeze never really materialized for this weekend's midwinter racing, there was enough to move those who showed up. Add two days of sunshine, and what we got was a great first weekend of 2009. Eight boats in two divisions — the big boats sailing an 8-miler and the smaller boats sailing 6.5 miles — came out for the SBYRA #3 hosted by Oyster Point YC.

On the Cityfront, 52 boats in four PHRF and three one-design divisions came out for the Manuel Fagundes Sea-weed Soup Series at Golden Gate YC.

On Sunday, the Richmond YC Small Boat Midwinters attracted 116 boats in

THE RACING



LATTITUDE/ROB



LATTITUDE/JR



LATTITUDE/ROB



LATTITUDE/ROB

Clockwise from top center — The Berkeley YC midwinters January 11-12: Dueling Olson 30's — Andrew MacFie's 'Hoot' holds a lane with Charles Barry's 'Voodoo Child' threatening; Gary Massari's 'Phantom Mist' gives chase to Henry King's 'Jeannette'; The crew of the Bilafer Family's Henderson 30 'Family Hour' negotiates a jibe; A week earlier at the Golden Gate YC's Manuel Fagundes Seaweed Soup Series Richard Courcier's slippery, Tahoe-based, Farr 36 'Wicked' makes the most of what little air there was; Gordie Nash's modernized Santana 27 'Arcadia'; No wind, no problem!

12 divisions. And over in the Little Harding area, the Sausalito YC Midwinters brought out 31 boats in six divisions, including eight Santana 22s and five

J/105s sailing as one-design classes.
January 11-12 — 'Indian Summer' conditions finally arrived on the scene. The sunny skies and near-record high

temperatures made San Francisco Bay seem more like San Diego — especially with the light, shifty breezes that hit just about every direction on the compass



card.

Of the five midwinter series taking place over the weekend, perhaps the most wind-blessed were those of Berkeley YC and RegattaPro's Winter One Design. While boats sailing the Central Bay often found themselves in drifter conditions, an easterly up to about 10

knots and flat water had boats on BYC's Olympic Circle and RegattaPro's Treasure Island course moving well, at least early in the afternoon. However, soon after RegattaPro's second J/120 start, the wind shifted some 140 degrees and died.

"Usually if the wind dies it's a pretty

good indication that it's going to come back from a completely different direction," noted RegattaPro's Jeff Zarwell. So while another race committee boat eventually finished the 120's at their first weather mark in almost no wind, Zarwell raced around in his RIB looking for any sign of filling breeze. He finally found it

THE RACING

over by Southampton Shoal — not the forecast easterly, but dead out of the west! Jeff and newbie race committee member Ellie Cachette quickly set or reset new marks — including a weather mark that overlapped BYC's leeward mark — and managed to get the whole four-division fleet off on one more race just five minutes before the 3 p.m. deadline. The breeze held steady at 8-10 from 270 the rest of the day. Said Cachette, "I never realized race management was so exciting!"

BYC's Bobbi Tosse also checked in with a report:

"After one says how absolutely fantastic the weather was, what more can be said about Saturday's racing? The wind was a delightful 10 knots or so and stayed reasonably consistent the entire afternoon, the water was flat, the sun was shining, and the racers appeared to know all the rules.

"We sent 61 boats off at the scheduled time to "B" on an 8-mile windward/leeward course and all but one finished. There were no crashes, no blood — nothing gory. Did I mention how nice the weather was?"

"The ties and near-ties left from December have all been broken, but since the series has an even number of races, there could still be ties in a couple of the divisions after February.

"On Sunday, the weather co-operated again and produced wonderful, welcome sunshine. The wind direction and 'oomph' had changed a bit. After a brief postponement, our 35 boats were sent on an 8-mile windward/leeward to buoy "G".

"The story about the cumulative scores is essentially the same as Saturday's. All the first-place ties are now broken and there are still some ties for second. But things are tight enough that anything could happen in February.

As for results, well, you'll find some selected ones in the *Box Scores* located on pages 141-142.

Rolex Sydney Hobart

As the current steward of the Spencer 65 *Ragtime*, Newport Beach's Chris

Welsh added another remarkable passage to the chapter he's helping to write in the iconic yacht's history.

With an elapsed time of 2d, 10h and 38m, the seemingly timeless, teak-fringed black missile took IRC 2 honors in the 2008 Rolex Sydney Hobart Race. *Ragtime* was granted two hours of redress for going to the assistance of the stricken Farr 53 *Georgia*, which had suffered rudder damage and was taking on water.

The Boxing Day race start for the 628-mile, middle-distance classic was greeted with a strong northeasterly that gave the fleet a tremendous jump out of Sydney and down the New South Wales coast. Although the breeze eventually moderated, the conditions were still excellent for a skinny boat like *Rags* and when she crossed the finish line on Tasmania's Derwent River on December 28 — the 18th boat to finish — she claimed the division win as well as 11th overall in the IRC fleet. She was also the first non-Australian and first wooden boat to finish, behind a bevy of recently-built carbon fiber speedsters. On handicap, *Rags* even beat the line honors winner and runner-up, *Wild Oats XI* and *Skandia*, which sailed nearly the entire course within sight of each other until

Chris Welsh has been logging some miles on the venerable 'Ragtime's logbook and collecting some silverware along the way. The boat finished its Pacific tour with a division win in the 628-mile 2008 Rolex Sydney Hobart Race.



CARLO BORENLEIGH/ROLEX



DANIEL FORSTER/ROLEX



LATITUDE/ROB

the former broke away for her record fourth-straight line-honors win under skipper Mark Richards.

Repeat winner Bob Steel and his modified TP 52 *Quest* took overall handicap honors by just under 30 minutes over Alan Whiteley's *Cougar II*. Steel, who's in his 60s, hails from Sydney and in addition to the campaigns he's mounted in IOR 50s, is famous for having thrown his old watch into Hobart's Sullivan's Cove upon receiving his Rolex for his 2002 win in a previous *Quest*. He'd since been on a five-year hiatus from the race, yet still managed to round up five members of his crew from 2002.

Key West Notes

With two races to go, Dan Woolery's brand spankin' new, Pt. Richmond-based *Soozal*, a Mark Mills-designed King 40 was kicking butt and taking documentation numbers in IRC 2 at Acura Key West Race Week as we went to press.

After eight races in which they counted only one finish outside the top three — a fifth — in the 13-boat division, the *Soozal* crew didn't seem too hampered by the fact that Race Week is the boat's first regatta. They had already notched three bullets, one of which came on Wednesday, January 21; that race helped earn Woolery's team 'Boat of the Day' honors.

"This is an extremely competitive fleet and we sailed our butts off today," he was quoted as saying in *Key West News*. "I think the key for us was that we made



California will have three boats representing the U.S. at the JJ Giltinan trophy — the 18-ft skiff class's unofficial world championship — February 12-22, led by two-time winner Howie Hamlin (above).

very few mistakes and we covered up those mistakes by catching the shifts."

It doesn't hurt to have Robbie Haines picking those shifts. Nor does it hurt to have sailors like project manager Scott Easom and Matt Siddens trimming headsails, North Sails' Pete McCormick on main trim, Greg Sultan on the bow, Chris Lewis navigating, Gary Sadamori in the pit and Portland's Deb Hong in the

sewer.

"To win Boat of the Day is quite an honor for the entire crew," he added. *Soozal* had a three-point lead going into Friday's final two races. "We're taking nothing for granted. . . we have to keep the pedal down and keep pushing forward."

Elsewhere in IRC 2, the only other Bay Area boat, Steve Stroub's brand-

new Santa Cruz 37 *Tiburon* is suffering for having the fourth fastest rating while giving up at least three feet of waterline to every boat in the division except a sistership which rates slower than she does. Never intended to race in IRC from the get-go, the design doesn't receive any favors from the rule. This is coupled with the fact that she's a factory replacement to the first SC 37 Stroub took delivery of back in October; no one on the crew had seen this particular boat until two days before the regatta started.

By the time you read this, the regatta will be over; you can check the results at: www.premiere-racing.com/09_KW_Results.

Race Notes

JJ Bound — In what's shaping up to be a first for American skiff sailors, two, and possibly even three U.S. teams will head to Sydney February 12-22 for the **JJ Giltinan** trophy — the unofficial worlds for 18-ft skiff sailing.

The big American name will be Southern California's Howie Hamlin, a two-time winner of the event and former 505 and I-14 world champion. Hamlin will team up with Richmond's Matt Noble — reigning world champion in the I-14 — and Pegasus Racing's Paul Allen of Santa Cruz.

From the Bay Area, the *Skiff Sailing Foundation's* Chad Freitas and Joe Penrod who hail from Alameda will team up with Santa Cruz' Rory Giffen.

THE BOX SCORES

Winer, Wilderness 30, 7. (11 boats)

ULTIMATE 20 — 1) **Salsa**, Matt & Steve Boroughf, 9 points; 2) **Babe**, Phil Kanegsberg/Denise Hammond, 10; 3) **UFO**, Trent Watkins, 13. (9 boats)

MOORE 24 — 1) **Topper II**, Conrad Holbrook, 4 points; 2) **Flying Tiger**, Vaughn Seifers, 5; 3) **Numa Boa**, Mark English, 13. (9 boats)

DIVISION C (132-180) — 1) **Phantom**, J/24, John Gulliford, 6 points; 2) **Froglips**, J/24, Richard Stockdale, 10; 3) **Cheasapeake**, James Fair, 11. (11 boats)

DIVISION D (PHRF >183) — 1) **Can O'Whoopass**, Cal 20, Richard Von Ehrenkrook, 4 points; 2) **Ypso**, Cal 2-27, Tim Stapleton, 5; 3) **Latin Lass**, Catalina 27, Bill Chapman, 10. (7 boats)

SUNDAY 1/11

DIVISION 1 (PHRF to 99) — 1) **Wraith**, Olson 30, Ray Wilson, 4 points; 2) **Corsair**, Olson 30, Don Newman, 11; 3) **Wianno**, J/105 Edward Walker 11. (9 boats)

DIVISION 2 (102-159) — 1) **Dianne**, Express 27, Steven Katzman, 4 points; 2) **1st Impression**, SC 27, Rick Gio, 5; 3) **Twoirrational**, Moore 24,

Anthony Chargin, 11 points. (9 boats)

ULTIMATE 20 — 1) **Salsa**, Matt and Steve Boroughf, 9; 2) **Uagain**, Chuck Allen, 11; 3) **Stella**, Drew Harper, 11. (7 boats)

DIVISION 3 (PHRF >162) — 1) **Froglips**, J/24, Richard Stockdale, 8 points; 2) **Antares**, Larry Telford, 9; 3) **Cheasapeake**, Merit 25, James Fair, 10. (8 boats)

CATALINA 22 — 1) **Brainstorm**, Terry Gobb, 4 points; 2) **Top Cat**, Rachel Hadley, 6; 3) **Dumbo**, David Torrisi, 9. (5 boats)

* Saturday and Sunday races are scored separately. Results were preliminary at presstime. For complete results: www.berkeleyyc.org.

REGATTAPRO WINTER ONE DESIGN (1/12)

EXPRESS 27 — 1) **Motorcycle Irene**, Will Paxton, 13 points; 2) **Magic Bus**, Eric Deeds, 21; 3) **New Wave**, Buzz Blackett, 21. (14 boats)

J/105 — 1) **Wonder**, Tom Kennelly, 16 points; 2) **Blackhawk**, Scooter Simmons, 20; 3) **Wianno**, Edward Walker, 32. (7 boats)

J/120 — 1) **Grace Dances**, Dick Swanson, 19 points; 2) **Dayenu**, Don Payan, 26; 3) **Jolly Mon**, Chris Chamberlin, 26. (6 boats)

J/24 — 1) **Downtown Uproar**, Darren Cum-

Well, since December, Old Man Winter has pretty much been absent. With unseasonably high temperatures and lots of sunny weekend days, January was a great month for sailing on the Bay — as long as you weren't expecting too much breeze. Turnouts have been great for the clubs who began their midwinter series in November, and *much* better for the RegattaPro Winter One Design Series than ever before.

The following results are cumulative unless otherwise noted.

BERKELEY YC MIDWINTERS — SATURDAY 1/10

DIVISION A (PHRF to 78) — 1) **Jeannette**, Frers 40, Henry King, 6 points; 2) **Bodacious**, Farr 40 1/T, John Clauser, 9; 3) **Sand Dollar**, Erich Bauer, Mumm 30, 11. (10 boats)

OLSON 30 — 1) **Wraith**, Ray Wilson, 6 points; 2) **Dragonsong**, Sam McFadden, 9; 3) **Mas Rapido**, Rick Smith, 11. (9 boats)

DIVISION B (81-129) — 1) **Mintaka 4**, Farr 38, Gerry Brown, 5 points; 2) **Shameless**, Schumacher 30, George Ellison, 6; 3) **Extra Action**, Simon

THE RACING

At last word, the third team was not yet decided for the event, which features one race per day at 2 p.m. sharp.

"This will be the biggest ever contingent from the States," Freitas said.

Freitas and other U.S.-based skiffies hope the reverse will be true when the Aussie and European teams visit the Bay for the American Sailing League event at Pier 39, St. Francis YC's 18-ft skiff regatta and Ronstan Bridge-to-Bridge race all in August.

Along with Jeff Causey, Freitas is one of a handful of sailors working on the American Sailing League event, which features short-course racing in a spectator-friendly environment. The current economic climate is making life a little difficult, but they're optimistic.

"Our main goal to keep it going as long as possible," he said. "We've been talking to all manner of people trying to get the word out and sell that product. The nice thing about it is it's a very scalable event — in fact the race course can only accommodate so many boats."

Last year's inaugural event had a lot of positives and we expect to see this year's — there's another the last weekend in May — build on that. In the meantime, you can follow the progress of the U.S. teams as they take on the best from Down Under at: www.18footers.com.au/.

A chance to give back — There's a **US Sailing Race Management Seminar** coming to St Francis YC the weekend of February 28-March 1. It's open to



SHARON GREEN/WWW.ULTIMATESAILING.COM

Dan Woolery's brand new 'Soozal' is tearing up IRC 2 at Acura Key West Race Week as we go to press. Designed by Bay Area expat Mark Mills., the King 40 is showing it's hit a sweet spot in IRC.

anyone, and will be conducted by Tom Farquhar and Bill Gage.

"Most clubs rely 100% on volunteers to run their regattas," said St. Francis YC's Executive Race Publicity Chair Susan Ruhne. "Even the clubs with a professional race manager still rely on volunteers to actually be able to run events! Racers benefit from doing race committee by learning more about the process. Then when racers run races,

they understand what the competitors want!"

You can sign up online at the US Sailing website: www.ussailing.org/racemgt/Race_Officer_Prog/seminars.asp.

You won't want to miss — The **45th Congressional Cup** will be held March 24-28. As the only Grade 1 men's match racing event in the U.S., the classic Long Beach YC regatta always draws a

THE BOX SCORES — contd.

ming, 17 points; 2) **Little Wing**, Luther Strayer, 21; 3) **On Belay**, Don Taylor, 21. (5 boats)

MELGES 24 — 1) **Personal Puff**, Dan Hauserman, 10 points; 2) **Smokin'**, Kevin Clark, 15; 3) **Jam Jam**, Neal Ruxton, 31. (3 boats)

Complete results: www.regattapro.com

RICHMOND YC SMALL BOAT MIDWINTERS (1/4)

THISTLE (3 races) — 1) Michael Gillum, 3 points; 2) Ron Smith, 7; 3) David Rumbaugh, 8. (4 boats)

LIGHTNING (3 races) — 1) Michael Molina, 5 points; 2) Wayne Clough, 5; 3) Ashley Tobin, 10. (5 boats)

EL TORO SR (5 races) — 1) John Pacholski, 13 points; 2) Gordie Nash, 13; 3) Michael Quinn, 14. (14 boats)

EL TORO JR (4 races) — 1) Michael Pacholski, 8 points; 2) MacKenzie Cook, 9; 3) Haydon Stapleton, 12. (13 boats)

OPTIMIST (4 races) — 1) Markus Suorsa, 6 points; 2) Keiran Sweetman, 19; 3) Lucy Wilmot, 20. (11 boats)

SOUTHAMPTON OPEN CLASS (3 races) — 1) Skip McCormack, 5 points; 2) Ted Rogers, 6;

3) Kent Bliven, 7. (9 boats)

BYTE (6 races) — 1) Trish Sudell, 12 points; 2) Michelle Logan, 14; 3) Allison Kidder, 15. (8 boats)

WYLIE WABBIT (3 races) — 1) **Jack**, Melinda Erkelens, 4 points; 2) **Furocious**, Pete Rowland, 9; 3) **Kwazy**, Colin Moore, 11. (8 boats)

29ER (3 races) — 1) Max Fraser/David Liebenberg, 4 points; 2) Finn and Alek Nilsen, 5; 3) Joe Crum/Pat Diola, 11. (5 boats)

LASER (3 races) — 1) Mike Kalin, 4 points; 2) Claire Dennis, 5; 3) James Vernon, 15; 4) Mike Bishop, 17; 5) Drake Jensen, 19. (24 boats)

BREAKWATER OPEN CLASS (6 races) — 1) John Barrere, 12 points; 2) Steve Cameron, 13; 3) Doug Kidder, 19. (12 boats)

FLYING DUTCHMAN (3 races) — 1) Zhenya Kirueschkin-Stepanoff, 3 points; 2) Mike Meszaros, 6; 3) Douglas McWilliams, 11. (4 boats)

Complete results: www.richmondyc.org

GGYC MANUEL FAGUNDES SERIES (1/3)

PHRF 1 (< 69) — 1) **Wicked**, Farr 36, Richard Courcier, 4 points; 2) **TNT**, Tripp 43, Brad Copper,

6; 3) **Quiver**, N/M 36, Jeff McCord, 7. (20 boats)

PHRF 2 (70-109) — 1) **Yucca**, 8 Metre, Hank Easom, 2 points; 2) **Lilith**, WylieCat 39, Tim and Karen Knowles, 3; 3) **Carmelita**, Catalina 42, Chris Lewis, 6. (14 boats)

PHRF 3 (110-126) — 1) **Shaman**, Cal 40, Steve Waterloo, 2 points; 2) **Lazy Lightning**, Tartan 10, Tim McDonald, 3; 3) **Harp**, Catalina 38, Mike Mannix, 6. (7 boats)

PHRF 4 (>127) — 1) **Uno**, WylieCat 30, Steve Wonner, 3 points; 2) **Nancy**, WylieCat 30, Pat Broderick, 4; 3) **Arcadia**, custom Santana 27, Gordie Nash, 5. (15 boats)

CATALINA 34 — 1) **Queimada**, David Sanner, 3 points; 2) **Mottley**, Chris Owen, 8; 3) **Crew's Nest**, Ray Irvine, 4. (8 boats)

KNARR — 1) **Flyer**, Chris Kelly, 3 points; 2) **Knarr 134**, J. Eric Gray, 3; 3) **Narcissus**, John Jenkins, 6. (7 boats)

FOLKBOAT — 1) **Polperro**, Peter Jeal, 2 points; 2) **Thea**, Chris Herrmann, 3; 3) **Nordic Star**, Richard Keldsen, 6. (7 boats)

Complete results: www.ggyc.com



talented field. But this year, the roster reads like a who's-who in top-level sailing — and two of the biggest names aren't even ranked in the world's top 100!

Coming into the event with the 2008 US Sailing Rolex Yachtsman of the Year Award under his belt and a 'lowly' world ranking of 919, Terry Hutchinson will match race for the first time since the 2007 America's Cup, where he served as tactician for *Emirates Team New Zealand*. Interestingly, it will be the first time he's helmed a match race since winning the Congressional Cup in 1992.

Also figuring to be near the top of the field is *BMW Oracle Racing's* James Spithill, who sailed *Luna Rossa* to the 2007 Louis Vuitton Cup final in Valencia.

Brit Ian Williams, winner of the 2007 and 2008 World Match Racing Tours, will be there as will France's Sebastien Col, currently ranked number

one in the world. So if you can get down to Long Beach that week to watch these guys tear into each other for a crimson blazer, by all means check it out. If you can't, follow the action at: www.lbyc.org.

You definitely shouldn't miss — The Latitude 38 Crew List Party is back again this year March 11 from 6-9 p.m at the Golden Gate YC. At a mere \$5 for people under the age of 25 and \$7 for everyone else, it's a low-cost way for motivated skippers to get instant access to motivated crew, and vice versa.

The cost of admission gets you door prizes and plenty of munchies, plus demonstrations and access to guest experts from the Bay's racing scene. Last but certainly not least, those who'd like to partake will find a full, no-host bar serving up some satisfying libations.

You may have noticed that we've moved the party up in the schedule this

year. Why? Because we wanted to give you the chance to get settled with a new program or add new crew to your roster earlier in the year! So come on down. For directions and more info, we've set the party up with a web page all its own: www.latitude38.com/crewlist/Crew.html. If that's not your style, feel free to give us a call at our World Headquarters: (415) 383-8200.

And Finally — Sign-up sheets for the YRA season appear on the following two pages of this magazine. This is the last time they'll appear in our fine publication this year.

If you decide to register at a later date and/or don't want to deface your archive copy, you have a few options: 1) Go to www.yra.org; 2) Pick up a copy of the *2009 Northern California Sailing Calendar and YRA Master Schedule*; 3) Download and print 'em from: www.latitude38.com/YRASchedule/YRAindex.html; or, 4) Call the YRA office at (415) 771-9500.

Now there . . . you have one less excuse *not* to Get Out the Boat this year.

COAST MARINE

& INDUSTRIAL SUPPLY INC.

398 Jefferson St. San Francisco - On the Wharf.

Call **Bruce Becker** or **Clark Atkinson**
(415) 673-1923 (415) 516-4860

800-433-8050
Fax (415) 673-1927



LIFE RAFT

Sales & Service

U.S.C.G. Approved Testing Facility

- ★ U.S.C.G. life raft facility for Solas commercial yacht and fisherman rafts
- ★ COMAR DEBARKATION LADDERS
- ★ COMAR PILOT LADDERS
- ★ COMAR WORK LADDERS
- ★ All U.S.C.G. approved



"World's longest tested ladder 320ft."

Major Distributor for:











IN SAN DIEGO CALL OCEANS WEST 619 544-1900



IT'S ALL ABOUT POWER.











HONDA MARINE

IT'S ALL ABOUT POWER.





We've been THE Bay Area authority for
inflatables and outboards for more than 35 years.

Call us today for quotes.

Voyager Marine

1296 State St.
P.O. Box 246, Alviso, CA 95002-0246
(408) 263-7633 • (800) 700-7633
Open Tuesday thru Saturday





Welcome to YRA Racing!

Thank you for participating in the YRA! We offer you a choice for racing both on the Bay and on the local ocean!

Entry Form
next page!

FLEET INFORMATION

HDA (Handicapped Divisions Association)

- Bay Racing on longer courses for boats with a current NCPHRF rating. The Vallejo, 2nd Half Opener, and Season Closer Regatta's are included in the HDA Season Racing fee.
- Divisions are determined by grouping similarly rated boats. If you are unsure of your division, please write your NCPHRF rating on the "Fleet" line.
- HDA divisions are invited to race in the Crewed Lightship 1 race for an additional \$5.00 per racer. A signed Minimum Equipment List must be included with entry. Entry into the Crewed Lightship 1 race must be made at the time of season entry or individual race fees will apply.

ODCA (One Design Class Association)

- Bay racing for qualified one-design classes
- The Vallejo, 2nd Half Opener, and Season Closer Regatta's are included in the ODCA Season Racing if the individual class has included the races on their race schedules. Current Fleet schedules can be found on <http://www.yra.org>
- If you are not sure if your fleet is a current ODCA fleet, or would like to sign your fleet up for ODCA, please contact the YRA office at (415) 771-9500 or info@yra.org.

OYRA (Offshore Yacht Racing Association)

- Approximately 12 ocean races ranging from 15 to 51 nautical miles in length
- OYRA racers are invited to race in the Vallejo race for an additional \$5.00 per racer. Entry into the Vallejo race must be made at the time of season entry or individual race fees will apply.
- Racers will race in one of the following 5 divisions, determined by their boats D/L ratio (unless choosing to race in the SHS division):
 - PHRO 1a – NCPHRF of 0 or less
 - PHRO 1 - OVER 31.5 Feet, D/W ratio Less than 200
 - PHRO 2 - OVER 31.5 Feet, D/W ratio 200 & over
 - MORA – 31.5 Feet & Under
 - SHS – Shorthanded division, Specifically Requested

WBRA (Wooden Boat Racing Association)

- The WBRA is a Golden Anchor member in US Sailing and includes US Sailing membership dues in its entry fee
- Bay racing for one of the following 4 fleets:
 - Bird Boats
 - Folkboats
 - IODs
 - Knarrs

BACK FOR ANOTHER GREAT YEAR!

THE YRA PARTY CIRCUIT!

- This series highlights the marquee YRA events: The YRA Season Opener (The Great Vallejo Race) in May, the YRA 2nd Half Opener in July, and the YRA Season Closer in September. Three fun-filled weekend events with great parties on each Saturday night!
- Series Champions will be awarded at the YRA Year-End Trophy Party in November 2009.
- There is one throw out race for the series. In addition, 50% of the fleet or class must qualify for awards to be given.
- All Bay-Area sailors are invited to sign up! We offer divisions for PHRF racers, One-Design Classes, a Double/Singlehanded Division and a Non-Spinnaker Division. If your One-Design Fleet is interested in signing up, please contact the YRA office.
- When entering, simply list your NCPHRF rating on the "Fleet" line, or, enter your One-Design Fleet.
- Sailing Instructions for each race will be available on the YRA Website: www.yra.org. If you have any additional questions, contact the YRA office at (415) 771-9500 or info@yra.org.



GENERAL INFORMATION

- **YRA Sailing Instructions are available on the YRA website at www.yra.org**, or at the YRA office. Sailing instructions are normally posted approximately 2 weeks prior to the race for each charter association. If you do not have access to the internet and need to have your race instructions mailed to you, please contact the YRA office at (415) 771-9500 or info@yra.org
- A YRA sailing membership and a membership in a YRA member yacht club is required to register a boat for any YRA regatta.
- Please fill out your entry form completely, sign, date and return it to the YRA office along with your payment. If you need additional assistance completing this form, please contact the YRA office.



Yacht Racing Association of San Francisco Bay

Quarters 35 S, Fort Mason
San Francisco, CA 94123
Phone: 415.771.9500
Fax: 415.276.2378
email: info@yra.org

Name: _____	Boat Name: _____	Sail Number: _____
Street: _____	Boat Model: _____	
City, State, Zip: _____	Manufacturer: _____	Yr Built: _____
Evening Phone: _____ Daytime Phone: _____	Designer: _____	Yr. Designed: _____
Email Address: _____	U.S. Sailing #: _____	YRA Member #: _____
Yacht Club Affiliation: _____	Marina: _____	Berth/Slip #: _____

Membership Fees:	YRA Membership: Required for YRA Racing	\$40	\$ _____
NCPHRF Fees:	Renewal of 2008 Certificate:	\$30	\$ _____ <i>Please attach NCPHRF renewal form or application</i>
	New Certificate or Renewal of 2007 or prior Certificate:	\$40	\$ _____

Season Racing Fees:	US Sailing Members	Non US Sailing Members	Fleet	<i>See back for more fleet information</i>
Handicap Division Association (HDA) Season	\$180	\$195	_____	\$ _____
One Design Class Association (ODCA) Season	\$180	\$195	_____	\$ _____
Ocean Yacht Racing Association (OYRA) Season *	\$195	\$210	_____	\$ _____
Wooden Boat Racing Association (WBRA) Season <i>(includes US Sailing Membership)</i>	\$190	N/A	_____	\$ _____
YRA Party Circuit <i>A 3 race weekend mini series! See Back for Details</i>	\$120	\$135	_____	\$ _____

Single Race Fees:	US Sailing Members	Non US Sailing Members	Fleet	<i>See back for more fleet information</i>
HDA season racers entering Lightship 1 *	\$5	N/A	_____	\$ _____
OYRA season racers entering Vallejo	\$5	N/A	_____	\$ _____
Vallejo Race Only (YRA Season Opener)	\$75	\$80	_____	\$ _____
2nd Half Opener Only	\$75	\$80	_____	\$ _____
Season Closer Only	\$75	\$80	_____	\$ _____
All other YRA Races (write in race name): _____	\$50	\$55	_____	\$ _____

Racing Late Fees:	1st Deadline	2nd Deadline	
Vallejo Race (YRA Season Opener): 1st deadline- 4/20, Final deadline- 4/29	\$35	\$75	\$ _____
Lightship 1: 1st deadline- 3/9, Final deadline- 3/18	\$35	\$75	\$ _____
All other YRA Races: Rec'd after 5pm Mon and before 5pm the Wed before race	\$35	N/A	\$ _____

No entries accepted after 5pm the Wednesday before the race

* All YRA Racers entering an ocean race or ocean series must submit a signed OYRA Minimum Equipment Requirement List. See http://www.yra.org/OYRA/ocean_safety.html or contact the YRA office for more information.

TOTAL _____

In consideration of being admitted to sailing membership in the Yacht Racing Association of San Francisco Bay (YRA), I agree to abide by "The Racing Rules of Sailing" and the Sailing Instructions of the YRA and the regatta sponsors. I warrant that I will maintain compliance with the YRA Minimum Equipment requirements. To the fullest extent permitted by law, I hereby waive any rights I may have to sue the YRA with respect to personal injury or property damage suffered by myself or my crew as a result of our participation in the YRA and hereby release the race organizers from any liability for such injury or damage.. I further warrant that I have not relied upon any of the above entities or individuals in preparing my yacht for racing.

Signed: _____ Date: _____

Make check payable to YRA. To pay by MasterCard or Visa please provide card info below, including billing street address and zip code

Card Number: _____ Exp Date: _____ CV# _____ Name on Card: _____

Card Holder's Signature: _____ Billing Address: _____

Office use only

C.C. Check Number _____ Amount PD _____ DATE Received in office _____



WORLD

With reports this month on **A Boatload of Summer Sailing Options**, a local charter skipper's **Most Excellent Grenadines Cruise**, and miscellaneous **Charter Notes**.

The Times They Are a Changin' — This Time For the Better

As we go to press, the good old USA is embarking on a bold new beginning. And while the wheels of change are just now beginning to roll, there's already a palpable feeling of hopefulness in the air. With any luck this fresh new perspective will lead consumers to feel confident again about spending their hard-earned greenbacks on everything from cafe lattes to sailing vacations.

We certainly hope so, because there's a world full of alluring charter destinations out there, with late-model boats that are rarin' to go. And as every long-time sailor knows, there's no better tonic for soothing the pressures of life than a week or two of carefree sailing in some idyllic, low-stress vacation spot.

With springtime just a few months away, now's the time to start planning your spring or summer getaway and lock in a reservation for your favorite boat type.

The fact that most North Americans take their big vacations in summertime is convenient because the majority of the world's great chartering destinations offer excellent sailing conditions during our summer months. Let's have a look at the possibilities, starting with those closest to home.

With fewer vacationers traveling to Europe these days, it's an excellent time to visit popular Mediterranean destinations like Croatia.



SUNSAIL

As we often note in these pages, there are many splendid charter venues within a few hours' flight — or drive — from the Bay Area. For starters, we'll remind you that the Channel Islands off the Southern California coast comprise a primo cruising ground with many secure anchorages, sea caves ripe for exploring, and hiking trails that lead to dramatic overlooks. While Catalina's busy Avalon Harbor has the hustle and bustle of a resort town, with lively bars, restaurants and shops, the rest of the island chain is all about serenity and unspoiled natural surroundings. From San Diego to Santa Barbara, at least a half dozen charter operators will be happy to hook you up with a nicely maintained boat for an island cruise.

We featured the greater Puget Sound area last month for good reason. Whether you cruise the American San Juans, the Canadian Gulf Islands, or farther afield, you'll find soothing green vistas around every bend, and plenty of marine facilities for easy, light-air cruising.

Other options for those who prefer to vacation here in the U.S. are the picturesque waterways of 'Downeast' Maine, where charterers can choose from bareboats or historic schooners, and Florida, which offers mellow, tropical sailing conditions out of Key West as well as the Gulf Coast.

Belize, which lies along the Caribbean side of Central America, is also just a few hours' flight from the Bay. Clean, clear water, fabulous snorkeling and uncrowded anchorages are its hallmarks, and its absolute best sailing weather is from now through mid-June. With only two charter outfits operating there, it's a 'sleepers' destination that should be on every charter addict's list.

For those sun seekers who can never seem to get enough rays, sailing the Sea of Cortez in summertime might be the right call. Flights to the La Paz charter base are short, but some choose to take the scenic route and drive down the Baja Peninsula for a little added adventure. Once away from the base you'll spend your time swimming, sunbathing and marveling at the abundance



THE MOORINGS

of marine life within this vast, minimally inhabited region.

If you're in the mood for someplace truly exotic, consider flying out to the picture-perfect islands of Tahiti. Although generally expensive, bareboat rates and provisioning packages are comparable to those in many other venues — and the eye-popping beauty of these chiseled, volcanic isles will etch dreamy tropical images into your memory banks that will remain fresh for years.

They say the peak season in the Eastern Caribbean is during our North American winter. But if ever there was a place that fit the definition of a "year-round sailing destination," the Eastern Caribbean is it. While summer is officially hurricane season, the statistical likelihood of getting walloped by a major storm is something like 1 in 100. The air temps are only about 5-8° warmer than in winter, the easterly trade winds blow almost as consistently, there are far fewer boats in the anchorages and fewer tourists ashore. Also, boat prices are substantially cheaper.



This Moorings' new base at Orhaniye gives easy access to a culturally rich region. Seen here is the historic port of Symi.

The whole of Europe, of course, is also worth considering for a summer escape. The dollar isn't nearly as weak as it was a year ago, yet the number of travelers is still way down. As a result, prime summer sailing venues like the French Riviera, the Italian isles, the Balearics, Greece and Turkey are much less crowded than in boom times.

While we're on the subject, we're happy to report that two new European charter bases have just been announced. Sunsail will open its third Croatian charter base at Pula just in time for spring sailing. Located on the Istrian Peninsula, it is the northernmost of the three, giving access to a culturally rich region that boasts Byzantine, Venetian and Austrian heritage. In a week's charter you might visit pine-fringed beaches, busy fishing villages, beautiful natural harbors, and perhaps Pula's remarkably well-preserved Roman amphitheater. Again, seeing this area now, you'll beat the crowds

which will undoubtedly discover it in the years to come.

The Moorings' new base at Orhaniye, Turkey, is equally enticing. Located on the Hisanoru Peninsula, which juts out to the southeast from Marmaris between the Greek isles of Kos and Rhodes, it gives access to many quiet anchorages as well as centuries-old villages with

remnants of the ancients. The base can serve as a jumping off point for round-trip charters, possibly taking in nearby Greek isles, or for one-directional charters along the famed Turkish coast.

So many possibilities. . . Wherever you

The Eastern Caribbean is a year-round sailing destination, but in the summertime anchorages are much less crowded.



LATITUDE / ANDY



ALL PHOTOS RICHARD GILLETTE

Low season prices were too good for Rod to pass up. The booming winds made interisland passages a thrill.

plan to sail this summer, we suggest you round up a crew of good-natured sailing buddies and lock in a reservation soon. Summer will be here before you know it.

— *latitude/andy*

Cap'n Rich's Excellent Adventure: Sun and Fun in the Grenadines

When my good friend Rod called on a dreary San Francisco day to say he'd booked a boat in the Grenadines and needed crew, I jumped at the opportunity. The following are excerpts from my log of the trip:

After picking up our Beneteau 36 from Barefoot Charters on the Southern end of St. Vincent, we spent the night on the hook at Blue Lagoon. It always feels like coming home for me when I return to my beloved Caribbean. The full moon was shining, and sparkling brightly over the deep blue water. The warm tropical breeze and the sounds of crashing waves on the reef were delightful. The smell of the tropics was so sweet and enchanting. It felt great to be here again.

Lying 18 miles away from St. Vincent, Mustique is a beautiful island that was one of the highlights of our cruise. The seas were running about 12 feet and a strong gusty breeze was blowing 20 to 30 knots with squalls and rain. It was a very wild ride, and Rod and I were shouting *yea ha's* with great enthusiasm. Our top speed was 10.1 knots while surfing down a big wave. Morning brought a beautiful day, and a very beautiful palm-lined beach came into clear view.

Mustique is an incredible island. Rod and I hired Johnny — a Mustique native who knows everyone and every

place — to give us an island tour in his taxi (a truck with seats in the bed).

Most of Mustique is owned by very rich people such as Mick Jagger and Tommy Hilfiger. They've formed the Mustique Company which takes care of everything. The people who work for the Company each get their

own nice home and car, plus free education for their children. When kids get to the 5th grade they are sent to St. Vincent to attend a boarding school where all expenses are paid. The same is true if they wish to go to college. When they return they are guaranteed a job. There is 100% employment, but if you misbehave or cause trouble, you are forced to leave the island.

Everything is manicured and clean. The people are very friendly and seem genuinely happy. That's the thing I love most about the Caribbean, the people. They are always smiling, happy and willing to help. Everyone says "Morning" and truly means it. The culture is so different from the U.S. They have so little in terms of possessions and money compared to us. But they seem to have much more happiness and laughter.

After a great swim and snorkel we readied the boat for our next leg to Mayreau. Again we were treated to 25-knot winds and 10- to 12-foot swells. Sailing a deep broad reach down wind, we did a lot of surfing with the boat and had a great ride, at one point hitting 12.1 knots down the face of a large wave!

We met some really great locals on Mayreau, such as Righteous Robert and his son Robert, who are both big Obama fans. Everywhere we went in the islands the people were in love with Obama, and were so thrilled that America has gotten rid of Bush and Chaney and elected a black man. You can see the joy in their eyes and hear the pride in their speech. I wish we had brought 100 Obama T-shirts with us. They would have made wonderful gifts.

The area called Tobago Cays is definitely a highlight of any trip to the Windward Islands. It's known as the "Jewel in the Crown" of marine tourism in the

area.

The water is absolutely gorgeous — turquoise blue with great visibility. The shorelines are palm-studded with pristine white sand beaches. The Cays have recently become a protected marine park. It's composed of five uninhabited islands surrounded by a huge coral reef called Horseshoe Reef.

We picked up a mooring ball off of Baradal Island, right next to a turtle preserve. Baradal has a great sandy point that sticks out from the island. The Horseshoe Reef is just a few hundred yards away and you can hear the seas coming straight from Africa, then breaking on the coral.

We did some exploring by dinghy on nearby Petit Bateau and found a beautiful palm-lined beach with great views back towards Mayreau and Canouan Islands.

Tobago Cay has the best snorkeling and diving in the area. We took our dinghy and motored around the bend to the Dinghy Passage, a cut in the reef just big enough for dinghies to get through.



We donned our gear and proceeded to work our way into the reef. This was the best snorkeling I have seen in the Caribbean in a long, long time. Hurricanes, global warming and human waste have taken a toll on many reefs, but these were healthy and filled with fish. We saw dozens of species. The coral was absolutely beautiful and the fish were very plentiful. We were the only people snorkeling in the area.

After a beautiful tropical sunset, we had a gourmet meal with some friends on their boat. The stars were out and sparkling in the immense open sky.

On our way back to St. Vincent, we had a great sail up to Bequia's Admiralty Bay and Port Elizabeth. Bequia is a very beautiful island with steep green cliffs and lots of maritime history. The residents are still allowed to hunt and capture two whales a year. Until recently, large sailboats and ships were built on

Hand-hewn wooden fishing boats are the norm in these latitudes. The pace is slow, and life is sweet. Inset: Righteous Robert shows off his political preference.



the beach on the East side of the Island. In fact, Bob Dylan once had a large sailing vessel built there.

There is a great Maritime Museum on the Island, which is definitely worth the visit. Bequia is also famous for its small model boats. There are two really good boat shops where you can watch craftsmen making little wooden vessels in the traditional manner.

We took a tour of the island and saw

In these tropical isles, no color is too bright. In fact, there, hues that we might find gaudy, simply accentuate the brilliant colors of nature.

the hill where six or seven canons protect the harbor. The Islanders take Christmas very seriously. They were all putting up their Christmas lights for the annual lighting contest. There are lots of stores and an open Market in Port Elizabeth. Cruise ships come here, so they're more developed for tourists than the other Islands.

When it came time to return the boat to St. Vincent, our hearts were sad to be leaving. But on our way back to the charter base we had a thrill. Two huge sailfish leaped 15 feet out of the water several times. It was amazing to see. They were huge!

We made our way north, tacking back and forth into the wind and finally arrived back at Blue Lagoon and the Barefoot base on St. Vincent.

We had a great dinner ashore and savored our last night in these beautiful islands. The Barefoot Charter people were really great and the boat was in good condition. They took really good care of us, and we vowed to return again.

— Captain Richard Gillette

Cap'n Rich — Thanks for sharing your insights. Sounds like a fine time indeed. Who says you can't sail the Eastern Caribbean at the end of hurricane season? We'll be sure to send you some Latitude swag for your efforts, and we look forward to hearing about your next charter adventure.

— Ed.

Charter Notes

It's probably safe to say that longtime sailors generally have a greater understanding of the threats to the marine environment than the average lubber does. So it was no surprise that **TMM Yacht**



WORLD OF CHARTERING

Charters founder **Barney Crook** took great pride in facilitating a special **NBC Today Show** segment on the worldwide effects of climate change on fragile ecosystems. TMM recently provided host **Matt Lauer** and his crew with two catamarans in Belize while they filmed near Half Moon Caye.

Beginning his piece scuba diving in the famous Blue Hole, Lauer later explained that **90% of all life on earth** is in some way **dependent on the planet's coral reefs** and, as temperatures rise, the world's reefs have been placed under extraordinary pressure. Lauer was one of several reporters sent to environmentally sensitive locations around the world such as Australia, Iceland and Africa. We applaud NBC for tackling this sobering subject, and kudos to the TMM staff for the role they played in facilitating it.



COURTESY NBC

Far from the usual big city hype, NBC Today Show host Matt Lauer files a report from Belize's famous Blue Hole.

Meanwhile, if you'd like to get out and enjoy such tropical waters before things get too dire, be aware that the slogging economy has inspired virtually every charter company on the planet to offer **special incentives** — **especially on short-notice bookings**. Low season rates in high season, extra charter days at no additional cost, airline discounts, you name it. Business is obviously

slow, so every company we've talked to lately is motivated to haggle a bit. Add to that the fact that **fewer boats** are in the anchorages wherever you go these days while hotels and restaurants are **less crowded**, and you can see why we say this is actually a great time to plan a getaway.

Airfares, by the way, **have come down** lately since the price of crude has dropped dramatically. If you're on a budget — who isn't? — remember that **creative routing** can often save you big bucks. Flying to the Caribbean via JFK or other major East Coast gateways is sometimes worth the hassle, as is flying into an alternate airport. When flying to the **British Virgin Islands**, for example, consider a route to **St. Thomas**, which has more carrier options, then take a ferry from there to the BVI. You know, think outside the box.



Tortola BVI
Belize
The Grenadines

UNIQUELY
TMM



Marisa
TMM Belize

Most charter companies offer blue water & palm trees, but it takes the personalized care of people like Marisa to make your vacation a success.

Like Marisa, everyone at TMM is committed to your complete satisfaction. Our specialized three-location operation offers large company quality with small company service. A combination that is uniquely TMM.



TMM
Yacht Charters
Since 1979

catamarans • monohulls
motor yachts
ownership programs

BRITISH VIRGIN ISLANDS "BEST DEALS ON KEELS"



- Most selection of sailboats 32'-52'
- "Purr" with cats 38'-47'
- Bare boat or skippered
- Best yacht management program

Conch Charters

Est. 1986

NEW YACHTS IN FLEET!

www.conchcharters.com

Email: sailing@conchcharters.com

Call our 'Sails' Office
(USA) (800) 521-8939

Tel (284) 494-4868 • Fax (284) 494-5793

Sail paradise with Conch Charters

CALIFORNIA'S CARIBBEAN CONNECTION

SAN JUAN ISLANDS



6-Day Learn-N-Cruise

Fly to Bellingham, WA and complete your American Sailing Association Basic Sailing through Bareboat Charter Certifications during a Sat - Fri live-aboard week exploring the spectacular San Juan Islands. Tuition only \$1395, including food! (Airfare SFO/OAK to BLI approx. \$350)

No experience like this for the price in the SF Bay Area!



CHARTER
40 Exceptional Yachts
from 30 - 49 feet

25 Years of Sailing Excellence

We certify more Bareboat Skippers than any other school in the Northwest!

1-800-677-7245 • sanjuansailing.com

Real People. Real Sailing. Real Fun.

Sail Cats | Power Cats
Monohulls | Trawlers
Bareboat | Skippered



Real Choices.

Choose CYOA and become part of the family. We've been providing beautifully maintained yachts, personal service and sensible prices to sailors since 1980.



1-800-944-2962
info@cyoacharters.com
www.cyoacharters.com
St. Thomas USVI 00802





DESOLATION SOUND
YACHT CHARTERS LTD
Comox, B.C.

Closest full-service charter base to Desolation Sound & Princess Louisa Inlet

Visit our Website for a preview of our 25' to 54' Power & Sail fleet

Book Your 2009 Charter Now and Get a 5% Early Booking Discount!

charter@desolationsoundyachtcharters.com
www.desolationsoundyachtcharters.com

#101-1819 Beaufort Ave., Comox, BC, Canada V9M 1R9
TOLL FREE 1-877-647-3815 FAX (250) 339-2217

ANACORTES YACHT CHARTERS
PACIFIC NORTHWEST ADVENTURES

Largest Selection of Charter Yachts in the Pacific Northwest

Bareboat & Skippered
Power and Sail 28'-66'
Charter Yacht Ownership
Yachting & ASA Sailing Schools

Celebrating 30 years in 2009!
Rated #1 by Cruising World



Book Now for Discounts up to 15%!
www.ayc.com 800.233.3004

SAUSALITO



LIST MARINE INC.

- Full service engine shop
- We service all makes
- Dockside facilities
- Mobile service trucks



YANMAR
marine 

P.O. BOX 2008 / 69 LIBERTY SHIP WAY • SAUSALITO, CA 94966
Adjacent to Schoonmaker Pt. Marina

415•332•5478
www.listmarine.com

CHANGES

With reports this month from **Woodwind** on the crowds in the British Virgin Islands; from **My Way** on travels to and at Bora Bora, Bali and Borneo; from Fred, **Courtship's** owner, on losing his cat in the Atlantic; from **Verite**, on taking the total cruising plunge from the fast life in D.C. to cruising the Med and crossing the Atlantic; from **Souverein** on doing the Atlantic Rally for Cruisers; and **Cruise Notes**.

Woodwind — 34-ft Gaff Ketch Bruce Smith and Janet Hein Life In The Caribbean (Gig Harbor, Washington)

Just in case the folks back home think that our cruising life here in the Caribbean is a beach . . . yesterday's full moon brought us some bumpy weather. But it was nothing close to the chaos back home in Washington. Even the headlines here in the Caribbean read, *Washington State Will Soon Slide Off The Map!* Well did it?



Our friend Foxy offered my husband Bruce a big bag of fresh fish the other day, but Bruce had to decline because of a food poisoning incident we once had. So Fox, wanting to give us something, returned with a bigggggg lobster and said, "Do'n tell me you done eat dis?!" But my husband turned it down. When I heard the story I shouted at my husband, "What were you thinking?! It was a fish, not a lobster, that tried to kill us. But it was too late, so it was another round of beans for us.

Just about every *Latitude* reader who has done a charter in the British Virgins has been to Foxy's, certainly the most famous bar in the area. Wait until they hear this! In December, the Queen of England made Philicianno 'Foxy' **Above; Jost looking a little bit like Waikiki. Below, Lagerhead the donkey, mowing the lawn and trying to get out of the table saw.**

Callwood a Member of the Order of the British Empire (MBE). Foxy!

Last week I set off to interview singer Eric Stone, but first I had to find him at one of the beach bars on Jost Van Dyke — and there are plenty of them. So I had to make my way down the crowded beach, past the people from the charter boats, the villa guests and the fellas from the gay cruise before I finally found him. And I thought teaching was hard.

Jost has been pleasantly busy. White Bay gets the hit in the day and Great Bay gets 'em at night. It slowed down after New Years, but there's still plenty of business in the BVIs — which is good.

Bruce's job for a month this winter was working on the boat in the accompanying photo — the one behind Lagerhead the donkey. Lagerhead is a great lawnmower, but he leaves a big calling card. Then there was the day his lead got tangled up with the table saw.

The other day I asked Bruce to "trim" my hair. He's an artist, so I figured he could cut a straight line. Besides, it was either him or a West Indian specializing in weaves, braids, extensions and razor cuts. Well, big mistake! My hair is more wobbly than it usually is, and I'm afraid to go to sleep because Bruce is too excited about the "repair cut". He thinks he's Gene Ware; I think he's Bruce Scissorhands.

The thrill of this week was the 'opportunity' to lug two loads of dirty clothes to a laundromat. They had running water for once! That's big news for a laundromat in these parts.

Once this crazy weather breaks, we're going to sail our gaff-rigged ketch across the Anegada Passage to Anguilla. The place to go to there is Elvis' Beach Bar. There are a million stories at that place.

—janet 01/12/09

Janet — Foxy, who celebrated his 60th birthday barefoot aboard *Profigate* on San Francisco Bay with a big spliff, a MBE? Finally, some justice in the world.



My Way — Shuttleworth 70 Cat Don and Karen Engle Bora Bora, Bali and Borneo (Alameda)

My Way has put a lot of miles under her two keels since our last update. It was a short hop from the Tuamotus and Marquesas of French Polynesia to Bora Bora, which is just north of Tahiti. With good protection, crystal clear water and lush foliage ashore, Bora Bora is a perfect location for a sailing holiday. We were joined by family and friends to share some unique underwater sights, as well as time ashore.

After all of us left, the crew took *My Way* on a 6,500-mile downwind passage to Bali, Indonesia. We had to get the boat out of French Polynesia to avoid the South Pacific tropical cyclone season. Bali was chosen as our next destination because it's easy to fly to, and once we'd spent a week there, it would be a relatively short sail to Borneo to see one



IN LATITUDES



ALL PHOTOS COURTESY MY WAY

Spread; Big Tom the alpha male. Insets; playing with rays at Bora Bora, and Don and Karen with their friends the orangutans in back.

of the world's last orangutan habitats.

For most visitors, Bali is a well-developed and affluent Third World resort destination, and it does have wonderful accommodations and great beaches. Nonetheless, we travelled inland to try to enjoy the interesting landscape, culture and wildlife. We found ourselves in Bali during the rainy season, and when it rained, it really came down! We got as wet hiking to a waterfall as we would had we stood under the waterfall. On the way back to the boat, we stopped at a Balinese outdoor food court because we always try to eat local. We have no idea what we were served, but it was delicious.

After exploring Bali, we travelled across the Java Sea toward the Kalamantan region of Borneo. It was supposed to be an easy two-day sail, but at about 3 p.m. on the first day we ran into a dense line of squalls. Even though we'd reefed

the main by 50%, the first gust of wind ripped the main right off the boom! From then on we were caught in terrible conditions. The wind indicator went from 10 to 60 knots in seconds, the seas built and we took a terrific pounding. At times it rained so hard that we couldn't see five feet in front of us. None of the crew ate or slept very much for the next three days. It was the worst time I've ever had at sea.

Once at Kumai, Borneo, we tried to check in with the authorities. They had no idea what to do with us. I think Karen and Sarah were too much for the officials. We then took a small boat six hours up the Kumai River to the preserve, where we were to spend four days with the great apes. As the river

narrowed, the jungle closed in. It seemed as though we were travelling into the heart of darkness. Even so, Karen took a trick at the helm of the boat. Staying in the middle of the river was harder than it looked — and very important.

The apes are not shy, so they came right down to the boat to check us out and welcome us. They seemed very sweet, but they are very strong — 15 times stronger than humans — so we had to be careful. We learned there is only one alpha male per area, and this was Big Tom's territory. He weighs 300 pounds, but despite his bulk he moved through the trees with grace and ease. Even though he was the alpha male, at times Tom was playful. We also saw him accomplish complicated tasks. After humans, these apes are now believed to be the second most intelligent creatures on the planet.

Because orangutan babies stay with their mothers for nearly seven years, almost every female had a baby on her hip. We were allowed to get close enough to check out every detail. We even got to know some of the individuals by name.

On the last day we stopped at a village along the river. Looking inland, we could see that a lot of rain forest had been cleared for planting rice — which is why there is so little orangutan habitat left. The housing in this area of Borneo was simple, but everyone seemed well fed. People in the village were as interested in us as we were in them. Almost everyone had a smile for us.

After a short stay in Thailand, we hope **Above; in Bali, ears of corn are sold by the head. Below, a typical pass in the South Pacific, complete with glorious blue water.**



MY WAY

CHANGES

to take *My Way* to the Mediterranean. That means she'll have to go past the worst pirate area in the world, so Karen has been taking gun training. She's a great shot. There's something attractive about a beautiful woman with a big gun.

— don 01/08/09

Courtship — Venezia 42 Catamaran Fred Tassigny, Jacques Lescureux Disabled By A Whale (St. Barth, French West Indies)

Fred Tassigny and his crew Jacques Lescureux couldn't believe their eyes. It was rough, it was nearly dark, they were "in the middle of nowhere" 350 miles south of Bermuda — and the huge bow bulb on the 600-ft Turkish ship *Gulser Ana* was about to T-bone them! On purpose. You bet they were scared. Seconds after the ship slammed into the 42-ft cat — the second hull-crushing she'd received in eight hours — the ship's massive anchor snagged the cat's mast, bringing the spar and rigging down around Fred and Jacques.

At the time, Fred, a 63-year-old retired civil engineer and contractor was sailing home to St. Barth, the island in the French West Indies where he had lived from '90 to '02. After that, he and his wife Sophy had cruised their Moody 39 *Suzu* all over the Pacific for six years, eventually selling their sloop in New Caledonia. Upon returning to France, they began to search for a catamaran, one they could buy inexpensively because of the strength of the euro and the weakness of

Above; The Coast Guard plane arrived with remarkable dispatch. Below; the crew of 'Gulser Ana' prepare to rescue Fred and Jacques.

the dollar. The search led to Fred buying a '94 Venezia 42 *Courtship* for \$200,000 in Annapolis.

On November 11, after preparing the cat and sailing across the Chesapeake Bay, Fred and his friend Jacques departed Norfolk, Virginia, on the 1,500-mile passage to St. Barth. Because of the time of year, Fred wouldn't be able to buy insurance for the boat until he was farther south. So he left uncovered.

The trip went well until 8:30 a.m. on the morning of November 18, when they were sailing at about seven knots in moderately strong winds and seas.

"We were having breakfast," Fred remembers, "when all of the sudden we felt this soft shock on what seemed to be the bottom of the aft port side of the cat. When we looked back, we saw a huge amount of blood in the water and a wounded whale. His wound was about one foot by three feet. It didn't look like a gash, but rather an overcooked sausage having exploded out of its casing. I was sure he wasn't going to live long."

Fred's theory is that the whale was coming up from sounding, but didn't realize that *Courtship* was there until the last second. Fred thinks the whale tried to avoid the cat, but didn't quite make it.

The damage to *Courtship* was as fatal as it had been to the whale. "The whale's impact bent the port rudder shaft 90 degrees, driving the rudder through the bottom of the aft compartment of the port hull as though it was a giant knife. It had also shoved the saildrive right up through the bottom of the boat and into the engine compartment. Water started pouring in."

The Venezia's are, unfortunately in this case, built with a tube for the steering that goes from one engine compartment to the other. With all the water in the port engine compartment, the boat started to settle to aft with a port list. Once that compartment was full, water started flowing through the steering tube to the starboard engine compartment, flooding that one also. The boat leveled out transom down, which permitted some of the larger seas to break into the cockpit. Since the



dual rudders are moved by a single system, the boat couldn't be pointed into the wind. The little bilge pumps were no match for the ingress of water, so Fred and Jacques tried bailing with buckets — and everything else they could think of — but to no avail.

Three hours after *Courtship* was hit and had become completely disabled, Fred, 63, decided there was no way they could save his uninsured cat. When his *mayday* call over the VHF went unanswered, he set off his EPIRB. It's a bit ironic, because he'd always been skeptical of EPIRBs. He wasn't going to take one until retired ocean sailor Tom Knoedler offered him his for a few bucks. Fortunately, Fred took a few minutes to reregister the device over the Internet.

An hour later, a Norfolk-based Coast Guard plane flew overhead and asked if they had an emergency. When told their cat was disabled, Coast Guard arranged for the Turkish ship *Gulser Ana* to divert to save the two Frenchman. Less than



IN LATITUDES



LATITUDE/RICHARD

Sitting at the Le Select Bar, Fred struggles to convey his feelings about losing his catamaran to a whale that probably meant no harm.

four hours after setting off the EPIRB, Fred and Jacques watched as the Turkish ship, on its way from Tampa to the Black Sea with a load of scrap metal, come into view.

It's not easy for a 600-foot ship, which has to keep moving to have steerage, to sidle up to a 43-ft sailboat in an attempt to remove crew. The ship's captain, whom Fred describes as "fantastic," made three runs at it. None of them was close enough for Fred and Jacques to get off. It was then getting dark, and if the captain wasn't successful on his fourth attempt, the two sailors could be in mortal danger. While there was communication between the ship and the sailboat, it wasn't very good, so Fred and Jacques had no idea what the captain had in mind for his last attempt.

Knowing that failure wasn't an option, the captain decided he would simply T-

bone the sailboat as slowly as he could. Fred and Jacques weren't aware of this plan, which is why they were surprised to see the ship's bulb — "you can't believe how massive it was!" — coming right at them.

After the ship smashed into the sailboat and ripped her mast off, the sailboat slid down the side of the ship in her lee — just as the captain had planned. This gave Fred and Jacques the chance to grab the ladder that had been lowered and scramble aboard.

"I was crying like a child," Fred remembers. "All I was able to escape with was my papers, my Mac computer and a special ukelele I'd bought from an old man in the South

Pacific. I left my whole life in that cat. The ship's captain was a wonderful man, and asked me if I wanted to try and retrieve more stuff. And one of the crew, who happened to be a sailor, volunteered to go for me. But there just wasn't enough valuable stuff.

To prove that much of what happens in our lives is luck, the very same day Fred's uninsured cat had to be left disabled at sea, a good friend of his won a million euro lottery.

Immediately after being rescued, Fred got on the phone to let his wife Sophy know what had happened. She received the phone call during happy hour at the Le Select Bar, so the shocking news spread like wildfire among friends. Fred and Jacques spent the next 11 days on the ship, where they were treated wonderfully. They were finally taken off by a pilot boat at Cueta, the small Spanish enclave surrounded by Morocco just inside the Straits of Gibraltar.

When Fred finally returned to St. Barth, he was \$200,000 poorer. Fortunately, he and Sophy had many kind friends on the island happy to lend a hand, and a sympathetic local bank willing to give him a loan so that he could acquire another boat. So, he and Sophy are now the owners of *Tres Palmeras*, a lovely Beneteau Oceanis 40, and living in the anchorage off Gustavia. Usually the couple spend their summers at a little place they have on Mallorca, but not this year. It looks like they'll get a job managing a sumptuous villa, which will help them earn money toward their goal — finally getting a catamaran.

"No, I haven't given up on my dream," says Fred. "For when you finally give up dreams and making your dreams become

The completely disabled 'Courtship', as seen from the bridge of the 'Gulser Ana', which then intentionally rammed her to save the crew.



GULSER ANA

CHANGES

reality, you might as well pull the trigger on the gun pointed to your head. "I'm an old sailor, which like the whale is an endangered species," he laughs, "but I'm lucky to be alive and to be able to enjoy life among my friends."

— *latitude* 01/13/09

Verite — Catana 50
Ted Halstead and Veronique Bardach
The Total Plunge
(Washington, D.C.)

Ted Halstead, an American who grew up in Belgium before graduating Phi Beta Kappa from Dartmouth, is a quietly persuasive guy. When he was 25, he got enough people to donate money so he could found Redefining Progress, an environmental think tank based in San Francisco. Figuring he'd gotten a little ahead of himself, he then picked up a masters degree at the Kennedy School of Government at Harvard. But before he even graduated, he convinced newsman Bill Moyers to put up \$200,000 so he could found the New America Foundation in Washington, D.C., a nonprofit public policy think tank of which he was president from its inception in '99 until '07. During that time he appeared on all the political talk shows, wrote articles for all the major English-speaking publications and along with Michael Lind coauthored *The Radical Center*, *The Future of American Politics*.

But that was probably all child's play compared to his next conquest — wooing his now wife Veronique. Although she grew up on the Spanish island of Mallorca, she's French by birth, and having become an American lawyer now heads a venture capital company. 'Formidable' is the word that probably describes her best.

"When Ted and I first went out, I told him that I would never marry and that **'Verite', their new Catana 50, as seen against the very blue Mediterranean at Tunisia.**



I would never sail," says the beautiful, intelligent and athletic Veronique. Yet when we met the couple, they'd just completed an 18-day doublehanded passage from the Canary Islands to St. Barth, and they'd been married for nearly two years. It's was further proof of Ted's persuasive powers.

And it's not as though they were experienced sailors before they flew to France last summer to take delivery of their \$1.5 million Catana 52 cat. "We were total beginners," admits Ted. "Before buying our boat, I'd taken a week of sailing lessons and chartered twice in the Virgin Islands. After I met Veronique, we did two more charters. But prior to taking delivery of our boat, we'd never flown a spinnaker and I had no idea what an impeller is. Even after we'd been sailing around the Med for awhile, Veronique was still asking what the boom was and the proper term was for the left side of the boat."

So what caused them to abandon — or at least take a hiatus from — their careers? Part of it is that Ted has the adventure gene. When he was 19, he took off a year from Dartmouth to travel around Central America by car. "The adult version of that seemed to be doing something along those lines with a boat," he says. "Despite being a passionate kite sailor, Veronique was dead set against it. But she does have a wild side, so I managed to convince her."

"He can be very charming," said Veronique wryly, still smarting from their 18-day crossing.

Their lives in Washington, D.C. helped persuade her to give sailing a try. "We were both workaholics," says Ted, "just working all the time — and in a very competitive environment. So when we turned 40 and got married, we decided there had to be more to life."

"He's relentless," chimes in Veronique, with overtones of both admiration and disgust that he was able to talk her into buying what she describes as "the world's most expensive kitchen."

Like all good -aholics, neither Ted nor Veronique has been able to get the working monkey off his/her backs. The prime evidence is that they have five communications systems on their boat to make sure they are never out of touch with the world.

"Our most sophisti-



cated system is our Thrane & Thrane Bgan, which can provide us with broadband voice and data anywhere in the world," says Ted. "That means we were able to download the *New York Times* and other publications wherever we were — including the middle of the Atlantic Ocean. It was expensive to buy and it's expensive to use, so we only use it when our other communication options aren't available. Something fantastic that's available all over Europe but not in the States is the Ericson W25, which is a high speed voice and data wireless gateway. You buy a SIM card for it for between 30 and 50 euros, and it turns the little Ericson box into an onboard wifi base. We were able to use it almost everywhere we went in Europe, which gave us broadband for 30 to 60 euros a month. Our fourth option was our Iridium satphone, while the fifth was our Blackberries, which worked almost everywhere in the world for an international roaming fee of about \$60 U.S. a

IN LATITUDES



SPREAD, MIKE HARKER; INSET, DISTANT DRUM

The persuasive Ted, the formidable Veronique, and the protective Ria pose just a day after finishing their 18-day Atlantic crossing.

month."

Remarkably, the couple say they have no problem switching mental gears from play to work — even while sailing. "The only difficult thing," says Veronique, "was when the people we talk with on the phone realized we were on our boat in the Med, they assumed that we were living the lazy life sipping martinis while watching sunsets. People weren't at all sympathetic when we told them that we spent half our time working, half our time doing maintenance on the boat, and half the time sailing, kiteboarding, hiking and pursuing other hobbies. The 'three halves' were always competing for their fair share of the time."

"It's true that various communications systems and commitments to work keep us anchored to our past," Ted admits, "but we have to because we're not trust fund kids. Both of us were lucky to

get out of school without much debt, but even as the head of a nonprofit you don't make much money. So we've only had enough to buy this boat and to live the lifestyle for a couple of years; we're certainly not retiring forever. Fortunately, I got lucky with a land investment, and I'm running the development of some oceanfront property in Costa Rica near the border with Nicaragua. That helps out."

In addition to not knowing much about sailing before buying their boat, the dynamic couple didn't know anything about boats. As Ted explains, "After we went to the Paris Boat Show and ordered our boat, we assumed that all we'd have to do was pick her up from the factory in Canet, add fuel and oil, and enjoy ourselves."

"Canet should be

renamed Hell," interjects Veronique, "because it blows 360 days a year, and is a blue collar town with no decent restaurants. We spent a month there waiting for our boat to be done."

And even when it was done, it wasn't really done. "We ran into problem after problem," says Ted. "There was an error with the spreaders, so they had to be replaced. The problems with the saildrives was so unremitting that Volvo finally had to recall them all. The anti-fouling didn't work and had to be redone, and all the Raymarine Electronics except for the autopilot had to be replaced. To be fair, most of the problems were with boat systems and not the boat, and Catana fixed all of them for free."

Ironically, the fact that there were so many problems might have saved the couple's butts. The anticipated two weeks of time necessary to do the repairs at the factory turned into four weeks, and that meant they weren't at Andraix, Mallorca, as planned on November 2. That was a good thing, because Andraix was swept by 120 mph winds that destroyed over 100 boats and ruined much of the just-completed infrastructure at the beautiful little town.

Despite the steep learning curve and problems, don't get the idea the couple didn't have lots of good adventures and fun. They loved sailing Spain's Balearic Islands of Mallorca and Ibiza, although the latter is where they managed to bend the shank of an anchor in 45-knot winds. They enjoyed their stops at Tunisia, Italy and Croatia before making their way through Greece's Corinth Canal.

"We really enjoyed Greece," says Veronique. "Heaven to us is a white sand beach, great people, plus good kiteboarding conditions, and Greece had it all. But rather than the more popular spots such as Mykonos and Santorini, we really liked the quieter places like

The kiteboarding conditions at islands such as Paros are just what Ted and Veronique were looking for. So were the warm people.



P.P. PAROSISOKI

CHANGES

Naxos, which is really pretty, and Paros. We'd walk up to the villages on the hills and meet wonderful locals. The farmers would take us in and give us fruit and goat butter, and people would take us to things like breadcooking ceremonies. It was all very friendly and personal. We loved it — it's been the highlight of our travels to date."

"We also loved the whole cruising community, which was unbelievably generous," says Ted. "They took us novices under their wing so many times. For example, the first time we dragged anchor, some other cruising skippers came over to help us out. And when we had to do a minor repair to the hull, other cruisers showed us how to apply gel coat. When we had to repaint our bottom, eight cruisers came to the yard and helped us from 8 a.m. to 6 p.m., with a stop for wine and cheese. Time and time again we were wowed by the unselfish generosity of cruisers. It was really something after the cutthroat world of Washington, D.C."

The couple wanted to continue to Turkey, but ran out of time. In fact, they ran so short of time that Ted had to attend a business meeting and leave Veronique — still very much the novice — to sail *Verite* from Crete to France. It might not have been so bad had she more experienced crew than her 72-year-old mother and a distant relative who had assumed Ted was going to be along.

"It was the best idea ever," says Ted, who no doubt enthusiastically sees the bright side of every dark situation. "Veronique had no choice but to take charge for those two weeks, so she grabbed the bull by the horns — and learned a lot in the process. You see, she normally drives the boat in port, but doesn't do the lines or trim the sails. But on the sail from

Croatia was clean and beautiful, with great hiking and welcoming people. Alas, they were a little cold and there was no music in the streets.

Crete to France, she had to do it all."

Veronique doesn't exactly agree with Ted's evaluation. "It was very hard," she declares. "I hated Ted for making me do it."

Perhaps sensing he was in danger of having to sleep in a single bunk for a week or more, Ted rallied. "You should have seen the meal that Veronique prepared for us on Christmas Eve. It was worthy of the best restaurants in the world." When Veronique gives him a withering look, Ted pours it on: "Veronique cooks like the French, has the passion of a Latin, and as a lawyer and an entrepreneur she is as American as can be."

"Isn't he sweet?" Veronique counters with that familiar look of admiration and disgust.

The closest the couple had to a big disaster was motoring up a channel in Montenegro. "We were naked because we like to sail that way," says Ted. "We were both inside, and because of the layout of the salon, there are some obstructions in the view forward. And we weren't aware that fast ferries charge back and forth across the channel at high speed. By the time I saw one, we were just feet from slamming into it. As I ran to the helm, which is way out on top of the hull, I could clearly see the alarmed expressions on the passengers on the ferry — who were grabbing the rails in fear. I turned off the autopilot and threw our boat into reverse, and just managed to avoid the collision. I remember yelling to Veronique, "Clothes, clothes — bring me some clothes! We later learned that these ferry captains get their kicks by coming as close to other boats as possible."

Croatia is a current cruising hot spot, but the Halsteads had mixed feelings about it. "The Croatians love Americans and feel a lot of gratitude for what we did for them, and that was great," says Ted.

"But while they are very welcoming and nice, we found them to be a little cold," adds Veronique. "They are very Eastern Bloc in that they don't come across as being that happy and there is no music in the streets."

"On the other hand," continues Ted, "Croatia is



what I imagine what sailing is the South Pacific must be like, with lots of completely isolated places. And the Adriatic Sea was so clean, with fjords everywhere. In addition, Croatia has alpine trees on the hills, which made for great hiking, and there was no trash anywhere. The less known places were very reasonably priced, but we had to pay \$60/night at Dubrovnik."

The Med can be extremely expensive, but Veronique found the quality and prices of food to be reasonable if you knew where to shop. And given her European upbringing, she knew just where to look. "There are great farmers' markets everywhere in Europe, and if you look for fresh local foods, they are reasonably priced."

The Halsteads cruised with Ria, their mixed breed dog. However, we're forbidden to disclose any further information on their pet, or to explain why he ended up travelling to Europe first class with Veronique — while Ted went coach. But apparently there are limits to Ted's persuasive powers.





PHOTOS COURTESY SOUVERAIN

Spread; 'Souverain' charges across the ARC finish line in St. Lucia. Inset; Yancee, Dennis, Jason and Capt. Phil after the finish.

Having finished a long 18-day passage only the day before we spoke to them, that was naturally in the forefront of their minds. Crossing the Atlantic is a major undertaking for any crew — to say nothing of a couple of ocean virgins. Had they considered taking crew? "We went back and forth on that idea," says Ted. "Some folks said we'd need it, some said we wouldn't. In the end, we decided to go without. For us, it was the right decision."

As it was, in an eight-month period they went from not knowing anything about sailing or boats to successfully doublehanding the Atlantic in robust conditions. "It was a challenge, but a lot of fun," says Ted. After being given a look by Veronique, he amended his description. "Veronique learned that she doesn't love ocean passages, but she was a real trooper. I, on the other hand, had a blast! It was all about freedom, self-discovery and adventure. How cool of a

honeymoon!"

"Usually honeymoons cater to the desires of the new wife," Veronique reminded Ted. "My husband sweet-talked me into this."

Spencer Tracy and Katherine Hepburn had nothing on this passionate couple.

— *latitude 01/02/09*

**Souverain — H-R 53
Phil Stolp and Crew
The '08 ARC
(Marin Yacht Club)**

I had the good fortune to crew aboard Phil Stolp's Marin Yacht Club-based H-R 53 *Souverain* during the November-December Atlantic Rally for Cruisers '08 from Las Palmas, Gran Canaria, to Rodney Bay, St. Lucia. I feel very much indebted to the captain for the experience, as do my two crewmates, Yancee Knowles and Dennis Hammer.

After a vigorous week of provisioning and outfitting

in the accommodating environs of Las Palmas, the fleet of some 225 vessels set out on November 22 in two starts separated by just 15 minutes. The sight of Oyster 80s sparring with Beneteau 32s, all in a mad dash for the start, gave a new definition to the term 'deductible'. We had an excellent view of the ruckus, as we started upwind of the reaching fleet on a true DDW course with twin headsails.

We would use this twin-headsail configuration for nearly 75% of the 2,885-mile passage. The self-furling forestay was equipped with two tracks, allowing us to fly the genoa at the same time as the jib. This setup offered three advantages: First, with the boom acting as a whisker pole to the genoa and prevented forward to a bow cleat, there was no threat of accidental jibes. Second, when squalls approached, it was an easy task for one person to shorten both foresails on the single furler. Lastly, when our course happened to be directly downwind, the two foresails allow you to maintain DDW. The disadvantage, however, was a less comfortable ride, as the swell never truly aligned with the wind. We had quartering seas for most of the 19 days.

By sunset on the first day, we found ourselves alone within our six-mile horizon, the bulk of the fleet having been forced ESE due to their spinnaker sets. A SSB network had been prearranged, which we reported to daily with our position and engine hours. Boats with the capability could also report their information via email directly to the race organizers. The positions were then posted on a website so that interested parties could follow along as each vessel inched across the Atlantic.

Unqualified kudos are due to the **Many of the residents of Las Palmas turned out on November 22 for the start of another massive Atlantic Rally for Cruisers.**



SOUVERAIN

CHANGES

World Cruising Club for the job they did organizing and managing the event. The splendor of our departure, which it seemed the entire population of Las Palmas had come out to witness, was only undone by the warmth of our welcome upon landing in St. Lucia.

Predominantly light trades and rigid



Fish on!

airline schedules forced our captain to engage the 'underwater spinner' — crewman Hammer's term — more than he would have otherwise preferred. Still, by the 19th day out, we had caught more fish than we could eat, gotten more than is dermatologically advised, heard each others' jokes four times and somehow became better sailors and friends despite ourselves.

The Halberg-Rassy performed as billed — sturdy and comfortable, accommodating the crew of four quite spaciouly. A tepid freezer and a reluctant water pump were the only technical difficulties encountered.

I would recommend the ARC to any yacht leaving the Med for the West Indies. The competition and camaraderie enliven what would otherwise be a long, lonely run. On behalf of the crew, thanks again to Capt. Phil Stolp for giving us the opportunity of a lifetime. Hail *Souverain*; long may she reign.

— jason 01/15/09

Rodney Bay in St. Lucia has always been a great place to finish the ARC, even as seen here in '96, before it was completely remodeled.

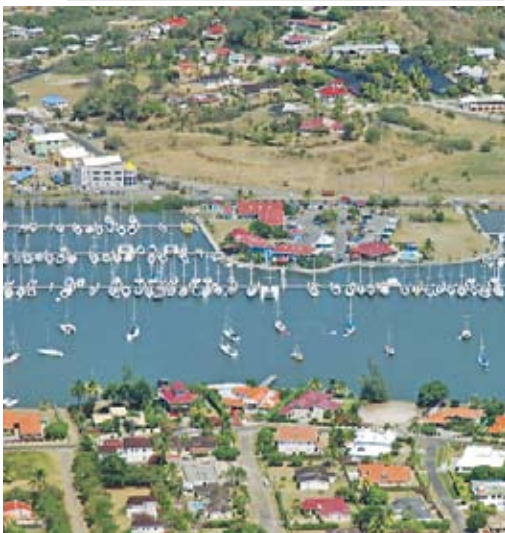

Zephyra — Morgan Out-Island 41 Russ and Debbie Noorda Waste of Time and Money (Lake Tahoe)

We understand that we're guests in Mexico and should not complain about following the rules. Since doing the '07 Ha-Ha, we've found officials in Mexico to be easy to get along with, and have had no problems checking in and out, and following other procedures. That said, we want southbound boats to know what they could be getting themselves into at Puerto Madero, which is on the southeast side of the Gulf of Tehuantepec, just 20 miles or so from the Guatemalan border.

We arrived at Puerto Madero at 9 a.m. wanting to get fuel as it's about half the price of what can be found in El Salvador. The cruising guides said we could sleep at Puerto Madero without a hassle after crossing the Tehuantepec. But as soon as we reached the channel, the port captain called us on the radio and told us that even if we were only getting fuel, we'd have to check in and out again. It didn't matter to him that we'd already checked out of Mexico. He then gave us instructions we couldn't understand about where we should anchor. Suddenly there was a 'Thump!', and we'd hit bottom — even though the depthsounder beneath our galley was reading 18.6 feet! A two-knot current was pushing us against the hidden shoal in the channel. The port captain kept shouting directions at us until we got him to understand that we were stuck. He said he would send the Navy to pull us off — and to do our "inspection." By the time the Navy arrived, we were heeled over so far there was no way for them to pull us off, so they just did the inspection. The 'they' was an officer, seven guys with M-16s and a drug dog. None of them spoke English.

By the time the officer boarded *Zephyra* to fill out the paperwork, we were heeled over 30 degrees and the leeward port light was underwater! He asked if they could bring the drug dog aboard, even though the dog was clearly not a happy puppy about the prospect of getting on a boat that was so far from level. After they left, the Navy boat came back with another officer to fill out more stuff on the forms. After the Navy left the second time, we were floating, so we fired up the engine and asked the port captain if we could get fuel. He said the fuel dock was open until 6 p.m., but that he was closing up in 45 minutes. That meant we had to inflate our packed-away dinghy to



row to shore with all the paperwork they might want. Once at the port captain's office, we signed their papers, paid our fee — and were told that after we got fuel, we'd need to go to the API office, which they said was a short cab ride from the fuel dock. Then before we left Puerto Madera, we'd need to be re-inspected by the Navy and return to the port captain's office!

We purchased our fuel, re-anchored our boat by the fuel dock, rowed to shore, and found someone to exchange dollars for pesos as dollars wouldn't be accepted. We waited so long for a cab that a local businessman felt sorry for us and gave us a ride! We paid another little fee at API and were given some paperwork for the port captain. Since there were no cabs around, we started walking back to the fuel dock. But it was getting dark, and we soon realized that we didn't know the way. We finally found a cab and got back to *Zephyra* just before dark. At that point there was nothing for us to do but relax and spend the night on the hook.

We called the port captain the next morning to arrange to be inspected by

KEVIN STEWART



An on-board fire is the worst nightmare of most sailors. This boat was uninsured when it burned at Bonaire — the owners lost everything.

the navy again. Once again, eight men carrying weapons and a drug dog came out to inspect our boat and fill out more paperwork. After completing the inspection, they told us to go to the port captain's office, so we re-anchored in front of the office, rowed to shore, and paid the port captain another visit. He told us we were free to leave. We raised the dinghy, secured it to the deck, and motored out of Puerto Madera at about noon on Wednesday. This little episode cost us approximately \$30 and 26 hours of our time. So we're warning all south-bound boats that have checked out of Mexico not to stop at Puerto Madero.

— russ and debbie 12/24/08

Cruise Notes:

We're not sure what kind of boat Kevin Stewart has or where he is from, but he was on Bonaire in December when he took the accompanying photo of the **sailboat engulfed in flames**. "The owners weren't aboard when the

fire started, and they returned to see flames pouring out of the interior of their boat. I was told they had no insurance. If that's correct, they lost everything, as the boat — still aflame — was towed to deeper water and allowed to sink. It made me wonder about my boat. I now look at all the electrical stuff on my boat with great suspicion. By the way, Bonaire is still a beautiful island, and compared to Aruba and Curacao — the other two 'ABC Islands' — is positively heaven."

No matter if it's a ship, a powerboat or a sailboat, or if it's at sea or at a dock, a burning vessel is a terrifying thing because it's so hard to extinguish the flames. The fear of fire is probably the greatest reason we carry a liferaft. So be careful out there — and make sure your crew knows how to shut off the power sources to prevent shorts from becoming fires.

We only intermittently hear from long-time cruisers Fred

Roswold and Judy Jensen of the Seattle-based Serendipity 43 **Wings**. Some readers may remember theirs as one of the many boats caught in nearly three weeks of extremely stormy conditions between Tonga/Fiji and New Zealand in November of '99. It was so bad that four cruisers lost their lives, four boats were lost and many others badly damaged. Fred and Judy on *Wings* came through in about as good shape as anyone. Anyway, we recently received an electronic Christmas card from the couple in Bangkok, and had to ask them if the rumors about their working again were true.

"We *are* working again because we have this need to eat," Fred responded. "Seriously, we need to have this one last job — famous last words — in order to retire for good. Judy has an audio transcription business she runs from home, which is a condo in downtown Bangkok, while I'm working at IBM on a big banking project. We've been here 2.5 years and this is my second Bangkok job. We kept *Wings* at Raffles Marina in Singapore for over a year, and we'd fly down twice a month from Bangkok to go sailing. But we've kept the boat in Phuket since a year ago November. We travel to her with about the same frequency to go sailing. Phuket is great! We've been doing some racing there — although we did more in Singapore — as well as local cruising and boat projects. We raced the King's Cup in '06 and won our class convincingly, sailed the Phang Nga Bay Regatta in '07 and got second — and are planning to compete even harder in that one again in January. We've got new sails, a good crew and we've taken about 3,000 pounds off the boat. *Wings* will be the lightest she's been since '86 for this race. We're also working hard to lower the rating — it's a process of continuous improvement. We like our condo

Fred and Judy love Thailand because the weather is good, the food is spicy, the prices are reasonable and the living is easy.



TI WANHAN

CHANGES

in Bangkok and our life in Thailand, as the weather is good, the food is spicy, the prices are reasonable and the living is easy. We'd rather be touring Europe or something instead of working, but since we have to work, we're glad we have these jobs. And Thailand is a good place to work. Our intention is to work until the end of next July, then cruise Malaysia for a few months before heading west again. I want to get to Europe."

For those not familiar with the Serendipity 43s, they are flush deck Peterson-designed racing boats with running backstays that kicked ass in the early 80s. We're impressed that Fred and Judy have cruised such a boat for so long.

If you think alcohol has a big effect on men's lives, think of the effect women have. Having finished his 11-month solo circumnavigation earlier this year, Manhattan Beach's Mike Harker showed up at St. Barth on New Year's aboard his Hunter 49 **Wanderlust 3** with some big news — after a lifetime of abstinence, he's taken up drinking. In moderation, of course. "I had two young German nurses sailing with me, and they prescribed a glass of wine three times a week for my



MIKE HARKER

Kimberly of Montreal enjoys a freshwater transom washdown. She's joined Harker on 'Wanderlust 3' on three occasions already.

health. So I obliged them. But just one glass, and just three to five times a week. My sailing plans are to be at the Heineken Regatta in St. Martin in March, then spend all of April in Antigua. Since I've

already done a westaround circumnavigation, I'll then take off on an eastaround circumnavigation. That means Croatia next summer and Thailand next New Year's. If any young nurses are looking to crew, they should contact me."

"Interested in another comparison between medical care in Mexico and California?" writes Jim Prevo of the La Cruz-based Hunter 34.5 **Meridiano**. "I had a sore on my nose that wouldn't heal. A doctor anchored nearby said he thought it might be skin cancer, so I went to see Dr. Eduardo Cervantes, a dermatologist here in Puerto Vallarta. He said he couldn't be sure it wasn't cancer without doing some tests. Since I needed to go back to the U.S. to renew my visa, I decided to visit a clinic in Nogales. The doctor at the clinic told me the only dermatologist for Nogales comes from Tucson and only once a month. Not only that, but he probably wouldn't be able to see me for four months or more! I figured that the thing on my nose would be twice as big by then, so I returned to Puerto Vallarta and the dermatologist I had originally seen. He saw me right away,



DISCOUNTS, DISCOUNTS, DISCOUNTS!

SAN FRANCISCO BOAT WORKS

835 Terry A. François St., San Francisco, CA 94158
(415) 626-3275 Fax (415) 626-9172

www.sfboatworks.com info@sfboatworks.net

Be our guest for lunch at the historic Ramp Restaurant*

*Some restrictions apply



We're so close, you could SWIM over for

BIG WINTER DISCOUNTS

and

GIFT CERTIFICATES

Redeemable for parts and service!



and quickly called in a plastic surgeon. Twenty minutes later they ushered me into an ultramodern room, where they spent 15 minutes removing the sore from my nose. They took a few extra seconds to snip off a skin tag from my eyelid. It's been over a month now, and everything has healed nicely."

Open wide. Wider please! We've often written about how pleased cruisers have generally been with the quality and low cost of medical and dental care in Mexico, but recently we received a bad report. It came from Bruce Balan of the Cross 46 **Migration** — now in French Polynesia — who, along with his girlfriend Alene Rice, visited a dentist very popular with cruisers in Puerto Vallarta. For the life of us, we can't find Balan's email or we'd report the dentist's name. Anyway, after examining Rice, the dentist told her that more than 10 of her fillings were cracked and needed to be replaced. Wanting a second opinion, Rice visited her dentist back in the States, who maintained her fillings were just fine. We suppose it might have been a judgment call, but we'll let you digest that information your

own way.

In our annual 'you don't know how bad weather can get' item from Alaska, Rick and Jen Fleischman of the Catalina 50 **Bob** sent the accompanying photo from the lodge they are watching again this winter at Warm Springs Bay. "The snow started on Christmas evening, and has pretty much been coming down ever since. We've had nine feet in just a few days, so we've been busy snow-blowing and shoveling every day. But the sun actually came all the way above the mountains today, which meant that for the first time in months Jen was able to see both the top and bottom of it."

To each his own, of course, but how anybody could spend a winter in Alaska is beyond us.

"Our boat summered at Puerto Amis-



Given the fact that the tropics exist, it's puzzling to us why any sailors would spend the winter at Warm Springs Bay, Alaska.

tad in Bahia de Caraquez, Ecuador, while we visited family and taught sailing at Ipswich, Massachusetts for 10 weeks," report Chris and Heather Stockard of the Juneau-based Saga 43 **Legacy**. "At the beginning of December, we sailed to Panama's Las Perlas Islands. Sailors passing through the area should not miss this lovely archipelago! We're now at Panama City and will spend a few



MARINA EL CID, MAZATLAN...

A cruiser's paradise in the heart of Mexico's lush tropical coastline and beautiful islands.



YOUR SUMMER HOME IN MEXICO

SUMMER SPECIAL

\$.34/FT/DAY!!

(up to 50')

WELCOME TO MAZATLAN... MARINA EL CID STYLE!

*Complete, Modern Amenities, Including
Marina-Wide High Speed Wireless Internet Connections!*



www.elcid.com

011-52 (669) 916-3468

gcevallos@elcid.com.mx

CHANGES

months in Panamanian waters until the wind dies down and we can head for Tampa. *Legacy* will be dry stored there while we return to Massachusetts to teach kids to sail again this summer. P.S. Thanks for the nice plug for Heather's *Cruising Cook's Guide to Mexico* in the December 19 *Lectronic*."

"Wanting to see more of Costa Rica before crossing to the South Pacific in February, I sailed down from Honduras and had such strong winds off the Cocos headland that I shortened down to a mizzen-sized sail," reports Glenn Tieman of the Southern California-based authentic South Pacific catamaran **Manu Rere**. "After only one week in Cocos improving sails and doing some painting, I continued on to southern Costa Rica. My first day of sailing out of Cocos was excellent. We flew around the western corner, a multitude of islands, and then down the coast. I figured that I would be halfway to Bahia Ballena by dawn, so I was surprised the next morning when I looked at the GPS and saw how little progress I'd made. Just to have a look, I sailed slowly inshore near a prominent hotel. When heading back offshore that



LATITUDE/NICK

A genuine American adventurer, Glenn Tieman is about to head across the Pacific again in one of his most basic self-built catamarans.

night, I saw that the current made a startling wake as it flowed past a fishing buoy a couple of miles offshore. Even though the water was rather deep there, I anchored to wait for enough wind to

progress against the current. During the next two days I anchored in the calms, then raised the anchor — good upper body exercise — and sailed when a sailable breeze came up. I repeated this cycle several times each day and night. At dawn on the third day I was stunned to find myself once again anchored off that same darn hotel! The way I see it, this kind of challenge is the way the sailing sport plays out. In order to minimize the effects of the current, I sailed only about a hundred meters outside the surf. I made Bahia Ballena the following day. This is a nice place with a tiny fishing village, some tourism and a store. Day and night I hear the roars of the howler monkeys in the jungle. Yesterday I sat on the banks of a river under a troop of monkeys gamboling in the tangle of lianas above. Iguanas are as common as squirrels in California, and a snake dropped out of a tree next to me while I hiked. There were fish in the river, but I didn't see any cichlids. I plan to sail to Drakes Bay, spend January in Golfoito, then head to the South Pacific."

If case anyone has forgotten, Tie-



INCREDIBLE SAVINGS ON FUEL AT MARINA CORAL!
Call for a quote ~ 866•302•0066



- The only fuel dock & best launch ramp in Ensenada
- Concrete docks from 30' to 65' with 110v/220v elect., water, cable TV, phone service and wireless internet, laundry, marine chandlery.
- Enjoy the amenities of the 147 ocean view suite resort which will make your stay the most enjoyable.

www.hotelcoral.com

Reservations toll free 1-866-302-0066

E-mail: marina@hotelcoral.com Fax-011526461750058 VHF 71
Carretera Tijuana-Ensenada Km. 103, No 3421 Zona Playitas, Ensenada, B.C. C.P. 22860



**We help make
El Salvador
worth the trip!**

Visit our Web site
www.barillasmarina.com
to learn more about our
many amenities including
high speed Internet,
on-site customs and
24-hour security.



Barillas Marina Club is the premier cruising destination in El Salvador. We are Located in Jiquilisco Bay, the largest Bay in El Salvador. Make Barillas Marina Club your headquarters in Central America and experience the difference that makes us a preferred destination.

www.barillasmarina.com

(503) 2675-1131 • info@barillasmarina.com

man previously spent 10 years sailing a homebuilt 26-ft cat from California to Southeast Asia, living on \$1 to \$3 a day. Like his current cat, which he built for \$14,000, his previous cat had no engine.

"My boat is back home from the Ha-Ha after a quick trip to La Paz and a long delay in Mag Bay waiting for parts for **Nirvana**, our friend's boat," reports Holly Scott of the Newport Beach-based Cal 40 **Mahalo**. "*Nirvana* is about two weeks behind us, but finally in motion again. While waiting out a blow in Ensenada, we came across a new cruising couple, Ken and Lori Embrey aboard the Catalina 30 **Esprit**. They are great folks — and great musicians. If anyone crosses paths with them, they should check out their music."

"There was quite a New Year's fireworks show in Zihua for those of us anchored off La Ropa Beach," report Barritt Neal and Renee Blaul of the San Diego-based Peterson 44 **Serendipity**. "In fact, it looked like *Apocalypse Now* with the big time fireworks exploding directly overhead for half an hour,

showering us with debris. My sister and husband were aboard, but none of us had been right in the middle of a fireworks show before. The firing tubes, about eight inches in diameter, were still on the beach the next morning, and we discovered that they couldn't have been pointed any more accurately at *Serendipity*. We later took our boat to Ixtapa Marina because of some fridge problems.

I was BBQ-ing while tied up there, and looked off the stern to see a dinner guest come cruising by . . . all eight or nine feet of him/her! It was a bit unnerving, to say the least, as you don't expect to see a croc so close. By the way, please include *Serendipity* among the boats planning to participate in the Revived Sea of Cortez Sailing Week out of La Paz on April 1. It sounds like the kind of fun we don't want



SERENITY

Coming from California, Barritt just didn't expect to see a croc swimming through the marina at Ixtapa. It was so prehistoric.

to miss!"

"After doing the Ha-Ha, we headed south to Panama, transited the Canal, and finally reached Majahual, Quintana Roo, Mexico, on December 26," reports Gary Burgin of the Oregon-based Marples 55 cat **Crystal Blue Persuasion**. "It took us a little longer than anticipated. Given that **Profligate** made it from Cabo



OWL HARBOR MARINA THE FRIENDLY MARINA

**HOME OF
ANDREAS COVE YACHT CLUB
Limited Time Only
\$100 Memberships
Call for details**

- 30'-50' deep draft berths @\$5.50 per foot
- Dry and open storage
- Extra wide berths for multihulls
- Home of Club Rio Sailing School

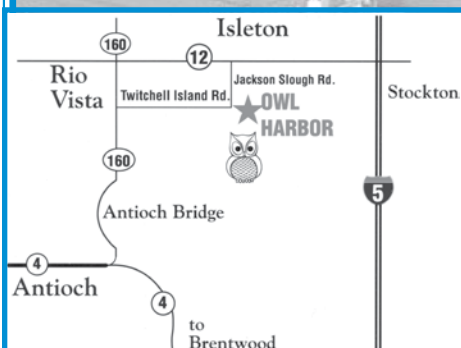

'CANVAS BY THE LOOP' On-site canvas & repair shop

- SAIL - Alterations & Repair
- CANVAS - New & Repairs
- SAILBOAT RIGGING
- HARDWARE INSTALLATIONS
- 12-VOLT REPAIR & INSTALLATION
- FAST TURNAROUND ON REPAIRS

LOCATED ON SEVEN MILE SLOUGH
OFF THE SAN JOAQUIN RIVER

HARBORMASTER: SHAWN PASSERI

(916) 777-6055

email: shawn@owlharbor.com
www.owlharbormarina.com

1550 W. TWICHELL ISLAND RD.
ISLETON, CA 95641

CHANGES

to the Canal in 11 days in '03, I was hoping to make it to Panama in 8 to 10 days. We couldn't, but our time wasn't too bad. Once we got through the Canal, we made it from Colon to Majahual in just 96 hours. Majahual is a fishing village with a cruise ship pier on the so-called 'Mayan Coast' of Mexico. My goal is to use the cat for day charters."

Folks using *Profligate's* time of 11 days from Cabo to the Panama Canal as a point of reference are asking for disappointment, as the crew of Doña de Mallorca, Wayne Meretsky, Paul Biery, Mike Highfield, Steve Arehart and Sarah Terry charged pedal-to-the-metal the entire way. The fuel stops were very brief: 45 minutes at Barra, six hours at Acapulco, and three hours at Puesto del Sol, Nicaragua. As a result, *Profligate* averaged 8.3 knots for the 2,200-odd miles. Despite having to haul at Vacamonte, Panama to replace both saildrives, and then take time to transit the Canal, and make stops at Cartagena and Aruba, the crew managed to reach Antigua by December 6, having covered the 3,402 miles from Cabo in just 29 days. It was quite an achievement for the crew — and



ED SHIVARIO

It's a long way to the Panama Canal, but nowhere near as long as if cruisers had to round South America and Cape Horn.

the cat's little 56-hp Yanmar diesels. But it's not something we'd recommend others try to duplicate.

"Hello, from Isla San Benedicto, one of Mexico's Revillagigedo Islands, which are

about 250 miles south of Cabo San Lucas, and are often included in lists of the 'World's Top Ten Dive Sites'," write Scott and Cindy Stolnitz of the Marina del Rey-based Switch 51 cat **Beach House**. "We've been diving with the manta rays and hammerhead sharks, and have seen the giant mantas on about half of the dives we've done. This is diving heaven, as there are also about seven species of pelagic sharks endemic to the islands. We've taken fabulous video and still photographs, but there is no way for us to share them until we get back to the mainland. Volcanic in origin, the Revillagigedos consist of Isla San Benedicto, which most recently erupted in '52, as well as Socorro, Roca Partida and Isla Clarion. They are often referred to as the 'Mexican Galapagos.' Socorro is the largest of these islands and has a Mexican Navy base located on the southwest corner. The Navy's primary purpose is to patrol and enforce the 'no take zone' for commercial fishing vessels. The zone extends to 12 miles around each island. There are *no* services at any of the islands, so mariners have to assume that

LOCH LOMOND MARINA

**WINTER
SPECIAL**
New Tenants 3rd Month
FREE

**Completely Rebuilt Marina • Gas & Diesel Fuel Dock
Free Pump Out Station • Modern Launch Ramp
Guest Slips Available • Marine Mechanical Boat Repair
Arena Marine Supply Store • Loch Lomond Market**

110 Loch Lomond Drive, San Rafael, CA 94901

Phone: (415) 454-7228 • Fax: (415) 454-6154

www.lochlomondmarina.com

Harbor Master – Pat Lopez • pat@lochlomondmarina.com



they are truly offshore and need to be self-sufficient.

"Readers may remember when officials didn't want private vessels to visit the Revillagigedos," the Stolnitzes continue, "but they've been encouraging it since '06. That's because they want all the eyes possible at the islands to watch for illegal fishing. Permits are required to visit the islands. As of January, about 12 private vessel permits had been requested and issued this year, and about an equal number of permits for commercial vessels. There is no charge for the permits, but getting one is a little complicated and takes a little bit of time. First, you must gather the originals — not copies — of your vessel documentation, insurance, the passports of all members of the crew and their visas. All these must be presented to Sr. Carlos Eduardo Narro Flores, who for the last three years has been the Director del Area Protección de Flora y Fauna de Cabo San Lucas Reserva de la Biosfera Archipiélagos de Revillagigedos. You'll also have to give him a letter, preferably in Spanish, explaining why you want to visit the

islands. You should include the dates you would like to visit them. Because of the vagaries of boats, crews, provisioning and weather, we suggest you give yourself a wide margin of error. We picked a five-week window. In addition, each individual must have a Mexican National Park 'passport', which is about \$25 U.S. a year per person, and can be obtained by asking at most marinas in Mexico. These 'passports' are good for all Mexican National Parks, including the Copper Canyon, Turtle Bay, the islands in the Sea of Cortez, and elsewhere, so they are a good value.

"Sr. Narro Flores will make two copies of all your documents, give you a receipt that he has received these copies, and



Since we have no photographs to illustrate the Revillagigedo Islands, we thought we'd run another shot of Kimberly having fun on 'Wanderlust 3'. This should help everyone warm up after the chill they no doubt felt after seeing the photo of Warm Springs Bay.

then send the copies to the CONANP office in La Paz for "review." Approximately two weeks later, he will issue the permits in Cabo San Lucas, and if you're not there, use DHL — currently at their expense — to mail you the permits at an address you will provide. You may also apply for the permits at the CONANP office in La Paz, but if you do, they need to

Your Boatyard in the Heart of Paradise



Large, fenced, secure dry storage area

Tahiti Customs policy has changed!
Foreign Flag vessels can stay on dry storage in our yard for up to 12 months out of 24.



A Subsidiary of
The Moorings Yacht Charter, Ltd.

Our Services |

HAULOUT

- Marine Travelift 25 tons
- Marine railway 120 tons
- Storage in adjustable steel cradles
- Fenced Yard

PAINTING

- Topsides, hull, bottom, varnish
- Brush, roller, spray

MECHANICAL WORK

- Inboard, outboard, diesel, gas
- All brands

REPAIRS

- Electrical repairs
- Refrigeration installation & repair
- Fiberglass & woodwork
- Welding, steel, stainless, aluminum

SAIL LOFT

- Sail repairs, biminis, dodgers, covers

STORE

- International, Pettit, Epiglass, Devoe
- Spares
- Fill U.S. gas cylinders

DO-IT-YOURSELFERS WELCOME!

BoatUS Cooperating Marina



Professional boatyard in the heart of Paradise

Raiatea Carenage will make sure
paradise is everything you expected.

Call, write, or sail in . . . we're here to serve you.

B.P. 1111 Uturoa Raiatea 98 735 Polynésie Française

Tel: (689) 600-545 ~ Fax: (689) 600-546 ~ VHF 68

Web site: <http://www.raiatea.com/carenage> ~ email: raiataecarenage@mail.pf

CHANGES

send all your original documents mentioned above to the office in Cabo San Lucas. Most people will not choose this option, but it can be done that way. The Cabo San Lucas office then returns your originals to La Paz, where the permits are issued.

"Sr. Narro Flores speaks excellent English and was most encouraging and helpful. You will have a pleasant experience when meeting him. He can be found at Calle El Pescado/Camino Viejo a San Jose, Building D, second floor, Col. El Medano, Cabo San Lucas, B.C.S. You can email him at cnarro@conanp.gob.mx or bionarro@gmail.com. Or, you can call him at 624-172-0210 or 624-172-0219. His personal cell phone is 624-147-9104."

The Stolnitzes report they've been joined at the Revillagigedos by Chuck Houlihan and Linda Edeiken of the San Diego-based Allied 39 **Jacaranda**.

"Hello to everyone from Hawaii," write Greg King, Jen and Coco Sanders, and



LATITUDE / NICK

Most of the participants aren't anywhere near this serious 'racing' their boats in the Banderas Bay or Sea of Cortez regattas.

Ducky the dog — the 'Coco-Nuts' aboard the Long Beach-based 65-ft schooner **Cocokai**. "We'll be here for a couple of more month making upgrades to the

schooner before heading south again. We just wanted to wish everyone the best for the new year."

There are still three big cruisers events remaining in Mexico this winter: The 'nothing serious' **Banderas Bay Regatta** for cruisers only, which is based out of Paradise Marina in Nuevo Vallarta. The dates are March 17-21. There is no entry fee. The second event is the revived **Sea of Cortez Sailing Week** out of La Paz starting on April 1. There is no fee for this event either. Both of the first two events are for cruisers who really love to sail. Finally, there's **Loreto Fest**, from April 30 to May

3. Although this fundraiser at Puerto Escondido is more about music than sailing, many cruisers attend. There is no entry fee.

If you are lucky enough to be out cruising these days — on any ocean — we'd love to hear from you. So drop us an email and a couple of your best high res photos.

Your secret paradise...

in
Nicaragua

Located in a beautiful sheltered lagoon on the north Pacific coast of Nicaragua, Marina Puesta del Sol is your premier cruising destination in Central America.

Marina Puesta del Sol
RESORT

Aserradores, Nicaragua ♦ 011 (from US and Canada) 505-880-0019
mpuestadelsol@yahoo.com ♦ www.marinapuestadelsol.com ♦ USA 408-588-0017

MARINA REAL

SAN CARLOS, SONORA, MEXICO

IN THE SEA OF CORTEZ
Located on the Mexican mainland near Guaymas and San Carlos, 265 miles south of Nogales, Arizona.

- 350 slip marina • 20 & 30 amps electrical service
- 24-hour security patrol
- Fuel dock with gasoline/diesel
- Restrooms & showers
- Web email • Fax/copy service
- Port entry clearance
- Book exchange • Video loan library
- Ice & bottled water
- Wet storage for summer months (low prices)

Now Offering:
Haulouts, Dry Storage & Service Yard

marina Real

Phone/fax 011-52-622-2270011
Call on VHF #16 when in area
email: marinareal@prodigy.net.mx
Visit our website:
www.marinareal.bravehost.com

OPEQUIMAR

MARINE CENTER CENTRO MARINO

10% OFF
ON LAY DAY
during
January/February
2009

**88-ton (max)
Travelift!**
Length to 100'
Width to 23'

Puerto Vallarta, Jalisco, Mexico
Paseo de la Marina Sur #214 • Marina Vallarta, 48354
Tel: 011 52 (322) 221 1800 Fax: 011 52 (322) 221 1978
email: info@opequimar.com



Visit Our
Yacht Club!

Opequimar Yacht Club

First Class • Full Service

On site dining, Internet, socials

BOAT SALES
NEW & USED BROKERAGE
www.opequimar.com

West Marine
We make boating more fun!

SIMRAD
A KONGSBERG Company

PETTIT
marine paint

Come to Mexico,
Enjoy the Mexican Riviera,
Repair your boat at
OPEQUIMAR



RICHARDSON BAY MARINA

formerly Kappas Marina

MODERN FACILITIES IN A WELL-PROTECTED HARBOR

**Concrete
Dock System**

**Well Maintained
Facilities**

**Beautiful
Surroundings**

- DEEP WATER BERTHS:
BASIN AND CHANNEL
DREDGED
- CARD KEY SECURITY SYSTEM
- DOCK CARTS
- PUMP OUT STATION
- AMPLE PARKING
- CLEAN SHOWER AND
TOILET FACILITIES
- WITHIN WALKING
DISTANCE: MARKET/DELI,
LAUNDROMAT,
RESTAURANT
- AT EACH BERTH:
LARGE STORAGE BOX,
METERED ELECTRICITY,
PHONE HOOKUPS, WATER

BERTH YOUR BOAT IN SAUSALITO

Phone 415 • 332 • 5510

100 Gate Six Road, Sausalito • Fax (415) 332-5812



LIFELINE
...the heart of your system

Crafted for quality in the U.S.A.

MARINE BATTERIES

The original AGM manufacturers for the Marine and RV Industry

Sealed, Pressure Relief Safety Valves
Operates in any orientation without leaking. Maintenance-free; never requires water additions.

Lifting Handles
Easier handling, carrying & installation.

Copper Alloy Terminals
Provides low resistance electrical connection (copper-to-copper), non-corrosive. Increased environmental protection & personal safety — no exposed lead.

Reinforced Copolymer Polypropylene Container & Cover
High impact resistance and resists bulging even under severe overcharge and temperature.

Absorbent Glass Mat (AGM) Separator
Custom designed and manufactured to provide superior wicking characteristics for electrolyte retention.

Polyethylene Envelope
Eliminates internal shorts caused by shock, vibration & dendrite growth.

Thick Plates and High Density Oxide Paste Materials
Insures long life, excellent cycling capability.

Intercell Connections
Massive "over-the-partition" weld increases the weld strength & provides low resistance connection path.

Cover-To-Container Seal
Strong, epoxied tongue & groove cover/container seal will not separate even under extreme temperature & pressure changes or vibration.

To learn more about Lifeline Batteries contact us or visit our web site at:

LIFELINE BATTERIES, INC.
955 Todd Ave.,
Azusa, CA 91702
800-527-3224
<http://www.lifelinebatteries.com>

Lifeline, a pioneer in AGM technology was originally developed in 1985 for military aircraft. Lifeline series of maintenance free deep cycle batteries that has been the leading AGM battery in the Marine and Motor Coach Industry for the past 15 years.

Please read before submitting ad

CLASSIFIEDS

1. Write your ad. Describe what you're selling. Indicate category. Don't forget price and contact info.

Be neat. We aren't responsible for errors due to illegible writing or unclear meaning. We make final placement determination.

2. Count the words. Anything with a space before and after counts as one word (eg, phone number, email address, price). We'll spell-check, edit and abbreviate, as necessary.

3. Mail your ad. Enclose check or money order, or deliver to our office with cash, or ...

Post your ad safely online with Visa, MasterCard or AmEx at: www.latitude38.com

Personal Ads

1-40 Words: \$40
41-80 Words: \$65
81-120 Words: \$90
Photo \$30

• Personal Advertising Only •
No business or promo ads except Non-Profit, Job Op, Business Op

Business Ads

\$70 for 40 Words Max
• All promotional advertising •
1 boat per broker per issue
Camera-ready art OK
No photos or reversals
No Extra Bold type
Not to exceed 12 pt font
Artwork subject to editor approval.

'Trying to Locate' Ads

Searching for People: \$10 for 20 Words Max

All ads will be set to fit *Latitude 38* standard.
Re-Run Ads: Same price, Same deadline.

Mail (or bring) to: *Latitude 38*
Attn: Classified Dept

15 Locust Ave, Mill Valley, CA 94941

Questions?: (415) 383-8200, ext 104 • class@latitude38.com

DEADLINE

is always the

18th at 5 pm

of the month prior to publication.

Due to our short lead time, deadlines are *very strict* and include weekends & holidays.

- No ads without payments
- No billing arrangements
- No ads accepted by phone or fax
- No verification of receipt
- We reserve the right to refuse poor quality photos or illegible ads.

SATISFIED CUSTOMERS: We received this email the other day: "Valiant 40 SOLD - *Latitude 38* was out less than a week, and my boat sold for CASH. Thank You!" Even with this challenging economy, you can still depend on *Latitude*. Our advertisers are getting more creative. Give it some thought and see how exposure to our audience can mean money for you. A mere \$40 ad can turn all that spare sailing gear in your garage into cash. An ad in 'Partnerships' will find Bay Area sailors who would love to share your boat expenses in exchange for time on the water. Or maybe now's the time to trade your condo for a cruising sailboat and change your life. Think of all the possibilities!

SANTANA 22, 1969 CLASSIC. Newer mast and standing rigging. Set up to race with newer sails. Docked at Vallejo Marina, E91, last 2 years waiting for new attentive owner/racer. Make me an offer you can't refuse. (707) 845-8295 or (707) 599-6892.

J/24, NIXON WAS COOL. Multi-season SF Bay fleet champion. Fast, ready-to-go one-design racer, with dual-axle trailer. New North San Diego sails, TackTick compass, new standing rigging and boom. For more details see: <<http://www.gybetheljib.com/nixon>> Email: chet_chauhan@yahoo.com or call (415) 595-2566.



CAL 20, 1966. On 4-wheel trailer. Merc 6-hp. Sleeps 4. Roller furling jib, Porta-Potti, fully equipped and in good shape. GPS, VHF included. Dry sailed at Channel Islands Harbor, Oxnard. \$1,750. Call Jeff (818) 889-0898.

J/27, 1986. Sleek, stylish performance boat for club racing, daysailing. Excellent condition. Balanced, nimble, points high, PHRF 120. Lots of sails. \$17,500/obo. In San Rafael. (415) 456-2397 or portobello40@earthlink.net for spec sheet/photos.



ANTRIM 27, LUNA. Excellent condition. Racing/cruising. Fun and fast sailing. Many sails. Two masts. Trailer. Currently berthed at SFYC, Belvedere. \$38,000. For details email: trig@gotoeurostyle.com or call (415) 613-2550.

1987 BRISTOL CHANNEL CUTTER. Sam L. Morse factory-finished standard layout. Radar, AIS, ICOM SSB, Pactor modem, liferaft, Espar heater, EPIRB, solar, windvane, generator, dinghy with Yamaha outboard. \$169,000. See website: <<http://www.johnpurins.net/Adventure.html>> or email: johnpurins@comcast.net or call (650) 430-0731.

30-FT WOODEN ONE-DESIGN BIRD. Outstanding condition. Good race record. Nothing sails like a Bird. Sausalito berth available. \$15,000. (415) 302-7490.

DINGHIES, LIFERAFTS AND ROWBOATS

TINKER SAILING TRAMP 9-FT inflatable, yellow, full sailing kit, stowage cover, excellent condition, want to trade for Tinker Sailing Traveller, ideally yellow with performance sailing kit. Cash to equalize value. Email: Tinker@Ricks-Cafe.net.

8-FT HARD DINGHY. Solid fiberglass, lapstrake hull, \$500. Located in Sausalito. Call (415) 425-6420.

24 FEET & UNDER

J/24, 1978 with trailer and motor, almost new 150, many new lines, loaded. Reduced price of \$3,900 or any best offer. Call Charlie (831) 373-1489.



INTERNATIONAL 505s. Parker, Rondar, Moore and Lanaverre. Take your pick, full race. Ron Moore boat, new mast and boom, like-new sails, \$7,500. Parker ready to race, \$5,500. Rondar with good trailer and sails, \$3,500. Two more project boats, \$2,500 and \$1,500. Photos and gear lists available. Ray in Burson. No internet please. Fax or phone: (209) 772-9695.

25 TO 28 FEET

1977 FACTORY FINISHED Sam L. Morse Bristol Channel Cutter 28. A fabulous boat, loaded, lovingly maintained and in good shape with tons of spares. In SF Bay Area. \$110,000. For details see: <<http://sites.dicarpegna@sbcglobal.net>> Email: dicarpegna@sbcglobal.net.

LASER 28, BRUCE FARR design, one set of Dole sails, some extras. Inboard diesel. Great racer/cruiser. Dry stored on trailer. \$11,500. Call Tom (510) 865-6641.

O'DAY 25 SWING KEEL, 1976. Well kept and updated. Hauled 4/08, new rigging 9/07, electrical upgrades. 2007 9.8 Nissan longshaft, low hours. Custom interior very comfy. Hank-on 85% and 100%, single-reef main, all good. Transferable slip in Sausalito. \$4,000. Email: oday1022@yahoo.com.

29 TO 31 FEET

Latitude 38 eBooks

WORLDWIDE ~ JUST \$18/yr

www.latitude38.com

VOLVO PENTA

Specialist Dealer Since 1980

ESKELUND MARINE • (510) 523-7670

1913 Clement Ave • Alameda Marina • Bldg 13 at Pier 2



STARBOARD YACHT DELIVERIES

Over 50,000 sea miles • Pacific, Caribbean, Atlantic
USCG Master 100 GT STCW • Power & Sail

Rick Whiting • (415) 740-2924 • captain_rick@sbcglobal.net



NOR-CAL COMPASS ADJUSTING

Magneuto™ System Exclusively

Boat Remains in Berth • Eliminates Deviation
Authorized Compass Repair • All Major Brands

Hal McCormack • Phone/Fax: (415) 892-7177

CHART SAVINGS UP TO 76%

HIGH DEFINITION PRINTS • 256 INCREDIBLE SHADES!

Worldwide • Sample Chart \$5.95 • Affordable E-Chart back-ups
Bellingham Chart Printers Division, TIDES END LTD., PO Box 397L, Shaw Island, WA 98286
800-643-3900 • fax: 360-468-3939 • www.tidesend.com • sales@tidesend.com

PEARSON 30, 1975. 10-hp diesel, knotmeter, depthfinder, lifelines, wheel steering with compass, Barents, 4 sails, whisker pole, emergency tiller, 2 anchors, alcohol stove, standing headroom, sleeps 5-6. Located on Estuary. \$10,000. Call (530) 676-8507.

WYLIECAT 30, 1999. *Triumph.* Rare opportunity to own one of these beautiful cat-rigged, easy to sail, lively boats. Immaculate condition. Yanmar diesel inboard. New mainsail. 2005 survey available. Currently lying in Puget Sound. \$82,000. (510) 758-5265 or JSkinner37@aol.com.



NOW'S YOUR BEST CHANCE TO OWN a winning Knarr. Compete in San Francisco Bay's best racing fleet. *Peerless* is a fiberglass yacht that won the Season Championship in 2001 and has been a consistent strong finisher over the last 10 years. Ready to race, City Front slip negotiable. Priced to sell at \$25,000. Call Larry Drew (415) 640-3978.

CAL 29, BOOGALOO. Strong race history, very competitive. Full race sail inventory, good condition, with 3 spinnakers. Rebuilt, regularly-serviced Atomic 4 engine, starts right up and runs smoothly. Full standing headroom in interior. Nice interior varnish work. Sleeps 6. \$9,000. (415) 435-4498.



PEARSON 31, 1978. Beautiful plastic classic. Volvo diesel. Fast and stable, perfect for Bay and family. New last 2 years: Hogin sails, running rigging, upholstery, lifelines, head, batteries, wiring, exhaust. Located Brickyard Cove. \$14,750. David (916) 747-3577.

J/92, RAGTIME. 30-FT Singlehanded TransPac vet. Near-new North 3DLs, many other recent sails. Fresh racing bottom. Yanmar diesel. Excellent condition, survey available. Turnkey for Bay/coastal races or performance daysailing. \$54,900/firm. (925) 969-9404 ext 26 or BobsailsSF@aol.com.



CHEOY LEE 31 OFFSHORE CLASSIC. Fiberglass, rebuilt MD2 diesel, new Awlgrip, interior cushions. Needs TLC. \$11,500. Marina del Rey, CA. (310) 305-7207 or donklein@gmail.com.

32 TO 35 FEET

SAN JUAN 34, 1984. Very few built. Fast cruiser, excellent condition. 6' headroom, galley, sleeps six, rod rigging. Roller furling headsail, 150% genoa, main, working jib, in good condition. 3GMD Yanmar, Achilles dinghy, large bimini. \$41,000. Call (510) 420-8956 or nino@access-print.com.

J/BOATS J/100, 2005. Fast, fun, ultimate singlehander. Extensively equipped with B&G instruments/autopilot. Furuno GPS, electric halyard winch, jib boom. Thoughtfully and thoroughly rigged for easy handling. Meticulously maintained. \$124,900. Contact Steve for detailed specs and pictures: (415) 931-7983 or SteveR.sf@gmail.com.



HUNTER 33, 2004. Excellent condition. Glen Henderson design. Absolutely the most custom, cruise-ready 33 on the planet. All top-quality hardware and installation. Too many options, custom products and systems to list. Handles easily and is very spacious and comfortable. Located in Puerto Escondido, Baja, Mexico (no tax delivery). On private anchor system in harbor at \$30/month rent. Will deliver to US location. Divorce forces sale. \$112,500, reduced to \$88,765. (415) 992-8057 or <www.myspace.com/carlosmango>

1969 BRISTOL 33 PLASTIC CLASSIC. Halsey Herreshoff design. Great Bay sailer, liveaboard. Electric auxiliary power, 48-volt system, no fossil fuel required. Berthed in Brisbane. \$17,000. Email cwbylsr@comcast.net for details.

OFFSHORE ONE DESIGN 34, 1980. Doug Peterson design, Jeremy Rodgers construction. Excellent condition. Carefully maintained and improved with many recent upgrades. Exceptional value at \$39,000. Call (415) 388-2582 or (415) 552-0860 for more info. Photos and details at: <http://yacht.milagro.googlepages.com/home>

PEARSON ALBERG 35, 1966. Sound boat. Good sail inventory. Great headroom. Yanmar diesel needs to be installed. Holding tank needs to be plumbed. Located in Berkeley Marina. \$12,700. (510) 332-9624.

SCANDIA 34 CUTTER. Immaculate and cruise ready. Under 300 hours on Yanmar. Hard dinghy with oars and outboard. Beautiful interior. New propane stove. New Dickinson heater. Asking \$50,000. Call (510) 885-0685 or email: jwilliam94002@yahoo.com for pictures.



WESTSAIL 32, 1977. Very clean and well maintained. Outfitted for cruising. Excellent liveaboard. 80 gal. fuel. 80 gal. water. Dual Racors. Radar. Aries windvane. Inflatable dinghy with outboard. Documented. Located San Rafael. \$48,500. Call (415) 729-6127.

WAUQUIEZ PRETORIAN 35, 1985. Located in La Paz, Baja, Mexico. A beautiful example of this excellent-sailing, comfortable, well-built cruising sloop. Many upgrades. In immaculate condition. Ready to cruise wherever your imagination takes you \$82,500. For particulars see <www.mazmarine.com> or email: ggoodski67@yahoo.com.

RANGER 33 SLOOP, 1978. Full set Pineapple sails, including stormsail. Monitor windvane, lines led to cockpit for singlehanded/easy reefing. 3 anchors, 300' chain, 300' 5/16" rode. Charts: CA to Mexico, EPIRB. New dodger. Perfect bottom. \$19,400/obo. La Paz, Baja. (415) 902-1061.

ISLANDER 34 SLOOP. Classic fiberglass cruiser. All systems, interior and exterior, restored to new, including Universal diesel, Autohelm instruments, new galley and head, stainless steel range and water heater. \$11,000. Call Mike (209) 613-9331 or westsideassociates@yahoo.com.

J/105 HULL #196, 1998. *Risk.* 4th, 6th place overall in SF Fleet in 2007, 2006. Perfect race-ready condition, minimum weight, new bottom in 2008, B&G instruments with 2 maxi displays on mast, latest tricked-out sheets and halyards, spare set of cruising sheets, halyards and sails. Engine in excellent condition and regularly maintained. One regatta on brand-new North main and kite. Too many sails to list. Price \$105,000. Call Jason (415) 297-0794 or jfwoodley@yahoo.com for details.

J/32, 1997. Great racer/cruiser. Great condition. Fast, fun, comfortable, easy to singlehand. Racing and working sails: 2 mains, 4 jibs, 3 spinnakers, spinnaker pole. Yanmar diesel. Very well equipped. \$109,000/obo. Pictures and details: <www.pbert.com/j32> (415) 497-0795 or hollandier242000@yahoo.com.

NOR'WEST 33. Classic bluewater racer/cruiser featured in November, 2006 *Cruising World Classic Plastics*. 1978, hull #6. Cruising ready. Full complement of sails, wind generator, solar panel, new bimini and interior upholstery, radar, GPS, Monitor self-steering vane, autopilot, new standing rigging and Harken Mk IV roller furler at headsail. LectraSan waste treatment system, all new head plumbing, bottom paint, new multi-stage battery charger. Most systems replaced in past 10 years. 2006 survey available. Currently berthed in San Diego. Asking \$55,000. Call (510) 301-3431 or email: sailskye@pocketmail.com.

36 TO 39 FEET

JEANNEAU 36, 1997. Very well maintained. Electric anchor windlass, dodger, refrigerator/freezer, GPS, chartplotter, autopilot, CD player, VHF, B&G instruments, depth/knot/wind, dinghy with 2-hp Johnson. \$95,000. To view call Roy (510) 523-4081 or Brian (209) 722-2068 or coolswick@aol.com.

ISLANDER 36, 1977. Perkins 4-108, new rigging 2002, 2 self-tailing Harken 44s, 2 self-tailing Barlow 25s. Dodger, covers, holding tank, macerator, propane stove/oven, radar, chartplotter, VHF, bowroller, 2 anchors/chain and rode, carpets/curtains, Avon/ob. Alameda Marina #204. \$55,000/obo or will trade up for larger boat with aft cabin, trade plus cash. Arnie (415) 999-6751 (cell) or (415) 383-9180 (hm) or email: arnoldgallegos@comcast.net.

CHEOY LEE CLIPPER 36 KETCH in San Diego. Not a 'yacht' but without question the best value in a solid cruiser on the market. Just add food, fuel, water and go. \$36,000. For more info email: FrConrad@gmail.com.

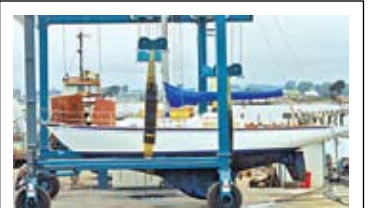

38-FT SLOOP, 1970. Canadian-built Hughes. Asking \$24,000/obo. Sails well, has new diesel inboard engine. Located in Monterey, CA. (831) 915-4984.

CATALINA 36, 1985. Universal diesel, custom-built aluminum gas tank. Great condition. Very clean interior with plenty of comfort. Refrigerator, shower, GPS, radio, lots of extras. Comes with new paint. Must see. Pics at: <http://www.flickr.com/photos/48403161@N00/sets/72157606203417726/> \$50,000. Call (510) 812-2032 or w.designbuild@yahoo.com.

SMALL AD, SMALL PRICES • RIGGING ONLY

Standing and running rigging, life lines, furling gear, winches, line, windlasses, travelers, wire and terminals, blocks, vangs, and much more.

~ ~ ~ Problem solving and discount mail order are our specialties ~ ~ ~
www.riggingonly.com • (508) 992-0434 • email: sail@riggingonly.com

BOAT • LETTERING

alphaboatsue@aol.com • (510) 599-1197 • www.alphaboatgraphics.com

Creative and durable lettering and artwork for your boat

FREE FIBERGLASS REPAIR MANUAL

Repair your fiberglass boat confidently with WEST SYSTEM® Brand Epoxy
We're offering *Latitude 38* readers a free comprehensive 85-pg
Fiberglass Boat Repair & Maintenance manual • \$4.85 value
To get yours, email: FreeManual-L38@westsystem.com



COMPLETE MARINE WOODWORK

Design / Restoration • Expert European Craftsmanship • Interior / Exterior
Repairs / Maintenance • Marine Windows & Frame Replacement
Wood & Dry Rot Repairs • Varnish Work • Marine Painting
References Available • Reasonable Rates • Call (415) 331-6718

Custom Canvas & Interiors



The Gianola Family has been designing and fabricating custom canvas and interiors since 1969. Gianola & Sons offers you the best in quality, more choices, and personal service.



360 Gate 5 Road
Sausalito, CA 94965
(415) 332-3339
www.gianolacanvas.com

1955 FARALLONE 38 CLIPPER. Total restoration 2007. Good sails and rigging, heater, engine runs great. Over \$80,000 invested. Financial downturn means BOAT must go. First reasonable offer. Pictures on Yachtworld. In San Diego, private slip available. (619) 507-6129.

HUNTER VISION 36, 1994. This is an absolutely beautiful boat. Hardly used, always maintained. Too many upgrades to list, I will be happy to email or fax the spec sheet and pics. The boat is in like new condition. Berthed at Marina Village in Alameda, CA. We are moving inland and need to find a good home for our pampered boat. NADA value \$65,250 – \$89,550. No reasonable offer refused, really. (925) 577-8900 or avers@mac.com.

BEAUTIFUL BLUEWATER VAGABOND 39. Located in tropical Puerto Lucia, Ecuador. Gateway to the Galapagos, Panama and South Pacific. Check her out at: <www.sailboatunity.com> Comes ready to cruise, everything except my clothes stays. Asking \$106,000. Email: vanjerm@yahoo.com or 011 (593) 8428-8098.

PASSPORT 37, 1986. Great condition, ready to cruise. New last 4 years: Universal diesel, MaxProp, windlass, mainsail, watermaker, 335w solar panels, 660AH batteries, spade anchor, windvane, roller furler, upper rigging, SSB antennae, lifelines, etc. Friday Harbor. \$125,000. (208) 724-0888 or passport37sailboat@yahoo.com.

STEPHENS 38 FARALLONE CLIPPER sloop. Offered for sale is a classic wooden sloop built for the sailing conditions of San Francisco Bay. Launched in 1957, the boat has good sails, a strong Universal diesel, and is a joy to sail. For more information visit: <http://www.yachtworld.com/boats/1957/Stephens-Farallone-Clipper-Sloop-2015369/Berkeley/CA/United-States> or call (925) 876-9183.

40 TO 50 FEET



TARTAN 4400, 2004. Hull #1 of Tartan's newest deck salon. Electric winches, Vacuflush heads, full batten main, roller genoa, cruising spinnaker. Espar central heat, bow thruster. Kato davits, Caribe inflatable. Only 170 hours on diesel engine. New condition. \$475,000. (530) 318-0730 or amgjohn@sbcglobal.net.

VALIANT 42, NEVER USED. Never in salt water. Quantum sails, ProFurl on jib, autopilot, microwave, Westerbeke diesel. Boat is as new, location Valiant factory in Texas. \$295,000. Call Dick May (480) 513-7136 or boatseller@aol.com.



LIVE YOUR DREAM. Sail the far reaches. *Lone Star* is waiting to take you on your dream cruise – Mexico, Panama, Tahiti, Bora Bora and beyond. Sail fast, safe and in comfort. This cruiser will delight your partner. Here is a turnkey cruising boat built for domestic tranquility. Only \$89,950. We will consider a trade for a trawler, houseboat or motor yacht of equal value in the SF Bay Area or one that can be trucked to the Bay Area. Email: slonestar@yahoo.com.

BENETEAU 40, 1995. Cruise the Eastern Caribbean this season. Fully solar and wind powered. Escape to paradise on a simple, fast, fun and comfortable Caribbean boat. \$95,000. See: <www.accidentalcruiser.com> then email: lance@accidentalcruiser.com.



VALIANT 40, 1981. \$90,000. New batteries, charger, inverter, stereo/speakers in/out. New Raymarine chartplotter, depth, VHF. Diesel heater. 3-burner stove/oven. 89-gal fuel. 150 water. 11 hot water. 50-hp Westerbeke. Reefer makes ice. Visit: <www.valiant40.webs.com> Email: pir8mo@hotmail.com.

2007 CLASS 40 (POGO) in Long Beach. North sails: code 0, 2A, 5A. Partnership in a LLC for sale. Fully optimized for Mexican Races and TransPac with crew of 2 to 6. <www.pogostuctures.com/?m=4&s=1&l=en> \$150,000/obo. (562) 243-7757 or bernard@gantes.com.

40-FT KING CHOI KETCH, 1973. Ferrocement sailboat. Great for cruising or liveaboard. 3-year-old sails. Volvo diesel engine. Located in Dana Point, CA. Good condition, must sell: \$9,000. Call (949) 497-7110 or email: cecilolorlania@yahoo.com.



MARINE ENGINE CO.

Complete Engine Services • Gas & Diesel
30 Years Experience • Reasonable Rates
Tune-Ups • Oil Changes • Engine Rebuilding, etc.
(415) 332-0455

WOODRUM MARINE

Specializing in custom interior cabinetry, tables, cabinets, countertops, cabinsoles. For power or sail.

CARPENTRY

Mobile cabinet shop
Contact Lon Woodrum at:
415-420-5970
www.woodrummarine.com



1,000 Used Sails
Listed at
minneysyachtsurplus.com

We Buy Good Used Sails
and Marine Equipment

MINNEY'S YACHT SURPLUS

1500 Newport Bl., Costa Mesa, CA
949-548-4192 • minneys@aol.com

"We keep boating affordable!"

MARINE OUTBOARD COMPANY

Johnson
Evinrude
Mercury
Nissan



Tohatsu
Mariner
Honda
Yamaha

(415) 332-8020

Our certified technicians have repaired, rebuilt, repowered and serviced outboards and boats since 1990 for less than anywhere else in the Bay Area. How? Less overhead... All repairs and parts come with a 1-year warranty; 3-year warranty on new Nissan engines.

35 Libertyship Way • Sausalito, CA 94965

HUNTER 41 SLOOP, 2004. Extremely well maintained. Photos and specs available to serious inquiries. Asking only \$165,000. Potential for end-tie slip transfer with purchase. San Diego Bay. Call (760) 845-1421.

HYLAS 44, 1989. If you are looking for a proven cruising boat, check this one. Too much equipment to list. Two-boat owner must sell. \$170,000/obo. (707) 253-9147 or caladesi@pacbell.net for specs and pictures.



HANS CHRISTIAN 44 PILOTHOUSE motorsailer, 1981. A great cruising boat for all locales and ready to go. Excellent condition. Currently in San Diego Bay. More photos and info: <www.geocities.com/svwwandrinstar> or (248) 376-6672.

1987 SLOCUM 43 PILOTHOUSE. \$159,000. This is an offshore passage-maker of very high quality with unique features that will make passagemaking more comfortable. It has a bright and cheerful layout, abundant storage and a design that will stand out through time. This is not a compromise sailing vessel. If it suits your needs, few will compare. Great for kids and entertaining. This vessel will be sold to the knowledgeable sailor who knows what they want. Alameda. Robert (925) 484-4629.



BENETEAU 405, 1987. Terrific club racer, or cruise anywhere in the world. Professionally maintained, new bottom. North 3DL sails and spinnakers. Main and #1 less than a year old. Spinnaker just over 1 year. Three mainsails, three #1s, one #2, two #3s, 2 spinnakers, more. Two heads, hot water, shower, fridge unit in icebox, 2-burner stove with oven. Incredibly well-built racer/cruiser. Farr design, great race record at local level, built to be cruised anywhere in the open water. Sleeps 6 comfortably. Don't want to be two-boat owner, so terrific opportunity for someone who wants to race locally and/or make cruising trips to the islands or elsewhere. \$91,500. Orange County. (949) 290-4158 or anamport2002@yahoo.com.



ANACAPA CHALLENGER 42. Center cockpit. Heavy-built full-keel cruiser. Real queen-sized mattress in master cabin. Sleeps 6, fully enclosed cockpit, 12' dinghy with 6-hp ob. Large gourmet galley, Iso-temp refrigerator/freezer, Iso-therm water heater, Princess oven/stove, all new. Quantum jib, main, spinnaker. Redundant electronics: 3 VHF's, ICOM SSB with Pactor III email, upgraded. New Furuno DGPS antenna. New Nobeltec WAAS antenna. 235 gals fuel. Primary fuel tank completely cleaned, resealed from inside. New FilterBoss dual fuel filter and polishing system. Hydraulic windlass, new chain, 3 anchors. 5 new Lewmar hatches, new Bomar portlights throughout. No leaks. Solar, wind, lifeboat, kayak, plus spares. 100-hp SD33 engine. New cylinder head and ss muffler. New Nobeltec AIS system. \$85,000. Call (916) 880-8896 or jhardi95616@gmail.com.

PETERSON 44 CENTER-COCKPIT cutter, 1977. Two staterooms, two heads. New Yanmar, LP, fuel tanks. Robertson autopilot, radar, dinghy, outboard. \$109,000. San Carlos, Mexico. For complete list and photos: (520) 742-2727 or (520) 235-6695 or svubetcha@aol.com.

MULTIHULLS

33-FT CROWTHER 10M CATAMARAN. Ex-race boat, now dependable offshore cruising boat. Factory-built foam core fiberglass. Was \$100k, now \$75,000. On hard in Panama. Cruised for past 10 years in Central America. Email: chewbacca@sfsailing.com for complete information and photos.



1973 HIRONELLE CATAMARAN. Fiberglass. safe cruising. 15' ed ly e man@



2008 LAGOON 420 CATAMARAN. Avanga is loaded and beautiful. Recently placed in charter fleet, TMM Belize. Light use. No long-term contract. Save \$200k versus new. \$395,000/firm. lagoon420@live.com.



WILDCAT 350, 2000. *Out of Africa.* 35' x 21' beam, Doyle sails, spinnaker, radar, 20-hp Volvo sail drives, folding props, Spectra watermaker. Boat loves Mexico. 4 staterooms. \$169,000. (916) 777-4756, or (916) 716-0669 or email: rich.cavanagh@yahoo.com.



37-FT CSK FACTORY-BUILT fiberglass world cruising catamaran. Twin diesels with MaxProps, dual steering, daggerboards, anchors, windlass. Galley up in salon full headroom with beautiful teak interior. Safe great sailing boat, great condition. \$45,000/obo. (831) 475-6869.

POWER & HOUSEBOATS

43.5-FT LABELLE TRAWLER. Sausalito outstanding view berth. Volvo diesels, 500 hours, 7.5 Onan. Roomy glass-enclosed sundeck. Full canvas. Large custom galley. Master with walkaround queen, tub + comfortable guest stateroom with large bed, head. Excellent workmanship/condition. May finance, rent or trade. (415) 331-5251.



PRICE REDUCED. 30-FT WILLARD Vega Searcher. Excellent little ship for 2, good for 4. Super condition in/out. All systems in excellent condition. Full electronics. All safety gear, full head, 100 gals fuel, 100 gals water. See to appreciate. Call (650) 207-6898 or (650) 851-3402.



65-FT WOOD CLASSIC, 1939. Heavy built ex-trawler. GMC 12V-71, 21-kw generator. Full electronics. Lots of equipment. Ready to go. Would make great conversion. More pics/details: ancona@mcn.org. Will consider any reasonable offer. Call (707) 964-5423.



32-FT CLASSIC MONTEREY. Totally restored Monterey fishing boat, converted to day boat, sportfisher or Bay cruiser. All woodwork has been done. New fuel tanks, hydraulic steering, tinted glass, etc. GMC 2-71 diesel engine. Needs to be finished, such as controls, wiring, exhaust and finishing touches. Must be seen to be appreciated. Will consider any reasonable offer. Pics/details: (707) 964-5423 or ancona@mcn.org.

PARTNERSHIPS

50% SAILBOAT PARTNERSHIP. Available in 2004 mint condition J/109, active SF racer/cruiser. 1st in SF Bay J/109 Division, 3rd in PHRF Party Circuit 2008. Also great family cruiser in Delta and SF Bay. Interested parties only, contact Soren: (415) 717-3664 or ahoys@earthlink.net.

ISLANDER 36 1/4 OR 1/2 EQUITY share. South Beach Harbor slip. Perkins 4-108 diesel, low hours. New mast and rod rigging, roller furling. Recently hauled and painted. Call Frank (650) 964-8901.

CATALINA 380, 2001. 1/4 equity share. \$12,000, \$650/month includes all expenses. Sausalito Yacht Harbor. Full electronics, dodger, in-mast furling, spinnaker. Zodiac with outboard, much more. See: <http://picasaweb.google.com/sailbarca/2001Catalina380> Email: sailbarca@gmail.com.

EXPRESS 34, 1987. Perfect for racing, daysailing, and weekend cruising. Looking for one, maybe two, equity partners. Very good condition. Lots of sails. Berthed in Alameda, but negotiable. Survey March 2008. Valued at \$62,000. Call John (510) 366-1476 or j_tuma@comcast.net.

MULTIHULL YACHT DESIGNER • MARINE SURVEYOR

John R. Marples, CMS • Certified, National Association of Marine Surveyors
Multihull Design Specialist • Pleasure and Commercial
Design office for Jim Brown Searunner, Seaclipper & Constant Camber Multihulls
www.searunner.com • (707) 343-1378 • marplesmarine@comcast.net



Sea Wolf MARINE SERVICES

Underwater Yacht Maintenance
Honest • Dependable • Affordable

<www.1800seawolf.com> • (800) Sea-Wolf (732-9653)



Fractional Sailing at South Beach in SF

Catalina 34 • \$575/month!
Catalina 350 • \$695/month!

Call (510) 499-9463
www.windpath.com

VOLPAR, Inc.

(408) 986-0848 • (800) 258-4545
Parts / Service • Penta Only
10am-7pm PST every day including Sat-Sun
email: Volpar@Volpar.com





PRIME FABRICATION
Marine Hardware and Custom Metal Fabrication

- Stainless Anchors - Plow, Fluke, Claw & Ace
- Table Pedestals • Flopper Stoppers
- Helm Seats • Handrails

Ph 949.496.1348
 Fax 949.496.1341
 www.primefabrication.com
 33081 Calle Perfecto, Suite B
 San Juan Capistrano CA 92675

DONATE YOUR VESSEL



- Donate your boat or equipment for a tax deduction
- Learn about our For Sale by Owner program plus tax deduction
- Quality used boats for sale
- Topsides cleaning service, \$2.00/foot

Fundraiser for Ship 65 Sea Scouts and Historic Boat Restorations

650-380-5535



AMERICAN BATTERY
 SERVICE FOR THE DISTANCE
 ...the heart of your system®

Available at the following local marine chandleries and service distributors:

ALAMEDA	MARTINEZ
• Alameda Prop & Machine	• Diablo Marine
• Fortman Marina Store	OAKLAND
• The Boatyard at Grand Marina	• Golden State Diesel
• Star Marine	• Outboard Motor Shop
• Svendsen's Chandlery	OAKLEY
BENICIA	• Big Break Marina
• Cruising Seas Services	RICHMOND
	• Bay Marine

AMERICAN BATTERY • Hayward, CA • (510) 259-1150

STAINLESS STEEL



Strength, Quality and Dependability... plus a Lifetime Warranty!

Stainless Steel Marine Hardware, Rigging & Fittings at Reasonable Prices

See our complete catalog and order on the Web:

www.BOSUNSUPPLIES.com

Or call toll-free for catalog and to order
(888) 433-3484



SOUTH OF THE BORDER

CONDO RENTALS NEAR VALLARTA yacht club. Two adjacent condos overlooking Paradise Village Marina. Each 2 br, 2 bath with Jacuzzi, pool and amenities. Access to Sports & Beach Club. Rent one or both. Call (925) 208-1601 or 011-52 (322) 297-7559 or nwardmoore@gmail.com.

SAN CARLOS MOORING for lease or sale. Prime location in middle of bay. Lease to purchase for \$100 a month or purchase to own. Make an offer. Contact: amvoyage@aol.com.

BANDERAS BAY BEACHFRONT VILLA rental. Between Bucerias and La Cruz in beautiful Punta Esmeralda Community, by private owner. 3 bedrooms, full amenities. For details see: <http://tinyurl.com/8v6w6l> or contact owner by email: tomsailor@gmail.com.

PLAN YOUR MEXICAN GETAWAY NOW at the brand-new, gorgeous Cielo Y Mar condos. Located in Punta Mita, 35 minutes from Puerto Vallarta, available to rent from private owner. Right on the beach, 10 feet from the water, they offer spectacular views of ocean and mountains, the biggest infinity pool in the area, an endless beach, great advanced and beginning surf breaks, great fishing, tremendous views of whales, bird life and the islands. While uncrowded and tranquil, it's just a five-minute walk to several waterfront restaurants. Choose from a spacious and beautifully furnished one or three-bedroom unit, or an amazing two-story penthouse with lovely shade trellis on the top floor. See details: <www.puntamitabeachfrontcondos.com> To reserve, call (415) 599-5012.

TRADE

2008 LEXUS ES350. Original owner, 14k miles, full warranty, black-on-black. Looking to trade (approx. value \$34k) for a cruising sailboat in the 36- to 40-ft length. Willing to add cash for the right boat. Call Warren (408) 821-8070.

LOOKING TO TRADE 3 TIMESHARES for sailboat 35' or larger. Timeshares in Las Vegas, Grand Cayman and Pompano Beach, FL. Combined value well over 80k, able to trade weeks in resorts worldwide. All offers considered. Respond to: parrothead95926@yahoo.com.



CHB 34, 1984. Great liveaboard or family cruiser. Single Perkins, 1,900 hours, 2 gph at 7 knots. Radar, GPSC, VHF, Bose speakers, flat screen, lots of spares. Professionally maintained. Downtown Sausalito slip. Looking to trade on 30-35' sailboat or sell outright. (415) 272-5056.

WANTED

CAN'T SELL YOUR BOAT? How about a tax write-off instead? JL Ministries is seeking a vessel for use in humanitarian outreach. Must be in good shape. Please contact the ministry via email at: windsongoutreach@gmail.com.

GEAR

NEW PARA-TECH SEA ANCHOR. 18-ft sea anchor for 35-48 ft boat or 25,000-40,000 lbs. displacement. Includes stowage bag, heavy-duty shackle, floatline, manual. New \$969. Asking \$485/firm. Cal 29 mainsail, good condition, 12' x 30' x 33'2", \$100. (831) 207-9059 or Twosailors@cs.com.

SAILS FROM SANTA CRUZ 40. #1 laminate jib light air, #1 laminate jib heavy air, #3 laminate jib, 1 huge North asymmetrical spinnaker, new condition, 1-3/4 oz symmetrical spinnaker. Best offers. Please call (831) 423-5431.

JABSCO ELECTRIC TOILET, 12 volt, seawater, 2001, lightly used for first year, \$200. Cruisair AC/heatpump SXR10, never used, \$1,300. Fiorentino para-anchor, lines all 1", bridle 175', rode 420', all hardware and retrieval gear, never deployed, \$3,500. Doug (707) 647-1715 or dougs13@sbcglobal.net.

PAIR NEW ALUMINUM LEWMAR #66 self-tailing winches, \$3,000/each. Three new aluminum Bariert #36 non-self-tailing winches, \$1,500/each. All are much larger than Lewmar 65s. New Racor 500FGSS fuel/water separators, \$150/each. Used teak swim platform, 116" wide, \$400. Call (707) 935-6951 or andrewpope@sbcglobal.net.



ISLAND PLANET SAILS
 Located in Alameda • Exceptional service • Attention to detail
 Quality materials from Bainbridge and Dimension Polyant
 World class design team with America's Cup experience
www.IslandPlanetSails.com • (510) 931-6499

BLUE PELICAN MARINE
 A sailor's consignment store now open at Grand Marina, Alameda
 Sails • Winches • Instruments • Blocks • Sailing Books
 Charts • Outboards • Rigging • Hardware • Safety Gear • More
(510) 769-4858 • BPM@alamedanet.net



MARINE SURVEYS by Captain Alan Hugenot
 Naval Architect • Yacht Delivery Skipper
 Accredited Marine Surveyor (SAMS)
 •• Bay or Delta • No Travel Charges •••
All major credit cards accepted • (415) 531-6172

30 HP WESTERBEKE MODEL 27A diesel engine, transmission, panel. 150 hours since rebuild. Stored for 5 years. Very clean. I've purchased a smaller engine for my boat. \$2,500/obo. San Diego. Tom (760) 741-6285.

FOUR ATOMIC 4 REPLACEMENTS. One A-4 rebuilt, totally cherry, \$3,200. One Westerbeke W-13 with velvet-drive, \$1,500. One Universal 5416, complete, \$1,900. One Yanmar GM20, \$2,000. (415) 272-5776.

INVERTER-CHARGER HEART HF12-2000SU with remote control panel. 12V DC, 2000W 120V AC modified sine, 65A DC charger, input AC transfer switch. In Redwood City. \$399. Email: Heart@Ricks-Cafe.net.

74-FT MAST DESIGNED for catamaran. Best offer. (415) 269-5165.

CLUBS & MEMBERSHIPS

SINGLE SKIPPERS AND CREW of all abilities are invited to join the Single Sailors Association. Membership includes daysailing, raft-ups, invaluable onboard training, social events. Meetings held 2nd Thursday, Oakland Yacht Club. Social 6:30 pm. Meeting 7:30 pm. Guests welcome. <www.singlesailors.org/> (510) 233-1064.

CLUB NAUTIQUE SAILING PASSAGE- maker Individual Membership. Learn to sail SF Bay and offshore. Enjoy member discounts on charters. See <www.club-nautique.net> Lists at \$3,995, asking \$3,595, and I'll pay your first full month dues. Call (530) 888-1395 or email: Clokdok@yahoo.com.

NON-PROFIT

SANTA CLARA POWER SQUADRON promotes boating (sail, power and paddle) with high standards in navigation and seamanship, offering members free classes ranging from Seamanship to Celestial Navigation plus cruises and social events. For details call (408) 225-6097 or see: <www.usps.org/localusps/santaclara/>

MARIN POWER & SAIL SQUADRON offers members free classes ranging from Seamanship to Celestial Navigation plus cruises and social events. Squadron Boating Courses are in Novato on Tuesday and Thursday nights, from 7 to 9 pm. Textbook \$50. For next course dates and registration call (415) 924-2712.

PROPERTY SALE/RENT

BRICKYARD COVE TOWNHOUSE. End unit on San Francisco Bay in Point Richmond and neighbor to the Richmond Yacht Club with private dock with 8-ft draw and 40-ft slip. Two stories, two bedrooms, 2.5 baths. All appliances: SubZero refrigerator, new Jenn-Air Downdraft gas range, new KitchenAid dishwasher, washer and dryer (gas), built-in vacuum. Gas fireplace in living room and master bedroom. Deck on front, side and rear of house and bedrooms. Single-car garage. Available for move-in on February 1 at \$3,500/month, first plus deposit, multi-year lease negotiable. Non-smokers only. Call Kristen for an appointment: (510) 233-7510.

BERTHS & SLIPS

BERTH AVAILABLE. 36-ft berth at Pier 39, San Francisco. Very close in. Rental by month or annually. (415) 474-2474.

50-FT PRIME SLIP, PIER 39, F-Dock, Slip 11, east side. Located by Marina office and shower, laundry and lounge. Protected from wind in afternoon. Great view of Bay and Pier 39. 24-hour security, easy parking with special rates for slip owners. Asking \$46,000. (559) 355-6572 or scorch@tempest-edge.com.

PIER 39 BOAT SLIP FOR RENT. 40-ft length, D dock, great location in the marina, views, benefits including showers and laundry, parking, \$380 month to month. Hopefully available February 1 pending repairs to the slip. (425) 643-0614.

CREW

EXPERIENCED CIRCUMNAVIGATOR, schooner, seeks select crew for Eastern Mediterranean. Legs: 1) Malta-Sicily-Italy-Albania-Greece. 2) Greek Isles-Turkey. 3) Turkey-Egypt-Israel. 4) Israel-Cyprus-Turkey. Legs approx. 4 weeks, June to October. Must participate fully and share expenses. Mike Johnson (505) 466-6326 or clairehorn@comcast.net.

JOBS WANTED

CAPTAIN, 100-TON MASTER available for local day trips, delivery, permanent/temporary. 14+ years international experience. Marina management experience. Strong resume' and references. Brad (954) 562-8860.

JOB OPPORTUNITIES

INVERNESS YACHT CLUB seeks Head Instructor for Summer Youth Sailing Program. 8 weeks employment, 6/22 to 8/21. Supervisory skills essential. 5 other Certified Instructors. Applicants must be US Sailing Instructor Level 1 Certified with appropriate experience. Inquire at: patwhitesf@aol.com.

SAILING EDUCATION ADVENTURES is a non-profit membership association that teaches sailing with volunteer instructors and organizes adult and youth sailing activities, including several summer camps. Currently seeking Program Director to coordinate volunteers, development and operations. Send resume to: Info@SFSailing.org.

BUSINESS OPPORTUNITIES



WELDING AND FABRICATING business with excellent reputation and solid client base for sale on Washington's Olympic Peninsula. Sale includes all equipment and raw materials in the 4,200 square foot building with 3-phase power. Equipment inventory is available. Opportunity for growth or ideal for retirement transition. Business, two-bedroom two-bath home, plus oversize double garage with upstairs guest room and bath are on 9+ wooded acres within walking distance of two salt-water marinas. \$624,000. Partial owner financing possible. Email: browled@olympen.com.

FOR SALE IN VANUATU. Bali Hai Yacht Charters and Diving Services. All inclusive. Licensed 38-ft trimaran, diving equipment, three moorings, car, motorcycle. Established 1985. Port Vila. \$150,000US/negotiable. Financing available. dennyswan@hotmail.com or CA until April: (760) 533-2515 or (909) 337-5240.



EARN RESIDUAL INCOME and sail more often. Network Xchange Associates specializes in teaching sailors / people who want to enjoy life with more freedom ... how to create multiple income streams. Call Chip Schumacher (916) 802-2305 or email: chip@nxainc.com.

READY FOR A LIFESTYLE CHANGE? Now is your opportunity by purchasing this growing property management business in Nicaragua. Get out of the rat race, start enjoying life in this beautiful, safe beach environment. Opportunity for growth is huge. Email: Janicegal@gmail.com.

TOO LATE TO CLASSIFY

SPARKMAN & STEPHENS 43. Corten steel custom cutter by Olin Stephens. Built by Bechtel for Pan American World Airways. Unique canoe stern, center cockpit, aft cabin, Perkins diesel. View Panam behind San Rafael Yacht Harbor office. \$88,000/obo. (562) 899-0774 or (415) 332-7245.

J/24, USA 513. Two-time season champion. Rebuilt and faired by local J/24 guru, Wayne Clough. Race ready, everything you need to go racing now including North sails, TackTick, outboard, and trailer. Dry stored in Richmond. \$12,000/obo. (408) 605-1163 or J24@yares.net.

ALBERG 30, 1970. Fun, full-keel ocean-going vessel. 6 sails. Tape Drive main and genny. Rebuilt Atomic 4. Sausalito. Nice shape, fun to sail the Bay. Liveboard ready. Great boat for Mexico or South Pacific. \$11,000. Call Matthew (415) 302-0562.



HERRESHOFF 45 KETCH, GIPSY JAC. Built by renowned boat builder John Clark, Oregon, 1989. See *Wooden Boat* article Jan/Feb, 1991 for details of construction. Sailed 2008 several times to Drakes, Tamales and Half Moon Bay. \$180,000. (510) 486-0103.

CATALINA 30 BOWSPRIT, 1976. Bow-sprit has better balance and more power than standard C30. Rebuilt Atomic 4 runs great. Tillermaster, 2 mains, 2 genoas, #2, 2 spinnakers. Martec, Harken hardware, excellent race record. dodger, AC/DC Refrigerator, stove/oven. \$16,000. (714) 376-4949 or gdavidson@socal.rr.com.

Yacht Repair
Design / Consulting

Custom Interiors
Exterior Joinery



STEVE'S MARINE WOODWORK

60 C Libertyship Way, Sausalito
jonessail@aol.com • (415) 332-2500

N.E. MARINE TITLE

Coast Guard documentation • Title/lien searches • Transfers • Mortgage filing • Escrow services
Local closing facility for brokers or private transactions
30 years experience of doing it right the first time

1150 Ballena Blvd, Alameda, CA • (510) 521-4925

OFFSHORE PASSAGEMAKING INSTRUCTION IN THE ATLANTIC

John & Amanda Neal are dedicated to providing hands-on, documented instruction aboard their Hallberg-Rassy 46 *Mahina Tiare III*, drawing on their combined 472,000 miles and 63 years of experience.

www.mahina.com • (360) 378-6131

Marine Architect / Designer

• 100 + Stock Plans Available • Custom Designing
John Seward • 105 Edison Ave. • Corte Madera, CA 94925
(415) 924-0429 • nims65@gmail.com

PROFESSIONAL YACHT DELIVERIES

60 years of combined experience • 100,000 miles at sea • USCG Licensed
Capt. Phil Howe (415) 290-1659 • Capt. Greg Snead (415) 846-6919
We'll get the job done in a safe, professional manner • Call for details

Need Crew? *Latitude 38 Crew Party* *A Boat to Crew on?*

Wednesday, March 11 • 6-9 pm • Golden Gate Yacht Club • 1 Yacht Rd, SF Marina
\$7 entry fee (\$5 under 25) • Munchies • No-Host Bar • Door Prizes • Demos
More info: www.latitude38.com/crewlist/Crew.html or call (415) 383-8200

TIRED OF HAND STEERING? GET THE CPT—THE RELIABLE, POWERFUL WHEEL PILOT

- Dependable ♦
- Affordable ♦
- Quiet ♦
- Built for Immersion
- Easy Owner Installation
- Low Power Consumption

The Delivery Skipper's Favorite

CPT AUTOPILOT

831-687-0541

www.cptautopilot.com



weatherguy.com

Worldwide Marine Forecasts Cruising, Racing & Commercial

Packages Starting at \$65.00 USD

(866) 882-WXGY (9949) toll free
(808) 291-WXGY (Mobile)
(808) 254-2525 (Office)
(808) 443-0889 (Fax)



970 N Kalaheo Ave
Suite C-104
Kailua, Hawaii 96734
info@weatherguy.com

www.weatherguy.com

COMPUTER ABOARD?

CAPN & Digital Charts
AIS • WiFi • Cellular Amps
SatPhones: Iridium & Globalstar
HF SSB Radio & Pactor Modems
Wireless E-mail



SEATECH SYSTEMS™

800.444.2581 • 281.334.1174
info@sea-tech.com • www.sea-tech.com

Call for Info on SeaTech Packages and CAPN Demo Disk

DFD DIESEL FUEL FILTERING



Purify Diesel Fuel & Clean Tanks

Process scrubs, polishes, removes algae, dirt, sludge, rust, water, and foreign particles from diesel fuel. Includes internal tank washdown. Save your injectors, costly engine repair and down time.

Since 1989. Fully insured. Your berth or boat yard.

(510) 521-6797 Fax: (510) 521-3309

Mathiesen Marine Services

For All Of Your Electrical & Electronic Needs

If you can't justify the cost of a new boat right now...

Make your old boat new again!

Modernize your existing boat with a safe, efficient electrical system & 21st century electronics!

Contact us today to discuss how we can help you put the joy back in your boat.

(510) 350-6622 www.MathiesenMarine.com



1 of only 3
MasterTechs in CA
-Fully Insured-

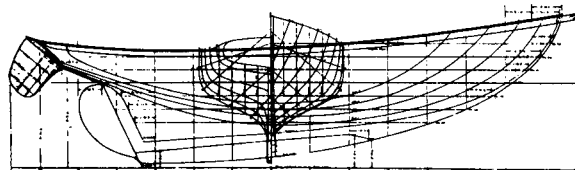

MAKELA BOATWORKS

Family owned since 1948

Wooden Boat Building • Repair and Restoration

19280 South Harbor Drive • Fort Bragg, CA 95437

(707) 964-3963

email: howard@makelaboatworks.com • www.Makelaboatworks.com

HAWAII

LONG TERM DRY STORAGE

Clear Customs at our dock

GENTRY'S
KONA MARINA

HONOKOHAU HARBOR

888-458-7896
TOLL FREE

156°1'30" W
19°40'20" N

The friendliest boatyard in Hawaii

WEDLOCK, RAMSAY & WHITING Marine Surveyors

Pre-purchase, insurance:
vessel, engine, rig surveys

*Serving the
Bay Area
since 1980*



www.norcalmarinesurveyors.com

(415) 505-3494

FAST SHIPPING!

NEW AND USED SAILS!

Specializing in production boats and featuring the largest selection of stock sails available anywhere! Save with warehouse volume discounts on Stock Sails, Custom Sails, Sail Covers, Furlers and Accessories. All top Quality.

All Fully Guaranteed!

- Full Batten Mains
- Furling Genoa's
- Storm Jibs
- Trysails
- Furling Units
- Custom Canvas
- Used Sails

THE SAIL WAREHOUSE

Ph. (831) 646-5346 www.thesailwarehouse.com

FREE CATALOG!!

MORE ENERGY!

KEEP BATTERIES CHARGED!

- KISS wind generators
- Solar panels and MORE

USE BATTERIES EFFICIENTLY!

- LED lights
- Engel fridge/freezers
- Port fans and more

HotWire

www.svhotwire.com 727.943.0424

DELIVERY CAPTAIN

We'll Do The Baja Bash For You! Book Now!

MARINE SURVEYS ALSO AVAILABLE

- ◆ 30+ Years Experience
- ◆ More Than 100,000 Miles at Sea
- ◆ Power and Sail
- ◆ Serving the Entire West Coast

BDI Marine Service
(707) 526-2418 • redwitchbbc@yahoo.com

La Paz Your Place *Your Marina Your Home in Baja*

Fuel Station • Free WiFi • Laundry
Filling of Propane Gas Tanks
And Many More....

Toll Free
1 877 217 15 13
www.marinapalmira.com

reservations@marinapalmira.com
Carretera a Pichilingue Km 2.5, Cp. 23010, La Paz, Baja California Sur, Mexico.

Bay Area Marine Surplus

MARINE CONSIGNMENT STORE

Bring in that excess equipment. Find the part you've been hunting for. Motors, sails, hardware, plumbing, electrical, pfd's, and much, much more. Come in and browse.

OPEN: THU 12-5 - FRI 9:30-6 - SAT 9-6 - SUN 10-4
130 Old County Road, Brisbane - tucked in the corner of the Brisbane Village Shopping Center, just west of Hwy 101.

415 508 0805 www.bamsurplus.com

RPARTS

REFRIGERATION PARTS SOLUTION

WE MAKE YOU THE EXPERT

"Do-It-Yourself" with RParts at unbeatable prices. We can help you fix a system or build it new.

Assembled Water-Cooled DIY Kit shown

www.rparts.com

ADVERTISERS' INDEX

AB Marine.....64	Ballenger Spars.....107	Blue Sky Energy101	BVI Yacht Charters.....184	Coyote Point Marina.....35
ABC Yachts.....186	Barillas Marina.....164	Blue Water Yacht Insurance ..68	Cal Marine Electronics.....51	CPT Autopilots176
Almar Marinas57	Bay Area Marine Services...177	Bluestorm65	CDI/Cruising Design134	Cruising World Pacific.....184
American Battery.....174	Bay Island Yachts.....181	Bluewater Network181	City Yachts15	Cruising Yachts7
Anacortes Yacht Charters ...151	Bay Marine Boatworks.....59	Bo'sun Supplies.....174	Clipper Ventures88,89	CYOA Yacht Charters151
Anderson's Boat Yard39	Bay Marine Diesel.....180	Boat US Insurance.....129	Clipper Yacht Harbor.....179	Desolation Sound
Annapolis Performance	BDI Marine Service/	BoatSmith Marine Carpentry	Coast Marine143	Charters.....151
Sailing107	Delivery Captain177	and Boatbuilding.....69	Conch Charters.....150	DeWitt Studio.....179
Aquatic Protection Agency..184	Berkeley Marina.....123	Bottom Siders.....178	Corinthian Yacht Club107	Diesel Fuel Filtering.....176
Baja Tourism Board55	Berkeley Marine Center.....49	Brisbane Marina.....71	Corsair Marine22	Dimen Marine Financing.....71
Ballena Bay Yacht Brokers ..181	Beta Marine Engines119	Butler Rigging179	Cover Craft73	Doyle Sails.....53

VOLVO PENTA

ENGINES • PARTS • SERVICE

1-800-326-5135

We Ship Anywhere

Call us for your nearest Volvo Penta dealer
1-800-326-5135

(415) 453-1001
FAX: (415) 453-8460
www.helmutsmarine.com
619 Canal Street
San Rafael, CA 94901



MARINE SERVICE INC
AUTHORIZED POWER CENTER

MARINE ENGINE CO.

PERKINS • YANMAR • ATOMIC 4 • VOLVO
WESTERBEKE • UNIVERSAL • BETA MARINE



CALL NOW FOR LOW ENGINE QUOTES

- Engine Repowering and Rebuilding
- Engine Sales, Service and Parts
- Complete Marine Engine Service

(415) 332-0455

GOLDEN STATE DIESEL MARINE

PARTS
YANMAR • UNIVERSAL • WESTERBEKE
PERKINS • ISUZU • PATHFINDER • ATOMIC 4

SERVICE
DIESEL ENGINES



Barbara Campbell

351 EMBARCADERO OAKLAND, CA 94606 **(510) 465-1093**

Save Your Aft!

Using one of our 1400+ patterns or your own pattern, let our craftsmen create a comfortable, durable, and stylish set of all-weather cushions for your cockpit. Find your custom, closed cell foam cushions at www.bottomsiders.com!



BottomSiders

Call Toll Free: (800) 438-0633
cushions@bottomsiders.com
Fax: 360-533-4474

BottomSiders
2305 Bay Avenue
Hoquiam, WA 98550

QUALITY SAILS FOR LESS!



NOW 10% OFF

MAINSAILS
MIZZENS
STAYSAILS
HEADSAILS
SPINNAKERS

(510) 523-3337 • leesailsnc@yahoo.com
2021 Alaska Packer Pl. • Grand Marina • Alameda, CA 94501

SAILMAKERS TO THE WORLD

MARINA DE LA PAZ FULL SERVICE MARINA

S.A. DE C.V.

Friendly, helpful, fully bilingual staff

All new hardwood docks • Wireless Internet
Dinghy landing with potable water
New protective piling & sheetpile breakwaters • And more!

TEL: 01152 612 122 1646
email: marinalapaz@prodigy.net.mx
www.marinelapaz.com
Apdo. Postal 290, La Paz, 23000, Baja California Sur, Mexico

ADVERTISER'S INDEX - cont'd

E Paint75	Garhauer Marine47	Helmut's Marine Service178	KKMI - Brokerage.....183	Lunasea Lighting.....65
Easom Rigging112	Gentry's Kona Marina176	Hogin Sails106	KKMI - Chandlery.....24	Makela Boatworks.....176
Elliott/Pattison Sailmakers ..128	Gianola & Sons.....172	Hood Sails43	KKMI - Electronics56	Maretron73
Emery Cove Yacht Harbor.....73	Glen Cove Marina.....132	Hotel Coral & Marina.....164	KKMI - Full Service Boatyard69	Marina Bay Yacht Harbor37
Emeryville Marina118	Golden State Diesel Marine178	Hotwire Enterprises177	Landfall Navigation.....113	Marina de la Paz178
Errol Flynn Marina.....10	Grand Marina2	Hydrovane71	Landing School, The74	Marina El Cid163
Essex Credit Corp.....77	H&S Yacht Sales8	Island Yacht Club58	Lee Sails178	Marina Nuevo Vallarta52
Farallone Yacht Sales9	Hanse North America45	JK3 Nautical Enterprises.....182	Lifeline Batteries.....169	Marina Palmira177
Flying Cloud Yachts17	Helms Yacht & Ship Brokers/ West Coast Multihulls23	Johnson Marine, C. Sherman48	List Marine Enterprises151	Marina Puesta del Sol168
Fortman Marina.....60		Kissinger Canvas.....67	Loch Lomond Marina166	Marina Real168
Fusion Catamarans67				Marina Riviera Nayarit41

dewitt

2009
NEW ART
NEW WEB SITES

Enjoy them all at:

www.jimdewitt.com
www.dewittgalleryandframing.com

DeWitt Art Gallery & Framing
121 Park Place, Point Richmond, CA 94801
(510) 236-1401 • (800) 758-4291

Tuesday-Thursday 11:00-5:00 ☺ Friday 11:00-3:00 ☺ Saturday 12:00-5:00



Thanks to Graham and Bianca Green for commissioning Jim DeWitt to paint their beautiful Knarr, 'Gjendin'.



WINTER RIGGING SAVINGS

Call Now!

*Ask About Lifeline Replacement
Cruise/Race • One Design Fleet Specials*

BUTLER RIGGING

(510) 672-2639
butlerrigging@sbcglobal.net

NEW LOCATION
BERKELEY
MARINE CENTER

"YOUR DESTINATION FOR A FULL SERVICE MARINA"
800 SLIPS 20-60 FT

Clipper Yacht Harbor

Sausalito, Ca

- Dry Storage Available
- Fuel Dock
- Salty's Bait & Tackle

- Sport Fishing
- Restaurant
- West Marine
- Launch Ramp
- Pump Out
- Laundry Facility

- Private Restrooms and Showers
- Anderson's Boat Yard
- Guest Slips Available



310 Harbor Drive, Sausalito, CA 94965
(415) 332-3500 ▪ www.clipperyacht.com

ADVERTISER'S INDEX - cont'd

Marina Village 18,19	McDermot Costa Insurance	North Sails - San Francisco... 16	Pineapple Sails.....3	R-Parts 177
Marine Engine Company... 178 128	Opequimar Marine Center . 169	Prime Fabrication 174	Ryan's Marine..... 51
Marine Lube 180	McGinnis Insurance..... 135	Orange Coast College 33	Pusser's Rum..... 4	Sail California 25
Marine Outboard Company	Milltech Marine Inc..... 32	Outboard Motor Shop..... 119	Quantum Pacific..... 27	Sail Warehouse, The 177
..... 172	Minney's Yacht Surplus..... 172	Owl Harbor 165	Quickline 75	Sail-A-Small-Boat Day - Richmond Yacht Club 72
Mariner's General Insurance	Modern Sailing Academy 29	Oyster Cove Marina 62	Raiatea Carenage Services..... 167	Sal's Inflatable Services 135
..... 14	Napa Valley Marina Yachts. 181	Oyster Point Marina 134	Real World Cruising 12	San Francisco Boat Works... 162
Maritime Institute 28,74	Nelson's Marine..... 188	Pacific Coast Canvas 65	Richard Boland Yacht Sales..... 182	San Juan Sailing 151
Marotta Yachts 185	Norpac Yachts..... 187	Pacific Yacht Imports..... 11	Richardson Bay Marina..... 169	Sausalito Yacht Club..... 54
Mathiesen Marine 176	North Beach Marine Canvas	Paradise Village 63	Rooster Sails 72	Scanmar International..... 77
Mazatlan Marine Center/ La Paz Yachts..... 31 51	Passage Yachts 5		Schaefer Marine..... 75
	North Direct Sails..... 132	Peter Crane Yacht Sales..... 182		



**Society of Accredited
Marine Surveyors®**

Serving Northern California

Al Blair, SA

415.456.3154

blairsurvey@comcast.net

Tom List, AMS®

415.332.5478

listmarine@yahoo.com

Jesse Brody, AMS®

415.342.0757

jesse@baymarinesurvey.com

Jack Mackinnon, AMS®/SMS

510.276.4351

surveyjack@aol.com

Alan Huguenot, AMS®

415.531.6172

huguenot@comcast.net

Randell Sharpe, AMS®

877.337.0706

rsharpe@alamedanet.net

Rick Whiting, SA

415.740.2924

captain_rick@sbcglobal.net

Size Matters.

-2.13 inches Wide
-1.35 inches Tall
-1.00 inches Deep

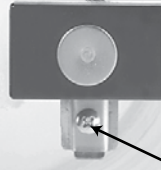

Mounting Tab

**Smallest
Bilge Switch
In the Industry**

Simply slide the stainless mounting tab under a hose clamp or drill (1) hole

www.WaterWitchInc.com

1-800-654-4783

Bilge Steam Cleaning Oil Changes

Professional service at your slip!!!

MarineLube™

877 744-2244

www.MarineLube.biz



Fuel Polishing

Tank Cleaning

**Marine Diesel Specialists
AT YOUR SLIP!**



30 years experience • Universal/Westerbeke dealers
Repairs/Tune-ups all models • Engine Surveys, Instruction

BAY MARINE DIESEL

510-435-8870

baymarinediesel@comcast.net

ATLANTIC 57 CATAMARAN™



THE ORIGINAL PILOTHOUSE CATAMARAN
o Designed for easy shorthanded cruising
o Spectacular windward performance
o Cored epoxy/glass/carbon construction

CHRIS WHITE DESIGNS

TEL: 508-636-6111

www.chriswhitedesigns.com

ADVERTISER'S INDEX - cont'd

Schmidt, Charlotte Yachts... 182	Starbuck Canvas 113	Trident Funding 6	West Marine.....38,40,42,44,70
Schoonmaker Point Marina 113	Svendsen's Boat Works.....21	Twin Rivers Marine Insurance 20	West Systems/Gougens Brothers 127
Sea Frost.....76	Svendsen's Marine 34	UK-Halsey Sails.....36	Westwind Precision Details ...51
Sea Scouts 174	Swedish Marine 69	Ullman Sails.....67	Whale Point Marine Supply ..66
Seashine.....76	The Boatyard at Grand Marina 13	Vallejo Marina 46	White, Chris Designs..... 180
Seatech..... 176	The Cruise Director 119	Ventura Harbor Boatyard77	Wright Way Designs 76
Society of Accredited Marine Surveyors/SAMS 180	TMM/Tortola Marine Management 150	Voyager Marine 143	www.mship.com..... 30
South Beach Harbor 50	Tradewinds Sailing Center....61	Waterwitch, Inc 180	WylieCat 133
South Beach Riggers.....51	TrawlerFest/PassageMaker Magazine.....26	Weatherguy.com 176	Yacht Racing Association 144,145
Spin Tec 133		Wedlock, Ramsay & Whiting Marine Surveyors 176	Yachtfinders/Windseakers31





Bay Island YACHTS

(510) 814-0400
 Fax (510) 814-8765
 In Grand Marina
 2099 Grand Street
 Alameda, CA 94501
 YACHTWORLD.com

NEW LISTINGS WANTED • FREE BERTH RENT TO QUALIFIED LISTINGS

34' CATALINA, 1988



\$46,900

FORMOSA 51, 1977



New listing...price to follow.

HUNTER 380, 2000



\$129,900

HUNTER 45, 1988



\$89,500

www.bayislandyachts.com
 yachtsales@bayislandyachts.com



Donate your Boat

Cars, Trucks, RVs, & Real Estate

We handle all DMV & Smog

Running or Not (restrictions apply)

Tax Deduction

BLUEWATER NETWORK | **800-324-7432**

"Proceeds help Bluewater Network reduce greenhouse gases, clean up our air and water, and protect marine mammals and wildlife."

Legendary cruising sailboats, high performance
 and unsurpassed seaworthiness.

In stock and at our docks.

www.ballenabayyachts.com

California
 dealers for

Valiant  Yachts

Made in
 the USA

B A L L E N A B A Y
 YACHT BROKERS

(619) 523-1151 ♦ (510) 865-8600

CELEBRATING OUR 50TH ANNIVERSARY



28' CAPE DORY
 1980 • \$19,900



35' IRWIN CITATION
 1985 • \$35,000



36' UNION POLARIS
 1980 • Needs work • \$46,000



37' IRWIN CENTER COCKPIT
 1972 • \$24,500



37' PROUT SNOWGOOSE CAT
 1985 • \$90,000



38' SPRAY REPLICA KETCH
 1992 • \$35,000



42' CATALINA MKII
 2006 • \$242,000



40' MARINER KETCH
 1973 • \$45,000



41' ATKINS INGRID FERRO
 CUTTER, 1971 • \$29,000



51' ATLANTIC PH STEEL KETCH
 1995 • \$139,000

39' YORKTOWN, 1977 • \$26,500

DRY STORAGE
\$4.00/ft
Power & Sail



NAPA VALLEY MARINA

1200 Milton Road • Napa, CA 94559

(707) 252-8011 • Fax (707) 252-0851

www.napavalleymarina.com

Marina • Boatyard • Chandlery • Brokerage

Dealers for
YANMAR

Interlux
 yachtpaint.com

Distributors for *Brownell*
 Boat Stands

JK³ BROKERAGE



38' TRUE NORTH, 2002
\$269,000



46' MOODY, 2000
\$285,000



40' DELPHIA, 2007
New, incredible value. \$209,000



40' J/120, 1998
\$205,000

55' Fairline Squadron, '00.....	675,000	36' Beneteau First 36.7, '07.....	169,900
45' Rivolta Coupe 4.5, '08.....	745,000	35' J/105, '02.....	SOLD!
42' Rivolta Express.....	Call for pricing	35' J/105, '97.....	109,000
42' Rivolta PT Runner.....	Call for pricing	35' J/109, '07.....	239,000
40' Rivolta Coupe 4.0.....	Call for pricing	35' J/109, '06.....	225,000
40' J/120, '98.....	199,000	33' Delphia.....	Call for pricing
40' C&C Express, '02.....	215,000	33' Maxi Dolphin Cross Currents, '06.....	Call
40' Raider Cabin, '05.....	272,500	32' C&C, '84.....	38,500
38' True North, '05.....	369,000	29' Luhrs 290, '98.....	87,000
38' Pearson True North, '04.....	345,000	29' Back Cove, '07.....	199,000
37' Delphia.....	Call for pricing	25' Hunt Harrier, '07.....	Call for pricing
37' Santa Cruz, '09.....	399,900	22' Raider RIB 680, '07.....	49,690



Yacht Sales & Service **YACHTWORLD.COM** www.jk3yachts.com

SAN DIEGO: 2330 Shelter Island Dr. #106
(619) 224-6200 • FAX: (619) 224-6278

NEWPORT BEACH: 251 Shipyard Way, Suite A
Toll-Free: (866) 376-7761

Tel: (949) 675-8053 • Fax: (949) 675-0584

Jeff Brown Roy Bream Whit Batchelor

Richard Boland Yachts

1070 Marina Village Pkwy #107, Alameda 94501
Ph: (510) 521-6213 Fax: (510) 521-0118
www.richardbolandyachts.com



50' HOLMAN FAST CRUISING CUTTER, 1989
Single Yanmar diesel, 2 state-rooms/heads. Complete refit. Looks NEW & ready for sea. Try \$199,900



55' ACTIVA LONG RANGE SKYLounge MOTORYACHT
Twin Cummins 670 hp, 3 state-rooms, 2 heads, molded stairs to enclosed spacious bridge, 16'7" beam, 1,000 gallon fuel w/added gallons optional. Ask for Richard.



60' GILS CATAMARANS CRUISING CATAMARAN, 1988
Single diesel, 4 staterooms/2 heads, generator, inverter, fully equipped, varnished wood interior. Try \$187,000

Peter Crane Yacht Sales and Charters

In Santa Barbara - experienced, interested, friendly, low pressure Brokerage without walls

Peter Crane Mark Scott-Paine Don Hedden James Lambden



1980 Skye 51 ketch
Kaufmann&Ladd design full cruise teak decks, just reduced \$199 K



1974 Morgan 41 ketch
sturdy, roomy, full keel cruiser sensible solid equipment \$61 K



1974 Formosa 51 PH
comfortable cruising boat a lot of good boat for only \$85 K



1986 Pearson 385 CC
beautiful layout, well equipped recent survey \$87.5 K



Debonair, a 44' ketch
from a design by Edson Schock built 1974 by Don Ward this is really a good one 139K



1981 Herreschoff 36 ketch
traditional good looks in glass well equipped solid jewel \$84 K

Info/photos: www.petercraneyachts.com
pc@petercraneyachts.com
(805) 963-8000

CHARLOTTE SCHMIDT

YACHT SALES

When Experience Counts

4100A Harbor Blvd.
Oxnard, CA 93035
Fax (805) 382-2374

In SF Bay Area: (415) 613-0712

(805) 382-2375

Csyachtsales@cs.com

www.yachtworld.com/charlotteschmidt



49' JEANNEAU SUN ODYSSEY, 2006
Yanmar diesel, inverter, 4kw genset, bow thruster, furling main, Raymarine electronics, watermaker, full inclosed cockpit, dodger. Excellent condition! At our docks. Asking \$375,000



36' GRAND BANKS CLASSIC Trawler, 1988
Twin 135 hp diesels, Onan genset, inverter, radar, autopilot, air, excellent condition, fine example of the wide body GB Classic. Must see! Asking \$189,500



34' GEMINI 105M CATAMARAN, 1997
Many great features, Westerbeke diesel, autopilot, chartplotter, furling jib, excellent condition! Asking \$115,000. Contact owners' listing agent Gary Kaplan at (415) 613-0712.



40' HUNTER LEGEND, 1993
Yanmar diesel, inverter, wind generator, autopilot, radar, watermaker, dodger, furling boom, ready for sailing Mexico! Asking \$129,000



43' CUSTOM STEEL CUTTER, 1992 John Deere 85 hp dsl, hard dodger, radar, AP, GPS, wind generator. Stout offshore cruiser. Contact listing agent Linda Singleton at (707) 853-6614.



36' CATALINA MK II, 1996 Universal diesel, inverter, radar, AP, bimini/dodger, recent haulout, beautiful condition. Asking \$89,900. Contact Capt. Jack for viewing at (805) 890-2623.

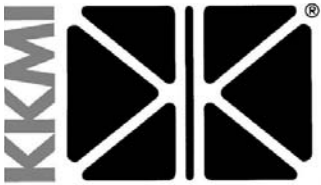

Maritime Yacht Brokerage

☎(510) 236-6633 • fax: (510) 231-2355

yachtsales@kkmi.com • www.kkmi.com

530 W. Cutting Blvd., Pt. Richmond, CA 94804



DeVries 86' Motor Vessel (1949/1999)
"Elegant", "Exceptional", "Exquisite" are just a few words that easily characterize this vessel. *MV Far Niente* clearly defines the term 'Classic Motor Yacht'.
Asking **\$2,700,000**



63' Custom Steel Pilothouse LRC (1976)
Ready-to-go global cruiser just completed \$100,000 maintenance/upgrade service. Twin 185hp Perkins for economy and dual gensets. Three cabins + crew's quarters. Asking **\$389,000**



Sydney 36 CR (2006) w/fractional rig, four swept-back spreaders, non-overlapping head sail, high aspect ratio and very long waterline. Extremely competitive IRC racer. Fitted w/all factory options incl. electric winches, extensive sail inventory and rigging set by Easom, *Encore* is arguably the best 36 built. **Inquire**



Beneteau First 40.7 (2001)
White Dove has just won the 2008 West Coast IRC Championship and is in top condition.
Asking **\$199,500**



Swan 371 (1981)
A Ron Holland design which is very well equipped with newer electronics, sails and has been well maintained.
Asking **\$149,000**



Swan 42 (2007)
Nautor Club Swan 42 *Amelia* has a winning record and has been prepared for racing at the highest level. All class legal rigging modifications completed. Asking **\$700,000**



Grand Banks Eastbay 38 HX (2003)
A premier designer and quality builder make the Eastbay a first class motor yacht. Extensive factory options, comprehensive electronics and superbly maintained. **\$365,000**



Swan 53 (1987)
Mistress has been exceptionally well maintained by a professional crew and is a beautiful Swan 53. Her factory-installed aft companionway makes her much more accessible than the standard 53. She has a new teak deck and is in excellent shape. Asking **\$575,000**



Swan 43 (1977)
S&S-designed motorsailer is a very comfortable and spacious two cabin, two head cruising yacht. A one-owner yacht that is immaculate and in absolutely Bristol condition. Asking **\$199,000**



Swan 411 (1979)
With essentially every aspect of the yacht upgraded or replaced, this S&S-designed racer/cruiser is arguably the best mid-size vintage Swan on the market. Winner of the San Diego YC's prestigious 'Best Maintained Yacht Overall'. **\$190,000**



Mumm 30 (1996)
A turn-key race boat immediately available on the West Coast. Well maintained with fresh sails and trailer. Asking **\$75,000**



Swan 59 (1985)
Shadowfax is your true world cruiser. The boat has had an extensive refit and new teak decks. A classic Swan with the strength to go anywhere in the world. Asking **\$499,000**



Swan 45 (2003)
Race or cruise. *Rancho Deluxe* won her class in the TransPac and was second twice in the Big Boat Series. This boat has all the gear to go cruising and is in perfect condition. **\$625,000**



Offices Independently Owned

EXCITING NEW LOCATION by Svendsen's Boatyard

Cruising World Pacific

New address! 1919 Clement Ave., Alameda, CA 94501

(510) 764-1734

5060 N. Harbor Dr., Suite 165, San Diego, CA 92106

www.yachtworld.com/cruisingworldpacific



60' Custom Aluminum Cutter



Auto Fax Back
(888) 827-1891 ext. 5143

DESCRIPTION

			24/7 ext.
70' Andrews	1998	\$339,000	5223
60' Custom Aluminum	1992	new listing	5143
52' Tayana CC Cutter	1991	\$295,000	7253
48' Liberty 458	1983	\$175,000	5173
42' Catalina tri-cabin	1989	\$ 99,999	3173
37' Endeavour sloop	1978	\$ 55,000	7123
36' Catalina MkII	2000	\$114,900	7133
36' Columbia sloop	1968	\$ 29,900	7163
32' Capital Gulf	1985	\$ 49,995	7213
31' Prout Cat	1983	\$ 79,000	5123

Power Listings

62' Skipperliner Tour	1994	\$499,950	5243
60' Lien Hwa Flushdeck	1985	\$334,900	7523
48' North Sea Trawler	1971	\$199,000	7603
40' Bluewater PH Trawler	1979	\$175,000	5063
23' Campion Fisherman	2003	\$ 29,000	4123



37' Prout Snowgoose

Lots of NEW gear!
\$124,500

Auto Fax Back
(888) 827-1891 ext. 3243

**You can receive a boat info sheet via our 24/7 Auto Fax Back
Call (888) 827-1891 then dial 4-digit extension**

LOOKING TO BUY A BOAT IN THE BVI?



BENETEAU 50.4, 2007
Jacomina H.
\$300,000



BENETEAU 473, 2005
Cacafuego. AC & genset. \$229,000



BENETEAU 46, 2007 Jasper
AC and genset. \$294,000



BENETEAU 323, 2004
Chablis. \$85,000



BENETEAU 40, 2007 Shiraz
\$206,000



B.V.I. Yacht Charters
Joma Marina,
Tortola, BVI
(284) 494-4289
(888) 615-4006
charters@bviyc.com
www.boatshedbvi.com

yachts in photos may be sisterships

DONATE YOUR BOAT

to the Aquatic Protection Agency.
We protect our precious coastal waters from illegal toxic pollution. We can use your equipment, so you will get maximum value for your donation.

**Call 415-235-0756
or 831-915-8190**



boats@aquaticprotection.org

We are on the water, monitoring cruise ships, performing BlueBoater trainings, and testing outfalls for harmful toxins.

www.AquaticProtection.org



Marotta Yachts of Sausalito

Brokers of Fine Sail and Motor Yachts

415-331-6200 • info@marottayachts.com



REDUCED

See at:
www.marottayachts.com

49' GRAND BANKS TRAWLER, 1980

Grand Banks are well built, proven passagemakers, and this particular example is in really REALLY nice shape inside and out. Some highlights include a flawless solid teak updated interior, new teak decks, perfect gelcoat and brightwork. Prime transferable Sausalito YH slip, competitively priced. **\$249,000**



38' HUNTER 386 LE, 2004 This one-owner, never chartered, professionally maintained Hunter shows bristol topside and below. Gelcoat is perfect and interior looks brand new. She's the deep draft version, is well equipped from the factory (she's the LE version) and has an extensive suite of electronics and only barely 400 hours on the spotless Yanmar diesel. Must see. **\$149,500**



See at:
www.marottayachts.com

40' CATALINA 400, 1997

Maintained bristol, this boat has been only lightly sailed and literally shows as new inside and out. High-lights: Extensive suite of fully integrated electronics, sails show no wear whatsoever, beautiful custom dodger, interior perfect, much more, must see. One of the nicest on the market. **\$139,000**



See at:
www.marottayachts.com

38' HANS CHRISTIAN TRADITIONAL, 1984

The 38 Traditional is a lovely modern classic and this particular example is in very nice inside and out. Some highlights: new main in 2003, new roller furler in 2001, all new electronics in 2001, epoxy barrier-coated bottom painted 2001. **\$134,900**



REDUCED

See at:
www.marottayachts.com

36' CASCADE CUTTER, 1989 Custom-built raised cabintop cutter that was designed specifically for a cruise that was never taken, almost \$30,000 spent over the past couple of years. She shows very nicely today — new electronics, new sails and rigging, low time on the Yanmar diesel and a hard dodger that's a work of art. She's ready to head anywhere you see fit. **\$89,000**



See at:
www.marottayachts.com

34' SUNSET SLOOP, 1967

This full keeled little jewel was designed as the ultimate Bay daysailer and built like a piano by Al Silva shortly after he left the legendary Stone Boat Yard. Fully restored, she's one of the finest boats of this era we've ever seen; everything's done to showboat standards. **\$69,500**



SALE PENDING

39' COLUMBIA CENTER COCKPIT, 1979

This yacht had more than \$30,000 spent since 2002. Rebuilt engine, new mainsails, renewed rigging, replumbed, rewired, replaced original plastic portholes with ABI stainless steel, new custom hard dodger, etc. **\$69,000/Offers Encouraged**



REDUCED

See at:
www.marottayachts.com

34' TARTAN Mk II

S&S design in OUTSTANDING shape inside and out — meticulous long-term owners and spent the first 15 years of her life in fresh water. Most systems have been updated, including electronics and sails. With less than 500 total hours on her Yanmar diesel, she's been very lightly used. **\$64,990**



REDUCED

See at:
www.marottayachts.com

30' NONSUCH ULTRA, 1987 Professionally maintained late-model example in super nice shape (the interior is flawless and the exterior comes close), and lying in a transferable Sausalito Yacht Harbor slip that has a great Richardson Bay, Angel Island and San Francisco views. All in all, a nice turn key package that must be seen to be appreciated. **\$64,000**



See at:
www.marottayachts.com

35' SANTANA, 1979 Deep lead keel and fractional rig make for a stable ride on the Bay whether racing or daysailing and this particular example is in fine shape with an \$18k refit in '04 — all new rigging, reworked mast/boom, new Navman wind instruments, new batteries. Additional work done since incl. new: depthsounder, stereo, exhaust elbow, cushion covers. **\$23,000**



27' CATALINA, 1981

With \$12,000 spent on recent upgrades, this is one of the nicest on the market: new sails, new ProFurl roller furler, new running rigging, new self-tailing main halyard winch, perfect exterior brightwork, new cushions below, bottom just painted August 2008. Plus transferable Sausalito YH slip. **\$16,000**



27' CATALINA, 1984

One of the most popular small sailboats ever launched! This is a very clean example with diesel engine, dodger, roller furler, self-tailing winches, tiller steering and boom tent. Note lying transferable Sausalito YH slip right off the boardwalk. Nice inexpensive turn-key package! **\$16,000**

100 BAY STREET • SAUSALITO • CALIFORNIA 94965



GULFSTAR 50, 1979

Two staterooms. Major upgrades:
SSB, liferaft, AP, diesel heat, more.
\$124,000

Anchorage Brokers & Consultants YACHTS



www.yachtworld.com/anchoragebrokers
#1 Gate 5 Road, Sausalito, CA 94965

(415) 332-7245
yachts@abcyachts.net

25 Third Street,
San Rafael, CA 94901
(415) 457-9772

CLAY & TERESA PRESCOTT • GEORGE HIGBIE • PHIL HOWE • LARRY MAYNE • DANA PAUL • ARNIE GALLEGOS • PETER BOHN • JOHN SAUL • CRAIG SHIPLY • ERIC NOAH



REDUCED

PASSPORT 42 PH, 1984
Nicely equipped & clean.
~~\$149,500~~ to **\$130,000**



44' BREWER CC KETCH, 1985
Great for passages or liveaboard. Sausalito slip.
\$99,000



59' CUSTOM CB KETCH PH, 1978
Built in Australia. 3 stnm + capt. **\$155,000**
Also: 48' C&C L.F.



65' CUSTOM CC PH CUTTER, 1994
Fiberglass. Diesel. Passagemaker.
\$139,500



CATALINA 36, 1993, \$85,000
Also: CATALINA 34, 1989, \$54,500
Both real nice.

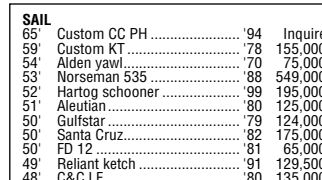

40' BRISTOL CLASSIC, '74
New Awlgrip. New electronics. New ultra suede.
Sausalito slip. **\$83,000**

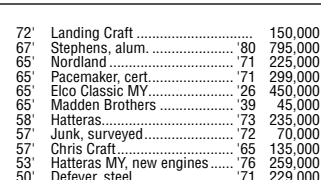

40' SANTA CRUZ 50, '82
Super clean! Cruise or race mode. Still one
of the fastest downwind. **\$175,000**



43' HANS CHRISTIAN, 1989
Cutter, Telstar, low hours. **\$210,000**
Also: 33' HC, 1986, **\$112,000**



**BEST ISLANDER 36s ON THE BAY
1979, \$55,000 Reduced to \$47,000**
Also: 1977, \$50,000

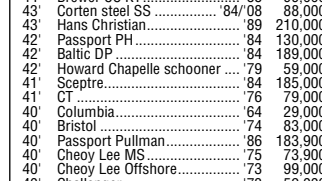

40' CHEOY LEE OFFSHORE, 1973
New blue Awlgrip.
New elec. panel. New fuel tanks.
\$99,000

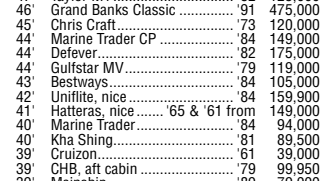

40' CHEOY LEE RHODES OFFSHORE, 1973
New teal deck.
New blue Awlgrip.
New elec. panel. New fuel tanks.
\$99,000



40' CHEOY LEE RHODES OFFSHORE, 1973
New teal deck.
New blue Awlgrip.
New elec. panel. New fuel tanks.
\$99,000



46' GRAND BANKS, 1991
Classic Bristol. **\$475,000**
Also: 48' OCEAN ALEXANDER
2006, **\$599,000**
48' OFFSHORE, 1991, **\$359,000**

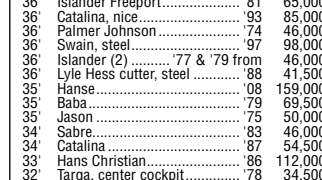

46' GRAND BANKS, 1991
Classic Bristol. **\$475,000**
Also: 48' OCEAN ALEXANDER
2006, **\$599,000**
48' OFFSHORE, 1991, **\$359,000**

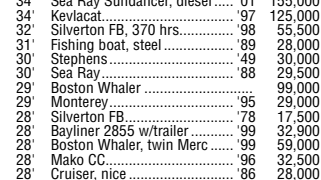

46' GRAND BANKS, 1991
Classic Bristol. **\$475,000**
Also: 48' OCEAN ALEXANDER
2006, **\$599,000**
48' OFFSHORE, 1991, **\$359,000**



46' GRAND BANKS, 1991
Classic Bristol. **\$475,000**
Also: 48' OCEAN ALEXANDER
2006, **\$599,000**
48' OFFSHORE, 1991, **\$359,000**



46' GRAND BANKS, 1991
Classic Bristol. **\$475,000**
Also: 48' OCEAN ALEXANDER
2006, **\$599,000**
48' OFFSHORE, 1991, **\$359,000**



46' GRAND BANKS, 1991
Classic Bristol. **\$475,000**
Also: 48' OCEAN ALEXANDER
2006, **\$599,000**
48' OFFSHORE, 1991, **\$359,000**

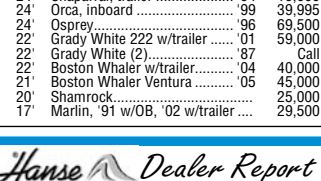

46' GRAND BANKS, 1991
Classic Bristol. **\$475,000**
Also: 48' OCEAN ALEXANDER
2006, **\$599,000**
48' OFFSHORE, 1991, **\$359,000**



46' GRAND BANKS, 1991
Classic Bristol. **\$475,000**
Also: 48' OCEAN ALEXANDER
2006, **\$599,000**
48' OFFSHORE, 1991, **\$359,000**

SAIL			
65'	Custom CC PH	94	Inquire
59'	Custom KT	78	155,000
54'	Alden yawl	70	75,000
53'	Norseman 535	88	549,000
52'	Hartog schooner	99	195,000
51'	Aleutian	80	125,000
50'	Gulfstar	79	124,000
50'	Santa Cruz	82	175,000
50'	FD 12	81	65,000
49'	Reliant ketch	91	129,500
48'	C&C L.F.	80	135,000
47'	Perry cutter	80	99,000
45'	Downeast	77	89,000
45'	Noble CC steel	05	150,000
44'	Islander schooner	80	85,000
44'	Pearson Countess	65	89,000
44'	Brewer CC KT	88	99,000
43'	Corten steel SS	'84/08	88,000
43'	Hans Christian	89	210,000
42'	Passport PH	84	130,000
42'	Baltic DP	84	189,000
42'	Howard Chapelle schooner	79	59,000
41'	Sceptre	84	185,000
41'	CT	78	79,000
40'	Columbia	64	29,000
40'	Bristol	74	83,000
40'	Passport Pullman	86	183,900
40'	Cheoy Lee MS	75	73,900
40'	Cheoy Lee Offshore	73	99,000
40'	Challenger	73	59,000
38'	Morgan (2)	'78 & '84	44,000
38'	Ingrid (2)	'76 & '84	61,000
38'	Rafiki, new engine	07	77
37'	Esprit (Panama)	78	78,950
36'	Union	79	63,000
36'	Islander Freeport	81	65,000
36'	Catalina, nice	93	85,000
36'	Palmer Johnson	74	46,000
36'	Swain, steel	97	98,000
36'	Islander (2)	'77 & '79	46,000
36'	Lyle Hess cutter, steel	88	41,500
35'	Hanse	08	159,000
35'	Baba	79	69,500
35'	Jason	75	50,000
34'	Sabre	83	46,000
34'	Catalina	87	54,500
33'	Hans Christian	86	112,000
32'	Targa, center cockpit	78	34,500
32'	Westsail (2)	'77 & '79	48,500
32'	Odyssey, nice	67	75,000
32'	Coronado	73	26,000
31'	Pacific Seacraft Mariah	79	59,900
31'	Cape George Cutter	00	142,500
31'	Cal w/trailer	79	23,999
30'	Catalina (2)	'75 & '81	16,500
30'	Islander (2)	'74 & '75	15,000
30'	Islander Bahama		24,000
30'	Lancer	80	32,500
27'	Nor Sea w/trailer	77	39,900
26'	Alden	33	11,000
POWER			
140'	Canadian Vickers	38	1,200,000
85'	Broward, alum	81	890,000
72'	Landing Craft		150,000
67'	Stephens, alum	80	795,000
65'	Nordland	65	225,000
65'	Pacemaker, cert	71	299,000
65'	Elco Classic MY	26	450,000
65'	Madden Brothers	39	45,000
58'	Hatteras	73	235,000
57'	Junk, surveyed	72	70,000
57'	Chris Craft	65	135,000
53'	Hatteras MY, new engines	76	259,000
50'	Delever, steel	71	229,000
50'	Stephens (2)	'63 & '65	135,000
50'	Whitcraft (bluewater)	79	118,000
48'	Ocean Alexander	06	599,000
48'	Offshore	91	359,000
48'	Dutch canal barge	50	219,000
47'	Taylor MY	82	125,000
46'	Grand Banks Classic	91	475,000
45'	Chris Craft	73	120,000
44'	Marine Trader CP	84	149,000
44'	Delever	82	175,000
44'	Gulfstar MV	79	119,000
43'	Bestways	84	105,000
42'	Uniflite, nice	84	159,900
41'	Hatteras, nice	'65 & '61	149,000
40'	Marine Trader	84	94,000
40'	Kha Shing	81	89,500
39'	Cruizon	61	39,000
39'	CHB, aft cabin	79	99,950
39'	Mainship	89	79,000
39'	Donz ZSC	02	219,000
38'	Chris Craft	64	39,000
38'	Holiday Mansion	89	38,500
35'	Cooper Prowler	86	55,000
34'	Atlantic SF	89	79,000
34'	Sea Ray Sundancer, diesel	01	155,000
34'	Kevlacat	97	125,000
32'	Silverton FB, 370 hrs	98	55,500
31'	Fishing boat, steel	89	28,000
30'	Stephens	49	30,000
30'	Sea Ray	88	29,500
29'	Boston Whaler	99	99,000
29'	Monterey	95	29,000
28'	Silverton FB	78	17,500
28'	Bayliner 2855 w/trailer	99	32,900
28'	Boston Whaler, twin Merc	99	59,000
28'	Mako CC	96	32,500
28'	Cruiser, nice	86	28,000
27'	Skagit Orca XLC	98	85,000
27'	Seaport w/trailer	96	90,000
26'	Osprey long cabin	03	85,000
26'	Osprey	02	98,000
25'	Albin	75	28,000
25'	Skipjack	85	50,000
24'	Chaparral, trailer	94	19,000
24'	Orca, inboard	99	39,995
24'	Osprey	96	69,500
22'	Grady White 222 w/trailer	01	59,000
22'	Grady White (2)	87	Call
22'	Boston Whaler w/trailer	04	40,000
21'	Boston Whaler Ventura	05	45,000
20'	Shamrock	20	25,000
17'	Marin, '91 w/OB, '02 w/trailer		29,500

Hanse Dealer Report

SEVEN REASONS TO OWN A HANSE:
EASE OF USE, SAFETY, COMFORT,
PERFORMANCE, QUALITY, STRENGTH & PRICE.
Give us a call for a demo sail on the Hanse 350.

Larry R. Mayne - Yacht & Ship Broker
Dealer & New Boat Sales Manager
Sales dock slip available, \$300/month



HANSE 350
Last year's model (2008).
\$159,000

NORPAC YACHTS

1150 Brickyard Cove Rd., B9, Pt. Richmond, CA 94801

(510) 232-7200 • FAX (510) 232-7202

email: info@norpacyachts.com

HAPPY DAYS ARE HERE AGAIN!

Let's go boating!

FOR MORE
SEE OUR

norpacyachts.com

WEBSITE



CALIFORNIA HISTORICAL VESSEL
43' D.M. CALLIS CLASSIC 1923 Cust. Express Cruiser, *Mar-darin*. TEAK masterpiece. Famous from roaming '20s on Catalina, Hollywood, etc. Now exquisitely & totally refit w/modern everything discretely incorporated & true to designer's original intent. Exceedingly rare opportunity, AND she is fast! **Ask \$695,000**



REDUCED
40' X-YACHTS X-119 SLOOP. Famous Danish builder, Racer-Cruiser one design by Neils Jeppesen. Loaded with gear, RADAR, New Volvo Penta Diesel in 2000 & MORE! Proven ocean winner in Melbourne-Osaka Race. **Asking \$109,000**



REDUCED
57' CHINESE JUNK. Teak const. Huge & very comfortable well lit & well appointed inter. Outstanding liveboard cruiser w/lug rig & highly desirable Gardner dsl. Charm, character. Gen set, washer/dryer. Pos. liveboard slip & more! **Asking \$79,950**



FANTAIL MOTORYACHT
82' FAIRMILEM/Y by Burwick Shipyard of Tweed, Scotland. Unusually robust. Twin CAT diesels, 2 gensets, Vosper stabilizers, 5 strms, 4 heads, lg salon, W/H, sheltered aft deck & MUCH MORE! Operational, partially refit; but unfinished. A wonderful ship at a very reasonable **\$400,000 Asking Price.**



STROMA OF MEY
38' CLASSIC ENGLISH KETCH. Award winning beauty in fine condition. Pitch pine over oak, copper riveted. Dsl, dodger, new teak decks, RADAR, gorgeous interior & MORE! Designed by Reg Freeman, built 1936 by Wm King & Son. **Ask \$124,950**



40 SAMPSON C-Ghost Cutter, F/C, Mexico. Vet and ready to go again. Excellent cruiser. Catalina, wheel, dodger, enclosed marine head, shower, galley, A/P, GPS, + MORE! Very nice condition and a GREAT VALUE! **Asking \$39,000**



31' PEARSON Aux. Sloop. A nicely updated and unusually shipshape vessel in fine condition. Diesel, new upholstery, nav. station, VHF, GPS ++. **Ask \$14,750**



31' MONTEREY BAY Pilothouse Express w/trailer. High quality. Excellent condition. Twin 130 hp YAMAHA's. USCG documented. AP, head, pressure water and wash down, video depth, bunks and MORE! **Ask \$29,950**



50' TRUMPY raised Pilothouse LRC Trawler. Strong, comfortable, seakindly & economical, RADAR, A/P, Detroit 671-N main, Aux. genset, 2 heads, shower, tub, dbl & queen strms, full galley, lg salon, dbl plank & built by famous John Trumpy & Sons Yard of Chesapeake Bay. MUST SEE. **Ask \$78,950**



34' LOD Wm. GARDEN KETCH by FELLOWS & STEWART, 1976. An outstanding vessel by an outstanding architect and an outstanding builder in outstanding condition. Diesel, roller furling, carved planked. GREAT BUY in a beautiful traditional yacht. **\$19,500 Ask**

SAIL
100' MEGA SLOOP Custom Offshore Performance Cruiser. Comfort & luxury, spacious, sleeps 17, loaded & near new. GREAT CHARTER POTENTIAL!!! Asking 975,000
58' lol STEEL SCHOONER, near new, 19th Century Privateer motif, great pleasure or charter yacht..... Asking \$449,950
50' CAULKINS Slip. A project, but all there. Dsl, strip plank, ocean racer..... Try 15,000
44' FELLOWS & STEWART Aux. Sloop. 1/B, A Fine Traditional from a Fine West Coast Builder..... Asking 35,000
43' SPARKMAN & STEPHENS steel custom cutter by Olin Stephens. Major upgrades. Center cockpit, aft cabin, new elect. syst., diesel and more. FULL REFIT NEARLY COMPLETED: BEAUTIFUL! Asking 98,950
42' Sparkman & Stephens Performance Cruising Slip. Dsl, dodger, F/G, many upgrades & new rig..... Asking 48,950
40' TRIMARAN by Piver. Ketch, dsl, fast, nice, clean. Insures as F/G..... Ask 33,900
40' CHEY LEE Offshore 40/Rhodes, F/G, teak cabins, loaded cruiser..... Asking 49,500
40' CHALLENGER, ketch, F/G, dsl, aft S/R, cruise gear, very clean..... Asking 64,000
39' FREYA Double-ender, steel, dsl, drink-a-b, new paint, solar, furling, radar, AP, cruise equipped & more!..... Asking 48,950
37' VILLENAVE Cruising Ctr Blue Water Euro Performance. Loaded..... Asking 43,950
37' ISLANDER Sloop. Inboard, ever popular "Plastic Classic"..... Asking 18,950
36' NIELSEN classic 1918 Danish aux. sloop. Diesel. Nice..... REDUCED..... Try 8,500
36' SPARKMAN & STEPHENS Center Cockpit Cruising Slip. Dsl, F/G, wheel, ++... 24,950
36' S2-11m Slip, dsl, shower. Clean. 47,950
30' PT30 Mk II 1/2-ton Britton Chance design. 5 berths, full headroom, solid F/G hull, furling, dsl, 3 headsails (135% & #4 gennies, 3/4 & 1.5 oz kites), spinn., main++...9,950
30' SAGITTA Slip. F/G, dsl, fine Danish double-ender..... Reduced..... Ask 14,950
30' CATALINA Slip. Dsl, wheel, nice... 22,000
30' CAL Cr. Dsl, furling, MORE! Ask 11,950
29' PEARSON TRITON. New diesel. Total refit nearly done..... Asking 15,950
27' BALBOA Sloop. Diesel auxiliary, wheel, standing headroom, 2-axle EZ-loader trailer. Lyle Hess design, GPS, VHF, extra clean & MORE!..... REDUCED! Asking 10,475
27' CHEY LEE Offshore. Dsl, GLASS, Classic Design & MORE!... REDUCED! Asking 7,500
27' CAL 2-27 Slip. Extra nice, 1/B. Ask 5,750
23' HERRESHOFF Classic PRUDENCE Sloop with 2003 Honda..... 7,500

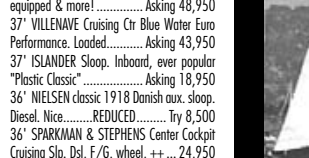

34' DUFOUR sloop. Diesel, enclosed head and shower. Full galley, spinnaker, nav. station, wheel steering. TEAK and holly sole and more. Excellent performer with quality construction and lots of room (6'6"+headroom). **Asking \$32,500**

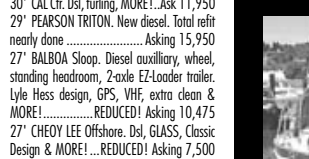

31' PACIFIC SEACRAFT "Mariah" Cutter. Strong FG Double-Ended World Cruiser by Crealock. Dsl, wheel, furling, dodger, RADAR & more! An outstanding vessel for everything from Bay sailing to Blue Water cruising. **Ask \$68,950**

POWER
130' CAMCRAFT Passenger Ship. Certified for 33 passengers overnight. Booked for the season. Virtual turnkey: Money and opportunity, working PNW..... 2,200,000

100' STEEL HIGH ENDURANCE ADVENTURE/CHARTER SHIP & Business in Panama. Successful & turn-key operation and a great opportunity..... Ask 2.25 mil USD
52' GOLD COAST Coastal Cruiser, twins, F/G, two helms, ideal cruising liveboard..... Asking 38,950
50' MAKAL. Famous former Sea Scout Ship. Twins, good layout, great joy..... Ask 29,950
45' STEPHENS 1929 classic. Beautiful Gatsby-era motoryacht waiting to transport you back to the days of yachting in the grand style..... Try 75,000
44' TRAWLER by Wm. Garden. Offshore beauty by the King of trawlers. A yacht of commercial quality, best wood construction..... Asking 149,000
43' MATTHEWS, '65, diesel. A gem! Loaded and beautiful..... Asking 69,450
42' GRAND BANKS Tvl. Aft cabin, F/B, Onan, twin dsls, radar. Excellent..... 121,000
32' BOWPICKER, aluminum. Commercial (bering) license..... 49,000
32' GRAND BANKS Trawler. Classic '70 Dsl, dual helms, full electronics, TEAK decks, swim platform, economical - MORE! Ask 24,950
31' FARALLON P/H w/300 hp dsl, hydral., F&G lic., 3-axle trl, RADAR++..... Ask 49,950
31' MONTEREY BAY EXPRESS PILOTHOUSE utility, F/G, '9a1, twin 130 Yama's, trailer, USCG-documented, commercial quality gem. REDUCED! Asking 29,950
29' WELLCRAFT 2900 EXPRESS. Twin screw (not outdrives). Super clean & nice! Bright red..... REDUCED! Asking 19,950
28' CARVER. Dual steering stations. Unusually roomy for this size class, the Carvers are known for their good construction & creature comforts. Nice boat with exquisite restoration..... Asking 24,950
27' FARALLON Pilothouse, '86. F/G, twin 5L V8s, fast and seaworthy. Just detailed and very nice..... Asking 51,950
26' PACEMAKER, cabin/cruise/V8, nice!...8,500
25' Trad. Cabin Cruiser. Very nice '49 in fine shape..... 6,450/obo
24' WILSON w/hr. Twin Volvo 6 cyl. dsls, fwd cabin, end. PH, radar, depth, Lorán. Ideal commercial quality fishing/diving boat w/new paint & running gear! MORE!..... 24,500
24' COUNTER-STEM Traditional Yacht Tender/Launch with Cuddy. Copper bottom. A BEAUTY. YANMAR diesel..... 12,950/obo
19' CHRIS CRAFT Barrel-Stem Runabout. New cold-mold repl. w/itr. A beaut..... Ask 24,950



48' DUTCH CANAL BARGE by DeVries. STEEL. Unique cruising liveboard for Bay and Delta. Comfort and character. Diesel, tub, galley, fireplace, salon, convertible aft enclosure, beautiful decor, plus MORE! **Asking \$219,000**



QUINTESSENTIAL SWAN
SWAN 46 by German Frers & Nautor Swan of Finland. Beautifully appointed and absolutely fully equipped for comfort & performance cruising. Launched 1984 & total refit 2002. She's definitely ONE OF THE VERY BEST! **Ask \$345,000**

31' MONTEREY BAY EXPRESS PILOTHOUSE utility, F/G, '9a1, twin 130 Yama's, trailer, USCG-documented, commercial quality gem. REDUCED! Asking 29,950
29' WELLCRAFT 2900 EXPRESS. Twin screw (not outdrives). Super clean & nice! Bright red..... REDUCED! Asking 19,950
28' CARVER. Dual steering stations. Unusually roomy for this size class, the Carvers are known for their good construction & creature comforts. Nice boat with exquisite restoration..... Asking 24,950
27' FARALLON Pilothouse, '86. F/G, twin 5L V8s, fast and seaworthy. Just detailed and very nice..... Asking 51,950
26' PACEMAKER, cabin/cruise/V8, nice!...8,500
25' Trad. Cabin Cruiser. Very nice '49 in fine shape..... 6,450/obo
24' WILSON w/hr. Twin Volvo 6 cyl. dsls, fwd cabin, end. PH, radar, depth, Lorán. Ideal commercial quality fishing/diving boat w/new paint & running gear! MORE!..... 24,500
24' COUNTER-STEM Traditional Yacht Tender/Launch with Cuddy. Copper bottom. A BEAUTY. YANMAR diesel..... 12,950/obo
19' CHRIS CRAFT Barrel-Stem Runabout. New cold-mold repl. w/itr. A beaut..... Ask 24,950

**CALL (510) 232-7200 OR FREE (877) 444-5087
OR CALL GLENN DIRECT AT (415) 637-1181
FOR INFORMATION & INSPECTION APPOINTMENTS**



Jim Kennemore's Catalina 34 'Orion's Way' was hauled, serviced, painted and launched in 24 hours. Ready again for the season at \$33/ft!

I can, without reservation, recommend Nelson's services.

"My diver had told me around Thanksgiving that it was time, but not to worry - 'It'll make it through the weekend.' I called Nelson's and talked with one of their young front office guys, Doug Paulsen. I gave him the date I wanted it hauled (January 14), and he said it wouldn't be a problem. I live in Roseville and it's a little over 200 miles round trip to Nelson's. I asked Doug if there was any way they could have it ready the next day. He checked the schedule and told me it wouldn't be a problem.

"I showed up at the door when they opened at 8:00 on Wednesday and met with Doug, who confirmed our arrangements. He took me into the next office and introduced me to Carl Nelson, once again confirming they'd have me out by the end of the next day. I stuck around to see the boat hauled and told them I'd be back at 10:00 the next morning. When I returned Thursday morning, my boat was in the sling, the bottom painted, and the crew had 'bumped' it to paint the area under the cradle pads. By 11:30 the bill was paid and the boat was in the water and thoroughly washed down, and I headed back towards my Oakland Yacht Club berth enjoying shirt-sleeve weather the entire way.

"I can without reservation, recommend Nelson's services to any and all in the recreational boating community here in Northern California."

- Jim Kennemore

"PS: Last, but certainly not least, the \$33/ft rate was just one more serendipitous part of doing business with a great outfit."



FORCE 50, 1981

Huge, comfortable, simple and stylish.
\$129,000



54' SKALLARUD, 1961

\$46,900



46' FORMOSA PETERSON, 1981

\$125,000



WYLIE 44, 2006

Sail away from the fleet.
\$325,000

Brokerage Boats Dry Stored only \$5/ft

SAILBOATS

54' SKALLARUD, '61	49,000	26' MARIEHOLM	7,000
50' REICHEL PUGH, '94	275,000	21' HUNTER 216	16,000
49' CONCRETE KETCH	30,000	14' HUNTER 140	4,000
45' EXPLORER, '79	125,000	9' HUNTER XCITE	2,200
44' C&C, '86	150,000		
41' CORONADO, '72	19,000		
40' OLSON, '88	80,000		
37' HUNTER, '93	85,000		
37' RANGER, '74	29,000		
36' ISLANDER, '76	36,500		
35' ERICSON, '72	21,000		
34' PETERSON OOD, '79	32,500		
32' COLUMBIA SABRE, '66	6,000		
31' ISLAND PACKET, '89	39,000		
30' SANTANA	19,400		
30' CARTER, '76	19,000		
28' CAPE DORY, '77	28,000		
27' CATALINA	8,000		

POWER BOATS

57' HERMON	39,000
45' HOUSEBOAT	38,000
35' LARC, '63	90,000
34' MAINSHIP, '80	29,000
32' UNIFLITE, '76	24,400
32' BOUNTY, '00	185,000
32' BAYLINER, '90	45,000
30' REGAL	15,000
28' CARVER SEDAN, '73	25,000
19' REINELL, '77	3,500
17' CHRIS CRAFT, '59	14,999
9' CARIBE INFLATABLE, '91	2,500

NELSON Yachts

Chad Freitas, Broker
(877) 517-8281
www.nelsonyachts.net



SACRAMENTO AFFILIATE: McClellan Indoor Boat & RV Storage
(916) 640-0141 • www.mcclellanstorage.com



Nelson's Marine
www.nelsonsmarine.com

**SELL
YOUR BOAT
WITH US!**

1500 FERRY POINT
ALAMEDA, CA 94501
(510) 814-1858 • FAX (510) 769-0815