



2016 Northern California **SAILING CALENDAR** AND YRA MASTER SCHEDULE

A Complete Racing Guide

Latitude 38 Publications

Pick one up. It's **FREE!**



GO WITH



'If I could find a better rigger I'd do it. Scott Easom's dedication to getting the best out of every race boat, whether on the water as a sailor or off the water installing the most advanced and successful race rigging available, is the reason we keep coming back. The Easom team's hard work, skill and expertise keeps *Pyewacket* right where we want her - out front!' — Roy Pat Disney, owner, *Pyewacket*

World-beating rigging available on

THE BEST

If You Race To Win, Why Not Go With The Best?

There's no worse waste of time and money than a less than perfect rigging job. Easom Rigging is your world-class rigger right here on San Francisco Bay. When you race to win a well executed deck layout is as important as your well executed tack or jibe. In fact you can't have one without the other.

We engineer all your rigging right up front for safety, performance and value.

Your best value in race-winning upgrades is having Easom Rigging doing the job right the first time.



Essentially all riggers have access to the same equipment — the difference is in the installation. Easom does it best!

For a job done right, contact:



Easom Racing and Rigging

1150 Brickyard Cove Rd. Suite B1
Point Richmond, CA 94801

(510) 232-SAIL (7245)

seasom@sbcglobal.net

San Francisco Bay!



**GAIN OUT OF EVERY TACK WITH THE NEW
CARBO ONETOUCH® WINCH HANDLE**

Its full-length, quick-release bar
locks and releases one-handed.
You're locked and cranking faster.
Unlocked and back on the rail hiking
sooner. It's going to be trimmer
love at first touch.

HARKEN®

www.harken.com/Carbo-OneTouch

CONTENTS

Welcome to the YRA	6
YRA Contact Information	8
2015 Season Winners	10
Sponsoring Clubs	12
Yacht Club Alphabet Soup	14
Additional Associations	14
PHRF Committee	16
Racing Rules	18
Equipment Requirements	20
Beer Can Racing	22-25
Caribbean Circuit	26
Midwinter Series	28-29
Shorthanded Circuit	30
Fleet Schedules	32-33
Central Bay Marks	34-35
North Bay Marks	36
YRA Racing Areas	37-38
South Bay Marks	39
NCPHRF Application How-To	40-48
YRA Races	41-47
PHRF Application	49
Race Signal Flags	50
Monthly Calendar Pages	51-73
Youth Sailing	52-60
VHF Radio Channel Uses	64
Women's Circuit	68
Pacific Ocean Events	70
<i>Latitude 38</i> Contact Information	72
Sunrise/Sunset Times	72
SF Bay Current Charts	74-77
Weekend Currents	79-80
Advertisers Index/Alpha Index	82

Cover Photo: *Latitude 38* /Chris

Graphic Design: *Latitude* /Annie Bates-Winship & Colleen Young

Questions concerning the 2016 YRA Calendar should be addressed to the YRA office at (415) 771-9500 or the appropriate class association.

Check the monthly edition of *Latitude 38* and www.latitude38.com for calendar updates.

EXCEL UNDER PRESSURE

Long before the excitement of the race or the relaxation of the cruise, a lot of thought and years of experience go into making sails that are easy to trim and offer **Speed, Durability and Value.** Creating sails that deliver on all fronts demands the very best design and engineering expertise, the finest materials and construction, and the ongoing support for which Doyle is known.



Doyle San Francisco
Bill Colombo
Josh Butler
(510) 523-9411

ISLAND YACHT CLUB

Located adjacent to Svendsen's Marine
in the Alameda Marina
1853 Clement Avenue, Building 14

2016 RACING SCHEDULE

1/10, 2/14, 3/13: Estuary Midwinters Island Days

Feb 28: Sadie Hawkins Woman-Skippered Race
on the Estuary, Full Crew

Apr 2: 35th Annual Doublehanded Lightship



CHRISTINE WEAVER

Apr-Sept: Spring & Summer Twilight Series
Friday evening beer can racing

Apr-Sept: Interclub Races

June 25: Silver Eagle Long Distance Race,
Classic Course and Shortened Course

**Sept 24-25: Northern California
Women's Sailing Seminar & Regatta**
'Capture the Power', with flat water
Estuary racing on September 25

Nov 6: Jack & Jill +1 Woman-Skippered
Triplehanded Race on the Estuary

Nov 26: Commodore's Challenge

**Nov '16-
Mar '17: Estuary Midwinters Island Days**
Second Sundays of each month

• Sadie and Jack & Jill are counters in the *Latitude 38* Woman's Circuit •
Member of PICYA



For information, see www.iyc.org
racing@iyc.org
phone
(510) 521-2980

THE YRA WELCOMES YOU TO THE 2016 RACING SEASON

Welcome to the YRA's 2016 Racing Season! We've got lots of racing opportunities planned for everyone, and the best racing value on the Bay. Whether you sail a multihull, a classic woody or a one-design boat, sail on the ocean or under PHRF in the Bay, we've got races waiting for you.

This publication serves as your reminder that it's time to renew your PHRF certificate and time to sign up to race! You can renew your PHRF certificate online at www.yra.org. No form is needed for a straightforward renewal. If you have changes to make, contact the YRA office for more information. An application for a new certificate is included in this publication, along with guidelines on how to complete our application.

For 2016, the YRA Racing Season offers four different racing options:

- **YRA Spring & Summer Series:** Each is a three-day series, generally with two races scheduled each race day. Divisions for one-design boats, sportboats and PHRF boats available.
- **OYRA:** Nine ocean races are scheduled again this year, with divisions for fully crewed and shorthanded boats.
- **Wooden Boat Series:** A full schedule of in-the-Bay racing for Bears, Birds, IODs, Folkboats and Knarrs.
- **Weekend Regattas:** The Great Vallejo Race, the Westpoint Regatta, the 2nd Half Opener and the Season Closer. YRA's four marquee events with divisions for all types of racers.

You can find information on the different racing opportunities in this publication and on the YRA website. When you're ready to sign up, visit www.yra.org to enter electronically.

We encourage everyone to get a YRA membership and sign up to race. Your membership, support and participation in the YRA goes to help us do everything we do. And we do a lot:

- Administer the local PHRF database; more than 600 certificates were issued in 2015. YRA members receive discounts on PHRF fees and complimentary changes throughout the year!
- Coordinate with the U.S. Coast Guard to process event permits - more than 800 permits in 2015.
- Maintain racing buoys on the Bay.
- Host the US Sailing Area G Appeals Committee.
- Advocate for sailing and racing in the Bay Area.
- Offer great racing.

As always, we want to thank the YRA member yacht clubs and their race committees who are sponsoring this year's YRA races. We couldn't do it without you and your support. We know each YRA skipper and crew thanks you as well.

Be sure to follow us on Twitter and Facebook to keep up with all the latest YRA news. You can find us on Twitter at YRAofSFBay and on Facebook at the YRA of SF Bay page.

Get those certificates renewed and get your entries in soon! We look forward to seeing you out on the starting line for every race you're scheduled to sail.



Charles Hodgkins



Laura Muñoz

Fair winds to all,
Charles Hodgkins,
Chairman of the Board,
chairman@yra.org
Laura Paul, Executive
Director, info@yra.org

Yacht Racing Association of San Francisco Bay
1070 Marina Village Parkway, #202-G, Alameda, CA 94501
(415) 771-9500; Fax (415) 276-2378, info@yra.org; www.yra.org

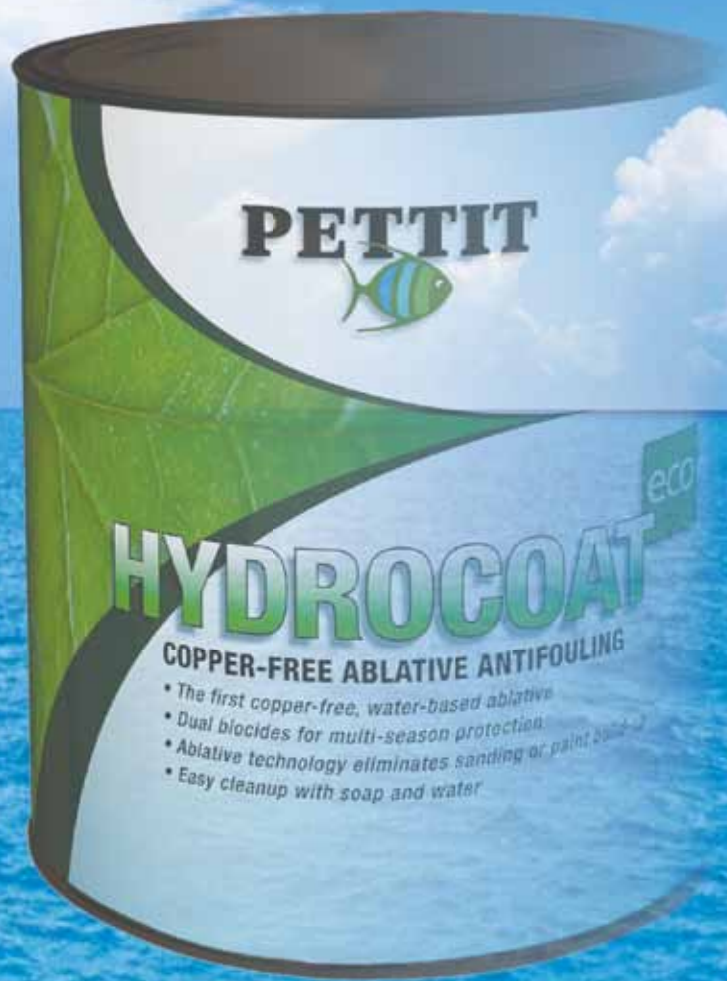

AIR AND SEA WILL NEVER KNOW.

All you sceptics who believe you can't get real fouling protection without heavy loads of copper and solvent, meet the mind changer. Hydrocoat ECO. Water-based Hydrocoat ECO is a new clean world of solvent-free antifouling. It contains the breakthrough additive Econeal that reduces copper by 100% yet delivers 100% of the copper effectiveness. It's all about maximum protection with minimum impact. It's a clean new day.



HYDROCOAT ^{eco}

Copper-Free Ablative Antifouling

pettitpaint.com • 800-221-4466



Oakland Yacht Club

**CELEBRATING
103 YEARS
Founded 1913**

2016 Racing Events

Sunday Brunch Series

January 3, January 17,
January 31,
February 7, February 21
March 6, March 20

First Gun 12:00
Brunch (9am to 1pm)
New racers always welcome.

Rites of Spring Saturday, March 12

Singlehanded, Doublehanded
and Full Crew Divisions.

Sweet Sixteen Wednesday Night Series April 27 • May 4-25 June 1-15 July 13-27 • August 3-31

First Gun 18:00
Challenging courses in protected waters.
Great food, fun and prizes at the
clubhouse afterwards.

Oktoberfest Saturday, October 1

Celebrate the spirit of Lederhosen and Drindl
in a race around Treasure Island to the
clubhouse and have beer, brats and prizes!

- Please join us on race day for a cocktail or meal
- Awards given after every race
- Guest docks available

See our website for race details and entry forms
www.oycracing.net

Sail, Motor, or Drive to OYC
N37 47.008, W122 15.096
1101 Pacific Marina, Alameda, CA 94501
Phone: (510) 522-6868
Fax: (510) 522-7378
email: oycracecom@gmail.com
Accepting new member applications.

YRA CONTACTS

BOARD OF DIRECTORS

CHAIRMAN OF THE BOARD* 2015-2016: Charles Hodgkins
Hm (510) 504-4076, chairman@yra.org

IMMEDIATE PAST CHAIRMAN* 2015-2016: Gerry Brown
Wk (408) 245-6560, mintaka.4@gmail.com

SECRETARY* 2015-2016: Bob Naber
Hm (510) 769-0309, k38bob@aol.com

TREASURER* 2015-2016: Bobbi Tosse
Hm (925) 939-9885, Fax (925) 906-9282, bobbi@jfcbat.com

EXECUTIVE DIRECTOR: Laura Muñoz
Wk (415) 771-9500, Cell (415) 994-4711,
Fax (415) 276-2378, info@yra.org

*Executive Committee

DIRECTORS AT LARGE

2015-2016 Vallejo YC Representative: (707) 643-1254, info@vyc.org

2015-2016 Corinthian YC Representative: (415) 435-4771, info@cyc.org

2016-2017 Sequoia YC Representative: (650) 361-9472, office@sequoiayc.org

2016-2017 Encinal YC Representative: (510) 522-3272, info@encinal.org

SERIES PRESIDENTS

In-the-Bay Series (Includes HDA/ODCA): Vacant

Ocean Series (OYRA): Andy Newell
(408) 391-0963, andy.newell@sbcglobal.net

Wooden Boat Series (WBRA): Robert Thalman
Hm (415) 479-3281, Fax (415) 499-8077, bobthalman@aol.com

WBRA, YRA REPRESENTATIVE: Don Wilson
Hm (510) 527-1619, windansea@sprintmail.com

COMMITTEES

BUOYS: Patrick Hind-Smith
(415) 328-2819, psman99@hotmail.com

PHRF: (415) 771-9500, phrf@yra.org
See page 16 for PHRF (Performance Handicap Racing Formula) committee.

US SAILING

DIRECTOR, AREA G: John Siegel
Hm (408) 234-0422, jasiegel@earthlink.net

AREA REGIONAL ADMINISTRATIVE JUDGE: Mike Gross, (831) 476-2054,
mike.gross@charter.net

ARO, AREA G: Nancy DeMauro
(415) 630-0002, ndemauro@hotmail.com

APPEALS COMMITTEE

John Christman, Hm (510) 797-5524, Cell (510) 410-6771,
Fax (510) 790-3273, john.christman@jc2tech.com

Mike Gross, (831) 476-2054, mike.gross@charter.net

Paul Kamen, Hm (510) 540-7968, Fax (510) 540-6324, pk@well.com

Tom Roberts, Hm/Wk (415) 898-7802, tensleyrob@aol.com

John Siegel, (408) 234-0442, jasiegel@earthlink.net

Latitude 38 has made every effort to ensure the accuracy of all information, but please confirm your schedule with your fleet captain and look in the monthly *Latitude 38* Race Calendar or on www.latitude38.com for changes. Due to space limitations, not all information could be included.

WHERE DO YOU GO FOR HIGH QUALITY BOAT REPAIR?

As the largest Coast Guard certified sailboat on the West Coast, the Bay Lady has quite a reputation to uphold. That's why, when maintenance and restoration is required, San Francisco's top charters and pleasure cruisers continually depend on the unparalleled competence of Bay Marine Boatworks.

For superior workmanship, fixed pricing and scheduled deliveries, there is only one boat yard on the West Coast.

**HELP PUT YOUR VESSEL
A CUT ABOVE THE REST**

Our mission is to guarantee absolute satisfaction to every customer.



310 West Cutting Blvd., Point Richmond, CA 94804

Tel. 510.237.0140 • Parts Tel. 510.234.7960

office@baymarineboatworks.com

www.baymarineboatworks.com

CONGRATULATIONS 2015 SEASON WINNERS

YRA Spring Series

PHRF: *Azure*, Cal 40, Rodney Pimentel, EYC

Santana 22: *Byte Size*, Anna Alderkamp, SSS

YRA Summer Series

PHRF: *Azure*, Cal 40, Rodney Pimentel, EYC

Santana 22: *Meliki*, Deb Fehr, SSS

OYRA Series

PHRO 1: *Rufless*, Melges 32, Rufus Sjoberg, RYC

PHRO 2: *Elan*, Express 37, Jack Peurach, SSS

PHRO 3: *Green Buffalo*, Cal 40, Jim Quanci, RYC

SHS: *Nancy*, Wyliecat 30, Pat Broderick, SSS

Multihulls: *Raven*, F-27, Truls Myklebust, BAMA

YRA-WBRA

Bear: *Magic*, Tim Maloney, MMBA

Bird: *Cuckoo*, Bill Claussen, RYC

Folkboat: *Polperro*, Peter Jeal, BVBC

IOD: *Bolero*, Richard & Mark Pearce, SFYC

Knarr: *Fifty/Fifty*, Brent Crawford, SFYC

SSS

Singlehanded Monohull: *Lightspeed*, Wylie 39, Rick Elkins, RYC

Singlehanded Multihull: *Tri N Fly*, F-27, David Morris, HMBYC

Doublehanded Monohull: *Outsider*, Azzura 310, Greg Nelsen, SSS

Doublehanded Multihull: *Roshambo*, Corsair 31R, Darren Doud, SSS

Small Boats

El Toro Seniors: *Hippo*, Fred Paxton, RYC

El Toro Juniors: *Raging Bull*, Trevor Foley, SCYC

Mercury: *Fast Break*, Randy Smith, SFYC

Vanguard 15: Al Sargent, StFYC

Laser: *Seaweed Magnet*, Emilio Castelli, SRSC

Laser Radial: *My Little Wife/Happy*, Stephen Aguilar, FLYC

And More...

BAMA Cup: *Ma's Rover*, Corsair F-31R, Mark Eastham, BAMA

BAMA Fast Cat: *Smart Recruiters*, Extreme 40, Jerome Ternynck, StFYC

Etechells: *Moneyball*, Blaine Pedlow, StFYC

Express 27 Championship: *Motorcycle Irene*, Will Paxton/Zachery Anderson, RYC

Express 27 Long Distance Series: *El Raton*, Ray Lotto, StFYC

Express 37: *Golden Moon*, Express 37, Kame Richards/Mike Mannix, EYC

Islander 36: *Windwalker*, Richard Shoenhair, SSS

J/24: *Downtown Uproar*, Darren Cumming

J/105: *Blackhawk*, Ryan Simmons, SFYC

J/111: *MadMen*, Dorian McKelvy, StFYC

J/120: *Peregrine*, David Halliwill, StFYC

Melges 24: *Wilco*, Doug Wilhelm, SFYC

Moore 24: *Banditos*, John Kernot, RYC

Open 5.70: *Boaty*, Ben & CJ Anderson, SSS

Wylie Wabbit: *Kwazy*, Colin Moore, RYC



SLACKWATER SF

Go get 'em in 2016!



ENCINAL YACHT CLUB PRESENTS

SUMMER SAILSTICE 2016

A Global Celebration of Sailing

SATURDAY

JUNE 18

- Sailstice Small Boat Races
- Compete in boat building contest
- Cruise in to EYC Sailstice Festival
- Music, food, activities
- Join the 'Estuary Stroll and Sleepover'

Learn more and sign up to win from over 400 prizes at

www.summersailstice.com/sf

EYC 2016 CALENDAR

JUNIOR SAILING PROGRAM

Year Round: (510) 769-0221

JACK FROST MIDWINTERS

January 23, February 27, March 19, November 12

BAYS OPTI REGATTA

February 13-14

MERCURY SERIES

March 5, April 9, May 14, June 4

SMALL BOAT SPRING & SUMMER SERIES

March 19 through September 18

FRIDAY NIGHT ESTUARY

SPRING & SUMMER TWILIGHT SERIES

April 8 through September 9

ESTUARY CUP

April 10

PCISA SILVER CHAMPIONSHIPS

April 23-24

CALIFORNIA OFFSHORE RACE WEEK

Spinnaker Cup: May 27, Coastal Cup: May 29,

In-Port Race: June 1, SoCal 300: June 3

SUMMER SAILSTICE

June 18

BAYS REGATTA

July 9-10

GRACIE & GEORGE REGATTA

August 21

MILLIMETER NATIONALS

September 10-11

COMMODORE'S CUP

September 11

BART'S BASH

September 18

JUNIOR SAILING REGATTA

October 1-2



See website for complete calendar of EYC events

Guests are invited to visit the Club, in Alameda, by land, sea or the web
ACCEPTING MEMBERSHIP APPLICATIONS

For Race, Berthing, Dining & Membership Information, call (510) 522-3272

www.encinal.org

YOU'RE INVITED

★ ALL BOATS WELCOME ★

2016 CORINTHIAN RACING:

65th Annual Midwinters:

- January 16-17
- February 20-21
- 4th Annual Rob Moore Regatta – February 20

X-Bay Friendship Regatta:

- June 4

Master Mariner's Boat Show:

- June 26

Friday Night "Beer Can" Series:

- April 15-August 26

Singlehanded Transpac Start:

- July 2 – Organizer: SSS

CYC One-Design Invitational:

J/105, Express 27, Moore 24, plus...

- July 23-24

OYRA/SSS Drake's Bay Regatta:

- August 27-28

YRA Season Closer:

- September 24-25

Sign up to enjoy great racing and great hospitality with all your favorite competitors.

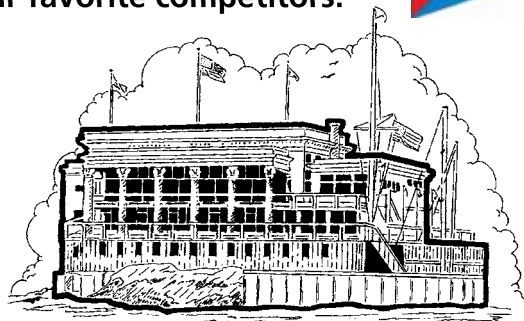

Corinthian Yacht Club

OF SAN FRANCISCO

43 MAIN, TIBURON, CA 94920 • (415) 435-4771

Visit our website: www.cyc.org

CALL TO HOST YOUR 2017 CHAMPIONSHIPS

SPONSORING CLUBS

BERKELEY YACHT CLUB (BYC) • (510) 843-9292
Bobbi Tosse c/o BYC, 1 Seawall Drive, Berkeley 94710

CORINTHIAN YACHT CLUB (CYC) • (415) 789-9206
Don Wieneke, c/o CYC, 43 Main Street, Tiburon 94920

ENCINAL YACHT CLUB (EYC) • (925) 930-0247
Jim Vickers c/o EYC, 1251 Pacific Marina, Alameda 94501

GOLDEN GATE YACHT CLUB (GGYC) • (415) 346-BOAT
Chris Childers c/o GGYC, 1 Yacht Road, San Francisco 94123

HALF MOON BAY YACHT CLUB (HMBYC) • (650) 728-2120
Steve Smith c/o HMBYC, PO Box 52, El Granada 94018

RICHMOND YACHT CLUB (RYC) • (510) 237-2821
Doug McVae c/o RYC, PO Box 70295, Pt. Richmond 94807

ST. FRANCIS YACHT CLUB (StFYC) • (415) 563-6363
Graham Biehl c/o StFYC, On the Marina, San Francisco 94123

SAN FRANCISCO YACHT CLUB (SFYC) • (415) 789-5647
Lisa Turner c/o SFYC, PO Box 379, Belvedere 94920

SAUSALITO YACHT CLUB (SYC) • (415) 331-9147
Chuck Cihak c/o SYC, PO Box 267, Sausalito 94966

SEQUOIA YACHT CLUB (SeqYC) • (650) 364-9643
Rick Dalton c/o SeqYC, 441 Seaport Court, Redwood City 94063

SOUTH BEACH YACHT CLUB (SBYC) • (650) 302-1187
Dan Courter c/o SBYC
Pier 40 On the Embarcadero, San Francisco 94107

VALLEJO YACHT CLUB (VYC) • (707) 643-1254
Dave Nadolne c/o VYC, 485 Mare Island Way, Vallejo 94590



Thanks to all yacht clubs, advertisers and race committees for their support!

FRICTION DEVICES



MXL SNATCH RINGS

Optimal Weight To Working Load Ratio

MXL soft blocks are ideal for applications where lines are under heavy semi-static loads. Featuring higher working loads than standard blocks of the same size, the MXL improves onboard performance. Used as a snatch block, it can be easily installed and removed in a few seconds. It is also a great product to keep as a spare for any emergency situation.

Model	Max Line Ø	Height	Weight oz	WL lbs
MXL6	8mm - 5/16"	35mm - 1 3/8"	.70	1,985
MXL8	10mm - 3/8"	45mm - 1 3/4"	1.41	3,086
MXL10	14mm - 9/16"	55mm - 2 5/32"	2.89	3,968



FRX RINGS

Reliability, Light Weight And Versatility

FRX Rings are ideal for applications where lines are under heavy semi-static loads, or to defect lines throughout the boat. Rigged with a soft attachment, the FRX ensures light weight and effective angle deflection for multiple applications onboard.

Model	Ø A	Ø B	WL lbs	Weight oz
FRX 6	13/16"	9/32"	881	.07
FRX 10	5/16"	3/8"	1,763	.17
FRX 15	3/8"	19/32"	3,527	.42
FRX 20	9/16"	25/32"	7,054	1.09
FRX 25	21/32"	63/64"	11,023	2.01

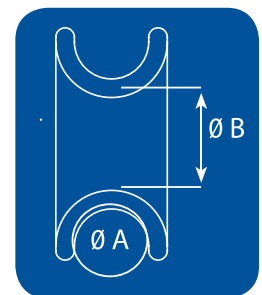
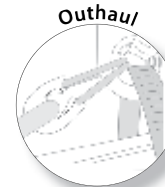

www.wichardamerica.com

Wichard Inc

Tel: +1 (401) 683-5055 | Fax: +1 (802) 655-4689 | Email: info@wichard-usa.com

Wichard
When Life Depends On It

CLIP AND SAVE! ✂

PIRATES + LAIR 2016 SAVINGS!

20% OFF—Club and Team Orders*

Save 10% off any custom yacht club or racing team order over \$100.

- Sublimated Wicking Shirts
- Embroidery
- Screen Printing

*Valid for one order per customer in 2016.

20% OFF—Online Store

Use coupon code 16LAT38 for 20% off at store.pirateslair.com. Expires 12-31-16.

Check out new merch online:

Oracle Team USA & America's Cup 2017

Official Merchandise by Sail Racing now Available!

Mount Gay® Rum new items for 2016

CLIP AND SAVE! ✂

SAIL RACING

Gill Hanes

CUTTER & BUCK

GILDAN

PORT AUTHORITY



PIRATES + LAIR

888.SAIL.BUM

WWW.PIRATESLAIR.COM

©2016 Mount Gay Distilleries Ltd., Mount Gay® Barbados Rum, 40% Alc/Vol, Imported by Remy Cointreau USA, Inc., New York, N.Y. Eclipse Design® Be Confident. Drink Responsibly.

YACHT CLUB ALPHABET SOUP

ABYC	Alamitos Bay Yacht Club	LYSA	Lake Yosemite Sailing Association
ACSC	Alameda Community Sailing Center	MBYC	Mission Bay Yacht Club
AYC*	Alameda Yacht Club	MMBA	Master Mariners Benevolent Association
AeoYC*	Aeolian Yacht Club	MPYC*	Monterey Peninsula Yacht Club
BAADS	Bay Area Association of Disabled Sailors	MYC*	Marin Yacht Club
BAMA*	Bay Area Multihull Association	NHYC	Newport Harbor Yacht Club
BBYC*	Ballena Bay Yacht Club	NOSA	Newport Ocean Sailing Association
BVBC*	Bay View Boat Club	OPYC*	Oyster Point Yacht Club
BYC*	Berkeley Yacht Club	OYC*	Oakland Yacht Club
BenYC*	Benicia Yacht Club	PCYC	Pacific Cup Yacht Club
CBYC	Cabrillo Beach YC	PICYA	Pacific Inter-Club Yacht Association
CGRA	Columbia Gorge Racing Association	PYSF	Peninsula Youth Sailing Foundation
GMA	Cal Maritime Academy	PresYC*	Presidio Yacht Club
CN	Club Nautique	RYC*	Richmond Yacht Club
CPYC*	Coyote Point Yacht Club	SBYC*	South Beach Yacht Club
CSC*	Cal Sailing Club	SCYC*	Santa Cruz Yacht Club
CYC*	Corinthian Yacht Club	SDYC	San Diego Yacht Club
CalYC	California Yacht Club	SFYC*	San Francisco Yacht Club
DSC*	Diablo Sailing Club	SJSC*	San Jose Sailing Club
EYC*	Encinal Yacht Club	SLYC	San Leandro Yacht Club
EIKYC*	Elkhorn Yacht Club	SPYC*	Sierra Point Yacht Club
EmYC*	Emeryville Yacht Club	SRYC*	San Rafael Yacht Club
FLYC*	Folsom Lake Yacht Club	SSC*	Stockton Sailing Club
FSC	Fremont Sailing Club	SSS*	Singlehanded Sailing Society
FYC*	Fresno Yacht Club	SYC*	Sausalito Yacht Club
GCYC*	Gold Country Yacht Club	SeqYC*	Sequoia Yacht Club
GGYC*	Golden Gate Yacht Club	StFYC*	Saint Francis Yacht Club
HLBC	Huntington Lake Boat Club	TISC	Treasure Island Sailing Center
HMBYC*	Half Moon Bay Yacht Club	TIYC*	Treasure Island Yacht Club
HRYC	Hood River Yacht Club	TPYC	Transpacific Yacht Club
HYC	Humboldt Yacht Club	TYC*	Tiburon Yacht Club
IYC*	Island Yacht Club	Tahoe YC*	Tahoe Yacht Club
InvYC*	Inverness Yacht Club	YYC*	Vallejo Yacht Club
LAYC	Los Angeles Yacht Club	WSC*	Whiskeytown Sailing Club
LBYC	Long Beach Yacht Club		
LGYC*	Los Gatos Yacht Club		
LMSC	Lake Merritt Sailing Club		
LTWYC*	Lake Tahoe Windjammers Yacht Club		
LWSC	Lake Washington Sailing Club		

*YRA Member Clubs

ADDITIONAL ASSOCIATIONS

- **BAADS:** Bay Area Association of Disabled Sailors (415) 281-0212, www.baads.org
- **BAMA:** Bay Area Multihull Association Bob Naber, sfbchair@sfbama.org, www.sfbama.org
- **BAYS:** Bay Area Youth Sailing www.bayarea-youthsailing.com
- **MMBA:** Master Mariners Benevolent Association (415) 364-1656, www.mastermariners.org
- **NCORC:** Northern California Ocean Racing Council www.norcalorc.org
- **PICYA:** Pacific Inter-Club Yacht Association Lynda Myers, (415) 602-9961, lyndapicya@gmail.com, www.picya.org
- **SSS:** Singlehanded Sailing Society (866) 724-5777, racechair@sfbaysss.org, www.sfbaysss.org
- **U.S. COAST GUARD** (Marine Event Permits): (415) 399-3440, Fax (415) 399-3480, www.uscg.mil
- **US Sailing:** 15 Maritime Dr., Portsmouth, RI 02871 (401) 683-0800, (800) 877-2451, info@ussailing.org, www.ussailing.org

Strictly Sail Pacific

April 7-10, 2016

Craneway Pavilion and Marina Bay Yacht Harbor



THE WEST COAST'S ONLY

All-Sail

BOAT SHOW!

MORE BOATS!

*The best selection of
brands at the best prices
in one location*

New model introductions • Daily seminars from top names in sailing
Shop and save on a huge selection in the sailing gear and accessories pavilion
FREE Sailboat rides • Live music & special entertainment for all ages

Visit StrictlySailPacific.com for tickets and show details



Find us on:
facebook.



#SSPAC16

License #0E32738

TWIN RIVERS MARINE INSURANCE

AGENCY, INC.

"Your Marine Insurance Specialists"

**7 Marina Plaza • Antioch, CA 94509
At The Antioch Marina**

Latitude 38° -01'10" N • Longitude 121° 49'10" W • Buoy 4 Red



Your
Twin Rivers
Policy Comes With
An Agent!



www.BoatInsuranceOnly.com
(800) 259-5701

Insurance made simple, affordable and effective.

Representing...



**Years of unbeatable experience to
match your needs to the right product.**

**West Coast □ Hawaii
Alaska □ Mexico
East Coast □ Pacific □ Atlantic**

PHRF COMMITTEE 2016

If you have a custom or modified sailboat, your boat may need to have its rating reviewed and assigned by the local volunteer PHRF committee. With your boat's measurements, the committee will provide a fair rating so you can quickly join the Bay Area racing scene. From evening beer can racing to offshore regattas to just about every other keelboat race on the Bay, a PHRF rating will make it easy to sign up and start sharpening your skills on the race course. You can fill out the rating form on page 49 with help from detailed instructions provided on page 40.

The YRA also wants to thank the committee members below for their tireless efforts at supporting fun, fair racing on San Francisco Bay.

Antrim, Jim

Wk (510) 223-9680, Fax (510) 262-0303,
jka@antrimdesign.com

Colombo, Bill

c/o Doyle Sails, Wk (510) 523-9411, Cell (510) 773-8015,
Fax (510) 523-9433, bcolombo@doylesails.com

Dees, Brooks

Wk (510) 691-2009, bdyd@comcast.net

Gurrola, George

Hm (510) 843-9417, ggurrola@comcast.net

Honey, Stan

Hm phone/fax (650) 328-3428, Wk (650) 961-7825,
Cell (650) 269-3428, stanhoney@msn.com

Richards, Kame

Pineapple Sails, Hm (510) 522-3109, Wk (510) 522-2200,
Fax (510) 522-7700, kame@pineapplesails.com

Sodaro, Robin

Hood Sails, Hm (415) 381-1223, Wk (415) 332-4104,
Cell (415) 279-4104, Fax (415) 332-0943, hoodsails@aol.com

Wijsen, Seadon

seadon.wijsen@northsails.com

Administrative Support: Laura Muñoz

1070 Marina Village Pkwy., #202-G, Alameda, CA 94501
Wk (415) 771-9500, Fax (415) 276-2378, phrf@yra.org



PAUL KÄMÉN



J[®]

120

Fleet #5

San Francisco



PHOTO: CHRIS RAY / WWW.PRINTROOM.COM/PRO/CRAY/VP



PHOTO: CHRIS RAY / WWW.PRINTROOM.COM/PRO/CRAY/VP

Join the most active and successful 40' one-design fleet on the West Coast!

The J/120 fleet offers competitive racing, friendly rivalries, and a challenging schedule all aboard an elegant, high-performance boat the whole family can enjoy.

For sales information visit:
www.sailcal.com

For more information and our 2015 sailing schedule visit:
www.sf-j120.com or contact **info@sf-j120.com**

PERFORMANCE MATTERS

J/Boats and Performance Brokerage



Nobody knows race boats like Sail California.

Buying or selling, we know the market for one design, ORR, PHRF, TP52, custom built... you name it!

If you're looking for a winning season, contact:

SAI California

www.sailcal.com

ALAMEDA: (510) 523-8500

Norman Davant
norman@sailcal.com

Rod Kux

rod@sailcal.com

Pat Nolan

pat@sailcal.com

SAN FRANCISCO: (415) 543-7333

Drew Harper

drew.harper@me.com

Garrett Greenhalgh

soulofsailing@gmail.com

RULES

Latitude 38's Basic Racing Guidelines

Since sailboat racing is a recreational sport, we think the number one rule should be to have fun. Beyond that, some basic guidelines help prevent collisions and ensure that racing is both fun and fair. Below is an outline of the ten basic rules which cover most racing situations. For completeness and total accuracy, refer to *Racing Rules of Sailing 2013-2016*, published by US Sailing. See www.ussailing.org/rules for details.

1. **Port tack keep clear** of starboard tack.



2. If boats are on the *same tack*, and overlapped, **the windward boat must keep clear** of the boat to leeward.
3. If boats are on the *same tack*, a boat clear astern **must keep clear** of a boat clear ahead.
4. **When tacking or jibing, keep clear** of boats on a tack.
5. **Avoid collisions.** If you have the right of way and hit the other boat, causing damage or injury, you both will be penalized.
6. **Don't obstruct.** Don't make it hard for the 'keep clear' boat to do so. (No hunting allowed.)
7. **Sail the course** prescribed. You have to round the marks in the directions specified in the Sailing Instructions and can't touch a mark.
8. **Proper Course** (same tack, within two hull lengths). If the leeward boat came from astern, leeward boat shall not sail above its own proper course during the overlap. (Remember that the windward boat still has to keep clear, even if windward is forced above what it believes is windward's proper course. Leeward still has right of way.)
9. **Give room at marks and obstructions** to yachts overlapped on the inside, except:
 - a. When the overlap did not exist before the lead boat reaches the **three-boatlength zone**.
 - b. When approaching a windward mark on opposite tack.
 - c. At a starting mark surrounded by navigable water. That is, you don't have to let a barger in at the start except to avoid collision (then protest).
10. **Acknowledge your fouls and protest those who don't.**

A free rule book comes with US Sailing membership. See www.ussailing.org.

J/105 Fleet #1

San Francisco Bay



PETER LYONS / WWW.IYONIMAGING.COM

JOIN OUR 2016 SERIES

We have a full spectrum of events from competitive to more relaxed, recreational racing.

CHAMPIONSHIP EVENTS

CYC One Design Invitational
J/Fest
Rolex Big Boat Series
Spring One Design
Spring Invitational
J/105 Series Stopover
Summer Keelboat

FINAL 2016 CALENDAR POSTED AT:
www.sfj105.org

Be a part of the largest North American J/105 Fleet
www.sfj105.org

For sales information, go to
www.sailcal.com

EQUIPMENT REQUIREMENTS FOR ALL IN-THE-BAY YRA RACES

These requirements are for races held within San Francisco Bay. Please note that OYRA races have separate requirements which can be found at www.norcalorc.org/gear.

- 1.1 These Minimum Equipment Requirements establish uniform minimum equipment and training standards for a variety of boats racing in San Francisco Bay under YRA. These regulations do not replace, but rather supplement the requirements of the U.S. Coast Guard, the Racing Rules of Sailing (RRS), the rules of Class Associations, and all applicable rating rules.
- 1.2 The safety of a boat and her crew is the sole and inescapable responsibility of the “person in charge,” as per RRS 46, who shall ensure that the boat is seaworthy and manned by an experienced crew with sufficient ability and experience to face bad weather. S/he shall be satisfied as to the soundness of hull, spars, rigging, sails and all gear. S/he shall ensure that all safety equipment is at all times properly maintained and safely stowed and that the crew knows where it is kept and how it is to be used.
- 1.3 A boat may be inspected at any time by an inspector or measurer of the Organizing Authority. If she does not comply with these regulations her entry may be rejected, or will be liable to disqualification, or such other penalty as may be prescribed by the race protest committee.
- 1.4 All equipment required shall function properly, be regularly checked, cleaned and serviced, and be of a type, size and capacity suitable for the intended use and size of the boat and the size of the crew. This equipment shall be readily accessible while underway and, when not in use, stored in such a way that deterioration is minimized.
- 1.5 A boat’s heavy items such as batteries, stoves, toolboxes, anchors, chain and internal ballast shall be secured.
- 2.1 A boat shall have a manual bilge pump of at least a 10 GPM capacity.
- 2.2 A boat shall carry a sturdy bucket of at least two gallons (8 liters) capacity with lanyards attached.
- 3.1 Each crewmember shall have a U.S. Coast Guard-approved Type III or Type V life jacket intended for small boat sailing or other active boating.
- 3.2 A boat racing between sunset and sunrise shall carry navigation lights that meet U.S. Coast Guard requirements mounted so that they will not be obscured by the sails nor be located below deck level.
- 3.3 A boat shall carry fire extinguisher(s) that meet U.S. Coast Guard requirements, when applicable.
- 3.4 A boat shall carry a sound-making device that meets U.S. Coast Guard requirements, when applicable.
- 3.6 A boat shall carry U.S. Coast Guard flares meeting day/night requirements not older than the expiration date. Alternately, non-pyrotechnic distress signals (distress flag for day, SOS light for night) which meet USCG requirements may be substituted.
- 3.7 Beginning January 1, 2015, it was required for a boat to have a throwing sock-type heaving line of 50-ft (15m) or greater of floating polypropylene line readily accessible to the cockpit.
- 3.8 A boat shall carry a U.S. Coast Guard-approved Type IV throwable device.
- 3.9 A boat shall have a VHF radio which may be handheld or fixed mount.
- 3.10 A boat shall have a magnetic compass independent of the boat’s electrical system suitable for steering at sea.
- 3.11 A boat shall have at least one means to navigate (charts, GPS) which is appropriate for the race area and the characteristics of the boat.
- 3.12 A boat shall carry one anchor, meeting the anchor manufacturer’s recommendations based on the yacht’s size, with a suitable combination of chain and line.
- 3.13 A boat shall carry a first aid kit and first aid manual suitable for the likely conditions of the passage and the number of crew aboard.
- 4.1 Annually, two-thirds of the boat’s racing crew shall practice man-overboard procedures appropriate for the boat’s size and speed. The practice shall consist of marking and returning to a position on the water, and demonstrating a method of hoisting a crewmember back on deck, or other consistent means of reboarding the crewmember.



ALPHAROPES[®]

www.alpha-ropes.com



BayRisk *Classic*

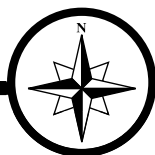

BayRisk Insurance Brokers, Inc.

800-647-2025

Visit our Website
www.bayrisk.com

1920 Minturn Street
Alameda, CA 94501

SAMSON®



For Custom Splicing
Services Please
Call or Email
Rigging@Defender.com

Warpspeed® II

Features & Benefits:

- Enhanced creep properties
- Excellent abrasion resistance
- Extremely low stretch
- High strength
- Lightweight
- Very low creep

Applications:

- Control Line
- Halyard
- Jib/Genoa Sheet
- Mainsheet
- Spinnaker Guy
- Spinnaker Sheet

MLX

Features & Benefits:

- Can be tapered
- High strength
- Lightweight
- Low stretch
- Samthane-coated core matches the cover

Applications:

- Control Line
- Halyard
- Jib/Genoa Sheet
- Mainsheet
- Spinnaker Sheet

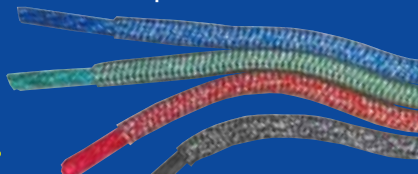

Defender®

Your Discount Outfitting Specialist!

800-628-8225 • info@defender.com

www.defender.com

WE ARE NOT
REQUIRED
TO COLLECT
SALES TAX ON
ORDERS SHIPPED
OUTSIDE OF CT

Most Orders
Placed by 4:30pm
Ship Same Day!



FREE Catalog!

2016 BEER CAN SERIES

The 2016 Beer Can Series Schedule follows. Beer can races are great venues for sailors to learn racing skills, try out new crew, bring the family, socialize, and have fun.

If your club has a beer can series you would like to list here next year, please email your schedule and contact information to colleen@latitude38.com, or fax it to (415) 383-5816, by November 12, 2016.

BALLENA BAY YACHT CLUB

Friday Night Grillers: 3/18, 4/1, 4/15, 4/29, 5/13, 5/27, 7/8, 7/22, 8/5, 8/19, 9/2, 9/16.
(510) 865-2511, race@bbyc.org, www.bbyc.org

BAY VIEW BOAT CLUB

Monday Night Madness. Spring: 4/18, 5/2, 5/16, 5/30, 6/13, 6/27 (make-up). Fall: 7/25, 8/8, 8/22, 8/29, 9/5, 9/19, 9/26 (make-up). Terry Mahoney, (408) 210-0517, tmahoney22@gmail.com, www.bayviewboatclub.org

BENICIA YACHT CLUB

Thursday Nights: 4/7-9/29. Joe Kallios, (707) 628-2914, race@beniciayachtclub.com, www.beniciayachtclub.com

BERKELEY YACHT CLUB

Every Friday Night: 4/1-9/30. Paul Kamen, (510) 540-7968, pk@well.com, www.berkeleyyc.org

CAL SAILING CLUB

Races year-round, weather and tides permitting. For members only. Check www.cal-sailing.org for specifics.

CORINTHIAN YACHT CLUB

Every Friday Night: 4/15-8/26. Don Wieneke, (415) 435-4771, racing@cyc.org, www.cyc.org

COYOTE POINT YACHT CLUB

Every Wednesday Night: 4/13-10/5. (650) 347-6730, regatta@cpyc.com, www.cpyc.com

ENCINAL YACHT CLUB

Friday Nights. Spring Twilight Series: 4/8, 4/22, 5/6, 5/20, 6/10. Summer Twilight Series: 7/8, 7/22, 8/5, 8/19, 9/9. Darrell Powell Ford, (510) 502-8110, darrellpowellford@gmail.com, www.encinal.org

continued on page 24

Boat & Yacht Insurance

Call NOW for a money saving new quote



Since 1959
www.marinersins.com
Ins. Lic. #0D36887



In the Bay Area Contact
Carolyn Pounds
(800) 992-4443 ext. 112
(510) 254-3689
carolyn@marinersins.com

Newport Beach, CA San Francisco, CA San Diego, CA Seattle, WA Bradenton, FL

Colligo Dux™ Synthetic Standing Rigging

Less Weight = More Speed!

- 1/6 the weight of stainless systems
- Stretch equivalent systems to wire/rod/aramid
- Easily spliceable/repairable
- Lashing or turnbuckle tensioning available
- Similar costs to wire!
- **New! Synthetic Lifeline Kits**, now approved by ISAF and US Sailing for offshore racing



Colligo Dux Lifelines

www.colligomarine.com

(480)
703-3675



Rigging Reduced to its
Elegant Essentials

Colligo Marine®

info@colligomarine.com



John Rivlin, Express 27 Peaches

Custom Racing, Custom Cruising, One-Design.
We have a product to fit your needs.

Ullman Sails San Francisco & Monterey Bay

104 Bronson St. #20, Santa Cruz, CA
831.454.0868
dhodges@ullmansails.com

Robin Sodaro
415.332.4117
rsodaro@ullmansanfrancisco.com

Synthia Petroka
510.205.9412

2016 BEER CAN SERIES

continued from page 22

FOLSOM LAKE YACHT CLUB

Wednesday Nights: 5/4-8/31.
Summer Sunset Series: 5/13, 6/10, 7/22, 8/5.
(916) 534-8458, www.flyc.org

GOLDEN GATE YACHT CLUB

Friday Nights: 5/6, 5/20, 6/3, 6/17, 7/1, 7/15,
7/29, 8/12, 8/26.
Dennis Bush, (510) 703-5779,
bush.sailing@gmail.com, www.ggyc.com

ISLAND YACHT CLUB

Friday Nights.
Spring Twilight: 4/15, 4/29, 5/13, 6/3, 6/17.
Summer Twilight: 7/15, 7/29, 8/12, 8/26, 9/16.
John New, (510) 521-2980,
iyrcracing@yahoo.com, www.iyc.org

KONOCTI BAY SAILING CLUB

Old Salts in Retirement,
every Wednesday at noon, year 'round.
www.kbsail.com

LAKE TAHOE WINDJAMMERS YACHT CLUB

Wednesday Nights: 5/18-10/5.
David Young, (530) 545-9155,
ltwyc2@aol.com, www.tahoewindjammers.com

LAKE WASHINGTON SAILING CLUB

Every Thursday Night: May-August.
www.lwsailing.org

LAKE YOSEMITE SAILING ASSOCIATION

Every Thursday Night: May-September.
Dennis Wainwright, (209) 722-1947,
speedyw1955@yahoo.com,
www.lakeyosemitesailing.org

MONTEREY PENINSULA YACHT CLUB

Wednesday nights: Sunset Series late September-March.
John Feeley, race@mpyc.org,
www.mpyc.org

OAKLAND YACHT CLUB

Sweet 16 Series.
Every Wednesday Night: 4/27-6/15 & 7/13-8/31.
Jim Hild, (510) 277-4676,
oycracecom@gmail.com,
www.oaklandyachtclub.com

RICHMOND YACHT CLUB

Wednesday Nights: 4/6, 4/20, 4/27, 5/4, 5/18, 5/25,
6/1, 6/8, 6/15, 6/22, 6/29, 7/6, 7/13, 7/20, 7/27,
8/3, 8/17, 8/24, 8/31, 9/7, 9/21, 9/28.
Eric Arens, (510) 841-6022,
saucierimages@comcast.net,
www.richmondyc.org

ST. FRANCIS YACHT CLUB

Wednesday Night Series: 4/27, 5/4, 5/11, 5/18, 5/25,
6/1, 6/8, 6/15, 6/22, 6/29, 8/3, 8/10, 8/17, 8/24.
J/22 Spring Series, Wednesday Nights: 3/16, 3/23,
4/6, 4/13, 4/20.
J/22 Summer Series: 7/6, 7/13, 7/20, 7/27.
Graham Biehl, (415) 655-7756,
gbiehl@stfyc.com, www.stfyc.com

SANTA CRUZ YACHT CLUB

Wet Wednesdays, every Wednesday Night: 3/16-10/26.
(831) 425-0690, scyc@scyc.org,
www.scyc.org



FRED FAGO

SAUSALITO YACHT CLUB

Tuesday Nights.

Spring Sunset Series: 4/26, 5/10, 5/24, 6/7, 6/21.

Summer Sunset Series: 7/26, 8/9, 8/23, 9/6, 9/20.

Chuck Cihak, race@sausalityachtclub.org,

www.sausalityachtclub.org

SEQUOIA YACHT CLUB

Every Wednesday Night: 4/13-10/5.

Rick Dalton, (650) 255-5766,

sviowa@gmail.com,

www.sequoiayc.org

SOUTH BEACH YACHT CLUB

Friday Night Series: 4/15, 4/22, 4/29,

5/6, 5/20, 5/27, 6/3, 6/17, 6/24,

7/15, 7/22, 7/29, 8/5, 8/19, 8/26.

Dan Courter, (925) 209-3081,

rearcommodore@southbeachyachtclub.org,

www.southbeachyachtclub.org

STOCKTON SAILING CLUB

Every Wednesday Night: 6/1-8/24.

(209) 951-5600, regatta16@stocktonsc.org,

www.stocktonsc.org

TAHOE YACHT CLUB

Monday Nights: Laser Series, May-August.

Wednesday Night: Beer Can Series, May-August.

www.tahoeyc.com

TIBURON YACHT CLUB

Every Friday Night: 5/20-8/19.

race@tyc.org, www.tyc.org

VALLEJO YACHT CLUB

Every Wednesday Night: 4/6-9/28.

Dave Nadolne, (925) 580-1499

fleetcaptainsail@vyc.org,

www.vyc.org



**HANSEN RIGGING DELIVERS
FOR OFFSHORE AND INSHORE
RACE RESULTS**

HANSEN RACE RIGGING SERVICES:

Design installation and fine tuning of all race-winning spars, hardware and cordage.

- Masts
- Booms
- Poles
- Deck hardware
- Running rigging
- Installation
- Fabrication
- Custom carbon fiber
- Standing rigging
- Lifelines
- Sheets/halyards
- Ergonomic design
- Weight reduction
- Custom hardware
- Rig pull/restep

HANSEN RIGGING

2307 Blanding Ave., Alameda

(510) 521-7027

hansenrig@sbcglobal.net



www.hansenrigging.com

NEW



OPENING PRE-FEEDER

The new Schaefer opening pre-feeders solve many issues on the bow of any racing sailboat. Our two sizes cover boats in all ranges. The 45-06 is our non-adjustable opening pre-feeder with a computer machined finish for a smooth entry. The single pull opening feature allows for quick disengagement. Our 45-07 Grand Prix design allows the flexibility to adjust for various luff tape sizes from #5 through #8.

SCHAEFER
LEGENDARY STRENGTH

508.995.9511
SCHAEFERMARINE.COM

WATERAT SAILING EQUIPMENT

- One design & offshore rudders & shafts
 - Dinghy centerboards & rudders
 - Custom structural composites

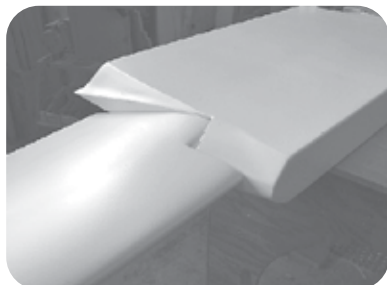
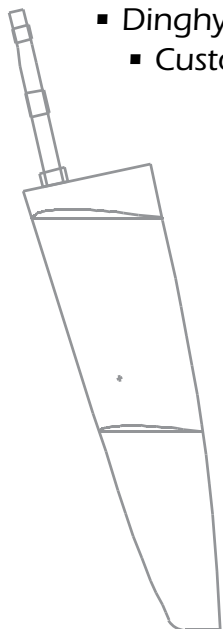

831-768-1520
e-mail: larry@waterat.com
565 McQuaide Dr. La Selva Beach, CA 95076

2016 CARIBBEAN CIRCUIT

MOUNT GAY ROUND BARBADOS RACE SERIES

January 16-24 • Barbados
www.mountgayroundbarbadosrace.com

ANTIGUA SUPERYACHT CHALLENGE

January 28-31 • Antigua
www.superyachtchallengeantigua.com

GRENADA SAILING WEEK

January 28-February 2 • Grenada
www.grenadasailingweek.com
Festival: January 30-31
(473) 456-0914, www.grenadasailingfestival.com

CONCH REPUBLIC CUP

January 28-February 6 • Key West/Cuba
www.conchrepubliccup.com

ROUND REDONDA RACE

February 16 • Antigua
www.abma.ag

ANTIGUA 360 RTI RACE

February 20 • Antigua
www.antiguayachtclub.com

RORC CARIBBEAN 600

February 22-26 • Antigua
www.caribbean600.rorc.org

ST. MAARTEN HEINEKEN REGATTA

March 3-6 • St. Maarten
Gill Commodore's Cup: March 3
(721) 544-2079, www.heinekenregatta.com

LORO PIANA CARIBBEAN SUPERYACHT REGATTA

March 9-12 • BVI
www.loropianacaribbeansuperyachtregatta.com

ST. BARTHS BUCKET REGATTA

March 17-20 • St. Barths, FWI
(781) 639-0203, www.bucketregattas.com

ST. THOMAS INTERNATIONAL REGATTA

March 23-27 • St. Thomas, USVI
(340) 998-3650 or (340) 774-2736
www.stthomasinternationalregatta.com

BEQUIA HEINEKEN EASTER REGATTA

March 24-28 • Bequia
(784) 457-3649, www.begos.com/easterregatta

BVI SPRING REGATTA AND SAILING FESTIVAL

March 28-April 3 • BVI
(284) 541-6732, www.bvispringregatta.org

MAXI YACHT ROLEX CARIBBEAN CUP

April 4-9 • Virgin Gorda
www.yccs.it

LES VOILES DE SAINT BARTH

April 11-16 • St. Barth
(590) 90 27 20 64, www.lesvoilesdesaintbarth.com

ANTIGUA CLASSICS REGATTA

April 13-19 • Antigua Yacht Club
Ph/Fax (268) 460-1799, www.antiguaclassics.com

ANTIGUA SAILING WEEK

April 22-30 • Antigua
(268) 734-6636, www.sailingweek.com

PEARNS POINT ROUND ANTIGUA RACE

April 23 • Antigua
www.abma.ag

ST. BARTH WEST INDIES REGATTA

April 28-May 1 • St. Barth
(268) 724-4435, www.westindiesregatta.com

FOXY'S WOODEN BOAT REGATTA

May 2016 • Jost Van Dyke, BVI
(284) 495-9258, www.foxysbar.com/woodenboatregatta

PUERTO RICO HEINEKEN INTERNATIONAL REGATTA

May 2016 • Puerto Rico
(787) 277-5936, www.heinekenregattapr.com

DRY CREEK VINEYARD PRO-AM REGATTA

October 2016 • Bitter End Yacht Club, BVI
(800) 872-2392, www.beyc.com

RACE THE WORLD WITH SUNSAIL



Here at Sunsail we're ready to send some charterers home with a trophy or two. Our 2016 Regatta season is about to kick off in the Caribbean and we are prepared with the most competitive global bareboat fleet to charter.

From the BVI Spring Regatta to the UK's famous Cowes Week, we'll provide all you need to take line honors at the most iconic and exotic regattas the globe has to offer.

CARIBBEAN:

Grenada Sailing Week	January 28 - February 2
Heineken Regatta	March 3 - 6
St. Thomas International Regatta	March 25 - 27
BVI Spring Regatta	March 28 - April 3
Antigua Sailing Week	April 22 - April 29



PACIFIC:

Tahiti Pearl Regatta	May 2 - May 7
Hamilton Island Race Week	August 20 - 27

UK:

Cowes Week	August 6 - 13
------------	---------------

SEE THE WORLD, DIFFERENTLY.
877.788.0496 WWW.SUNSAIL.COM/YACHT-RACING



2016 MIDWINTER SERIES

If your organization has a midwinter series you'd like included here next year, email your schedule and contact information to colleen@latitude38.com, or fax it to (415) 383-5816, by November 12, 2016.

BAY VIEW BOAT CLUB

Midwinters. Second Saturday, October-March.
Remaining 2015-2016 season: 1/9, 2/13, 3/12.
Terry Mahoney, (408) 210-0517, tmahoney22@gmail.com,
www.bayviewboatclub.org

BERKELEY YACHT CLUB

Midwinters, remaining 2015-2016 season: 1/9, 1/10, 2/13, 2/14.
Fall 2016 dates: 11/12, 11/13, 12/10, 12/11.
Bobbi Tosse, (925) 939-9885, bobbi_john@jfcbat.com
Chowder Series, remaining 2015-16 season: 1/3, 1/17, 1/24,
1/31, 2/7, 2/21, 2/28, 3/6, 3/13, 3/20, 3/27.
Fall 2016 dates: 10/2, 10/9, 10/16, 10/23, 10/30, 11/6, 11/20,
11/27, 12/4, 12/18, 12/25. Paul Kamen, (510) 540-7968,
pk@well.com, www.berkeleyyc.org

CORINTHIAN YACHT CLUB

Midwinters: 1/16-17, 2/20 (Rob Moore Memorial Regatta), 2/21.
Don Wieneke, (415) 435-4771, racing@cyc.org, www.cyc.org

ELKHORN YACHT CLUB

Frostbite Series: 2/27, 3/12, 3/26, 4/9, 4/23.
Chowder Cup Series: 10/8, 10/22, 11/5, 11/19, 12/3.
(831) 724-3875, eyc@elkhornyc.com, www.elkhornyc.com

ENCINAL YACHT CLUB

Jack Frost Midwinters, remaining 2015-2016 season:
1/23, 2/27, 3/19. Fall 2016: 11/12.
Doug Perry, (510) 867-8064, svchoices@att.net,
www.encinal.org

GOLDEN GATE YACHT CLUB

Midwinters, remaining 2015-2016 season: 1/2, 2/6, 3/5.
Fall 2016: 11/5, 12/3.
Dennis Bush, (510) 703-5779, bush.sailing@gmail.com,
www.ggyc.org

ISLAND YACHT CLUB

Midwinters, remaining 2015-2016 season: 1/10, 2/14, 3/13.
Fall 2016: 11/13, 12/11. John New, (510) 521-2980,
iycracing@yahoo.com, www.iyc.org

MONTEREY PENINSULA YACHT CLUB

Perry Cup Midwinters; remaining 2015-2016 season: 1/2, 2/6.
race@mpyc.org, www.mpyc.org

OAKLAND YACHT CLUB

Sunday Brunch Series: 1/3, 1/17, 1/31, 2/7, 2/21, 3/6, 3/20.
Jim Hild, (510) 277-4676,
oycracecom@gmail.com, www.oaklandyachtclub.com



Come on up and enjoy the
52nd Annual
Memorial Regatta
May 28 & 29, 2016
Whiskeytown Sailing Club
Whiskeytown Lake, Redding, CA

All Fleets Are Welcome –
Dinghies • Centerboard • Multihull • Keel boats

*“Good Racing, Fresh Water, Great Food and
Lots of Good People.”*

Entry or information:
www.whiskeytownsailing.org
(530) 539-4471
whiskeytownsailing@gmail.com

Bay Area Contact:
PRO John Super (415) 564-4779 • johnhsuper@att.net

Membership info on WSC web site. WSC is a Member Club of SF-YRA



**FILL YOUR COCKPIT
WITH FRIENDS**

at Latitude 38's
Spring Crew List Party
Wednesday, March 9, 6-9 pm
Golden Gate Yacht Club
details and free online crew list at
www.latitude38.com

2016 MIDWINTER SERIES

REGATTA PRO

Winter One Design Series,
remaining 2015-2016 season: 1/9, 2/13.
Jeff Zarwell, (415) 595-8364, jzarwell@regattapro.com,
info@regattapro.com, www.regattapro.com

RICHMOND YACHT CLUB

Opti Midwinters, remaining 2015-2016 season: 1/2, 2/6.
Fall 2016: 12/3. Dan Brandt, dan.higherfastervmg@gmail.com
Small Boat Midwinters, remaining 2015-2016 season: 1/3, 2/7,
3/6. Fall 2016: 12/4.
Nancy Pettengill, nancyepettengill@comcast.net,
www.richmondyc.org

SANTA CRUZ YACHT CLUB

Midwinters, remaining 2015-2016 season: 1/16, 2/20, 3/19.
Fall 2016: 11/19, 12/17.
scyc@scyc.org, www.scyc.org

SANTA ROSA SAILING CLUB

Spring Lake Winter Series, remaining 2015-2016 dates: 1/16,
2/13, 3/19, 4/16.
www.santarosasailingclub.org

SAUSALITO YACHT CLUB

Midwinters, remaining 2015-2016 season: 1/3, 2/7, 3/6.
Fall 2016: 11/6, 12/4.
Chuck Cihak, race@sausalitoyachtclub.org,
www.sausalitoyc.org

SEQUOIA YACHT CLUB

Winter Series, remaining 2015-2016 season: 1/9, 2/6,
3/19 (St. Patrick's Day Race).
Fall 2016: 11/5, 12/3.
Redwood Cup, remaining 2015-2016 season: 1/23, 2/20, 3/12.
Fall 2016: 11/19, 12/17.
Rick Dalton, (650) 255-5766, sviowa@gmail.com,
www.sequoiayc.org

SOUTH BEACH YACHT CLUB

Island Fever Series, remaining 2015-2016 season:
1/23, 2/27, 3/19. Fall 2016: 11/19, 12/17.
Dan Courter, (925) 209-3081,
rearcommodore@southbeachyachtclub.org,
www.southbeachyachtclub.org

TIBURON YACHT CLUB

Midwinters: 1/9, 2/6, 3/5.
race@tyc.org, www.tyc.org

VALLEJO YACHT CLUB

Tiny Robbins Midwinters,
remaining 2015-2016 season: 1/2, 2/6, 3/5.
Dave Nadolne, (925) 580-1499,
fleetcaptainsail@vyc.org, www.vyc.org

AIRX
SPINNAKER FABRICS

watt&sea

PLASTIMO

YALE CORDAGE

Italwinch
BY ORFVA

The Best in Top
Quality Marine
Products.
Since 1917.



BAINBRIDGE
INTERNATIONAL
www.bainbridgeintcatalogs.com

15242 Transistor Lane
Huntington Beach, CA 92649
Tel: (800) 433-0101

2016 RACE DECK SCHEDULE

45th Annual Manuel Fagundes

SEAWEED SOUP REGATTA

January 2, February 6
March 5

FRIDAY NIGHT BEER CAN SERIES

May 6, May 20
June 3, June 17
July 1, July 15, July 29
August 12, August 26

46th Annual Manuel Fagundes

SEAWEED SOUP REGATTA

November 5 & December 3

**Join us for these fun-filled races,
and enjoy the greatest view at
the friendliest club on the Bay!**

GOLDEN GATE YACHT CLUB

1 Yacht Road, San Francisco, CA 94123
(415) 346-2628
www.ggyc.org

2016 SHORTHANDED CIRCUIT

The OYRA Series and YRA Weekend Regattas have Shorthanded Divisions. Go to www.yra.org for details. Sequoia YC has a shorthanded series for local racers. The Singlehanded Sailing Society hosts seven local regattas and the Singlehanded TransPac in even years.

Jan. 30	Three Bridge Fiasco, SSS
Feb. 27	Single/Doublehanded #1, SeqYC
March 12	Rites of Spring Race, OYC
March 12	Doublehanded Long Distance, SSC
March 19	Corinthian Race, SSS
March 26	Doublehanded Farallones, BAMA
April 2	Doublehanded Lightship Race, IYC
April 16	YRA OYRA Lightship
April 23	Round the Rocks, SSS
Apr. 30-May 1	YRA Great Vallejo Race
May 7	Single/Doublehanded #2, SeqYC
May 14	Singlehanded Farallones Race, SSS
May 21	YRA OYRA Duxship
May 27	Spinnaker Cup to Monterey, SFYC/MPYC
June 11	YRA OYRA Farallones Race
June 24	Doublehanded Races, LTWYC
June 25	YRA OYRA Half Moon Bay Race
July 9	YRA Westpoint Regatta
July 16	YRA OYRA Jr. Waterhouse
July 16	Jack and Jill Race, SSC
July 23	Single/Doublehanded #3, SeqYC
July 30-31	YRA Second Half Opener
Aug. 6	YRA OYRA RC's Choice
Aug. 21	Singlehanded Race, LTWYC
Aug. 21	Gracie & George Race, EYC
Aug. 27-28	YRA OYRA / SSS Drake's Bay Race
Sept. TBD	Jack and Jill Regatta, SCYC
Sept. 10	Single/Doublehanded #4, SeqYC
Sept. 24	Half Moon Bay Race, SSS
Sept. 24-25	YRA Season Closer
Oct. 1	Shorthanded Races, TYC
Oct. 8	YRA OYRA RC's Choice
Oct. 15	Single/Doublehanded #5, SeqYC
Oct. 22-23	Vallejo 1-2, SSS
Nov. 6	Jack & Jill + 1 Race (Triplehanded), IYC

Use the Autopilot Favored by Singlehanded Racers

**For over 40 Years, ALPHA PILOTS
Have Delivered the Highest Performance,
Reliability and Low Power Consumption
These Competitors Demand!**



Photo by Robbie Gabriel

Overall Winner 2012 Singlehanded TransPac

Jim Quanci, after placing 1st Overall in the 2012 Singlehanded TransPac in his Cal 40 *Green Buffalo* says:

"Thirteen days from San Francisco to Hawaii alone, 10 of those days flying the spinnaker in winds up to 32 knots without a round up or a wrap. My Alpha Spectra autopilot drove the whole way – and then drove the boat another 16 days taking us home. What more can one ask for? I just love my Alpha Spectra autopilot."

Why buy an Alpha Autopilot? We'll make your boating more fun!

A WORLD CLASS PRODUCT PROUDLY BUILT IN THE USA

ALPHA MARINE SYSTEMS, INC., 6809 96th Avenue SE, Mercer Island, WA 98040 • (800) 257-4225 (206) 275-1200
email sales@alphamarinesystems.com Visit our website www.alphamarinesystems.com



HEAD SOUTH FOR RACING IN 2016

Join Us at the Sequoia Yacht Club

**ISLAND TIME
PARTY**
Tropical Music, Food & Fun!
Following the
Westpoint Regatta
Saturday, July 9

**WESTPOINT
REGATTA**

Saturday, July 9

One of the YRA
Weekend Regattas

MOONLIGHT MARATHON

Saturday, August 20

**SOUTH BAY
CHAMPIONSHIP**

Saturday, October 22



Also join us for these races: Redwood Cup Series • Winter Series • Single/Doublehanded Series • Summer Series
Hannig Cup (Part of Wednesday Night Beer Can Series) • Barth Race • Corkscrew Slough Regatta (El Toro Fleet)

For more information go to: www.sequoiayc.org

2016 FLEET SCHEDULES

Sailing Instructions for all YRA regattas and races will be posted on www.yra.org, the YRA website. Sailing Instructions are available one week prior to the start of each race.

Racers entering an ocean race or an ocean series must comply with the specific OYRA Minimum Equipment Requirements, including the requirement for a 406 EPIRB or PLB. No later than the Thursday before EACH race, sailors must complete the online Boat and Crew Registration form through www.jibaset.net. Please refer to www.yra.org/OYRA/ocean_safety.html for more information on ocean racing requirements.

Single Race Entries are due by 5:00 p.m. the Monday prior to the race. Entries received after 5:00 p.m. Monday may incur a \$35 late fee. Entries are not accepted after 5:00 p.m. the Thursday prior to the race.

DIMENSION-POLYANT

The Sailcloth Producer



For over 50 years DIMENSION-POLYANT has been committed to

IN-HOUSE MANUFACTURING In Germany and USA
QUALITY AND INNOVATION Continuous research and adherence to the highest standards
RELIABILITY World-wide, Sailors and Sailmakers trust in DIMENSION-POLYANT.

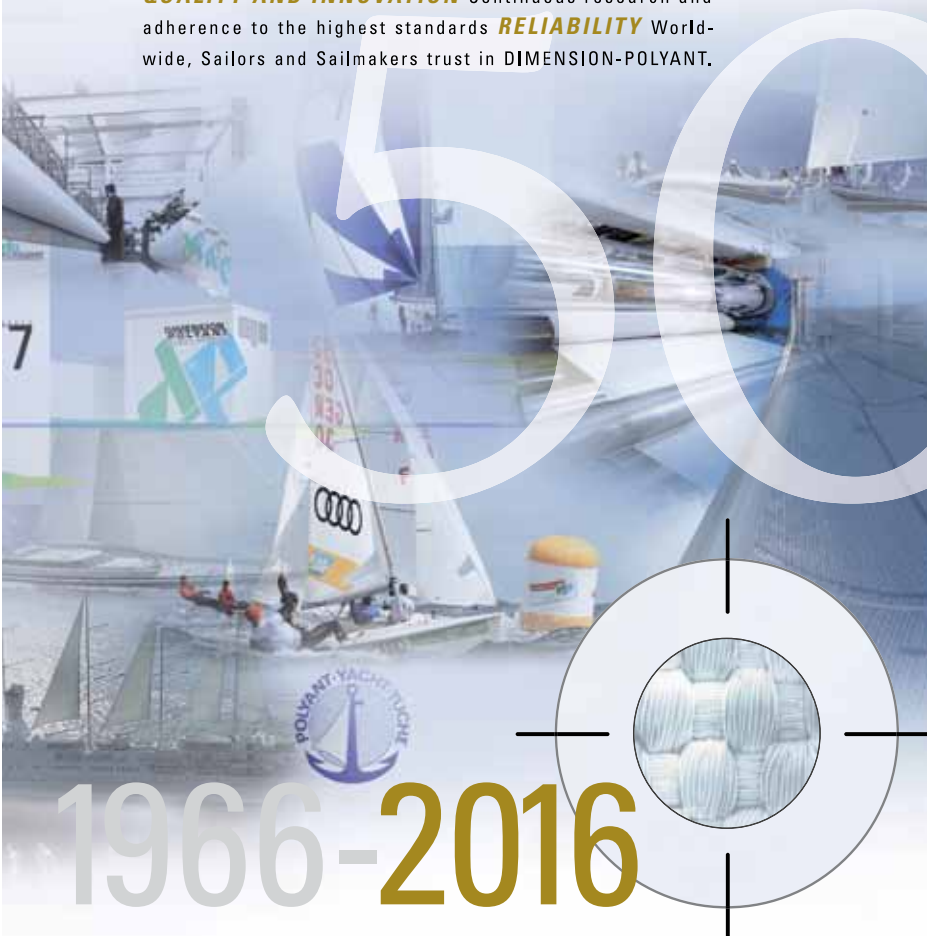

DIMENSION-POLYANT GmbH • Speelfeld 7 • 47906 Kempen • Germany • Tel. +49 21 52 8910 • dimension-polyant.com

YRA Spring Series

For PHRF, Sportboat and One Design. *Notices of Race for all YRA Series can be found on the YRA website, www.yra.org.*

- | | |
|----------|----------------------|
| April 9: | YRA Spring Series #1 |
| May 14: | YRA Spring Series #2 |
| June 18: | YRA Spring Series #3 |

YRA Summer Series

- | | |
|---------------|----------------------|
| July 23: | YRA Summer Series #1 |
| August 13: | YRA Summer Series #2 |
| September 17: | YRA Summer Series #3 |

OYRA Series

- | | |
|-----------|-------------------------------|
| April 16: | OYRA Lightship |
| May 21: | OYRA Duxship |
| June 11: | OYRA Farallones |
| June 25: | OYRA One Way to Half Moon Bay |
| July 16: | OYRA Junior Waterhouse |
| August 6: | OYRA RC's Choice |

2016 FLEET SCHEDULES

OYRA Series (cont'd)

August 27-28: OYRA Drake's Bay
 September 10: OYRA RC's Choice

YRA-WBRA Series

April 23: WBRA #1
 May 7: WBRA #2
 June 4: WBRA #3
 August 6: WBRA #4
 September 24: WBRA #5
 October 8: WBRA #6

YRA WEEKEND REGATTAS

April 30-May 1: Season Opener:
 The Great Vallejo Race
 July 9: Westpoint Regatta
 July 30-31: Second Half Opener
 September 24-25: Season Closer

SSS

See ad on page 69.

January 30: Three Bridge Fiasco
 March 19: Corinthian Race
 April 23: Round the Rocks
 May 14: Singlehanded Farallones
 July 2: Singlehanded TransPac Start
 August 27-28: Drake's Bay Race
 September 24: Half Moon Bay Race
 October 22-23: Vallejo 1-2

Notices of Race for all YRA Series
 can be found on the YRA website,
www.yra.org.

Put the smooth back in sailing

SAILKOTE™
HIGH-PERFORMANCE DRY LUBRICANT
 Use on sliding hatches, sail tracks, sails, battens, telltales, slider cars and more

- Repels water, dirt, salt, and contaminants
- Reduces drag and increases efficiency
- Clean, dry, and easy-to-use

ANTIFOUL ALTERNATIVE™
ENVIRONMENTALLY FRIENDLY ANTIFOUL POLISH
 Use on hulls, outdrives, and propellers

- Helps prevent below-the-waterline marine growth and slime from adhering for weeks
- Reduces drag and increases efficiency
- Biodegradable, non-metallic, non-leaching

HULLKOTE™
HIGH-PERFORMANCE SPEED POLISH
 Use on fiberglass, metal, plexiglass, and painted surfaces

- High-gloss finish that cleans, polishes, and protects
- Reduces drag and repels water
- Superior UV protection



For Everything
That Slides



For Everything
Below the Waterline



For Everything
That Shines



For Everything
That Rolls

With these products from Team McLube™

Team McLube™

Learn more at: WWW.MCLUBEMARINE.COM



CENTRAL BAY MARKS

Brought to you by
Latitude 38's
Latitude 38's 3x/week blog



- Racing Wrap-Ups
- Action Photos
- Racing Previews
- Free Subscription



visit
www.latitude38.com

DESCRIPTION OF MARKS

Buoys of Berkeley Circle: BOC, COC, EOC, FOC, GOC, XOC

YRA Mark XOC has been designated the *Bob Klein Memorial Buoy* by the YRA Board of Directors. Maintenance of this buoy is funded by the Richmond Yacht Club Foundation.

A: Yellow sphere "A" Outer Buoy ~ St. Francis Yacht Club

D: G "3" Fl G 4s 15 ft on Olympic Circle

K: Temporary YC buoy .3 nm west of YRA 4 and in line with YRA 12

L: Temporary YC buoy .31 nm west of windmill in line with YRA 4

N: Daymark "2" Fl R on channel east of Sausalito

X: Yellow sphere "X" ~ Golden Gate Yacht Club

1: Red Rock Island

2: Alcatraz Island

3: Farallones Light (ocean)

4: Temporary YC buoy WSW of Pt. Knox

5: Temporary YC buoy approx. .6 nm SW of Alcatraz

6: Yellow Column "M" 200 yds. north of Ft. Mason Docks

7: R "2" Fl 6s 1 nm NW of Treasure Island

8: R "4" Fl 4s Horn 1 nm east of Pt. Blunt

9: Temp. YC buoy .5 nm ESE of west end of Berkeley Pier ruins 1 nm ENE of YRA 10

10: Temporary YC buoy approx. .6 nm ESE of west end of Berkeley Pier ruins

11: Temporary YC buoy 1.5 nm east of Treasure Island

12: G "1" Fl G 4s Little Harding Rock

13: Crissy Field Buoy

14: Southampton Shoals



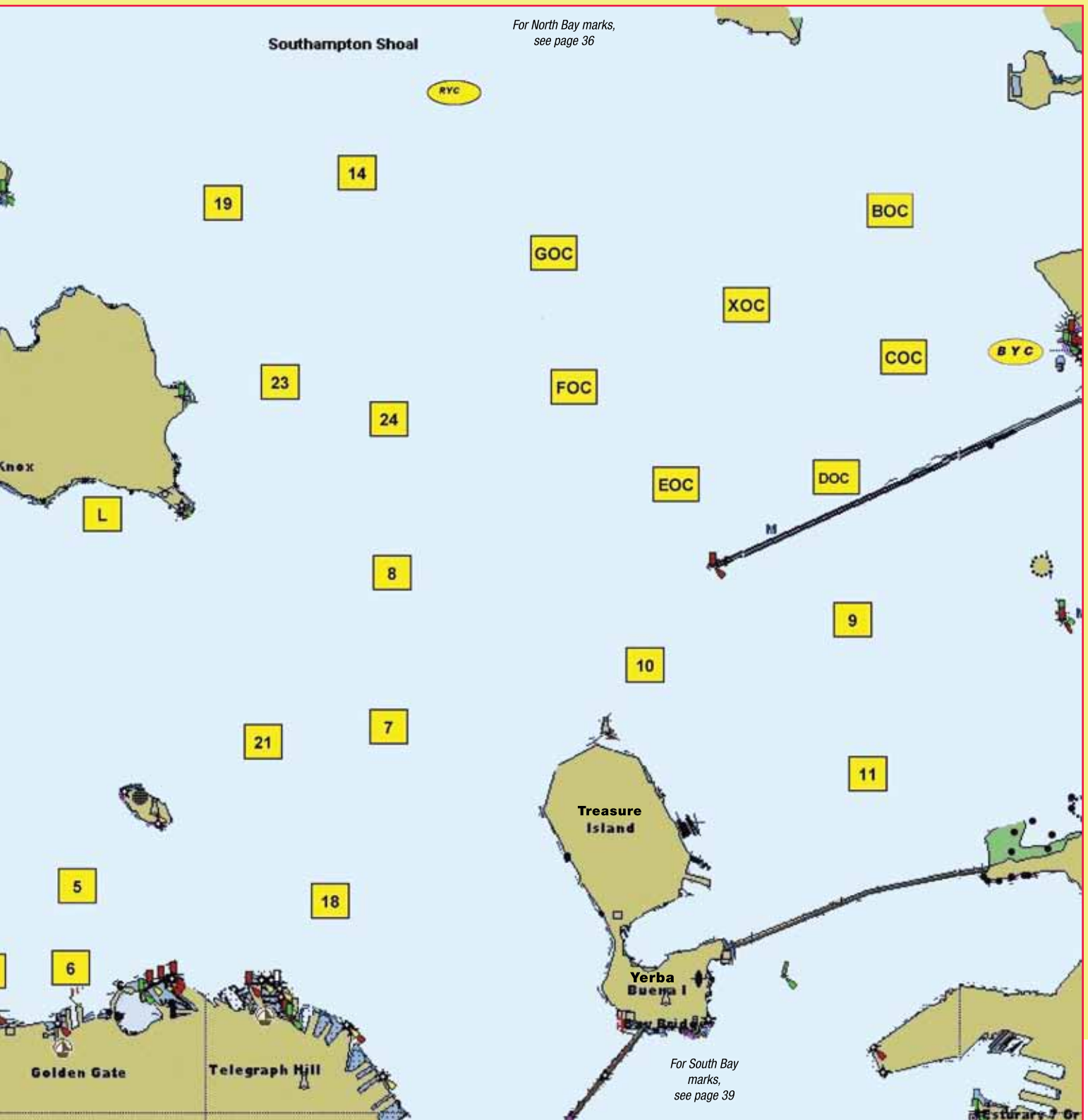

For North Bay marks,
see page 36

For South Bay
marks,
see page 39

- 15: Temporary YC buoy approx. .5 nm east of Yellow Bluff (Sausalito vicinity)
- 16: Yellow Column "C" .2 nm east of Fort Point "Blackaller"
YRA Mark 16 has been designated the *Thomas D. Blackaller Jr. Memorial Buoy* by the YRA Board of Directors. The maintenance of this buoy will be funded by the Thomas D. Blackaller Jr. Fund.
- 17: RG "HR" FI (2+1) R 6s, Harding Rock
- 18: RG "BR" FI (2+1) G 6s bell, Blossom Rock
- 19: R "8" FI R 2.5s approx. 1.5 nm east of Pt. Bluff
- 21: G "1" FI G 6s .65 nm NE of Alcatraz
- 23: RW "A" Mo (A) east of Angel Island
- 24: R "6" FI R 4s bell, 1.1 nm east of Quarry Pt.
- BYC: Yellow column "BYC" east of COC

- CM2: R "2" FI R 6s on outer end of Corte Madera Channel
- NO: North Approach Buoy FI Y 4s to San Francisco Channel (ocean)
- SO: South Approach Buoy FI Y 4s to San Francisco Channel (ocean)
- NBAY: Temporary YC buoy approx. .6 nm NE of Tiburon YC clubhouse
- NG7: G "7" FI G 2.5s approx. .45 nm SE of Red Rock
- NR12: R "12" FI R 4s approx. 1.3 nm south of Richmond-SR Bridge main channel
- NR14: R "14" FI R 4s approx. .28 nm south of Richmond-SR Bridge main channel
- PB: Point Bonita RG FI (2+1) R 6s bell (ocean)
- RYC: Yellow column "RYC" on southern edge of Southampton Shoals
- SF: Center Channel Buoy RW "SF", strobe FI 2.5s whistle on SF Channel (ocean)
- TYC: Privately-maintained white mark "TYC" off south entrance to Paradise Cay

NORTH BAY MARKS

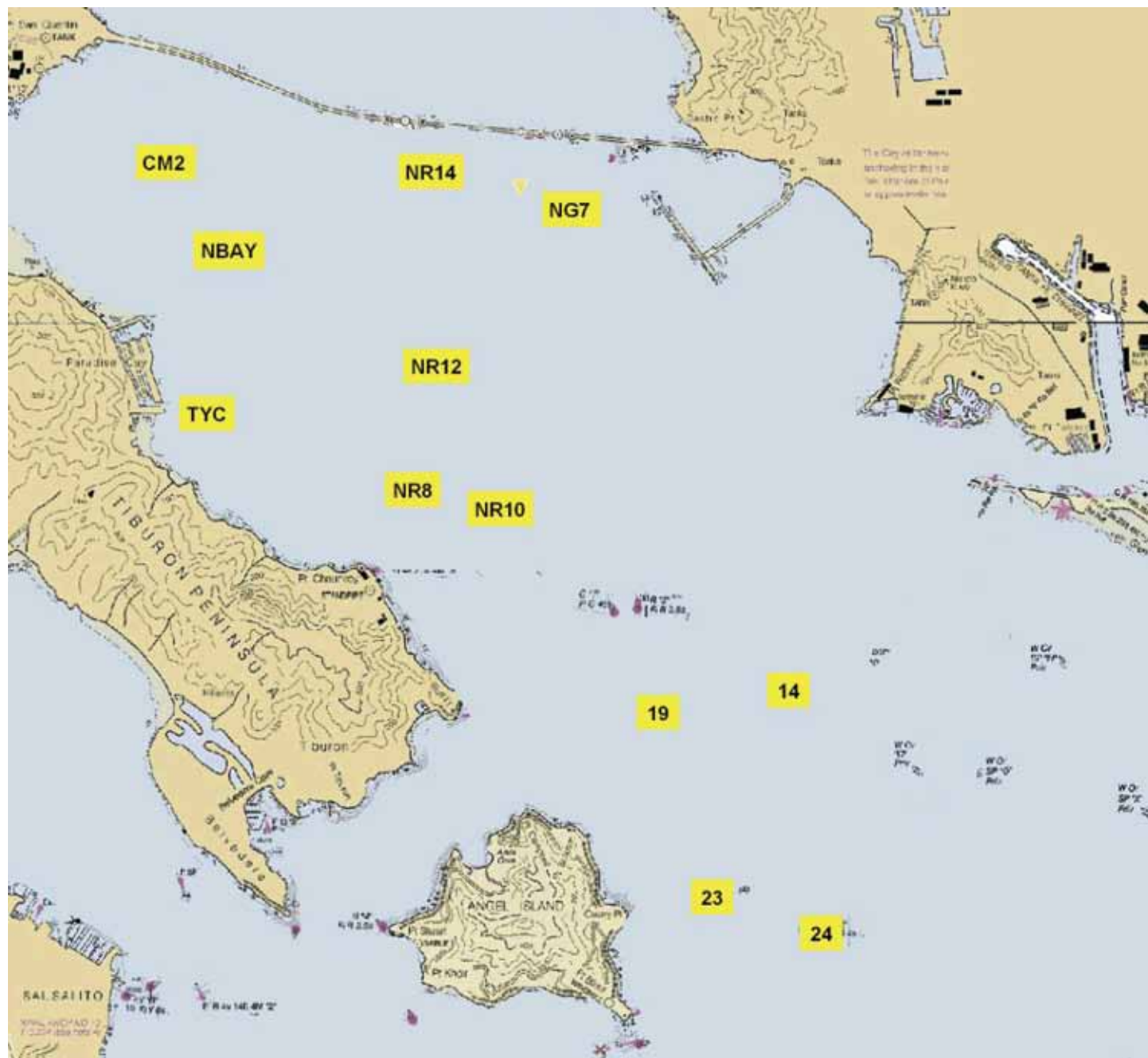

DESCRIPTION OF MARKS

- 14: Southampton Shoals
- 19: R "8" FI R 2.5s approx. 1.5 nm east of Pt. Bluff
- 23: RW "A" Mo (A) east of Angel Island
- 24: R "6" FI R 4s Bell, 1.1 nm east of Quarry Pt.
- CM2: R "2" FI R 6s on outer end of Corte Madera Channel
- NO: North Approach Buoy FI Y 4s to San Francisco Channel (ocean)
- SO: South Approach Buoy FI Y 4s to San Francisco Channel (ocean)
- NBAY: Temp YC buoy approx. .6 nm NE of Tiburon YC clubhouse
- NG7: G "7" FI G 2.5s approx. .45 nm SE of Red Rock
- NR12: R "12" FI R 4s approx. 1.3 nm south of Richmond-San Rafael Bridge main channel
- NR14: R "14" FI R 4s approx. .28 nm south of Richmond-San Rafael Bridge main channel
- SF: Center Channel Buoy RW "SF", strobe FI 2.5s whistle, on San Francisco Channel (ocean)
- TYC: Privately maintained white mark "TYC" off south entrance to Paradise Cay

CAROLE GUNN



DEFINITIONS FOR YRA RACING AREAS

The following racing areas have been defined by the YRA for the purposes of describing the general geographical location and the marks that may be used in a YRA race. Please refer to the individual Sailing Instructions for each YRA race for the exact courses. Temporary marks may be used instead of, or in conjunction with, the described marks in any of these YRA Racing Areas. Sailing Instructions will be available on the YRA website at www.yra.org approximately one week prior to the start of a YRA race.

BERKELEY CIRCLE (OC) RACING AREA

See pages 34-35.

Includes Marks BOC, COC, DOC, EOC, FOC, GOC, XOC, 8, 12, 15, 17.

CITYFRONT RACING AREA

See pages 34-35.

Includes Marks A, X, 6, 16, 17, 18, 21.

KNOX RACING AREA

See pages 34-35.

Includes Marks K, L, N, 4, 12, 15, 21, 23.

NORTH BAY (NB) RACING AREA

See page 36.

Includes Marks CM2, NG7, NR8, NR10, NR12, NR14, TYC, 14.

SOUTH BAY (SB) ALAMEDA SIDE RACING AREA

See page 39.

Races held in this sailing area will use temporary marks in the vicinity of NAS2.

SOUTH BAY (SB) SF SIDE RACING AREA

See page 39.

Includes Marks AS1, NAS2, W1, XS1, 31, 34, 37.

SOUTHAMPTON SHOALS (SH) RACING AREA

See pages 34-35.

Includes Marks N, 7, 12, 14, 19, 21.

TREASURE ISLAND (TI) RACING AREA

See pages 34-35.

Includes Marks EOC, 2, 7, 9, 10, 17, 18, 21.

2016 Wheeler Regatta April 2 & 3 (No Foolin'!)



Saturday: Buoy racing for monohulls and multihulls
Deep water courses

Sunday: Pursuit Race

Berkeley Yacht Club

Details at:

www.Berkeleyyc.org

Contact: Bobbi Tosse

Bobbi@jfcbat.com • (925) 939-9885

FAST, LIGHT, EFFICIENT

Outboard Motor Shop has the power you need to get to or from the race course!



**HONDA
MARINE**



- 2 to 250 horsepower
- As low as 29.5 lbs engine weight!
- 5-year warranty

© 2015 American Honda Motor Co., Inc.
Always wear a personal flotation device while boating and read your owner's manual. 5-year warranty standard on all new Honda outboard engines purchased. Check with participating dealers for complete details.

Outboard Motor Shop
Where the professionals shop!

(510) 533-9290

www.outboardmotorshop.com

333 Kennedy St., Oakland, CA 94606 • Fax 510-533-3374

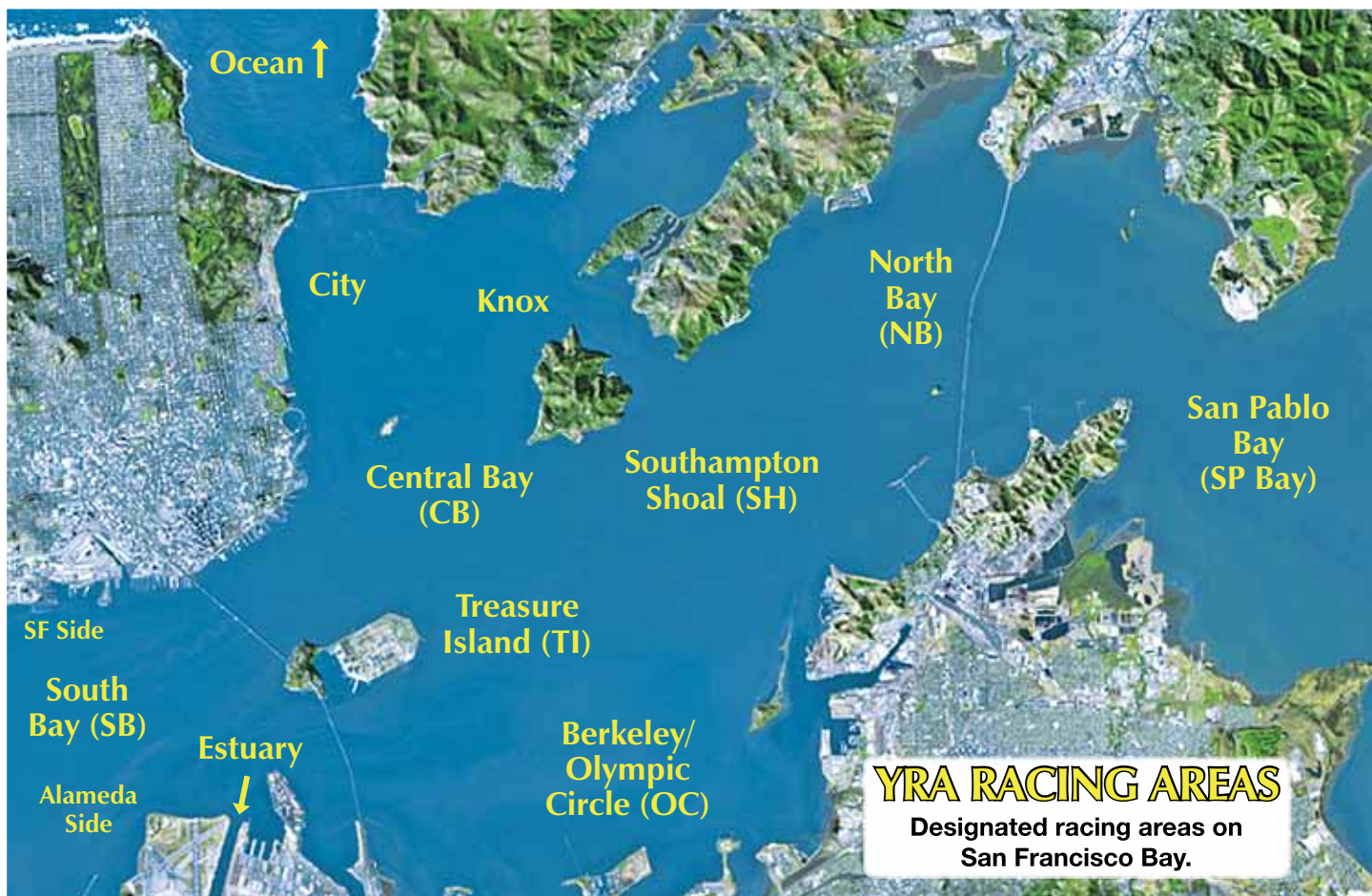

Established 1912

SAUSALITO YACHT CLUB

2016 RACE SCHEDULE

SYC offers excellent racing off the scenic Marin Headlands adjacent to the iconic Golden Gate Bridge. The warm club atmosphere provides a great location for after race bragging or complaining. The bar and galley are open after all the races.



www.sausalitoyachtclub.org/racing

- SYC Chili Midwinter Series: The first Sunday of the month – January 3, February 7, March 6, November 1, December 6.
- Jaws: March 26. A single pursuit race with the start and finish near Sausalito Yacht Club, recalling a club tradition of starts and finishes off the club deck, with the new "Jaws" trophy. A "Predicted Log" race for power boats will be running concurrently with this race for sailboats.
- Great Vallejo Race: April 30 - May 1, start and finish.
- Wooden Boat Invitational: TBA; April, June, August, September.
- Twin Island Series: Three races around Alcatraz and Angel Island on April 23, July 16 and October 15. (You choose your direction around the islands... Course B possibility of Angel Island and Red Rock Island.)
- Sunset Series: Ten spring and summer races on alternate Tuesday nights to set aside work pressures for mid-week competition. The Spring Series starts April 26 and the Summer Series starts July 26 and runs through September. The Sunset Champion of Champions Race is September 24.
- PICYA Lipton Cup Invitational: July 9.
- Women Skippers Race: A race on August 27 with a woman as skipper. "No man may touch the wheel!"
- Rear Commodore's Race: A 20-mile race/cruise to Vallejo Yacht Club on June 25. This is usually a great downwind race with an excellent party and dinner afterward.

SOUTH BAY MARKS



DESCRIPTION OF MARKS

- | | |
|---|--|
| AS1: Yellow sphere approx. .25 nm east of BVBC | 31: Temporary YC buoy approx. 1.2 nm SE of Mission Rock Terminal |
| NAS2: NAS Alameda Channel Mark "R2" FI R 4s | 33: Red buoy "4" FI R 4s, Oakland Inner Harbor Entrance Channel |
| SC1: Red & green buoy "SC" FI G (2+1) approx. 1 nm ENE of Mission Rock Terminal | 34: Red buoy "2" FI R 2s approx. .5 nm east of Potrero Point |
| W1: Temporary YC buoy approx. 1 nm east of Army St. Terminal | 35: Green daymarker "3" FI G 2.5s, Alameda NAS Entrance Channel |
| XS1: Temporary YC buoy approx. halfway between 31 & AS1 | 36: Red daymarker "4" FI R 4s, Alameda NAS Entrance Channel |
| | 37: Green buoy "5" FI G 4s approx. 1 nm SSE of Army St. Terminal |

HELPFUL INFO FOR FILLING OUT AN NCPHRF APPLICATION

Getting a PHRF rating for your boat is one of the easiest ways to get involved in the myriad forms of Bay Area racing. If you have a well-known sailboat, it's likely the YRA already has a rating number on file for your boat type. However, many boats have been modified or may have different sail configurations affecting their speed. For this reason, all boats need their measurements submitted to the YRA in order to get a rating certificate. To make it easier, the YRA has prepared the following instructions to help you fill out the NCPHRF rating application on page 49.

For unmodified class boats, common measurements for items such as I, J, P, and E, as well as ballast and displacement, can be found online, in sales brochures, in class rules, or from your sailmaker. However, if you have a modified or non-class boat, or cannot find all the required information for your boat, the following guidelines can help walk you through the required measurements.

If you have a current or expired certificate and need to make changes to your boat's configuration, please contact the YRA office to discuss your changes and what forms may be necessary. Any other questions please contact the YRA office at (415) 771-9500 or via email at info@yra.org.

SAIL NUMBER

This should be a number that the YRA office has assigned to your boat. Please call the YRA office for more information. Sail Prefix is a country code. This space can be blank or it might say USA or IRL.

CLASS/TYPE

We are looking for the type of boat you have – like a Cal 20 or Islander 36. If your boat is custom-made or one of a kind, please indicate so. If it was designed under some rule, please tell us what rule; e.g., 6-meter, IOR 1/4-ton, etc. In this case, if you have any measurement certificate, no matter how old, please include a copy of it with your application for rating.

ONE DESIGN RATING

Refer to the NCPHRF Rules (www.yra.org) to find out if this applies to you. It is anticipated that other members in your class who know and understand your rules and limitations, as modified by Section V, will monitor the OD ratings.

RIG AND SAIL MEASUREMENTS

What is the source of the information provided? We are looking for where you obtained the information on your certificate. Please indicate by circling which sources apply.

FORETRIANGLE

- I Vertical distance from upper point of 'I' to lower point of 'I'
Upper point of 'I' is the highest of:
 1. Intersection of mast and highest jibstay.
 2. Highest sheave for jib halyard drawn horizontal to mast.Lower point of 'I' is the sheerline abreast the mast (not the cabin top).
The sheerline is the intersection of the deck and the hull.
- J Horizontal distance from mast to where the forward-most jibstay intersects the deck, or jib tack. Note that 'JC' is no longer on this form.

LARGEST HEADSAIL

Largest Headsail percent is $LP/J \times 100$. The LP (Luff Perpendicular) of your jibs is determined by measuring the distance from the clew to the nearest point on the luff. This is done by holding the zero end of a tape measure at the clew (defined as the intersection of the leech and the foot), removing the wrinkles from the area to be measured, and swinging an arc up and down the luff, recording the minimum distance, then dividing by J and multiplying by 100. For example, suppose you measure an LP of 15.5 feet on your biggest headsail, and your J is 10 feet. Your largest headsail is $15.5/10 \times 100 = 155\%$, which happens to be the largest non-penalty headsail allowed under PHRF for a 10-ft J. Your sailmaker is also a source of information on sail dimensions.

SPL = Spinnaker Pole Length

Spinnaker Pole Length is the length of the spinnaker pole when set in position on the mast; measured from the front face of the mast to the extreme outboard end of the pole. Please note the distinction between a whisker pole and a spinnaker pole: A whisker pole may be used to pole out any jib (but may NOT attach to any type of spinnaker), may be of any length, and may be adjustable. Information on your whisker pole is not required by PHRF, and should not be used as an answer for the spinnaker pole length, as it will often draw an unnecessary penalty.

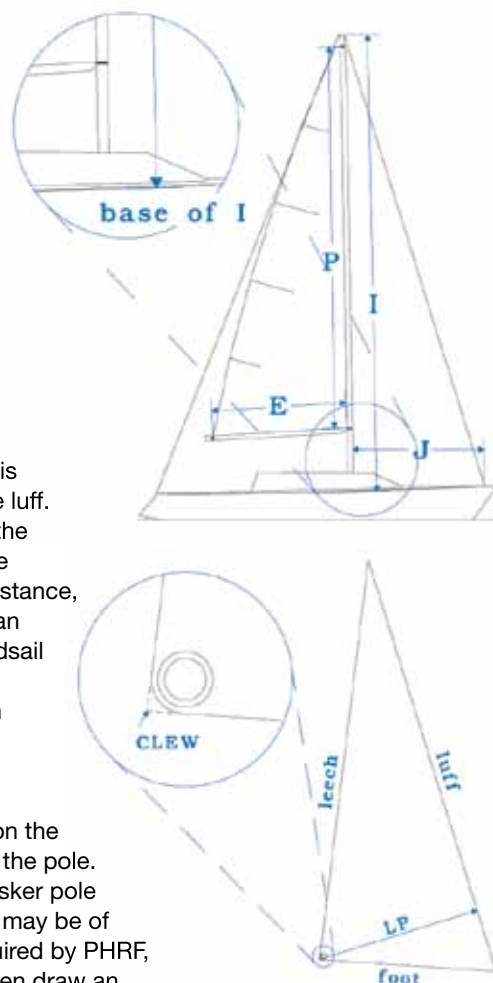

continued on page 42

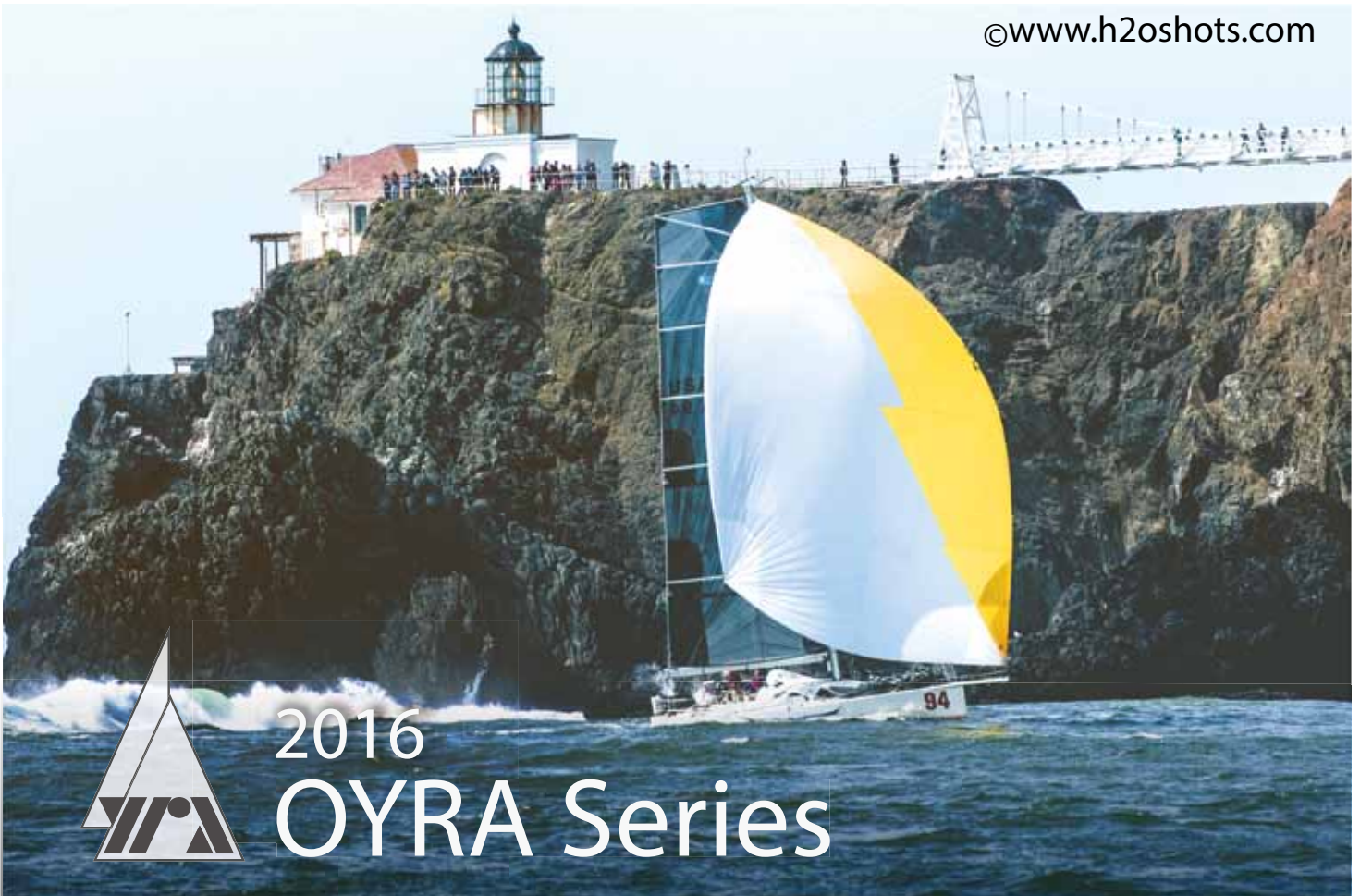

2016 OYRA Series

April 16th

May 21st

June 11th

June 25th

July 16th

August 6th

August 27th & 28th

September 10th

Heed the call of the ocean and head out the Golden Gate with OYRA. 9 races are scheduled for 2016, including the popular Full Crew Farallones race and the season opening Full Crew Lightship Race. We offer Divisions for full crewed boats, single and double handed boats and multihulls. One-Design classes can be added to any race.

The Race Sign Up, Notice of Race, and Sailing Instructions for each regatta are available at www.yra.org.

Daily and Series Championship trophies will be passed out on Nov. 15th, 2016 at the Berkeley Yacht Club.

HELPFUL INFO FOR FILLING OUT AN NCPHRF APPLICATION

continued from page 40

ISP ('I' for the spinnaker)

ISP = spinnaker hoist. Measured from the underside of the spinnaker halyard, when drawn horizontally forward from mast, to the level of the sheerline abreast the mast. The sheerline is the intersection of the deck and the hull.

Note: In some cases, 'I' and 'ISP' are the same. If your spinnaker halyard exits the mast above the upper point of 'I' as described above, then your 'ISP' will be greater than 'I'.

JSP (for boats with sprits and asymmetric spinnakers only)

JSP = spinnaker 'J' horizontal distance from mast to the forward most attachment point for the spinnaker tack.

If this location is adjustable, as with an adjustable bow pole, then measure with the bow pole fully extended on centerline.

TYPE OF RIG

Sloops come in two varieties: 'masthead,' where the forestay goes to the top of the mast; and 'fractional,' where the forestay is anchored to the mast somewhere below the top of the mast. Other types of rigs include ketch, yawl, cutter or catboat.

MAST MATERIAL

What is your mast made of? Common materials are aluminum, wood, carbon, fiberglass, and 'other.'

STANDING RIGGING MATERIAL

What material are your shrouds made of? In part, we are looking for boats that have changed their standing rigging.

continued on page 44



UNI-TITANIUM[®]
ULTIMATE PERFORMANCE

boot VEOLIA

Buy With Confidence
Race With Confidence

UK Northern California
2021 Alaska Packer Pl.
Alameda, CA 94501
Tel: 510-523-3966

UK
SAILMAKERS



2016

Spring/Summer Series

Spring Series

April 9th

May 14th

June 18th

Summer Series

July 23rd

August 13th

September 17th

The YRA Spring and Summer Series features short course racing in the Central and South Bays. The series is open to PHRF and Sport Boats and to One-Design fleets. 2 races are scheduled to be held on each race day.

Racers can sign up for either the Spring or Summer Series, or for both. The Race Sign Up, Notice of Race, and Sailing Instructions for each series are available at www.yra.org.

Series Championship trophies and Daily Awards will be passed out on Nov. 15th, 2016 at the Berkeley Yacht Club.

HELPFUL INFO FOR FILLING OUT AN NCPHRF APPLICATION

continued from page 42

MAINSAIL

P = Mainsail Hoist (distance between bands)

E = Mainsail Foot (distance from aft edge of mast to the inner edge of the band on the boom)

HB = The total width of the top of the sail from the front of the luff rope to the top aft corner.

MGU and MGM

MGU (Main Girth Upper) and MGM (Main Girth Middle) are girths measured on your mainsail.

These girths measure the width of mainsails one-quarter and one-half the distance down the leech from the head. Measure your girths by folding the head (front corner of headboard) to the clew, smoothing the leech and marking the fold at the leech (MGM starting point). Next, fold the head to the mid-leech point and mark this new fold on the leech (MGU starting point). Now lay the sail out flat. Hold the zero end of a tape measure at the MGM starting point on the leech. Swinging an arc up and down the luff, record the minimum distance measured as your MGM. Remove the wrinkles from the area to be measured. Repeat this process for measuring your MGU.



Py and Ey are similar to P and E dimensions for the aft sail on ketches, yawls and schooners.

SYMMETRIC SPINNAKER

Symmetric spinnakers have the following characteristics: (a) luffs are of equal length; (b) the sail is symmetric about its vertical centerline.

SL = Spinnaker Luff (Refer to the NCPHRF Rules at www.yra.org for the non-penalty limit.)

SSMG (Symmetric Spinnaker Mid-Girth)

SSMG is determined by measuring the width of your sail at mid-luff to mid-luff

SSF = Spinnaker Foot Length

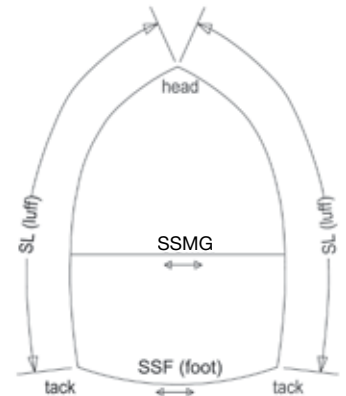

ASYMMETRIC/CRUISING SPINNAKERS

Non-Penalty Area Limits

Cruising/Asymmetric Spinnakers are limited in area not to exceed the area of I and J – or ISP and SPL – based 180% symmetric spinnakers for that boat. To calculate the actual area for the symmetric spinnaker, use the formula for “Area” below, substituting SL (symmetric spinnaker luff) for SLU and SLE.

The formula for determining the actual area of all types of spinnakers is as follows:

$$\text{Area} = (\text{SLU} + \text{SLE}) \times .25 \times \text{ASF} + (\text{ASMG} - .5\text{ASF}) \times (\text{SLU} + \text{SLE}) / 3$$

In the case of Symmetric Spinnakers, replace SLU and SLE with SL, ASMG with SSMG, and ASF with SSF.

SLU = Spinnaker Luff Length

SLE = Spinnaker Leech Length

ASMG = Spinnaker mid-girth measured between the mid-points of the spinnaker luff and spinnaker leech

ASF = Spinnaker foot length

Note on ASMG:

ASMG less than .75 x ASF is not allowed.

How far aft can you articulate your spinnaker tack?

0 degs (fixed)

___ degrees

We want to know if you plan on setting the tack of your cruising or asymmetric spinnaker on a pole that can be squared aft. Sails set from the bow of the boat, or from a non-rotating pole (bow sprit), are of the zero degree category. If the tack of the sail is set on a pole that can be rotated while sailing, we want to know the maximum angle of rotation, measured at the mast between the centerline of the yacht and the pole. If an asymmetric spinnaker is tacked to a spinnaker pole, articulation must be listed as 90 degrees.

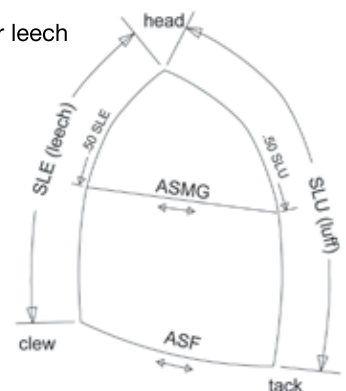

continued on page 46



2016 WBRA Series

April 23rd

August 6th

May 7th

September 24th

June 4th

October 8th

Have a classic Bear Boat, Bird Boat, IOD, Folkboat or Knarr? Then The YRA WBRA series wants you to join the iconic WBRA. Most races are held in the Central Bay and have 2 races scheduled for each race day.

The Race Sign Up, Notice of Race, and Sailing Instructions for each regatta are available at www.yra.org.

Series Championship trophies will be passed out on Nov. 15th, 2016 at the Berkeley Yacht Club.

HELPFUL INFO FOR FILLING OUT AN NCPHRF APPLICATION

continued from page 44

Please fill out the following two fields in the “Foretriangle” box:

ISP = Spinnaker hoist, measured from the underside of the spinnaker halyard, when drawn horizontally forward from mast, to the level of the sheerline abreast the mast.

JSP = Farthest distance from front of mast to asymmetric spinnaker tack location. Note that this can be much greater than J on sprit boats.

Setting and Sheeting Limits: For asymmetric spinnakers:

TACK: Sail may be tacked to the deck or to a pole. PHRF Application must state if the pole can be articulated to move the tack off hull centerline and how many degrees it can move. JSP must be recorded if greater than J.

HEAD: Halyard location may be at any height on the mast. If the dimension ISP is greater than I, then ISP must be recorded on the application.

CLEW: Sail may be sheeted consistent with the RRS. Racing Rules of Sailing can be found on the US Sailing website at: www.ussailing.org/rules.

The performance of Cruising/Asymmetric Spinnakers is not yet completely defined. Boats with excessive JSPs or ISPs and boats with the ability to move the tack of the sail off centerline may incur some rating adjustment. The PHRF Committee will be studying the performance of these various arrangements, and, if considered necessary by this committee, this rule and/or its limits may change.

HULL MEASUREMENTS

Drawings and photos are not required for well-documented production boats. However, if the boat is relatively rare, or not common in the Bay Area, drawings and/or photos are a must. We cannot rate an unknown boat using only the information on the application form. Measurements below are for the boats in ‘measured trim,’ not ‘sailing trim,’ using IMS wording. Your boat is equipped as it would be for racing, but without crew, sea bags, or consumable supplies, and with all tanks empty.

HULL

LENGTH OVERALL

How long is your boat? If it has a bowsprit, please give the length of the hull and the bowsprit separately.

WATERLINE LENGTH

How long is the part of the boat in the water? Ignore the rudder.

MAXIMUM BEAM

What is the width of your hull at its widest point?

MAXIMUM DRAFT

What is the depth of the lowest point of the keel or board below the waterline? If the boat has a lifting board or keel of any type, draft is measured with this device fully lowered. Give the change in draft with the board raised separately.

DISPLACEMENT

TOTAL

This is the weight of your boat ready to race as described above.

BALLAST

We are looking for the weight of your keel. PHRF requires minimum ballast of 400 pounds. If your boat has ‘internal ballast’, it should be included. Internal ballast is typically in the form of lead ingots bolted to the hull, and is NOT in the form of usable equipment or supplies. If your boat has been measured under some rating rule, and you have subsequently removed the internal ballast, this change must be reported in writing to the PHRF Committee.

BALLAST MATERIAL

Typical answers here are lead or iron, and sometimes water.

TRAPEZE/HIKING STRAP

These are allowed in One-Design Classes where the class rules clearly state that the hiking aids are allowed. They may not be used unless your PRHF application so indicates.

continued on page 48



2016

Weekend Regattas

The Great Vallejo Race

April 30th & May 1st

The Westpoint Regatta

July 9th

The 2nd Half Opener

July 30th & 31st

The Season Closer

September 24th & 25th

Spend your weekends racing in YRA's most popular regattas. Divisions available for PHRF Boats, Sport Boats, One Design Fleets, Multihulls, Short-handed Crews and Non-Spinnaker boats.

Go to www.yra.org for more information on the great after race activities available on the Saturday of each Weekend Regatta as well as to find the race sign up, Notice of Race, and Sailing Instructions for each regatta.

New in 2016: Series Trophies will be awarded for the Great Vallejo Race, plus, Downwind ratings will be used for Saturday!

Awards will be passed out on Nov. 15th, 2016 at the Berkeley Yacht Club.

HELPFUL INFO FOR FILLING OUT AN NCPHRF APPLICATION

continued from page 46

MOVABLE BALLAST

Does your boat have ballast that can be moved while sailing? The possibilities include:

- (a) Water ballast which can be moved from side to side – or discharged for runs and restored for beating.
- (b) Keels which can be inclined or canted.
- (c) And others.

Movable ballast presents several difficulties. The biggest is in US Sailing/Racing Rules of Sailing (2013-2016) Rule #51 (Moving Ballast), which states quite clearly that movable ballast is not legal when racing under the US Sailing rules. There are a (very) few races where the race instructions alter the RRS, and specifically allow movable ballast, which is why this is on the PHRF form at all. If you use movable ballast, it is your responsibility to be sure that it is legal in the races in which you are sailing. *Just because it is on your PHRF Certificate does not mean you can race with a movable ballast.*

KEEL TYPE

FIXED

If your keel cannot be moved while you are sailing, then we consider it fixed.

MOVABLE

If your keel can be moved while you are sailing, then we consider it movable, and we need to know about it. This includes keels that move up and down, pivot around a pin (swing keel), or cant from side to side.

KEEL/CENTERBOARD

This is really a sub-class of movable keels, where the boat has a conventional keel, but also has a foil that can extend down below the bottom of the keel.

ENGINE

Do you have an inboard, outboard, or no engine at all?

PROPELLER

We need to know the number of blades on the propeller, and whether they are fixed blades or folding/feathering. If the engine is an outboard, we assume the propeller is not in the water while you are racing, so in the case of outboards, we do not consider what type of propeller you have.

MODIFICATIONS

UNMODIFIED CLASS BOAT

Check this box if your boat is a serially produced yacht that has not been altered.

MODIFIED CLASS BOAT

Check this box if your boat was originally a production yacht, but has undergone changes since its original manufacture. Examples include: a new keel, change in ballast, new rudder, new mast made of different material than the original, different number of spreaders on the mast, change in hull shape, etc. Include anything that would make you *unwelcome* racing against your unmodified sisterships.

NON-CLASS CUSTOM BOAT

Check this box if your boat is essentially a one-of-a-kind custom boat. If your boat is of this type, please refer to the NCPHRF Rules at www.yra.org for information we will need to handicap your boat.

DESCRIBE MODIFICATIONS

Please explain modifications, movable ballast, hiking aids here. Please feel free to write on the back of the form if you need more space.

RATING FEES

New Certificates: YRA Members, \$50; Non-Members, \$75

Renewals: YRA Members, \$35; Non-Members, \$65

Out of Area Certificates (boats hailing from outside of US Sailing Area G): \$75

CHANGES TO EXISTING CERTIFICATES

YRA Members: No charge

Non-Members: \$30

NORTHERN CALIFORNIA PHRF RATING APPLICATION 2016

1070 Marina Village Pkwy, Ste 202-G, Alameda, CA 94501

Phone: (415) 771-9500 E-mail: PHRF@yra.org Fax: 415-276-2378

THIS FORM IS FOR BOATS NOT PREVIOUSLY RATED OR BOATS WHICH DID NOT HAVE A 2015 CERTIFICATE.

The NCPHRF Committee has no responsibility for the seaworthiness or safety of yachts rated, but cites US SAILING Fundamental Rule 4, "It shall be the sole responsibility of each yacht to decide whether or not to start or to continue to race".

Name: _____	Boat Name: _____	Sail Number: _____
Street: _____	Boat Model: _____	
City, State, Zip: _____	Manufacturer: _____	Yr Built: _____
Evening Phone: _____	Daytime Phone: _____	Designer: _____
		Yr. Designed: _____
Email Address: _____	U.S. Sailing #: _____	YRA Member #: _____
Yacht Club Affiliation: _____	Marina: _____	Berth/Slip #: _____

Please refer to the NCPHRF Rules and Guidelines for assistance in successfully completing this application

Do you want an ODR (One Design Rating)?

YES NO N/A

What is the source of the information provided?

Circle all that apply.

Measurement Certificate Sales Brochure Class Rules Sailmaker Designer Own Measurement

Please provide accurate drawings or pictures showing side and end views of your boat from deck to bottom of keel and attach to this application. Where possible, give measurements in feet and decimals.

<p style="text-align: center;">Foretriangle</p> <p>I: <input type="text"/> J: <input type="text"/></p> <p>Largest Headsail: <input type="text"/> % J SPL: <input type="text"/></p> <p>ISP: <input type="text"/> JSP: <input type="text"/></p> <p>Type of Rig: <input type="text"/></p> <p>Mast Material: <input type="text"/></p> <p>Standing Rigging Material: <input type="text"/></p>	<p style="text-align: center;">Main</p> <p>P: <input type="text"/></p> <p>E: <input type="text"/></p> <p>HB: <input type="text"/></p> <p>MGU: <input type="text"/></p> <p>MGM: <input type="text"/></p> <p style="text-align: center;">Mizzen</p> <p>PY: <input type="text"/></p> <p>EY: <input type="text"/></p>	<p style="text-align: center;">Symmetric Spinnaker</p> <p>Yes/No <input type="checkbox"/></p> <p><i>If yes, complete the following:</i></p> <p>SL: <input type="text"/></p> <p>SSMG: <input type="text"/></p> <p>SSF: <input type="text"/></p>	<p style="text-align: center;">Asymmetric/Cruising Spinnaker</p> <p>Yes/No <input type="checkbox"/></p> <p><i>If yes, complete the following:</i></p> <p>SLU: <input type="text"/> How far aft can you articulate your spinnaker tack? If an Asymmetric spinnaker is tacked to a spinnaker pole, articulation must be listed as 90 deg</p> <p>SLE: <input type="text"/></p> <p>ASMG: <input type="text"/></p> <p>ASF: <input type="text"/> <input type="checkbox"/> Fixed @ 0 deg or: <input type="text"/> Degrees</p>
---	---	---	---

<p style="text-align: center;">Hull</p> <p>Length Overall: <input type="text"/></p> <p>Waterline length: <input type="text"/></p> <p>Maximum Beam: <input type="text"/></p> <p>Maximum Draft: <input type="text"/></p>	<p style="text-align: center;">Displacement</p> <p>Total: <input type="text"/> lbs</p> <p>Ballast: <input type="text"/> lbs</p> <p>Ballast Material: <input type="text"/></p> <p># of Trapezes/Hiking Straps: <input type="text"/></p> <p>Is any of your ballast moveable? <input type="checkbox"/></p>	<p style="text-align: center;">Keel</p> <p>Fixed, Moveable or Keel/Centerboard?</p> <p><input type="text"/></p>	<p style="text-align: center;">Engine</p> <p>Inboard, Outboard or None?</p> <p><input type="text"/></p>	<p style="text-align: center;">Propeller</p> <p># of Blades (2 or 3)?</p> <p><input type="text"/></p> <p>Fixed, Folding or Feathering?</p> <p><input type="text"/></p>
---	--	--	--	---

This is a: (check one) Unmodified Class Boat Modified Class Boat Non Class (Custom) Boat

Modifications Describe modifications/Comments/Moveable Ballast/Trapeze or Hiking Straps below:

The NCPHRF rating certificate is a contract between you, the NCPHRF Committee, and your competitors. You and your competitors expect this form to be accurate and that the reported characteristics will be maintained while racing. Failure to advise the NCPHRF Committee in writing of ANY modification to your boat which will alter its sailing performance may be grounds for protest and disqualification of the yacht. Your rating is valid through December 31 of the year issued. I certify that the above information is accurate and correct, that I have read the NORTHERN CALIFORNIA PHRF RULES AND GUIDELINES, and concur with, and agree to sail by those terms and conditions.

Signature of owner _____ Date: _____

Rating Fees: \$100 (includes YRA membership) or \$50 (YRA member with a current membership) or \$75 (Non-YRA Member and out of area vessels)

Make check payable to YRA. To pay by MasterCard or VISA please provide card information below, including billing street address and zip code

Card Number: _____ Exp Date: _____ CVV # _____ Name on Card: _____

Card Holder's Signature: _____ Billing Address: _____

Office use only

PHRF Rating: _____ C.C. Check # _____ Amount PD _____ Date Rec'd in office _____



PINEAPPLE SAILS
 Phone (510) 522-2200
 Fax (510) 522-7700
 www.pineapplesails.com
 2526 Blanding Ave., Alameda, CA 94501

Stocking Dealers For

MUSTO

Foul Weather Gear



dubarry
of Ireland

Sailing Footwear

spinlock

PFDs and Tethers



When only the best will do

FLAGS

A		J		S			
B		K		T			
C		L		U			
D		M		V			
E		N		W			
F		O		X			
G		P		Y		'Y' FLAG: Life Jackets must be worn.	
H		Q		Z			
I		R		0			
1		2		3			
4		5		6			
7		8		9			

★ For Bay Area Weather Call (831) 656-1725 ★

JANUARY 2016

● indicates full moon.

→ indicates 2-day races. **YRA events indicated in bold type.**

S	M	T	W	Th	F	S
3	4	5	6	7	8	9
10	11	12	13	14	15	16
17	18	19	20	21	22	23
24	25	26	27	28	29	30
31						

WEEKDAY & SPECIAL EVENTS

- January 1:**
- Welcome to 2016
 - Brrrr Rabbit, CPYC – SB
- January 15-18:**
- Progressive Insurance San Francisco Boat Show, NMMA – McCovey Cove/Pier 48
- January 17-22:**
- Quantum Key West Race Week, Premiere Racing – Key West, FL
- January 18:**
- Martin Luther King Jr. Day



JOHN LIEBENBERG

SATURDAY

Opti Midwinters #2, RYC – Keller Cove
 Tiny Robbins Midwinter #3, VYC – NB
 Frostbite Series #3, BenYC – Carquinez
 Seaweed Soup Midwinter #3, GGYC – City

2

California Dreamin', SDYC – San Diego →
 Midwinters #5, BYC – OC
 Little Daddy, RYC – SH
 Winter #3, SeqYC – SB
 Midwinter #1, TYC – NB
 Winter One Design, RegattaPRO – OC
 Midwinter #3, BVBC – SB/SF
 Santana 22 Team Racing, SCYC

9

Midwinters #1, CYC – Knox →
 Midwinters #3, SCYC

16

Jack Frost #2, EYC – YRA 10
 Redwood Cup #3, SeqYC – SB
 Island Fever #3, SBYC – SB/SF

23

Three Bridge Fiasco, SSS – CB

30

SUNDAY

Chowder #12, BYC – OC
 Midwinter #3, SYC – Knox
 Small Boat Midwinters #2, RYC – SH
 Sunday Brunch #1, OYC – Estuary

3

California Dreamin', SDYC – San Diego
 Midwinters #6, BYC – OC
 Island Days Midwinter #3, IYC – Estuary
 Winter Beercan #1, CPYC – SB

10

Midwinters #2, CYC – Knox
 Chowder #13, BYC – OC
 Sunday Brunch #2, OYC – Estuary

17

Chowder #14, BYC – OC
 Winter Beercan #2, CPYC – SB

24

Chowder #15, BYC – OC
 Sunday Brunch #3, OYC – Estuary

31

CHRIS BOOME INSURANCE AGENCY

800-853-6504
San Francisco Bay



MARINE INSURANCE SPECIALIST WITH
ACCESS TO ALL MAJOR CARRIERS

IF YOU OWN A BOAT OR CAR YOU NEED A
PERSONAL UMBRELLA POLICY

IF YOU ARE GOING TO MEXICO IN YOUR BOAT OR
CAR YOU NEED MEXICAN LIABILITY INSURANCE

Here's what our customers have to say:

"I have been dealing with Chris Boome for over six years and 25,000 miles of coastal and ocean sailing. The service that Chris delivers allows me to sail with confidence knowing that I am fully covered wherever my sailing adventures take me. Chris being a sailor himself fully understands my requirements and has proven that he can provide a very competitively priced insurance policy."

– Rob Andrews, Swan 53 *Mistress*, Pacific Northwest

"Chris Boome goes above and beyond. When I suddenly came up on the South Beach Harbor waiting list 10 years ago, but with no boat, Chris recommended I consider an Islander 36. Chris has been insuring our Islander ever since. Over the years he has dispensed advice on racing, cruising, repairs and sailmakers. Recently we incurred some serious damage and Chris was right by my side working with boat yards, surveyors and the insurance company claims department to make sure Kapaï could enjoy another 10 years plus on the Bay."

– Rick Egan, I36 *Kapaï*, San Francisco Bay

"Chris Boome has consistently delivered the insurance we need for the past seven years. Despite the complex needs of a voyaging yacht with changing plans, Chris always delivered a solution. Working with Chris has always been a pleasure and his office has always been very efficient and provided added value."

– Herb Hunt, Custom Farr 50 P.H. *Wandering Farr*, Caribbean

"We have been using Chris Boome for insurance on *Golden Moon* for 14 years. Chris is knowledgeable and fair, and responds promptly to our needs. He is an expert sailor and brings great knowledge to all discussions on sailing. I recommend him whole heartedly."

– Kame Richards, Express 37 *Golden Moon*, San Francisco Bay

Call Chris 650-373-0595 • 650-464-0728 cell

Boomeins@aol.com

www.chrisboome.com

License: OA99058

THE VIEW IS A LOT BETTER
WHEN THERE IS NO ONE
IN FRONT OF YOU!

ERIK SIMONSON / WWW.PRESSURE-DROP.US



Buzz Blackett's *California Condor**

*Powered by Pineapples.



PINEAPPLE SAILS

2526 Blanding Ave
Alameda, CA 94501
www.pineapplesails.com
(510) 522-2200

YOUTH SAILING

Looking for a new way to entertain your kids this year? Look no further than the Bay Area's dozens of junior sailing programs. Many offer scholarships, and, with rare exception, you don't need to have your own boat. Unless noted below, club membership is not necessary. High School sailing for students in grades 9-12 takes place around Northern California in the Pacific Coast Interscholastic Sailing Association. If your high school doesn't have a team – or enough students to field a team – don't fret. Most programs allow students from several schools to form a single team.

ALAMEDA COMMUNITY SAILING CENTER

info@sailalameda.org; www.sailalameda.org

Summer Camps, ages 8-18. When: June, July and August.

8-13 age level camp – Discover Sailing (Entry Level training)

8-13 age level camp – Seasoned Sailors (for returning graduates of Discover Sailing)

13-18 age level camp – Teen Camp (for teens of all skill levels)

Discover Sailing runs all summer – check website for where Seasoned Sailors and Teen Camp dates will be added.

Sessions: 2 weeks, Monday-Friday, 9 am-4 pm (Extended care 8:30 am-5 pm available.)

Session 1: June 10-July 1; Session 2: July 4-15; Session 3: July 18-29;

Session 4: August 1-12; Session 5: August 15-26. Boats: JY Trainers, CFJs.

2016 pricing \$625/may change without notice. Needs-based scholarships available.

Weekend classes, Open Sails and other sailing events will be scheduled throughout the year. Visit www.sailalameda.org for further details and pricing.

BENICIA YC

Derith Lutz, for more info: (707) 746-0739

youthsailing@beniciayachtclub.com; www.beniciayachtclub.com (Programs)

Dates TBA in late March on our website. YC member discounts, sibling and multiple camp discounts, and scholarships available on all programs.

Half Day Camps, ages 8-12 with no sailing experience. Cost: \$275

Full Day, One week Camps, ages 10-18 or young sailors with experience. Cost: \$375

Intermediate Sailing, more experienced sailors.

Boats: Vanguard 420, CFJ (provided). Cost: \$375

High School Sailing Special Programs

Boats: DeWitt Dinghies, V420, CFJ (provided). Cost: Sponsored by BenYC for Benicia High School students.

Open Sailing for pre-qualified individuals with certification.

BLUE WATER FOUNDATION (San Francisco)

(415) 392-2018; www.bluewaterfoundation.org

Thursday Sails: Afternoon sail programs with San Francisco Unified School District and the SF Police Department.

Tuesday Sailing Club: Two groups of eight students each, sails almost every week for the school year.

Gleaming Ocean Program: Four-month intensive sailing and teamwork course teaching cruising skills to selected high school students on a 43-ft Hans Christian cutter. Emphasis on building teamwork and self-confidence; mentor system is utilized.

Oceans Gate Program: Working with Alameda County Probation Department, convicted youth are given the opportunity to make their way back to society. Offering both day sails and a multi-month intensive sail training program that will 'graduate' successful students by ocean sailing.

Community Sail Programs: At least one weekend day a month we take various community groups sailing, ranging from Boys and Girls Clubs to Project Avery, an organization for children of incarcerated parents.

Probation Dept. Sails: This newest program works with various youth probation departments throughout the Bay Area and Nevada City/El Dorado County foothills, taking their incarcerated students and students on probation on repeat sails. Usually on weekends.

COYOTE POINT YC (San Mateo)

Gwen Daly, (650) 678-1342, www.cpyc.com

Youth Sailing Summer Camp, ages 8-12. When: One-week sessions, June and July,

Monday-Friday, 9 am-4 pm. Boats: Nine Optimists, Two Lasers. Cost: \$375/week.

10% discount for second child.

ENCINAL YC (Alameda)

Tyler Colvin, (510) 769-0221, juniors@encinal.org, www.encinal.org

Summer Learn to Sail Program, ages 6-18, all levels.

When: 3-week sessions: June 20-July 8, July 11-28, Aug. 1-Aug. 18. Monday-Thursday, 8:30 am-12 or 1-4:30 pm. No class July 4 (class Tuesday-Friday July 4 week).

Boats: Optimists, FJs, J/24s (provided).

Cost: Per 3-week sessions: \$395/EYC members, \$530/non-members.

Family BBQ every Thursday night.

continued on page 54

FEBRUARY 2016

● indicates full moon.

→ indicates 2-day races. **YRA events indicated in bold type.**

S	M	T	W	Th	F	S
	1	2	3	4	5	6
7	8	9	10	11	12	13
14	15	16	17	18	19	20
21	22	23	24	25	26	27
28	29					

WEEKDAY & SPECIAL EVENTS

- February 14:**
- *Valentine's Day: Take your sweetheart for a sail.*
- February 15:**
- *President's Day: Take your president for a sail!*

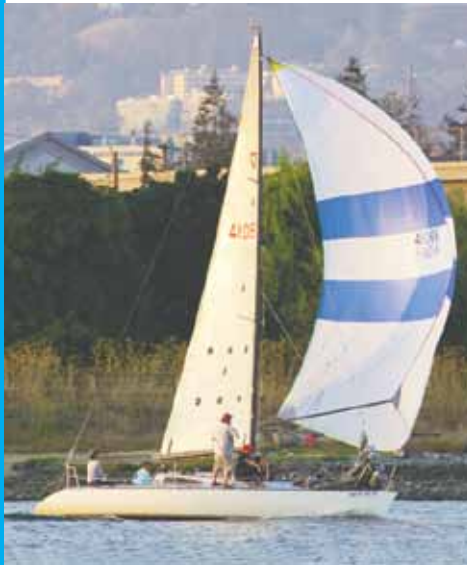

SATURDAY

Opti Midwinters #3, RYC – SH
 Winter #4, SeqYC – SB
 Tiny Robbins Midwinter #4, VYC – NB
 Midwinter #2, TYC – NB
 Seaweed Soup Midwinter #4, GGYC – City
 Double Up and Back, CPYC – SB
 Frostbite Series #4, BenYC – Carquinez
 Spring Series #1, FLYC – Folsom Lake

6

BAYS Optis Regatta #1, EYC – Estuary →
 Midwinters #7, BYC – OC
 Winter One Design, RegattaPRO – OC
 Midwinter #4, BVBC – SB/SF
 Santana 22 Team Racing, SCYC

13

TI Regatta (back up), EYC – Estuary →
 Midwinters #3/Rob Moore Memorial
 Regatta, CYC – Knox →
 Redwood Cup #4, SeqYC – SB
 Long Distance Race #1 SSC – Stockton
 Midwinters #4, SCYC

20

California Dreamin', LBYC – Long Beach →
 Frostbite Series #1, ElkYC – Moss Landing
 Jack Frost #3, EYC – YRA 10
 Single/Doublehanded #1, SeqYC – SB
 Island Fever #4, SBYC – SB/SF
 Spring Series #2, FLYC – Folsom Lake

27

SUNDAY

Chowder #16, BYC – OC
 Midwinters #3, RYC – SH
 Small Boat Midwinter #4, SYC – Knox
 Sunday Brunch #4, OYC – Estuary

7

BAYS Optis Regatta #2, EYC – Estuary
 Midwinters #8, BYC – OC
 Island Days Midwinter #4, IYC – Estuary
 Winter Beercan #3, CPYC – SB

14

TI Regatta (back up), EYC – Estuary
 Midwinters #4, CYC – Knox
 Chowder #17, BYC – OC
 Sunday Brunch #5, OYC – Estuary

21

California Dreamin', LBYC – Long Beach
 Chowder #18, BYC – OC
 Midwinter Champ of Champs, BYC – OC
 Sadie Hawkins, IYC – Estuary
 Winter Beercan #4, CPYC – SB

28

FRED FAGO



Our full service mobile rigging shop travels to your boat, regardless of location. Our first priority is getting you back on the water, **quickly and safely.**

510-681-5815

roguerigger@gmail.com

WWW.ROGUERIGGING.COM



BAMA

Bay Area Multihull Association

37th Annual

Double Handed Farallones Race



March 26

JAN ROLETTO

Bay Area Multihull Association

- Competitive Racing
- BAMA Cup Series
- Web Based Crew List
- Monthly Cruise-outs
- Multihull Seminars
- Social Activities

DHF2016@sfbama.org
 Info@sfbama.org
 650-394-6343

www.sfbama.org

MODERN SAILING SCHOOL AND CLUB



START RACING TODAY!

Join the Team

Get out on the water more.
Improve your skills and learn how to race.

Our **Learn to Race Clinic** is designed with the first year or novice racer in mind. Topics include:

- tides and currents
- sail trim
- basic tactics
- starts
- rounding marks
- basic spinnaker training

Once finished with the clinic, practice your skills by racing in local SF Bay races. With a Coach on board to facilitate training, you will be able to learn by actually racing!

\$795

Next Clinic Starts in Spring

Call the office for dates and to reserve your spot.



(415) 331 - 8250

www.ModernSailing.com

Outstanding Sailing School

YOUTH SAILING

continued from page 52

ENCINAL YC (cont'd)

Full summer 9 weeks: \$1,095/EYC Members, \$1,435/non-members.
Full Day options available for each session.

Advanced Race Team, ages 9-18 by application only.

When: Spring/Summer/Fall. Boats: Optimists, Lasers, 420s (provided).

High School Program, grades 8-12.

When: Weekends and after school September-April. Boats: FJs (provided).

Scholarships available through the Encinal Sailing Foundation.

GOLDEN GATE YC (San Francisco)

Chris Childers, youthsailing@ggyc.com, www.ggyc.org

High School Sailing, grades 9-12

When: Tuesdays and Thursdays, 4-6:30 pm, during the school year.

Interscholastic regattas available to students who attend practice regularly and go to the same school (4 sailors per team). Boats: FJs, 420s (provided).

Cost: \$400 per semester (fall or spring); Annual league fee for teams: \$120 + regatta expenses.

Scholarships available through the GGYC Youth Sailing Foundation.

INVERNESS YC

Tor Taylor, (415) 497-9754 www.invernessyachtclub.org

Summer Program, ages 10-18 (10 by June 21), able to pass swim test; PFD, wetsuit, and helmet required (bring your own).

When: Session I, June 27-July 15; Session II, July 18-August 5; Monday-Friday,

9:30 am-4 pm. Boats: Optimists, Lasers, O'pen Bics, FJs (provided).

Cost: \$900. Need-based financial aid available.

LAKE YOSEMITE SAILING ASSOCIATION (Merced)

Brigitte Bowers-Loeffler, (209) 357-7049, www.lakeyosemitesailing.org

Sail Camp, ages 8-16, able to swim.

When: Multiple Sessions TBA. Boats: Lido 14s (provided).

Mini Camp, ages 8-10, 9 am-1 pm. Cost: \$125.

Basic Camp, ages 10-16, 9 am-4 pm. Cost: \$180.

Advanced Camp, any age, must have completed Basic course. 9 am-4 pm, Cost: \$180.

Scholarship program, member discounts; multiple siblings and/or multiple weeks receive 15% discount.

MONTEREY PENINSULA YC

(831) 372-9686, www.mpyc.org

Summer Sailing Lessons, ages 8-16.

When: One-week sessions starting in early June through early August, except the week of July 4, 9 am-4 pm.

High School Sailing Program When: August-May.

NEHEMIAH (Richmond)

Rod & Joni Phillips, (510) 234-5054, www.sailingacross.com

Crosscurrent Voyages use experiential education, adventure and managed risk-taking for growth and development. Primary goal is assisting youth and youth-at-risk to develop a strong sense of character and community, while instilling self-esteem in a hands-on situation.

OAKLAND PARKS & RECREATION

Sarah Herbelin, (510) 238-2196, www.sailoakland.com

Sailing into Science, fifth graders (teachers may sign up their classes)

Where: Lake Merritt Boating Center. When: School year.

Boats: Pedalboats, dragonboats, kayaks, canoes, whaleboats (provided).

Cost: \$300 per class per day (up to 32 students).

After-School Learn-to-Sail Program, ages 10-17.

Where: Lake Merritt Boating Center When: Weekday afternoons during the school year.

Boats: Optis (provided). Cost: \$165/10 weeks.

Basic & Intermediate Summer Programs, ages 10-17.

Where: Lake Merritt Boating Center. When: One-week sessions, June-August.

Boats: Optis, Sunfish, Catalina 14.2, Hobie Wave (provided).

Cost: \$165/Oakland residents; \$198/non-residents.

Advanced Summer Program, ages 11-17.

Where: Jack London Aquatic Center (Oakland Estuary).

When: One-week sessions, June-August.

Boats: Hobie 16s, Bytes (provided). Cost: \$195 and up.

Youth Sailing Team, grades 8-12 from any school.

Where: Jack London Aquatic Center (Oakland Estuary).

When: Practices and regattas on weekends spring and summer.

Boats: Laser 4.7s or club FJs (provided).

Cost: \$395-\$450/season. Scholarships available for Oakland residents.

PEGASUS PROJECT (Berkeley)

(510) 621-8130, www.pegasusvoyages.org/project.html

Mission is to enable youth to become productive members of a

continued on page 56

MARCH 2016

→ indicates 2-day races.
YRA events indicated in bold type.

● indicates full moon.

S	M	T	W	Th	F	S
		1	2	3	4	5
6	7	8	9	10	11	12
13	14	15	16	17	18	19
20	21	22	23	24	25	26
27	28	29	30	31		

WEEKDAY & SPECIAL EVENTS

- March 9:**
- **Latitude 38 Spring Crew List Party at Golden Gate YC. Check Latitude 38 for more information or see www.latitude38.com.**
- March 17:**
- **St. Patrick's Day: Take an Irish friend sailing!**
- March 20:**
- **Vernal Equinox**



SATURDAY

Spring Keel/Spring One Design, StFYC – City →
Mercury Series #1, EYC – Estuary
Tiny Robbins Midwinter #5, VYC – NB
Midwinter #3, TYC – NB
Seaweed Soup Midwinter #5, GGYC – City
John Pitcher Memorial, CPYC – SB
Frostbite Series #5, BenYC – Carquinez
Spring Series #3, FLYC – Folsom Lake

5

Big Daddy, RYC – OC →
California Dreamin', StFYC – City →
Frostbite Series #2, ElkYC – Moss Landing
Redwood Cup #5, SeqYC – SB
Doublehanded Long Distance, SSC – Stockton
Rites of Spring, OYC – CB/OC
Midwinter #5, BVBC – SB/SF
Santana 22 Team Racing, SCYC

12

Spring Dinghy, StFYC – City →
SF Cup, StFYC – City →
San Francisco Cup, SFYC – OC →
High School Winter Regatta, HMBYC – HMB →
Jack Frost #4, EYC – YRA 10
Small Boat Races #1, EYC – Estuary
Winter #5/St. Patrick's Day Race, SeqYC – SB
Island Fever #5, SBYC – SB/SF
Corinthian Race, SSS – CB
Spring Shorteez Regatta; PHRF 180>, CPYC – SB
Midwinter #5, SCYC
Spring Series #4, FLYC – Folsom Lake

19

Doublehanded Farallones, BAMA – Ocean
Frostbite Series #3, ElkYC – Moss Landing
Singlehanded Race, SSC – Stockton
Jaws Pursuit Race, SYC – Knox/Blossom
Bullship, El Toros, ABRA – Sausalito to SF

26

SUNDAY

Spring Keel/Spring One Design, StFYC – City
Chowder #19, BYC – OC
Small Boat Midwinter #4, RYC – SH
Spring Series #1, SSC – Stockton
Midwinter #5, SYC – Knox
Sunday Brunch #6, OYC – Estuary

6

Big Daddy, RYC – OC
California Dreamin', StFYC – City
Chowder #20, BYC – OC
Island Days Midwinter #5, IYC – Estuary
Winter Beercan #5, CPYC – SB

13

DAYLIGHT SAVING TIME BEGINS

Spring Dinghy, StFYC – City
SF Cup, StFYC – City
San Francisco Cup, SFYC – OC
High School Winter Regatta, HMBYC – HMB
Chowder #21, BYC – OC
Spring Series #2, SSC – Stockton
Sunday Brunch #7, OYC – Estuary
Baxter/Judson #1, PresYC – West CB

20

Chowder Series #22, BYC – OC
Winter Beercan #6, CPYC – SB

27

EASTER

2016 California Offshore Race Week

Spinnaker Cup
May 27th

Coastal Cup
May 29th

In-Port Race
June 1st

SoCal 300
June 3rd

24th ANNUAL Coastal Cup 2016
Monterey to Santa Barbara

**Encinal Yacht Club,
San Francisco Yacht Club,
Monterey Peninsula Yacht Club,
Santa Barbara Yacht Club, and
San Diego Yacht Club**

*invite you to participate in the first
running of this new ocean series.
Enter any leg, or enter the entire series!*

Details on this series can be found at www.offshoreraceweek.com

For Coastal Cup details visit:
www.encinal.org/pageResource/coastalcup/2016/coastalCup.php
or email vicecommodore@encinal.org

For the Spinnaker Cup visit:
www.sfyf.org or www.mpyc.org
or email spinnakercup@mpyc.org

For the SoCal300 visit:
www.socal300.com



HOGIN SAILMAKERS



Photo: Karl Robrock

- CUSTOM SAILS
- EXPERT REPAIRS
- PROFESSIONAL RECUTS
- SUN COVERS
- CUSTOM CANVAS

*Call us today to discuss
your sail inventory.*

510.523.4388

1801-D Clement Avenue, Alameda, CA 94501
sales@hoginsails.com

www.hoginsails.com

YOUTH SAILING

continued from page 54

PEGASUS PROJECT (cont'd)

sustainable society through positive outdoor environmental education and by reinforcing life skills. Objectives: Lifeskills Sails aboard Pegasus for youth including youth at risk; to provide youth participants (and adult crew) with a basic environmental understanding and appreciation of the San Francisco Bay; to provide a multi-year track for under-privileged youth that will enable them to experience their backyard Bay through on-the-water activities.

RICHMOND YC

(510) 237-2821, www.richmondyc.org
Parent or child must be RYC member (jr. membership: \$60/year or \$40/Summer).
Dan Brandt, (510) 237-4100, youthsailing@richmondyc.org

Summer Junior Clinics, ages 8-18.

When: 1-week sessions 6/8-8/14. Details below:

29er Summer Camp, ages 14-18, 9:30 am-3:30 pm. Cost: \$275/week.

Bring your own 29er. Some charters available at \$150/week or \$500 for all 6 weeks.

420/Laser Summer Camp, ages 14-18, 9:30 am-3:30 pm. Cost: \$275/week.

Bring your own boat. Some club boats available to share.

El Toro/Opti Summer Camp, ages 8-18, 9 am-3 pm. Cost: \$275/week.

Some club Optis available for use during program hours only at \$100/week.

Winter Sailing, youth and juniors; 8-18.

Ornaith Keane, Kurt Lahr. Registration starts August 1.

420s: October-March. Club boats available.

High School: October-May. Club boats available.

29ers: October-May. Club boats available.

Lasers: October-March. Some club boats available.

Optimists: October-March. Some club boats available.

El Toros: October-March (BYO).

SACRAMENTO STATE AQUATIC CENTER

(916) 278-2842 or www.sacstateaquaticcenter.com

Summer Youth Aquatic (Basic) Camp, ages 7-18.

Weekly program of sailing and other boating activities.

Qualifies students to rent specific sailboats outside of camp.

Boats: Picos, Lasers, Holder 14s.

SAILING EDUCATION ADVENTURES (San Rafael)

(415) 775-8779, www.sfsailing.org/camps

Mini Camp, ages 8-10. Where: Loch Lomond Marina.

When: One-week sessions, Monday-Friday, 9 am-1 pm. Boats: Catalina 16.5 keelboats, Capri 14.2s. Cost: \$295. Scholarships available.

Summer Camp Basic/Intermediate, ages 10-16. Where: Marin YC.

When: Two-week sessions, Monday-Friday, 9 am-4 pm. Boats: Laser Picos, Lasers. Cost: \$695. Scholarships available.

Advanced/Intro Race Camp, ages 12-18. Where: Loch Lomond Marina.

When: One-week sessions, Monday-Friday, noon-4 pm. Boats: Catalina Capris. Cost: \$325. Scholarships available.

SEA Explorers, ages 8-16.

www.sfsailing.org/explorers

Where: Marin YC. When: One-week session, Monday-Friday, 9 am-4 pm.

Boats: Laser Picos. Cost: \$360. Scholarships available.

ST. FRANCIS YC (San Francisco)

Brent Harrill, (415) 820-3729, www.stfyc.com

Learn to Sail Program, ages 7-16.

When: Saturday mornings, September-November and April-May.

Boats: Optimists, O'pen Bics, 420s (provided).

Cityfront Summer Sailing Camps, ages 7-16.

When: 1-week sessions, 7/5-7/8, 7/25-7/29, 8/1-8/5, Monday-Friday, 9 am-4 pm.

Boats: Optis, O'Pen Bics, Bytes, C420s, windsurfers (provided).

Tinsley Island Summer Overnight Sailing Camps, ages 8-15

When: 1-week sessions, 6/20-8/5 (except Cityfront weeks), Monday-Friday.

Boats: Optis, O'Pen Bics, Bytes, Lasers, windsurfers, kayaks, paddle boards (provided).

Learn to Windsurf Program, ages 8-16

When: Saturdays, September-November and April-May.

Boards: Bic Techno 293 windsurfers (provided).

Introduction to Racing Program, ages 9-16

When: Sundays, September-November and February-March, April-May.

Boats: Optimists and 420s (provided). Cost: See online for fee for all above.

SF MARITIME NATIONAL MARITIME PARK (San Francisco)

Glenn Howe, (415) 215-6219, www.maritime.org

Maritime Park Association operates education programs to increase understanding of our nation's rich maritime heritage.

continued on page 58

APRIL 2016

→ indicates 2-day races.
YRA events indicated in bold type.

● indicates full moon.

S	M	T	W	Th	F	S
					1	2
3	4	5	6	7	8	9
10	11	12	13	14	15	16
17	18	19	20	21	22	23
24	25	26	27	28	29	30

WEEKDAY & SPECIAL EVENTS

- April 1:** • Take a fool sailing!
- April 7-10:** • Strictly Sail Pacific, Sail America – Craneway Pavilion & Marina Bay Yacht Harbor, Richmond
- April 14-22:** • Opti Team Trials, SFYC – Richardson Bay
- April 16:** • South Bay Open Day, SeqYC – SB
- April 16-17:** • Rainier Cup, CGRA
- April 19-29:** • Contender Nationals & Worlds, SCYC
- April 22:** • Celebrate Earth Day on the liquid part.
- April 22-24:** • Newport to Ensenada Race, NOSA

SATURDAY	SUNDAY
Wheeler Regatta, BYC – OC/SB → Interconference Collegiate, StFYC – City → Resin Regatta, SFYC – OC → Trans-Folsom Challenge, FLYC – Folsom Lake Andy Byrd Memorial, CPYC – SB North Bay Series #1 VYC – NB Horsfall-Vincent Regatta CC #1, CYC – Knox Champion of Champions Regatta, SCYC Doublehanded Lightship, IYC – Ocean	Wheeler Regatta, BYC – OC/SB Interconference Collegiate, StFYC – City Resin Regatta, SFYC – OC Spring Series #3, SSC – Stockton
2	3
Opti Harken, SFYC – OC → Big Dinghy, RYC – SH → YRA Spring Series #1 – Knox/Bonita Mercury Series #2, EYC – Estuary Don Wan Regatta, TYC – NB Frostbite Series #4, ElkYC – Moss Landing South Bay Interclub #1, TIYC – SB Summer #1, SeqYC – SB Commodore's Regatta, SCYC	Opti Harken, SFYC – OC Big Dinghy, RYC – SH Estuary Cup, EYC – YRA 10/Alcaz/Estuary
9	10
J/Fest, StFYC – City → 50th Annual Camelia Cup, FLYC – Folsom Lake → One Design Championship, CYC – Raccoon → YRA OYRA Lightship, StFYC – Ocean Commodore's Cup, BVBC – SB/SF Small Boat Races #2, EYC – Estuary Wooden Boat Invitational, SYC – West Alcatraz Intraclub Race 1, RYC – CB Spring One Design #1, SCYC	J/Fest, StFYC – City 50th Annual Camelia Cup, FLYC – Folsom Lake One Design Championship, CYC – Raccoon Spring Series #4, SSC – Stockton Baxter/Judson #2, PresYC – West CB
16	17
PCISA Silver PCCs, EYC – Estuary → YRA WBRA #1, RYC – OC Cal Cup #1, BYC – OC Round the Rocks, SSS – CB Intraclub, StFYC – City Anniversary Cup/Staff Commodore's Cup, SFYC – Knox Twin Island Race #1, SYC – Knox/Alcatraz Frostbite Series #5, ElkYC – Moss Landing	PCISA Silver PCCs, EYC – Estuary Spring Series #5, SSC – Stockton SCORE #1, SCYC
23	24
Elvstrom Zellerbach, StFYC – City → YRA Great Vallejo Race, VYC – NB → Moore 24 Regatta, SCYC →	OPENING DAY ON THE BAY
30	



GREAT VALLEJO RACE

All are Invited

APRIL 30 - MAY 1, 2016

Racers and Cruisers

SAIL THE YRA SCORED SEASON OPENERS & COME TO THE PARTY!

Entertainers, Exhibits, and Sponsor Booths in the Afternoon
 Various Food Vendors will be open 3pm to 8pm Saturday
 Live Band and Dance in the Main Hall – Saturday Evening
 More information will be at www.VYC.org



YOUTH SAILING

continued from page 56

SF MARITIME NATIONAL MARITIME PARK (cont'd)

Programs include daytime and environmental living programs at the Hyde Street Pier. **The Age of Sail/Teacher Workshops:** The Gold Rush, Life on the Barbary Coast. **Overnight Encampment on a Tall Ship Educational Tours/Day Programs, Where History Meets Science, Educational Overnight Program** and more daytime and overnight programs aboard USS *Pampanito* submarine.

SFSU DEPT. OF RECREATION, PARKS & TOURISM (Lake Merced, SF)

Patrick Tierney, <http://recdept.sfsu.edu/sailing>

Summer Youth Sailing Camps, Paddling Camps, and Sailing & Science Camps, ages 8-15. When: June 13-August 12, Monday-Friday. Paddling Camp 9 am-noon; Sailing Camp 1-4 pm; Sailing & Science Camp 9 am-4pm. Boats: Optis, JY 15s, double kayaks, SUPs (boats, boards & PFDs provided). Cost: Half day week-long camps \$135-\$149; full day week-long Science Camp \$265. Scholarships for low-income groups are available (no individual scholarships provided).

SAN FRANCISCO YC (Belvedere)

Youth Office, (415) 435-9525, youth@sfdc.org, www.sfdc.org/youth
Summer Learn-to-Sail Program, ages 7-16. When: 1-week & 2-week half-day, part-day and full-day sessions, mid-June through mid-August, Monday-Friday. Boats: Optis, JYs, CFJs, J/24s (provided).
Cost: \$225-\$795/members; \$343-\$1,155/non-members.
Race Teams, ages 8-18, all levels. When: All Year.
High School Program, grades 9-12 from Marin Academy, Marin Catholic, Branson, or Redwood High School.
When: September-May, Tuesday-Thursday, after school.
Scholarships available through the Belvedere Cove Foundation.

SANTA CRUZ YC

Skip Ely, Junior Director, (831) 750-5005, skipper@elyxir.com, www.scyc.org
El Toro Program, ages 8-14.
Where: Pinto Lake, Watsonville. When: Sundays, September-March.
Boats: El Toros (some available for charter). Cost: YC junior membership + program fee.
Scholastic Program, grades 8-12.
Where: Practice at Santa Cruz Yacht Harbor, regattas at Northern California YCs.
When: Saturdays, and select Fridays and holidays September-March. Boats: FJs.
Cost: YC junior membership + program fee; additional fee for Fridays and special holidays.
Advanced Sailing Program, grades 8-12.
Support for advanced junior sailors with their own boats.
Boats: Lasers, 29ers, and Keel boats: Melges 24, Moore 24 and SC 52.
Cost: YC junior membership + program fee.

SEA SCOUTS SAN FRANCISCO (Aquatic Park)

Dennis Lindemann, (415) 585-8825, Tamara Sokolov, (415) 517-3943, www.corsair-viking.org
Year-Round Program, ages 13-18. When: Saturdays, 9:30 am-5 pm, Tuesdays, 5-8 pm, two-week, weekend and overnight cruises.
Boats: 30-ft sailing whaleboats, FJs, Cal 20s, more. Cost: \$60/semi-annually.

SOUTH BEACH YC (San Francisco)

www.southbeachyc.org
Junior Program, ages 9-17, able to swim. 1-week sessions, 6/20-8/5, Monday-Friday, 9 am-4 pm. Boats: RS Teras, JY Trainers, Laser 4.7s, FJs (provided).
Cost: \$295/week; after 4/15, cost will increase \$20.
Scholarships available for kids in need.

SPINNAKER YC (San Leandro)

(510) 351-7905, (510) 357-0601, www.spinnakeryachtclub.org; click on Jr. Sailing
Junior Program, ages 10-18, able to swim. When: Monday-Friday, 9 am-1 pm.
See website for schedule and sign-up details. Boats: DeWitt Dinghies (provided).
Cost: \$225/San Leandro residents; \$250/non-residents.

STOCKTON SAILING CLUB

Susan Dallas, Manager; Becky Mich, Harbormaster, www.stocktonsc.org
Learn to Sail Program, ages 9-18. When: One-week classes, June-August.
Boats: Optis and FJs (provided).
Cost: Contact above; + \$15 short-term youth membership.
Summer Sleepover Sail Camp (with RYC & SCYC), www.sailcamp.org
When: July 10-16. Boats: El Toros, Optis (limited number of club boats available to rent).
Cost: \$300 + 3 shifts of parent volunteer time.
Scholarships available.

continued on page 60

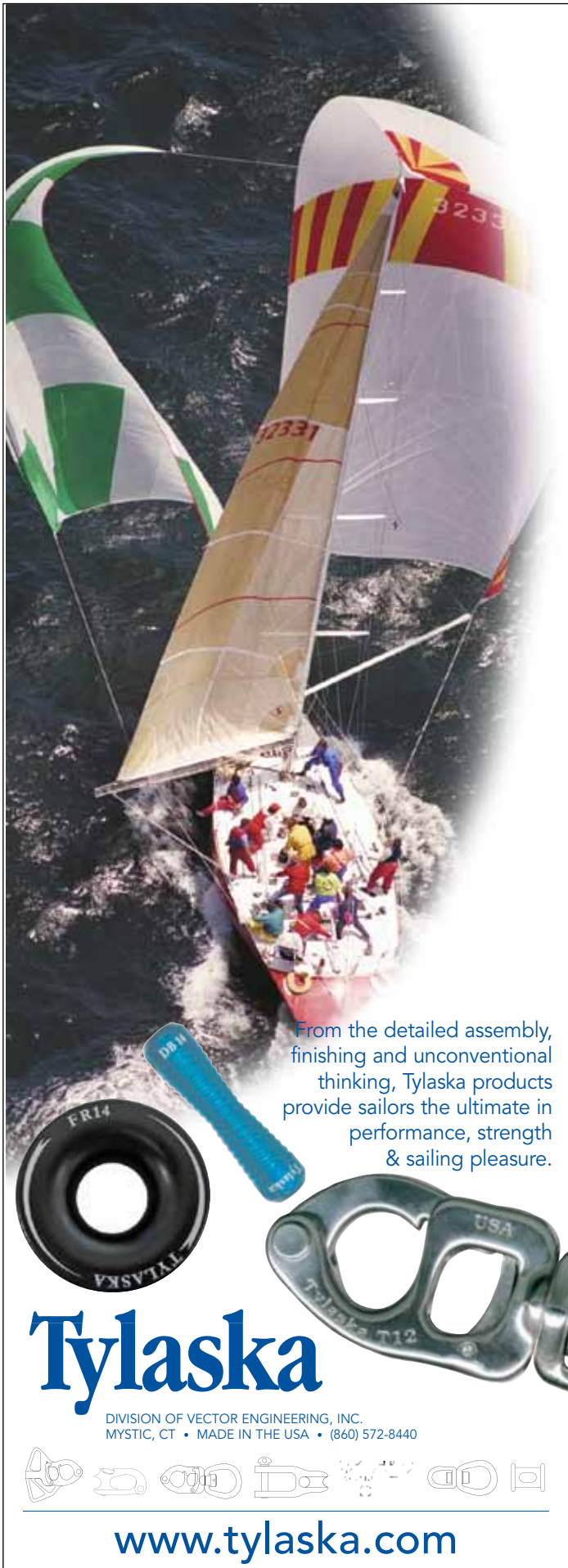

From the detailed assembly, finishing and unconventional thinking, Tylaska products provide sailors the ultimate in performance, strength & sailing pleasure.

Tylaska

DIVISION OF VECTOR ENGINEERING, INC.
MYSTIC, CT • MADE IN THE USA • (860) 572-8440

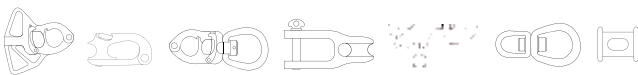

www.tylaska.com

MAY 2016

→ indicates 2-day races.
YRA events indicated in bold type.

● indicates full moon.

S	M	T	W	Th	F	S
1	2	3	4	5	6	7
8	9	10	11	12	13	14
15	16	17	18	19	20	21
22	23	24	25	26	27	28
29	30	31				

WEEKDAY & SPECIAL EVENTS

- May 14-15:**
 - PSU Invite, CGRA
 - CYC Women's Sailing Seminar
- May 27:**
 - Spinnaker Cup, SFYC/MPYC – Knox to Monterey
- May 30:**
 - Memorial Day



GOOSE GOSSMAN

SATURDAY	SUNDAY
	Elvstrom Zellerbach, StFYC – City YRA Great Vallejo Race, VYC – NB Moore 24 Regatta, SCYC 1
YRA WBRA #2, SFYC – Knox Single/Doublehanded #2, SeqYC – SB North Bay Series #2, VYC – NB Long Distance #2, SSC – Stockton Championship Series #2, CYC – Knox Cindo de Mayo Regatta, TYC – NB 7	Frank Ballentine Memorial, CPYC – SB MOTHER'S DAY 8
Elite Keel Regatta, SFYC – OC/NC → 505s, SCYC → YRA Spring #2, BYC – OC Mercury Series #3, EYC – Estuary South Bay Interclub #2, EYC – SB Singlehanded Farallones, SSS – Ocean Behrens Regatta, TYC – NB Santana 22 Team Racing, SCYC 14	Elite Keel Regatta, SFYC – OC/NC 505s, SCYC Spring Series #6, SSC – Stockton 15
USMRC Qualifier, StFYC – City → YRA OYRA Duxship – Ocean Cal Cup #2, BYC – OC Otter Cup, ElkYC – Moss Landing to Monterey & back Small Boat Races #3, EYC – Estuary Summer #2, SeqYC – SB Rosenblum Regatta, SFYC – Knox Spring One Design #2, SCYC 21	USMRC Qualifier, StFYC – City Spring Series #7, SSC – Stockton Baxter/Judson #3, PresYC – West CB SCORE #2 Regatta, SCYC 22
Easom Founders, SFYC – North OC → Whiskeytown Regatta, Whiskeytown SC → Master Mariners Regatta, SYC – City Lady and the Tramp, FLYC – Folsom Lake 28	Easom Founders, SFYC – North OC Whiskeytown Regatta, Whiskeytown SC Coastal Cup, EYC – SF to Santa Barbara 29



Delta Ditch Run

June 4, 2016



The Delta Ditch Run starts in the San Francisco Bay and goes up the Delta, finishing at Stockton Sailing Club. In the past, the Delta Ditch Run has attracted more than 200 boats with racers from across the country showing up for this generally downwind 65-mile race.

www.stocktonsc.org





VALLEJO MARINA

Gateway to the Bay & Delta



JOIN US!

We love making new friends and spoiling them!

- Competitive Rates
- Ample Guest Dock
- Full Service Boat Yard and Chandlery
- 2 Restaurants for Breakfast, Lunch, Cocktails and Dinner
- Covered and Open Berths
- Kayak Storage Now Available

2016 VALLEJO RACE Apr 30 & May 1



Race to Vallejo for Dinner!

Photo by Peter Lyons • www.lyonsimaging.com



- One hour from Sacramento
- Only three hours from Reno
- Easy access to San Francisco Bay and the Delta

(707) 648-4370

Fax (707) 648-4660 • Kimberley.Lindo@cityofvallejo.net

42 Harbor Way • Vallejo, CA 94590

www.ci.vallejo.ca.us

YOUTH SAILING

continued from page 58

TAHOE COMMUNITY SAILING / TAHOE YC / TAHOE CITY PARKS & RECREATION

Bryce Griffith, (530) 583-3440, ext. 1

Youth Sailing Program, ages 6-17. When: June-August, Monday-Thursday, 10-4.

Race Program, Laser Radial and Pico Race Teams. When: Monday evening and Friday day. Boats: CFJs, Picos, Nomad 17s, Lasers, 420s.

US Sailing Power Boat Safe Boat Handling

ADVENTURE SAILING/AQUATICS. Sailing, paddle boarding, environmental ecology, water safety. Cost: Contact above.

TREASURE ISLAND SAILING CENTER

Travis Lund, Executive Director, (415) 421-2225, www.tisailing.org

Harbor Seals Adventure Program, age 6. When: Winter: Saturdays, January 2-February 6, 9:00-12:00, \$250; Spring: Sundays, April 10-May 22, 9:00-12:00, \$300.

Summer: One Week Sessions, June 6-August 19, 9:00-4:00, \$300.

Fall: Sundays, September 11-October 23, 9:00-12:00, \$300.

Explore Sailing, ages 7-12. When: Summer: One Week Sessions, June 6-August 19, 9:00-4:00, \$350.

Beginner Youth, ages 7-12. When: Spring: Sundays, April 10-May 22, 9:00-12:00, \$350; Summer: Two Week Sessions, June 6-August 19, 9:00-4:00, \$600;

Fall: Sundays, September 11-October 23, 9:00-12:00, \$350.

Intermediate Youth, ages 7-12. When: Spring: Sundays, April 10-May 22, 1:00-4:00, \$350; Summer: Two Week Sessions, June 6-August 19, 9:00-4:00, \$600;

Fall: Sundays, September 11-October 23, 1:00-4:00, \$350.

Advanced Youth, ages 7-12. When: Spring: Sundays, April 10-May 22, 1:00-4:00, \$350; Summer: Two Week Sessions, June 6-August 19, 9:00-4:00, \$600; Fall: Sundays,

September 11-October 23, 1:00-4:00, \$350.

Beginner Teen, ages 13-18. When: Spring: Sundays, April 10-May 22, 9:00-12:00, \$350; Summer: Two Week Sessions, June 6-August 19, 9:00-4:00, \$600; Fall: Sundays,

September 11-October 23, 9:00-12:00, \$350.

Intermediate Teen, ages 13-18. When: Spring: Sundays, April 10-May 22, 1:00-4:00, \$350; Summer: Two Week Sessions, June 6-August 19, 9:00-4:00, \$600; Fall: Sundays,

September 11-October 23, 1:00-4:00, \$350.

Advanced Teen, ages 13-18. When: Spring: Sundays, April 10-May 22, 1:00-4:00, \$350; Summer: Two Week Sessions, June 6-August 19, 9:00-4:00, \$600; Fall: Sundays,

September 11-October 23, 1:00-4:00, \$350.

Jr. Big Boat I, ages 7-12. When: Winter: Saturdays, January 2-February 6, 9:00-12:00, \$250; Spring: Sundays, April 10-May 22, 9:00-12:00, \$300; Fall: Sundays, September

11-October 23, 9:00-12:00, \$300.

Jr. Big Boat II, ages 13-18. When: Winter: Saturdays, January 2-February 6, 9:00-12:00, \$250; Spring: Sundays, April 10-May 22, 9:00-12:00, \$300; Fall: Sundays,

September 11-October 23, 9:00-12:00, \$300.

Jr. Leadership Program Level 1, ages 15-18. When: Summer: Two Week Sessions, June 6-August 19, 9:00-4:00, \$300.

Jr. Leadership Program Level 2, ages 15-18. When: Summer: Two Week Sessions, June 6-August 19, 9:00-4:00, FREE.

Note: Boats Used at TISC: Bugs, Optimists, FJs, Ventures, J24s. We provide PFDs, wetsuits, foul weather gear. Scholarships: Partial or full scholarships available for all TISC Youth classes.

PACIFIC COAST INTERSCHOLASTIC SAILING ASSOCIATION (PCISA) EVENTS FOR HIGH SCHOOL SAILORS

January 2-3: Rose Bowl, PCISA 3/5, USSC/LB

January 9: So Cal #4, MBYC

January 17-18: SCYA Harold Adams Team Race, SDYC

February 6-7: SoCal #5, ABYC

February 13-14: NorCal Divisional #2, TISC

February 20-21: Golden Bear Regatta, TISC

March 12-13: Gaucho Regatta, SBYC

March 19-20: NorCal Divisional #3, HMBYC

March 26: SoCal #6, SDYC

April 2: NorCal One-Day #5, RYC

April 3: NorCal One-Day #6, RYC

April 16-17: Gold Pacific Coast Championship, SoCal venue TBA

Silver Pacific Coast Championship, EYC

April 23-24: Team Race PCCs-Baker Eliminations, SoCal venue TBA

May 13-15: Mallory Trophy ISSA Fleet Race Championship, MASSA

May 27-29: Baker Trophy ISSA Team Race Championship, MISSA

Sept.-Dec.: 2016 Fall Schedule TBA; see www.pcisa.org

NATIONAL YOUTH EVENTS

See www.ussailing.org for US Sailing info and dates.

PACIFIC COAST COLLEGIATE SAILING CONFERENCE EVENTS

See www.pccscracing.org for more information.

JUNE 2016

→ indicates 2-day races.
YRA events indicated in bold type.

● indicates full moon.

S	M	T	W	Th	F	S
5	6	7	1	2	3	4
12	13	14	8	9	10	11
19	20	21	15	16	17	18
26	27	28	22	23	24	25
			29	30		

WEEKDAY & SPECIAL EVENTS

- June 3:**
 - SoCal 300, Santa Barbara YC/SDYC – Santa Barbara to SD
- June 17-18:**
 - South Tower Race, SSC – Stockton-City-Stockton
- June 18:**
 - CGRA Opening Day
- June 18-19:**
 - Summer Sailstice
 - Poker Run & Boat Camp, FLYC – Folsom Lake
- June 20:**
 - Summer Solstice – Northern Hemisphere*
- June 24-26:**
 - Long Beach Race Week, LBYC – Long Beach
 - Woodies Invitational, StFYC, City

SATURDAY

Delta Ditch Run, SSC – RYC to SSC →
 Go For the Gold Regatta, GCYC – Scott's Flat →
YRA WBRA #3, BYC – OC
 Mercury Series #4, EYC – Estuary
 North Bay Series #3/Brothers Race, VYC – NB
 X-Bay Friendship Regatta, SBYC/CYC – Knox/CB
 Merton Yolles Memorial Race, CPYC – SB
 Wooden Boat Invitational, SYC – West Alcatraz
 Leukemia Cup, SCYC

4

SF Bay Challenge, StFYC – City →
 SC Multihulls, SCYC →
YRA OYRA Farallones Race, SFYC – Ocean
 Cal Cup #3, BYC – East Circle
 Race of Champions, SSC – Stockton
 Great SF Schooner Race, SFYC – Knox/Central
 South Bay Interclub #3, OYC – SB/Main
 Santana 22 Team Racing, SCYC

11

June Invitational, SFYC – OC →
 Opti Heavy Weather, StFYC – City →
YRA Spring Series #3, EYC – SB
 Sailstice/Small Boat Races #4, EYC – Estuary/SB
 Summer #3, SeqYC – SB
 CHISPA Regatta, EYC – Estuary
 Southern Crossing, LTWYC – Tahoe South Shore
 Spring One Design #3, SCYC

18

Woodies Invitational, StFYC – City →
YRA OYRA Half Moon Bay, HMBYC – Ocean
 Celebrate Summer Sailstice, ElkYC – Moss Landing
 Silver Eagle, IYC – CB
 Intraclub Race #2, RYC – SH
 Rear Commodore Race, SYC – Knox to SP Bay
 H.O. Lind 1-2, TYC – NB
 Hart/Nunes, SFYC – Raccoon Strait
 Katherine Eavenson Regatta, FLYC – Folsom Lake

25

SUNDAY

Delta Ditch Run, SSC – RYC to SSC
 Go For the Gold Regatta, GCYC – Scott's Flat
 Tri-Island #1, BYC – OC/Alcatraz

5

SF Bay Challenge, StFYC – City
 SC Multihulls, SCYC
 Around the Pins, LTWYC – Tahoe South Shore

12

June Invitational, SFYC – OC
 Opti Heavy Weather, StFYC – City
 Luna Race, VYC – NB
 Woman Skipper, PresYC – West CB

FATHER'S DAY

19

Woodies Invitational, StFYC – City
 Spring SCORE #3, SCYC

26



MAKING YOUR CHALLENGES OUR OWN

It's one thing to make exceptional sails, but at Quantum lofts, we go further by making your challenges our own. With personalized customer service, we're by your side as loyal advisors and fellow sailors. It's about more than superior service; it's about providing a sailing experience equipped with spirit and a thirst for the challenges ahead.

Quantum Pacific
 1230 Brickyard Cove
 Pt. Richmond, CA 94801
T 510.234.4334
E sanfrancisco@quantumsails.com

Quantum SoCal
 1620 Cowles St.
 Long Beach, CA 90813
T 562.624.4325
E socal@quantumsails.com

QUANTUMSAILS™
 TO THE NEXT CHALLENGE.
 quantumsails.com

MARINA BAY YACHT HARBOR



***SAIL FAST
HAVE FUN***

**DEEP DRAFT
RACING BERTHS**
★ ★ ★ ★
**CLOSE TO
BOATYARDS,
CHANDLERIES,
RIGGERS AND
SAIL LOFTS**



Come Home to Marina Bay

**CONVENIENT
ACCESS
TO THE
WORLD'S
BEST
RACING!**



NEW HOME OF

Strictly Sail
PACIFIC

Make Marina Bay Your Race Headquarters

(510) 236-1013 • www.MarinaBayYachtHarbor.com

EL TORO FOR A LIFETIME



Joc, Chris, Nick and Sam Nash – Four generations sail El Toros.

2016 EL TORO CLASS SCHEDULE

SENIOR:

RYC WINTER SERIES	1/3, 2/7, 3/6	TOTALLY DINGHY	SEPTEMBER 24
LAKE MERRITT/ESTUARY ...	1/10, 2/13, 3/13	STAMPEDE	OCTOBER 9
BULLSHIP	MARCH 26	CORK SCREW	OCTOBER 22
FLIGHT OF THE BULLS	MAY 7	JUNIOR:	
FREMONT RELAYS	MAY 15	FREMONT SPRING	MAY
LAKE MERRITT, MAYOR'S CUP	JUNE	LAKE MERRITT MAYOR'S CUP	JUNE
CLEAR LAKE	JUNE 18-19	STOCKTON, JR. NAS	JULY 15
PINECREST NATIONALS	AUGUST 3-5	SANTA CRUZ, FUN REGATTA	SEPTEMBER
PINECREST WORLDS	AUGUST 6-7	RICHMOND, STAMPEDE	OCTOBER 9

91 Waldo Point S-40, Sausalito, CA 94965
etirya@comcast.net • ggcnjr@gmail.com

www.eltoroyra.org • (415) 332-7269

Berkeley Yacht Club Oktoberfest Regatta 2016



**Saturday
Oktober 15th**

Details at: www.Berkeleyytc.org

JULY 2016

→ indicates 2-day races.

YRA events indicated in bold type.

● indicates full moon.

S	M	T	W	Th	F	S
					1	2
3	4	5	6	7	8	9
10	11	12	13	14	15	16
17	18	19	20	21	22	23
24	25	26	27	28	29	30
31						

WEEKDAY & SPECIAL EVENTS

- July 4:**
 - Independence Day
 - Independence Cup, SFYC – Knox
 - Brothers & Sisters Race, TYC – NB
 - Fouth of July Regatta, EYC – Estuary
- July 5-8:**
 - WIND Youth Clinic, CGRA
- July 9-10:**
 - WIND Youth Regatta, CGRA
- July 11-13:**
 - 29er US Sailing Training Camp, CGRA
- July 11-16:**
 - Pacific Cup, BYC – Ocean
- July 15-17:**
 - Melges 24 PCCs, StFYC – City
 - Gorge Skiff Regatta, CGRA
- July 16-19:**
 - Gorge Laser Performance Clinic, CGRA
- July 20:**
 - Laser Gorge Blowout, CGRA
- July 21-24:**
 - Laser North Americans, CGRA
- July 29-31:**
 - Columbia Gorge One-Design Regatta (CGOD), CGRA
 - Santana 22 Nationals, SCYC

SATURDAY	SUNDAY
Firecracker Race, ElkYC – Moss Landing to Monterey & back Singlehanded TransPac, SSS – Ocean North Bay #4, VYC – NB Stars and Stripes, CPYC – SB	
2	3
BAYS Svendsen's Summer Splash, EYC – Estuary → SF Classic & UN Challenge, StFYC – City → Cal 20 Round Robin, CYC – Raccoon → High Sierra Centerboard Regatta, GCYC – Huntington Lake → YRA Westpoint Regatta, SeqYC – SB South Bay Interclub #4, SBYC – SB PICYA Lipton Cup, SYC – SB Santana 22 Team Racing, SCYC	BAYS Svendsen's Summer Splash, EYC – Estuary SF Classic & UN Challenge, StFYC – City Cal 20 Round Robin, CYC – Raccoon High Sierra Centerboard Regatta, GCYC – Huntington Lake Tri-Island Race #2, BYC – OC/TI Howard Stevens Race, LTWYC – Tahoe South Shore
9	10
Melges 24 PCCs, StFYC – City → Monterey & Back, SCYC → Bay Bridge Regatta, SBYC – SB/SF → High Sierra Keelboat Regatta, GCYC – Huntington Lake → YRA OYRA Jr. Waterhouse, RYC – Ocean Twin Island Race #2, SYC – Knox/Alcatraz Plastic Classic, BVBC – SB/SF Small Boat Races #5, EYC – Estuary Jack and Jill Race, SSC – Stockton Midnight Moonlight Maritime Marathon, SFYC – Raccoon to Carquinez & back Championship Series #3, CYC – Knox	Melges 24 PCCs, StFYC – City Monterey & Back, SCYC Bay Bridge Regatta, SBYC – SB/SF High Sierra Keelboat Regatta, GCYC – Huntington Lake Baxter/Judson #4, PresYC – West CB
16	17
One Design Invitational, CYC – North OC → YRA Summer Series #1, SBYC – SB Mitchell/Ross Regatta, SFYC – Knox Sailor's Choice Summer Mini Series #1, ElkhornYC – Moss Landing Single/Doublehanded #3, SeqYC – SB H.O. Lind 3-4, TYC – NB Centerboard Regatta, FLYC – Folsom Lake	One Design Invitational, CYC – North OC Sir Francis Chichester Race, EYC – SB/Estuary Doublehanded Races, LTWYC – Tahoe South Shore
23	24
YRA 2nd Half Opener, EYC – CB/Bonita → Multihull Regatta, SFYC – North OC →	YRA 2nd Half Opener, EYC – CB/Bonita Multihull Regatta, SFYC – Knox
30	31

32nd Annual

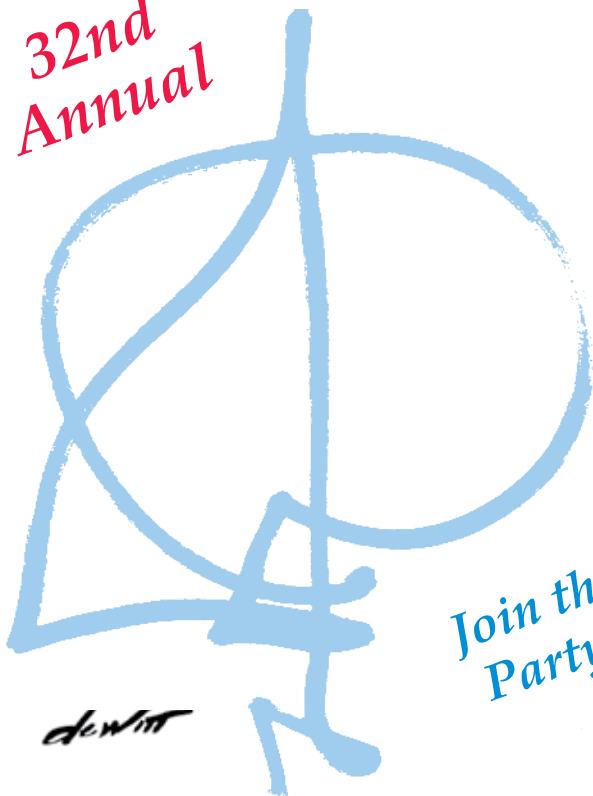

Join the Party!

THE BAY VIEW BOAT CLUB AND THE ISLANDER BAHAMA FLEET invite all

'60s, '70s & '80s Vintage Fiberglass Sailboats

to the San Francisco

PLASTIC CLASSIC REGATTA

and *Concours d'Elegance*

Saturday, July 16

at the Bay View Boat Club and the waters of Pier 54.

Visit our website: www.bvbc.org

Bay View Boat Club, 489 Terry Francois Blvd., San Francisco, CA 94158

www.plasticclassic.com

VHF RADIO CHANNEL USES

CH. #	INTENDED USE
16	Distress, safety , calling. Monitored by the Coast Guard and public coast stations.
6	Intership safety purposes and search and rescue (SAR) communications. Not to be used for non-safety matters.
12	Offshore Vessel Movement Reporting System. In use from Pilot Boarding Precautionary Area Approach buoys N, W and S to outer limits of System (N 41 nm, W 29 nm, S29 nm).
13	Bridge to Bridge commercial vessel navigation and safety communications. In use from the Offshore Pilot Boarding Precautionary Area (buoy SF #1 – Sea Buoy) to inside the Bay and throughout the Delta regions.
14	Vessel Traffic Service (VTS). Power Driven Vessels (40+ meters), Passenger Vessels (50+ passengers), Towing Vessels (8+ meters w/tow), Marine Events (committee boat, organizer). Check in, MONITOR , update, check out.
22A	U.S. Coast Guard Communications with USCG stations, vessels and aircraft after contact on channel 13 or 16.
7A, 8, 9, 10, 11, 18A, 19A, 79A, 80A, 88A	Port Operations. Commercial (intership and ship to coast) working channel. Commercial vessel business and operational needs.
9, 68, 69, 71, 72, 77A, 78A	Port Operations. Commercial (intership and ship to coast) working channel. Supplies, repairs, berthing, yacht harbors, marinas. These are the channels used by race committees.
26, 84, 87, 27, 28, 86, 25, 26, 27, 28, 28	Marine Radio-Telephone Operators San Francisco Sacramento, Stockton, Delta North: Bodega Bay to Fort Bragg and 50 miles out South: Santa Cruz to Point Sur and 50 miles out
12, 20, 65A, 66A, 73, 74	Coast Guard Port Operations. Traffic advisory for use by agencies directing movements of vessels in or near ports. Offshore Vessel Movement Reporting System.
WX 1-2-3	Weather (receive only).

Of all the safety equipment on your boat, your VHF radio is probably the most effective and essential. Because VHF uses common frequencies, it's important to remember a few rules of marine radio etiquette:

- Radio checks, which should be performed at least every time you leave your slip, should always be conducted on channel 9, never on channel 16.
- Before hailing another station on channel 16, listen for at least one minute before keying your mic, so as not to “step” on radio traffic that’s already underway.
- Speak slowly and pause for at least a minute between hailing attempts.
- Always start on the “low” power setting.
- Don’t use the radio if you have non-emergency traffic that can be accomplished with a mobile phone.

Mark your calendar for an exciting 2017!

The Storm Trysail Club brings you two exciting events:

Quantum Key West Race Week 2017

January 15–20, 2017

January’s Best ... in Key West!

Come and experience an exceptional week of international racing excitement and shoreside fun at the world-class venue that is Key West, Florida. One Design, ORC and IRC fleets featuring the latest designs from around the world will come together for championship caliber competition.

For invited classes, planning details and updates visit:

www.keywestraceweek.com

Block Island Race Week 2017

June 18–23, 2017

The 51st Block Island Race Week is scheduled for June 18-23, 2017 and includes multiple races per day, lots of shoreside activities, and a Round the Island Race. This iconic East Coast sailing regatta organized by the Storm Trysail Club attracts a high caliber of sailing competitors... you should be there too!

For invited classes, planning details and updates visit:

www.blockislandraceweek.com

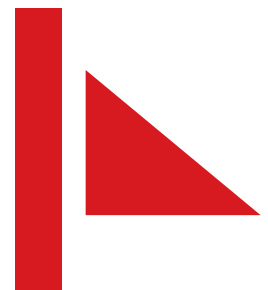

STORM
TRYSAIL
CLUB

AUGUST 2016

→ indicates 2-day races.
YRA events indicated in bold type.

● indicates full moon.

S	M	T	W	Th	F	S
	1	2	3	4	5	6
7	8	9	10	11	12	13
14	15	16	17	18	19	20
21	22	23	24	25	26	27
28	29	30	31			

WEEKDAY & SPECIAL EVENTS

- August 9:**
 - Cup Boat Regatta, FLYC – El Dorado Hills
- August 9-11:**
 - RS Aero Pre-Regatta Clinic, CGRA
- August 12:**
 - RS Aero Gorge Blowout, CGRA
- August 12-14:**
 - Summer Keel/Melges 24 PCCs, SFYC – OC
- August 13:**
 - HRYC Double Damned, CGRA
- August 13-14:**
 - RS Aero PCCs, CGRA
- August 19-21:**
 - Aldo Alessio Perpetual, StFYC – City
- August 22-27:**
 - 18-ft Skiff Regatta, StFYC – City
- August 25-26:**
 - O'pen Bic Gorge Sailing Camp, CGRA
- August 26:**
 - Ronstan Bridge to Bridge, StFYC – City
- August 27-28:**
 - O'pen Bic UnRegatta, CGRA

SATURDAY

BAYS #4, SFYC – Richardson Bay →
YRA WBRA #4, CYC – Knox
YRA OYRA RC's Choice, BYC – Ocean
North Bay Series #5/Angel Island Race, VYC – NB
Sailor's Choice Summer Mini Series #2,
SeqYC – Moss Landing
Fox Hat Race, TYC – NB
Moseley Regatta, TYC – NB
Kay & Dave Few Regatta, CPYC – SB

6

Summer Keel/Melges, SFYC – North OC →
Steele Cup/Dinghy Weekend, FLYC – Rancho Seco →
YRA Summer Series #2, RYC – SH
Cal Cup #4, BYC – OC
South Bay Interclub #5, BAMA – SB
Santana 22 Team Racing, SCYC

13

Special Olympics NorCal Regatta, BYC – OC/CB →
Round the Rock, BVBC – SB/SF
Wooden Boat Invitational #2, SYC – West Alcatraz
Sailor's Choice Summer Mini Series #3, SeqYC – Moss Landing
Small Boat Races #6, EYC – Estuary
Intraclub Race #3, RYC – SH
Moonlight Marathan, SeqYC – SB/TI
H.O. Lind 5-6, TYC – NB
Wosser Cup, SFYC – Knox
Championship Series #4, CYC – Knox
Fall One Design #1, SCYC
Singlehanded Regatta, FLYC – Folsom Lake

20

Corinthian Cup, SFYC – North OC →
YRA OYRA/SSS Drake's Bay I, CYC – Ocean →
Summer #4, SeqYC – SB
Double Angle, ElkYC/SCYC – Santa Cruz/Monterey Bay
Women's Skippers Regatta, SYC – Knox

27

SUNDAY

BAYS #4, SFYC – Richardson Bay
Commodores Cup, LTWYC – South Tahoe
Big Brothers Big Sisters Regatta, SCYC

7

Summer Keel/Melges, SFYC – North OC
Steele Cup/Dinghy Weekend, FLYC – Rancho Seco
Tri-Island Race #3, BYC, OC/Angel
Ladies Day Race, LTWYC – Tahoe South Shore

14

Special Olympics NorCal Regatta, BYC – OC/CB
Gracie & George Regatta, EYC – SB/Estuary
Baxter/Judson #5, PresYC – West CB
Singlehanded Races, LTWYC – Tahoe South Shore

21

Corinthian Cup, SFYC – North OC
YRA OYRA/SSS Drake's Bay II, CYC – Ocean
Fall SCORE #1, SCYC – Start ElkYC

28

South Beach Yacht Club 2016 Racing Season



**For the best sailing
on the South Bay,
come race with SBYC!**

All Boats Welcome

One Design Starts Available
(minimum entry requirements)

Post-race activities include BBQ & no-host bar.
Prizes awarded for all divisions.

Racing contact:

rearcommodore@southbeachyachtclub.org

or visit our Web site at:

www.southbeachyachtclub.org

South Beach Yacht Club
Pier 40 on the Embarcadero
San Francisco



2016 Island Fever Races:

1/23, 2/27, 3/19, 11/19, 12/17

Friday Night Series: April 15–August 26

SBYC/CYC/SYC X-Bay Regatta: June 4

SBYC Bay Bridge Regatta: July 16-17

Jazz Cup: September 3

Herb Meyer Regatta: September 24-25

Red Bra Regatta: October 1

Winter California Style

BERKELEY MIDWINTERS

Where the heat is on all winter long!

The longest running winter series on the Bay.

New set-marks to avoid shallow water!

Separate Saturday and Sunday series!

G. Second weekend of the month from November through February!

F. Enter them both and use the BYC guest dock overnight.

B.

C.

D.

E.

XOC.

Check out www.berkeleyyc.org for Notice of Race, Entry Form, Sailing Instructions, results and much, much more. Call or email for more information

Bob Gray
(510) 530-4162
r_gray40@sbcglobal.net

Bobbi Tosse
(925) 939-9885
bobbi@jfcbat.com



Express 37

One of Carl Schumacher's breakthrough designs, the Express 37 has been one of the most successful one design fleets on the Bay for over 25 years.

Contact:
Dave Fullerton
(650) 458-3324
www.express37.net

Join us for our **26th ROLEX BIG BOAT SERIES & 31st NATIONAL CHAMPIONSHIP REGATTA**

JOIN US

36

Islander 36 Association

*Fun Racing, Comfortable Cruising,
Great Friends, Active One-Design Fleet.*



Spring Meeting, March 19, Golden Gate YC
Curious? Visit: www.islander36.org
Racer? Fleet Captain Eric Mueller - racing@islander36.org
Cruiser? Cruise Captain Bob DaPrato - cruising@islander36.org

S22 ANTANA

JOIN US FOR THE 2016 **S22 NATIONALS** July 29-31 Santa Cruz YC



www.santana22.org

- ◆ Tight, tactical one design racing
- ◆ Mentor program for new members
- ◆ New boats now in production, but old boats just as fast
- ◆ Non-spinnaker and spinnaker races, cruise-ins and parties
- ◆ The best bang for the buck on the Bay!

co-fleet captains Kristen Soetebier & Deb Fehr
Santana22sfbay@gmail.com

SEPTEMBER 2016

● indicates full moon.

→ indicates 2-day races. **YRA events indicated in bold type.**

S	M	T	W	Th	F	S
				1	2	3
4	5	6	7	8	9	10
11	12	13	14	15	16	17
18	19	20	21	22	23	24
25	26	27	28	29	30	

WEEKDAY & SPECIAL EVENTS	SATURDAY	SUNDAY
<p>September 2: • Windjammers, StFYC/SCYC – SF to Santa Cruz</p> <p>September 5: • <i>Labor Day – Take a worker sailing</i></p> <p>September 3-10: • International Knarr Championships, StFYC – City</p> <p>Sept. 5-11: • IOD Worlds, SFYC – OC</p> <p>September 7: • Latitude 38 Mexico-Only Crew List Party, 6-9 pm., Encinal YC. See Latitude 38 or www.latitude38.com.</p> <p>September 15-18: • Rolex Big Boat Series, StFYC – City</p> <p>September 22: • <i>Autumnal Equinox</i></p> <p>September 23-25: • 505 PCCs, StFYC – City</p> <p>September 24-25: • Women's Sailing Seminar, IYC – Estuary</p> <p>Sept. 24-Oct. 2: • J/70 Worlds, StFYC – City</p>	<p>Perpetual Day 1, LTWYC – Tahoe South Shore → Jazz Cup, SBYC/BYC – CB to Benicia North Bay Series #6, VYC – NB</p> <p style="text-align: right;">3</p> <p>Millimeter Nationals, EYC – Estuary → Multihull Regatta, RYC – SH → West Marine Fun Regatta, SCYC → YRA OYRA RC's Choice – Ocean Cal Cup #5, BYC – OC Singlehanded/Doublehanded #4/Commodore's Cup, SeqYC – SB Wooden Boat Invitational #3, SYC – West Alcatraz South Bay Interclub #6, OYC – SB Fall Race #1, SSC – Stockton</p> <p style="text-align: right;">10</p> <p>Bart's Bash – Global Sailing Event → YRA Summer Series #3, SBYC – SB Tornberg Regatta, TYC – NB Fall One Design #2/Melges, SCYC</p> <p style="text-align: right;">17</p> <p>Herb Meyer Regatta, SBYC – SB/SF → YRA Season Closer, CYC – CB → Half Moon Bay, SSS – Ocean</p> <p style="text-align: right;">24</p>	<p>Perpetual Day 2, LTWYC – Tahoe South Shore Governor's Cup Series #1, FLYC – Folsom Lake</p> <p style="text-align: right;">4</p> <p>Millimeter Nationals, EYC – Estuary Multihull Regatta, RYC – SH West Marine Fun Regatta, SCYC Commodore's Cup, EYC – Estuary Governor's Cup Series #2, FLYC – Folsom Lake Late Summer Race, LTWYC – Tahoe South Shore</p> <p style="text-align: right;">11</p> <p>Bart's Bash – Global Sailing Event Small Boat Races #7, EYC – Estuary Governor's Cup Series #3, FLYC – Folsom Lake Baxter/Judson #6, PresYC – West CB Fannette Isle Race, LTWYC – Tahoe South Shore</p> <p style="text-align: right;">18</p> <p>Herb Meyer Regatta, SBYC – SB/SF YRA Season Closer, CYC – CB Totally Dinghy, RYC – SH Governor's Cup Series #4, FLYC – Folsom Lake Women's Sailing Seminar Regatta, IYC – Estuary Fall SCORE #2, SCYC</p> <p style="text-align: right;">25</p>

BOAT LOANS

from

Trident Funding

"a fresh approach from people you can trust"

JOAN BURLEIGH
(800) 690-7770

Loans will be arranged or made pursuant to a California Finance Lenders License #605 1871.

WOMEN'S CIRCUIT

The events on this page constitute *Latitude 38's* unofficial Women's Circuit. We challenge women sailors to take the helm and create their own series of events from this list. You don't need to finish first to win, and you don't need to do all the races on the list either! Just send proof of your participation in as many events as you can to chris@latitude38.com, or fax it to (415) 383-5816, by November 12, 2016, and you could be crowned *Latitude's* 'Queen of the Women's Circuit'.

Sunday, February 28

Sadie Hawkins Race, IYC
John New, (510) 521-2980, iycracing@iyc.org,
www.iyc.org

Saturday, March 12

Rites of Spring (division for all-female crews), OYC
Jim Hild, (510) 277-4676, oycracecom@gmail.com,
www.oaklandyachtclub.com

Saturday, May 28

Lady and the Tramp Race, FLYC
www.flyc.org

Sunday, June 19

Woman Skippers Race, PresYC
(415) 677-7917
www.presidiyachtclub.org

Saturday, July TBD

Sadie Hawkins, KBSC
Check website for information:
www.kbsail.com

Saturday, July 16

Jack and Jill Race, SSC
(209) 951-5600, regatta16@stocktonsc.org,
www.stocktonsc.org

Saturday, August 6

Kay & Dave Few Regatta, CPYC
(650) 347-6730, regatta@cpyc.com,
www.cpyc.com

Sunday, August 14

Ladies' Day Races, LTWYC – South Lake Tahoe
David Young, (530) 545-9155
ltwyc2@aol.com,
www.tahoewindjammers.com

Sunday, August 21

Gracie & George Regatta, EYC
Doug Perry, (510) 867-8064,
svchoices@att.net,
www.encinal.org

Saturday & Sunday, September 24-25

Women's Sailing Seminar
(race Sunday), IYC
John New, (510) 521-2980, iycracing@iyc.org,
www.iyc.org

Sunday, September TBD

Jack and Jill Regatta, SCYC
cyc@scyc.org, www.scyc.org

Sunday, September TBD

Jack & Jill, KBSC
Check website for information:
www.kbsail.com

Saturday, October 1

Red Bra Regatta, SBYC
Dan Courter, (925) 209-3081
rearcommodore@southbeachyachtclub.org,
www.southbeachyachtclub.org

Saturday, October 15

Joan Storer Regatta, TYC
race@tyc.org,
www.tyc.org

Sunday, November 6

Jack & Jill + 1
(woman skipper triplehanded race), IYC
John New, (510) 521-7442,
iycracing@iyc.org,
www.iyc.org



FRED FAGO

OCTOBER 2016

→ indicates 2-day races.

YRA events indicated in bold type.

● indicates full moon.

S	M	T	W	Th	F	S
						1
2	3	4	5	6	7	8
9	10	11	12	13	14	15
● 16	17	18	19	20	21	22
23	24	25	26	27	28	29
30	31					

WEEKDAY & SPECIAL EVENTS

- Sept. 24-Oct. 2:** • J/70 Worlds, StFYC – City
- Oct. 4-8:** • Etchells North Americans, SFYC – OC
- October 7-9:** • Express 37 Nationals, BYC – OC/CB
• Sportboat Invitational, RYC – OC
- October 10:** • *Columbus Day*
- October 20-21:** • Kilroy Pro Am, StFYC – City
- October 30:** • Baja Ha-Ha starts, SD – Cabo
- October 31:** • *Halloween: Go sailing in costume!*

SATURDAY

BAYS HS NorCal Regatta, EYC – Estuary →
Champions Race, BenYC – Carquinez
Summer #5, SeqYC – SB
Champion of Champions, VYC – NB
Shorthanded Races, TYC – NB
Red Bra Regatta, SBYC – SB/SF side
Oktoberfest, OYC – TI/Estuary
Jerry O'Grady Singlehanded Race, CPYC – SB
Auxiliary Cup, SFYC – Knox

505s, SCYC →
YRA WBRA #6 – City
Champion of Champions, BVBC – SB/SF
Chowder Cup #1, ElkYC – Moss Landing
El Toro Stampede, RYC – Potrero Reach
Challenge Race, SeqYC/LGYC – SB
Fall Series #2, SSC – Stockton

Fall Classic, SFYC – Knox →
Oktoberfest, BYC – OC
Singlehanded/Doublehanded #5/Commodore's Cup,
SeqYC – SB
Jessica Cup, StFYC – City
Twin Island Race #3, SYC – Knox/Alcatraz
Fall Shorteez Regatta; PHRF 180+, CPYC – SB
Joan Storer Regatta, TYC – NB
Ross Wood CC #5, CYC – Knox
Interclub #4, RYC – SH
Fall One Design #3, SCYC

Vallejo 1, SSS – OC/Vallejo →
Fall Dinghy, StFYC – City →
Leukemia Cup, SFYC – City or Alcatraz →
Corkscrew Slough Regatta, SeqYC – SB
South Bay Championship, SeqYC – SB
Chowder Cup #2, ElkYC – Moss Landing

Great Pumpkin, RYC – OC →
Round the Island, SFYC – Belvedere/TI/SH

SUNDAY

BAYS HS NorCal Regatta, EYC – Estuary
Chowder #1, BYC – OC

505s, SCYC
Chowder #2, BYC – OC

Fall Classic, SFYC – Knox
Chowder #3, BYC – OC

Vallejo 2, SSS – VYC/RYC
Fall Dinghy, StFYC – City
Leukemia Cup, SFYC – Knox
Chowder #4, BYC – OC
Fall SCORE #3, SCYC

Great Pumpkin, RYC – OC
Chowder #5, BYC – OC

IT STARTS WITH A FIASCO, AND COULD TAKE YOU TO HAWAII

SHORTHANDED SAILING IN THE BAY AND THE OCEAN

2016 Race Dates:

- Three Bridge Fiasco - Jan. 30
- Corinthian - Mar. 19
- Round the Rocks - Apr. 23
- Singlehanded Farallones - May 14
- Drake's Bay - Aug. 27-28
- Half Moon Bay - Sept. 24
- Vallejo 1-2 - Oct. 22-23



JOIN US IN 2016!

SHTP SEMINARS: Scheduled for the
2nd Wednesday of each month
January-June 2016; 7:30 PM, Oakland YC

TOPICS INCLUDE: Rigging and Sails,
E-Rudders, Return Trip, Communications,
Provisioning & Medical, Weather & Strategy

www.sfbaysss.org/shtp2016/seminars



SINGLEHANDED
SAILING SOCIETY

Singlehanded TransPac
Starts July 2, 2016
2,120 miles. Ends in Hanalei Bay, Kauai

Complete SSS schedule here: www.sfbaysss.org

2016-2017 PACIFIC OCEAN EVENTS

HAWAII & SOUTH PACIFIC

TAHITI PEARL REGATTA • May 2-7, 2016
International fleet racing in the Leeward Islands of Tahiti.
www.tahitipearlregatta.org.pf

TRANSPACIFIC YACHT RACE • Mid-June 2016
Los Angeles to Tahiti. www.transpacrace.com

VIC-MAUI • July 2016
2,300 miles from Victoria, BC, to Maui, Hawaii. www.vicmaui.org

PACIFIC CUP • starts July 11, 2016
San Francisco to Kaneohe Bay, Oahu, Hawaii. www.pacificcup.org

MEXICO

PV RACE • February 19-27, 2016
1,100-mile slide from San Diego to Puerto Vallarta. www.sdy.org/pv

BANDERAS BAY REGATTA • March 9-12, 2016
Music, fun, and racing specially designed for cruisers on Banderas Bay.
www.banderasbayregatta.com

NEWPORT TO ENSENADA • April 22-24, 2016
Newport Beach to Ensenada, Baja California.
www.newporttoensenada.com

NEWPORT TO CABO RACE • March 2017
Newport Beach to Cabo San Lucas, Baja California Sur.
www.nhyccaborace.com

AUSTRALIA & NEW ZEALAND

BAY OF ISLANDS SAILING WEEK • January 26-29, 2016
Buoy racing in New Zealand's Bay of Islands.
www.bayofislandssailingweek.org.nz

AUDI HAMILTON ISLAND RACE WEEK • August 20-27, 2016
Racing and partying in Australia's Whitsunday Islands.
www.hamiltonislandraceweek.com.au

AUSTRALIA & NEW ZEALAND cont'd

COASTAL CLASSIC AUCKLAND TO RUSSELL YACHT RACE
Late October 2016
Point to point race from Auckland to Russell in N.Z.'s Bay of Islands.
www.coastalclassic.co.nz

ROLEX SYDNEY HOBART YACHT RACE • December 2016
World's preeminent middle-distance race – 628 miles from Sydney Harbour to the Derwent River, Australia.
www.rolexsydneyhobart.com

ASIA

ROYAL LANGKAWI INTERNATIONAL REGATTA • January 11-16, 2016
Large buoy racing regatta for everything from IRC divisions to multihulls.
www.langkawiregatta.com

SUBIC BAY TO BORACAY RACE • February/March 2016
200-mile race from Subic Bay to Boracay, Philippines.
www.subicsailing.com

BORACAY CUP REGATTA • March 2016
Following the offshore Race from Subic Bay, the Boracay Cup gets underway with two days each of windward/leeward courses and round-the-island courses. www.subicsailing.com

ROLEX CHINA SEA RACE • March 23, 2016
565-mile race from Hong Kong to Subic Bay, Philippines.
www.rhkyc.org.hk/rolexchinasearace.aspx

CHINA CUP INTERNATIONAL REGATTA • October/November 2016
The world's newest and most ambitious yachting festival, held in the southern city of Shenzhen. www.chncup.com

PHUKET KING'S CUP • Late November–Early December
Five days of racing at Thailand's biggest event.
www.kingscup.com



PACIFIC CUP

the FUN race to Hawaii • July 2016

PREPARATION AND PARTIES — FUN! FUN! FUN!

Alaska Airlines Pacific Offshore Academy* • January 23 and March 26

Special Medical Seminar* • February 13

Safety at Sea Seminar* • May 14 and 15, Encinal Yacht Club

Pacific Cup Village at RYC opens • Saturday, July 2

Sponsor Party • Tuesday, July 5

Alaska Airlines Extravaganza • Thursday, July 7

Skippers Meeting & BMW of San Rafael Bon Voyage Party • Saturday, July 9

**Pre-registration required. Please check the website for details and additional events.*

FIRST RACE START JULY 11

www.PacificCup.org

NOVEMBER 2016

● indicates full moon.

S	M	T	W	Th	F	S
6	7	8	9	10	11	12
13	14	15	16	17	18	19
20	21	22	23	24	25	26
27	28	29	30			

→ indicates 2-day races. YRA events indicated in bold type.

WEEKDAY & SPECIAL EVENTS

- November TBD:**
- YRA Year-End Trophy Party – BYC
 - Turkey Shoot, LWSC – Lake Washington
- November 11:**
- Veterans Day. Take a veteran sailing!
- November 24:**
- Thanksgiving Day
- November 25:**
- Wild Turkey Race, TYC – NB

SATURDAY

Opti Winter #1, SFYC – Richardson Bay →
 Seaweed Soup Midwinter #1, GGYC – City
 Winter #1, SeqYC – SB
 Commodore's Cup, CPYC – SB
 Fall Race #3, SSC – Stockton
 Chowder Cup #3, ElkYC – Moss Landing
 Red Rock Race, TYC – NB

5

Midwinter #1, BYC – OC
 Jack Frost #1, EYC – Estuary
 Santana 22 Team Racing, SCYC

12

Redwood Cup #1, SeqYC – SB
 Island Fever #1, SBYC – SB
 Chowder Cup #4, ElkYC – Moss Landing
 Midwinter #1, SCYC

19

Commodore's Challenge, IYC – Estuary

26

SUNDAY

Opti Winter #1, SFYC – Richardson Bay
 Jack & Jill + 1, IYC – Estuary
 Midwinter #1, SYC – Knox
 Chowder #6, BYC – OC
 Laser Short Course, RYC

DAYLIGHT SAVING TIME ENDS

6

Midwinter #2, BYC – OC
 Island Days Midwinter #1, IYC – Estuary

13

Chowder #7, BYC – OC

20

Chowder #8, BYC – OC

27



FRED BROWN

PERFORMANCE RIGGING

Located
 BERKELEY
 MARINE CENTER

Wire and Rod Standing Rigging • Running Rigging
 Architectural Rigging

Offshore / Inshore
 High performance rigging
 and deck layouts.

BUTLER RIGGING
 butlerrigging@sbcglobal.net
 (510) 672-2639 • (510) 665-4744

BSI RIGGING • NEW ENGLAND ROPES • SCHAEFER

Robichaud Batten Systems USA



Quality.
Durability.
Performance.



Trusted and preferred by
these Bay Area Sail Makers:

North Sails Quantum Sails
Pineapple Sails Doyle Sails
Hogin Sails Ullman Santa Cruz
UK-Halsey Sails Pegasus Racing

Visit us at www.rbsbattens.com
for more info on new products.

**LOOK
GOOD...
SAIL
FAST!**



(We'll handle the first part!)

10% Discount for scheduling 30+ days in advance

(Due to high demand prior to big events,
we've been unable to accommodate everyone.)

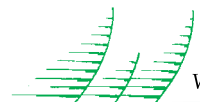

Westwind

Washing, waxing, varnishing, and interior cleaning.

Serving the entire Bay Area for more than 25 years

Pier 40, South Beach on the Embarcadero • San Francisco

(415) 661-2205 • www.boatdetailing.com

2016 SUNRISE AND SUNSET

As observed from sea level at the Golden Gate Bridge

Pacific Standard Time

Corrected for Daylight Saving Time

	RISE	SET		RISE	SET
JANUARY			JULY		
1	7:25	17:01	1	5:52	20:35
5	7:25	17:05	5	5:54	20:35
10	7:25	17:09	10	5:57	20:33
15	7:24	17:14	15	6:00	20:31
20	7:22	17:20	20	6:04	20:28
25	7:19	17:25	25	6:08	20:24
30	7:16	17:31	30	6:12	20:20
FEBRUARY			AUGUST		
1	7:14	17:33	1	6:14	20:18
5	7:10	17:37	5	6:17	20:13
10	7:05	17:43	10	6:21	20:08
15	7:00	17:48	15	6:26	20:02
20	6:54	17:54	20	6:30	19:55
25	6:47	17:59	25	6:34	19:48
			30	6:39	19:41
MARCH			SEPTEMBER		
1	6:40	18:04	1	6:40	19:38
5	6:35	18:08	5	6:44	19:32
10	6:27	18:13	10	6:48	19:24
15	7:20	19:17	15	6:52	19:17
20	7:12	19:22	20	6:56	19:09
25	7:05	19:27	25	7:01	19:01
30	6:57	19:31	30	7:05	18:53
APRIL			OCTOBER		
1	6:54	19:33	1	7:06	18:52
5	6:48	19:37	5	7:09	18:46
10	6:41	19:41	10	7:14	18:38
15	6:34	19:46	15	7:19	18:31
20	6:27	19:51	20	7:23	18:25
25	6:20	19:55	25	7:28	18:18
30	6:14	20:00	30	7:34	18:13
MAY			NOVEMBER		
1	6:13	20:01	1	7:36	18:10
5	6:09	20:04	5	7:40	18:06
10	6:04	20:09	10	6:45	17:02
15	5:59	20:13	15	6:51	16:58
20	5:56	20:17	20	6:56	16:55
25	5:52	20:21	25	7:01	16:53
30	5:50	20:25	30	7:06	16:51
JUNE			DECEMBER		
1	5:49	20:26	1	7:07	16:51
5	5:48	20:29	5	7:11	16:51
10	5:47	20:31	10	7:15	16:51
15	5:47	20:34	15	7:18	16:52
20	5:48	20:35	20	7:21	16:54
25	5:49	20:36	25	7:23	16:57
30	5:51	20:36	30	7:25	17:00

This table may be used in the vicinity of the stated location with less than a 2-minute error.

Latitude 38

2016 Sailing Calendar and YRA Master Schedule

Publisher/Exec. Editor	Richard Spindler	richard@latitude38.com	ext. 111
Associate Publisher	John Arndt	john@latitude38.com	ext. 108
Managing Editor	Andy Turpin	andy@latitude38.com	ext. 112
Racing Editor	Christine Weaver	chris@latitude38.com	ext. 103
Advertising Sales	John Arndt	john@latitude38.com	ext. 108
Advertising Sales	Mike Zwiebach	mikez@latitude38.com	ext. 107
General Manager	Colleen Young	colleen@latitude38.com	ext. 102
Production	Annie Bates-Winship	annie@latitude38.com	ext. 106
Production	Carrie Galbraith	carrie@latitude38.com	ext. 110
Bookkeeping	Penny Clayton	penny@latitude38.com	ext. 101
Other email	general@latitude38.com	Web site: www.latitude38.com	

Latitude 38 Publishing, LLC

15 Locust Avenue, Mill Valley, CA 94941

(415) 383-8200 • Fax: (415) 383-5816

www.latitude38.com

Please address all correspondence by person or department name.

DECEMBER 2016

● indicates full moon.

→ indicates 2-day races. YRA events indicated in bold type.

S	M	T	W	Th	F	S
				1	2	3
4	5	6	7	8	9	10
11	12	13	14	15	16	17
18	19	20	21	22	23	24
25	26	27	28	29	30	31

WEEKDAY & SPECIAL EVENTS

- December:**
- Happy Holidays! Check the Calendar in the Nov. or Dec. issue of *Latitude 38* for lighted boat parades near you.
- December 21:**
- *Winter Solstice*
- December 24:**
- *Hanukkah begins at sundown*
- December 25:**
- *Christmas Day*
- December 31:**
- *New Year's Eve*



FRED FAGO

SATURDAY

Chowder Cup #5, ElkYC – Moss Landing
 Opti Midwinters #1, RYC – Keller Cove
 Winter #2, SeqYC – SB
 Fall Race #4, SSC – Stockton
 Seaweed Soup Midwinter #2, GGYC – City

3

Midwinters #3, BYC – OC

10

Redwood Cup #2, SeqYC – SB
 Island Fever #2, SBYC – SB
 Midwinter #2, SCYC

17

24

31

SUNDAY

Chowder #9, BYC – OC
 Midwinters #6, RYC – SH
 Midwinter #2, SYC – Knox
 Santana 22 Team Racing, SCYC

4

Midwinters #4, BYC – OC
 Midwinter #2, IYC – Estuary

11

Chowder #10, BYC – OC

18

Chowder #11, BYC – OC

25

Marchal Sailmakers

*Specializing in
 Sail Repair and Used Sails*



After hours pick up and drop off available

2021 ALASKA PACKER PLACE, ALAMEDA, CA 94501

Dominic Marchal • (510) 239-5050

www.marchalsailmakers.com

GRAND MARINA FULL SERVICE MARINE CENTER



510.865.1200

2099 Grand Street
 Alameda, CA 94501

grandmarina.com



SAN FRANCISCO BAY

These current charts show direction and speed of the tidal current for each hour of current at the San Francisco Bay entrance. The charts depict the flow of tidal currents under normal weather conditions. Strong winds and freshets, however, bring about non-tidal currents which may modify considerably the speeds and directions shown in the charts.

USE OF CHARTS

The chart to be used for any specific time is determined by obtaining the difference between the desired time and the time of the nearest Maximum Flood or Maximum Ebb for the Golden Gate. The chart with the title that agrees most nearly with this difference is the one to be used.

The numbers before or after the arrows indicate the 'tropic speed' of the current in knots. To determine the actual speed of the current for a particular day and hour, this tropic speed is multiplied by the factor given in the table to the right, 'Factors for Correcting Speeds'. To find the correct 'predicted speed' as listed in the table, see 'Weekend Currents' on pages 79 and 80.

The charts on this page and those that follow are from the National Ocean Service, National Oceanic and Atmospheric Administration of the U.S. Department of Commerce.

FACTORS FOR CORRECTING SPEEDS

MAXIMUM FLOOD			MAXIMUM EBB		
Predicted speed (knots)	Factor		Predicted Speed (knots)	Factor	
0.5-0.8,	multiply by	0.2	0.7-1.1,	multiply by	0.2
0.9-1.1,	multiply by	0.3	1.2-1.5,	multiply by	0.3
1.2-1.4,	multiply by	0.4	1.6-2.0,	multiply by	0.4
1.5-1.8,	multiply by	0.5	2.1-2.4,	multiply by	0.5
1.9-2.1,	multiply by	0.6	2.5-2.9,	multiply by	0.6
2.2-2.4,	multiply by	0.7	3.0-3.3,	multiply by	0.7
2.5-2.8,	multiply by	0.8	3.4-3.8,	multiply by	0.8
2.9-3.1,	multiply by	0.9	3.9-4.2,	multiply by	0.9
3.2-3.4,	multiply by	1.0	4.3-4.7,	multiply by	1.0
3.5-3.7,	multiply by	1.1	4.8-5.1,	multiply by	1.1
3.8-4.1,	multiply by	1.2	5.2-5.6,	multiply by	1.2
4.2-4.4,	multiply by	1.3	5.7-6.0,	multiply by	1.3
4.5-4.7,	multiply by	1.4	6.1-6.5,	multiply by	1.4
4.8-5.1,	multiply by	1.5	6.6-6.9,	multiply by	1.5

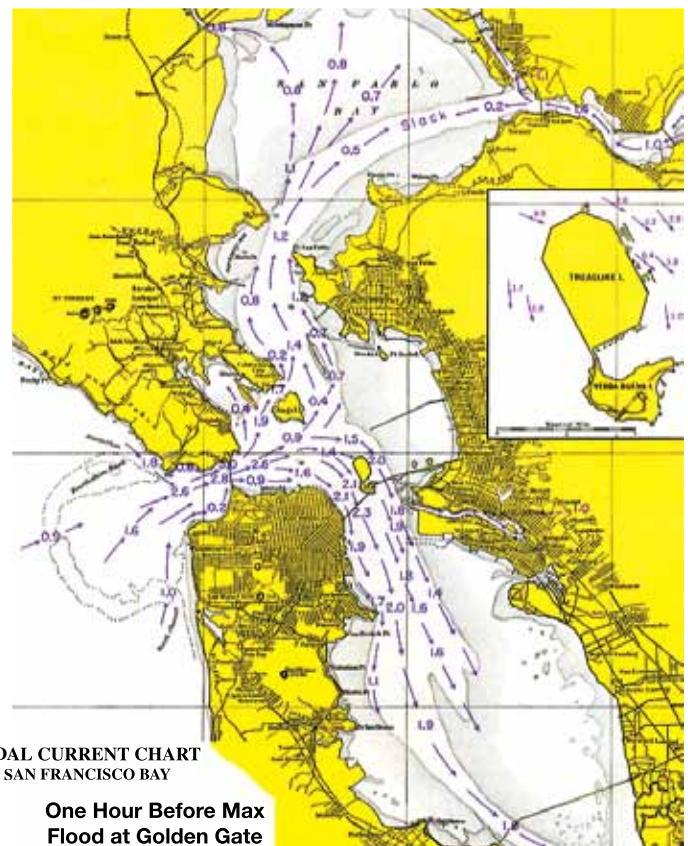
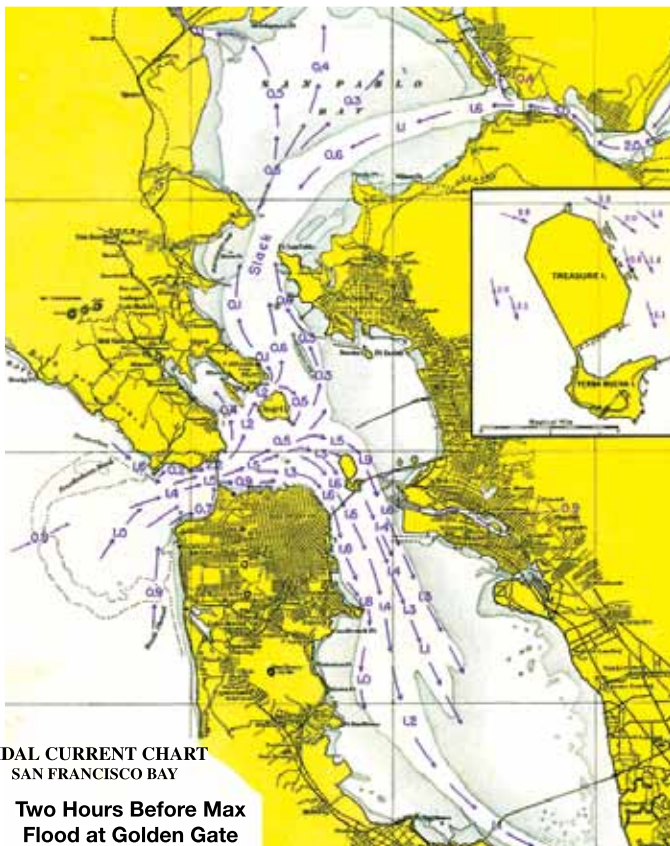

TIDAL CURRENT CHARTS

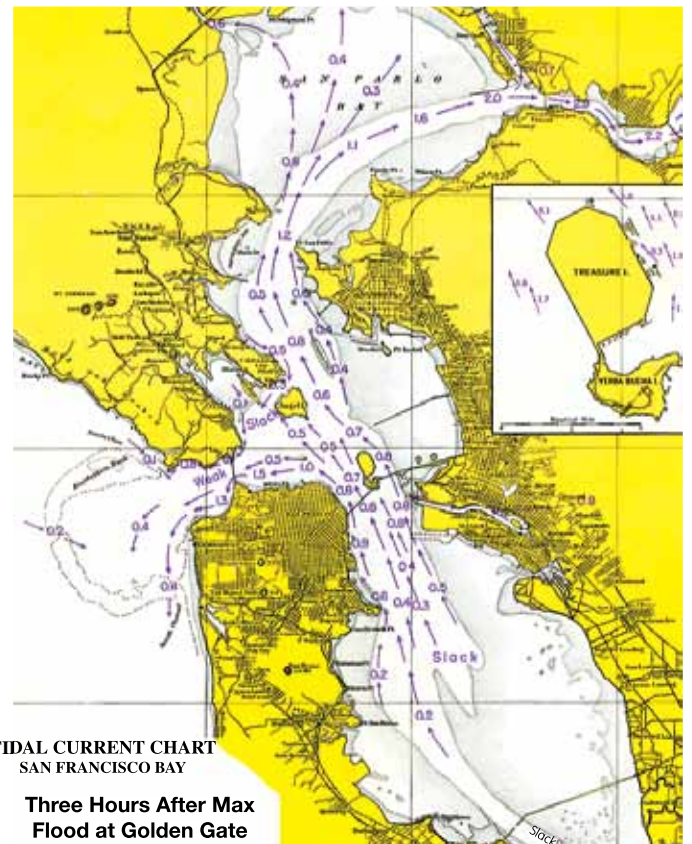
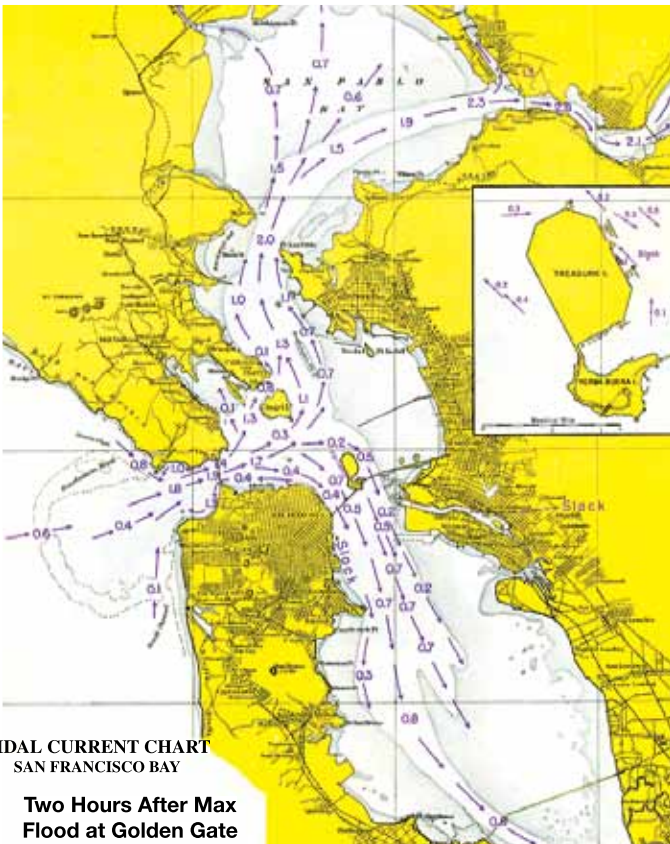
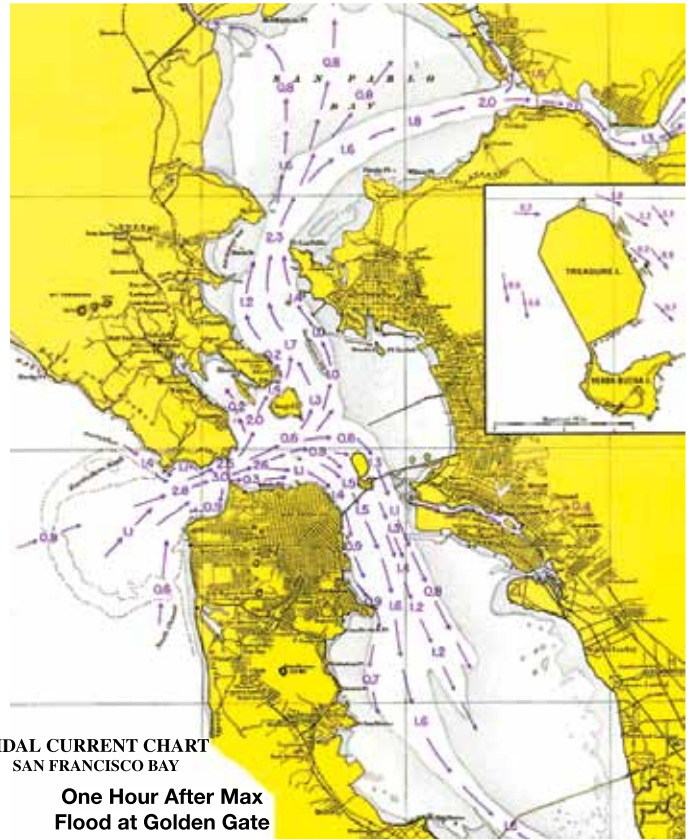
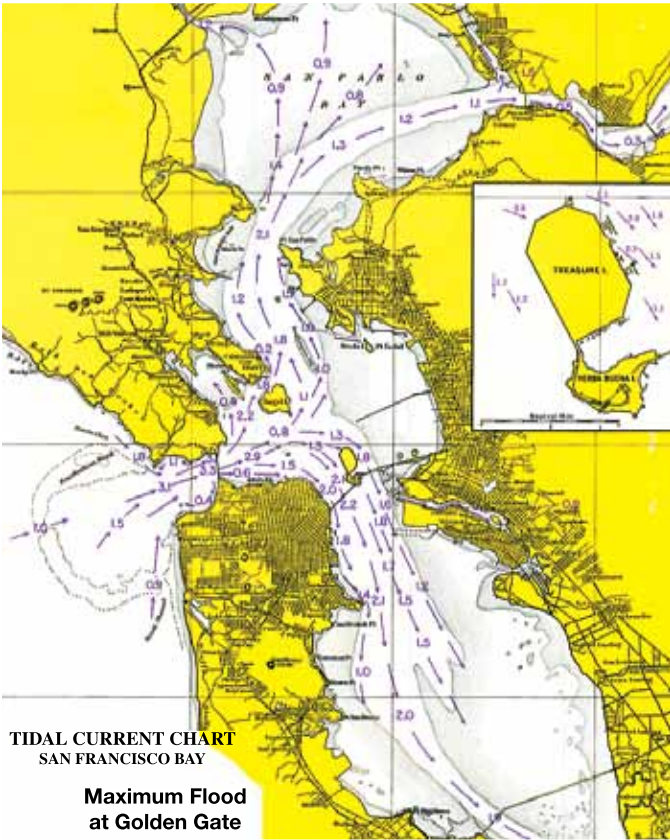

SAN FRANCISCO BAY

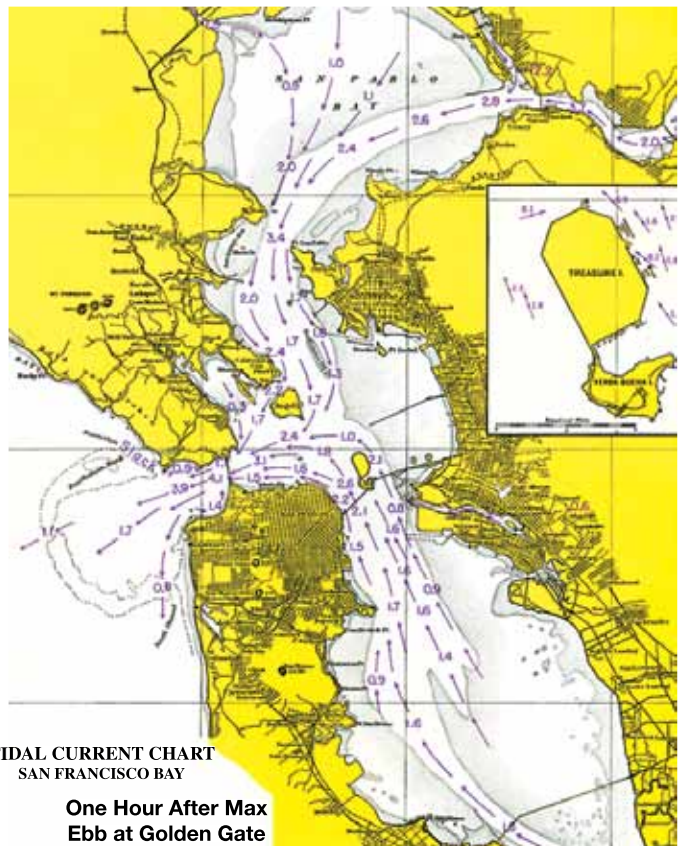
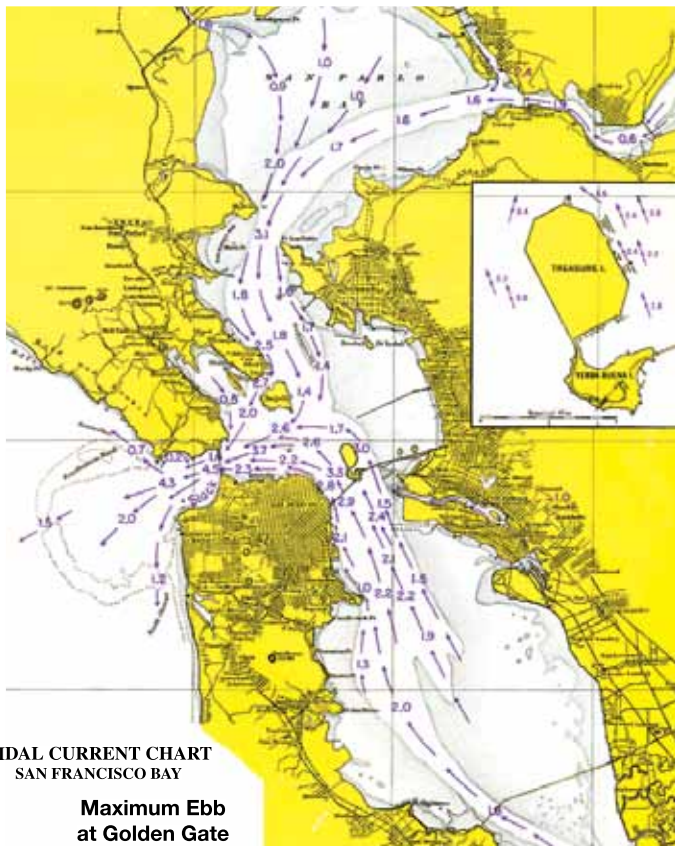
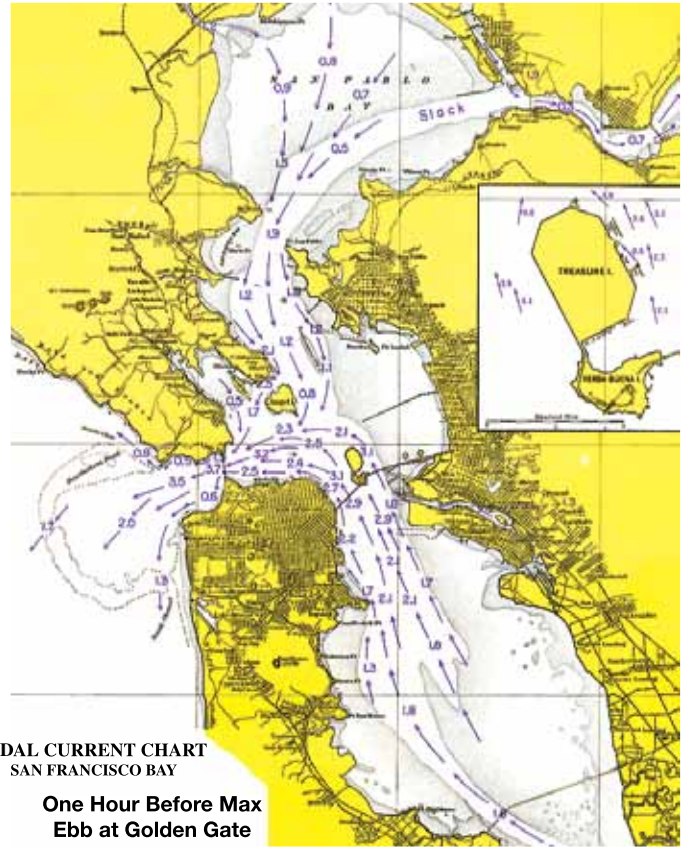
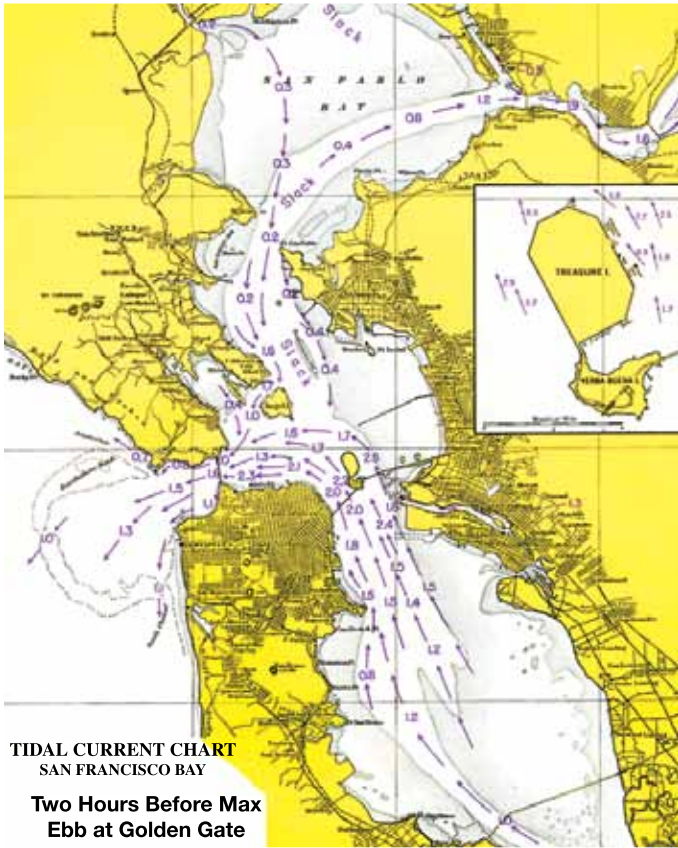

TIDAL CURRENT CHARTS

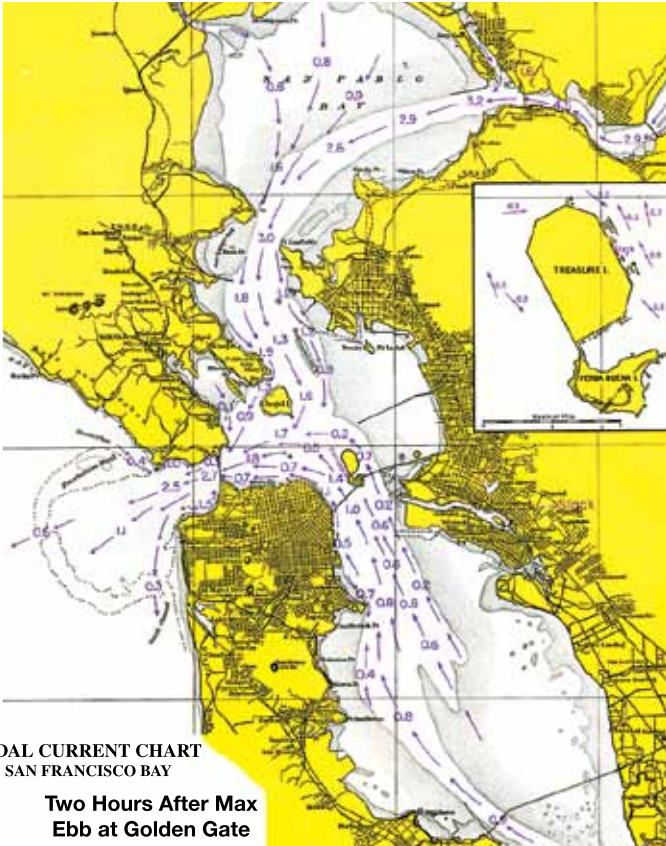

TIDAL CURRENT CHART
SAN FRANCISCO BAY

Two Hours After Max
Ebb at Golden Gate

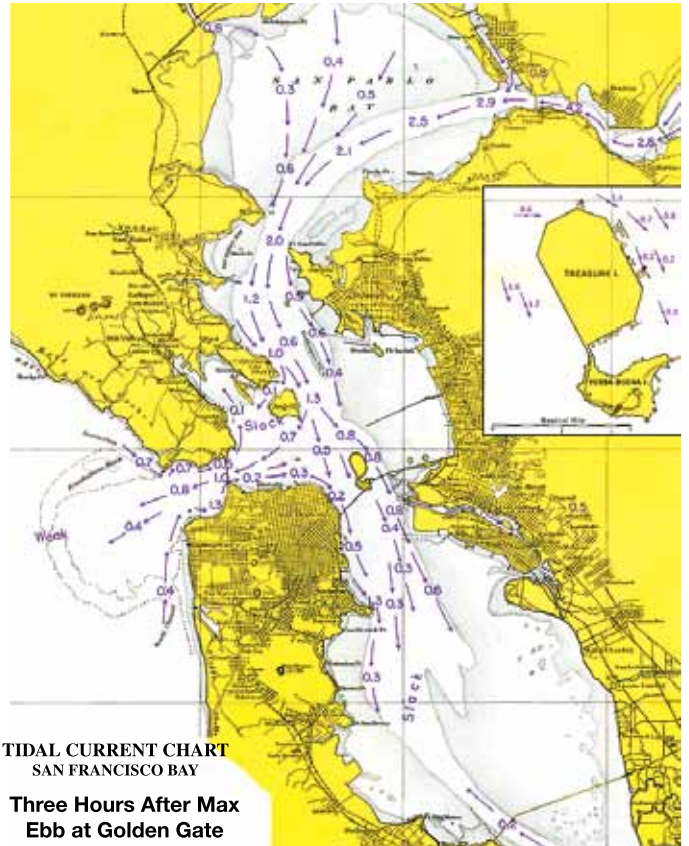

TIDAL CURRENT CHART
SAN FRANCISCO BAY

Three Hours After Max
Ebb at Golden Gate

SF BAY CAL 20 FLEET WE INVITE YOU TO JOIN THE FUN



A Cal 20 renaissance is well underway and our numbers are growing. We're competitive and affordable.

COME OUT AND JOIN US!



415.244.2676
info@sfbaycal20.com
www.sfbaycal20.com

WINDEX INNOVATION

WINDEX[®] 15

with Bird-Proof
Spike!

Why Windex 15 is
the choice for
most sailors:

- 15" wind vane (38 cm)
- Sapphire suspension bearing
- Adjustable tacking arms with tabs
- Vane and tabs feature reflectors for high visibility day and night.
- Weighs just 3.9 ounces (111 grams)
- Stands 12.75" tall (32 cm)
- Bird-proof spike extends another 10" (24 cm) above vane to discourage birds from landing.

The versatile J-Base can be purchased for Windex 15 to allow top or side mounting.



Contact us for your
FREE copy of the latest



catalog

Davis Instruments 3465 Diablo Ave., Hayward, CA 94545 USA
Phone 800-678-3669 • Fax 510-670-0589 • Email info@davisnet.com

www.davisnet.com



deWitt

**Art for
Winners!**

Visit Jim's online store:
www.jimdewitt.com

DeWitt Art Gallery & Framing • (510) 236-1401 • pam@jimdewitt.com

Boomkicker® Boom Supports



- The simple choice for boats 14 to 38 feet.
- Eliminates the need for the topping lift along with the chafe, windage, hang-ups and adjustment.
- Simple flexing design (up or down) is lightweight and fast acting with easy installation separate from the vang, fittings included.
- Proven durable and reliable.

Join Over 10,000 Happy Customers!

www.boomkicker.com
(800) 437-7654 • (708) 482-8801

Manufactured in the U.S. by Seoladair Ltd.

SANTA CRUZ...THE FUN WAY 2016



Get out of the Bay for Labor Day!

**Sail San Francisco to Santa Cruz –
Friday, September 2**

Racing Division
The 70-mile sprint is a great
summer end showdown for all
Type A's!

Cruising Division
The 70-mile rally with comfortable
engine allowance is the laid back
way for all Type B's!
Stay and cruise Monterey Bay

**Racers and cruisers mix it up Saturday and Sunday
with Santa Cruz Yacht Club hosting
Saturday awards ceremony and party**

Registration Includes:

Regatta • All-night Friday chowder service

For race information visit: www.scyc.org/windjammer

2016 WEEKEND CURRENTS

JANUARY – JUNE

NOAA Predictions at the Golden Gate Entrance

JANUARY					FEBRUARY					MARCH				
date/day	slack	max	slack	max	date/day	slack	max	slack	max	date/day	slack	max	slack	max
1/01 Fri	0009	0254/2.1F	0602	0932/2.3E	2/06 Sat		0212/2.2E	0516	0754/2.0F	3/05 Sat		0105/2.1E	0417	0644/1.7F
	1349	1529/0.9F	1745	2118/2.1E		1004	1352/3.8E	1830	2110/2.9F		0851	1249/3.3E	1721	1958/2.6F
1/02 Sat	0054	0337/1.8F	0639	1029/2.3E	2/07 Sun	0015	0254/2.4E	0600	0842/2.3F	3/06 Sun		0145/2.5E	0503	0735/2.1F
	1457	1639/0.9F	1916	2223/1.9E		1053	1437/4.0E	1903	2149/3.1F		0951	1334/3.7E	1755	2036/3.0F
1/03 Sun	0142	0424/1.7F	0715	1124/2.5E	2/13 Sat		0113/3.0F	0341	0700/3.6E	3/12 Sat	0222	0542/4.1E	0947	1241/2.7F
	1554	1755/1.1F	2037	2327/1.8E		1106	1354/2.2F	1621	1939/2.8E		1523	1828/3.0E	2144	
1/09 Sat	0046	0321/2.2E	0617	0901/2.2F	2/14 Sun		0201/2.7F	0423	0752/3.5E	3/13 Sun		0042/2.8F	0402	0727/4.0E
	1106	1453/4.0E	1932	2218/3.0F		1222	1458/1.9F	1741	2045/2.3E		1148	1440/2.4F	1728	2027/2.5E
1/10 Sun	0125	0404/2.3E	0702	0948/2.2F	2/15 Mon		0253/2.3F	0512	0851/3.4E	3/19 Sat		0209/2.7E	0535	0750/2.1F
	1151	1538/4.1E	2006	2258/3.1F		1346	1610/1.8F	1914	2201/2.0E		1035	1419/3.4E	1821	2059/2.8F
1/16 Sat		0235/2.7F	0508	0830/3.2E	2/20 Sat		0215/2.8E	0533	0757/2.5F	3/20 Sun		0257/3.0E	0627	0845/2.4F
	1246	1515/1.7F	1737	2102/2.5E		1038	1420/3.9E	1830	2107/3.1F		1131	1504/3.6E	1900	2135/3.0F
1/17 Sun	0024	0326/2.5F	0556	0928/3.3E	2/21 Sun	0007	0304/3.0E	0624	0849/2.6F	3/26 Sat		0025/2.3F	0248	0620/3.2E
	1407	1628/1.7F	1917	2217/2.2E		1128	1506/3.9E	1909	2145/3.2F		1047	1320/2.1F	1608	1905/2.5E
1/23 Sat	0033	0322/2.8E	0631	0902/2.7F	2/27 Sat		0042/2.2F	0310	0640/2.7E	3/27 Sun		0101/2.1F	0312	0648/3.1E
	1133	1516/4.1E	1935	2212/3.3F		1113	1334/1.5F	1603	1917/2.3E		1130	1408/1.8F	1655	1951/2.1E
1/24 Sun	0119	0411/2.8E	0724	0952/2.6F	2/28 Sun		0120/1.9F	0334	0713/2.6E		2253			
	1222	1604/4.1E	2016	2253/3.2F		1213	1427/1.3F	1700	2009/1.9E					
1/30 Sat		0205/2.0F	0442	0821/2.4E		2310								
	1307	1458/1.0F	1717	2040/2.0E										
1/31 Sun	2355													
	1417	1602/.09F	1844	2142/1.6E										
APRIL					MAY					JUNE				
date/day	slack	max	slack	max	date/day	slack	max	slack	max	date/day	slack	max	slack	max
4/02 Sat		0051/2.0E	0408	0623/1.2F	5/01 Sun		0013/2.2E	0348	0559/1.2F	6/04 Sat		0316/4.7E	0748	1031/3.3F
	0817	1230/2.9E	1659	1938/2.3F		0755	1159/2.8E	1604	1854/2.4F		1337	1617/2.7E	1920	2203/2.9F
	2245				5/07 Sat	0053	0422/4.7E	0843	1132/3.4F	6/05 Sun	0029	0404/4.7E	0837	1121/3.4F
4/03 Sun		0136/2.4E	0503	0724/1.6F		1435	1721/2.9E	2028	2318/3.0F		1430	1712/2.7E	2013	2258/2.8F
	0935	1327/3.2E	1738	2020/2.7F	5/08 Sun	0135	0508/4.6E	0935	1223/3.3F	6/11 Sat	0131	0331/1.4F	0540	0928/2.8E
	2320					1531	1814/2.7E	2119			1336	1615/2.3F	1933	2251/2.4E
4/09 Sat	0206	0531/4.5E	0942	1234/3.2F	5/14 Sat	0308	0459/1.2F	0723	1116/2.6E	6/12 Sun	0247	0434/1.2F	0656	1035/2.4E
	1530	1823/3.0E	2136			1522	1759/2.2F	2112			1428	1705/2.1F	2021	2355/2.5E
4/10 Sun		0028/2.9F	0246	0615/4.4E	5/15 Sun		0031/2.6E	0417	0612/1.3F	6/18 Sat		0259/3.4E	0744	1014/2.4F
	1036	1328/2.9F	1629	1918/2.7E		0852	1228/2.5E	1614	1851/2.2F		1315	1549/2.1E	1848	2127/2.0F
	2226				5/21 Sat	0019	0402/3.6E	0841	1113/2.6F	6/19 Sun		0328/3.6E	0818	1052/2.6F
4/16 Sat		0057/2.5E	0429	0632/1.5F		1415	1656/2.3E	1956	2238/2.1F		1358	1633/2.1E	1928	2209/2.0F
	0913	1304/2.9E	1700	1941/2.4F	5/22 Sun	0046	0432/3.6E	0916	1153/2.6F	6/25 Sat		0202/1.7F	0356	0746/3.5E
	2239					1500	1739/2.2E	2035	2317/2.0F		1148	1458/2.8F	1748	2050/2.5E
4/17 Sun		0149/2.9E	0528	0738/1.8F	5/28 Sat	0053	0320/1.2F	0503	0905/3.0E	6/26 Sun	0023	0300/1.5F	0453	0844/3.2E
	1023	1355/3.0E	1744	2021/2.6F		1320	1624/2.3F	1927	2227/2.2E		1235	1544/2.6F	1828	2140/2.6E
	2320				5/29 Sun	0209	0425/1.1F	0611	1014/2.8E					
4/23 Sat	0130	0509/3.5E	0940	1214/2.4F		1416	1716/2.4F	2014	2324/2.5E					
	1513	1801/2.4E	2106	2348/2.1F	5/30 Mon	0322	0535/1.3F	0739	1128/2.7E					
4/24 Sun	0157	0538/3.5E	1017	1257/2.3F		1511	1809/2.5F	2058						
	1559	1843/2.2E	2144											
4/30 Sat	0239	0449/1.0F	0629	1042/2.7E										
	1513	1803/2.1F	2113											

continued on page 80

Serving the Bay Area Since 1986



THE FASTEST POLISH ON THE BAY!

Be Race Ready Friday With Our Mid-Week Clean & Prep

Fully Insured & Marina Approved
Call now for a Free Estimate

510 428-2522 or 415 457-6300
www.seashine.net



Express 27
THE ULTIMATE SAILING MACHINE

www.express27.org

Fleet Captain:
Zachery Anderson
zachery.anderson@gmail.com

www.facebook.com/express27fleet

from page 79

JULY	date/day	slack	max	slack	max	AUGUST	date/day	slack	max	slack	max	SEPTEMBER	date/day	slack	max	slack	max
	7/02Sat	1236 2325	0213/4.4E 1512/2.5E	0652 1815	0929/3.0F 2100/2.8		8/06Sat	1046 2331	0059/2.3F 1327/2.8F	0330 1628	0656/3.5E 1941/2.9E		9/03Sat	0235 1505	0553/3.5E 1822/3.2E	0935 2215	1211/2.9F 0634/3.2E
7/03Sun	1327 0016	0303/4.5E 1607/2.6E	0740 1910	1020/3.3F 2152/2.8F	8/07Sun	1121	0150/1.9F 1406/2.5F	0418 1657	0741/3.1E 2020/2.7E	9/04Sun	1008 2303	0040/2.4F 1247/2.6F	0322 1531	0634/3.2E 1853/3.1E			
7/04Mon	1416	0355/4.5E 1701/2.7E	0827 2005	1108/3.4F 2243/2.8F	8/13Sat	1100 2102	0044/2.5E 1333/1.7E	0538 1634	0809/1.7F 1858/1.3F	9/05Mon	1041 2354	0128/2.1F 1324/2.3F	0410 1553	0717/2.8E 1923/2.9E			
7/09Sat	1202 0105	0211/1.8F 1448/2.6F	0428 1755	0805/3.2E 2111/2.6E	8/14Sun	1145 2157	0127/2.8E 1418/1.9E	0615 1725	0845/2.0F 1950/1.5F	9/10Sat	0406 1512	0627/1.3F 1725/0.9F	0931 1908	1210/1.5E 2341/2.3E			
7/10Sun	1245	0308/1.4F 1530/2.2F	0522 1834	0859/2.7E 2202/2.4E	8/20Sat	1504	0538/4.0E 1808/3.4E	0926 2145	1223/3.3F 0625/3.8E	9/11Sun	0454 1618	0724/1.6F 1829/1.1F	1026 2021	1306/1.7E 1109/3.3F			
7/16Sat	1212 2229	0200/3.1E 0441/1.9E	0645 1743	0915/2.1F 2015/1.7F	8/21Sun	1004 2235	0036/2.6F 1303/3.2F	0257 1536	0625/3.8E 1847/3.6E	9/17Sat	0112 1344	0435/3.8E 1655/3.8E	0816 2041	1109/3.3F 2333/2.9F			
7/17Sun	1253 2310	0228/3.3E 1525/2.1E	0719 1826	0950/2.4F 2100/1.9F	8/27Sat	1601	0707/2.2F 1832/2.0F	1012 2058	1258/2.1E 0809/2.6F	9/18Sun	0205 1417	0522/3.7E 1734/4.0E	0854 2128	1149/3.3F 1131/2.0E			
7/23Sat	1035 2256	0052/2.2F 1338/3.1F	0259 1624	0639/3.9E 1924/2.9E	8/28Sun	1110 2211	0059/3.5E 1357/2.5E	0532 1709	0809/2.6F 1936/2.2F	9/24Sat	0257 1442	0528/2.0F 1705/1.7F	0843 1920	1131/2.0E 2320/3.0E			
7/24Sun	1114 2354	0144/2.1F 1420/3.0F	0352 1658	0730/3.6E 2008/3.1E	9/25Sun	1601	0643/2.2F 1817/1.7F	0948 2048	1244/2.3E	12/03Sat	0939 2224	0045/2.5F 1212/1.5F	0356 1403	0636/2.0E 1754/3.4E			
7/30Sat	1129 2218	0107/3.8E 1408/2.3E	0550 1710	0824/2.6F 1950/2.4F	11/05Sat	1157	1426/1.1F 0251/1.9F	1607 0605	2004/2.9E 0852/1.7E	12/04Sun	1031 2304	0128/2.4F 1302/1.3F	0435 1448	0722/2.0E 1843/3.2E			
7/31Sun	1221 2317	0205/4.1E 1502/2.6E	0640 1810	0917/3.0F 2045/2.6F	11/06Sun	1205	1422/0.9F 0121/3.0E	1556 0446	2005/2.7E 0739/3.0F	12/10Sat	0849 2218	0009/2.5E 1222/3.8E	0321 1649	0619/2.6F 1921/2.4F			
10/01Sat	1344	0449/3.3E 1711/3.5E	0823 2109	1058/2.8F 2336/2.7F	11/12Sat	1012 2319	1333/4.1E 0211/3.0E	1747 0528	2027/2.8F 0822/3.0F	12/11Sun	0932 2318	0104/2.6E 1305/4.3E	0412 1737	0707/2.8F 2015/2.9F			
10/02Sun	1409	0530/3.1E 1740/3.4E	0857 2152	1133/2.6F	11/13Sun	1047	1412/4.5E 0136/2.8F	1832 0448	2118/3.2F 0739/2.4E	12/17Sat	0938 2224	0022/3.2F 1209/2.3F	0335 1425	0624/2.7E 1804/3.9E			
10/08Sat	1332	0431/1.4F 1550/0.9F	0748 1725	1028/1.5E 2137/2.4E	11/19Sat	1051 2345	1322/2.0F 0230/2.6F	1529 0544	1913/3.5E 0842/2.4E	12/18Sun	1042 2312	0111/3.0F 1306/2.0F	0422 1520	0719/2.6E 1900/3.5E			
10/09Sun	1450	0531/1.5F 1653/0.8F	0850 1827	1134/1.6E 2251/2.4E	11/20Sun	1209	1423/1.6F 0607/2.3F	1630 0910	2020/3.1E 1246/3.2E	12/24Sat	0854 2228	0018/2.1E 1257/3.1E	0333 1713	0605/1.9F 1942/2.0F			
10/10Mon	1559	0628/1.8F 1801/1.0F	0942 1947	1233/1.9E	11/24Th	1643	1900/1.9F 0047/2.6E	2145 0415	0649/2.3F 1952/2.2F	12/25Sun	0927 2319	0107/2.1E 1329/3.3E	0419 1755	0649/1.9F 2026/2.3F			
10/15Sat	1228	0329/3.5E 1543/4.0E	0703 1942	0955/3.2F 2230/3.0F	11/25Fri	0946 2242	1326/3.4E 0132/2.6E	1730 0456	1952/2.2F 0727/2.3F	12/26Mon	0957 0243	0153/2.1E 1356/3.4E	0501 1833	0731/1.9F 2105/2.5F			
10/16Sun	1301	0418/3.4E 1622/4.3E	0742 2028	1036/3.2F 2320/3.2F	11/26Sat	1016 2332	1359/3.5E 0216/2.5E	1812 0533	2039/2.5F 0805/2.3F	12/31Sat	1303	0523/2.2E 1654/3.8E	0829 2115	1105/1.9F			
10/22Sat	1314	0356/2.3F 1540/1.7F	0711 1744	1000/2.1E 2136/3.1E	11/27Sun	1042	1428/3.6E	1852	2122/2.6F								
10/23Sun	1440	0500/2.2F 1648/1.5F	0817 1904	1114/2.2E 2302/2.8E													
10/29Sat	1230	0341/3.0E 1603/3.6E	0710 2009	0943/2.6F 2236/2.7F													
10/30Sun	1253	0425/2.8E 1632/3.6E	0745 2050	1020/2.5F 2320/2.7F													



Master Mariners 23rd Wooden Boat Show • Sunday, June 26

10 am to 4 pm ~ Corinthian Yacht Club

View and board classic sailing vessels, meet their skippers and learn the yachts' unique history. Show proceeds to go Master Mariners Benevolent 501(c)3 Foundation. The Foundation provides scholarships for youth sailing, wooden boat building and maritime education. Also provides for the preservation of SF Bay Classic yachts. MMBF is dedicated to preserving the continuity of traditional yachting on San Francisco Bay. Outdoor bar and grill is open for lunch. Model boat building for kids. Children under 12 free when accompanied by an adult.

Our Annual Regatta – Saturday, May 28

Master Mariners Benevolent Association

www.mastermariners.org

COMBINING A LOVE FOR WINE *with*
A PASSION *for* SAILING.



Dry Creek
VINEYARD

THE OFFICIAL
SINCE  1972

WINE FOR
SAILORS™

“The good folks at Dry Creek are committed to our sport and to making great wine.”

– Peter Isler, two-time America’s Cup winner

POST OFFICE BOX T · 3770 LAMBERT BRIDGE RD · HEALDSBURG, CA 95448 · 707-433-1000 · drycreekvineyard.com · © 2013 Dry Creek Vineyard, Healdsburg, CA



San Francisco to Monterey

The San Francisco Yacht Club and
Monterey Peninsula Yacht Club

invite you to spend
your Memorial Day
Weekend racing in
the 19th Annual
Spinnaker Cup



Start on Friday, May 27, in the Knox Race Area.
Finish off Municipal Wharf #2 in Monterey.

The Notice of Race
will be available at: www.sfyc.org and www.mpyc.org

For further information please contact:
Race Office, SFYC 415.789.5647 race@sfyc.org
Rear Commodore, MPYC 831.372.9686 race@mpyc.org



ORGANIZED 1896

Pacific INTER CLUB *Yacht Association*

~ ANNOUNCEMENT OF 2016 REGATTAS ~

LIPTON CUP SERIES

Hosted by Sausalito Yacht Club • Saturday, July 9

Big Lipton	J/105 Class
Larry Knight Perpetual Challenge	Express 27 Class
Little Lipton	SF 30 Class
Admiral's Perpetual Trophy	Cal 20 Class

YOUTH REGATTA

Hosted by SeqYC, PYSF and BAYS • July 24-25

Optimist	Division A	10 & under
Optimist	Division B	12 & under
El Toro	Division C	16 & under
CFJ	Division D	Grades 8-12

Two boats per division per yacht club.

CHISPA

Hosted by Encinal Yacht Club • Saturday, June 18

Laser	PICYA Small Boat Perpetual Trophy	All ages
-------	-----------------------------------	----------

One boat per yacht club

Go to www.picya.org for Regatta News

Reliable Marine Electronics

SALES | SERVICE | INSTALLATION

(510) 864-7141

B&G

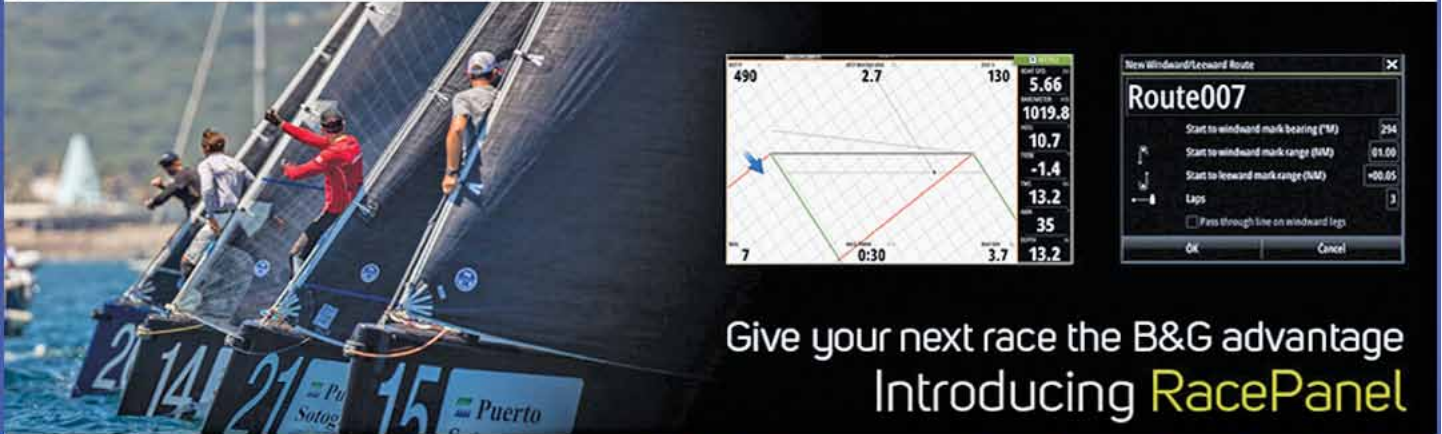

Give your next race the B&G advantage
Introducing **RacePanel**

www.ReliableMarine.com

1925 Lafayette St Alameda, CA 94501

ALPHA INDEX

Alphabet Soup	14
Beer Can Series	22-25
Caribbean Circuit	26
Contacts	
Associations	14
<i>Latitude 38</i>	72
PHRF Committee	16
YRA	8
Yacht Clubs	12
Contents	4
Equipment List	20
Flags	50
Fleet Schedules	32-33
PHRF Instructions and Info	40-49
Marks and Racing Areas	34-39
Midwinter Series	28-29
Monthly Calendars	51-73
Pacific Ocean Events	70
Racing Rules	18
Season Winners 2015	10
Shorthanded Races	30
Sunrise/Sunset Times	72
Tidal Current Charts	74-77
Tidal Current Predictions	
January-June Weekends	79
July-December Weekends	80
VHF Radio Channel Uses	64
Welcome Letter	6
Women's Circuit	68
YRA Races	41-47
Youth Sailing	52-60

ADVERTISER INDEX

Alpha Marine Systems	31
Alpha Ropes	21
Bainbridge	29
Bay Area Multihull Association	54
Bay Marine Boatworks	9
Bay Risk Insurance	21
Bay View Boat Club	63
Berkeley Yacht Club	37, 62, 66
Boome, Chris, Insurance	51
Boomkicker	78
Butler Rigging	71
CA Offshore Series/Coastal Cup	55
Cal 20 Fleet	77
Colligo Marine	23
Corinthian Yacht Club	12
Davis Instruments	77
Defender Industries	22
DeWitt Studio	78
Dimension Polyant	32
Doyle Sails	5
Dry Creek Vineyards	81
Dubarry	50
Easom Racing & Rigging	2-3
El Toro Association	62
Encinal Sailing Foundation	11
Express 27 Fleet	79
Express 37 Fleet	66
Golden Gate Yacht Club	30

Grand Marina	73
Hansen Rigging	25
Harken	4
Hogin Sails	56
Island Yacht Club	6
Islander 36 Association	66
J/105 Fleet #1	19
J/120 Fleet #5	17
Key West Race Week	64
KKMI Boatyard	84
<i>Latitude 38</i> Crew Party	28
Marchal Sailmakers	73
Marina Bay Yacht Harbor	62
Mariners General Insurance	23
Master Mariners Benevolent Association	80
Modern Sailing School & Club	54
Musto	50
Oakland Yacht Club	8
Outboard Motor Shop	37
PICYA	81
Pacific Cup Yacht Club	70
Pettit Paint	7
Pineapple Sails	50, 52
Pirate's Lair	14
Quantum Pacific	61
Reliable Marine Electronics	82
Richmond Yacht Club	83
Robichaud Batten System, Inc.	72

Rogue Rigging	53
Sail California	18
Santana 22 Fleet	66
Sausalito Yacht Club	38
Schaefer Marine	26
Seashine	79
Sequoia Yacht Club	31
Singlehanded Sailing Society	69
South Beach Yacht Club	65
Spinlock	50
Spinnaker Cup / MPYC	81
Stockton Sailing Club	59
Strictly Sail Pacific	15
Sunsail Charters	27
Team McLube	33
Trident Funding	67
Twin Rivers Marine Insurance	16
Tylaska	58
UK Sailmakers	42
Ullman Sails San Francisco & Monterey Bay	23
Vallejo Marina	60
Vallejo Yacht Club	57
Waterat	26
Westwind Precision Details	72
Wichard Sparcraft, Inc.	13
Whiskeytown Sailing Club	28
Windjammer Yacht Club	78



Greg Gorsiski, Artist

Join the fun!

RICHMOND YACHT CLUB

REGATTAS

- BIG DADDY . *April*
- GREAT PUMPKIN *October*
- DELTA DITCH RUN *June*
- BIG DINGHY . *April*
- EL TORO STAMPEDE *October*
- MULTIHULL REGATTA *September*
- SMALL BOAT MIDWINTERS *Jan, Feb, Mar & Dec*
- LITTLE DADDY . *April*
- TOTALLY DINGHY *September*
- WOMEN'S 420 *Jan & Feb*
- MEN'S 420 *Jan & Feb*
- LASER MASTERS . *August*
- SPORT BOAT INVITATIONAL *October*
- BEER CAN RACING . *April - Sept*
- Junior Program . *All year long*



richmondyc.org

510.237.2821

EMAIL rycharbor@richmondyc.org



MORE SPEED – DELIVERED

HOME

SERVICES

LOCATIONS

STORE

YACHT SALES

GENERAL YARD

HAULS & LOADING

BOTTOM PAINTING
& REPAIR

FINISH PAINTING
& DETAILING

GEL COAT
& FIBERGLASS

WELDING
& FABRICATION

WOODWORKING
& CABINETRY

SYSTEMS & EQUIPMENT

RIGGING

ENGINES

ELECTRONICS

RACING SERVICES



If you are looking for ways to get a little more speed out of your boat, come visit us at KKMI. From the masthead to the keel, our marine professionals can look at your boat with a fresh eye and suggest ways to sail faster without "crashing" the budget.

KKMI is skilled in:

- ▶ Super-Slippery Bottom Jobs
- ▶ Foil Optimization
- ▶ Rig Inspections
- ▶ Life Line Replacement
- ▶ Engine Service*

** Be first at the finish line and the club house!*



PT. RICHMOND (510) 235-5564

SAUSALITO (415) 332-5564

WWW.KKMI.COM