

BOAT SHOW GUIDE

Strictly Sail Pacific

April 9-12, 2015

Jack London Square • Oakland, CA

THE WEST COAST'S ONLY

All-Sail

BOAT SHOW!

Visit StrictlySailPacific.com
for tickets and show details



Find us on:
facebook



#SSPAC15

INSIDE:

- Seminars
- New Products
- Boat Showcase
- Show Highlights



PETTIT



HYDROCOAT^{eco}

COPPER-FREE ABLATIVE ANTIFOULING

- *The first copper-free, water-based ablative*
- *Dual biocides for multi-season protection*
- *Ablative technology eliminates sanding or paint build-up*
- *Easy cleanup with soap and water*



pettitpaint.com • 800-221-4466

AIR AND SEA WILL NEVER KNOW.

All you sceptics who believe you can't get real fouling protection without heavy loads of copper and solvent, meet the mind changer. Hydrocoat ECO. Water-based Hydrocoat ECO is a new clean world of solvent-free antifouling. It contains the breakthrough additive Econeal that reduces copper by 100% yet delivers 100% of the copper effectiveness. It's all about maximum protection with minimum impact. It's a clean new day.

HYDROCOAT^{eco}
Copper-Free Ablative Antifouling

Catalina // Yachts

5 SERIES

Introducing Catalina's New
Generation of Award-Winning
Design Innovation



The new *5 Series* models elevate the Catalina line to a new level of performance, refinement and finish – truly raising the bar for production boat building. The *5 Series* was designed and built with features sailors appreciate and the strength and systems required to realize cruising aspirations.

Details are important, and the *5 Series* is distinguished by all the right elements and materials critical to your safety and long term ownership satisfaction. Notable construction features are a watertight collision bulkhead and StrikeZone™ impact-absorbing chamber forward; DeepDefense™ rudder system for failsafe steering; SecureSocket™ mast support chainplate system for perfect load resolution and watertight integrity; cast lead (not iron) keels for superior stability and safety. Teak wood detailed interiors make the *5 Series* yachts as pretty as they are strong.

Ask your dealer about the
unique advantages of the
Catalina 5 Series

445

CE Category A
NMMA
ABYC

Farallone Yachts

Alameda, CA • 510-523-6730
www.faralloneyachts.com

The Closer You Look, the Better it Gets!

CatalinaYachts.com

See Us at
Strictly Sail Pacific
Jack London Square
April 9-12, 2015

Strictly Sail Pacific

April 9-12, 2015

Jack London Square • Oakland, CA

The Largest All-Sail Boat Show on the West Coast

When it comes to sailing, Strictly Sail Pacific is the place to be for the best selection of boats, the latest products, the coolest gear, and FUN activities for the entire family. There is so much to do and see, so be sure to plan your time to take full advantage of all the exciting opportunities, including hundreds of free seminars, on-the-water activities, parties, live music, and much more.



PURCHASE TICKETS ONLINE
at www.strictlysailpacific.com

Thank you to our Sponsors





Hylas 63 – Elegant at Anchor, Strong and Fast Offshore



The new Hylas 63 is the ultimate performance cruiser for couples. Born from our customers' desire for a 60-footer to take them anywhere, we reached out once again to Germán Frers for his impeccable yacht design philosophies. The 63's nearly plumb bow, powerful stern sections, and modern rig deliver the swiftness, power, stability, and sea kindliness the design brief mandated. Her Twaron aramid reinforced hull yields bullet-proof strength for the ultimate in safety offshore which Hylas demands.

While her hull shape and construction

create fast, safe passages, below deck space is maximized for comfort. With room to express personal tastes in interior design and function, each Hylas 63 has evolved from one to the other with no two alike in materials, shapes, or equipment. This flexibility is corralled only by imagination as our team of talented craftsmen is more than up to the challenge.

We invite your closer inspection of the Hylas 63 and all our Hylas yachts. You'll find that no other yachts compete. On the water. On the drawing board. For life.



 **SELDÉN**
for sailing

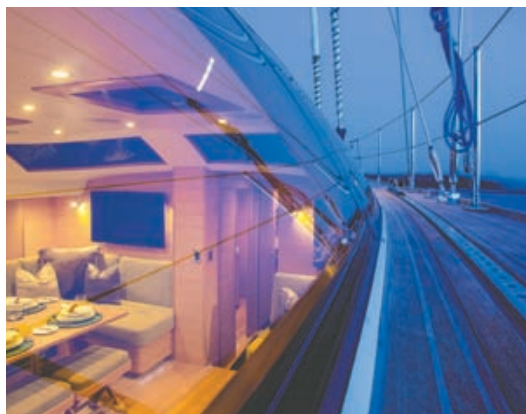

Hylas

46 • 49 • 56 • 63 • 70

Hylas Yachts, 2 Market Square
Marblehead, MA 01945

1-800-875-5114

www.hylasyachtsusa.com

email: hylas@hylasyachtsusa.com

Built by Queen Long Marine Co. Ltd.

Strictly Sail Pacific

April 9-12

Jack London Square • Oakland, CA

LOCATION

On San Francisco Bay at Jack London Square in Oakland, California, just across the Bay from downtown San Francisco, with easy access from around the Bay Area by ferry, BART, train or bus. See pages 50-54 for accommodations, transportation, directions and parking details. The only pets we can allow are guide dogs or other licensed working dogs.

SHOW HOURS

Thursday, April 9: 10 a.m. – 6 p.m.
Friday, April 10: 10 a.m. – 6 p.m.
Saturday, April 11: 10 a.m. – 7 p.m.
Sunday, April 12: 10 a.m. – 5 p.m.

ADMISSION

Thrifty Thursday Adult Ticket*	\$11
One-Day Adult Ticket	\$15
Two-Day Adult Ticket (online only)	\$25
Four-Day Pass (online only)	\$45
Children 12 and younger (must be accompanied by a paying adult)	Free

* Available online only through March 25



 Join us on Facebook at www.facebook.com/StrictlySailPacific

 Follow us on Twitter at www.twitter.com/StrictlySailPac

CONTENTS

Show Sponsors.....	5
Ticket Information/Show Hours.....	8
Association Manager's Welcome	10
New Boat Showcase	12-18
Cool Products	20-27
Show Highlights.....	28-33
Advance Registration Seminars	34-37
Free Seminars	38-43
Let's Party.....	44
Exhibitor List	46-49
Accommodations/Travel/Dining	50-52
Local Contacts	50
Show Directions/Parking	53
Advertisers' Index.....	55

SKIP THE LINES – PURCHASE TICKETS ONLINE

Save time and money by purchasing your tickets online at www.strictlysailpacific.com.

Enter Promotional Code "SHOWGUIDE" and save \$2 on the ticket price.



IMPORTANT SHOW UPDATES: All information in this directory is accurate at the time of printing. Sail America may, however, make changes and substitutions to the show layout, event programming, seminars and exhibitor listing, etc. Please visit www.strictlysailpacific.com for the latest show news and updates.

OCEANIS

31

[35]

38

41

45

48

55

60

FIRST

20

22

25

30

35

SENSE

43

46

50

55



[YOUR BOAT. YOUR RULES. ACT TWO.] Oceanis³⁵

The era of custom sailing for every sailor has become even more attainable with the **Oceanis 35**. Beneteau shook the sailing world last year with the introduction of the Oceanis 38, a yacht that could be either a daysailer, weekender or cruiser. The 35 is the next logical step in this evolution of adaptability. She features all the elegant design elements and flexibility of her big sister with even more value.

Tour the Oceanis 35 at Strictly Sail Pacific, April 9 - 12. Visit Oceanis35.com to learn more. Inquiries: 410-990-0270 or sail@beneteau.com



BENETEAU

Welcome to the 2015 Strictly Sail Pacific Boat Show – a Four-Day Sailing Extravaganza!

On behalf of the Strictly Sail Pacific Show Team, the Sail America Board of Directors, Sail America Members and our many exhibitors, welcome to the 2015 Strictly Sail Pacific Boat Show – the largest all-sail boat show in the Western United States!

This year, we have filled the basin with all that is new and exciting in the world of sailing. See the latest daysailers, cruising and racing sailboats making their U.S. and West Coast Premieres.

Check out the exhibit hall with two floors filled with everything that is hot in the world of sailing gear, hardware and accessories, and speak with product experts with the knowledge to improve your sailing experience.

With four days of FREE seminars, Strictly Sail Pacific is the place to learn from the experts on a host of topics from cool new products that nobody knows about and long-distance family cruising, to weather and communications. And don't forget to stop by the Author's Corner to find the latest nautical books and meet the sailors that have 'been there and done that.'

Seminars – did we mention seminars? We've assembled some of the best speakers to help you extend your learning to the next level. Sign up for the US Sailing Coastal Safety at Sea seminar, moderated by Chuck Hawley, that meets new training requirements for sailors racing in San Francisco offshore races. Check out our other seminars, led by industry pros like Pam Wall, Lee Chesneau and Lin Pardey.

This year's Discover Sailing is bigger and better than ever. If you're new to sailing, sign up for a Taste of Sailing and experience the fun and joy of sailing on San Francisco Bay. Want to improve your anchoring or docking skills, sail a catamaran before you take a charter, or try your hands at match racing? Then sign up for one of our many hands-on on-the-water learning classes!

Are you ready to party? Friday night kicks into high gear with the popular TGIF exhibitor parties, including *Latitude 38's* annual Baja Ha-Ha, Pacific Puddle Jump, and West Coast Circumnavigators' Reunion. On Saturday night, join Bob Bitchin and celebrate the cruising lifestyle at the legendary *Cruising Outpost Cruisers' Bash*, featuring live music by Eric Stone.

One thing is for certain...if you're into sailing or have any interest in the sailing lifestyle, this is THE place to be on April 9-12. Come with friends or bring the family! I hope to see YOU there.

Good Sailing,



Peter Durant
Association Manager, Sail America



PETER DURANT

Official Show Guide



Produced by



20th Strictly Sail Pacific Boat Show

Association Manager

Peter Durant

Sales Manager

Sara Watson

Operations Manager

Jorgen Bateman

Show Office Support

Stephanie Grove

Seminar Coordinator

Kate Stanley

Discover Sailing Coordinator

Gary Edelman

Finance Manager

Kayce Florio

Show Guide Published by

Latitude 38



Stop by
and see the
latest J/Boats!



Come to Strictly Sail Pacific and step aboard the new J/111, J/88 and J/70

J.
111

A Fast 36-ft One Design
with a Comfy Cockpit
and Speed to Burn

J.
88

The 29-ft Family Speed-
ster with Stability, Style
and Sailing Comfort

J.
70

The Hot, New
NextGen Family
Trailer Sailor

J/111s are gracing harbors everywhere as sailors discover the latest in ease, comfort and efficiency from J/Boats. The J/111 is a sleek, speedy, one design 36-footer that is the ultimate daysailing, racing and weekend cruising sailboat. Now on SF Bay a one-design class including Rolex Big Boat Series.

The J/88 hits the sweet spot in J/Boats' performance sprit range – large enough to provide the creature comforts of a sit-in cockpit, inboard diesel, overnighting interior and head; and small enough to be single-point lifted, and owner trailered and stored. The order backlog is building, so come have a look and order your J/88 today.

The J/70 Speedster (22.75 feet) is J/Boats' first ramp-launchable keelboat, designed to fulfill the growing need for an easy-to-own, high performance one design that is exciting to sail, stable enough for the family, and built to last. With fleets established around the world, the J/70 is on track to take the world by storm.

*Come by the show to see the newest in the J/Boat line-up.
We'll then make arrangements for the best part of any J/Boat –
the not-to-be missed test sail.*

Call San Francisco (510) 523-8500 • www.sailcal.com

New Boat Showcase

DEHLER 46 – Premiere

Making her first appearance and nominated for European Yacht of the Year 2015, the Dehler 46 is the new big sister to the multi-award-winning 38, and was launched in Germany in August 2014.

The goal with this model was to build the best performance cruiser in its class – and we think they have aced it!



The head-turning lines are a result of precise hydrodynamic research done by Judel/Vrolijk and Co., comprehensive input from the interior design team, and carefully analyzed human behavior and motion studies.

The 46 offers vacuum infusion, advanced materials, a carbon grid system, composite bulkheads, sufficient tankage, smart interior solutions and so much more.

ASA FIRST 22 – Premiere

Beneteau and ASA have co-developed a new sail training vessel using Beneteau's popular First 20 as its inspiration.

Some of its features include an extended cockpit to give students and instructors more room, a rig designed specifically for sail training, and ergonomic and safety innovations to ensure that every sail is comfortable and safe.



PHOTO BILLY BLACK

The research and development team at Beneteau used input from ASA instructors, schools, and leading competitive sailors to refine and adapt the design of its very successful First 20.

This collaboration has produced a singularly modern sail-training vessel to make learning how to sail easier, safer and more fun!

OCEANIS 35 – Premiere

The Oceanis 35s are as unique as their owners, but still have the soul of a Beneteau at their core. With a long list of options, each can be customized as the daysailer, weekender, or the full-on cruiser of your dreams. You create a yacht as simple or as luxurious as you want – from couples looking for simplicity to families needing a full range of conveniences. It's your boat. And your boat should fit you, not the other way around.



Catalina 275 Sport

The new Catalina 275 Sport just may be the boat you've been waiting for.

Maybe you want to recapture the pure joy of sailing in a simpler but stylish boat that doesn't require much effort or crew to get you out on the water...

Maybe you no longer need the amenities or complications of a larger boat just to enjoy an afternoon out on the water with a few friends...

Maybe a pretty and fast boat will just be more fun to own! Head down to the Catalina Yachts display to see the 275 Sport and more from Catalina.





VISIT US AT **BOOTH 60/61** FOR
GEAR PACKAGES

zhik®

AND
SHOW SPECIALS



ELITE
O F F S H O R E

DON'T COMPROMISE,
Experience the world's best
kit in your in bag by taking
advantage of the savings on
select Henri Lloyd kits.
We'll even throw in the
bag for free.

VISIT US AT **BOOTH 70/71**



HENRI LLOYD

New Boat Showcase

SENSE 50

The monohull with cat-like reflexes.

When Beneteau introduced the world to Sense, it delivered a ground-breaking new yacht that combined catamaran-like livability and cruising comfort in a monohull. Her salon is more like a spacious living room, filled with natural light.



PHOTO GILLES MARTIN-RAGET

Topside, her expansive cockpit makes entertaining effortless, and her balanced sail plan and main sail arch help make sailing a joy. Her hull features a generous beam and a hard chine for flatter and faster sailing. Beneteau's no-compromise build quality and millions of trouble-free cruising miles make Sense the choice for those who love the water and love sailing across it.

C&C 30 – Premiere

The C&C 30 one-design high performance race boat offers the thrill and technology of big-boat grand prix sailing in a size that's fun, easy to sail and affordable. No other contemporary offshore-capable race boat in this size range offers such proven grand prix features, sleek styling cues, and ease of sailing at such a great value.



The C&C 30 combines a stiff, slippery-fast hull, a powerful sail plan, ultra high-tech construction and materials, with an uber-efficient deck layout. Plus, the boat is a featherweight flyer that's tough enough to stand up to the rigors of middle-distance offshore racing too. The fun is just beginning.

LAGOON 450 – Premiere

Replacing a catamaran that has come to be seen as a benchmark is no easy task. But the VPLP architects, in partnership with Lagoon and the celebrated Nautica Design studio, have been brilliantly successful in creating the new Lagoon 450.



Above decks you'll find a steering station on the fly bridge with safe access from both sides for perfect visibility, large sunbathing area, spacious cockpit on same level as the galley, a second cockpit making best use of the forward area, safe and effective transom platforms.

Below decks offers elegance and functionality with exceptionally well lit saloon and cabins, truly luxurious owner's and guests' cabins, U-shaped galley for greater comfort at sea, and so much more.

CATALINA 445

Step aboard this new, fast, comfortable, spacious and safe model from Catalina Yachts.

A truly fresh approach for today's sailor, the sophisticated Catalina 445 incorporates crisp contemporary styling with proportions and features that make all Catalinas comfortable and secure underway and on the hook. Based on a new hull design with a long waterline and moderate beam and freeboard, the 445 delivers excellent performance in a wide range of conditions. The deck is strikingly handsome with a low profile cabin structure, twin helm stations and a roomy cockpit bounded by tall, comfortable coamings.



You'll find the owner's cabin with its private head and separate shower forward, plus the guest cabin aft with a large, comfortable double berth angled for easy access and greater headroom.

CHOOSE
YOUR
WEAPON
WISELY

USA
A2U
2121
PSFS



DOYLESAILS.COM

Doyle San Francisco
Bill Colombo
Josh Butler
(510) 523-9411

Rio 100
Refit by Cooksons
Refit design by Bakewell-White Yacht Design

POWERED BY DOYLE STRATIS SAILS

New Boat Showcase

MELONSEED

With its beautiful lines and smooth rowing, the 16' 5" Melonseed is a great boat for inland lakes and harbors. Rowing enthusiasts will appreciate the available dual sliding seat rowing stations. The sailing model is the best of both worlds for a combination rowing and sailing boat.

The rowing and sailing versions of the Melonseed share an identical hull, but because of the constraints of sailing design, the sailing Melonseed includes

a sealed deck, which effectively increases freeboard. However, there is very little difference in the rowing performance of the rowing and sailing versions.



HANSE 455 – Premiere

Debuting on the West Coast at Strictly Sail Pacific, the NEW model Hanse 455 has everything you would expect from a perfect cruising yacht. Her lines are the creation of Judel/Vrolijk and Co., the best and most experienced yacht designers in the world. This guarantees that she is fast, easy, and safe to sail in any weather condition.



Striking and distinctive like a typical Hanse model, the new Hanse 455 breaks all boundaries.

JEANNEAU 57

Welcome onboard the new Jeanneau 57.

This elegant offshore cruiser offers an exceptional interior and deck plan designed by Vittorio Garroni with ease of handling in mind. Every detail has been conceived to offer the highest quality cruising experience.



Welcome to a new style of contemporary interior that reflects a long nautical heritage. Rich materials are found throughout including leather, blond teak flooring and stainless steel. Sleek windows and skylights bathe the interior in light.

JEANNEAU SUN ODYSSEY 41DS

Hit the docks and discover Jeanneau's Sun Odyssey 41DS. Designed for relaxation and comfort, the Sun Odyssey 41DS also delivers the thrill of responsive sailing.



A spacious owner's cabin aft features a private head and shower compartment and plenty of storage for life on board, offering owners all the luxury of a 45-foot sailboat. Forward, a VIP guest cabin with private head compartment provides guests with the privacy and comfort of home.

Whether you're cruising, living aboard or entertaining friends, you will find functional and aesthetic design in every detail.



Hanse

675 / 575 / 505 / 455 / 415 / 385 / 345 / 325



505



455



415

GERMAN ENGINEERING

Dehler

46 / 41 / 38 / 35sq / 32 / 29



46



38



35sq

PERFORMANCE

Moody

DS62 / DS54 / DS45 / 45AC / 41AC



DS62



DS54



41AC

STYLISH CRUISERS

COME SEE THE HANSE 455 / 505 AND DEHLER 46 AT THE STRICTLY SAIL PACIFIC BOAT SHOW APRIL 9-12 2015 JACK LONDON SQUARE OAKLAND, CA



WWW.JK3YACHTS.COM INFO@JK3YACHTS.COM

1070 MARINA VILLAGE PARKWAY SUITE 109 ALAMEDA, CA 94501

SAN DIEGO, CA 619-224-6200

NEWPORT BEACH, CA 949-675-8053

ALAMEDA, CA 510-227-2100

HOUSTON, TX 281-957-9788

SEATTLE, WA 206-285-6200

New Boat Showcase

RS Aero

The RS Aero is the product of three years of design and development, testing four different hull variations and numerous rig, foil and layout options – resulting in a boat that we are confident is the most technically advanced in its sector.



The RS Aero completely resets the standard for pure exhilaration in a simple singlehander. Ultralight weight means the hull form and rigs need not be extreme, so the RS Aero is remarkably easy to handle.

TOFINOU 8 – Premiere

Designed by naval architects Joubert and Nivelt, and produced in accordance with the shipyard's construction traditions, the Tofinou 8 is a modern sailboat with a classic and timeless line.



Performing well under light wind or a breeze, the Tofinou 8, with its responsive helm, offers sensations similar to those of a sport dinghy. Easy to maneuver alone or with a small crew.

JEANNEAU SUN ODYSSEY 349

From the very first glance, the Sun Odyssey 349 captivates with her pure lines, generous interior volume and inviting cockpit. Designed by Marc Lombard and true to the values of the Sun Odyssey line, the 349 is the perfect combination of performance, comfort and safety at sea. Whether in the cockpit or at the helm, at anchorage or at sea, you will enjoy taking full advantage of this seaworthy, stable and easy-to-handle sailboat.



Escape from the everyday and taste the pleasures of family cruising. With two or three cabins, a spacious saloon and a very functional galley, the Sun Odyssey proves both well considered and inviting. High quality woodwork accents an incredibly bright and well-lit interior.

Come aboard the 349 and enter the world of Sun Odyssey.

WETA

The Weta is a 4.4 meter fiberglass/foam composite trimaran with a boomless main, jib and roller furling gennaker. It can be sailed singlehanded or with four people. When rigged it has a beam of 3.5m, but when put away on its beach trolley, the beam is just 1.7m.



Designed in New Zealand, the Weta is a boat that one person can easily manage on their own – from rigging to sailing in a blow – yet still enjoy performance sailing. There are minimal control lines and it is quick and easy to rig from scratch by one person. Today's Weta is used in an incredibly versatile way, ranging from top one design racing, family day sailing, a sailing resort boat, and for adult and children to learn to sail.

You Belong
on a *Hobie*

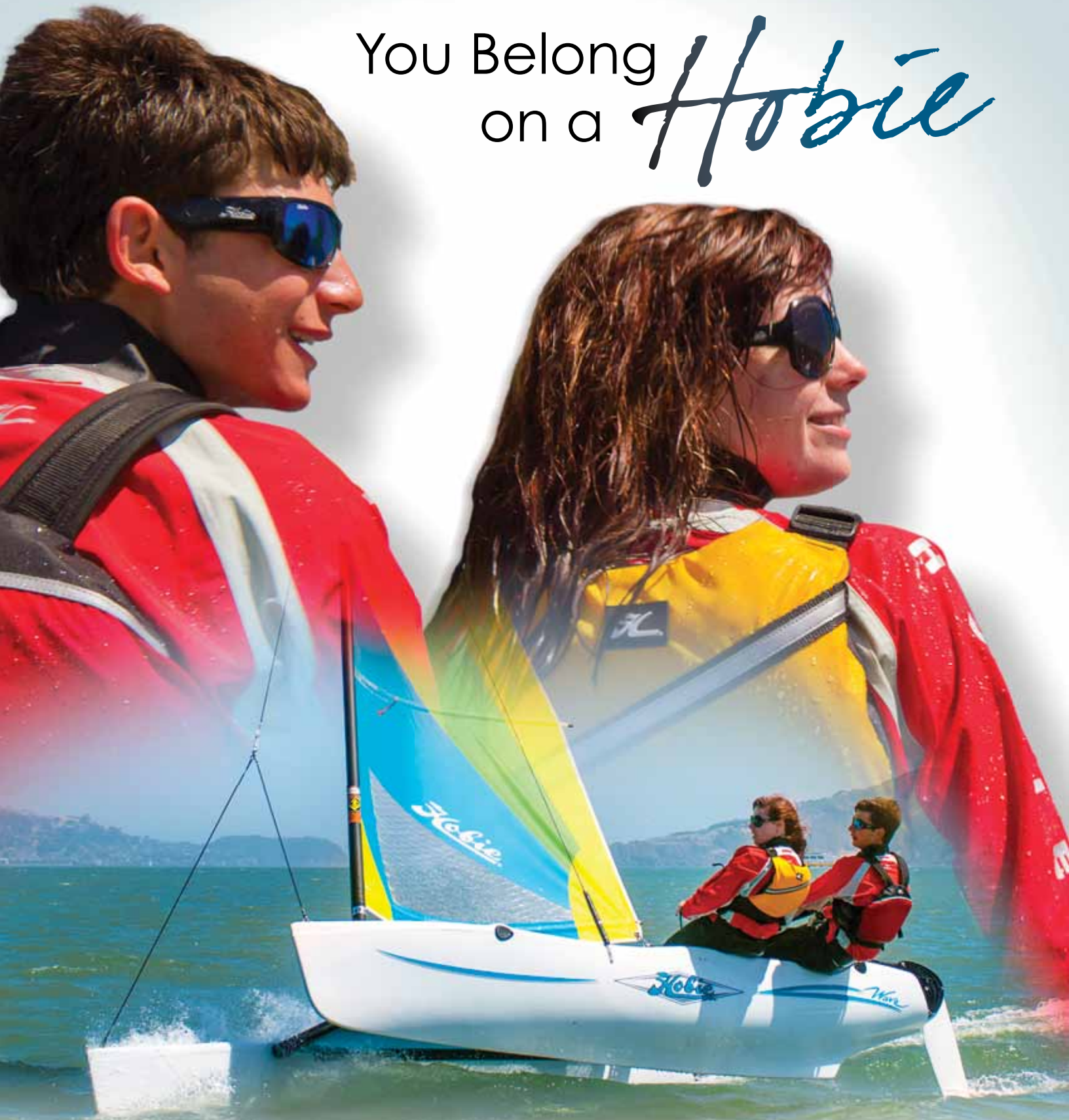

hobiecat.com

Cool New Products

Strictly Sail Pacific is pleased to feature the following products from some of our exhibitors. Please visit their booths and experience them for yourself! For a complete list of new products at Strictly Sail Pacific, see the show website at www.strictlysailpacific.com.

TROGEAR MARINE PRODUCTS – The A-Sprit Adjustable Bowsprit

The A-Sprit is an ideal after-market addition for AS-30 sailboats – up to 30 feet – and the AS-40



PATENT PENDING

sailboats – up to 40 feet – without a bowsprit, and is easier and safer to use than a traditional

spinnaker pole. Fabricated from carbon fiber, the A-Sprit simplifies flying and handling reaching and off-wind sails, and it folds to an upright position when at the dock.

The A-Sprit advantages:

- Simpler to launch downwind sails
- Easier to use during sailing
- Faster jibing
- Less deck clutter
- Stows upright when not in use
- Ideal for Code 0/Asymmetrical Spinnaker

It's a benefit for cruisers, racers, or anyone who wants to improve their sailing experience.

COLLIGO DUX SYNTHETIC STANDING RIGGING

All standing rigging is sized for equivalent stretch and creep. Creep is designed to be less than 0.1" per year (1 inch in 10 years).

This sizing method always results in the rigging being two to five times stronger than existing steel systems. You can expect the factor of safety for the rigging to go from a typical four to eight or more.

The two failure modes of Colligo Dux Synthetic Standing Rigging – chafe and UV damage – present themselves in visual cues. Both chafe and UV damage will show fuzziness in the line. Chafe areas can be covered with a sacrificial cover that can then be changed out when needed to protect the line. UV life can now be predicted to be five to eight years in tropical zones, but will probably improve as more data comes in.



MAGICAZY

MagicEzy 9 Second Chip Fix™ is a revolutionary nano filler that repairs and colors cavities – FAST. Its one-part formula and built-in leveler make it super easy to use. Available in 11 colors. Repairs guaranteed for three years. See it at the AB Marine booth.



PETTIT PAINTS HYDROCOAT ECO

Hydrocoat Eco is the newest member of Pettit's exclusive water-based, copolymer ablative family of bottom paints. The highest level of metal-free ECONEA™ biocide available is combined with a powerful slime-fighting inhibitor to provide unprecedented multi-season protection in the toughest marine environments. Innovative Hydrocoat technology is used to replace the harsh solvents found in most bottom paints with water, providing an easier application and clean up, with low VOCs, and no heavy solvent smell. Visit the Western Marine Marketing booth for complete information.



ANDERSEN WINCHES

In the Svendsen booth you'll see the latest from Andersen winches incorporating their exclusive self-tailing mechanism that automatically accommodates a wide range of different sheet and halyard sizes allowing each winch to serve numerous onboard purposes. From raising sails to trimming sheets, these winches provide the reliable power you need for smooth sailing.





Almar Marinas

Everywhere you'd like to be



Est. 1973



Now Available at
Oakland Marina
Ballena Isle Marina



Join one Almar Marina and enjoy reciprocal privileges at any of Almar's 16 locations from San Francisco to San Diego and out to Hawaii. Each marina provides programs and events that are included in your slip fees:

- *Boat Handling
- *Social Events
- *Electrical Courses
- *Anchor Outs
- *Seminars on Local Destinations

www.almar.com

855.SLIPS 4 U
855.754.7748



Cool New Products

MEGUIAR'S M-19716 MARINE PREMIUM POLISH SEALANT



- Polish designed to restore ALL marine paint finishes. (LP, Awgrip finishes.)
- Safely removes light oxidation, water spots, diesel soot, fine scratches, and restores gloss!
- Protects against damaging UV rays, salt water spots and other environmental pollutants.
- No harsh abrasives and non-staining formula.

Visit the Western Marine Marketing booth.

BOATU.S. APP 3.0 IS HERE!

The upgraded design allows you to view weather and tide tables, locate BoatU.S. towboat ports, switch between day and night time modes, and members can find discounts nationwide on the interactive services locator map.

The App still includes all the great features from BoatU.S. App 1.0, like connecting to the BoatU.S. 24-hour towing dispatch center for assistance on the water or on the road with just the push of a button, and an easy way to display a digital BoatU.S. membership card. Available for free download from the App Store and Google Play™, or visit BoatUS.com/App.



DISCOVER THE DIFFERENCE

- Deep Draft
- Great Location

See us at the boat show to find a new home for your boat.

(510) 236-1013

www.MarinaBayYachtHarbor.com

Cool New *Products*

QUIET TORQUE™

Electric Yacht's successful QuietTorque™ family of 'Clean, Green, Quiet' electric propulsion PMAC motors range from 5kW to 50kW, or from 8hp to 75hp.



They can push boats to 50,000 lbs.

VALVTECT PRODUCTS SOLVE DIESEL FUEL AND GASOLINE PROBLEMS

Marine industry experts agree the best solution to prevent ethanol-related problems, such as corrosion, fuel destabilization and phase separation, is to use an ethanol treatment such as ValvTect Ethanol Gasoline Treatment. It received a perfect 'A' rating to prevent corrosion, and can stabilize ethanol-blended gasoline up to a year or more and help prevent phase separation.

BioGuard Plus 6 is a unique multi-functional biocide/diesel additive that is EPA registered and contains a micro-biocide to prevent bacteria, plus six additional components that can double fuel filter life, stabilize diesel up to two years, lubricate injectors and fuel pumps, and clean up injector deposits to improve power output and reduce fuel consumption – all in one product.

See at the Western Marine Marketing booth.



Mathiesen Marine

For all of your electronics and electrical needs



Raymarine
BY **FLIR**



Visit the Raymarine Mobile Showroom to try the latest technology & Our booth *RIGHT NEXT DOOR* for *EXTRA SAVINGS & REBATES!!!!*



WIN a Raymarine DragonFly!!! Giving away one each day!!!

RIGHT NEXT TO the Raymarine Showroom in *Booth #507*



Professional Sales, Design, Troubleshooting, Installation, Consultation, Education & Surveys for Electronics, Electrical, PC & Mac Based Navigation, Corrosion Issues, Electric Drive Conversions, Solar & Wind Power Systems + More

Emery Cove Yacht Harbor Showroom 3300 Powell Street, Emeryville, CA
Tuesday - Saturday 9:00 a.m. to 5:00 p.m.

510.350.6622

www.MathiesenMarine.com

Cool New Products

TORQTRAC BY TORQEEDO

Existing and new users can upgrade their motor's display with TorqTrac, Torqeedo's new app. It provides easy-to-read battery status, current speed and power use, and remaining range on the display of a tablet or smartphone. Working with Google Maps, the remaining range is also presented clearly on a map. Features such as waypoints and the exact calculation of arrival times ensure boaters always have enough power to complete their trip. TorqTrac is available for IOS and Android devices, and connects to Travel 503 and 1003, Cruise 2.0 and 4.0, and Ultralight 403 motors via Bluetooth with an optional adapter.



ANTAL WINCHES

Looking for winches? Be sure to stop by the Euro Marine booth to learn more about the Antal XT self-tailing winches available in aluminum, chrome-plated bronze and natural-polished bronze. Available in 12 sizes with either manual, electric or hydraulic, Antal's winches are sure to compliment any boat.



See the full line of Antal marine hardware at the Euro Marine booth.

QUALITY, INNOVATION, PERFORMANCE

WORLD CLASS YACHTING ROPES

Visit Us at
Booth # 420-422 at
Strictly Sail Pacific



WR2
Synthetic
Lifelines



HSR
Stronger Than
Steel Fiber Rope

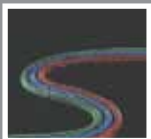

Poly Tec
Aramid Polyester
Cover with
Dyneema Core



**Spinnaker
Furling Line**
Anti-torsion
Furling Cable



TEUFELBERGER FIBER ROPE CORP. 848 Airport Road, Fall River, MA 02720 T: 800-333-6679, www.neropes.com

Cool New Products

CHARGE UP! INTRODUCING THE HYDROMAX 150

Winner of *Sail Magazine's* 2015 Pittman Award for Innovation

The HYDROMAX 150 Marine Fuel Cell showed up on our radar at the Southampton International Boat Show in the UK this past September. Our first thoughts were, "What a cool maintenance-free concept," and "We want this additional source of on-demand power on our boat."

Fuel cells have been around for a long time, although only recently marketed specially for marine use. They are small electrochemical devices that directly convert the chemical energy of a continuous reaction into electrical energy – safely, quietly, and without excessive generation of heat.

The HYDROMAX 150 is an excellent complement to other methods of green power generation on a cruising boat. It is a quiet and reliable way to produce 12V power, anytime and anywhere.

The HYDROMAX 150 is unique because:

- It uses no flammable fuel (no methanol).
- The mixing of two very safe components – a salt and an acid (malic acid, which is found in fruit and used as a food additive) – provides the chemical reaction.
- These fuels are shipped and stored in dried powder form.
- Can produce 300 amps in a 24-hour period.

Hydrovane International Marine, Inc., manufacturer of the Hydrovane self-steering windvane, is now the sole North American distributor for the HYDROMAX 150.

More information: <http://www.hydrovane.com/other-products/hydromax-150-fuel-cell/>



It's time to remember why you liked sailing in the first place.



16' 5" MELONSEED

This modern classic offers exceptional sailing performance plus sliding seat for rowing exercise or exploration.



11' 11" SCAMP

This ultimate microcruiser features offset centerboard, water ballast, and loads of secure dry stowage.

GIG HARBOR BOATWORKS

Building eight different traditional fiberglass rowing and sailing boats from 8 to 17 feet

- Over 2500 hand-built, custom boats shipped worldwide since 1987 •

Gig Harbor Boatworks | (253)851-2126 | PO Box 765, Gig Harbor, WA 98335 | www.ghboats.com

Cool New Products

SAIL-GEN WATER POWERED GENERATOR FOR CRUISING YACHTS

Eclectic Energy Ltd. is pleased to introduce its latest product, the Sail-Gen, a dedicated water generator for cruising yachts and presented at the show by First Mate Marine.



Responding to the increasing interest in hydro generation amongst long distance sailors, Sail-Gen complements Eclectic's existing marine product range, which includes the DuoGen dual mode water/wind generator and the D400 dedicated wind generator.

LEMON & LINE

Lemon & Line handcrafts nautically-inspired bracelets and accessories in 'the Ocean State'.

Using only marine-grade materials, the bracelet is clean and subtle in approach.



Now offering a large selection of styles and colors, Lemon & Line has something for the sailor in all of us. Come see them at the Whitecaps Marine Outfitters booth.

OPTIMUM TIME

Optimum Time is a specialist sports timing company. Established in 1996, the company quickly rose to fame for its 'big yellow timers' in the sports of sailing and eventing.



Complimented by a huge range of normal-sized watches and all with bespoke sailing functions, there is no need to look beyond Optimum Time. See them at the Whitecaps Marine Outfitters booth.

Captain's License

Maritime  Institute

Captain's License Training
Educating Mariners for Over 35 Years

Maritime Institute has a course Near You!
From *San Rafael* to *San Diego*
or *On-line* at your own pace

Stop by our
booth #34 at the
Strictly Sail show

- ✓ OUPV up to 100 GT
- ✓ Able Seaman
- ✓ Radar and Radar Renewal
- ✓ FCC License Exam - MROP
Marine Radio Operator Permit

Toll Free: 888-262-8020
www.MaritimeInstitute.com

RECHARGEABLE

SEE US AT
BOOTH 340-341

SOLAR LIGHTING

*Light up your dock,
deck, cockpit or cabin.*

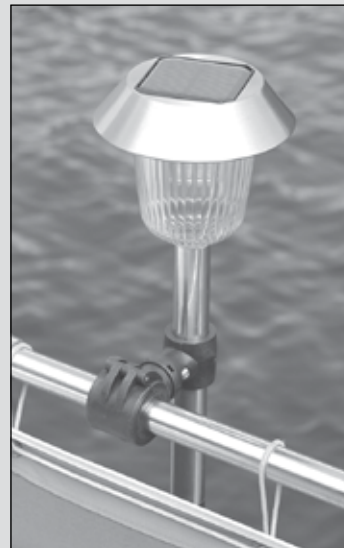

Light up your life with
RailLight™ Premium!

- No Wires
- LED
- Rugged
- Marine-Grade
Stainless Steel
- 3 Mounting Options
Included:
 - Rail Clamp
 - Threaded C-Clamp
 - Wall Mount

Contact us for your **FREE** copy
of the latest catalog from



Davis Instruments 3465 Diablo Ave., Hayward, CA 94545 USA
Phone (800) 678-3669 • Fax 510-670-0589 • Email info@davisnet.com

www.davisnet.com

Cool New Products

STAND-UP PADDLE BOARDS AND LONGBOARD SKATE BOARDS



Based in both San Francisco Bay and Lake Tahoe, Desolation Outdoors manufactures luxury and performance driven stand-up paddle boards and longboard skate boards.

Designed with the modern sailing yacht in mind, the Desolation Fastnet is 14' long, 29.5" wide, and constructed using carbon fiber. This board is fast, stable, light and easy to carry at only 27.3 pounds.

ANCHOR MATE by Mantus Anchors To Better Secure Your Anchor

Anchor Mate guarantees your anchor a snug fit on your bow. Anchors frequently do not fit well on the bow rollers, and boat owners resort to either switching to a sub-optimal anchor design in order to ensure a better fit or investing heavily in expensive custom solutions to better secure their anchor on the bow.



Anchor Mate was designed to mate an existing bow roller with an anchor of any design. Simple install uses the same bolt that articulates your roller, and converts an existing bow roller into a custom bow roller for any anchor. The design incorporates sturdy 316L stainless steel precision casting, polyurethane V-guard from Stoltz Industries, and all 316L fasteners.

Text and photos supplied by Strictly Sail Pacific exhibitors; products selected and text edited by Sail America.

New, Bigger Booth! #342

FEEL THE FREEDOM

With an Independent Self-Steering System AND 'Ready to go' Emergency Rudder

- Your best crew member - doesn't eat, sleep, or talk back!
- No problem to install OFF CENTER - keep your davits or swim step
- No lines in the cockpit connecting to your wheel or tiller
- Have confidence in case of main steering or rudder failure

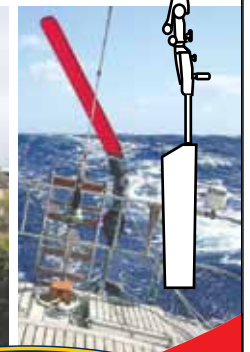

Also Exhibiting:



www.hydrovane.com



STEERING THE DREAM

Show Highlights

Plenty of Fun Things to Do and See!

From the sailing novice to the die-hard racer, Strictly Sail Pacific has something for everyone: the widest selection of sailboats and sailing accessories on the West Coast, an extensive seminar schedule, hands-on sailing clinics, live music and parties.

WELCOME TO THE ALL-NEW DISCOVER SAILING AT STRICTLY SAIL PACIFIC

Take a Sail or a Clinic with Discover Sailing

Sail America is excited to announce that Discover Sailing at this year's Strictly Sail Pacific will have an all-new look. Our goal is to help you improve and broaden your skills, while introducing the great new and innovative boats and equipment that members of Sail America are making available in the sailing marketplace.

Whether you are a cruiser or a racer, thinking about the next boat or that next charter vacation – or looking to try out the latest sailboats offered and learn about their new technologies and sailing styles – check out Discover Sailing and sail the latest boats with our **New Product Introductions Program**. Discover Sailing will have three brand new products that you can test sail: the singlehanded RS Aero, the Beneteau First ASA trainer, and the Beneteau 35. These boats are available on a limited basis at the show. Registration is **free** and only available online at www.strictlysailpacific.com.

To help sailors get the most out of their boats and to feel confident when considering their next boat, we are featuring several hands-on on-the-water clinics led by some of the best instructors in the Bay Area. Pre-registration for these clinics is encouraged, and includes admission to the show for the day of the clinic. (A \$15/pp value.)

Below, you will find full descriptions for all of our Discover Sailing Programs being offered at Strictly Sail Pacific 2015. To learn more or to register for one of these clinics or free sails, see www.strictlysailpacific.com.



Anchoring: This two-hour hands-on clinic will introduce you to such techniques as picking up a mooring ball, setting an anchor properly, setting two anchors, anchoring bow and stern, Bahamian anchoring, Med mooring, selecting the right anchor configuration, what to do about a fouled anchor, the risk of rode in the prop and other issues. Our goal? A good, sound sleep the next time you spend the night at anchor.

Your instructor will be a certified, licensed instructor from Tradewinds Sailing School and Club.

Thursday–Sunday 4:00 p.m.

Limited to four people per clinic.

Online registration: \$95/pp

(\$125/pp for onsite registration.)

Advanced Sail Trim for Cruisers and Racers – North U.:

A half-day clinic designed to help you get the best performance out of your boat. You'll be sailing and trimming under the direction of the coach. Bring your gloves! Topics include: sail trim theory, angle of attack, speed and twist, speed and pointing, sail selection, genoa and main trim, downwind sailing under main and jib, downwind sailing with a spinnaker, and tacking and jibing. Sign up individually or bring your crew.

Thursday–Sunday 9 a.m. and 2 p.m.

Online registration: \$95

(\$125/pp for all onsite registration.)

Additional crew member: \$75; Crew of six: \$400

Catamaran Sailing: During this three-hour clinic aboard a 38-ft Seawind 1160 catamaran, you will learn to maneuver a large cruising catamaran under sail and power. You'll also learn about docking, anchoring, crew overboard, and the general systems of a large cruising cat. Your instructor will be U.S. Coast Guard-licensed master and ASA-certified instructor Dan Seifers. Offered in cooperation with Tradewinds Sailing School and Club.

Thursday–Sunday: 10:00 a.m. and 2:00 p.m.

Limited to six people/class.

Online registration: \$125/pp

(\$150/pp for onsite registration.)



**SVENDSEN'S
BOAT WORKS**

LOW BOAT SHOW PRICING!

Come to Svendsen's Booth #440 for deals on quality items, such as:

Gill Clothing



Lunasea Lighting



Mustang Survival

Mustang Survival is the leading supplier of quality flotation and personal protective equipment to the most demanding maritime customers including commercial Mariners and Recreational boaters.



and many more...

Come visit the Svendsen's expert service technicians at our service exhibit. Discuss any of your boating repair, maintenance, or upgrade needs. We have the products and the experience to answer all your questions!



Booth #440

OPEN 7 DAYS A WEEK!

Chandlery & Rig Shop / 510.521.8454
info@svendsens.com / www.svendsens.com
1851 Clement Avenue, in the Alameda Marina

Docking: This two-hour clinic will enable you to control your vessel in close quarters maneuvering instead of the other way around. It will come in handy every time you depart or arrive at a dock. You will be doing all of the driving as you practice fairway turns and backing the boat, and a series of drills that will lead you to mastery of upwind, downwind, crosswind, portside-to, starboardside-to, bow-to and stern-to docking. Your instructor will be a certified and licensed instructor from Tradewinds Sailing School and Club. Thursday–Sunday 10:00 a.m. and 1:00 p.m. Limited to four people per clinic. Online registration: \$95/pp (\$125/pp for onsite registration.)

Match Racing Clinics: You'll learn about entry, dial ups, circling, lead/push, the hook, the shift right and many other match racing tactics during shoreside sessions – and then head out on the water for drills, exercises, practice starts and races. The clinics are open to men and women, and you can sign up as a team or individually. No prior match racing experience is required, but the course assumes some fleet racing experience. The clinic will be run non-spinnaker on provided boats. Presented in partnership with North U.

Thursday and Friday 9 a.m. to 5 p.m.
Fees – Individual: \$100.
(\$125/pp for onsite registration.)
Additional crewmember: \$75. Team (four people): \$300.

Taste of Sailing: Join us for a four-hour sail on San Francisco Bay and along the way we'll teach you as much or as little as you want about how to sail. We'll have a lively discussion about the types of sailing, the types of sailboats, and what it takes to become a competent and confident sailor. You'll be welcome to participate in steering the boat, trimming the sails, and making proper and safe decisions. Of course, we'll provide you with a complete explanation of the equipment on the boat, and a thorough safety briefing. This four-hour sailing experience will be followed by a short social event so that you can review and relive your on-the-water experience with the friends you've made on board. Thursday–Sunday 9:00 a.m. and 2:00 p.m. Limited to four people per sail. Online registration: \$125/ pp, or \$195/couple. (\$150/pp and \$225/couple for onsite registration.)

If you would like to have a private family, friends, or corporate experience, please contact Gary Edelman, the Sail America Discover Sailing Director, at (414) 944-1550 to discuss your options – or you can email him at: discoversailing@sailamerica.com.

Show Highlights

West Marine®
For your life on the water.

**CRUISING
OUTPOST**

Free Hourly Seminars

West Marine and *Cruising Outpost* are the presenting sponsors for the seminars given by sailing experts and industry leaders. Whether you are getting started in sailing, planning your dream cruise, preparing for the Pacific Cup, or looking to get the most out of sailing on San Francisco Bay, there is a seminar for you. Enjoy seminars on sailing destinations, weather, tides, cruising on a budget, sail trim, voyage planning, electronics, the Baja Ha-Ha, cruising for couples, catamaran cruising, storm strategies and more. With many unique topics, you may want to spend the entire weekend. See page 38 to learn more about featured speakers, and visit www.strictlysailpacific.com for a full schedule of free seminars.



Club Nautique

Shopping Sailing Clubs?

Things you should know about Club Nautique:

- Award Winning Sailing School**
The most thorough beginner to offshore sailing program in the country
- Impressive Charter Fleet**
The largest, newest, best-equipped fleet of sailboats and powerboats on the Bay - Period
- US Sailing Certification Standard**
We are inspected and certified by US Sailing the national governing body for sailing
- Two Great Locations**
Alameda & Sausalito
- Membership Benefits**
Discounted Charters, Discounted Classes, Yacht Club Membership, Events & Cruises

Visit us on the Dock at the
Strictly Sail Boat show
www.clubnautique.net

Alameda 510-865-4700
Sausalito 415-332-8001



Scan here for current special offers

Authors' Corner

Stop by the Authors' Corner and pick up a great new read from your favorite sailing author. Chat with the experts, receive some great advice for your next sailing trip, get a signed book, and hear a tale or two about any number of sailing topics and adventures. Open during show hours.



You just never know who you'll bump into at the boat show, such as the lovely Crissy Fields.

Advanced Seminars

Need more than an hour? In addition to the FREE seminars, Strictly Sail Pacific offers a complete lineup of advanced sailing seminars presented by some of the best sailing authorities in the world. Choose from Pam Wall's Empowering the First Mate seminar, Lin Pardey's Writing, Videos, Blogging – How to Make it Pay, US Sailing's Safety at Sea seminar, or Lee Chesneau's three-hour hands-on skill building Marine Meteorology Weather Course. Turn to page 34 to learn more about the advanced seminar program.



Marina CostaBaja, at the Gateway to the Sea of Cortez in La Paz, South Baja.

Marina CostaBaja’s protected location, concrete docks and double basin design offers controlled access to 250 prime slips for vessels ranging from 30-200 feet.

OUR PRIME FACILITIES

Potable desalinated water • Secure dock boxes • Largest fuel dock in the area • Crew lounge
 Pump out service • 24 hour security • Laundry service

Visit CostaBaja, a master planned community and enjoy Golf or relax at the Beach Club or choose your future home among a variety of Condos, Villas and Townhouses.

Discover the most beautiful bays, islands and marine life in what is known as “The Aquarium of the World”.



COSTABAJA
 Unique living on the Sea of Cortez
 marina • golf • residences

Gabriel Ley (Marina Manager)
 marina@marinacostabaja.com
 Toll Free 888-866-9394
 www.marinacostabaja.com

Show Highlights

Is Mexico Cruising in Your Future?

Mexico has long been the prime cruising destination for generations of West Coast sailors. For 2015, Strictly Sail Pacific is excited to welcome back the Mexico Pavilion, hosted by many of Mexico's premier marinas sharing an extensive program of Mexican seminars and information, plus an exciting program of Mexico cruising seminars.

In the two decades since the first Baja Ha-Ha, Mexican marine facilities and services have improved dramatically, while the warm waters, steady breezes and friendly nature of the traditional Mexican culture have stayed true to their history.



Sailing across the border on your way south you enter a new world full with endless places to explore. Cruisers have written in *Latitude 38* that La Paz on the Sea of Cortez is one of the favorite towns in Mexico as, at its heart, it has changed very little and remains an authentic city. Further down the West Coast of Mexico lie many additional varied, exciting and tropical Mexican destinations.

Additionally, due to its ecologically-rich environment, you will see amazing wildlife, clean waters, and will have numerous new and rewarding experiences exploring Mexico's coastline. Venturing inland you will discover even more of Mexico's many rewards, cuisines, cultures and attractions.



Although there's a big world for cruising sailors to experience, many world travelers say there is no better cruising grounds on earth than the waters of Mexico.

If you are planning to head south this fall – or any time in the future – you will find the Mexico Pavilion staffed with Mexico marina representatives who can answer all your questions and provide you with many insights into your forthcoming Mexico cruising adventures.

Along with the Mexico Pavilion, be sure to check out the Free Seminars with speakers sharing information on their experiences and insights on cruising to Mexico, as well as what to enjoy – and expect – once you arrive.



México

www.visitmexico.com

www.visitlapaz.com

Sail San Francisco Bay

Strictly Sail Pacific 2015 will feature a fun mix of the many one design classes, active fleets, class associations, yacht clubs and community sailing centers that surround us here in the San Francisco Bay Area.

Learn how sailing is an inclusive, affordable – and seriously fun – sport. Chat with local sailors who are happy to share how you can get involved in Bay Area sailing. Discover just how easy it is to learn to sail, find opportunities to crew or sail all over the Bay, meet new friends, and explore San Francisco in a way you can't from the deck of a ferry.

Don't sit on the shore – register online, in advance, for a FREE New Product Introduction sailboat ride.



Get Taken For a FREE New Product Introduction Sailboat Ride
Sailboat rides abound at the boat show, so take advantage.*

*Advance registration required.

ONLY IN MARINA VALLARTA...

352 VESSEL CAPACITY (UP TO 160 FEET), ELECTRICITY, WATER, PUMP OUT, 88-TON TRAVELIFT, DRY DOCK, RESTAURANTS, SHOPS, HOTELS, AIRPORT PRIME LOCATION, COORDINATES: LAT: 20.39 N, LONG: 105.15 W

Marina Vallarta
BAY VIEW GRAND

MARINA VALLARTA
TELS. +52 (322) 221-0275
+52 (322) 221-0722
PUERTO VALLARTA, JAL. MÉXICO

OPEQUIMAR
CERTIFIED MARINA

www.marina-vallarta.com.mx ~ italia@marina-vallarta.com.mx

- EXPLORE -
The Sea of Cortez

La Paz
Baja Sur

www.golapaz.com

f t /purelapaz

México
LIVE IT TO BELIEVE IT
VISITMEXICO.COM

Seminars

Advance Registration and Fee Required

Surface Pressure Map Reinforcement Workshop

Lee Chesneau

Location: Waterfront Hotel, Spinnaker Room #1

Date: Saturday, April 11

Time: 8:00 a.m.–11:00 a.m. **Cost:** \$65

Register at www.strictlysailpacific.com.

This reinforcement workshop takes a closer look at – and examines – more in-depth surface pressure maps.

- There will be a reinforcement exercise built around surface pressure map symbols, beginning with reviewing one's understanding of the surface station plot (wind direction and speed, atmospheric pressure, and current weather conditions (fog, rain, or thunderstorms).
- Attendees will be given an opportunity to practice drawing isobars around surface atmospheric pressure readings from station plots. Then one will learn what it means to identify where low and high pressure systems are.
- There will be a practice learning exercise to consolidate the difference between 'Issued' and 'Valid.' This is important to understanding the 24-hour tracking of directional movement of the low and high pressure centers on the surface pressure from the Ocean Prediction Center (OPC).
- Attendees will practice determining true wind direction and speed from a surface pressure map depicting isobars only.
- Ref: the National Weather Service marine advisory, watch, and warning program. There will be a couple of scenarios for attendees to consider strategy options before, as well as after, leaving the dock.
- Finally, based on reviewing additional surface pressure map symbols (fronts, troughs, ridges), there will be a practice exercise on being able to identify the specific weather conditions associated with the map symbols, such as associated clouds, visibility restricting weather conditions (fog or precipitation types, rain or thunderstorms).

Prerequisite: Attend the Weather Briefing – Assessing Your Marine Weather Self-Reliant Skills free seminar. (See the Free Seminars schedule, to be published in the program available at the show.)



LEE CHESNEAU

500 mb Reinforcement Workshop

Lee Chesneau

Location: Waterfront Hotel, Spinnaker Room #1

Date: Saturday, April 11, 2015

Time: 11:30 a.m.–2:30 p.m. **Cost:** \$65

Register at www.strictlysailpacific.com.

We will break down the different components of a 500 mb chart, considered to be the holy grail of weather forecasting, and then go deeper into your understanding of weather forecasting. In addition to the 500 mb station plot, we will delve into the components of a 500 mb chart (altitude versus pressure), iso-height contours, wind barbs and their spacing, and iso-height labeling.

You will learn:

- To identify upper level troughs and ridges.
- How 500 mb has direct impact on where surface low and high pressure weather systems originate, intensify, weaken, and move (direction and speed of motion).
- To identify and recognize through practice exercises the four (4) basic flow patterns well depicted on 500 mb charts.
- To apply and practice the 500 mb 'rules of thumb' as it impacts surface weather conditions and forecasting, including predicting where the strongest winds on the surface will be.
- To use and exercise the A, B, C, and D zones associated with a 500 mb chart (as discussed in detail in Heavy Weather Avoidance by Chen and Chesneau (www.chesneamarineweather.com/?p=214)).

Prerequisite: Attend the Weather Briefing – Assessing Your Marine Weather Self-Reliant Skills and Unlocking the Mystery of 500 Mb Charts. (See the Free Seminars schedule, to be published in the program available at the show.)

Seminars

Understanding Weather and Cruise Decision Making Workshop

Lee Chesneau

Location: Waterfront Hotel, Spinnaker Room #1

Date: Saturday, April 11

Time: 3:00 p.m.–6:00 p.m. **Cost:** \$65



Register at www.strictlysailpacific.com.

Offshore bluewater cruising on the high seas always involves receiving the marine weather forecast issued from NOAA or other government agencies such as Environment Canada. We will delve into integrating the core weather maps for vessel forecasting and route decision making inclusive of 500 mb, surface pressure, wind/wave analyses and forecast charts.

This course exercise will practice:

- Discussing concepts utilized for long distance voyage planning for both North Pacific and Atlantic Oceans (from pilot charts, to graphical, and text-based marine weather forecasts).
- The importance of developing a culture documentation and verification of 48/96 hour Graphical Forecast Verification Page.
- Utilizing the Graphical Pacific Briefing Page from the Ocean Prediction Center (OPC), to get an understanding of synoptic scale weather through five days (120 hours) by the integration of surface pressure, 500 mb, and Wind and Wave Analyses and Forecasts Charts.
- Connecting that into the local marine weather forecasts through 5-days, along with the marine interpretation message from the OPC.
- Planning a North Pacific Ocean virtual voyage from San Francisco via San Diego and then on to Hawaii.

Prerequisites: Attend the Weather Briefing – Assessing Your Marine Weather Self-Reliant Skills, Unlocking the Mystery of 500 mb Charts, and the Wind and Wave Concepts and How to Integrate the Charts with the Surface Pressure Maps. (See the Free Seminars schedule, to be published in the program available at the show.)

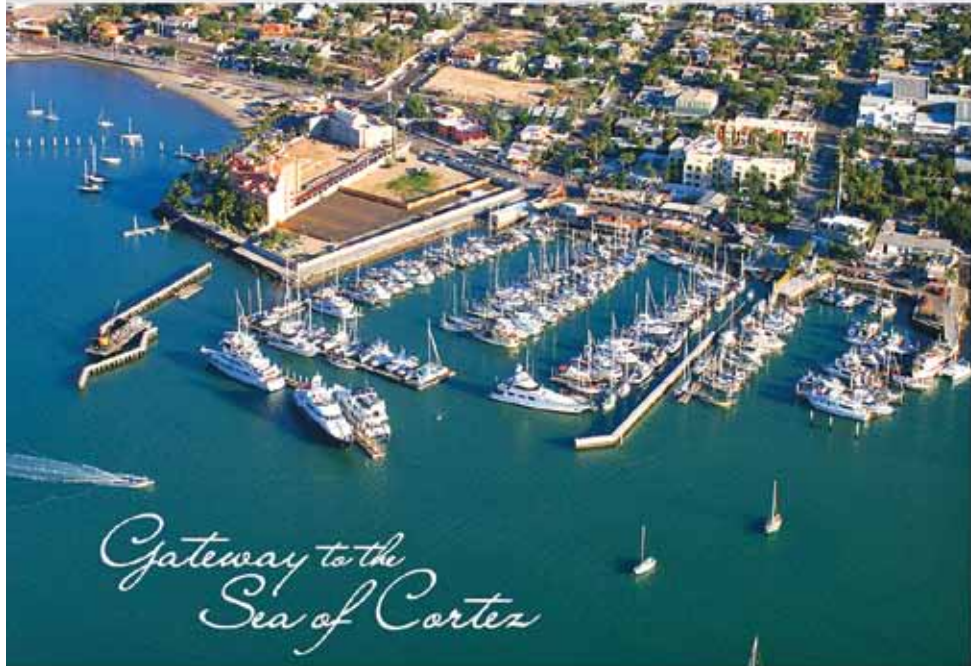

Gateway to the Sea of Cortez

La Paz, Baja California Sur
www.marinadelapaz.com

MARINA DE LA PAZ
Full Service Downtown

MAZATLAN... YOUR MEXICO CRUISING HOMEPORT



CRUISE MEXICO WITH MARINA EL CID STYLE!

A clean, friendly, first class marina with a beautiful climate and rich local culture.



www.elcid.com

011-52 (669) 916-3468
gcevallos@elcid.com.mx

Seminars

Advance Registration and Fee Required

Writing, Videos, Blogging –
How to Make It Pay

Lin Pardey

Location: Waterfront Hotel, Spinnaker Room

Date: Sunday, April 12

Time: 9:00 a.m. to 12:00 p.m.

Cost: \$65/pp or \$110/couple (Limited to 50 people.)

Register at www.strictlysailpacific.com.

Can you top up your cruising kitty by writing? How do you sell that first sailing article? What will make your voyaging blog stand out from the rest? What can you do to keep people watching your videos or reading your blog?

Lin Pardey will share tips and ideas for getting published in magazines and books. She'll tell you how to get noticed by editors, ways to present work that sells and ideas for expanding your markets.

A discussion of what returns you can expect for your work will be included along with the pitfalls and the practicalities of adding writing and photography to your cruising life. Book writing and publishing will be covered, including the realities of self-publishing.

The discussion on creating sailing videos and distribution realities is based on her experience as creator and co-producer of five successful DVD programs. Condensed versions of these programs have appeared on PBS and are streamed on Vimeo and other platforms.



TALEISIN

Lin wrote her first sailing article three years after she started voyaging with Larry on board their 24-foot self-built, engine-free cutter *Seraffyn*. During the next 45 years, literally hundreds of her articles have appeared in magazines around the world. She has, with Larry, written 12 books which have been translated into six different languages and sold more than 350,000 copies. The first seven of her books were produced by major New York publishers. Eighteen years ago she began publishing her own titles, and has begun publishing nautical titles by other sailors under the L&L Pardey logo.

MARINA CORTEZ LA PAZ

*Imagine YOU WERE DESIGNING
THE Perfect MARINA...*

Marina Cortez has a unique combination of old-world service and the most modern marina design in Mexico.

You'll luxuriate in a level of service and comfort that goes beyond other marinas. Imagine a moorage that starts with every boat being assisted by dock staff and continues with exclusive access to a host of services that make Marina Cortez much more than a place to keep your boat. It's a place where you can make the most of every visit to this spectacular area.

Sheltered by a tranquil cove, Marina Cortez has more than 50 slips, ranging from 40' to 300' accommodating even the largest boats cruising the Pacific and the Sea of Cortez.

Everyone with a moorage at Marina Cortez enjoys these amenities and much more:

- Assistance with Immigration and Customs documentation • Cruise planning Services • Information about Doctors and Dentists • Car rental arrangements
- Recommendations for repair services as well as boat maintenance and cleaning.

CONTACT & RESERVATIONS:
Office: +52-612-123-4101 From USA: +52-1-612-157-0013
Fax: +52-612-125-4212 Email: dockmaster@marinacortez.com

Marquez de León # 2415 Esq. Topete C.P. 23060 La Paz, B.C.S. México

Advance Registration and Fee Required

US Sailing Four-Hour Coastal Safety at Sea Seminar

Moderated by Chuck Hawley,
Chairman of the US Sailing
Safety at Sea Committee

Location: Regatta Room 1, Waterfront Hotel

Date: Sunday, April 12

Time: 9:00 a.m. to 1:00 p.m.

Cost: \$65. US Sailing members receive a \$5 discount.
Includes free admission to the show.
Seating is limited.

Register at www.strictlysailpacific.com.

Want to become a better coastal sailor? Want to feel more comfortable as you venture outside the Gate and down the California Coast? US Sailing's Coastal Safety at Sea Seminars are intended for both racers and cruisers who want to improve their offshore safety knowledge.



Topics include:

- Man Overboard Recovery
- Emergency Communications
- Search and Rescue
- Hypothermia
- Breaking Seas
- Personal Safety Gear

Many local races now require attendance at Coastal Safety at Sea Seminars.

Chuck Hawley is a well-known speaker and marine safety expert in the Bay Area. Chuck worked for West Marine for over 30 years, and now serves as the Chairman of the Safety at Sea Committee for US Sailing. He appears in over 500 videos on a variety of marine safety and product selection videos on YouTube, and has recently completed four educational videos on Safety at Sea for US Sailing. His 40,000 miles at sea have taught him to be creative in solving issues regarding boat systems, navigation, safety and rigging.



MARINA CORAL

ENSENADA, BAJA CALIFORNIA



OUR SERVICES

- Fuel dock (diesel & gasoline)
- Customs clearance assistance
- Bottom cleaning & zinc replacement
- At the dock, pump out service
- Fine carpentry & fiberglass work
- Upholstery & canvas work
- Mechanical & electrical repair
- Purified water delivery at request
- Topsides boat wash & detail (wax & buff)
- Marine chandlery



ALSO VISIT
Hotel Coral and Marina and enjoy our bars & restaurants, take a massage in our spa or reserve a suite with a beautiful sea view.

THE BEST ——— MARINA IN BAJA

Longitude 116°39'36.342" W • Latitude 31°51'38.59" N
MORE INFO 1 (866) 302 0066 • marina@hotelcoral.com
www.hotelcoral.com

Free Seminars

Presented by
West Marine®
For your life on the water.

**CRUISING
OUTPOST**

The Strictly Sail Pacific Seminar Series, presented by West Marine and Cruising Outpost, offers more than 90 free seminars during the show! The seminars are taught by highly-respected sailing authors, technical experts and well-seasoned sailors, and cover a wide range of topics. Newcomers and advanced sailors alike will find plenty of topics to expand their horizons, covering everything from learning how to get started in sailing to general boat repairs, living aboard, circumnavigation, and much more!



Seminar Presenters and Topic Highlights

Lin Pardey

Lin Pardey and her lifelong partner Larry have been called, 'the enablers'. Their books and videos have encouraged sailors of all ages to stop dreaming and start doing. The knowledge they share has been earned during the four-plus decades they voyaged together, years during which they completed both eastabout and westabout circumnavigations on board their own self-built, engine-free cutters, *Seraffyn* and *Taleisin*. During their most recent east-to-west voyage, they sailed below four of the great Southern Capes, including Cape Horn. Together, Lin and Larry have delivered more than two dozen boats across oceans and raced on their own and on other people's boats. To date, Lin has sailed almost 205,000 miles.



Lin's articles have appeared in: *Cruising World*, *Sail*, *Good Old Boat*, *Wooden Boat*, *Practical Sailor*, *Yachting World*, *Yachting Monthly*, *Classic Boat* (UK), *Cruising Helmsman* (Australia), *Boating New Zealand*, *South African Yachting*, *Nautica Brazil*, and *Yacht* (Germany).

Andy Turpin

Latitude 38 magazine's managing editor Andy Turpin is a lifelong sailor. In Andy's highly informative Tahiti presentation, he provides an overview of the Tahitian islands and their sister archipelagos, and discusses in detail the annual migration of westbound cruisers called the Pacific Puddle Jump. Andy's seminar on the enormously popular Baja Ha-Ha Cruisers' Rally from San Diego to Cabo San Lucas will make you laugh – and it may even inspire you to cast off your docklines and broaden your horizons.



Lee Chesneau

Lee Chesneau is a highly seasoned senior marine meteorologist with a distinguished 37-year career in maritime weather forecasting, ship routing, and writing. He's a keynote speaker at seminars and a certified U.S. Coast Guard STCW Basic and Advanced Meteorology Instructor.



The final seminar schedule can be found at
www.strictlysailpacific.com

Kimball Livingston

Kimball Livingston has a lifetime of sailing boats and writing about the adventure of it. He is the author of the local classic, *Sailing the Bay*, and his out-of-Bay experiences have taken him to the Andaman Sea, the South China Sea, the Med, the Caribbean, and Fink, Texas. Wearing his journalist hat, Kimball followed the America's Cup around the world until it followed him home to San Francisco Bay, where he blogs at *BluePlanetTimes.com*, writes as Editor at Large for *SAIL* magazine, and co-authored the official book of America's Cup 34, *Sailing on the Edge*.



Bob Bitchin

Since the early '60s, adventure has been a way of life for Bob Bitchin. He worked as a traveling companion and bodyguard for famous motorcycle daredevil Evel Knievel, then, in the early '70s, he started sailing. For more than 30 years, he lived aboard sailboats and cruised most of the Pacific and Central America. In 1996, he created *Latitudes and Attitudes* magazine. More recently, Bob and his wife Jody created a new title, *Cruising Outpost*. He has written seven books: *Letters from the Lost Soul*, *The Sailing Life*, *Brotherhood of Outlaws*, *BIKER*, *Emerald Bay*, *King Harbor*, and *Starboard Attitude*.



Pixie Haughwout and Ralph Folsom

Pixie Haughwout and Ralph Folsom have cruised extensively in the South of France during the summers for two decades. They will share their passions and expertise at the 2015 Strictly Sail Pacific seminars. They welcome you with smiles in Oakland, and at their website www.SeaFeverCruisingGuides.com.



MARINA RIVIERA NAYARIT
AT LA CRUZ

**BEST MARINA IN MEXICO
WITH 354 VESSEL SPACES**

FUEL STATION - DRY DOCK - 150
TON TRAVELIFT - YACHT CLUB

El sueño hecho marina...



Come and enjoy our beautiful marina with first class services surrounded by spectacular views of the Banderas Bay.



"one of the best experiences, no hesitation in letting others know what a great place you have - thanks to all who made our stay so enjoyable"

Andrew Linney, www.nokaoi2.info



LAT 20°45'N / LON 105°24'W

Marina Riviera Nayarit
www.marinarivieranayarit.com
info@marinarivieranayarit.com
harbormaster@marinarivieranayarit.com

Tel. (52) 329 2955526

Cell (52) 322 1350798

Free Seminars

Vivian Matuk, James Muller and Kate Bimrose

Vivian Matuk is the California State Parks Division of Boating and Waterways (DBW) and the California Coastal Commission's (CCC) Environmental Boating Program Coordinator and Clean Vessel Act Education and Outreach Program Manager. Vivian manages the statewide Boating Clean and Green program led by DBW and implemented in partnership with CCC. The program promotes environmentally sound boating practices to marine business and boaters. To implement this program, Vivian works with boaters and boating facility operators. Vivian has a bachelor's degree in biology from the Pontificia Universidad Javeriana in Colombia, South America and a masters in geography concentration in Environmental Management and Natural Resource Planning from San Francisco State University. Vivian previously worked with the Bay Conservation and Development Commission. She also worked with the National Coffee Research Center in Colombia developing eco-toxicological tests to measure the impact caused by coffee-processing wastes.

James Muller is an Environmental Specialist with the San Francisco Estuary Partnership and implements the Clean Vessel Act Program. This program, funded by the California Department of Boating and Waterways, works with marinas, boaters, and other stakeholders to increase awareness of the effects of sewage discharge and resources available to boaters and marinas to prevent sewage discharge. James has a Bachelor of Science in biology from Radford University and a Master of Science degree in environmental management from the University of San Francisco. James also writes grants and manages a suite of environmental projects ranging from restoration and remediation to invasive-species control and TMDL implementation.

Kate Bimrose is the Boater Outreach Specialist for the Seabird Protection Network, performing outreach to boaters and kayakers to minimize disturbance to seabirds at breeding and roosting sites along the California coast. As the Boater Outreach Specialist, Kate disseminates education materials at partner meetings, boat and kayak shows, and boating/kayaking stores. Through these tasks Kate works to strengthen existing partnerships and establish new partnerships with store owners, members of the public, state agencies, and other organizations performing outreach to boater audiences. Kate received her undergraduate degree from UC Santa Barbara and a Master of Science degree in environmental management at the University of San Francisco.



Pam Wall

Pam Wall worked at the West Marine store in Fort Lauderdale for 20 years. She and her husband Andy built their own Freya 39, *Kandarik*, and sailed it



around the world with their two small children. Now a cruising consultant, Pam helps cruisers around the world get the products they need. Pam offers advice and friendship as well as supplies for the yachtsmen and women out there on their boats.

Kame Richards

Kame Richards is a sailmaker and sail designer at Pineapple Sails, which he co-founded in 1973. Pineapple Sails makes both racing and cruising sails, building them from start to finish at their facility in Alameda, CA. Kame's racing experience covers San Francisco Bay, the California coast, 10 Hawaii races, eight Mexico races, and races in the Great Lakes, Florida, Texas and Europe. He has cruised in Mexico, New Zealand and Australia. He has a well-established reputation as a lecturer on all aspects of sailing. Kame attended UC Berkeley, majoring in geophysics.

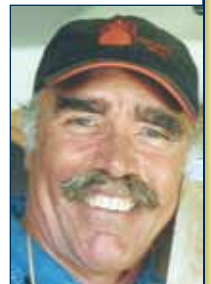

Presented by
West Marine
 For your life on the water.

**CRUISING
 OUTPOST**

Gino Morelli

Gino has been entrenched in onshore and offshore race-boat construction efforts since the early '80s, designing and managing the construction of a French 60-ft ocean-racing catamaran, multiple Formula 40s, the 1988 *Stars and Stripes* America's Cup catamaran, Bol d'Or racers, Little America's Cup C-Class cats, and many racing beach catamarans. He raced extensively on *Stars and Stripes* '88 with Dennis Connor. Morrelli and his partner Pete Melvin designed Steve Fossett's *PlayStation*, helped design 2010 America's Cup winner *Oracle BMW*, and were part of the Emirates Team New Zealand 2013 America's Cup design team. MM also designed the Nacra 17, the catamaran selected for the 2016 Olympics. Today Gino manages the product development side of the business, where he helps bridge the gap between design and engineering.



Sarah and Will Curry

Sarah and Will Curry began talking about an offshore sailing adventure on their first date. Despite their similar personalities and dreams, they had very dissimilar boating experiences. Will had already sailed offshore but Sarah didn't know the difference between a sheet and a halyard!



Since setting out to accomplish their dream in 2012, they've voyaged thousands of miles together, been scared, been amazed, done things they never imagined – and have had the time of their lives. That is, until they set out to do it again...

The final seminar schedule can be found at
www.strictlysailpacific.com.

Gori propeller

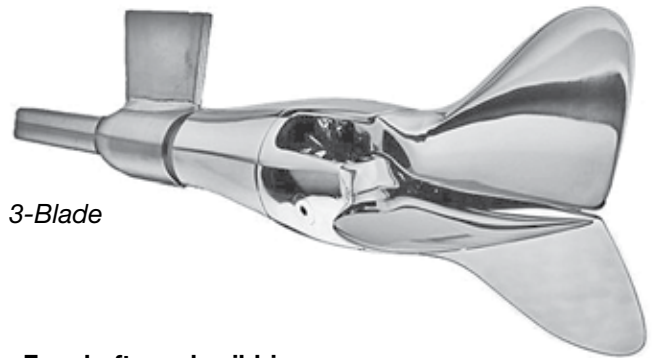

3-Blade

- For shafts and saildrives
- Both 2 & 3 blade available
- Lowest drag when sailing
- The champions choice



747 Aquidneck Ave.
 Middletown, RI 02842

401-847-7960

Fax: 401-849-0631

sales@ab-marine.com

www.ab-marine.com

CALL US TODAY!

800-801-8922

SHAFT SHARK

*The best rope,
 line and debris
 cutter there is!*



401-847-7960
 sales@ab-marine.com
www.ab-marine.com

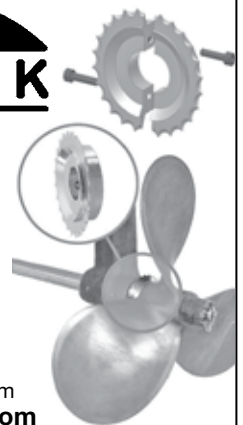

Fix & Color Fiberglass in Seconds



sales@ab-marine.com

sales@ab-west.com

Free Seminars

Thomas Perry

Thomas holds a U.S. Coast Guard 100-Ton License with Towing and Sail endorsements. STCW certified, he's also certified by US Sailing to teach all curriculum courses including Coastal Passage Making – and he's one of Club Nautique's Lead Instructors, partly because of the number of students he's certified as Coastal Passage Making sailors.

Captain Perry has taught for Club Nautique since 2006 and has logged nearly 100 days on Club Nautique Coastal Passage Making classes. He is the owner of a 52-footer that he sails on the Pacific Coast every month of the year.

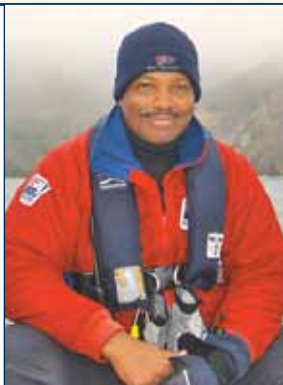

John Arndt

John Arndt, associate publisher of *Latitude 38* and founder of Summer Sailstice, will entertain with stories and adventures from more than 25 years with the magazine – and a lifetime of sailing.

Arndt grew up sailing in Maine and, since then, has taught sailing, raced and cruised oceans, spent almost 30 years in the sailing industry working with *Latitude 38*, the Baja Ha-Ha, Sail America, SailSFBay and founded Summer Sailstice.

The early years sailing in Maine, a year-long cruise to the Caribbean and other sailing exploits inspired John to share sailing with more people and to mobilize sailors to help restore oceanic health with a collective circumnavigation on Summer Sailstice. He feels together we can show why sailing is awesome, good for sailors and the sea.



Don Durant

Don is the founder and CEO of Club Nautique, a sailing school and charter club founded in 1980, with San Francisco Bay locations in Alameda and Sausalito. He has sailed most of his life and been active in the marine industry since 1968.

He is a California-licensed yacht and ship broker and holds a merchant marine master's license.



James Lambden

James Lambden is a marine electrician with 39 years of sailing experience. Owner of the Electric Propeller Company and designer of the E-7, E-11, I-20 and I-30 Electric Drives, Lithium and Lead Acid Management Systems and Marine Solar Arrays, James will be sharing his knowledge with show goers during his four seminars. He is a member of ABYC.



Presented by

 **West Marine**[®]
For your life on the water.™

CRUISING
OUTPOST

The final seminar schedule can be found at
www.strictlysailpacific.com

Pat & Carole McIntosh and Phil & Norma McCaleb

The McCalebs and the McIntoshes each have roughly 40 years of sailing under their belts. Their sailing resumes include having sailed thousands of miles in the South Pacific, the Caribbean, and, more to the point of this seminar, the west coasts of North and Central America. In the process, both couples have made multiple trips up and down the coasts of California and Mexico, including several Baja Ha-Ha's and Baja Bashes. These sailors will not only guide you down the Pacific coast, but can answer any land-based questions you may have – roads, airport connections, shopping – to ensure you get the most out of your trips south of the border, for either extended cruising or commuter cruising.

The primary focus of their seminars is to help prepare you for cruising, and take you safely and comfortably through towns and villages of the Sea of Cortez and the coastal waters of Mexico. They can also introduce you to voyaging as far south as Panama.



Pat and Carole McIntosh

They have conducted cruising seminars together for several years, helping hundreds of other sailors prepare for cruising. Their cruising logs, seminar notes, information on recent regulation changes, and constant input from active cruisers, have ultimately culminated in the creation of their book, *CRUISING NOTES – Things to Know Before You Go*. It contains an invaluable collection of cruising tips, data, and useful information that is not available anywhere else condensed into only one source.



Phil and Norma McCaleb

They invite you to join-in, ask questions, and participate with them as they help you

prepare for your sail of a lifetime, to wherever the wind blows!

SPINEX

SPINNAKER FURLER

The Only Top-Down Spinnaker Furler With Balls

NEW



exclusive Sail Bearing™ technology eliminates binding and reverse furling for unbelievable smooth sail control

Complete Plug-&-Play System
Includes Advanced Features



large drive diameter drum for superior mechanical advantage



easy furling line engagement for easy deployment and storage



one-button luff line attachment for safe and fast sail changes

easily owner installed
in minutes with no tools



www.profurl.com

Let's Party

Celebrate TGIF

Friday, April 10, from 6:00 to 8:00 p.m.

Friday evening spells extra fun as exhibitors kick back and throw one big party for show-goers. Show tents and booths are lively and full of great opportunities for sailors seeking the best deals, all while you're having a terrific time. Start the weekend with a bang at Strictly Sail Pacific!



Baja Ha-Ha, Pacific Puddle Jump and Circumnavigators' Reunion

Friday, April 10, from 6:00 to 8:00 p.m.

The crew of *Latitude 38* invites all Baja Ha-Ha veterans, Pacific Puddle Jump vets, and West Coast circumnavigators – plus anyone who wishes they were, or hopes to be someday – for a reunion party on Friday, April 10, at *Latitude 38*'s Strictly Sail Pacific booth #219. Swap some tall tales about cruising Central and South America, the Caribbean, and the South Pacific, and see who's completed a circumnavigation. *Latitude 38* will bring some snacks and beverages. You bring your smile and your memories.

Latitude 38



Pacific Cup Mai Tai Party

Saturday, April 11, following Pacific Cup Seminar

Easom Racing and Rigging and Pacific Cup Yacht Club are joining forces to host a 2016 Pacific Cup Mai Tai Party on Saturday following the Pacific Cup Seminar (see Seminar Schedule).

Come to booths 332/334 to meet race veterans and see why you should join the FUN race to Hawaii.



Don't Miss the Cruisers' Party

Saturday, April 11, at 7:00 p.m.

About a dozen years ago, Bob Bitchin and Jody of *Cruising Outpost* created the Cruisers' Party at Strictly Sail Pacific. Cruisers come from all over to enjoy this annual celebration of the cruising lifestyle. Eric Stone will be live and in concert, and free beer, wine, soft drinks and pizza will be available. Great raffle prizes, with Grand Prizes from Spectra Watermakers, Dream Yacht Charter in Martinique, and WinchRite!

The event is free and open to all show attendees and exhibitors. It starts when the show closes at 7:00 p.m. You must be in the show prior to show closing to attend. Be part of the biggest, most fun sailing party of the year!

**CRUISING
OUTPOST**



Spinnaker Sleeve



Tacker

The SPINNAKER SLEEVE and the ATN TACKER

The oldest, safest, proven method of spinnaker handling.

- Works at any angle of sail
- Thousands of satisfied customers
- Winner of the Vendée Globe singlehanded around-the-world race.
- Made in the USA since 1985!



SERIOUS SAILING EQUIPMENT

1 800 874 3671 | atninc@hotmail.com

www.atninc.com

Approved in California

COPPER COAT



The 10+ Year Anti-Fouling Paint

Protecting boats around the world for 24 years.

Yes, Coppercoat really works where you are!

1.321.514.9197

www.coppercoastusa.com

License #0E32738

TWIN RIVERS
MARINE INSURANCE
AGENCY, INC.

"Your Marine Insurance Specialists"

7 Marina Plaza • Antioch, CA 94509 • At The Antioch Marina
Latitude 38° 01' 10" N - Longitude 121° 49' 10" W - Buoy 4 Red - On the San Joaquin River

- Shop Your Renewal & Save - Flexible Survey Requirements
- Broad Navigation Areas • Liveaboards • Classic Yacht Coverage
- Agreed Value Policies • Fuel Spill Liability • Get a Quote Online



Bob

Gary

Your Twin Rivers Policy Comes With an Agent

West Coast • Hawaii • Mexico • East Coast

Marine Insurance made simple, affordable and effective.

www.BoatInsuranceOnly.com (800) 259-5701

Years of unbeatable experience to match your needs to the right product.



Commercial Marine Insurance • CALL DOUG for a QUOTE

- Marinas/Resorts
- Dealers/Brokers
- Charter/Tour/Fishing Vessels
- Boat Builders
- Marine Products Manufacturers
- Yacht Clubs
- Vessel Repair Facilities
- Rental Vessels/Workboats
- Marine Contractors
- Wholesalers & Distributors

Doug Rader Your Commercial Marine Specialist • Direct 209-334-2858

Members:



Exhibitors by Brand

In Alphabetical Order

48° North
 AB Marine, Inc.
 ACE
 AGM Energy Management System
 AME - Capt. Robert McCreary
 ATN, Inc.
 Adler Barbour
 Afterguard Sailing Academy
 Air Head Toilet
 American Battery
 American Marine Training Centers, LLC
 American Sailing Association
 Anchor Rescue
 Andersen Winches
 Antal
 Asia Pacific
 Aurinco, Inc.
 Autohelm Windvane
 Autoprop Propellers
 B&G
 BAADS
 BVI Yacht Charters
 Backrest Cushions
 Bainbridge Int'l / Bainbridge Marine Hardware
 Balmar
 Bay Area Boat Loans
 Beneteau America
 Beta Marine West
 Bitchin, Bob, Books & DVDs
 Boat Leather
 Boaters
 BoatU.S.

Boatswain's Locker
 BottomSiders
 Brown, Bruce & Associates
 C Cushions
 C-pod
 CPT Autopilot
 CPX Windlasses
 California Corrosion Concepts
 California State Parks Division of Boating and Waterways



Cali-Optics Importers
 Cape Hatteras Marine, Inc.
 Cape Horn Marine Products
 Catalina Yachts
 Catlin Insurance
 Chart Metalworks
 City Yachts
 Classic Eyewear
 Click Heat, Inc.
 Climma
 Club Nautique
 Co-Logo Wear
 Coamingsider
 Coastal Climate Control
 Colligo Marine

Constrictor Textile Rope Clutch
 Coppercoat USA, LLC
 Cruisair
 Cruise RO Water and Power
Cruising Outpost
 Cruising Yachts
 Curtis Instruments
 Danmer Custom Shutters
 Dash Hemp Santa Cruz
 Davis Instruments
 Delta Anchors
 Desolation Outdoors
 Discovery Yachts
 Dometic
 Doyle Sailmakers
 Dream Yacht Charter
 Dubarry of Ireland
 Easom Racing and Rigging
 Electric Motorsport, Inc.
 Electric Propeller Company, The
 Electric Yacht
 Electroprop Generators
 Ella Vickers, Inc.
 eMarine Systems
 Encinal Yacht Club
 Espar
 Essex Credit Corporation
 Euro Marine Trading, Inc.
 Evolution Autopilots
 FLIR Night Vision
 FSE Robline
 Farallone Yacht Sales

Fastnet
 Fenda Sox
 Fiorentino
 First Mate Marine, Inc.
 Flitz International
 Forespar
 Frigoboat
 Furuno
 Fusion
 Future Fibre Composite Rigging
 Gale Sail
 Garhauer Marine
 Garmin International
 Gig Harbor Boat Works
 Gill North America
 Globalstar
 Gore-tex
 Gori Propellers
 H&C Marine / CEMA
 HRO Systems
 Handcraft Mattress
 Harbor Products
 Harken, Inc.
 Helly-Hansen
 Helmut's Marine
 Henri Lloyd
 Hi Performance Electric Vehicle Systems
 Hook & Moor
 Hooksider
 Hump Helm
 Hydrovane Self Steering, Inc.
 Hylas Yachts

Please check our website at
www.strictlysailpacific.com
 for updated exhibitor listings, boats
 on display, and seminar information.

Icom
 Imtra Marine LED Lighting
 Infinity Fabrics
 Intellian
 Iris Innovations
 Iverson's Designs / i-Top Dodgers
 JK3 Nautical Enterprises
 Jeanneau
 Jefa Jewelry
 Johnson, C.S.,Co./ Johnson Marine
 Johnson Hicks Marine
 KKMI
 KVH
 Kabola
 Kanberra

Kipor Portable Generators
 Ko Lipe
 L&S
 Lagoon America
 Latitude 38 Publishing, LLC
 Leukemia Cup Regatta
 Lemon & Line
 Lewmar, Inc.
 Lifeline Batteries
 Lithium Pros
 Lofran Windlasses
 Lowrance
 MagicEzy
 Magnum Energy
 Majestic TV/DVD



Mantus Anchors, LLC
 Marina Bay Yacht Harbor
 Marine Eco Coating, Inc.
 Mariner Square Drystack & Marina
 Mariners General Insurance Group

Mariner's School, Inc.
 Maritime Institute, Inc.
 Markel
 Marlow Ropes
 Mastclimber
 Mastervolt
 Mathiesen Marine
 Max-Prop
 McMurdo
 Meguiar's
 Mercury Marine
 Mexico Tourism Board L.A.
 Modern Sailing Academy
 Motenergy
 Muir Windlasses

Better Winches Better Sailing

Heading to Strictly Sail Pacific?
 Best prices of the year and a free QuickLock winch handle with every Andersen winch purchase. Visit **booth #429** for details.



www.andersenwinches.us



Exhibitors by Brand

Multihull Company, The
 Multihull Nets
 Multihulls Direct Corp.
 NKE Marine Electronics
 Naos Yachts, Inc.
 Nautos USA
 Navico
 New England Ropes
 New Found Metals
 Nightvision
 Norsap Table Pedestals
 North Beach Marine
 Canvas
 North Sails
 Nova Kool
 Oakland Yacht Club
 Odorlos
 Onyx Inflatable Life
 Jackets
 Optimum Time Sailing
 Watches
 PSP Tapes
 PSS Shaft Seal
 PYI, Inc.
 Pacific Crest Canvas
 Pantaenius America Ltd.
 Passage Yachts
 Pettit Paint
 Philippi
 Pineapple Sails
 Plastimo Life Rafts and
 Safety Equipment
 Porta-Bote International
 Primaloft
 Principal Financial
 Group
 Progressive
 Quantum Sail Design
 Group
 Quickline
 R&D

RS Sailing
 Railsiders
 Raptor Deck
 Raymarine, Inc.
 Recreation Publications
 Reckmann
 Renewal by Andersen
 Rhineland Cutlery
 Robship
 Ronstan International
 Rum Reggae
 Saddle Helm
 Sage Marine, LLC
 Sail California
 Sailology, LLC
 SailSFBay.org
 Samson Rope
 Technologies
 San Francisco Estuary
 Partnership
 Save Our Shoes
 Scanmar International
 Seacoast Marine
 Finance
 Seafire
 SeaTech Systems
 Seaview
 Seaworthy
 Sevcon
 Shaft Shark
 Simrad / Lowrance
 Solara
 Solbian
 Sonihull
 Southern California
 Marine Enterprises
 Spade Anchor
 Spectra Watermakers
 Spinlock Ltd.
 Spinnaker Sleeve

Standard Horizon
 Star Marine
 Electronics, Inc.
 Stohlquist Waterwear
 Swi-Tec America, LLC
 Summer Sailstice
 Sunbrella
 Suzuki Marine
 Svendsen's Marine
 Swedish Marine
 TT Bow Thrusters



Tacktick Instruments
 Tacker
 Teflon
 Teufelberger
 ThunderStruck Motors
 TopKnot
 Torqeedo, Inc.
 Treadmaster
 Tradewinds Sailing
 School and Club

Trident Funding
 Corporation
 Trogear Marine Products
 Twin Rivers Marine
 Insurance Agency, Inc.
 U-Line
 USCG Auxilliary
 USCG-Approved Captain's
 License Courses
 Upscale Hemp Clothing
 Vaavud
 Variprop Propellers
 Velox
 VetusMaxwell, Inc.
 Victron
 Viking Life-Saving
 Equipment
 Vitri Frigo
 Volvo Penta
 Wallas
 Wave Wi-Fi
 Webasto
 West Coast Sailing
 Western Marine
 Marketing, Inc.
 Weta Marine
 Whale Research Institute
 Whitecaps Marine
 Outfitters
 WinchRite
 WINSLOW® LifeRaft Co.
 Xantrex
 Yale Cordage
 Yachtbedding.com
 ZHIK

Please check our website at
www.strictlysailpacific.com
 for updated exhibitor listings, boats
 on display, and seminar information.

Max Ebb's Rules of the Boat Show

- Go early. If you go on the weekend, be there first thing on Saturday while the salespeople are still fresh.
- Go alone. If you go with friends, split up. You'll want to stop and talk to people and anyone you're with will be bored to tears.
- Stay till closing — you might just find a party.
- Wear comfortable shoes that slip on and off easily.
- If you want to have fun pretending to be a newbie, don't wear anything with a boat name or sailing-related logo. A belt with code flags or a Hawaiian shirt with artsy sailboats (half of them upside down) is perfectly fine.
- Stop by *Latitude 38's* booth to have your photo taken with Crissy Fields.
- Always go to the biggest boat first before it gets crowded.



Not only do you get to check out all the latest gadgetry at a boat show, but you often run into longtime sailing friends.

Yacht Insurance as
unique as your yacht



PANTAENIUS
Yacht Insurance

USA* · Germany · Great Britain · Monaco · Denmark
Austria · Spain · Sweden · Australia

inquiries@pantaenius.com · pantaenius.com

Travel and Contacts



ACCOMMODATIONS

Official Hotel of
Strictly Sail Pacific 2015

The Waterfront Hotel
(510) 836-3800
www.waterfronthoteloakland.com

The Waterfront Hotel welcomes visitors to the Strictly Sail Pacific Boat Show at Jack London Square, Oakland.

The Waterfront Hotel blends the unique atmosphere of the Oakland waterfront with modern and luxurious designs, featuring upgraded guest rooms, lobby, meeting spaces, exterior painting, and our restaurant, Lungomare.

SAN JUAN ISLANDS



Weeklong Learn-N-Cruise

Fly to Bellingham, WA, and complete your American Sailing Association Basic Sailing through Bareboat Certification during a liveaboard week exploring the spectacular San Juan Islands. Tuition \$1695 (including food) – plus \$200 Off with *Latitude 38* Special! (Roundtrip air approx. \$350.)

No experience like this for the price in the SF Bay Area!



CHARTER
35 Exceptional Yachts
from 34 to 49 feet

32 Years of Sailing Excellence

We certify more Bareboat Skippers than any other school on the West Coast!

1-800-677-7245 • www.sanjuansailing.com

15% DISCOUNT
DURING STRICTLY SAIL PACIFIC

Sailing vacations made simple..!

BVI YACHT CHARTERS

A boutique charter company with over 30 years experience in bareboat, crewed and skipper only charters. Known throughout the industry for our excellent customer service, impeccable boat maintenance and a crew that will make you feel like family.

T: 888 615 4006 or +1 284 494 4289
Email: charters@bviyc.com

www.bviyachtcharters.com
BOOTH 203 Strictly Sail Pacific

AIRPORTS

Oakland International Airport (OAK) (510) 563-3300
San Francisco International Airport (SFO) (650) 761-0800

AIRPORT SHUTTLES

Bali Limo 1 (415) 957-1888
Quake City Airport Shuttle 1 (415) 255-4899
Robertson's Limo 1 (415) 775-6024

OAKLAND RESTAURANTS

Bocanova (510) 444-1233
Hahn's Hibachi (510) 628-0718
Haven (510) 663-4440
Il Pescatore (510) 465-2188
Jack's Oyster Bar and Fish House (510) 271-7952
Kincaid's Classic American Dining (510) 835-8600
Lungomare (510) 444-7171
Plank (510) 817-0980
Scott's Seafood Restaurant (510) 444-3456
The Forge (510) 268-3200
Yoshi's at Jack London Square (510) 238-9200

SHOW VENUE

Jack London Square
Embarcadero and Broadway (510) 645-9292
Oakland Convention and Visitors Bureau (510) 466-6455



More Oakland Hotels

Claremont Resort (800) 551-7266
Clarion Suites Lake Merritt (510) 461-9829
Courtyard Marriott (510) 625-8282
Rodeway Inn (Alameda) (510) 521-8400
Days Inn (Oakland Airport) (510) 568-1880
Executive Inn and Suites (510) 536-6633
Extended StayAmerica (Alameda) (510) 864-1333
Hampton Inn (Oakland Airport) (800) HAMPTON
Homewood Suites (510) 663-2700
Inn at Jack London Square (510) 452-4565
Jack London Inn (510) 444-2032
Marina Village Inn (Alameda) (510) 523-9450
Motel 6 Embarcadero (510) 436-0103
Oakland Airport Hilton (510) 635-5000
Oakland Marriott City Center (510) 451-4000
Washington Inn (510) 452-1776

BOAT LOANS

from

Trident Funding

"a fresh approach from people you can trust"

See Us At Booth 427



Jack London Square • April 9-12

Please call or stop by for a quote

JOAN BURLEIGH

(510) 749-0050 • (800) 690-7770

Loans will be arranged or made pursuant to a California Finance Lenders License #605 1871.

AFTERGUARD SAILING ACADEMY



SF Bay Skipper 101-103
Pkg \$995-1145

**Great School,
Affordable
Prices –
Big Heart**



Couples learn together –
families too!

**ASA Certification
challenges welcome**



Get ASA Certified for
Charter Adventures
Keel to MH.
*Our boats have character.
Lean and play on boats
big and small.*

First Time, Corp and Family Options:

- 90-minute Introduction to Sailing
- SF Bay Experience – 3 hour Sailing Tour
Return to urban winery for tastings
- Sparkline Sunset Sails – TI or Oakland
- Two-Day Competent Crew Course

When READY, LET'S SAIL:

- Multi-weekend
or Liveaboard
five to seven day
weeks
- Five-day Coastal
Experience for
ASA-106
- ASA Instructor
Clinics by
Captain Mary



Zero to Ocean –
Cruisers Programs



Cruising Camps for Kids.
Small & keelboat.
5-day plus after-care.
No yelling – just fun.

Central Basin Marina in Oakland & TI
(510) 535-1954 • www.afterguard.net

Travel and Contacts

PUBLIC TRANSIT

AC Transit (Alameda and Contra Costa Counties bus service connecting the East Bay and SF) 511
 Airport Transportation 511
 Alameda/Oakland Ferry (510) 522-3300
 Amtrak Passenger Trains (800) 872-7245
Amtrak offers a 10% discount off the best available rail fare to Oakland Jack London Square between April 6-15, 2015. To book your reservation call Amtrak at 1 (800) 872-7245



or contact your local travel agent. Conventions cannot be booked via Internet. Please be sure to refer to Convention Fare Code X28W-926 when making your reservation. This offer is not valid on the Auto Train and Acela Service. Fare is valid on Amtrak Regional for all departures seven days a week, except for holiday blackouts. Offer valid with Sleepers, Business Class or First Class seats with payment of the full applicable accommodation charges.

BART (Bay Area Rapid Transit connecting San Francisco, Daly City, SFO and 25 East Bay cities)
 (650) 992-2278 or (510) 465-2278

Blue and Gold Fleet (Ferry from SF to Alameda and Oakland, Alcatraz, Angel Island, Sausalito, Tiburon, Vallejo/ Six Flags Discovery Kingdom, Bay cruises, and ferry/bus packages to Muir Woods and the wine country) 1 (415) 705-8200
 Golden Gate Transit (Marin and Sonoma Counties bus; ferry from Sausalito and Larkspur to SF) 1 (415) 455-2000
 Greyhound Bus (800) 231-2222
 Muni (SF Bus and Cable Car) 511 or (415) 673-6864
 Regional Transportation Information 511

Uber – FREE Rides!

Request a ride with the tap of a button! Take Uber to or from the Strictly Sail Pacific Boat Show this week. Uber is offering new users a free first ride (up to \$25). Just enter promo code SSPAC15 when you sign up in the app, or text SSPAC15 to 827-222.



You can also sign up at <http://www.uber.com/go/SSPAC15> and download the app for Android, Blackberry, or iPhone. Then sit back and enjoy the magic of Uber, everyone's private driver. (Valid for new users only, TAXI excluded.)



Bringing the comfort of home to your boat!



- Custom-fit sheet sets
- Custom boat mattresses and toppers
- Window treatments, bedspreads and duvets
- Complimentary measuring

(213) 254-5835

www.YachtBedding.com



The Best In Top Quality Marine Products. Since 1917.

15242 Transistor Lane, Huntington Bch, CA 92649
 800.433.0101 www.bainbridgeintcatalogs.com

Directions

BY WATER

FERRY: From San Francisco take the Alameda/Oakland Ferry from Pier 41 or the Ferry Building (Pier 1). Get off in Oakland at Jack London Square. Walk two minutes south along the waterfront. (510) 522-2300.

BOAT: Contact Almar Marinas at (510) 834-4591.

BY LAND

BART: Take BART to the 12th St. station in Oakland; from there take an AC Transit bus down Broadway to Jack London Square. (510) 465-2278.



AMTRAK: The Capitol Corridor is offering two-for-one tickets to the C.L. Dellums rail station at 2nd and Alice, directly across from Jack London Square. Take the pedestrian overcrossing to get to the Square. (800) 872-7245.

SOUTH ON HWY 880 FROM SF/NORTH BAY: Take the Broadway/Alameda exit. At the end of the ramp turn right; the sign says Alameda. Turn right onto Martin Luther King Jr. Turn left onto 2nd Street.*

NORTH ON HWY 880 FROM SAN JOSE: Take the Broadway exit. At the end of the ramp turn left onto Broadway. Turn left on 2nd Street.*

WEST ON HWY 980 FROM WALNUT CREEK: Take the 12th Street exit. Go straight, turn left onto 5th Street, right onto Martin Luther King Jr., and left onto 2nd Street.*

*The parking garage is at 2nd and Harrison Streets.



To view a show floor plan, go to www.strictlysailpacific.com

SAILING

You Can Do It – Find Out How

SailSFBay.org



Gateway
to Sailing



Lessons • Schools
Junior Programs
Camps • Rentals

Parking



The parking garage is at 2nd and Harrison Streets.

To view a show floor plan, please go to www.strictlysailpacific.com

BAY AREA BOAT LOANS

A BETTER WAY TO FINANCE YOUR BOAT

Professional • Efficient • Specialized

Marine Financing Offered Through

INTERCOASTAL
Financial Group, LLC

RATES AS LOW AS 3.74% FIXED*



See us at
Debbie Betts
(510) 227-5797 Office
(510) 846-0578 Cell
dbetts@boatloans.net

www.bayareaboatloans.com

*Vessel and borrower restrictions apply. Subject to change.

LIFELINE[®] PREMIUM AGM BATTERIES



Crafted for quality in the U.S.A.



150 AMP
hour
group 30

The only AGM L-16 400 AMP hour
completely manufactured
in the USA.



LIFELINE BATTERIES

292 East Arrow Highway, San Dimas, CA 91773-3359

(800) 527-3224

www.lifelinebatteries.com

ADVERTISERS' INDEX

The Strictly Sail Pacific Boat Show Guide is brought to you by the following advertisers. Please support the businesses that made this publication possible.

AB Marine.....	41
ATN.....	45
Afterguard Sailing Academy	51
Almar Marinas	21
Bainbridge.....	52
Beneteau USA	9
BVI Yacht Charters	50
Catalina Yachts	4
Club Nautique.....	30
Coppercoat USA.....	45
Costa Baja Resort and Marina.....	31
Davis Instruments	26
Doyle Sails.....	15
Euro Marine Trading.....	55
Gig Harbor Boat Works.....	25
Hobie Cat.....	19
Hotel Coral and Marina	37
Hydrovane	27
Hylas Yachts.....	6-7
Intercoastal Financial Group	54
JK3 Nautical Enterprises.....	17
Jeanneau America	56
LaPaz Hotel	33
<i>Latitude 38</i> Baja Ha-Ha Beach Party.....	33
Lifeline Batteries	54
Marina Bay Yacht Harbor	22
Marina Cortez.....	36
Marina de La Paz	35
Marina El Cid.....	36
Marina Riviera Nayarit.....	39
Marina Vallarta.....	33
Maritime Institute.....	26
Mathiesen Marine	23
New England Ropes.....	24
Pantaenius Yacht Insurance	49
Pettit Paint.....	2.3
Ronstan Marine, Inc.	47
Sail California	11
SailSFBay.org.....	53
San Juan Sailing	50
Svendsen's Boat Works.....	29
Trident Funding.....	51
Twin Rivers Marine Insurance	45
Whitecaps Marine Outfitters	13
Wichard Sparcraft, Inc.	43
Yachtbedding.com.....	52

antal

Deck Hardware for Sailboats

Antal Winches



XT self-tailing models are available in aluminum, chrome-plated bronze and natural polished bronze. Available in racing, cruising, electric and hydraulic and come in one-, two- and three-speed options. A full range of winch handles are also available.

Antal Clutches



Antal's patented V-Cam is designed to reduce line compression without sacrificing holding capacity and features an ergonomic silver anodized aluminum handle. Available in single, double, triple and quadruple models for 8-10mm, 10-12mm or 12-14mm line. Full range of organizers also available.

EURO MARINE
Trading, Inc.

62 Halsey Street • Newport, RI 02840
Tel. 401-849-0060 or 800-222-7712

www.euromarinetrading.com

Your Dream is Closer than You Think



Jeanneau Yacht



Sun Odyssey



Deck Salon

Sun Fast 3200 **new 3600**
Sun Odyssey **new 349** 379 409 439 469 509
Deck Salon 41DS 44DS 50DS
Jeanneau Yachts 53 57 **new 64**

410.280.9400
info@jeanneau.com
Jeanneau.com

