

Latitude 38

VOLUME 450 December 2014

WE GO WHERE THE WIND BLOWS

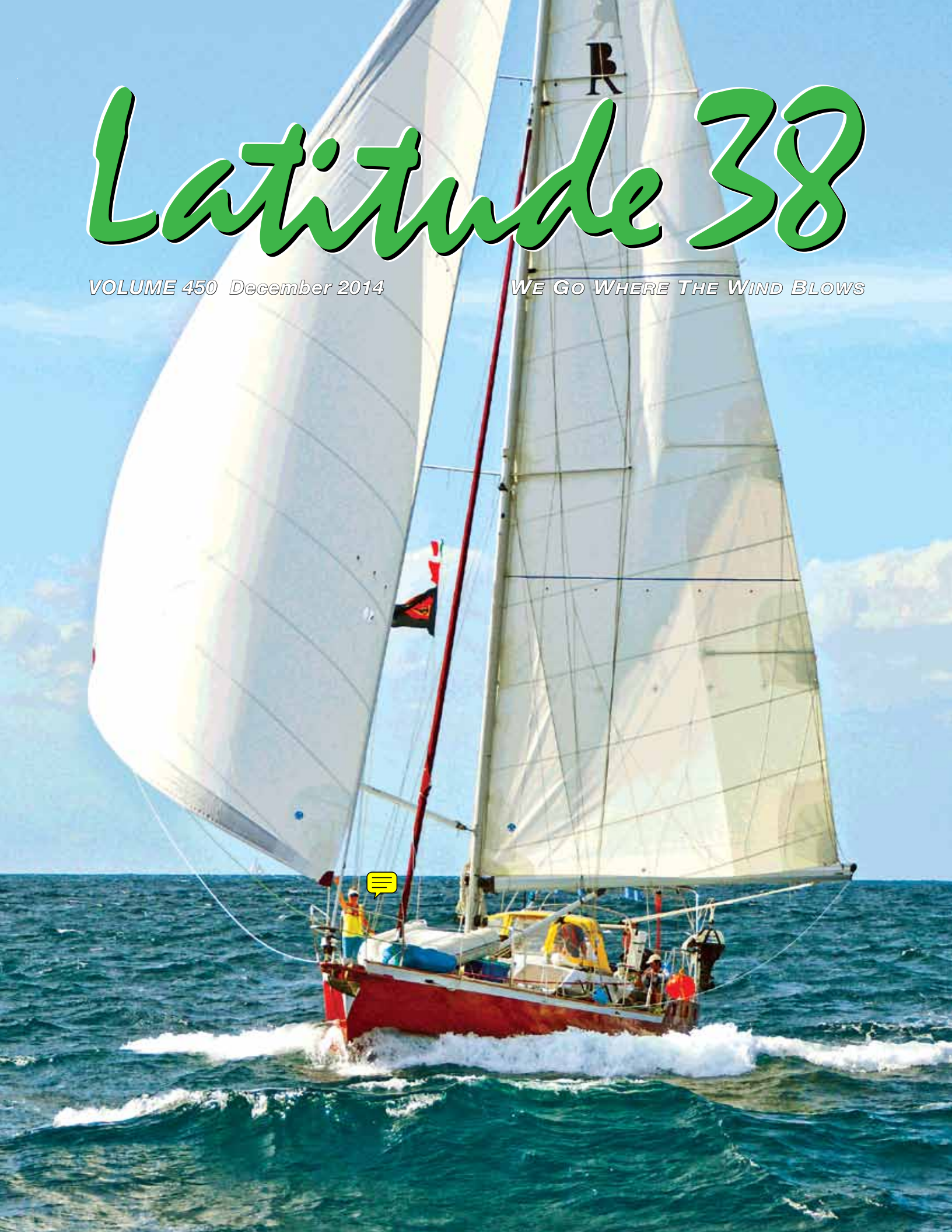

GRAND MARINA

WARM WISHES AND SEASON'S GREETINGS



FROM THE GRAND MARINA TEAM!

AT GRAND MARINA, WE BELIEVE IN HOSPITALITY, HONESTY AND GENUINE SERVICES.

These are just a few of the things you can take for Grand-ed when you stay with us.

Grand Marina: Where every day is a holiday!



510.865.1200

Leasing Office Open Daily
2099 Grand Street, Alameda, CA 94501

www.grandmarina.com

- ◆ Prime deep water double-fingered concrete slips from 30' to 100'.
 - ◆ Great Estuary location in the heart of beautiful Alameda Island.
 - ◆ Complete bathroom and shower facility, heated and tiled.
 - ◆ Free pump-out station open 24/7.
 - ◆ Full-service Marine Center and haul-out facility.
 - ◆ Free parking.
 - ◆ Free on-site WiFi.
- And much more...

Directory of Grand Marina Tenants

Blue Pelican Marine	119
Boat Yard at Grand Marina, The...	23
Marchal Sailmakers	116
MarineLube	103
New Era Yachts.....	128
Pacific Crest Canvas.....	24
Pacific Yacht Imports	16
Alameda Canvas and Coverings	
Alameda Marine Metal Fabrication	
UK Sailmakers	

Still Going Strong

★
Happy
Holidays
from all of us
at Pineapple Sails.
We'll be closed from
Thurs., Dec. 25, through
Sun., Jan. 4.

PHOTO JEFF KIRK



*Rainbow**

Rainbow, a Crowther cruising catamaran, has taken owner Cliff Shaw from San Francisco to Hawaii and back three times, to Cabo San Lucas and back in the 2010 Baja Ha-Ha, and to the Farallones and other coastal destinations, racking up over 18,000 nautical miles on her 2006 Pineapple Sails.

In 2012, *Rainbow* won the Multihull Division of the Singlehanded Transpac, then was sailed solo again to cruise the Hawaiian Islands in 2014.

In the 16 years Cliff has owned her, multihulls have shifted from lesser known to front page news, cruising and racing. *Rainbow* has proved a good cruiser and racer, swift and comfortable, for singlehanded sailing and with full crew. Her Pineapple sails have proved both durable and competitive.

Rainbow is being readied now for another long distance cruise with some upgrades and new gear, but she'll use the same 8-year-old Pineapple sails. Sails that are still going strong.

Monohull, multihull, racers, cruisers, big boat and small — in our 42 years in business, we've made sails for them all. Call us for a quote today.

YOUR DEALER FOR: Musto foul weather gear, Dubarry footwear, and Spinlock Deckwear

Sails in need of repair may be dropped off at West Marine in Oakland or Alameda
and at Inland Sailing Company in Rancho Cordova.

Like us on Facebook.



PINEAPPLE SAILS

*Powered by Pineapples

Phone (510) 522-2200

Fax (510) 522-7700

www.pineapplesails.com

2526 Blanding Ave., Alameda, California 94501

BOAT LOANS

from



Trident Funding

*"a fresh
approach
from people
you can trust"*

In Northern California call
JOAN BURLEIGH
(800) 690-7770

In Southern California call
JEFF LONG
(888) 883-8634

www.tridentfunding.com

Loans will be arranged or made pursuant to a
California Finance Lenders License #605 1871.

CONTENTS

subscriptions	6
calendar	8
letters	16
sightings	56
baja ha-ha recap	68
season champs, pt. II	80
reed interview	84
max ebb: sailing ted talks	90
the racing sheet	94
world of chartering	100
changes in latitudes	104
classy classifieds	120
brokerage	126
advertisers' index	127

Cover:

During the second leg of last month's Baja Ha-Ha rally, sailing conditions were excellent off the mid-Baja coast. Seen here, the Vancouver, BC-based Roberts V495 *Dream Catcher* surfs the swells en route to Bahia Santa Maria.

Photo by Lynn Ringseis

Copyright 2014 Latitude 38 Publishing, LLC

Latitude 38 welcomes editorial contributions in the form of stories, anecdotes, photographs – anything but poems, please; we gotta draw the line somewhere. Articles with the best chance at publication must 1) pertain to a West Coast or universal sailing audience, 2) be accompanied by a variety of pertinent, in-focus digital images (preferable) or color or black and white prints with identification of all boats, situations and people therein; and 3) be legible. These days, we prefer to receive both text and photos electronically, but if you send by mail, anything you want back must be accompanied by a self-addressed, stamped envelope. **Submissions not accompanied by an SASE will not be returned.** We also advise that you not send original photographs or negatives unless we specifically request them; copies will work just fine. Notification time varies with our workload, but generally runs four to six weeks. Please don't contact us before then by phone or mail. Send all submissions to editorial@latitude38.com, or mail to Latitude 38 editorial department, 15 Locust Ave., Mill Valley, CA 94941. For more specific information, request writers' guidelines from the above address or see www.latitude38.com/writers.html.

SELECT BROKERAGE



TARTAN 3400
Asking \$148,888



BENETEAU FIRST 25
Asking \$89,000

BENETEAU BROKERAGE

BENETEAU 473	2006	\$245,000
BENETEAU 423	2005	\$139,935
BENETEAU 423	2004	\$165,000
OCEANIS 411	1998	\$100,000
OCEANIS 37	2013	\$183,000
OCEANIS 31	2009	\$105,000
FIRST 42	1985	\$84,000
FIRST 35s5	1990	\$59,500
FIRST 25	2013	\$89,000
FIRST 20	2013	\$49,500

EXCLUSIVE BROKERAGE

ISLAND PACKET 485	2006	\$529,000
JEANNEAU 45 DS	2008	\$298,777
DUFOUR 44	2004	\$249,000
JEANNEAU 43 SO DS	2003	\$169,999
HUNTER 42 CC	2002	\$139,000
SANTA CRUZ 40	1983	\$79,000
ISLAND PACKET 380	2003	\$235,000
ISLAND PACKET 380	2000	\$220,000
BALTIC 38 DP	1983	\$113,900
TARTAN 3400	2007	\$148,888
DUFOUR GIB'SEA 32	2001	\$54,500

POWER BROKERAGE

MIKELSON 61 PH	2002	\$795,000
OFFSHORE 58 PH	1995	\$795,000
CAMARGUE 48	1988	\$199,888
GRAN TURISMO 44	2013	\$499,000
BAYLINER 3988	2001	\$144,500
BARRACUDA 9	2013	\$149,151

Need a Break from Tweeting, Blogging and High-Speed Living? Try our New Social Network – Gloating Glamour boating on a new Beneteau or Lagoon

Get away from the high speed pace of daily life and connect in real time aboard a beautiful new yacht with family and friends.

A day on the Bay is like a week on vacation – only there's no crowded airports, long lines or missed connections.

We take trades – so trade in some of your hectic lifestyle for some peace and relaxation this coming year.

Get away from it all in exquisite style and luxurious amenities – Five-Star living right outside your door.



OCEANIS 35
NEW MODEL
ARRIVES THIS MONTH

OCEANIS 41
NEW 2015 READY FOR
THE NEW YEAR



LAGOON 400
NEW MODEL
ARRIVES THIS MONTH



HAPPY HOLIDAYS FROM EVERYONE AT PASSAGE!



1220 Brickyard Cove Rd., Pt. Richmond, CA

p: 510-236-2633

f: 510-234-0118

www.passageyachts.com

Look for our
new branch office
in Jack London Sq.
January 2015

POWER & SAIL NEW BOAT SALES • BROKERAGE • CONCIERGE OWNER'S SERVICES • CHARTER PLACEMENT

Outboard Engine Owners:

WE UNDERSTAND



When an engine dies, there's no walking home – just costly repairs, lost vacation time, and lost revenues.

Don't find yourself in this boat. Regular maintenance prevents expensive repairs.

We are *your* experts for outboard diagnostics, repair, repower, sales and service.



- Factory-trained and certified techs
- Open six days a week
- New and used engines bought and sold
- One-year warranty on all work performed and used engine sales
- Three-year warranty on all new engines

MARINE OUTBOARD

since 1990

OUTBOARD SALES, SERVICE, REPAIR, PARTS

(415) 332-8020

Nissan
Tohatsu
Johnson
Evinrude



Honda
Mariner
Mercury
Yamaha

35 Libertyship Way • Sausalito, CA 94965

Conveniently located at Libertyship Marina

If we're not maintaining your outboard, you've missed the boat!

SUBSCRIPTIONS

YOU CAN ALSO GO TO www.latitude38.com TO PAY FOR YOUR SUBSCRIPTION ONLINE

eBooks email list. *Free!*

See www.latitude38.com to download the entire magazine for free! Our eBooks are in PDF format, easy to use with Adobe Reader, and also available in Issuu format.

Email: _____

Please allow 4-6 weeks to process changes/additions, plus delivery time.

Enclosed \$36 for one year Third Class Postage (Delivery time 2-3 weeks; Postal Service will not forward third class; make address changes with us in writing.)

Enclosed \$55 for one year First Class Postage (Delivery time 2-3 days.)

Third Class Renewal First Class Renewal (*current subs. only!*)

Gift Subscription *Card to read from:* _____

NOTE: Subscriptions going to correctional facilities, FPO/APO (military), Canada, and Mexico are first class only. Sorry, no other foreign subscriptions.

Name _____

Address _____

City _____ State _____ Zip _____

Phone: () _____ Email: _____

CREDIT CARD INFORMATION MASTERCARD VISA AMERICAN EXPRESS
Min. Charge \$12 Number: _____ Exp.: _____ CSV: _____

INDIVIDUAL ISSUE ORDERS Current issue = \$6 ea.

Back Issues = \$7 ea. MONTH/YEAR: _____

DISTRIBUTION

We have a marine-oriented business/yacht club in California which will distribute copies of *Latitude 38*. (Please fill out your name and address and mail it to the address below. Distribution will be supplied upon approval.)

Please send me further information for distribution outside California

Business Name _____ Type of Business _____

Address _____

City _____ State _____ Zip _____

County _____ Phone Number _____

Latitude 38

"we go where the wind blows"

Publisher/Exec. Editor Richard Spindler richard@latitude38.com
Associate Publisher John Arndt john@latitude38.com ext. 108
Managing Editor Andy Turpin andy@latitude38.com ext. 112
Racing Editor Christine Weaver chris@latitude38.com ext. 103
Contributing Editors John Riise, Paul Kamen, LaDonna Bubak
Special Events Donna Andre donna@latitude38.com
Advertising Sales John Arndt john@latitude38.com ext. 108
Advertising Sales Mike Zwiebach mikez@latitude38.com ext. 107
General Manager Colleen Young colleen@latitude38.com ext. 102
Production/Photos Annie Bates-Winship annie@latitude38.com ext. 106
Production/Classifieds Carrie Galbraith carrie@latitude38.com ext. 110
Bookkeeping Penny Clayton penny@latitude38.com ext. 101

Directions to our office press 4
Subscriptions press 1,4
Classifieds class@latitude38.com press 1,1
Distribution distribution@latitude38.com press 1,5
Editorial editorial@latitude38.com press 1,6
Calendar calendar@latitude38.com
Other email general@latitude38.com



www.latitude38.com
15 Locust Avenue, Mill Valley, CA 94941
Ph: (415) 383-8200 Fax: (415) 383-5816





Cityyachts



Greenline
The Hybrid.

San Francisco's Yacht Brokers
Since 1969

Northern California's exclusive agent



Islander 36
1981 • \$34,000



Alerion Express 28
2001 • \$74,500



33' Greenline Diesel/Electric 2015
Free fuel for 3 years – call for details.



32' Nordic Tug
2006 • \$219,000

ALSO FEATURING:

POWER

62' Service Ship, 1974.....	\$879,000
48' DeFever LRC/Trawler, 1980	\$149,500
44' Sea Ray 440 Express Bridge, 1997	\$149,900
43' Hatteras, 1979	\$85,000
41' Storebro SRC 400, 1990.....	\$129,000
40' Greenline, New 2015	Call for Pricing
39' Sea Ray SF Sedan, 1985/1991 refit.....	\$135,000
34' Californian LRC, 1982	\$48,000
33' Greenline diesel/electric, 2015.....	free fuel for 3 years!

32' Wasque, 1973.....	\$85,000
30' Mainship Pilot II, 2002	\$82,000
27' Boston Whaler Offshore Walkaround, 1992	\$69,000
SAIL	
44' Farr, 1989	\$148,500
44' Jeanneau, 1991	\$109,000
40' Passport, 1985	\$145,000
40' Beneteau, 2009	\$175,000
38' Cape George, 2000.....	\$162,500
37' Pacific Seacraft, 1980	\$109,000

10 MARINA BLVD., SAN FRANCISCO, CA 94123 • Toll Free: 877-444-5091 • 415-567-8880
FAX (415) 567-6725 • email: sales@citysf.com • website: www.citysf.com

PLEASE VISIT OUR FUEL DOCK AT GASHOUSE COVE MARINA • OPEN 7 DAYS A WEEK • 9AM TO 5PM

FREE Foul Weather Gear

to put under the tree of every new sailor on your list

We'll send you a beautiful gift certificate or you can stop in to pick up the foulies and class material to wrap up and put under the tree!



INCLUDED!
- For December ONLY -
a rugged set of West
Marine foul weather gear!!

Basic Cruising Skipper's Package

Total Package Value: \$3,300!

Package Includes:

- Basic Keelboat Class 
- Basic Cruising Class 
- Bay Cruising Destination Workshop
- US SAILING Membership
- Club Nautique Basic Membership Initiation*
- Rugged West Marine Foul Weather Gear

ONLY \$1,295!

* One year membership required. Offer expires 12/31/14.
Classes must be completed by 3/31/2014

Qualifies you to charter from our fleet of beautiful boats up to 35'!

Call Today!

Alameda 800-343-SAIL
Sausalito 800-559-CLUB

Club Nautique

www.clubnautique.net

CALENDAR

Non-Race

Dec. 1-5 — The 103-ft swift topsail ketch *Hawaiian Chieftain* is berthed at Old Sacramento's floating dock and open for public tours on Tues.-Fri., 4-5 p.m., and Sat.-Sun., 10 a.m.-1 p.m. \$3 donation. Info, www.historicalseaport.org.

Dec 3-8 — The 112-ft tall ship *Lady Washington* visits Morro Bay. Walk-on tours, \$3 donation; adventure sails, \$43. Schedule and info, www.historicalseaport.org.

Dec. 3-17 — San Diego's South Bay Sea Scouts meet at Chula Vista Marina aboard the schooner *Bill of Rights* on Wednesdays at 7 p.m. Sea Scouts is a Boy Scouts of America program for guys and gals ages 13-20. John, (619) 852-7811 or mossfish@gmail.com.

Dec. 3-17 — Wednesday Yachting Luncheon Series at St. Francis YC, 12-2 p.m. Enjoy lunch and a dynamic speaker each Wednesday for about \$25. All YCs' members welcome. More info under 'Events' tab at www.stfyc.com.

Dec. 6 — Sail under the full moon on a Saturday night.

Dec. 6 — Lighted Yacht Parade on the Oakland/Alameda Estuary, 5:30 p.m., benefitting the Oakland Firefighters' Random Acts of Kindness and the Alameda County Food Bank. 'Light Up the Night' is this year's theme. Sponsored by EYC & OYC. Info, www.lightedyachtparade.com.

Dec. 6 — Lighted Boat Parade in Santa Cruz, 5:30 p.m. SCYC, www.scyc.org.

Dec. 6 — Lighted Boat Parade in Stockton, 5 p.m. SSC, www.stocktonsc.org.

Dec. 6, Jan. 3

— Chantey Sing aboard *Balclutha* at Hyde Street Pier in SF, 8 p.m.-midnight. Dress warmly and bring your own mug. Free, but RSVP to Peter, (415) 561-7171.

Dec. 7 — Lighted Boat Parade on Monterey Bay, 5:30 p.m. MPYC, www.mpyc.org.

Dec. 7-28 — Veterans' Sail, 10 a.m., and Sunday Keelboat Sail, 12 noon, every Sunday with BAADS at South Beach Harbor, SF. Free. Info, (415) 281-0212 or www.baads.org.

Dec. 10 — Shop our online chandlery to find the perfect gifts for the sailors on your list. Place



SHIRLEY VAUGHAN

Find festive fun at a lighted boat parade near you.

your order today to ensure delivery in time for Christmas. See www.latitude38.com/chandlery/chandlerycover.html.

Dec. 12 — Decorated Boat Parade on the San Francisco Cityfront, 6 p.m. StFYC, (415) 563-6363 or www.stfyc.com.

Dec. 13 — Lighted Boat Parade in Petaluma, from the ma-

FARALLONE YACHT SALES



Ranger 31 Flybridge

Catalina Yachts



GLACIER BAY
Classic Yachting. Smooth Rides.



Surprise someone special with a new Ranger 31 Flybridge or Sedan Trailerable Tug. We'll even gift wrap! Stop by today and discover the Farallone advantage. Whether you're looking for a new Catalina, Ranger Tug, Glacier Bay PowerCat or quality pre-owned yacht, we can finalize *your* dream of owning your own boat! www.faralloneyachts.com

OPEN BOAT WEEKEND DECEMBER 13-14! • S.F. BOAT SHOW - JANUARY 22-25



1994 Catalina 42 \$113,000



2015 Catalina 445 Call for price



2015 Catalina 385 Call for price



1999 Beneteau 36.1 \$84,500



1973 C&C Custom 43 \$225,000



2005 Catalina 440 \$289,000

New Catalina Yachts at Our Docks

- 45' Catalina 445, 2015 **ARRIVING THIS MONTH!**
- 38' Catalina 385, 2015 **JUST ARRIVED!**

Pre-Owned Catalina Yachts at Our Docks

- 44' Catalina 440, 2005 **COMING SOON** \$289,000
- 42' Catalina, 1994 **NEW LISTING** 113,000
- 38' Catalina 380, 1999 **NEW LISTING** 85,000
- 38' Catalina 380, 1997 **REDUCED!** 87,900
- 32' Catalina 320, 2000, not at our dock 52,500

We need Catalina listings. First month's berthing is FREE!

Pre-Owned Sailing Yachts

- 44' Norseman 447, 1984 **REDUCED!** 139,000
- 43' C&C, 1973 225,000
- 40' C&C 121, 1999 **REDUCED!** 98,127
- 40' Wilderness, 1983 **REDUCED!** 36,000
- 39' Cal, 1989, cruise equipped 89,900
- 39' Yorktown, 1980 **JUST ARRIVED!**
- 38' CT, 1982 **NEW LISTING** 60,000
- 36' Beneteau 36.1, 1999 **NEW LISTING** 84,500
- 36' Pearson 36-2, 1986 **NEW LISTING** 59,500
- 29.5' Hunter, 1995 **NEW LISTING** 29,000
- 28' Hunter, 1986 15,900

New Ranger Tugs (base price)

- 31' Ranger Tug Sedan, 2015 269,937
- 31' Ranger Flybridge, 2014 279,937
- 27' Ranger Tug, 2015 159,937
- 25' Ranger Tug SC, 2014 129,937

Pre-Owned Ranger Tugs

- 29' Ranger, 2011 **JUST ARRIVED** 209,000
- 25' Ranger Tug, 2008 **NEW LISTING** 109,000

New Powercats

- Glacier Bay 2870 \$179,137

Pre-Owned Power Yachts

- Stephens 70 Classic Motor Yacht, 1966 1,100,000
- Freedom Yachts Legacy 40, 1996 **REDUCED** 199,500

Pre-Owned Fishing Boat

- Osprey 26, 1999 **REDUCED!** 56,000



FARALLONE

1070 Marina Village Parkway
Alameda, CA 94501
(510) 523-6730

SAN FRANCISCO MARINA SMALL CRAFT HARBOR

Set your course a full 180 degrees from the world of deadlines and commitment, into the world-renowned San Francisco Marina Small Craft Harbor, host of the 2013 Americas Cup. Discover a boater's paradise and why so many boaters choose the San Francisco Marina Small Craft Harbor as their home port of call. From the first-time owner to the experienced Captain, there is a wealth of mariner knowledge on our state-of-the-art floating docks.



There is Something For Everyone at Our Prestigious Marina

Stunning 35-acre, 725-slip marina, featuring all floating docks, 50% new concrete docks

725 berths, accommodating vessels up to 90 feet

Electrical service from 30amp/125 volt to 50amp 125/250 volt

Free water at every berth

Sanitary pump-out service available, free to all

Shower and restroom facilities, open 24/7

The Marina Office is open daily, monitoring VHF Channel 16 & 68

Automobile parking available near the marina

Marine fuel station, featuring diesel and gasoline

Beautiful view of the Golden Gate bridge, accessible by our signature Bay Trail

Immediate Access to the San Francisco Bay World Class Sailing

Shopping, Restaurants and Nightclubs, all within walking distance of the marina

World Renowned Marina Green Park and Fitness Center

Two World-class Yacht Clubs



To reserve a transient berth or for information regarding available long term berths, please contact the Marina Office.

3950 Scott Street | San Francisco, CA 94123
415.831.6322 | www.sfrecrepark.org

CALENDAR

rina to the Petaluma River turning basin. 6 p.m. Info, www.visitpetaluma.com.

Dec. 13 — Sausalito Lighted Boat Parade, 5 p.m. SYC, (415) 332-7400 or www.sausalitoyachtclub.org.

Dec. 13 — San Rafael Lighted Boat Parade, with more than 100 decorated yachts, starting at 6 p.m. Info, (415) 526-7577 or www.lightedboatparade.org.

Dec. 13 — Old Time Maritime Christmas, Hyde Street Pier, San Francisco, 6-9 p.m. A Costumed Living History event. Admission to the Pier is free; vessel admission is \$5, free for kids 15 & under. Info, (415) 447-5000 or www.nps.gov/safri.

Dec. 14 — West Coast Multihulls Bay Regatta & Parade of Lights Party, Sunroad Marina, San Diego, 11 a.m.-8:30 p.m. Pursuit race & raft-up for multihulls, poolside BBQ & model boat racing, followed by parade viewing. Mike, (619) 517-5630 or www.westcoastmultihulls.com.

Dec. 14, 20-21, 27-28, Jan. 3-4, 10-11 — Three-hour Battle Sails aboard *Lady Washington* and *Hawaiian Chieftain* in Long Beach or San Pedro, featuring booming cannons, close-quarters maneuvers, and a taste of 18th century maritime life aboard tall ships. \$43-\$63. Schedule and tickets, www.historicalseaport.org.

Dec. 20 — Laser Clinic, King Harbor Youth Foundation, Redondo Beach, 11 a.m.-4 p.m. \$40. Info, www.khyf.org/laser-clinics.html.

Dec. 1984 — From the Letter titled 'No Luck Yet' back in the pre-Internet dark ages, with some advice that still holds true:

I'd appreciate it if you could be more explicit on how to make a new connection in Baja this winter. There's got to be a better way than flying down to Loreto or La Paz and standing on the dock with my harness and canvas hat in hand, and a silly look on my face.

I'm on your Crew List, attended the Party, but no luck yet.
S.H.

Sunnyvale

S.H. — This is as explicit as we can get: If it were us, and we were a reasonably good sailor who got along with most people, we indeed would fly down to either La Paz or Cabo (not Loreto), get an inexpensive hotel room, and try to make a connection. It's a nothing risked, nothing gained proposition. There are popular VHF nets in both La Paz and Cabo to get your request for a berth out to the fleet, and there are bulletin boards. Certainly it's a risk, but the available berths — and there usually are quite a few — go to the pretty young women and those who are Johnny-on-the-spot. Since you can't be a pretty young woman, be the next best thing. And what's the worst that can happen to you? You'll spend a couple of days in Cabo or La Paz, both fine towns.

If you want to be a little more conservative in your approach, you can try further through the Classy Classifieds.

Jan. 7-11 — Portland Boat Show at the Portland Expo Center. Info, www.otshows.com.

Jan. 14 — Racing Rules of Sailing Seminar Series, Long Beach YC, 7 p.m. This one covers the startline, upwind leg, and windward mark rounding. Info, www.lbyc.org.

Jan. 22-25 — Progressive San Francisco Boat Show, Pier 48 & McCovey Cove. Info, www.sfboatshow.com.

Jan. 22-25 — San Diego Sunroad Marina Boat Show. Info, www.bigbayboatshow.com.

Jan. 23-Feb. 1 — Seattle Boat Show Indoors + Afloat, at CenturyLink Field and on South Lake Union. Info, www.seattleboatshow.com.



Cruising Yachts



**WISHING YOU A HAPPY & SAFE HOLIDAY SEASON.
MAY ALL YOUR BOATING DREAMS COME TRUE!
FROM THE CREW AT CRUISING YACHTS**

NEW 2015 Model - In Stock!



New Jeanneau 41DS

Model Year-End Closeout



New 2014 Hunter 33

Dealer Demo - Never Titled



2012 Hunter 50 AC



'02 Beneteau 473 \$249,900



'06 Jeanneau 42DS \$198,000



'04 Tartan 4100 \$294,950



'99 Catalina 400 \$159,000



'00 Catalina 400 \$173,500



'04 Catalina 400 \$180,000



'09 Catalina 375 - \$189,000



'05 Catalina 350 \$125,000



'04 Hunter 33 \$74,900



'04 Hunter 33 \$69,500



'95 Pac. Seacraft 32 \$101,500



'89 Catalina 34 \$42,500

1983 Lancer M/S 70 \$595K

2010 Jeanneau 57 \$699K

2009 Jeanneau 54DS \$479K

2008 Jeanneau 54DS \$499K

2009 Hunter 49 \$349K

2004 Beneteau 473 \$229K

2007 Jeanneau 42i \$197K

1983 Tayana 42 \$106K

2007 Catalina 42 \$199K

1996 Nautor Swan 40 \$299K

1998 Pac. Seacraft 40 \$267K

1980 CAL 39 MKII \$65K

2010 Hunter 39 \$185K

1984 Catalina 36 \$38K

1983 Catalina 36 \$39K

2006 Hunter 36 \$115K

2009 Hunter 36 \$120K

2013 Hunter 33 \$167K

2009 Jeanneau 3200 \$175K

Alameda Yacht Sales Office

1070 Marina Village Pkwy, #101A
Alameda, CA 94501

WWW.CRUIISINGYACHTS.NET

Alameda: (510) 521-1327
Marina del Rey: (310) 821-8300

San Diego: (619) 681-0633
Newport Beach: (949) 650-7245

Gori propeller

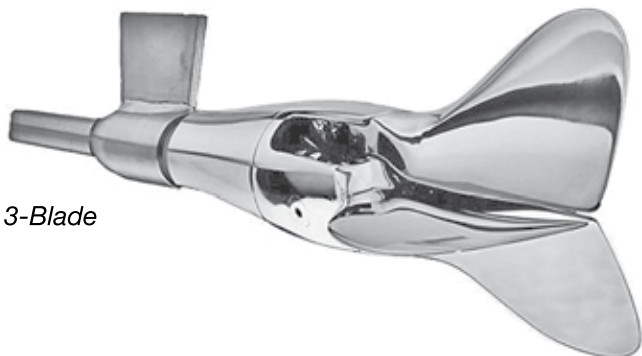

3-Blade

- For shafts and saildrives
- Both 2 & 3 blade available
- Lowest drag when sailing
- The champions choice



747 Aquidneck Ave.
Middletown, RI 02842

401-847-7960

Fax: 401-849-0631

sales@ab-marine.com

www.ab-marine.com

CALL US TODAY!

800-801-8922

SHAFT SHARK

*The best rope,
line and debris
cutter there is!*



401-847-7960

sales@ab-marine.com

www.ab-marine.com

Fix & Color Fiberglass in Seconds



sales@ab-marine.com



sales@ab-west.com

CALENDAR

Racing

Dec. 6 — Fall Series Races. SSC, www.stocktonsc.org.

Dec. 6-7 — Opti Winter Series. StFYC, (415) 563-6363 or www.stfyc.com.

Dec. 13 — Santana 22 Team Racing in Santa Cruz. SCYC, www.scyc.org.

Dec. 13 — Chowder Cup. ElkYC, www.elkhornyc.com.

Dec. 14 — West Coast Multihulls Bay Regatta, San Diego. Pursuit race for multihulls. See Non-Race for more info.

Dec. 16-18 — Banderas Bay Blast & Pirates for Pupils. Three days of fun racing for cruisers intended to welcome new cruisers to Banderas Bay. The Pirates for Pupils downwind run helps local schools. Dressing like a pirate is highly recommended! Info, www.vallartayachtclub.org.

Dec. 28 — Christmas Race. MPYC, www.mpyc.org.

Jan. 1 — Brrrr Rabbit. CPYC, (650) 347-6730 or www.cpyc.com.

Jan. 18-23 — Quantum Key West Race Week, an international midwinter classic. Info, www.premiere-racing.com.

Jan. 31 — Three Bridge Fiasco. This aptly-named pursuit race, the most popular on the Bay, is the first SSS event of the season. Info, www.sfbaysss.org.

Midwinter Regattas

BAY VIEW BC — Midwinter Madness: 12/13, 1/10, 2/14, 3/14. Terry, (408) 210-0517 or www.bayviewboatclub.org.

BERKELEY YC — Midwinters: 12/13-14, 1/10-11, 2/14-15. Bobbi, (925) 939-9885 or www.berkeleyyc.org.

BERKELEY YC — Chowder Races: Sundays through the end of March except when it conflicts with above. Paul, (510) 540-7968 or www.berkeleyyc.org.

CAL SAILING CLUB — Year-round Sunday morning dinghy races, conditions permitting, intraclub only, typically in Laser Bahias and JY15s. Info, www.cal-sailing.org.

CORINTHIAN YC — Midwinters: 1/17-18, 2/21-22. Info, (415) 435-4771 or www.cyc.org.

COYOTE POINT YC — Winter Beercans: 1/11, 1/15, 2/8, 2/22, 3/8, 3/22. Info, (650) 347-6730 or www.cpyc.com.

ENCINAL YC — Jack Frost Series: 1/10, 2/21, 3/14. Info, (510) 522-3272 or www.encinal.org.

GOLDEN GATE YC — Manuel Fagundes Seaweed Soup Series: 12/6, 1/3, 2/7, 3/7. Info, (415) 346-2628 or www.ggyc.com.

ISLAND YC — Island Days on the Estuary: 12/14, 1/11, 2/8, 3/8. John, (510) 521-2980 or www.iyc.org.

LAKE MERRITT SAILING CLUB — Midwinters: 12/13, 1/11, 2/14, 3/8; this year at Oakland's Jack London Aquatic Center on the Estuary instead of on the lake, due to construction. Mark, (925) 245-0287.

MONTEREY PENINSULA YC — Perry Cup/Midwinters: 12/6, 1/3, 2/7. Info, www.mpyc.org.

OAKLAND YC — Sunday Brunch Series: 1/4, 1/18, 2/1, 2/15, 3/1. Info, www.oaklandyachtclub.net.

REGATTAPRO — Winter One Design: 12/13, 1/10, 2/7. Jeff, (415) 595-8364 or www.regattapro.com.

RICHMOND YC — Small Boat Midwinters: 12/7, 1/4, 2/1, 3/1. Optis & El Toro Green Fleet: 12/6, 1/31, 2/28. Info, www.richmondyc.org.

RICHMOND YC — Laser Sundays: 12/14, 12/21, 1/11, 1/18, 1/25, 2/8, 2/15, 2/22, 3/15, 3/22, 3/29. Info, <http://rycsunday.myfleet.org>.

SANTA CRUZ YC — Midwinters: 12/20, 1/17, 2/21, 3/21. Info, (831) 425-0690 or www.scyc.org.

SANTA ROSA SC — Spring Lake Winter Series: 12/20, 1/24, 2/21, 3/21. Info, www.santarosasailingclub.org.

THE FINEST SAILS BEGIN WITH THE BEST SAILCLOTH

Get ready for
spring sailing –
**WINTER
DISCOUNTS
NOW IN
EFFECT**

Our patented woven Vectran® sailcloth performs like the laminates with the durability of Dacron®, especially in roller furling applications. In fact, Vectran® is lighter, lower stretch, and retains its shape over a longer life than any sailcloth we've ever offered to cruising sailors. That's because Hood Vectran® is woven, not laminated to Mylar® film. And you can be sure that each sail we roll out is built by hand, with the same care and craftsmanship that has been the Hood hallmark for 50 years. To discuss your sailcloth needs – whether our state-of-the-art Vectran® or our soft, tight-weave Dacron® – give us a call today.

HOOD Sails & Service

HOOD New Sails

HOOD Sail Repairs

HOOD Furling Conversions

HOOD Free Pickup & Delivery



SAILMAKERS

Chesapeake

*Jim Fair's Outbound 46
with Hood Vectran
Full Batten Mainsail,
140% Genoa, and
Solent Jib*

PHOTO COURTESY
SWIFTSURE YACHTS
www.OutboundYachts.com



HOOD SAILMAKERS 465 Coloma Street, Sausalito, CA 94965
Call Robin Sodaro (800) 883-7245 (415) 332-4104 Fax (415) 332-0943
www.hood-sails.com hoodsails@aol.co

CALENDAR

SAUSALITO YC — Sunday Midwinters: 12/7, 1/4, 2/1, 3/1. Info, www.sausalitoyachtclub.org or race@sausalitoyachtclub.org.

SEQUOIA YC — Winter Series: 12/13, 1/3, 2/7, 3/14. Redwood Cup pursuit race series: 12/20, 1/10, 2/21, 3/7. Info, www.sequoiayc.org.

SOUTH BEACH YC — Island Fever Midwinters: 12/20, 1/17, 2/21, 3/21. Janelle, (650) 303-8236 or www.southbeachyc.org.

TIBURON YC — Midwinters: 1/10, 2/7, 3/7. Info, race@tyc.org or www.tyc.org.

VALLEJO YC — Tiny Robbins Midwinters: 12/6, 1/3, 2/7, 3/7. Info, (707) 643-1254 or www.vyc.org.

Please send your calendar items by the 10th of the month to calendar@latitude38.com. If you're totally old-school, mail them to *Latitude 38* (Attn: Calendar), 15 Locust Avenue, Mill Valley, CA, 94941, or fax them to us at (415) 383-5816. But please, no phone-ins! Calendar listings are for marine-related events that are either free or don't cost much to attend. The Calendar is not meant to support commercial enterprises.

December Weekend Tides

date/day	time/ht. LOW	time/ht. HIGH	time/ht. LOW	time/ht. HIGH
12/06Sat	0426/2.4	1036/6.5	1722/-1.0	
		LOW	HIGH	LOW
12/07Sun	0036/5.0	0512/2.6	1115/6.3	1801/-0.9
12/13Sat	0451/5.0	1047/2.5	1556/4.1	2215/1.2
12/14Sun	0532/5.2	1152/2.2	1711/3.8	2306/1.5
	LOW	HIGH	LOW	HIGH
12/20Sat	0313/2.6	0931/6.5	1618/-0.8	2328/4.7
12/21Sun	0358/2.6	1013/6.7	1658/-1.1	
	HIGH	LOW	HIGH	LOW
12/24Wed	0138/5.3	0626/2.5	1234/6.4	1909/-1.0
12/25Thu	0223/5.4	0725/2.4	1328/6.0	1956/-0.7
12/27Sat	0358/5.8	0945/1.9	1539/4.8	2140/0.4
12/28Sun	0448/5.9	1102/1.5	1700/4.4	2238/1.0
	LOW	HIGH	LOW	HIGH
12/31Wed	0042/2.0	0722/6.4	1418/0.0	2106/4.4

December Weekend Currents

date/day	slack	max	slack	max
12/06Sat	0117	0334/2.5E	0649	0937/3.0F
	1227	1541/5.1E	1942	2248/4.0F
12/07Sun	0204	0418/2.4E	0735	1020/2.8F
	1309	1624/5.0E	2025	2330/3.9F
12/13Sat	0003	0307/2.7F	0631	0856/2.4E
	1259	1522/1.6F	1811	2102/2.8E
12/14Sun	0050	0354/2.6F	0714	0948/2.6E
	1359	1627/1.7F	1919	2156/2.5E
12/20Sat	0013	0223/2.3E	0532	0829/2.9F
	1120	1439/5.1E	1838	2137/3.8F
12/21Sun	0101	0311/2.5E	0617	0913/3.0F
	1202	1524/5.4E	1920	2220/4.1F
12/24Wed	0320	0536/2.9E	0847	1139/2.9F
	1426	1747/5.2E	2136	
12/25Thu		0038/4.1F	0407	0627/3.0E
	0947	1235/2.8F	1523	1839/4.8E
	2225			
12/27Sat		0220/3.7F	0542	0817/3.3E
	1204	1442/2.6F	1739	2030/3.6E
12/28Sun	0011	0315/3.5F	0632	0916/3.6E
	1314	1556/2.6F	1854	2131/3.1E
12/31Wed	0307	0607/3.0F	0903	1217/4.4E
	1620	1926/3.4F	2226	

Give the Gift of DIY this Season!

'Tis the season for tools and Sailrite has you covered! The Sailrite Ultrafeed Sewing Machines, the Edge Hotknife and the Pres-N-Snap tool all make great gifts for the DIYer in your life.

Find more gift ideas at www.sailrite.com or call 800.348.2769

SAIL California



ALERION YACHTS



Also representing Jeanneau & Leopard in partnership with Cruising Yachts

Happy Holidays from the Crew at Sail California



'90 Santa Cruz 70 \$385,000



'94 Schooner 66 \$275,000



'86 Custom 52 \$99,000



'04 Santa Cruz 53 \$649,000



'04 Multi-hull 70 \$2,250,000



'05 Open 60 \$580,000



'01 J Boats J/42 \$239,000



'06 Alerion 38 \$249,000



'02 Custom 50 \$449,000



'07 J Boats J/124 \$229,000



'03 Reichel Pugh 44 \$274,900



'05 J Boats J/133 \$299,000



'12 Beneteau F. 40 \$179,000



'90 Hunter Legend 40 \$60,000



'04 J Boats J/109 \$169,900



'02 J Boats J/105 \$89,000

- 43' J Boats J/133 '05 \$299,000
- 43' J Boats J/133 '06 \$350,000
- 41' J Boats J/124 '06 \$220,000
- 40' J Boats J/120 '00 \$169,500
- 38' McConaghy '12 PENDING
- 36' J Boats J/36 '82 \$45,000
- 35' J Boats J/35 '93 \$44,900
- 35' J Boats J/105 '92 \$65,000
- 35' J Boats J/105 '01 \$78,000



'03 Open 50 \$195,000



'89 Nova 36 \$69,000



43' Riviera Conv. '97 \$249,000

SAIL CALIFORNIA

1070 Marina Village Pkwy, #108
Alameda, CA 94501

Alameda (510) 523-8500
San Fran. (415) 867-8056
So. Calif. (562) 335-7969

Visit our website at
www.SailCal.com

Pacific Yacht Imports



DON BROOKE 80, '81 \$375,000



TAYANA 55, '83 \$200,000



TAYANA 48 DS, '08 \$419,000



CATALINA 470, '06 \$309,000



SLOCUM 43, '83 \$159,000



X-YACHTS 43, '04 \$275,000



NAUTICAT 43 KETCH, '84 \$189,000



SERENDIPITY 43, '82 \$124,900



HUNTER 410, '00 \$113,900



TARTAN 41, '75 \$33,000



CANADIAN SAILCRAFT 40, '87 \$69,900



SWIFT 40 CC KETCH, '79 \$65,000



CATALINA 380, '01 \$135,500



HUNTER 310, '99 \$41,500

www.pacificyachtimports.net

Grand Marina • 2051 Grand St., Alameda, CA 94501
Tel (510) 865-2541 • tayana@mindspring.com

LETTERS

↑↓WHAT HAPPENED TO THE GOOD GUYS?

I have long thought of the Coast Guard as the 'Good Guys', who protect and rescue mariners. But recent events have made me wonder whose side they are on.

During the most recent Fleet Week, the Navy docked a destroyer next to the Pier 39 Marina. The vessel protruded some 50 feet past the end of the pier, and about that far from the entrance to the harbor. Despite this close proximity, they attempted to establish a 500-yard buffer zone, and two Coast Guard gunboats were determined to maintain it.

After my normally jovial dock neighbor, who was quite shaken, asked if I'd ever looked down the barrel of a Coast Guard machine gun, and after watching the Coast Guard hassle every boat that went by, I decided that I wouldn't go sailing until the Fleet Week weekend was over.

Unfortunately, the destroyer and Coast Guard gunboats were still there when I took some friends sailing on Monday afternoon. My guests convinced me to 'run the gauntlet', so I did. Sure enough, the Coasties approached as we headed out. They seemed friendly enough, so I told them where we were going, hoping they would remember us when we returned. We had no such luck.

Upon our return, I tacked out from Pier 27, pointed in the general direction of Richmond, a course which would have given the destroyer a wide berth. But that wasn't enough for

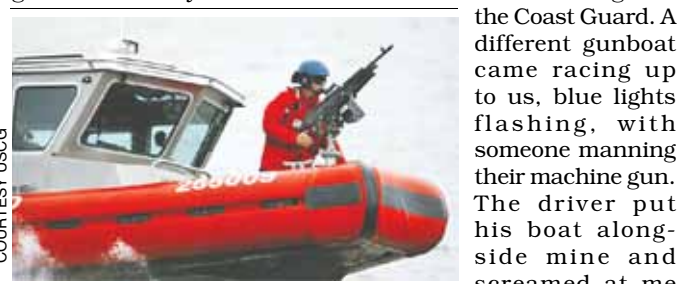

COURTESY USCG

the Coast Guard. A different gunboat came racing up to us, blue lights flashing, with someone manning their machine gun. The driver put his boat alongside mine and screamed at me to "head straight out." I explained

Having an automatic weapon pointed at you during a daysail is unnerving.

to him that I was returning to my berth at Pier 39, there was strong wind and a nasty ebb, we weren't wearing foul weather gear, and he was putting my boat and crew in peril. He was not swayed as he used his boat to force me to alter course. He remained alongside until I was well past Pier 39, and only then allowed me to tack. The only consolation I got was watching his crew get tossed about as they, like us, were beam to the heavy chop.

I could understand getting run off if I sailed too close to a Navy ship docked at a base, but they came and docked next to a marina, and then claimed a buffer that extended well past the entrance.

Had these been Navy gunboats, I could almost accept it, but I thought the Coasties were looking out for us. Their overly aggressive and threatening manner has left a bad taste in my mouth.

On a lighter note, thanks for the great cover, which I assume is Liz Clark of the Cal 40 *Swell*. Her stories are some of the most enjoyable to ever to grace the pages of *Latitude 38*, and she is an inspiration. I look forward to her first book.

Tim Donnelly
Chewink, Golden Gate sloop
Pier 39

Tim — We understand and sympathize completely with the frustration you feel. But you have to put yourselves in the shoes of the Coast Guard brass and the crews on the Coast Guard



**SVENDSEN'S
BOAT WORKS**

SEASON'S GREETINGS

from
Svendensen's



FREE rig inspection with a Svendensen's bottom job.

Svendensen's Boat Works extends our sincere thanks and good wishes to all of our many customers and friends around the world.

What's on your Christmas list?

Give us a call or email

Offer valid through 1-31-15

www.svendensens.com

1851 Clement Avenue, in the Alameda Marina

Call 510-522-2886 to learn more!

Boat Yard	x10	Metal Works	x40
Commercial Accounts	x20	Rig Shop	x50
Marine Store	x30	info@svendensens.com	

SPAULDING WOODEN BOAT CENTER



Happy
Holidays



From All of Us!!

The oldest boatyard in Sausalito!

AFFORDABLE QUALITY

We haul boats up to 42 feet long
and 24,000 lbs.

WOOD-FIBERGLASS-METAL



Lofting at our
Adult Boatbuilding Class.

**Still time to schedule
your winter projects**

ASK ABOUT OUR WINTER RATES!

(415) 332-3721

boatworks@spauldingcenter.org

FOOT OF GATE FIVE RD. SAUSALITO, CA 94965

WWW.SPAULDINGCENTER.ORG

LETTERS

boats. Homeland Security, which now runs the Coast Guard, has established rules for buffer zones around naval vessels and has charged the Coast Guard with enforcing the rules. The Coast Guard honchos have passed these orders down to the crews of the boats on the water. If you were any one of these people along the chain of command and took the initiative of being cavalier about the enforcement of buffer zones, at the very least you'd be up for disobeying orders, and at the very worst — as unlikely as it might be — your laxity might contribute to a successful terrorist attack on a Navy vessel. It's sort of like all of us having to put up with the aggravation of having to go through TSA if we want to fly — an unpleasant facet of modern life. The Coasties aren't the bad guys in this scheme, they are merely following orders. Your beef is with Homeland Security.

↑↓ SET A COURSE FOR A SAN FRANCISCO BAY RECORD

I read the November 14 *'Lectronic* in which *Latitude* suggested that Northern California sailing could be livened up with an event similar to the Mt. Gay Around Jamestown Record competition on Rhode Island's Narragansett Bay. For those who missed the story in *'Lectronic*, here's a summary of that competition:

1) It's 18 miles around Conanicut Island, which is in the middle of Narragansett Bay. 2) Record attempts can be made



The GC32 'Argo' made it around Conanicut Island in under an hour.

at any time on any day between Memorial Day and Labor Day. 3) A Challenger's starting time must be identified at 5 p.m. the day before a record attempt. 4) Boats may attempt records in one of three classes: Keelboat, All Sailing Craft Under 32 feet, and Multihulls. 4) Skippers who establish new records win their weight in Mt. Gay Rum. 5) Entry fees are \$50 to \$100, depending on the boat size.

Latitude asked for the best course for such a record on San Francisco Bay. My suggestion would be the Golden Gate YC, Red Rock, Treasure Island, and back to the Golden Gate YC.

Chris Boome
Burlingame



The proposed course for the 'Latitude 38 San Francisco Bay Record' is about 21 miles.

Chris — Let's consider what your proposed 'San Francisco Bay Record' course would likely entail: Brisk downwind sailing right after the start. Check. Having to deal with lighter and more fickle winds in the lee of Angel Island and the Tiburon Peninsula all the way to Red Rock. Check. A likely screaming reach across the bottom of the Bay to Treasure Island. Check. Having to negotiate the difficult lee of Yerba Buena. Check. And finally, a beat up the Cityfront to the Golden Gate YC finish line. Check.

It's essentially the Three-Bridge Fiasco course, which is a great one. But a proposed San Francisco Bay Record course



INFO@JK3YACHTS.COM

WWW.JK3YACHTS.COM



65' J/Boats J/65 2006
\$1,499,000 Contact: Jeff Brown



53' J/Boats J/160 1997
\$619,000 Contact: Rick Boyce



50' HANSE 505 2014
\$549,000 Contact: Jack Lennox



49' C Burns Schooner 2007
\$635k Contact: Alan Weaver



PRICED REDUCED
42' Bruckman/Zurn 2006
\$389k Contact: Kenyon Martin



41' Island Packet SP Cruiser 2007
\$417,500 Contact: Alan Weaver



Loaded - Nicest 124
40' J/Boat J/124 2007
\$279k Contact: Kenyon Martin



38' SABRE 386 2005
\$239,900 Contact: Jack Lennox



38' SABRE 386 2004
\$259,000 Contact: Alan Weaver



PRICED REDUCED
36' J/111 2010
\$275,000 Contact: Jeff Brown



New Listing - Clean
38' True North 38 2003
\$219,500 Contact: Kenyon Martin



36' Doral Boca Grande 2005
\$118,000 Contact: Alan Weaver



30' Raider 9m RIB w/ 300Hp 2009
Contact: Jack Lennox

- ADDL USED SAIL.....**
- 1995 56' Perry Custom \$619K
 - 2005 52' TP52 \$349K
 - 1997 48' SWAN 48 \$479K
 - 2001 47' BAVARIA 47 **PENDING**
 - 2006 43' J/133 -Tango \$324K
 - 2005 43' J/133 Forgiveness \$349K
 - 2000 42' J/42 \$199K
 - 1997 42' CATALINA 42MkII \$99K
 - 1991 42' CATALINA 42 \$91K
 - 2008 41' X YACHTS X41 \$275K
 - 2007 40' J/122 - Grace \$329K
 - 1994 40' J/120 - Fee Event \$175K
 - 2004 35' J/109 - Duster II \$181K
 - 2001 35' J/105 - Hibiscus \$75K
 - 2001 35' J/105 - Hey Viento \$76K
 - 2000 35' J/105 - Kestrel \$83K
 - 1999 35' 1d35 - Relentless \$79K
 - 2013 23' J/70 **SOLD**

- ADDL USED POWER.....**
- 2002 85' AZIMUT 85 \$1,998,000
 - 2002 28' Protector RIB \$81K
- ADDL NEW POWER AVAIL....**
- 2015 54' SABRE 54 SE - IPS **CALL**
 - 2015 48' SABRE 48 SE - Zeus **CALL**
 - 2015 37' BACK COVE 37 **CALL**
- ADDL SAIL AVAIL....**
- 2015 45' HANSE New 455 **CALL**

Call Now For Pre Boat Show Specials on These In Stock Models



Available NOW!
HANSE 445



Available NOW!
SABRE 42 SE w/Zeus Pod Drives



Available NOW!
BACK COVE 37 Downeast

San Diego: 619-224-6200
Jeff Brown • Kenyon Martin
Rick Boyce

Houston: 206-285-6200
Jon Jones

Newport: 949-675-8053
Geoff Swing • Charlie Underwood

Seattle: 206-285-6200
Bob Pistay • David Wilhite

Alameda: 510-227-2100
Jack Lennox • Alan Weaver
Diego Gomez



BAY AREA BOAT LOANS

A BETTER WAY TO FINANCE YOUR BOAT

Professional • Efficient • Specialized

Marine Financing Offered Through

INTERCOASTAL Financial Group, LLC

RATES AS LOW AS 3.74% FIXED*

Debbie Betts
(510) 227-5797 Office
(510) 846-0578 Cell
dbetts@boatloans.net

www.bayareaboatloans.com

*Vessel and borrower restrictions apply. Subject to change.

LETTERS

would be far more challenging than the Fiasco, as picking the right day and time to start in order to get the best winds and best current would be of utmost importance. The Fiasco allows everyone to pick which way they want to go around the course. We're not sure if that option should be included in any San Francisco Bay Record attempt.

↑↓ HOW ABOUT THE THREE BRIDGE FIASCO COURSE?

I think part of the answer for a course for a proposed San Francisco Bay Record is already steeped in San Francisco Bay sailing tradition — the 21-mile Three Bridge Fiasco course. That event is held in the light airs of winter, however, and limited to singlehanders and doublehanders. A summertime version could be sailed by crewed boats in a single direction, which would be easier on the race committee. How about a name like the Three Bridge Loop? No matter what it was called, I think it would be great fun.

Tim Dick
Sausalito / Honolulu

Tim — Great minds seem to be thinking alike with regard to a course.

We're going to contact Mt. Gay and see if they'd be interested in sponsoring a Northern California version of the Around Jamestown. If they wouldn't be, we've got a hunch one of the Napa Valley Wineries might be interested. In the interim, and until something better comes along, we're going to call it the Latitude 38 San Francisco Bay Record. Based on the following letter, we're pretty sure we can get local marine industry companies to sponsor each of the three — and possibly more — divisions.

A race committee? We like to keep things simple, and thus wonder why record attempts couldn't be overseen by a single individual in front of the Golden Gate or St. Francis YC, along with the requirement of every boat that attempts a record having to document their attempt with a tracking and timing device such as a GPS or Spot Messenger.

We're going to mull the concept over for the next month or two, but meanwhile are welcoming suggestions on how to make it the best event possible. But we see no reason that we won't be holding the first Latitude 38 San Francisco Bay Record in the summer of 2015.

↑↓ KKMI WOULD LIKE TO BE A SPONSOR

I love Latitude's suggestion of creating an event similar to the Mt. Gay Around Jamestown Record. What a great idea!

KKMI would not only like to become a sponsor for the event, but would be happy to provide the trophies. I'm sure we can come up with some pretty cool stuff. For the Great Schooner Race, we took the original cockpit from the schooner *Santana* and turned it into a unique trophy. I'm sure we can do the same for the proposed event, maybe using some carbon parts that we extracted from *USA 76* when we refit the America's Cup yacht to carry passengers.

Please let me know how we can become more involved with this terrific idea.

Paul Kaplan
KKMI
Pt. Richmond

Paul — Thanks for your encouragement, and we'll be in touch.

↑↓ PEOPLE CAN'T SPEAK THEIR MINDS FREELY

There was another meeting of the Richardson Bay Regional Agency on October 30 to discuss the exploding number of



MARINA CORTEZ LA PAZ

Imagine YOU WERE DESIGNING
THE Perfect MARINA...

Marina Cortez has a unique combination of old-world service and the most modern marina design in Mexico.

You'll luxuriate in a level of service and comfort that goes beyond other marinas. Imagine a moorage that starts with every boat being assisted by dock staff and continues with exclusive access to a host of services that make Marina Cortez much more than a place to keep your boat. It's a place where you can make the most of every visit to this spectacular area.

Sheltered by a tranquil cove, Marina Cortez has more than 50 slips, ranging from 40' to 300' accommodating even the largest boats cruising the Pacific and the Sea of Cortez.

Everyone with a moorage at Marina Cortez enjoys these amenities and much more:

- Assistance with Immigration and Customs documentation • Cruise planning Services • Information about Doctors and Dentists • Car rental arrangements
- Recommendations for repair services as well as boat maintenance and cleaning.

CONTACT & RESERVATIONS:
Office: +52-612-123-4101 From USA: +52-1-612-157-0013
Fax: +52-612-125-4212 Email: dockmaster@marinacortez.com

Marquez de León # 2415 Esq. Topete C.P. 23060 La Paz, B.C.S. México



PROGRESSIVE

San Francisco

BOAT SHOW

JANUARY 22-25, 2015

Pier 48 and McCovey Cove
at AT&T Park



ON LAND OR IN THE WATER,
THERE'S NO BETTER PLACE TO SEE AND BUY BOATS

SFBoatShow.com



PROGRESSIVE





South Beach Harbor is a great way to experience San Francisco. Boats of all sizes are welcome in our protected deepwater harbor. Bring your boat to South Beach and enjoy all the attractions of the city.



- Two guest docks for boats up to 125'**
- 20 guest berths up to 50'**
- Casual and fine dining nearby**
- Adjacent to AT&T Park**
- Easy access to transportation**
- 24 hour security**
- Free pump-out stations**



For Reservations:
415.495.4911 (x1111)
fax: 415.512.1351

www.southbeachharbor.com

LETTERS

anchored-out boats on Richardson Bay. Ben Berto, clerk of the RBRA, presented the following as facts:

- The number of anchored-out boats has jumped from 98 in 2006 to 205 in last year's count.
- Of the 205 anchored-out vessels, only 95 of them — less than 50% — were properly registered or documented.
- As of April, 66 of the boats were two years out of registration or not registered at all. If I understood Berto correctly, under state law this means that these 66 boats are subject to being impounded.
- The RBRA has a \$450,000 grant to salvage vessels in the anchorage.

Kate Sears, who is both on the board of the RBRA and a Marin County supervisor, later reported that the RBRA had disposed of "about 300 boats" since 2010. Three hundred!

I'm sympathetic to those who are struggling and/or prefer to live an alternative lifestyle, but it seems to me that the above numbers tell the tale of elected officials and local government(s) failing to do their jobs.

Please do not publish my name. People who think something needs to be done about the exploding number of anchor-outs, and crime in the area, can't speak their minds freely.

Anonymous By Necessity
The Sausalito Waterfront

↑↓ WE HAD NO FAVORITE MEMORIES OF THE HA-HA

The captain and crew of the Chicago-based *Island Packet* 45 *Dreamtime* would like to offer the following comments regarding our experiences on the just-completed Baja Ha-Ha.

First, we found the matter of our registration for this event less than professional. While we recognize it was in part due to the fact that we left from Ensenada instead of San Diego, our waivers were delivered by hand to the organizers. The fact that there was no definitive recognition of our participation for the second and third legs — even after my personal approach to the Grand Poobah in Turtle Bay — was disappointing. My feeling is that the issue of liability had a life of its own best reflected in the Poobah's concern that everyone was accounted for in Cabo at the final signing off.

Moving on, and not to be churlish, we had great difficulty coming up with any favorite memories. Fortunately, we had no breakages or bad luck. We didn't do much fishing. On the matter of offshore impressions, I would suggest that this experience was anything but an offshore experience, starting with the almost complete lack of wind. And I think the second leg would have been as windless as the first and third legs had it not been for Hurricane *Vance*. Our ongoing journey to Mazatlan confirmed the above — zero wind. While a number of days were spent at sea, I have to say that these were probably some of the most boring passages I have been on.

Cabo San Lucas as an ultimate destination was a complete bust. I have great difficulty believing that a rally involving 100+ boats organized as an annual event cannot do better than Cabo. The fact that the marina has the gall to charge \$75 per boat for the privilege of rafting up in the marina is downright outrageous. This in combination with a second-rate anchorage should compel the Ha-Ha organizers to find another endpoint for the event.

I recognize the fact that those of us starting in Ensenada missed the festivities at the start in San Diego, but the organizers should attend to the finish of the event in a similar fashion. The sight of the finish of the sportfishing event on Friday night contrasted rather sharply with the sight of rally boats rafted six abreast in the marina, with the rest rolling in the anchorage enjoying yet another beach party as a finale.

Your full service boat yard.



Home | Services | Rates

Gallery | Links | Green Yard

Click
Our...
YARD
CAM
and
YELP REVIEWS



VISIT OUR WEBSITE:
www.boatyardgm.com
We're just a 'click' away.



**60-TON
TRAVELIFT**



**FREE
HAUL OUT
WITH
BOTTOM JOB
Reserve Space
Now!***

***Must haul by December 31, 2014
Space is limited!
First come – first served.**

IT'S SIMPLE!

Call The Boat Yard at Grand Marina for the Lowest Bottom Prices!

~ COMPARE US WITH THE COMPETITION ~

- Prop and Shaft Work
- Mast & Rigging Repair
- Fiberglass & Blister Repair
- Gelcoat Repair
- Gas & Diesel Engine Service
- LPU Hull & Topside
- Electrical Repair & Installation

CALL FOR A RESERVATION

(510) 521-6100 • Fax (510) 521-3684

2021 Alaska Packer Place, Alameda



Yacht owners trust

Pacific Crest Canvas

for the best in design, service and quality.

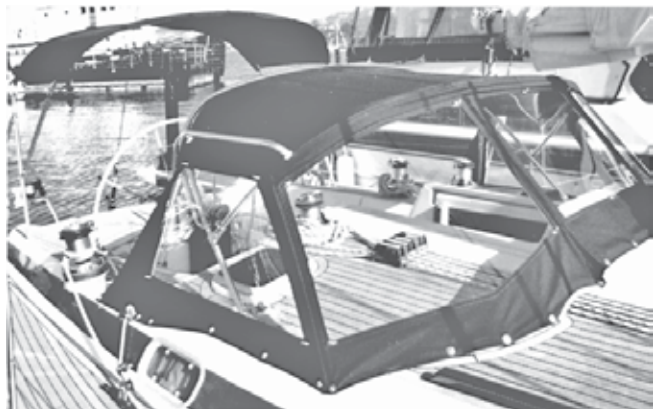

We strive to make our products the
Highest Quality at the Best Prices

With over **50 years** combined experience

Offshore Dodgers

Aft and Side Handrails
Polycarbonate Windshield
Removable Window & Covers

Full Enclosures

Sail covers, boat covers,
Biminis, weathercloths,
And everything else!

Upholstery

Exterior carpeting
Interior & exterior seating
Oceanair blinds and screens

Repairs

Window & zipper replacement
Patches and restitching
Two day turnaround!



www.pacificcrestcanvas.com

At Grand Marina, Alameda Open Mon.-Fri. 8-4
Behind Blue Pelican 510-521-1938

LETTERS

I think that the rally should come up with something besides beach parties paid for by participants. I thought the Turtle Bay function was a case in point. We must have waited for at least an hour to help ourselves to food that we brought to the event. Taking this event as an example, the organizers might have given more thought to the availability of chairs and shade, and generally been more proactive as hosts. The sight of event organizers taking shots of straight liquor did not leave me with the feeling that I was foremost in their minds.

That said, I must say the Poobah showed incredible patience assisting people in the formalities of going to Mexico, all the way down to how to behave when in Mexico. Incredible energy was spent nursing people through this process to the point that it seemed central to the marketing of this event. Again, given the fact that we did not need assistance in getting into Mexico, and did not leave from San Diego, it's hard to see what we got for the \$350 other than a backpack and a flag. We can only assume that the budget was spent in San Diego.

Obviously the Ha-Ha has been a successful event, and no doubt some will continue to see it as a success in its present form. But on *Dreamtime*, we suggest that the time is right to do some reflection on the role of the committee, particularly when the event is underway and with regard to the destination of Cabo.

Philip McManus
Dreamtime, Island Packet 45
Chicago

Philip — Thank you for your letter, as it gives us an opportunity to explain a lot of things that we perhaps mistakenly assumed were obvious to all of this year's Ha-Ha participants.

What your group on Dreamtime got for your \$375 entry fee — forget all the swag, food and beer — was the opportunity to have the time of your life along the Baja coast with over 500 fellow sailors. If you and your crew didn't take advantage of it and were bored, we suggest that you look into the mirror for the source of your dissatisfaction.

Let's see, there was light air sailing, heavy air sailing, spectacular scenery, sunny days, starry nights, a fabulous full moon, dolphins, whales, great fishing, islands, a world class baseball game, a great party on the bluff at spectacular Bahia Santa Maria, a rock 'n roll band, surfing, boogie-boarding, hundreds of sailors to trade war stories with, great beach walks, terrific locals, daily weather reports and roll calls, endless advice on anything and everything, fleet bios, an epic dance fest at Squid Roe, a great Here to Eternity Kissing Contest in the surf, sailing in company with scores of other boats, and so much else. And you were bored?! We don't mean to sound churlish either, but you and your crew might check with your physicians to see if you might be candidates for enthusiasm transplants. We're reminded of when we used to do charters in the Caribbean and we'd get an occasional guest who would plop himself in the cockpit and issue us a challenge: "Make me happy."

The concept behind the Ha-Ha has always been a simple, low-cost event for fun-loving, adventurous, self-sufficient sailors. As we always made clear, it most definitely is not an offshore babysitting service, nor is it a concierge program for people wanting to be coddled. We don't guarantee happiness on the Ha-Ha, we guarantee the opportunity to have a fantastic time.

Let's put the \$375 entry fee for a two-week event in perspective. The entry fee for the Newport to Ensenada Race is \$225, and that's only two days and 125 miles. And we're pretty sure you don't get anywhere near as much swag or food and drink. The entry fee for next year's FUBAR, which is basically a powerboat version of the Ha-Ha, is \$925, far more than double the

Come Visit Us Today!

SOUTH BEACH SAILING CENTER

at the
beautifully renovated Pier 40 in San Francisco

**Winter project you've
been wanting to do?**

**10%
DISCOUNT**

**on Interior Woodwork
& Interior Cleaning**



**"The boat looks great.
It really is a pleasure
to come back to a clean
boat. Your service is
Fantastic."**

**- David Enzminger,
Hunter 35 'Meerhexe'**

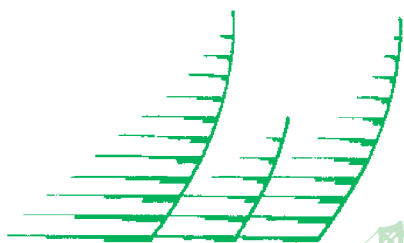

Westwind

Washing • Waxing • Varnishing



(415) 661-2205



Pier 40, South Beach on the Embarcadero • San Francisco
Call Toll Free **888-828-6789**

westwinddetailing@sonic.net
www.boatdetailing.com

South Beach Riggers

**DO IT ONCE.
DO IT RIGHT.**

PERIOD.

- Mast
- Fabrication
- Insurance Work
- Rigging
- Hydraulics
- More...

www.SouthBeachRiggers.com

415.331.3400

Come see us in Sausalito

399 Harbor Dr., Sausalito, CA 94965

8am - 5pm M - F



GIFT LIST

- Spouse
- Boat Partner
- Parents
- Crew



- Upholstery
- New Salon Cushions
- Boat Mattress
- Pillows
- Special Projects
- Bedding

GIFT CERTIFICATES AVAILABLE!

**NORTH
BEACH
MARINE
CANVAS**

Happy Holidays!

415.543.1887 nbmc@earthlink.net
www.northbeachmarinecanvas.com

Adjacent to South Beach Harbor and AT&T Park • Close to dozens of fantastic restaurants and shops



**SVENDSEN'S
CHANDLERY**

GREAT GIFTS FOR The holidays



Fisher Inflatable Stand-Up
Paddle Boards
Retail for: \$1,399.00
Sale Price: \$999.00

15% OFF

Leatherman Tools
In-stock items only.



LEATHERMAN



Offer valid through 12-31-14

OPEN 7 DAYS A WEEK!
Chandlery & Rig Shop / 510.521.8454
info@svendsens.com / www.svendsens.com
1851 Clement Avenue, in the Alameda Marina

LETTERS

Ha-Ha entry fee. As a value proposition, we'll put the Ha-Ha up against any other sailing event. The one thing we're sure of is that you've never put on a two-week event for more than 500 people in a foreign country, let alone one as complicated as Mexico, because you obviously don't have an iota of a clue of how much time, effort, and expense is involved.

While we welcome your comments, we can assure you that your overall feelings about this year's Ha-Ha are greatly at odds with those of almost everyone else we've talked to — including those of a member of the New York YC. He congratulated us for having an event "as well organized as the New York YC's Summer Cruise." He, of course, knows that they are two entirely different kinds of events for different groups of people, but nonetheless recognized the Poobah's efforts. The threat of Hurricane Vance, plus the two-day delay it caused, created many organizational challenges. Nonetheless, we can't remember a Ha-Ha in which so many participants complimented the Poobah on the way he handled things, and/or vowed to return with their own boats in the future.

Your registration wasn't professionally handled? The only reason the Ha-Ha even allows people to start from Ensenada is to accommodate sailors who, for one reason or another, wouldn't otherwise be able to do the Ha-Ha. Surely you understand there is no way that we could staff a second start in Ensenada for just seven or eight boats. By the way, you are the first Ensenada starter in the history of the Ha-Ha who has complained. Most have thanked us for being accommodating.

No definitive recognition of your participation? Are you kidding!? Did you guys not have a radio, not know how to operate it, or what? Most Ha-Ha boats communicated their positions at least nine times during the event, either directly or via relay. Our roll call sheet shows you responded to our requests for your position just three times, the least of anyone, and never while at sea. How could we recognize you if you were non-responsive? As we reiterated at the Skipper's Meeting, the primary headache for the Poobah is skippers who either don't check in during roll call or don't let two or more other boats know that they've dropped out or whatever. Not hearing from you — and we called your boat name at least three times during every daily roll call — was one of the nagging worries for the Poobah throughout the event.

Part of the mission of the Ha-Ha is to introduce cruisers to certain cruising concepts, such as cruiser potlucks. The idea behind the Turtle Bay potluck is Potluck 101, to educate new cruisers on the basics — such as that you need to bring more food than you're going to eat, you need to bring your own plates and utensils, and that you don't pile your plate higher than Mt. Everest before everyone else has gotten a chance to eat something.

More tables and chairs would have been nice, of course, because much of the normal beach had been washed away this year. We've tried to get additional chairs and tables every year, but you may have noticed there is no party rental store in tiny Turtle Bay, as the village is not accustomed to groups of more than 50, let alone 500+. Furthermore, you apparently don't understand how things work in rural Mexico, as certain people have 'rights' to certain events, and they've only got so many chairs and tables, and they just don't borrow from competitors. But if you don't want to be self-sufficient and want to do another



LATITUDE / ANDY

With hundreds of hungry sailors, it could take a while to get your food.



CAN A BOATYARD PREDICT THE FUTURE?

The future can be tricky to predict, but what Bay Marine Boatworks can do is guarantee your complete satisfaction when you bring your boat to us for maintenance and repair.

All too many boatyards promise you the moon, and in the end you find yourself paying for it. Here is our promise to you: We will inspect the work you require on your boat, and from that inspection we'll tell you exactly what we will do to fix it, how much it will cost, and when we will finish the work. All three of these commitments are guaranteed.

Even though the future is unknown, we do guarantee that when you make the important decision to bring your boat to Bay Marine Boatworks, you will find that we will do whatever it takes to make you absolutely satisfied when you leave the yard.

our mission is to guarantee absolute satisfaction to every customer



310 West Cutting Blvd., Point Richmond, CA 94804

Tel. 510.237.0140

office@baymarineboatworks.com

www.baymarineboatworks.com



West Marine®
Rigging Service

YOUR SAILING RESOURCE!

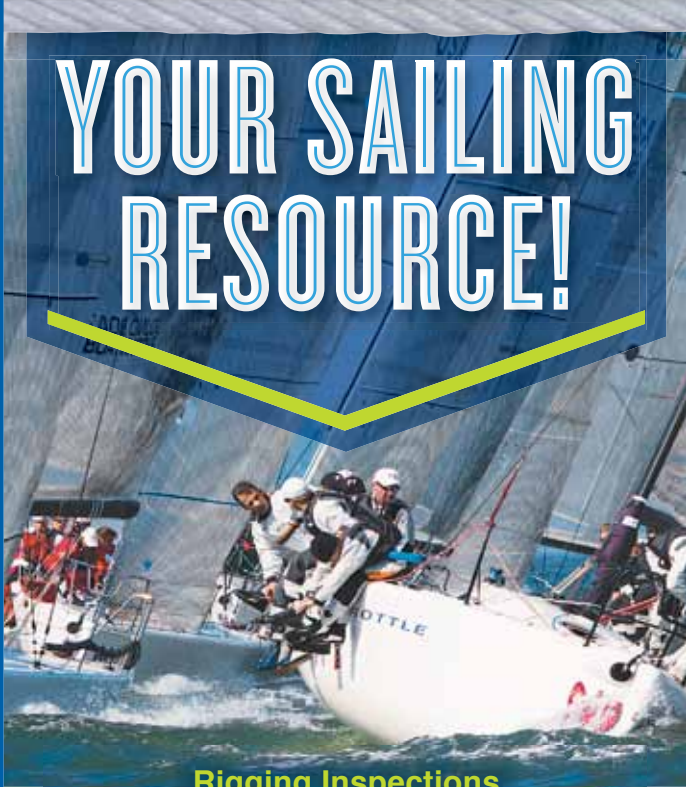

Rigging Inspections
Furler Installation • Lifelines
Running Rigging • Standing Rigging
Dock & Anchor Lines
Mobile Rigging Service Available



888-447-RIGG (7444)

**Drop off your rigging orders
at the store nearest you!**

Or visit our Onsite Rigging Locations in:

Alameda, CA • 730 Buena Vista Ave. • (510) 521-4865
Newport Beach, CA • 3433 Via Lido • (949) 645-1711
San Diego, CA • 1250 Rosecrans St. • (619) 255-8844
Seattle, WA • 1827 15th Ave. W., Ste. A22 • (206) 926-0356

www.westmarine.com/rigging

LETTERS

Ha-Ha, and are willing to pay an additional \$575 as folks in the FUBAR do, we'll find someone to make sure you get a table, chair, and shade, and will guarantee you a VIP spot at the front of the potluck line.

Yeah, the food line at Turtle Bay was too long. One reason is that we had to wait for people to bring their food in. In addition, no matter how many times we and the 'Food Police' encouraged people not to dally by inspecting all 130 dishes because hundreds of other people were also waiting their chance, it was mostly in vain. But this year's long line was on us. Next year we're going to have three or four lines with one-third or one-quarter of the selections in each line.

Event organizers taking straight shots of liquor? Oh boy, are you reading that one wrong. The Poobah was interrupted by a participant who repeatedly insisted he join him in a drink of cinnamon whiskey at the Turtle Bay beach party. The Poobah hates whiskey! But after refusing emphatic offers twice, the Poobah decided the best way to move on was to drink the shot and be done with it. Neither the Poobah — nor the Assistant Poobah, nor the Chief of Security — are shot drinkers or even moderate drinkers. Anyone on the Profligate crew will tell you that the Poobah's drink order for crew dinners is likely as not to be mineral water. Reading, not booze, is the Poobah's vice.

As you presumably did research for the Ha-Ha, you surely must have learned that the coast of Baja is well known for light wind from aft — which is why we always encourage people to bring at least one gennaker or spinnaker. Yet there you were in the 'white sails only' division. No wonder you didn't get any sailing in on the first and third legs, while a number of other boats did. And are we to understand that you are holding the Ha-Ha responsible for the lack of wind on legs one and three — as well as the post-Ha-Ha crossing to Mazatlan?

For the record, the wind on leg two — and wasn't that some thrilling sailing? — was primarily due to a front coming through, not Hurricane Vance.

Alternatives to Cabo as a final destination? We'd certainly love to hear your suggestions, because in the 60 years of long-distance sailing events to Mexico, organizers have found only six possible destinations — Cabo, La Paz, Mazatlan, Puerto Vallarta, Las Hadas and Acapulco. We don't suppose we have to go down the long list of reasons that none besides Cabo would be suitable for the Ha-Ha, but we'll start with the fact that most boats have crews, and few crews can afford to take more than two weeks off work, which precludes any other destinations. And until you've sailed into a November Norther, don't even think of La Paz or Mazatlan as possibilities.

Cabo has its pluses and its minuses, among the pluses being two of the most beautiful beaches in the world — and no, we're not talking about the one the boats anchored off. By the way, the anchorage was mostly unusually calm this year. If you thought it was roly, lord help you when you get to the mainland. We always recommend that people anchor out, because the warm water is perfect for swimming, the views are superb, and you don't get gassed by the sportfishing boats every morning as you do in the marina.

But if people wanted to get into the marina, we busted our asses to try to accommodate all of them. If you have a problem with the marina rates, we suggest you take it up with the marina management rather than the Ha-Ha, as we have nothing to do with the rates and don't get kickbacks. And maybe you didn't hear, but Hurricane Odile came through Cabo two months before with winds of 120 knots, knocking out 35% of the marina's slips. Not that most marinas in Mexico keep 135 empty slips for boats that will stay just a night or two.

The one point on which we'll wholeheartedly agree with you

Your engine.



Your pit crew.

CERTIFIED SAIL CARE

- ✓ Free 10-point Sail Inspections
- ✓ Sail Repair
- ✓ Expert Upgrades & Recuts
- ✓ SafeGuard Hand Sail Washing
- ✓ Climate Controlled Sail Storage
- ✓ Sail Measurement
- ✓ Canvas & Sail Covers
- ✓ Hardware Conversions & Upgrades
- ✓ UV Cover Re-stitching & Replacement
- ✓ FullBatten™ Conversions
- ✓ Pickup & Delivery

The North loft that provides you with the world's leading sails also provides the world's leading sail care... all certified to North Manufacturing Blue Book quality standards for construction and materials (even if your sail was made by another sailmaker). Now is a great time to contact your North Certified Sail Care team... we'll help you get more out of your sailing.

The Power to Perform



Channel Islands 805-984-8100 **Costa Mesa Sail Care** 949-645-4660
Marina Del Rey 310-827-8888 **San Diego** 619-224-2424 **Sausalito** 415-339-3000

www.northsails.com   

Official Sponsor
2014 BAJA HA-HA

ONLY IN MARINA VALLARTA...

352 VESSEL CAPACITY (UP TO 160 FEET). ELECTRICITY, WATER, PUMP OUT, 88-TON TRAVELIFT, DRY DOCK, RESTAURANTS, SHOPS, HOTELS, AIRPORT. PRIME LOCATION, COORDINATES: LAT: 20.39 N, LONG: 105.15 W

Marina Vallarta
BAY VIEW GRAND

MARINA VALLARTA
TELS. +52 (322) 221-0275
+52 (322) 221-0722
PUERTO VALLARTA, JAL. MÉXICO

OPEQUIMAR
CENTRO MARINO

www.marina-vallarta.com.mx ~ italia@marina-vallarta.com.mx

YOUR SAILING HOME

MARINA BAY YACHT HARBOR

RICHMOND CALIFORNIA

Great Location Deep Draft

Reserve today
(510) 236-1013
www.mbyh.com

CLEAN MARINA

LETTERS

is that the beach party/awards ceremony, which had to be combined because of losing two days to Vance, was a complete disaster. Normally the Ha-Ha gets the best site on the beach for the beach party, away from all the raunchy stuff that everyone unfortunately was exposed to this year. But we were a day late and our normal site was booked for a wedding.

We guess there is no way for you to have known except by looking at the schedule, but in addition to a beach party, the Ha-Ha normally also has a three-hour awards ceremony by the marina office, with a good sound system and often appearances by the mayor and other dignitaries. There is unlimited beer and sodas for everyone, every participant gets recognized, and there is lots of humor and prizes. It's easily the equivalent of the kick-off party in San Diego.

With Cabo having so few post-hurricane tourists, the Poobah and the management of Mango Deck thought we could perhaps share their facility and have things work out reasonably well for a combined beach party/awards ceremony. Alas, we both underestimated the appeal of drinking contests and lap dances, and the awards ceremony part of the beach party was an unmitigated fiasco. The decision to try to hold the awards ceremony on the beach was a blunder on the Poobah's part. We suppose we could beat ourselves up about it, but what would be the point?

The Poobah has managed 20 Ha-Ha's and supervised the start and the finish of the only other one. Because of all the uncertainty with Mexican paperwork, the loss of two days caused by the threat of Hurricane Vance, and several other potentially significant problems that were out of the Poobah's control and not on anybody else's radar, this was far and away the most difficult Ha-Ha to manage ever. You're entitled to your opinion, but knowing what we know, and given the circumstances the Poobah had to deal with, we're confident that he did about as good a job as could have been done. The Poobah's purpose in life is to try to help as many people as possible to have a little fun. His head is held up high.

But we thank you again for your letter, as we think it will clarify the nature of the Ha-Ha for a lot of prospective participants. The Ha-Ha is for adventurous, fun-loving, self-sufficient, roll-with-the-punches sailors only. It is definitely not for those looking for guaranteed weather conditions, American-style beach party facilities, guaranteed marina slips, and an otherwise pre-digested experience. The Ha-Ha is cruising, and when you cruise, you get the pleasant and sometimes you get the less-than-pleasant. If the Ha-Ha is not what somebody is looking for, we beg you, don't sign up. And don't worry about hurting our feelings, as we'd prefer to have a great time with 25 boats full of fun-loving, adventurous sailors rather than a huge fleet peppered with people inclined to whine over minor inconveniences beyond anyone's control.

↑↓ ENGINEERS LOVE TO SCREW WITH US

I empathize with your frustration over your replacement masthead light's having different screw holes and a different electrical connection, even though made as the replacement by the same manufacturer. It's the engineers. They love to screw with us. LOL.

I replaced the old Whale foot pump in my galley. Same exact pump, different hole pattern! Aaarrggghhh!

Frank Nitte
Windsong, Islander Freeport 36
Balboa YC, Panama

↑↓ SQUARE PEGS DON'T GO INTO ROUND HOLES

My condolences on the anchor light's going out on *Profligate's* Lunasea LED masthead light, and the problems you've

CALIFORNIA'S MULTIHULL LEADERS

WEST COAST MULTIHULLS



BEST MULTIHULL BROKERAGE



CORSAIR 31
Three from \$85,000



BRAZAPI 51
2005 • \$525,000



PDQ 32 CATAMARAN
A cool #10 • \$120,000



FP MARQUESES 56
1997 • \$549,000



34' GEMINI 105 MC
Three from \$71,000



NORSEMAN 400
Liveaboard • \$157,000



2001 LEOPARD 38
Very clean! • \$229,000



SUNCHASER 58
Priced to sell at \$545,000



SEAWIND 1160
2009 • \$400,000



FUSION 40
2012 • \$427,000



CORSAIR 28
2006 • \$68,000



SPRINT 750 MKII
2012 • \$64,500



FOUNTAIN PAJOT BELIZE
2002 • \$324,000



TELSTAR 28 TRIMARAN
w/50hp OB/trailer • \$70,000



DRAGONFLY 35
2012 • \$395,000

NEW BOATS News • Events

Introducing the **NEEL 45 TRIMARAN**



The Neel 45, a three-hulled wonder and a blast to sail, is one of the coolest boats introduced for 2013."

– Herb McCormick,
Cruising World

The Neel 45 is the type of bold, high-performance multihull which should appeal to any West Coast sailor looking for innovative design, quick sailing characteristics plus comfort and stability. Low volume builder means 'order now' to be the first to get one on the West Coast.

Fountain Pajot
CATAMARANS

CORSAIR
MARINE

SEAWIND

CATANA
CATAMARANS

GEMINI
CATAMARANS

DRAGONFLY

San Diego
Monte Cutrell (619) 319-0136
monte@westcoastmultihulls.com
Northern California
Don Margraf (510) 469-3330
don@westcoastmultihulls.com



CATAMARAN LESSONS/CHARTERS

Learn to sail or charter from our exceptional San Diego Catamaran fleet!

San Francisco
(510) 865-2511
helmz@aol.com
www.helmsyacht.com

HAPPY



HOLIDAYS



ENJOY 2015 AT YOUR NEW MARINA



ALAMEDA, CA
WWW.FORTMAN.COM
(510) 522-9080

BEST VALUE ON THE BAY

LETTERS

had with trying to fit their replacement light in the old holes. I have been through three of those Lunasea masthead lights. The



LATITUDE / RICHARD

Replacing entire fixtures — rather than just a bulb — wouldn't be so bad if companies would keep the same mounting and connection schemes.

first two didn't work at all, but Lunasea replaced them at no charge. The third one doesn't work as a nav light, but so far it's been a great anchor light, and while we're in the Sea of Cortez I don't really need a masthead nav light. I think Lunasea finally decided they had to re-engineer them. And they did send me one of the new ones as well. I'm not going to try to install

that one as long as light number three is still a good anchor light.

Lunasea told me the reason for their new electrical connection was to save the weight of a fourth wire, because that's what the carbon-mast racing crowd was looking for. Hmmm, could be.

Alan Bradley
Vivacia, Caliber 40LRC
La Paz, BCS, Mexico

Alan — We've used a lot of Lunasea products, and this is the first one that has failed. That said, the fact that there is an entirely different electrical connection, and that the screw holes are different, is not user-friendly at all. It took professional riggers a full day's worth of work to replace that single light.

⇕ OTHER COMPANIES USE THE SAME TRICK

While we have not recently come across replacement parts that don't fit in the hole patterns and with the electrical connections of the originals, it's always a battle trying to find the right parts for Jabsco manual heads, as you need to know the handle color and when the unit was made.

We recently tried to rebuild a Lewmar 43ST winch, only to find that two of the parts that we needed were no longer made, nor could Lewmar provide working drawings so we could have the parts machined. Lewmar advised us to find another winch, take it apart, and measure the parts. They also recommended a new replacement winch, but failed to mention that the mounting bolt pattern was very different. We didn't discover this until the client had purchased it and brought it to Mexico.

Ever try to find an adapter for standard NPT or metric oil-pressure and water-temperature sending units for Yanmar engines? Yanmar uses a special metric thread only found in Japan, so you can't simply use a VDO or Sierra sender and gauge. We finally found an aftermarket adapter from a tractor dealer on the Internet.

Then there is Raymarine's practice of introducing yet another communication protocol — which is not backward compatible. SeaTalk, SeaTalk2, SeaTalkHS, SeaTalkNG (almost compatible with NMEA 2000), and now Raynet. Add to that the inability of many of the new chartplotters to send and receive NMEA 0183 without the purchase of a converter box — some not even sold by Raymarine — and you get a another frustrating situation.

We recently installed a Standard Horizon Matrix GX-2150 with AIS, and purchased an NMEA 0183-to-SeaTalkNG adapter so we could hook it up to a new Raymarine A78. We

EXCEL UNDER PRESSURE

Introducing Stratis ICE, Doyle's revolutionary new Lightweight, High-Strength and Durable Fiber for the ultimate performance sails. ICE combines the strength of Para-Aramids like Kevlar and Twaron, weight savings equivalent to 100% Carbon sails and an unmatched ability to resist flex fatigue. Stratis ICE is ready to deliver sails that will go the distance, time after time.



Doyle San Francisco
Bill Colombo
Josh Butler
(510) 523-9411



MARINA AMENITIES

- Full service harbor master's office
- Waterfront dining
- Free WiFi access
- Guest facilities with restrooms, showers and dressing rooms
- Water sport rentals
- Surveillance and electronic controlled gates
- Individual water hook ups
- Garbage and recycling disposal



Sausalito's Finest Marina

85 LIBERTY SHIP WAY, #205, SAUSALITO, CA 94965

415•331•5550

FAX 415•331•8523

www.schoonmakermarina.com

LETTERS

found that the converter sold by Raymarine was only good for one-way, and only one channel of NMEA 0183, which allowed us to send a GPS signal from the chartplotter to the radio, but did not allow the AIS NMEA 0183 signal to be sent to the chartplotter. This requires a separate converter, and Raymarine referred us to a third-party source for the converter.

Oh yes, I almost forgot. Village Marine Tech watermakers now use a 19-inch pressure vessel, so the standard off-the-shelf 21-inch membrane won't fit. They conveniently sell the 19-inch, but at a premium. If you have an old unit with the standard 21-inch membrane, they will sell you a 19-inch membrane and give you a 2-inch spacer. The 19-inch membrane is not available on the aftermarket.

Dennis Ross
Ross Marine Services and Consulting
Two Can Play, Endeavour 43
La Paz, BCS, Mexico

↑↓ LED LIGHTS ARE AMAZING, BUT . . .

While I was supposed to be working, I caught the Wanderer's gripe in *'Lectronic Latitude'* about the same brand replacement LED masthead light's not fitting the old screw pattern or electrical connection. I used to work at West Marine in Long Beach, and heard similar complaints all the time. I think it was either Perko or Marincos that was notorious for changing base fittings.

As for LED life and intensity, I suggest you Google 'LED Lumen Depreciation' when you get a sec. LEDs are amazing, as they don't draw much juice, they last a long time, etc, etc — but early on they lose their initial intensity. After that, they cook right along for years. As with all computer chips, heat is the enemy. I suspect the lifespan reports in the marketing literature are based on controlled lab conditions. Living up on a masthead in Baja probably isn't the best environment for the long life of an LED.

LED lumen depreciation would make a good subject for a future Max Ebb column. Lee Helm could then explain why the LED running light on her kayak isn't as bright as it used to be.

Stefan Svlich
Alexandria, Virginia

↑↓ THE PROBLEM IS TOO MANY VOLTS, NOT TOO FEW

Hubby Dave, who's an electrical engineer, says the reason LED light strips go dim is not that they aren't getting enough voltage, but because they are getting too much voltage. The older LED light strips were not regulated, so when a battery was charging at 14 volts, they were getting too much voltage, which is what wore them out before the advertised 30,000 hours. The newer LED light strips have regulators and thus should last longer.

Melissa DeLong
Apsaras, Hunter Passage 450
Woodinville, Washington

Melissa — Interesting explanation. At this point we'd guess we've lost about 20% of the strips' intensity. If they stay at this level, they are still plenty bright.

↑↓ THE COMPLETE GUIDE TO LED LIGHTS

Like your LEDs, I'm getting 'dimmer' with age, too. But unlike your LEDs, I was never too bright to begin with. Here is my conjecture: With single-color LEDs — red, green, blue, and such — the LED 'chip' itself emits the visible light. The color you get is set by the chemistry of the chip. The light



Marina CostaBaja, at the Gateway to the Sea of Cortez in La Paz, South Baja.

Marina CostaBaja's protected location, concrete docks and double basin design offers controlled access to 250 prime slips for vessels ranging from 30-200 feet.

OUR PRIME FACILITIES

Potable desalinated water • Secure dock boxes • Largest fuel dock in the area • Crew lounge
Pump out service • 24 hour security • Laundry service

Visit CostaBaja, a master planned community and enjoy Golf or relax at the Beach Club or choose your future home among a variety of Condos, Villas and Townhouses.

Discover the most beautiful bays, islands and marine life in what is known as "The Aquarium of the World".



COSTABAJA

Unique living on the Sea of Cortez
marina • golf • residences

Gabriel Ley (Marina Manager)
marina@marinacostabaja.com
Toll Free 888-866-9394
www.marinacostabaja.com

WHALE POINT MARINE & HARDWARE CO.

A FAMILY OWNED & OPERATED BUSINESS FOR THREE GENERATIONS
MARINE PARTS & ACCESSORIES, PLUS A COMPLETE HARDWARE STORE

www.WhalePointMarine.com

AIR DRYR 1000



Handles up to 1000 cu. ft.
 Safe for marine use.
Now \$59⁹⁹

FURRION Shore-Power Cord 30AMP



25' **\$69⁹⁹**
 50' **\$89⁹⁹**

GOLDBRAID Nylon Dock Lines

With approx 12" loop in 1 end.



3/8" x 15' **\$9⁹⁹** 1/2" x 20' **\$16⁹⁹**
 3/8" x 20' **\$12⁹⁹** 5/8" x 20' **\$26⁹⁹**
 1/2" x 15' **\$16⁹⁹** 5/8" x 25' **\$39⁹⁹**

FENDERS

Lifetime warranty



Twin-eye Fender Hole-thru-middle Fender
 5" x 18" **\$13⁹⁹** 6.5" x 15" **\$29⁹⁹**
 6" x 22" **\$19⁹⁹** 8" x 20" **\$49⁹⁹**
 8" x 26" **\$29⁹⁹** 10" x 26" **\$74⁹⁹**

CHART BOOKS



The convenience of many charts combined into one book that fits on your chart table.
 No. California: **Now \$49⁹⁹**
 So. California: **Now \$39⁹⁹**
 Panama - Mexico: **Now \$89⁹⁹**
 Pacific Northwest: **Now \$89⁹⁹**

AQUA MAT

6 pack of 1 sq. ft. tiles.



List \$42.99 • **Now \$35⁹⁹**

FOULWEATHER GEAR by Dutch Harbor



NOW \$49⁹⁹ - 69⁹⁹

The affordable protection. Full suit includes jacket and bib-pants.

GILL Deck Boots

Stay dry and warm. 100% natural rubber, removable inner cushion, non-slip sole, reinforced heel and toe.
 Mid calf length and knee high boots.
 Short: **Now \$59⁹⁹**
 Tall: **Now \$69⁹⁹**



205 Cutting Blvd, Corner of 2nd, Richmond
510-233-1988 • FAX 233-1989
 Mon-Sat: 8:30am - 5pm • Sun: 10am - 4pm • whalepoint@acehardware.com
 Go to www.WhalePointMarine.com for additional discounts!

LETTERS

output stays pretty much constant until the chip up and dies sometime in the distant future.

White LEDs work more like fluorescent tubes in that they generates UV light internally. Those short-wavelength photons strike the phosphor coating inside the tube, which raises the energy level of those phosphors, and when they 'drop back' to normal level, a longer-wavelength photon is emitted from the phosphor atoms. Each phosphor — it's a blend — radiates its own color. The blend includes phosphors that radiate different colors, and your eye blends them together to make white. Different blendings of phosphors give different tints of white

Still awake? 'White' LEDs start with a blue LED and have a drop of blended phosphor coating over the top. The blue light excites the phosphor blend — same as a fluorescent tube — and you get some flavor of white light depending, again, on the blend used.

The biggest enemy of these LEDs is temperature. An LED is a tiny device. Those strip LEDs don't let the heat go away from the tiny chip very well, so naturally the temperature at the chip rises. Phosphor output diminishes with a 'Time-Times-Temperature' characteristic, so if the temperature goes up, the output goes down more rapidly. Did you ever notice a burn-in on a CRT computer monitor? Same thing, as the burnt areas had an electron beam landing on them — adding heat — more than the surrounding areas, so they faded more quickly. The biggest problem for LED replacement-lamp designers is getting the heat out of there so the chip stays cooler.

I'm guessing the original ratings for the chips in LED strips were derived from chips that had proper cooling. Being embedded in plastic impairs the cooling. Look at the replacement bulbs for household use, they are mostly aluminum heatsink.

It could be that using a stabilized voltage source at 12 volts — instead of running the LEDs off the house battery and charging system, which can reach over 14 volts — would prolong the life of the LEDs. There are 'DC to DC' converters available to accomplish this.

Sophisticated LED lamp assemblies also use a regulated circuit to hold the current through the lamp constant. The strips use 'passive regulation', which is a resistor in series with the LEDs (usually one resistor for each group of three LEDs) so if input voltage rises the current will rise, too. Three white — blue, really — LEDs will have a total voltage drop of about 10.5 volts. If the series resistor is set to operate at maximum rated current at 12 volts, and the voltage goes up to 13.5 volts, the current will pretty much double, exceeding the design limits and reducing the life of the LEDs. I have mounted my LED strips inside aluminum channels, for both physical protection and improved heat dissipation. We'll see if they still work in ten years.

Thanks for all the publisher and *Latitude* staff do — a consistently great sailing magazine with great content. All that and the Ha-Ha, too! Next year might be my year, as I retire to my fishing shack on the Columbia River the first of the year so I can work on my boat.

Mark Sutton
 Portland, Oregon

↑↓BEST COVER EVER

I was hoping to do this year's Ha-Ha, but had to drop out when the opportunity arose for a long-postponed hip replacement surgery. The operation was a great success, and I'm eager to get back on the water. My sweet bride went the extra mile on her way to visit me at the hospital in Vallejo, stopping at

Easy Access

EMERY COVE YACHT HARBOR

In The Center of San Francisco Bay Perfect Location - Great Investment!

BUY OR RENT A SLIP

- BUY A SLIP - Save money and earn equity! Enjoy tax savings. Listings start at \$32,000. Emery Cove Yacht Harbor is the only marina on the Bay with FEE SIMPLE (not a grounds lease) dockminium ownership.
- RENT A SLIP - 35-60' slips, rates from \$9.80 to \$10.80 per foot.

AMENITIES

- Wide fairways, free wireless, modern facilities and Marina Guard® ground fault monitoring.
- Restaurants and shopping within walking distance.
- Free bus: Emery-Go-Round to Bart & Amtrak

ON PREMISES

- Emeryville Yacht Club
- Magnificat 4 Charter
- Mathiesen Marine
- Rubicon Yachts
- Seaward Coastal Ventures
- Websolar



CALL FOR AN INFORMATION PACKET | 510-428-0505

3300 Powell Street, Emeryville, CA 94608 | www.emerycove.com | Email: info@emerycove.com

WWW.RUBICONYACHTS.COM

RUBICON YACHTS

EMERY COVE • SAN RAFAEL • SF



56' PHILBROOK AEROCAT, 2003
\$775,000
Emery Cove (510) 601-5010



44' BENETEAU 440, 1995
\$170,000
Emery Cove (510) 601-5010



40' CATALINA 400, 1995
\$122,500
San Francisco (415) 484-1300



39' CAL, 1988 \$77,000
Emery Cove (510) 601-5010



38' HANS CHRISTIAN MK II, 1982 \$69,000
Emery Cove (510) 601-5010



37' JEANNEAU SUN ODYSSEY, 2001
\$89,000 Emery Cove (510) 601-5010



37' GULFSTAR SLOOP, 1977 \$49,000
Emery Cove (510) 601-5010

3300 POWELL ST., EMERYVILLE (510) 601-5010 • 25 THIRD ST., SAN RAFAEL (415) 453-4770 • 48 COLIN P. KELLY JR. ST., SAN FRANCISCO (415) 484-1300

NOW OFFERING COVERED SLIPS FOR SAILBOATS



**THAT'S RIGHT...
YOU HEARD CORRECTLY**

- Of course you have to remove your mast
- We will unstep your mast...*on us*
- We will store your mast...*on us*
- You get your sailboat in a covered slip

*When its time
to go sailing again,
We will step your mast...on us*

Call for details

NAPA VALLEY MARINA

1200 Milton Road • Napa, CA 94559
(707) 252-8011 • Fax (707) 252-0851
www.napavalleymarina.com

Marina • Boatyard • Chandlery • Brokerage

Dealers for
YANMAR

Interlux
yachtpaint.com

Distributors for *Brownell*
Boat Stands

LETTERS

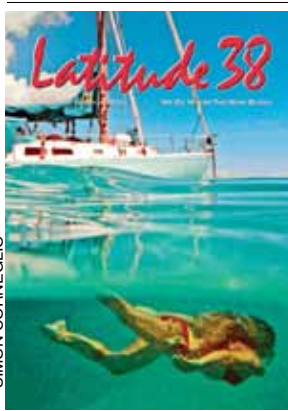

SIMON CORNEGLIO

Napa Valley RV & Marine to pick up the latest copy of my favorite magazine. She and I both agreed that the cover photo was awesome — one of *Latitude's* best ever.

Bill Crowley
Clarsa, Ventura 23
Napa

Bill — Sailboatophiles recognized the boat as a Cal 40 and deduced that the photo was likely of Liz Clark of the Santa Barbara-based Swell. How right they were.

We received a lot of compliments on this cover featuring Liz Clark and her Cal 40 'Swell'. We like the photo for a variety of reasons. It's unusual to get above- and below-water perspectives at the same time. The photo is divided into harmonically pleasing thirds, with numerous shades of blue and green. One of the highlights of the photo is a fit female form seen swimming along the bottom. You can't lose with something like that. The photograph was taken by Simon Corneglio. Nice shot!

↑↓ HOW TO VOICE YOUR OPINION TO NATGEO

I've done a couple of Ha-Ha's and had great fun. But I'm writing in regard to your November 17 'Lectronic, in which you asked whether *National Geographic* should be encouraging people to vote for one of their 10 candidates to be 'Adventurer of the Year'. I absolutely agree with *Latitude* that they should simply list 10 of the more adventurous people rather than have people vote on who is 'the most adventurous', which is completely subjective.

But did I miss something? How do we communicate our feelings about this to *National Geographic*? Is there an email address or something?

Buck Hoelscher
Pacific Crystal, Cape George 36 Cutter
Pleasure Point, Santa Cruz

Buck — You can express your opinion, as we already have, to ngsforum@nationalgeographic.com. Since we forgot, you might ask National Geographic how they prevent ballot stuffing.

By the way, we haven't been to Pleasure Point in years, but used to surf all the breaks from Sewer Mouth to The Hook on a 10-ft board built by future ultralight-displacement boat pioneer George Olson. Geez, that water was cold in the winter.

↑↓ 20 KNOTS DURING THE DAY AND 15 AT NIGHT

I'm hoping to do an Atlantic Rally for Cruisers (ARC) in a year or two on a catamaran of my own, so I've been following some of the blogs — including that of the *Outremer 64 Malisi*. Their most recent posting reminded me of something the *Wanderer* wrote last month about not wanting to do more than 20 knots during the day with *Profligate*, or more than 15 knots at night. Here's the report, with my having cleaned up some of the broken English:

"November 13. We are lead boat heading for the ARC+ stop at the Cape Verde Islands, but are not doing as well on handicap. One reason is that we've been two days without a spinnaker, and have thus been slowed down. We feel like a lame duck.

"How did we lose the spinnaker? Well, we pushed our luck the night after the start of the ARC+. The tradewinds, increased by passing between the Canary Islands, blew at up to 29 knots. We were dashing down the Atlantic swells with a full main and the spinnaker. We were hearing all kinds of sounds that

COME VISIT COYOTE POINT MARINA

The Peninsula's Complete Recreational Destination!



**NEW
45'-60' SLIPS
AVAILABLE**



BERTHING

- Slips to 60' available
- Inside ties from \$100 per mo.
- Multihull side ties available
- Check out our rates!



FUEL DOCK & PUMP OUT

- Open 7 days per week
- Gas and diesel available
- Check our prices
- Free pump outs

**Fuel Dock
Re-opening
Soon.**

COYOTE POINT MARINA ~ 1900 Coyote Point Drive • San Mateo

650.573.2594

CAT[®]

Authorized Cat Marine Engine Dealer

**COMMERCIAL MARINE &
PLEASURE CRAFT SALES/SERVICE**

Dockside facility at KKMI

Complete marine engine service, from oil changes to overhauls

530 W Cutting Blvd, Richmond, CA 94804

(888) 407-7301



www.petersonpower.com/onthewater

KISSINGER CANVAS

Marine Canvas & Interiors

STEVEN KISSINGER

(925) 825-6734

Covering the Entire Bay Area

- Biminis
- Enclosures
- Boat Covers
- Cushions
- Sail Covers
- Awnings

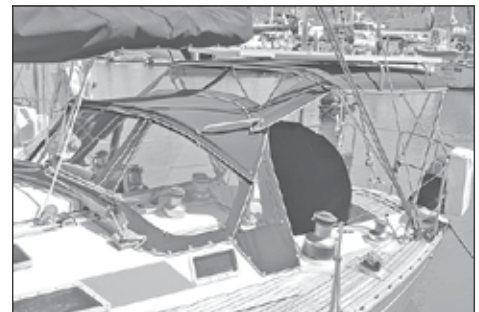

DODGERS

20 Years in Business

Side handrails and window covers included.

OPTIONS

Aft handrail, dodger cover, sailing bimini.

Free Estimates and Delivery



Check out our "Must-See" website!!

The Iverson's Dodger is now available in the Bay Area!

Dodgers • Bimini Tops • Enclosures



206-849-2274

www.iversonsdesign.com

#1 Selling LED Brand
Dr. LED
LED Lighting ●●●



The Navy specifies the use of Dr. LED's lights...Shouldn't you?

**Dr. LED High-Quality Marine LED Products you can count on!
Designed in the USA and built to last.**

www.DoctorLED.com
Promo Code: LAT38

LETTERS

start being made when the boat gets going fast. When *Malisi* hit more than 20 knots on the speedo, the singing got louder. It was beautiful like a humming choir, but threatening, too.

"With the singing coming and going, one's attention gets stirred up and it makes it hard to sleep. The sounds makes you feel awake all of a sudden and your body gets ready to respond — even if 22 knots is not that fast. I could do it on my bicycle. To calm myself, I would think about cycling downhill through the countryside with the wind at my back on a nice summer day.

"Shortly after I finally managed to fall asleep, there was a knocking at my cabin door by Matt, my mate. 'We've been called on deck,' he said.

"Is it urgent or do I have enough time to dress in peace?' I responded.

"I think it's urgent.'

"When I got on deck there was an uproar. Somebody had gotten the spinnaker wrapped around the furled genoa and couldn't get it undone. There didn't seem to be any way to get the chute unwrapped, and even if we could, it would be a nightmare getting the huge spinnaker dropped in such high winds. What it meant is that we couldn't stop the boat even if we wanted to. Sort of like being on a runaway carriage where the horses have taken off in a mad panic. All you can do is hope the horses will get tired before the carriage gets torn apart.

"I tried to stay calm, as I always try to do on yachts, but it was really difficult with the chute looking like an hourglass. The crew was standing on the foredeck pointing their flashlights at the wrapped spinnaker, wondering how much flapping it could take before it was torn apart. Meanwhile, the big cat, being driven by the autopilot, was running down the waves and whitewater was spraying up through the forward netting.

"It took us what seemed like ages to come up with a plan. We wrapped a line around as much of the bottom part of the hour-glassed sail as we could, trying to prevent it from repeatedly being filled. After we did that, six of us managed to get the bottom of the spinnaker rotated around the furled headstay to get the wrap out, allowing us to lower the halyard. Whew!

"When dawn broke, we were only 50 miles from the African coast. It would have been an ideal place to make a stop, but we gybed so the Cape Verde Archipelago, our first stop, was 700 miles dead ahead.

"The next day we were once again sailing down the Atlantic swells. Sometimes it felt as though we were riding a sled like when we were kids. You know that special moment when you let go of the ground and the sled takes off down the hill? Surfing downwind at high speed feels a lot like that, as the gravity pulls you down and the boat gets a speed assist from the push of the wind and waves. But on the ocean, the 'hills' you slide down never stop.

"On Monday evening, the wind came up to about 29 knots again, and once again we got caught with the spinnaker up. This time I was on watch. Then there was a gust and we heard what sounded like a knife cutting through silk. It was the spinnaker tearing in half. Half of the chute was fluttering from the top of the mast while the other half was dragging in the water with the sheets. With our biggest sail in shreds, it was a dark moment for our ambitions to win the rally."

The piece was written by Rainer Holtorff, who is helping deliver the boat across the Atlantic to the Caribbean, where he will be the boat's captain for the winter.

Does the Wanderer/Poobah have any thoughts based on his experience?

Jason Witrow
Annapolis, Maryland



INSURING BOATS & YACHTS FOR OVER 50 YEARS

Contact Us for a Quote

www.marinersins.com

N. California
Carolyn Pounds
carolyn@marinersins.com
510-254-3689

L.A./Orange Co.
800-992-4443

San Diego
800-639-0002

Exclusive MARINERS *Odyssey*® Program

Mexico
South America
South Pacific
Caribbean
Mediterranean

Racing Sailboat Program

Transpac
Pacific Cup
PV / Cabo Races
Caribbean Regattas

Providing Cruisers and Racers All Over the World
with Prompt, Reliable Service since 1959

Corporate Office: 206 Riverside Ave., Suite A
Newport Beach, CA 92663 / Ins. Lic. #0D36887



Custom Canvas & Interiors



The Gianola Family has been designing and fabricating custom canvas and interiors since 1969. Gianola Canvas Products offers you the best in quality, more choices, and personal service.



265-B Gate 5 Road
Sausalito, CA 94965
(415) 332-3339
www.gianolacanvas.com

HOPE FOR THE BEST. PREPARE FOR THE WORST.

Ultra Flip Swivel



The strongest most reliable
device to connect rode to anchor

Toronto Boat Show
January 10 - 18

San Diego Boat Show
January 22 - 25

Seattle Boat Show
January 23 - February 1

Ultra Marine West
HOME OF THE ULTRA ANCHOR

(714) 843-6964
www.ultramarinewest.com
www.quickline.us



RE-RIG WITH THE BEST



The best lines for your race campaign in stock — upgrade this winter!

Call for consultation and estimate.

HANSEN RIGGING

2307 Blanding Ave., Alameda • 510.521.7027

www.hansenrigging.com



Direct benefits

It's easy! With your new sail order from *North Sails Direct* you measure, you SAVE, you get the best. *Contact us today!*

FREE!
ONE YEAR
SAIL CARE
& REPAIR
with purchase of
a new North sail*

*Restrictions may apply. Ask your North Sails Direct representative for details.

NORTH SAILS direct



northsailsdirect.com or call 888-424-7328

Boat size restrictions may apply.

LETTERS

Jason — To give readers some background, the Outremer line of catamarans is among the fastest and most seaworthy of those built by the French. However, they are not typical in that they have shockingly small — for their length — saloons and interiors.

The one thing all veteran catamaran sailors will tell you is that you do not want to get caught with too much sail up. Besides, once the wind gets up above 18 knots, more power is about the last thing any catamaran needs.

The way to deal with a wrapped chute is to gybe and recreate the situation on the other gybe that caused the wrap in the first place. Once you get a reverse vortex going by sailing really deep — it's a very fine line between that and gybing again — it's often possible to get even the most badly wrapped chute undone, almost as if by magic. Oftentimes the bigger problem is pulling off a successful gybe in nearly 30 knots of wind — where the force is four times as much as in 15 knots of wind. Naturally it's harder to do this at night. If you practice unwrapping a spinnaker during the day in moderate winds, you can get pretty good at it.

Or, if you have a crewmember like Fin Bevin on Profligate during the Ha-Ha, you make an anti-wrap device out of a few hanks and a series of lines that prevents the chute from blowing inside the headstay and wrapping.

We fully identify with Holtorff getting tense when Malisi was creaming along at over 20 knots, as it's hard to believe that such a big box-shaped sailing vessel should be going so fast. Not that we've had any failures on Profligate as a result of doing it. But even if it's smooth, you mentally and physically brace yourself for possible problems.

The thing that puzzles us is Holtorff's statement that it's a "nightmare" to drop a chute on a cat in a lot of wind. We haven't found that to be the case at all. The combination of a big ease on the foreguy and grinding in on the sheet will flatten the chute and dramatically depower it. If you then lower the main traveler as far as possible and ease the main way out, the chute will be completely blanketed. This makes it easy to drop the chute on the tennis court-sized foredeck of a cat.

In our view, when the wind comes up on a cat, the real trick is not dropping the chute but rather reducing the size of the mainsail. Many, many catamaran skippers have told us they go to single- or even double-reefed mains at night on the ocean where the weather is unsettled or there are squalls. We've hardly ever reefed Profligate, but decided to give this approach a try on the windy second leg of this year's Ha-Ha. We are converts, as Profligate still had no trouble hitting 20 knots in about 18 to 20 knots of wind, and even with a big first reef, the main was still large enough to completely blanket the spinnaker when we decided to drop it.

It's been our experience that it's easy to drop the chute on cats but hard to reduce the size of the main when sailing off the wind. With monohulls, it's harder to drop the chute because it's more difficult to blanket it with the main, and the foredeck is so much smaller than on cats. Reefing the main isn't such a critical issue on a monohull — if you're greatly overpowered, you might get knocked down, but you won't get flipped as you might on a cat. We remember once carrying a full main on our Ocean 71 Big O off Cuba in 49 knots of wind. We ran off with it a bit and it wasn't a problem. If we ever get caught with a full main up on Profligate in 49 knots of wind, we may not flip or be dismayed, but we will need a new pair of shorts.

ARE ADVANCE CREW LISTS REALLY REQUIRED?

I was not a participant in the Baja Ha-Ha, but I read your articles about the documents needed for entry into Mexico



GREAT LOCATION! Just minutes to Central Bay sailing.
GREAT STAFF!
GREAT RATES! Starting at \$6.02/foot!
MARINA GREEN with picnic/BBQ areas and Bay Trail access.
HOME OF THE SIERRA POINT YACHT CLUB



From Hwy 101, take the Sierra Point Pkwy exit and follow the signs to the marina.

400 Sierra Point Parkway
 Brisbane, CA 94005

www.ci.brisbane.ca.us

(650) 583-6975

harbormaster@ci.brisbane.ca.us

WINDEX INNOVATION

WINDEX 15

with Bird-Proof Spike!

Why Windex 15 is the choice for most sailors:

- 15" wind vane (38 cm)
- Sapphire suspension bearing
- Adjustable tacking arms with tabs
- Vane and tabs feature reflectors for high visibility day and night.
- Weighs just 3.9 ounces (111 grams)
- Stands 12.75" tall (32 cm)
- Bird-proof spike extends another 10" (24 cm) above vane to discourage birds from landing.



Great Stocking Stuffer!

The versatile J-Base can be purchased for Windex 15 to allow top or side mounting.



Contact us for your FREE copy of the latest catalog from



Davis Instruments 3465 Diablo Ave., Hayward, CA 94545 USA
 Phone 800-678-3669 • Fax 510-670-0589 • Email info@davisnet.com

www.davisnet.com

HERITAGE MARINE INSURANCE

SPECIALISTS

Your best source of insurance, tailored to your needs and competitively priced, for your boat or yacht, marine contractor liability, yacht club, boat yards, and boat builders/restorers

We Insure:

Sail or Power ♦ Classic or Contemporary
 Fiberglass ♦ Aluminum ♦ Steel ♦ Wood

At Heritage Marine Insurance you will find knowledgeable insurance professionals who provide superior service and the finest coverage available today.

To be sure you're getting the best insurance value please contact us for a quote.

www.heritagemarineinsurance.com

800-959-3047

Fax 860-572-5919

info@heritagemarineinsurance.com

Classic Program available exclusively through:



© 2014 Insurance policies issued by ACE Recreational Marine Insurance are underwritten by the insurance companies of ACE Group.

SAUSALITO

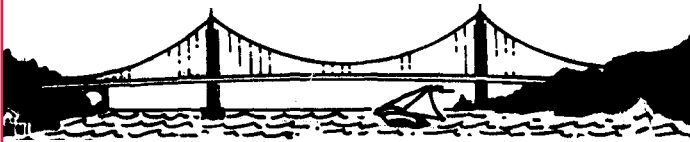

LIST MARINE INC.

- Full service engine shop
- We service all makes
- Dockside facilities
- Mobile service trucks

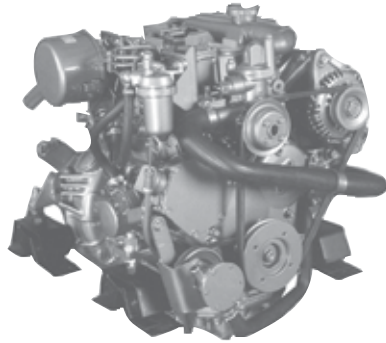

P.O. BOX 2008 / 69 LIBERTY SHIP WAY • SAUSALITO, CA 94966
Adjacent to Schoonmaker Pt. Marina

415•332•5478

www.listmarine.com

LETTERS

by boat. I have not visited Mexico by boat since 2000, but I wonder if you can clarify something. In the past, I don't recall having to complete the submission of an electronic Crew List as suggested by the Mexico government website at bit.ly/MXCrewList.

From my reading of your article on Mexican paperwork, I think what you are saying is that an advance electronic Crew List is only needed if you plan to stop along the coast before clearing in at a port of entry such as Cabo San Lucas. I'm planning to shoot straight down to Cabo and clear in there. Am I correct that I do not need to file an electronic list of passengers?

I would never hold anything you say against you if you turn out to be wrong, as I understand how complicated these rules can be and how they are constantly in flux. That said, what is your understanding of this question?

Jordan Bigel
Queen Jane, Shannon 50
Marina del Rey

Jordan — The things that drive us nuts about rules and regulations for arriving in Mexico by boat are as follows: 1) There is no single source where the requirements are clearly stated. 2) You can't be sure that anyone, including the various officials, knows the law. 3) The rules and regulations are often changed without any warning. And, 4) you never know what paperwork any given official is going to think is important.

Thanks to the Mexican IRS's irrational impounding of 338 foreign-owned boats last November, most folks headed south in the Ha-Ha were a little freaked about getting all their paperwork precisely correct. This, of course, was impossible, as the websites often didn't work, in many cases wouldn't accept the requested information, and often made little or no sense at all. As a result, quite a few Ha-Ha people just said 'screw it', and headed south as everyone used to — without a TIP (Temporary Import Permit), without a Crew List, and without electronically submitting a Crew List in advance. Based on everything we've heard since, having paperwork with errors didn't create any major problems, nor did not having any paperwork at all. It was like the old days in Cabo.

Where things got a little hinky is when skippers, for whatever reason, didn't check into Mexico until after Cabo San Lucas. Several such boats arrived in La Paz, where immigration officials said they knew nothing about the prepaid temporary nautical visas that had been obtained online and supposedly could be turned in for regular visas at no extra cost. After Immigration in La Paz called Immigration in Mexico City, all was well. At least one other boat showed up at Mazatlan and tried to clear in with Immigration using the pre-paid temporary visas for mariners. "The officials did not honor our pre-paid tourist visa receipt," they wrote, "and said they didn't know what we were talking about. They chewed us out and made us spend \$22 each to get regular tourist visas." Once again, no big deal. To be fair, since almost nobody goes past Cabo without checking into Mexico, we doubt officials in Mexico City had alerted La Paz or Mazatlan Immigration to the existence of the temporary nautical visas. To additionally be fair, the Mazatlan port captain was said to be extremely pleasant.

Things got hinky for another boat that didn't check in until Puerto Vallarta. We'll let them tell about it in the next letter. The bottom line was that no matter if you showed up in Cabo with a lot of paperwork, screwed up as it might be, or no paperwork at all, neither the Port Captain nor Immigration got bent out of shape. It was like the old days.

Adding to the official fun were spotty Agricultural and Health

Safe and Dry



888-437-5512

nfm@newfoundmetals.com

NewFoundMetals.com



DROP YOUR RIG NOW

(So it doesn't drop next summer)

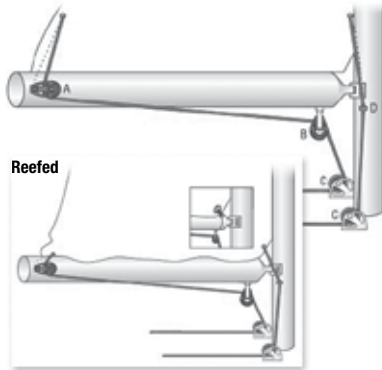

The days are shorter, cooler and perfect for rigging:

- **repair**
- **replacement**
- **upgrades**

HAPPY HOLIDAYS
FROM EASOM RIGGING
 (Gift Certificates Available)

It will be sunny, warm and windy sailing before you know it. Call to reserve space today!



Easom Racing and Rigging

1230 Brickyard Cove Rd., Suite 102
Point Richmond, CA 94801

(510) 232-SAIL (7245)

www.easomrigging.com

RICHARDSON BAY MARINA formerly Kappas Marina

MODERN FACILITIES IN A WELL-PROTECTED HARBOR

Concrete Dock System

Well Maintained Facilities

Beautiful Surroundings

- DEEP WATER BERTHS: BASIN AND CHANNEL DREDGED
- CARD KEY SECURITY SYSTEM
- DOCK CARTS
- PUMP OUT STATION
- AMPLE PARKING
- CLEAN SHOWER AND TOILET FACILITIES
- WITHIN WALKING DISTANCE: MARKET/DELI, LAUNDROMAT, RESTAURANT
- AT EACH BERTH: LARGE STORAGE BOX, METERED ELECTRICITY, PHONE HOOKUPS, WATER

BERTH YOUR BOAT IN SAUSALITO

**415 332-5510 www.richardsonbaymarina.com
 100 Gate Six Road, Sausalito • Fax 415 332-5812**

Head North for the Holidays!

The latest sailing gear and accessories from North Sails.



NORTH SAILS GEAR

www.northsailsgear.com

1-800-SAIL-123, ext. 653

LETTERS

inspections. Profligate got inspected at the dock in Cabo, where we were told that we couldn't have any fruit or meat — although it wasn't clear if it mattered if the meat was sealed in plastic bags. The friendly inspectors took no meat, but they did take a bunch of fruit, but not the grapes. Someone later came back to confiscate the grapes, but completely overlooked a conspicuous net full of oranges and lemons. Many boats were not inspected by Agriculture at all.

Officials in La Paz have always had a thing about health inspections/certificates, and over the years have often required cruisers clearing out of Mexico to pay for expensive health inspections for their crew and/or their boats. This is why you never want to clear out of Mexico from La Paz. Shelley Ward, commodore of the Club Cruceros de La Paz, reports that when Ha-Ha boats got to La Paz, they had to go through some kind of health inspection. "The new inspection supposedly had something to do with Ebola," writes Ward, "which seems kind of silly." No kidding. But once again, it wasn't a big deal.

We want to emphasize that we haven't heard of any major paperwork problems, which is our long way of saying check in at Cabo without an advance electronic warning and you probably won't have any problems.

↑↓ THE RULES JUST CHANGED A COUPLE OF HOURS AGO

When we got to La Cruz, we got fuel, then checked into our slip at the marina, and then we walked over to the port captain. He said we needed to check into Mexico at Nuevo Vallarta's Port Captain's office, or the one in Puerto Vallarta, and said we had to take our boat and all our crew with us. When we got to Nuevo Vallarta, the port captain said no, we had to go to Puerto Vallarta, and hail the port captain on 16 to get instructions on where to tie up to get our paperwork done. We couldn't raise the port captain on VHF — ! — so we tied up to the 15-ft-high concrete commercial dock, next to a 500-ft-long, 20-story cruise ship.

The official at the P.V. Port Captain's office said the rules had changed at 3 p.m. that day, and thus he had to get authority from his boss before he could do anything for us. He also thought we should first go to API and pay for tying to the commercial dock. Eventually we were asked to move from our spot on that dock to allow a local tour boat to disembark her passengers, and had to motor around the turning basin waiting for the authorities to arrive and inspect our boat.

Finally, three of the four necessary officials arrived, and we returned to the dock. They climbed aboard and efficiently handled our paperwork in about 20 minutes. Immigration never showed up.

The next day Immigration emailed us asking for our Crew List. We replied with the same Microsoft Excel spreadsheet we'd supplied online in San Diego. When they received it, they replied, "Okay, come to the office, we're open until 1600." When we got there at 1300, the office was closed, but after some 'splainin, we got in and all was good — until they discovered our receipts were for a clearance at Cabo. They had to get approval from Guadalajara on that one. This eventually came, and now we're all legal. And we know we're in Mexico.

Anonymous
California

Readers — Once again, this is a case of a boat from California checking in somewhere long past the common ports of entry of Ensenada or Cabo. Had they checked into Mexico at either of those places, they wouldn't have had any problem instead of just a minor one.

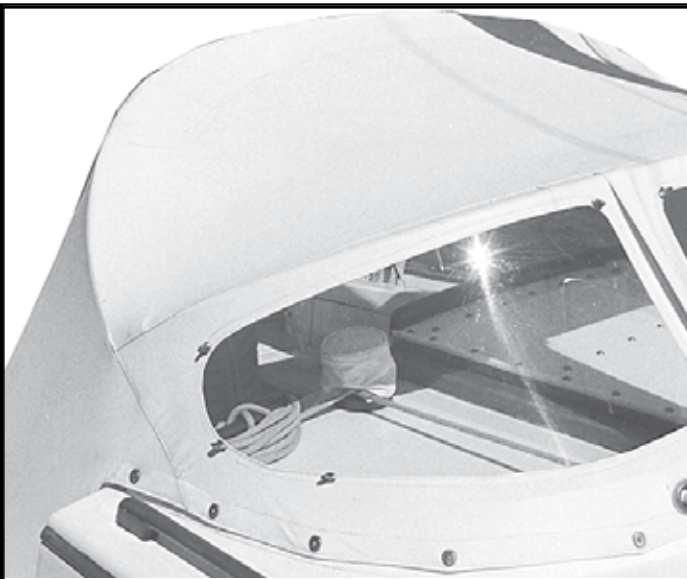

*Patron Saint of Sailors.....St. Nicholas
Patron Saint of Canvas.....St.Ar buck*



STARBUCK CANVAS WORKS
415•332•2509

67 Liberty Ship Way, Sausalito, CA 94965
saintar buck@sonic.net
"Unless you just don't care."

Easy Shoreside Travel

ZAPPY PRO FLEX 500

Compact
Easy Storage
Convenient



- 500 W Motor
- 48 V System
- Off Road Tires
- Battery Type: Sealed Lead Acid
- Charger: 100V-240V UL Approved
- Charging Time: 4-6 Hours
- Max Speed: up to 15 mph
- Single Charge: up to 15 mph
- Max. Capacity: 275 lbs
- Net Weight: 128 lbs

O'Connell Electric
Scooters

2363 Mariner Square Drive, Suite 149 • Alameda, CA 94501
(510) 865-7255 • oconnell1@earthlink.net



FROM OUR FAMILY TO YOURS...
DEVERY, KURTIS, JAVIER, LUIS,
MAX, ABBY, STEPHANIE, & CAPTAIN JACK SPARROW



OWL HARBOR MARINA IN THE DELTA

We are adding a beautiful new facility with offices, restrooms, showers, laundry, banquet room and multi-purpose room.

- Guests & Yacht Clubs Welcome
- Private Gated Marina
- Heated Restrooms & Showers
- Picnic Areas, BBQs, Hammocks
- Horseshoes, Bikes, Gardens, Chickens
- WiFi, Parking at Every Dock
- Valet In/Slip Pump Outs

916-777-6055

WWW.OWLHARBOR.COM

WE LOOK FORWARD TO SEEING YOU!

2015 MODELS ARE IN!

More Fun. Less Fuel.

Unsurpassed Fuel Economy

- Quiet, 4-stroke technology
- Transistorized pointless ignition
- Ideal for sailboats, small tenders



POWERED BY

**HONDA
MARINE**

© 2013 American Honda Motor Co., Inc.
 Always wear a personal flotation device while boating and read your owner's manual.
 5-year warranty standard on all new Honda outboard engines purchased.
 Check with participating dealers for complete details.

Outboard Motor Shop
Where the professionals shop!

(510) 533-9290

www.outboardmotorshop.com

333 Kennedy St., Oakland, CA 94606 • Fax 510-533-3374



THE NELSON CAP

CAMWRAP* thanks *Latitude 38* readers and customers for speaking up about our popular Nelson Cap:

- ☞ "It's so comfortable."
- ☞ "...classy..."
- ☞ "There's nothing fussy or pretentious about The Nelson."
- ☞ "100% wool – dark navy Melton cloth..."
- ☞ "It keeps my head warm!"
- ☞ "...my wife loves it."
- ☞ "Och Aye, and it's made in bonnie Scotland!"



For more information, including retail stockists, call

(800) 353-9004

or email: camwrap@birch.net

*Since 1972, Camwrap has supplied America's top universities with the traditional British wool flannel school scarf, or Campus Wrap.

Defender®

Marine Outfitter of Choice Since 1938

THE BRANDS YOU WANT AND TRUST IN STOCK FOR LESS!



ResQLink+ PLB

- Lightweight, buoyant and small!
- Built-in 406 MHz Signal, GPS Positioning and Super Bright LED Strobe

Item 550429 • List \$325

ONLY
\$269⁹⁹



GlobalFix PRO Cat II GPS EPIRB

- 406 MHz signal and 121.5 MHz homing capability
- Internal 16 Channel GPS
- Highly Visible LED Strobe

Item 550190 • List \$914

ONLY
\$469⁹⁹

Visit www.defender.com for our current ACR promotions



defender.com ★ 800-628-8225

FREE
Catalog!

Most orders placed by 4:30PM ET ship the same day!
We are not required to collect sales tax on orders shipped outside of CT!

LETTERS

↑↓ THE FICKLE FINGER OF FATE

I'm from New Jersey and hardly a prude when it comes to language or sharing my feelings. However, I'm becoming distressed by the public display of bad language, poor taste, and rude behavior that is so common these days. On the other hand, I say that 'anything goes' in private.

Perhaps my attitude is colored by my wife's reaction while outside the home when she witnesses questionable behavior.



LATITUDE/ANDY

It was all part of their costume for the Ha-Ha Kickoff Party. "We're from New Zealand, but we're posing as Aussies!"

She has advanced early-onset Alzheimer's, and I've been her full-time care-taker for over five years. She reacts very negatively to rude public actions, and I'm surprised that a publication such as *Latitude* would feel the need to publish the photo of a couple 'giving the finger' on a family website. Where do we draw the line?

By the way, I read *Latitude 38* and *Lectronic Latitude* for information

in advance of buying a liveaboard boat after my wife passes. Then I'll be cruising until my scrotum reaches my ankles. Told you I'm from Jersey! I promise to behave in public (only) when I join the group to Cabo in a few years.

Bill Baker
New Jersey

Bill — The couple flipping the bird in the photo weren't doing it in public, they were doing it in costume, and in character, during the Ha-Ha Halloween Kick-Off Party. In real life, he wouldn't be going around with a mustache on his chin, and we bet she wouldn't have that cigarette in her mouth. Halloween is the time when people get to indulge in their naughty alter egos, from being pirates — who were usually bloodthirsty characters — to women of suspect virtue. Therapists tell us there are times when it's healthy to be silly. One of the times is the Ha-Ha Kick-Off Party; another is the group dancing party at Squid Roe in Cabo.

Until your what reaches your ankles? If this wasn't such a stellar example of hypocrisy and way too much information (WTMI), it's where we would have drawn the line. Public decency demands that both males and females of a certain age wear Speedos to keep their private body parts from escaping the confines of looser swimwear.

By the way, our mother was also a victim of early-onset Alzheimer's. Like you, our father was a saint in caring for her for many years. You have our respect. We wish you the very best when your time comes to go cruising, for you surely deserve it.

↑↓ IN ADVANCE OF VANCE

In case you haven't seen this, I've attached a NOAA plot of the path of Hurricane Vance created this morning, Sunday, November 1 at 7 a.m. From the looks of things, Cabo could get hit really badly just as the Baja Ha-Ha fleet is arriving. As I'm sure you're aware, being on the eastern side of a hurricane in the northern hemisphere exposes one to the highest wind speed — and that's what it looks like will happen based on this projection.

Mark Novak
Betty Jane, Hans Christian 43 Ketch
Santa Cruz

Official
Sponsor

2014
BAJA
HA-HA

MEXICO CRUISERS STEP ONE:

MAKE A RESERVATION AT MARINA EL CID
FIVE STARS FULL SERVICE MARINA
MAZATLAN

*You'll get such a great 'impression'
from our marina services and beaches,
you may never leave!*



El Cid
RESORTS
mazatlan - cozumel - cancan

www.elcidmarinas.com

011-52 (669) 916-3468

marinaelcidmazatlan@elcid.com.mx

Build your own racing yacht!

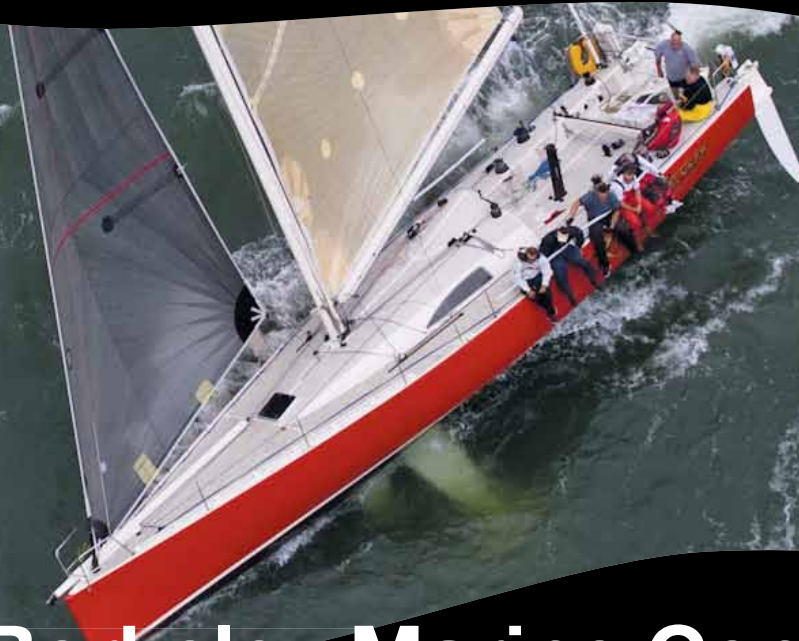

Berkeley Marine Center

www.berkeleymarine.com • 510-843-8195



- Awarded five-star outstanding club of the year by PICYA.
- New! Military membership available to all active men and women of the armed forces. Email or call us for more information on how we are celebrating our brave men and women.
- Lighted Yacht Parade Saturday, December 6. Come join us for the largest celebration in the Estuary!
- Join us for an amazing dinner any Friday prepared by our executive chef and staff!

For more information contact:

membership@oaklandyachtclub.com • (510) 522-6868



Oakland Yacht Club
on the Estuary in Alameda

Celebrating 100 Years of Boating Tradition

(510) 522-6868 www.oaklandyachtclub.com

STERLING ASSOCIATES

WE WANT YOUR BOAT LOAN

WEST COAST REPRESENTATIVE
Max Salvater 888-898-2476
max@boatbankerusa.com

HIT THE WATER WITH A GREAT RATE!
AS LOW AS!
3.65% APR

Happy Holidays!

Visit us at...
www.boatbanker.com

Captain's License

Maritime  Institute

Captian OUPV - 6 Pack/100 Ton

San Diego, CA - December 1 - 12
Long Beach, CA - December 1 - 12

Endorsements - Sailing

San Diego, CA - December 4
Long Beach, CA - December 4

Endorsements - Towing

San Diego, CA - December 2
Long Beach, CA - December 2

STCW Basic Safety Training

San Diego, CA - December 15 - 19

Radar Observer - Unlimited

San Rafael, CA - December 1 - 5

Call Today!!! Toll Free: 888-262-8020

www.MaritimeInstitute.com

LETTERS

Readers — The Grand Poobah received several well-intended email weather warnings such as the one above shortly after the end of the first leg of this year's Baja Ha-Ha, with Hurricane



NOAA

Hurricane Vance caused the first-ever postponement of a Ha-Ha leg.

Vance vaguely threatening southern Baja. Some readers may be interested in the Poobah's line of reasoning as he adapted to the weather threat.

As one might expect, the Poobah had been monitoring the weather carefully all during the first leg. Thanks to a decent AT&T data connection at Turtle Bay, he awoke several times in the middle of each night to get the Vance updates from the National Hurricane Center, which tends to be sluggish to forecast storms, and from Passage Weather, which tends to forecast storms farther in advance. The Poobah also consulted with Commander's Weather, the weather forecast provider for the Ha-Ha, several times a day, and because of the unusual situation, several other professional weather routers.

For the Poobah, Vance was an annoying storm for two reasons: First, he took forever to get his act together, and second, it was very unlikely he would hit southern Baja at all. But with tropical storms and hurricanes, 'very unlikely' is not an adequate safety margin.

The second leg of the Ha-Ha was slated to leave for 240-mile distant Bahia Santa Maria on Saturday, November 1. At that time the National Hurricane Center was giving Bahia Santa Maria, which is 175 miles north of Cabo, a zero chance of being affected by Vance. However, the extreme edge of the National Hurricane Center's much more conservative '1-2-3 Rule for Mariners' did just barely include Bahia Santa Maria.

When Oliver from Commander's Weather advised, "I don't believe it's safe to go south," that was it. The Poobah announced that, for the first time ever, the Ha-Ha fleet had to hold up because of a weather threat. Oliver's advice was later confirmed by Rich Shema of www.weatherguy.com.

On Sunday, November 2, the weather picture wasn't much clearer. Bahia Santa Maria was still in the ultra-conservative 'Mariner's 1-2-3 Zone' for Vance, and there were forecasts of wind to 30 knots from a northeast front with possible gusts to 35 knots on the way to Bahia Santa Maria.

The Poobah presented all the weather information to the fleet, then polled each skipper on his/her thoughts. A little less than one-third of the fleet were in favor of continuing on, while about two-thirds said they preferred to wait — even though this would put the event behind schedule and jeopardize reservations many of the crews had to fly home from Cabo. But hey, you can't sail toward a tropical storm threat just to keep a party schedule. The Ha-Ha was thus postponed for a second day, despite the fact it meant the Poobah had to call the beach party hosts for Bahia Santa Maria and call off that event, and that the schedule would also be thrown off in Cabo.

After the Poobah announced there would be a delay, Harry Hazzard of the Beneteau 51 Distant Drum, who has done more Ha-Ha's than anyone but the Poobah, Assistant Poobah and Ha-Ha Chief of Security, announced that he was going to continue south and wanted to know if anybody else wanted to join him. Although there would be a lot of flip-flopping of plans, about 40 boats decided they would go south on that day in what became known as the 'Braveheart' group.

Stem To Stern LLC

(510) 681-3831

stemtosternsf.com

- Not going down to the boat much now?
- Need to repair from last season?
- Upgrading for next season?
- Yard period project?
- Storm check up?
- Engine start up?
- Wash?
- Dive?



Lower rates apply for off season and winter projects. (Dec-Feb)

We Take the Work Out of Owning a Boat

**FREE FIRST MONTH'S RENT FOR
30' • 32' • 40' SLIPS!**

LOCH LOMOND MARINA



**Free Pump Out Station • Modern Launch Ramp
Guest Slips Available • Marine Mechanical Boat Repair
Arena Yacht Sales • Andy's Local Market • Bait Shop
Land or Sea Canvas • Windjammer Yacht Sales • Loch Lomond Yacht Club**

110 Loch Lomond Drive, San Rafael, CA 94901

Phone: (415) 454-7228 • Fax: (415) 454-6154

www.lochlomondmarina.com

Harbor Master – Pat Lopez • pat@lochlomondmarina.com

Water. Anywhere.



Up to 40 gallons of fresh water per hour

The world's first
truly portable
powered desalinator.

www.rainmandesal.com

Authorized Dealer
Kevin Horne: (949) 209-7777

SAN DIEGO'S RIGGING CENTER

since 1983



Proudly serving for over 30+ years

Safe, cost effective,
professional rigging solutions.

**We'll get you ready for your next
sailing adventure!**

Design consulting • Commissioning
Refits • Custom line and hardware

Official
Sponsor
2014
BAJA
HA-HA

WE SHIP
RIGGING
WORLDWIDE

2805 Cañon St., San Diego CA 92106

619.226.1252

www.pacificoffshorerigging.com

ULTRA SMALL CABIN AND WATER HEATER

DEPENDABLE COMFORT

Be comfortable all year round with a quiet, reliable Webasto hot water heating system. Can be linked to pre-heat an engine and provide all the hot water you'll need in the galley or for showers.

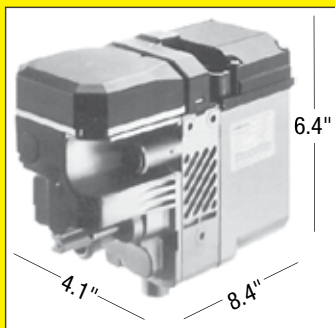

Webasto

CERAMIC IGNITION SYSTEM

- Heat output 17,200 btu/hr (5kw)
- Fuel Consumption .18 gal/hr
- Power Consumption 32 w
- Weight 6.4 lbs

CALL FOR MORE INFORMATION



SWEDISH MARINE

1150 BRICKYARD COVE RD., SUITE B6
PT. RICHMOND, CA 94801 (510) 234-9566

OPEQUIMAR

MARINE CENTER CENTRO MARINO

Our Experience Makes the Difference



High velocity pump fuel dock, 46 gals./min. • Travelift: 88 tons, 100' length, 23' beam
Dry storage for vessels up to 300' • VHF radio ch. 68 • 24-hour security • Dock rentals
Sales & rent of used & new boats • Full service boatyard • Do-it-yourselfers welcome

The Most Complete Marine Center Open 365 Days

Puerto Vallarta, Jal. Mexico / Tel: (322) 221-1800
www.opequimar.com / info@opequimar.com

LETTERS

The Poobah had to make it clear to each skipper who continued on that they were dropping out of the Ha-Ha, but could immediately be reinstated when the Ha-Ha fleet caught up with them, hopefully in Bahia Santa Maria. At this point, several of the Braveheart fleet said they were going to Mag Bay, a little farther south of Bahia Santa Maria, as it would provide better protection in the event they were hit by tropical storm force winds. As it turned out, only one boat went to Mag Bay, and ended up lonesome.

By Monday, November 3, members of the Ha-Ha were restless to move on, despite the fact that Bahia Santa Maria was still included in the 'Mariners 1-2-3 Zone'. Having monitored various weather sources through the night on his iPhone, the Poobah noticed that there was no threat of even the edges of tropical storm winds from Vance getting north of Bahia Santa Maria. After confirming this with two independent weather routers, the course of action became clear — start the second leg immediately and, depending on what Vance did, hold the fleet up in one of several anchorages well north of Bahia Santa Maria. So the Ha-Ha fleet set out in a mild northwesterly, which, right about sundown, abruptly switched to the northeast and would blow in the low to mid-20s for about 24 hours — exactly as was forecast. It was perhaps the most consistently windy leg in any Ha-Ha to date, and provided for spirited sailing.

By the next morning, Vance had, as everybody had forecast, moved to the east and begun to fizzle. This meant everyone could continue on to Bahia Santa Maria without any concern.

Thanks to Bob Hoyt of Mag Bay Outfitters in Lopez Mateo, the Poobah was able to revive the beach party at Bahia Santa Maria, one of the highlights of many Ha-Ha's, although the stay at the beautiful bay had to be cut short by one day.

As it turned out, Vance never really threatened Cabo, and pissed out as a rapidly fading tropical storm halfway between Cabo and Puerto Vallarta, about 140 miles to the southeast of Cabo. The closest Vance ever came to the Ha-Ha fleet was about 375 miles, at which time it was already rapidly heading in the opposite direction and rapidly falling apart. So despite Vance, it's still true that no hurricane or tropical storm has ever crossed the Ha-Ha path. Nonetheless, the Poobah is hoping for a somewhat cooler Eastern Pacific next year to end threats of tropical storms a little earlier.

Perhaps the most significant thing is how good weather forecasting has become. Had it been just 10 to 15 years ago, the information on which to base decisions wouldn't have been available or as good.

↑↓ DIFFICULTY IN CONTACTING SATPHONE SUBSCRIBERS

I first want to thank *Latitude* for including my 'Who Is Responsible For Satphone Continuity' letter in the November issue. I am happy to assist in bringing this information to light, and hopefully assist users in their understanding of how the current satellite phone systems operate and what things to look out for. We've had many conversations with boatowners at the last few boat shows regarding all of this, and know that this is a hot topic in light of the *Rebel Heart* incident that kicked off all the publicity.

In response to my November letter, the *Latitude* editor replied as follows: "Everybody knows that satphones are frequently relied upon in life-and-death situations, and that 99% of the end users can't remember the expiration date of their plan — let alone the very fine details of whatever plan their particular retailer talked them into. So we think it's incumbent upon the vendor who sells the time to alert the end user a month in advance of the expiration of their plan and/or when 90% of their usage is up. If AT&T can do it by MTS

Yachtfinders/Windseakers

in the heart of
San Diego's boating community



A LEADER IN
BROKERAGE
SALES
ON THE
WEST COAST!



2330 Shelter Island Dr. # 207, San Diego, CA 92106

info@yachtfinders.biz

www.yachtfinders.biz

(619) 224-2349

Toll Free (866) 341-6189



70' SANTA CRUZ, '87 \$299,000
Santa Cruz 70s are remarkably easy to sail and are the best big boat for a family and friends to race - and they keep winning, too.



45' COLUMBIA CC MS '73 \$43,500
She has been converted to a cutter rig with the addition of a bowsprit, giving her a much more flexible sail plan and perfect balance.



42' VALIANT '04 \$299,000
This extremely clean, well equipped, low hour Valiant 42, *Midnight Snack*, has been equipped by a very knowledgeable captain.



41' DOWNEASTER PH '80 \$80,000
A classic with an unusual inside helm/pilothouse configuration. There are many upgrades throughout this sturdy vessel.



41' NEWPORT '71 \$29,000
Riot is a great sailing boat. Coast Guard safety inspection annually. Strong, stable, fast and in good mechanical and structural condition.



39' CAL '78 \$59,900
Obsession, a South Pacific vet, is a rare opportunity for those looking for a fast circumnavigator and racer in one package.



36' CATALINA '83 \$39,500
New 5/2014 Quantum main and genoa on this excellent coastal cruiser or liveaboard which has one of the best family layouts ever.



36' MARINER '80 \$48,900
Built by the Mariner Yacht Company in New Hampshire. A Peter Canning design, she is sea kindly and responsive. Take a look!



35' FUJI '77 \$39,500
John Alden, Inc is known for designing yachts with windward performance and nice crafted woodwork below. She deserves a look!



34' C&C+ '81 \$39,995
Current owner has had her for 14 years and has taken very good care of her. All wood sparkles. Deck and nonskid done recently.

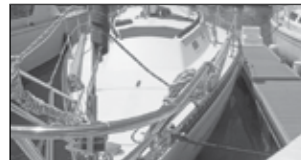

32' ISLANDER '77 \$22,000
Islander 32s are very roomy for their length and have comfortable accommodations for living aboard. Start a new adventure now!



30' CATALINA, '86 \$29,500
A very clean Catalina 30 that's well priced and in excellent condition. Continually maintained, she shows her seller's pride of ownership.

License #0E32738

TWIN RIVERS MARINE INSURANCE

AGENCY, INC.
"Your Marine Insurance Specialists"

7 Marina Plaza • Antioch, CA 94509 • At The Antioch Marina
Latitude 38° 01' 10" N - Longitude 121° 49' 10" W - Buoy 4 Red - On the San Joaquin River

- Shop Your Renewal & Save - Flexible Survey Requirements
- Broad Navigation Areas • Liveaboards • Classic Yacht Coverage
- Agreed Value Policies • Fuel Spill Liability • Get a Quote Online



Your Twin Rivers Policy Comes With an Agent

West Coast • Hawaii • Mexico • East Coast

Marine Insurance made simple, affordable and effective.

www.BoatInsuranceOnly.com (800) 259-5701

Years of unbeatable experience to match your needs to the right product.



Commercial Marine Insurance • CALL DOUG for a QUOTE

- Marinas/Resorts
- Dealers/Brokers
- Charter/Tour/Fishing Vessels
- Boat Builders
- Marine Products Manufacturers
- Yacht Clubs
- Vessel Repair Facilities
- Rental Vessels/Workboats
- Marine Contractors
- Wholesalers & Distributors

Doug Rader Your Commercial Marine Specialist • Direct 209-334-2858

Members:

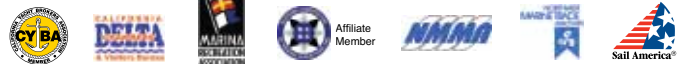

ONCE A SAIL, FOREVER A SEA BAG

SEA BAGS

★ MAINE ★

WE TRADE BAGS FOR SAILS

Recycle your sail with us and get a **FREE** Sea Bag!

Totes, gifts, wine bags & accessories, all made in Maine from recycled sails.



Email Christa@seabags.com to learn more.

1-888-210-4244 • SEABAGS.COM

Your Boat
is a thing of beauty.
We want to keep it that way.



We combine communication, innovation, experience, and passion to create the best looking and most durable covers possible.

- Classic dodgers and biminis
- Drop-top folding dodgers
- Custom canvas for sailboats

560 W. Cutting Blvd., #2
Richmond, CA 94804
Inside the KKMI boatyard

(510) 234-4400

Quality
Yacht
Canvas

FULL SERVICE MOBILE RIGGING

A SELECTION OF OUR SERVICES:

Standing Rigging • Running Rigging
Furlers • Lifelines • Repair — All at Your Slip!

We can also do full rig replacement.

Competitive Rates
More than 20 Years Experience
Firm Labor Quotes on Most Projects



Alameda

yachtcheck@yahoo.com

(510) 815-4420

LETTERS

and email with their cellphone service, why can't satellite time providers do the same? Besides, isn't it in the best interest of the vendor to do this? It gives them the opportunity to sell more time and keep from losing a customer to a competitor."

I agree that most satellite phone users do not keep very close tabs on the status of their accounts. In the case of Iridium prepaid plans — the primary airtime plan being faulted in this discussion for mariners' being unable to use their phones because time ran out or expired — keep the following in mind:

1) Each time you make a voice call, you get a voice prompt with your current balance and expiration date before the call is completed.

2) Prepaid plans do not require monthly billings that might keep the user up-to-date.

3) Prepaid plans do not autorenew unless specifically requested by the end user, where an agreement must be in place between the customer and the vendor. Keep in mind that the dealer is responsible for the airtime. If they were to auto-reload a customer's account without the customer's fully agreeing to it, the customer could refuse to pay. Because these are prepaid minutes, the minutes cannot be retracted, so the dealer would be left on the hook.

Also keep in mind that satellite phone users are typically remote. This means that in most cases they are not getting regular email, phone calls or physical mail. Nor, in many cases, do they want to. So getting in touch with them can be rather difficult. Thus it is not quite fair to put all of this burden on the airtime vendor, but as you can see, it is important to pick your vendor carefully.

As an airtime vendor, we at OCENS truly understand why customers have satellite phones. And we understand the nature of how and where these devices are typically used. This knowledge is evident in all the products and services we both design and offer. Our goal is to help customers to get the most out of their equipment and service, so we make every effort to alert the customer as to the status of their accounts — even prepaid accounts. We send out a number of notices when their balances get low or expiration dates get near. We send alerts via the email address provided by the customer, and then again via SMS directly to the phones. We want to not only keep our customers, but also keep them safe and happy.

Jeff Thomassen
OCENS

Des Moines, Washington

Jeff — If you use email and SMS alerts to customers to alert them that their plan — even if it's a prepaid plan — is about to expire, we think you're doing everything that you legally and ethically should be obligated to do. We think that what you're doing should be an industry-wide requirement.

When Profligate crewman Fin Bevin does the Ha-Ha, he always brings his Iridium/OCENS combo to produce GRIB files on the computer screen. It's one of several great ways to get weather when far offshore.

In a typical month, we receive a tremendous volume of letters. So if yours hasn't appeared, don't give up hope.

We welcome all letters that are of interest to sailors. Please include your name, your boat's name, hailing port and, if possible, a way to contact you for clarifications.

By far the best way to send letters is to email them to richard@latitude38.com. You can also mail them to 15 Locust, Mill Valley, CA, 94941, or fax them to (415) 383-5816.

It's Beautiful... It's Private... It's Home



Making boating easier – and more fun! – is what Oyster Cove is all about. That's why we rate number one with many Bay Area boaters. Oyster Cove is an exclusive yet reasonable facility of 219 berths, accommodating pleasurecraft in slips up to 60-ft long. **Oyster Cove is the private Peninsula marina closest to bluewater boating.** No other private Peninsula marina is better situated or offers nicer, fresher surroundings.

OYSTER COVE MARINA

385 OYSTER POINT BOULEVARD #8A,
SOUTH SAN FRANCISCO

(650) 952-5540

- Berths 30 feet to 60 feet
- Double Finger Concrete Slips
- Five Minutes from SFO
- Close to Mass Transit
- Heated Dressing Rooms & Showers
- Laundry Room
- Nightly Security Patrol
- Complimentary Ice

www.oystercovemarina.net



Serving the Bay Area
Since 1986

Seashine

Service of the Month

POLISH & WAX

A buffed boat not only looks great,
but will hold its shine and value for longer!
Call for a buff!

ADDITIONAL SERVICES

Interior Cleaning • Detailing • Wash Downs
Maintenance • Carpet & Cushion Cleaning

Fully Insured & Marina Approved

Call now for a Free Estimate

510 428-2522 or 415 457-6300

www.seashine.net

Season's
Greetings
and
Thank
You
for a
wonderful
2014



We couldn't continue without
your support and patronage.

Best wishes for 2015!

SAL'S

INFLATABLE SERVICES, INC.

PHONE (510) 522-1824 FAX (510) 522-1064

1914 Stanford Street, Alameda, CA 94501
salsinflatables@sbcglobal.net • www.salsinflatableservices.com

SIGHTINGS

dig out your bermuda shorts

If the rumor mill is correct, the 35th America's Cup will be held in Bermuda, not San Diego. Here's the background: On November 5 AC 35 organizers announced that Bermuda would host an AC World Series event for foiling AC45s in October, 2015. Racing will take place on the Great Sound, with team bases and a public race village located on the waterfront in the capital, Hamilton.

That news triggered speculation that Bermuda had won out over San Diego as the location of the AC 35 challenger series and finals

in 2017. It had been announced months earlier that all AC 35 challengers, plus the defender, Oracle Team USA, would be invited to host an ACWS regatta in their home waters — but Bermuda is not a challenger.

Then, on November 20, the America's Cup Event Authority sent an invitation to the media for a press conference on December 2 in New York City, where the choice of

venue between San Diego and Bermuda would be announced.

Less than a day went by before "a person with knowledge of the situation" tipped off the Associated Press that the "tax haven" of Bermuda had been picked over San Diego. Not surprisingly, as soon as AP published the story, it was propagated through sailing blogs, forums and social media sites. However, it remains to be seen how reliable the source is.

If you haven't been following the AC buzz, the 2017 events will be raced in AC62 foiling cats with eight-person crews. As with the run-up to AC 34, next year's AC World Series will serve as a sort of practice event for the hosts, and will include fleet racing.

— chris

embodying the spirit of adventure

The esteemed National Geographic Society has, for the last 10 years, selected candidates for the title of Adventurer of the Year. Candidates are chosen based on "his or her remarkable achievement in exploration, adventure sports, conservation and humanitarianism." According to the Society, this year's honorees "embody the spirit of adventure in diverse ways — an exploratory surfer seeking the world's most remote waves; paragliders pushing the boundaries of their sport; an activist challenging the status quo; filmmakers using art to drive conservation; blind kayakers redefining what's possible; and five other feats."

The "exploratory surfer" who was selected as a candidate is none other than Liz Clark of the Santa Barbara-based Cal 40 *Swell*. We met Liz, now 34, nine years ago just before she took off for Mexico, Central America, the Galapagos, the Society Islands and Kiribati. During the last five or six years she's been mostly sailing singlehanded and often surfing alone in French Polynesia. During the early years of her adventure Liz frequently contributed to *Latitude 38*, and we have a report from her in this month's *Changes*.

While we personally think it's crass and contrary to the very spirit of adventure, the Society encourages readers and interested people to vote — maybe even stuff the ballot box — for the person they think "most embodies the spirit of adventure." It seems to us that you either have the spirit of adventure or you don't, and the spirit of anything is

continued on outside column of next sightings page

what's your

Due to lighter winds, wetter weather and colder temperatures, most West Coast sailors spend much less time on the water during winter than in spring, summer or fall. But that doesn't mean they stop puttering around with their boats.

Winter is a great time to install new gadgetry, sort out rarely visited lockers, and do all sorts of interior upgrades. In addition, some savvy sailors also wait for an appropriate weather window and do a quick haulout. True, temperatures are



BERMUDA TOURISM / ACEA

Rumor has it that Bermuda will be the venue for AC 35 in two years. It is certainly photogenic, but does it have sufficient infrastructure?



For the past decade, surfer and solo sailor Liz Clark has lived a dreamy lifestyle, exploring the South Pacific in search of great surf breaks and new adventures.

SIMON CORNELIO

winter project?

cooler and days are shorter, but some yards give deep discounts on winter haulout fees, rather than see their yard space sit idle.

If you've got an interesting winter project planned — either in your garage, your backyard or in a boatyard — we'd like to hear about it. Email andy@latitude38.com, and if possible, send us a selection of photos also.

Happy puttering!

— andy

liz — continued

something that can't — and shouldn't — be ranked, let alone voted on. What next, the general public being asked to vote for the Buddhist they think best exemplifies the spirit of Zen?

Our objections notwithstanding, the voting ends on January 31, 2015. You can read about all 10 of the candidates by Googling 'National Geographic Adventurers of the Year.' While we hope you vote for our friend Liz for her sake, we also hope you encourage the Society to rethink this contest of 'adventurousness.' In our opinion it would be far better to simply recognize all 10 as being among the more noteworthy adventurers of the year. Thoughts? (Email: richard@latitude38.com)

— richard



SIGHTINGS

volvo update: cape town to abu dhabi

As this issue goes to press, the Volvo Ocean Race's second leg from Cape Town to Abu Dhabi should be nearing its completion. The thrilling first leg and first stopover set an early tone for the race. Racing 6,487 miles from Alicante, Spain, to Cape Town, South Africa, the seven boats entered in this 12th edition of the VOR (formerly the Whitbread Round the World Race) have sailed into a new era with the introduction of one-design boats — that is the big news of the race so far.

After nearly a month at sea, *Abu Dhabi Ocean Racing*, skippered by double-Olympic medalist Ian Walker beat the Franco-Chinese *Team Dongfeng* to the finish line by just 12 minutes to secure the Leg One victory, while simultaneously offering a compelling answer to the pre-race speculation about whether the switch to one-design Volvo 65s was going to be a good thing. With port-starboard crossings well out

continued on outside column of next sightings page

san francisco boat

With the San Francisco Giants on winter break, McCovey Cove will have plenty of room for the second annual Progressive San Francisco Boat Show on January 22-25. Boats on the water will be displayed in the Cove, while land-based exhibits will be located at Pier 48, with plenty of parking nearby.

New boats for sale will include Bene-teaus, Catalinas, Hanses, Sabres, Jean-neaus, J/Boats and Seawind catamarans. A selection of used brokerage boats will be available too.

In addition to booths offering marine products and services, Fred's Shed In-

INSET DAVID RAMOS / VOLVO OCEAN RACE



SPREAD GILLES MARTIN-RAGET / TEAM ALVIMEDICA



show at mccovey cove

teractive Learning Center will provide live demos of hands-on boat projects for do-it-yourselfers, where show-goers can learn how to maintain, repair or upgrade their boats or motors. Sessions are free with the cost of admission to the show.

Besides a full slate of hourly seminars on dry land, the show will also feature Discover Boating's Hands-On Skills Training on-the-water workshops for power, sail and catamarans. A 'Try It Cove' will offer demos of stand-up paddle boards and other small paddle craft.

For info, see www.sfboatshow.com.

— chris



Spread: Skipped by Charlie Enright, the American entry 'Alvimedica' blasts through an ocean swell. **Inset:** The Swedish all-woman team 'SCA', led by Brit Sam Davies, crosses tacks with the Danish entry 'Team Vestas Wind', skippered by Aussie Chris Nicholson.

volvo — continued

to sea, *Team Vestas* luffing *MAPFRE* midway through the leg, and a four-boat battle for victory up until the last 1,000 miles, this edition of the Volvo Ocean Race is quickly becoming the closest and most exciting in race history.

The women on *Team SCA* fired a warning shot across the bows of their competitors when navigator Libby Greenhalgh made a gutsy call to break from the fleet and tack north in the Strait of Gibraltar. Staying in pressure and avoiding adverse current, *SCA* immediately broke

out to a 21-mile lead and was the first boat to enter the Atlantic. The lead was short-lived as was the breeze, however, with the fleet quickly re-compressing. Weak trades offshore and an unformed Azores High prevented the fleet from sailing west into the trades, which created an inshore-grand-prix-style jibing duel right down the Moroccan coast. Finally



MATT KNIGHTON / ABU DHABI OCEAN RACING

A crewman earns his pay aboard 'Abu Dhabi Ocean Racing'. Needless to say, the nine-month around-the-world race will be a wet and wild adventure for every crew.

jibing offshore and toward the Cape Verde Islands, there was a critical tactical moment when deciding where to pass the Cape Verdes. *Abu Dhabi* was one of the four teams that stayed north of the Cape Verdes, and in doing so set themselves up for a westerly crossing of the doldrums.

In theory, crossing the doldrums farther west will provide better breeze, while staying east offers a shorter course to sail. For both *Abu Dhabi* and *Brunel*, with 6-time race vet Bouwe Bekking at the helm, their westerly doldrums crossing paid big dividends, and the pair came out of the doldrums with a healthy 90-mile lead. Several teams temporarily tried different moves in dealing with the South Atlantic's St. Helena High, but in the end it became clear that the only way to deal with it was to simply go around it. Cutting the corner or trying to hook into small lows proved to be a bad call on multiple occasions, causing several teams to lose ground. Despite breaking and replacing a rudder in the North Atlantic and losing a critical padeye necessary when furling spinnakers, *Dongfeng* managed to get south and again regain ground on the leaders in the Southern Ocean.

Once again within sight of their competitors, *Abu Dhabi*, the team of VOR rookies onboard *Dongfeng* kept the hammer down and challenged Ian Walker and his team of seasoned VOR professionals all the way to Cape Town. Making things even more impressive is that *Dongfeng* is sailing with a handful of Chinese sailors on board whose training has brought them up to VOR caliber in less than two years.

Brunel finished third, just a few hours behind *Abu Dhabi* and *Dongfeng*, with *Vestas*, *Alvimedica*, *SCA* and *MAPFRE* all coming in over the next two days. The young Americans on *Alvimedica* sailed a very smart and respectable leg to finish fifth. Although often lacking slightly in boat speed during Leg One, *Alvimedica* should be battling for the podium soon. (In fact they are winning Leg Two as we go to press.)

The big story of this first leg, however, is that the talent-loaded *MAPFRE* trailed the fleet consistently to come in last on the first leg. Things were so bad that two-time Vendée Globe winner and *MAPFRE* watch captain Michel Desjoyeaux, alongside navigator Nicolas Lunven,

continued on outside column of next sightings page

SIGHTINGS

volvo — continued

got the flick and will be replaced before Leg Two.

Learn more about the event and follow the transponder tracks at: www.volvoceanrace.com/en/home.html. There's also a VOR app that can be downloaded for free.

— ronnie simpson

this time she'll go nonstop

Remember Donna Lange? On March 29, 2007, this Oregon-raised, U.S. Virgin Islands-based sailor made nautical history with the completion of a solo circumnavigation, westabout with stops, via the great capes aboard her Southern Cross 28 *Inspired Insanity*. In seven months she intends to set off again, but this time she hopes

to do a *nonstop* lap around the planet. If successful, she won't be the first West Coast woman to do so. That honor went to Vancouver, BC-based single-hander Jeanne Socrates, who finished the trip last year aboard her Najad 380 *Nereida*. But Lange could be the first American woman to complete the circuit nonstop.

In the months before her summer 2015 departure, Lange hopes to raise money not only for her



DONNA LANGE

Next year solo circumnavigator Donna Lange hopes to begin another lap around the planet, this time nonstop. Will she bring the guitar? Oh yeah.

voyage, but to publish a book about her previous travels and release an album of her latest original songs. Yes, Donna is quite an interesting character. A mother of four with 11 grandchildren, she is a nurse by profession, holds a 100-ton Master's License, is a published author, and plays guitar, uke, harmonica and even the steel pan. (Learn more about this remarkable sailor at: www.donnalange.com.)

For us, quoting stats on singlehandlers often feels like stepping into a minefield, but as far as we know, Pat Henry was the first West Coast woman to solo circumnavigate with stops (1997 in the Southern Cross 31 named *Southern Cross*, via Panama), followed the next year by Karen Thorndike, who did it aboard the Rival 36 *Amelia*, via the great capes. For more on West Coast circumnavigators see our master list at www.latitude38.com (under "Circumnavigators").

Among all female solo circumnavigators, the incredible Ellen MacArthur still holds the fastest time by a female in a monohull: 94d, 4h, 25m, set in the 2001 Vendée Globe. Four years later, she broke the existing overall solo record aboard the massive 75-ft trimaran *B&Q/Castorama*, averaging 15.9 knots! Her time: 71d, 14h, 18m. Needless to say, Ellen didn't have a lot of time for leisure pastimes such as plucking the guitar or writing songs on that trip. In fact, she claims she never got more than 20 minutes' sleep at any one time the whole way around.

— andy

small boat legend goes big

If you're a fan of small boat voyaging, you undoubtedly know the name Serge Testa. Twenty-seven years ago this former Bay Area sailor set a world record that remains unbroken today for circumnavigating in a 12-ft boat. Yes, 12, no typo. Today, however, he and his wife Robin are going big.

Now living in Australia, in April 2013 they became enamored with

continued on outside column of next sightings page

where is brooks

Over the past few years there's been a lot of talk about keeping kids interested in sailing once they 'age out' of junior programs. The following is one of the success stories.

Brooks Reed of Santa Cruz was featured in *Latitude 38* as El Toro Junior Season Champion in 2002, when he was 14, and a member of Santa Cruz and Richmond Yacht Clubs. He received RYC's John Kostecki Award for Junior Sailor of the Year in 2003. "Brooks is one of my favorite students," said John Amen, one



ALL PHOTOS SERGE & ROBIN TESTA

reed now?

of his sailing instructors at the time. Apparently both the dedicated-sailor and the good-student roles have stuck with Brooks over the past 12 years.

Since we last heard from him, he won Bronze in the Sears Cup sailing with Jesse Wedler and Matt Noble (now a reserve crewmember in the Volvo Ocean Race for Team Alvimedica) and Brooks also won the Orange Bowl in the 29er in 2003. As a member of the MIT sailing team, he won the Schell Trophy (a Northeast regional

continued in middle column of next sightings page

going big — continued

the idea of building a 49-ft aluminum Cybercat designed by Tim Mumby, and by now they are roughly 3/4 of the way through the massive do-it-yourself project. They bought plans from Mumby, rented a spot in a Queensland boatyard, bought five tons of aluminum, and went to work.

Big, fast, sturdy and safe, the sleek cat would appear to be the polar opposite of *Acrohc Australis* (the 12-footer). "One of the things we liked about the Mumby design is the beautiful curve in the hull," explains Robin. "Using recycled materials, Serge built a bender. Many, many bends and many, many welds later, hull #1 was done and turned right-side-up using a homemade crane and gantry, also built from recycled materials. Then, he did everything again for hull #2. Once

continued on outside column of next sightings page



SIGHTINGS

going big — continued

the second hull was complete and turned right-side-up, it was time to build the bridge deck and the forward beam joining the two hulls."

Next, Serge welded in bulkheads, frames and stringers, installed two new Yanmar 39hp engines with saildrives, and added deck beams and outside plating. Fuel tanks have been built in, windows are framed in, and the hatches are built. "The pile of aluminum plates has shrunk to almost nothing," says Robin. Among this design's somewhat unusual features is a small forward cockpit in addition to a stern cockpit. That one is "roomy and sheltered, and the salon and galley are on the same level."

The couple is visiting California this month, but they'll soon be back in Queensland to finish the exhaustive project. What's the game plan once she's finished? "We'll probably sail her for a while — not sure where yet — and then sell her," says Robin. Their bucket list is apparently long and varied, and not all of it involves sailing. "We are both now in our sixth decade, so we have to get cracking!" We wish them the best of luck with all that.

By the way, Serge's book, *500 Days, Around the World in a Twelve Foot Yacht*, is still available in both print and electronic editions via Paradise Cay Publications or Amazon.

— andy

brooks reed

fall championship) in 2006. During his career at MIT, he's also been skipper of the All New England sailing team, as



Brooks Reed

well as an Academic All American. Brooks says the East Coast collegiate sailing programs are rigorous, and he continues to improve due to the competition and the camaraderie there.

He added the F18 catamaran to his lengthy sailing résumé in 2011, winning the 2013 Canadian Nationals. He ranked fourth in the F18 in 2012 and '13.

He spent the past summer sailing a foiling International Moth out of the MIT sailing pavilion on the Charles River in Cambridge, MA. The MIT sailing program

MIT SAILING



FIN BEVEN

— continued

tries to promote technology in their sailing program, and Brooks believes that the Moth will help attract prospective students.

"Brooks is working his tail off finishing his thesis," wrote his proud dad, Steve, in November. "He's trying to steal a few more Moth days before the ice takes over the waterfront (they have *serious* winters there)."

Brooks is receiving his PhD in Ocean Engineering at MIT. He'll 'defend' his doctoral thesis this month. The title? "Controller Design for Underwater Vehicle Systems with Communication Constraints," which has to do with finding ways for small, autonomous submarines to communicate and navigate. Sounds like something we'll need Lee Helm to explain.

— chris



The annual 'From Here to Eternity' kissing contest is always the highlight of the Baja Ha-Ha beach party in Cabo San Lucas. We weren't able to identify these participants, but we sure admire their spirit. We'll give them an A for effort.

30 years of ultimate sailing

If a photo is worth a thousand words, over the last 30+ years Santa Barbara sailing photographer Sharon Green has generated the equivalent of half a billion words. Last year she and her assistants managed to whittle the number down to "a lot" for inclusion in her just-released 224-page coffee table book titled *30 Years of Ultimate Sailing*. Among the boats featured are those of West Coast sailing legends Jim Kilroy, Roy Disney and Philippe Kahn, as well as the magnificent cats of the 34th America's Cup.

An additional attractive feature of the book is a series of brief recollections of personal 'Ultimate Sailing Moments' by the likes of Northern Californians Paul Cayard, Stan Honey, John Bertrand and Philippe Kahn, and Southern Californians Annie Gardner, John Kilroy and Jimmy Spithill. Our favorite, however, is by the always-humble Buddy Melges, who came out of Zenda, Wisconsin, to take on 105 other skippers in the epic 1976 Star Worlds on San Francisco Bay. With the 20 knots of wind and big chop on the Bay, Buddy and crew reached the first mark of the first race an astonishing two full minutes ahead of sailing immortals Dennis Conner, Lowell North, Tom Blackaller and Bill Buchan. Melges went on to win the Star Worlds, and, back in those days, it was huge.

When you photograph yacht racing as much as Green has, sometimes you just happen to be in the right place at the exact right time. The 1991 Maxi Worlds in Newport, Rhode Island, for example, when Green caught the Italian-owned maxi *Longobarda* at the moment of dismasting, a split second when the 'Flying' Doctor Victorio of Italy, who had been standing back by a runner, was catapulted some five feet into the air. That photo is on pages 70-71. The good doctor didn't get hurt — or even wet — for as can be seen in Green's inset photo, he was snapped back aboard the boat, face first.

Green's photos are sort of like children to her in that she doesn't have a favorite. "But I have to admit that I love the photos of the colorful spinnakers and blooper of the boats in the 1970s and 1980s St. Francis

Big Boat Series. When I present my program at boat shows around the world, I contrast those colorful days with, for example, the 2014 Big Boat Series, where everybody has a boring white spinnaker and there isn't, of course, a blooper in sight."

Are there any audience favorites? "They like the photos when there is lots of wind and boats are getting hit by high-impact waves. There is a photo of *America One* during the America's Cup in New Zealand that is very popular. It's on page 216. Another favorite is Roy Disney's 94-ft *Pyewacket* coming down the Molokai Channel, which is on pages 168-169."

What's Green's favorite race to photograph? "The Transpac! But it

continued on outside column of next sightings page



Sharon Green surrounded by her art.

ULTIMATE SAILING



We don't know the boat name, but we'd bet everyone who was aboard during this dismasting remembers it vividly.

SHARON GREEN / ULTIMATE SAILING

ultimate sailing — continued

can be very frustrating for me as the best boats often finish at night. One year Stan Honey was navigating the 100-ft *Alfa Romeo*, and before the start I asked him when they were going to finish. For a 2,200-mile race, he gave me a very specific finish time, like 1:59 a.m. A few days later, I get a call from Jimmy Pugh, who told me they were going to finish at 4 in the afternoon — daylight! So I rushed down to the Santa Barbara Airport and rallied the troops in Honolulu. I also emailed Honey to confirm the finish time. I got really bummed out, because Stan told me their ETA was still 1:59 a.m. Jimmy had apparently gotten confused between local and Greenwich time. So we had to stand down. But you know when *Alfa Romeo* finished? At 1:59:30 a.m. How could Stan have only been 30 seconds off on such a long race?"

One might not think that being a sailing photographer is a particularly dangerous occupation, but Sharon can tell you differently. Once she was aboard a single-engine photo boat at the weather mark of a big Farr 40 regatta on a windy day off Miami. The engine died just as the fleet of intense racers arrived. It was even worse one year when she was following *Insatiable* on the reaching leg during a windy Big Boat Series. "The wake flipped the Boston Whaler I was on, pitching me and all my camera equipment into the water. Fortunately, most of my exposed film was in Ziploc bags."

The most dangerous, however, are the helicopters. "I've been in a lot of helicopters when some alarm went off or there was a funny noise. The scariest was one day when an alarm went off when we were way offshore of San Diego. We had to make an emergency landing. But it's the helicopter pilots of Miami who really scare me, as most are relatively inexperienced, and they always seem about to fly into the second spreader of some boat."

Not that great photographs can't be taken with almost any decent camera, but Sharon Green uses Canon equipment.

— richard

a book for every sailor's stocking

Call us old fashioned, but we like books. We don't mean the latest Kindle download — we mean real books. You know, the musty things stacked on shelves in your grandparents' house? While electronic reading is quick, and we do our fair share of it, there's nothing like kicking back with a good book. It's more personal, we feel more engaged with the author, we actually like holding it and turning the pages, and reading a book just seems more — 'legitimate', for lack of a better word — than reading it on some screen. Like jumping into the water with a mask and fins rather than watching a GoPro video of snorkeling on YouTube.

And hey, in a real book the batteries never go dead! Books make excellent gifts, even for techie-sick teenagers who can't engage with anything but smartphones — and even if they don't know it yet. Some of the most meaningful gifts we've ever received (or given) were books — even if *we* didn't know it at the time. So while you can download pretty much any book instantly and more cheaply than buying one, if you're looking for something special for the sailor in your life this holiday season, we suggest the real thing. And please write something nice in the front of it with the date and your name.

The crop of books we selected for review this year is not as eclectic as in the past. With a few exceptions, they are primarily memoirs — personal voyages of discovery, each unique, each uplifting, and each a celebration of the human spirit. What better time of the year to bestow such subject matter than now? Good Christmas and Merry Reading!

The Little Blue Book of Sailing Wisdom (Edited by Stephen Brennan, \$16.95) — Besides being a sport and pastime enjoyed around

continued on outside column of next sightings page

filmmaker focuses on

Filmmaker Oleg Harenar says he's always been fascinated by Sausalito's colorful waterfront community. So much so, in fact, that he considered making a film about all aspects of waterfront life there. But he soon realized that such a subject would be too overwhelming, so instead he decided to film a series of video documentaries called *Life on the Water* that spotlight worthy waterfront characters.

The first, which was shown last month at the Corinthian YC, profiles 89-year-old Ron MacAnnan, longtime owner of the 82-ft M-boat *Pursuit*, which he's maintained



ALL PHOTOS SHARON GREEN / ULTIMATE SAILING

If you think sail handling is complicated now, you should have been sailing in the era of bloopers. Sharon Green's new book showcases key moments during 30 years of sailing history.

'life on the water'

almost singlehandedly for decades.

Sometimes irascible, yet much-loved and respectful, MacAnnan explains his waste-not-want-not philosophy, shares sailing tales, and gives insights into the colossal effort he's made to keep his nautical thoroughbred in great shape. And the sailing shots are thrilling.

Next up are profiles of Hank Eason of *Yucca*, and the late Howard Sommer, former owner and restorer of the prized Bay Area schooner *Wander Bird*. Check out the series at www.lifeonthewater.us.

— andy

sailing books — continued

the world, sailing is one of literature's most popular metaphors for life. It will take about five minutes flipping through this nifty little book to see why. Stephen Brennan has brought together hundreds of sailing-related 'oms' — axioms, idioms and wisdoms — from such far-flung sources as Shakespeare, Hemingway, Churchill, Conrad and Homer. The quotes, grouped into chapters such as 'Seamen and Women,' 'Storm and Calm', 'Weather Eye' and 'The Philosophic Sailor' are inspirational, sobering, perceptive, witty and inspiring. Of particular note are all the weather-related sayings of old. We've all heard 'Red sky at morning...' before. But Brennan has dug up nearly 40 more, all simple rhymes to foretell what's to come: "Rainbow to windward, foul falls the day. Rainbow to leeward, rain runs away." Our biggest chuckle was from Winston Churchill, speaking to the

continued on outside column of next sightings page



SIGHTINGS

sailing books — continued

Board of Admiralty in 1939: "Traditions of the Royal Navy? I'll give you traditions of the Royal Navy — rum, buggery and the lash."

Lee Shore Blues (Peter Heiberg, \$19.99) — One of the perks of sailing journalism is getting to meet new and interesting people. One of these was Peter Heiberg, who regular readers may remember competed in both the 2012 and 2014 Singlehanded TransPac races from San Francisco to Kauai. One of the lowlights of sailing journalism is that the time constraints of the job don't allow us to get to know new people all that well. So we were at once surprised, delighted and a bit awed by Peter's book, *Lee Shore Blues*, when it arrived on our doorstep. In a nutshell, we felt as if this guy we'd shared a few laughs with turned out to be the lead singer in some legendary rock band. Heiberg writes - and writes well — of a rollicking lifetime at sea; of boats, women and good times; and of taking his lumps as he (seemingly often) learned things the hard way. His engaging style is reminiscent of several popular cruising writers of the past 25 years

continued on outside column of next sightings page

hawaii race planning

A lot of planning goes into preparing an entry for a race to Hawaii. Pacific Cup Yacht Club wants everyone to have plenty of time to get ready for the next Pacific Cup, so they've already announced the date of the first starts: Monday, July 11, 2016. Starts are generally spread out over a few days, with the fastest divisions departing San Francisco Bay last.

Also in the spirit of preparedness, PCYC has announced the dates of seminars in 2015 that will help educate sailors anticipating the ocean crossing. Encinal YC in Alameda will host a Safety at Sea Seminar on Sunday, May 17, and Richmond YC will host Pacific Offshore Academy Seminars on June 13 and October



Happy Holidays
from Latitude 38

has already begun

17, both Saturdays.

Gary Troxel steps into the role of PCYC Commodore for this cycle, Buzz Blackett is Vice Commodore, and Melinda Erkelens is Rear Commodore. All are veterans of multiple Pac Cups.

Go to www.pacificcup.org/2016 to sign up for Pac Cup news.

Entries are already open for the 2015 Transpacific Yacht Race from Los Angeles to Honolulu, with starts on July 13-18. See www.transpacrace.com.

The Singlehanded Sailing Society is considering June 18 or 25, 2016, for the start of the next Singlehanded TransPac from Tiburon to Hanalei Bay, Kauai.

— chris

sailing books — continued

— just with an 'R' rating.

Victura — The Kennedys, a Sailboat and the Sea (James W. Graham, \$29.95) - Of the zillion or so books written about the Kennedy clan, *Victura* is our new favorite. (Disclaimer: we haven't read all zillion.) But it's hard not to be biased when its main focus is the role sailing played in their lives. John F. Kennedy and his siblings grew up sailing on Nantucket Sound. In the '30s, Jack and older brother Joe Jr. won a number of local and collegiate championships sailing Star Boats.

But most of their sailing, racing and character-building was done aboard a 25-ft Wianno Senior gaff sloop that Jack named *Victura* — Latin for 'about to conquer'. The boat (Seniors are an indigenous design for Nantucket, sort of like Bird Boats are for the Bay) was ordered new by the family in 1932, when Jack was just 15. He returned to sail her many times over the years, even as president. A favorite story in this gem of a book is a blowy race when Jack and Joe were on different boats. On *Victura*, Jack and crew had to replace a broken



So many cool books. Buy them for gifts or read them yourself.

tiller just before the start, and found themselves dead last on the first weather leg. By the final leg, they had worked their way up to second, hard on Joe's heels. A gust hit the frontrunners and when the boats got back on their feet, Jack looked up to see his gaff had snapped in half. Most sailors might have seen it as misfortune and retired. Jack saw it as an 'instant reef' and pressed on, overtaking and passing his overcanvassed brother's boat at the finish by half a boatlength.

Mermaid Sails the Bay (Greg Trybull, \$19) — What do you get when you cross *Stand By Me* — without the dead body — and *Summer of '42* — without the sex? Both those works came to mind as we adventured with the main characters in this novel: three brothers growing up on the Belvedere Lagoon in 1908. Their father is captain of the scow schooner *Alma*, and the boys are co-captains of a Whitehall skiff named *Mermaid*. During the course of one summer, they cross tacks with all manner of sail and power vessels — including Roosevelt's Great White Fleet — explore islands and other landbound attractions, and interact with an ever-changing cast of real and imagined waterfront characters. Author Trybull grew up sailing the Bay and Delta aboard his father's Seafarer 29, and his local knowledge shows. And he has obviously done painstaking due diligence to recreate the Bay and environs as they were back then, with references to, among other things, the drawbridge at Belvedere, Lyford's Tower, and even Drake's Plaque. A fun read, particularly for younger readers.

Winging It — *Oracle Team USA's Incredible Comeback to Win the America's Cup* (Diane Swintal, R. Steven Tsuchya and Robert Kamins, \$24) — The Red Sox at the '04 World Series, 1980's Miracle on Ice at the Olympics, 1969's Amazin' Mets — take your pick of sports' greatest come-from-behind stories. Then add Oracle Team USA's still unbelievable eight-straight-race rebound from the brink of defeat to win the 2013 America's Cup over Emirates Team New Zealand. This book delves into and answers many of the questions on everyone's mind about how they did it, from the development of a completely new, next-generation sailing platform (according to one designer, the main function of an AC72 hull was "board delivery device") to building — and rebuilding — them, to the steep learning curve of sailing them. And the biggie — how Oracle, obviously outclassed in the early going, managed to become the superior boat in the end.

— jr

Look for more reviews next month.



LYNN RINGSEIS

BAJA HA-HA XXI RECAP —

With a 20-year legacy of San Diego-to-Cabo rallies to draw from, you might think that every aspect of the 21st annual Baja Ha-Ha would be totally predictable. Not so. Although considered a great success by the vast majority of its 525 participants, this year's fleet faced a unique set of challenges —

like-minded adventurers.

It's mildly ironic that this year's unscripted schedule changes were actually more similar to 'typical cruising' than showing up at pre-specified locations on a strict timetable would be. After all, as any experienced voyager will tell you, the cruising life, while often glorious and life-affirming, is all about coping with a wide variety of challenges — and it's rare to arrive anywhere on a precise schedule. In that regard, you might say the 2014 Ha-Ha was more like *real* cruising than any before.

One thing that has been consistent since the first Ha-Ha in 1994 is that fleets have always been made up of a wide variety of sailing craft — from immaculately kept yachts to no-frills plastic classics — and have been crewed by sailors of vastly different backgrounds. As you may have read in our three installments of fleet profiles (September-November issues), the range of professions within the fleet included firefighters, airline pilots, surgeons, park rangers, engineers, teachers, self-described boat bums and even a submarine operator. But they all shared the same dreams of cruising the sunny latitudes of Mexico.

We were pleasantly surprised that 171 boats signed up this year — up 5% from 2013 and 15% from 2012 — especially because during the months leading up to the October 27 start there was lots of confusion about new on-

line immigration and yacht import (TIP) procedures. As we've often pointed out, though, despite there still being some bugs to work out of two Mexican government websites, these new resources have been developed — and will continue to improve

— in order to make it *easier*, not *harder*, for North American mariners to visit Mexican waters. In fact, our partners at Mexico Tourism and representatives from several Ha-Ha sponsors have been working tirelessly to streamline these procedures. But even now, despite the understandable angst of some first-timers, clearing in and securing visas was largely "no problema" when the fleet arrived at the Cape.



The youngest — and cutest — pirate was two-year-old Grace Walter of 'Reprive'.

As you might imagine, prior to the start of this 750-mile offshore cruise there's always an undercurrent of anxiety among the neophyte cruisers in the fleet. One of the best ways we know to lighten their mood is to encourage them to dress up in goofy costumes and join the revelry of the Ha-Ha's annual Costume Kickoff Party — staged the afternoon before the start of Leg One. Think about it: How stressed out can you possibly be when you're dressed up like a jellyfish, a swash-buckling pirate, or a "lab experiment gone wrong?" (See photo left.) Works every time to lighten the mood and infuse a spirit of frivolity into the entire fleet.

As in years past the *fiesta* was generously cohosted by West Marine on the grounds of their Shelter Island 'flagship' mega-store. This year, in addition to the usual assortment of swaggering buccaneers and flirtatious wenches, Austin Powers and his entourage made a special appearance. There was also a bevy of jailbirds, a pride of snarling cheetahs, a band of scraggly haired hippies, and a tribe of Maori warriors, as well as King Neptune and his mermaid lover.

Upon entering the venue, each captain was given a swag bag filled with hats, T-shirts, and other lo-goed souvenirs. Meanwhile, local caterers served crews a Mexican 'tune-up' lunch, washed down with cool libations from the bar.

After the costume contest — flamboyantly emceed by West Marine's own Captain Ron — the excitement wound down around 4 p.m. in order to give every crew plenty of time to make last-minute purchases and preparations, and to allow everyone a good



Over the years we've seen costumes based on all sorts of themes, but this group of "lab experiments gone wrong" was a first.

not the least of which was what to do about a weak but foreboding late-season hurricane named Vance.

As you'll read below, in the interest of safety the Ha-Ha's time-tested itinerary had to be altered for the first time ever. But doing so didn't keep the event from achieving its primary goals: to introduce many new cruisers to the cruising lifestyle, while giving veteran Mexico travelers a new offshore adventure — and acquainting them with a new set of

Dignitaries and local media pros recorded the fleet's departure from the deck of the 'Dolphin'. This year, even CNN caught the action.



ALL PHOTOS LATITUDE / ANDY EXCEPT AS NOTED

RALPH PACE



THE ONE-LEGGED HA-HA



night's sleep prior to the next morning's 11 a.m. start.

Ever since Ha-Ha *numero uno*, the rally has always started from San Diego, but it wasn't until about five years ago that members of the San Diego Port Tenants Association encouraged us to put on a little show as we made our exit for Mexican waters. So we cooked up the idea to parade the fleet through

How stressed out can you possibly be when you're dressed up like a jellyfish?

San Diego Harbor on its way out to the starting line, just outside the bay. By now, it's become a tradition for local TV, radio and print journalists to get out on the water aboard the sportfishing vessel *Dolphin* to record the fun. This year there was even a crew from CNN who, we're told, aired the spectacle nationally. Also aboard to show their support were Alejandro Santander of Mexico Tourism and Consul General of Mexico



The costume party put everyone in a lighthearted mood. But we're pretty sure West Marine's Captain Ron had the most fun of all.

Remedios Gomez. Referencing Cabo's recent battering by Hurricane Odile, Gomez said, "The Baja Ha-Ha sends an important message that Cabo is ready and able to welcome all the cruisers and other tourists." At precisely 10 a.m. Coast Guard Captain Jonathan Spaner shouldered the San Diego YC's official America's Cup shotgun and hailed the Ha-Ha'ers with a celebratory blast.

As the fleet motorsailed out the channel to the harbor entrance, the pre-start roll call revealed that 131 were rarin' to go, while several others — as is typical — would be late starters because they needed to make last-minute repairs or purchases. Several others would start from Ensenada, 60 miles south of the border.

Reminiscent of the old saying, "all dressed up and nowhere to go," fleet members were totally psyched for the

Somehow the wind gods didn't get the message that we needed some breeze, but the fleet was thrilled to be heading south nonetheless.



360-mile leg to Bahia Tortugas. Their boats were as ready as they'd ever be, the sun was shining through patchy cloud cover. . . There was only one thing missing: wind. Fall mornings are often windless in San Diego, but during past Ha-Has more often than not the breeze has filled in right around 11 a.m. No such luck this year, though; there was barely a zephyr.

However, one of the great things about a rally like the Ha-Ha, as opposed to a serious race, is that entrants can run their engines whenever they want. So the Rally Committee's long-established solution to light air is to proclaim a 'rolling start', whereby every boat can motor down the rhumbline at six knots without penalty until the breeze fills in and the leg is officially started.

Throughout that first day and night, winds remained uncharacteristically light, fluky and frustrating. During the afternoon and early evening, though, many boats with light-air spinners got in some decent sailing, but the usual northwesterly never really filled in along the rhumbline, although sizeable swells hinted that there was



BAJA HA-HA XXI RECAP —

probably more wind to be found farther offshore. If there was a silver lining, it was that the light air gave nervous first-timers a very mellow intro to offshore cruising — plus, there was minimal gear breakage and everyone was getting plenty of nap time. With most boats motorsailing, the fleet was more tightly packed than ever, so many crews had the shared experience of watching several pods of whales cavorting near the uninhabited Coronado Islands and elsewhere farther down the track.

The breeze improved on day two, but it still wasn't consistent enough to call off the rolling start, so many boats continued to motorsail. We'd never before had such bad luck with finding consistent wind on Leg One, but everyone

simply took it in stride. On the Wednesday morning net, lots of boats proudly reported catching big dorado (mahi-

He reported catching a dorado longer than his 10-year-old son.

mahi) and tuna — a standout was a report from Michael Bradford of the Portland-based Hallberg Rassy 42 *Pelagic*

ic who said he caught a dorado longer than his 10-year-old son Porter is tall. Aboard the Oregon-based Hans Christian 38 *Penelope*, Peter Gierga reported: "We hooked up 14 times and landed 7 dorado in an hour and a half." Buck Reynolds of the trawler *Sea-Esta* trumped that tale with his own fish story: "We had to stop, there were so many fish out there. We had 100 dorado behind the boat; we had to speed up to get away from them."

A number of boats — including the Sausalito-based Hughes 48 *Iolani*, the

Clockwise from upper left: Dolphins ride the bow wave; kids tend to make friends instantly; field of dreams; volleyball vitality; grilling game fish for the masses; trick-or-treating boat to boat; chillin' in the shade; ideal beginner waves; the conga line snakes to the potluck; tug-o-warriors.

ALL PHOTOS LATITUDE / ANDY EXCEPT AS NOTED



THE ONE-LEGGED HA-HA

Utah-based Catalina 42 *Seaduction*, and Vancouver, BC boats *Touchstone*, a Valiant 40, and *Papillon*, a Pacific Seacraft 37 — reported finding as much as 15 knots of wind, at least periodically, by venturing farther offshore. The crew of *Joyride*, a J/109 from San Jose, were thrilled to have sailed all night and said they actually had to put a reef in when the breeze piped up above 14 knots. Unfortunately, several boats reported engine trouble, and the Seattle-based Cheoy Lee 44 *Cavale* gave an enthusiastic thank you to *Comet*, a Morgan 36 out of Marina del Rey, for towing them into the anchorage.

In addition to lots of whale sightings,



FIN BEVEN

'Reina del Mar' Patsy Verhoeven of 'Talion' (silver tiara) hoists a glass with princesses from her all-girl crew.

reports of huge schools of dolphins were often heard over the VHF — having them play in your bow wake is always a special treat. Both air and sea temperatures were warmer than usual, making even middle-of-the-night watches pleasurable — especially under a moonless

canopy of a gazillion stars.

Jack and Sylvia McDermott of the San Francisco-based Beneteau 50 *Belle* pulled into the vast, well-protected anchorage of Bahia Tortugas (Turtle Bay) early enough Wednesday night to rush up to Vera Cruz Restaurant and catch the final game of the World Series on the flat screen in the 'disco' bar there. Meanwhile, offshore, other rabid Giants fans did whatever they could to follow the action. Some pulled in the national broadcast via satellite radio, while others were able to pick up San Francisco's mighty KNBR on their AM radios (despite being 750 miles from the station's transmitter). Still others soaked in the excitement third-hand, as David Johnson of the San Francisco-based Dehler



BAJA HA-HA XXI RECAP —



FIN BEVEN

It's not hard to imagine what was on Jim Doty's mind when he had this custom chute designed for his Crealock 34 'Osprey'.

41DS *Flying Squirrel* relayed the play-by-play action via VHF.

Among other news on the Thursday morning net, the Rally Committee noted that the meteorological experts at Commander's Weather, a longtime rally sponsor, were keeping their eyes on a developing weather system south of Acapulco (1,000 miles from the fleet's location), which was expected to continue north toward Cabo, then arc toward Mazatlan on the following Monday or Tuesday, two or three days before the fleet's scheduled arrival. At that point, the system had not garnered enough strength to become a named storm, but it had the potential to do so.

With four 'kids' on board from 6-years-old to 20, the San Francisco-based Lagoon 470 'Family Circus' was a very happy boat.



ALL PHOTOS LATITUDE / ANDY EXCEPT AS NOTED

The simple wooden houses and dusty, unpaved streets of Bahia Tortugas often get a "This is it?" reaction from first-time visitors. But the exceedingly friendly reception visitors receive from the townspeople soon reveals why this bay has long been a favorite stopover for both southbound and northbound sailors.

Unlike Cabo San Lucas and other tourism Meccas, this unpretentious village, far from the nearest real city, is what many seasoned travelers would call "the real Mexico," a place where most men embrace the hard life of a fishermen, as did their fathers and grandfathers before them. Life here is simple with few fancy frills, yet the residents seem universally cheerful and content.

One of the locals' obvious passions is baseball, evidenced by the fact that they have four traveling teams — from six-year-olds to adults — whose brightly colored uniforms, we'd bet, are among their most cherished possessions. Perhaps in recognition of this local passion, the government recently graded the town's formerly dirt-and-gravel ballfield, and completely covered it with AstroTurf. In a town that literally does not have a single blade of natural grass, the new field is a marvel — truly a field of dreams.

Ha-Ha fleet members borrowed it for a couple of hours on Thursday, October 30, in order to stage the rally's annual anything-goes baseball game, in which every batter gets as many pitches as it takes for him or her to get a hit. Despite there being roughly 20 fielders on the ballfield at any given time, a modest grounder often results in at least a double due to frequent overthrows and dropped balls. Batters from 4 years old to 77 took a turn at the plate. To the locals, of course, such antics are hilarious entertainment. Nevertheless a couple of dozen local kids joined in to show us how the game is supposed to be played.

That night many sailors congregated at the Vera Cruz, in the heart of town, at Maria's above the main beach, and at the Deposito, a funky beachfront shack whose seating area is decorated with the giant ribs and vertebrae of beached whales.

There's roughly eight miles of sandy beach ringing Bahia Tortugas, but most of it never sees

a human footprint. Every year, though, Ha-Ha'ers converge on a stretch of sand about a half mile east of town for a massive beach party.

There's no big agenda; the idea is simply to have fun and get acquaint-

In stark contrast to the weak and wimpy winds of Leg One, conditions on Leg Two were absolutely awesome.

ed with new friends. Due to Hurricane Odile, the beach was steeper and rockier than normal, but the volleyballers found a nice flat spot to play, while many kids practiced surfing the shore break on inflatable boards. A massive potluck was laid out, and to keep things lively the chow line was transformed into an enormous snaking conga line, where hungry sailors swayed and shuffled to the DJ's dance mix.

The RC set up a beach barbecue where some of the more successful fishermen grilled fresh-caught tuna, wahoo and dorado to share with the masses. As always, there was a male-versus-female tug-of-war, and as always the deck was stacked so the women were victorious. And the Poobah submitted to another annual ritual: being pummeled by (biodegradable) water balloons hurled by every kid in the fleet.

Because it was Halloween, that evening several dinghies full of kids in costumes trick-or-treated from boat to boat in order to build up their candy stashes for the trip south.

The master schedule called for the fleet to begin 240-mile Leg Two at 8 a.m. Saturday morning, November 1, and on that morning most fleet members were champing at the bit to get out sailing, as the prediction for the next few days was for 12-20 knots of wind from the northwest — plenty of breeze to move the heavy-displacement boats along nicely, and ideal for surfing the swells aboard the light-displacement boats.

But there was another factor to consider. When the rally's Grand Poobah



GRAHAM WILSON

THE ONE-LEGGED HA-HA

checked in with Commander's Weather prior to the morning net, he felt the full weight of his responsibilities as shepherd and guardian of the fleet. That pesky northbound weather system they'd been tracking had reached tropical storm status and was given the name Vance. Although computer models generally agreed that it would probably turn inland well south of Cabo, the weather gurus strongly urged the fleet to stay put for another day. The Rally Committee reluctantly agreed.

Given the ideal sailing conditions, the unplanned hiatus was frustrating, but no one really seemed to mind having another lay day. To pass the time, a group of stand-up paddleboarders and

calcs in celebrating the Day of the Dead with a grand costume party that night at the Vera Cruz.

Sunday morning imposed an even tougher decision on the Poobah and the Rally Committee. By this time, they'd consulted three different weather routers, and all urged the fleet to stay put. Vance was still tracking north, vacillating in and out of hurricane status, and had not yet begun its predicted

turn to the east. Never before had the Rally Committee had to delay the schedule by even a single day, let alone two. But given the fact that highly destructive Hurricane Odile had clobbered southern Baja only seven weeks earlier, we suspect all the routers were feeling overly cautious.

The situation was particularly frustrating because Vance was well over 500 miles away — like worrying about a storm in San

Diego when you're sitting in San Francisco. But if it did not turn and continued up the peninsula, the fleet might find itself in a more exposed position at Bahia Santa Maria, the normal second stop, or in nearby Mag Bay.

When several highly experienced Mexico cruisers insisted they were ea-

Retired air traffic controller Doug Schmer of the Hylas 44 'Velella' surveys the fleet at pristine Bahia Santa Maria.



When the fleet finally left Turtle Bay, there was plenty of breeze to spinnaker-reach right out of the anchorage — glorious sailing.

ger to head south, the Poobah decided to poll the fleet for every boat's input. Only 41 boats voted to move on, while the rest elected to sit tight for another day. The early departers — who dubbed themselves Bravehearts — understood that they were officially dropping out of the rally temporarily, but 10-time Ha-Ha vet Harry Hazzard of the Idylle 15.50 *Distant Drum* volunteered to conduct a daily roll call and report in to the RC a couple of times a day via SSB.

By Monday morning Vance had begun its predicted turn toward the mainland and sailing conditions were still excellent for the blast to BSM — in fact, the prediction was now for stronger NE winds of 15 to 25 knots. (*Distant Drum* had recorded a max of only 11-knot winds the day before). It was high time to hoist the sails and have some fun. Besides, the town had literally run out of Corona and Pacifico beer, and was down to its last reserves of canned Tecate. Seriously.

In stark contrast to the weak and wimpy winds of Leg One, conditions on Leg Two were absolutely awesome — especially for the bigger boats. With 20 knots or more on the beam, the entire fleet was soon flying down the course at hull speed or better, given the added push of 4- to 6-foot swells. Without a doubt, it was one of the fastest Leg Twos ever.

While the majority of the fleet was still at sea Tuesday morning, most of the Bravehearts had already made landfall. "We're anchored in the bay," radioed one of the leaders on the morning net. "There's flat water and it's just as beautiful as it could be." That was good news for some of the smaller boats. "It's a little bumpy out here for a Rang-



"Woo-hoo!" yelled the crew of the HC 50 'Fast Reorgg'. The wind was up and it was time to head south.

kayakers raced around the committee boat, *Profligate*, while others spent quality time getting to know the townspeople, hiking the nearby hills, swimming in the unusually warm (75°) bay, playing dominos at the beach bars, doing boat chores or catching up on their sleep. The culturally curious joined lo-



BAJA HA-HA XXI RECAP —



LYNN RINGSEIS



LATITUDE / ANDY



LYNN RINGSEIS



LYNN RINGSEIS

er 33," said Richard Crumley of Bodega Bay-based *Entropy II*, "but we're having a great trip." With sloppy swells due to the change in wind direction, reports on the net indicated that, apart from a few seasick souls, almost everyone seemed to be having fun — although some were getting beat up a bit. At one point *Latitude 38* bookkeeper Penny Clayton got launched out of her bunk onto a sailbag while sailing aboard *Iolani*. Meanwhile, sails and gear took a beating too: *Distant Drum's* main tore, the San Francisco-based Lagoon 470 *Family Circus* suffered a torn chute, and aboard the San Francisco-based Able Apogee 50 *Scoots*, a new carbon-fiber spinnaker pole snapped, sending one of its splintered ends right through the headsail.

But many other call-ins were totally upbeat: Jim Milski of the Colorado-based Schionning 1480 *Sea Level* exclaimed: "We hit 21.7 knots yesterday evening while racing against *Profligate*. This has been some of the best sailing ever!" That comment was particularly impressive considering that Jim and his wife Kent recently completed a

Clockwise from upper left: 'Beach Access' crew strikes a pose; "Fish on!"; bird's eye view of the party on the bluff; young rockers set the mood with some help from two sailors; shakin' it at Squid Roe; Canadian 'Dream Catcher's set off on Leg Two; crossing the finish at the Cabo Falso light; the 'Speakeasy' crew proudly displaying their homemade "We survived Vance" T-shirts.

circumnavigation via the Cape of Good Hope.

Throughout the day conditions held — 20-25 knots with gusts into the low 30s — giving the fleet a fast, if bumpy, ride to the Leg Two finish line, which was roughly 600 miles south of San Diego.

On Wednesday morning's net the crew of the Alameda-based Freedom 30 *Sea Otter* jubilantly described their ride as "a rip-roaring sail" despite suffering some sort of engine problem. "That's the way offshore sailing should be," said Ed Choromanski of the Vancouver-based DownEast 38 *Seadra*. "What a great sail!" Many crews reported hitting their top speeds ever: "We sailed wing-and-wing for 8 hours, surfing at up to 18 knots," reported the crew of the Oregon-based Golden Wave 42 *Quest*. "Fantastic sail," said Gary Himes of the Montana-based Jeanneau 52 *Scout*. "We saw a top speed of 14.9 knots!" And at one point John and Deb Rogers of the

San Diego-based Deerfoot 62 *Moonshadow* clocked 16.8 knots.

Among the minor carnage reported, the Newport Beach-based Lagoon 380 *Beach Access* nearly lost her dinghy, when a shackle broke loose on the davit assembly at 4 a.m. The most unusual news, though, was that crews of both the Oregon-based Whitby 42 *WindRover* and the Long Beach-based Catalina 42 *Wayward Wind* had witnessed what they believed to be a "green meteorite crashing into the sea" less than a mile away from them. That was a first.

With the protection of its 10-mile-long oval anchorage, its miles of unspoiled white-sand beaches, and its easily hikeable mountains that yield spectacular 360° views, Bahia Santa Maria is always the favorite stopover on the Ha-Ha's itinerary. So it was a real shame that due to being held up in Turtle Bay, most fleet members only had a

THE ONE-LEGGED HA-HA



LATITUDE / RICHARD



FIN BEVEN



LATITUDE / ANDY



FIN BEVEN

day here. But they made the most of it. Early Thursday morning, November 6, crews began heading ashore to stretch their legs while hiking the ridge lines or doing some beachcombing — there are always plenty of shells and sand dollars on these untouched beaches, as well as the skulls and skeletons of beached whales and dolphins.

The only inhabitants of the bay are itinerant fishermen who spend several months at a time in crude shacks that line the mangrove lagoon, before returning to their families in the remote village of Lopez Mateos, which lies 25 miles to the north on a natural estuary. For them, the arrival of the fleet each year is a bizarre curiosity.

Years ago, an entrepreneurial fisherman named Victor shocked the fleet by putting on a rock 'n' roll party on the bluff above the bay, complete with a band imported from La Paz, seafood dinners for 400 people, and plenty of ice-cold beer. Such improbable fiestas have been an annual Ha-Ha tradition ever since.

In addition to dancing to the band, dining on fresh grouper or shrimp, and

playing volleyball on the beach below the bluffs, crews got together to share war stories about the rowdy ride south in Leg Two. At this point, having safely traveled 600 miles offshore, many of the first-timers were beaming with newfound self-confidence.

Leg Three began Thursday morning at 7 a.m. — not long after sunrise — so the smaller boats wouldn't have to spend more than one night at sea, as

"That's the way offshore sailing should be. What a great sail!"

the distance is only 180 miles. In stark contrast to the rambunctious conditions of Leg Two, the final cruise to the Cape was a bit of a yawner. Winds were very light and seas were flat as a mill pond much of the time. But there was no longer any worry that the Cabo anchorage

might be rolly, as Vance had steamed by two days earlier and was quickly fading into a meteorological footnote.

Skies were bright and sunny, with water temperatures near 80° — ideal for catching big game fish. Especially for sunseekers from the Northwest, experiencing bikini weather offshore was a dream come true. And if there's one thing that holds true about sailing anywhere in the world these days, it's that weather is 'reliably unpredictable', and you simply have to deal with whatever you get. This year's Ha-Ha fleet gets high marks for keeping an upbeat attitude despite the disappointing winds of the first and last legs. Both were throw-outs in terms of scoring, by the way, making this the first and only one-legged Ha-Ha.

There's always considerable angst over how many boats will be offered slips at Cabo Marina, as we allot them based on the order in which boats signed up for the event. The marina employees always knock themselves out to shoehorn in as many boats as possible, but this year it was particularly tough,

BAJA HA-HA XXI

BROUGHT
TO YOU
BY THESE
OFFICIAL
SPONSORS

WWW.BAJA-HAHA.COM

West Marine
For your life on the water™

Prepare for the 21st Annual Baja Ha-Ha
at a West Marine store near you!

For more locations near you
or to shop online 24/7 visit www.westmarine.com

The Rally Committee
encourages you to patronize
the advertisers who make
this event possible – and
take advantage of their
Baja Ha-Ha Specials!
(Turn the page for more.)



**New Sails
and Sail Repair**

(619) 226-1133

www.UllmanSailsSD.com



**New Mexican
Liability Program**

* Lower Rates * Instant Coverage *
* Short Term Policies Available *

(800) 992-4443

www.marinersins.com

See Our Half-Page Ad In This Issue

Newport Beach, CA • San Diego, CA
San Francisco, CA • Seattle, WA
Sarasota, FL

BAJA HA-HA MELTING POT

If you're new to the event, let
us explain that the Ha-Ha is a
750-mile cruisers' rally from San
Diego to Cabo San Lucas, with
stops along the way at Turtle
Bay and Bahia Santa Maria.

Check out the Ha-Ha XXI entry
roster at www.baja-haha.com
and you'll see that boat types
and sizes in this year's fleet were
as varied as ever, and you can
bet that the crews who sail them
were as colorful as in years past.

In addition to many first-
timers, there are plenty of 'repeat
offenders' who wanted to replay
some of the fun and great sailing
that they experienced the last
time around. Some full-time
Mexico cruisers even sail all the
way back to San Diego each fall
just to re-do the rally.

On page 68 of this issue you'll
find a complete recap of this
year's rally. And you can find
mini-profiles of all crews online in
the archived Sept.-Nov. issues at:
www.latitude38.com.



Est. 1973

Almar Marinas

Everywhere you'd like to be
www.almar.com

Your
Yacht Club
South of the
Border



Home
of the
Banderas Bay
Regatta

Vallarta Yacht Club

<http://vallartayachtclub.org>
<http://banderasbayregatta.com>

Everything you need from a full service yacht club.

Summer
is safe at
Paradise



Enjoy
your stay
with us!

011-52-322-226-6728 • www.paradisevillage.com
marina@paradisevillagegroup.com

Yachtfinders/Windseakers

in the heart of
San Diego's boating community

Specialists in cruising sailboat brokerage for 34 years
info@yachtfinders.biz • www.yachtfinders.biz

(619) 224-2349 • (866) 341-6189 toll-free
Fax (619) 224-4692

RIGGING ONLY

Standing and running rigging, lifelines, furlers, winches,
headsail poles, main slider systems, windlasses,
travelers, wire terminals, blocks and more...
Since 1984 Expert advice for selection and installation.

www.riggingandhardware.com
(508) 992-0434 • sail@riggingonly.com



Award-winning Marine Communications Equipment

Handhelds • Mounted VHF • SSB • AIS

Visit one of our many West Coast dealers

www.icomamerica.com/marine

SCANMAR

INTERNATIONAL, INC.

Home of the Monitor Windvane

Your Source for Emergency Steering Solutions

- M-Rud for your Monitor
- Standalone SOS Rudder
- Auto-Helm Auxiliary Rudder
- Saye's Rig Windvane

510.215.2010 • 888.946.3826 • Richmond, CA
www.selfsteer.com • scanmar@selfsteer.com

SCHAEFER

LEGENDARY STRENGTH

Schaefer Marine is proud to be a sponsor of the Baja
Ha-Ha. With over 45 years of experience manufacturing
the world's best marine hardware, we can help you safely
enjoy your cruising experience.

www.schaefermarine.com



Manson Anchors have
grown from a family of
professional boat build-
ers, marine engineers, and
staunch world cruisers.
They've been designed,
developed, tested and proven in the most demanding
boating regions on earth.

developed, tested and proven in the most demanding
boating regions on earth.

www.manson-marine.co.nz

BAJA HA-HA XXI

Partner for Baja Ha-Ha 2014



Tourism Board

www.visitmexico.com

BROUGHT TO YOU BY THESE OFFICIAL SPONSORS

THE CRUISER'S CHANDLERY
2804 CAÑON STREET • SAN DIEGO
(619) 225-9411 / (800) 532-3831
FAX (619) 225-9414
www.downwindmarine.com

'everything a cruiser could ask for in New Zealand'



Whangarei
MARINE GROUP
NEW ZEALAND

www.whangareimarine.co.nz

MEET THE FLEET

Every year dozens of watchstanders find crew positions on the Baja Ha-Ha rally. If you weren't lucky enough to be one of them this time, don't give up because cruisers use our online Crew List year-round, offering rides to all sorts of exotic places. The list is constantly updated, and you can access it via www.latitude38.com. If you hope to cruise on your own boat someday, catching a ride with someone else first is a great way to prepare.

QUICKLINE
714 843-6964 • quickline.us

Let Marina El Cid Welcome You to Mexico
A Cruiser's Paradise!
www.elcid.com
marinaelcidmzatlan@elcid.com.mx
011-52 (669) 916-3468

- ★ Mexican Boat Liability Insurance ★
- ★ Accident & Illness Travel Health Protection w/Air Evacuation ★
- ★ Online Enrollment ★
- ★ Short Term Protection Available ★

(818) 788-5353
www.insurebaja.com
Info@InsureBaja.com

Health Protection Boat Insurance Full/Liability Only

NOVAMAR INSURANCE GROUP

Insuring yachts locally and globally since 1987

www.novamarinsurance.com

(800) 823-2798 USA • 01 (800) 627-4637 Mexico

WWW.HYDROVANE.COM

ECHO Tec Watermakers
watt&sea
STEERING THE DREAM

Best Marina in Banderas Bay



www.marinarivieranayarit.com
011-52-329-295-5526

IS THE PACIFIC PUDDLE JUMP FOR YOU?

For many cruisers, the next logical step after cruising Mexican waters for a season or more is to hang a right and head west into the Pacific.

We call that annual springtime migration the Pacific Puddle Jump, and we report on it heavily in the pages of *Latitude 38*. Making that 3,000-mile passage is one of the most thrilling accomplishments in the realm of sailing. Learn more about it at www.pacificpuddlejumps.com.

Todo Vela Mexico
BEST SELECTION IN MEXICO!
Harken - Marlow - Ronstan - NE Ropes
Marina Riviera Nayarit - Mercado del Mar #29
La Cruz de Huanacastle - Nayarit - Mexico
US 678-692-6784 or
MEX 322-278-0549
Info@TodoVelaMexico.com

BLUE LATITUDE PRESS
The best cruising information for the Sea of Cortez and Pacific Mainland Mexico
WWW.BLUELATITUDEPRESS.COM

Cruise ROwater
and power
Go Cruising, Not Camping, with High Output Water Makers, Alternators, Wind Gen and CoolBlue Refrigeration.

TECHNAUTICS
CoolBlue Marine Refrigeration

www.cruiseROwater.com

SAN DIEGO BAY'S HARBOR ISLAND WEST MARINA
Serving Southbound Cruisers in San Diego Bay for over 40 years
www.harborislandwestmarina.com
619.291.6440
CALL ABOUT OUR BAJA HA-HA CRUISER SPECIAL!

Weather, Email and Voice Solutions.
Satellite Phone Sales and Rentals.

OCENS
www.ocens.com
sales@ocens.com • (800) 746-1462



**Don't get stuck hand steering—
Get the reliable, powerful wheel pilot!**



- QUIET AND DEPENDABLE
- EASY OWNER INSTALLATION
- LOW POWER CONSUMPTION
- BUILT FOR IMMERSION

www.cptautopilot.com 831-687-0541



A Full Service Boat Yard in Puerto Vallarta
88 ton Travelift • Parts • Service • Repairs

011-52 (322) 221-1800 www.opequimar.com
info@opequimar.com



Exceptional location in the heart of Puerto Vallarta
to welcome Baja Ha-Ha cruisers

Full services • Travelift

011-52-322-221-0275 • www.marina-vallarta.com.mx



Custom Screen Printing & Embroidery for Sailors by Sailors

Yacht club and crew gear, wicking shirts, hats and more.

(888) 724-5286 • www.pirateslair.com



Marina Puerto de la Navidad is considered to be among the 10 best marinas in Latin America. Guests can enjoy all the services & facilities of the spectacular Wyndham Grand Isla Navidad Resort.

- 24-hr security • Electricity
- Pump out • Telephone • Laundry
- Cable TV • Wireless Internet
- 200-yacht capacity

hARBORMASTER@ISLARESORT.COM.MX

011 52 314 337-9014 • www.islanavidad.com.mx



"Always At Your Side"

+1-914-381-2066

For a free quote, visit www.pantaenius.com

IMPORTANT DATES

Although you missed your chance to join Baja Ha-Ha #21, there's always next year. The 2015 event will follow a similar timeline. Dates TBA soon.

Oct. 18 — Ha-Ha Welcome to San Diego Party, Downwind Marine, 12-4 p.m. Ha-Ha entrants only.

Oct. 25 — Pacific Puddle Jump seminar, West Marine, San Diego, 5 p.m.

Oct. 26, 11 a.m. — Skipper's meeting, West Marine, San Diego. Skippers only please.

Oct. 26, 1 p.m. — Ha-Ha Halloween Costume Party and Barbecue, West Marine, San Diego.

Oct. 27, 10 a.m. — San Diego Harbor Ha-Ha Parade.

Oct. 27, 11 a.m. — Start of Leg 1

Nov. 1, 8 a.m. — Start of Leg 2

Nov. 5, 7 a.m. — Start of Leg 3

Nov. 7 — Cabo Beach Party

Nov. 8 — Awards presentation hosted by the Cabo Marina.

Nov. 20, 4-7 p.m. — La Paz Beach Party. Mexican folk dancing, live music and more.

Baja Ha-Ha, LLC
c/o 15 Locust Ave., Mill Valley, CA 94941
WWW.BAJA-HAHA.COM

PLEASE NOTE:

Correspondence relating to the event can be emailed to andy@baja-haha.com.

Please don't call *Latitude 38* with questions. The Ha-Ha is a separate operation.



The place to be in La Paz,
conveniently located near downtown.

marinadelapaz@prodigy.net.mx
011-52 (612) 122-1646
www.marinadelapaz.com

La Paz Tourism Board
welcomes you to La Paz



Enjoy our Baja Ha-Ha
Beach Fiesta
November 20

011-52 (612) 122-4624
www.golapaz.com



SAN DIEGO'S RIGGING CENTER
Proudly serving for over 25 years

Design consulting • Commissioning • Refits
Custom line and hardware

WE SHIP RIGGING WORLDWIDE (619)
WWW.PACIFICOFFSHORERIGGING.COM 226-1252



**Cruise over and spend a night
at our beautiful Marina**
Slip reservations, call 805.984.7780

Located halfway between Malibu and Santa Barbara
BAJA HA-HA SPONSOR LAT 34° 10'20" N • LONG 119° 13'46" W

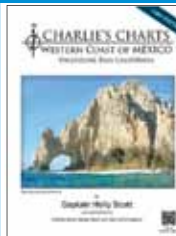

**NEW! Western Mexico
13th Edition with Expanded
Sea of Cortez Coverage**
www.charliescharts.com

Charlie's Charts

Cruising Guides • Gerry's Charts • Ships Store



Imagine You Were
Designing the Perfect Marina

MARINA CORTEZ

An idyllic La Paz location

011-52-612-123-4101
WWW.MARINACORTEZ.COM

SEASON CHAMPIONS, PART II —

Last month we profiled a collection of one-design and developmental class champions. This month, we turn our attention to the acronyms of the YRA (Yacht Racing Association of San Francisco), including the WBRA (Wooden Boat Racing Association), OYRA (Offshore Yacht Racing Association), and the YRA Spring and Summer Series.

We'll start off with the WBRA division of the YRA, which sailed 14 races with one throwout.

Bear Boat — *Smokey* Stephen Robertson, StFYC

Steve Robertson has been racing Bears on San Francisco Bay on and off since 1966, and this is not the first time he's graced these pages.

Indeed, he's won the Bear championship many times before, most recently in 2012. Of this season he said, "We just had fun out racing." The longtime crew on *Smokey* are Robertson's ex-wife Josselyn Robertson, Henry Englehardt, and Jeff Harriman.



Steve Robertson

1) *Smokey*, 20 points; 2) *Magic*, Tim Maloney, MMBA, 27; 3) *Huck Finn*, Margie Siegal, MMBA, 39. (4 boats)

Bird Boat — *Oriole* Jock MacLean/Hugh Harris, SFYC

The *Oriole* crew, skipper Jock MacLean, co-owner Hugh Harris, Jock's son Lachlan MacLean, and Shane Holt, have been racing the yellow Bird for two years.

Oriole was built in 1928 and launched in 1929, and has been sailed out of San Francisco YC for most of that 85 years. "My father owned her when I was in high school," said Jock, "and we sailed her to three championships in the 1970s."

In 2012, he and Harris found her in a boat yard, ready to be cut up for her lead and put in a dumpster. She spent six months in a shed at KKMI and was readied for the 2013 racing season, with new Pineapple sails and a major makeover. "She was fast until, during a leeward mark rounding, our championship hopes were dashed by another boat's sailing through her hull," said MacLean about the boat's 2013 campaign. "Back we went to the yard for repairs. This year we sailed clean and have some silver to



Shane Holt, Hugh Harris, Jock MacLean, Lachlan MacLean

show for it. *Oriole* has a new lease on life and now rests back at SFYC where she belongs."

Jock listed the season highlights: "Sailing with great guys and my son, getting the boat looking and sailing great, and winning the WBRA season, Class Perpetual, and the Fall Classic." Lowlights were: "Having a case of the slows in the middle of the year, and putting *Oriole* on the new sand bar off Crissy Field."

Getting the rig tuned properly for condition changes as the year progressed was key to *Oriole's* season, as was "having a very strong man on the main sheet who knows what to do and can call very close laylines."

1) *Oriole*, 27 points; 2) *Curlew*, Bill Claussen, RYC, 32; 3) *Widgeon*, Charles Rixford, RYC, 42. (7 boats)

Folkboat — *Polperro* Peter Jeal, BVBC

Peter Jeal's crew on the season-winning Folkboat included Susan Parker, his wife and jib trimmer/foredeck. "She has raced in 99.9% of all the Folkboat races since we joined the fleet in 1988!" said Jeal. "On the mainsail and everything else was the boatiest of boat sluts, Dave Kresge."

The highlight of *Polperro's* season: "Sailing to the Olympic Circle four times I think... the lowlight must have been the sail back on the ebb tide."

When asked what helped their overall position, Jeal replied: "I think the padded shorts helped a lot." He added, "Tom Reed came just a few points back behind us and Dave 'Slydog' Wilson missed a bunch of races that probably would have changed the eventual positions."



Susan Parker & Peter Jeal

1) *Polperro*, 22 points; 2) *Freyja*, Tom Reed, StFYC, 33; 3) *Windansea*, David Wilson, StFYC, 43. (9 boats)

Knarr — *Flyer* Chris Kelly, RYC

The crew aboard *Flyer* are Marc Bryan, Bob Gerlach, and Lief Wadleigh. "If there's a secret to our ability to find our way to the front of the fleet from time to time," said their skipper, Chris Kelly, "it's their willingness to stick with me over the years as we figured out how to make an old boat go well. They're the best!"

Kelly has been racing Knarrs since 1993, and before that he raced J/24s. "Racing the Knarr is the most fun I've had sailing — the fleet offers friendly yet intense competition in a boat that appeals to racers of all types and, thankfully, physical abilities."

The highlight of Kelly's season? "Racing in the 2014 International Knarr Championship in Bergen, Norway."

1) *Flyer*, 73 points; 2) *Gå*, Don Taylor, RYC, 93; 3) *Gjendin*, Graham Green, StFYC, 150. (20 boats)

INTERNATIONAL ONE DESIGN (IOD) — 1) *Fjaer*, Richard & Mark Pearce, SFYC, 50 points; 2) *One Hundred*, Paul Zupan, SSS, 55; 3) *Xarifa*, Paul Manning, StFYC, 58. (4 boats)

Whereas the WBRA concerns itself with wooden one-design racing classes on San Francisco Bay, the OYRA's mission is to run PHRF races on the ocean waters outside the Bay. The OYRA season consisted of nine races with one throwout.

What's left of the YRA's ODCA (One Design Class Association) and HDA (Handicap Divisions Association) joined forces to race in YRA's Spring Series and Summer Series this year.

OYRA PHRO1 *Elan*, Express 37 Jack Peurach, SSS

This was Jack Peurach's third season racing *Elan* in the OYRA series. "It was

YACHT RACING ASSOCIATION

ALL PHOTOS COURTESY THE WINNERS EXCEPT AS NOTED



LATTITUDE / ROSS

a blast, again," he said.

"We had a great crew this year — including Ann Hadley, Brent Piercy, Scott Davidson, Ben Westenburg, Mike Dooley, and Rebecca Hinden. Many of the crew have been sailing together for a few years now, and we're very familiar with the boat, which makes a huge difference.

"We had much lighter conditions than usual this season, which made tactics and boat speed concentration really important."

The Half Moon Bay Race topped Peurach's list of season highlights. "We

Jack Peurach



started in a building flood and just managed to get out. I think we were one of only a few boats that were able to escape the Gate before the tide took over. Luck was on our side, and we ended up with an overall win.

"The Drake's Bay race was also a blast, Even though light winds made

Chris Kelly's 'Flyer', the white boat in this photo, rose to the top of the knarryly competition in the 20-boat WBRA Knarr fleet.

the race up there a real challenge, the incredible beauty of the bay with all the boats anchored makes it one of our favorites.

"Although we had a great season, we did lose the SunPower cup — a side race we have with our friends on the Dogpatch 26 *Moonshine*, who race in a different division. Congratulations to Dylan and Zac for an equally great season and a couple of overall wins.

"We can't wait for next year! Hope to see a lot of boats out there again."

1) **Elan**, 17 points; 2) **CruzSea Baby**, Beneteau First 10R, Brian Turner, SCYC, 29; 3) **Maggie**, C&C 37/40R, Dave Douglas, BYC. (14 boats)

OYRA PHRO2 Whirlwind, Wyliecat 30 Dan Benjamin, OYC

Dan Benjamin has been sailing *Whirlwind* for five seasons. Last year, he won the SSS Singlehanded Monohull Season. This year he moves up from 2013's second place in OYRA's PHRO2 division, itself an improvement over 2012's third

place. Crew includes wife Carol, Dana Rowley and Darrel Lager.

The season's highlight was the competition for the championship. "Four boats were within striking distance of the overall win going

into the last race of the season," said Benjamin. "Even though we had been in the lead for part of the series, it was a must for us to do well in that last race — no bridesmaid outcome again. We played the currents and covered the other boats. We also learned something new about the performance of the Wyliecat 30 on the reach back into the Bay."

The Farallones Race was the low point of *Whirlwind's* OYRA season. "We stuck out the light air all the way to the far southwest corner of the island. We could see around to the north, but had no wind and retired, then had a 30-mile motor home. I had a total of three tries



Dan Benjamin

SEASON CHAMPIONS, PART II —

at the Farallones this season and never got around in any race. That has to be a record for me as skipper."

Key to *Whirlwind's* success was avoiding going the wrong way. "When you go out the Gate, you have to have a well-thought-out game plan. Stick to it, but don't be afraid to modify it as necessary. We did our share of chasing others who appeared to be doing well, only to learn that we had gone the wrong way."

Bejamin's plans for next year include more OYRA and SSS, Jack Frost Mid-winters (Wyliecat 30s have a one-design class), Vallejo Race, and OYC club races.

1) **Whirlwind**, 20 points; 2) **Starbuck**, Black Soo, Stephen Buckingham, SSS, 23; 3) **Ahi**, Santana 35, Andy Newell, BYC, 23. (9 boats)

OYRA Multihulls *Raven, F-27*

Truls Myklebust, BAMA

Truls Myklebust bought *Raven* in 2012 and brought her to SF Bay (the boat had previously been in Washington and Idaho).



LATITUDE / CHRIS

Truls Myklebust

"I had some work to do to get her up to the full off-shore racing equipment requirements," he said, "and I eventually ran the first ocean races with her last year before going for the full OYRA series this year."

"I'm very excited about the OYRA multihull division win, even though there were only two boats that contested the full series." He sailed the OYRA series mostly doublehanded and had Andrew Muff, Richard Theron and Richard Vilvens aboard for different races.

In addition to the OYRA series, Myklebust raced in the SSS series (he placed second in Singlehanded Multihulls), plus Rites of Spring and Delta Ditch Run with one of his 10-year old twin daughters as crew, and the Doublehanded Farallones.

"I really enjoyed this year's racing. We had a mostly trouble-free season on *Raven*, but we would have liked windier conditions offshore for most of the races.

Some standouts: "The OYRA Full Crew Lightship race. We had a glorious finish in beautiful, windy conditions (23 knots gusting to around 30) coming in through the Golden Gate at very high

speed with the spinnaker up — just as the Clipper Round the World Race 70-footers were making their way out. As we finished that race, we also had the scariest moment of the season: We jibed just after crossing the finish line at St. Francis YC, and the spinnaker halyard snapped just as the spinnaker filled on port tack. The spinnaker dropped into the water and immediately turned into a sea anchor, forcing us into an involuntary jibe back onto starboard toward land. We had a very close encounter with the sea wall, but thankfully managed to escape without making contact.

"The Drake's Bay Race (a joint OYRA/SSS event this year) also stands out. Winds were very light that weekend, particularly on Saturday, and I finished at Drake's Bay in total darkness. But it was beautiful going up the coast, I saw lots of giant sunfish along the way, and it was great staying overnight at anchor.

"The two main disappointments this year were: 1) completely running out of wind in the OYRA Full Crew Farallones race when we were so close to the island, and 2) finishing just 15 minutes after the time limit in the almost windless SSS Vallejo 2 (after placing first on Saturday, any finish time on Sunday would have secured me the multihull win for the weekend)."

Myklebust has learned a lot about the boat this year. "I can't wait for next season!"

1) **Racer X**, 12; 2) **Transit of Venus**, Corsair 37, Rick Walton-Smith, BAMA, 18. (2 boats)

OYRA SHS 1 *Racer X, J/105* Mary McGrath, EYC

Mary McGrath's husband, Rich Pipkin, the usual skipper of *Racer X*, crewed in the Pacific Cup this year aboard

Don Ahrens' Farr 36 *Red Cloud* and was busy helping to prepare the boat, so McGrath took the helm, and, for the first half of the season, her crew was Skip Allan.

"It was a special gift to be able to race with Skip, who taught me a lot," said McGrath. "I have renamed him the 'wind whisperer'.

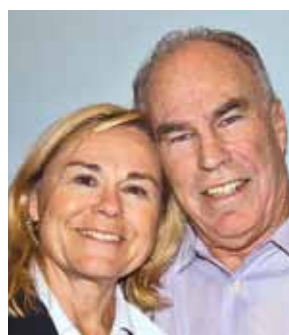

Mary McGrath & Rich Pipkin

LATITUDE / CHRIS

I swear he knows where it is coming from before the wind even makes up its mind."

Pipkin and McGrath purchased *Racer X* with a partner, Phillip Laby, in 2007 and raced one design with him for four years. Then they bought Laby's share in the boat and have raced *Racer X* in the OYRA series for four years. They won their shorthanded division in 2013 and 2012.

"This was my first year skippering the boat," said McGrath, "and the learning curve was steep, but I had two really good mentors in Skip and Rich. Skip and I had one particularly nasty spinnaker wrap — brought on by the South Tower demon — which the race committee commented on as a 'clever way to trim the spinny in high winds.'"

"A skipper can't really go wrong with crew like Skip and Rich, so the decks were a bit stacked in my favor. Rich may never get the wheel back!"

The couple are looking forward to next year and would love to see more shorthanded boats on the line. "Remember — it only takes *two* sandwiches and there's more beer to go around after the race!"

1) **Racer X**, 11; 2) **Void Star**, SC40, James Murphy, SSS, 18; 3) **Zsa Zsa**, 1D35, Stan Glaros, CYC, 21. (7 boats)

OYRA SHS 2 & YRA Spring Series, PHRF 2 *Nancy, Wyliecat 30* Pat Broderick, SSS

Pat Broderick won his division in two YRA series in 2014, OYRA and the YRA Spring Series.

"This year's OYRA Season was a mixed bag for *Nancy*," he writes. "It started out with strong wind, slumped in the middle when a broken boom prevented us from sailing the Half Moon Bay Race, then finished with light wind and a nail-biter conclusion. Because we missed the HMB Race, we needed to do well in the remaining ones in order to beat our perennial nemesis, *Moonshine*. Things were looking good up at Drake's Bay after we finished first, but not very hopeful in Sunday's race back when we finished dead last. We needed to win the last two races and have *Moonshine's* mast fall off. None of that happened. We were beaten by 21 seconds in the final race, but *Moonshine* finished last. That tied our scores at 16. We each had four first places, but *Nancy* had two seconds to *Moonshine's* one. It was a hard-fought series against worthy competitors."

Crew for OYRA included Barbara

YACHT RACING ASSOCIATION



Pat Broderick – circa 1976

McVeigh, Pat Wertz, Ross Bliven, John Kearney, and Michael Andrews, "a long list for a nine-race doublehanded series! Each contributed greatly to our win."

Broderick entered the YRA Spring Series "to give my beer can crew a chance to sail some longer buoy races, but things didn't work out exactly as planned."

They got off to a great start with the Knox-Bonita Race. "We held off the spinnaker boats on the long run back in for first place. Things continued on track with the second race day on the Olympic Circle, where we got two more bullets around the buoys on a lighter air day. Things were looking very good overall. Ah, don't get too smug too early!"

"Next was the third, and final, race day at Southampton. The first race was a total ball-up. Three different regattas were being run that overlapped each other's courses, with a mine field of temporary buoys scattered around in 35+ knots of wind and a strong ebb. So many boats sailed the wrong course that Race 1 that day was tossed out. In the second race, a twice-around windward/leeward course proved to be disastrous. Our second rounding of the weather mark in 38 knots of wind ended with a broken boom and a boatload of water. Our racing day was over."

"But with five races scheduled, the tossed out Southampton race, and our highest-point race deducted, we ended up with three bullets for three races."

Crewing on *Nancy* in the Spring Series were Leslie Wallach, Linda Hynes, Karen Brenner, Randall Lesley, Garland Sloane, Pat Wertz, and Ross Bliven. "They certainly got more excitement of various kinds than they ever did sailing around Richardson Bay in a Sausalito YC Tuesday night!" said Broderick. "Winning was just icing on the cake."

OYRA SHS2 – 1) **Nancy**, 16 points; 2) **Moon-**

shine, Dogpatch 26, Dylan Benjamin, RYC, 16; 3) **Iniscaw**, Martin 32, Max Crittenden, SSS, 19. (6 boats)

YRA SPRING SERIES (4r,1t)

PHRF 1 – 1) **Mintaka 4**, Farr 38, Gerry Brown, 3 points; 2) **Ahi**, Santana 35, Andy Newell, BYC, 6; 3) **Kind of Blue**, 1D35, Steve Saperstein, RYC, 7. (5 boats)

PHRF 2 – 1) **Nancy**, 3 points; 2) **Califia**, Islander 36, Tim Bussiek, SSS, 6; 3) **Mimicat**, Hinckley 38, Robert Long, Carolina YC, 7. (4 boats)

SANTANA 22 – 1) **Oreo**, Garth Copenhaver, SSS, 4 points; 2) **Byte Size**, Anna Alderkamp, TISC, 9; 3) **Tackful**, Frank Lawler, NoYC, 12. (8 boats)

OLSON 25 – 1) **American Standard**, Bob Gunion, BYC, 6 points; 2) **Synchronicity**, Steve Smith, HMBYC, 7; 3) **Shadowfax**, Mark Simpson, LTWYC, 8. (5 boats)

YRA Spring Series & Summer Series, PHRF 1

Mintaka 4, Farr 38
Gerry Brown, BYC

Gerry Brown is no stranger to these pages. A skipper on San Francisco Bay for 51 years, he's been the Triton champion six times, Newport 30 champ eight times, and HDA champ 10 times. He's owned the 1979 New Zealand-built *Mintaka 4* since 2000.

"Gari Ruggles (four years on this boat) crewed for me in the sixties on a Columbia 5.5 and a Triton," said Brown. Bruno

Carnovale has crewed with him for 32 years, Joe 'Rocky' Rockmore for 26, Henry Melin for 31, Donald Inouye for four, and Bob Gardner for 11 years.

"The average age of my crew is 71, proving that stealth, cunning, and treachery will beat youth and skill any time," said Brown. "We also keep our strength up with good food and wine."

"Sometimes I think my crew is an unfair advantage. Even the ones that have only been with us a few years have well over 20 years' experience. We make very few mistakes and have very consistent boat speed."

"Things have been harder since our rating was adjusted by nine seconds per mile. We have raced this boat with PHRF ratings ranging from 93 to 78."

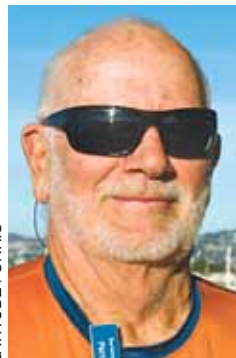

LATITUDE / CHRIS

Gerry Brown

YRA Summer Series, PHRF 2

Shameless, Schumacher 30
George Ellison, BYC

Shameless has been plying SF Bay race courses since 2006. George Ellison can be found on the foredeck. His boat partner, Harry Macartney, does pit, Axel Mehnert drives, and Ken Janke, Celeste Mirassou, and Thorsten Lill trim the sails.

The lowlight of Ellison's season was



Harry Macartney & George Ellison

missing the Great Vallejo Race and several others because he was working in San Diego. "The highlight was a great day against Gordie Nash in the YRA Season Closer. *Arcadia* won, but what fun to have two good crews sparring like that — good tactics and crossings, and it really came down to who guessed the lifts correctly."

Ellison says that the biggest factor in winning is "having the boat on the line, in good shape every race, and solid crew work. We drive the boat and ourselves hard, but have fun doing it. I'd also recommend a good knowledge of the latest Rules of Racing and interpretations."

YRA SUMMER SERIES (6r,1t)

PHRF 1 – 1) **Mintaka 4**, 7 points; 2) **Ahi**, 12; 3) **Centomiglia**, Flying Tiger 10, Mark Kennedy, RYC, 13. (6 boats)

PHRF 2 – 1) **Shameless**, 13 points; 2) **Califia**, 23; 3) **Kapai**, Islander 36, Richard Egan, SSS, 23. (7 boats)

SANTANA 22 – 1) **Oreo**, 7 points; 2) **Byte Size**, 7; 3) **Carlos**, Jan Grygier, RYC, 16. (8 boats)

CAL 20 – 1) **Can O'Whoopass**, Richard vonEhrenkrook, SFYC, 8 points; 2) **Coyote**, David Gardner, SSS, 9; 3) **Raccoon**, Jim Snow, CYC, 24. (3 boats)

We'll conclude our trio of features about 2014's season champions in January with the SSS and BAMA, plus another collection of one designs.

— latitude / chris

THE LATITUDE 38 INTERVIEW

Mike & Annette Reed

You're probably familiar with the old saw that "cruising is repairing your boat in exotic places." For the last eight years, Mike and Annette Reed of Santa Barbara have been traveling around parts of Asia, the Western Pacific and Eastern Pacific aboard their 46-ft cat Rum Doxy. But maybe we shouldn't describe what they've been doing as 'cruising', because instead of repairing their boat in exotic places, they've been building her in exotic places. It's the kind of thing that happens to people who go to UCSB for university, become harbor rats, migrate into medical professions, and dream of cruising distant waters.

38: What's your sailing background?

Mike: I grew up in L.A. and came to Santa Barbara to go to school at UCSB. I ended up living in the yacht harbor for 35 years, first aboard my 26-ft Seabird yawl for 10 years, and more recently aboard my, now our, Catalina 30 *Coyote Angel* for 20 years. Those boats were terrific 'island assault vehicles', and I spent a lot of time at San Miguel, Santa Rosa and particularly Santa Cruz Island. Although I was a commercial diver for a bit, I hiked almost every square foot of those islands. I did a lot of surfing, too. My favorite break was at Santa Cruz Island, but it gets so packed out there these days that Santa Rosa is better.

38: How old are you and do you still surf?

Mike: I'm 56, and was out surfing a good south swell just two days ago.

38: What about you, Annette?

Annette: I went to UCSB at the same time, and Mike and I were both young harbor rats in the early 1980s.

38: Is that when the two of you got together?

Annette: No, but that's kind of a funny story. While going to school way back then, I used to cruise the Santa Barbara Yacht Harbor in my Laser looking at all the boats. Then a boyfriend and I cruised to Mexico, but that didn't work out, so I was out of sailing for a long time. In 2002 I bought a Nauticat 45 in Seattle, which is a monohull with a wonderful salon that offers a 360-degree view, and brought it down to Ventura. I got out of the relationship I was in but kept the boat — even though it was too big for me to handle alone. One day a girlfriend and I were discussing my situation, and she said she knew of a nice

him in the early 1980s.

So Mike and I decided our first date would be a daysail on my Nauticat 45. Mike was very enthusiastic, because not only was he single, but the woman he was going to go out with had a Nauticat 45. For decades he's dreamed of having a cat, but didn't realize that despite its name, a Nauticat is a monohull. He was so disappointed when he found out. [Laughter.] It got worse, because the last time I'd gone sailing I almost sank the boat and had immersed the engine. So the engine wouldn't start. Mike got to spend six hours of our first date trying, in vain, to get the diesel going. So no cat and no sailing for him.

Our first successful date was a 10-day sailing trip to San Miguel, Santa Rosa and Santa Cruz Islands, and we've been together pretty much ever since. I sold the Nauticat a few months later, and we moved aboard his Catalina 30 *Coyote Angel*. While I had my hooks in him, we didn't get married for another six years.

38: So you both were at UCSB in the early '80s? You missed the tragicomedy of UCSB in the late 1960s and early 1970s by about a dozen years. The burning down of a Bank of America in Isla Vista, mobs of students being chased in vain through the night by overweight old cops, the 'liberating' of the university. Trust us, it would be difficult to overstate the pleasures of being young and idealistic at UCSB during that era.

Mike: [Laughter.] We're sorry we missed it. But living aboard in the Santa Barbara Yacht Harbor in the early 1980s was a hard gig to beat. I did some commercial diving, worked on boats with people like Marty Spargur, then went to school to be a paramedic. I did that for 11 years, then decided to go to medical school in the Eastern Caribbean.

38: Which island and what school?

Mike: Ross University on Dominica. It was a blast! Dominica is a beautiful island that isn't all touristy like most of the others in the Eastern Caribbean.

38: The Dolly Lama, our Chinese friend from South Africa, and his wife Melissa, now retired from running everything from Gunboat catamarans to large powerboats, have an organic farm on a remote part of the windward coast of Dominica. They tell us the island is like the Garden of Eden, with such fertile soil, fruit falling off the trees and free for the taking. Stuff like that.

Mike: It's a great island. After finishing medical school, I was living aboard in Santa Barbara and commuting to Bakersfield about four days a week for my residency. For 30 years I'd wanted a bridgedeck catamaran, but with medical school loans to pay off and other expenses, I figured that I'd never be able to afford one. Or maybe I'd end up with something like a basic Wharram cat. But one day I was looking at boat porn on the



'Rum Doxy' anchored off Santa Barbara.

guy who was doing his medical residency in Bakersfield while living on a boat in Santa Barbara, and his name was Mike Reed. "I know that dude!" I replied. In fact, I'd had a crush on

Internet and came across an inexpensive but interesting-looking 46-ft cat in Phuket, Thailand. So I made an extremely low offer on her sight-unseen — and it was accepted!

38: Tell us a little about her.

Mike: She is 46 feet by 25 feet, and was supposedly designed and built by a guy named Capelli, who had worked for Jeanneau, and a group of French mechanical engineers. She's of composite construction using epoxy and Kevlar. The interesting thing about her is that the top halves of the hulls are mirror images of the bottom halves — they came out of the same mold. I guess the builders thought they'd save a lot of money by building just one mold instead of two.

38: Did she meet your expectations when you saw her for the first time?

Mike: No. As soon as we saw her, I realized that she was a piece of junk that we'd never want to own. She had so many problems.

There was some delamination in one hull, everything leaked, the windows were all cracked, the electrical and plumbing systems were no good, the engines were no good — she truly was a piece of junk.

Annette: And she was filthy! She had three or four different kinds of mold all over.

38: The usual poop in the toilet?

Annette: I don't think so, but more than just being disgustingly dirty, she was full of bugs. There were countless cockroaches and other bugs crawling all over the interior.

Mike: She was beyond hope. Having been around boats for 30 years, I knew better, but couldn't keep myself from making a ridiculously low bid — basically the value of just the rig. But it was accepted.

38: You have to be careful what you wish for, and even more so when it comes to boat reclamation projects, don't you?

Mike: [Laughter.] I made a short list of things that I thought needed to be done to be able to sail the boat back to California safely, where we would fix her up. [More laughter.] As it

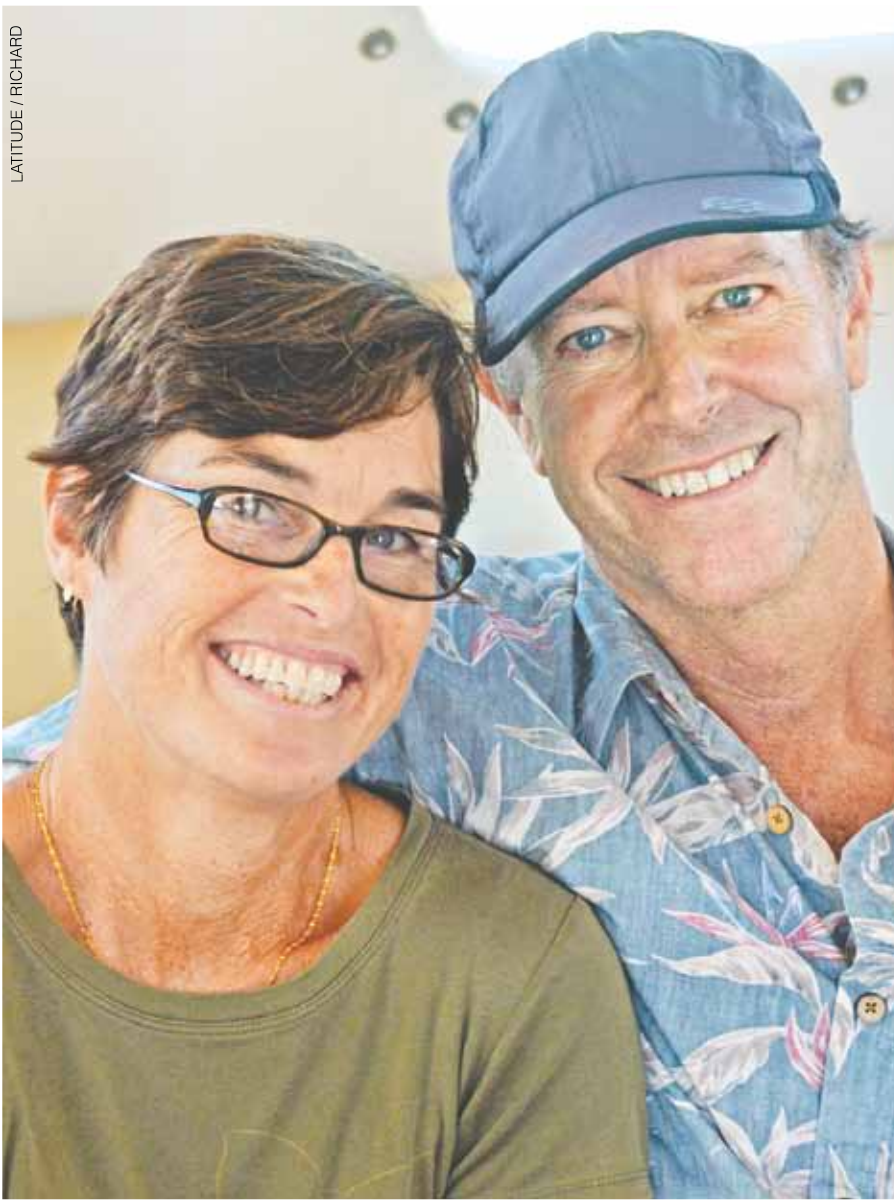

LATITUDE / RICHARD

The Reeds, Annette and Mike, aboard 'Profligate' in Santa Barbara.

turned out, we didn't get her out of the yard in Thailand for five years! During that period Annette and I would fly back and forth between Santa Barbara and Phuket every six months. We'd make money here in the States — Annette is an X-ray technician — then buy stuff, fly to Phuket, and work on the boat.

That it took so long to get the boat in the water was all my fault. For example, instead of just fixing a couple of bulkheads, I decided to replace them all. While I was at it, I thought I might as well do the crossbeam because of the termites, raise the bridgedeck, build a forward cockpit, do a new forward beam — and on and on and on.

Annette: Mike did all of the work. Every bit of electrical, plumbing, fiberglassing and carpentry. In addition, he did things like raise the bridgedeck because originally it was only 18 inches off the water, and give the forward part of the hulls more of a V-shape. Both of these things were done to keep the

cat from pounding miserably in a sea. The problem with making just one mold for both the hulls and decks is that what makes for a good deck doesn't necessarily make for a good hull.

Mike: The only original things left from the cat we bought in Thailand are the shell of the hulls and the aft crossbeam. The front crossbeam is new, the stern transoms are new, the Kubota 29-hp diesel engines are new, the engine compartments are new, the forward cockpit is new, the salon and aft cockpit are all new. And on and on.

38: Would it have been better to start out from scratch?

Mike: [Not quite maniacal laughter.] Absolutely! We should have done what our friend Jim Milski of *Sea Level* did. He bought a Schionning 49 kit from Australia and put it together in Vallejo. During the time we worked on *Rum Doxy* — and there's still some work to be done on the aft cockpit — Jim was able to finish his 49-footer and complete a circumnavigation with his wife Kent.

38: Even the most experienced sailors often underestimate the cost of bringing boats back or finishing them off. How

the latitude interview:

much more did it cost for you to finish *Rum Doxy* than what you originally paid for her?

Mike: Everything.

38: Huh?

Mike: Everything I made as a doctor has gone into the boat.

[Laughter.]

PHOTOS COURTESY RUM DOXY



'Rum Doxy' was not a pretty sight the first time the Reeds stepped aboard. There were four kinds of mold in the head, the wiring was a shambles, and the bulkheads had termites.

Annette: She would have been too expensive even if she'd been free. [More laughter.]

38: At least you know your boat better than all other boat-owners. Did you enjoy Thailand?

Mike: Yes, but spending that much time there redoing a boat is not something I'd want to do twice.

38: What boatyard did you do the work at?

Mike: It wasn't a single one. My goal was to leave money at every boatyard in Southeast Asia. I think I was successful.

38: Which yard was the best?

Mike: PSS Shipyard at Chebilang, Thailand, which is just a half day north of the big cruising center of Langkawi, Malaysia. The yard has half fishing boats and half yachts.

38: We were at the Langkawi International YC during a big regatta once. Some of the women serving satays and other food were wearing hajibs, but there was also a wild live rock 'n' roll band with a big light show, lots of people throwing each other in the pool, and free whiskey until 10 p.m. The exuberance and liquor sort of surprised us, what with Malaysia being a Muslim country.

Mike: It's sort of 'Muslim lite'. [Laughter.]

I should point out that one advantage of completing a boat from a shell is that it helps you appreciate conveniences. For example, when we finally got the boat wired with lights, we could just flick a switch and we would have light. After kerosene lamps, it was magical. Then getting water from a tap. Turn a

"We bought the cat in 2004, a month before the tsunami that killed 250,000 people."

knob and you get water? Fantastic! The steering, the engines — everything we added was something we truly appreciated.

Annette: For a long time it was like we were camping in the shell of a boat.

38: We went through much of the same drill when *Profligate*

was new. We did two winter seasons in Mexico with just one interior light. We didn't have proper bunks. The fuel tanks were bladders lying on the cabin soles. And we had little aluminum ladders to get up and down between the hulls and the bridgedeck.

Annette: We had those ladders, too!

38: So how long did it take to finish *Rum Doxy* enough to get her in the water?

Mike: We bought the cat in 2004, a month before the tsunami that killed 250,000 people in that part of the world, and launched her in 2010 as nothing but a shell with two new engines and steering. After she was in the water, we worked on her for three more years. Then we started sailing her back to California.

38: Tell us about sailing back.

Mike: After spending a few years in Langkawi, we continued on to Borneo in the fall of 2012, at which time the boat was mostly complete. In February 2013, we headed north to the Philippines, getting ready to sail across the North Pacific.

38: How did you like the Philippines?

Annette: The Philippines will take your breath away! It's stunningly beautiful.

Mike: It's an amazing place to cruise. I can't believe that more people don't cruise there, as it's beautiful and the people were more friendly than anywhere that we've been. It's very inexpensive, too.

Annette: It's not as pretentious or commercial as Thailand.

38: What about typhoons?

Mike: That's the problem. But if you stay in Palawan, the southern part of the Philippines, which is also the most beautiful part, it's pretty much typhoon-free. And you're always just a day away from a hurricane hole. We just loved it there.

Annette: Then we continued up to Manila to provision. Customs really hit us hard, with all kinds of clearance fees, health certificates, quarantines and stuff like that. Manila and Subic Bay really stick it to you compared to the southern Philippines.

Mike: After Luzon we headed for Ishigaki, Japan, but ended up in Taiwan because of unfavorable wind and current. Taiwan turned out to be a great stop. In fact, everywhere we stopped the people seemed more friendly than the stop before. I've been to 45 countries, most of them by land, and have never had an anti-American experience. That includes going to Nicaragua during the hostilities down there. I've found reality to be so different from what the U.S. State Department tells us.

Anyway, we went north to Okinawa, and on our way to Shimizu, Japan, passed the islands that China and Taiwan are currently squabbling about. We had a big spotlight shone on us, and were asked what we were doing. I wanted to tell them we'd come to claim the islands for the United States [Laughter], but I was able to resist.

There is almost nothing written about cruising in Japan, so we got on Google Earth and started looking for marinas. We saw some yachts at Shimizu, so we thought to ourselves, "We bet we can stay there." As it turned out, they had no idea what to do with us. But the Japanese are so friendly — nobody can 'out-gracious' them. They adopted us and could not do enough for us.

38: That seems odd because of their anti-immigration policy. But we've heard the same thing from other yachties who have cruised there.

Mike: The Japanese made us feel like visiting dignitaries. They took us all around Yokohama, and even took us to meet Minoru Saito, who has sailed solo around the world eight times.

38: When it came time to cross the North Pacific, where were you headed and how did that turn out?

mike & annette reed

Mike: It was interesting, because it was going to be our first really long passage, and because I was still working on the boat, doing things like glassing the aft beam to the hull, until the day before we left. But we picked Vancouver as our destination. Three weeks into the passage, it had gotten really old because we hadn't seen the sun in three weeks.

Annette: It was rainy, cold, overcast and miserable. Everything inside the boat was soaking wet.

Mike: In three weeks we saw the moon twice, saw one star, and had two sunny days. In some ways the sunny days were the worst, because we went into a frenzy to try to dry everything out and fix everything that was broken while it wasn't raining. But almost immediately everything got soaking wet again.

Then one night I was at the nav station looking at the plotter, and I was getting discouraged that it was still another two weeks to Vancouver. But when I zoomed out on the plotter, I noticed that Dutch Harbor, the closest land, was only 400 miles away, albeit a little behind us. But Kodiak was only 650 miles away, pretty much in the direction we were going anyway because the Pacific High had come north, meaning we couldn't lay Vancouver if we tried. Plus we could fly the chute all the way to Kodiak, which we did.

Annette: Arriving at Kodiak after 35 days at sea was magical. We were cruising in the fog at 2 a.m. with the sun coming up, when the fog suddenly cleared and there was land! We were surrounded by 100 whales and lots of other wildlife. And it was 85 degrees, as Kodiak was having a heatwave in the middle of their warmest summer in 75 years.

Mike: We arrived on July 24, and had been sailing with one rudder since Day Four of the crossing. One of the seals on a hydraulic cylinder had gone bad, so we had to lock the port rudder for the crossing. It wasn't too much of a problem, although sometimes we'd find ourselves going in circles when motorsailing. The problem was a microscopic bit of corrosion on a cylinder. We'd gone three years and thousands of miles without a problem, and haven't had one since. But we put in a 3/8-inch push-pull cable to keep the rudders honest.

38: So what was your trip like from Kodiak to Santa Barbara?

Mike: Awesome. We got to Kodiak at the end of July. We had some repairs to do, so we spent 10 days there before making our way into Prince William Sound, where we saw all the Alaska stuff — spectacular glaciers, bears and moose. Next we did Glacier Bay and the Inside Passage. While Kodiak was having the warmest summer in nearly 100 years, and claiming to be "the northernmost Hawaiian Island," farther south they were having typical summer weather. That meant a lot of rain, a break, a lot more rain, a break, then a lot more rain. During our week in Glacier Bay we saw nothing but fog and otters. But it was still great. The Inside Passage was flat calm. It made me think of vertigo because the water was so flat and smooth that it reflected the constellations perfectly. You couldn't detect a horizon. And it was like that almost every night because most anchorages have 360-degree protection. In general, the farther north you go in Alaska, the nicer it is.

38: You must have had some bouts of rough weather from Alaska to Santa Barbara.

Mike: [Laughter.] We hardly had any sailing breeze from Alaska down to Vancouver, and we had to motor from Cape Flattery to Pt. Arguello, which is, as you know, just 11 miles north of Pt. Conception.

The worst weather we had — and we expected it — came from the lows coming off Asia as we were leaving Japan. We ran from one post-tropical cyclone, but it caught us with winds to the high 40s and low 50s, fortunately from aft. But even with just one rudder our cat was great under autopilot. When it gusted

to 50, *Rum Doxy* would plane under bare poles. Even though she was under complete control, we decided to set our series drogue. It worked really well. In fact, I set it then just went to sleep for a few hours. Fortunately, the strong winds only lasted a couple of hours and there hadn't been any time for the seas to build.



No matter if he was on his back or knees, Mike did a lot of grinding.

38: Tell us why you added a boom for the jib.

Mike: It was an evolution, because originally the boat didn't have a forward cockpit, something that I added.

38: Gunboats notwithstanding, a forward cockpit seems like the nuttiest idea in the world to us.

Mike: It's the greatest thing ever! We wouldn't get another boat without it. It's the ultimate in prevention of people going overboard, because you're hip deep in a well at the point of the least motion and are 'wearing' the boat like a pair of pants.

38: Except on cats with too-low lifelines — of which there are many — we don't think there is much danger of going overboard. Our concern would be not being able to get to the sail controls quickly in the case of potentially flipping, what with having to open the front door to go out and throw off sheets.

Mike: In the case of the Atlantic 57 that flipped in the South Pacific, I believe they had too much sail up. If I understand it



Left, 'Rum Doxy' at Malaysia. Right, Annette in the beautiful Philippines.

correctly, they were outside when they were hit by 62 knots. But instead of letting the main go, they were messing around trying to furl the jib. I think it was operator error. But we can get to all our sail controls and throw off the clutches very quickly. And it's really dry.

the latitude interview:

Annette: We only took one bucket of water in the forward cockpit the whole time, and that's when it was really rough and I just had to get a photo of Mike, who was straddling a bow at the time.



Left; The doctor 'gloves up' and gets ready to operate on 'Rum Doxy' in another exotic location. **Right;** A curious spectator.

Mike: In any event, we are very conservative when it comes to setting sail. People laugh at us because even in mild weather we might have a second or even third reef. We got rid of the first reef. We like to sail at seven or eight knots. When the boat gets

over 10 knots it's hard to read a book and do other things.

38: That might have something to do with your cat's being so light and thus lively.

Mike: Back to the jib boom. Originally there was a track across the front of the cabin, but the angles were all wrong, and I tended to find myself in the 'zone of death' all the time. In addition, I didn't like the forces on the cabin or the angle on the cars. So I had a boom made for next to nothing — \$300 — in Thailand. Welding and metal work is inexpensive there. Now we have a slightly smaller jib than before, but thanks to the Catana mainsheet-style trimming, which uses two blocks, I have pinpoint control with two sheets but no fairlead cars. The triangulation is great, and the boom is actually solid to hang onto up forward.

38: Does it get in the way when flying a chute?

Mike: No.

38: Can you describe the difference between living aboard and sailing on a 26-ft Seabird yawl and a 46-ft catamaran?

Mike: It's a little different. The latter had full squatting headroom of 4.5 feet and nothing inside. The Catalina 30 was quite a bit better, but the cat is a palace by comparison. By the way, we still own the Catalina 30. We use her for storage and Annette waits there in the afternoon before we go out to *Rum Doxy* in the dinghy together.

38: End-ties are hard to come by and extremely expensive to buy the rights to in Santa Barbara. How do you manage?

Your Boatyard in the Heart of Paradise



Large, fenced, secure dry storage area

TAHITI CUSTOMS POLICY

Foreign Flag vessels can stay on dry storage in our yard for up to 12 months out of 24.

Our Services |

HAULOUT

- Marine Travelift 25 tons
- Marine railway 120 tons
- Storage in adjustable steel cradles
- Fenced Yard

PAINTING

- Topsides, hull, bottom, varnish
- Brush, roller, spray

MECHANICAL WORK

- Inboard, outboard, diesel, gas
- All brands

REPAIRS

- Electrical repairs
- Refrigeration installation & repair
- Fiberglass & woodwork
- Welding, steel, stainless, aluminum

SAIL LOFT

- Sail repairs, biminis, dodgers, covers

STORE

- International, Pettit, Epiglass, Devoe
- Spares
- Fill U.S. gas cylinders

DO-IT-YOURSELFERS WELCOME!

BoatUS Cooperating Marina



Professional boatyard in the heart of Paradise



Raiatea Carenage will make sure paradise is everything you expected. Call, write, or sail in . . . we're here to serve you.

B.P. 1111 Uturoa Raiatea 98 735 Polynésie Française

Tel: (689) 600-545 ~ Fax: (689) 600-546 ~ VHF 68

Web site: <http://www.raiatea.com/carenage> ~ email: raiateacarenage@mail.pf

mike & annette reed

Mike: We anchor out most of the summer, and it's just beautiful. Winter is more challenging because all the boats are required to move two miles down the beach.

Annette: We couldn't be happier, and I couldn't live on land again if you paid me. That said, in the winter the Santa Barbara anchorage is the worst of all the anchorages we've ever been in. It's horrible. I hate it! In the winter you get a combination of chop from the west and wind from the east, so even if you're on a cat, you roll like crazy. Anchoring off Santa Barbara in the winter is the worst ever.

Mike: We're probably going to take a slip at Ventura for the winter.

38: What are your plans for the future?

Mike: We plan to head south next fall. We'll spend a season or more in Mexico. We still don't have any money, so we'll probably spend the summers working on cruise ships or even bashing back up and working here. But we'll keep making our way south, maybe to South America.

Annette: I just love our cat, as she's our dream come true. It's my glass house, what with the eye level ports to look out and see nature.

38: While *Rum Doxy* doesn't have the biggest salon we've seen on a 46-ft cat, we have to say that for two people it looks extremely comfortable. We love the daybed and the second captain's chair/recliner. Indeed, we really wish we had something so luxurious on *Profligate*.



Two of 'Rum Doxy's more attractive features are: 1) The tremendous amount of light and visibility, and 2) The salon daybed.

Annette: The one benefit of living on a boat while you're building her is that you learn what you really want and get to make it that way.

38: Congratulations and thank you. Visit the Reeds' blog at www.sailblogs.com/member/rumdoxy for more on their adventure.

— latitude 38



At beautiful
Emeryville Marina
On The Bay

40' - 50' SLIPS NOW AVAILABLE!

- + 350 Floating Slips Dock Boxes/Power Outlets/Water
- + Private Restrooms and Showers for Marina Members
- + Private Laundry Facilities
- + Gas and Diesel Fuel Dock
- + Pumpout Station
- + Telephone and Wireless Internet

Professionally Managed By **MARINAS[™]**
International

Emeryville Marina

ON THE BAY

510.654.3716 | www.emeryvillemarina.com
3310 Powell Street | Emeryville, CA | 94608

It's the difference between a "lunch" and a "luncheon." At a classy luncheon, the serving crew never lets my water glass go below half-tank, and when I push off for another run at the buffet table I know my old plate will be history before I return. And there are two forks wrapped up in that cloth napkin. Meanwhile, back at my own club, our idea of a club lunch is a pot of canned chili and some sausage dogs served on paper plates. But at this luncheon, there's a choice of designer soups and at least one very credible hot entrée to complement the spread of sandwich fixings. And most important, a very impressive dessert table.

The bill for this "low-cost" meal, after they calculate the tip and add the tax, is \$26.43 per person. Proving again that everything is relative.

But I was not indulging in an upscale yacht club luncheon for the food, or for the view, or for the service, or to cross tacks with sailors who, on average, pour a lot more money into their holes in the water than I do. These events include a presentation, and that can be worth the price of admission alone.

"I've been sailing the Bay for years," I remarked to the older gentleman sitting next to me as I returned to the table with a second bowl of shrimp bisque and a plate of salad, rice and pork ribs, "and I

never even knew about the weekly luncheons and talks until just this year."

"That's because they used to be restricted to club members and their guests," he informed me. "Then we opened it up to members of any recognized yacht club. Attendance is finally coming back up, but for a while there, son, we were sailing in pretty shoal water."

I'm well into the old curmudgeon demographic at my own club, but in this crowd I can still be called "son" and it doesn't seem wrong.

There was only one empty seat left at the table, and I was pleased to see that it became occupied by a very attractive young woman in a conservative business suit. I stood up to help slide her chair in — a bit of chivalry that would seem out of character in any other setting — and it wasn't till she said "Like, thank you, Max," that I realized who had just joined us.

"Lee!" I stammered. "This is the last place I expected to see a starving grad student like you turn up for lunch... and the... the..."

"...the biz drag, for sure," she finished the sentence in a whisper. "I'm like, deep under cover in the corporate world during winter break."

It was the first time I had ever seen Lee in a skirt. I was amazed that she even owned one, let alone the rest of the outfit. She explained that she had a temporary full-time consulting project for a design firm in the city.

"That explains why you're on this side of the Bay," I said.

"And, like, it's a free lunch, too," she added, gesturing to another table. "I'm the guest of the owner of one of the big race boats I crew on, but there's no room left at his table."

After introductions all around, it came out that Lee was studying naval architecture at the University, and this prompted a series of technical questions about weather helm, hull speed, and hydrofoils.

"What a great deal for a kid on a tight budget," someone remarked when Lee left to make her first pass at the buffet.

"As long as the bill goes elsewhere," I noted. "The great thing about starving student sailors this time of year is that it's easy to figure out what to give them for Christmas. They need everything."

"My problem is just the opposite," complained the only other woman at the table. "My husband is a sailor who has everything, and I'm always at a loss to come up with a gift he'll appreciate."

"What does he usually buy for you?" someone asked.

"We usually go to the Caribbean over the holidays, and detour to Paris on the way back for shopping," she sighed.

"You could give him a really good photo of his boat, professionally framed," was one of the suggestions.

"Depends if that photo exists," said another helpful sailor. A lot of boats have never really been photographed looking their best, and this time of year, there's not enough wind for even the best photographer to set up a really great shot."

"Commission a painting, then," suggested another club member. "I know an artist who can work from a lackluster photo and make it look as if the boat's on a full plane under the bridge coming out of a fog bank. Really dramatic stuff — I think he's even sitting at that table over there..."

All agreed that it was a great idea, but that there was probably not enough time.

"Stabilized binoculars," I said. "Or, if he does a lot of ocean racing, one of the latest-generation night-vision scopes. Best to check with some of the crew first, though, to make sure those toys aren't

GIFT LIST FOR THE SAILOR WHO HAS (ALMOST) EVERYTHING

- *Modern Race Navigation: Expedition Software in Action* — The only book that adequately explains the top end of the art. Will Oxley, only available in electronic form; \$26.99.

- *The Models of the St. Francis Yacht Club* — If you have to ask, you can't afford this book by R.C. Keefe, Kimball Livingston and Chris Ray.

- *The Sea and Civilization: A Maritime History of the World* — Revisionist maritime history by Lincoln Paine. Kindle \$21.99, or hardcover \$27.79.

- *The Widow Wave: A True Courtroom Drama of Tragedy at Sea* — An engaging under-the-hood look at a major maritime lawsuit. Jay W. Jacobs; \$7.59 (Kindle), \$31.90 (hardcover), \$14.35 (paperback).

- SailTactics subscription, for the best

daily high-res wind forecasts on the Bay; www.sailtactics.com; \$20/month, \$90/6 months, 10% off on gift subs with discount code "MAXEBB."

- Gift Certificate for a luncheon and a lecture at a classy yacht club; www.stfyc.com (click "events"); \$26.43.

- Flat nylon webbing. The perfect gift if you sail on a boat with old, worn sail ties. Minimum length is eight feet for big boats, seven feet for small boats; \$0.70/ft.

- Protest Flag. Every tactician needs to carry one at all times, 18" x 12"; \$15.99.

- Digital watch with the critical rolling countdown feature, for new crew that keep showing up without

countdown capability. Timex Expedition; \$35.00.



A waterproof watch with an adjustable, repeating countdown timer doesn't have to cost a lot.

THE TED TALKS OF SAILING

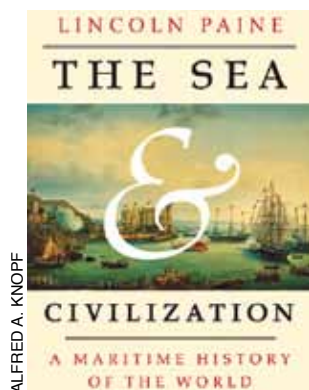
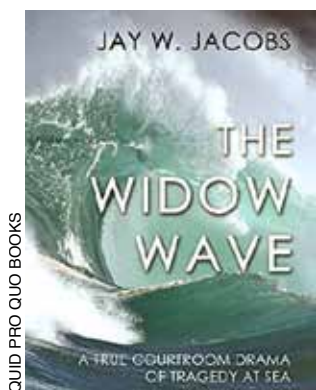

These are just three of the many printed and digital books available on diverse topics that might pique the interest of sailors this holiday season.

already on board."

"Another idea," suggested one of the older club members, "is that book that documents all the models on display here in the club. It should be on all of our coffee tables, if it isn't already."

The woman took a small pad from her purse, made a note in it, and seemed pleased.

"Back to more modest budgets," I said. "I need some gift ideas for my crew."

"There's the book written by that lawyer who spoke here a few weeks ago," said one of the club members at the table. "*Widow Wave*," I think it's called. A good read, especially if you think you might be involved in a civil suit involving a maritime loss."

Unfortunately Lee had just returned with her first plate of ribs, and so I was not going to get any ideas that would be a surprise to her.

"I read that book," Lee said as she started in on her first rib. "Thought there might be some new anecdotal data in it about rogue waves, but no luck. I agree it's a great read anyway, but, like, I had to take out my red marking pen before I got past page three."

"You found technical errors?" said the sailor who had recommended it.

"Does anyone here remember Avogadro's Number?" asked Lee.

"Six-point-oh-two times ten to the... what was it... the 23rd? But why..."

"Right! And like, you can't get through high school without passing chemistry, and you can't pass chemistry without knowing that number."

"I remember the number, but I totally forgot what it means."

"It's the number of molecules in the gram molecular weight of a gas."

No one had any idea why Lee would be spouting off about high school chemistry, but we could all see that barbecue sauce was falling on her white blouse.

"The author of that book describes an air mass over Siberia," Lee explained, "as consisting of 'billions' of air molecules. The average molecular weight of air is 29. That means that there are 6.02 times ten to the 23rd molecules in 29 grams of air. Do the math. A cubic millimeter of air at sea-level pressure had hundreds of billions of molecules — that's, like, what fits on a pin head — and he uses 'billions of molecules' to describe an air mass half the size of Siberia."

"Give the guy a break, Lee. He's just using 'billions' as a superlative, not a literal estimate."

"It gets worse, Max. On the next page he reports barometric pressure as 30.59 psi. PSI! He really means 'inches of mercury.' Atmospheric pressure at sea level averages 14.7 psi. And like, getting the units wrong is a real points-off error."

"Is she always like this?" asked the person sitting across the table from me.

I nodded. "I think she's been grading too many undergraduate assignments lately," I whispered. But Lee was not done.

"That's why experts think of lawyers the same way lawyers think of jurors," Lee quipped. "But the book is still a great read."

"So what's on your wish list these days, Lee?" I assumed she would deduce that I'd check her online wish list anyway, so there was no reason to pretend I could surprise her with anything.

"There's a book called *Modern Race Navigation*, by Will Oxley. I read the preface, and he scored points with me right away. First he says not to bother with your instruments unless they are really, really well calibrated."

"Amen to that," came a comment from across the table. "Any navigator who relies on inaccurate instruments will

make strategic errors. Or worse, he'll be ignored."

"Second," continued Lee, "Oxley stresses that for inshore races it's important to be able to do everything from on deck. No hiding out down at the nav station. Keep your handheld instruments with you, and set up deck displays or a wireless tablet or some other form of repeater for the more complicated outputs."

"My navigator needs to read this," said one of the other racers at the table.

"Buy it for him," advised Lee. "Only 28 clams for the eBook version."

"Good idea," he said, "but I think hard copy makes a much better gift. I like to have something to wrap up, with a physical presence and some heft to it."

"Sorry, it's only available as an e-Book," replied Lee. "But, like, that can be a plus for last-minute shoppers. You can have it arrive in email on Christmas morning, if you procrastinate that late."

"I heard that the book is really more like an advanced user manual for Expedition," said another old sailor in the group, "and not much use if the boat doesn't run that software."

"For sure," Lee agreed, "but still worth checking out even on a non-Expedition boat. It's full of new and important stuff never even mentioned by any other book on the subject."

"Lee, I'm curious what you usually buy for the people on your shopping list, considering your starving-grad-student budget."

"You have to get creative. If I have any good photos, an enlargement in a cheap frame is inexpensive and really appreci-

"It's important to be able to do everything from on deck. No hiding out down at the nav station."

ated. But when you sail on a boat you know what they need, and not all of it is pricey. For example the boat I race on now spends tons of money on new sails and everything else to make the boat go fast, but, like, our sail ties are an embarrassment. Threadbare bits of webbing or assorted pieces of old halyard tails. So I'm buying the boat 40 feet of webbing and making up five new eight-ft sail ties."

"I like it," I said. "Inexpensive, useful, and sends a message..."

"The best 'message' my crew ever sent me," remarked another retired racer, "was with crew shirts. I hadn't made

MAX EBB

any new crew shirts for several years, just hadn't gotten around to it, and the crew thought this was an inexcusable oversight on my part. So they had them made up themselves - really nice golf shirts, with the profile drawing of the boat on the back, the boat name and logo on the front, personalized with crew names. They were really well done and really pricey."

"Your crew did all this on their own, without your knowing about it?" I said, amazed.

"Wait till you hear what they did next. They all showed up for a race with these great shirts, and they wouldn't give me a single shirt unless I paid for all of them."

"Those dogs!" exclaimed another retired racer.

"Brilliant," said Lee as she scarfed down the last of the ribs on her plate.

This meant that Lee was about to make another pass at the buffet table, and it gave me another chance to consult with the hive mind for a good gift for her.

"There's that book by the maritime historian who spoke here two months ago," said one of the regulars. "I like

his revisionist theories so much that I memorized a phrase from his introduction: 'Taking Europe's "classic age of sail" from the sixteenth to eighteenth centuries as a model for the rest of maritime history is seductive but inadvisable.' That's the kind of historical writing that gets interesting.

"Another great gift idea," said one of the club members, "is a subscription to Mike Dvorak's SailTactics wind forecast. \$90 for six months, but it's far and away the best local wind prediction. He's got it down to 200-meter resolution with the best surface friction model in town."

"Didn't that guy also speak here a couple of months ago?"

"Yes, come to think of it. It was a good talk. These luncheons are beginning to feel like the TED talks of sailing."

"That's it," I said. "I'll give gift certificates for these luncheons to my crew. The price is in the right range, and they can use it up any time there's a speaker they're interested in."

"Do we do that?" asked one of the

longtime members, turning to the older woman at the table, who apparently had something to do with managing the luncheons.

"I don't see why we can't," she answered. "Of course, if the crew aren't members of a recognized yacht club they'll have to be someone's guest. And if Max isn't here that day..."

"I'm here every week," volunteered one of the older members. "Just let me know if you need me to host one of your crew. That is, as long as they don't all eat as much as Lee over there."

Lee was just sitting down again with another plate piled high with ribs, and a bowl of that shrimp bisque, too.

"What does the TED in TED talks stand for, anyway?" I asked.

"Trim, Ease and Drift," suggested one of the racers at the table. "It's for lectures about light air sailing."

"Talks with Exaggeration and Debate," said another regular participant.

"Tooheys Extra Dry. It's an Australian beer."

"Time to Eat Dessert," said Lee.

— max ebb

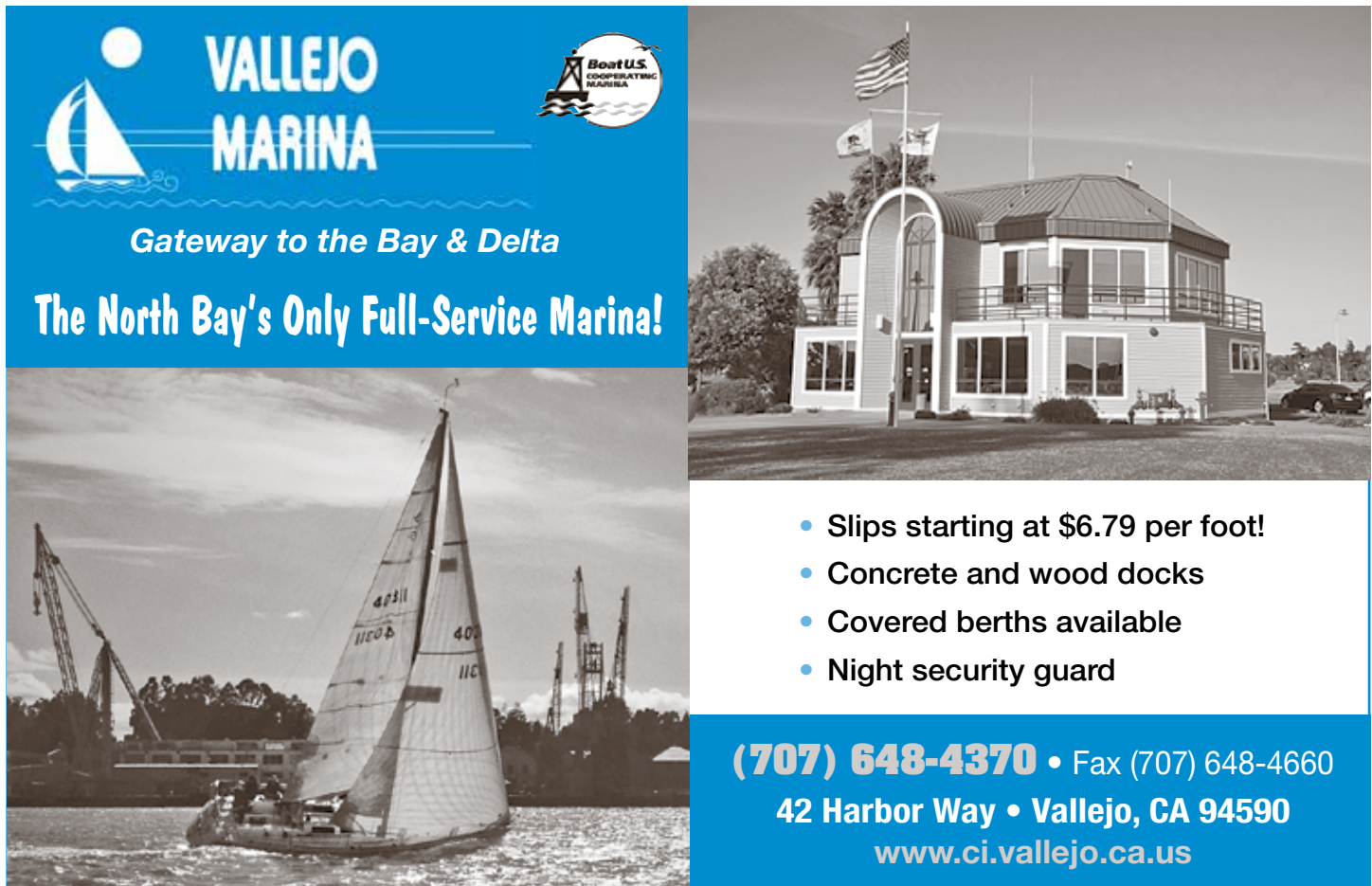

VALLEJO MARINA

Boat U.S. COOPERATING MEMBER

Gateway to the Bay & Delta

The North Bay's Only Full-Service Marina!

- Slips starting at \$6.79 per foot!
- Concrete and wood docks
- Covered berths available
- Night security guard

(707) 648-4370 • Fax (707) 648-4660
42 Harbor Way • Vallejo, CA 94590
www.ci.vallejo.ca.us

We are having a Winter Sale!
30% off bottom paint
50% off haul outs

- ★ Marine parts and supplies
- ★ Complete haul and repair
- ★ Engine repair and service

**marine services
for power & sail**

415.626.3275
 info@sfboatworks.com
 835 Terry Francois St.
 San Francisco, CA 94158

Authorized dealer for
YANMAR

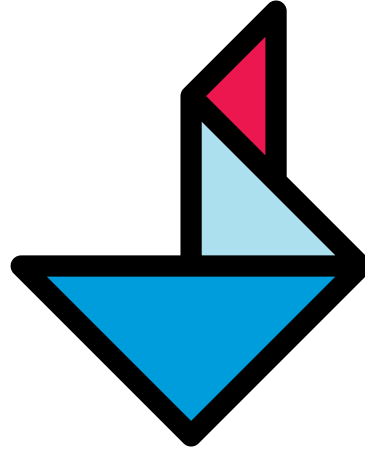

**SAN FRANCISCO
BOATWORKS**

San Francisco's boatyard | www.sfboatworks.com

HAWAII

LONG TERM DRY STORAGE

Clear Customs at our dock

GENTRY'S

KONA MARINA

HONOKOHAU HARBOR

156°1'30" W
19°40'20" N

TOLL FREE **888-458-7896**

www.gentryskonamarina.com

The friendliest boatyard in Hawaii

*Available
Now!*

**VOLVO
PENTA**

ENGINES • PARTS • SERVICE

1-800-326-5135



*Merry
Christmas*



(415) 453-1001
 FAX: (415) 453-8460
www.helmutsmarine.com
 619 Canal Street
 San Rafael, CA 94901

MARINE SERVICE INC

AUTHORIZED POWER CENTER

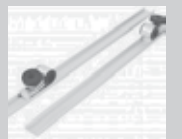

SLIDING PIVOT SUPPORTS
 Solar panel rail mounts,
 pivoting, adjustable slides



TEAK SEAT
 Teak seat, collapsible, fits
 straight rail or in corner,
 swing-down support leg



**COCKPIT TABLE MOUNTING
HARDWARE KIT**
 Lightweight, anodized
 aluminum, adjustable,
 collapsible, easily removable.
 Extra base plate to use
 the table in both cockpit &
 salon. Tabletop available
 in StarBoard, teak or make
 your own. Solar mounting
 hardware available, too.

HOTWIRE ENTERPRISES
www.svhotwire.com



Phone/Fax 727-943-0424
 e-mail: hotwiregam@aol.com

**OEM Wholesale
Sail Manufacturing**



*Hong Kong
Worldwide Delivery*

Fareastsails.com

Our Sails Catch Better Winds

THE RACING

The Route du Rhum broke boats and records on the way to Guadeloupe; the **Great Pumpkin Regatta** lived up to its name — and its reputation; St. Francis Yacht Club captured the **San Diego Lipton Cup**; we kick off a season of midwinter race reporting with the **Berkeley Yacht Club & Sausalito Yacht Club Midwinters** and **Winter One Design**; and San Francisco's BAADS Sonar Team Alpha scores a podium finish in the **U.S. Disabled Championship**. Plus we continue catching up on **Box Scores**.

The Run to the Rhum

The 10th edition of the Route du Rhum may be over, but it won't soon be forgotten. With a record-breaking fleet, both in terms of overall entries (91) and caliber of yachts entered, the race was hyped to the max yet managed to exceed expectations in every way. Taking place just once every four years, the singlehanded transatlantic race from Saint-Malo, France, to the Caribbean island of Guadeloupe is the only race with the media draw, public following and depth of competition to attract all the big classes and all of the big rockstars in French sailing; both solo specialists and other sailing celebrities made one-off appearances. With an interesting and diverse handicap division, a beyond-massive fleet of 43 Class 40s, nearly a dozen Multi 50 trimarans, nine IMOCA 60s and eight maxi-trimarans present at the start in the historic Breton port of Saint-Malo, the Route du Rhum is arguably the greatest spectacle in all

of sailing, the America's Cup included. The big questions before this Route du Rhum mostly revolved around the 'Battle Royale' that would be the Ultime division of maxi-trimarans. Could the legendary Loïck Peyron fill injured Armel Le Cléac'h's shoes on the 103-ft *Banque Populaire VII* with just two months to prepare? Could Yann Guichard singlehandedly sail his 140-ft *Spindrift 2* (ex-*Banque Populaire V*), the fastest offshore sailing vessel ever built, to its potential and claim victory? Would Thomas Coville's heavily-modified, newly launched *Sodebo Ultime* (ex-*Geronimo*) reign supreme in its debut, having been rebuilt from the ground up as a solo rocket? With three light and nimble MOD 70s entered alongside Francis Joyon's venerable *IDEC* and race record holder Lionel Lemonchois at the helm of *Prince de Bretagne*, the Ultime division was possibly the most highly-anticipated and intriguing solo race across the Atlantic of all time.

Departing from Saint-Malo on November 2 in post-frontal westerlies, the fleet immediately sailed into big breeze and seas on the English Channel and the Bay of Biscay that quite literally wrecked much of the fleet, creating mass carnage and abandonments. In the first two days alone, two Class 40s lost keels, the Multi 50s left a trail of daggerboards and rudders across the Bay of Biscay, and Thomas Coville on *Sodebo Ultime* hit

a cargo ship at close to 40 knots combined speed. He was forced to abandon the race. In all, more than two dozen boats dropped out of the race for various reasons, including pre-race IMOCA contender Vincent Riou on *PRB*, more than half of the Multi 50 fleet, 11 of the Class 40s, and a third of the 'Rhum' division. Of course, that's almost par for the course in an ocean race that crosses the notorious Bay of Biscay in November.

After completing the 3,542-mile course, all of the pre-race questions were answered one after another. In the Ultime division, Loïck Peyron continued to cement his status as one of the all-time greats by stepping in and winning the Route du Rhum aboard *Banque Populaire VII*, setting a new course record of seven days and 15 hours, just two hours under Lionel Lemonchois' eight-year-old mark and some 14 hours ahead of *Spindrift 2*. In the IMOCA division, Vendée Globe champion François Gabart on *Macif* went out on top with a popular win and course record, while Spaniard

Spread: The 103-ft '*Banque Populaire VII*' (ex-'*Groupama 3*') broke the Route du Rhum record on November 9 with a replacement skipper onboard. Loïck Peyron took over from the injured Armel Le Cléac'h. Inset: Thomas Coville tangled with a ship on '*Sodebo*'. The first few days took a heavy toll.



Alex Pella earned a hard-fought win in the hugely competitive Class 40 division.

For more, see www.routedurhum.com.

— ronnie simpson

Great Pumpkin Regatta

The conditions for the buoy races in Richmond Yacht Club's Great Pumpkin Regatta on Saturday, October 25, were windy and sloppy, as a brisk southerly blew in with a storm system. Three races each on three courses in the Southampton Shoal/Berkeley Circle area got up to 15-18 knots of wind with gusts above 20. The rain held off until after the boats returned to the docks. "A few boats were missing, but they missed a good day," said Fred Paxton, PRO of the Southampton course.

To aid in the transition from serious racing to serious partying, Herman Munster trolled around in a Whaler handing out candy to the racers as they returned to the RYC harbor. A Halloween party ensued, with many excellent costumes inspired by this year's theme of old horror movies. The band Shark Sandwich packed the dance floor until the curfew of 10:00 p.m., after which a few diehards wandered out to the Farr 52 *Zamazaan* to continue the party. From 10:45 to 11:15, RYC's vice commodore Craig Perez walked the docks, flashlight in hand, to make sure no one had gone for an unexpected post-party swim. Some of

NICOLAS DERNÉ / AFP



The Route du Rhum Ultime class podium: Loïck Peyron, '*Banque Populaire VII*', first; Yann Guichard, '*Spindrift 2*', second; and Sebastien Josse, '*Edmond de Rothschild*', third.

of sailing, the America's Cup included. The big questions before this Route du Rhum mostly revolved around the 'Battle Royale' that would be the Ultime division of maxi-trimarans. Could the legendary Loïck Peyron fill injured Armel Le Cléac'h's shoes on the 103-ft *Banque Populaire VII* with just two months to prepare? Could Yann Guichard singlehandedly sail his 140-ft *Spindrift 2* (ex-*Banque*



BOTH PHOTOS THIERRY MARTINEZ

the *Zamazaan* crew joined in and helped check the two last docks.

Sunday's pursuit race started with the 'slowest' entry in the 158-boat fleet, Richard vonEhrenkrook's Cal 20 *Can O'Whoopass*, at noon under a clear sky. A northerly breeze, brisk in the late morning, had softened by then. The course takes the fleet from a startline near Southampton Shoal around Angel Island and Alcatraz — in either direction. This year's finish near the Richmond harbor thankfully skipped the turning mark and short upwind leg that created so much havoc — and damage — last year.

The clockwise boats were able to fly spinnakers to Alcatraz, but there they ran into a giant wind hole, where they were in danger of running into each other — or the Rock. For better or worse everything happened in slow motion. While enjoying more of each other's company than they would have liked, the drifters watched the counterclockwise boats begin trickling through, riding the still-flooding current. John Kernot's Moore 24 *Banditos* was the first counterclockwise boat to reach Alcatraz, followed by Jennifer McKenna and Fred Paxton on her Santana 22 *Zingaro*. A westerly finally filled in around 2:00.

The first boat to finish in the tricky conditions was Scott Easom's Farr 30 *Eight Ball*, which also won the race in 2010,

the year Easom got the boat.

"This year the plan from the start was to go counterclockwise, and that turned out to be the right move — this time," said Scott. "I thought we could hug the Angel Island shore with a north breeze and stay out of the flood. That's what happened, and we were able to ride the flood through the hole at Alcatraz and into the northerly on the east side. I'm wrong more times than I'm right, and that's what makes it so much fun!

"Other people went our way, but I had the right boat for the day and the right crew for any important race. They always do such a great job, and they're the guys who make it happen. The crew was Matt Siddens, Ernie Rodriguez, Gunnar Torre, Gary Sadamori, and — all the way from Tahoe — Radar Felton.

"Shout out to the little Moore 24 that was the last boat we passed half a mile before the finish — they sailed a great race too." That second place boat was John Kernot's *Banditos*.

Bill Erkelens, Sr.'s D-Class catamaran *Adrenaline* was both the first clockwise boat and the first multihull to finish. "Counterclockwise was the 'right' way to go for the early starters," he opined, "but not for the late starters." *Adrenaline* started at 1:11.

"Winning" the dubious honor of last boat to finish was Tony Bourque's Newport 30-II *Now & Zen*. "We were eating

and drinking and enjoying the scenery," he explained.

"Thanks to Nancy Pettengill," said PRO Eric Arens, "the crew on the two finish-line boats, *Pelican* and *Doghouse*, were excellent recorders and scored all the boats."

— *latitude/chris*

GREAT PUMPKIN REGATTA, RYC, 10/25 (3r, 0t)

OLSON 25 — 1) **American Standard**, Bob Gunion, 6 points; 2) **Balein**, Daniel Coleman, 6; 3) **Shadowfax**, Mark Simpson, 9. (4 boats)

CAL 20 — 1) **Can O'Whoopass**, Richard vonEhrenkrook, 3 points; 2) **Invader**, Byron Jonk, 7; 3) **Coyote**, Dave Gardner, 11. (5 boats)

EXPRESS 27 — 1) **El Raton**, Ray Lotto, 5 points; 2) **Peaches**, John Rivlin, 6; 3) **Wile E Coyote**, Dan Pruzan, 8. (10 boats)

J/70 — 1) **Bottle Rocket**, David Schumann, 5 points; 2) **DFZ**, Tom Jenkins/Eric Kownacki, 6; 3) **Jennifer**, Chris Kostanecki, 9. (6 boats)

J/105 — 1) **Javelin**, Robert Goosey, 3 points; 2) **JuJu**, Tim Sullivan, 4; 3) **Yunona**, Artem Savinov, 7. (4 boats)

J/111 — 1) **MadMen**, Dorian McKelvy, 2 points; 2) **Aeolus**, Rob Theis, 5; 3) **Bad Dog**, Richard Swanson, 5. (5 boats)

MELGES 24 — 1) **Personal Puff**, Dan Hauserman, 4 points; 2) **Insolent Minx**, Zhenya Kirueshkin-Stepanoff, 5; 3) **Simplicity**, Stephen McMillan, 5. (5 boats)

SANTANA 22 — 1) **Alegre**, Chris Klein, 3 points; 2) **Carlos**, Jan Grygier, 6; 3) **Byte Size**, Thyjs Kaper, 9. (9 boats)

ULTIMATE 20 — 1) **UAgain**, David Woodside, 4 points; 2) **U Decide**, Phil Kanegsberg, 9; 3) **Salsa**, David Krausz, 10. (6 boats)

WYLIEMAT 30 — 1) **Uno**, Steve Wonne, 3 points; 2) **Whirlwind**, Dan Benjamin, 6; 3) **Crinan II**, Don Martin, 10. (4 boats)

WYLIE WABBIT — 1) **Weckless**, Tim Russell, 4 points; 2) **Bad Hare Day**, Evelyn Ivey, 7; 3) **Mr. McGregor**, Kim Desenberg, 7. (5 boats)

SPORTBOAT — 1) **Gentoo**, Soto 30, Paul

For more racing news, subscribe to 'Electronic Latitude online at www.latitude38.com

November's racing stories included:

Volvo Ocean Race • Butler Cup
Rolex World Sailor of the Year Awards
GGYC & SBYC Midwinters
Halloween Invitational Match Race
The Big Sail • Around Jamestown Record
San Diego's Pitch for the America's Cup
Redwood Cup • Jack & Jill + 1

Plus previews of the Midwinters season, ICSA Singlehanded Championship, LWSA Turkey Shoot, Melges 32 Gold Cup, ABYC Turkey Day Regatta, and more!

THE RACING



WWW.NORCALSAILING.COM



WWW.NORCALSAILING.COM



ERIK SIMONSON / WWW.PRESSURE-DROP.US



RYC's Great Pumpkin Regatta and party (clockwise from left): *The Express 27 'Get Happy!!' tries out a new mast configuration; Q: How does he see out of that mask? A: He doesn't; Trig Liljestrand's J/90 'Ragtime' in Saturday's brisk breeze; spinnaker flying was more challenging on Sunday; the social hour at Alcatraz; scary characters; the Phantom of the Regatta; it's a tradition to take kids along on Sunday; 'Libra' on Saturday; one-year-old Ronan Storesund raced on 'Tiki Blue'.*

Dorsey, 3 points; 2) **Wicked Sister**, Farr 36, Richard Courcier, 3; 3) **JetStream**, JS9000, Dan Alvarez, 6. (11 boats)

PHRF A — 1) **Encore**, Sydney 36CR, Wayne Koide, 2 points; 2) **California Condor**, Antrim Class 40, Buzz Blackett, 4; 3) **Deception**, SC50, Bill Helvestine, 6. (7 boats)

PHRF C — 1) **Stewball**, Express 37, Bob Harford, 2 points; 2) **Jarlen**, J/35, Bob Bloom, 5; 3) **Red Cloud**, Farr 36, Don Ahrens, 6. (7 boats)

PHRF G — 1) **Tartanic**, Tartan Ten, Robert Lanzafame, 5 points; 2) **Rio**, SC27, Tom Faraola, 8; 3) **Heart of Gold**, Olson 911S, Joan Byrne, 11. (4 boats)

PHRF J — 1) **Ahi**, Santana 35, Andy Newell, 4 points; 2) **First Light**, Beneteau 35s5, Alex Jefferies, 6; 3) **Sea Star**, Cal 39, Bob Walden, 9. (8 boats)

PHRF T — 1) **Siento el Viento**, C&C 29, Ian Matthew, 3 points; 2) **Brigadoon**, Black Watch 37, Robert Horton, 8; 3) **Critical Mass**, Mancebo 24, John Dukat, 9. (6 boats)

GREAT PUMPKIN PURSUIT, RYC, 10/26 (3r, 0t)
MONOHULL — 1) **Eight Ball**, Farr 30, Scott

Easom; 2) **Banditos**, Moore 24, John Kernot; 3) **Kwazy**, Wylie Wabbit, Colin Moore; 4) **Checked Past**, Wyliecat 39, Chris Gibbs; 5) **Wile E Coyote**, Express 27, Dan Pruzan. (143 boats)

MULTIHULL — 1) **Adrenaline**, D-Class cat, Bill Erkelens; 2) **Foxtrot**, F-24 MkII, Todd Craig; 3) **#413**, Hobie Miracle 20, Andrew Fletcher; 4) **Gradient Vee**, Marstrom 32, Randy Miller. (14 boats)

Full results at www.richmondyc.org

San Diego Lipton Cup

Day 1 of San Diego YC's 100th Sir Thomas Lipton Challenge Cup Regatta, sailed in chartered J/105s on Halloween, was the calm before the storm, and the advantage went to the Southern California teams in the shifty breeze.

On Saturday, November 1, steady winds on San Diego Bay averaged 12-14 knots, at times reaching up to 19 knots, allowing competitors to showcase their sailing skills in full winds. Perhaps it was that wind in the teens, a familiar velocity to San Francisco sailors, that bolstered the team from St. Francis YC. In Race 6,

StFYC stole a significant lead at the top mark. Chris Raab, Russ Silvestri, Steve Marsh, Mario Yovkov, Sean Svendsen, and Pascal Hines worked hard to keep their lead, finishing first and repeating with a consecutive first place in Race 7.

With beautiful conditions and fast sailing, the race committee was able to fit in a fifth race of the day, and StFYC's second-place finish pushed them above SDYC, the previous scoreboard leader.

On Sunday, StFYC kept their lead over the other 11 clubs to capture the Cup for the first time in 85 years. See www.sdyc.org/events/liptoncup.

— latitude/chris

Berkeley Yacht Club Midwinters

Berkeley YC kicked off their 2014-2015 midwinter series on November 8-9 on what's left of the Olympic Circle. "Due to a paucity of so-called permanent buoys on the Circle, BYC has joined the rest of the world and used brightly colored blow-up 'drop' buoys," reports BYC's Bobbi Tosse. "Last year, the pattern of the permanent buoys resembled a bowl, rather than a circle. Now all that's left is an arrow formed by GOC, XOC and COC, with the spinnaker-



ALL PHOTOS LATITUDE / CHRIS EXCEPT AS NOTED

eating basket of D forming the arrow's feather.

"Just for fun and also in response to a bunch of requests, an old-fashioned triangle course was available. (Anyone remember the old triangle/windward/leeward course? The gnarly reach-to-reach jibes at the wing mark? The fun broaches on a reaching leg when the spinnaker should probably have been left in its bag? The smarty-pants to leeward with his jib and no kite bringing you up, up, up until you broached? Ah, memories.)

"Saturday's event saw 50 starters in seven divisions. The wind was around 315° at 8-10 knots and stayed that way for most of the race.

"On Sunday, the wind had moved back to where it 'belonged' — from the Gate. Thirty-eight starters in five divisions came out, including two new divisions of 18 shorthanders. Windward/leeward courses for the fully crewed and triangle courses for the shorthanders were assigned. Then, just as the first boats were rounding the last mark, we were treated to the seemingly sudden appearance of thick fog, joined by 15-20 knots of breeze. The fog was so thick

that the finish buoy almost disappeared. Many racers were caught without comfy clothes and some with oversized front sails. I saw a lot of goose bumps on bare legs on the rails. This phenomenon lasted until the last boat finished. As the race committee boat proceeded back to Berkeley, the fair skies and light winds returned. Fascinating."

Six Cal 20s had their own division on Saturday. The BYC Midwinters are the first regatta in the fleet's 2015 Spinnaker Series (the Non-Spinnaker Series will start with the Corinthian Midwinters in January). John Fox on *Invader* took an early lead but slipped to third at the first windward mark rounding. "Howard Martin's *Recluse* nearly eclipsed us all on the last work-up to the finish," reports Richard vonEhrenkrook of *Can O'Whoopass*, "by taking starboard along the Berkeley Pier and getting the lee bow lift from the big new ebb. Jim Snow's *Raccoon* and the *Can* covered and retained their positions. *Can*, *'Coon* and *Recluse* finished in that order — within 30 seconds of each other."

Express 27s were the other one-design fleet, with 12 boats on Saturday and four on Sunday. Steve Katzman of

Dianne commented about Saturday's race: "A loud, bellowing tactician on another boat almost caused a collision at the first leeward mark. Avoiding that collision cost four boats passing us — better than a collision and subsequent insurance claims. We saw *Shenanigans* retrieving a crew on the run and still holding their place.

"On Sunday, the breeze filled in smartly on the run as we closed on *Levitation*. We didn't catch them, but then they gave up their second place with a non-douse. We slogged to the finish very overpowered to get a second behind *Motorcycle Irene*."

See www.berkeleyyc.org for more.

— latitude/chris

Sausalito Yacht Club Midwinter

After a short delay for wind, the first Sausalito YC Midwinter race started near Little Harding just as max ebb reached 3.5 knots. Larger boats sailed a short beat to a temporary mark at Yellow Bluff, followed by a long run against the ebb to YRA #8 and a long beat with the ebb back to the finish line. Smaller boats sailed a shorter two-lap course around temporaries at Yellow Bluff and Point Knox. Boats

THE RACING SHEET

MARTHA BLANCHFIELD / RENEGADE SAILING



ROXANNE FAIRBAIN / ROXSHOTS.SMUGMUG.COM



LATITUDE / CHRIS

Scenes from early-season midwinters, left to right: J/24s at RegattaPRO's Winter One Design on November 8; the CYC-based J/105 'She Loves It' in SYC's race on November 2; and the Moore 24s 'Twoirrational' and 'Hurricane' prepare to start BYC's Sunday series on November 9.

sailing both courses finished around the same time, making things interesting for the race committee.

The next SYC Midwinter is scheduled for December 7. Find info and standings at www.sausalitoyachtclub.org.

— pat broderick

Winter One Design

With 8-12 knots of wind out of the NNW, the RegattaPRO/SYC Winter One Design Series couldn't have started off with a better day than November 8. Two

races were run for six fleets.

All were very polite in their starts for the first race of the day. However, in the start of the second race, the J/70 and Moore 24 fleets had numerous boats aggressively working the line and incurring OCS calls. The J/105 fleet was especially aggressive and had two general recalls before getting started.

With 58 boats entered, there will be plenty of competition during the series. See www.regattapro.com for scores.

— Jeff Zarwell

U.S. Disabled Championship

In October's Racing Sheet, we introduced you to Team Alpha, a Sonar racing program run by the Bay Area Association of Disabled Sailors (BAADS). Two crews of BAADS Sonar sailors traveled to Texas to compete at the U.S. Disabled Championship hosted by Community Sailing Center Galveston on October 29-November 1. Dylan Young, John Wallace and Christopher Childers finished second. The other BAADS trio was comprised of Marinites Henrik Hartz, John Greener, and Larry Young. Find full results at www.ussailing.org.

— latitude/chris

No slight intended. The multihulls were inadvertently left out of last month's Inter Club Series results. Here they are:

INTER CLUB SERIES FINAL, 4/12-9/13 (6r, 1t)

MULTIHULL — 1) **Mojo**, F-25C, Christopher Harvey, 5 points; 2) **Peregrine Falcon**, F-27, Bill Gardner, 12; 3) **Ma's Rover**, F-31, Mark Eastham, 15. (5 boats)

Full results at www.jibeset.net

OKTOBERFEST, OYC, 10/4

PHRF < 150 — 1) **Tesa**, Catalina 42, Steve Haas; 2) **Spirit of Freedom**, J/124, Bill Mohr; 3) **Crinan II**, Wyliecat 30, Bill West. (4 boats)

PHRF 150-199 — 1) **Lelo Too**, Tartan 30, Emile Carles; 2) **Wings**, 5.5 Meter, Mike Jackson; 3) **Nice Turn**, Cal 2-29, Richard Johnson. (5 boats)

PHRF > 200 — 1) **El Guapo**, Santana 20, Joshua Butler; 2) **Take 5**, Wilderness 21, Steve Anders; 3) **Miss Kate**, Catalina 27, Michael Satterlund. (3 boats)

MERIT 25 — 1) **Double Agent**, Scott Ollivier; 2) **Meritage**, Jennifer Haas; 3) **Bandido**, George Gurrola. (3 boats)

NON-SPINNAKER — 1) **Infinity**, Columbia 26, Larry Bilsky; 2) **Simplicity**, Sabre 34, Tammy Mercado; 3) **Red Sky**, Beneteau First 36.7, Adam Their. (6 boats)

Full results at www.oaklandyachtclub.net

OKTOBERFEST PURSUIT RACE, BYC, 10/18

1) **Stewball**, Express 37, Bob Harford; 2) **GraviaX**, X-402, Gael Simon; 3) **Downtown Up-roar**, J/24, Darren Cumming; 4) **Feral Rooster**, J/24, Paul van Ravens. (15 boats)

Full results at www.berkeleyyc.org

THE BOX SCORES

YRA FALL CHAMPIONSHIP, BYC, 10/18

PHRF < 123 — 1) **Bodacious+**, 1D48, John Clauser, BYC; 2) **Pressure Drop**, Beneteau First 36.7, Carl Gish, StFYC; 3) **Centomiglia**, Flying Tiger 10, Mark Kennedy, RYC. (8 boats)

PHRF > 122 — 1) **Can O'Whoopass**, Cal 20, Richard vonEhrenkrook, SFYC; 2) **Byte Size**, Santana 22, Anna Alderkamp, TISC; 3) **Oreo**, Santana 22, Garth Copenhagen, SSS. (8 boats)

Full results at www.jibeset.net

OPEN 5.70 NORTH AMERICANS, SBYC, 10/18-19 (6r, 0t)

1) **The Rooster**, Joe Wells, 16 points; 2) **Petit Bateau**, Matt Siddens, 18; 3) **Frolic**, Marc Finot, 23. (10 boats)

Full results at www.southbeachyachtclub.org

MOORE 24 PCC, StFYC, 10/18-19 (5r, 0t)

1) **Moore Wave*Ohs**, Kurt Lahr, RYC, 8 points; 2) **Gruntled**, Bart Hackworth/Simon Winer, RYC, 14; 3) **Banditos**, John Kernot, RYC, 20; 4) **Ruby**, Stephen McCarthy, SSS, 27. (12 boats)

RUM RUNNER REGATTA, BALBOA YC/SDYC, 11/1

DIVISION 1 — 1) **Varuna**, Rogers 46, Chris Hermans; 2) **Bud**, TP52, Victor Wild; 3) **It's OK**, Andrews 49.9, Tom Purcell/Andy Rose. (7 boats)

DIVISION 2 — 1) **Mile High Klub**, Flying Tiger 10, Phillip Infelise; 2) **Timeshaver**, J/125, Viggo Torbensen; 3) **Horizon**, SC50, John Schulze. (7 boats)

DIVISION 3 — 1) **Blue Flash**, J/88, Scott Grealish; 2) **Briar Rose**, Bavaria 42, Les Linkogle; 3) **Schock N Awe**, Santana 35, Sal Ortiz. (4 boats)

MULTIHULL — 1) **Mighty Merloe**, ORMA 60,

HL Enloe. (1 boat)

Full results at www.sdy.org

RED ROCK REGATTA, TYC, 11/1

SPINNAKER — 1) **Hurricane Gulch**, C&C 33, Richard Selmeier; 2) **Siento el Viento**, C&C 29, Ian Matthew; 3) **Joyride**, J/105, Bill Hoehler. (4 boats)

NON-SPINNAKER — 1) **Lion**, Olson 25, Lon Woodrum/Steve Nimz; 2) **Red Hawk**, Hawkfarm, Shirley Vaughan; 3) **Cinnamon Girl**, Belley 26, Mariellen Stern. (7 boats)

Full results at www.tyc.org

JACK & JILL + 1, IYC, 11/2

SPINNAKER — 1) **Faster Faster!**, Merit 25, Suzanne Lee; 2) **Vitesse Too**, Hobie 33, Kristy Lugert; 3) **Meritage**, Merit 25, Jennifer Haas. (6 boats)

NON-SPINNAKER — 1) **Loco 2**, Mercury, Amy Cole; 2) **Bay Wind**, Catalina 30, Kim Lonie. (2 boats)

Full results at www.iyc.org

TURKEY SHOOT, LWSC, 11/8 (5r, 1t)

BANSHEE — 1) Charles Witcher, 5 points; 2) Craig Lee, 7; 3) Steve Galeria, 11. (7 boats)

DAYSAILER — 1) Dave Keran, 6 points; 2) Greg Miller, 8; 3) Steve Lowry, 10. (5 boats)

LASER — 1) David Wylie, 7 points; 2) Nick Cave, 7; 3) Steve Willett, 12. (7 boats)

THISTLE — 1) Michael Gillum, 12 points; 2) David Rumbaugh, 19; 3) Mike Arrow, 23. (5 boats)

LIDO 14 — 1) Pat Sayerhandley, 5 points; 2) Frank Chwalowski, 7; 3) Michael Pascual, 9. (3 boats)

OPEN CLASS — 1) AMF Force 5, David Potter, 9 points; 2) Catalina Expo 12.5, Jodelle Finnefrock, 10. (2 boats)

Full results at www.lwsailing.org



Out the Gate

deWitt

Time to Start Thinking of the Gift Giving Season.

We have several images of Jim's all ready to go out the door, either framed or unframed, for that special someone.

Visit www.jimdewitt.com or www.DeWittAmericasCupArt.com or simply call Pam deWitt to order!

P.S. Special orders take several weeks to produce, so call today!

DeWitt Art Gallery & Framing • (510) 236-1401 • pam@jimdewitt.com

Online Stores: www.jimdewitt.com • www.DeWittAmericasCupArt.com



1,000 Used Sails
Listed at
minneysyachtsurplus.com

**We Buy Good Used Sails
and Marine Equipment**

MINNEY'S YACHT SURPLUS

1500 Newport Bl., Costa Mesa, CA
949-548-4192 • minneys@aol.com

"We keep boating affordable!"

BEST COVERAGE

MARINE INSURANCE

More active cruising boats than any other marine agency in the Western Hemisphere.



BLUE WATER INSURANCE

CALL **(866) 463-0167**

or visit

www.bluewaterins.com

Get a Quote – It's Worth It!

BAY MARINE DIESEL

*Marine Inboard Diesel Repair
Surveys • Personalized Instruction*

Cummins | Ford/Lehman | Hino | Perkins
Universal | Westerbeke | Yanmar



Marty Chin, Owner – (510) 435-8870
Email: Baymarinediesel@comcast.net

WHITING & WEDLOCK

*Two Independent
Marine Surveyors
at
One Convenient
Location*

- Vessel surveys
- Consulting
- Deliveries



Serving the
Bay Area since 1980



www.norcalmarinesurveyors.com
(415) 505-3494

WORLD

*With reports on **Charter That Combine Racing and Pleasure Sailing**, plus ideas for **Christmas Gifts That Will Never Be Re-Gifted**.*

Variation on a Theme: The Case for Foreign Regatta Charters

To our way of thinking, a bareboat charter in some dreamy destination with a carefully selected group of family or friends is just about the best vacation option imaginable.

We especially enjoy chartering outside the US for a variety of reasons: being immersed in a different culture; sailing in warm trade winds; having access to clear, warm water for swimming and snorkeling; and being completely unplugged from telephones, email, and the buzz-killing nightly news. But there's another reason too. Whenever we sail overseas, we get a kick out of hanging out with local sailors, hearing their stories, and seeing how they run their boats. That's one reason we're big fans of foreign regatta charters. If you've never considered putting together a special group for a race charter in some far-flung destination, let us give you the pitch.

First, it's not so much about bringing home a trophy as it is about rubbing shoulders and swapping stories with an international mix of sailors, including the local hotshots. The goal should be to have the Walter Mitty-like experience of living like a laidback, barefoot islander for a few days; giving yourself a taste of what their seemingly idyllic lifestyle is all about.

With that in mind, you'll want to

Former sailing instructor Ron Brown did a race charter with students at Antigua Sailing Week, and had big fun racing in the trade winds.



RON BROWN

invite experienced sailors to be part of your team — at least some of whom have solid racing skills. But not the fanatical

regattas welcome bareboats, and most have bareboat-only classes: the biggest are the BVI Spring Regatta, the Heineken Regatta and Antigua Sailing Week. There are also a few prime opportunities in the



By special arrangement you can rent a spinnaker for your bareboat in Tahiti and the French West Indies, but it's rare elsewhere.

types who will spiral into a bottomless funk if they don't place high in the standings. You want the focused-but-fun sailors who'd have at least as much fun partying with the international competition after the race as they would squeaking past them at the finish line. Again, this is bareboat racing, not grand prix. Think of it as racing a rental car — no need to get too serious. Sure, out on the race course you'll give a 110% effort to place as high on the leaderboard as possible, but remember, you're racing a bareboat that probably isn't really rigged for racing, has no spinnaker or whisker pole, and may not have had its bottom cleaned for months. So no need to over-stress.

The prime place to sample bareboat racing, of course, is in the eastern Caribbean, where all the big

South Pacific: Tonga's Vava'u Regatta, French Polynesia's Tahiti Pearl Regatta, Hamilton Island Race Week in Australia's Whitsunday Islands and undoubtedly

2015 INTERNATIONAL REGATTAS THAT WELCOME BAREBOATS

- **St. Maarten Heineken Regatta**, March 6-8
011 (599) 544-2079 • www.heinekenregatta.com
- **St. Thomas (USVI) International Regatta**,
March 27-29 • (340) 775-6320 • www.rolexcupregatta.com
- **BVI Spring Regatta**, April 3-5
(284) 494-3286 • www.bvispringregatta.org
- **Antigua Sailing Week**, April 26-May 1
(268) 460-1799 • www.sailingweek.com
- **Tahiti Pearl Regatta**, April or May (TBA)
(689) 8779 5444 • www.tahitipearlregatta.org.pf
- **Hamilton Island Race Week**, August 15-22
61 2 8424 7400 • www.hamiltonislandraceweek.com.au/
- **Tonga's Vava'u Regatta**, late Sept (TBA)
regattavavau@gmail.com

several others in New Zealand.

You'll see the top-notch racing machines out on the course, but in your own division there'll be bareboats and cruisers that rate similarly to yours — in fact, some may be identical — so you'll always have opportunities for spirited, boat-for-boat action.

The best strategy is to arrive at least a few days — if not a week — before the regatta starts, so you and your crew will be totally familiar with how your boat handles and how all her gear works long before the first starting gun fires. And also so you can have some go-slow days when the focus is simply on relaxation and rejuvenation. Pre-regatta days will also give you a chance to explore ashore, swim, snorkel, hike. . . all the normal chartering activities. Then you'll top it all off with a three- to five-day regatta, complete with plenty of excitement out on the course, post-race barbecues, and

dancing under the stars to a live local band. Magic.

— andy

Why Not Give the Gift of Sailing?

Are you tired of giving Christmas presents that bring a ho-hum response? Why not give the gift of sailing instead?

The possibilities are vast: Give a non-sailing friend or family member a taste of the sport you love. Give your spouse, lover or sailing friends a refresher course. Or perhaps ask one of them to join you in a class you've been wanting to take for a long time, like marine weather or diesel engine maintenance.

In the Bay Area dozens of courses are offered every month that run the



Along the Turquoise Coast of Turkey, it's normal to lie stern-to a waterside village, and go ashore for a festive dinner complete with 'ouzo'.

gamut from sail handling skills, to maintenance, to preparation for long-haul cruising.

Listed below is a sampling of Bay Area sailing schools and clubs that offer a variety of classes, courses and seminars such as: Basic Keelboat Sailing, Basic

Are "Californians Dreaming?"

Stop dreaming – go sailing.

**CALL TO RESERVE AT OUR
BEST IN THE BVI PRICES!**



**Conch
Charters**

**www.conchcharters.com
(800) 521-8939**

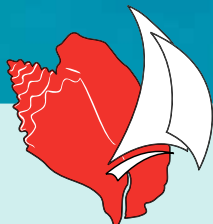

British Virgin Islands

Belize

The Grenadines



Our goal at TMM is simple - to ensure your sailing dreams come true. You will experience one-on-one personal service from our team who truly care about your charter experience with our company. For 35 years TMM has been providing its clients with first-hand local knowledge, friendly and memorable staff, and a diverse fleet of modern yachts at affordable prices.

Discover the TMM difference, you won't be disappointed.

**"Let us show you around
our backyard."**

Barney & Lin Crook
Owners of TMM for 32 years

**1-800-633-0155
www.sailtmm.com**



WORLD OF CHARTERING

Coastal Cruising, Bareboat Charter Vacation, Coastal Navigation, Motoring and Docking, Celestial Navigation, Cruising Catamaran, Basic Spinnaker Handling, Night Sailing, Private Lessons, Learn to Sail Your Boat, Marine Weather and Radar, Offshore Passagemaking, Diesel Maintenance and Repair, ASA certifications and US Coast Guard Licensing. We suggest you check out their websites or give them a call and see what upcoming classes pique your interest.

Or leave this article lying around, and maybe Santa will give the gift of sailing to you!

— lynn ringseis

- **Modern Sailing School & Club**, 2310 Marinship Way, Sausalito (415) 331-8250 or (800) 995-1668; www.modernsailing.com

- **Spinnaker Sailing** (of Redwood City), 451 Seaport Ct., Redwood City



"Look Ma, I'm sailing!" Of all the gifts you might give this season, there's one that's not likely to be to be re-gifted: The gift of sailing, of course.

(650) 363-1390; www.spinnakersailing.com

- **Spinnaker Sailing** (of San Francisco), Pier 40, San Francisco (415) 543-7333; www.spinnaker-sailing.com

- **Tradewinds Sailing School and Club**, 2580 Spinnaker Way, Richmond (510) 232-7999 or (800) 321-TWSC; www.tradewindssailing.com

- **OCSC Sailing**, One Spinnaker Way,

Berkeley Marina, Berkeley (510) 843-4200 or (800) 223-2984; www.ocscsailing.com

- **Afterguard Sailing Academy**, 1853 Embarcadero #2b, Oakland (510) 535-1954; www.afterguard.net

- **Club Nautique**, two locations: 1150 Ballena Blvd., Suite 161, Alameda (510) 865-4700; 400 Harbor Drive, Suite D, Sausalito (415) 332-8001; www.clubnautique.net

- **J World Performance Sailing**, 423 Water Street, Oakland (510) 271-4780 www.sailing-jworld.com

- **Sail Berkeley**, 201 University Ave., J-Dock, Berkeley (510) 343-5635 www.sailberkeley.com

- **Sailing Education Adventures**, 3001 Bridgeway #199, Sausalito (415) 775-8779 www.sailingeducationadventures.org

- **Treasure Island Sailing Center**, 698 California Ave., #112, San Francisco (415) 421-2225 www.tisailing.org

McDERMOTT COSTA

insurance brokers - est. 1938

Commercial Operations

- COMMERCIAL POLICIES
Marinas, Yards, Yacht Clubs, Brokers, Shipwrights

Recreational Inshore/Offshore

- YACHT & BOAT POLICIES
Offshore, Coastal, Inland and Liveaboards



BILL FOWLER – Marine Specialist
McDERMOTT COSTA INSURANCE
(510) 957-2012 Fax (510) 357-3230
bfowler@mcdermottcosta.com



BVI YACHT CHARTERS

Call: +1 888 615 4006
Or: +1 284 494 4289

BVI Yacht Charters is the first port of call for all yacht charters in the BVI and St Martin. Whether you are looking for a Catamaran or a Monohull, a week or just a few days, our professional team is on hand to make it work, your way.

BVI YACHT CHARTERS

** 10% off all new bookings when you mention this ad.

www.bviyc.com

charters@bviyc.com

Bilge Steam Cleaning Oil Changes

Professional service at your slip!!!



MarineLube 877 744-2244
www.MarineLube.biz

VISA MasterCard American Express Discover

Fuel Polishing Tank Cleaning



MAKELA BOATWORKS
Family owned since 1948

Wooden Boat Building • Repair and Restoration

19280 South Harbor Drive • Fort Bragg, CA 95437
(707) 964-3963
email: howard@makelaboatworks.com • www.Makelaboatworks.com



Save Your Aft!

Using one of our 1900+ patterns or your own pattern, let our craftsmen create a comfortable, durable, and stylish set of all-weather cushions for your cockpit. Find your custom, closed cell foam cushions at www.bottomsiders.com!

BottomSiders

Call Toll Free: (800) 438-0633
cushions@bottomsiders.com
Fax: 360-533-4474

BottomSiders
2305 Bay Avenue
Hoquiam, WA 98550

KATADYN SURVIVOR 35 WATERMAKER

The Survivor is a must for all sea-going vessels and is the most widely used emergency desalinator. It is used by the U.S. and international forces. It is able to produce 4.5 liters of drinkable water per hour.

Reconditioned by Katadyn **\$1050**

Also available:
New Katadyn Survivor 35: \$2195
New Katadyn Survivor 40-E: \$3695
New Katadyn Survivor 80-E: \$4695



EQUIPMENT PARTS SALES
In the U.S.: (800) 417-2279 • Outside the U.S.: (717) 896-9110
email: rod@equipmentpartssales.com

“Have you started your holiday shopping yet? Mine’s done!” says Crissy Fields.

Give the gift of **Latitude 38** Logowear



PLACE YOUR ORDER BY DECEMBER 10 FOR DELIVERY IN TIME FOR CHRISTMAS

See our current selection and order online at:
www.latitude38.com

Or order by mail: Latitude 38, attn: Logowear
15 Locust Ave., Mill Valley, CA 94941

CHANGES

With reports from **Swell** on what Liz Clark has been up to in French Polynesia; from **Geja** on a seventh summer in the Med; from **Irie** on the suitability of small cats for cruising in the Caribbean and the South Pacific; from post -Odile **Cabo San Lucas**; and **Cruise Notes**.

Swell — Cal 40

Liz Clark

Positive Vibrations From Polynesia (Santa Barbara)

I just wanted to check in and say 'Hi' from French Polynesia. It's been another busy but wonderful year for me.

Being one of ten nominees for *National Geographic's* Adventurer of the Year came as a complete surprise to me! I'm so honored. The voting goes on until January 31, and I wouldn't mind if *Latitude* readers went to my website or *National Geographic's* and voted for me. As they say in politics, vote early and vote often. Ha, ha, ha.

Liz seemed and was so young — just 25 — when we took this photo of her in Santa Barbara prior to the start of her adventure in 2005.

I got back to *Swell* in June, then made a 900-mile round trip to the Tuamotus to meet up with a crew from Patagonia, one of my sponsors. It was rough for the first two days because of a westerly front that came through, and I got really seasick. I should have waited 12 hours, because I got wind too much on the nose as well as a miserable sea resulting from the clash of swells from the north and south. Luckily I had a friend with me to help with the watches and laugh when I puked. But it was great to get *Swell* out to sea again and into some wild corners.

Patagonia was putting on a 'Wom-Clark has seen beautiful times in French Polynesia such as this, but there have also been rough passages and months in the boatyard.

en's Trip', the goal of which was to bring their main female ambassadors together in a place where we could all do what we do best. The other two women, Kimi Werner and Lea Brassy, were really incredible.

Kimi is a champion spear fisher and ocean conservationist. She has the sweetest and most humble soul, and it was magical to watch her underwater. She kills with respect, choosing the most ecologically sound prey. Her mission is to get people to reconnect with their food.

Lea is an adventurer, surfer, spear fisher — and all-around bad ass! She does radical missions, such as trekking through the snow to get to remote surf spots in Iceland and Northern Europe. The three of us enjoyed learning from one another and got on like wildfire.

I'm back in the Societies now, working on a book project with Patagonia and a web series with my girlfriend Leah, and am about to relaunch my website. Between the nonstop swell and everything else, my plate has been fabulously full. I've been hangin' on the hook in the lagoon enjoying tubes, coconuts, rainbows, good friends, fruit — and shirtless, sexy brown men paddling by on canoes. There is no cabin boy for the moment, but there are always a few sharks circling. Ha, ha, ha.

Swell is in great shape, as her hull and rig have been repaired since I was t-boned by a charter cat. She looks lovely with her newly painted hull and decks. New canvas, too. My sails are in pretty sad shape, but I'm not facing any major boat problems at the moment.

It's good that *Swell* is in fine shape because most of the surf here in Polynesia is at reef passes, so you need a boat to get to them — unless you want to paddle all the way across a lagoon. There are also lots of outer-island spots that are only accessible by boat because either planes don't fly to the islands or if they do, they're too small to carry boards. With the Teahupoo surf spot becoming world-



famous over the last five years or so, surfing in French Polynesia has become much more popular.

People always ask how I've recovered from breaking my neck while bodysurfing in San Diego. My neck is fine, although I get a little stiffness if I surf a lot without stretching or getting a massage. I attribute my recovery to yoga and my plant-based diet.

I swear that my diet has made an incredible difference in my levels of energy, overall strength, immunity — and even my complexion. I feel as healthy as I did 10 years ago. Plus my plant-based diet is really in line with my eco/spiritual values, so it feels just right. Every now and then I do eat a little fish, but only if I can find a smaller fish from a plentiful species. And like Kimi, I kill the fish I'm

LATTUDE/RICHARD



COURTESY SWELL





The Life of Liz in the South Pacific. Spread; Curling up with her adopted, formerly homeless cat Amelia on the bottom of her inflatable on the bow of 'Swell'. Upper left; Exiting a lovely Polynesian tube. Right; Looking photogenic as a National Geographic nominee for Adventurer of the Year.

going to eat with respect.

I almost forgot, I got a kitty that I named Amelia, aka Tropicat. She was abandoned, so I decided to try to find her a home. Before long she had found a home in my heart. We're terribly alike. She goes everywhere with me, which is hilarious.

I'm in no particular hurry to move on, and I'll be here until the Patagonia book deadline in May. After that, I might head to the Marshall Islands in the North Pacific, then down to Fiji, Tonga and New Zealand.

All in all, life is damn good! Positive vibrations, light and love to everyone.

— liz 10/15/2014

**Geja — 1976 Islander 36
Andrew Vik
A Wet and Stormy Med
(San Francisco)**

For the seventh straight summer, my salty old Islander 36 *Geja* and I, both hailing from San Francisco, enjoyed an exciting voyage in the Med. Croatia's Dalmatian Coast had been an excellent foreign home to *Geja* for the previous five summers, so I'd already covered much of the Adriatic Sea at least twice. The one region that I'd only visited once was the far northern Adriatic, so this year it was Venice or bust.

From *Geja's* winter home of Trogir, it's 220 miles in a straight

northwest line to Venice. Viewed another way, it's four weeks of casual daysailing up the former Yugoslavian coast. I chose the latter, of course, as the Croatian ar-

The imposing fort at Trogir, Croatia, a UNESCO World Heritage Site. Trogir has been the winter home for Vik's Islander 36 for years.



CHANGES

chipelago is dotted with quaint villages, countless anchorages, and several really hot Mediterranean party spots.

As usual, my crew consisted of friends and acquaintances from the U.S. and northern Europe. Typically,



GEJA

Vilja of Finland, part of the international crew.

two to three crew stay for a week at a time, and I make sure to end each leg in some inhabited location with a nearby airport. This makes for a pretty rigid schedule, but it's worked well over the years. Starting in mid-July, the first of seven weeks went smoothly — despite one nasty little weather system that blew through while we were in the party town of Vodice. *Geja* was secure in the government-run ACI marina when a nasty storm cell hit at 5 a.m., which was not long after my two crewmates and I had turned in after a late night out. I suspect that a lightning strike hitting *Geja* would have really screwed up my summer plans, but we escaped unscathed — and with a freshly rinsed boat. This storm was to be the first of many to pass through during what proved to be an unusually cool and wet summer in the Med.

The storm threat remained for several days, but my crew and I managed to get in some great sailing anyway. We kept the mainsail reefed most of the time as we beat our way up the coast through the Kornati Islands to Zadar, one of Croatia's main coastal towns.

Geja got to chill out in Marina Zadar for two nights — at 70 euros/night — while swapping crew. Staying multiple nights in a place during crew changes

In order to keep up with the grooming standards of young Italian males on the hunt, Vik had to submit to a painful 15-euro 'manscaping'.



GEJA

gives me ample time to clean house, do a big grocery run, fill the water tanks, and complete other tasks.

The swap-over period also allowed me to have my chest waxed — 'manscaping' — for the first time. It's not that anyone would call my blonde chest hair excessive, but the male 'kids' at the beach parties — particularly the Italians — are so well-groomed that I felt compelled. With my two female crew along for moral support — and for their own entertainment — I found a spot in town where I could have my hair ripped out for just 15 euros. The pain was tolerable and the results smooth.

Week two began nicely with typically glorious weather and pleasant sailing. The first stop after Zadar was the adorable town of Bozava on the island of Dugi Otok. Med-moored to the quay, we were approached by a non-English-speaking senior citizen who somehow conveyed to us that he had some homegrown tomatoes for sale. My crewmate and I ventured up a path to his home, where the dude had not only veggies, but also a cool cellar with huge wooden barrels full of wine from his vineyard. We did not leave empty-handed.

Later in the week, we awoke early to building seas and cloudy skies in the poorly protected anchorage at Silba. We got out of there fast, getting an early start on the 14-mile crossing to the island of Pag. Though it poured on the way, the winds remained from aft for an easy crossing. Pag is host to Zrce, Croatia's most notorious Ibiza-style party place, intentionally located on a remote beach several kilometers from any town. Zrce usually goes off in the high season with its many daytime beach parties. But it was eerily mellow because of the funky weather, and too cold for me to show off my freshly waxed chest.

A couple of days later along the mainland, at the foot of the Velebit mountain range, we spent a night in Zavratica, a fjord-like cove with a submerged World War II wreck. By day it's full of tourists, but we had the place to ourselves for a most memorable night. It turned out to be a spooky spot, with animals rustling around in the darkness and not a single light or other sign of human existence in sight.

This part of Croatia has some really dramatic scenery. The islands of Pag, Rab, and Krk all face the notorious Velebit Mountains. In the winter, the *bora*, a



crazy offshore wind, blows down from the mountains — at times at speeds of over 100 knots! As a result, most vegetation has been stripped from the islands' east-facing hills, yielding a dramatically stark landscape. The town of Baska on Krk has exactly this backdrop.

With another crew swap in Baska, we started the third week with an uneventful motorsail from Baska to Krk Town. It being a Saturday, and with my first male crewmate aboard, we were up for hitting the town. But of course a massive rainstorm blasted through late in the evening, threatening to dampen the fun. What was that, storm number three? We nonetheless managed a decent night out once the rain let up.

Sailing onward into the lake-like Gulf of Kvarner, we came across a small powerboat waving an oar. As we approached, I yelled out, "U.S. Navy at your service!" The guy and girl had engine problems, so we gave them a 20-minute tow to shore.

IN LATITUDES

ALL PHOTOS COURTESY ANDREW VIK



People and places from 'Geja's seventh season in the Med. Clockwise from lower right. Vilja, a fit Finn. Majestic Rab, Croatia. One of the flab-free crew starts to detox after a big night. Looking down at Vurlje in Kornati National Park. The young and the very restless. Vik, looking lost, in the rain at Krk. A great villa at Opatija, Croatia. Andrew Vik. Amazing Rovinj, Croatia. Mari, a well-dressed helmswoman. Another view of Kornati National Park in Croatia.

In the coming days, this local Croatian couple repaid the favor many times over, showing us around and driving me to several nautical shops in search of a new starter battery and other items. I was even invited to eat dinner at the girl's family home, where nearly all the food and wine on the table had been grown or produced at their family farm.

Far in the north of Croatia is the town of Opatija, where we took a berth at the fancy Hotel Admiral. Modern-day Opatija was established as a seaside resort by the Austrians in the late 1800s. The many villas, luxury hotels, and gardens are grand and beautiful, and much different from the architecture found elsewhere in Croatia. It wasn't a bad place to be stuck for two nights as storm number four barreled through, threatening to drop several inches of rain.

Week three wrapped up in Pula, which is near the southern tip of the Istrian peninsula. The port is a half-abandoned dump, but the town boasts an incredible 2,000-year-old amphitheater, much like the one in Rome. *Geja's* marina berth was just a few hundred yards from the amphitheater. Had we stayed there through Saturday evening, we would have heard British rockers Status Quo perform.

While paying up in the marina office to get going with Week four, I came across a Swedish charterer who had lost all his electronics and refrigerator to a lightning strike. The chipper fellow was pretty relaxed about it, continuing his three-week family holiday with the

technologically crippled boat (and, gasp, warm beer).

My crew that week included Rob and Christine Aronen, the only couple allowed to join *Geja*. I'd met them during the 2006 Ha-Ha as they skippered their boat *Nomad* from San Francisco to Mexico. Their sailing, shopping and

Islander 36s have been one of the classic San Francisco Bay designs since the mid-1970s. Few have cruised as far or as much as 'Geja'.



GEJA

CHANGES

cooking skills allowed me to spend more time relaxing. Otherwise *Geja's* summer voyages are marathons, as each week's crew wants to see and do as much as possible. Not relaxing, but it's super fun.

Rovinj, 20 miles up the Istrian peninsula, ranks among Croatia's loveliest towns. And there in the north, in what had been Italy until the end of World War II, the classic Croatian limestone buildings start to take on various pastel hues. Rovinj's multistory residences climb right from the waterline, laundry on lines flailing in the wind above the sea.

After two nights in Rovinj, I was paying the tab in the marina office when, out of nowhere, an intense boom stunned everyone in the marina. It was a lightning strike right overhead, but without rain or wind as a warning. The office girls screamed and dove under their desks as though it were an earthquake. Two of my crew, who had been standing on deck at the time, darted ashore. As folks settled down, my crew and I returned to *Geja* to batten down the hatches just before the rain hit. For two hours we sat in the saloon as rain, wind, lightning and thunder surrounded us. That was storm number five.

After the prolonged storm blew through, we had a great close reach up to Porec, where we spent two nights moored to the quay, including for my birthday. And a bustling quay it was! The hippest lounge in town was a stone's throw from *Geja*, so we enjoyed both superb people-watching and great music. It was a far better spot than any hotel could provide — except when the garbage trucks and street sweepers did their thing at sunrise. The Croatians like to keep things tidy.

In Porec, on our way by taxi to the

Two of Croatia's many spectacular sites: The top is the imposing coliseum at Pula. On the bottom is the lovely harbor at Ravinj.

Saints & Sinners Beach for the afternoon, I almost got the entire crew to get matching henna 'tramp stamps'. It was, after all, my birthday and my wish. Next year, guys, next year. Instead, the crew surprised me that evening with a round of Aperol Spritz, which a waiter delivered right into *Geja's* cockpit. The crew spoiled me well on my special day.

Although Croatia has been in the European Union since 2013, it is not yet in the Schengen Zone. So boats still have to check out when crossing into a European country, which we did when exiting for Slovenia. Once checked into Slovenia, however, we were free to sail on to Italy with no fuss, which we did after just one night in beautiful Piran, Slovenia.

Our next stop? The Venice Lagoon. More next month.

— andrew 11/13/2014

Irie — Tobago 35 Cat Mark Kilty & Liesbet Colleart Seven Years Cruising a Small Cat (Ex-Bay Area)

Many monohull sailors wonder if a cat as small as our F/P Tobago 35 is big enough to safely and enjoyably cruise the South Pacific. I'm happy to share our experiences and impressions.

Latitude readers with good memories may recall that in 2006 Mark and I took off cruising from San Francisco aboard our Islander Freeport 36 with Kali and Darwin, our two Australian shepherds. By the time we got to Santa Cruz, just 75 miles into our cruise, it was clear that our dogs hated the heeling and were miserable with the motion of a monohull. I didn't feel so good myself. So we abandoned our cruising dream right then.

After a year of land travel in Central America, we decided to give cruising another try, thinking that doing it on a more stable catamaran might be much easier on the dogs — and me. To that end we purchased *Irie*, our small catamaran, in Annapolis.

We took off cruising again in 2007. We'd never sailed a cat before, but our assumptions proved to be correct — as cruising on our admittedly small cat



was blissful compared to doing it on a similar-sized monohull.

Over the span of a year, we leisurely sailed *Irie* to the Eastern Caribbean, where we decided to spend three years. We cruised between St. Maarten/St. Martin, which was our work base during the cruising season, and Grenada, where we explored and worked during the hurricane season.

After three years, we made our way west to the uniquely beautiful San Blas Islands of Panama, where we enjoyed living in a paradisiacal part of the Caribbean for a year. *Irie's* 35-ft length and 19-ft beam were perfect for the two of us and our two dogs. *Irie's* shallow 3-foot draft allowed us to savor reef anchorages and bays not deep enough for monohulls — as had previously also been the case in the Bahamas, BVIs and Grenadines.

The Caribbean is well-known for consistent winds, and we'd found that *Irie* was well suited for them. Even upwind passages weren't a big deal. Carefully monitoring the weather prevented us from getting caught in anything really nasty. There is an active social/party scene in the Caribbean, and *Irie's* large cockpit came in very handy for that.

GEJA





bit too uncomfortable for our liking, as the anchorages were quite crowded — there are more boats in the Pacific than you might think! — and our light multihull didn't always move in concert with the monohulls. And even though we had a catamaran, many of the bays had a constant swell that made the anchorages rolly.

That said, the Gambiers, the Tuamotus and the Society Islands proved to be a great cruising ground for our small cat, and we can't wait to explore more. The bottom line is that we think our small cat has been a great cruising boat for the seven years that this freelance writer from Belgium, and her American husband, have been cruising from the East Coast to the Caribbean to French Polynesia.

A photo sure to inspire the cruising dreams of many a sailor — little 'Irie' anchored off one of the 365 San Blas Islands of Panama.

Without giving much thought to the fact that our cat is much smaller than most in the South Pacific, in 2013 Mark and I transited the Panama Canal and switched oceans. By this time both of our dogs had passed on.

Although the Pacific Ocean is huge, the name means 'peaceful ocean', so how uncomfortable could it be? Perhaps it was because of the course we would take to the Gambier Islands — to avoid crowds — but our days of easy Caribbean sailing were over. We were initially deceived by a comfortable and enjoyable one-week passage from Panama to the Galapagos Islands, which many sailors said was going to be the roughest of all. So when we dove down on our next leg, the 3,000-miler to the Gambiers, we expected the same easy sailing with relaxing watches. Wrong!

We were to learn the hard way that weather forecasts for the Pacific are unreliable, even when making short passages. But ours was anything but a short trip, and the seas were typically confused and much bigger than we'd been used to

in the Atlantic.

On Day 10 of what would be our 21-day passage to the Gambiers — which required sailing harder on the wind than if we'd sailed to the Marquesas — we had very windy conditions. And the winds were on the beam, which is the worst.

When the wind blows 30-35 knots for days on end, which it did, the swells build to 15 feet and you need to reef deeply. While 180-mile days on a little 35-ft cat sound impressive, they were not comfortable miles. We often had saltwater crashing over the hull and into the cockpit, but we never felt unsafe. Ours was one of the few boats to make the crossing without ripped sails, failed rigging, or a lost rudder.

Once we got to French Polynesia, however, our little cat really came into her element. The sailing trips between the archipelagos and the islands have been uneventful and relatively benign, and the cat is perfect for shallow reef anchorages, which are our favorites.

The Marquesas were still a

It may be folly, but I'm going to attempt to quantify our cat's qualities on a scale of 1 to 10:

Amount of Living Space — 9. *Irie* is perfect for two adults and two dogs, plus two visitors for up to two weeks.

Comfort in Anchorages — 8. A bigger

Mark and Liesbet above the transom steps of 'Irie', with a nautical friend on the bottom. They've cruised the little cat for seven years.

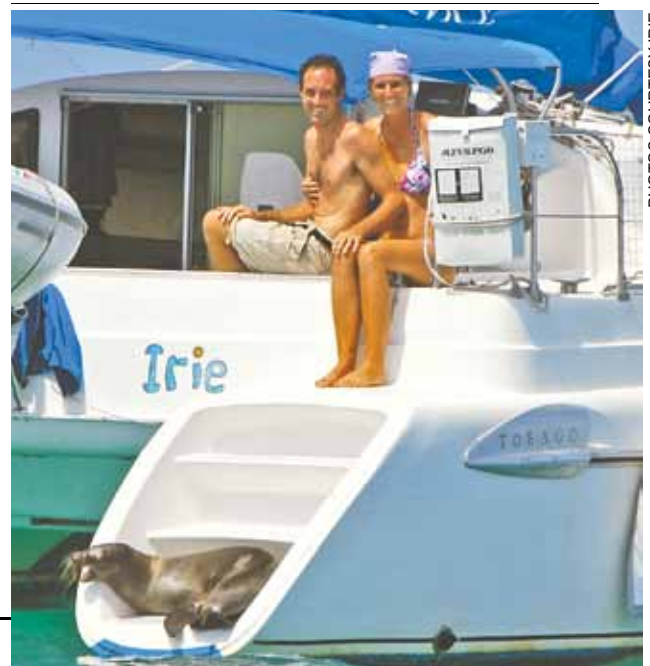

PHOTOS COURTESY IRIE

CHANGES

cat would be more stable and thus more comfortable.

Overall Sailing Performance — 9.

Sailing Performance to Weather — 7.

As with all cruising cats, this is *Irie's* weakest point of sail.

Storage Space — 9. *Irie* has all the room we need, but this can be deceiving, as we don't have a lot of junk. If we don't use something for a year, we sell it, trade it, or give it away.

Comfort in Rough Weather — 3. No boat is comfortable in rough weather, but a bigger cat

would be more so.

Motoring Speed — 7. We have two small diesels.

Fuel Economy — 8. With both engines running at 2,200 rpm, we burn 3/4 of a gallon an hour.

Dinghy Launch and Retrieval — 9. Only an electric winch would make it easier.

Confidence in Boat — 9.

The two drawbacks I see of having a very small cat are: 1) Discomfort in big seas when the wind is forward of the beam, and 2) The small size of the jib.

While we would love to have a larger cat, *Irie* was what we could afford, and she's been an excellent long distance cruiser. Unfortunately, we've had some health issues, so while we continue to cruise her, we've also put her up for sale. If anyone is interested, they can visit catamaran-irie-for-sale.html.

— *liesbet* 11/10/2014

The two most obvious signs that *Odile* hit Cabo are the McDonald's in shambles and 35% of the main marina's slips being destroyed.

Post *Odile* Cabo San Lucas Baja California Sur

The Wanderer's program has always been to leave Cabo as soon as possible after the end of the Ha-Ha. "Two days of Cabo a year is great, three is too much" has been our mantra about the tourist town. This year, thanks to a persistent low — about the only one between Conception and Tehuantepec, and the likes of which we haven't seen on these dates between Cabo and P.V. in 21 years — it didn't make sense to leave on Sunday morning. Or Monday. Or Tuesday. Wednesday might have worked, but as we would have to labor on computer for some of the 285-mile trip to P.V., we opted to have another day at the 'office' at the Baja Cantina. Our extra time in Cabo enabled us to catch up with the local news.

The best news about Cabo is that, unlike right after hurricane *Odile* made a direct hit on September 14, it doesn't look bad at all. Other than one-third of the docks in the marina being knocked out, and the McDonald's still in shambles, it's hard to tell a hurricane hit at all. That does not, however, mean that all the big resorts have reopened or that you can't find evidence of the Category 3 storm if you want to look for it.

There were five main reasons that things were so bad in Cabo right after *Odile* hit: 1) Having been swiped or hit by numerous weaker hurricanes before, nobody took *Odile* too seriously, especially since it didn't turn toward Cabo until shortly before it hit. So nobody was prepared. 2) Instead of being on the scene to exercise leadership, the mayor of Cabo was out of town at a boxing match in Vegas. The local government and police have been castigated for doing nothing. 3) All the workers, who live hand-to-mouth, had been paid the day before the hurricane. But since they get all their money from ATMs, and the ATMs didn't work because the electricity was

out, they didn't have access to their money to buy food and water for their families. So when one big store decided to give away the food that would spoil anyway, it let the floodgates open. All the major stores were soon looted of ev-



The F/P 35 'Irie' anchored off the lush vegetation of the Marquesas.

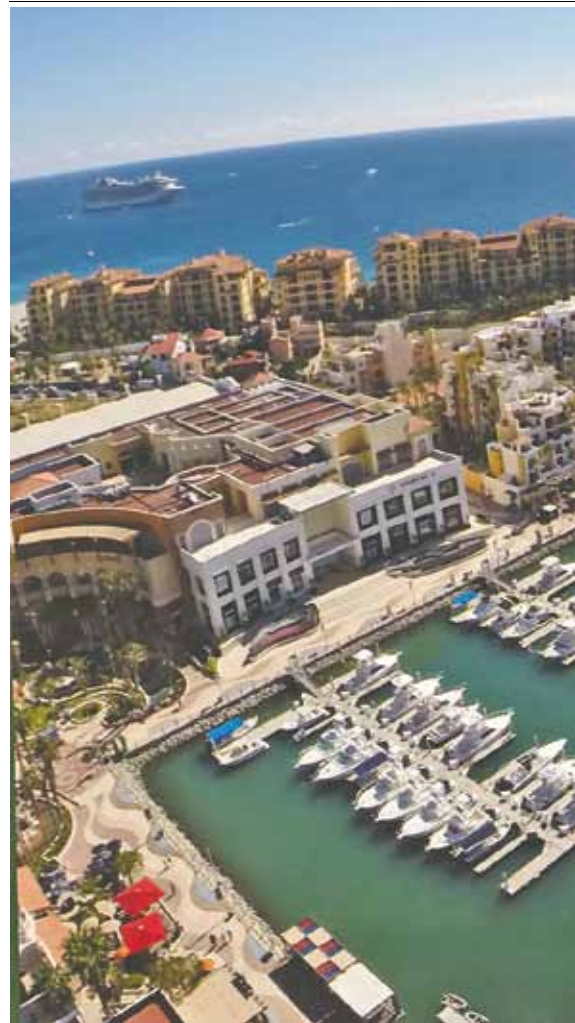

everything. "I saw people with Hummers loading flat screen televisions on their cars," said one disgruntled local who shall remain unnamed.

4) Most of the local military detachment was in Mexico City to march in the Independence Day parade. "When they finally got back, they hadn't slept in three days and were exhausted," said one. 5) Cabo's only radio station lost its tower, so nobody knew what was going on for more than three days.

Cabo was indeed dangerous, with some of our Mexican friends running regular patrols around their property and firing weapons to drive off marauders who had breached their fences. A Mexican woman we often work with told us that it was so dangerous that Mexican embassy officials tried to insist that she and her American husband fly out on a special plane. They declined because they had business interests, but the woman armed herself with a machete while at her home and admits to having been frightened for her personal safety.

Once the troops returned, augmented



LATITUDE AERIAL

IN LATITUDES



LATITUDE AERIAL

This 'Latitude' quadcopter photo of Cabo San Lucas shows the bay, Land's End, the Pacific, and the IGY Marina. Other than the H and I docks of the marina — far middle right — it looks as beautiful as ever. And in a stroke of good fortune, the port captain has effectively cut way back on jet skis.

by a very professional detachment normally assigned to protect visiting dignitaries, order was restored. The chaos is now history. Cabo looks good, and what it needs now is customers so everybody can go back to work. Recognized as the Grand Poobah of the Ha-Ha, the Wanderer was repeatedly thanked, even by business owners we'd never met before, for bringing more than 500 much-needed visitors to the local economy.

Still stuck in Cabo on Tuesday night, we accepted a dinner invitation at the Cabo home of ship's agent Victor Berrara, where he lives with his lovely wife Alejandra and two young children. Although only in their early 30s, the couple have been together for something like 17 years already. Victor's father, deceased for seven years, had been a ship's agent in Cabo starting in the 1970s. Victor started learning the trade as a teenager, and is now one of three ship's agents in town. He and Alejandra have other busi-

nesses, too: a coffee shop, a hookah bar, and a small hotel in the Pedregal.

Victor explained that the port captain in Cabo is new — and has the nobility of character not to accept bribes. Among port captains of the world, that's not always the case. The port captain has decreed that jet skis can no longer be rented off the beach, and have to be staged offshore. This has greatly reduced jet ski activity, which has been the great bane of owners of anchored boats, swimmers, and SUP'ers.

When we asked Victor what the deal was with the port captain in La Paz saying boats needed a medical clearance/certificate to leave the country, he said it was indeed a law on the books, but one that nobody seems to follow except the officials in La Paz. In Cabo you just need to fill out a form.

Mexico, of course, is the home of officials who interpret laws in different and sometimes curious ways. "For example," said Victor, "the port captain in Cabo requires more paperwork and

documents from boats leaving Cabo for the States than boats arriving in Cabo from the States." You'd think it would be the opposite.

When it comes to TIPs (Temporary Import Permits), Victor says it makes no difference if you have one of the old 20-year ones, an 'old' new one from online or from Banjercito more than a few months back, or a 'new' new one from Banjercito. They are all good. Victor has a two-year-old 'old' new TIP for the Bayliner he and his family take to La Paz for visits to the nearby islands.

What's the difference between the 'old' new TIPs and the 'new' new TIPs you get from Banjercito? "The 'new' new ones don't require that you fill out a detailed list of all the equipment you have on your boat," says Victor. "They don't seem to care about that anymore." And to think of all the headaches boatowners got trying to figure out how to fill out the equipment list properly, something the software wouldn't allow. That said, if anyone hasn't gotten a TIP within the past year or two, we'd get a 'new' new one from Banjercito. They are cheap enough.

Other tidbits from Victor: 1) Certain local interests wanted — and almost succeeded in getting — permission to build a cruise-ship dock from the southeast breakwater out into the bay! Victor thinks they will be successful with their efforts in less than 10 years. Even though the dock couldn't go far into the bay because the water is so deep, we hope he's wrong. 2) Homes, condos and property continue to sell quite well in Cabo. And finally, 3) Victor and his family hope to do a circumnavigation some day.

One of the fun sights in the Cabo Marina was watching the owner of the Nordhavn 73 *Tortuga*, which is a much larger boat than her length would suggest, lift

Hurricane Odile left world-famous Lover's Beach, the venue for several 'Sports Illustrated' swimsuit photo shoots, greatly diminished.



LATITUDE AERIAL

CHANGES

a small Fiat automobile from the forward hold and unload it onto the dock for local use. This was followed by a motor scooter. The loquacious owner, who lives in Newport and Vegas, and who usually operates the large boat without paid

crew except for Capt Jack, his little dog, spotted de Mallorca walking down the docks with a St. Barth backpack. "Hey, my wife and I got married there," he told her. "We'll be there in a couple of weeks." His wife, it turns out, is a very, very heavy hitter in the world of U.S. retailing.

Surf from Odile broke over the famed arch, which managed to survive.

Tortuga didn't seem like a vessel that could be bought and maintained on an airline pilot's salary.

Cabo isn't normally our kind of town, but with so few people around — and after the Ha-Ha the smallest number of boats we've ever seen in the marina — we actually enjoyed the few hours we got each day away from banging on the keyboard. Cabo's south-facing beach — the one out by the Sol Mar, Playa Grande, Finisterre and other hotels on the Pacific side — is truly one of the great beaches in the world. Unless you're staying in one of the hotels or condo complexes, there is no real access, which is why there are no vendors on that beach. Fortunately, we had a friend staying in the Playa Grande for a couple of days, and used his room number to get in to use the pool and order drinks. It worked so well that we continued to do it for several days

The bottom contour of the beach on Cabo's Pacific side is conducive to unusually large and dangerous waves.

after he left. Look like you belong there, behave yourself, order a few drinks, and nobody seems to mind. The cloud formations and sunsets as viewed from that beach are quite spectacular.

As beautiful as the beach and the clear blue water are, it's quite dangerous for all but the most skilled watermen or waterwomen to go in. The bottom comes up very quickly, so the waves break with tremendous force, Pipeline-style, in just a few inches of water. They have snapped necks. Equally bad, it's almost impossible to stand up against the force of the water that rapidly recedes into the next incoming wave. In these conditions, it's entirely possible to drown within a few feet of the sand. Almost every day is a red-flag day. A lesser problem is the fine sand, which gets into one's hair and orifices unlike anywhere else in the world. Your pillow is likely to be sprinkled with sand the morning after a bodysurfing session.

As we said, Cabo is not our favorite place in Mexico, but there are tens of thousands of really good, honest, hard-working people there who have taken a big hit. Many live hand-to-mouth trying to support their families, but have lost their homes, which in many cases consisted of little more than boxes, plastic tarps and bits of wood assembled on land they are squatting on. For the record, what is considered 'poverty' in the United States would pass as considerable affluence in Mexico. So if you have non-sailing friends thinking about taking a winter vacation, suggesting Cabo as a destination is not the least charitable thing that you could do.

— latitude/rs 11/15/2014

Cruise Notes:

"I'm in Malaysia now," reports Tom Van Dyke of the Santa Cruz-based Searunner 31 trimaran **En Pointe**. "I skipped Singapore for many reasons, one of them being that the authorities now require every boat to have an AIS transceiver as well as an AIS receiver. When I got to Thailand, I found they are requiring the same thing! Maybe I'm naive, but didn't think having just a receiver was going to be a problem."

Actually, Van Dyke is not quite correct, as the Thai requirement only applies to foreign-owned vessels. In the case of Thai-registered vessels, they can carry up to 22 passengers — and be operated rather wildly — with-



out meeting the AIS receiver *and* transceiver requirement. Also curious is the fact that the requirement for both an AIS transceiver and receiver came less than a month after Phuket Governor Maitri Inthusut signed legislation requiring that foreign boats have *only* an AIS receiver. It is believed to mark the first time in history that one arm of a government hasn't known what another arm was doing.

Seeing as Thailand is 95% Buddhist, you'd assume that officials would be lenient about giving foreign boatowners time to get the new units. After all, there is no West Marine Superstore in Phuket. And they are being lenient.

"For boats that arrive in Phuket with captains who don't know about this new order, we can give them about 10 days to obtain an AIS transceiver," explained Phuripat Theerakulpisut, chief of the Phuket Marine Office. "But those who ignore our requests will be charged for disobeying an order issued by the Na-



IN LATITUDES

SINGAPORE VISITORS BUREAU



To each their own, but there is much to see and do in the overachieving city/state of Singapore. Clockwise from above; Downtown at night. Merlion could get a big fine for spouting. Sentosa Island. The incredible skyline. The Sultan Mosque. And lastly, the roof of the Marina Bay Sands Hotel.

tional Council for Peace and Order, and can be jailed for up to six months." Om.

We're surprised that Van Dyke, a vet of the 2012 Ha-Ha, would bypass **Singapore**. Sure, it's steaming hot year round and very crowded, and you can get into big trouble for committing minor offenses such as spitting or spraying graffiti. On the other hand, it's one of the great and dynamic cities of the world. Consider what it has to offer:

1) One of the lowest crime rates in the world. 2) The healthiest people in the world. 3) One of the least corrupt countries in the world, where no distinction is made between white-collar and blue-collar crime; 4) A superb education system, where teachers are highly respected and well paid. 5) The lowest drug abuse rate in the world. Oddly enough, despite all this tremendous achievement, a recent

Gallup report revealed that Singapore's wealthy population is the unhappiest, or the "least positive," in the world. Less happy, in fact, than people in Iraq, Haiti, Afghanistan and Syria. Less happy that Syria?! Maybe it wasn't a bad idea for Van Dyke to skip Singapore after all.

"We're in San Carlos, Sonora, Mexico getting our boat ready for another season of cruising," reports Sandy Edmonson of the Morgan 41 **Faith**. "I was perusing the November issue of *Latitude* when I came across the letter from Rob and Linda Jones regarding paperwork for Mexico. In *Latitude's* response you stated that "because you got your fishing license from the Mexican government as opposed to H&M Landing in San Diego, it's only good until the end of the calendar year, not for 365

days". Well, we stopped in San Diego on our way south, as we do every season, and purchased our fishing licenses from the CONAPESCA (Mexican government) in downtown San Diego. Our licenses are valid from Nov. 3, 2014 until Nov. 2, 2015, not just to the end of the calendar year. I just wanted to correct that misconception. By the way, the weather is lovely here."

Thanks for the correction. Here's how we got it wrong. When Doña de Mallorca went to **CONAPESCA** to get fishing licenses for us in late October, they were only good until the end of the calendar year. What the gentlemen at the counter had failed to tell her is that for just a few dollars more, she could have gotten licenses for a full 365 days. Maybe that should have been mentioned before she bought the license, which couldn't be changed once it had been purchased.

Despite this, de Mallorca found the two Conpesca guys, who have both worked there for 30 years, to be charming. One told her that he hasn't been able to celebrate his late-October birthday since the Ha-Ha started 21 years ago because of all the Ha-Ha fishing licenses he has to process. "But I don't mind," he said, "as I love to meet all the people."

Chilly, but better late than never. Marc Wilson reports he departed Newport, Oregon on November 15 bound for sunny Mexico, skipping the Catana 52 **Bright Wing**. He advised they were doing 10 to 12 knots in an easterly, and that it was very clear — but very cold. The November 20 high for San Diego was only the mid-60s. Time to be long gone south of the border if you want to be warm.

What's this, someone making a change in cruising plans? "We're not going to be spending the winter in the Caribbean after all," reports Greg King of the Long Beach-based 65-ft schooner **Venezuela** has many very serious problems with crime and finances. *There is no problem with the beauty of its Los Roques Islands.*



VENEZUELA TOURISM

CHANGES

Coco Kai. "We left Grenada a week ago on our way to Panama and the States with new crew of Carsten and Connie from Kiel, Germany and myself. We had a very nice two-day sail to Los Roques, Venezuela. We only get 15 days here to explore the hundreds of reefs and isles. The water is a perfect 84.2 degrees, and the trades are blowing 12 to 18 knots, keeping us a bit cooler. But I kind of feel like the captain of a charter boat, as we have been moving from spot to spot daily. The snorkeling is great. We'll soon be stopping at an island where they breed albino loggerhead turtles, which are very pretty. But I can't wait until Jennifer, my girl, and her daughter, Coco, meet up with me for 10 days or so over Thanksgiving at Curaçao and Aruba."

More changes in cruising plans: "We just arrived in Bonaire after a great three weeks in the remote islands of Venezuela," King wrote in an update. "My girls arrive on Saturday and we'll sail to Curaçao and Aruba. Unfortunately, my German crew had leave for home early for business, so I'm looking for crew from Aruba to at least Panama."



TALION

Dennis and Susan Ross, richly deserving of acknowledgment for running the SSCA's top Cruising Station.

Unless there are additional changes in plans, King and *Coco Kai* will soon complete an eight-year circumnavigation.

The best out of 200! Congratulations are due **Dennis** and **Susan Ross** of La Paz, as they have been selected by the 5,000-member Seven Seas Cruising

Association as the winners of the Bate-man Cruising Station of the Year award for 2014. There are almost 200 SSCA Cruising Stations around the globe, providing information and assistance to cruisers who are visiting the local cruising grounds. The station hosts are a clearinghouse of information about local conditions, maritime-related services, and local community activities.

Dennis and Susan joined SSCA in 1997 when they were first contemplating purchasing a sailboat for full-time liveaboard cruising. In 2002, the couple took early retirement, bought the Endeavour 43 **Two Can Play**, and started their cruising life in the San Diego area. Within a few weeks they moved their sailboat to Ensenada to refit her for bluewater cruising. For the next five years they cruised all of the Pacific Coast of Mexico, as far south at Huatulco and as far north as the upper reaches of the Sea of Cortez. In 2007 they settled in La Paz and started Ross Marine Services and Consulting.

"We decided to do a book signing of

**Enjoy
Latitude 38...
Anytime,
Anywhere,
Absolutely
FREE!**

Latitude 38 eBooks
www.latitude38.com

**MARINA DE LA PAZ
FULL SERVICE MARINA**

Friendly, helpful, fully bilingual staff

Hardwood docks • Protective piling & sheetpile breakwater
Plug-in Internet • Dinghy landing • Cruisers' clubhouse
Electricity • Potable reverse osmosis water • And more!

TEL: 01152 612 122 1646
email: marinalapaz@prodigy.net.mx
www.marinadelapaz.com
Apdo. Postal 290, La Paz, 23000
Baja California Sur, Mexico

Official Sponsor
2014
BAJA
HA-HA

**VENTURA HARBOR
BOATYARD**

**For All Your Haulout Needs
Two Travelifts ~ 160 & 35 Tons
Full Line of Marine Services
(805) 654-1433
www.vhby.com**

Jeff's *Cape Horn: Forever on My Mind* at Downwind Marine in San Diego just before the Ha-Ha, and then Jeff was invited to do another the next day at West Marine," report Jeff and Debbie Hartjoy of the Seattle-based Baba 40 **Sailors' Run**. "So the rest of our four days in San Diego were spent chasing down boat parts. Our 2½-hour Greyhound bus ride from San Diego to Mexicali was pleasant, but crossing a foreign border with thousands of dollars of boat gear, even if what you are doing is legal, always generates anxiety. But the Mexicali authorities were very helpful. In fact, they carried two of our six suitcases for us! From Mexicali we took an ABC bus to San Felipe, which took a couple of more hours, and then were aboard *Sailors Run* again.

"We then headed south," the couple continue, "with a stop at Gonzaga Bay. Our anchorage there started to go bad when a strong westerly developed overnight, so we blasted out of the bay as the sun was coming up. We had a great sail to 45-mile-distant Refugio. Once we arrived, the winds subsided, and we

had a peaceful evening in a beautiful anchorage — until the wind came up again at 2 a.m.

"Every since Jeff rode out Odile on the hook, he can't stand waiting to see if things get worse," said Debbie, "so he roused me from a sound sleep and had me stumble into the cockpit and behind the wheel. I thought it was a little crazy heading out into building southwesterly winds and seas on a moonless night."

"Having Debbie at the helm after having done 2,200 miles during five months in the Sea over the summer was a real relief," says Jeff, "as it's hard to deal with such situations by yourself. And since my near miss with Odile, I don't want to ever again become trapped in an exposed anchorage. I prefer to take my chances in heavy weather on the open sea. And we did fine."



Cape Horn vet and around-the-world aspirant Jeff, on the left, and Debbie, on the right, are photobombed by a beaming young lady.

"We were anchored in Bahia de Los Angeles on October 28 and were searching the SSB radio when we heard the Grand Poobah taking roll call for the second day of the Ha-Ha," says Debbie, picking up the conversation again. "Even though the Poobah was all the way across the Baja Peninsula in the Pacific and at 34°N, while we were down at 28°N, his voice was amazingly loud and clear. We could hear most of the

 *Happy Holidays from the Spectra Team!* 

After crunching the numbers,
real cruisers choose Spectra.

Up to 8x more energy efficient than
the competition.

That can add up to thousands in fuel
savings or a smaller solar array, wind
generator, or battery banks.



415.526.2780 www.spectrawatermakers.com



www.swedishmarine.com



www.outboundyachtservices.com



www.emeraldharbormarine.com



www.seatechmarineproducts.com

CHANGES

responses from the boats pretty well, too. Afterwards we went into 'town', and you never would have known that a hurricane had come through just six weeks before. The streets were so clean, the stores looked great, and everything was back to normal. Well, not everything, as the lady in the store said a hill came down and wiped out one of the schools. Fortunately, there were no deaths."

Cabo, La Paz, Bahía de Los Angeles, from all we've heard, all have bounced back very well from Odile.

Looking for a great place to have dinner in Puerto Vallarta? John and Gilly Foy of the La Cruz-based Catalina 42 **Destiny** recommend **Hacienda San Angel** for dinner. "It's the most magical place you can imagine, as it's a *hacienda* on the side of a hill with beautiful grounds, incomparable views, and a menu with delectable choices. They had a 12-member mariachi band with eight violins and great voices for background. If that weren't enough, Janice, the woman who owns the restaurant, is the heart and soul of the Puerto Vallarta SPCA.

Looking for good food in the north



DOCK 7

Service with south-of-the-border smiles. Dock 7's Grant Todd surrounded by his great team of Martha, Erika, Alejandra, Dénia and Karina.

end of Mazatlan? Lots of folks rave about the popular **Dock 7** at Marina Mazatlan, which features all kinds of great fresh seafood as well as most big sporting events on television.

Have a **favorite restaurant** in Mexi-

co? Tell us about it.

"We're currently at Tenacatita Bay, and decided to take a dinghy trip up the estuary to the lagoon and beach at 'the Aquarium'," report Rob and Andi Overton of the Hampton, Virginia based Stevens 50 **Akka**. "It's a trip described on page 126 of *Pacific Mexico, A Cruiser's Guidebook*, and on page 266 of *Charlie's Charts for Mexico*. Alas, the trip to the lagoon and beach is no longer possible. About two-thirds of the way up the stream we came to a new canal on the right, which is straight and wide, but doesn't lead to anywhere interesting. We pushed on along the estuary beyond the canal, only to encounter a half-sunk *panga* blocking the estuary. With some effort from our 15-hp outboard, we were able to bull our way past into the mangroves. After that, the estuary became almost impassable in places, with mangrove branches clogging the route both above and below the water.

"Despite these obstacles," the couple continue, "we made it to the lagoon, only to discover that the *palapa* at the edge of

CALL NOW!
HOLIDAY DISCOUNTS IN EFFECT

Watermakers Since 1987

SPARKLING FRESH WATER, POWER, REFRIGERATION AND AIR CONDITIONING FROM THE SEVEN SEAS

110 VOLT / BELT DRIVE

HYDRAULIC

AQUAGEN 150

MODULAR KIT

MITGEN 150

UPGRADE MOUNT

316 S/S REMOTE PANEL

12 VOLT DC

AquaGen combines the quality, simplicity & reliability of AquaMarine, Inc. watermakers with the durability of the Kubota 150 amp 12V diesel generators. This compact low fuel consuming AquaGen is a powerhouse, capable of producing up to 150 amps, and 8 up to 62 GPH of fresh potable water from any water source. Make fresh water, refrigeration, and also charge your batteries all at the same time! A hydraulic pump may also be added to run your dive compressor, windless, bow thruster, or emergency bilge pump. Ideal for longterm cruisers or weekend wanderers. We custom engineer our systems to fit any size vessel or cabin site. Electric, Hydraulic, or Belt Driven Modular Kits are also available. Visit our Website for more information.

QUALITY AT AFFORDABLE PRICES.
LIFETIME WARRANTY ON PUMP HEAD AND PRESSURE VESSELS.

AquaMarine, Inc., 58 Fawn Lane (P.O. Box 55) Deer Harbor, WA 98243 USA
(800)or(360) 376-3091 Fax (360) 376-3243

www.aquamarineinc.net

Start Line Strategies

Winning Legal Strategies For Yachting

12+ years America's Cup Experience

Sponsor & Venue Arrangements • Crew Contracts
Vessel Shipping Logistics • Charter Agreements

Ashley Tobin

(925) 324-3686 • amtobin2@gmail.com

After hours pick up and drop off available.

Specializing in Sail Repair and Used Sails.

Marchal Sailmakers

2021 ALASKA PACKER PLACE, ALAMEDA, CA 94501
Dominic Marchal • (510) 239-5050
www.marchalsailmakers.com

the lagoon is abandoned. Finding a hole in a chain link fence, we went across to the road along the beach. There are no longer any restaurants, *palapas*, or *tien-das*. We were, however, met by an armed private security guard who informed us that we had just crossed private land and had to leave immediately. He then got on the radio and reported our presence to somebody. As we backtracked, we noticed a large occupied building on the private property, with what appeared to be people in black uniforms running about. Dogs barked from the back of the house, too. We left with alacrity."

The deal is that the entire area was the subject of a decades-long legal dispute between a wealthy man and many 'little people'. You're not going to believe this, but the rich guy actually won for once. He knocked down all of the little businesses and fenced off the area. If we're not mistaken, the 'Jungle Ride' hasn't been doable in several years now. It's a pity.

If there is one corporation in the United States that we loathe, it's **AT&T**

because of its complicated and constantly changing plans and policies, because they keep you waiting on the phone for hours, and because too many of their online tech people aren't even familiar with their latest products. But for AT&T customers planning to cruise to Mexico, there may be a little good news on the horizon.

Thanks to the Mexican government's moves to increase competition, a company controlled by Carlos Slim has had to divest itself of its shares of Lucacell cellular in order to get beneath the new 49% maximum market limit. AT&T was the buyer of Lucacell.

"It won't matter what country you're in or what country you'll be calling," said AT&T Chairman Randall Stephenson, referring to the United States and Mexico,



If you're an Internet junkie, it's comforting to be able to get even slow Internet service at places as remote as Bahia Santa Maria.

"it will be one network, one customer experience." And hopefully one economical, easy-to-understand, and stable plan.

For what it's worth, using our new iPhone 6+ — what a great device! — we were able to surf the net while at anchor at both **Turtle Bay** and **Bahia Santa Maria**. Not at high speed, mind you, but it was usable. And after leaving Cabo, we were able to get Internet about 14 miles from shore.

With lots of first-time cruisers heading up into the Sea of Cortez while the

CRUISING SOUTH?

Need Power? We Can Help!



PACKAGE DEALS!

Sales and Service –

- HO Alternators & Pulley Kits
- Wind Generators
- Solar Charging Systems
- Watermakers

**FIRST WATCH MARINE
(619) 916-1730**

www.sandiego.marinesmartenergy.com

weatherguy.com

**Worldwide Marine Forecasts
Cruising, Racing & Commercial**

Packages Starting at \$65.00 USD

(866) 882-WXGY (9949) toll free
(808) 291-WXGY (Mobile)
(808) 254-2525 (Office)
(808) 443-0889 (Fax)



970 N Kalaheo Ave
Suite C-104
Kailua, Hawaii 96734
info@weatherguy.com

www.weatherguy.com

SAIL NAKED

Just leave your Hydrovane on

Totally independent self-steering windvane **AND** Emergency rudder... in place and ready to go.

- No lines to the wheel
- No power consumed
- No worries - the ultimate redundancy for offshore
- Mount off centre
- Your best crew member ... doesn't eat, sleep, or care what you wear!



ECHO Tec Watermakers

watt&sea



www.hydrovane.com

STEERING THE DREAM

CHANGES



Stingrays are cute and friendly. But if you accidentally step on one, it will lance you and cause childbirth-caliber levels of pain.

water is still warm, we hope that everyone will be on the lookout for **stingrays**, and knows how to treat being lanced by one. Unlike Cabo, where there are no stingrays, there are gazillions of them in the sandy shallows of the Sea of Cortez, particularly around La Paz in the fall and spring. The best prevention is shuffling your feet when walking in sand, but even that isn't a guarantee not to be hit by a reflexive assault. Some people think that booties or reef walkers offer adequate protection. They do not. If you do get 'stung', expect to experience the most excruciating pain you can imagine. The best treatment is to continuously pour water as hot as you can stand over the wound, as it will eventually denature

the proteins that cause the pain. But it will take hours. There are some strong painkillers that can be purchased over the counter in Mexico, but you need to check with a doctor before taking them,

and even they don't mitigate much of the pain. And the lance must be removed to eliminate the threat of severe infection. Be careful!

"I believe there was some confusion in the *Changes* article of ours that was published in the November issue," write Mike Wilson and Melissa Harter of the Mazatlan-based S&S 44 **Tortue**. "We never mentioned *elephant*s, which are entirely different from *chubascos* and *torritos*, which I did mention. The latter two are born from tropical moisture cells — convection — interacting with the drier and cooler air in Baja, or the drier air over the mainland, depending on flow patterns. This causes vertical wind shear and resultant thunderstorms, lightning, wind and rain. In general, lo-

calized winds known as *elephant*s and other such names are from katabatic or anabatic effects due to differences of temperature of the land and sea, i.e. the diurnal effect. Please clarify this so the weather gurus don't take me for being dumb."

Our apologies, as the mistake was an internal one on *Latitude's* part.

For the last two winters the Poobah had hoped to put together some sort of **Tenacatita-Barra de Navidad Sailing Festival** in early January. Last year the idea got derailed by the Mexican IRS's misguided blunder of impounding foreign boats. We regret to report that there is a reason we're not going to be able to do it this year, either — the Poobah is pooped. After running the Ta-Ta, the unusually challenging Ha-Ha, and the Banderas Bay Blast/Pirates for Pupils, in addition to doing *Latitude 38* and *Lectronic*, the Poobah is going to hold off from starting another special event. But we hope someone else picks up the idea and runs with it. We know that Dino, the Harbormaster at the **Grand Marina is Barra** likes the concept. How about it, 'Mayor of Tenacatita Bay'?

Specializing in Complete Packages

SEATECH SYSTEMS™
 800.444.2581 · 281.334.1174
 info@sea-tech.com · www.sea-tech.com

Navigation, Communication & Weather

NEW AND USED SAILS!

Specializing in production boats and featuring the largest selection of stock sails available anywhere! Save with warehouse volume discounts on Stock Sails, Custom Sails, Sail Covers, Furlers and Accessories. All top Quality.

All Fully Guaranteed!

- Full Batten Mains
- Furling Genoa's
- Storm Jibs
- Trysails
- Furling Units
- Custom Canvas
- Used Sails

THE SAIL WAREHOUSE

Ph. (831) 646-5346 www.thesailwarehouse.com

Latitude 38 Special
\$1095 - 2 certifications
 5 nights lodging included
San Francisco Bay

MODERN SAILING SCHOOL & CLUB
 (415) 331 - 8250
 www.ModernSailing.com

ASA **Outstanding Sailing School**

NEED CASH FAST?

Advertise your USED MARINE GEAR
 in our *Classy Classifieds*
THIS STUFF SELLS FAST!
 Deadline is the 15th at 5pm. See page 120 for details.

JUST YOU AND THE SEA...

Punta Mita Beachfront Condos

Call now for winter reservations!

(415) 269-5165

www.puntamitabeachfrontcondos.com

Mathiesen Marine

For all of your electronics and electrical needs

Professional Sales, Design, Troubleshooting, Installation, Consultation, Education & Surveys for Electronics, Electrical, PC/Mac Based Navigation, Corrosion Issues, Electric Drive Conversions + More

*Wishing you a safe & happy holiday season!
We hope to serve you in the New Year!*

Emery Cove Yacht Harbor Showroom
3300 Powell Street, Emeryville, CA
Tuesday - Saturday 9:30 a.m. to 4:30 p.m.

510.350.6622 www.MathiesenMarine.com



*A Sailor's
Consignment
Chandlery*

NEW & USED BOAT GEAR

Open Tues.-Sat. 10 to 5 p.m.

510-769-4858

Located at Grand Marina

www.bluepelicanmarine.com



NEW IN 2015

New Look • New Website
Same High Quality Products
Same Legendary Customer Service

- LED & CFL Overhead Lights
- LED Reading & Berth Lights



(406) 889-3586
WWW.ALPENGLOWLIGHTS.COM



MARINE BATTERIES



Available at the following local marine chandleries and service distributors:

- | | |
|---|---|
| ALAMEDA
The Boatyard at Grand Marina
Star Marine
Svendsen's Chandlery | MARTINEZ
Martinez Bait & Tackle |
| BENICIA
Cruising Seas Services | OAKLAND
Outboard Motor Shop |
| EMERYVILLE
Mathiesen Marine | OAKLEY
Big Break Marina |
| | RICHMOND
Swedish Marine
Bay Marine
KKMI |



AMERICAN BATTERY • Hayward, CA • (510) 259-1150

Please read before submitting ad

Classy CLASSIFIEDS

Here's What To Do:

Write your ad. Indicate category. Remember price and contact info. We make final placement determination.

Count the words. Anything with a space before and after counts as one word. We will spell-check, abbreviate, edit, as necessary.

Mail your ad with check or money order, deliver to our office; **OR, for the best - and most exposure - of your classified ad...**

Submit your ad safely online with Visa, MasterCard or AmEx at: **www.latitude38.com**

Ad will be posted online within two business days, appear in the next issue of the magazine, and remain online until the following issue is released.

PERSONAL ADS

1-40 Words.....\$40
41-80 Words.....\$65
81-120 Words....\$90
Photo.....\$30

• Personal Advertising Only •
No business or promo ads except Non-Profit, Job Op, Business Op

'Trying to Locate' Ads are for those searching for lost boats/people - not shopping - and cost **\$10 for 20 words max**

FREE Online Ads are for a private party selling a boat for less than \$1,000 - or gear totalling under \$1,000. (One per person; must list prices in ad.)

All ads will be set to fit *Latitude 38* standard • Re-Run Ads: Same price, same deadline

BUSINESS ADS

\$70 for 40 Words Max

• All promotional advertising •
1 boat per broker per issue
Logo OK, but no photos/reversals
No extra bold type • Max: 12 pt font
Artwork subject to editor approval.
Biz ads will not appear on website.

DEADLINE

it is **ALWAYS** the **15th at 5 pm**

for ad to appear in the next issue.

Due to our short lead time, deadlines are very strict and include weekends & holidays.

Sorry, but...

- No ads accepted by phone
- No ads without payments
- No billing arrangements
- No verification of receipt
- We reserve the right to refuse poor quality photos or illegible ads.

Latitude 38 15 Locust Ave, Mill Valley, CA 94941 Questions? (415) 383-8200, ext 104 • class@latitude38.com

WHAT'S IN A DEADLINE? Our Classy Classifieds Deadline is the 15th of the month, and as always, it's still pretty much a brick wall if you want to get your ad into the magazine. But it's not so important anymore when it comes to getting exposure for your ad. With our online system, your ad gets posted to our website within a day or so of submission. Then it appears in the next issue of the magazine. So you're much better off if you submit or renew your ad early in the month. That way your ad begins to work for you immediately. There's no reason to wait for the last minute.

9-FT FATTY KNEES DINGHY. Moss Landing. \$2,500. With oars, oarlocks, rub rail, skeg, rudder, mast, sail. Great shape. Strong easy sailer, with a lifetime of adventures at the ready. (831) 747-7440 or tireboyaux@mac.com.

24 FEET & UNDER



20-FT HARBOR, 2015. Corona, CA. \$35,000. I have four (4) 2015 Harbor 20's; three are being built right now. One is ready to be delivered anywhere. Great class and great class association. If interested please call and I can send you more information. They are priced to sell fast. Please only serious inquiries! Contact: (415) 724-8566 or (415) 944-8028 or alfonso94970@gmail.com.

24-FT STONE HORSE. BY EDIE & DUFF, 1976. Alameda Marina, CA. \$14,000. 2005 new Beta Marine 14, Awlgrip hull and mast. New 2014: standing and running rigging, staysail, two furlers, shaft, prop, stuffing box, bottom paint, berth cushions. (510) 553-1987 or 703-7050 or flickasf@aol.com.



23-FT RANGER, 1976. Brickyard Cove. \$4,250. Good condition, dry boat. Perfect for singlehanded in strong Bay conditions. 5 sails including spinnaker, double lifelines, 2011 Tohatsu 6hp x long shaft. Bottom repainted 2012. 30amp shore power, recharger, Porta-Potti, marine radio. Contact: danielncf@aol.com.



24-FT YANKEE DOLPHIN, 1967. Eureka, CA. \$9,500. Classic Sparkman & Stephens-designed midget ocean racer. Full keel with centerboard, solid, offshore-capable pocket cruiser. Full galley, private head with flush toilet, V-berth and double berth. Well cared for and updated, regularly sailed. Great sail inventory, new main 2012. Much equipment including new autotiller, GPS/chartplotter with depth display, etc. Call (707) 599-4633 or email: bigilwave@gmail.com.

19-FT WEST WIGHT POTTER, 2010. Alameda. \$13,500. Sweet boat, clean and ready to sail. Premium package with upgrades. 2011 Mercury 4hp, bottom painted 7/14, roller furling jib, bimini, on new trailer. Call (510) 865-2266 or email suevee1010@msn.com.

25 TO 28 FEET



26-FT MARIHOLM. International folkboat 2149, 1975. Richmond Yacht Club. \$18,000. Boat purchased new. Original owner. Never abused; always finished near last when raced (not the boat's fault). In excellent condition. Original finish, fiberglass hull, aluminum spars, rigid vang, self-furling jib, Dutchman system for main, two spinnakers and poles. Autohelm, toilet, Volvo factory diesel MD-7, dodger, full and sail covers. I love this boat. Wife threatens divorce if no ad! Call (415) 297-7262 or (415) 775-5131 or email: arhat60742@mypacks.net.



DINGHIES, LIFERAFTS AND ROWBOATS



16-FT PEAPOD ROWING DORY, 2006. Pt. Reyes Station, CA. \$3,500. Aluminum rowing dory on trailer. Two rowing stations, built-in flotation. One of a kind, very fast and stable. One pair of oars, two new life jackets. Please contact: jonathanlangdon114@yahoo.com.

WOODRUM MARINE

Specializing in custom interior cabinetry, tables, cabinets, countertops, cabinsoles. For power or sail.

CARPENTRY
Mobile cabinet shop
Contact Lon Woodrum at:
415-420-5970
www.woodrummarine.com

N.E. MARINE TITLE

Coast Guard documentation • Title/lien searches • Transfers • Mortgage filing • Escrow services
Local closing facility for brokers or private transactions
30 years experience of doing it right the first time

1150 Ballena Blvd, Alameda, CA • (510) 521-4925



NOR-CAL COMPASS

Adjustment • Sales

Authorized Compass Repair

Hal McCormack • norcal.compass@verizon.net • Phone/Fax (415) 892-7177

Capt. Alan Hugenot • (415) 531-6172 • Accredited Marine Surveyor

ASA Certified Offshore Sailing Instructor

Power boat handling & docking, single or twin screw,
35 years sailing sloops, ketches, schooners & catamarans
SF Bay or Coastal • Accepts all credit cards





25-FT PACIFIC SEACRAFT, 1976. DeSabra, CA. \$27,500 w/trailer. With like-new EZ Loader trailer. Boat is cruise equipped. No expense spared on this beauty. Must see! Download the slideshow: <http://tinyurl.com/pfb3nxl>. (530) 518-6181 or vjohannes@gmail.com.



CATALINA SAILBOAT. Models: C-22K, C-27K, C-250K, Coronado, CA. Best offer. Government liquidation through online auction. Event #13362. Bidding opens: November 12, 2014 at 12am EST. Bidding closes: November 14, 2014 at 5pm EST. Opening bid: \$25. 17 lots available. Description: 16.5 to 27 ft. Years ranging from 1971 to 2001. For more information text: (480) 744-2204 or visit the website: www.govliquidation.com/events?cmd=details&event=13362. Contact: (480) 905-2982 or email: ilinquries@liquidityservices.com.



25-FT NORDIC FOLKBOAT, 1992. SF Marina-East. \$18,800. Nordic Folkboat US 115, built in 1992 at Classic Boatworks. Fiberglass hull, wood cabin house. Very good condition. Raced in fleet. Possible berth transfer. (415) 271-6267.



27-FT CAL 2-27, 1975. Redwood City. \$6,300. Standing rigging and lifelines replaced 2010. Roller furling, new jib. Good singlehand boat with Raytheon autopilot, all lines led to cockpit. Universal M-18 (2-cylinder) diesel, folding prop. (408) 841-6648.

27-FT CATALINA, 1974. Richmond Yacht Club. \$4,500. Atomic 4 rebuilt engine; runs well. Equipped for Bay and Delta cruising. Depth sounder, GPS, pressurized cold water, 2-burner alcohol stove, portable potty, autopilot. (510) 559-9706 or royhow@comcast.net.



27-FT NOR'SEA AFT CABIN CUTTER. 1977, Santa Cruz Harbor, \$26,500. Lyle Hess-designed world cruiser. Trailerable. \$20K restoration and partial refit. You add cushions, electronics. See website for photos, history, details. <http://www.sites.google.com/site/norsea27forsale/home?> Contact: (832) 345-9384 or email: lewiskeizer@gmail.com.



27-FT HILLYARD WOODEN SLOOP. 1937. Treasure Island. \$15,000. *Lady Sarnia* was built by Hillyard Boat Yard in England in 1938. A classic 3/4 rigged sloop. Yanmar diesel. Multiple surveys over the years find her in great shape. Lovingly cared for. Reconditioned by Spaulding Boat Works in Sausalito in 2012. Hauled at SF Boat Works August, 2014 for engine check, bottom paint, and topsides paint. Great day sailing and overnighting boat for the Bay. Have to sell as I now live inland for most of the year and can't give her the use she deserves. A sweet boat. Contact (415) 407-8772 or stausch@gmail.com.

29 TO 31 FEET

30-FT ERICSON, 1986. Redwood City. \$17,900. Good singlehandling with self-tacking jib. Harken roller furling. All lines led to cockpit. Raytheon autopilot. Main sheeting traveler on cabin top. Universal M-18 diesel. Teak and mahogany interior. Call (408) 243-2659.

30-FT CAPO, 1984. SFYC. \$15,000. A Carl Schumacher-designed racer/cruiser with standing headroom. Boat is in great shape, but the mast has a crack and needs to be replaced. Great value for project-minded buyer. More info at: <http://tinyurl.com/toybox1>. Contact: (415) 488-3317 or pjcampfield@yahoo.com.

30-FT ERICSON, 1979. San Francisco. \$12,000. Newly rebuilt Yanmar diesel, two-year-old North sails, wheel steering, spinnaker and pole, self-tailing winches, Harken roller furling, cockpit cushions, grill, pressure water, holding tank, stereo and Bose speakers, VHF, anchor. Contact: gallagher415@gmail.com.

30-FT CATALINA, 1977. Alameda. \$14,500. Professionally installed Universal M3-20 18hp diesel. Solid, roomy, fun. Tiller. Quarterly bottom scrub, zincs. Yearly engine tune-ups. Simple, sweet boat. For pictures and more info: <http://bit.ly/1t1RWpg>. Call: (415) 378-3373 or email: chefjohnthiel@sbcglobal.net.



30-FT J BOAT, 1987. Redwood City. \$32,500. Last J/30 built, hull #546. Extras include Harken lazy jack, Xantrex charger, Raymarine tiller pilot, MarineAir reverse cycle A/C. Recent paint. And more. Please call: (954) 325-3768 or (954) 868-9170 or email: ecmx39@gmail.com.



30-FT ANDREWS, 1982. Sausalito. \$5,000. Old MORC racer. Yanmar 13hp engine, runs well. (707) 488-2055 or (707) 445-0100 or email: likhitanski@aol.com.

31-FT HUNTER, 2008. Sausalito. \$76,500. Perhaps you sailed her and loved it, now you can own her! *Gute Fahrt II*, always professionally maintained, great condition, one-year-old main and bottom paint, dodger, wheel steering, Yanmar diesel, in-mast furling main, roller furling jib, completely outfitted with everything you need for a great daysail or weekend on the Bay/Delta. Call: (916) 424-0444 or email: barmo@hotmail.com.

30-FT WYLIECAT, 1998. Oxford, MD. \$75,000. Diesel inboard, custom tandem-axle trailer. Raymarine instruments, 4 sails, dodger, autopilot, installed battery charger. Used seasonally and dry stored, or on lift. Contact: (727) 641-5688 or (727) 502-0186 or hallpalmer@hotmail.com.



30-FT FISHER MOTORSAILOR, 1977. Benicia. \$58,000. Strong, stable, comfortable ride in all conditions. Total refit last 4yrs including re-power with 60hp Isuzu, bow-thruster, new prop, shaft, electronics, tanks, every pump, hose, and wire! Imagine sailing dry and warm, flicking a switch from the pilothouse to drop all-chain anchor, taking a hot shower, and relaxing in custom fantail stern-room. *MaxSea* sails and powers well; even trophied in 2014 Jazz Cup! Rare documented 9-ton classic. More info at: www.fog-northamerica.org. Contact: (916) 719-9355 or micgoose@aol.com.

30-FT CAL 3-30, 1974. San Rafael, CA. \$11,950/obo. Completely redone, 7 bunks, A4 rebuilt, 8 sails, 2 poles, new stereo, depth, GPS, bottom paint, oiled teak interior, large cockpit. (415) 386-4509 or romanrivas@sbcglobal.net.

32 TO 35 FEET

32-FT WESTSAIL, 1975. Pillar Point Harbor, Half Moon Bay. Best offer. Launched in 1980. Original owner. 3 headsails, one drifter, Perkins 4-108, propane stove with oven. Recent haulout, June 2013. Come see, make an offer. Contact: (650) 303-3901 or (650) 712-1425 or email: pgclausen@gmail.com.

33-FT CAL, 1972. Emery Cove Yacht Harbor. \$15,500. Modified stern. Skeg rudder. Tiller. Volvo diesel under 400 hrs. Harken Mk II. Newer rigging. Surveyed in December. Priced to sell. Buy it with a slip for extra discount. (626) 410-5918 or ngolfieart@gmail.com.



33-FT CS, 1981. Sausalito, CA. \$15,000. Sails fantastic. New mainsail, autopilot and new two-burner stove. Interior needs some cosmetic fixes and upgrades. Great opportunity to get into a fun sailing boat at a good value. Email wagskim@gmail.com.



RIGGING ONLY ◊ SMALL AD, SMALL PRICES

Standing and running rigging, life lines, furling gear, winches, line, windlasses, travelers, wire and terminals, blocks, vang, and much more.

~ Problem solving and discount mail order since 1984 ~

www.riggingonly.com • (508) 992-0434 • sail@riggingonly.com

STARBOARD YACHT DELIVERIES



Over 50,000 sea miles • Pacific, Caribbean, Atlantic
USCG Master 100 GT STCW • Power & Sail

Rick Whiting • (415) 740-2924 • captain_rick@sbcglobal.net

MARINE SURVEYOR

Sharpe Surveying & Consulting. SAMS Accredited Marine Surveyor.
Serving the San Francisco Bay and Delta.

RSharpe@SharpeSurveying.com • (510) 337-0706



Afterguard Sailing Academy

The Affordable Way to ASA

ASA Basics to Ocean • Crew Intro to Cruising Prep

(510) 535-1954 • www.afterguard.net



35-FT CHEOY LEE. Robert Perry design, 1981. Barra de Navidad, Grand Marina. \$25,250. We've just DROPPED the price on this actively cruised and upgraded sailing classic, because our circumstances dictate we must change our plans. *Encore* is ready for you to step aboard and enjoy this season sailing Mexico. Everything is onboard, from dinghy & outboard, new radar, EPIRB, pots & pans, pfd's, and more! Check out all details, we may take a small trade. More info at: <http://integratedmarketings.com/sailboat-4-sale>. (916) 458-1882 or espiritu430@yahoo.com.



35-FT RM1060, 2012. Nuevo Vallarta, Mexico. Great cruising sailboat in excellent condition: high-performance sailing, stylish, comfortable and functional design. Epoxy/plywood shell, biquille, interior panoramic view. B&G instruments, Watt & Sea hydro-generator, Volvo Penta 30, freshwater 400L, fuel 130L. Please contact: (521) 551-268-4306 or email: travesiagalina@gmail.com.



32-FT GULF PILOTHOUSE, 1985. Alameda. \$28,000. Full-keel sloop, diesel, 5 berths, microwave, refrigerator, ice box, radar, GPS, VHF, hot water, dual helm, includes davits and 9-ft Achilles and outboard motor. Documented. More photos on request. Phone or email Dick for appointment. (510) 303-9533 or email: dickfolger@aol.com.



34-FT O'DAY, 1982. Alameda. \$25,000/obo. North sails, jib furler, spinnaker. 24hp Universal diesel. Gori folding prop. (7) 2-speed self-tailing winches, Autohelm, 3-burner stove and oven. Refrigeration. New batteries and inverter. Excellent Bay, Delta and club racer. Call (510) 581-4720.



35-FT J/105, 1993. SE Yacht Club. \$65,000. Fully maintained about a year. J/105 per cans and li. Email: owner@seyc.org.



32-FT CELESTIAL, 1990. Monterey, CA. \$39,000. Yanmar 2GM20F rebuilt, roller furler, 2 jibs, spinnaker, Autohelm, GPS, radar, inverter, Racor fuel filters, grill, range, head, holding tank, fenders, boat hook, cockpit table, shore-power cord, tiller extension, backup engine parts. (831) 372-7245 or dutch@montereyssailing.com.



35-FT ALBERG, 1962. Marina Bay (Richmond). \$22,500/obo. Full-keel cruiser ready to go (new life raft, standing and running rigging, lifelines, elec windlass, chain and rode, EPRIB, Vari-Prop, lazy jacks, dodger, radar and much more. Clean. Call (707) 485-5218.



34-FT HANS CHRISTIAN, 1976. Morro Bay. \$12,000. Restoration about halfway. Decks removed to repair dry rot and mold. Decks need reinstallation. The Yanmar 3GMF removed and professionally rebuilt with 1hr. Needs reinstallation. A solid bluewater cruiser. Call (805) 434-2135 or email: twaltnelson@charter.net.

33-FT WAUQUIEZ GLADIATEUR, 1983. Sausalito, CA. \$39,999. Great coastal and offshore sloop. Ready to sail. Pictures and details on website: www.quest33.info. Please contact if questions. (707) 832-3734 or (707) 725-2028 or email: krs1147@aol.com.

34-FT CAL 34, 1969. San Francisco, West Harbor. \$15,000/obo. On Marina Blvd. Berth is transferable! Fantastic boat with great legacy. Needs work, but will sail for another 20 years. Call (415) 385-7190.



35-FT BABA, 1979. King Harbor Marina, Redondo Beach. \$49,000/obo. Bob Perry design. Roller furling, Volvo Penta engine, Honda generator, wind generator, canvas cover, etc. Have to visit! Call (310) 528-2196 or (310) 374-4058.

36 TO 39 FEET

38-FT WATERLINE, 1980. Poulsbo, WA. \$49,000. Professionally built steel sloop, 44hp Yanmar, Hasse sails, So Pac Vet, cruising equipped, great liveaboard. For pictures and more details email us at ironb4sale@gmail.com.



33-FT HOBIE, 1983. Healdsburg, CA. \$16,500. Hobie 33: Ballenger double spreader mast, recent high-tech running rigging as well as lifelines and standing rigging. Halyards led aft for single-/doublehanding. Large sail inventory including new asymmetric jibs in fine condition. Many upgrades including galvanized steel trailer with new SS brake rotors, removable bowsprit, oversized rudder by Foss, Honda-powered 12hp sail drive, Raymarine instruments. The Hobie 33 is an enduring legacy of Hobie Alter, about the biggest bang for your racing buck. (707) 433-3692 or dijon1@sonic.net.

32-FT COLUMBIA 9.6, 1976. Richmond Marina. \$8,000 or best offer. Working Volvo Penta engine MD6B. Full suite of sails, including blooper. Monitor wind-vane. Potential great liveaboard. AS IS: needs work. Please contact: (510) 205-1590 or (510) 290-0797 or email for more information: a-harkness@sbcglobal.net.

35-FT ERICSON, 1977. Stockton, CA. \$21,000. Ready to cruise or race. New 110 jib on new roller furling, wheel steering, Garmin GPS/radar, autopilot, wireless wind indicator, Garhauer boom vang, low engine hours, many extras. Contact: (209) 986-7813 or b_mohr@sbcglobal.net.

39-FT ROBERTS 40, 1980. Mazatlan. \$45,000. Ready to go cruising... AND already in Mazatlan waiting for you! Roomy, sails well. Isuzu diesel, watermaker, solar, wind generator, radar, chart plotter. New 10/2014: bottom paint, dodger, mainsail cover. See <http://svendeavour-ca.webs.com>. Email: mangoman2@gmail.com.

35-FT BENETEAU, 2006. Emery Cove Marina, Emeryville, CA. \$198,000. Excellent opportunity. Fully equipped, only has 100 hours of usage, well maintained. Pay discounted price of \$198,000 for this 98% new boat. Call Mr. Lau for discussion and viewing appointment. You could be the next lucky owner. (415) 200-7012 or lauseinvestment@yahoo.com.

35-FT J/105, 1998. Berkeley Marina. \$64,500. #181, *Wianno*. Top 10 Fleet #1 finisher 2011 and 2012. Excellent condition. Two full sets racing sails, 1 set cruising sails. Race-ready. More information at: <http://picasaweb.google.com/Gnuggat/J105181WiannoForSale#>. Please contact: gnuggat@gmail.com.



37-FT TAYANA PILOTHOUSE, 1978. Sausalito, CA. \$85,000. Original owner, mechanical engineer, Perkins 4-108 2,900 hrs., heavy-duty hydraulic steering, autopilot, forward scanning sonar, 12V refrigeration, teak interior, no teak decks, excellent condition, many extras. Contact: (775) 345-0170 or Altajake@aol.com.



MARINE ENGINE CO.

Complete Engine Services • Gas & Diesel
30 Years Experience • Reasonable Rates
Tune-Ups • Oil Changes • Engine Rebuilding, etc.
(415) 763-9070

DAVE'S DIVING SERVICE

Hull Cleaning • Zincs • Inspections • Props Replaced
Repairs • Recoveries. Fully Insured and Marina Recommended.
(415) 331-3612 • Serving Southern Marin Since 1984



Get the Reliable, Powerful Wheel Pilot

Quiet & Dependable • Affordable • Built for Immersion
Easy Owner Installation • Low Power Consumption
831-687-0541 www.cptautopilot.com



MOBILE MARINE PUMP-OUT SERVICE

\$25 per pump up to 40 gallons.
Includes fresh water flush and a packet of treatment.
20% discount for regularly scheduled service.
www.mobilepumpout.com • (415) 465-0149 • tim@mobilepumpout.com



39-FT YORKTOWN, 1977. Vallejo. \$29,999. Turnkey 39-ft Yorktown sailboat with many upgrades. Well maintained. Very seaworthy. New paint, Harken traveler, Barlow winches, and more. Ready to sail NOW! Reduced price. Very motivated seller. Call for details. (925) 324-4226 or daltonm@scrantonlawfirm.com.



37-FT TAYANA, 1978. Redwood City. \$40,000. Got an ocean to cross? Tayana 37 in bluewater shape priced to sell. Monitor windvane, radar, big water tanks, Perkins diesel, solar panels, wind generator, etc. <http://about.me/a.f.garcia.martinez>. Contact: (917) 628-4497 or email: a.f.garcia.martinez@gmail.com.



45-FT GARDEN YAWL. One off, double-ender, 3 years in restoration, 98% completed, cold-molded over original strip planking. \$30,000 as is, or ? to finish renovation. Contact: (916) 847-9064 or steve@paradigmpilgrim.com.



45-FT FASTNET 45, 1974. Portland, OR. \$67,000. Price reduced!. Beautiful boat, many compliments on her lines. Recently sailed to Australia and back. Very seaworthy, comes with a lot of equipment. Considerable locker space and storage for extended cruising. (503) 327-6750 or lighthouse45@yahoo.com.



38-FT SPARKMAN & STEPHENS, 1971. One Ton sloop. Past winner of Sydney Hobart race. Superb cold-molded kauri pine hull from top New Zealand yard. Attractive cruising interior. Perkins 4/107 diesel with Hurth transmission and MaxProp. Stainless steel fuel and water tanks, good sail inventory with Hood furler. Bottom anti-fouled August 2014. Offshore proven performance. A solid go-anywhere boat looking for a caring owner at a moderate price. Lying Poulsbo, WA. Call (360) 808-1743.



38-FT WILDERNESS, 1983. Morro Bay. \$44,000. Designed by Gary Mull. Boat is in VERY good shape, is super fun to sail, fast and spent the first 20 years in fresh water. I purchased a larger boat and would love to get rid of this ASAP. Newer mid 90's Yanmar 3GMF with less than 400 hours, new Martec folding prop, new shaft, six bags of sails with two mains, carbon pole, sleeps 6, head with 10 gallon tank, 35 gallons of water, 35 gallons of fuel, Raymarine chartplotter and radar, solar panel, original gelcoat hull, Harken-equipped including roller furling. Please contact me for more information or with any questions, concerns or to view! (805) 550-1118 or goldconcept@sbcglobal.net.



40-FT COLUMBIA, 1965. Paradise Cay Yacht Harbor, Tiburon. \$25,000. *Libra*. Beautiful boat. 2nd owner. 1994 25hp Universal 4-cylinder M4-30 414hrs. Runs great. 4'6" draft perfect for the Bay. 7 sleeping berths. More info at: www.dropbox.com/sh/gxjff56ktnxvusa/4REqVVCvoj. Call (415) 948-9801 or maliarmoseley@gmail.com.



44-FT CATALINA MORGAN, 2007. Seattle, WA area. \$265,000/obo. Mint condition. Captain-maintained. Beautiful deck salon, light and airy. 75hp Yanmar, low hours. Batteries recently replaced. Two large solar panels, cruising spinnaker, power winches, hydronic heat, Raymarine C120, radar, autopilot, bow thruster. Found another boat. Must sell. (408) 666-3261 or jerryfsaia@aol.com.



36-FT CAPE GEORGE, 1975. Moss Landing. \$16,000. Junk rig. Solid cruising boat. Hawaii, AK, West Coast vet. North Sails, Aircraft aluminum masts, 4 anchors, Monitor vane, Taylor cookstove, 10-ft dinghy. VETUS diesel. Lots more gear. (831) 682-1620 or svhaiku@hotmail.com.



39-FT CAL, 1971. Oceanside, CA. \$15,000. *Knot A Clew* just repowered, Perkins 4-108 diesel. Lots of racing sails, tiller, fast, race winner. With Oceanside slip. Contact for information (949) 280-6220 or granahan@cox.net.



43-FT SAGA, 1998. Ventura, CA. \$215,000. Rare West Coast offering of this sought-after performance cruiser. Meticulously cared for by second owners. Absolutely turnkey. Panda 4 kw genset, 150 gpd watermaker, hydronic 5-station cabin heat, Icom 802 SSB, carbon fiber sprit pole, cruising spinnaker with snuffer, 200 watt solar panel, 11-ft RIB dingy with 8.0 hp and 3.3 hp outboards. See manufacturer website for further specs: www.sagayachts.com. Contact (805) 985-4532 or lanikai3@live.com.



48-FT SPARKMAN & STEPHENS, 1970. Marina del Rey, CA. \$298,000. Beautiful steel circumnavigator. Recent 18-month total refit 2010-2012! Dutch-built S&S/ Koopman's design, completed by Royal Huisman. *Lola* is a beautiful, fast, seaworthy, circumnavigating machine! No expense was spared in bringing her back to "new" condition from top to bottom! Electronics, rigging, sails, mechanicals, electrical, and paint. All NEW! She is very unique, sails like a dream, and must be seen to be fully appreciated! More info at: www.sailinglola.com. Contact: (707) 509-9096 or mjboucher76@hotmail.com.

39-FT CAL JENSEN MARINE, 1971. Marin. \$17,500/obo. Hull #8. A sweet sailing Bay boat. Needs TLC. Yanmar 30GMF diesel, recent type 27 deep-cycle batteries, good standing rigging, metal spreaders, lines led aft, decent sails, lots of extra gear included. (925) 838-8793 or gspjimrod@sbcglobal.net.

40 TO 50 FEET

45-FT HARDIN VOYAGER, 1979. Mazatlan, Mexico. \$99,000. This liveaboard is set up for cruising, just move on and go. New paint. Email for pics and list of equipment. (408) 844-4565 or (669) 127-9673 or rickhuls44@aol.com.

47-FT CATALINA, \$229,500. Customized bluewater ready. Extra fuel capacity, 110 or 240v, watermaker, chartplotter, radar, AIS, coldplate fridge/freezer. Custom cabinets and workshop, dive compressor, in-boom furler, staysail, autopilot, wind vane, new hard dodger, heat-air, Auto prop. Much more. More info at: <http://adream2sail.publishpath.com>. Contact: (916) 607-9026.

40-FT VALIANT, 1978. Ventura. \$79,900. Hull #198. Outfitted over the past 18 months for cruising. She is in top condition and ready to head south. A change of wind direction has put her on the market. Contact: (805) 754-8897 or email: fsimonds33@gmail.com.



NOTHING COMPARES TO SAILING THE BVI
 We offer the best value, best boats and best experience for bareboating in the BVI.
 Visit us: bvibareboatsailing.com and see what we offer.

OFFSHORE PASSAGEMAKING INSTRUCTION IN THE PACIFIC & ATLANTIC
 John & Amanda Neal are dedicated to providing hands-on, documented instruction aboard their Hallberg-Rassy 46 *Mahina Tiare III*, drawing on their combined 584,000 miles and 73 years of experience.
www.mahina.com • (360) 378-6131

BOAT • LETTERING
alphaboatsue@aol.com + www.alphaboatgraphics.com
 Creative and durable lettering and artwork for your boat

COMPLETE MARINE WOODWORK
 Design / Restoration • Expert European Craftsmanship • Interior / Exterior
 Repairs / Maintenance • Marine Windows & Frame Replacement
 Wood & Dry Rot Repairs • Varnish Work • Marine Painting
 Reasonable Rates • (415) 377-3770 • References Available



43-FT RON HOLLAND, 1986. Marina Riviera Nayarit, MX. \$130,000. Aft cockpit, 2 staterooms, 2 heads, spacious, well equipped and well maintained for cruising. Singlehanded all over Pacific Mexico in comfort and now lying in a fantastic location. See at: www.sanctuarycharters.com/sabbatical.ph. Contact through email: office@sanctuarycharters.com.



41-FT FORMOSA PILOTHOUSE. Ketch in Alameda. \$30,000. Total refit complete of rare version of this salty classic. Rebuilt Ford Lehman, recored deck, rebuilt cabin trunk, new wiring, plumbing and much more. Call (415) 987-8603.



40-FT MODIFIED SANTA CRUZ, 1983. Alameda. \$75,000. Rugged to race. Custom Antrim keel, 1600 lbs lighter, many racing and newer performance cruising sails. Lightly used asymmetric spinnakers. Low engine hours, instruments replaced 2010. Harken roller furler. (408) 807-9630 or egs@alum.berkeley.edu.

CLASSIC BOATS



35-FT CHEOY LEE LION, 1965. Rio Vista. \$20,000. Beautiful 1965, 35-ft Cheoy Lee Lion. Glass hull, Yanmar 30 with around 600 hours, original roller furler boom, new mainsail from Sobstad, one 120%, one 90%. Fresh brightwork, depth sounder, Autohelm, big windlass, two anchors with hundreds of feet of chain. Fresh bottom job and rebuilt cockpit. We take her out on the weekends, so engine time may vary. Email: mrmrsjacobsn12@gmail.com.



40-FT MARINER KETCH, 1972. Marina del Rey, CA. \$27,000. Beautiful mahogany, oak, teak wooden ketch, overall 46'. Hull in excellent shape, will outlast you! New paint-varnish bottom, topsides, deck, masts, interior. 4-108 Perkins diesel. 6'9" headroom. A great sailing, oceangoing vessel you can take anywhere. The most comfortable, fun, easygoing yacht I have ever sailed in 80 years of sailing! If you don't fall in love with this boat you shouldn't buy it! A steal at \$27,000. Contact Tony. (310) 920-1478.



45-FT KANTER ATLANTIC, 1983. Chaguaramas, Trinidad, W.I. \$76,000/obo. Restored, cruise-ready steel pilothouse cutter. New deck, rigging, Awlgrip. Roller main, autopilot, Bluetooth remote, color LCD radar, windvane, solar panels, wind-generator and more. See more photos at: www.boatboss.com/detail-86467/trinidad-tobago/used-yachts/kanter-atlantic-45-pilothouse-bluew. Contact: (580) 220-0573 or email for more info at: Michaelreynolds2005@yahoo.com.



42-FT CATALINA, 1996. Sausalito \$114,500. New bottom paint, new standing rigging, all new rope. Yanmar engine. Autopilot, winches professionally serviced, radar. Excellent condition. Call Tom at (415) 271-2722.

MULTIHULLS



33-FT PROUT QUEST, 1985. Alameda, CA. \$55,000. Cruise the world comfortably, safely, affordably in this strongly built cat. New saloon and master berth, fully outfitted galley. 17 hours on completely rebuilt diesel and restored outdrive. New bottom paint. Call (510) 865-2511.



42-FT CASCADE, 1972. Alameda, CA. \$40,000. New sails, watermaker, Autohelm, new rigging, ice maker, marinized Westerbeke and more. Needs work on deck. Spent a lot, asking for less. Contact: (650) 704-2302 or galaxaura@gmail.com.



44-FT HUNTER 44DS, 2007. In California, \$199,000. Health conditions force us to sell our like-new 2007 Hunter 44DS, cruise-ready. Only 590 engine hours! Standard features, plus in-mast furling, gennaker, boom brake, electric winch; radar, Raymarine E-120, additional displays at nav station, autopilot with remote, AIS, EPIRB, PLB, VHF radio, 2 handhelds; watermaker, 120 gal water, 50 gal fuel, 50 gal holding tank; 56hp Yanmar, upgraded 165 amp alternator, 600ah AGM starting and house batteries, 2.4KW inverter. Hard bottom dinghy, 9.9 four-stroke outboard, heavy-duty davits. Fabulous accommodations, 2 heads with separate showers, centerline queen bed, Bose surround sound system, large flat screen TV, dodger, bimini, near-totally enclosed cockpit! Call (602) 421-9964.



62-FT AL MASON CUSTOM DESIGN. Built in Salthouse, NZ, 1985. Virginia, Chesapeake Bay. Spirit of Tradition ketch, extremely able yacht with pedigree and a history of continuous maintenance and upgrades by knowledgeable owners. Recent circumnavigation and refit. More info at: www.sailmarnie.com. Contact: (757) 971-1811 or sailmarnie@yahoo.com.



52-FT MODIFIED TENNANT. Blade Runner, 1987. Ventura, CA. \$175,000. *Afterburner*, fastest coastal sail catamaran on the West Coast, for sale to a good home. See more at <http://afterburner.gibbsCAM.com>. Contact: (805) 377-1789 or afterburner@gibbsCAM.com.

44-FT BENETEAU OCEANIS 440, 1995. Sausalito. \$25,000. 25% equity partnership. Comfortable safe boat to enjoy the bay on your week every month or share with others. \$300/month covers slip, insurance, maintenance and upgrades. Well maintained by mature knowledgeable owners. Quiet Sausalito slip. Upgraded instruments, radar, AIS, new dodger. Former partner upgraded to larger Beneteau. Sharing is the best way to own a yacht and great boats deserve great partners. Trade for boat, car, plane? Call (949) 338-6298 or email: mjh49@yahoo.com.



55-FT TRIPP A&R, NEW ZEALAND. Incredible yacht, strong, fast, beautiful. Bristol condition. Well set up for long distance doublehanded. *Dancer* has just finished a one-year refit in NZ. New Betamarine 60, new 16hp DC generator. Email: sv_dancer_usa@yahoo.com.

22-FT FARRIER TRAILER-TRI 680. 1987. Ventura. \$10,000/obo. Builder: Jaeger Yachts, BC, Canada. Sleeps 3 adults or 2 adults and 2 pre-teens. Used to cruise Channel Islands with family (less than 2 hours and 30 minutes - S.B. to Fry's). For more information, details and photos, email: kgarcken@pacbell.net.



COMMISSION AN OIL PAINTING OF YOUR VESSEL

There is truly no finer gift than one from the heart. Reasonable prices.

Any size on canvas. Just need photos for reference.

www.chriswalshartist.com • pittss2b2003@yahoo.com • (510) 402-9220

Going Somewhere?

Mexico ≈ Caribbean ≈ South Pacific

Stop by our office and take a bundle of *Latitude 38* magazines along with you. We promise you'll be a hero for sharing them with other cruisers!

Latitude 38 • 15 Locust Ave • Mill Valley, CA • (415) 383-8200 • Open M-F 9-5

Guide to Navigation & Tourism in French Polynesia

Best Fr Poly guide but out of print. We imported all remaining copies from authors. Excellent aerial photos of many anchorage entrances; great chartlets. \$69 plus shipping. Email: frpolytraveler@yahoo.com

YOGA FOR SAILORS ON THE SAN RAFAEL WATERFRONT

Perfect for beginners and those seeking to balance strenuous activity with gentle stretching, rest and recovery. Small group classes Tues/Thurs and private sessions. (415) 785-4530, www.bowyoga.com.

Bow Yoga



34-FT GEMINI 105 MC, 2005. San Diego. \$119,000. *Pelagic* is a custom-appointed example of a full-featured Gemini. Complete electronics, custom interior, new topside and bottom paint. You won't find a better example of a 105Mc. (619) 892-5003 or lmurphy@cox.net.

47-FT CATAMARAN HARD TOP, 2006. St. Martins. \$60,000. This is a 1/6th ownership. Price includes: Malibu II 2-person kayak Pro-XL, fishing gear, windsurfer, cockpit cushions, upgraded JVC AM/FM with CD player, Bose marine speakers, inverter, generator, folding props, custom fitted blinds in salon and electric heads and LP barbecue. Manufacturer: Robertson and Caine, fuel: diesel, number of engines: 2, hull number: RAC47063J504. Galley: 1 sink, 4-burner stove, microwave oven, refrigeration. The moorings 4700 is set up with a modern galley, 4 spacious cabins with in-suite heads. Will be launched by Nov. 15, 2014. Call (702) 525-8520 or (702) 293-2436 or email rocko.graziano@gmail.com.



34-FT CONTOUR TRIMARAN, 2000. Ventura, CA. \$88,750. *Orange* is a speedy adventure platform in excellent condition. Beautiful interior, fresh electronics, Yanmar 20 with Sail Drive, custom dodger and bimini. Many photos and details available at: www.contour34.com. Please contact me at (415) 602-5880 or email Paul@PierpontPerformanceSailing.com.



35-FT FOUNTAINE PAJOT TOBAGO. 1997. Richmond, CA. \$139,500. A good sailing cat with panoramic views in a 3-cabin layout that is rarely found on the market! Twin Yanmar diesels low hours, roller furling, lazy jacks, autopilot, windlass and super clean inside and out! All lines led aft and well suited for offshore passages. Must sell for health reasons. For more pictures and info go to: <http://db.tt/jPk023zW>. Contact: (510) 253-5883 or tobago35cat@gmail.com.



POWER & HOUSEBOATS

TWO ROOMY FIBERGLASS. Motor yachts, Sausalito berths. 50-ft International Offshore (\$48,000/obo) w/Perkins diesels in standup engine rooms and 17.5-ft beam, 35-ft remodeled Chris-Craft Catalina (\$21,000/obo). Cruise/floating office/liveaboard (with approval). Finance, lease option, or trade. (415) 888-3856 or rogercperry@gmail.com.



50-FT EX-US NAVY LIBERTY. Conversion, 1944. Monterey Marina, Monterey, CA. Best offer over \$30,000. Tri-cabin liveaboard trawler. Double V-berth, head, and shower. Spacious lower helm/galley with inside ladder to flybridge. Aft cabin/salon/bedroom. Flybridge with large sun deck. Dual Capilano hydraulic steering. Stand-up engine room. Detroit 671 diesel Morse controls. LectraSan, 35 gal holding. New 50 amp shorepower and main battery panels. Comfortable large 6' high cabins. Tastefully decorated. Walk-around deck. Slip transfers with sale. Some project work required. Owner will finance OAC. Please contact: (831) 373-6061 or johna@arnoldassoc.com.



45-FT SEA RANGER, 1984. Sausalito. \$79,900. Fully equipped spacious trawler with full-width owner's stateroom, 2 guest cabins, 2 heads w/stall showers. Newly enclosed canvas/isinglass aft saloon. New water heater and holding tank. Newly refurbished including Dish service w/2 flat screens, sound system, all electronics, generator, twin Volvo Penta diesels and radar. Call (925) 353-5750 or email at kconnolly113@gmail.com.



32-FT GRAND BANKS CLASSIC, 1977. Sausalito. \$62,900. With steady/staysail. 1977 fiberglass with many upgrades. Shows care by long time owner with mostly new everything. Only FG hull in SF Bay currently for sale. Have full specs and October 2014 survey from Wedlock. Email for pics and specs. (415) 710-3161 or lunasea2@yahoo.com.



PARTNERSHIPS

MORGAN 382 PARTNERSHIP. Sausalito Yacht Harbor. Fully equipped for SF Bay and coastal cruising. History of meticulous professional maintenance. Solid well-run partnership of five experienced owners. Adequate budget, plenty of boat availability on turnkey basis. LLC status and workable partnership agreement. Reliable Perkins 50 diesel. Radar, VHF, stereo, refrigerator, sleeps 5. Constant upgrading including standing rigging. Financials available. Prime berth, parking included. \$400/mo plus equity share negotiable. Contact: (415) 669-1963 or kjmanuel@gmail.com.

46 FT BENETEAU - NONEQUITY. Brisbane Marina. \$300. 1/8 time non-equity partnership (300\$/month)-1/4 share \$500. \$2000 refundable deposit-covers deductible on insurance, etc. All costs included. See more at www.youtube.com/watch?v=005zrB0qDqI. Contact (415) 645-3753 or (415) 494-5116 or aiumi@me.com.

CRUISING SAILBOAT PARTNERSHIP. San Francisco. Join us in starting a 4-party partnership to buy an immaculate (used) go-anywhere 40 to 48-ft cruising monohull or catamaran (still deciding which). More information at: <http://sfsail.wordpress.com>.

GEMINI 105M CATAMARAN. Southern California. Equity partnership, fantastic cruising cat, closest marina to Catalina, professionally maintained, fully equipped, fast, fun, and easy to sail. Ideal for family. Photos and equipment list available. For more information contact: (323) 487-9440 or email: Kanaloacharters@gmail.com.



SOUTH OF THE BORDER

PROFESSIONAL DELIVERY CAPTAINS. San Diego-based, USCG Master 100 GT. Sail and power. ASA-certified instructional deliveries. Pacific Mexico and Baja Bash specialists. More information at website: www.boatdeliverycaptain.org. Contact David at: (619) 913-7834 or send an email: davidhbrotherton@yahoo.com.



SAIL SHARE IN THE SEA OF CORTEZ. Marina Real/Puerto Escondido. Best offer. 40-ft sloop in Bristol condition. 2 double berths, 2 heads, all amenities (TV, stereo, Sirius) and safety equipment. Learn to sail, winter getaway (in slip), honeymoon, fishing, diving, sailing, exploring, adventure or swim with the whale sharks? Bare or crewed (USCG licensed). Will deliver to Baja fully provisioned. Terms flexible. Phone: (831) 818-8452 or (831) 688-2911 ext.104, or email: malpraclaw@aol.com or calmeismal@aol.com.



PLAN YOUR MEXICAN GETAWAY NOW. At the brand-new, gorgeous Cielo Y Mar condos. Located in Punta Mita, 35 minutes from Puerto Vallarta, available to rent from private owner. On the beach, 10 feet from the water, they offer spectacular views of ocean and mountains, the biggest infinity pool in the area, an endless beach, great surf breaks, great fishing, tremendous views of whales, bird life and the islands. While uncrowded and tranquil, just a five-minute walk to several waterfront restaurants. Choose from a spacious, beautifully furnished one- or three-bedroom unit, or an amazing two-story penthouse with lovely shade trellis on the top floor. See details at website: www.puntamitabeachfrontcondos.com. To reserve, call Dona de Mallorca: (415) 599-5012.

WANTED

GOT OLD SAILS? West Coast. I am looking for used sails: mains, jibs and spinners, for an eco-friendly project. Help me keep them out of landfills (and your garage) and give them new life. Pickup provided. Contact: (253) 350-9889 or email: jeffwapner@gmail.com.

AEROGEN/GIVENS HONOLULU. \$-open. Wanted: Aerogen wind generator 5 x 6's working or ?. Givens offshore liferaft ocean pack/6-man. (808) 230-6466 or aeolus99@yahoo.com.

GEAR

FURLBOOM FOR SALE. 19.5', P=47.17', E=18.75' Napa, CA. \$5,000/obo. Perfect working condition. Mainsail, gooseneck and track are included. New is \$12,500 without sail. See video at <http://youtu.be/CbwVWlrwFs>. Call (707) 339-0426. Email: camvawter@yahoo.com.

FOLDING BIKES. Two Montague 21-speed full size folding bikes w/custom bags, folding pedals, racks, \$350 ea. (206) 432 5473.

FEATHERING PROPELLER, MAXPROP. Ventura, CA. \$1,750. Max-Prop 3 blade feathering 19" x 1.25". Fits 1.25 inch shaft, adaptable up/down by an eighth inch. Factory reconditioned with 1 year transferable warranty. Cost new \$3,500 (805) 985-4532 or lanikai3@live.com.

PROPERTY SALE/RENT

WATERFRONT PROPERTY. Bethel Island. \$209,999. Two separate lots on the water with deep-water docks, several outbuildings for staging your next cruising adventure or keeping yourself busy, lots of off-street parking come with these deep lots. Home super cute 1 bedroom, 1 bathroom, grand room, office area and a fabulous stainless steel galley, con heart redwood docks. BART will be coming to the area soon. Great buy now! (925) 550-0858 or norell49@yahoo.com.



KKMI
NEW LISTING

Swan 59 (1984) "Rattler" has just completed a major refit with new teak decks, new engine, generator, winches and rigging. The shallow draft / centerboard make her perfect for cruising. She is 100% ready to go! \$595,000
Please contact Ken Keefe (415) 332-5564 ken@kkmi.com

BERTHS & SLIPS

SOUTH BEACH HARBOR BERTHS. Available for boats in the Spinnaker Sailing Charter fleet. We have berths for sailing vessels from 32- to 43-ft. The boat must be active in Spinnaker's charter fleet and be late model, in excellent condition, with the appropriate equipment. This is the perfect income opportunity for an owner to offset the costs of ownership, while berthing at the best marina in Nor-Cal. More at www.spinnaker-sailing.com. Call (415) 543-7333.

40-FT PIER 39 SLIP. San Francisco. \$12,000. Dock D-13, Excellent location, only 3 or 4 slips from the Harbormaster. Priced to sell. Ronald: (213) 622-5033.

50-FT BERTH FOR SALE. Pier 39, SF. Best offer. Slip J16 at San Francisco's Pier 39. Contact: (408) 954-1000 or email: office@pestanaprops.com.

50-FT PRIME SLIP. Pier 39, SF. \$50,000. F-Dock, Slip 11, east side. Protected from wind. Close to gangway, showers and marina office. Covered parking across street with special rates for owners. (559) 355-6572 or scorch@tempest-edge.com.

CREW

EXPERIENCED SAILOR. Seeking female crew. Long Beach, CA. Heading south on December 1 (+/-). 45-ft well-found sailboat. Have crossed Atlantic, sailed Mexico and Hawaii (3). Neither romance nor boat slave a prerequisite. Age not important, but must be fit and non-smoker, and adventurous and somewhat secure financially. Will cruise down to Panama, and beyond, no set schedule, no set itinerary. Come as long as it's fun. I am older, very fit and easygoing. We can meet in SF or Long Beach. (760) 482-8172.

OFFSHORE INSTRUCTION. John and Amanda Neal provide documented ocean passagemaking instruction aboard *Mahina Tiare III*, their Hallberg-Rassy 46, drawing on their combined 584,000 miles and 73 years experience. More info at www.mahina.com. Call (360) 378-6131.

TRYING TO LOCATE

LOOKING FOR JOHN HARDS. Want to regain contact with John Hards of the Beneteau 36 *Pelican*. Last known location was Nuevo Vallarta. (775) 972-0583 or rocco649@charter.net.

JOBS WANTED

PART-TIME CAPTAIN USCG MASTER. 50 GT with tow, looking for interesting part-time work on the water in Bay Area. Retired successful businessman, mid-50s, with great people skills. Contact Michael Long at (707) 483-0191 or email: michael@longfinancial.net.

JOB OPPORTUNITIES

OFFICE SERVICE PERSON. Opening for a position for office service person for yacht dealership. Must have full computer skills, time management skills and service scheduling skills. Email resume. Call: (415) 690-9923 or butch@passageyachts.com.

MARINE MASTER. Certified Mechanic. San Francisco Boatworks is seeking a Marine Master Certified Mechanic with outdrive, outboard, engine repairs in gas and diesel engines, electrical, fuel injection experience. Must have certification in Volvo or Mercury. Candidate must be self-motivated, organized and detailed, manage time efficiently and must work with minimum supervision. Must have own tools. Benefits: PTO, 401k, Medical and Dental, AFLAC. Living outside of San Francisco? Negotiable relocation fees. Please contact: (415) 626-3275 or email: aris@sboatworks.com

PASSAGE YACHTS INC. Employment opportunity, San Francisco Bay Area. We are adding a position for an experienced sales professional to join our progressive and growing Yacht Dealership Company. Company support, leads and an excellent work environment are offered. High-income sales professionals with extensive training and your income needs are six figures, we invite you to apply. Commission position. Please contact us by phone or by sending a resume to: (510) 236-2633 or butch@passageyachts.com.

COMPLETE BOAT SERVICE. Technician skills needed are diagnostic. Repair skills for mainly Beneteau and Lagoon sailboats and Beneteau powerboats. Good working environment and steady hours, a full-time position. Email resume to Butch or call with questions or for information. (415) 690-9923 or butch@passageyachts.com.

SAILING INSTRUCTORS. Nationally recognized as one of the country's top sailing schools, OCSC Sailing is looking for instructors to join its award-winning team. OCSC's rigorous curriculum is famous for turning out the best new sailors. You will enjoy thorough training to develop your skills as an instructor. Read what being an instructor at OCSC is like on our website: www.ocscsailing.com/about/people/sailing_instructor.php. Email resume and cover letter to Steve Saul, Head of Instruction, steve@ocsc.com.

BUSINESS OPPORTUNITIES

WANTED IN SAN FRANCISCO. We're looking to place a new Jeanneau 379 into our Timeshare Sailing Program. Includes South Beach Harbor berth, all maintenance, insurance, diving...everything. We can pay 100% of your owner's expenses. TimeShare Sailing. Call (415) 543-7333

LET US PAY FOR YOUR BOAT! San Francisco. 30-40 foot sailboat for our corporate charter programs. Must be in great condition. South Beach Harbor berth included! Spinnaker Sailing. Call (415) 543-7333.

FOR SALE

PDQ ALTAIR CATAMARAN



"Better than New"

- New engines
- New rigging
- New sails
- New autopilot
- New deck hardware
- New GPS plotter
- New VHF
- New AIS
- New Jordon drogue
- New bottom paint and more.....

A Steal for \$120,000



(510) 865-2511
www.helmsyacht.com
helmz@aol.com



THE BOY SCOUTS NEED YOUR BOAT



DONATE YOUR VESSEL

Your charitable donation will have a direct, positive impact on the lives of our local Scouts and local volunteer leaders.

Through the Boy Scouts of America, Scouts learn valuable boating, first aid and lifesaving skills. You can help the Scouts continue the tradition of loyalty, honesty, integrity, respect and courage.

- **STOP** Maintenance Costs
- **STOP** Slip Fees

Relieve the financial burden of your boat while helping the Boy Scouts!!

We are ready to act today!

The Boy Scouts of America...Making a difference in the lives of young men for more than 100 years.



BOY SCOUTS OF AMERICA
SAN DIEGO-IMPERIAL COUNCIL

*The Boy Scouts will
take care of all
the paperwork for you.*

**Call for more information:
619-298-6121**

Or e-mail:
Amber Green
amber.green@scouting.org

ADVERTISERS' INDEX

AB Marine 12	Brisbane Marina 43	Emeryville Marina 89	Heritage Marine Insurance 43	Marchal Sailmakers..... 116
Alpenglow Marine Lights..... 119	City Yachts 7	Equipment Parts Sales 103	Heritage Yacht Sales 129	Marina Bay Yacht Harbor 30
American Battery 119	Club Nautique 8	Far East Sails 93	Hood Sails 13	Marina Cortez..... 20
Aqua Marine..... 116	Conch Charters 101	Farallone Yacht Sales 9	Hotwire Enterprises 93	Marina de La Paz 114
BVI Yacht Charters 102	Costa Baja Resort & Marina 35	First Watch Marine..... 117	Hydrovane 117	Marina El Cid..... 48
Baja Ha-Ha Sponsors 77-79	Cover Craft 54	Flying Cloud Yachts 129	Intercoastal Financial Group 20	Marina Vallarta 30
Bay Marine Boatworks.. 27	Coyote Point Marina 39	Fortman Marina 32	Iverson's Design 40	Marine Lube 103
Bay Marine Diesel..... 99	Cruising Yachts 11	Gentry's Kona Marina 93	JK3 Nautical Enterprises 19	Marine Outboard Company..... 6
Berkeley Marine Center 49	Davis Instruments..... 43	Gianola Canvas Products..... 41	KKMI - Boatyard 132	Mariners General Insurance 41
Blue Pelican 119	Defender Industries..... 48	Grand Marina 2	KKMI - Brokerage..... 126	Maritime Institute..... 50
Blue Water Yacht Insurance 99	DeWitt Studio 99	Hansen Rigging 42	Kissinger Canvas 39	Marotta Yachts..... 130
Boat Yard at Grand Marina, The 23	Doyle Sails..... 33	Helms Yacht & Ship Brokers 126	List Marine Enterprises 44	Mathiesen Marine..... 119
BottomSiders 103	Dr. LED 40	Helmut's Marine Service 93	Loch Lomond Marina 51	McDermott Costa Insurance 102
Boy Scouts San Diego..... 127	Easom Racing & Rigging..... 45		Makela Boatworks 103	Minney's Yacht Surplus 99

CONTINUED

			
58' ALDEN YAWL, '31 \$195,000	55' HALLMAN SLOOP, '82 \$135,000	51' JEANNEAU, '94 \$149,000	50' GULFSTAR, '78 \$75,000
			
45' CORONADO, '74 \$49,500	38' ERICSON, '87 \$57,000	38' HANS CHRISTIAN 38T, '87 \$97,600	PENDING 38' BENETEAU, '91 (Moorings) \$35,000
			
36' C&C, '81 \$35,000	35' C&C SLOOP, '84 \$39,600	32' DREADNAUGHT, '73 \$35,500	30' NONSUCH, '80 \$45,000

2021 Alaska Packer Pl., Grand Marina, Alameda, CA 94501
sales@newerayachts.com • newerayachts@sbcglobal.net
(510) 523-5988 • www.newerayachts.com

ADVERTISERS' INDEX – cont'd

Modern Sailing School & Club..... 118	Owl Harbor Marina47	Sail California 15	Spaulding Wooden Boat Center..... 18	Wedlock, Ramsay & Whiting Marine Surveyors..... 99
Napa Valley Marina38	Oyster Cove Marina.....55	Sail Warehouse, The .. 118	Spectra Watermakers..... 115	West Coast Multihulls ...31
Nelson Cap, The/ Camwraps47	Pacific Crest Canvas.....24	Sailrite Kits 14	Starbuck Canvas.....46	West Marine - Rigging ..28
New Era Yachts 128	Pacific Offshore Rigging.....51	Sal's Inflatable Services.....55	Start Line Strategies.... 116	Westwind Precision Details25
New Found Metals.....44	Pacific Rigging.....54	San Francisco Boat Show.....21	Stem to Stern50	Whale Point Marine Supply36
Norpac Yachts..... 131	Pacific Yacht Imports..... 16	San Francisco Boat Works.....93	Sterling Associates49	Yachtfinders/Windseakers53
North Beach Marine Canvas.....25	Passage Yachts5	San Francisco Marina 10	Svensden's Boat Works..... 17	
North Direct Sails.....42	Peterson Power39	San Francisco Marina 10	Svensden's Marine26	
North Sails.....29	Pineapple Sails3	Schoonmaker Point Marina34	Swedish Marine.....52	
North Sails - Gear.....45	Punta Mita Beachfront Condos..... 119	Sea Bags53	TMM Yacht Charters...101	
O'Connell Electric46	Quickline41	Seashine55	Trident Funding4	
Oakland Yacht Club49	Raiatea Carenage Services.....88	Seatech 118	Twin Rivers Marine Insurance53	
Opequimar Marine Center52	Rainman51	South Beach Harbor22	Vallejo Marina.....92	
Outboard Motor Shop47	Richardson Bay Marina45	South Beach Riggers.....25	Ventura Harbor Boatyard..... 114	
	Rubicon Yachts37		weatherguy.com 117	





MEMBER
BoatWizard
M.L.S.
YACHTWORLD.COM

Flying Cloud Yachts



6400 Marina Drive
Long Beach, CA 90803

Sail • BROKERS • Power
www.flyingcloudyachts.net
flyingcloud@verizon.net

Phone (562) 594-9716
Fax (562) 594-0710



55' BRUCE ROBERTS, '76 \$209,000



50' VALIANT, '02 \$539,500 \$529,000



48' CELESTIAL KETCH, '85 \$145,000



46' HILLER SPINDRIFT, '84 \$148,500



43' YOUNG SUN CC, '84 \$129,900



40' VALIANT CUTTER, '78 \$79,900



40' MAYFLOWER KETCH, '61 \$399,000



39' JEANNEAU O'DAY, '83 \$55,000



37' ELITE, '84 \$44,900



37' TAYANA CUTTER RIG, '79 \$79,000



37' NAUTOR SWAN, '80 \$89,900



36' ISLANDER, '74 \$40,000

APPROX. 100 LISTINGS ON OUR WEB SITE: www.flyingcloudyachts.net

HERITAGE
Yacht Sales

Live your Dreams



DEALERS
FOR CATALINA
AND HUNTER
SAILBOATS

Long Beach-Naples
Newport Beach
San Diego
San Pedro
Wilmington

866-569-2248
877-389-2248
760-402-3868
310-549-2248
310-547-8007

www.heritageyachts.com



49' Transpac CC, '76 \$169,000



48' C&C Landfall, '80 \$178,000



45' Hunter CC, '09 \$249,900



43' J/130, '94 \$189,900



43' Jeanneau DS, '06 \$219,000



42' Catalina, '93 \$89,900



41' Beneteau 411, '00 \$139,500



40' Saga 409, '06 \$209,900



36' Moody CC, '81 \$44,900



35' Catalina, '04 \$119,900



34' Catalina MkII, '07 \$99,000



32' Hunter Vision, '89 \$29,900



Marotta Yachts of Sausalito

Brokers of Fine Sail and Motor Yachts

415-331-6200 • info@marottayachts.com • www.marottayachts.com

See at: www.marottayachts.com



48' TAYANA CUTTER Deck salon version of Robert Perry's 'go-to' design for safe, luxurious passage making. This low time, late model example is BRISTOL and TURNKEY. **\$419,000**

See at: www.marottayachts.com



46' KELSALL CATAMARAN, 2008 Easy to handle long-distance cruiser, bristol in and out. Twin Volvo diesels, Northern Lights genset, full electronics, lying in Sausalito YH. **\$324,000**

See at: www.marottayachts.com



50' BREWER-DESIGNED KETCH, 1989 Bullet proof, steel-hulled, cutter-rigged, full keel with cut away forefoot and skeg hung rudder, 5kW Northern Lights genset. **\$179,000**

See at: www.marottayachts.com



41' KIRIE FEELING SLOOP, 1996 Spacious accommodations with a cabin skylight and great sailing in typical SF conditions. Starfinder is a great example of a great design. **\$134,000**

See at: www.marottayachts.com



42' PT PERFORMANCE TRAWLER, 1986 Cockpit motoryacht. Really nice, heavily built trawler with twin diesels, shows bristol inside and out. **\$109,000**

See at: www.marottayachts.com



43' HUNTER 430, 1995 In nice shape inside and out. Spacious, well laid-out 3-stateroom/2-head interior with 6'6" headroom and lots of light and storage. Lying Oxnard. **\$97,000**

See at: www.marottayachts.com



41' SCEPTRE, 1987 Substantially built cruiser with inside steering station, Leisure Furl in-boom main, Yanmar diesel. Priced WAY below market. Call for details. **\$94,000**

See at: www.marottayachts.com



31' PACIFIC SEACRAFT, 1988 Designed and built by actual cruisers. Shows very nicely. Yanmar diesel, radar, chartplotter, autopilot, offshore dodger, wheel, roller furling. **\$78,000**

See at: www.marottayachts.com



44' FELLOWS & STEWART, 1946 Repowered beauty owned by professional shipwright and maintained at Sausalito's Arques Shipyard many years. Shows bristol inside and out. **\$69,000**

See at: www.marottayachts.com



45' HUNTER, 1987 Amazing space below with 6'7" headroom; feels like a 50+ footer! Boat is in nice shape, well equipped and well priced. Pullman berth forward, shoal draft. **\$59,500**

See at: www.marottayachts.com

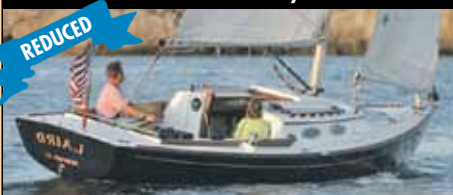

28' ALERION EXPRESS, 2000 Lovely little daysailer shows as new for a fraction of the price. Very well equipped; potentially transferable Sausalito Yacht Harbor slip. **\$52,000**

See at: www.marottayachts.com



36' ISLANDER, 1979 One of the nicest Islanders we've seen in years, this boat has been extensively updated inside and out and is a MUST SEE! **\$49,000**

See at: www.marottayachts.com



35' MAXI 105, 1983 High quality Swedish-built yacht with a 3/4 aft cockpit configuration. In excellent condition, she shows much newer than her actual age. **\$49,000**

See at: www.marottayachts.com



37' CHOATE, 1976
Nice example of very successful IOR racer/cruiser. **\$29,000**

See at: www.marottayachts.com



31' HUNTER, 1987
Clean and well priced. Would make a good, inexpensive, fun daysailer or weekender. **\$19,000**

at 100 BAY STREET • SAUSALITO • CALIFORNIA 94965 since 1946

NORPAC YACHTS

1150 Brickyard Cove Rd., B9, Pt. Richmond, CA 94801

(510) 232-7200 • FAX (510) 232-7202

email: info@norpacyachts.com

**BUY HERE,
SELL HERE,
BE
HAPPY!**



RED BEAUTY!
38' ERICSON One-owner, red-hulled beauty has been yacht club kept & properly equipped w/120% self-furling jib, full battened main, 75% storm jib, asym. spinn. w/pole, 2-speed self tailers, lines led aft, MORE! Asking **\$49,500**



36' ISLANDER FREEPORT

Perry's brilliant medium-sized cruiser. Diesel, full galley, wheel, enclosed head with shower. Great lines and beautiful down below. With their big keel and skeg-hung rudder, these boats sail very well. +++ Asking **\$39,950**



36' CHEOY LEE Beautiful. Traditional. This design is known for its beauty & sailing qualities. Here's your opportunity to own a nice one. Glass hull, varnished teak cabins. Low-hr Yanmar dsl, dodger, RF, SSB, Monitor, wheel, spinnaker, dinghy w/2 outboards, more! Asking **\$28,500**



57' CHINESE JUNK Twin Gardner dsls. Roomy, comfortable, unique & ideal for liveaboard. Just hauled & much upgrading/refit completed. 3 strms, large salon & galley, genset, wood carvings, great wheelhouse observation salon, high quality construction, ++. Asking **\$119,900**

Thanks to the boating community for another great year doing what we like with the people we like!
Happy Holidays and Have a Super 2015!



40' BRITISH COLUMBIA CLASSIC TROLLER Beautiful pleasure yacht conversion. Ultimate in seaworthiness, economy & saltiness. Built for rigors of commercial use in PNW waters & all conditions. 6-71 GM dsl, 8KW dsl gen, inverter, red cedar planking, nav computer, radar, depth, 2 VHF's, AP, reefers/freezer, dsl range, +. Asking **\$29,950**



120' CHARTER/EXCURSION VESSEL. Legal for 12 paying passengers plus crew. Stand-alone high-endurance bluewater steel vessel. V-12 CAT, gensets, comfort, seaworthiness, safety and great accommodations, crane, HELICOPTER PAD and MORE! Alaska anyone? Asking **\$360,000/offers**



175' LIGHTHOUSE TENDER, "FIR" Designated National Historic Landmark by U.S. Dept. of the Interior. STEEL, twin diesel-powered small ship, fully operational and in great condition. Beautiful, comfortable interior, great accommodations and more. Asking **\$360,000/offers**



39' CAL Very nice one. Diesel rebuilt by British Marine. Rig overhauled 2013 incl. new standing/running rigging, new batteries/charger, CNG range w/oven, 6'5" hdrm, sleeps 8. New VHF, AIS, new radar, GPS, VHF, depth. Lines led aft. Cabin heater, cockpit table, wheel, dodger, MORE. Asking **\$59,950**



32' HUNTER VISION Hunter's much copied and highly successful breakthrough design in outstanding condition. Unstayed mast, lines led aft for shorthanded sailing, dodger, wheel, dsl, GPS, AP, radar on an arch. Great roomy layout & MORE. **Must see!** Asking **\$39,900**



34' PETERSON Sloop. Doug Peterson's renowned Performance Cruiser design. Great boat. Well cared for and nice above & below. Yanmar dsl, roller furling, 3 spinn, 2 mains, 5 jibs, new batteries, full galley w/reefer/freezer, 6'6" hdrm, AP, more! Asking **\$19,900**



33' SPAULDING Sloop. Beautiful bright red performance cruiser by Sausalito's legendary Myron Spaulding. Epoxy saturated Brunzeel cold-molded construction. Excellent condition. Monel, bronze, +. Low hrs i/b Greymarine, teak decks, 2 mains, 2 genys & spinnaker. Asking **\$12,950**



37' RAFIKI Meet the Ha-Ha in Mexico. Yanmar 50 hp dsl, radar, A/P & vane, SSB, dodger. Lines led aft. Forced air dsl heat, large enclosed head & stall shower. Cruiser keel, fridge & MORE! A comfortable cruiser w/lots of storage & amenities. Asking **\$49,500**



38' ERICSON Sloop. Great Bruce King design. Diesel, roller furl, self-tending winches, dodger, full galley w/fridge & freezer, radar, GPS, plot, etc. with repeaters, spinnaker, wheel/pedestal, solar panel, tender w/motor, AP, liferaft, 2 dbl staterooms & MORE! Asking **\$47,000**



39' GULF PILOTHOUSE Sloop/Motorsailer. Inside and outside helms, very clean, only 280 hours on diesel engine, RF, lines led aft, spinnaker, rod rigging, running rig new. Lots of other new equipment/gear. 2 double staterooms, +. Asking **\$96,500**



34' GEMINI 105 CAT Lovingly maintained example of this popular, affordable cruiser. GPS, VHF, depth, CD/stereo, battened mainsail, roller furling, lazy jacks, fixed dodger, wheel steering, h/c water, cockpit shower, enclosed maine head w/shower, full galley & MORE! Asking **\$94,950**



45' FUJI KETCH Cruise equipped, 60 hp dsl, genset, wind gen, radar/GPS/plotter and full elect with repeaters at pedestal/wheel steering, dodger, main, spinnaker, storm jib, roller furling, genoa, autopilot, reefers/freezer, more! Asking **\$99,500**



50' HERRESHOFF CENTER COCKPIT Ketch. Aft stateroom, 115hp 6-cyl dsl, full galley, AP, radar, GPS, dinghy-ro/b, more! A big, comfortable, strongly-built, GLASS, bluewater world cruiser from a fine designer, FAITH comes with a lot of gear. Asking **\$82,500**

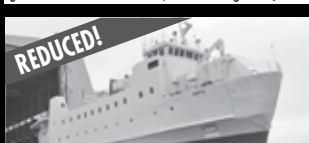

133' CAR FERRY Conversion: Office/Studio. Ultra spacious. Fully operational. Set up for very comfortable living and working. Ice Class, built in Norway. Fine condition. Absolutely unique and VERY cool. Rare opportunity. Asking **\$390,000**



41' MORGAN Center Cockpit Out Island Sloop. Diesel. Outstanding & very popular cutaway full-keel cruiser design. Live/cruise. REFINISHED in & out. Teak & holly sole. Radar, speed/log, VHF, stereo, GPS/plotter, A/P, spinn., MORE! Asking **\$44,900**



35' ISLAND PACKET Lightly used on San Francisco Bay so she's super clean/ready to cruise. Huge, comfortable cockpit w/room for everyone. Massive, well equipped galley & fantastic layout below w/roomy aft & forward cabins. Built to high standards to sail safely. Asking **\$118,500**



46' GARDEN PORPOISE Ketch. Bill Garden's magnificent all-teak world-beater design. She's circumnavigated before & ready to do it again. Fully equipped to take on the world's oceans in safety & comfort. Try **\$79,950**

PLEASE SEE www.norpacyachts.com and/or www.yachtworld.com/norpacyachts for MORE BOATS

CALL (510) 232-7200 OR TOLL FREE (877) 444-5087 OR CALL GLENN DIRECTLY AT (415) 637-1181 FOR APPOINTMENTS & INFORMATION



THANK YOU

The entire Team at KKMI would like to thank the racers, cruisers, day-sailors, fishermen and all the boaters who made up the extraordinary Class of 2014. We appreciate the opportunity to have served you and wish you a Happy New Year!

2 C's, Aaron, About Time, Absolut Getaway, Absolute, Absolute Therapy, ACE, Adagio, Adele, Aegea, Aeolian Harp, Aeolus, Affinity, Agua Azul, Airborne, Airjaldi, Akela, Akrotiri, Akula, Albacore, Alcyone, Ale Kai, Alegria, Aleta, Allora, Almar, Alpha III, Altair, American Eagle, Amilia, Amor Del Mar, Amore, Amphianda, Anakalia, Anchor's Up, Andale, Anduril, Angelina, Ani Kai, Ann, Anna, Annabelle, Annie, Another Girl, Anthea, Apollonia, Apples, Apropos, Apsara, Aquamarine, Aquavit, Arabella, Arbitrage, Arendal, Arendel, Argo, Argus, Ariadne, Ariele, Arione, Artemis, Arugula, Astenia, Astrid, Audacity, Auriah, Aurora, Aurora III, Ava Serene, Avalon, Avanti, Avatay, Aventura, Azure, Azurro, BAADS, Bacala, Back Bay, Baidin, Bandit, Bandito, Banshee, Bantham, Bantry, Barbara J, Barbary Ghost, Bay Bird, Bay Dream, Bay Move, Bay Voyager, BeeCom, Bella Bleu, Bella Jean, Bella Sirena, Betelgeuse, Big Bird, Bittersweet, Black Diamond, Black Mallard, Black Trih, Blackhawk, Blade, Bliss, Blithe Spirit, Bloody Sunday, Blow Fish, Blue, Blue Fin, Blue Heron, Blue Pearl, Blue Star, Blue Steel, Blue Yonder, Bluewater, Bluzzz, Bob, Boire au Soleil, Bolero, Bonacia, Bonne Idee, Boreal, Bottle Rocket, Bound to Please, Break Away, Breez'n, Briana K, Brigadoon, Bright Hour, Brundall, Buddies, Buenos Aires, Built For Comfort, Buona Fortuna, Cadence, Calamaddy, Caledonian, California, Calinda, Camelot, Can Can, Cantius, Cape Ommaney, Capet, Carioca, Caro, Carodon, Caroline, Carolyn Kay, Carquinez Coot, Caspian, Catalyst, Catch 22, CC & Water, Ce Ce's Rival, C'est Fou, Cetacea, Chances Are, Charge, Charisma, Charlie D, Charlie Noble, Cheers, Chinook, Chiquita 2.0, Chorus, Christa Kay, Christabel, Ciao Bella, Cima, Cipangu, Clam, Clio, Close Quarters, Cloud, Cloud 9, Cloud Nine, Coast Guard Vessel, Coconut Express, Condor II, Confetti, Constellation, Courage, Crackers, Credit, Criminal Mischief, Crystal Phoenix, Cuckoo, Cuckoo's Nest, Curlew, Cuvee II, Czechmate, Daddy's Girl, Danae, Dance Away, Daring, Dash, Dauntless, Dawn, Debbie Marie, Defiance, Delphinus, Dent Relief, Deo Volente, Desert Storm, Destiny, Dharma, Diana, Ditz, Diversion, Doghouse, Don Miguel, Donna Marie, Don't Panic, Dos Amigos, Double Happiness, Double Trouble, Double Wide, Dr. Quality V, Dragonfly, Dream, Dream Catcher, Dry Martini, Dutch Canal Boat, E Ticket, Eagle Rae, Easy Going, Eau Claire, Eclipse, Eden, El Dorado, El Nido, Elan, Elise, Elixir, Elli, Emerald Sea, Emotional Rescue, Empress, En Garde, Encore, Endless Summer, Endorfin, Enfant Terrible, Enterprise, Entheos, Epiphany, Escapade, Escape, Esperanza, Estate Master, Estrella, Event Horizon, Expeditious, Expression, Fable, Fandango, Fast Friends, Faster Horses, Fat Chance, Fearless, Felicity, Fellwalker, Fenton, Fever, Fifth Star, Final Final II, Finally Enough, Fishore, Fitzroy, Flash Gordon, Fledgling, Flibertigibbet, Flojito, Flora M, Fly by Night, Flyer, Fog City, Fog Horn, Fogdog, Foil, Folksong, Follow You Follow Me, Footloose, Force Majeur, Forever Amber, Fortuna, Forty Love, Fox Sea, Free Water, Freedom, FreedomSong, Frequent Flyer, Freyja, Fundango, Galaxsea, Gali, Gambit, Gamine, Ganessa, Gardylloo, Gaviota, Genevieve, Gentle Storm II, Geronimo, Gettin' Lucky, Giorno Libre, Gjente, Glory, Glory Bound, Godot, Gold Coast, Golden Moon, Goliard II, Golley, Gone Platinum, Good Timin', Gracia, Grainedo, Grand Cru II, Grand Fromage, Great Britain, Green Buffalo, Green Erickson, Grey Ghost, Grey Goose, Grizabella, GT Style, Guesthouse, Gulfstream, Gusto, Haley's Comet, Hamachi, Hana Pau, Hanger One, Hansel, Happy Talk, Harpoon, Haru, Hauraki, Hazardous Waste, Helen Ruth, Helgoland, Heron, Hey Jude, High Five, Higher Hopes, Holm Port, Honukai, Horizon, Hudson Street, Hula Girl, Hurricane, Huska, Idyll Ways, Imi Loa, Inca, Infinity, Insatiable, Insolet Mix, Inspired Environments, Integrity, Intertide, Invisible Hand, Ione, Ippachi, Irish Ayes, Irish Rose, Isla Mia, Island Girl, Island Mist, Itajime, Itinerant, It's All Good, Jakatan, Jalan Jalan, Jam Session, Jamani, Jambalaya, Janae, Jani Lee, Jarlen, Javelin, Jewel, Jitterbug, Jocelyn, Joie de Vivre, Joka, Josephine Two, Journey, Jubilee, JuJu, Junoesque Jones, Kabrum, Kahwara 2, Kailey Rane, Kanigo, Katar, Kat's Meow, Kauehi, Kells, Kestrel, King Richard, KingFish, Kingman Photography, Kiwi Cat, Knot Inn, Kota, Kristina, Kuleana, Kydonakis, La Bonbonniere, La Cancha, La Dolce Vita, La Dolce Vita IV, La Vida, Lady E, Lady Hawke, Lasers, Lauren Kate, Lauren Marie, Lazy Lady, Legacy, Leonore, Leopard, Levitation, Liberty, Light Touch, Light Wave, Lightning, Lightspeed, Lilith, Linda Noelle, Linnea, Lionheart, Liquidity, Little Friend of all the World, Little Lara, LittleTomThumb, Loafer's Glory, Lohengrin, Lucia Eluca, Lucy Jane, Luna C, Madmen, Mae West, Magic Window, Maguro, Mahal, Mahalo Makani, Maid of Time, Majestic, Majestic Lady, Malia, Mallord, Mandy Jane, Manu Kai, Many Horses, Mara, Marara, Marbella, Maree, Margo, Maria Elena, Mariah, Martinique, Maryanna, Marylee, Masae, Maserati, Matador, Matsu, Mayhem M3, McKFirm, Me Gusta, Meanie, Meditrrina, Melissa Jo, Menbihan, Mental, Mephisto Cat, Mercury, Merrily Ann, Mia Tane, Michi, Midori, Migration, Migrator, Mil Besos, Milagro, Minervois, Mirage, Miss G, Miss Hailey, Miss Peggy, Mission City, Mistral, Mojo II, Moon Dragon, Moon Mist, Moon Shadow, Moondancer, Moonshine, Moonstruck, Mooragami, Moretorise, Morning Star, Motorcycle Irene, Moxie, Mr. George, Mucho Loco, Muffin, Muirin, Murano, Mutara Nebula, My Rest Office, My Sarita, Mykonos, Nadja Delphine, Naiad, Nain, Nataraja, Natoma, Nauti Bouy, Nauti Cat, Nauty Bouy, Need a Name, Nehemiah, Neptune's Car, Nettie, Neutral Buoyancy, Neverland, New Day, New Easy Rider, New Rules, New Sea Angler, New Seeker, Nice N Easy, Nimbus, Nomad, Noregreta, North Star, Northern Lights, Notre Isle, Nouverania, Nova, Novocita, Number One, O' Susanna, Oasis, Obsession, Ocean Gale, Ocean View, Odd Job, Odyssey, Ohlone, Old Pulteney, Oliver Twist, On Delay, One Hundred, One Trick Pony, Optimus Prime, Oriole, Orion, Osa, Oso le mio, Osprey, Our Destiny, Our Medication, Outer Limits, Outrage, Ozma, Pachanga, Pacific Coaster, Pacific Star, Pakele, Pangaea, Papa Bill, Paradise, Paradise Ali, Paradox, Pasadera, Patience, Patita, Pax, Pax Water, Peerless, Pelican, Pelorus Jack, Peregrine, Perseverance, Phoebe, Phoenix, Picaroon, Pillar Point, Pilot, Pinocchio, Pinot Noir, Pintail, Pistachio, Plenty, Plouf, Plus Sixteen, Pneum Addict, Polly, Praire Oyster, Pretty Lady, Prezzo, Primitime, Princess, Principessa, Pristine, Protector, Pruffrock, Puffin, Pura Vida, Purity, Q, QE 3, Questuary, Quicksilver, Quixote, Racer X, Radio Flyer, Ragtime, Rainbow, Rantum Scantum, Rascal, Rebecca, Recidivist, Redeemed, Redhead, Reel Time, Regulus, Relentless, Releta, Remedy, Respite, Restless, Retreat, Reunited, Rhapsody, Rhumline, Ripple, Robin, Rochambeau, Rock & Roll, Roebot, Rose Noire 4, Rosella, Rubicon, Ruckus, Rustler, Sadie K, Safari, Sahar, Sailfish, Sailor Dog, Sally B II, Salsipuedes, Salt Shaker, Sam, Samba Pa Ti, Sanary-sur-Mer, Sandman, Sandra Marie, Sandy II, Sans Souci, Santana, Santorini, Sarabi, Satin Doll, Scarlet Runner, Scarperer, Scoma's, Scoots, Sea Banshee, Sea Beast, Sea Changes, Sea Farmer, Sea Fever, Sea Fox, Sea Jay, Sea Lion II, Sea Nile, Sea Pac, Sea Ray-der, Sea Star, Sea Ya, Seacure, Seahorse, Seas The Day, Seastainable, Second Opportunity, Seeker, Sense, Sensei, Sequel, Serena, Serendipity II, Serenisea II, Serenity, SF Joe, Shadow, Shady Grady Lady, Shalom, Shangra La, Sharona, Sherrie Lynn, Shoo Fly, Show Biz, Sidonia, Sijambo, Silver Cloud, Silver Dawn, Silver Fox, Silver Wind, Silverheels II, Sim Querida, Simcha, Sirene, Sirocco, Skai, Ski Sanger, Skian Dhu, Sky High, Sleeper, Slip Away, Slow Dance, Smart Recruiters, Smooth Jazz, Sno Globe, Solace, Solano Country, Solla Sollew, Sonata, Sorte', Sparrow, Special Lady, Spirit, Sprig, Sputnik, SRPD Rescue 22, Star Quest, Starbright, Stella, Stephany Jean, Stowe Away, Strider, Struntje Light, Sugar Magnolia, Summerwind, Sun Song II, Sundance, Sunquest, Sunrise, Sunshine, Surf Scooter, Suriana, Swan, Swazik, Sweet And Salty, Sweet Okole, Swerija, Sydney Marie, Tabi, Tahitiienne, Tahu Le'a, Tai One On, Take Five, Take Me With You, Talisman, Tandem, Tangled up in Blue, Temblor, Temerarious, Tempress, Tenacious, Tender to Sunrise, Tequa, The Dark Side, The Easy Way, The Egret, The Galen Diana, The Lovely Martha, The Possionier, Thirsty, Three Graces, Tiama, Ticket II, Tiger, Tigger, Time Out, Time Warp, Timeline, Tincup, Tinka, Tom Cat, Tomboy, Tootsie, Top Kat, Topzy Turvy, Tortuga, Touch and Go, Trailer, Tranquility, Transfusion, Trianalise, Trilogy, Triple Crown, Truant, True Colors, Try Baby Tri, Tsonokwis, Tudo Bien, Twin Vee, Two Drifters, Two Truths, Tyche, Zigane, Uncle Wiggly, Unity, USA 76, Uta II, Utmost, V Twelve, Valhalla, Valkyrie, Vallejo Ferry, Vamanos, Vanguard, Vanishing Animal, Varua, Vector, Velocita, Venture, Verona, Vesla, Vesper, Vested Interest, Victory, Viewfinder, Viking Princess, VIP, Vision, Vitesse, Vitrum, Vivace, Volant, Voyager, Wai'ula'ula, Walk On, Walking on Water, West'n Away, Water Music, Westwind, Whirled Peas, White Knight, White Pelican, White Wing, Wicked, Wicked Sister, Widgeon, Willanina, Wind Dancer, Wind Trip 8, Wind Witch, Windfall, Windsong, Windswept, Windwalker, Windward, Windward Star, Wisperm, Wit's End, Wizard, Wooden Coronado, X Buoy, X-Capade, Xtasea, Yare, Zamazaan, Zapato Verde, Zephyr, Zeus and last but not least Zinfu.