

Latitude 38

VOLUME 426 December 2012

WE GO WHERE THE WIND BLOWS

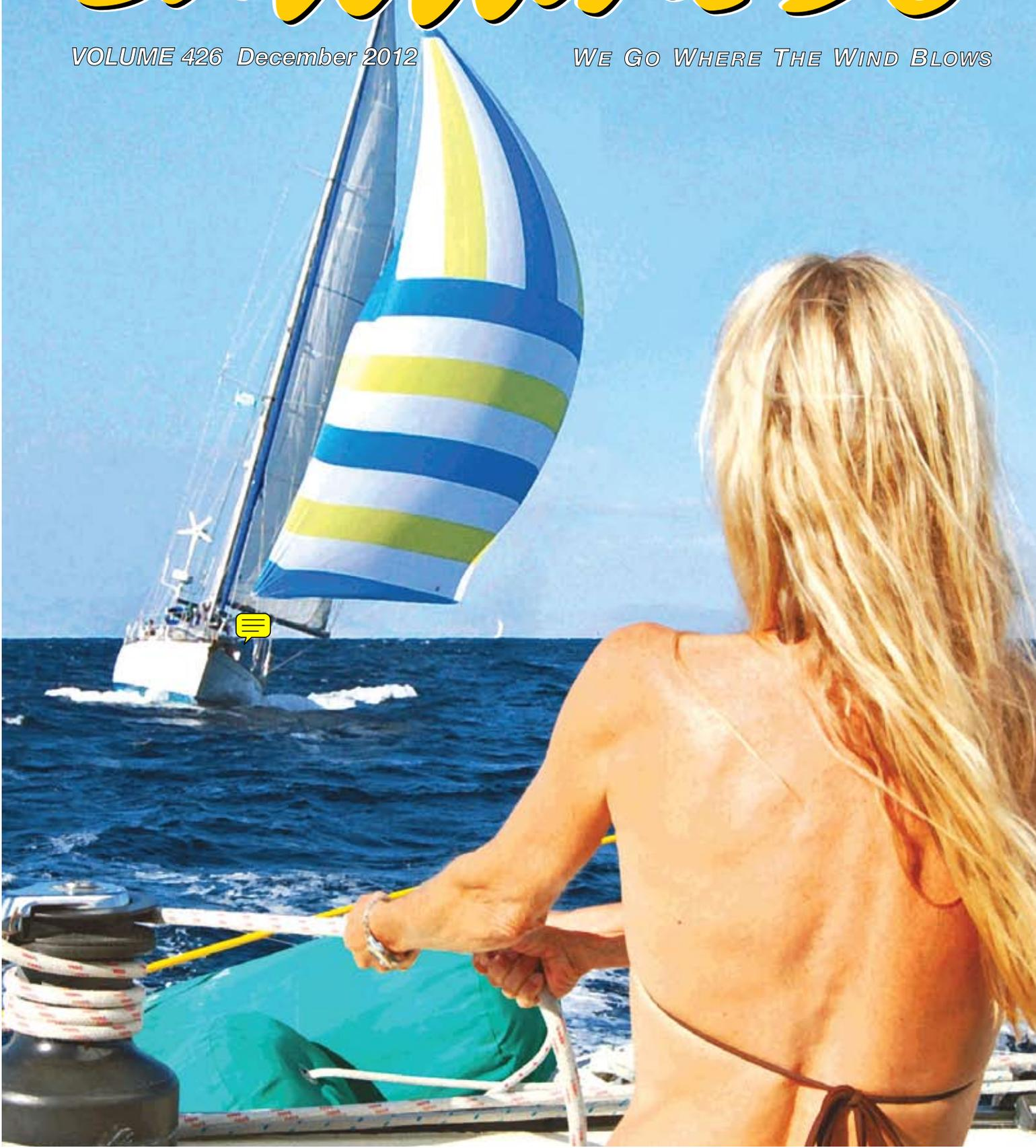

Latitude 38

DECEMBER 2012

VOLUME 426



Warm Holiday Wishes from the Crew at Grand Marina

- Prime deep water double-fingered concrete slips from 30' to 100'
- Great Estuary location in the heart of beautiful Alameda Island
- Complete bathroom and shower facility, heated and tiled
- FREE pump out station open 24/7
- Full Service Marine Center and haul out facility
- Free parking
- Free WiFi on site!
- And much more...

DIRECTORY of GRAND MARINA TENANTS

Blue Pelican Marine.....	138
Boat Yard at Grand Marina, The ..	24
Marchal Sailmakers	139
New Era Yachts	144
Pacific Crest Canvas.....	14
Alameda Marine Metal Fabrication	
Pacific Yacht Imports	
UK-Halsey Sailmakers	



GRAND MARINA
ANDERSON-ENCINAL

510-865-1200

Leasing Office Open Daily
2099 Grand Street, Alameda, CA 94501
www.grandmarina.com

We Approve This Message

★
Happy
Holidays
from all of us
at Pineapple Sails.
We'll be closed from
Sat., Dec. 22, through
Tues., Jan. 1.

PHOTO ERIK SIMONSON/WWW.PRESSURE-DROP.US



*Shameless**

Each fall the Yacht Racing Association of San Francisco Bay schedules a Champion of Champions regatta. Called the Yankee Cup, it pits the winners of each YRA division against all the other season's winners.

The fleet is split into two groups, according to each boat's PHRF rating. This year the trophy for PHRF 2 was awarded to *Shameless*, George Ellison's Schumacher 30.

George is happy with *Shameless's* success and happy to share it, giving credit where credit is due: to Carl Schumacher for designing a great boat, to his steady crew for their skills and commitment, and to Kame Richards of Pineapple Sails for designing and building sails that match the boat, the racing goals and the budget.

We at Pineapple Sails are proud of our reputation as the go-to sailmaker for real personal attention and quality sails. And we'll claim bragging rights. Shamelessly.

Give us a call.

YOUR DEALER FOR: Musto foul weather gear, Dubarry footwear and Headfoil 2

Sails in need of repair may be dropped off at:
West Marine in Oakland, Alameda, or Richmond.

*Powered by Pineapples



PINEAPPLE SAILS

Phone (510) 522-2200

Fax (510) 522-7700

www.pineapplesails.com

2526 Blanding Ave., Alameda, California 94501

BOAT LOANS

from



Trident Funding

*"a fresh
approach
from people
you can trust"*

In Northern California call
JOAN BURLEIGH
(800) 690-7770

In Southern California call
JEFF LONG
(888) 883-8634

www.tridentfunding.com

CONTENTS

subscriptions	6
calendar	8
letters	14
sightings	62
baja ha-ha recap	76
webb chiles interview	88
season champs, pt. I	92
passin' through	98
max ebb: a shore thing	102
the racing sheet	106
world of chartering	112
changes in latitudes	116
classy classifieds	132
advertisers' index	141
brokerage	141

Cover: Harry Hazzard's Idylle 15.50 *Distant Drum* threatens to pass the committee boat *Profligate* during last month's Baja Ha-Ha Rally.

Photo: Latitude 38/Andy

Copyright 2012 Latitude 38 Publishing, LLC

Latitude 38 welcomes editorial contributions in the form of stories, anecdotes, photographs – anything but poems, please; we gotta draw the line somewhere. Articles with the best chance at publication must 1) pertain to a West Coast or universal sailing audience, 2) be accompanied by a variety of pertinent, in-focus digital images (preferable) or color or black and white prints with identification of all boats, situations and people therein; and 3) be legible. These days, we prefer to receive both text and photos electronically, but if you send by mail, anything you want back must be accompanied by a self-addressed, stamped envelope. **Submissions not accompanied by an SASE will not be returned.** We also advise that you not send original photographs or negatives unless we specifically request them; copies will work just fine. Notification time varies with our workload, but generally runs four to six weeks. Please don't contact us before then by phone or mail. Send all submissions to editorial@latitude38.com, or mail to Latitude 38 editorial department, 15 Locust Ave., Mill Valley, CA 94941. For more specific information, request writers' guidelines from the above address or see www.latitude38.com/writers.html.

SUPER VALUES!



Jeanneau Sun Odyssey 45, 2007
\$290,000



Beneteau 381, 1999 \$89,000



Island Packet 380, 1999 Galatea
\$227,000

SAIL

51'	Beneteau Cyclades	2006	\$235,000
50'	Gulfstar	1977	139,500
46'	Beneteau Oceanis 461	1998	174,000
45'	Jeanneau Sun Odyssey	2007	290,000
42'	Beneteau First 42	1985	89,500
41'	Tartan 4100	2004	345,000
41'	Dehler DS	1998	159,000
40'	Beneteau	2009	199,000
40'	Beneteau	2008	175,000
40'	Beneteau 40.7	2001	165,000
39'	Beneteau 393	2003	134,500
38'	Beneteau 381	1999	89,000
38'	Island Packet 380	1999	199,000
38'	Island Packet 380	1999	227,000
38'	Beneteau Moorings	1991	42,000
38'	Ericson 38-200	1988	68,000
37'	Island Packet 370 cutter	2004	269,900
37'	Pacific Seacraft yawl	1984	119,000
36'	Hunter sloop	2004	94,500
36'	Beneteau 361	2000	89,900
36'	Catalina	1989	49,900
36'	Pearson 36-II	1985	57,900
34'	C&B Marine Tiffany Jayne	1982	29,000
33'	Beneteau 331	2004	89,300
33'	Hunter 33.5 sloop	1992	39,500
32'	Beneteau 323	2007	93,500
32'	Beneteau 323	2007	89,500
32'	J/32	1997	79,000
32'	Freedom	1984	47,500
32'	West sail	1976	64,400
31'	Island Packet	1988	55,000
28'	Alerion Express	2002	74,500
24'	Corsair Sprint 750	2008	55,000

POWER

61'	Mikelson SFPH	2002	990,000
58'	Offshore Pilothouse	1995	795,000
53'	Navigator CPMY	1998	249,000

2 Bay Area Offices
List with Us for Results

1220 Brickyard Cove Rd
Pt. Richmond, CA
(510) 236-2633
www.passageyachts.com

Perfect Stocking Stuffers from Beneteau and Passage Yachts
Northern California's Exclusive Beneteau Sail & Power Dealer

2013 BENETEAU SAIL



BENETEAU OCEANIS 45



BENETEAU OCEANIS 41



BENETEAU OCEANIS 37

2013 BENETEAU POWER



BARRACUDA 9

Perfect for Commuting and Fishing



SWIFT TRAWLER 34

Perfect Companion to Your Sailboat

**New Arrival of 2013
Beneteau Sail and Power
at our docks
ready for delivery**

Inquire About Our Smarter Yacht Program Charter Placement Services with More!

- More choices of locations – East or West Coast Placements
- Programs that fulfill IRS requirements for full tax deductions
- Club member only chartering options keep your yacht looking like new while earning money
- Multiple revenue programs – full charter or fractional
- Exclusive Beneteau Sail or Power Placements

OPEN BOAT WEEKEND in ALAMEDA ■ December 8-9



1070 Marina Village Pkwy
Suite #101
Alameda, CA
(510) 864-3000

BENETEAU ISLAND PACKET ALERION SWIFT TRAWLER BROKERAGE

VARIPROP

Variprop is the finest automatically feathering propeller available in the world today



- Near zero sailing drag
- Powerful thrust in head seas
- Incredible control in reverse
- External and separate pitch adjustment for forward and reverse
- Greatly reduced "propwalk"
- Soft Stop™ Multidisc Brake to minimize impact when reversing blades
- 2, 3, and 4 blade models and Saildrive
- Simple, easy, one piece installation—no shaft modifications required

401-847-7960
Fax: 401-849-0631

747 Aquidneck Ave.
Middletown, RI 02842

info@varipropusa.com
www.varipropusa.com

SHAFT SHARK

*The best rope,
line and debris
cutter there is!*



401-847-7960
sales@ab-marine.com
www.ab-marine.com

Navisafe Navi Light 360°

Dinghy & Emergency Lighting from Navisafe



The new Navi Light 360° is a cost-effective, super bright LED light that is visible in darkness from up to 5nm. Its high burn time, small size, waterproof qualities and ability to float make it a convenient and cost-effective addition to any cruiser's arsenal!



401-847-7960
sales@ab-marine.com
www.ab-marine.com

SUBSCRIPTIONS

**YOU CAN ALSO GO TO
www.latitude38.com
TO PAY FOR YOUR
SUBSCRIPTION
ONLINE**

eBooks email list. *Free!*

See www.latitude38.com to download the entire magazine for free! Our eBooks are in PDF format, easy to use with Adobe Reader, and also available in Issuu format.

Email: _____

Please allow 4-6 weeks to process changes/additions, plus delivery time.

Enclosed \$36 for one year Third Class Postage (Delivery time 2-3 weeks; Postal Service will not forward third class; make address changes with us in writing.)

Enclosed \$55 for one year First Class Postage (Delivery time 2-3 days.)

Third Class Renewal First Class Renewal (*current subs. only!*)

Gift Subscription *Card to read from:* _____

NOTE: Subscriptions going to correctional facilities, FPO/APO (military), Canada, and Mexico are first class only. Sorry, no other foreign subscriptions.

Name _____

Address _____

City _____ State _____ Zip _____

Phone: () _____ Email: _____

CREDIT CARD INFORMATION
Min. Charge \$12

MASTERCARD VISA AMERICAN EXPRESS

Number: _____ Exp.: _____ csv: _____

INDIVIDUAL ISSUE ORDERS

Current issue = \$6 ea.

Back Issues = \$7 ea. MONTH/YEAR: _____

DISTRIBUTION

We have a marine-oriented business/yacht club in California which will distribute copies of *Latitude 38*. (Please fill out your name and address and mail it to the address below. Distribution will be supplied upon approval.)

Please send me further information for distribution outside California

Business Name _____ Type of Business _____

Address _____

City _____ State _____ Zip _____

County _____ Phone Number _____

Latitude 38

"we go where the wind blows"

Publisher/Exec. Editor Richard Spindler richard@latitude38.com
Associate Publisher John Arndt john@latitude38.com ext. 108
Managing Editor Andy Turpin andy@latitude38.com ext. 112
Editor LaDonna Bubak ladonna@latitude38.com ext. 109
Racing Desk racing@latitude38.com ext. 105
Contributing Editors John Riise, Paul Kamen
Advertising Sales John Arndt john@latitude38.com ext. 108
Advertising Sales Mike Zwiebach mikez@latitude38.com ext. 107
General Manager Colleen Levine colleen@latitude38.com ext. 102
Production/Web Christine Weaver chris@latitude38.com ext. 103
Production/Photos Annie Bates-Winship annie@latitude38.com ext. 106
Bookkeeping Penny Clayton penny@latitude38.com ext. 101

Directions to our office press 4
Subscriptions press 1,4
Classifieds class@latitude38.com press 1,1
Distribution distribution@latitude38.com press 1,5
Editorial editorial@latitude38.com press 1,6
Calendar calendar@latitude38.com
Other email general@latitude38.com

www.latitude38.com

15 Locust Avenue, Mill Valley, CA 94941
Ph: (415) 383-8200 Fax: (415) 383-5816





Dealer for Jeanneau, CNB & Grand Soleil Yachts
See over 100 new and used yacht listings at www.CruisingYachts.net



Call for Special

**2013 JEANNEAU 409
IN STOCK!**



**2013 JEANNEAU 469
ARRIVING SOON!**



Two Available

**2008 JEANNEAU 39i
Asking \$187,000**



**2002 HUNTER 380
New Listing \$102,500**



**2000 CATALINA 42
Listed at \$149,900**



**1991 HUNTER 42 CC
Listed at \$110,000**



**2007 CATALINA 42
Offered at \$199,900**



**2005 HUNTER 41DS
Reduced \$172,000**



**2000 MOODY 42CC
Reduced \$189,500**



**1979 MARAMU 46
Asking \$159,800**



**2005 JEANNEAU 49
Offered at \$269,000**



**2008 HUNTER 45 CC
Reduced \$259,000**



**2006 BENETEAU 57
Offered at \$699,000**



**2001 CATALINA 36
Listed at \$99,000**

California's largest used yacht broker with 5 waterfront locations.

**San Diego
(619) 681-0633**

**Alameda
(510) 521-1327**

**Marina del Rey
(310) 822-9400**

**Newport Beach
(949) 650-7245**

**Oxnard
(805) 791-2082**



IF YOU'RE HERE, "THERE" IS PROBABLY RIGHT AROUND THE CORNER.

The world's largest boating supply retailer, a full service grocery store and a choice of fine dining are all within walking distance of Sausalito's only full-service harbor. Not to mention the only fuel dock in the area and ample parking for your car. All overseen by a friendly staff.

To find out more, give us a call at 415 332 3500 or visit our website for more details.

 **CLIPPER**
YACHT HARBOR
www.clipperyacht.com

 **CLIPPER**
YACHT HARBOR
310 HARBOR DRIVE

CALENDAR

Non-Race

Dec. 1 — 36th Annual Lighted Yacht Parade on the Oakland/Alameda Estuary. Starts at 5:30 p.m. Presented by Encinal YC, Oakland YC and Marina Village Yacht Harbor. This year's theme is 'Lights, Camera, Action'. Find out more and enter your boat at www.lightedyachtparade.com.

Dec. 1 — South Beach YC Lighted Boat Parade along the South Beach shoreline, 6 p.m. Dinner and hot ruddered bum at the YC after. Info, www.southbeachyc.org.

Dec. 1 — Vallejo YC Harbor Lighted Boat Parade. Info, www.vyc.org or (707) 643-1254.

Dec. 1 — Stockton SC Lighted Boat Parade. Info, www.stocktonsc.org.

Dec. 1 — Santa Cruz YC Lighted Boat Parade in the south harbor, 5:30 p.m. Info, www.scyc.org.

Dec. 1-18 — *Hawaiian Chieftain* docks in Sacramento until 12/6, then moves to Antioch. For dates, times and details on tours or booking passage, see www.historicalseaport.org.

Dec. 2 — Monterey Peninsula YC Lighted Boat Parade, 5:30 p.m. Info, www.mpyc.org.

Dec. 2 — Subasta Auction at Marina de La Paz, 9 a.m.-4 p.m. This fundraiser for needy kids in La Paz is hosted by Fundación Ayuda Niños La Paz (FANLAP) and sponsored by Club Cruceros. Info, www.FanlapSubasta.com.

Dec. 2-30 — Free sailing at Pier 40 every Sunday courtesy of BAADS. Info, (415) 281-0212 or www.baads.org.

Dec. 5, 12 — Wednesday Yachting Luncheon Series at St. Francis YC, 12-2 p.m. Enjoy lunch and a dynamic speaker each Wednesday for about \$25. All YCs' members welcome. More info under the 'Events' tab at www.stfyc.com.

Dec. 8 — Holiday celebrations at Hyde St. Pier with live music, activities and a visit from the Big Guy himself, 3-4:45 p.m. Kids under 16 free, adults \$5. Tour historic vessels from 6-9 p.m. Free, RSVP required. Info, (415) 447-5000.

Dec. 8 — Sausalito Lighted Yacht Parade along the waterfront, 6 p.m. Info, www.sausalitoyachtclub.org.



LATITUDE / LADONNA

Lighted yacht parades are a wonderful excuse for a winter outing. Just be sure to pack warm clothes and warming libations.

Dec. 8 — Petaluma YC Lighted Boat Parade, 6 p.m. Info, www.petalumayachtclub.com.

Dec. 9 — Hanukkah begins at sundown.

Dec. 14 — St. Francis YC Lighted Boat Parade, from Pier 39 to Ft. Mason, 6 p.m. Info, www.stfyc.com.

Dec. 21 — Summer Sailstice for those in the southern hemisphere. It's still six months away for the rest of us.

Dec. 22 — San Rafael Lighted Boat Parade, 5:30 p.m. Info, www.marinyachtclub.com.

Dec. 25 — Shop our online chandlery for the perfect gift for your favorite sailor. Go to www.latitude38.com and be sure to order by 12/14 for delivery in time for Christmas.

FARALLONE YACHT SALES



The all-new Ranger 31 makes her way from Alameda for a test sail.



We're the proud dealer of Ranger Trailerable Tugs and Catalina and Tartan Sailing Yachts – all Made in America brands. Please visit www.faralloneyachts.com for details.

Happy Holidays from the crew at Farallone!

OPEN BOAT WEEKEND DECEMBER 8-9 ~ BOATS ARE SELLING ~ LIST WITH US!



2000 Catalina 310 Taravana \$74,900



1966 CHEOY LEE 66 OCEAN TRAWLER Soproessa \$449,999



1991 OCEAN ALEXANDER Morningstar \$165,000

Preowned Catalina Yachts at Our Docks

Catalina 470, 2005	\$327,000
Catalina 470, 1999	MOTIVATED SELLER! 170,000
Catalina Morgan 440, 2006	SOLD!
Catalina 42 MkII, 2004	195,000
Catalina 42, 1989	MOTIVATED SELLER! 89,000
Catalina 400, 2004	SOLD!
Catalina 400, 2001	REDUCED! 168,000
Catalina 380, 2000	134,900
Catalina Morgan 38, 1994	SOLD!
Catalina 36 MkII, 2001	98,500
Catalina 36, 1999	REDUCED! 82,500
Catalina 36, 1995	75,000
Catalina 36, 1984	49,500
Catalina 36, 1983	REDUCED! 51,900
Catalina 350, 2005	129,900

Catalina 350, 2003	116,500
Catalina 34, 2003	95,000
Catalina 34, 1990	47,500
Catalina 34, 1987	49,000
Catalina 34, 1989	47,500
Catalina 320, 2000	SOLD!
Catalina 310, 2000	REDUCED! 74,900
Catalina 310, 2000	59,000
Catalina 30, 1988	34,000
Catalina 30, 1984	22,000

Preowned Sailing Yachts at Our Docks

Gulfstar 50 owners' model, 1978	125,000
Beneteau 473, 2006	288,500
Norseman 447, 1984	199,000
Tartan 4100, 2004	345,000
C&C 38, 1979	41,000
Tayana 37 Cutter	77,000

Hunter 37, 1987	49,000
Hunter 356, 2003	REDUCED! 84,995
Santa Cruz 33, 1978	35,000
Hunter 31, 2007	REDUCED! 69,500

New Ranger Tugs (base price)

Ranger 31 Tug, 2013	NEW MODEL YEAR! 279,937
Ranger 29 Tug, 2013	NEW MODEL YEAR! 229,937
Ranger 27 Tug, 2012	159,937
Ranger 21EC Tug, 2011	49,937

Preowned Ranger Tugs at Our Docks

Ranger 29 Tug, 2010	NEW LISTING! 189,900
Ranger 25SC Tug, 2010, incl. trailer	REDUCED! 120,000
Ranger 25 Tug, 2008	120,000
Ranger 21EC Tug, 2009	47,500
Ranger 21EC Tug, 2009	44,000

Preowned Power Yachts

Cheoy Lee 66 Ocean Trawler, 1987	REDUCED! 449,999
Ocean Alexander 44	165,000



1070 Marina Village Pkwy
Alameda, CA 94501
(510) 523-6730

2801 West Coast Hwy
Newport Beach, CA 92663
(949) 610-7190

From San Diego, CA
Call
(619) 523-6730

NEW WYLIECAT 40



Safe, fun, fast.
Race, cruise, or charter.



bemark YACHTS

BROKERAGE BOATS

Islander 4-Cabin	53	1979
Jeanneau DS	42	2008
Morgan 416 CC Ketch	41	1981
Island Packet SP Cruiser	41	2007
Passport	40	1987
Wyliecat	40	2013
Wylie	39	1985
Cascade	36	1981
Hanse 350	35	2008
Sea Ray Sundancer	34	2001
Bristol 31.1	31	1983
Wyliecat	30	2013
Willard Cutter	30	1976
Herreshoff Ketch, a "10"	30	1962

Charter the Wyliecat 65 Derek M. Baylis
for all the great 2013 events. Book now!

310 Harbor Drive, 2nd Floor, Sausalito, CA
415/332/6585

Larry R. Mayne, broker B-02871
John Saul, bemarkyachts@gmail.com

CALENDAR

Dec. 28 — Sail under the full moon on a Friday.

Jan. 1 — Clear away last night's cobwebs with a daysail.

Jan. 1 — 'Round the Island circumnavigation of Alameda. Starts at Island YC, then on to Aeolian and Ballena Bay YCs, finishing at Encinal YC. Info, IslandYCEvents@yahoo.com.

Jan. 9-13 — 53rd Annual Portland Boat Show at the Expo Center. Info, www.otshows.com.

Jan. 24-27 — San Diego Sunroad Boat Show at Sunroad Resort Marina on the east end of Harbor Island. Info, www.bigbayboatshow.com.

Jan. 25-Feb. 3 — Seattle Boat Show Indoors + Afloat at CenturyLink Field & South Lake Union. The largest boat show on the West Coast. Info, www.seattleboatshow.com.

Racing

Dec. 1 — Fall #7. SSC, www.stocktonsc.org.

Dec. 1 — Perry Cup/Midwinter. MPYC, www.mpyc.org.

Dec. 12-14 — Banderas Bay Blast & Pirates for Pupils Spinnaker Run. Info, www.vallartayachtclub.org.

Dec. 15 — Fall #8. SSC, www.stocktonsc.org.

Dec. 30 — Christmas Race. MPYC, www.mpyc.org.

Jan. 1 — Master Mariners New Year's Day Race and Chili Potluck at Pt. San Pablo YC in Pt. Richmond. Info, (415) 364-1656 or www.mastermariners.org.

Jan 20-25 — 26th Annual Key West Race Week by Quantum. Info, www.premiere-racing.com.

Jan. 26 — Three Bridge Fiasco, one of the oddest and most entertaining races ever invented, and the first SSS event of the season. Info, www.sfbaysss.org.

Midwinter Regattas

BERKELEY YC — Midwinters: 12/8-9, 1/12-13, 2/9-10. Bobbi, (925) 939-9885 or bobbi@jfcbat.com.

BERKELEY YC — Chowder Races: Sundays through March except when it conflicts with above.

CAL SAILING CLUB — Year-round Sunday morning dinghy races, intracub only, typically in Laser Bahias and JY15s. Info, racing_chair@cal-sailing.org.

CORINTHIAN YC — Midwinters: 1/19-20, 2/16-17. Michael, racing@cyc.org.

ENCINAL YC — Jack Frost Series: 1/19, 2/16, 3/16. Info, rearcommodore@encinal.org.

GOLDEN GATE YC — Manuel Fagundes Seaweed Soup Series: 12/1, 1/5, 2/2, 3/2. Info, (916) 215-4566 or raceoff-vice@ggyc.com.

ISLAND YC — Estuary Midwinters: 12/9, 1/13, 2/10, 3/10. John, (510) 521-2980 or iycracing@yahoo.com.

OAKLAND YC — Sunday Brunch Series: 1/6, 1/20, 2/3, 2/17, 3/3. Jim, oyracecom@gmail.com or (510) 277-4676.

REGATTAPRO — Winter One Design & IRC: 12/8, 1/12, 2/9. Jeff, (415) 595-8364 or jzarwell@regattapro.com.

RICHMOND YC — Small Boat Midwinters: 12/2, 1/6, 2/3, 3/3. Opti Midwinters: 12/1, 1/5, 2/2, 3/2. Bob, bbranstad@gmail.com.

SANTA CRUZ YC — Midwinters: 12/15, 1/19, 2/16, 3/16. Info, (831) 425-0690. Laser Midwinters: 12/9, 1/13, 2/10, 3/10. Rob, robschuyler@cruzio.com.

SANTA ROSA SC — Winter Series: 12/2. Info, www.santarosasailingclub.org.

SAUSALITO YC — Sunday Midwinters: 12/2, 1/6, 2/3, 3/3. Dave Borton, (415) 302-7084 or race@sausalito-yachtclub.org.

SEQUOIA YC — Winter Series: 12/1, 1/26, 2/9, 3/16. Redwood Cup: 12/16, 1/13, 2/3, 3/3. Info, www.sequoiayc.org.

SOUTH BEACH YC — Island Fever Midwinters: 12/15,

Cityyachts



San Francisco's Yacht Broker

43 Years of Experience and Knowledge



42' Catalina 42-3, 1989
\$97,000



40' Hinckley Bermuda
MkII CB, 1968
\$119,000



40' Farr, 1992
50-ft S.F. Berth



40' Caliber 40 LRC, 1998
\$189,500



39' Cal MkII, 1979
\$49,000



37' Tayana Cutter, 1977
\$59,000



37' Hallberg-Rassy
Center Cockpit, 2006
\$309,000



36' Catalina, 1986
\$45,000



32' Westsail, 1977
\$49,000



30' Nonsuch Ultra, 1989
\$69,800



30' Cape Dory Cutter, 1982
\$39,500



30' Albin Ballad, 1978
\$25,000



33' Nauticat, 1987
\$79,995



41' Storebro SRC 400, 1990
\$169,000
Call about SF Giants special



39' Sea Ray 390, 1985
\$195,000



34' Legacy, 2003
\$270,000

10 MARINA BLVD., SAN FRANCISCO, CA 94123 • Toll Free: 877-444-5091 • 415-567-8880
FAX (415) 567-6725 • email: sales@citysf.com • website: www.citysf.com

PLEASE VISIT OUR FUEL DOCK AT GASHOUSE COVE MARINA • OPEN 7 DAYS A WEEK • 9AM TO 5PM

NEW J/70



Step up to a new level of performance with a J/Boat.

J/111



Come see the J/70 and J/111, plus a fantastic selection of brokerage boats on our docks at Marina Village Yacht Harbor in Alameda.

SAIL California

www.sailcal.com

Alameda
(510) 523-8500
norman@sailcal.com
steve@sailcal.com
teri@sailcal.com
rod@sailcal.com

CALENDAR

1/19, 2/16, 3/16. Info, www.southbeachyc.org.

TIBURON YC—Midwinters: 1/12, 2/9, 3/9. Ian, race@tyc.org.

VALLEJO YC—Tiny Robbins Midwinters: 12/1, 1/5, 2/2, 3/2. Info, www.vyc.org or (707) 643-1254.

Please send your calendar items by the 10th of the month to calendar@latitude38.com. If you're totally old-school, mail them to *Latitude 38* (Attn: Calendar), 15 Locust Avenue, Mill Valley, CA, 94941 or fax them to us at (415) 383-5816. But please, no phone-ins! Calendar listings are for marine-related events that either are free or don't cost much to attend. The Calendar is not meant to support commercial enterprises.

December Weekend Tides

date/day	time/ht. HIGH	time/ht. LOW	time/ht. HIGH	time/ht. LOW
12/01Sat	0158/4.6	0626/3.1	1214/5.6	1905/-0.3
12/02Sun	0237/4.6	0710/3.2	1254/5.4	1942/-0.2
12/08Sat	0643/5.9	1320/0.8	1945/4.0	
	LOW	HIGH	LOW	HIGH
12/09Sun	0042/1.9	0726/6.3	1411/0.0	2058/4.2
	HIGH	LOW	HIGH	LOW
12/15Sat	0126/5.3	0608/2.5	1216/6.7	1857/-1.4
12/16Sun	0213/5.4	0709/2.5	1309/6.2	1945/-0.9
	LOW	HIGH	LOW	HIGH
12/22Sat	0011/2.1	0656/5.9	1356/0.6	2037/4.0
12/23Sun	0107/2.4	0737/6.0	1443/0.2	2139/4.2
12/24Mon	0200/2.7	0817/6.0	1524/-0.1	2229/4.4
12/25Tue	0248/2.8	0855/6.1	1600/-0.3	2312/4.6
	HIGH	LOW	HIGH	LOW
12/29Sat	0055/4.8	0528/2.9	1120/6.0	1808/-0.5
12/30Sun	0127/4.9	0607/2.9	1158/5.8	1840/-0.4
12/31Mon	0158/5.0	0648/2.8	1238/5.6	1913/-0.2

December Weekend Currents

date/day	slack	max	slack	max
12/01Sat		0002/3.2F	0332	0536/1.9E
	0846	1135/2.0F	1414	1742/4.3E
	2139			
12/02Sun		0040/3.2F	0414	0620/2.0E
	0931	1219/1.9F	1455	1826/4.1E
	2218			
12/08Sat	0209	0518/3.0F	0826	1128/4.0E
	1529	1815/2.8F	2126	2350/2.6E
12/09Sun	0303	0609/3.0F	0910	1221/4.6E
	1621	1915/3.3F	2232	
12/15Sat	0304	0518/2.7E	0828	1119/3.1F
	1408	1728/5.5E	2124	
12/16Sun		0028/4.3F	0352	0610/2.8E
	0929	1215/2.9F	1505	1819/5.0E
	2214			
12/22Sat	0240	0544/2.6F	0836	1151/3.6E
	1553	1900/2.7F	2149	
12/23Sun		0016/1.8E	0333	0633/2.4F
	0921	1240/3.8E	1643	1952/3.0F
	2248			
12/24Mon		0113/1.7E	0423	0718/2.4F
	1004	1323/4.1E	1728	2038/3.2F
	2339			
12/25Tue		0159/1.7E	0508	0759/2.4F
	1045	1403/4.3E	1809	2120/3.3F
12/29Sat	0224	0431/2.1E	0744	1032/2.4F
	1317	1637/4.6E	2036	2335/3.4F
12/30Sun	0301	0511/2.2E	0824	1112/2.3F
	1356	1718/4.4E	2109	
12/31Mon		0009/3.4F	0338	0553/2.4E
	0908	1156/2.2F	1437	1800/4.2E
	2143			

SAIL *California*

POWER UP WITH SAIL CALIFORNIA

ALAMEDA

1070 Marina Village Pkwy #108
Alameda, CA 94501
(510) 523-8500
FAX (510) 522-0641

SEATTLE

SAIL NORTHWEST
7001 Seaview Ave. NW #140
Seattle, WA 98117
(206) 286-1004



J/44, 1991, Phantom
Well equipped, race or cruise.
Asking **\$239,000**



J/111, 2011, Invisible Hand
Ready for Transpac 2013!
Asking **\$319,000**



Bakewell-White 50, 2002, Brisa
Custom design built for world
cruising. Asking **\$615,000**



Tayana 55, 1988, Samadhi V
Many recent upgrades.
Asking **\$249,000**



Luhrs 32 Open, 2003 Mad Dash
Clean, well maintained, great price.
\$114,900



True North 38, 2002, Ricochet
This SUV of the sea is read
for fun on the water.
\$184,900



Columbia 30 Sportboat, 2006
Escudero
Lift keel. On trailer. Race ready.
Asking **\$89,800**



Pacific Seacraft 40, 1999
DreamKeeper
Must see, beautifully maintained
classic cruising boat. Asking **\$314,900**



C&C Landfall 48, 1981, Footloose
Total refit, ready to go anywhere
in the world! Asking **\$159,995**



J/120, 2002, Alchera
Don't miss this incredible deal! This
boat is well equipped and beautifully
maintained. **\$169,000**



J/105s
We have 4 from
\$68,500



Aerodyne 38, 2003, Kira
Versatile boat. Daysail, cruise? This
is your boat. Asking **\$189,000**

55' Tayana CC, '88, <i>Samadhi V</i>	\$249,000	40' Farr, '97, <i>Far Niente</i>	\$170,000	34' J/34, '85, <i>The Zoo</i> *.....	\$29,900
52' Santa Cruz 52, '99, <i>Renegade</i>	\$495,000	40' Pacific Seacraft, '99, <i>DreamKeeper</i>	\$314,900	34' MJM 34z, '05*.....	\$259,000
52' TransPac w/IRC mods, '03, <i>Braveheart</i> *.....	\$395,000	39' Silverton 351 Sedan Cruiser, '99.....	Pending \$99,995	33' Synergy 1000, '99.....	\$59,000
50' Bakewell-White, '02, <i>Brisa</i>	\$615,000	39' Carroll Marine CM 1200, '95*.....	\$55,000	33' Back Cove, '08.....	SOLD
48' J/145, Hull #9, '03*.....	\$675,000	38' True North 38, 2002, <i>Ricochet</i>	\$184,900	32' Catalina 320, '95*.....	\$52,000
48' C&C Landfall 48, '81, <i>Footloose</i>	\$159,995	38' Aerodyne 38, '03, <i>Kira</i>	\$189,000	30' Columbia 30, '06, <i>Escudero</i>	\$89,800
48' 1D48, '96, <i>Chaya</i>	\$60,000	38' Alerion, '07*.....	\$269,000	30' J/30, '79*.....	\$26,000
47' Valiant, '81, <i>Sunchase</i>	SOLD	36' J/109, '03*.....	\$189,000	30' Peterson Half Ton*.....	\$14,900
45' Jeanneau Sun Odyssey, '08*.....	\$319,000	36' J/36, <i>Dawn's Early Light</i>	SOLD	30' Scout 30, '80, <i>Zelda</i>	\$54,500
44' J/44, '90, <i>Phantom</i>	\$239,000	35' J/105, '92, <i>Vim</i>	\$75,000	29' MJM 29z, '07*.....	\$269,000
43' J/130, '96*.....	\$184,000	35' J/105, '02, Hull #581, <i>Business Time</i>	SOLD	28' J/28, '87*.....	\$32,000
42' Beneteau 423, '07*.....	\$204,500	35' J/105, '01, Hull #400, <i>Lulu</i>	\$105,000	28' Alerion Express, '02*.....	\$59,500
41' J/124, '06.....	SOLD	35' J/105, '00, Hull #355, <i>Whisper</i>	\$89,000	26' J/80, '06, <i>J Hawk</i>	\$48,500
40' J/120, '02, <i>Alchera</i>	Reduced \$169,000	35' J/105, '00, Hull #347, <i>Bald Eagle</i>	SOLD	26' J/80, '01, <i>Nimbus</i>	SOLD
40' J/120, '98, <i>Jolly Mon</i>	\$165,000	35' J/105, '99, <i>Life Is Good</i> *.....	\$68,900	26' J/80, '00*.....	\$29,000
40' J/120, '94*.....	\$149,000	35' J/35C, '91*.....	\$89,000		

* Denotes Seattle Boats

SAIL *California*

www.sailcal.com

email: norman@sailcal.com, steve@sailcal.com, teri@sailcal.com, rod@sailcal.com

DEALERS FOR THESE FINE YACHTS:

Santa Cruz
— YACHTS —

SUMMIT
YACHTS

J
BOATS

Yacht owners trust

Pacific Crest Canvas

for the best in design, service and quality.

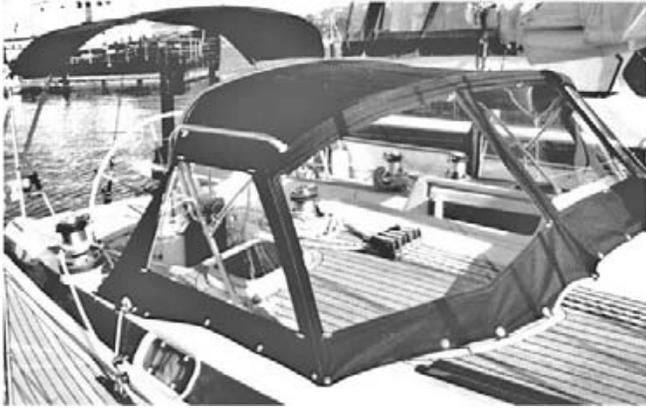

We strive to make our products the
Highest Quality at the Best Prices

Specializing in:

Baja Awnings

Lightweight and waterproof
Durable and easy to launch
Multiple side screen configurations

Coastal Dodgers

Affordable designs
High quality materials
Superior workmanship

Cruiser's Awnings

Easy setup off your dodger
Flies with no bulky frame
Includes shade screens

Offshore Dodgers

Welded aft handrail
Bolt-on side handrails
Lexan windshields



www.pacificcrestcanvas.com

Located in Grand Marina Open Mon.-Fri. 8-4
2021 Alaska Packer Pl., Ste. 13 Sat. by appointment
Alameda, CA 94501 510-521-1938

LETTERS

↑↓ MEET LITTLE ALCATRAZ

Help! I read about the charter vessel *Neptune's* recently hitting a shoal in the Bay. It was described as being on "the west side of Alcatraz." I sail the Bay, but I'm not aware of such a rock. Can you help?

David Westcott
Special Lady, Ericson 34
Brickyard Cove

David — The shoal/rock is about 100 yards off the WNW tip of Alcatraz, and there is a buoy about 250 yards off the island to warn mariners. See your chart. Every couple of years a boat such as Neptune goes up on it — some even get stuck — to remind folks that it's there. Luckily nobody was injured or killed.

Can anybody think of other popular bits of Bay bottom that take Northern California sailors by surprise?

↑↓ ONE DAY TOO LATE

We read about Victor Beelik's advice to turn off one's depthsounder around whales — the ping seems to attract them — one day too late. We were sailing just outside the Gate on Saturday, November 3 when a California grey whale approached us with great curiosity — despite our best efforts to jibe away. The inquisitive creature just kept turning with us until it was



COURTESY MANU KAI

about parallel with our transom about 25 feet to starboard.

Since we sail a Hunter 41DS, and this gentle creature obviously was bigger than our boat, we were more interested in evasive maneuvers than in taking photographs.

'Manu Kai's depthsounder will now be switched off when near whales. The video I shot was much more impressive, as it helps you appreciate the true size of our visitor.

Whale encounters are no longer rare for coastal cruisers, and we've had many up and down the coast for years. But this one was a bit different, as the whale was clearly interested in us. Now we'll know to turn off the depthsounder immediately when in the vicinity of whales, so as not to confuse them unnecessarily or encourage our fond friends to visit.

Ken Mumford & Cathy Kirby
Manu Kai, Hunter 41DS
Kailua, HI / Alameda

Ken and Cathy — Based on our experience, the number and variety of whales off the coast of California and Mexico seems to have increased dramatically in the last 10 years. During this year's Ha-Ha we had another whale first: three orcas (mom, dad, and baby), which are toothed apex predators, coming very close to Profligate. Mom and the baby were about 30 feet away, while dad came within three feet of the port transom — where crewmember Mark was dumping fish guts overboard — before swimming under the cat. Mark freaked because the 'killer' whales' diet consists almost exclusively of mammals. Mark estimated the male's length to be 20 feet; de Mallorca guessed 10 feet; and Susie guessed 30 feet. Scientists report that males are generally 20 to 26 feet long.

For what it's worth, we had our depthsounder on.

↑↓ SHOCKING SELF-RIGHTEOUSNESS

I know my letter is rather late and the controversy is a bit cold. I didn't write it until I read about the sinking of the



'Tis The Season To Be Hauly!

This holiday season, give yourself the gift of expert repair service

from **Svendsen's**

Svendsen's Boat Works would like to extend our sincere thanks and good wishes to you and your family. As we go forward into the New Year, we hope to see more and more people discovering the joy of boating, from dinghy sailing to cruising to Big Boat racing – and, of course, the thrill of the Cup races in 2013!

To our customers, it has been our pleasure to serve you in 2012. If you are not yet a Svendsen's customer, bring your boat to us and see why we're the Bay Area's most trusted full-service boat yard.

Or, simply drop by our Chandlery any day of the week, and pick up a gift for the boating enthusiast in your family (especially if it's you)!



1851 Clement Avenue, Alameda CA

Boat Yard: 510.522.2886 | svendsens.com

Chandlery: 510.521.8454 | svendsensmarine.com

WINTER SPECIAL
Free Polish & Wax With Any
Svendsen's Bottom Job
Call to schedule: 510.522.2886
or schedule online: svendsens.com

Special ends
Jan. 1, 2013

Find holiday gear here!



We're geared up for the holidays with the gifts sailors really want!

You already know that nobody has more in store for your boat. And for the holidays, we have more great gifts for anyone who loves the water!

From stocking stuffers to marine stereos, find great boating gift ideas at your local West Marine store or online at westmarine.com.

Can't Decide?

Gift cards • Available online and at all store locations • westmarine.com/giftcards



West Marine[®]
For your life on the water[™]

Follow us on:   

We have 17 stores in Northern California, including our Alameda Sailing Superstore!

Visit www.westmarine.com to find the store nearest you.

LETTERS

Bounty [ed note: see *Sightings* for that story], which has inspired commentary similar to what I'm reacting to.

As I would have expected, *Latitude* hit just the right note in the September issue recap of US Sailing's Final Report on the loss of five lives and *Low Speed Chase* at the Farallon Islands. Two points:

1) How many of the skippers in that race knew the 1.3-times-the-wave-height figure for breaking waves? How many knew exactly how big the waves were that they were sailing in, and that two or three out of 257 would be expected to be of a much greater height? How many were checking their GPS when they rounded the island in order to steer a course that was far enough off to be safe according to these calculations? Maybe I'm naïve, but I can't believe it was very many.

2) I wonder how many sailors would claim that they've never had a moment when they said, "Whoa, that was close. We got away with one." If they made such a claim, whether they were racers or not, I wouldn't believe them.

I'm shocked at the amount of self-righteousness I hear from some sailors, even prominent ones, commenting on the loss of *Low Speed Chase*. We are now hearing similar opinions with regard to the sinking of the *Bounty*. As I write this, very little in the way of facts about the *Bounty* incident has been revealed, yet no less a personage than Don Street has already called the captain, who lost his life, "foolish" on *Scuttlebutt*. This stuff is so easy to say, but we should remember that some truly great sailors have died at sea, and ask if it is logical to claim we are superior to them because we managed to stay lucky. No matter how experienced a sailor you are, it takes a lot of hubris to believe you are smarter than the ocean.

Since *Latitude* requested the sailing experience of those commenting, I certainly wouldn't call myself a racer, but I have done a bit of racing around here. For example, the '99 Doublehanded Farallones on my Ericson 39, where there was a fatality and we got dismasted. I also have been around the Southeast Farallon in heavy weather when I was not racing, and will confirm that the waves on the windward side of the island can steepen up in a very intimidating way without warning. My other sailing experience includes a circumnavigation with my Ericson. I also hold a 50-ton Master's License.

Tony Johnson
Whisper, Catalina 22
San Francisco

↑↓ HF RADIO IS A GREAT TOOL

While the 180-ft replica of HMS *Bounty* was lost to Hurricane *Sandy*, it looks as if the crew used HF/SSB radio to get their distress message out. While this will be amazing to some, it is proof — again — that since HF/SSB email can routinely travel 2,000 to 5,000 miles, and has a massively redundant shore station infrastructure, when the shit hits the fan, HF/SSB email is an obvious mode to use.

I have information from Winlink that the *Bounty* was able to connect to three shore stations to pass data, with at least two of the stations outside the "affected" area of *Sandy*. This is where HF/SSB excels, and is the reason government agencies, hospitals, universities and Fortune 500 companies have installed HF with modems as an alternate path to pass email. Connecting to a shore station that is high and dry 1,000 miles from the disaster is the advantage. Satellite links are cool, but there are a limited number of connections a sat can support and, in a disaster, they get used up very quickly.

If any yacht clubs or other organizations would like more background on HF/SSB, sending data over SSB, and so on, please don't hesitate to contact me. I have done public speak-



YACHT BROKERAGE - SALES & SERVICE WWW.JK3YACHTS.COM

SOLD, SOLD, SOLD - WE ARE LOOKING FOR MORE QUALITY LISTING, CALL US TODAY !



2006 65' J/Boats J/65
MAITRI \$1,979,000



2000 46' J/Boats J/46
QUESTAR \$415,000



(2 avail) 2005 43' J/Boats J/133
PALADIN & PICANTE \$350,000



2008 41' X Yachts X-41
XPLETIVE \$285,000

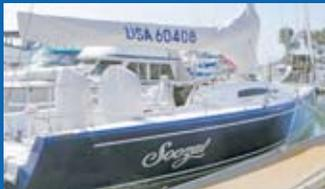

2008 40' King / Summit 40
SOOZAL \$539,000



2000 40' SABRE 402
CYGNUS \$259,000



1999 40' J Boats J/120
BLUEBIRD \$169,000



2004 36' Beneteau First 36.7
AY CALIENTE! \$118,000



2000 35' Tartan 3500
\$129,900



2) 35' J/Boats J/105
2002 KEALAIKAHIKI \$89,900
2003 LUCKY STAR \$109,900



2007 36' Beneteau First 10R
LATITUDE 52 \$124,500



2000 32' J/Boats J/32
RHAPSODY \$109,000



1995 32' Pacific Seacraft
WINGS \$113,500



2005 40' Raider Aquapro RIB
SURF RAIDER \$218,000

SAIL.....

- 2000 42' J/42 - Reluctant \$209K
- 2006 41' J/124 - Forgiv... \$239K
- 2001 40' C&C 121 \$210K
- 2000 38' Catalina 380 \$119K
- 1993 38' Morgan 38 \$99K
- 2006 36' J/109 - Lanui 199K
- 2007 33' Cross Current \$179K
- 2001 32' J/32 - La Dolce **SOLD**
- 2001 32' J/32 - Betty **SOLD**
- 2005 30' Columbia 30 \$60K

POWER.....

- 2008 44' Renzo Coupe \$549K
- 2004 38' True North **SOLD**
- 2011 30' Back Cove 30 **SOLD**

RIBS.....

- 2009 30' RAIDER RIB 9m \$69K

DEALERS FOR:



2013 SABRE 38 SE w/Pod Drives



Introducing the New - J/70



2013 Hanse 415



2013 48' SABRE 48se

San Diego: 619.224.6200 Newport: 949.675.8053 Alameda: 510.227.2100

San Diego

Jeff Brown

Jeff@jk3yachts.com
619.709.0697

San Diego

Kenyon Martin

Kenyon@jk3yachts.com
858.775.5937

San Diego

Jack Lennox

Jack@jk3yachts.com
619.356.3881

Newport Beach

Walter Johnson

Walter@jk3yachts.com
949.421.8006

Newport Beach

Scott Poe

Scott@jk3yachts.com
714.335.2229

Alameda

Art Ball

Art@jk3yachts.com
510.304.5286

Alameda

Chris Corlett

Chris@jk3yachts.com
510.914.1073

Always a Perfect Fit!



Great Gifting Made Easy!

What makes a great gift? Truly, it's the thought that counts! So think about how much you'd like to have a shopping spree at West Marine. Now think about how much the members of your crew would love to have the same opportunity. Get the picture?

It's easy to give everyone on your list a gift they'll love. Just drop by any West Marine store, or go online to westmarine.com and order up gift cards in any amount.

Don't you wish making dreams come true was always this easy?

West Marine[®]
For your life on the water[™]

Follow us on:   

We have 17 stores in Northern California, including our Alameda Sailing Superstore!

Visit www.westmarine.com to find the store nearest you.

LETTERS

ing on the topic, and in the late '90s was one of the first to embrace this data technology. In the interest of full disclosure, we are the North American distributor for Pactor modems, which is what the *Bounty* used to send their messages. Gary and I are passionate about sending data over HF, and by highlighting the *Bounty* incident we can raise awareness — when boiled down, HF/SSB is a basic piece of safety equipment.

Eric Steinberg
Sausalito

Readers — With or without a Pactor modem that allows for sending emails and getting GRIB files, HF/SSB is a great tool for cruisers. After all, starting your own cruising net requires nothing more than picking a time and frequency, and getting your friends to participate.

*HF/SSB is great in emergencies, too, but it does have limitations. In the case of *Bounty*, they eventually lost electrical power or their antenna, severing their contact with shore. At that stage, either an EPIRB or Spot Messenger would have been of more use.*

↑↓ THIS SHOULD BE THE MOST EXCITING AC EVER

Right on! That's my response to *Latitude's* 'modest proposal' that the AC72s be dropped right now in favor of something like the MOD 70 trimarans and fleet racing rather than match racing.

Not only are the AC72s with fixed wings vulnerable to the wind and chop on San Francisco Bay, the addition of foil technology inserts a wild card that if someone hits it right —



TH. MARTINEZ / SEA & CO.

The MOD 70s would make for fantastic racing on San Francisco Bay.

look at the difference between the boards on New Zealand's cat and Oracle's cat — they could run away with the race.

I have always thought a one-design was better than a formula boat because it puts the competition in the hands of the sailors, not the designers. And I agree with *Latitude* that even existing big, fast one-design trimarans could make a thrilling America's Cup.

The worst thing that could happen would be for every AC72 boat to break in the Trials or Cup races, and the victory to be determined by default of the last boat standing.

The America's Cup in San Francisco could be the greatest since it was held in Fremantle in 1987. Someone should make sure that it happens.

Robert Hawkins
Empty Bucket, Mainship 34
Ft. Lauderdale, FL

Robert — Our only disagreement with you is our belief that MOD 70 — or similar — one-design fleet racing in the America's Cup would be much more exciting than in Fremantle. After all, San Francisco Bay offers a more spectacular viewing 'stadium', and the trimarans are three to four times as fast as the lead mines of Fremantle.

↑↓ DEED OF WHAT?

Latitude's idea of one-designs for the America's Cup violates the Deed of Gift of the America's Cup. That Larry Ellison co-opted the America's Cup name to create the America's Cup

THE FINEST SAILS BEGIN WITH THE BEST SAILCLOTH

Our patented woven Vectran® sailcloth performs like the laminates with the durability of Dacron®, especially in roller furling applications. In fact, Vectran® is lighter, lower stretch, and retains its shape over a longer life than any sailcloth we've ever offered to cruising sailors. That's because Hood Vectran® is woven, not laminated to Mylar® film. And you can be sure that each sail we roll out is built by hand, with the same care and craftsmanship that has been the Hood hallmark for 50 years. To discuss your sailcloth needs – whether our state-of-the-art Vectran® or our soft, tight-weave Dacron® – give us a call today.

**FALL
DISCOUNTS
NOW IN EFFECT
Save up to
25%**

HOOD Sails & Service

HOOD New Sails

HOOD Sail Repairs

HOOD Furling Conversions

HOOD Free Pickup & Delivery



Chesapeake

*Jim Fair's Outbound 46
with Hood Vektron
Full Batten Mainsail,
140% Genoa, and
Solent Jib*

PHOTO COURTESY
SWIFTSURE YACHTS
www.OutboundYachts.com

HOOD SAILMAKERS 465 Coloma Street, Sausalito, CA 94965

**Call Robin Sodaro (800) 883-7245 (415) 332-4104 Fax (415) 332-0943 hoodsails@aol.com
Visit our website for Special Online Discount Pricing... www.hoodsailmakers.com**

Third Reef Gear



We've improved our Third Reef Foul Weather Gear!

For years, thousands of boaters have chosen our Third Reef waterproof gear for its unbeatable combination of quality, durability and value. Now we've made it even better! Using technically-advanced new fabric, Third Reef is now lighter, easier to move in and more breathable, yet still provides complete waterproof protection when you're on the water. We've also developed a version specifically to fit and function better for women. So now there are even more reasons to choose Third Reef. The world's best-selling gear!

West Marine[®]
For your life on the water™

We have 17 stores in Northern California, including our Alameda Sailing Superstore!
Visit www.westmarine.com to find the store nearest you.

LETTERS

World Series has provided the opportunity to experience fleet races that are at once exciting and compelling. The World Series, however, is a separate show from the America's Cup.

What the America's Cup gives us is the focused advancement of boat design, material usage, marlinspike seamanship, sail design and construction, and athletic development, not to mention the development of professional sailing.

Yes, the America's Cup is a messy, dirty affair, but it does its part to make the sport just that, a sport.

Dave Wilhite
Novato

David — Deed of Gift? We say Schmeed of Gift. We're interested in the most exciting, greatest participation, 'big bang for the buck' racing possible, and think most of the stakeholders would agree with us.

We don't know if Larry Ellison or Russell Coutts was the one to come up with the current World Series and America's Cup concept, but we think they did a pretty darn good job, particularly when it has come to racing the 45s in windy and spectator-friendly venues — meaning San Francisco as opposed to San Diego. Alas, we think they overreached with the 72s, which we think at least Coutts has sort of admitted. It's no secret that none of the other syndicates are thrilled with the 72s, and they've hardly had a chance to flip their 72s yet.

You know the old racing expression when you find yourself on the wrong side of the course: 'When you got to eat shit, take big bites.' While we doubt that it's gonna happen, we think it's time for the America's Cup folks to take a big bite, unpleasant as it may be to swallow.

↑↓ A BETTER SHOW FOR ALL

As usual, *Latitude* is right on with your opinion. Although it's fun to watch those screamin' 72s — same thrill as watching a tightwire walk over the Grand Canyon, and perhaps a little morbid, too — I think safety should be a part of the spectator/gladiator equation.

Furthermore, fleet racing, as opposed to match racing, with those big trimarans, would be a far better show for all, sailors and non-sailors alike, just as *Latitude* pointed out. And with less risk to the participants. Maybe they'll even get a few more syndicates involved, due to what could be a much lower cost of campaigning one-design boats.

Tommy, Medy & Ray-dude Fowler
Living aboard
Liahona, CT-35
San Pedro

Tommy, Medy and Ray-dude — Darn tootin' there would be more syndicates involved in a less expensive America's Cup. Consider the French. They won't have an AC72 in the America's Cup, but they already have four French MOD 70 teams for a competition that doesn't have a fraction of the cachet of the America's Cup. We think the America's Cup organizers need to figure out why that is.

↑↓ USE THEM FOR EXHIBITION RACES

Aside from the possibility that there won't be any boats intact to compete for an America's Cup, it's a shame that so many countries won't be participating. No United Kingdom? No China? No Korea? Doesn't that constitute about one-third of the world's population? I think it's a loss to the Bay Area to have so few countries participating.

I say we continue the Cup challenge with the 45s in fleet racing, and maybe use the 72s in an exhibition race. Sort of

May All Your Holidays Be White, Red and Green.



Season's Greetings From Your Friends At Bay Marine Boatworks.

Twas the night before Christmas when all through the yard,
Our staff was busily creating this seasonal card.

So enjoy this message as we sail out of sight,
"Happy Christmas to all, and to all a good-night!"



310 W. Cutting Blvd.
Point Richmond, CA 94804
Yard Office: (510) 237-0140
Chandlery: (510) 234-7960
www.baymarineboatworks.com

BAY MARINE

BOATWORKS Inc.
The Sailor's Boatyard

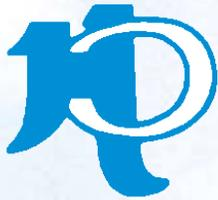

HOGIN SAILS



Locally Made & Handcrafted

**Our sails are USED offshore,
not MADE offshore!**

HOGIN SAILS

- New racing and cruising sails
- Roller furling conversions
- Repair and service
- Boom and canvas covers
- ATN spinnaker/genoa sleeves
- All sails manufactured at our Alameda loft

Call us today to discuss your sail inventory.

510.523.4388

1801-D Clement Avenue, Alameda, CA 94501
sales@hoginsails.com • www.hoginsails.com

LETTERS

how they do it in the Olympics.

Chris McKay
Marina Manager
Oakland Marinas

↑↓ MOD 70S, THE ECOLOGICAL CHOICE

It would be exciting to have the America's Cup sailed in MOD 70s. Not only could they be sailed from site to site on their own bottoms — what a fun and great challenge that would be — they wouldn't have to be thrown away after each America's Cup.

P.S.: My Crowther catamaran is one of the more famous cats from the Great Lakes, having won many trophies over the last decade. I bought her with plans for an all-female crew to race her in the '13 season, but I'm having problems putting together a team. If anyone is interested, they can contact me at multihuler@aol.com (yes, it's just one L).

Stephen Marcoe
Nice Pair, Crowther Super Shockwave
Reno, NV

↑↓ AIN'T GONNA HAPPEN

Most of us would love to see the America's Cup sailed in the big trimarans, but I don't think it will happen. The biggest advantage Ellison has in this Cup is the ability to outspend his rivals, both on the water and in the courts. Call me cynical, but I don't think he will cede that in order to have great racing in "sensible" boats.

I was back in the Bay to watch the AC45s race and found it fascinating. It wasn't like sailboat racing as I think of it, but more like a whole new sport. But I thought it was great in terms of getting non-sailors excited and involved.

P.S. Life up here in the Gulf Islands is fantastic. Maybe a little cool for the Wanderer's tastes, but a great place to raise a child and cruise in sweaters.

Dave Reed
ex-Sausalito
Pender Island, B.C.

Dave — Given the fact that the 72 design involves so much unknown territory, we think this Cup will be harder to buy than previous ones.

↑↓ I REJECT YOUR PROPOSAL, SIR!

I could not disagree with *Latitude's* proposal more. While I do agree that one-design racing is by far the most interesting

GUILAIN GRENIER / ORACLE TEAM



The America's Cup has always led to innovation in design, but is it too dangerous?

sailing format, the fundamental premise of the America's Cup has always been to leverage technology and innovative boat building practices to help you win. This technology then makes its way into mass-produced yachts, and improves the sport as a whole — much like Formula One racing does for cars. This is the genius of the AC format, and what separates it from all other forms of sailboat racing.

As for fleet racing, I prefer dragging this out with the Louis Vuitton Cup, and then the America's Cup to keep the excitement going on our Bay for as long as possible. I reject your



GET YOUR GRIP ON™

Belgian athlete Evi Van Acker provided valuable input into the development of GripX3 Technology.



In shifting winds. Over big waves. Under tricky conditions.

Sperry Top-Sider introduces GripX3 Technology,™ a patent-pending innovation that provides sailors ultimate traction through lab-proven and athlete-tested footwear technologies. Regardless of conditions or boat surface, GripX3 grabs and grips for a more confident sailing experience.

- + **Hydro-Grip™ Rubber:** Delivers maximum on-deck traction with Sperry's stickiest outsole ever
- + **Adaptive Wave Siping™:** Disperses water underfoot to reduce slippage on wet/dry surfaces
- + **Sperry Top-Deck 360™:** Integrated rubber outsole and upper provide all-around grip and performance



Watch **GripX3** in action
bit.ly/GRIPX12



sperrytopsider.com/gripx3

JUST LAUNCHED



NEW WEBSITE:
www.boatyardgm.com

We're just a 'click' away.



**CLICK
OUR
RATES!**

**FREE
HULL WAX
WITH
BOTTOM
JOB**



IT'S SIMPLE!

**Call The Boat Yard at Grand Marina
for the Lowest Bottom Prices!**

~ COMPARE US WITH THE COMPETITION ~

X. Interlux.
yachtpaint.com

AWLGRIP
AWLGRIP

CALL FOR A RESERVATION

**(510) 521-6100 • Fax (510) 521-3684
2021 Alaska Packer Place, Alameda**

LETTERS

proposal, sir!

Seth Hynes
Honeymoon, Lagoon 380 cat
Mill Valley

Seth — Watch whom you're calling 'sir'! But thanks, we appreciate your opinion.

↑↓ WHY SETTLE FOR LESS THAN THE BEST?

There's a place for one-design racing, but the America's Cup should be like Formula One: build the fastest vehicle you can dream up within the rules, and see who comes up with the fastest. It doesn't always make for great racing, but in the short-course format, with lots of opportunities to make mistakes, it should still be good to watch. Likewise, there's a place for fleet racing, but the America's Cup should stick with match racing. It's tradition, and the format should keep it watchable.

Max Crittenden
Solar Wind, Martin 32
San Francisco

Max — With all due respect, why would you settle for something that "doesn't always make for great racing?" We say to heck with tradition. We want an America's Cup that is the best combination of speed, excitement, maximum participation — and even safety.

↑↓ JUST STICK WITH THE AC45S

Before changing horses for the America's Cup, there needs to be an evaluation of what the damage was to the Oracle cat. If it's decided that the horses need to be changed, I say change them to the existing 45-footers. There are lots of them, the cost has already been met, and so many more teams could compete.

SD Katzman
Planet Earth

SD — Good points. The damage was found to be way beyond 'extensive', at least to the wing. A number of readers agree with your suggestion to go with the 45-footers. In our opinion, they don't have adequate grandeur or speed for an America's Cup. Sort of like playing softball in the World Series or flag football in the Super Bowl.

↑↓ RIDICULOUS IS THE WORD THAT COMES TO MIND

I raced and did speed trials in catamarans in the pre-Hobie days and through the mid-'80s. It was a fairly small group of renegade sailors, and through trial and error we learned just what twin hulls were capable of. Cats — unlike dogs — are sometimes uncontrollable. When I saw the first clip of Russell Coutts capsizing an AC45, I saw only two possible causes: First, I wondered if these 'professional' guys really had enough cat experience. Second, the winged cat just can't de-power fast enough to avoid crashing.

After watching Coutts T-bone the committee boat in the San Francisco World Series, I knew he wasn't a true multihull sailor. But in the case of the capsize of the Oracle 72, I think it was the boat's fault. A capsize is scary and expensive in a 72. Ridiculous is another word that comes to my mind.

As for using the AC45s, *l'Hydroptère* just kicked dirt in the 45s' faces — and with a soft sail and a much smaller budget. I think that the French sailors have proven that tris are better suited than cats for hairier conditions.

Incidentally, Dennis Conner's soft sail cat was not much slower than their winged rig. I was on a photoboat in San

10 reasons why boaters choose BERKELEY MARINA

- 1 Direct Access to the Bay**
The best boating experience as soon as you leave the beautiful harbor!
- 2 Free Mobile Pumpout Service**
Berkeley Marina has teamed with BayGreen to offer Free once-a-month mobile pumpout of your holding tank (through 2012).
- 3 Free WiFi**
The Marina now offers free WiFi access to the internet.
- 4 Sailing Schools & Clubs**
OCSC Sailing, Cal Sailing Club, Cal Adventures – More chances for learning & community!
- 5 Berkeley Yacht Club**
One of the friendliest clubs on the bay – Get involved: racing, cruising, social activities... **Now – membership fee waived!**
- 6 Berkeley Marine Center**
One of the Bay Area's most popular, full-service boat yards!
- 7 Liveaboard Permits Available**
Make Berkeley Marina your home!
- 8 Fuel Dock & Pumpout Stations**
Open 7 days a week.
- 9 Full Amenities**
Berther-only bathrooms, laundry facilities, gated docks...
- 10 Much More!**
Bait shop & deli, launch ramp, hoists, fish cleaning stations, paved parking, free washdowns for trailered boats...

Contact the Marina Office for details



It's a boating community!



CITY OF BERKELEY
PARKS RECREATION AND WATERFRONT

Berkeley Marina Office
201 University Ave. • 510-981-6740

Visit our website at: www.ci.berkeley.ca.us/marina

Outboard Engine Owners:

WE UNDERSTAND



When an engine dies, there's no walking home – just costly repairs, lost vacation time, and lost revenues.

Don't find yourself in this boat. Regular maintenance prevents expensive repairs.

We are *your* experts for outboard diagnostics, repair, repower, sales and service.



- Factory-trained and certified techs
- Open six days a week
- New and used engines bought and sold
- One-year warranty on all work performed and used engine sales
- Three-year warranty on all new engines

MARINE OUTBOARD

since 1990

OUTBOARD SALES, SERVICE, REPAIR, PARTS

(415) 332-8020

Nissan
Tohatsu
Johnson
Evinrude



Honda
Mariner
Mercury
Yamaha

35 Libertyship Way • Sausalito, CA 94965

Conveniently located at Libertyship Marina

*If we're not maintaining your outboard,
you've missed the boat!*

LETTERS

Diego, and it was amazing to see it ripping by at 18 knots in a 6- to 8-knot breeze on almost glassy water.

Apart from the risks inherent with the 72s, I think it's odd that the crews' nationalities have no correlation to the 'countries' they sail for — and emphasize the commercialization of sailing rather than the soul.

Goose Gossman
Benicia

Goose — It's just speculation on our part, but we figure the trade-off between a wing AC72 and a MOD 70 is about 5% in performance — and about 200% in the number of entries.

↑↓ THE MORE THE MERRIER

If the wing masts on the 72s are that vulnerable to catastrophic damage, the racing will be diminished. In other words, are the 72s too fragile to carry on if they tip over? At least the 45s proved — in most cases — to be tough enough to carry on after a crash.

Match racing is boring unless you're the participant. Fleet racing is the future of yacht racing as a spectator sport, and the more boats the merrier.

There is always the chance of equipment failure, of course; however a race that ends with just a few boats spread out on the course due to the competition's being out of action with wing damage will be just as boring as watching 12 Meters out for a daysail.

Lani Schroeder
Balance, Endeavour 43
Seattle

↑↓ NO ONE OWNS THE WATER

I just read an article called 'The Monetization of America's Cup Viewing Opportunities', and my worst fears have come true. The Coast Guard has forgotten the lessons we learned — and taught — the America's Cup Organizational Committee the last time the Cup graced our shores. But all is not lost.

I was the Operations Officer for the '94-'95 Coast Guard America's Cup Patrol. I was the person who wrote the Operations Manual for the Patrol and ran the meeting between the ACOC, the syndicates and the Coast Guard. During these meetings we told the ACOC what was required, but more importantly what they could and could not do.

One important area of contention was the Exclusive or Sponsor Zone. Like what is happening in San Francisco now, in '94-'95 the ACOC proposed that paid sponsors be allowed in an inner viewing zone. Normal spectators would be allowed to watch the races, but this inner zone, closer to the course, was to be exclusively for paid sponsors. In other words, sponsors would get field seats and we normal folks would be in the nosebleed section.

This didn't happen in San Diego because allowing an organization to create a zone for the exclusive use of paying customers/sponsors is the equivalent of 'selling' public waters, and was something the Coast Guard Patrol Commander would not and legally could not do. So we gave the ACOC two choices:

1) The racing area would be closed to all vessels not needed to run the races or insure safety. Meaning only Race Committee and safety boats would be allowed within the safety zone — along with the boat used to televise the event. No sponsors or spectators would be allowed on the race course. Outside the edges of the safety zone, all vessels had equal rights.

2) The second option was there would be no safety zone, so the race course would be open and just like a normal race, where recreational vessels could go anywhere they pleased.

Discover the difference!

- ▶ Certified Quality
- ▶ Custom Sail Washing
- ▶ Expert Upgrades & Recuts
- ▶ 11 Point Sail Inspection
- ▶ Winter Sail Storage
- ▶ Pick up and Delivery

When it comes to sail care, *there is a difference!* All North Certified Sail Care follows North Manufacturing Blue Book quality standards for construction and materials... *even if your sail is not a North sail!* Now is the time to bring in your sails and sail covers for inspection, repairs, washing and upgrades.

SAVE 20%

*when you bring in your suit of sails for sail care. Hurry! Offer expires 12/31/2012.**

*Offer is limited to North Sails Sausalito location as is limited to boat size 50ft. LOA or less. Offer expires December 31, 2012. other limitations may apply.



Better by Design

Sausalito

415-339-3000

2730 Bridgeway, Sausalito, CA 94965

www.northsails.com

Rick Linkemyer photo

Two Unique Boat Products From Scandia Marine

MARINE LADDERS

DEPLOYABLE FROM THE WATER



THE LINKS MAKE IT RIGID

- Electropolished 316 Stainless
- Easily Extended and Collapsed
- Rigid - Will Not Kick Under



UP-N-OUT

ULTIMATE MARINE LADDERS By Scandia Marine Products

30% PRE-SEASON DISCOUNT

Good On Any Size Wheel Up to 63" Through 2/28/13



ColorWheelz

VINYL DIPMOLD WHEEL COVERS

(651) 464-5058

www.scandiamarineproducts.com



LETTERS

Obviously, the ACOC chose the first option. In a compromise, we did allow the ACOC to have one non-operations yacht on the race course. This yacht was used by the ACOC members and they would be allowed to have some sponsors aboard. This was the only vessel not used to run the race or for safety that was allowed on the race course.

Although I was the Operations Office, I was not the one making the final decisions. The Commander of the Patrol was a very senior and well-respected captain — actually, he was the real life captain who had been in *The Perfect Storm*. He made all the final calls, and this was one he would not compromise on.

I recently moved back to the East Coast, so this really doesn't affect me anymore. But if I still lived in Pt. Richmond, I wouldn't put up with this. Normal spectators have all the same rights to the water as paying sponsors. There are no grey areas here.

Cam Lewis
Timmy, Elliott 6.5
ex-Pt. Richmond
Wickford, RI

Cam — The thing we remember about the America's Cups in San Diego was that the official press boats weren't allowed within about 50 miles of the racing boats, which is why we and many other reporters 'watched' the event from press headquarters. And back then, video coverage of the racing was positively prehistoric compared to what Stan Honey gives us these days.

Philosophically, we're with you in that nobody has more rights to the ocean than others — except for commercial fishermen, who can get rich by virtue of having a permit. In practical terms, however, we think it would actually add to the America's Cup to have some megayachts sprinkled around. San Francisco progressives always need somebody to hate, and folks with megayachts would fit that need perfectly. Of course, we're also the folks who thought a San Francisco megayacht marina, long ago nixed for political reasons, would quickly become one of the biggest tourist attractions in San Francisco. So while we're philosophically against it, the pragmatist in us wouldn't mind if perhaps 25% of the offshore course viewing area were set aside for megayachts.

↑↓ I WANNA SEE, TOO!

This is an email I sent to any and all I could think of who are involved in the AC:

First off, to every one of you involved, thank you so much for all your work to make this America's Cup a completely new and exciting event, and most of all for holding it in San Francisco, my backyard. I couldn't be more amped to have you all in town.

Other than the fantastic television graphics, I believe the most important thing you've done is to bring the race to the fans, close enough to shore for everyone to have a great view. I've been sailing off and on for 15 years, and of course I'm interested in the America's Cup, but the viewing spectacle you have created with the ACWS by bringing the races to the shoreline has opened up this sport to so many new people. I had to twist the arms of every non-sailing friend of mine to get them to attend the August ACWS, but afterward they were all ecstatic at how close the boats were and how we could hear them yelling commands at each other, and all were eager to attend the October races.

I'm sad to report that I received equally negative feedback from all the new fans I created after the October event. They

ENJOY



YOUR ADVENTURE...

We take care of your boat engine



Full Service for marine CAT® engines

- Engine repair and service
- Engine repowering and rebuilding
- With **CAT® Original parts &** certificated technicians
- Keep your **CAT® engine** warranty with us



If you are coming to Puerto Vallarta
CONTACT US and schedule your engine service

▶ info@catmarineengines.com
▶ www.catmarineengines.com



On second thought...



This season, give Svendsen's Chandlery gift certificates. (But keep one for yourself.)



SVENDSEN'S CHANDLERY

Gift Certificates available in the Chandlery (1851 Clement Ave. in Alameda) or online at svendsenmarine.com. Phone: 510.521.8454.

LETTERS

were all disappointed, as was I, in the change of course, which moved the course away from the shore, and which meant the competitors were more than a couple of hundred yards away. In and of itself, this wasn't that big of a deal, but what I found atrocious was that you (or some other regulating body) allowed boats to come into the area between the shoreline and

ACEA/GILLES MARTIN-RAGET



Shoreside spectating in October was less than perfect.

the course and motor, anchor or otherwise block the view of those attempting to watch from the shoreline.

Please, please change this policy for next year! My understanding was that this October there was a 'No boats with more than five feet of freeboard' rule. But I

have two comments regarding that:

1) No one enforced the rule, and my friends and I were completely blocked out from Spithill's pitchpole on Saturday by two large power boats, and

2) Even if the five-ft rule were to be enforced, imagine 100-200 five-ft-freeboard boats lining the viewing area. Sitting on shore I'm at best five feet above the water so all I'd be staring at during the races would be the sails of the AC72s (thank goodness for their immense size) — I wouldn't see the crew or the marks.

This would be a tragedy for something you all have worked so hard for. Please consider this for future races.

Chris Glubka
SeaGlub, Hylas 46
San Francisco

Chris — Latitude agrees that the racing should be held as close to shore as possible. The way the course was set up for the August World Series was perfect. It allowed regular people such as ourselves the equivalent of sitting on the floor during a Warriors basketball game or behind home plate at a World Series-winning San Francisco Giants game. We also agree that spectator and other boats should be prohibited from blocking the views of spectators on shore. The good news is that GGYC Commodore Norbert Bajurin says that future ACWS races, as well as the Louis Vuitton and AC itself, will offer the same viewing as in August. The October viewing issues, he says, were due to the Coasties' strict rules for Fleet Week.

↑↓NASA'S CURE WORKS FOR ME

I just read the letter from Adam Scheuer requesting suggestions for seasickness remedies for his wife. I feel for her since I have a comparable issue, such that I use a prescription medicine and don't leave the dock without it.

Long ago I had a 'situation' — it's a very long story — and was so horribly seasick for three days that I couldn't even keep water down. The usual over-the-counter drugs — as well as going outside, looking at the horizon, and other 'remedies' — did nothing. After I returned to shore, I felt I had to find something that worked or — perish the thought! — give up sailing.

Issues of NASA Tech Briefs were available where I worked, and there was an article in one about a medicine NASA gave the astronauts for motion sickness. I took the article to my doctor and had him write a prescription. I have been using it ever since, and that means for more than 35 years.

Almar Marinas

Everywhere you'd like to be



Est. 1973



Martinez Marina 925.313.0942

Join one Almar Marina and enjoy reciprocal privileges at any of Almar's 16 locations from San Francisco to San Diego and out to Hawaii. Each marina provides programs and events that are included in your slip fees:

- *Boat Handling
- *Navigation Courses
- *Electrical Courses
- *Anchor Outs
- *Seminars on Local Destinations

almar.com



WHALE POINT MARINE & HARDWARE CO.

A FAMILY OWNED & OPERATED BUSINESS FOR THREE GENERATIONS
ACE Hardware
 MARINE PARTS & ACCESSORIES, PLUS A COMPLETE HARDWARE STORE

Go to **WhalePointMarine.com** for additional discounts!

FURRION
 Shore-Power Cord
 30AMP



25' **\$69⁹⁹**
 50' **\$79⁹⁹**

DOCK RITE
 Fenders



4-pack
 5.5"x20"
\$47.99

DELUXE BOSUN'S CHAIR

Hard bottom seat. Large SS D rings let you snap in shackle and tie in a safety line.



NOW \$89⁹⁹

GOLDBRAID
 Nylon Dock Lines
 With approx 12" loop in 1 end.



3/8" x 15'..... \$10⁹⁵	1/2" x 20'..... \$16⁹⁵
3/8" x 20'..... \$12⁹⁹	5/8" x 20'..... \$24⁹⁵
1/2" x 15'..... \$16⁹⁹	5/8" x 25'..... \$29⁹⁵

GILL Rigging Knife

Comes with case



Now \$21⁹⁹

GILL Deckhand Gloves

FREE with purchase of Gill Foulweather Gear Suite



Gill — present quality in sailing gear. Sizes: S, L & X.
 List \$21.99 • **NOW \$19⁹⁹**

CRAFTSMAN
 Multi-Tool



Cordless **NOW \$89⁰⁰**
 With Cord **NOW \$79⁰⁰**

MUSTANG Float Coats



MJ6214TI • Bomber Style • **\$239⁹⁹**
 MC1524 • Long Jacket • **\$299⁹⁹**

205 Cutting Blvd, Corner of 2nd, Richmond
510-233-1988 • FAX 233-1989
 Mon-Sat: 8:30am - 5pm • Sun: 10am - 4pm • whalepoint@acehardware.com
 Go to **WhalePointMarine.com** for additional discounts!

LETTERS

The prescription was promethazine in a liquid form — do not get it in pills. It used to come with ephedrine, such as was mentioned as 'the Coast Guard Cocktail'. But they do not put the ephedrine in it anymore. I guess they feel someone will extract the ephedrine from the promethazine to make meth. Oh well.

The beauty of promethazine in liquid form is that it works — for me, anyway — in about 10 minutes, and does not have to be taken ahead of time. In addition, I and others have been on passages where we felt fine, then started feeling seasick. Then "things happened" and the seasickness started. Promethazine could be taken at that time and, within minutes, the sickness had subsided (for me).

I have shared my promethazine with a number of sailors who have claimed they never get seasick, but who then had things happen. They have been amazed at the results.

Although I am also not a medical doctor, and do not suggest altering recommended dosages, I have found that I can sometimes take half a dose just before sailing out the Gate, and that's all it takes. But if there is an ebb with wind, I take the whole dose, which for me is one teaspoon. My prescription says that I can take it every four hours, but I rarely have to take it again after the first dose. That is unless conditions change. I have never had to take it for a whole day or over several days.

The side effect for me is a bit of drowsiness for the first hour or so if I am not busy — which is rarely the case, especially when singlehanded out to the Farallones!

I know that some remedies work for some people but not for others. All I can say is that promethazine has worked for me for decades, as well as for many sailing friends.

I sincerely hope that Adam's wife — doesn't she have a name? — finds something that works for her. I know I'm one of those people who can't be 'cured' of seasickness, so I just keep my little bottle handy.

Patricia Zajac
 Rusalka, Offshore 40
 Richmond YC

Patricia — Thanks for your report.

But please folks, don't share prescription medicines except in extreme emergencies. Drugs such as promethazine are powerful, and not appropriate for pregnant women and people with other medical situations.

Oh, and for the record, we contacted Adam to find out his wife's name but he never responded.

LOOK UNDER YOUR OWN NOSE

Latitude asked readers to help a seasickness-susceptible woman with cruising aspirations to learn more about the malady. Look under your nose at Dr. Kent Benedict's article titled 'The Taming of the Spew', which can be found at www.latitude38.com/features/seasickness.html#.UJMG5GOe9Vw.

Ed Fagan
 Shebeen, J/30
 Ipswich, MA

Ed — Thanks for the reminder. We think 'The Taming of the Spew' is about as definitive a sailor's guide to seasickness remedies as there is, but as it was written in '97, we wanted to see if anybody had anything new.

When it comes to prescription medicines — which Benedict recommends as a last resort — he wrote: "There are basically three categories of drugs which have anti-seasickness effects. The first and most familiar group are the antihistamines: dimen-



Paradise Village
MARINA
BANDERAS BAY

Voted best Marina in Mexico

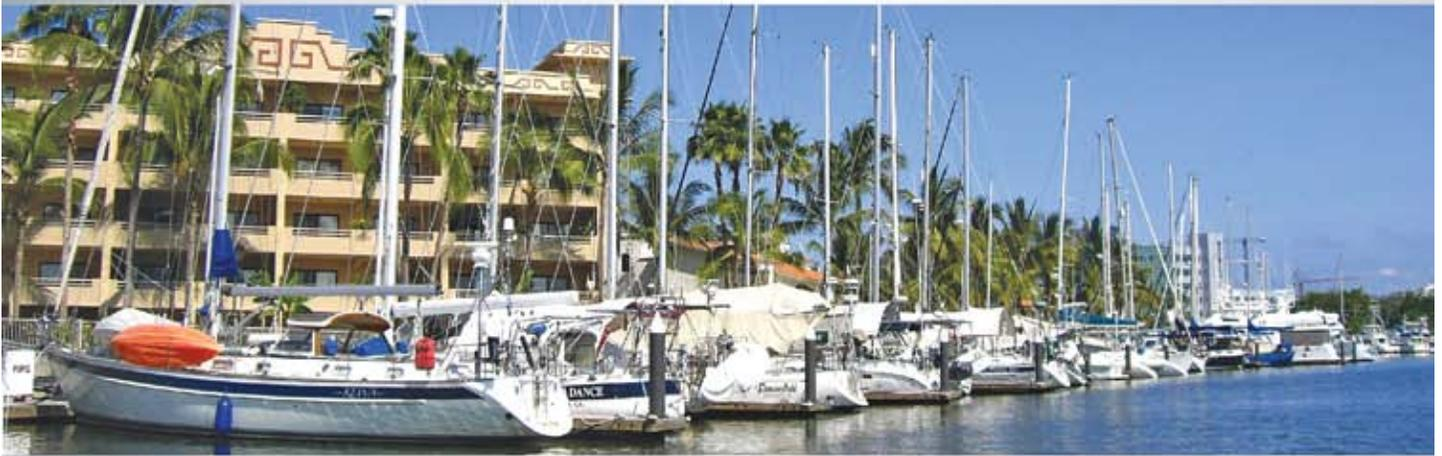

Services:

- Electrical service, 110/30 amps · 220/50 amps, 3 phase 100 amps and 3 phase 480v · Crystal Clear Potable Water ·
- Cable TV · Garbage Collection · Pump - out Station · Fire Fighting Boat Protection · 24 Hrs. Security · Computerized gate access ·

Additional Services:

- Vallarta Yacht Club · Special area for marina guests · Restrooms · Lockers · Showers · Pool and jacuzzi
- Free access to all the facilities of our 5 star hotel · White sand beach · Dive tank refilled · Propane refill · Launch ramp

CONTACT US: marina@paradisevillagegroup.com

Phone & fax from U.S. 011-52-322-22-66728 · GPS Coordinates: 105° 17.9 W 20° 41.2 N

**Our Best
Sailing
Lesson
Offer
Ever!**



**Your Best Gift Ever!
For them or YOU!**

**ONLY
\$695**
for weekday package
\$995
for weekend package

Includes:

- Basic Keelboat Course
- Basic Cruising Course
- Bay Cruising Workshop
- 1 Year US Sailing Membership
- Club Nautique Membership
- All Course Materials
- US Sailing Certification to skipper boats up to 34'
- Classes in Alameda or Sausalito



Call Today!

Sausalito 800-559-CLUB
Alameda 800-343-SAIL

**Club
Nautique**
You're at the helm!
www.clubnautique.net

LETTERS

hydrate (Dramamine), meclizine (Bonine, Antivert), cyclizine (Marezine), and promethazine (Phenergan). Actually, promethazine is in another group of drugs called phenothiazines, but it has powerful antihistamine properties.

Interestingly enough, promethazine, the medicine that works so well for Patricia Zajac, is Benedict's ultimate last resort. "What to do when all has failed and there you are — puking, feeling miserable, unable to eat or drink, and worried that you might soon become dehydrated? About the only thing left at that point is promethazine via injection or rectal suppository — 50 mg should usually do it, maybe repeating every few hours as needed."

ON CHECKING INTO MEXICO

My wife Carol and I are working feverishly on *Unleashed*, our Hardin 44, to get her ready for next year's 20th Baja Ha-Ha Rally. One thing I wondered about — and it was mentioned in the 'Paul Put Seasilk Aground at Mag Bay' article — is how cruisers go ashore in Turtle Bay and Bahia Santa Maria before they have checked into Mexico. Last year a couple of immigration officials made the trip to Bahia Santa Maria to help Ha-Ha boats check in, but normally Ha-Ha boats don't check in until they get to Cabo San Lucas.

Paul Bailey
Unleashed, Hardin 44
Seattle

Paul — Up until October of this year, Mexico didn't seem to mind that cruisers stopped along the 750-mile Baja peninsula before they checked into the country. But the immigration laws have changed, and Immigration announced that as soon as this year's Ha-Ha was completed, it would no longer be allowed.

From now on, cruisers who want to stop along Baja before Cabo will have to clear into Mexico at Ensenada in order to be legal. We understand the reasoning behind this, but know that it has the potential to create significant logistical problems with next year's Ha-Ha. Which is why we're already working with Mexican officials to solve such problems.

SURFING CONTACTS

I just read about Liz Clark of the Santa Barbara and French Polynesia-based Cal 40 *Swell* breaking her neck while body surfing at San Diego's Torrey Pines beach.



COURTESY LIZ CLARK

Dog the Bounty Hunter and Liz Clark during her 'hairy' recovery. Separated at birth?

I've surfed that area and know it can be a wicked little break. The waves have more power than you might expect. In fact, we call the spot Contacts, not just because my friend lost his contact lenses in the surf, but because you often make contact with the bottom. I've done a Liz Clark-style head plant there a couple of times, and can tell you, when you feel that tingle in your fingers and toes, you know you had a close call.

I hope Liz recovers quickly.

Paul Clausen
San Diego



Great
Location

Deep Draft
(510)
236-1013



With a 12-ft deep entrance channel you can sail
from Marina Bay
whatever the tide!

**NOW
BOOKING
FOR 2013
SEASON**

Available slips with
15' or more depth:

40' long	15.6' wide	16' deep
42' long	15' wide	17' deep
44' long	16.6' wide	18' deep
56' long	20' wide	16' deep
61' long	18' wide	16' deep

End-ties to 100'+ and 16'+ deep

On the Water: 37° 54' 45" N 122° 21' 00" W

Online: www.MarinaBayYachtHarbor.com



**SOUTH
BEACH**
H·A·R·B·O·R

South Beach Harbor is a great way to experience San Francisco. Boats of all sizes are welcome in our protected deepwater harbor. Bring your boat to South Beach and enjoy all the attractions of the city.



- Two guest docks for boats up to 125'**
- 20 guest berths up to 50'**
- Casual and fine dining nearby**
- Adjacent to AT&T Park**
- Easy access to transportation**
- 24 hour security**
- Free pump-out stations**



For Reservations:
415.495.4911 (x1111)
fax: 415.512.1351

www.southbeachharbor.com

LETTERS

↑↓DC'S PHLEET

In the October 22 *Lectronic* you wrote that Dennis Conner owns 30 sailboats. I'm sure that I'm not the only person who would love to see an inventory. I Googled it like crazy, but came up dry.

David Demarest
Burbujas, Vanguard 15 #2004
San Anselmo

David — It was Dennis himself, our new best friend, who told us that he owns 30 sailboats. Since Dennis says all kinds of shocking things for effect, most of them as hilarious as they are dry, we didn't necessarily believe him. But when Patrick Langley, who seems to spend as much time working on Dennis' boats as we work on Latitude — meaning just about every waking minute — confirmed it, we bought in.

Patrick prefaced listing Dennis' boats by admitting that he hadn't seen a number of them in years. But he started off with



CYNTHIA SINCLAIR

'DC's Pholly', one of 30 or so.

the Farr 60 Stars & Stripes; the Nelson/Marek 43 Menace XXIV; various IACC America's Cup boats that charter out of San Diego; a half-interest in the 139-ft America's Cup replica America; two Etchells in San Diego; two Etchells in Australia; Fame, the 41-ft 1910 schooner without an engine; Splendor, the Sparkman & Stephens 48 he just bought from the Driscoll family; and DC's Pholly, the J/105 he just bought and used to take third in the J/105 North Americans.

Seeing that Patrick was wearying from going down the list, we asked him how many people Dennis has working on his boats. "When I started about 10 years ago, he had close to 100 guys on the payroll," Patrick responded. "Now it's pretty much just me and an occasional helper." Apparently the more time you spend around Dennis, the dryer your humor becomes.

One day we were riding our bike through Driscoll's Boat Yard in San Diego — which is not only where we keep Profligate at the beginning and end of each summer, but is also the most fun place we've ever lived — and we saw Dennis having a beer and watching the tireless Patrick working on the bottom of Dennis' new-to-him Splendor. Being a nosy journalist, we rode on over.

"You're a smart guy," Dennis says to us without any kind of introduction or preface. "What kind of bottom paint should I put on my new boat?"

We demur, saying that he clearly knows much more about bottom paint than do we.

"No, no," Dennis insists, "you're a smart guy, tell me what kind of paint I should put on my new boat."

We shrug.

"You're so lucky," Dennis then says apropos of absolutely nothing. "You're a young guy with lots of hair and no wrinkles. I'm in my 70s, my face is wrinkled, and I don't have any hair."

Dennis, who has a full head of hair and is just a few years older than we, says all this without cracking a smile. We're laughing our ass off inside. When it comes to one-liners, Dennis could have given Rodney Dangerfield a run for his money.

"Well then, tell me what I should do with this boat," Dennis says, careening off onto a new gybe, while gesturing at Splen-

Come Visit Us Today!

SOUTH BEACH SAILING CENTER

at the
beautifully renovated Pier 40 in San Francisco

*Winter project you've
been wanting to do?*

**10%
DISCOUNT**
on Interior Woodwork
& Interior Cleaning



*"I visited the boat yesterday.
I seriously did not recognize her.*

*She is stunningly beautiful
and I am very happy with
the work that was done.
It was like coming home
to an entirely new boat."*

*- Chris Vandervert
Catalina 30*

Westwind

Washing • Waxing • Varnishing

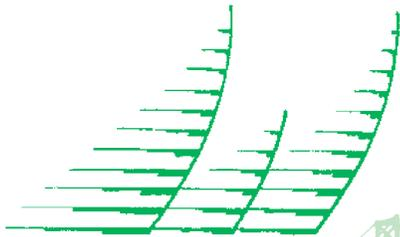

(415) 661-2205



Pier 40, South Beach on the Embarcadero • San Francisco
Call Toll Free **888-828-6789**

westwinddetailing@sonic.net
www.boatdetailing.com



**Industrial Fabrics Association International Outstanding
Achievement Award – Marine Interior Upholstery**

**NORTH
BEACH
MARINE
CANVAS**

Custom Yacht Upholstery!

nbmc@earthlink.net
www.northbeachmarinecanvas.com
415.543.1887

South Beach Riggers

**DO IT ONCE.
DO IT RIGHT.**

PERIOD.

- Mast
- Fabrication
- Insurance Work
- Rigging
- Hydraulics
- More...

www.SouthBeachRiggers.com

415.331.3400

Come see us in Sausalito
399 Harbor Dr., Sausalito, CA 94965
9am - 5pm M - F



Adjacent to South Beach Harbor and AT&T Park • Close to dozens of fantastic restaurants and shops

LETTERS

dor in a way that suggests he has absolutely no idea why he bought her.

"Just the same as you did with Cotton Blossom and Brushfire," we suggest. "Buy a new set of sails, win a few races, then sell her for a huge profit to somebody in Europe or a recently retired government department head in San Diego." On a bit of a roll, we keep going. "Better yet, take her back to Newport, Rhode Island, where they love the S&S pedigree, win a bunch of races, and sell her to some rich guy who wants to park a boat Dennis Conner once owned at the dock behind his Rhode Island mansion."

"If I was going to do that, I'd take my schooner Fame back East," Dennis counters.

"Is she the one that doesn't have an engine, which why the competitors in Ancient Mariners Regattas complain about her rating?" we ask. Two can play this passive-aggressive game.

Dennis doesn't blink, but mumbles something less than complimentary about journalists in general.

"Wait a minute," we say, a light having gone off in our head. "Take Splendor back to Newport, win a few races, then take her down to Dennis Conner's North Cove Marina in Manhattan, the only marina in Manhattan, and sell her to some Wall Street guy looking for a nautical status symbol."

"I'm never going to race Splendor," Dennis proclaims.

We find this hard to believe, because Patrick has gotten Splendor's bottom as smooth as a newborn baby's butt, and he says he's hardly begun the process.

"Look at the boot stripe," Dennis says to us. "About a quarter of it is underwater toward the back of the boat. What should I do about that?" He asks the question as if he's a first-time sailboat buyer from the hinterlands of Nebraska.

"We think it's fine," we tell Dennis. "There's probably just a bunch of heavy stuff that's collected in the back of the boat over the years that needs to be taken out to restore her to her proper trim."

"That's not it," says Dennis says derisively.

Just then Chuck Driscoll rides his bike toward the front gate to go home for the day.

"Chuck! Chuck! Come on over!" hollers Dennis.

We can tell there are other things that Chuck would prefer to do, but a client is a client, and Dennis is Dennis.

"Look at that boot stripe," Dennis complains, as if it were something Chuck had purposely done the day before to annoy Dennis. "It's partly underwater in back."

"Well," Chuck explains calmly, "there's just a bunch of heavy stuff that's collected in the back of the boat over the years, so she's a little out of trim. Take the stuff out and the boot stripe will be fine."

It's all we can do to keep from bursting out in laughter. A video team has been coming to Driscoll's periodically to shoot a boatyard-based reality television show, but they are missing the good stuff by not being here.

Dennis Conner is Dennis Conner, so he doesn't care what Chuck or we think. Indeed, he decides to have Patrick go to all kinds of trouble and expense to slightly redo the boot stripe.

A couple of days later, we swing by Splendor to watch Patrick tape off the new bootstripe and fair the bottom even more.

"We bet Dennis was bullshitting us when he said he's not going to race Splendor," we say to Patrick.

"No," says Patrick, in a friendly but certain tone.

"How can you be sure?"

"I keep the calendar for all of Dennis' boats," he says with a smile.

We've always been curious about Dennis Conner's North Cove Marina in Manhattan, wondering if Dennis owns a little



15% OFF
SAIL KITS & FINISHED SAILS

EXPIRES DECEMBER 31, 2012.

Start your sailmaking adventure today with a custom Sailrite Sail Kit (or a finished sail if you're short on time). All sails are designed and plotted by our sailmaker, Jeff, in Indiana. Expect the best in materials, equipment, and craftsmanship. Plus all kits come with detailed step-by-step instructions, phone support, and your own cheer block.

GET A CUSTOM QUOTE
800.348.2769
www.sailritesails.com

35-60' slips

Own a Dock on San Francisco Bay

Perfect Location - Great Investment!

EMERY COVE
YACHT HARBOR

Come secure a front row seat for the cup races in 2013

- **BUY A SLIP** - Save money and earn equity! Enjoy tax savings. Listings start at \$35,000. Emery Cove Yacht Harbor is the only marina on the Bay with FEE SIMPLE (not a grounds lease) dockminium ownership.
- **RENT A SLIP** - 35-60' slips, rates from \$9.25 to \$10.25 per foot.
- **AMENITIES** - Free Wireless Internet and Marina Guard® ground fault monitoring.

ON PREMISES

- ChartersSF • Emeryville Yacht Club • Mathiesen Marine
- Michael Wiest Yacht Sales • SailTime
- Seaward Coastal Ventures



CALL FOR A MARKETING PACKAGE | 510-428-0505

3300 Powell Street, Emeryville, CA 94608 | www.emerycove.com | Email: info@emerycove.com

Michael Wiest Yacht Sales

QUALITY SAILING YACHTS



Scan with your smart phone for a list of our yachts.

Three convenient San Francisco Bay Locations!

3300 Powell St, Emeryville | (510) 601-5010

25 Third St, San Rafael | (415) 453-4770

400 Sierra Pt Pkwy, Brisbane | (650) 589-8990

www.mwiest.com



47' WAUQUIEZ \$229,000
(415) 290-1347 • Mark



44' MOODY \$199,000
(510) 917-7749 • Michael



40' CALIBER \$189,000
(510) 917-7749 • Michael



37' PACIFIC SEACRAFT \$159,000
(415) 290-1347 • Mark



41' PEARSON \$28,500
(510) 410-5401 • Bill



40' BRISTOL \$64,000
(510) 917-7749 • Michael



36' HUNTER \$144,000
(510) 917-7749 • Michael



35' FUJI \$44,000
(415) 290-1347 • Mark



32' WESTSAIL \$39,900
(510) 917-7749 • Michael



35' SANTANA \$16,000
(510) 917-7749 • Michael

- 35' SANTANA, 1979..... \$19,900
- 34' SAN JUAN SLOOP, 1984..... \$19,900
- 34' ISLANDER, '69 \$26,000
- 29' FARALLON SLOOP, 1976..... \$18,995
- 28' HUNTER, '87 \$19,500
- 24' CORSAIR SPRINT, 2008..... \$48,900



- NEW
- USED
- REFINANCE



Boat Loans Made Easy®



Let our 30 years of experience go to work for you!

Call
866-377-3948

www.essexcredit.com

EQUAL CREDIT OPPORTUNITY LENDER

Loan Amounts from \$25,000
Instant Loan Approvals* • 90 Days to First Payment*

*Subject to Loan Program Guidelines and Credit Approval
Reference Code = MAR931

LETTERS

percentage of it or gets a royalty for the use of his famous name, so we ask around. "Dennis owns it," someone in the know told us with finality. "Dennis is not just a very good sailor, he's a very smart businessman."

Based on the number of sailboats Dennis owns, we should have known.

There's a funny coda to all this. As we were talking to Patrick about the dozens of boats he takes care of for Dennis, Pat-



LATITUDE / RICHARD

Patrick Langley, the Michelangelo of boat bottoms, pauses while perfecting the bottom of 'Splendor', the boat Dennis Conner says he won't ever race."

rick confessed that he himself was down to only five or six boats. Stunned that someone who spends just about all his time working on Dennis' boats could possibly own more than one boat of his own, we asked what they were. "Well, there's the 80-ft schooner Old Glory, Oslo, a Norwegian rescue boat I

live on, a 60-ft fishing boat in the Northwest, and a couple of others." We suppose Patrick can be forgiven for not being able to remember them all.

↑↓ "NO WONDER EVERYONE LOOKED AT US FUNNY"

I laughed when I read the Wanderer's November 7 *'Lectronic* item about overprovisioning for *Profligate's* last several cruises to Mexico. We're still working on eating some of the nonperishables we took on the '10 Ha-Ha, stuff we brought all the way back home on our Bash back to Northern California. No wonder everyone looked at us funny in San Diego as we loaded cart after cart of food onto our boat, losing inch after inch of waterline in the process.

Scott Emmons
JaneO, Privilege 39
Somewhere in the Delta

Scott — Overprovisioning is a waste in so many ways, including the fact that it detracts from a boat's handling and performance.

↑↓ WHAT A DIFFERENCE A FEW METERS CAN MAKE

I was reading your fine publication this month when I came across an article that tried to make a distinction between 'piracy' and 'robbery'. I'm a student of maritime law, and would like to reference an insightful article in the Maine Law School's *Ocean and Coastal Law Journal*:

"In recent years, nations have exercised the right of approach and visit most often in cases concerning maritime piracy. Piracy is 'any illegal act of violence, detention, or depredation committed beyond the territorial sea for private ends by crew or passengers of a private ship or aircraft against another ship, persons, or crew.'" [This is the definition in the United Nations Convention on the Law of the Seas, Dec. 10, 1982] "Private" acts refer to acts not committed by public officials for a public or state purpose.

Typically, piracy involves some pecuniary interest or private political motive, such as maritime terrorism. For a violent act to meet the legal definition of piracy, it must be committed outside a state's territorial waters. Acts occurring inside territorial seas are classified as "armed robbery at sea," and are the responsibility of the coastal state to suppress. Thus

PHOTO: DAVE TOWLE



Discover
Brisbane
Marina



From Hwy 101, take the Sierra Point Pkwy exit and follow the signs to the marina.

GREAT LOCATION! Just minutes to Central Bay sailing.

GREAT STAFF!

GREAT RATES! Starting at \$6.02/foot!

MARINA GREEN with picnic/BBQ areas, Bay Trail Access and FREE Wi-Fi.

**HOME OF THE
SIERRA POINT YACHT CLUB**



400 Sierra Point Parkway
Brisbane, CA 94005

www.ci.brisbane.ca.us

(650) 583-6975

harbormaster@ci.brisbane.ca.us



53 years of worldwide service ~ Shipping to every ocean

- Expert staff
- Used hardware
- Special Orders
- Lowest Prices for new items
- Service loft, modifications, cleaning and repairs

SAILS ♦ SHIP STORE ♦ CONSIGNMENT

**Brand New Coastal Cruising Sails For All Boats –
SUPER LOW PRICES**

(410) 263-4880

www.BaconSails.com

116 Legion Ave., Annapolis, MD 21401

Ballenger Spar Systems, Inc.

**Custom Racing and Cruising Spars
Expert Design and Consultation**

- Carbon and Aluminum spars
- Rod and wire rigging
- Hi-tech and conventional halyards
- Spar kits, extrusion
- Repair and modification
- Custom fabrication, waterjet and CNC
- Hardware, sheaves, spreaders
- Bay Area pick-up and delivery
- **Discounts** on halyards, standing rigging, deck hardware, furlers, Navtec integral cylinders
- Over 40 years experience!

**Call about Carbon Spars.
Masts • Booms • Poles**

www.ballengerspars.com

831/763-1196

831/763-1198 (fax)

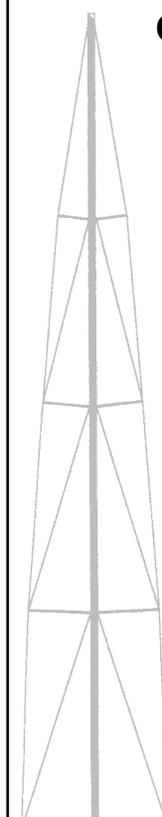

LETTERS

what's "armed robbery at sea" in territorial waters can, a few meters farther out, become "piracy."

The article was written by CMD James Kraska, US Navy.
Jorge Valcarcel
Wire, Custom Steel/Aluminum Sailboat
Saugerties, NY

Jorge — We hadn't really thought of that distinction, but it strikes us as being valid.

↑↓AFTER THIS, WE GIVE UP

I know we've had very long discourses on the subject of dangerous waves, and never seem to get anywhere in our difference of opinion about what makes dangerous wave conditions off San Francisco. But if you look back at our previous correspondence, you'll see that many more mariners have died since then. And they died because of the sneaker waves that we all talk about.

I have kept track of all the lives that have been lost because of these waves in just the San Francisco area, and the number is staggering. Avoiding sneaker waves is a simple matter of checking the wave periods on a computer before going out. If the period is in the 12 seconds or more range, mariners should be very careful about going into shoal waters such as the Potato Patch, the South Bar or the Farallon Bank.

I think that *Latitude* could write a very interesting article about wave periods and freak waves that would save lives. In my earlier emails I gave you the names of some of the world's best researchers on this subject. I think you owe it to your readers to do an in-depth piece on this very important subject. Or you can just leave it as it is, and let the death count increase.

Tony Badger
Kingfish, Fisher 37
Sausalito

Tony — We just got off the telephone with Mike Leneman, who has been a professor of oceanography at a number of colleges and universities in Southern California. He is also an enthusiastic multihull sailor and the owner of Multi Marine in Marina del Rey. We explained to him that you contend that the longer the wave period, the more dangerous waves are to boats, while we contend just the opposite.

We hate to tell you, but the professor says that we're right and you don't know what you're talking about with regard to either the dangers of long-period waves or rogue, aka 'sneaker', waves.

Professor Leneman explains that when it comes to waves, the three important measurements are: 1) The wave length, meaning the distance between two crests; 2) the wave period, which is the amount of time between two crests; and 3) the height of the wave, meaning the distance between the crest and the trough.

"The thing that makes waves dangerous to boats on the ocean is how steep they are," says Leneman, "meaning the ratio of how high the wave is to the distance between the crests. The maximum steepness of a wave is 1 to 7, because water won't stand up any higher. When waves exceed that 1 to 7 ratio, they break.

In view of this, Tony, does it not appeal to your common sense that 8-ft waves 8 seconds apart would be much steeper — and therefore much quicker to break, and therefore much more dangerous — than 8-ft waves every 18 seconds, which wouldn't be steep at all?

Professor Leneman also gave us the scientific explanation for rogue or sneaker waves. He explained that, as all surfers and

What's in a Winch?



Inside every Lewmar Winch, you'll find bronze and stainless steel materials, precision CNC machined for maximum efficiency, durability and strength-to-weight ratio. And because of our aggressive in-house testing program, Lewmar Winches have proven themselves time and again in the roughest conditions and on the toughest racing courses.



Simple Servicing -
No Tools Required

Features

- Broad Range
- Most Powerful in Class
- Easy Fitting & Servicing
- Wavespring Self-Tailer
- Needle Peen Drum
- World Wide Service Network



Proven Needle Peen Drum

Find Lewmar products at:

Svensden's Marine
Alameda, CA
510-522-2886

Sailing Supply
San Diego, CA
619-225-9411

Port Townsend Rigging
Pt. Townsend, WA
360-385-6330

Rigworks
San Diego, CA
619-223-3788

Fisheries Supply
Seattle, WA 206-632-4462

KKMI - Richmond, CA
510-237-4141

LEWMAR
www.lewmar.com

Yachtfinders/Windseakers

in the heart of
San Diego's boating community

2330 Shelter Island Dr. # 207, San Diego, CA 92106

info@yachtfinders.biz

www.yachtfinders.biz

(619) 224-2349

Toll Free (866) 341-6189

LEADER IN
BROKERAGE SALES
ON THE
WEST COAST!



48' MARINER MAYFLOWER CC, '83 \$139,950
Many upgrades made allowing you to cruise in comfort and security. If your intentions are to cruise the blue waters, consider *Oasis*.



46' KELLY/PETERSON CC, '85 \$165,000
With the forefoot and area between the keel and rudder cut away for responsive maneuvering, she tracks well. Short overhangs are safe in high seas.



44' MASON - no teak decks, '90 \$188,500
Wine glass stern, pleasing overhangs, delightful sheer line. Bulwarks, dorades, opening ports; quality construction make her a modern offshore classic.



43' KETTENBURG, '65 \$29,500
Valentine is Hull 9 of the successful K43 design. She was sailed to Hawaii alone by Peggy Slater, and has won a number of races in Southern California.



38' HANS CHRISTIAN MK II, '79 \$79,000
Legendary cruising yachts built with class and quality. 38 Mark II is known for comfort w/2-strm Pullman berth layout; spacious shower forward.



38' MAXIM CUSTOM CAT, '00 \$180,000
Kattitude was custom built under the watchful eye of her experienced owner. She's one of those vessels that is extremely well equipped and maintained.



35' CARROLL MARINE 1D35, '00 \$75,000
With a PHRF of 30 flying an asymmetrical or 36 with stock spinnaker, she is tons of fun to sail. Going 20 knots downwind, she is still very manageable.



34' CATALINA, '89 \$29,000
Catalina 34 is regarded as one of Frank Butler's best designs for both pleasurable cruising and performance under sail. A must see in this size group.



32' SYNERGY 1000, '99 \$79,000
Needs nothing and shows great inside and out. Current owner was prepping to do Pac Cup '12, but plans changed. Don't miss out; turn-key program!



30' CATALINA, '83 \$21,900
Hey Jude is a feel-good boat from the moment you approach her. Shows exceptional loving care inside and out. For someone wanting to sail day of closing.



30' HUNTER 30T, '91 \$35,000
Strong sailing character enhanced by innovative bulb wing that balances good performance/stability with reduced draft. Step-thru transom with sugar scoop.



30' NEWPORT MK III, '83 \$21,500
Current owners have had *Happy Ours* since new; they want new owners to have as much fun with her as they had during their 28 years of ownership.

Custom Canvas & Interiors



The Gianola Family has been designing and fabricating custom canvas and interiors since 1969. Gianola Canvas Products offers you the best in quality, more choices, and personal service.



265-B Gate 5 Road
Sausalito, CA 94965
(415) 332-3339
www.gianolacanvas.com



**Marine Mechanical Repair
Electrical Repair & Upgrades
Installation Specialists
Full Service Shop**

BETA MARINE WEST

Engineered to be
serviced easily!

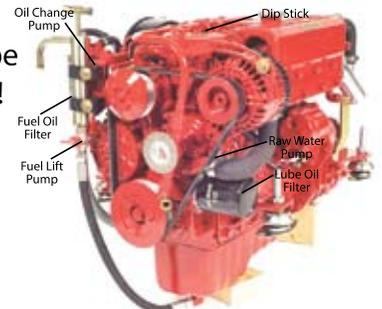

Dealer for Suzuki
Outboards

400 Harbor Drive, Sausalito, CA 94965
(415) 332-3507

www.betamarinewest.com
www.hirschfeldyacht.com

SCHOONMAKER POINT MARINA

• IN SAUSALITO •



160-Berth Marina in one of the most beautiful spots on the Bay



Visitor berths • Guest moorage up to 220 ft.
35-ft to 75-ft slips • Pumpouts • Marine services
Dry storage available • Three-ton hoist
Restaurant • Beach • Rowing • Kayaking

Sausalito's Finest Marina

85 LIBERTY SHIP WAY, #205
SAUSALITO, CA 94965

415•331•5550

FAX 415•331•8523

www.schoonmakermarina.com

LETTERS

sailors know, there are sets and lulls, both on the open ocean and when they break closer inshore. Leneman says the common misunderstanding is that these sets and lulls are caused by changes in the wind speed of the distant storms that create the waves. In reality, the sets and lulls are the result of two different wave trains intersecting each other. You get set waves when the energy of the waves in two trains combines, and you get lulls when the waves from two trains detract from each other.

Professor Leneman tells us that rogue or freak waves are not, as commonly thought, single waves travelling along in the ocean. "Rogue waves are created at the instant when a wave from one wave train overtakes a wave from another wave train, combining the force of the two. Because the overtaking



WEBB LOGG

We'll just follow the lead of the Dalai Lama, who said, "We all have to live together, so we might as well live together happily."

wave is traveling much faster than the wave train being overtaken, a rogue wave quickly disappears. When there is a rogue wave, it didn't exist 150 feet before or 150 after. Rogue waves are not common. You have to be in exactly the wrong place at exactly the wrong time to be hit by one."

So Tony, if you want to continue to contend that all other things being equal, the longer the wave period, the more dangerous the sailing conditions, we can only throw up our hands.

If anybody else has any oceanographic questions, particularly as they pertain to sailing, please send them to us, as Professor Leneman will be more than happy to answer them.

↑↓WHAT'S THE RUSH?

I just read your October 15 article on 'Time and Weather [in Mexico]'. My first sailing trip to Mexico was the Puerto Vallarta Race of February '77 aboard the Columbia 43 *La Mer*. Before taking off, I informed my college that I would be unavailable for a semester, then headed to sea. (Since then I've done two additional Ha-Ha's.)

We got rocked by heavy weather for a few days of that '77 race, then virtually drifted from Cabo to Puerto Vallarta. But it was the weather back home that was more interesting.

We had nothing but time on the return trip, so we left Puerto Vallarta and made our way to Cabo via Mazatlan. We waited and watched for a weather window in Cabo as other skippers left port in a hurry to do the Bash. A day or two later, they had all come back with torn sails and tired crew. Once boats stopped coming back, and we got radio reports that the conditions had smoothed out, we made our own run up the coast.

It was a great two weeks that we spent waiting in Cabo.

George Mann
Robin, C&C 35 Mk 3
San Francisco

George — Compared to today, weather forecasts were extremely primitive in '77, and they were hard to come by. Back then, you might have gotten a funky two-day weather forecast. If it looked good, you took off, and as likely as not got creamed a day or two later. It was hard on crew and boats.

These days folks who are about to Bash can luxuriate in Cabo, and can get good short- and long-range forecasts, en-

need glasses to read?

The Floater

Floats in the most turbulent conditions

Frame options: Tortoise Shell, Carbon Fiber & Grey
 Lens options: Polarized, Polarized Reader, Polarized Photochromic and Polarized Prescriptions available.



the Straddie

Polarized with non-polarized magnification
 Lens options: Grey or Amber
 +1.50, +2.00, +2.50



Barz Optics Australia
 Burleigh Heads, Qld
www.barzoptics.com
 61 755764365
kevin@barzoptics.com

Barz Optics
www.barzoptics.com

Barz Optics USA
 Murrays • Carpinteria, CA
www.murrays.com
 1-800-786-7245
steve@murrays.com

NEW - PC Polarized and PC Polarized Photochromic lenses (Melanin infused)

THIS YACHT MAINTAINED BY:

Stem To Stern

FOR ALL CONCERNS, PLEASE CALL:
(510) 681-3831

Responsibilities of the
In-port Captain

Yacht Security • Cruise Preparation
 Maintenance Scheduling • Delivery Services

- Hull Cleaning
- Washdowns
- Interior Cleaning
- Detailing
- Brightwork
- Mechanical Service and Repair
- Pump-Out
- Boat Yard Set-up and Management

Check out our website for a list of all our services at
www.StemtoSternSF.com
 or call (510) 681-3831

We Take the Work Out of Owning a Boat

WE HAVE OVER 170 BOATS FOR SALE

VISIT OUR WEBSITE:
www.mazmarine.com



TOLL-FREE

MAZATLAN:

1-855-892-2487 or 1-8558-YACHTS

LA PAZ:

1-855-225-2729 or 1-855-22-LAPAZ

SAN CARLOS:

1-855-846-7245 or 1-8558-GOSAIL

PUERTO VALLARTA:

1-855-789-2248 or 1-855-PVYACHT

❖ Season's Greetings ❖

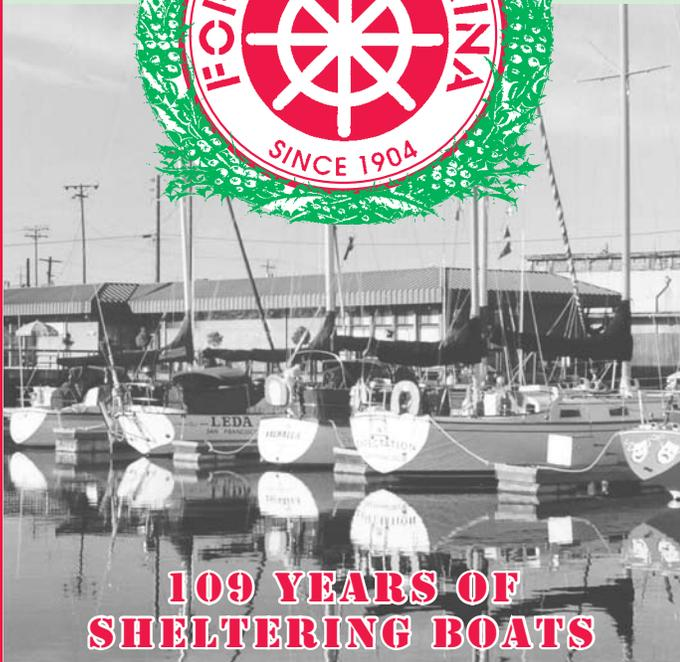

**109 YEARS OF
SHELTERING BOATS**

Celebrate the Holidays and the Whole Year at Fortman Marina

- Sheltered Alameda Location
- Competitive Rates
- Home of the Alameda Yacht Club

1535 Buena Vista Avenue
Alameda, California
(510) 522-9080



For directions and rates go to:
www.fortman.com

LETTERS

abling crews to plan when and where they want to be going up the coast. While weather forecasts are not perfect, if people have enough time, Bashes now often can be done in relatively mild conditions. This is one instance where technology has made life better and safer for sailors and boats.

⇓ **PLANNING A RETIREMENT CRUISE TO HAWAII?**

Does *Latitude* have any information as to who the oldest person is/was to have sailed singlehanded from the West Coast to the Hawaiian Islands?

D.C. Cooke
Seattle, WA

D.C. — Sorry, we don't. Why, what do you have in mind?

⇓ **MORE INTERESTING QUESTIONS**

Does anyone know if a Ranger 23 would be self-righting after a 180-degree knockdown? I think the issue of an 'ultimate righting equation' might be of interest to Lee Helm and *Latitude* readers.

Allan Wells
Berkeley

Allan — We're confident that Oakland's Gary Mull would not have designed the popular Ranger 23 to be anything other than self-righting, even from 180 degrees. But Lee Helm would have to give you the scientific evidence.

Why do you ask? Do you have something interesting in mind?

⇓ **MARY SHROYER PICKED ME UP WHEN I WAS DOWN**

Although we left California in '90, *Latitude* is still our favorite magazine for all the obvious reasons. Since we now visit the Golden State only twice a year, we keep informed by occasionally browsing *Lectronic*.

When scrolling through a recent edition, I saw only half of a photo before I recognized the person in it as Mary Shroyer of Marina de La Paz. I was struck nearly catatonic, and there's a story in it.

When we first headed north into the Sea of Cortez, we'd stayed at the Shroyer family's Marina de La Paz. Our next trip to La Paz was to be special, as my parents were flying



LATITUDE / RICHARD

Mary Shroyer, seen here with her son Neil, has helped many cruisers over the years.

down from Michigan. We would be staying at the marina, and also take them out to Partida for a few days of adventure. We arrived at the marina in plenty of time to settle into our berth and go to the airport to meet my parents.

While waiting for the plane, I was paged and instructed to go to the Mexicana Airlines desk. The manager took me into his office, cleared everyone else out, and handed me the phone. It was my father. My mother was in the hospital and had two weeks to live.

I am not certain how I got there, but the next thing I knew my wife and I were alone with Mary in her marina office, and she was walking us through all that had to be done for us to be on a plane to Michigan the next day. Back then, the paperwork to legally leave a boat in Mexico was voluminous and

RARE OPPORTUNITY!

Two 40-ft Covered Slips & a 62-ft Slip Available

LOCH LOMOND MARINA

Completely Rebuilt Marina • Gas & Diesel Fuel Dock • Free Pump Out Station
Modern Launch Ramp • Guest Slips Available • Marine Mechanical Boat Repair
Arena Marine Supply Store • Andy's Local Market • Bait Shop
Land or Sea Canvas • Windjammer Yacht Sales • Loch Lomond Yacht Club

110 Loch Lomond Drive, San Rafael, CA 94901

Phone: (415) 454-7228 • Fax: (415) 454-6154

www.lochlomondmarina.com

Harbor Master – Pat Lopez • pat@lochlomondmarina.com

Direct benefits

It's easy! With your new sail order from *North Sails Direct* you measure, you SAVE, you get the best. *Contact us today!*

FREE!
ONE YEAR
SAIL CARE
& REPAIR
with purchase of
a new North sail*

*Restrictions may apply. Ask your North Sails Direct representative for details.

NORTH SAILS
direct



northsailsdirect.com or call 888-424-7328

Boat size restrictions may apply.

GOLD COAST YACHTS U.S. VIRGIN ISLANDS

THE LEGEND
CONTINUES

106 CUSTOM
BUILT
MULTIHULLS



- Composite Yachts • Short Build Cycles
- Competitively Priced

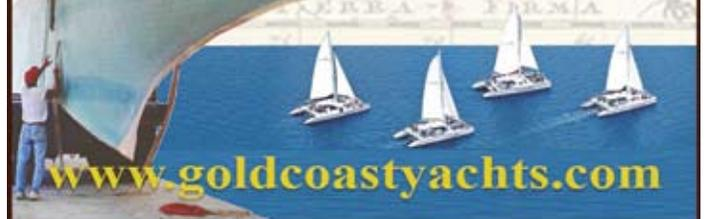

www.goldcoastyachts.com



West Marine® Rigging Service



Regardless of whether you own a traditional sailboat, offshore cruiser, club racer, high-tech dinghy or cutting edge racer, our master riggers are ready to help. And with easy ordering, guaranteed quality and fast service, it's no wonder that sailors everywhere increasingly turn to us for the rigging they need!



Extensive Inventory



Superb Quality!



Multiple Locations



Fast Service

GET YOUR ORDER STARTED TODAY!

888-447-RIGG

or visit our Onsite Rigging Locations in:

Alameda, CA San Diego, CA Seattle, WA

730 Buena Vista Ave. 1250 Rosecrans St. 1275 Westlake Ave. N

(510) 521-4865 (619) 255-8844 (206) 926-0361

SHOP WHAT EVERY BOATER NEEDS ONLINE!



Blocks

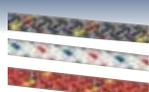

Line



Hardware



Anchoring

• Stay up to date, **READ OUR BLOG**

• Check out **CUSTOM RIGGING** at its finest

www.westmarine.com/rigging

LETTERS

obscure, but Mary walked us through it. She also arranged for someone to care for our boat cat while we were gone.

There are good people in this world and Mary is at the head of the class. When I was down, she picked me up.

I have debated sending this to you, as I'm afraid it would only encourage others to descend on Mary with their problems, large and small. However, if you are in contact with Mary, you might tell her that in '89, Joyce and Tom aboard *Rosie* were blessed by her kindness and are forever grateful.

Joyce & Tom Boynton
Traverse City, Michigan (summer)
Somewhere in the Bahamas (winter)
ex-*Rosie*, Nordic 40
ex-*Santana Catana* 411
Valentino, PDQ34 Powercat

Joyce and Tom — While the family-run Marina de La Paz is a for-profit enterprise, Mary, Mac and Neil have certainly gone beyond the call of duty to help countless cruisers over the years. They remind us of the famous Chinese proverb: "If you want happiness for an hour, take a nap. If you want happiness for a day, go sailing. If you want happiness for a year, inherit a fortune. If you want happiness for a lifetime, help somebody."

That said, the staffs of many other marinas in Mexico have also gone to great lengths to help customers over the years.

For those who weren't cruising Mexico in the '80s and even the '90s, it was technically illegal for boatowners to leave Mexico without their boats, putting people in a real bind in emergencies or if they wanted to go home for the holidays. The Mexican government instituted 20-year — now 10-year — Temporary Import Permits to solve this problem.

By the way, complete issues of Latitude 38 are available for download. And the photos look 10 times better than in print!

↑↓ FOND MEMORIES OF CLIPPER COVE

Having read about Editor LaDonna Bubak's experience anchoring in Clipper Cove during Fleet Week, I'd like to share an experience that my wife and I had in the late '80s.

We had anchored our '87 Morgan 41 *Okokok* about 50 yards off the beach in the middle of the cove, and took our inflatable ashore to enjoy a sunny afternoon on the beach. Shortly after we went ashore, we noticed a 45-ft powerboat trying to raise their anchor, but not having very much luck. We jumped into our inflatable and went out to see if we could help.

It turned out that the powerboat had hooked an anchor chain that had been left on the bottom for whatever reason. The links on this chain were heavy, very rusty — and at least 14 inches long! Their CQR had hooked dead center of one of the links, and the chain had to be fairly long because the crew could not get the mess up high enough to tilt the anchor to drop the chain.

I asked if I could help by resting the chain on the bow of our inflatable while they put the windlass in reverse. They agreed to try, and it worked. When the weight of the chain slid off the bow of our dinghy, we bounced up and down quite severely. The crew invited us for a drink at Richmond YC, but we respectfully declined and went back to the beach for more sun and a sundowner.

The moral of the story is that you never know what you will hook your anchor on when anchoring, even in a favorite location.

We sold our Morgan 41 in '09 and have dropped anchor in the Hill Country of Texas because of our physical inability to continue to operate the beloved boat that we owned for



INSURING YACHTS FOR OVER 50 YEARS

Providing Cruisers and Racers All Over the World
with Prompt, Reliable Service since 1959

Contact Us for a Quote

Exclusive
MARINERS Odyssey® Program
Mexico
South America
South Pacific
Caribbean
Mediterranean

Racing Sailboat Program
TransPac
Pacific Cup
PV / Cabo Races
Caribbean Regattas

www.marinersins.com

N. California
boomeins@aol.com
800-853-6504

L.A./Orange Co.
800-992-4443

San Diego
800-639-0002

Puerto Vallarta
52-322-297-6440

East Coast
Bradenton, FL
800-914-9928



QUALITY COVERAGE AVAILABLE IN MEXICO

Mariners Insurance Mexico offers insurance programs
for health, homes, autos, motorcycles and yachts in Mexico.

www.marinersmexico.com

Corporate Office: 206 Riverside Ave., Suite A, Newport Beach, CA 92663 / Ins. Lic. #0D36887

KISSINGER CANVAS

Marine Canvas & Interiors
STEVEN KISSINGER
(925) 825-6734
Covering the Entire Bay Area



- Biminis
- Boat Covers
- Cushions
- Sail Covers
- Headliners
- Awnings

DODGERS

Side handrails and window covers
included.

OPTIONS

Aft handrail, dodger cover,
sailing bimini.

Free Estimates and Delivery



**VALLEJO
MARINA**



Gateway to the Bay & Delta

The North Bay's Only Full-Service Marina!

- Slips starting at \$6.79 per foot!
- Concrete and Wood docks
- Covered berths available
- Night security guard



(707) 648-4370 • Fax (707) 648-4660

42 Harbor Way • Vallejo, CA 94590

www.ci.vallejo.ca.us marina@ci.vallejo.ca.us

Captain's License

Maritime  Institute

Captain's License Training

Maritime Institute has a course Near You!

From *San Rafael* to *San Diego*
or *On-line* at your own pace

- ✓ OUPV up to 100 GT
- ✓ Able Seaman
- ✓ Radar and Radar Renewal
- ✓ FCC License Exam - MROP
Marine Radio Operator Permit

Toll Free: 888-262-8020

www.MaritimeInstitute.com



America's Cup Harbor

San Diego's Newest Marina

On Shelter Island close to all amenities, from boat supplies to restaurants and markets.

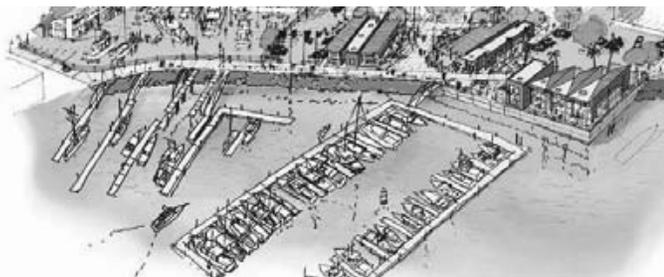

- Liveaboards * Deep Water Docks
- Slips for 30'-220' Yachts * 480v/3 Phase Available
- Free Wireless * Cox TV/Internet

www.IntrepidLanding.com

2700 Dickens St. | San Diego CA 92106 | P: 619-269-7300

LETTERS

23 years. After surviving numerous hurricanes, my wife also decided that a house inland was safer.

Greg & Arlene Davidson
Kyle, TX

Greg and Arlene — It comes as no surprise that someone might haul up big links from the bottom of Clipper Cove. After all, it's bounded on the north end by 400-acre Treasure Island, a man-made Works Progress Administration project that was completed in '39. One can just imagine the construction debris, which in those days was often just left on the bottom. In the '30s, Clipper Cove became the airport for Pan American Airlines Pacific Rim Service using the magnificent China Clipper Seaplanes. It was



LATITUDE / LADONNA

also the site of the '39-'40 World's Fair, and it's from Building One that Admiral Chester Nimitz directed the War in the Pacific.

The bottom line is lord only knows what stuff is still down there waiting to trap your anchor. You might even find something more modern. In a

It's rare to bring up such a prize after getting your anchor stuck in Clipper Cove.

previous trip to Clipper Cove, Bubak caught her 35-lb Bruce on a 45-lb stainless steel CQR and 100-feet of 3/8" chain that had obviously been cut free. Thankfully, the Treasure Island Development Authority has had all of the sunken boats removed, making it much less likely for anchors to get caught than it used to be.

↑↓ IN SEARCH OF NEW HOPE

I had a conversation with a certain boat designer about George Kiskaddon's 60-ft modern schooner *New World*, which was built in the early '70s. Talk drifted to *Great Hope*, the 24-ft prototype he built first. We were wondering if anyone knows the whereabouts of that boat.

John Amen
Diablo

John — Sorry, we don't know the whereabouts of Great Hope. Maybe a reader can help.

We do know where New World is — sprinkled in pieces on a reef somewhere in the South Pacific. As a racing boat, the narrow modern schooner New World never quite lived up to expectations. And after a number of years, Doug Wilde, an old friend, became the skipper, and ran her between islands in the South Pacific, carrying people — and sometimes even cattle on the hoof! When Doug decided to move on to Hong Kong, his replacement skipper didn't waste much time putting New World on a reef.

For those who don't know, Sausalito shipping magnate George Kiskaddon, who was before our time, was a very influential sailor on San Francisco Bay and beyond. In the '60s he had Sparkman & Stephens design Spirit, a 33-footer that was to be a family-friendly version of the Bird one-design class. Spirit proved to be a fine racer, and Kiskaddon eventually had a group of local sailors sail her across the Atlantic to England and around Europe. He was probably the first San Francisco sailor to do that. Spirit returned to San Francisco, where she saw great success in the hands of Sausalito sailmaker Pete Sutter and subsequent owners.

↑↓ SPARE TIME? WHAT'S THAT?

When you have some spare time, can you please try to



MODERN SAILING SCHOOL & CLUB

Sausalito, CA

www.ModernSailing.com

(415) 331-8250

**Get Your
US Coast Guard
Captain's License**

Feb. 26 - March 9

M-F, 9am - 5pm

OUPV LICENSE - \$995

100 TON LICENSE - \$1195

Our **GUARANTEED**, U.S. Coast Guard Approved course will prepare you for all elements of the exam, guide you through the application process, and conclude with on-site testing.



Holiday Sailing Package

GIVE THE GIFT OF SAILING

\$1095

- Basic Keelboat (ASA 101)**
- Basic Coastal Cruising (ASA 103)**
- Subscription to SAILING Magazine**
- One Year FREE Membership to ASA Club Initiation Fee**

**GO FROM TOTAL BEGINNER TO
CHARTERING SAILBOATS ON SF BAY!**

ALSO AVAILABLE - GIFT CERTIFICATES FOR
DAY TRIPS, CHARTERING, MEMBERSHIP, LESSONS



ASA OUTSTANDING SCHOOL 2009 & 2010



**Free
Two-Year
Extended
Warranty***



Mercury 9.9hp
ProKicker
sailboat motor



Mercury 4hp
dinghy motor

**on any new 2013 Mercury motor
purchased before December 22, 2012*

Outboard Motor Shop

(800) 726-2848

(510) 533-9290

All Prices INCLUDE freight & prep, plus tax & license only.

1926-2012
Your Bay Area Dealer
For 86 Years

333 Kennedy Street
Oakland, CA 94606

www.outboardmotorshop.com

**Season's
Greetings
and
Thank
You
for a
wonderful
2012**



**We couldn't continue without
your support and patronage.**

Best wishes for 2013!

SAL'S
INFLATABLE SERVICES, INC.

PHONE (510) 522-1824 FAX (510) 522-1064

1914 Stanford Street, Alameda, CA 94501

salsinflatables@sbcglobal.net • www.salsinflatableservices.com

TAG Heuer
AVANT-GARDES EYEWEAR

OFFICIAL PARTNER OF
ORACLE
TEAM
USA

363 America's Cup Defender

Alameda Eyes
OPTOMETRY

Proud Supplier of TAG Heuer™ Eyewear

- Advanced coatings repel sunscreen and water
- Lens color increases contrast helping you find the wind
- Polarization cuts glare

Our high-tech prescription helps you see the mark!

Sailing Spoken Here

1432 Park Street Alameda, CA 510-769-2020
www.alamedaeyes.com



LETTERS

find the date when a San Francisco newspaper printed the following: A Captain of a U.S. Navy sub was washed overboard while on the deck of the sub while the sub was surfaced and heading west under the Golden Gate."

I remember reading the headline when I used to live in Tiburon, from '73 to '76, and worked for Bechtel in San Francisco. I used to take the Red & White ferry from Tiburon to



US NAVY

the Ferry Building in San Francisco. In '73, it cost 50 cents each way.

I never read any follow-up stories on the sub skipper going overboard.

Commander A.L. Wilderman was "lost overside" from SSN-595, aka 'Plunger'

When I told the story to some ex-Navy and ex-Coast Guard friends down here, they said, "You must be losing it, Fred, we never heard that story."

I'm sure some *Latitude* readers will remember.

By the way, I sailed the East Coast and West Coast, and San Francisco Bay, aboard the Kenner 31 *Privateer*. I purchased her as a kit boat in '67, and launched her into the 'great south bay' — Long Island, New York — six months later.

P.S. Thanks for the excellent *Latitude* 38, which I pick up and read at the Oceanside YC.

Fred Engerer

Member of Paradise Cay YC, '73-'79

Fred — What is 'spare time'? That said, we can report that you're thinking of Commander A.L. Wilderman of the USS Plunger (SSN-595). He was "lost overside" in stormy conditions just off San Francisco on November 30, 1973. The 278-ft-long Plunger, which was decommissioned in '90, carried a complement of 130 officers and men.

Are you asking because the commanding officer of another submarine was lost just last month? We're referring to Chen Chi-tsung of the Taiwanese submarine Hai Lung, who was lost overboard in very rough weather in the waters off Taiwan.

↑↓ LIMERICKS ARE ENCOURAGED

It was fun to see my 'You Can't Sneak Poetry Past Us' letter published in the November *Latitude*, even if it was sans my poem. And thanks for the invitation to sail aboard *Profligate* on Banderas Bay this winter. I'm always up for a fun sail with interesting people, and promise to come bearing beer, not poetry.

Linda Dayoan
Richmond

Linda — We appreciate the beer offer, but it's more important to us that everyone who sails with us on Profligate contributes \$20 — directly, not through us — to his/her favorite charity.

On the editorial cultural front, we may have neglected to mention that, while we do not publish poetry, we do accept clever and humorous limericks. You know, stuff like "There was a sailing poet named Dayoan, who preferred to write with a crayon . . ." You can take it from there.

↑↓ RACIST PARROTS CAN BE DANGEROUS

I appreciate *Latitude's* *First-Timer's Guide to Cruising Mexico*. However, while skimming it I didn't see the issue of pets addressed.

McDERMOTT COSTA

insurance brokers - est. 1938

Commercial Operations

- COMMERCIAL POLICIES
- Marinas, Yards, Yacht Clubs, Brokers, Shipwrights

Pleasure Yachting

- YACHT & BOAT POLICIES
- Offshore, Coastal, Inland and Liveaboards

Lic. #OB21939

Bill Fowler
McDERMOTT COSTA INSURANCE
(510) 957-2012 Fax (510) 357-3230
bfowler@mcdermottcosta.com

EXCEL UNDER PRESSURE



When nerves are as taut as sheets it's reassuring to know that Doyle sails are taking the pressure.

Consistent wins in major events show that Doyle Stratis sails convert pressure into winning performance.

Whether you sail a skiff or a super-yacht, Doyle's latest generation of sails redefine performance sailing.



SPC 1045

Doyle San Francisco
Bill Colombo
510-523-9411

Doyle So. California
Bob Kettenhofen
949-645-5388

www.doylesails.com

COVER CRAFT

Tired of being

COLD AND WET?

Get some protection from wind and spray!

SAIL in COMFORT
with a dodger from Cover Craft



All sewing in Tenara thread.

- Classic dodgers and biminis
- Drop-top folding dodgers
- Custom canvas for sailboats

560 W. Cutting Blvd., #2
Richmond, CA 94804
Inside the KKMI boatyard

(510) 234-4400

Quality
Yacht
Canvas

NAPA VALLEY MARINA = SERVICE



- Engine repair – diesel and gas
- Shaft Alignment
- Outdrive repair
- Bottom Jobs –
- Gel Coat Repair
- AWLGRIP** Paints

WE CAN HAUL LARGE CATS/TRIMARANS

California's Largest Dry Storage Facility

NAPA VALLEY MARINA

1200 Milton Road • Napa, CA 94559
(707) 252-8011 • Fax (707) 252-0851

www.napavalleymarina.com

Marina • Boatyard • Chandlery • Brokerage

Dealers for
YANMAR

Interlux
yachtpaint.com

Distributors for *Brownell*
Boat Stands

SAUSALITO

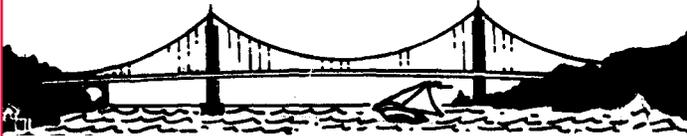

LIST MARINE INC.

- Full service engine shop
- We service all makes
- Dockside facilities
- Mobile service trucks



YANMAR
marine

P.O. BOX 2008 / 69 LIBERTY SHIP WAY • SAUSALITO, CA 94966
Adjacent to Schoonmaker Pt. Marina

415•332•5478

www.listmarine.com

Head North for the Holidays!

The latest sailing gear and accessories from North Sails.



NORTHgear
800-sail-123 ext. 653
www.northsails.com

LETTERS

Based on my experience, cruisers who own pets need to fully research the requirements — both for the U.S. and Mexico — before taking their pet south. This especially applies to cruisers with exotic pets, such as my African grey parrot. My bird is stuck in Mexico until I can finesse the permits needed to get him to the San Diego quarantine facility for 30 days, where he must prove to be free of infections.

Getting the permits for exotic pets is a road loaded with bureaucratic hurdles and lots of delays. Having the initial permit to exit the United States would make re-entry a little easier. The biggest problem is that four agencies — two U.S. and two Mexican — are involved in the process, none of them formally connected. Plus there are potential language barriers.

This issue needs to be more fully disclosed within the cruising community to prevent a boatload of heartache.

David Tamblyn
Quest, Morgan 33
San Diego / San Carlos

David — We don't cruise with a dog or cat, but it seems as if every other boat in Mexico has one, so apparently that's not a problem. Dogs in the South Pacific are another issue entirely.

When it comes to exotic pets, there are so many variables that it's up to each pet owner to do the research. But you're right, it can be difficult if not impossible.

We once had a parrot named Lola on our Ocean 71 Big O in the Caribbean, and even featured her on a Latitude cover. Having that bird was a lot of trouble, but not because of permits and quarantines. The problem was that some previous owner had taught Lola all kinds of racial insults. And trust us, when officials walk by your Med-tied boat at some island in the West Indies, the last thing you want is a loquacious, racist parrot.

↑↓ MYSTERY PANGA AT SEA

We read with interest your article discussing David Vann's writings about the death of John Long of Alameda a few years back and the possibility of pirates transporting drugs up the Pacific Coast to California in pangas powered by 115-hp outboards.

Several years ago, we were passengers returning to Los Angeles from Mazatlan on a cruise ship that was rerouted offshore to avoid a hurricane near Cabo San Lucas. Our new course took us about 150 miles farther out to sea than the usual shipping track. Having left the storm to starboard, we were enjoying a pleasant day at sea when an announcement from the bridge advised all passengers that we were altering course to assist a vessel apparently in distress.

The boat came into view as she bobbed in the 6- to 8-ft seas in light winds. As the ship slowly coasted up to her, we could see that she was about 40 feet long, had no cabin or deck of any kind, and was powered by two very large outboards. Her totally exposed cargo consisted of many rectangular plastic bags filled with brown material that were neatly stacked inside the hull.

One of the outboards was tilted out of the water, had its cover removed, and was being worked on by two intense young men who did not notice our arrival. Suddenly one looked up at the behemoth ship looming alongside and was clearly taken aback, as most of the 1,500+ passengers were hanging over the port side frantically snapping pictures. The other waved up at us, as he responded to the ship's crew, who had opened a large hatch near the waterline and were standing on the associated pilot-access deck.



*Wishing you a very
Happy Holiday
and Prosperous
New Year!*

Your friends at Owl Harbor



**OWL HARBOR MARINA –
LIKE NO OTHER.**

ISLETON, CALIFORNIA
OFF THE SAN JOAQUIN – CHANNEL MARKER 41

**STAY FOR A NIGHT, A MONTH,
A SEASON.**

916-777-6055

WWW.OWLHARBOR.COM

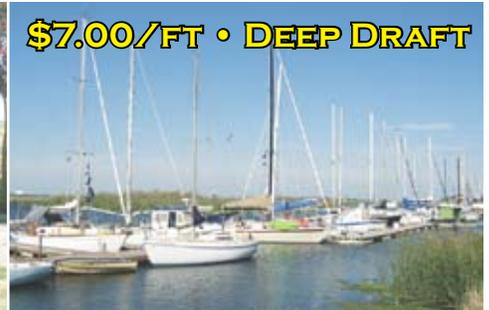

Ventura Harbor Boatyard

"For All Your Haul Out Needs"

**Two Travelifts
Haul Outs to 160 Tons
Full Line of Marine Services**

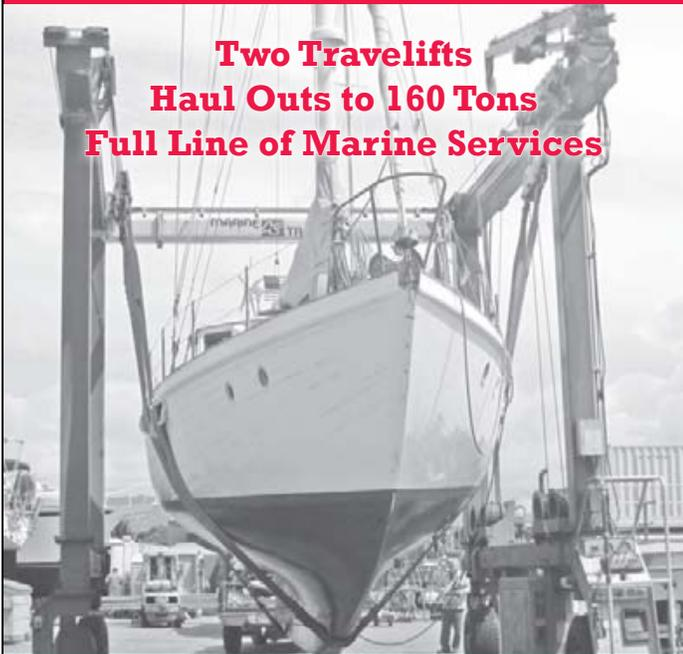

(805) 654-1433 www.vhby.com
1415 Spinnaker Drive Ventura CA 93001



McGinnis Insurance

Since 1972

**Agreed Value Policies
Year Round Mexico, Liveaboards,
Floating Homes**

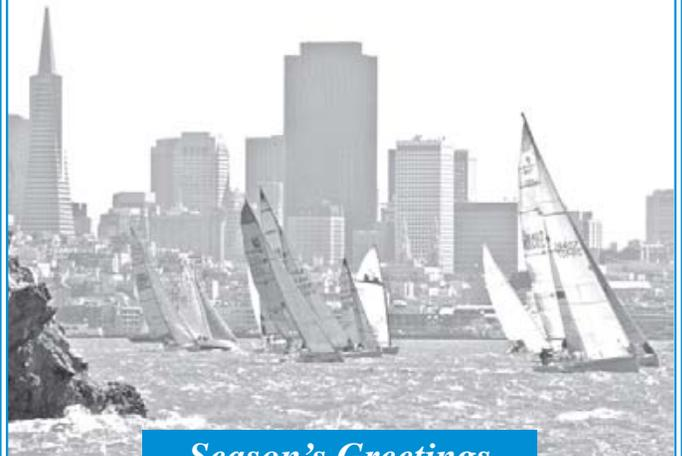

Season's Greetings

Call us at: 800-486-4008

mcginnisins@aol.com ☚ License #0570469

License #OE32738

TWIN RIVERS

MARINE INSURANCE
AGENCY, INC.

"Your Boat Insurance Specialists"

7 Marina Plaza • Antioch, CA 94509

At The Antioch Marina



Private Pleasure / Commercial Risks
Classic Yacht Programs

- West Coast
- Atlantic
- Mexico
- Hawaii
- East Coast
- Pacific
- Caribbean
- Alaska

Representing...



CHARTIS

TRAVELERS



ace seguros

ace recreational
marine insurance



Shop Your Renewal & \$ave • Flexible Survey Requirements

Insurance made simple, affordable and effective.

Broad Navigational Areas • Liveboards

Years of unbeatable experience to match your needs to the right product.

Agreed Value Policies • Fuel Spill Liability

Get an online quote: www.BoatInsuranceOnly.com

(800) 259-5701

LETTERS

After a brief discussion with our crew, the young men fired up the covered outboard motor, and the vessel lumbered off to the south in a cloud of blue smoke. Shortly thereafter, another announcement from the bridge advised the passengers that the men had requested some gasoline from the ship, but that none had been available. However, the officer noted that we were able to at least help by advising the Mexican Coast Guard of the boat's current position, course and speed.

To this day, we have no idea of the vessel's purpose at sea or its final destination.

Rick & Heather Reimer
Flying Scot, Ericson 30+
Monterey

Rick and Heather — Perhaps they were bringing hay to offshore sea horses.

But let's do some math. It's about 1,800 miles from Puerto Madero to the U.S. border. According to what we've gleaned from the Internet, 115-hp outboards get between two and five miles per gallon. Assuming that a very heavily laden 40-ft panga would get only two miles per gallon at the very best, that means it would take at least 900 gallons per engine, or 1,800 total, to make it to the border without refueling. Gas weighs about eight lbs a gallon, which would mean about seven tons of fuel. If the weather were anything but smooth, the fuel consumption could easily double. This leads us to believe that either these pangas don't go all the way to the border, or there are some unlicensed offshore Pemex stations.

↑↓ MAKING SENSE OF A TRAGEDY

I'm a beginner sailor — and a student at the Seattle Sailing Club at Shilshole Bay Marina — so please forgive my ignorance of what might be obvious.

Latitude's October *Changes* reported on the death of Dr. Ned Cabot, who died as a result of being washed overboard from his J/46 *Cielita* by a rogue wave off St. George's Bay, Newfoundland. He and friends were returning to Boston after a journey to Iceland and Greenland.

Since Dr. Cabot was a very experienced offshore sailor and described as being "careful and responsible," I'm interested in learning more to better understand how it happened, how it could have been prevented, and how he could have been rescued after going overboard.

Cabot's boat was reportedly hit by a rogue wave on the quarter and knocked down, tossing Cabot and the helmsman into the water. The latter managed to get back aboard, but the crew was unable to get a line to Cabot and he was swept away.

The force of the rogue wave is said to have broken a chain in the steering mechanism, leaving the remaining crew unable to steer the boat. Did the boat not have an emergency tiller? In addition, I've been taught that boats with fin keels — such as a J/46 — can be steered by using the foresail to push the bow and the main to push the transom. Maybe the boat couldn't have been steered very quickly, but couldn't the crew have turned the boat using the sails to steer?

How far was the boat off the coast of Newfoundland? Too far for communication by VHF or other radio to land, and too far for the timely arrival of a search and rescue asset?

How long was Dr. Cabot in the water? Here in the Pacific Northwest, where the water is frequently 53 degrees, it's said the average survival time in the water, with clothing, is 60 to 90 minutes. It seems that would have given a U.S. or Canadian helicopter a fair chance of getting to someone who is within 75 miles of the coast.



Serving the Bay Area
Since 1986

Seashine

Service of the Month

INTERIOR CLEANING

Keep your boat dry and mildew-free with our interior cleaning service. Remember to run a dehumidifier — with the cold temperatures, the boat's interior will stay moist for weeks!

ADDITIONAL SERVICES
Wash Down • Detailing • Maintenance
Polishing • Carpet & Cushion Cleaning

Fully Insured & Marina Approved
Call now for a Free Estimate

510 428-2522 or 415 457-6300
www.seashine.net

Think Fast!

Fast boats made to order...



Berkeley Marine Center

The yard that works for you!

In Berkeley Marina
510-843-8195

www.berkeleymarine.com



RICHARDSON BAY MARINA

formerly Kappas Marina

MODERN FACILITIES IN A WELL-PROTECTED HARBOR

Concrete Dock System

Well Maintained Facilities

Beautiful Surroundings

- DEEP WATER BERTHS: BASIN AND CHANNEL DREDGED
- CARD KEY SECURITY SYSTEM
- DOCK CARTS
- PUMP OUT STATION
- AMPLE PARKING
- CLEAN SHOWER AND TOILET FACILITIES
- WITHIN WALKING DISTANCE: MARKET/DELI, LAUNDROMAT, RESTAURANT
- AT EACH BERTH: LARGE STORAGE BOX, METERED ELECTRICITY, PHONE HOOKUPS, WATER

BERTH YOUR BOAT IN SAUSALITO

415 332-5510 www.richardsonbaymarina.com
100 Gate Six Road, Sausalito • Fax 415 332-5812

HANSEN RIGGING

510.521.7027

- Wire, Rod and Composite Standing Rigging built in-shop
- Quality Lifelines measured and installed
- Mainsheet systems that are easy to use
- Improved Jib and Main Boom Furlers sold and installed
- Running Rigging sold and spliced
- Halyards that do not Stretch
- Custom Masts and Booms built by Experienced Craftsmen.
- Boom Vangs, Reefing systems and Outhauls that work!
- Heavy Weather Preparation
- Proven Tuning Techniques
- Insurance Estimates
- Rig Inspections

NEW

DYNEEMA® BUNGEE

- Super elasticity
- Dyneema® cover

Only at Hansen Rigging

2307 Blanding Avenue, Suite G
Alameda, CA 94501

www.hansenrigging.com

Worst Nightmare.

Why compromise safety? Get an Ultra Anchor.



Ultra Anchor is certified by the American Bureau of Shipping (ABS) to meet their highest level of holding power for use on ABS class vessels. SHP certification is awarded to anchors with superior holding power of at least four times that of ordinary anchors.



Home of the Ultra Anchor



See us at upcoming boat shows

WorkBoat Show New Orleans, 12/5 - 12/7 • Toronto International Boat Show, 1/11 - 1/21
Seattle Boat Show, 1/25 - 2/3 • Fort Lauderdale Trawler Fest, 1/31 - 2/2

8700 Warner Ave. Suite #160 • Fountain Valley, CA 92708
www.ultraanchors.us • sales@quickline.us • 714 843-6964



BLUE WATER YACHT INSURANCE

Blue Water Yacht Insurance covers more active cruising boats than any other marine agency in the Western Hemisphere.

Our Insurance Programs Provide:

Crew of two anywhere • Worldwide Navigation
Charter Boats • Multihulls • Liveaboards • Racing Boats

Quality Rated Insurance Companies

Boats aged 1 to 40 years • "Agreed Value"
"All Risks" • "New for Old" replacement partial losses
Hulls valued \$50,000 to \$25,000,000

Worldwide Health Insurance

International and USA health insurance plans at affordable prices.



Call Toll Free (866) 463-0167

Fax (866) 795-3707

sales@bluewaterinsurance.com

Quote requests

Visit our website

www.bluewaterinsurance.com

LETTERS

Maybe I'm missing the obvious from lack of real sailing experience, but if I am ever thrust into that situation I'd like to know what doesn't work. As a quote from your 'Wisdom' section says, "Learn from the mistakes of others."

Before my first sail off Seattle, I equipped myself with a manual/automatic inflatable PFD, a water-activated strobe, and a floating, handheld VHF radio with GPS. Since I don't own a boat, I can't get an MMSI, but I can at least read my position off to SAR. I intend to get a PLB for the PFD before I take the boats out as skipper.

Sam Furgason
Seattle

Sam — You ask some very good specific questions, unfortunately many more than we have space to answer. In addition, we don't know the answer to a lot of specifics in the Cielita case, so we'll mostly stick to general remarks.

The most important thing to understand is that if you fall or are thrown overboard from a performance 46-footer — or just



COURTESY CABOT FAMILY

about any other boat — by a rogue wave when the wind is blowing 30 to 40 knots on a quarter, your odds of surviving — no matter what gear you bought and what training the crew has had — are probably no better than 50/50. If the boat you were on then lost steering for any more than a minute, you can probably reduce those odds by another 90%. If you go overboard in very cold water, you can probably reduce the chances by yet another 80%. If the crew on the boat is only moderately experienced, you can reduce the chances by another 90%. In other words, once Dr. Cabot

went overboard in those conditions, his chances of survival were all but nil.

If you do have to go overboard, make sure it's at night, you're wearing a personal strobe, the water is warm, and that the boat has steering and experienced crew. In such a case, your chances might be more like 75%

The bottom line is that you absolutely, positively can't allow yourself or anyone else on your boat to go overboard.

We don't think most sailors — even experienced ones — fully appreciate how fast a boat on a broad reach in gale force winds will leave an overboard victim behind. At eight knots, the separation is 810 feet per minute — well over the length of two football fields. The terrible truth is that nobody on the boat is going to be able to see the overboard victim for much more than a few seconds. The crew should throw all the man overboard stuff after the victim, of course, but it's quickly going to blow downwind of him, too.

The standard procedure for racing boats in a man overboard situation is an immediate round-up. The critical things are to absolutely minimize the separation between the boat and the person in the water, and to have one person do nothing but try to keep an eye on the person in the water.

It's possible to steer a boat without a rudder — in benign conditions. But it's not possible to sail a J/46 upwind in big seas and 35-knot winds. The other thing to consider is that the J/46's rudder was probably flopping all over the place, keeping the boat absolutely out of control until the emergency rudder was put on.

In even the best of situations, it's probably going to take at least a couple of minutes to get the emergency tiller in place.

The Cup is coming – slips are going!



Making boating easier – and more fun! – is what Oyster Cove is all about.

America's Cup boats are already here! Take advantage of Oyster Cove's great location. Near the races and practices, as well as SFO and mass transit, Oyster Cove is the private marina best for America's Cup convenience.

OYSTER COVE MARINA

385 OYSTER POINT BOULEVARD #8A,
SOUTH SAN FRANCISCO

(650) 952-5540

- Berths 30 feet to 60 feet
- Double Finger Concrete Slips
- Five Minutes from SFO
- Close to Mass Transit
- Heated Dressing Rooms & Showers
- Laundry Room
- Nightly Security Patrol
- Complimentary Ice

www.oystercovemarina.net



Check out our "Must-See" website!!

The Iverson's Dodger is now available in the Bay Area!

Dodgers • Bimini Tops • Enclosures

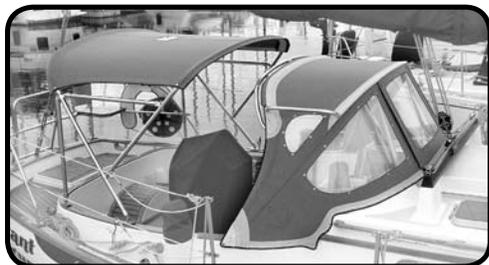

206-849-2274

www.iversonsdesign.com

SAN DIEGO'S RIGGING CENTER

since 1983



Proudly serving for over 25 years

Safe, cost effective, professional rigging solutions.

We'll get you ready for your next sailing adventure!

Design consulting • Commissioning
Refits • Custom line and hardware

WE SHIP RIGGING WORLDWIDE

619.226.1252

www.pacificoffshorerigging.com

LETTERS

And even when in place, many emergency tillers are nowhere near as efficient as regular tillers.

Cold water survival times vary wildly, depending on wind and sea conditions, the age of the person in the water, and so forth. Dr. Cabot was 69 years old, so neither his age nor the weather conditions were in his favor.

We don't know where Cielita was in relation to SAR assets, but please don't labor under the false impression that there are rescue helicopters stationed every 100 miles along the remote coasts, and that rescue teams are standing by 24/7 ready to jump into them at a moment's notice. When you go offshore, you should make the assumption that you are alone. It may not be true, but you should operate as though it were.

From time to time, man overboard seminars are held in popular sailing areas. Those who participate are usually surprised by how difficult it is to find and rescue an overboard crewmember in even benign conditions. And getting a line to such victims is just half of the battle, as getting that victim back on the boat is often as difficult, if not more difficult.

We've said it once, and we'll say it again — you can't let yourself or any member of your crew go overboard. In most cases it's a death sentence.

↑↓WHEN RRS AND COLREGS COLLIDE

Related to the 'Your Right of Way Was Wrong' letter in the October issue, there is a point of the right-of-way rules of which I believe very few racing sailors are aware.

Some years ago, an unnamed yacht club in the South Bay ran a race for which the Sailing Instructions failed to invoke the Racing Rules of Sailing (RRS). During the race, an overtaking boat was passing to leeward of another, slower boat. After establishing an overlap, giving them rights under the Racing Rules of Sailing, the leeward boat headed up to what they felt was their proper course. The weather boat did not alter course and failed to keep clear. During the ensuing crunch a crewmember was seriously injured.

When the resulting lawsuit went to court, it was determined that since the Racing Rules of Sailing had not been in effect because they hadn't been invoked in the Sailing Instructions, the race was *de facto* being run under the COLREGS.

In the COLREGS, unlike the Racing Rules of Sailing, an overtaking boat has no 'leeward boat' rights after establishing an overlap. There is no counterpart to RRS 11 in the COLREGS. The overtaking boat always remains the burdened boat until she is clear ahead. So in this case, without the RRS being in effect, the leeward boat ended up being responsible for the injury.

Bartz Schneider
Expeditious, Express 37
San Francisco

Readers — A very experienced racer who has won the Express 37 division of the St. Francis YC's Rolex Big Boat Series with his Expeditious several times, Bartz knows what he's talking about.

In a typical month, we receive a tremendous volume of letters. So if yours hasn't appeared, don't give up hope.

We welcome all letters that are of interest to sailors. Please include your name, your boat's name, hailing port and, if possible, a way to contact you for clarifications.

By far the best way to send letters is to email them to richard@latitude38.com. You can also mail them to 15 Locust, Mill Valley, CA, 94941, or fax them to (415) 383-5816.

WE WANT YOUR BOAT LOAN



NORTHERN CALIFORNIA REPRESENTATIVE
Bill Kinstler
866-486-2628

WEST COAST REPRESENTATIVE
Max Salvater
888-898-2476



HIT THE WATER WITH A GREAT RATE!
RATES AS LOW AS
4.25%
APR

Visit us at...
www.boatbanker.com



MARINE INSURANCE SPECIALISTS

Your best source for Yacht and Boat Insurance tailored to your needs and competitively priced

We Insure:
Sail or Power ♦ Classic or Contemporary
Fiberglass ♦ Aluminum ♦ Steel ♦ Wood

At Heritage Marine Insurance you will find knowledgeable insurance professionals who provide superior service and the finest coverage available today.

To be sure you're getting the best insurance value please contact us for a quote.

www.heritagemarineinsurance.com
800-959-3047
Fax 860-572-5919
classics@heritagemarineinsurance.com

Program available exclusively through:



BoatSmith

Precision Marine Carpentry
Fiberglass Catamaran Builders

561.632.2628
BoatSmithFL.com



We Build Your Dreams

THE BRANDS YOU WANT AND TRUST IN STOCK FOR LESS!



Norcolder 4408 Series Icebox Conversion Kit

Item 401278

\$724⁹⁹



- Redesigned Configuration
- Lower Amp Draw
- Refrigerates Areas up to 6 Cubic Feet

Most Orders Placed by 4pm Ship the Same Day!
No Sales Tax on Orders Shipped Outside of Connecticut!

Defender

www.defender.com

800-628-8225

FREE Catalog!



ULTRA SMALL CABIN AND WATER HEATER

DEPENDABLE COMFORT

Be comfortable all year round with a quiet, reliable Webasto hot water heating system. Can be linked to pre-heat an engine and provide all the hot water you'll need in the galley or for showers.

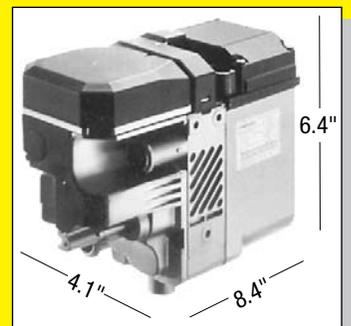

Webasto

CERAMIC IGNITION SYSTEM

- Heat output 17,200 btu/hr (5kw)
- Fuel Consumption .18 gal/hr
- Power Consumption 32 w
- Weight 6.4 lbs

CALL FOR
MORE
INFORMATION



SWEDISH MARINE

1150 BRICKYARD COVE RD., SUITE B6
PT. RICHMOND, CA 94801 (510) 234-9566

vendée globe starts with a bang

The toughest sailing race on the planet, the Vendée Globe, started on November 10 in Les Sables d'Olonne, France. Known as the 'Everest of the Seas', the quadrennial race — now in its seventh edition — takes solo skippers on IMOCA 60s around the world nonstop. Twenty courageous skippers — 19 men and one woman — took the challenge.

Though it was cold and rainy the morning of the start, more than 300,000 passionate fans lined the famed French harbor's channel walls to cheer on the fleet as the boats made their way to the starting line. The French love sailing as much as Americans love NASCAR, and with the carnage suffered during the first 10 days of the race (at which point this issue went to press), we're certain Brad Keselowski fans would enjoy it just as much as watching cars go around and around a track.



ARMEL LE CLÉAC'H / BANQUE POPULAIRE

Armel Le Cléac'h.

As of this writing, a full 25% of the fleet had retired with damage and a six-boat pack was match racing toward the equator to lead the race. Just 50 miles into the 24,048-mile race, *Safran* suffered a keel failure while leading the fleet across the Bay of Biscay. Skipper Marc Guillemot sailed precariously back to port — his race was over before it had started. Prodigy François Gabart, 29, aboard *MACIF* wasted no time in taking Guillemot's lead position as the fleet endured their first 300-mile speed test to Cape Finisterre.

Once the fleet rounded Finisterre and was running downwind along the coasts of Spain and Portugal, disaster struck again. First it was Kito de Pavant on *Groupe Bel* who struck a fishing trawler at speed. With a massive hole in his port side, he cautiously sailed to port in Cascais, Portugal.

Next, the fleet's youngest sailor, Louis Burton, 27, took a glancing blow off a trawler at some 18 knots of speed, damaging *Bureau Vallée's* port cap shroud. Attempting to sail back 600 miles to the starting line to fix his yacht and restart by the November 20 start deadline proved futile. A gale struck the Bay of Biscay and forced him to port in Spain to protect his damaged mast. His race was over as well.

In what is undoubtedly the biggest headline of the race so far, the fleet's most popular — and only female — sailor, Samantha Davies, dismasted west of Madeira. While preparing to tuck a third reef in her mainsail, *Savéol* launched off a wave while beam reaching in a 40-knot squall. Immediately upon landing, her 90-ft-tall carbon fiber mast came crashing down.

And if all of that weren't enough, the Open 60 that won the last Vendée Globe, *Maître CoQ*, had to retire to the Cape Verde Islands with a hydraulic keel-jack failure. Skipper Jérémie Beyou could no longer sail his boat, as his canting keel would swing freely to leeward, seriously crippling the yacht's performance.

Aside from the damage, the race for the lead has been a breathtaking one since the starting gun. Arguably the two most talented skippers in the fleet, Armel Le Cléac'h — aka 'The Jackal' — on *Banque Populaire* and Gabart on *MACIF* have been match-racing each other since the start, with the young pair swapping the lead multiple times on their ultra-fast, cutting-edge VPLP-designed sisterships. Now approaching the equator, the dynamic duo are leading a six-boat pack that has been compressed by the dreaded doldrums, or ITCZ, and its characteristic light and variable winds. Rounding out this lead pack are Barcelona World Race champion Jean-Pierre Dick (*Virbac Paprec 3*), Switzerland's Bernard Stamm (*Cheminées Poujoulat*), England's Alex Thomson (*Hugo Boss*), and '04-'05 Vendée winner Vincent Riou (*PRB*).

Less than 300 miles behind, three multi-Vendée veterans — Briton Mike Golding (*Gamesa*), Frenchman Jean Le Cam (*SynerCiel*) and Swiss skipper Dominique Wavre (*Mirabaud*) are drag racing south at

continued on outside column of next sightings page

classy classifieds'

Latitude's Classy Classifieds are an institution. For the last 30-something years, eager sellers have known that an inexpensive *Classy* ad generates more quality — and qualified — leads than any other source. It's often the first section of the magazine readers turn to. And now that *Classies* are added to our website at no additional charge, sellers are exposed to even more potential buyers.

On the 18th of every month, we get phone calls, emails and folks dropping in to place their *Classy* ad. But starting



SAM DAVIES / SAVEOL

You can't keep Sam Davies down. After dismasting on November 15, she set up a jury rig for 'Savéol' with a donated Laser sail and part of a mast to sail back to France. What a woman!

NEWS FLASH! Just as this issue was being sent to the printers, Polish skipper Zbigniew 'Gutek' Gutkowski on 'Energia' retired after failing to fix his autopilot problems. "Being brave is not only about fighting," he said. "It is also about knowing where to stop."



new deadline

with the January issue, those wanting to place an ad had better mark their calendars three days earlier because the new deadline for *Classies* is the 15th of every month (even if that falls on a weekend).

Placing a *Classy* is simple. Just pop on over to www.latitude38.com and click on 'Classy Classifieds'. Forty-word ads are still just \$40 and will go online quickly, as well as in the next month's issue of the magazine. If your boat is priced at under \$1,000, an online ad is free!

— *ladonna*

vendée — cont'd

close to twenty knots in tight formation, desperately trying to stay in touch with the lead pack. Another 400 miles back, a three-boat pack has formed with Spain's Javier "Bubi" Sansó (*Acciona 100% EcoPowered*), France's Tanguy de Lamotte (*Initiatives-coeur*) and Bertrand de Broc (*Votre Nom Autour du Monde*), who was forced to re-start the race 14 hours late after damaging his bow when sailing to the start line.

Over the next month, the fleet will continue sailing south, carefully negotiating the Saint Helena High before turning east at South Africa's Cape of Good Hope and racing across the Southern Ocean at speeds exceeding 30 knots, constantly watching for Antarctic gales and floating icebergs. We'll keep you up-to-date on the action in *Electronic Latitude*, or you can follow the race at www.vendeeeglobe.org/en.

— *ronnie simpson*



"Good luck! You let us dream!!"

LLOYD IMAGES / DPPI / VENDEE GLOBE



KITO DE PAVANT / GROUPE BEL

For the second running of the race in a row, Kito de Pavant had to withdraw shortly after the start. This time 'Groupe Bel' collided with a fishing trawler.



SPREAD VINCENT CURUTCHET / DPPI / SAVEOL

SIGHTINGS

bounty* claimed by hurricane *sandy

After Hurricane *Sandy* claimed 91 lives in the Caribbean, she set her sights on the East Coast and, in the end, caused an estimated \$54 billion in damage and took an additional 133 lives. Two of the earliest American victims were Captain Robin Walbridge, 63, and Claudene Christian, 42, who were washed off the 180-ft, three-masted replica of the original HMS *Bounty*. Christian's body was recovered hours after the remaining 14 crewmembers were rescued by Coast Guard helos, but Walbridge was never found.

Bounty, a full-rigged ship, was built in 1960 for the Marlon Brando film *Mutiny on the Bounty*. Though she was destined to be a film set, she was built to the highest standards in Lunenburg, Nova Scotia, to the original HMS *Bounty*'s drawings — her length was doubled and tonnage increased — using traditional methods. She was also featured in two *Pirates of the Caribbean* films: *Dead Man's Chest* and

continued on outside column of next sightings page

eight bells for

The Bay Area lost a sailing pioneer last month. Donald Durant (Sr.) passed away surrounded by family at his home in Carmel on November 11.

Donald Durant, husband to Betty Jane and father to Don, was born and raised in Oakland, and lived most of his life there. After dabbling in powerboats, he and Betty fell in love with sailing in the mid '50s. It wasn't long before Donald got interested in racing, and not long after that, he established the Metropolitan YC at Oakland Marina, serving as the club's first commodore.

In the late '50s, Donald was introduced



SPREAD: USCG / BRANDYN HILL; INSET: MICHEL GOSSELIN

donald durant

to a lovely 30-ft Norwegian woodie called a Knarr. He and Betty believed the boat's stout design would be well suited to the Bay's feisty conditions, so he imported hull #74 to test his theory. He was right.

Donald and some yacht club friends began importing Knarrs under their newly formed company Nordic Yacht Imports to build a new one design class. Anyone who races on the Bay can tell you that they were successful — it remains one of the most popular classes today.

Donald's company later changed its name to Sailboats, Inc. and grew to become

continued in middle column of next sightings page

bounty — cont'd

At World's End. The ship underwent a \$3 million refit in '07, and had been in drydock for maintenance shortly before their departure.

Under Walbridge's command — he'd served as her captain for 17 years — *Bounty* left New London, Connecticut, on October 25 bound for her winter home in St. Petersburg, Florida. Late on October 28, Walbridge called the owners to report the ship had lost power and the crew were unable to keep up with the inflow of water. At 4:30 a.m. on October 29, he ordered the crew to don survival suits and abandon ship to two liferafts, and activated the ship's EPIRB.

Later, the crew reported that, as they were entering the rafts, *Bounty* fell onto her side, sending at least three crewmembers into the water. The first mate, John Svendsen, managed to swim to a floating beacon Walbridge had designed, but Capt. Walbridge and Christian — the ship's newest crewmember and the great-great-granddaughter of the original *Bounty* mutineer Fletcher Christian — didn't make it. The Coast Guard arrived to effect the very dangerous and successful rescue of 14 lives a few hours later.

That *Bounty* took to sea in the face of the massively broad and well-forecast storm is controversial to say the least. Rather than stay in port, the decision was made — presumably by Walbridge — to set sail. "Rest assured that the *Bounty* is safe and in very capable hands," was the message that appeared on *Bounty's* Facebook page. "*Bounty's* current voyage is a calculated decision . . . NOT AT ALL . . . irresponsible or with a lack of foresight as some have suggested. The fact of the matter is . . . A SHIP IS SAFER AT SEA THAN IN PORT!"

Three days later that opinion was proven false, as *Bounty* put out a distress call while 90 miles off Cape Hatteras and 160 miles from the center of *Sandy*. Two hours later radio contact was lost with the vessel.

There has been speculation on the Internet that a lack of finances necessary to keep *Bounty* in top condition might have been a contributing factor to her loss. But crewmembers have since come forward to say the ship was in "great shape," and that they considered Walbridge to be a safe and outstanding captain. "I [owe] my life to Robin, and to his ingenuity, to his leadership, that I'm here today," said Svendsen.

Though she was the greenest crewmember, Christian was well-liked by her mates, if for nothing more than her excitement at being aboard. "She was having the time of her life," said one in an ABC interview. The point was driven home in her final text to her mother: "And just be sure that I am ok and happy to be here on *Bounty* doing what I love . . . if I do go down with the ship and the worst happens . . . just know that I am truly genuinely happy! And I am doing what I love."

— ladonna



COURTESY BOUNTY

Claudene Christian was swept off 'Bounty' as it was sinking.



'Bounty', the replica of the original HMS 'Bounty', sank 90 miles off Cape Hatteras during Hurricane 'Sandy'.

america's cup update

It's a bird. . . It's a plane. . . No, it's Artemis Racing's sleek new AC72 testing the waters of San Francisco Bay. In mid-November, the bright-red speed machine completed two test sails in moderate wind conditions — at some points flying a hull with no apparent difficulties. No doubt the problem-free sessions were a relief to team members after suffering damage to the wing sail on the boat's first outing, followed by structural problems with the platform last month.

Meanwhile, behind the scenes, Oracle Team USA staffers are working to replace their 72's wing mast, which was destroyed by wind and waves after the big cat capsized last month, and was washed out the

continued on outside column of next sightings page

SIGHTINGS

ac — cont'd

Golden Gate before she could be righted.

Just days after Artemis' first test sail, America's Cup history was made again; this time on New Zealand's Hauraki Gulf when Emirates Team New Zealand and Luna Rossa met up for a friendly practice and testing session. It was the first time that two AC72s had been on the water at the same time — ever! The breeze never got above 12 knots, so the pair of cats didn't get to truly show their enormous

speed potential, but the awe-inspiring scene of two giant wing-sailed cats doing battle was impressive, nonetheless.

Switching back to America's Cup action on our home waters of San Francisco Bay, the Red Bull Youth America's Cup trials began last week at Pier 80 in San Francisco. The Bay Area's own 'American Youth Sailing Force' began the trials last Monday, becoming the first all-youth-

run and -operated team to go sailing on an AC45. After a quick lesson in rigging the wing-sailed cats and a morning briefing, AYSF sailed laps around the South Bay with Oracle Team USA skipper Darren Bundock acting as their coach and mentor. De-rigging the boats and reviewing footage from the day's sailing session, the six young sailors were physically wiped after two hours of intense practice.

The next morning, they endured physical fitness tests, which included grinding on a mock pedestal for five minutes straight and even grinding a winch connected to a heavily weighted tractor tire! After the demanding tests, the sailors, ages 19-24, went out on their second and final AC45 test sail of the week. Getting a tow to the top of the Berkeley Circle, the team sailed their Red Bull AC45 in laps around channel markers before AC race management set up a mock race course for them to run.

The trial wasn't timed, but the team pushed their hardest and "even John Craig from the AC Race Management seemed impressed," said jubilant AYSF skipper Ian Andrews. "I was probably more timid than normal doing the first bear-away, jibe and tack, but I got more aggressive on the helm. It wasn't as daunting as I thought it would be and I feel confident in our team and what we can do."

With the international selection series beginning in February 2013, this round of trials was to choose a team to represent the U.S. and a team to represent San Francisco in the Red Bull Youth America's Cup, which has been added to next summer's America's Cup schedule of racing. According to organizers, the event "opens the door for young sailors to gain the experience they need to contribute to a Cup team." In all, six teams will be tested in competition for these two coveted spots.

— ronnie simpson (with latitude/andy)

building on time-honored traditions

Just a stone's throw from the Sausalito waterfront, the keel will soon be laid for a very large boat — a ship actually. In fact, it may be the largest vessel built in that famous maritime town since the massive ship-building boom of World War II. This 140-ft (LOA) vessel will not make war, however. On the contrary, she will be a *bona fide* wooden tall ship, whose purpose is to promote good will and maritime education. The visionary sailors behind the project hope she will be

continued on outside column of next sightings page

durant

the largest Columbia dealership in the country. Throughout the years, it changed names several times — Nor Cal Yachts, Cruising Specialists, H&S Yacht Sales — and is now known as Cruising Yachts, the largest sailboat dealer in the state. It also spawned a little sailing school and club you might know: Club Nautique.

In addition to his sailing-related endeavors, Donald was also responsible for the development of Oakland's Embarcadero Cove, a marina and real estate project inside Coast Guard Island on the Estuary. If you've ever stopped at Quinn's

GUILLAIN GRENIER / TEAM ORACLE USA



The young sailors who make up the American Youth Sailing Force had a great time sailing on the Red Bull AC45.



CHRIS CAMERON

ETNZ's big cat has also been launched, and is currently testing in Hauraki Gulf. She clocked 43.6 knots recently in 25 knots of wind!



— cont'd

Lighthouse after a long daysail, you can raise your next frosty beverage to Donald. He purchased the building, which had originally been located at the entrance of the Estuary, from the Coast Guard for \$1, moved it and had it restored.

Donald epitomized 'The Greatest Generation' as a man who grew up during the Depression, served in the Navy from 1940 through the duration of WWII, and believed he could accomplish anything he set his mind to, often with minimal resources other than his conviction and hard work. He will be missed.

tall ship — cont'd

regarded as *the* San Francisco Bay tall ship, and will eventually represent the Bay Area both locally and at tall ship festivals along the West Coast and perhaps beyond.

As we pointed out in our February report, despite the fact that the San Francisco Bay region's colorful nautical heritage is intrinsically linked to the great Age of Sail, not a single brig, barque, or brigantine is currently based here. At the time of that earlier story, the game plan for construction had already been sussed out, detailed plans had been drawn, and more than a million dollars had already been raised to begin the project. The hang-up for months, though, has been finalizing a build site. But today we're pleased to report that an ideal site has been established — thanks to the generosity of Skip Berg — just inland from Sausalito's Marina Plaza, and not far from

continued on outside column of next sightings page



Sweden's Consul General Barbro Osher — the 'Godmother of Artemis' — gets a helping hand from CEO Paul Cayard while christening the AC72.

SIGHTINGS

tall ship — cont'd

the Bay Model and Army Corps of Engineers facility, from which, we assume, the brigantine will be launched sometime in 2014.

Inspiration for the shape, lines and rig of this vessel come from the innovative designs of Matthew Turner, a prolific late-19th century shipbuilder whose merchant vessels were faster and sleeker than any that had come before. This new ship, whose working name is simply the Educational Tall Ship (ETS), will be a scaled-down version of Turner's famous *Galilee*, and will be built using old-style methods, yet with many new-age adaptations.

All the lumber, for example, will come from sustainably harvested Pacific Coast forests. If all goes as planned, the ship will employ a

continued on outside column of next sightings page

holiday shopping

There's no two ways about it, holiday shopping sucks. So instead of fighting the crowds at the mall this year, go the lazy route and hop on over to Amazon to order sailing books for the various people on your list. We receive dozens of review copies of sailing (and frequently non-sailing) books throughout the year. We save them up in hopes of bringing you a list of the more interesting ones in the December issue. Sometimes we have the space, sometimes we don't. This year



Socrates says it was nice to speak to people face to face one more time before heading the rest of the way around the world alone.



for sailors

there are too many good ones to not share. We haven't read all of these books, but they've at least piqued our interest.

First we'll start with the more hands-on selections:

- *Cornell's Ocean Atlas: Pilot Charts for All Oceans of the World*, Jimmy Cornell, \$99.95 — Sailing icon Jimmy Cornell released this new atlas of 129 pilot charts based on the most recent weather data. It features sixty monthly charts with wind

continued in middle column of next sightings page



Socrates could receive all the verbal assistance she needed, but she had to do all the work herself and with her own tools.



"Put your back into it, Jeanne!"

tall ship — cont'd

hybrid design, in which her auxiliary propulsion and onboard energy needs will be met by 'regenerative power'. That is, instead of diesel engines, ETS will be propelled by DC electric motors (connected directly to the prop shafts) which will draw their energy from large battery banks. Here's where the 'regeneration' concept comes in: While under sail, the free-wheeling rotation of the propellers caused by water flowing across them will make the motors function as generators, thus recharging the battery banks. Although it may sound far-fetched, such systems have proven amazingly effective elsewhere. The goal, in keeping with the vessel's environmentally focused educational programs, is for ETS to operate carbon free. (Dockside charging from solar panels and wind generators will help in that effort.)



This Turner-inspired design will be fast and graceful, with a narrow bow and displacement well aft.

The ETS project is the brainchild of widely respected schooner man Alan Olson, who launched the Call of the Sea educational program in recent years, with the schooner *Seaward* as its flagship. To ensure a world-class design and build plan, Olson and his associates contracted naval architect Andy Davis of Tri-Coastal Marine, considered one of the world's preeminent design firms for historic vessels.

Construction will start next month, and we can hardly wait.

— andy

socrates makes pit stop in the bay

It's unusual for someone who's attempting to set a nonstop solo circumnavigation record to make a pit stop along the way, but that's just what Brit Jeanne Socrates did in early November. Socrates, who set off from Victoria, BC, on October 22 on her third attempt at a nonstop trip around, was off the Oregon coast just a few days after her departure when she noticed that her speed had gone from a solid six knots to three. She popped her head up to find that her liferaft had slid right out of its mount and into the sea, instantly inflating and acting as a very efficient drogue for her Najad 380 *Nereida*. She had little choice but to cut it free.

After notifying the Coast Guard of the unmanned liferaft, she contacted the World Speed Sailing Record Council — the organization that will ratify her record — for advice. She had no interest in continuing such an arduous journey without a such an important piece of emergency equipment but she didn't want to abandon her attempt, especially so soon after the start. Thankfully the WSSRC agreed and gave her explicit instructions on how she could and could not effect the replacement of the raft. A boat could tie up to her and pass her the equipment but no tools could be offered and no one could come aboard.

In the wee hours of November 1, Socrates took advantage of a flood current to take a buoy generously offered by Sausalito YC. Sausalito diver Tim Sell had set up a can't-miss retrieval system so she could not only spot it in the dark, but could easily pull it aboard. Then this writer, her husband, Sal Sanchez of Sal's Inflatables and Sell converged on *Nereida* the following afternoon to hand off her new raft.

It's difficult enough mounting a raft on a stern rail while at

continued on outside column of next sightings page

socrates — cont'd

anchor but when a 69-year-old woman who weighs about as much as a wet Yorkie must do so completely unassisted, folks get creative. It wasn't easy and it wasn't quick but eventually Socrates — with lots of advice from the boys — was able to fit the raft into its mount and secure it.

Socrates had hoped to take advantage of the ebb current that night but light winds forced her to anchor just outside Richardson Bay for the weekend. Several Bay Area sailors dropped by to say hello, which cheered her immensely. "Two offered bottles of wine, which I couldn't accept, unfortunately, but the face-to-face chats were nice because they were the last I'll have before I get back," she said.

Nereida was finally able to weigh anchor on November 5, drifting out the Gate on zephyrs. The wind played cat and mouse with Socrates until she hit Mexico, where it finally stabilized enough for her to make consistent speeds toward Cape Horn. With her delayed departure, followed by her pit stop in the Bay, *Nereida* can't afford to lose any more time getting to Cape Horn, but as this issue went to press, she was nearing the ITCZ, and it's not known for brisk breezes. Follow her trip at www.sunereida.com.

— ladonna

us sailing's aegean final report

West Coast sailors were delivered a one-two punch this spring when two tragic accidents just two weeks apart took a total of nine lives. First, *Low Speed Chase* went ashore at the Farallones on April 14 during the Full Crew Farallones Race, killing five of the eight crewmembers. Then on April 28, the Hunter 376 *Aegean* ran into North Coronado Island during the Newport to Ensenada race, taking all four crewmembers. US Sailing's report on the LSC incident was released in early August, while *Aegean's* was released on October 30.

As predicted, the investigative panel — which included West

Coast sailors Bruce Brown (chairman) and Alan Andrews, and special consultants such as Evans Starzinger and Chuck Hawley — found that "a key element of the accident was likely an inadequate lookout, and that it is likely that *Aegean* inadvertently motored beyond a waypoint set before North Coronado Island." Three of the victims — owner/skipper

Theo Mavromatis, 49, Kevin Rudolph, 53, and William Johnson, 57 — died of blunt force trauma, while Mavromatis' brother-in-law Joe Stewart, 64, died of drowning due to traumatic injuries.

The 119-page report went on to detail the presumed events of April 27-28, which are as telling as they are grisly. The panel believes *Aegean* had been motoring under autopilot for several hours when it struck the island at about 1:36 a.m. The SPOT device onboard had been steadily transmitting the boat's position, and pinged once more two minutes after the boat hit the rocks. Then at 1:43 — three minutes before it was set to ping again — the device was manually activated to send a 911 message by someone aboard. At 1:44 and 1:45 a.m., two voicemails were left on Mavromatis' wife's phone. Sadly, none of these messages were retrieved until 9 a.m.

Flotsam at the site, a large debris field nearby, the recovery of the bodies and the eventual discovery of underwater wreckage — includ-

continued on outside column of next sightings page

shopping

and current speed/direction, and 69 planning charts with the most commonly sailed transoceanic routes. Perfect for anyone planning a world cruise.

- *World Voyage Planner*, Jimmy Cornell, \$44.95 — Also new by Cornell is this companion for his 'bible', *World Cruising Routes*. Available at Amazon Marketplace, or from www.cornellsailing.com.

- *Outfitting the Offshore Cruising Sailboat*, Peter I. Berman, \$19.95 — This book will walk you through getting an



The big kiss off — The Baja Ha-Ha's annual 'From Here to Eternity' Kissing Contest left us wondering if any of the contestants have actually seen the iconic film. Eh, who cares? It's still a blast to watch and participate in!



Divers Russell Moore and Ed Harris discovered the remains of 'Aegean' at the crash site in May.

RUSSELL MOORE

— cont'd

affordable used boat ready for a cruising adventure. Get it for your buddy with big dreams.

- *Cost Control While You Cruise DVD*, Lin & Larry Pardey, \$19.95 — Part Four of the Pardeys' Offshore Sailing DVD series will help you figure out how much it will cost you to cruise and how to cut costs. Perfect for every Pardey fan.

- *The Boat Galley Cookbook*, Carolyn Shearlock & Jan Irons, \$36 — This is one continued in middle column of next sightings page

aegean — cont'd

ing the boat's engine — at the island leave no doubt that *Aegean* ran into North Coronado Island. Though the panel determined that an inadequate lookout was the primary cause of the accident, during their investigation they discovered additional safety issues that could be addressed to prevent future accidents:

1. Always maintain a lookout, with a watch of at least two people, using audible waypoint and radar alarms.
2. Racers need to be made aware of the light obscuration zones in the Coronado Islands.
3. Each watch must understand the operation of the boat's navigation systems.

continued on outside column of next sightings page



PHOTOS LATITUDE / ANDY

SIGHTINGS

aegean — cont'd

4. The use of autopilots while motoring should be reviewed by race organizers.

5. To improve communication, racers should monitor VHF 16 and race organizers should provide a 24-hour emergency contact.

6. US Sailing should create a guide to emergency signaling devices.

7. US Sailing should create a crisis management template for race organizers.

The last item on the list would undoubtedly be appreciated by race officials as most smaller races are run by volunteers who rarely have the time and/or knowledge to significantly update race rules. Serious accidents happen so rarely — no matter what the mainstream media want you to believe — that inexperienced race officers might easily get flustered during an emergency. Having a guide or checklist to

continued on outside column of next sightings page

shopping

book we can heartily endorse because we own it. It's crammed full of tips for cooking aboard — such as the fine art of Thermos cooking — and 800 recipes that don't require *crème fraîche* or truffle shavings. Recommended for any galley wench.

If you're looking for a good salty read, check out these options:

- *Tightwads on the Loose: A Seven-Year Pacific Odyssey*, Wendy Hinman, \$14.95 — As a frequent *Changes in Latitudes* contributor, Hinman detailed her and her husband's cruise on their Wylie 31 *Verella*. A must-read for any would-be cruisers, especially those of the feminine variety.



PHOTOS COURTESY RICE FAMILY

— cont'd

• *Child of the Sea*, Doina Cornell, \$19.95 — The Cornell family has been busy this year. This is the memoir of Jimmy & Gwenda Cornell's daughter as she grew up cruising the world. Great for kids and parents alike.

• *Race France to France, Leave Antarctica to Starboard*, Rich Wilson, \$15 — The exciting story of the second American to ever finish the Vendée Globe Race (2008-09). Pick this up to find out what it's really like for the 14 racers remaining (out of 20) in the current edition of this solo, nonstop around-the-world race.

continued in middle column of next sightings page



'Argonaut' has a steel hull and deck, and an aluminum house. Rice's family wonder if she may still be afloat in Indonesia.



aegean — cont'd

follow when things are getting crazy would help ensure nothing gets missed.

As they have been since April, our thoughts are with the families and friends of those killed in these terrible accidents. Hopefully we can all learn something that will make us safer on the water, not the least of which is to always maintain a proper lookout.

— ladonna

the strange disappearance of argonaut

On August 10, John Rice's family received the life-changing news that Rice, a 60-year-old Australian who had lived for many years in Long Beach, had been reported dead while sailing in the Flores Sea in Indonesia. His French Canadian crewmember, Guillaume Gosselin, reported to officials in Kupang that 14 days earlier, he and Rice had been off Pamana Island in rough conditions when the 59-ft steel-hulled *Argonaut* began filling with water through the head portlight.

He said that Rice refused to abandon ship but Gosselin decided to take his chances in the water.

According to his official story, Gosselin watched *Argonaut* slip beneath the water. The only things that floated to the surface, Gosselin said, were the outboard fuel tank, an oar, a lifejacket and John Rice himself. He says he swam over to Rice, who was unresponsive, and

checked his pulse. Finding no pulse, Gosselin tied the floating outboard tank to Rice and began swimming for a nearby buddy boat. According to Gosselin, the mile-distant Nordhavn 46 *Kanaloa*, owned by multi-circumnavigators Heidi and Wolfgang Hass, didn't see him so he paddled toward the nearby island, also about a mile or so away. Apparently he didn't make it to the island, as he says he was in the water for two days before a fishing boat rescued him and took him to 350-mile-distant Kupang, a trip that took 12 days.

John Rice's daughter, Chelsea Rice-Morris is confused by this account of her father's death. "The story doesn't make any sense," she told us. "My father was a marine engineer and he built *Argonaut* to be unsinkable. It was one of the best-built vessels many had ever seen and had the best equipment, so it seems impossible that the boat sank in just a couple of short hours."

According to Rice-Morris, *Argonaut* had been sailing in company with *Kanaloa* since departing Darwin, Australia, on July 14. Rice had spent 18 years perfecting the steel sloop into a stout world cruiser. A very experienced seaman, he was no stranger to rough weather, which Rice-Morris says didn't faze *Argonaut* in the least. On July 25, the two boats were just a few miles apart near the small island of Pamana in the Flores Sea. In a letter provided by Rice-Morris, Heidi Hass informed the Indonesian investigators that she and Rice were in contact at least twice a day on the VHF. She says her last contact with him was around 2 p.m. "The seas were a bit choppy, with three to four feet and white caps," she wrote. "For *Argonaut* and *Kanaloa*, these were just 'lake-like conditions'. No swell or any danger."

Hass went on to say, "Neither of us even considered that the *Argonaut* could sink, definitely not what I heard Guillaume said happened, which is almost impossible. I am not an expert, but no amount of water could have come through the toilet window on the starboard

continued on outside column of next sightings page



Wolfgang and Heidi Hass (left) had been buddyboating with John Rice for months before he disappeared.

argonaut — cont'd

side to sink the *Argonaut*.”

What further frustrates Rice's family and friends is that, according to Rice-Morris, the Indonesian government searched the wrong area for debris and have yet to question the Hasses about that day. “I really want to know what happened during those 14 days because, as far as we know, the investigators haven't even questioned the crew of the fishing boat. We've been going in circles with them,” she said. “It's been nothing but heartbreak and confusion.”

Rice-Morris holds out little hope that her father is still alive, but she says what she really wants is to get the full story of what happened that day. She doesn't know if that day will ever come, but she hopes that cruisers will keep an eye out for any boat resembling *Argonaut*. If you suspect you've seen her since July 25 — or have any pertinent information in the case — get in touch with the family through a website they've set up: argonautissing.com.

— *ladonna*

boeing 777 rescues sailboat

Okay, so the headline might be a bit fantastic but the story is very real. On October 3, Australian Glenn Ey, 44, set off singlehanded from Pittwater, just north of Sydney, on a cruise of the eastern coast of Oz aboard his Cavalier 36 *Streaker*. All was well — “It was beautiful, really,” Ey said of the weather — until a southeasterly gale blew up toward the end of his second week. Not wanting to get caught inshore during a gale, Ey heaved to and set *Streaker* on an offshore course. Mid-day on October 14, Ey said “a huge wave came along, picked me up and just rolled me over.” He recalled sitting on his settee one moment, smashing into the overhead the next, and then landing on the table. “It all happens very quickly and it's most unpleasant.”

With the companionway door torn off in the rollover, water flooded into the boat. “Everything was just floating around and I was up to my

knees in water,” Ey said. “I put my head up and the mast was down. It was in three pieces.” That's enough to tempt even the saltiest sailor to set off his EPIRB, but Ey spent the next 36 hours cleaning up the mess and bailing out the boat. He initially tried to bring the largest piece of the mast aboard to set up a jury rig but the conditions were so severe he was concerned it might hole the boat. In the end, he jettisoned the whole lot. “Your first priority is survival,” he told an interviewer who asked why he didn't immediately set off his beacon. “If your boat is holed, you're going down and an EPIRB won't save you then.”

Believing he was about 100 miles offshore, Ey spent the next day or so trying to make his way to Sydney — under power when conditions had calmed and under a jury rig he set up with his spinnaker pole. Then he ran out of fuel and realized that a strong current had pulled him farther out to sea than he'd originally presumed. At 8:15 a.m. on October 16, Ey set off his EPIRB.

The Australian Maritime Safety Authority (AMSA) requested two commercial flights to divert and search in the vicinity of the signal about 270 miles off Sydney. Ey had not registered his EPIRB so they had no information other than the location. An Air Canada Boeing 777 was first on the scene and it wasn't long before sharp eyes on-

continued on outside column of next sightings page



AMSA

An airliner first spotted the dismantled 'Streaker' drifting in the Tasman Sea.

shopping

• *Hostage: A Year at Gunpoint with Somali Pirates*, Paul & Rachel Chandler, \$15.95 — Start reading this harrowing account of a kidnapping that caught the world's attention and you won't be able to put it down. Not for the faint of heart or those with an irrational fear of piracy.

• *Maiden Voyage*, Lois Joy Hofmann, \$29.95 — A beautiful coffee table book featuring photos and stories of Lois &

Happy
Holidays

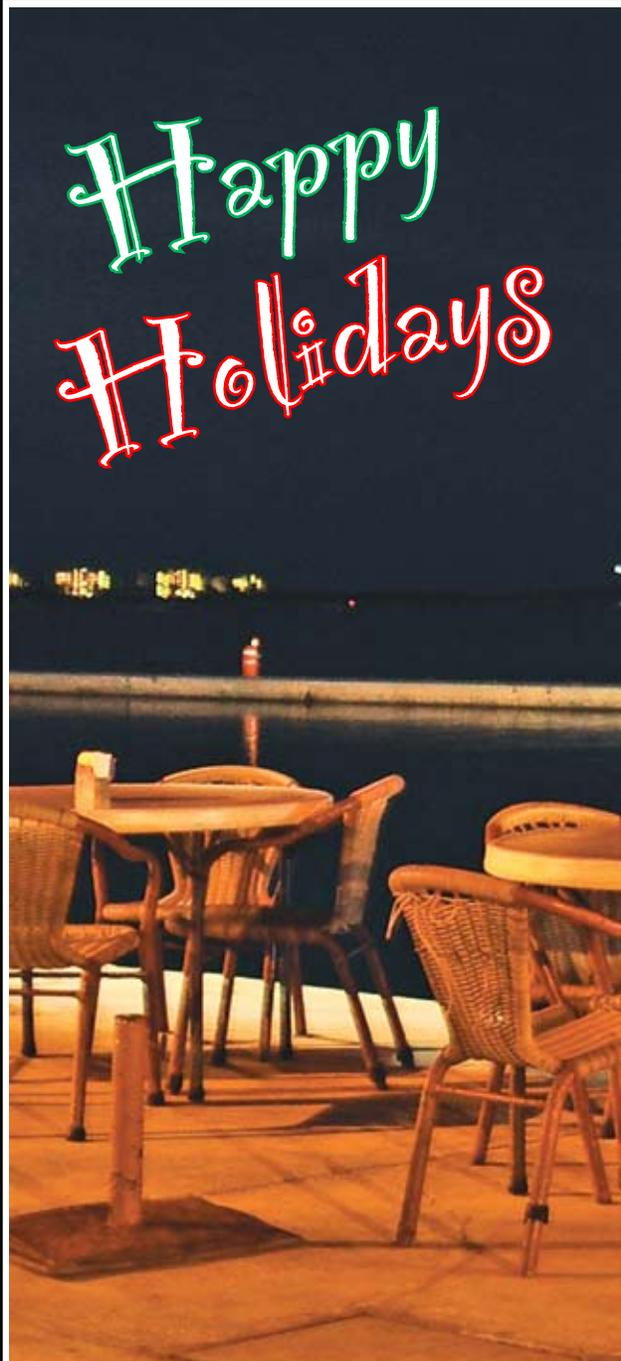

— cont'd

Günter Hofmann's eight-year circumnavigation aboard their 43-ft Catana *Pacific Bliss*. A great gift for those who enjoy pretty things.

We hope this helps ease your holiday shopping angst *and* gives you a good excuse to explore the many other newly released sailing books available. And don't forget to circle the ones you want and leave this article out where your loved one can't miss it. Happy holidays!

rescue — cont'd

board spotted the stricken *Streaker*. A later Air New Zealand flight confirmed the sighting, and a merchant vessel diverted to the boat's location to stand by while awaiting the New South Wales water police for rescue.

Ey was not injured during his ordeal and, unfortunately, *Streaker* is still adrift in the Tasman Sea. He says he doesn't plan to go to sea again anytime soon — "I'd be quite happy to sit under a tree for a while," he said — but when he does, manufacturer GME will give him a properly registered GPS-enabled EPIRB for the trip. If you haven't registered your EPIRB, there's no time like the present!

— *ladonna*

from the crew at
Latitude 38



TOM BROWN / EAGLE

BAJA HA-HA XIX RECAP —

More than six months before the start of the Baja Ha-Ha XIX cruising rally, organizers chose 'Don't Stop Believin' as its theme, rationalizing that this hopeful directive — which was borrowed from the title of a sappy early-'80s rock anthem — symbolized the unflag-

the rally.

Halfway through the annual Cabo beach party (November 9), a full day after the bulk of the fleet had arrived, rally organizers were considering alerting search and rescue resources because Pomeroy — who'd been singlehanded nonstop for a week since leaving Turtle Bay with a defunct engine — had not been heard from for more than 24 hours. At that very moment, though, Dawn Hilliard of the vintage San Juan Islands-based schooner *Destiny* rushed past on her way to greet an approaching dinghy and shouted: "He's here! Rich made it."

By that point, some concerned fleet members had learned the backstory to Pomeroy's Ha-Ha campaign, which made singlehanded for 400 miles with little sleep seem like a cinch: A massive stroke three years ago left his right side paralyzed and robbed him of the ability to speak. But

after endless hours of therapy the former construction boss achieved a remarkable comeback during the past year, regaining not only his motor functions, but also his ability to converse normally. So for Pomeroy, just sailing across the starting line of Baja Ha-Ha XIX was a colossal accomplishment.

Although the impediments other entrants faced along their paths to the cruising life may seem trivial by comparison to Pomeroy's, many are notable nonetheless. For example, the Hilliards of *Destiny* recently completed an exhaustive, three-year refit of their 1934 classic — which once belonged to eccentric aviator Howard Hughes. Others had similar stories: "The *Emerald Lady* was almost derelict when we bought her two years ago," explained John and Kelly Wanamaker of Seattle. "Today she is a fully bluewater-capable boat looking for many years of new adventures." According to Darrell Powell-Ford of Alameda, "We've completely gutted and restored *Rubber Duckies* ourselves." She's a 1974 Coronado 45 that was easy to recognize out on the ocean by the four cartoon

duckies emblazoned on her hull.

Rob and Nancy Novak of Sausalito came close to missing the rally entirely, but not because their lovely Oyster 485 *Shindig* needed a refit. While laying over at the Morro Bay YC guest dock during their trip south, they were side-tied to a large motoryacht that burst into flames in the middle of the night. Awakened by screaming, Rob and Nancy shoved off quickly enough to avoid disaster, but as Rob recalls, "Three minutes later we would have been totally engulfed in flames!" Two-time Ha-Ha vet Judy Stouffer of the Alameda-based Catalina 42 *Milagro* wasn't so lucky. During the trip down the coast to San Diego, she was thrown across the boat and fractured a vertebra in her back. But she

Gentle zephyrs of sea breeze began to whisper in from offshore.

insisted that her husband Michael carry on without her. (She hopes to join him eventually in La Paz.)

As in previous rallies, this year's fleet was composed of all sorts of sailboats — as well as three powerboats — that ranged from bargain-priced fixer-uppers to top-notch, all-ocean cruisers such as the spectacular Swan 77 *Cygnus Montanus II*, whose mast was twice the height of some boats she glided past. But as every new cruiser quickly learns, any decent boat will take you to the same beautiful anchorages.

It was also typical that the backgrounds of fleet members were as diverse as the boats they sailed on: firefighters, teachers, aerospace engineers, ski instructors, heavy equipment operators, physicians — even a brewmaster. But as always, not long into the trip the experience of cruising under sail together would prove to be a great societal leveler, fueling the natural camaraderie that results from a shared adventure.

As regular readers know, the first official event of the Ha-Ha is the Pre-Halloween Costume Kick-Off Party, co-hosted by West Marine at their superstore complex near Shelter Island (Sunday, October 28). In addition to the predictable assortment of swashbuckling pirates and saucy wenches, there



With West Marine managers doing their amusing piratical schtick, costumed contestants strutted their stuff at the Kickoff Party.

ging determination of many entrants to keep stoking the flames of their cruising dreams and ultimately make it to the Ha-Ha starting line, October 29, despite whatever obstacles they had to overcome to get there.

Little did the Rally Committee know during the planning stages of this 750-mile San Diego-to-Cabo San Lucas cruise just how severe some of those obstacles might be. By the end of the event, Rich Pomeroy of the Astoria, Oregon-based Polaris 43 *Flying Carpet* emerged as the obvious poster boy for the 'Don't Stop Believin' theme due to his struggles both before and during

"Hurry up and snap the darn photo. This sucker's heavy!" Phil of 'Silhouette' (might have) said. Warmer water seemed to aid in the hunt.



ALL PHOTOS LATITUDE / ANDY EXCEPT AS NOTED

SILHOUETTE

TRUE BELIEVERS



were mutants, goblins, killer bees, human jellyfish, Polynesian princesses, Vikings, and even a cadre of Knights of the Round Table, presided over by the fleet's elder statesman, 84-year-old Howard Shaw (AKA King Arthur), skipper of the Oregon-based Hunter 54 *Camelot*, and his queen, Donna, who is 79 years young. The fleet's youngest sailor, by the way, was 17-month-old Nathan Bereson of the Seattle-based Young Sun 43 *Second Sun*. He came dressed as. . . a baby in diapers.

West Marine managers Galen Piltz and Ron Maggi — both decked out as buccaneers — emceed the annual costume contest and kept the crowd amused with silly piratical antics and admittedly bad pirate jokes. Many event sponsors were on hand to exhibit their wares. Ernesto the taco man and his crew tirelessly cranked out three types of tacos for hours. And, due to the abnormally hot weather, the Ha-Ha bartenders had to call for an additional "emergency keg."

Naturally, there's always a high level of anxiety among first-time cruisers, but conditions this year couldn't have been much more benign: The forecast from event sponsor Commanders' Weather was for several days of light winds and relatively flat seas, with clear, sunny

Killer bees, wenches, Vikings. . . The quality of costumes this year was excellent, and many masqueraders played their roles to the max.

days and a full moon rising just after sundown on the first night out.

On their way out of San Diego Harbor Monday morning, the fleet formed a loose procession as it passed well-wishers ashore and a boatload of print, radio and TV reporters. Also aboard the V.I.P. vessel *Dolphin* were U.S. and Mexican dignitaries, one of whom fired the official America's Cup shotgun to salute the departing parade.

A short time later, the Rally Committee surveyed the seas outside the harbor from the event's mothership, the 63-ft cat *Profligate*, and concluded that there wasn't enough breeze to sail in. So they reluctantly announced a "rolling start," whereby all boats could motorsail down the rhumbline at no more than six

knots until the breeze filled in.

But no sooner had crews adjusted their RPMs and resigned themselves to motoring than gentle zephyrs of sea breeze began to whisper in from offshore. At 11:30 the official (sailing) start was declared, as the wisps of wind had built to a steady five knots — still not much pressure, but enough to fly light-air chutes and creep south across the border toward the Coronado Islands. As if commissioned by the Mexican Tourist Board, several pods of playful dolphins appeared soon after the start to usher the fleet south.

The weird thing that day was not the light wind, but the eventual presence of dense sea-level fog that hung in clumps

for several miles offshore. At one point, it was so thick that some boats reported being able to see only a couple of boat lengths in front of their bows — a disconcerting experience when you're flying a broad-shouldered symmetrical spinnaker. One com-



Although there was barely any breeze for the 11 a.m. start, within a half hour it filled in nicely, allowing chutes to be flown with ease.



BAJA HA-HA XIX RECAP —

fort was that for the first time ever the Rally Committee had required all boats to have either AIS or radar.

Fortunately, just south of the Coronados the fog dissipated and the fleet plied southward under clear, sunny skies. Just as air temperatures were warmer than in previous years, the sea temp was higher too — about 62° just south of San Diego. And as several Mexican friends had predicted, the warmer-than-usual water meant that game fish were boated farther north than usual. In fact, less than an hour after the start the excited voice of Jerome Phillips was heard on the VHF exclaiming in his unmistakable English accent that the first catch in the fleet had been brought aboard his Oregon-based Hershine 41 trawler *Kinda Blue*.

As spotty cloud cover moved in late that first night, the fleet found an increase in wind beneath it — up to about 10 knots — giving watch-standers blissful, light-air sailing, while their off-watch mates slept soundly without the

annoying drone of diesel engines.

The first of many sensational sunrises greeted the fleet on day two. Compared to previous years there was little drama to report during the mandatory 7:30 a.m. radio check-in, although aboard *Sisu*, Christopher and Barbara Warnock's San Francisco-based Hans Christian 43, the pricey, brand-new, carbon-fiber spinnaker pole somehow broke into two splintered halves "with a horrible crunching sound" in a mere three knots of breeze. Go figure.

By late afternoon that day some boats were reporting 12 to 15 knots of breeze, and most had at least 10, allowing even the most heavily laden cruisers to move nicely down the rhumbline of this 360-mile leg. Before the slightly waning full moon flooded the sky with

light that evening, helmsmen could line up their forestays with Orion's belt to guide them south. After all the pre-start angst, this idyllic, low-stress sailing was the perfect recipe for rejuvenation and confidence-building.

Day three (Wednesday) was another splendid day of easy sailing with steady breeze in the 10-15-knot range and mostly clear skies overhead.

On the approach to Turtle Bay (Bahia Tortugas) the water temperature had risen to 74° and the game fish were active. Among the most impressive conquests: Crew aboard Marian Croyle and Neil Calvert's Alameda-based *Hylas 44 La Boheme* bagged a 55-inch wahoo, and aboard the Texas-based *Beneteau 423 Silhouette* Phil Donato brought in a 47-inch mahi. But the crew of *Heavy*

Clockwise, from upper left: Nearly everybody took a swing or two; lady sailors muscled the tug-of-war hawser; plenty of fish to share; barefoot V-ball is always a hit; pinata pugilism; taking on fuel from a mobile supply boat; feasting at the potluck; beach party in progress; dancin' to the rock 'n' roll and salsa 'til the sun went down.



FINN BEVIN

ALL PHOTOS LATITUDE / ANDY EXCEPT AS NOTED

TRUE BELIEVERS

Metal, Rigo and Deborah Fuzetto's San Francisco-based custom 60-footer, undoubtedly bagged the most: 48 fish of various types, which left everyone wondering, "Just how big is their fridge, anyway?" Some catches were a bit too big: The *Kinda Blue* crew snagged an 8-foot shark, estimated to weigh about 300 lbs. Somehow they wrestled him aboard long enough to retrieve their \$50 lure, then set him free without losing any fingers or toes.

That evening, as more than a dozen of the lead boats converged several miles outside the broad Turtle Bay entrance, a brilliant moon rose over the Baja Peninsula as if specially ordered so the fleet could enter and anchor with ease.

Due to the relatively mild conditions, there was little drama and destruction to report on the morning net, at least in comparison to some previous years. The number of blown-out sails was

comparatively low, although there were a few mishaps. Aboard Tom Van Dyke's San Francisco-based Searunner 31 tri *En Pointe*, the crew was in the process of landing yet another fish when their spinnaker block shackle gave way and launched the chute into the sea. "Who knew you needed a swivel block for the spinnaker?" Tom quipped later. Capt. Phil of *Silhouette* admitted he had been so transfixed by the thrill of blasting along at 8.5 knots in 20 knots of wind that he temporarily lost his better judgment. "I knew I should have taken it down, but we were just having so much fun!" Yeah, they blew it up. Aboard the San Diego-based Catalina 30 *She Said Ok* Jeff Kiddy and Mike Kouris were also pushing the limits of their kite — and having big fun — when they were suddenly knocked down, which put the chute in shrimping mode. Fortunately, they recovered without trashing the sail or expending too much adrenaline.

But Michael Bowe of *Patanjali* told the scariest tale: During his approach to the bay his engine conked out and the Marina del Rey-based Catalina 42 was being washed toward the cliffs when some good-natured *panga* fishermen came along and towed her in. Speaking of escorts, many boats reported being ushered into the bay by playful pods of dolphins who seemed thrilled to have so many new visitors.

A tally after roll call revealed that eight boats had sailed the whole way, and several others motored only a very short distance.

The fleet received its usual warm welcome from the people of Turtle Bay. And no wonder. The arrival of the Ha-Ha armada each fall is by far the biggest event of the year here. Ashore, fleet members fanned out, exploring the dusty, unpaved streets of the town; practicing their Spanish with the local fisherfolk and shopkeepers; perusing



BAJA HA-HA XIX RECAP —



CYGNUS MONTANUS III

The gregarious Danes on 'Cygnus Montanus II' provided this evidence that their marlin-catching saga was real.

the spartan shelves of the town's modest *tiendas*; reconnecting with reality at the Internet cafe; hiking the nearby hills; and chilling out at several beach-front watering holes.

Although community life here revolves almost entirely around fishing, the townspeople do have another passion: baseball. Believe it or not there are three traveling teams based here, with players age six to adult. Ever since they built a ballpark several years ago, it's been a tradition to play an 'exhibition game' there where all Ha-Ha'ers and local kids have a chance to bat. As always, the rally's Grand Poobah (*Latitude's* Richard Spindler) presided over the mound, lobbing lazy pitches for hours and giving up roughly 2,000 hits, without a single strikeout. To say the efforts of the Ha-Ha fielders lacked pol-

One of the unanticipated thrills of standing watch at odd hours is occasionally witnessing spectacular sunrises like this one.



LATITUDE / ANDY

ish would be a gross understatement. There were usually at least three errors per hit, but in their defense, only a few had brought gloves. Needless to say, everybody went away smiling.

That night many fleet members converged on the town's largest restaurant, the Vera Cruz, where sailing and fishing tales were recounted, dancers practiced their moves in the on-site disco, and apparently many elbows were bent — for the first time ever they ran out of tequila!

Weather was splendid the next day for the annual Turtle Bay beach party. In addition to a massive potluck, many fishermen brought in fresh-caught mahi, tuna and wahoo to grill on the communal 'cue, and share with whoever wanted a taste. While some sailors were happy just to kick back on the sand and catch up with friends, many played soccer, volleyball and other beach games on the flat pan left by the receding tide.

Leg Two takes the fleet south to remote Bahia Santa Maria, a rhumbline distance of 240 miles. It was slated to start at 8 a.m., although many stragglers hadn't even gotten their hooks up by that hour. Again, wind was almost nonexistent at the appointed hour, so again the Grand Poobah declared a rolling start. It was a little spooky, though, that almost immediately a gentle offshore breeze began to build. At 8:05 the rolling start was called off and spinnakers began popping open left, right and center.

During the morning hours most crews settled into a lazy routine, playing the light wind as they slowly glided south. But aboard the big Swan *Cygnus Montanus* there was all sorts of excitement. Twelve miles south of the starting line her crew fought an hour-and-a-half-long Hemingway-esque battle with a 9-foot marlin before finally bringing the monster aboard for measurement (via a halyard), then setting it free.

The breeze held in the 8- to 10-knot range through the morning, then

built into the high teens by late afternoon, yielding spectacular sailing conditions under mostly clear skies. Commanders' Weather reported an odd situation with a weak high to the north of us and a weak low to the south, with messy, hard-to-predict pressure in between — their computer models didn't know what to make of it. At the time it was blowing 30 knots in Cabo as a

"With the moon out and the Milky Way twinkling, last night was magic."

result of a "circulation" farther south. But all that was expected to be a faded memory by the time the fleet arrived five days later.

The breeze got very light during the wee hours, but by the time of the morning net, it had piped up to the low teens again, putting smiles on the faces of fleet members as they hoisted their spinnakers yet again.

During the morning roll call we learned that several boats were having mechanical problems. The *Rubber Duckies* crew earned good Samaritan points for delaying their start from Turtle Bay to recharge batteries and upgrade wiring on Frank Murphy's San Diego-based Cabo Rico 38 *Truant*. Ethan Johnson's Seattle-based Catalina 30 *Golden Eagle* had been delayed in San Diego, but finally caught the fleet in Turtle Bay only to experience engine problems there that would force her to sail the rest of the way to Cabo. But she wasn't alone in that predicament. Paul and Celeste Carpenter's West Coast-based Valiant 40 *The Beguine* lost the use of her tranny and, as explained earlier, the engine on Rich Pomeroy's *Flying Carpet* was kaput also. What amplified the challenges he faced, however, was that one of his two crewmen had volunteered to help out the Portland-based Hans Christian 38 *Tillie* when one of her crew had to depart suddenly at Turtle Bay due to a family emergency. And Pomeroy's remaining crewman found another ride when he realized that *Flying Carpet* might get hung up in Turtle Bay awaiting engine repairs.

Luckily, though, there was plenty of wind on most of the course for even the engine- and trannyless boats to keep moving. As the water temperature con-



TRUE BELIEVERS

tinued to rise to over 75°, fishermen — even those who relied on dumb luck rather than expertise — had continued success. Rich and Lynn Lewis of the Delaware-based Valiant 42 *Fellowship* reported boating a 57-inch wahoo. Not bad considering it was the first saltwater fish they'd ever caught. Moments after a nice big fish was brought aboard the Seattle-based CT49 *Scintilla*, her crew learned a valuable lesson about the law of the jungle: Before they had a chance to clean their catch, a mischievous seal leaped up onto the transom and grabbed an unearned lunch. As if that weren't weird enough, they also found a live bat stowed away in their spinnaker that night. It dropped to the deck during the dousing, passing inches from co-owner Christine Barnes' face. According to her boatmates, that caused her to scream with fright and "do the bat jig." Because stowaways are not allowed on *Scintilla* — and bats are creepy — it was unceremoniously sacrificed to the deep.

Meanwhile, Chris Johnson of the Nevada-based Hylas 445 *Aurora* had the unfortunate experience of snagging a sea turtle, but was able to free it quickly. Even more troubling was Eric Sellix' report of a near-miss while sailing through the night on his Oregon-based

colliding with him.

Seawind 1160 *Pied-a-Mer III*: "I heard a big splash right beside me and smelled whale breath." Yuk! Luckily, the 38-ft cat slipped past the snoozing cetacean rather than colliding with him. With most of the fleet safely anchored in the vast, well-protected Bahia Santa Maria by the time of the third morning's net, the simple bliss of peaceful offshore sailing in near-tropical temperatures came through loud and clear: "This was the first time we'd ever sailed barefoot," said Michael Boone of the Oregon-based Hunter 44 *Desert Vision*. "It's been a long time since we could lie out on the tramps and gaze up at the stars," added Peter Brown of the Port Townsend, WA-based Grainger 48 *Taj*. "With the moon out and the Milky Way twinkling, last night was magic," said Dawn of *Destiny*. "This has been the best sailing we've ever done in our lives."

The vast oblong bay of Santa Maria is typically the favorite stop on the Ha-Ha itinerary. Steep, craggy ridgelines abut its western shore, and a lush, maze-like estuary skirts its north end, beyond which lies a primeval carpet of sand dunes — untouched by the influences of man — that stretches as far as the eye can see. Thanks to the recent passing of Hurricane Paul, the normally scrubby hillsides were greener this year than we'd ever seen before.

With the water temperature at least 75° and the sun baking down from a brilliant blue sky, the first lay day here was dedicated to swimming, kayaking, paddleboarding, hiking and beachcombing — oh, and catching up on lost sleep, of course.

The only inhabitants here are itinerant fishermen who live in ramshackle huts for stints of several months at a time while working for the local fish cooperative. Over the years these rugged *hombres* have become great friends of the Ha-Ha. Like a magician, their de facto leader, Victor Felix, somehow organizes a party for the whole fleet on the bluff above the estuary mouth, complete with a fish and shrimp dinner, ice-cold beers brought in from many miles away, and a four-piece rock 'n' roll cover band complete with drums, keyboard, electric guitars and a PA system. Each year they travel 120 miles up the highway from La Paz, then transfer to a flatbed truck for a 40-mile ride across the desert, before forging a river on a rickety ferry, then driving another 20 miles down the beach at low tide. And after all that they play only for tips! Not only are these guys dedicated, but their talent is awesome. The lead guitar player, for example, can cover Carlos Santana and Eric Clapton solos note-for-note. Needless to say, the Rally Committee always makes sure they are handsomely



LATTITUDE / ANDY

When the wind is relatively light, some sailors get creative. Flying double headsails kicked this heavy cruiser into overdrive.

Below: Light breeze, flat seas and sunny skies made for low-stress sailing. Left: Megan takes a refreshing dip off 'Truant's bow.



TRUANT



LATTITUDE / ANDY

BAJA HA-HA XIX RECAP —



ALL PHOTOS LATITUDE / ANDY EXCEPT AS NOTED

rewarded.

By this point in the rally the shared experience of traveling offshore along the same route had accelerated newly formed friendships, so that folks who met only 10 days earlier now swapped tales and shared personal insights as though they were old friends. The 'kid boat' people had all met each other, and some were already planning to buddy-boat beyond Cabo.

By this point also, many first-time voyagers had realized that downwind, near-shore sailing isn't so tough after all. And many undoubtedly wished they'd quit procrastinating and headed south years earlier.

The start of 180-mile Leg Three is always slated for the rudely early hour of 7 a.m., with the goal that the smaller and slower boats will have to spend only one night at sea. But there isn't always much breeze at that hour, and this year the wind gods were definitely taking the day off. In fact, most boats never saw

Clockwise, from upper left: Conga lining at BSM; Viking attack; dolphins often came out to play; Cabo's 85° water was inviting for all ages; the famous Cabo arch; (inset) the king and queen of Camelot; the 'Moontide' crew practices synchronized swimming at the Tropic of Taurus; the inviting BSM estuary; spinnaker parade on the track to Cabo.

the breeze pipe up above 8 knots the whole way to the finish off Cabo Falso, five miles from the harbor.

Again, several boats delayed their start to help others. Notably, the Australia-based Beneteau 393 *Calypseaux VII* towed (trannyless) *The Beguine* down the course — but only until they hooked a dorado and said, "Sorry, gotta go!"

Later that day Rich Reiner of the San Francisco-based Oceanic 45 *Mandolina* announced that he'd picked up a kayak 22 miles outside the anchorage. Turned out it belonged to the Richmond-based Hunter 36 *Grey Goose*, and had disappeared from a boat party the night before — apparently due to a 'WTF knot'.

Roughly a half-dozen kid boats decided to delay their departure so they could have another glorious beach and surf day with their kids while waiting for the wind to improve. (As always, variations from the basic schedule were

never a problem, as long as the Committee was informed.)

Although Leg Three was a bit of a yawner in terms of fun under sail, air temperatures in those latitudes were hot, hot, hot — while much of the West Coast from California to B.C. was bundled up in rain gear — and the fish were still biting.

Because most boats were motorsailing south at roughly the same speed during that warm, starry night, the fleet was more concentrated than ever. In fact, the number of 'targets' visible on radar and AIS screens looked as though the Allied Fleet were about to invade Normandy. Luckily, visibility was crystal clear and no one fell asleep with their autopilot on.

Meanwhile, somewhere at the back of the pack, Rich Pomeroy's personal ordeal was playing out on its own tortured timetable. Winds had increased

TRUE BELIEVERS

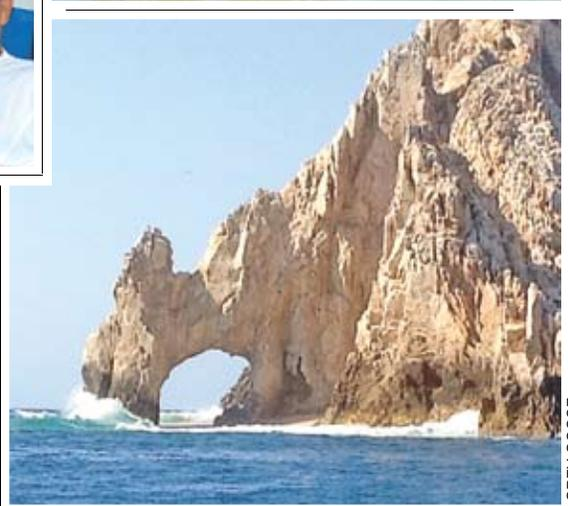

sharply during the two days when the fleet was snugly anchored at Bahía Santa María, but Rich was still out in it, sailing solo and taking a beating. Having never come into BSM before — and perhaps being less than clear-headed due to sleep deprivation — he elected *not* to brave the entrance and pull in to get some sleep. As he learned later, of course, few places along the West Coast have a more forgiving entrance (unobstructed and seven miles wide), and a more wide-open anchorage (four miles across and relatively shallow) where he could easily have sailed both on and off the hook.

In any case, by the time the fleet was nearing Cabo on the second morning of Leg Three, Rich sounded thoroughly exhausted and dispirited. Nevertheless, his solar panels were still providing him battery power, and the wind was no longer threatening, but instead maddening light. Rich's friends in the fleet, as well as Rally Committee members, were concerned, but he was in no immediate danger.

It would be hard to exaggerate the contrast between the unspoiled beaches of Bahía Santa María and the raucous streets of Cabo San Lucas. A long-time mecca for party-hearty tourists and serious fishermen, the frenetic, high-energy vibe of its countless bars, restaurants and nightclubs is the polar opposite of Santa María's natural serenity. But when you've been out at sea for the better part of 10 days, that first long marina shower and well-blended margarita are welcomed manifestations of civilization. And after being cramped up in the confinement of a sailboat interior, it's downright therapeutic to cut loose on the dance floor of the notorious Squid Roe bar with a couple hundred of your closest Ha-Ha fleet mates. As rally veterans know, this is an unofficial yet well-established Ha-Ha tradition.

Although for decades Marina Cabo San Lucas has catered primarily to sportfishing boats, its current director, Darren Carey, is determined to make

his facility equally welcoming to sailors. To that end, rates were lowered dramatically this year and, as always, his staff worked closely with the Rally Committee to shoehorn in as many Ha-Ha boats as possible. By Friday morning, they'd found room for over 60 of them.

That afternoon several hundred fleet members gathered under a cluster of sun umbrellas at the waterside Baja Cantina Beach Restaurant for the annual Ha-Ha beach party. With many sailors basking in the glow of personal satisfaction after successfully completing the trip — or was it the glow of happiness fueled by two-for-one margaritas? — new friends made plans to meet up again in distant anchorages, or buddy-boat together to La Paz, Mazatlan or Puerto Vallarta.

The highlight, as always, was the *From Here to Eternity* kissing contest, where lovers were meant to imitate the iconic, surf-splashed embrace of Burt Lancaster and Deborah Kerr at the end of that classic black-and-white film. (See *Sightings*.) By that time Rich

BAJA HA-HA XIX RECAP



Pomeroy had come ashore with a hero's welcome from those who'd been monitoring his ordeal, and he too was able to have a few laughs at the lovers' antics.

The Awards Ceremony, generously hosted by the marina, saw the usual mix of praise and comedy, with the

It's probably safe to say no one was happier to reach Cabo than Rich Pomeroy.

Grand Poobah emceeding while wearing a black tailcoat with shorts and sandals. Every boat took home a prize, and three — Patsy Verhoeven's La Paz-based Gulfstar 50 *Talion*, George Woodley's Nevada-based Corsair 31 tri *Flying Fox*, and the Shaws' *Camelot* — were singled out for having sailed the whole way despite periods of little or no wind. In addition to gag awards for everything from "extreme snoring" to "spinaker destruction," this year's Spirit of the Ha-Ha Award went to Dr. Electron

(Alan Katz) of the Choate-40 *Wizard*, for tirelessly aiding whoever needed assistance with a wide variety of electrical malfunctions.

All in all, it was a splendid two weeks

on the water, a just reward for more than 400 sailors who refused to *stop believin'* in their cruising dreams. As they travel on, hopefully some will write in and tell us about the ongoing adventures they're having 'out there'.

— **latitude/andy**

Baja Ha-Ha XIX Division Winners

+ indicates sailed all of one leg; § indicates sailed entire course — "Soul Sailors"
(117 finishers with 426 sailors aboard. For complete results see www.baja-haha.com)

AGAVE DIVISION: **1+) *Distraction***, Olson 911, Don Lavery; **2) *Thunderbird***, Albin Stratus 36, International Rescue Group

BURRITO: **1) *Oceania***, True North 34, Derek Shaw; **2) *Mariah***, Gulf 32, Ken Painter

CEVICHE: **1) *Grey Goose***, Hunter 36, Alan & Linda Brabon; **2) *Alcyone***, Ericson 36, John & Cynthia McDaniel

DESPERADO: **1) *Rhapsody***, Herreshoff 36, Alan & Laura Dwan; **2) *Talos IV***, Pacific Seacraft 36, Paul & Janet Baker

ENCHILADA: **1++) *The Bequine***, Valiant 40, Paul & Celeste Carpenter; **2) *At Last***, Sabre 38, Delayne Brink & Vicki Brighton

FRIJOLE: **1) *Scot Free IV***, Hylas 42, John Harper & Deborah Martin del Campo;

GUACAMOLE: **1+) *Silhouette***, Beneteau 42, Phil Donatto; **2+) *Patanjali***, Catalina 42, William Walters

HUEVOS RANCHEROS: **1++) *Mondolina***, Oceanic 45, Rich Reiner; **2+) *Fluenta***, Stevens 47, Max Shaw & Elizabeth Brown-Shaw

IGUANA: **1+) *Wallflower***, Kalik 44, Deron Bardin; **2+) *Pacific Highway***, Davidson 44, Bruce & Laura Masterson

JALAPENO: **1§) *Talion***, Gulfstar 50, Patsy Verhoeven; **2+) *Distant Drum***, Ikyll 51, Harry Hazzard

KILO: **1) *Iataia***, Beneteau 45, Sara & Marcos Rodriguez; **2) *Inspirare***, Bavaria 47, Annika & Arvid Elias

LANGOSTINO: **1§) *Camelot***, Hunter 54, Howard & Donna Shaw; **2) *Cygnus Montanus II***, Swan 77, Richard Jakaus & Paul Warneke

MARGARITA: **1§) *Flying Fox***, Corsair 31, George Woodley; **2++ tie) *Pied-a-Mer III***, Seawind 1160, Eric & Pam Sellix; **2++ tie) *Moontide***, Lagoon 470, Bill Lilly & Judy Lang

NO COMPRENDE (power): **1) *Oogachaka***, Krogen 42, Ken & Patty Seby; **2) N/A**

MEXICO CRUISERS STEP ONE:

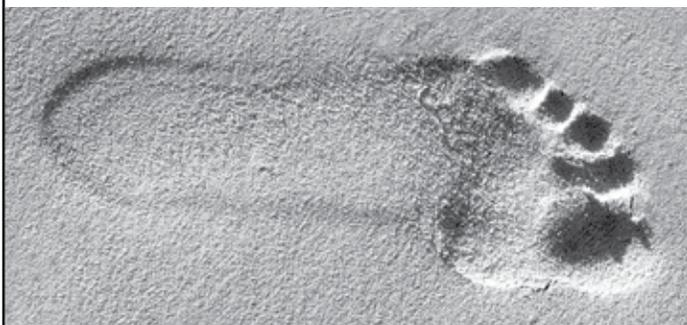

MAKE A RESERVATION AT MARINA EL CID
FIVE STARS FULL SERVICE MARINA
MAZATLAN

*You'll get such a great "impression"
from our marina services and beaches,
you may never leave!*



El Cid
RESORTS
mazatlan • cozumel • cancan

www.elcidmarinas.com

011-52 (669) 916-3468

marinaelcidmazatlan@elcid.com.mx

OPEQUIMAR

MARINE CENTER CENTRO MARINO

Our Experience Makes the Difference



High velocity pump fuel dock, 46 gals./min. • Travelift: 88 tons, 100' length, 23' beam
Dry storage for vessels up to 300' • VHF radio ch. 68 • 24-hour security • Dock rentals
Sales & rent of used & new boats • Full service boatyard • Do-it-yourselfers welcome

The Most Complete Marine Center Open 365 Days
Puerto Vallarta, Jal. Mexico / Tel: (322) 221-1800
www.opequimar.com / info@opequimar.com

BAJA HA-HA XIX



BROUGHT TO YOU
BY THESE
OFFICIAL SPONSORS

WWW.BAJA-HAHA.COM

The Rally Committee encourages you to patronize the advertisers who make this event possible – and take advantage of their Baja Ha-Ha Specials! (Turn the page for more.)

Your
Yacht Club
South of the
Border



Vallarta Yacht Club

<http://vallartayachtclub.org>
<http://banderasbayregatta.com>

Everything you need from a full service yacht club.

Home
of the
Banderas Bay
Regatta

BAJA HA-HA MELTING POT

One look at the Ha-Ha XIX entry roster at www.baja-haha.com shows you that boat types in this year's fleet were as varied as ever, and you can bet that the crews who sailed them are as colorful as in years past.

In addition to many first-timers, there were plenty of 'repeat offenders' who wanted to replay some of the fun and great sailing that they'd experienced the last time around. Some full-time Mexico cruisers even sail all the way back to San Diego each fall just to re-do the rally.

If you're new to the event, let us explain that the Ha-Ha is a 750-mile cruisers' rally from San Diego to Cabo San Lucas, with stops along the way at Turtle Bay and Bahia Santa Maria.

Baja Ha-Ha 2013: You'll find occasional updates about next year's event on 'Lectronic Latitude' at www.latitude38.com.

Summer
is safe at
Paradise



Paradise Village
BEACH RESORT & SPA

Enjoy
your stay
with us!

011-52-322-226-6728 • www.paradisevillage.com
marina@paradisevillagegroup.com

Nautical Books, Software, Charts
and more!



WAYPOINT

621 - 4th St., Oakland, CA

www.waypoints.com • (510) 769-1547

RIGGING ONLY

Standing and running rigging, lifelines, furlers, winches, headsail poles, main slider systems, windlasses, travelers, wire terminals, blocks and more...
Expert advice for selection and installation.

Since
1984

www.riggingandhardware.com
(508) 992-0434 • sail@riggingonly.com



Award-winning Marine Communications Equipment

Handhelds • Mounted VHF • SSB • AIS

Visit one of our many West Coast dealers

www.icomamerica.com/marine

SELF-STEERING AND EMERGENCY RUDDERS



SCANMAR
INTERNATIONAL

Factory
Direct

432 South 1st Street • Pt. Richmond, CA 94804
Toll Free: (888) 946-3826 • Tel: (510) 215-2010
email: scanmar@selfsteer.com • www.selfsteer.com

West Marine®

Call

1•800•BOATING
(1•800•262-8464)

for a catalog or the store nearest you.



Est. 1973

Almar Marinas

Everywhere you'd like to be
almar.com

BAJA HA-HA XIX



www.downwindmarine.com
2804 Cañon St., San Diego
(619) 224-2733 • (800) 269-0241



www.sandiegomarine.com
2636 Shelter Island Dr., San Diego
(619) 223-7159 • (800) 336-7369
Mexico 001-500-336-7369



www.sailingsupply.com
2822 Cañon Street, San Diego
(619) 225-9411 • (800) 532-3831

CHECK OUT THE RECAP

In this edition you'll find a complete overview of this year's rally (pg. 76), which will give you insights into what each leg of the trip entails, should you choose to join the event in the future. To learn more about this year's fleet members, read our three installments of fleet mini-profiles in the September-November editions of *Latitude38*. (Downloadable eBook archive at www.latitude38.com.)

Many crew found rides this year via our free online Crew List at www.latitude38.com, which is constantly updated. Check it out for post-Ha-Ha cruising positions, as well as spots on Bay Area daysails and races.

PACIFIC PUDDLE JUMP

For many cruisers, the next logical step after cruising Mexican waters for a season or more is to hang a right and head west into the Pacific.

We call that annual springtime migration the **Pacific Puddle Jump**, and we report on it heavily in the pages of *Latitude 38*. Making that 3,000-mile passage is one of the most thrilling accomplishments in the realm of sailing. Learn more about it at www.pacificpuddlejumps.com.



Sign up here.
Get QR Reader
FREE at your
App Store.

- Ultra Anchors • Ultra Swivels
- Quickline Flat Rope & Reel • Ultra Trip Hooks
- Ultra Chain Grabs, Ultra Snubbers & Ultra Bridles



www.Quickline.us
www.UltraAnchors.us
sales@Quickline.us
714-843-6964

The World's Highest Quality Marine Products



Not just a marina – a cruiser's community
Your best destination across the Sea...

www.marina-mazatlan.com

011-52 (669) 669-2936 & 2937
jaimeruiz@marinamazatlan.com



Survive Your Dream



604-925-2660

www.hydrovane.com



YACHT BROKERAGE
SALES & SERVICE

Toll Free from US/Canada

866-578-2636

Mexican Land Line

011-52-322-297-2249

Cell

011-52-1-322-182-0006

www.vallartayachts.net

INTERNATIONAL HEALTH AND EVACUATION INSURANCE



Best in cruisers medical insurance
for the Baja Ha-Ha and beyond

WWW.HEALTHISINTERNATIONAL.COM



SAFETY
TETHERS!

wichard
Legendary stainless steel forging

www.wichard-usa.com

(866) 621-1062

info@wichard-usa.com



Let Marina El Cid
Welcome You to Mexico

A Cruiser's Paradise!

www.elcid.com

marinaelcidmazatlan@elcid.com.mx
011-52 (669) 916-3468

Serving Boaters
Since 1959



New Mexican
Liability Program
*Lower Rates *Tender Included*
Short Term Policies Available
(800) 992-4443

www.marinersins.com

See Our Half-Page Ad In This Issue

Newport Beach, CA - San Diego, CA
Burlingame, CA - Seattle, WA
Sarasota, FL - *Puerto Vallarta, MX

*Affiliate company of the Mariners Insurance Mexico

Best Marina in Banderas Bay



MARINA RIVIERA NAYARIT

www.marinarivieranayarit.com

011-52-329-295-5526

BLUE LATITUDE PRESS

The best cruising
information for the Sea
of Cortez and Pacific
Mainland Mexico

WWW.BLUELATITUDEPRESS.COM



New Sails
and Sail Repair

(619) 226-1133

www.UllmanSailsSD.com

BROUGHT TO YOU BY THESE OFFICIAL SPONSORS



La Paz Hotel Association
 Welcomes you to La Paz,
 Enjoy our Baja Ha-Ha
 Beach Fiesta
 November the 20th
 011-52 (612) 122-4624
www.golapaz.com



OPEQUIMAR
 MARINE CENTER CENTRO MARINO

A Full Service Boat Yard in Puerto Vallarta
 88 ton Travelift • Parts • Service • Repairs
 011-52 (322) 221-1800 www.opequimar.com
info@opequimar.com



OCENS

Weather, Email and
 Voice Solutions.
 Satellite Phone Sales
 and Rentals.

www.ocens.com
sales@ocens.com • (800) 746-1462

SAN DIEGO BAY'S



HARBOR ISLAND WEST MARINA
 Serving Southbound Cruisers in San Diego
 Bay for over 40 years
www.harborislandwestmarina.com
 619.291.6440
CALL ABOUT OUR BAJA HA-HA CRUISER SPECIAL!

CHANNEL ISLANDS MARINA & VINTAGE MARINA



For info on our
 exciting slip
 incentives call
 805.984.3366.



**Mexico Boating
 Guide** Capt. Pat Rains

Covers every mile - no fluff!
 Pacific Baja
 Upper Sea of Cortez
 Lower Sea of Cortez
 Gold Coast
 Costa del Sur **New 3rd Edition
 2012**
www.MexicoBoating.com

IMPORTANT DATES

Although 2013 dates have yet to be announced, a look at this year's schedule (below) will give you a good idea of next year's timing.

- Oct. 20** — Ha-Ha Welcome to San Diego Party, Downwind Marine, 12-4 pm. Ha-Ha entrants only.
- Oct. 27** — Pacific Puddle Jump seminar, West Marine, San Diego, 5 pm.
- Oct. 28, 9 am** — Final deadline for all crew and skipper waivers, West Marine, San Diego.
- Oct. 28, 11 am** — Skipper's meeting, West Marine, San Diego. Skippers only please.
- Oct. 28, 1 pm** — Ha-Ha Halloween Costume Party and Barbecue, West Marine, San Diego.
- Oct. 29, 11 am** — S.D. Harbor Parade and Start of Leg 1
- Nov. 3, 8 am** — Start of Leg 2
- Nov. 7, 7 am** — Start of Leg 3
- Nov. 9** — Cabo Beach Party
- Nov. 10** — Awards presentations hosted by the Cabo Marina.
- Nov. 20, 4-7 pm** — La Paz Beach Party. Mexican folk dancing, live music, & more.

See www.baja-haha.com for a list of additional seminars and special events held by our event sponsors.

Baja Ha-Ha, LLC
 c/o 15 Locust Ave., Mill Valley, CA 94941
WWW.BAJA-HAHA.COM

PLEASE NOTE: Correspondence relating to the event can be emailed to andy@baja-haha.com. Please don't call *Latitude 38* with questions. The Ha-Ha is a separate operation.



MARINA DE LA PAZ
FULL SERVICE MARINA
 Conveniently located downtown
 Tel: 011-52 (612) 122-1646
 Fax: 011-52 (612) 125-5900
 email: marinalapaz@prodigy.net.mx
www.marinelapaz.com



BLUE PELICAN MARINE
 National Commitments

Located at Grand Marina Dealer for Lavac Marine Toilets
www.bluepelicanmarine.com
(510) 769-4858

*A Sailor's
 Consignment
 Chandlery*

SAN DIEGO'S RIGGING CENTER
 Proudly serving for over 25 years



PACIFIC OFFSHORE RIGGING

We'll get you ready for your next sailing adventure!

Design consulting • Commissioning • Refits
 Custom line and hardware

(619)
WE SHIP RIGGING WORLDWIDE
www.pacificoffshorerigging.com **226-1252**



Cruise RO Water
 and power

Go Cruising, Not Camping, with High Output Water Makers, Alternators, and Power Products.
www.cruiseROwater.com



Charlie's Charts
 Cruising Guides & More!

Now, the most accurate Navigation Charts of Baja and the Sea of Cortez by Gerry Cunningham have joined the most well known and beloved Cruising Guides of Mexico, the U.S. West Coast and beyond... *Take our combined 70 years of Mexico cruising experience along on your adventure!*

GERRY SINCE 1973
 BAJA & SEA OF CORTAZ NAVIGATION CHARTS
www.charliescharts.com

FISHERMAN'S LANDING - SAN DIEGO



Tackle Shop

Your source for the most extensive line of saltwater fishing tackle, lures, rods and reels available!
(800) 566-0273
www.saltwatertackle.com

THE LATITUDE 38 INTERVIEW

Webb Chiles

We've never quite known what to think about sailor and author Webb Chiles, who turned 70 in November. It's impossible to deny his body of work as a sailor. He was the one who broke Sir Francis Chichester's singlehanded non-stop around the world record — and with an Ericson 37 — and has singlehanded (mostly) around the world a total of five times without sponsorship. But there are also things that make some sailors think he's a little outside the mainstream. For instance, there's a couple of weird boat names and the business of singlehanded around the world in an 18-ft open boat. And some people have told us they thought some of the things he's written in his books are a little . . . well, curious. The fact that he's been married six times has raised some flags with women.

When we found out that Chiles had acquired a 24-footer and was planning to singlehand her around the world, and would be in San Diego just before the Ha-Ha, we were eager to meet him. We found him to be a pleasant, intelligent, confident, independent and self-reliant man from the Midwest with a true passion for shorthanded ocean sailing. These are the highlights of our conversation.

Latitude 38: Tell us a little about your new boat.

Webb Chiles: She's a Moore 24 ultralight hull #40 that I've named *Gannet*. I've owned her for about 18 months, but as I live in Evanston, a suburb of Chicago, it's cold in the winter, so I haven't been able to sail or work on her all that time.

38: Why a Moore 24?

WC: One factor is her reputation as a great sailing boat and a great sea boat that will take you where you want to go and bring you back. I also like the hollow bow, the slight reverse sheer — everything about the flush deck version. I don't like the later ones with the tiny house.

I started out thinking that I wanted a small boat to sail on Lake Michigan. But the truth of the matter is that I could just never get used to being a lake sailor, even on the fifth biggest lake in the world. So when I bought *Gannet*, I knew in the back of my mind that a number of Moores had been raced singlehanded to Hawaii, and that she's a proven seaworthy design. So my Moore is coming back to California and the ocean — by way of Texas and Lake Superior.

38: Did you get a good deal?

WC: I paid \$9,000, plus \$1,000 for a trailer I'm selling to a guy from Northern California later today. I usually buy boats and fix them up, but this one was in really good shape for sailing around the buoys. Nevertheless, having owned sailboats for 50 years — my first one was an Excalibur 26 that I bought new in Berkeley — I'm still surprised at how much money I have to put into them to get them ready for singlehanded ocean sailing. In the case of the Moore, I've added a carbon fiber bowsprit and some thin, flexible solar panels. But I still have some major things to do, as I'll probably replace the mast and boom, perhaps get a new rudder, and install a self-steering vane that was given to me by a fellow sailor who developed health issues.

38: Has there been a different rationale for each of your circumnavigations and boat choices?

WC: After I used the Ericson 37 *Egregious* to break Chichester's record, I sold the boat and a book about my trip, and looked for a boat that was qualitatively different. That's when I came up with the idea of going around in *Chidiack Tichborne*, an 18.5-ft Drascombe Lugger. I started that voyage from this same Driscoll's Boat Yard in Mission Bay, San Diego. After a couple of years, I found myself in Saudi Arabia with a broken rudder. When I came into port, they arrested me as a spy, which is how I ended up spending several weeks in Saudi Arabian

prisons. I never did get that boat back.

It's a little confusing, but about that time my grandmother died and left me a house here in Mission Bay, so I had enough money to go to England, where boats were much less expensive at the time. There I bought *Resurgam*, a really nice S&S 36 that was going to be my residence. But the manufacturers of the Drascombe Lugger built a replacement boat for me and shipped it to Egypt. Thus I was able to retrace my steps back to Saudi Arabia so I could complete my circumnavigation. I ended up doing a circumnavigation on *Resurgam*, too. She later sank off Florida, which is how I came to be swimming in the open ocean for 26 hours before being rescued.

When I give talks, I always point out that small boats are more cost effective than big ones. For example, *Egregious* cost \$40,000 in '70s money, and would do about seven knots. The 18.5-ft Drascombe Lugger cost much less, but would still go five or six knots. In fact, I once did 300 miles with no boat at all. [Laughter.]

38: Let's back up a minute. What caused *Resurgam* to sink?

WC: It's a long, personal and very painful story, so people will have to read about it in my book. But it was all my fault.

38: Can you explain the "300 miles in no boat"?

WC: Well, the Lugger filled with water once, and we had to drift to safety.

To continue my boat history, less than a year after *Resurgam* sank, I took all the money I had left and bought *Hawk*, a Heritage One-Tonner in Lake Champlain. I needed a home. I motored her down

to Florida, where I met my present wife. I've been married six times to five women, so [laughter] I need to complete a sixth circumnavigation to even things out. But I used *Hawk* for my fourth and half of my fifth circumnavigations.

38: Many sailors think that IOR and Ton rating boats are pretty awful because they were designed to beat a rule rather than sail fast, and because their pumpkin seed shape makes them difficult to handle when sailing downwind. What's your opinion?

WC: Well, I've set world records with them. They may be hard to handle if you push them hard downwind in strong breezes, but when you're sailing alone, you don't push that hard. When singlehanded, the limiting factor tends to be the self-steering vane. I sailed around the Horn with *Egregious*, which was an IOR shape, and with Jill on the S&S 34 *Resurgam*, which was

"I've been married six times to five women, so I need to complete a sixth circumnavigation to even things out."

roughly the same design concept. I didn't have a problem with either. The key is to sail with whatever boat you have.

For my fifth circumnavigation, with the Heritage One Tonner *Hawk*, I just wanted to go sailing, and was back in 18 months. I actually ended up racing my own time — from when I sailed *Egregious* and beat Chichester's time, just over 200 days — and I beat it. But by then the single-handed circumnavigation records had been creamed. *Hawk* ended up on a mooring in Opuia, New Zealand. That's as good as place as there is in the world to have a boat on a mooring. Opuia is beautiful, the sailing is wonderful, and the people are great.

38: *Were any of the boats more difficult to go around in than the others?*

WC: The unbalanced 900-lb *Chidiack Tichborne* was a true open boat, so that was an entirely different experience. I never wanted a small boat just because it was a small boat. There's a guy building an egg-shaped 12-ft "ocean-going boat." What will she do, two knots? Well, that's not sailing, that's drifting. When *Chidiack* flipped between Fiji and Vanuatu, she remained gunwales deep with water that I couldn't get out, so I pumped up my inflatable and got into it, and we drifted 300 miles together at one knot. But that's not sailing.

Chidiack was a good boat. After I left San Diego, I made the Marquesas in 34 days, which was only two or three days longer than it took most 40-footers. My best run with her was just under 150 miles — and I count noon to noon, not just the best 24 hours. Yawl rigged, she was the best boat I've had for heaving to. She had a furling jib — my first one because they were new then and I didn't trust them — so all I had to do to heave to was furl the jib, drop the main, and flatten the mizzen. All of which I could do from the cockpit. I had to heave to once during my attempted 4,000-mile passage from Singapore to Aden. I'd gotten into a blow, and while hove to averaged three knots backward!

38: *Did you have engines on these boats?*

WC: *Egregious* and *Chidiack* didn't, but *Resurgam* and *Hawk* had two-cylinder diesels that I used for making electricity. Dur-

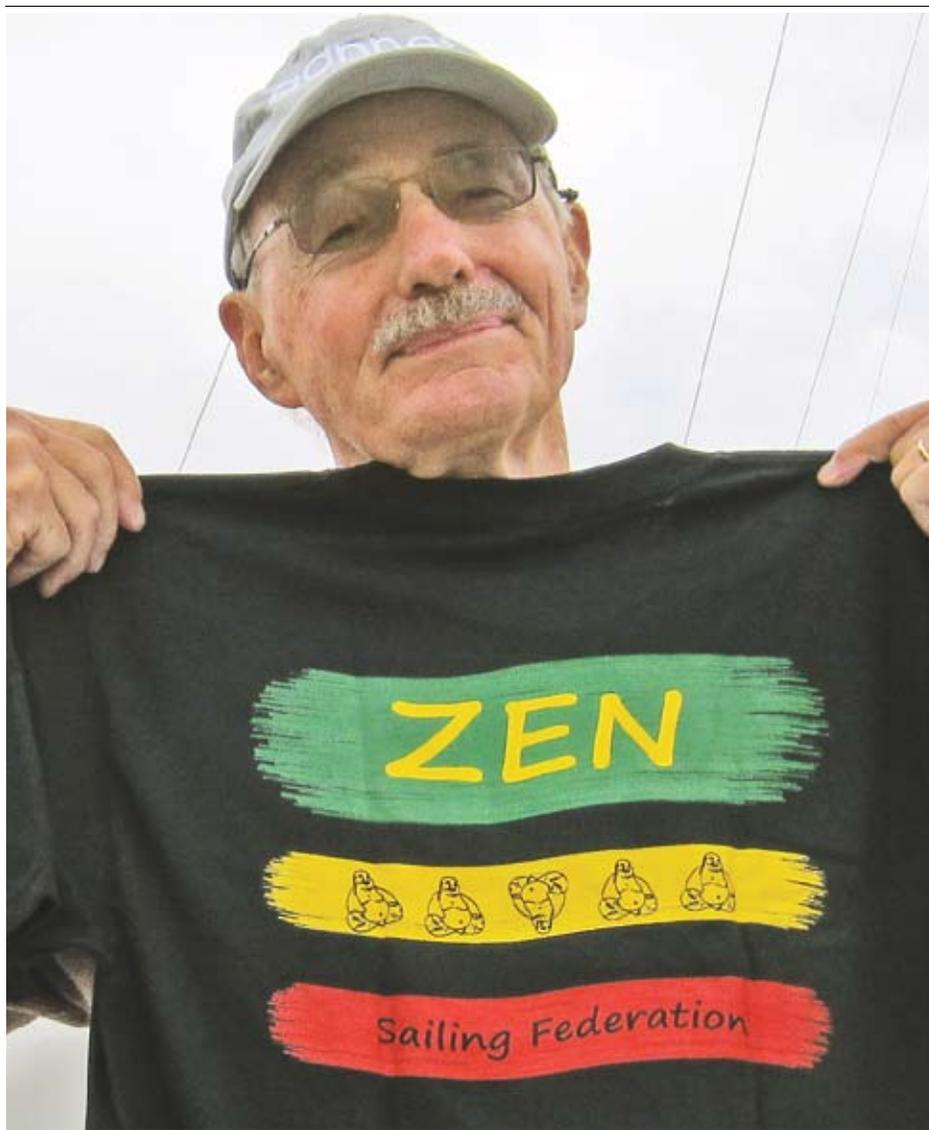

ing my fifth circumnavigation, I used a total of 40 gallons of diesel, and that included my transit of the Panama Canal. My attitude toward electricity is to reduce consumption, not increase the capability to produce more. That's why I've never had refrigeration on any of my circumnavigations. Running an engine every day to keep things refrigerated would ruin my whole experience of being out there.

These days most of the world's ports are set up for vessels with engines, which is why I have a small electric motor for *Gannet*.

38: *Your bike is your means of transportation in San Diego. You're lean and look fit. How is your health?*

WC: It's good, although I have gone blind in one eye. It's a combination of a detached retina, which was surgically repaired, then

glaucoma. It's not clear whether the eye will ultimately have to go.

38: *When do you plan to leave San Diego?*

WC: I was going to leave San Diego in June, but I have history in San Diego, and I'm finding that I quite like it here. So now I'm thinking I may take off a year from June instead of this coming June. I'm about to turn 70, so there's always a chance I won't be around a year from June. But either I'll have time or won't have to worry about it.

38: *Has anyone gone around more times than you?*

WC: A Japanese man has. But nobody has gone around more times who hasn't been sponsored or hasn't raced around. I have no shore teams and get no assistance.

My motivation is that I just love ocean sailing. For example, I'm going to go sailing tomorrow [*the forecast was for rain*] and I'm going to go sailing around something. Maybe Catalina. I'm not going to stop there, I just want to sail around something, then have a nice downwind sail back to get a better feel for the Moore.

38: *You're a Zen sailor!*

WC: It's funny, but lots of people who sail don't really like sailing that much, or even being on the ocean.

But with regard to the itinerary, I'll probably start by sailing to Hawaii. I've already gone around westward three times,

the latitude interview:

and I don't really want to do that again. Plus, how would I get through the Panama Canal unless I could be towed? Twice I've gone east around Cape Horn. Whether *Gannet* would survive down there, I don't know. And the Northwest Passage isn't what it once was, so I don't know. This is the first time I won't have had a definite plan before I leave. But I'm again looking for a qualitatively different experience. At some point I expect to be sailing with gale force winds on the beam, and will be sailing faster than I've ever sailed on a monohull before.

38: *What's the fastest you've gone so far?*

WC: I was in a 55-knot storm with *Chidlock* and pegged the speedo at 10 knots, and did the same in a Levanter near Gibraltar. The boat was probably travelling at 15 knots, something she wasn't made to do. With my other boats, I probably got up to 12 knots in the Southern Ocean. But *One Tonners* pretty much top out at eight knots.

38: *What will you have for a sail inventory?*

WC: For many years my boats have had three sails — a furling jib, an asymmetrical chute, and a fully battened main. I'm having new sails built for *Gannet*. I'll have a traditional spinnaker and storm jib in addition to the furling jib and fully battened main and asymmetrical spinnaker.

38: *What will you use for communications?*

WC: Just a handheld VHF. I don't want to talk to anyone who isn't on my boat. When I'm out at sea, I never communicate with anyone. I just have the handheld to talk to officials in ports to find out where they want me to go.

38: *Interesting. Lots of singlehanded sailors — even ones who stay in radio communication with others — hear locomotives on the open ocean, see bears on their boats, and have other hallucinations caused by a shortage of normal sensory input. What about you?*

WC: During my first time going around, I remember hearing the voice of one of the women in my life. But no, I'm used to being alone. I enjoy my own company.

38: *Speaking of women in your life, how is it you've been married so many times?*

WC: I like women, women like me. [Laughter.]

38: *Are you concerned about being hit by ships because you won't have radar or AIS?*

WC: Those things aren't going to keep you out of danger. When you sail out of here on the California coast, on Lake Michigan, or around the Med, ships can come from all directions, and the risk of getting run down is serious. But if you get 30 miles offshore of most places — including New York City — you're no longer in danger of getting run down. Nobody else is out there.



Moore 24s are known for their spacious interiors and three-foot headroom.

38: *Do you wear a harness?*

WC: Not usually on the other boats. I'll have one aboard *Gannet*, and I may wear it more. But because I can set and douse all my sails from the cockpit, I won't have to go on the foredeck much. The big fear when sailing alone is that something goes wrong in the middle of the night, the boat is out of control, and you have the spinnaker up. With my sail plan, I can douse the gennaker from the cockpit, so I really won't have to go forward.

38: *How do you get your weather?*

WC: I look around at sunset, checking to see if there are any changes in the sky or sea. I've had some false positives, but in all my decades of ocean sailing, I've never said 'It's going to be okay tonight', and it wasn't. I look for changes in the patterns in the sky, in the wave heights, and things like that. And I look at the barometer.

So many sailors look for weather windows, but there is a certain satisfaction in having survived a number of Force 12 storms — the maximum on the Beaufort Scale — confident that you'll be all right. I have been in Force 12 winds, always in the Southern Ocean except for once in the Tasman Sea just north of 40°S. I took knockdowns with my 36-footer and both my 37-footers so that all the masthead gear was washed off.

38: *What's the key to surviving a Force 12 storm?*

WC: Lots of sea room. [Laughter.]

38: *What was it like being in a One-Tonner in a Force 12 storm?*

WC: Much of the time was all right. The key is whether a wave breaks at the exact instant it hits your boat and flips you over. If the wave has already broken, you get foam all over the boat, but it's not so bad.

38: *Hank Grandin and son got rolled in a hurricane sailing across the Atlantic in an Olson 30, and Doug McNoughton got rolled in an Atlantic hurricane in, if we remember correctly, an Express 27. They both survived.*

WC: That's cause for optimism. I think being rolled in a Moore 24 would be all right. But having the boat picked up and tossed a long way by a breaking wave would be different. But there are virtues to small boats, as the curves are stronger.

38: *What will you navigate with?*

WC: My iPad is my chartplotter. I use iNavX. You can get some Navionics charts for it, as iNavX has all the NOAA charts, but you need to buy the stuff for outside the United States.

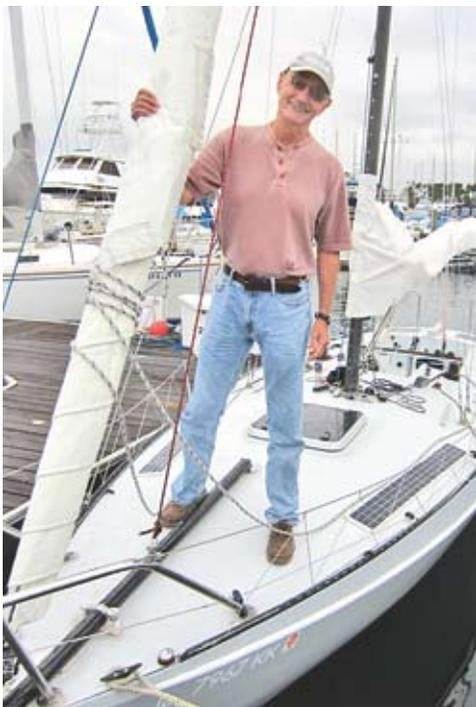

Webb loves to sail the ocean just to be sailing.

webb chiles

But it's inexpensive compared to when I used to use C Map, where it was \$250 per region for charts. I bought the iPad to use as a chartplotter, but I've found that it's useful for so many other things. I can do all I need without a full computer, except update my website and a little of my finances, at which point I have to visit a Starbucks.

38: *The Moore is a very small boat. What's going to be worse, being inside or outside?*

WC: I'm not sure, but it's going to be the heat. I like dark color hulls and wanted a black Moore 24, but it would have been too hot. I haven't had *Gannet* in the tropics, but I had it on Lake Michigan when it was in the '90s. It was hot.

The problem with the Moore is not my ass, but my back. My favorite place on the boat is sitting on the floorboards, facing aft. I have access to everything. One of most comfortable positions is standing in the companionway. There is no ladder, and with a flotation cushion against my hip, it's very

comfortable and I can reach everything. It's like wearing the boat.

38: *What about exercise?*



Webb's bicycle is almost bigger than the boat he plans to circumnavigate.

WC: I have a workout that includes push-ups, crunches, knee bends. It takes about 15 minutes a day. I did it on the Moore last week. I have to improvise, but I can do it.

38: *What did you do for a career when you weren't sailing?*

WC: I stopped working for other people in '74. I've always thought of myself as a writer, and I managed to support myself that way.

38: *What does your current wife think of your wanting to circumnavigate on a Moore 24?*

WC: My wife Carol is very intelligent — an architect — and a very good sailor. She

thinks I'm going to get killed.

38: *It's easy for us to say, but if you take the tradewind route, we think you and the Moore will do just fine.*

— **latitude** / richard

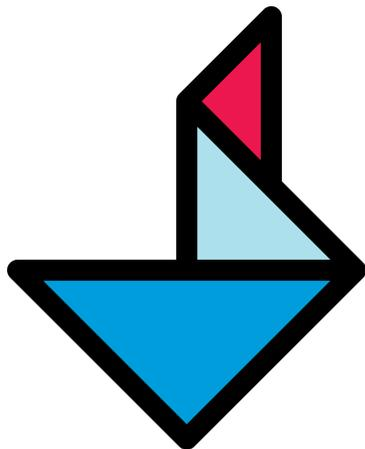

**SAN FRANCISCO
BOATWORKS**

San Francisco's boatyard | sfboatworks.com

Marine parts and supplies



Complete haul and repair



Engine repair and service



**Contact us for seasonal
discounts & special offers**

Authorized dealer for:

YANMAR

**marine services
for power & sail**

415.626.3275

info@sfboatworks.com

835 Terry Francois St.

San Francisco, CA 94158

SEASON CHAMPIONS, PART I —

Thanks to the arrival of the America's Cup World Series road show this year, San Francisco Bay has drawn the attention of both national and international sailing aficionados like never before. And more of the world's most accomplished helmsmen, tacticians and crews raced on Bay waters this year than we can ever recall.

As cool as all that was, though, those visiting pros never stole the thunder of the diehard racers that you'll meet in these pages — the Season Champs of a wildly diverse number of one design fleets. Many have been campaigning their winning boats for years, if not decades. And as much as they might enjoy the novelty of a ride on an AC45, we'd bet most of them would not trade that scene for the camaraderie they feel within their own cadre of racing opponents.

There are so many classes here on the Bay that it will take at least two installments of this tribute to honor them all. In contrast to the ultra-high-tech AC72s that are now plying Bay waters in advance of next summer's America's Cup 34, we'll start our winner profiles this month with some of the most venerable yet well-loved design classes. (Look for Part II next month.)

WBRA Bear — *Smokey* Steve Robertson

Regular crew: Josselyn Robertson, Henry Englehardt & Jeff Harriman



Steve Robertson

Steve Robertson has no clue how many times he's won a Season Championship. He simply never keeps track, but he guesses it's probably close to 20 in various classes, and in the Bear. . . well, probably over 10.

BAY RACING ALPHABET SOUP

HDA = Handicap Divisions Association (Bay racing using the PHRF handicapping system); ODCA = One Design Class Association (Bay racing for one design fleets); OYRA = Offshore Yacht Racing Association (ocean racing using displacement/waterline divisions sailing under PHRF); WBRA = Wooden Boat Racing Association (Bay racing for the following wooden one design fleets). Additional fleets are one design or otherwise independently administered.

"I don't know! I don't even keep trophies!" he laughed.

Robertson's been sailing all his life, and has owned and raced *Smokey* off and on since 1966. After 47 years on the boat, he attributes his success to the racing on San Francisco Bay, the competition, camaraderie and probably *Smokey*. "We have a great crew and a fast boat," he said.

He claims winning this year was just

"On the first day we broke the whisker pole on a badly timed jibe — totally my fault."

like any other, "We just went out and did what we always do: try to get a good start, stay out of trouble, and sail fast. The Bear fleet has a lot of good sailors, and this year the most competitive sailors were Glen Tresser and Peter Miller.

Robertson sailed 20+ races this year. He likes to sail year-round, although he says he races mainly in summer. Either way, after more than half a lifetime with the same boat, it's clear he really likes *Smokey*.

"I love the Bear. It's the perfect boat. It's five minutes from my office, I can sail it alone, I can sail with a crew, we can cruise it. Boats are really expensive, right? But a 23-ft boat costs a hell of a lot less than a 30-ft boat."

WBRA Bird — *Curlew* Bill Claussen

After racing all his life — both crewing and skippering — and a 20-year



Bill Claussen

hiatus wind-surfing, Bill Claussen said it was great to be racing again, and in the Bird class. His success this year in such an established class is even sweeter as he's been racing *Curlew* for only a year and a half.

"I used to watch them as a kid racing with my dad," Claussen said. "I'm also involved in restoring another Bird, which

has been a fun project. I'll be looking to charter her next year."

Claussen loves racing *Curlew*, as he says, "nothing sails like a Bird! She's easy to sail, it's a great fleet that's making a resurgence, and the competition is fun — as is sailing in the oldest racing fleet on the Bay."

He credits his winning formula this year to a great crew: Carl Fleming, Chris Klein, John Mara, John Ravizza, John Skinner, Jim Lindsey, and John Buestad, as well as to having a good boat, good speed and not making too many mistakes. Expect to see Claussen back on the water on *Curlew* next season.

WBRA Folkboat *Josephine* Eric Kaiser

Regular crew: Patrick Morgan & Kurt Hemmingsen

Dropping the keel on *Josephine* last January may have had something to do with Eric Kaiser's winning performance this season: he discovered that the keel was actually bent and twisted off to port. Aha!

"After much grinding, filling and fairing of the keel and the entire hull, we finally had a bottom that resembled that of a race-worthy boat!"

After five seasons on the Bay, Kaiser says a combination of factors helped him succeed: consistent crew that worked on the boat with him in the off season, Doyle Sails, and no flyers on the race course.

"Maintaining positive talk on board and making good decisions as far as minor adjustments to the rig and jib leads as the conditions changed (thank



LATITUDE / ANDY



Eric Kaiser

LATITUDE / CHRIS

WOODIES & ONE DESIGNS



Smokin'! The venerable Bird boat 'Curlew' flies across the Central Bay during the recent Jessica Cup Regatta. "Nothing sails like a Bird."

you Kurt) helped us."

A pivotal moment for Kaiser was winning the fleet's annual Woodies Regatta. "Somehow that regatta win gave the team a great deal of confidence, Kaiser said. "On the first day we broke the whisker pole on a badly timed jibe — totally my fault — and we used the spare pole my dad made out of wood some 25 years ago. I mostly carry it on board for sentimental reasons, but that day it kept us in the hunt.

"Right after we hit the dock, we raced over to Svendsen's and went to work building a new pole. It was a team effort, and in the end proved to be a difference-maker not only because we worked together to make it happen, but also because we increased the length of the pole 6 inches, something we had talked about earlier in the season as a difference between us and the other boats."

The cast of characters in the fleet keeps Kaiser racing, and he's not sure he'd be racing if that weren't the case. "We really love to beat each other out on the race course, but we're also good

friends off the water."

WBRA Knarr — Fifty/Fifty Brent Crawford

Regular crew: John Bobincheck (co-owner), Tim Wadleigh, Dan Ahern, Steve Wegner & Scott Sullivan



Brent Crawford

personal time to work on the boat and get it ready to race played a big part in getting to the top quickly," said Crawford.

"We replaced the old wood mast with the new aluminum mast, installed all new rigging systems, relocated the winches, installed new beer holders,

and did lots of sanding and varnishing."

It also helped that every *Fifty/Fifty* crew member committed to every San Francisco Bay race on the calendar.

"Our original goal for the year was to qualify for the International Knarr Championship in Copenhagen," Crawford explained. "The IKC regattas are absolutely incredible with 12 days of world class parties and some fun sailing too. Mission accomplished."

He considers the team ritual of drinking premium tequila before the start of every race, and cold beers at the finish line was key to their tenacity after ten long months of racing.

"Our defining moment for 2012 was when our team won the SFYC Fall Classic. After 50 races on SF Bay and 15 races in Denmark, my crew was still excited to get out on the water and give their best effort. That level of commitment and enthusiasm for ten straight months was just incredible. Consistency wins championships."

In 2013 the International Knarr Championship (IKCs) will be held at the San Francisco YC and Crawford expects every U.S. team will be giving a 100% effort to qualify in the first half of the season (April to June). "Regardless of how we finish, Team *Fifty/Fifty* will have fun."

WBRA IOD (Internat'l One Design) Fjaer

Rich & Mark Pearce

Brothers Rich and Mark Pearce have campaigned *Fjaer* for four years and claim that their acumen on the water this year is thanks to consistency and a committed crew: Paul Zupan, Scott Lynch and a host of future rock stars



Mark and Rich Pearce

from the SFYC youth sailing program.

And if there's one thing that they learned this year, it's "Don't be OCS," as

LATITUDE / CHRIS

LATITUDE ARCHIVES

SEASON CHAMPIONS, PART I —

"it's never fast sailing backwards," Rich joked. "We've enjoyed some amazingly close and competitive racing this season. We are looking forward to more of the same next year. We have several new additions to the fleet and have crew positions available on any given weekend. It's an IOD; we love everything about it! Check us out at www.sfiiod.org."

He said the local IOD fleet is tough, with everyone having a shot on any given day. "The racing's been very exciting and very close, while each of the teams has been more forthcoming with their go-fast secrets."

Rich is excited that there's renewed interest in the fleet. "We're seeing interest from individuals and syndicates who like the one design rules, which limit sail purchases, provide for group purchase discounts, and ultimately limit the possibility of 'racing checkbooks,'" he said.

The Pearce family has sailed IODs for 50 years, said Pearce, during which time they've individually or collectively campaigned six different boats with various levels of success.

Etchells Fleet 12 — JR Bill Melbostad

Bill Melbostad named his Etchells *JR* after his dad, with whom he sailed most of his life. While consistent starts, above-average boat speed and good boat handling were key to winning this year, Bill says the single most important factor was his crew: Steve Fentress, Bill Barton and Mike Ruff.

"The Etchells requires good teamwork



Bill Melbostad

and a crew that is used to working together," he said. "Between Bill, Steve and Mike, the combined experience is about 40+ years in the boat. That's a lot of years in a particular one design class."

Melbostad's been campaigning this particular Etchells for seven years and has been active in the fleet off and on since 1980. He loves that Etchells racing is always close, with boats usually finishing within seconds of each other. "The boat is very tactical, and being smart on the water is rewarded," he said.

An "aha" moment? "Jibing the boat

in 25+ knots on plane and a wave, the boom floats over effortlessly and the boat is totally under control," Melbostad said. "That's good boat handling!"

The fun factor is also high on the list for Melbostad, with top moments this year including sailing the boat with family and friends in club races and the Leukemia Cup, winning both events.

Watch out for *JR* in 2013 — the crew intends to sail every race during the one design season, with the intent of repeating their win.

ODCA Express 37 — Golden Moon Kame Richards & Bill Bridge

This year is the third season championship for Richards and his crew on *Golden Moon*. The roster includes Tom and Eliza Paulling, Mike Mannix, Jason Westenburg, Brad Jeffry, Jeff Angermann, Chris Bridge, Sally Richards, Rebecca Hinden, Todd Hedin, Chris Boome, Aimee Daniel, Robbie Englehart, and others.

"They're a great group who want to

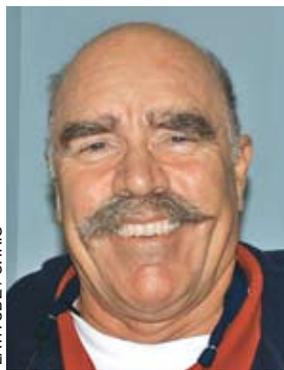

Kame Richards

constantly improve their skill level and don't complain about doing 10 or 20 jibes before the start of the first race every day!"

Richards loves being part of a one design fleet, citing that it's "the best sailboat racing available," particularly when racing against Mick Schlens on *Blade Runner* (of Southern California). "We have had a great time sailing against each other," said Richards. "He's a terrific competitor, and a joy to be with on and off the water. They sail the pants off their boat. The last time they came up for the Big Boat Series they got second. This year, we got second. Leading going into the last day just isn't good enough. You've got to be leading at the end of the last day, which is what Mick did!"

After all's said and done, and having campaigned his boat for ten years, Richards says that sailing the Estuary Wednesday Night Beer Can Series is in fact more rewarding than anything else he and his crew do.

"We get new people out on the water,



DANIEL FORSTER / ROLEX

sometimes for the very first time. We introduce people to sailing and racing and try to show that paying attention and concentrating on the job at hand yields big benefits."

ODCA Santana 22 — Santa María Chris Giovacchini

Regular crew: Ted Wray & Nelson Bellesheim

If there's one aspect of racing that is



Chris Giovacchini

undeniably transparent across all boats, racers and fleets, it's that without a good crew you may as well go sink your boat. Chris Giovacchini on his Santana 22 *Santa Maria* claims that his secret to success this year was his outstanding crew, Ted Wray and Nelson Bellesheim. "They're dedicated and tenacious," Giovacchini reported.

LATITUDE / CHRIS

WOODIES & ONE DESIGNS



Nothin' to it. Longtime Express 37 racer Kame Richards drives confidently from the rail during September's Rolex Big Boat Series.

Chris has been campaigning his boat most recently since 2010, and plans to do it all over again next year with his same crew of "devils." Given that he also reports that most of his experience is racing from behind — an assertion we strongly doubt — Giovacchini says it's always a highlight — and exciting — to catch up from behind.

"This did happen to us a few times! Once we rounded fourth at the leeward mark in a pack, decided not to follow, and caught them all at the finish by 50 yards for the gun. We were all pleasantly surprised . . . and happy!"

Express 27 — *El Raton* Ray Lotto

Regular Crew: Steve Carroll, Patrick Lewis, Jordan Paxhia & Noe Goodman

This was Ray Lotto's third year winning the Express 27 Fleet San Francisco Championship Series and San Francisco Long Distance Series on *El Raton*. He says "excellence and consistency" were the secret behind his success.

Ray started racing *El Raton* in 1988, and for the last five years he's raced the

boat seriously with Steve Carroll, Patrick Lewis, Jordan Paxhia and Noe Goodman. "I've been racing *El Raton* with Steve for nearly 20 years," Lotto explained. "He's



Ray Lotto

like family, and he's one of the best sailors on the Bay. Patrick is excellent on foredeck and Noe keeps everything together. It is always good to have a woman on the boat. And Jordan is not only a top sailor in every respect but adds a great attitude."

A defining moment for *El Raton* was The Delta Ditch Run this year with winds gusting 30 to 35 knots from the west. As Lotto described it, "When we have a spinnaker run we pride ourselves on not having roundups. But on this race we had four roundups and one rounddown when the spinnaker pole went into the water and was bent. Patrick took the

slats off the benches down below and taped them to the spinnaker pole, which made a brace so it could be used. There were many dirmastings on that race." Nonetheless, *El Raton* scored first in the Express 27 Fleet and fifth overall.

Ray thanks Peggy Lidster, Express Fleet Captain, who has built up the fleet with tireless work, and adds that his shore crew Janet Lotto and Annie Carroll are the welcoming committee who greet them on the dock with Dark & Stormy cocktails whether they're crying or celebrating.

Laser — *Christine Robin* Tracy Usher

Tracy Usher bought his first Laser, #17586, in 1974, took a bit of a break from Laser sailing in the 1980s to deal with an education and career start, then got back into it in the early '90s.

After living in age denial for a few years (foolishly missing the legendary Cancun Masters' Worlds, he says), Usher finally attended his first Masters' Worlds in '01 and he's been to every one since. During this time he's been through seven boats, including his current one, #199187.

Recalling a memorable moment, Usher says that in the late spring his weight went below 190 pounds for the first time in about 15 years.

"I discovered that Peter Vessella (among others) wasn't flying by me downwind anymore — and I wasn't giving much away going upwind. I said, 'Aha! This diet thing might actually be worthwhile!'"

Locally, he says the Laser has a great fleet with a mix of seasoned veterans (i.e. old people), and many up-and-coming youth sailors, including sailors in both groups with plenty of experience at the international level. "It's interesting that the young sailors don't always win!" said Usher.

Besides the local district schedule, Usher's 2013 racing plans include the Masters' U.S. National Championship at Cabrillo Beach, the Pacific Coast Championship in the Columbia River Gorge, and the Masters' World Championship at the end of the year in Oman. "Next season" starts this month at the RYC Small Boat Midwinters!

Laser Radial *Desperate Laserwives* Christy Usher

Christy Usher calls her Laser Radial *Desperate Laserwives* because, she says,

LATITUDE ARCHIVES

SEASON CHAMPIONS, PT I

behind every Laser Master sailor is a desperate Laserwife!

"DLWs are (the best) part of the Laser Master sailing lifestyle," Usher explained, "The term desperate Laserwives was coined by a group of us ladies at the Laser Masters' Worlds in Brazil in 2005 while lounging by the pool drinking Caipirinhas. At a Masters' Regatta, if the DLWs aren't sailing we're either lounging poolside, lunching, touring or shopping."

Usher's winning season seems a far cry from desperate. She's been sailing Lasers since college, but it wasn't until recently when she turned 35 that she joined husband Tracy on the Laser Masters' circuit and started racing the Radial more often.

The sweetest moment for her on the water this year was winning a race at the Masters Pacific Coast Championship to the cheers of her competitors.

"I rounded the leeward mark to the finish in first place (from fourth at the windward mark), and as I sailed to the finish line all the guys behind me were cheering me on. They were just as excited



COURTESY USHERS

Christy (left, the 'desperate Laserwife') and Tracy Usher show their winning form during a bouncy day on the Bay.

to see me win that race as I was! It was a very special moment for me and one I'll always remember."

She claims that what keeps her coming back, regatta after regatta, is the mental and physical challenge of racing a Laser, reconnecting with dear friends,

making new friends, and seeing so many new and fascinating parts of the world.

We'll take a breather here, but pick up where we left off next month, with more accolades to the Bay Area's finest sailors. Don't miss it.

— **Michelle Slade & Latitude/Andy**

COME VISIT COYOTE POINT MARINA

The Peninsula's Complete Recreational Destination!



BERTHING

- Slips to 40' available
- Inside ties from \$100 per mo.
- Multihull side ties available
- Check out our rates!

FUEL DOCK & PUMP OUT

- Open 7 days per week
- Gas and diesel available
- Check our prices
- Free pump outs

Fuel Dock currently closed for repairs.

COYOTE POINT MARINA ~ 1900 Coyote Point Drive • San Mateo

650.573.2594



RACING



CRUISING

REINHARD WESTPHAL



SAILING

LATITUDE 38/LADONNA

Thank You

We are grateful to all our customers for making 2012 our best year yet!



Best wishes for the holidays!



Easom Racing and Rigging

1230 Brickyard Cove Rd. Suite 102
Point Richmond, CA 94801

See you on the water
in 2013!

(510) 232-SAIL (7245)
www.easomrigging.com

Bilge Steam Cleaning Oil Changes

Professional service at your slip!!!



MarineLube 877 744-2244

www.MarineLube.biz



Fuel Polishing

Tank Cleaning

Save Your Aft!



Using one of our 1900+ patterns or your own pattern, let our craftsmen create a comfortable, durable, and stylish set of all-weather cushions for your cockpit. Find your custom, closed cell foam cushions at www.bottomsiders.com!

BottomSiders

BottomSiders
2305 Bay Avenue
Hoquiam, WA 98550

Call Toll Free: (800) 438-0633
cushions@bottomsiders.com
Fax: 360-533-4474

HAWAII

LONG TERM DRY STORAGE

Clear Customs at our dock

GENTRY'S

KONA MARINA

HONOKOHAU HARBOR

156°1'30" W
19°40'20" N

TOLL FREE **888-458-7896**

www.gentryskonamarina.com

The friendliest boatyard in Hawaii



BAY MARINE DIESEL

Marine Inboard Diesel Repair
Surveys • Personalized Instruction

Cummins | Ford/Lehman | Hino | Perkins
Universal | Westerbeke | Yanmar



Marty Chin, Owner – (510) 435-8870
Email: Baymarinediesel@comcast.net

PASSIN' THROUGH

Fall is one of our favorites times of year in the Bay Area. Not only do the biting summer winds start to mellow, but cruisers from the Pacific Northwest — and sometimes beyond — pass under our iconic Bridge before continuing south. They come in all shapes and sizes of boats, all economic backgrounds, and all experience levels. Some are old salts, while others were newbies when they left. Of course, by the time they reach San Francisco Bay, they've endured the Oregon/Washington coastline and could now be classified as old salts themselves. Some are heading to Mexico for the season, others are on their way around the world.

We normally encourage readers to seek out these salty sailors when they see them in their marinas, but fate conspired to postpone the publication of this article until long after even the stragglers had passed through. We interviewed the six crews profiled here in late September/early October, and — with the possible exception of one boat — all have moved on long ago, with some having just completed the 19th annual Baja Ha-Ha (see page 76 for that story). But while their experiences might have expanded considerably since we met them, each has a unique story we think is still worth telling.

We met up first with our old singlehander friend Jim Kellam, a retired crane operator in the BC logging industry. Jim has sailed in three Singlehanded Trans-Pacs on his Spencer 35 *Haulback* — solo circumnavigating after the second — and he's told us on a number of occasions that he'd never sail with someone else. But, happily, he changed his mind when he met his new bride Janet, a retired business owner. They married in March — on the spring equinox — and set off from Vancouver, BC, in August on an extended cruise that may take them around the world.

Their having such a well-prepared boat, one might be fooled into thinking the Kellams didn't have all that much to do before casting off the docklines. Not

so. "I had my townhouse in Vancouver that was decorated just as I wanted," notes Janet. "I thought that's what my life was going to look like."

But then Jim asked her to go cruising with him, and she said yes. "We often ask each other what we were thinking, and we both have the same answer," says Janet, a wry smile turning up the corners of her mouth. "We were both thinking of me standing on the dock with a very small kit bag and a very big smile!"

The following months were spent clearing out the townhouse and prepping *Haulback* for extended cruising — including the addition of refrigeration and a watermaker (that sound you just heard was the collective gasp of disbelief from Jim's many Bay Area sailing friends). Of course, as Janet cleared out the detritus of her life — "I got rid of all my pretty things," she moaned — Jim made concessions of his own, such as finding some place other than the silverware drawer to store his toothbrush, toothpaste and comb. "What?!" he exclaimed when we burst out laughing at Janet's revelation. "It made perfect sense — it was close to the mirror and the sink!"

As for their future plans, they're minimal and very flexible. "We're just going to keep going round and round till we get dizzy and fall off," laughs Jim. "We don't have an end date. We're going to Mexico this winter [they just completed the Ha-Ha] and then we'll cross the Pacific." They plan to visit Australia and Indonesia and spend a year in Tasmania, but they insist they're not on a schedule. As Jim notes, when you're circumnavigating, "Your schedule becomes cyclone season."

Just down the dock from the Kellams in Alameda were their friends from Vancouver Mike Northup and Nancy Kettles on the C&C 115 *Defiant*. Mike and Nancy were the least experienced

crew we talked to but they were far and away the most enthusiastic. Their having suffered a knockdown during a southerly



"This isn't a flag, it's a trophy," say Mike and Nancy of *'Defiant's* tattered Canadian Maple Leaf.

gale off the Oregon coast, we wondered if they were second-guessing their cruising plans. "No way," they both cried. In fact, they couldn't stop smiling while recounting their adventure.

Where the Kellams had seen decent northwesterlies for their nonstop trip to the Bay, Mike and Nancy had southerlies on the nose the whole way for their nonstop hop. "We were between Cape Blanco and Cape Mendocino, and I was on watch when it happened," recalls Mike. "Both spreaders were in the water, and so was I." Thankfully he was tethered to the boat. "I remember thinking, 'Oh no, there's water getting into my foul weather gear!'"

When Mike went to check on Nancy, who was unhurt in the knockdown, he was wearing a gigantic grin. "He kept saying, 'That was so cool,'" Nancy laughs. "I was like, 'You're fucking nuts!'" Surprisingly, they sustained little damage — a lost winch handle, boat hook and BBQ cover, and a torn dodger.

This from a couple with admittedly no offshore experience. Mike has been sailing for years, but only in protected waters. When he met Nancy five years ago, they'd go out for mini cruises in the summer, but nothing long-term. "If you count up all the time I've been sailing off and on over the five years I've known Mike," says Nancy, "it'd add up to about eight months, if that. That gale was the first time I've been in anything over 25 knots of wind."

The couple — who retired, sold everything and moved aboard the day before leaving BC — joined *Haulback* during the Ha-Ha with plans to spend a year in



Janet and Jim Kellam on *'Haulback'*.

— PAST TENSE



The Gordon-Rein Family: Jen, Richard, Bruce and Carmen of 'Northern Passage'.

Mexico before joining the Puddle Jump. From there, it's anyone's guess.

Bruce Rein and Jen Gordon were each living on sailboats in New Jersey when they met 15 years ago. They have since moved to Seldovia, Alaska, where they were raising their two kids — Richard, 12, and Carmen, 10 — before they set out on a year-and-a-half long adventure aboard their 51-ft Kanter Atlantic steel ketch *Northern Passage*. Each has extensive sailing experience, including sailing their previous boat, a Columbia 36, in Kachemak Bay (the bay that leads to Anchorage), but they always dreamed about cruising with the kids.

To that end, Bruce took a sabbatical from his job as a telecomm engineer (Jen is self-employed, so she takes her job with her), and they rented out their house and set off into the Gulf of Alaska on July 9. "That was the worst part of the trip for me," says young Richard, of their entry into the notorious Gulf. "We had 15-ft breaking waves that first day," confirms Jen. "It was pretty harrowing."

But Carmen is quick to point out a highlight: a huge pod of whales — "Northern right whales," she and Richard note proudly — they spotted on their way from Eureka to the Bay. Jen says the kids' school provided textbooks for schooling, but they're also learning about their environment as they go along.

With just a little over a year left to go, their itinerary is packed. Having just completed the Ha-Ha, they have plans to head to Panama — as of this writing,

they were already closing in on Puerto Vallarta — and the Caribbean with hopes to make it as far as Cape Cod by next August. Regardless, they'll keep cruising "until the fun or funds are gone."

Barely out of the newlywed stage, Steve and Judy Danzenroth tied the knot four years ago after meeting through the Seattle Singles YC. Steve had been sailing since the '80s — Puget Sound, Vancouver Island, the Queen Charlottes (Haida Gwaii) — while Judy had cruised and raced offshore for years, racking up



'Code Blue's Steve and Judy Danzenroth.

an impressive 16,000 bluewater miles. Steve had bought *Code Blue*, a Caliber 40 LRC, new in '02 with plans to cruise her, so finding a first mate who loved to sail was serendipitous. Together, they've also chartered in Tahiti and the BVIs.

In preparation for their five-year (or so) cruise, the couple moved aboard last August, so they've got the boat pretty well sorted. Even so, Judy says, "We've got a lot of stuff and need to lighten up the boat. You just always take too much with you."

Code Blue sailed out of Port Angeles on September 20 and endured the nastiness you'd expect between Cape Blanco and Cape Mendocino. "It was blowing 35-40 knots," Steve recalls. "The only damage was the bow lights are now gone and three toilet seat hinges broke."

From the Bay, the couple were going to take their time getting to Mexico before jumping off to the Galapagos, the Marquesas and on to Oz.

You don't have to be a rocket scientist to build your own 62-ft custom steel boat, but it doesn't hurt. Okay, Oleg Bely isn't a *rocket* scientist; he's an astrophysicist, but close enough. The Frenchman left his home country in the early '70s to work as a researcher at a university in Brazil. His wife Sophie — who was, unfortunately, not aboard the day we dropped by — was also employed at the university. They quit their jobs to cruise the world aboard their 50-ft steel boat, conceiving and having their son along the way.

In the mid-'80s, the family — including their unborn daughter — took their first trip to Antarctica, and they were hooked. Over the last 30 years, the Belys have visited the icy continent at least once a year, though Oleg thinks it's probably more. Mementos of their voyages in the form of photos and paintings decorate their rich and spacious saloon.

A few years later, Oleg was offered a very good price for his boat, which allowed him to design and build one that would suit his new business: charters from Brazil to Antarctica. "It was a fantastic adventure, mainly because it finished very well," laughs a gregarious Oleg.

All told, the job took five, sometimes six, people 20 months, or a total of about 30,000 hours. "It cost less than \$150,000," he says, though he admits

Oleg Bely, with 'Kotik' crewmember Dalila.

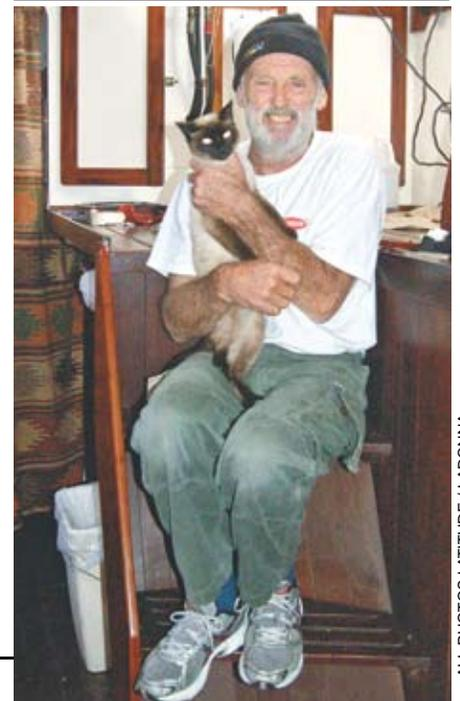

PASSIN' THROUGH

that government red tape and other issues could easily have killed the project altogether.

With their kids grown, the Belys left their homebase in Uruguay a year ago. "We like to go to the northern hemisphere every few years," he says. They wound their way up the Chilean Channels to the Galapagos, which they didn't care for, and on to Hawaii and the Aleutians, ending up in Dutch Harbor, Alaska, which they loved. From the Bay, their plan was to head to Mexico to have some work done on *Kotik* before hopping over to the Marquesas and Tahiti. While they're not on a schedule, per se, they do have another Antarctica expedition planned for January.

As for their business, Oleg points out that most of their income goes directly to maintaining *Kotik*. "The boat is first," he insists. "Besides, I don't want to get rich. I just want to live."

Karl Mayer disagrees with Oleg about Antarctica. "There are too many scientific stations, cruise ships and tour-



Karl Mayer and family (in photos) of 'Muktuk'.

ist boats for our taste," he says, speaking for his wife Alexandra and sons Gan, 8, and Noah, 5, who were also not aboard when we visited. The native Austrian has been cruising for the 22 years, the last 16 with Alexandra, so he knows what he likes.

Now on his sixth boat, a 47-ft steel Karoff design named *Muktuk*, Karl speaks well of the less-populated spots in the world and his desire to visit them. For

example, on this trip around, he really wanted to see Kodiak Island because they'd missed it the last time. Of course the shortest route from Europe to Alaska is through the fable Northwest Passage, so they just hopped on over to Greenland in May 2011. "The ice opened in front of us with a easterly breeze in August," Karl recalls. The trip through took about a month, and they spent the rest of the fall exploring Kodiak. They wintered in Sitka, leaving in April to explore Prince William Sound until July, when they made

their way down the coast.

Though the family have a rough idea of where they want to go from the Bay, they're not on a schedule, nor do they have a set itinerary. This isn't a 'trip' for them, this is a lifestyle. For now, the boys are using an Austrian curriculum for schooling, but Karl admits they may stop moving in five or so years to give them a chance to grow up with a stable group of friends. "But then we will possibly go again," he says "Cruising is life."

— **latitude**/ladonna

HOME TO EMERYVILLE SPORTS FISHING

Emeryville Marina

ON THE BAY

NEW SLIPS!
Now taking reservations for 40' to 60'

*When you call Emeryville Marina Home...
...call this your backyard!*

Free Wi-Fi and Video Surveillance

**Slips from 20-65 ft
Full Amenities - including
Fuel Dock & Pumpout Station**

(510) 654-3716
www.emeryvillemarina.com

MARINAS International

DeWitt

**A Wonderful Gift Is
ART!**

**Originals or
Giclée Prints –
to discuss, call Pam.**



*"Ducks in a Row" only available
as a Giclée Print.*

DeWitt Art Gallery & Framing

121 Park Place, Point Richmond, CA 94801

(510) 236-1401 📞 www.DeWittAmericasCupArt.com

Wednesday-Saturday 11:00-6:00 📞 Sunday 11:00-5:00

2013 Northern California SAILING CALENDAR AND YRA MASTER SCHEDULE



Pick it up with your January issue of
Latitude 38

Follow the action in 'Lectronic Latitude at www.latitude38.com

ARE SLIP FEES KILLING YOU?

SAVE!

- Secure Land Storage
- DIY Work Yard

NOW OFFERING A MOVE-IN SPECIAL

With a one-year storage contract, we will amortize the cost of haul-out and transport over the course of one year.

- 24-HOUR SECURITY •

Call for rates or reservations

(800) 660-8132

www.sandiegoboatmovers.com



6996-A Mission George Rd.
San Diego, CA 92120

205 Cutting Blvd.
Richmond, CA 94804

START SAVING TODAY!

MAX EBB

The problem is as old as the first anchor: How to get ashore from your anchored boat. The answer is and always has been obvious: Bring a dinghy. And from there, the solutions diverge.

On Long Island Sound, everyone tows their dink. For crossing open water, ocean cruisers carry inflatables. Megayachts have helicopters. But this was just an afternoon raft-up at Angel Island, and none of those solutions were practical.

This wouldn't have been a problem just a few years ago, when big raft-ups were allowed at the Angel Island mooring balls. But now they limit the number of boats on any one set of mooring buoys, so our group was distributed around the cove. I was tied up alongside one other boat that was similarly deficient in shore transportation.

The event was the Holiday Orphans' Cruise, organized each year by some of the berthers in my marina. All the liveboards and other wayward sailors with no close relatives in town have a huge raft-up and potluck feast over in Ayala Cove. Unfortunately, not being an orphan, I always have to miss it. But this year, with the rest of the family engaged elsewhere that day, I pretended to be an orphan to join the fun.

"Well, I guess you could drag out your big inflatable," I suggested to the skipper of the boat alongside. He was a longtime liveboarder, and I knew he had a nice inflatable dinghy that worked with the outboard clamped to his stern pulpit.

"That thing is such a pain to set up," he complained. "And it has a slow leak.

I'll call the mothership on 16 again."

No one answered on 16, probably because the party was already well underway on the big boat that served as party central for the fleet. And their radio, if it was even on, was not getting anyone's attention. But I did notice a small kayak heading in our direction, and as it drew closer I recognized the paddler.

"Lee!" I shouted. "You're not an orphan — don't you always go home for the holidays?"

"Not this year, Max," she answered as she coasted alongside in a smartly-executed skidding turn. "I'm, like, the only one left on my floor of the dorm, so it's a good time to work on my thesis, and also go sailing."

"You mean you're finally going to finish your degree?" I said in amazement.

"If we get a lot of rain this winter," she predicted. "And not too much wind."

Clearly she still prioritized windsurfing above scholarship, so I concluded that I did not have to worry about my best crew being lost to a full-time job.

"Did you paddle that thing all the way across from the marina?" I asked.

"No way!" she replied. "It's a folder. Takes just five minutes to assemble."

"I had one of them folding boats once," added the skipper on the boat I was tied to. "Always leaked through the seams, and was too flexible for a motor of any size."

"Check out this one," Lee replied. "It's a totally new generation of folding boat, and the only seam is along the deck centerline. Everything else is a fold, like an origami puzzle, and it's got little bulkhead

and gusset pieces that snap in so it's very stiff when everything is tensioned up. It's so cool the way it folds into itself, and even the paddle fits inside the package."

"That's all well and good," said my friend from the other boat, "but next time bring the three-person version so you can ferry us over to the party."

"They might make a double in the future," Lee

explained, "But this is just a prototype for the single. Not sold in any store, at least not yet. But I'll paddle back to the raft-up and send a dinghy your way."

She sped off across the anchorage with a few easy strokes of the double paddle.

Surely someone in the raft-up must have brought a real dinghy with an outboard, but when help arrived it was Lee Helm again, this time in an inflatable open kayak.

"You called for a taxi?" she hailed as the yellow inflatable boat bounced alongside.

"Uh, we asked for a water taxi, not a



Max and Lee's Holiday Gift Guide

Oru Kayak

www.orukayak.com

Around \$800 and not available until spring. Invented by Anton Willis, it's the best folding one-person boat. The seat and paddle fit inside the package, and it assembles in just five minutes.



Sevylor Tahiti Kayak

www.sevylor.com/Tahiti-Classical-Kayak-P1813.aspx

More economical at \$175. The tried and true 'pool toy' of shore boats, but it's perfect as a small sailboat's short-range tender, as long as the rocks aren't too sharp.



Quickboats

www.quickboats.com

Not yet available, this looks like a good implementation of a folding powerboat, even with a price tag of \$3,000. Without being able to test, it's impossible to tell if it's any good, but the goofy promo video at their site is worth a watch.





Lee Helm demonstrates an Oru Kayak. The only seam is along the deck centerline.

MAX EBB

pool toy," complained my friend.

I climbed in carrying my contribution to the potluck, but my friend was skeptical.

"We'll be well below the Plimsoll mark," acknowledged Lee, "but I think the International Maritime Organization will grant us an exemption considering the route and the sea conditions."

After a little more hesitation he passed down a case of beer to contribute to the party, and then lowered himself carefully into the middle of dinghy. With just an inch of freeboard at our sagging midships, Lee carefully paddled us over to the mothership.

"Not nearly as nice a ride as the Oru Kayak," she observed, but sometimes a

pool toy is, like, all you need."

After setting out my tray of sushi and sampling some of the other offerings, I asked Lee if I could take the Oru Kayak out for a spin.

"Sure, but don't flip. I didn't put the flotation bags in it."

There's almost nothing as much fun as paddling a light and slippery single kayak around a calm anchorage full of your friends' boats. And according to Lee, this thing would fit in my cockpit locker.

"I'm writing to Santa Claus," I said to Lee as I climbed out of the kayak after my loop around the cove.

"They're taking orders," said Lee, "But the builder says they won't be in production till spring."

"Which reminds me," I said, "I've got a shopping list to fill out for the holidays. Any ideas for interesting new gifts and gadgets this year?"

Lee could see right through this ploy. Whenever I ask her for suggestions for gifts for other people, she rightly guesses that I'm really fishing for a gift idea for her. But she plays along.

"It's the end of a year that's divisible by four," she said, "and you know what that means."

"Leap year? Olympics?" I guessed. "Presidential election?"

"No, none of those are important," explained Lee. "It's the year for a new version of the racing rules. And that means a new rulebook, a new version of the USS appeals and the ISAF cases, and new smartphone apps for quick look-ups."

Rule Book

store.ussailing.org/browse.cfm/racing-rules-13-16/4,728.html

ISAF Racing Rules of Sailing, as adopted by US Sailing. This is especially appropriate for the skipper of another boat with which you might have had an 'interaction' over the course of the previous season. \$30 from US Sailing, \$15 if

you're a member.

Or get the smartphone app instead for just \$6. Especially handy for looking things up quickly. And it's allowed in the exam room for the USS Judges certification!

US Sailing sells a protest flag too, but at 8" square it's too small to be legal for YRA. Nice big ones are easy to find; search your favorite online retailer for 'code flag B'.

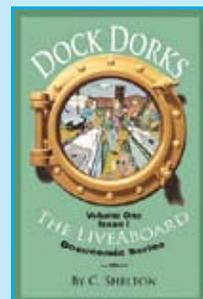

Dock Dorks

www.cynxing.com

A painfully honest must-read for any liveaboard. The first in a series of liveaboard cartoons is just \$12 plus shipping. Order direct from C. Shell at the link above.

Kannad Marine Personal AIS Emergency Beacon

www.kannadmarine.com

The SafeLink R10 SRS is latest in personal overboard safety. It attaches to a PFD and is manually activated. It offers an immediate precise target on all AIS receivers within a four-mile radius, providing the exact location, range and bearing of the MOB. The long-life battery will transmit nonstop for at least 24 hours. Features a flashing LED light for nighttime rescues. A bargain at \$300.



MAX EBB

bor, most of them liveaboards. Lee must have recognized some of them, too.

"Trawler trash," she whispered.

"Lee," I said. "Some of those guys are my friends."

"I totally mean it in a good way," she backpedaled.

Packages were passed up to the party boat — about equal tonnage of food and booze — and they climbed aboard after. Clearly the party was about to gear up a notch, but before that happened someone recognized someone on a Newport 30 who needed a ride over to the raft-up.

"It's C. Shell!" he said as he hopped back into the dinghy. "I'll zip over and pick her up."

A minute later the high-powered dinghy was back with the passenger. Apparently most of this crowd knew her — they had once been liveaboard dock neighbors in a different marina.

"Anybody expecting anything good from Santa this year?" she asked as she climbed aboard the party boat.

C. Shell did not bring any food or drink to contribute, but instead had a bundle of what looked like little comic

books.

"I don't have any family in town," said one of her old friends.

"My ex confiscates all my mail," said another liveaboard.

"Who would think to give me a present?" complained another marina urchin.

"Here, guys, one for each of you," she said as she handed out the little pamphlets. "Happy holidays."

"Dock Dorks!" the first urchin exclaimed. "C, you did it! The book! Am I in here, like you promised?"

"I didn't promise nothin'," she insisted, but her old friends put down their drinks to comb the pages of this book of cartoons, mostly about the liveaboard culture and lifestyle, and mostly drawn from C. Shell's personal experience.

"Hey, guys," said one of them with a concerned tone. "We don't come off looking so good in some of these 'toons."

"Speak for yourself!" retorted another old dock neighbor of his. "She drew me as looking pretty good . . . oh wait . . .

never mind."

"This is just the first of four volumes," C. explained. "Eventually I'll publish the complete collected works in a square binding."

"Cool!" said Lee.

"I know a liveaboard who needs this book," said the owner of the big boat that was hosting the party, after flipping through one of the samples. "Do you have extras with you to sell?"

"Of course!" C. confirmed.

Meanwhile, the party animals on board were finding more drawings of themselves in not-always-flattering situations.

Truth is a defense in libel cases, and even the scurvy bunch of actual "dock dorks" depicted in the book recognized the truth in their characters. After another round of drinks they were all having a good laugh at most of the cartoons.

But I'll be thankful to get back to having holiday dinners with my actual relatives again.

— max ebb



SPECTRA
WATERMAKERS™

EFFICIENT. POWERFUL.
UNSURPASSED CUSTOMER SERVICE.

www.spectrawatermakers.com



ALPENGLOW
LIGHTS

PAS
www.practical-sailor.com
BEST CHOICE 2010

406.889.3586

Hand Crafted, High-Efficiency Area Light
LED Reading & Berth Lights – NEW Dimmable Model

- Better light quality; superior color rendition
- Lower battery drain!
- Variety of wood selections to match your interior
- Night-vision and Splashproof options available
- Choose LED or CFL (compact fluorescent)



Alpenglow Lights, LLC, P. O. Box 415, Eureka, MT 59917
www.alpenglowlights.com

Innovative marine products



Mastlift & Accessories
Safest way to the top of a mast, you are in total control of your ascent and descent, work with both hands free, use as hoist for the dinghy motor, safely transfer mobility-challenged persons aboard, use in MOB rescues.



Anchor Buoy
Self adjusting
Do you know where your anchor is? You would with the self-adjusting Anchor Buoy from SWI-TEC! Precisely marks the anchor's set position and keeps other boaters at a distance. Can be used to a maximum depth of 65 ft.

Contact SWI-TEC America for
• WASI Power Ball • PropProtector
• WinchRite • Räber Meteograph

SWI-TEC America
INNOVATIVE MARINE PRODUCTS
www.swi-tec.us

California Professional Divers Association
Is your hull cleaner a member? If not, he should be

CPDA members are the only divers in California trained and certified in the use of state-recognized In-water Hull Cleaning Best Management Practices. These BMPs are designed to minimize the diver's impact on the environment and maximize your expensive anti fouling paint's lifespan and performance.

Visit our web site to find a conscientious, professional hull cleaner near you.

www.prodivers.org
(619) 600-0444 info@prodivers.org



California Professional Divers Association
"Environmentally Conscious for the Health of Our Industry"

JUST YOU AND THE SEA...



...and the jacuzzi,
the 80-ft long pool, the surf,
the Punta Mita anchorage, and the 4-mile distant
Tres Marietas Islands

Punta Mita Beachfront Condos

Call Doña de Mallorca for reservations!

1.415.599.5012

www.puntamitabeachfrontcondos.com

ATLANTIC 57 CATAMARAN™



- THE ORIGINAL PILOTHOUSE CATAMARAN
- o Designed for easy shorthanded cruising
 - o Spectacular windward performance
 - o Cored epoxy/glass/carbon construction

CHRIS WHITE DESIGNS
TEL: 508-636-6111
www.chriswhitedesigns.com



MARINE BATTERIES



Available at the following local marine chandleries and service distributors:

- | | |
|---|---|
| ALAMEDA
The Boatyard at Grand Marina
Star Marine
Svendsen's Chandlery | MARTINEZ
Martinez Bait & Tackle |
| BENICIA
Cruising Seas Services | OAKLAND
Outboard Motor Shop |
| EMERYVILLE
Mathiesen Marine | OAKLEY
Big Break Marina |
| | RICHMOND
Swedish Marine
Bay Marine |

AMERICAN BATTERY • Hayward, CA • (510) 259-1150

WEDLOCK, RAMSAY & WHITING Marine Surveyors



Vessel surveys,
consulting, deliveries.

Serving the
Bay Area
since 1980



www.norcalmarinesurveyors.com
(415) 505-3494



- Solar panels
- Wind generators
- Hydro-generators
- Inverters/ battery chargers
- Mounting systems
- Meters and accessories



Authorized wind generator and inverter service center



Ft Lauderdale, FL

954-581-2505

www.eMarineSystems.com

THE RACING

For most of the country, November's weather is not known for being pleasant, but on San Francisco Bay, it was downright balmy. Sadly, there were only a handful of races to take advantage of mellow fall conditions. IYC's **Jack & Jill + 1**, RYC's **Great Pumpkin** and TYC's **Red Rock** regattas were three we covered, along with **RegattaPRO's Winter One Design** and **BYC's Midwinter** series. **Race Notes** will cover many of the rest.

Jack & Jill + 1

Island YC's *ménage à trois* for women skippers went off on November 4 in shorts weather and just enough of a northwesterly to start on time and keep the seven entries sailing properly. They ranged in size from a Santana 22 to a Tartan Ten. The Spinnaker fleet got a 5.6-mile double-sausage course. The Moore 24 *Snafu*, helmed by Angela Robbrock with husband Karl on foredeck and Mark Simpson trimming, kept the pressure on the theoretically faster Laser 28 *Stink Eye* all the way around the course and stretched out a lead on everyone else. *Stink Eye* finished a mere six seconds ahead with no hope of making up her time on *Snafu*. The Merit 25 *Faster Faster*, sailed by Deb Fehr, finished a couple of minutes later to earn second place. Dawn Chesney's J/24 *Dire Straits* rounded out the division.

The Non-Spinnaker boats got a quickie 2.8-mile single-sausage course. Pam Krawiec skippered the Tartan Ten *Ghost* to a convincing victory over Judith Maurier's Alerion 28 *Scrimshaw*, which placed second, and IYC Commodore Kristen Soetebier's Tuna *Pueo*.

But Soetebier won another honor, that of Queen of Latitude 38's Unofficial Women's Circuit, having skippered entries in Jack & Jill + 1 and Sadie Hawkins (IYC's full-crew women skippers' race in February), and volunteered her time at Island YC's Women's Sailing Seminar in September. Our congratulations to Kristen and to her female-friendly club!

— latitude / chris



The 'Snafu' crew won the Spinnaker Division and enjoyed their prizes: beer, chocolate and wine!

Red Rock Regatta

Nine boats turned out for Tiburon YC's annual Red Rock Regatta on November 3. This race used to be sailed on the Saturday before Halloween, but the

RYC Great Pumpkin Regatta, just across the Bay, has become the Halloween event and so a couple of years ago the Red Rock Regatta was moved to the Saturday after Halloween. The course features Red Rock Island with other marks added as the weather allows.

This year's fleet was split into two divisions that, after a 40-minute postponement waiting for the wind to arrive, sailed the short course from TYC to Red Rock and back in a light northerly breeze. In Division 1, Mariellen Stern's J/105 *Joyride* and this writer's C&C 29 *Siento el Viento* got good starts but soon ran out of wind. Richard Selmeier and his crew on his C&C 33 *Hurricane Gulch* looked for more wind farther south. As the wind backed to a northwesterly and filled in from the north, Gerry Gunn on his Hawkfarm *Red Hawk* got the advantage.

At Red Rock, *Joyride* was well in the lead with *Red Hawk*, *Hurricane Gulch* and *Siento el Viento* turning in that order. *Siento el Viento* hoisted the spinnaker quickly and, taking advantage of the flood tide, sailed a southerly course to the finish, while *Red Hawk* and *Hurricane Gulch* enjoyed a close-fought battle farther north. *Joyride* held on to her lead to finish first in the division on corrected time, though the more southerly course and a fading breeze proved to be advantageous to *Siento el Viento*, which crossed the finish line just in front of *Hurricane Gulch* to take second on corrected time.

In Division 2, it was Ann Watson on

her Cal 2-27 *Wind Dance* who had the good start and led from beginning to finish. Garth Copenhaver in the Santana 22 *Oreo* battled the legs to and from Red Rock with Don Kunstler in his Santana 28 *Don Wan* but lost out by overestimating the flood current. Meanwhile, farther



Kristen Soetebier, Queen of the Latitude 38 Women's Circuit.



back in the fleet, Gary Proctor sailing his C&C 30 *Meritime* singlehanded and Brian Forster on his Newport 30 *No Agenda* both found the light airs not to their liking.

— ian matthew

TYC RED ROCK REGATTA I (11/3)

DIVISION 1 — 1) **Joyride**, J/105, Mariellen Stern; 2) **Siento el Viento**, C&C 29, Ian Matthew; 3) **Hurricane Gulch**, C&C 33, Richard Selmeier; 4) **Red Hawk**, Hawkfarm, Gerry Gunn/John Sullivan. (4 boats)

DIVISION 2 — 1) **Wind Dance**, Cal 2-27, Ann Watson; 2) **Oreo**, Santana 22, Garth Copenhaver; 3) **Don Wan**, Santana 28, Don Kunstler; 4) **Meritime**, C&C 30, Gary Proctor; 5) **No Agenda**, Newport 30, Brian Forster. (5 boats)

Full results at www.tyc.org

RegattaPRO Winter One Design #1

Last month heralded the start of many Bay Area yacht clubs' midwinter series, and the RegattaPRO Winter One Design series' November 10 kick-off was sailed in typical midwinter style. Shifting winds frustrated racers and the race committee alike. "We set the mark and started the first four fleets — J/120s, J/105s, Melges 24s and Antrim 27s," says RegattaPRO head honcho Jeff Zarwell. "The wind shifted, so we dropped a second windward



WWW.NORCALSAILING.COM

The wind filled in just enough for race two during the RegattaPRO Winter One Design series.

mark for the J/24s. Oops, another shift! We shortened the course to let everyone finish at the leeward mark, and five minutes later, the doldrums set in."

Zarwell reports there was barely a breath of wind for the next hour and a half, but it finally picked up enough — from yet another direction — to allow the second race of the day to start and finish. "There were major shifts all the way up and down the course, leading everyone to believe the race was a crap shoot," he said. But as he noted, the results prove that a number of Bay Area sailors clearly know how to sail in the light stuff, promising a tight series.

— latitude / ladonna

REGATTAPRO WINTER ONE DESIGN #1 (11/10)

J/120 — 1) **Grace Dances**, Dick Swanson, 3;

2) **Desdemona**, John Wimer, 3. (2 boats)

J/105 — 1) **Godot**, Phillip Labey, 4; 2) **Alchemy**, Walter Sanford, 5; 3) **Jam Session**, Adam Spiegel, 5. (12 boats)

J/24 — 1) **Downtown Uproar**, Darren Cumming, 2; 2) **Frog Lips**, Richard Stockdale, 5; 3) **Snowjob**, Brian Goepfrich, 7. (6 boats)

MELGES 24 — 1) **Personal Puff**, Don Hauserman, 2; 2) **Wilco**, Doug Wilhelm, 4; 3) **Nothing Ventured**, Duane Yoslov, 6. (5 boats)

ANTRIM 27 — 1) **Always Friday**, John Liebenberg, 2; 2) **Arch Angel**, Bryce Griffith; 3) **Abacadabra**, Ian Chamberlain, 5. (3 boats)

Full results at www.regattapro.com

Great Pumpkin Regatta

Spring-like conditions blessed the Halloween fleet of Richmond YC's Great Pumpkin Regatta with sunny skies and 7- to 14-knot westerlies for three buoy races on Saturday, October 27. The race committee offered three sailing areas for the 143 starters on what were fairly short windward-leeward courses that put a premium on starts and boat handling.

The largest one design fleets were the Moore 24, Express 27 and Open 5.70 fleets with 11 entries each, with the Wyliecat 30s having 10 on the line. The competition was close in the Moore and Wyliecat fleets as seven boats scored in the top three in each division.

Recently crowned Moore 24 National champion Bart Hackworth sailed his Richmond-based ULDB *Gruntled* to just one point better than Bill Erkelens' Richmond-based *Eclipse*. Richmond's John Skinner and Steve Seal's Wyliecat *Silkye* paid a similar favor to Steve Woner's *Uno*. It's interesting to note that the Wyliecat fleet was so competitive that any one of six boats could have won mathematically as they started the third

and final race!

Out on the deep water course the close proximity of marks played havoc with the big boats. With less than a mile between marks, crews were physically pressed, and every mistake, big or small, cost position. At the end of the day, the six-boat PHRF S fleet finished with only a five-point spread. Daniel Thielman's R/P 44 *Tai Kuai* got what looked like a clean start in the third race and appeared set to pounce on the division, but failure to clear an OCS scuttled the hopes of the *Tai Kuai* crew. Instead, Mary Coleman's navy blue Farr 40 *Astra* — with Carlos Badel calling the shots aboard the SFYC entry — survived the cage fight and beat out John Clauser's 1D48 *Bodacious+* and Brad Copper's Tripp 43 *TNT*.

With high pressure building for Sunday's pursuit race and a forecast for no wind building to not much more, few held any hope of actually sailing. As the noon hour came and went, the people of the fleet, joined by a contingent of 17 multihulls, seemed happy to stick it out in the warm sunshine as chants of "Let's go, Giants!" occasionally rose from the boats.

Patience brought its reward and, at roughly 2:30 p.m., a band of stratus clouds appeared along the Cityfront and with it a familiar 15-knot westerly. The RC rolled the sequence off three hours late, and right off the bat VHF's crackled as a handful of skippers called in to withdraw. They probably figured they couldn't sail the 14-mile course in time to beat the 5 p.m. deadline. With an almost four-knot ebb running, it's hard to blame them.

Almost two hours later, with the counterclockwise "wrong way" boats pinned up behind Angel Island, a bevy of spinners filed along the edges of Raccoon

For more racing news, subscribe to 'Latitude' online at www.latitude38.com.

November's racing stories included: US Disabled Sailing Championships • GGYC Manuel Fagundes Seaweed Soup Regatta • SYC Midwinter Race • VYC Midwinter Race • SDYC Sir Thomas Lipton Cup • LaserPerformance/ICSA Singlehanded Nationals • ISSA Cressy Trophy • Kennedy Cup/ICSA Big Boat National Championship • Vendée Globe coverage (see *Sightings*) • US Sailing & ISAF news • Race Previews and much more!

THE RACING



Great Pumpkin fun — (Left page, clockwise from top) Saturday: Gordie Nash's 'Arcadia' took top honors in PHRF F; Parking Lot A; 'Daisy Cutter' was pretty in pink; the 'Kilo' crew wrassled with the spinnie; the 5.70 fleet looked great coming (center) and going; "I yams what I yams!". (Right page, clockwise from bottom right) Sunday: 'Another Girl' followed 'GravlaX' to the line; finally taking 'Flight'; Kame Richards had adorable crew on 'Golden Moon'; the haunted boat, 'Jack Aubrey'; the multihulls caught up in the end; (center) 'Wild Rumpus!' got wild; this crewmember sassed the skipper. Boo!

Strait, with Gordie Nash's yellow *Arcadia* in the lead and untouchable among his PHRF brethren. Seeming to not want a Santana 27 — even a highly modified one — to take line honors, the multihulls pushed hard to catch up. Eric Willis's Nacra F20 *Curved Wood*, Rodger Barnett's F40 *Tuki*, and Peter Stoneberg's M&M Prosail 40 *Shadow* all managed to overtake Nash's team just yards from the finish.

And as the deadline to finish expired, with the ebb now at max and the breeze dying, dozens of boats were left to practice rules of the road in close proximity all while going nowhere. Of the 189 starters, only 36 finished.

— dave wilhite

RYC GREAT PUMPKIN REGATTA (10/27)

DEEP WATER COURSE (3 races):

PHRF S — 1) **Astra**, Farr 40, Mary Coleman; 2) **Bodacious+**, 1D48, John Clauser; 3) **TNT**, Tripp 43, Brad Copper. (6 boats)

PHRF U — 1) **Twisted**, Farr 40, Michael Pohl; 2) **Wicked**, Farr 36, Richard Courcier; 3) **Tiburón**, Santa Cruz 37, Steve Stroub. (5 boats)

PHRF V — 1) **Encore**, Sydney 36, Wayne Koide; 2) **Raven**, Beneteau First 35, David Schumann; 3) **Jeanette**, Frers 40, Henry King. (9 boats)

PHRF W — 1) **Eight Ball**, Farr 30, Scott Easom; 2) **Desdemona**, J/120, John Wimer; 3) **Intruder**, Melges 32, Greg Dyer. (9 boats)

EXPRESS 37 — 1) **Golden Moon**, Kame Richards; 2) **Stewball**, William Travis; 3) **Snowy Owl**, Jens Jensen. (3 boats)

J/105 — 1) **Godot**, Keith Laby; 2) **Javelin**, Charlie Abraham; 3) **Joyride**, William Hoehler. (5

boats)

MELGES 24 — 1) **Personal Puff**, Dan Hauserman; 2) **Wilco**, Douglas Wilhelm; 3) **Mako**, Stephen McMillan. (3 boats)

OLYMPIC CIRCLE COURSE (3 races):

PHRF F — 1) **Arcadia**, mod. Santana 27, Gordie Nash; 2) **Wild Rumpus!**, Santa Cruz 27, Stephanie Schwenk; 3) **Don Quixote**, Santa Cruz 27, Craig Smith. (4 boats)

PHRF Q — 1) **Lilith**, Wyliecat 39, Tim Knowles; 2) **Ahi**, Santana 35, Andy Newell; 3) **Sheeba**, C&C 99, Michael Quinn. (5 boats)

PHRF Z — 1) **Chaos**, Olson 30, Raymond Wilson; 2) **Sweet Okole**, Farr 36, Dean Treadway; 3) **Another Girl**, Alerion Express 38, Cinde Lou Delmas. (5 boats)

ISLANDER 36 — 1) **Luna Sea**, Dan Knox; 2)



ALL PHOTOS ERIK SIMONSON / WWW.PRESSURE-DROP.US UNLESS NOTED

Vivace, Bill & Pattie O'Connor; 3) **Califia**, Tim Bussiek. (3 boats)
 SF 30 — 1) **Shameless**, George Ellison; 2) **Bay Loon**, Grant Harless; 3) **Heart of Gold**, Joan Byrne. (6 boats)
 WABBIT — 1) **Mr. McGregor**, Kim Desenberg; 2) **Wild Bunch II**, Aaron Sturm; 3) **Bad Hare Day**, Erik Menzel. (5 boats)
 EXPRESS 27 — 1) **Wile E Coyote**, Dan Pruzan; 2) **El Raton**, Ray Lotto; 3) **Dianne**, Steve Katzman. (12 boats)
 WYLIECAT 30 — 1) **Silkye**, John Skinner/ Steve Seal; 2) **Uno**, Steve Winner; 3) **Dazzler**, Tom Patterson. (10 boats)

SOUTHAMPTON COURSE (3 races):
 OLSON 25 — 1) **Shadowfax**, Mark Simpson; 2) **Balein**, Daniel Coleman; 3) **Shark on Bluegrass**, Falk Meissner. (6 boats)
 CAL 20 — 1) **Can O'Whoopass**, Richard vonEhrenkrook; 2) **Recluse**, Howard Martin; 3) **Invader**, Byron Jonk. (3 boats)

J/24 — 1) **Downtown Uproar**, Darren Cumming; 2) **Shut Up and Drive**, Val Lulevich; 3) **Flight**, Randall Rasicot. (4 boats)
 MOORE 24 — 1) **Gruntled**, Bart Hackworth; 2) **Eclipse**, William Erkelens; 3) **Blue in Green**, Gilles Combrisson. (11 boats)
 OPEN 5.70 — 1) **The Maker**, Tom Baffico; 2) **Boracic**, Michael Gough; 3) **Revenge from Mars**, Dave Peckham. (11 boats)
 SANTANA 22 — 1) **Oreo**, Garth Copenhaver; 2) **Carlos**, Jan Grygier; 3) **Byte Size**, Anna Alderkamp. (5 boats)
 ULTIMATE 20 — 1) **Layla**, Tom Burden; 2) **Ugain**, Dave Woodside; 3) **Viola**, Stephen Leonard. (7 boats)
 PHRF G — 1) **Hog Wild**, Santana 20, John Spillman; 2) **Critical Mass**, Mancebo 24, Dodds Syndicate; 3) **Road Runner**, Ranger 23, Gregory Demetrulias. (7 boats)

RYC GREAT PUMPKIN REGATTA PURSUIT RACE (10/28)
 PHRF — 1) **Arcadia**, mod. Santana 27, Gordie Nash; 2) **Moorigami**, Moore 24, John Siegel; 3)

Flying Tiger, Moore 24, Vaughn Seifers. (172 boats)
 MULTIHULLS — 1) **Curved Wood**, Nacra F20, Eric Willis; 2) **Tuki**, F40, Roger Barnett; 3) **Shadow**, Prosail 40, Peter Stoneberg. (17 boats)

Full results at www.richmondyc.org

Berkeley YC Midwinter Series
 On the same weekend that RegattaPRO's racers bobbed around to the west of the Circle, Berkeley YC kicked off their popular Midwinter Series in the center of the Circle (November 10-11). They also observed the wind reversing directions. "After only 1 hour and 45 minutes of chasing cat's paws," wrote Race Chair Bobbi Tosse, "we elected to start the 56 mostly patient yachts on a short four-mile race." At the time of the first start, the wind appeared to be coming from the east. "As the start sequence for the nine divisions rolled on, the wind

THE RACING

direction also rolled on, clocking right as it proceeded. We can say with certainty that the wind direction on Saturday was 'variable.' They ended up with a south-southwesterly, and all 56 boats were able to finish, many under spinnaker.

"On Sunday, the ripples on the water were from real (but very light) wind," continued Tosse. "The 24 entries enjoyed an on-time start, and an eight-mile course." One of the racers that day told us she even saw whitecaps.

— latitude / chris

BERKELEY YC MIDWINTER SERIES SATURDAY

DIVISION A — 1) **Relentless**, Sydney 32, Arnold Zippel, 1; 2) **Family Hour-TNG**, Henderson 30, Bilafer Family, 2; 3) **GravlaX**, X102, Gael Simon, 3. (7 boats)

DIVISION B — 1) **Flight Risk**, Thompson 650, Ben Landon, 1; 2) **Baleineau**, Olson 34, Charlie Brochard, 2; 3) **Heart of Gold**, Olson 911S, Joan Byrne, 3. (4 boats)

DIVISION C — 1) **Phantom**, J/24, John Guliford, 1; 2) **American Standard**, Olson 25, Bob Gunion, 2; 3) **Prime Mover**, J/30, Lloyd Burns, 3. (4 boats)

DIVISION D — 1) **Oreo**, Santana 22, Garth Copenhaver, 1; 2) **Achates**, Newport 30, Robert



WWW.NOFCALSAILING.COM

The Berkeley Midwinters offered this crewmember a perfect opportunity to catch some shuteye.

Schock, 2; 3) **Crazy Horse**, Ranger 23, Nicholas Ancel, 3. (6 boats)

DIVISION E — 1) **Tiare**, Catalina 22, Paul McLaughlin, 1; 2) **Kodiak**, Bear, Peter Miller, 2; 3) **Huck Finn**, Bear, Margie Siegal, 3. (3 boats)

OLSON 30 — 1) **Hoot**, Andrew Macfie, 1; 2) **Chaos**, Ray & Craig Wilson, 2; 3) **Yankee Air Pirate**, Donald Newman, 3. (4 boats)

EXPRESS 27 — 1) **Motorcycle Irene**, Zachary Anderson, 1; 2) **Great White**, Rachel Fogel, 2; 3) **Abigail Morgan**, Ron Kell, 3. (12 boats)

MOORE 24 — 1) **Banditos**, John Kernot, 1; 2) **Twoirrational**, Anthony Chargin, 2; 3) **Mooretician**, Roe Patterson, 3. (8 boats)

CAL 20 — 1) **Fjording**, Tina Lundh, 1; 2) **Can O' Whoopass**, Richard vonEhrenkrook, 2; 3) **Recluse**, Howard Martin, 3. (4 boats)

BERKELEY YC MIDWINTER SERIES SUNDAY

DIVISION 1 — 1) **Ragtime**, J/90, Tryg Lijestrand, 1; 2) **Stewball**, Express 37, 2; 3) **Warp Speed**, C&C 115, Jeff Smith, 3. (5 boats)

DIVISION 2 — 1) **Banditos**, 1; 2) **Froglips**, J/24, Richard Stockdale, 2; 3) **Twoirrational**, 3. (5 boats)

DIVISION 3 — 1) **No Cat Hare**, Catalina 22, Donald Hare, 1; 2) **Antares**, Islander 30-2, Larry Telford, 2; 3) **Latin Lass**, Catalina 27, Bill Chapman, 3. (6 boats)

OLSON 30 — 1) **Hoot**, 1; 2) **Chaos**, 2; 3) **Yankee Air Pirate**, 3. (4 boats)

EXPRESS 27 — 1) **Motorcycle Irene**, 1; 2) **Libra**, Marcia Schnapp, 2; 3) **Dianne**, Steven Katzman, 3. (3 boats)

Full results at www.berkeleyyc.org

THE MARINE GRADE MOLD & ODOR ELIMINATOR

"My Cabin Smells Great!"

"I have a 43 footer with an odor that no amount of cleaning would eliminate. We placed Tea Tree Power Gel in the cabin and now the whole boat has a fresh scent. I'm a believer." - Greg C. South Wharf Yacht Yard

After only three days, my locker smells fresh and the mold that was present wipes clean very easily. Good stuff." - Rob M. Basin Marine

Marine Grade Odor Control

All Natural Made With 100% Australian Tea Tree Oil
 Degrades & Attacks Mold, Mildew, And Bacteria
 Neutralizes & Eliminates Odors Safely & Naturally
 Long Lasting-Protection Maintains Healthy Cabin Air

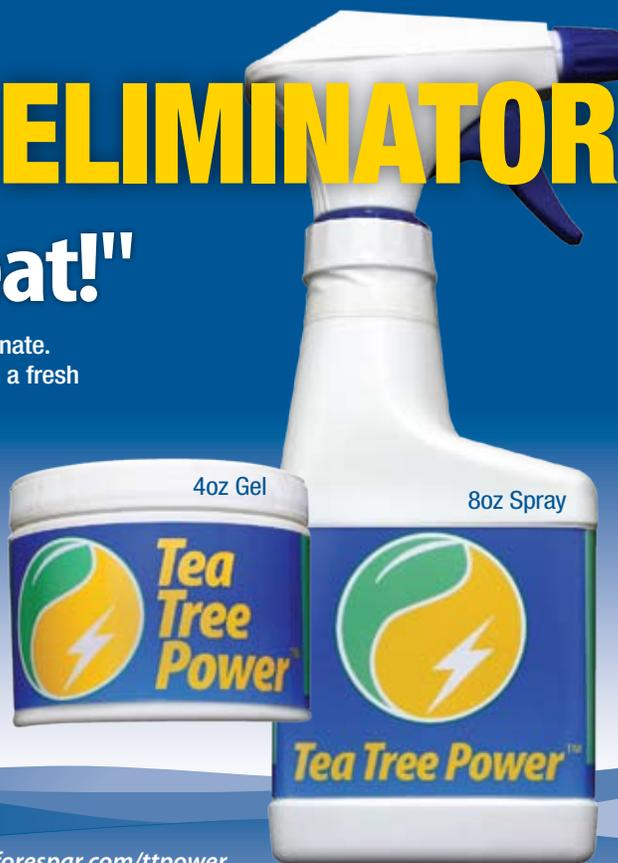

FORESPAR®

Tel: 949 858-8820 • www.foresparr.com/ttpower

Race Notes

December may seem early to start signing up for spring regattas, but not when the regatta in question involves traveling to the Caribbean. Entry is open for the **BVI Spring Regatta** and its three-day prequel Sailing Festival. Mark your 2013 calendar for March 25-31. See www.bvispringregatta.org.

Alamitos Bay YC of Long Beach holds their biggest regatta on the weekend before Thanksgiving, with turkeys for prizes. This year's **Turkey Day Regatta** boasted 18 classes, nearly 200 boats, and 300 competitors racing on two ocean courses and inside the bay. The homeports of winning skippers were spread from San Francisco Bay to San Diego. Among the results you'll find online at www.abyc.org, David West and Mark Roberts of RYC won the Mercury class, and Cooper Weitz of StFYC and SFYC topped the Laser Radial fleet. Brothers Dane, 17, and Quinn Wilson, 15, of Ojai and the Santa Barbara YC dominated the 29ers to win the 29er PCC Series. They have their sights set on moving up to 49ers and making it to the Rio Olympics. Speaking of which . . .

Did you just sell your wind-surfing gear at bargain base-ment prices and order a shiny new kiteboard at top dollar? Oops, sorry. ISAF has decided that RS:X windsurfers will be the boards of choice at the **2016 Olympic Games** in Rio de Janeiro after all.

The 27 entries in EYC's first **Jack Frost** on November 17 enjoyed 10-18 knot breezes and sun after an early morning rain shower passed through, reports Margaret Fago. In Division A, *Twisted*, Tony Pohl's Farr 40, pulled ahead by more than a leg to win both races of the day. His nearest competitor, *Red Cloud's* skipper Don Ahern, said, "They just did everything right. *Twisted* was flying, even when the winds picked up in the second race." See www.encinal.org.

The **sf2sf Ocean Race** course has been announced: Start in San Francisco in the fall of 2015, take Cape Horn to port, South Georgia Island to starboard, Cape of Good Hope to port, Kerguelen



RICH ROBERTS

Phil Toth and Dustin Durant saved their Viper from flipping on day 2 of Alamitos Bay YC's Turkey Day Regatta, held the weekend before Thanksgiving.

Island to starboard and Cape Leeuwin to port, and finish in San Francisco. "Run what you brung" is the philosophy for the first around-the-world race starting and ending on the West Coast of the U.S. Getting sponsors onboard is the current challenge. For more about this ambitious event, see www.sf2sfocceanrace.com.

SeqYC's **Hannig Cup** raised over \$43,000 to support youth sailing, Sea Scouts and the Marine Science Institute. PYSF's high school racing team, sailing the *J/29 L20*, raised the most money in the pursuit race held on August 29.

— latitude / chris

**Start Line Strategies**

**Winning Legal Planning
for Sport Programs**

10 years America's Cup Experience

Sponsor & Venue Arrangements • Crew Contracts
Vessel Shipping Logistics • Charter Agreements

Ashley Tobin

(925) 324-3686 • amtobin2@gmail.com

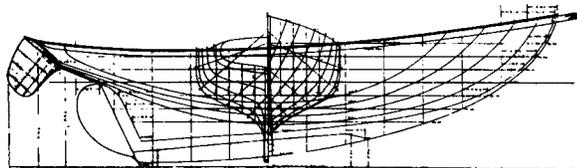
**MAKELA BOATWORKS**

Family owned since 1948

Wooden Boat Building • Repair and Restoration

19280 South Harbor Drive • Fort Bragg, CA 95437

(707) 964-3963

email: howard@makelaboatworks.com • www.Makelaboatworks.com

CYC 2013 MIDWINTER SERIES

★ ALL BOATS WELCOME ★

January 19-20 & February 16-17

One Design Starts for 5 or more entries!

Post-Race Festivities – Dinner & Dancing

Sign up soon and get your boat name on the T-shirt!

**Our 62nd
Annual
Midwinters!**

**Corinthian Yacht Club**

OF SAN FRANCISCO

43 MAIN, TIBURON, CA 94920 • **(415) 435-4771**

Sign up on our website: www.cyc.org

WORLD

With a report this month on **How to Choose a Vacation Sailing Venue**, plus miscellaneous Charter Notes.

A New Year Brings New Possibilities — For Worldwide Chartering

If you're like us, whenever a new year approaches you tend to reflect on all the things you'd intended to do that didn't quite happen. You know, projects at work that you still haven't conquered, home improvements that still linger on your 'to do' list, and sailing vacations you experienced only in your dreams.

Well, the arrival of a new year is a time for new beginnings and new goals. So we suggest you rev up your imagination and start conjuring up some brand new vacation fantasies. But this time we hope you'll actually follow through on them. Trust us, you'll be glad you did.

If you're new to 'sail-it-yourself' bareboat chartering, you may not realize just how many well-established charter bases there are to choose from. As you can see by the map below, you can rent a late-model bareboat from a reputable firm in just about every prime sailing area on the planet. (Many of these regions offer luxury crewed yachts also.) But with all those choices, which place should you visit first? The answer to that question has a lot to do with the makeup of your group, and the activities and attractions that you're most keenly interested in pursuing.

We'll try to help you through the decision-making process here by approaching the options through several key questions that are often asked of professional charter brokers: Which are the best venues for first time charterers? Which offer the best sailing? Which

are best for kids? Which offer the most interesting cultural attractions ashore? And which are the most exotic?

Before we get into all that, though, let us clarify a few basics. If you've never chartered a bareboat before, you're probably wondering what skills you need to demonstrate, or documents you need to show, in order to rent a quarter-million-dollar sailing yacht. Actually, you'd be surprised how easy it is to qualify. Remember that all charter companies want your business, so they don't want to make requirements so tough that they scare prospective clients away.

First, if you now own, or have previously owned, your own boat you'll easily be able to rent a boat of similar size or a bit bigger without a hassle. If you regularly crew on a decent-sized boat, and have a respectable sailing/racing resume, that will probably qualify you also. And while it's nice to show a competency certificate from a sailing school, such documents are *not* normally required.

If you want to rent a catamaran, but have little or no cat experience, that's generally not a problem either. Again, if you own or have experience on a 38-ft monohull, you'll probably be allowed to rent a similar-sized multihull.

Our advice is not to BS the sales staff. If you arrive at the boat and are obviously out of your depth, the check-out staff will definitely notice — and that could be embarrassing. If your resume's weak and your confidence is a little shaky, the better tactic is to request a captain for the first day or two. Within that time

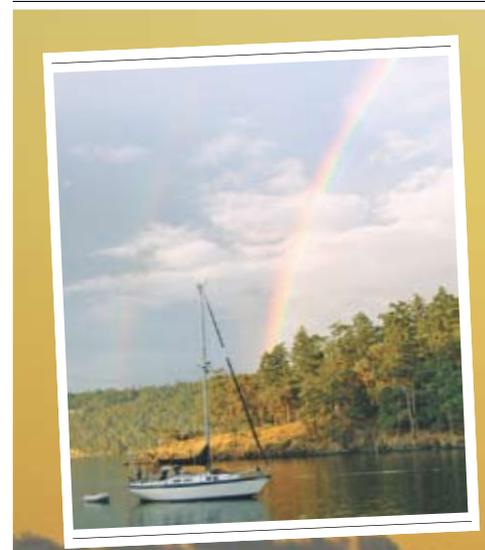

ALL PHOTOS LATITUDE / ANDY



most half-way-competent sailors can become comfortable with handling the boat and managing its systems. The bonus in this scenario is that you'll probably come away with some valuable local knowledge — things like where the best snorkeling spots are, where you can find a secluded anchorage, and which beach bar makes the best Planter's Punch.

Having gone over the basics, let's try to whittle down the venue options:



OF CHARTERING

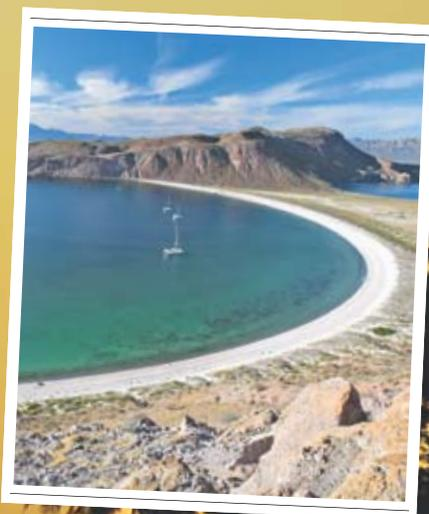

What destination is at the top of your chartering wish list? Spread: Tahiti? Inset, left to right: the San Juan Islands, (French) Guadeloupe, and Mexico's Sea of Cortez.

Best First-Timer Destinations —

You've probably heard a thousand times that the British Virgin Islands are at the top of our list for first-time charterers. And for good reason. Not only are BVI waters well protected, the distances between anchorages short, and the shore-side facilities abundant, but there are overnight mooring buoys in almost every popular anchorage. You can literally explore for two weeks without having to anchor — which is the most feared maneuver for most marina-based sailors.

Although we never tire of sailing in the BVI, that British Overseas Territory isn't the only place we'd recommend to first-time charterers. Roughly 350 miles to the southeast lies a cluster of tiny islands called the Grenadines. Here too, distances between islands and anchorages are quite short, and the sea state is generally pretty flat. But there isn't nearly the number of boaters, and not nearly as much development ashore as in the Virgins. Yes, you will have to anchor,

but with white sand beneath you in every anchorage, it's as close to a no-brainer as you'll find anywhere. Besides, you've gotta learn to set the hook sometime.

Another excellent first-timer destination is the greater Puget Sound region. Whether you choose to sail in the American San Juans or the Canadian Gulf Islands, you'll find benign conditions 90% of the time; excellent shoreside facilities, including many marinas; and breathtaking panoramas. You do have to pay careful attention to tides and currents, but that's a minor challenge that we've always viewed as part of the fun.

Best Sailing Winds —

Which venues offer the best sailing? We'd be fools to guarantee that you'll find ideal wind and weather anywhere in any given week. That said, though, the trade winds of the Eastern Caribbean are about

as predictable as you'll find anywhere. That's why Antigua Sailing Week and the Heineken Regatta are two of the most popular regattas in the world. From the Virgin Islands south to the Grenadines you'll typically find ideal 12- to 25-knot conditions year-round, interrupted only by passing storms and 'tropical waves' during the June-to-November hurricane season.

Where else? You can usually count on some pretty fine sailing conditions in New Zealand during their summers (our winters), as well as in the Tahitian islands, which promise tranquil lagoon anchorages combined with often-booming interisland passages. Wind strengths in Mexico's Sea of Cortez tend to cycle every few days, giving sailors everything from very light air to strong blows. Taken as a whole, though, there's generally plenty of nice breeze there in fall, winter and spring.

Best Venues for Kids — In our experience, the most fun young kids typically have on a charter vacation is when they're snorkeling. Find a set of mask, snorkel and fins that fit your kid, let him or her splash around for a few hours in clear water over an abundant reef, and you'll have one happy kid — one who won't give you a hard time at bedtime.

Older teens and young adults tend to like the autonomy of taking off on a sailing dinghy, windsurfer or kayak (translation: escaping their parental units). With these criteria in mind, there are a lot of places that will fill the bill: the Eastern Caribbean, Belize, the Sea of Cortez, Tonga, Tahiti, Thailand, the Whitsundays, the Seychelles, and even Florida. If your charter operator doesn't

For first-time chartering, the well-protected waters of the British Virgin Islands are hard to beat. But they are not the only viable option.





Got any serious history buffs in your group? If so, consider a trip to Turkey's ancient Turquoise Coast. Pictured here is Bodrum Castle.

offer watersports toys, you can often rent them from nearby waterside resorts.

Best Cultural Attractions — Which venues offer the most interesting cultural attractions ashore? Here we enter

a whole new realm of consideration. If some of your potential shipmates aren't diehard sailors, but love history, or simply like being surrounded by lively cultural traditions, there is a variety of destinations where such interests will be nourished while ashore, in addition to fine cruising under sail. Of course, anywhere in Europe is worth considering

— Brittany, Scotland, the French Riviera, Italy's western coastline, Croatia... But for serious history buffs, accessing the antiquities of the Greek Isles and Turkey's Turquoise Coast is tough to beat. Closer to home, the backwaters of Downeast Maine and the Chesapeake could also be considered, as towns there date back to colonial times. And when it comes to getting in touch with genuine Polynesian culture, both Tonga and Tahiti are sure to please.

Most Exotic Venues — Which venues are the most exotic? By our definition of the word, Thailand and Malaysia would definitely have to be high on the list, as would the dreamy isles of Tahiti and the Seychelles.

Yeah, we know: There are so many choices, yet so little time. If, after reading all this, you're more perplexed than ever about which venue to choose, why not gather a group of willing charter partners, introduce them to the options, and let them decide?

— *latitude/andy*

Are "Californians Dreaming?"

Stop dreaming – go sailing.

**CALL TO RESERVE AT OUR
BEST IN THE BVI PRICES!**



**Conch
Charters**

www.conchcharters.com

(800) 521-8939



Real People. Real Sailing. Real Fun.

Sail Cats | Power Cats
Monohulls | Trawlers
Bareboat | Skippered

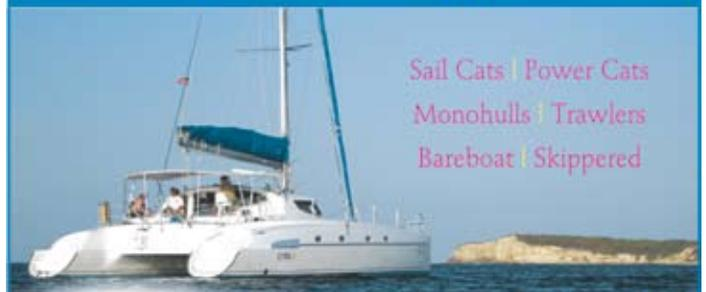

Real Choices.

Choose CYOA and become part of the family. We've been providing beautifully maintained yachts, personal service and sensible prices to sailors since 1980.



1-800-944-2962
info@cyoacharters.com
www.cyoacharters.com
St. Thomas USVI 00802



OF CHARTERING

Charter Notes

We've been told by tourism professionals that **California sailors** comprise one of the largest segments of the **Eastern Caribbean's tourism market** — and that's especially true in the U.S. and British Virgin Islands. As dependent as the BVI is on tourism, however, they've never built a jumbo-jet airport, so visitors have to route through the larger airports at St. Thomas, USVI, or San Juan, Puerto Rico. We've written before that if you can't get a direct flight from a U.S. gateway all the way to Tortola, BVI, a viable option is to fly into St. Thomas and take the hour-long ferry ride to Tortola. (Ferries don't travel at night, so plan accordingly: www.bviwelcome.com.)

Now there's an additional new option: **Southwest Airlines** has announced they will begin service to San Juan in April. While there are already plenty of U.S. carriers that go there, Southwest offers free checked baggage and flexible 'per leg' pricing. If nothing else, it's nice to have an additional option.

Ever dreamed about crossing the

Panama Canal on a sailboat?

Hopefully you'll have a chance to make that trip on your own boat someday. But in the meantime, be aware that the spectacular, Bay-based **schooner Eros** will be available this winter (**mid-December through April**) for special Canal transit charters, as well as cruises to the **San Blas and Las Perlas Islands**. (10 days to two weeks recommended.)

This meticulously refurbished 103-footer — see our October, '09 feature — takes up to eight guests in pampered comfort, and features gourmet cuisine. With her elegant lines and fine sailing



TOM BRICHTA

Having emerged from an 18-year refit in better shape than ever, the lovely schooner 'Eros' is a beauty to behold, and a pleasure to sail.

ability, she turns heads in every anchorage she enters. *Eros* is expected to be back in the Bay by summer. (For info, call 510-232-4282, email bodle.grace@gmail.com or see www.schoonererros.com.)



Tortola BVI
Belize
The Grenadines

UNIQUELY
TMM



Marisa
TMM Belize

Most charter companies offer blue water & palm trees, but it takes the personalized care of people like Marisa to make your vacation a success.

Like Marisa, everyone at TMM is committed to your complete satisfaction. Our specialized three-location operation offers large company quality with small company service. A combination that is uniquely TMM.



1.800.633.0155
www.sailtmm.com

catamarans • monohulls
motor yachts
ownership programs



10% Off
BAREBOAT CHARTERS

 **BVI YACHT CHARTERS**
Call: +1 888 615 4006
Or: +1 284 494 4289

BVI Yacht Charters is the first port of call for all yacht charters in the BVI and St Martin. Whether you are looking for a Catamaran or a Monohull, a week or just a few days, our professional team is on hand to make it work, your way.

BVI YACHT CHARTERS
** 10% off all new bookings when you mention this ad.
www.bviyc.com
charters@bviyc.com

CHANGES

With reports this month on **Liz Clark's** body-surfing accident; on **Migration's** passage from Fiji to Thailand to get boat work done; on **Second Chance's** loving the cruising life in Maine; on **Panache** and the longest four minutes in Zach Lough's life; on **Angel Louise** making preparations to cross Europe's Continental Divide by water; and **Cruise Notes**.

Swell — Cal 40

Liz Clark

A Dangerous Pain in the Neck (Santa Barbara)

Imagine an Olympic downhill ski racer falling down and breaking a leg on a bunny hill. That's probably how Liz Clark of the Santa Barbara-based Cal 40 *Swell*, who has been cruising French Polynesia for years, feels right now. As many *Latitude* readers know, she was a champion surfer while attending UCSB, and has surfed some of the most dangerous tubes in French Polynesia. Yet it was while body surfing in small surf off San Diego's Torrey Pines Beach last month that she badly injured herself.



Liz, not where she'd really like to be.

"The tide was dropping, and one particular sandbar beckoned," says Liz, setting the scene. "With half an hour to kill and a bladder full of tea, a swim seemed in order. So without another thought, I zipped up my Patagonia R1 spring suit and hopped down the rocks, one fin in hand. I limped across the short strip of sand and collapsed knee deep into my beloved ocean. Ahhhh!

"My second wave looked like a beauty. It approached from the north and stood up as I kicked into it. But as I plunged down the two-foot face, an odd warble cropped up, tossing me head over heels. Totally unexpectedly, my head hit the sand. My body was angled such that all

When a young woman with a broken neck can joke that she looks like Dog the Bounty Hunter, you know she's blessed with self-confidence.

its weight and the momentum fell upon the forward part of my head, snapping it backwards. "No way!" I thought to myself.

"I came to the surface and ran down the checklist. 'Okay. I'm conscious.' Check. 'I can move my arms and legs.' Check. 'I'm okay. I'm okay.'"

Liz wasn't really okay. Unable to get help because her cell phone was out of minutes, she drove herself the three miles to her sister's house, her neck feeling "unstable and weak," where she lay down in pain. She called a friend, an ER nurse, who rushed the health insurance-less Liz to Sharp Hospital.

The initial results from the CT scan showed no break, so Liz and her friend were ecstatic, and removed the neck brace. But then Dr. Healy, having double-checked the image, rushed into the room and stopped the celebration. "Secure that brace!" He'd found that Liz had indeed fractured her neck.

Liz has been taking the injury with gratitude that she didn't damage her spinal cord, and with positive thoughts and humor. Indeed, she's seemingly become obsessed with how ridiculous her hair looks from her having become a "ceiling inspector". When you can laugh at misfortune, you've got a lot going for you.

By the way, we've hoped to post Liz's favorite cruising recipes for the last two issues, but things have come up, so you'll just have to wait.

— *latitude/rs* 10/22/12

Migration — Cross 46 Tri Bruce Balan and Alene Rice Fast Track to Thailand (Long Beach)

While in New Zealand last May, we decided that *Migration's* 43-year-old polyester-resined fiberglass topsides needed to be replaced. We'd already done the bottom, wing decks, and deck, but now her topsides were starting to delaminate from the ply, demanding the same attention. Since Alene and I have spent months in various boatyards fiberglassing and sanding, we thought it would be nice to have someone else do the itchy work for a change. But where? New Zealand was too expensive, and

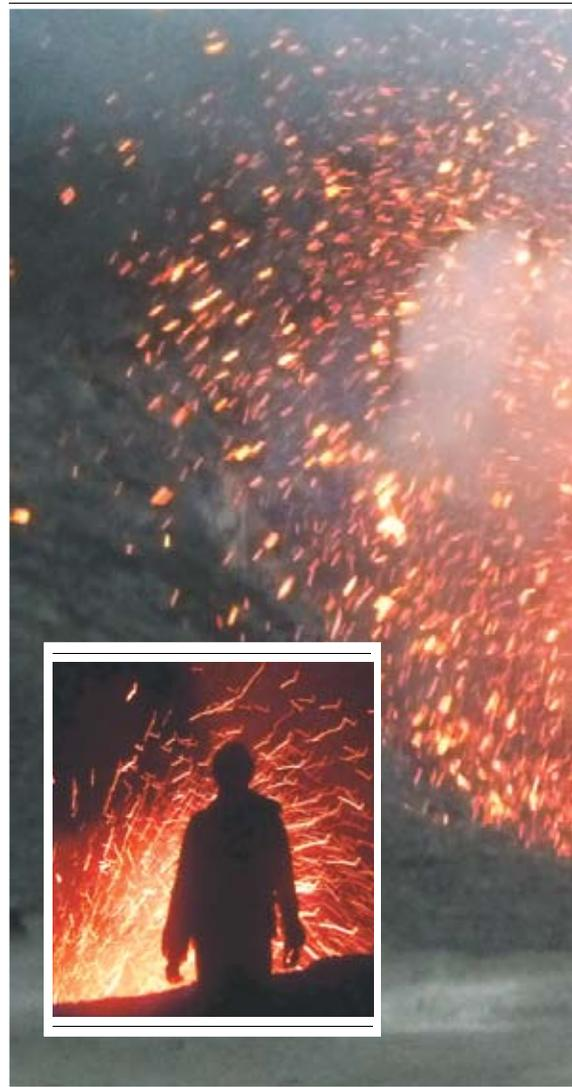

Oz even more so. Friends in Thailand told us of the good quality work they'd had done there, so after weeks of research, deliberation, and dithering, we made the decision to have the job done there.

But first we wanted to sail back to Fiji, as we knew it would be a long time before we returned to the Pacific. We had a great trip north from New Zealand, with long stops — and some great lobstering — at South and North Minerva Reef. Then we had two excellent months cruising eastern Fiji and the Lau Group of Fiji.

On August 4th we left Suva and turned west. We wanted to arrive in Thailand before the NE monsoon set in, so we had about three months to cover the distance. We calculated that we could do it by spending about 50% of the time underway.

Our first stop was Vanuatu, the highlight being Mt. Yasur, the fantastic volcano on Tanna Island. We hiked far



IN LATITUDES



PHOTOS COURTESY MIGRATION

There is 'living on the edge', which just about everybody claims to be doing, and then there is standing at the edge of the crater of Mt. Yasur while the Tanna Island volcano is erupting with molten lava. Bruce Balan can be excused for looking a little bug-eyed in the photo.

around the rim to where we could see the open pit blasting lava high above our heads. It was so exciting that our knees shook. While we were anchored in Port Resolution one night, the wind clocked around. We awoke to find *Migration* covered in ash. We were still finding ash in nooks and crannies months afterward.

Vanuatu deserves a whole season — if not three or four. But on our schedule we didn't have time to linger. After a stop in Port Vila to provision, we were off on a windy downwind run to North Indispensable Reef, which is part of the Solomon Islands. The open ocean reef is similar to Minerva, but far larger and much less visited. We stopped for only one night, enough time for a snorkel and to sit tight while a front passed through.

Three days of sailing brought us to the Louisiade Archipelago of Papua New Guinea. We've been hauling give-away stuff around the Pacific for years — including the original sails that came with *Migration* when I purchased her in '90, plus a whole set of old rigging — waiting to find someplace where the people could really use the stuff. Well, the Louisiades was the place! The people there need everything.

We had open trading days on *Migration*, with a constant stream of canoes from morning until night. We are firm believers in trading

rather than giving stuff away — except to schools and medical clinics — even if it's only for one yam. If the kids want a treat, we make them at least sing a song for us. We feel this keeps things on an even footing, with both parties respecting each other. We ended up with a lot of wonderful wood carvings and bagi shell necklaces. But our best deal was trading our sails and rigging for a ride on a traditional outrigger sailing canoe.

These canoes are still the primary source of transportation in these islands. The locals even use wave patterns to navigate when making overnight passages on them on moonless and starless nights. And they know how to sail these canoes! We had an awesome ride, with the boys showing off and really making the canoe fly. In fact, they pushed the steering paddle to crack, ending our day outing a little earlier than we'd hoped.

From the Louisiades, we had three windy, rainy, downwind sailing days to the Torres Strait that separates Australia and Papua New Guinea. We didn't want to check in to Australia, as many cruisers were complaining that customs was a big hassle and the fees were high. But we did anchor for three successive nights behind various islands, something which is permitted as long as you don't leave your boat. We did this because Alene was hard at work restitching the leech and foot of our relatively new — '10 — North Sails jib, which we'd purchased in New Zealand.

Torres Strait was windy and rough, ***A sailing canoe in the Louisiade Archipelago, now made much faster thanks to the donation of 'Migration's old sails.***



A trading day on 'Migration'.



MIGRATION

MIGRATION

CHANGES

but life changed dramatically as soon as we exited it to the west side. Suddenly we were in Mexico again, with downwind sailing in flat water. Oh, it was

heaven! For days we sailed through the Arafura Sea, flying the spinny with 12-18 knots from astern, and not a swell to be seen. After all those years in the Pacific, we'd forgotten sailing could be so easy.

The sailing conditions in the Arafura Sea reminded Bruce of Baja.

East Timor, which has been trying to get back on its feet after years of strife, was an interesting stop. We found excellent snorkeling at Jaco island on the east end. But at Dili, the capital, the number of people from NGOs and the United Nations, as well as police and military personnel and vehicles, was a bit overwhelming.

The vast majority of boats visiting Indonesia join the Sail Indonesia Rally so they won't have to deal with the paperwork. We found the paperwork wasn't too hard to do ourselves — but it wasn't cheap. We had organized our cruising permit (CAIT) in advance via email, and we hired an agent to handle clearance in Kupang. The latter is a complicated procedure, and friends who tried to do it themselves eventually had to give up and hire an agent.

Besides the flat water sailing after the Torres Strait, the biggest change was the food. For all the delights of the South Pacific, excellence in the culinary arts isn't something that comes to mind. In the Pacific islands you can go a bit crazy on

After the lack of greens in the South Pacific, and the lack of good cooking in New Zealand, Bruce and Alene were thrilled to see Asian markets.



MIGRATION

taro, yam, cassava, and breadfruit. And while we love New Zealand, the food is forgettable there as well. Now, however, we were in Asia, where there was lots of spicy and delicious food — and for little money. As for provisioning, it took weeks for us to get used to the fact that there were markets everywhere selling fresh produce. We didn't have to stock up every time we saw a fresh green.

Indonesia was delightful, and we were frustrated at having so little time there. The Komodo area is awesome, with incredibly good diving, and, of course, the dragons. Surprisingly, the area looks almost exactly like Baja California — especially the way the light falls on the hillsides at sunset.

Bali was fantastic — exotic and with a rich culture. All the islands in the area are fascinating, but Bali deserves a visit of many days. We definitely will return.

We moved north quickly with just a few stops until we crossed the equator, returning to the northern hemisphere after over 4½ years in the southern hemisphere. We were surprised to encounter more dolphins in Indonesian waters than in Fiji or Tonga.

We cleared out of Indonesia at Nongsa, where an excellent little marina took care of all the paperwork. We then crossed the busy Singapore Strait. Singapore is an interesting city-state, but it's one big mall. When it comes to shopping, the locals put Americans to shame. Not exactly our cup of tea. However, the Biodomes and SuperTrees are very cool, and the local food at the hawker stands is incredible.

The Malacca Strait along the west coast of Malaysia was challenging, but we did all right with two night passages and a couple of bumpy anchorages. It's amazing we didn't get hit or hit anything, for the quantity of ships, fishing boats, floats, nets, and debris is staggering. We were there in late October, the transition period between the monsoons, so there were thunderstorms every night. Thankfully, only a few bolts came close.

Langkawi, at the north end of Malaysia, was a fine stop. We checked into and out of the country there, and it was the easiest clearing we've ever done. We also stocked up on beer and rum for friends who were already in Thailand, as

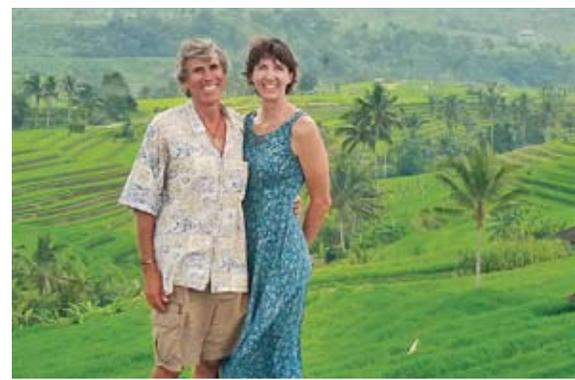

Muslim Langkawi is, curiously enough, a duty-free port. People in Thailand appreciate all the alcohol cruisers can bring north. We then spent a couple of days in the beautiful southern Thai islands, getting in our first swimming and snorkeling in a long time.

We arrived in Phuket on November 10, 98 days after our departure from Suva, and only a week later than we'd originally planned. We'd travelled 5,919 miles and spent 38 nights at sea. Now we'll find a yard for *Migration*, research contractors, empty her completely out, move into a cheap apartment, and give her the big refit she deserves. As long as we've come all this way, we'll do it right so *Migration* has another 40 years on the sea.

There are definitely some challenges on a trip such as the one we did. Moving so fast, it helps to be lucky with the weather. We kept a close eye on it, and we were lucky. Once out of the Pacific and into the waters around Indonesia and Malaysia, the weather is generally benign at the time of year we passed through.



MIGRATION

IN LATITUDES



ALL PHOTOS COURTESY MIGRATION



Clockwise from above: Alene and Bruce, somehow oblivious to the presence of a real, live, mammal-eating Komodo dragon right in front of them. Komodo dragons have a nasty stink eye, sharp claws, and toxic saliva. The couple in the rice fields of Bali. Alene with a dolphin in Indonesian waters.

But there are a lot of calms around Indonesia and Malaysia. Because we were in a hurry, we ended up motoring more than in the previous 18 months. And all that motoring means fueling — often by jerry jug — which can be tiresome. We certainly wanted to stay longer in every place we visited. We had to keep telling ourselves we'd see them on the way back. That's another challenge — how to get back to the Pacific? There's so much more we want to see in that ocean. But we'll deal with that after the refit.

However, this trip has made very clear our biggest problem — there are just too many intriguing, amazing, fascinating places to visit in the world. How can we decide where to go next? But at least that's a pretty cool problem to have.

— bruce 11/01/12

**Second Chance — Hylas 46
Dick Oppenheimer, Linda Dalton**

Sailing the Maine Coast (San Francisco)

As we write, it's early October in Camden Harbor, Maine. The famous 'windjammer' schooners have been covered in shrink wrap. Brilliant yellow, red and orange leaves are dropping. And the temperatures have definitely cooled. All are signs that sailing here is finished for the season. So it's time to haul our Hylas 46 *Second Chance*, and place her in a covered shed for the winter. Once that's done, we'll return to San Francisco, having enjoyed another wonderful summer of sailing.

Just a month earlier, a small fleet of historic, lovingly restored wooden ships sailed past our moor-

ing and into the harbor for the annual Camden Windjammer Festival. *Victory Chimes*, a magnificent 132-foot three-masted schooner, glided her way into the harbor with her yawl boat maneuvering her through the mooring field to the city waterfront. The yawl boat provides power for the schooner when needed. With a hand on the tiller, crewmembers can gently nudge an engineless tall ship forward and into her slip. It was an extraordinary sight to see the schooner come into port, and a wonderful demonstration of skilled seamanship on the part of captain, crew, and yawl boat drivers.



A yawl operator guides a windjammer into her berth.

Even after several months in Maine, it feels as though we have just begun to explore this extraordinary cruising area. With almost 3,500 miles of scenic coastline, thousands of pristine islands, and the only fjord on the East Coast, there is no shortage of beautiful anchorages in this state. Wildlife abounds, and it's not unusual to see osprey, bald eagles, porpoises and seals.

While it's difficult to pick a favorite spot in Maine, Northeast Harbor stands out as a place of exceptional beauty. It is to the east of Somes Sound on Mount Desert Island, and is one of the major yachting centers in Maine. It is home to a small fleet of beautiful pleasure craft as well as working lobster boats. With Morris Yachts located near the town slips, there is a constant stream of Morris vessels on show.

Since it's water-oriented, Northeast **Dick and Katie Oppenheimer on 'Second Chance'. What could be more satisfying than cruising Maine with your grandchildren?**



SECOND CHANCE

SECOND CHANCE

CHANGES

Harbor has all the facilities, services and shops that a sailor could want, all located just a short walk from the harbor. A free shuttle takes passengers from the harbor to Acadia National Park, home to many fine hiking trails, as well as to the neighboring villages of Bass Harbor, Southwest Harbor, and Bar Harbor.



Lobster buoys.

There are a number of challenges that make cruising 'Down East' unique. They include thousands of lobster traps, dense fog, a tidal range in excess of 12 feet and unmarked rocky ledges. Established lobster fishermen are allowed a maximum of 800 traps, with no apparent restrictions on where the traps can be set. Lobster buoys can be found in open water as far as 15 miles offshore, in the middle of mooring fields and scattered in narrow channels. 'It's not if, but when, your boat will get tangled in a lobster line,' is a famous local saying.

Outside of Stonington, a small fishing village that boasts the largest lobster catch in Maine, *Second Chance* became entangled in a 'double buoy'. To make lobster trap retrievals easier, a second buoy is sometimes tethered to the first buoy by a slightly submerged line five to eight feet in length. It's that line we got tangled in. After conferring with lobstermen on a nearby boat, we contacted a Stonington marina for assistance. Several attempts to untangle the line were unsuccessful, so we reluctantly started the engine and engaged the line-cutters on our propeller shaft, severing the line to release our boat. Unfortunately, it was

The lobster catch has been at record levels for the last two years, driving prices way down — except in restaurants, of course.

not possible to reattach the lines marking the traps, which we wanted to do in order to save the fisherman's investment of \$200.

The last two summers saw record lobster catches in Maine, with the overabundance causing wholesale prices to plummet to as little as \$2/lb for the fishermen, while the retail price remained around \$6/lb. Restaurants certainly didn't pass on their lobster savings to customers.

Dense fog is common in Maine and can descend quickly, reducing visibility to just a few feet. We managed to navigate safely using our eyes, ears, radar, an AIS receiver and a chart plotter. But there were still some close calls with sportfishing boats.

While cruising the Gulf of Maine in dense fog on our return trip from Yarmouth, Nova Scotia, we tracked a 980-foot Disney cruise ship on our radar and AIS receiver as she moved through the water in excess of 22 knots. When she got within two miles on a converging course, we contacted her on VHF radio to verify that the crew were aware of us and that we would pass safely. To be more noticeable to commercial traffic, cruise ships' and high-speed ferries in reduced visibility, we'll be installing an AIS unit that doesn't just receive AIS signals, but transmits ours as well.

Even the most popular and picturesque harbors in Maine can contain hidden ledges and rocks. Beautiful Bucks Harbor, which seems almost unchanged since Robert McCloskey featured it in his 1952 children's' book *One Morning in Maine*, has a particularly hazardous ledge. Located in the middle of the mooring field, it's covered by about four feet of water at low tide, and surrounding boats often obscure the orange and white marking buoy. Entering the harbor at low water early in the summer, we narrowly missed the ledge. When we returned two weeks later, we learned that two boats had gone hard aground until they were lifted off by high tide. To enhance safety, the harbormaster installed a large inflatable orange buoy with 'LEDGE' written on the side. It's not very elegant, but it's effective.

Even though we've just left Maine and Nova Scotia, we can't wait until we

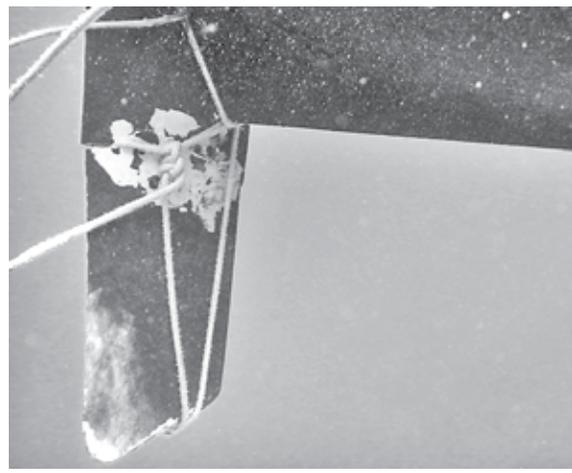

return next summer for another season. We think it's wonderful!

— dick and linda 10/25/12

Panache — Catalina 30 Zach Lough Four Wild Minutes Off Niue (Ventura)

I'm an ultra budget cruiser who took off with the Ha-Ha in '11, shortly after my girlfriend dumped me and backed out on our cruise. I've nonetheless made it much of the way across the South Pacific with countless adventures, which you can read about and see photos of at www.sailpanache.com.

My most recent — and nearly last — adventure took place in October at Niue, a remote island-country in the South Pacific where you have to take a mooring buoy because there is no place to anchor. In poor weather, such as we had, even being on a mooring buoy isn't much fun. Here's how the adventure went down:

Dinghying back to the boat was a bit

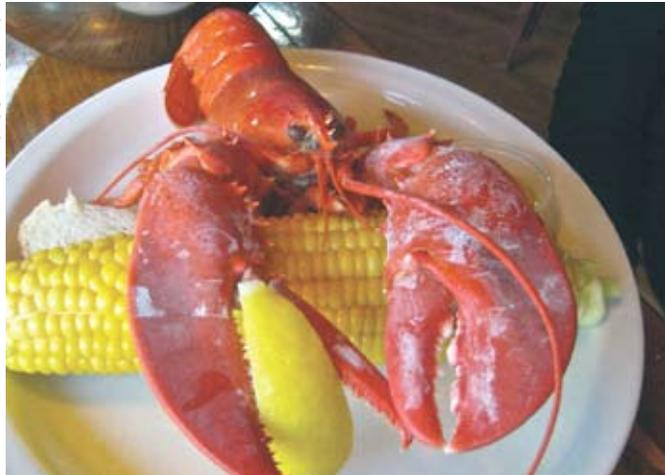

IN LATITUDES

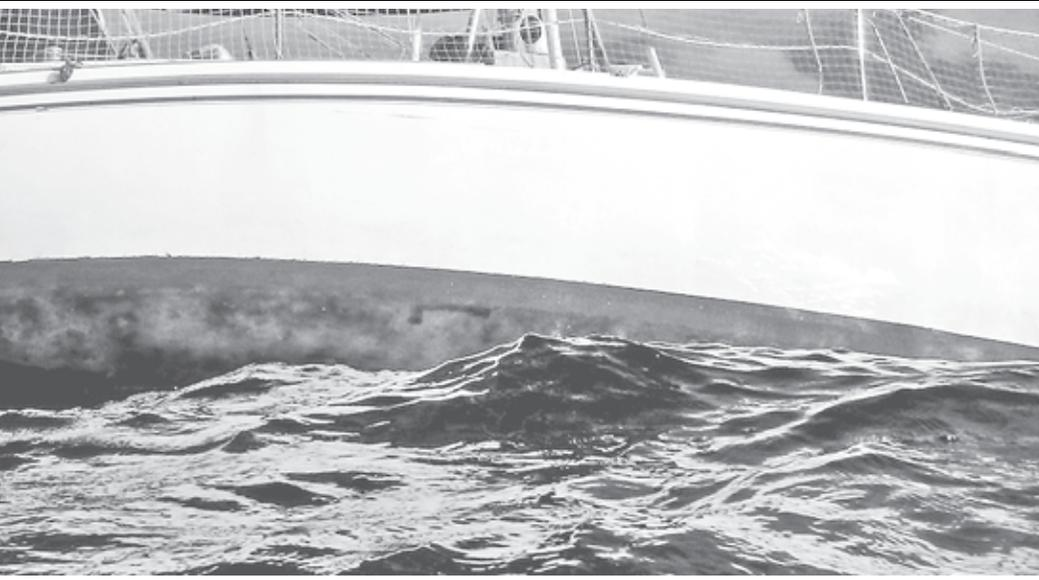

ZACH LOUGH

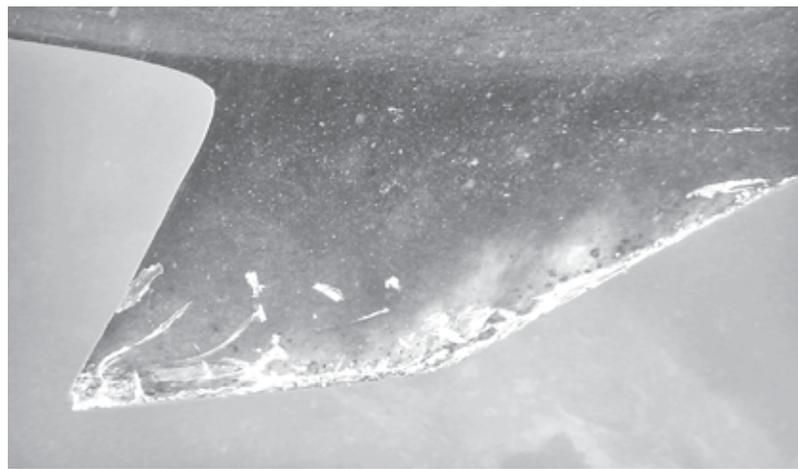

'Panache', a 38-year-old Catalina 30, made it all the way to the South Pacific before she was rocked by a few minor problems.

strange in such colossal swells, particularly since there was no light to see them coming. *Panache* rocked back and forth violently, so getting aboard was a task in itself. The wind was from the north and the swell from the northwest, which kicked *Panache* around just enough to make sleep impossible.

I had to get up in the middle of the night for a breather, as a can of spray paint clinking back and forth was keeping me from sleeping. No matter how I moved the can or packed material around it, the sound of that little mixing ball inside continued to keep me up.

"While on deck, I checked the boat's line to the mooring ball. The mooring was a refrigerator-sized block of concrete with a nylon rope, with an eye splice on a metal thimble to tie off to. *Panache* would periodically stretch the mooring line taut. Each time she reached the end

of the line, I was jerked more awake. As I climbed into the cabin to go below, I was careful not to step on the bundle of papayas my crew Vlad and I had put in the cockpit in case they had bugs intent on stowing away. With so many papayas, there really wasn't any other place for them!

Throughout the night I woke up periodically and made a visual sweep of the surroundings. Same waves, same wharf being beaten by the waves, nothing new of note. My crew Vlad and I never fell asleep, but we did fall into a limbo dream state where our brains were just conscious enough to lurch into action if need be. This must be how most animals sleep. In our state of grime and sleep deprivation, Vlad and I felt like animals.

Little did Vlad and I realize that during one of our partial dream states the rocking of the boat had

slowly untied the line between *Panache* and the mooring line. Like a blind man walking toward a cliff, *Panache* slowly and unnoticeably rocked toward the hard, coral shore just 100 feet away from the mooring.

I don't know what I was dreaming about, but the most terrible sound woke Vlad and me at the same time. It was as if a wrecking ball were ramming the bottom of the boat! Our animal sleep broken, both of us shot up.

BANG! With the force of a cannon blast, the wrecking ball struck again, jolting the whole boat like an earthquake. "We're on the reef!" Vlad shouted in a shaky voice. Never had my heart sunk so fast or my adrenaline risen so high in the same instant. Smashing your boat on a reef is a sure way to end your cruise quickly. And if it doesn't sink your boat, it will sink your cruising ambitions.

"Wow! Wow! WOW!" Vlad couldn't stop yelling the same thing each time the reef battered the keel. Noting that the bow was pointed toward the reef — meaning the prop was in deeper water, I screamed at Vlad to turn the engine on. "Now!!!" I kept hoping that I was just having a nightmare.

Vlad instinctively turned the ignition. "It doesn't work!" he shouted. "Should we call for help!?"

"What do you mean the engine doesn't work?!!" I responded sternly. As I hopped into the cabin to get the engine started, a wave pushed us deeper onto the reef, shoving *Panache* over at a 40-degree **A condom every time you have sex. And, as Zach's crew Vlad would probably agree, double check the knots every time you moor.**



Zach was red-faced with embarrassment about the incident.

LATTITUDE/RICHARD



PANACHE

CHANGES

angle and dumping all of our belongings in the cabin onto the sole.

Noting that Vlad hadn't turned the battery on for the engine, I did, and the engine immediately came to life. I jumped into the cockpit, wrenched the tiller to center, and threw the engine into

reverse.

Every wave was accompanied by the terrible noise of the reef trying to shatter *Panache's* fiberglass hull. My jaw was clenched together in solidarity with *Panache*. "Come on. COME ON! COME ON!!!" I kept urging through my teeth.

With each wave we crept farther toward the point of no return. It wasn't working.

"We need to call for help!" Vlad insisted. I turned the engine off and did what every sailor fears — make a Mayday call.

"Trying to steady my hand, I picked up the VHF radio. Then it was time to steady my voice: "Mayday! Mayday! Mayday! This is the sailing vessel *Panache*. We have two persons aboard. We broke from our mooring in Alofi Bay and are on the reef. Requesting assistance. I repeat, we are on the reef and requesting ..." BANG! "assistance!"

I paused for a moment but got no response. It was 3 a.m., but I figured somebody had to be up and on 16.

"Should we abandon ship in the dinghy?" Vlad asked.

"No, it's safer on the boat for the time being," I answered quickly. I repeated the Mayday, and again got no response.

The interior of 'Panache' might have ended up a smelly mess, and Zach might have been totally wiped out, but his Catalina 30 would survive.

"Fuck it," I announced, "I'm getting us off this fucking reef!" Then I turned the engine back on.

Panache wasn't totally on her side, and because the reef was steep, if I gunned the engine in time with the waves, I thought I might be able to shimmy her free. Giving the prop every ounce of horsepower available at the right instants, I soon could tell that we were slowly making progress.

Then I looked aft and saw a huge black mass heading for us. Before the wave struck *Panache's* stern, the water under us was pulled into the black mass, and the tiller twisted violently into my side. There was a loud SNAP! — the sound of *Panache's* tiller shattering like a Louisville Slugger being destroyed by a fastball. The tiller then hung on by a thread. But that last big wave had been enough to lift *Panache* off the reef! We were moving in reverse. We were free, but were we slowly sinking?

I instructed to Vlad to check the cabin sole for water. There was a little, but nothing like in a Hollywood movie. "Shit. It's the toilet water!" said Vlad. During all the commotion, our plugged up toilet had dumped its smelly contents onto the cabin floor. But at the moment, it was the least of our problems.

"We need to anchor, but those moorings can't be trusted." I said. Right then I saw mooring ball #1, the one we had been on. And I quickly noticed that there was nothing wrong with it. It was the knot that had attached *Panache* to the mooring that had failed. The knot that I had tied!

What a sinking feeling!

We limped to the mooring ball and attempted to attach ourselves, only managing to tangle our dinghy with the mooring line. Another clusterfuck! We were stern-to to the swell, making *Panache* roll dangerously. We needed to fix

this, but first we needed to remove from the cockpit all the papayas that we had smashed into the world's largest fruit salad. Vlad and I dug out the papayaed cockpit like dogs digging to China, not realizing we had flung half the smashed papayas into the dinghy. Whatever.

I hopped into the dinghy and started untangling the rat's nest of knots that were prevent-



ing us from making a second approach to the secure mooring. It was bad. The dinghy smashed against *Panache* as *Panache* rolled violently into the dinghy, all while I tried to free us from the mooring, covered in papaya. It was madness.

After what felt like an eternity, the knot was straightened out and *Panache* was once again drifting back toward the boiling breakwater. We definitely had steering problems, but we managed to inch forward once again and secure ourselves to mooring ball #1, this time with two lines and extra tight cleat hitches.

Exhausted and letting our heart rates return to normal, Vlad and I congratulated each other for moving quickly. It was time to call off our Mayday to Niue Radio, which by this point was getting lots of attention. We disinfected the cabin sole with bleach and sat on deck to hide from the fumes while doing a play-by-play breakdown of the four minutes of madness.

I couldn't help thinking about all the things that, had they been slightly dif-

PANACHE

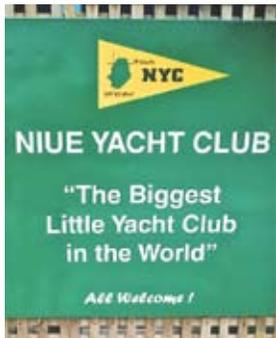

Niue is home to...

PANACHE



IN LATITUDES

PHOTOS COURTESY PANACHE

ate plans sequenced between scuttling *Panache* and flying home from Niue, fixing the boat in Tonga and waiting out the cyclone season, and everything in between. Whichever way, landfall in New Zealand had never felt so far away. I had failed.

— zach 10/10/12

Readers — So ends Zach's report. In a private email, he wrote to say that his cruising was probably "winding down." Since then, Vlad has flown home, Zach has gotten the rudder fixed, and he has checked out of Niue for Tonga. We're thinking that New Zealand, after the South Pacific Tropical Cyclone Season ends, might not seem that distant any longer.

Zach is too young to realize that he's not been a failure at all, but a raging success. No matter what he decides to do, the responsibilities and experiences he's had in the last year have given him not only a bigger bang-for-the-buck education, but a better real-life education than he could have gotten at Harvard. But even more important, dude, you've been living life to the hilt, not just existing. A tip of the Latitude hat to you.

**Angel Louise — Catalac 36
Ed and Sue Kelly
Doing the European Divide
(Des Moines, Iowa)**

We write from the islands of Greece, the 34th country on our ship's log. Getting *Angel Louise* to the Aegean Sea has been worth the effort, but it's been a different kind of effort than we anticipated — and it involved a route that we had never read about before. Capt Sue and I have the distinction of having taken our sailboat from the North Sea to the Black Sea and Southern Turkey, which required crossing the 1,340-ft-tall Continental Divide by four principal canals

'Angel Louise' may not be the newest or sleekest cat, but she's gone from Maine to Venezuela, across the Atlantic and across Europe.



The aftermath, clockwise from above. Vlad and Zach with the rudder at the Niue YC. A triumphant Zach found it was easy to drop the rudder from the boat. The major rudder damage was the shape of Texas. Zach at the Niue YC work table. Three aluminum stringers for extra strength.

ferent, would have prevented *Panache* from going on the reef. If we had only left Niue with Elliot, or tied the mooring line tighter, or kept an anchor watch on deck, or turned the engine on a moment earlier, we might be in better shape. But all things considered, we were extremely lucky, because we were both safe and *Panache* was still floating. Our exhaustion was overwhelming, but sleep never came. Fear of breaking free from the mooring was enough to keep us both awake.

I jumped into the churning water the following morning and, when the bubbles cleared, could see the damage. *Panache's* keel looked as if the shark from *Jaws* had chewed it apart, and there was a superficial scar on the bow. The bad news was that the rudder was fractured. I took a few pictures and then hauled myself on deck. New Zealand was out of the question. I had gotten lazy, tied a shitty knot, and lost New Zealand. It

may sound silly, but losing New Zealand made my time in the Pacific seem like a waste. It's like hiking to within visible range of a mountain's peak, and then having to turn around.

We would have to remove the rudder and jury rig a fix good enough to get us to Tonga 310 miles away. Before any of that, though, we would have to wait out the low pressure system that was twisting the wind and waves into two days of torture. No toilet, no sleep, and all the luxuries of land teasing us by being only meters away.

The wharf was being swallowed by the westerly swell, making a landing suicide. Grudgingly we waited out the low, all the while awake and overly vigilant of the lines connected to our mooring ball keeping us away from the reef. I had plenty of time to be bummed out, and my immedi-



ANGEL LOUISE

CHANGES

and rivers of Europe. In the process of traveling up the Rhine and down the Danube, we learned new skills in poorly charted areas, while often testing the laws and regulations of nine different countries. We hoped the trip would be uneventful, but it proved to be anything but.

Capt Sue is a retired nurse practitioner, and I'm a retired assistant United States attorney. Having been inspired by the stories in *Latitude* and the philosophy of the publisher of *Latitude*, Sue and I bought *Angel Louise* in Maryland in the fall of '07 to be our movable retirement cottage until it wasn't fun anymore. We haven't looked back. Our quarter-century-old *Angel Louise* was the 26th of 27 Catalac catamarans built by Tom Lack of Christchurch, England.

We'd done five years of cruising prior to our European adventure. Our previous trips took us up and down the Intercoastal Waterway from Maine to Florida several times, and we spent two years cruising in the Eastern Caribbean as far down as Venezuela and the ABC Islands. By the summer of '11, we'd finally garnered enough courage to cross the Atlantic. It took 38 days, not counting the time we spent in Bermuda and the Azores. We then spent six winter months at London's St. Katherine Docks.

Even before we got to England, we'd dreamed of doing the French canals in the summer of '12. But those plans were dashed when we discovered that *Angel Louise* was too wide and tall to transit the locks and key canals of France. We were crestfallen. But the next morning we saw an ad in the *Sunday Times* for a trip from Holland to Romania aboard a River Hotel ship. It was as though the ad were put there to give us another way to achieve our dream.

We looked closely at the ship's picture and Sue have taken their "retirement cottage" to 34 countries so far, and will add to that number as long as they're having fun.



tures and route, and found that our cat was nowhere near as wide or tall. Despite our boat's tall traveler and antennas, we decided that she could make the trip. The fare for the River Hotel trip was \$14,000 per couple. I told Capt Sue that I would take her for free. There are always advantages for those who get to sleep with the captain.

While living aboard in London, we joined the English Cruising Association, The Royal Yacht Association and the Dutch Barge Association, and attended two lectures by the owners of two English boats that had made the trip. We found that Euro-critters are ethnocentric. For example, none of our U.S. Coast Guard licenses were acceptable. European authorities require an International Certificate of Competence (ICC), of which there is a separate one for inland waters and canals, and they also require a separate endorsement for sail. And unlike in the United States, you have to pay for examiners to test your skills on the water. You also have to pass a CEVNI written test showing you know lock and canal signals and rules. Having sailed our boat from the United States to England, it would have been comical for us to take a test to prove we knew how to sail — were it not for the fact that we were charged over \$1,000 U.S. for both licenses.

Early research revealed that only a handful of pleasure boats had made the trip by the rivers that we proposed, and most of them were powerboats with much larger engines. And a majority of them got to the upriver Rhine in Germany via canals. Boaters familiar with the Rhine warned us not to even try our proposed route with just two 37-hp Yanmar diesels, as they said we wouldn't have enough power to get our heavy boat past the Rhine's fabled Lorelei Rocks. But a few more adventurous folks encouraged us to give it a try, although they cautioned it would be a hard and slow trip for us. We even considered — briefly — putting a mount on the back of *Angel Louise* for our 15-hp Yamaha.

We finally decided that we would make the effort without being assured of success. If we couldn't get past the Lorelei Rocks, we'd just consider it another adventure, turn around, and head to the Med via the Atlantic.

We're happy to report that



Angel Louise turned out to be the little train engine that could. We discovered that we could make better headway in the areas of greatest current by weaving back and forth. But it was eerie and disconcerting in several places on the Rhine when it would take us a full minute for the length of our boat to pass a river buoy.

We had to much to learn. For example, if your boat is less than 45 feet long, she is free from the river regulations governing larger vessels. And the locks would be free for our cat, but pleasure boats have no right-of-way in any circumstances on the waters. And lock keepers would let us go into the locks after the larger ships if there was space, but we would always have to wait for a commercial ship going our way through a lock to use it.

With that introduction, we hope you'll read next month's report on our actual trip.

— ed / 11/15/12

IN LATITUDES



PHOTOS COURTESY CABO YACHT CENTER

Spread; The rudderless Hylas 46 'Sea Silk' being towed from Mag Bay with a harness to distribute the tow load. Insets left; The sloop's protective skeg very likely prevented greater damage to the rudder. While the hull and keel were damaged, it was only superficial in both cases.

Cruise Notes:

If you're unlucky enough to be caught in a remote area when a hurricane blows through, and your boat gets driven ashore, you're going to need a lot of things going for you in order to have a good outcome. Among them are decent weather, a responsive insurance company, a good rescue company, a powerful tow vessel, and helpful local authorities. Fortunately for Craig Blasingame and Sue Steven of the Coronado-based Hylas 46 **Sea Silk**, who were aboard with three friends when their big sloop was driven ashore at Mag Bay by October's hurricane *Paul*, they got all of them.

"Markel, the insurance company for the boat, was very responsive, as they called us the next day and told us to do whatever we needed to do to save the boat," explains Ari Kreiss of the **Cabo Yacht Center**. It was Kreiss and his

team who ultimately pulled *Sea Silk* free, towed her 170 miles to Cabo San Lucas, and are now repairing her. As the boat was stranded at Isla Santa Margarita, an island that forms the western shore of Mag Bay, they weren't able to use a backhoe to dig a trench for the boat to deep water, so they blew and dug the dirt out of the way. "We then rigged a harness to distribute the tow loads all around the boat, and pulled *Sea Silk* off with a powerful triple-screw 110-ft work boat," says Kreiss. "*Sea Silk* came off in better shape than any big boat we've pulled off a shore. The greatest damage was to the rudder, which had broken in half. There was also some relatively minor damage around the keel, some cosmetic damage,

and a little water inside. But in three weeks she'll be repaired and her owners can continue the one-year cruise they had started."

Kreiss noted that *Sea Silk* had gone up in about as ideal a spot as possible, and that the Mexican Navy, which has a base half a mile away, took extraordinarily good care of the boat and the five people who came off it in the storm. "The Navy put the crew up, fed them, and did everything they could for the owners." Viva Mexico!

While we were having a *cerveza* in the Baja Cantina in Cabo, a man sat down next to us and said "hello." It was Bob Barry, who knew us because he'd done the '06 Ha-Ha with his Beneteau 523 **Latitude 23**. When we asked him where he'd sailed since the Ha-Ha, he told us mostly around Cabo San Lucas.

"I started a day charter business out of Cabo in '07 with a Mexican partner, and two years later I bought him out. Despite all the competition, and the fact that I'm not Mexican, it's been a good business for me. A lot of my friends told me that I'd go crazy after I was in Cabo for a month, but I have a lot of friends and I like it here." Barry tells us that he gets most of his business from TripAdvisor, where his charters are ranked high on the list of popular activities in Cabo. Nonetheless, when the onetime Merrill Lynch employee gets his boat paid off in a couple of years, he says he'd like to buy a catamaran and sail the Caribbean.

Is hoisting **your dinghy and outboard** for the night no longer enough?

"On November 12 we had our grey Achilles inflatable and her 9.8-hp Tohatsu outboard stolen while we were anchored at Isla de Piedra outside Mazatlan," report John Gratton and Linda Hill of the San Francisco-based Hans Christian 33 **Nakia**. "The theft

One way to lose your dinghy/outboard in Mexico is to ride it into a wave. Another is to have it stolen. Both are expensive propositions.



CHERIE SOGSTI

CHANGES

occurred at 12:30 a.m. local time, and the method was unusual. Our dinghy was raised high out of the water on a halyard, and the outboard was locked to the dinghy and then cabled and locked to *Nakia* with 3/16-inch lifeline wire. The thieves placed their *panga* beneath the raised dinghy, cut the bridle suspending the dinghy, then cut the cable from the dinghy to the boat. I was woken up by the sound of the cable pulling tight on *Nakia*, and was on deck in time to see the thieves cut the cable and race away in their *panga*.

John and Linda report they've been cruising Mexico since '04, and this was the first time they'd had anything stolen. But they were disappointed, because the only reason the outboard hadn't been mounted and locked to the back of *Nakia* is that shortly after sunset John had taken their inflatable to help a vessel in distress. As like Mark Twain said, no good deed goes unpunished.

For the sake of others, if your dinghy is stolen in Mexico, please let us know so we can alert everyone to possible hot spots and techniques used to steal dinghies. Historically, dinghy theft has not



CHERIE SOGSTI

Barritt Neal, who has cruised Mexico, the South Pacific, and the Caribbean, says the folks at Cruiseport Marina treated him like royalty.

been a big problem in Mexico, so let's work to try to keep it that way.

Are **cell** and **data antennas** stronger in Mexico than in the United States? It seems like it. Twelve miles after leaving

Cabo for Puerto Vallarta aboard **Profligate**, we were still talking on the phone and surfing the Internet with our Telcel modem. That's about 11½ miles farther offshore than when we sail south of Pt. Loma. And Renee Neal of the San Diego-based Peterson 44 **Serendipity** reports that she was reading her Facebook page — using her Telcel modem — while sailing down the length of the east coast of remote Cedros Island at 4 a.m. "There Barritt and I were, motorsailing along under a full moon, having a great time, and all my girlfriends were writing about how worried they were for me."

We met up with the Neals and buddy-boaters Chip and Katy Prather of the Dana Point-based Morgan 45 **Miss Teak** while at Punta Mita, and both couples had nothing but great things to say about their current cruise in Mexico. They all raved about **Cruiseport Marina** in Ensenada, whose staff drove them — at no cost — to and back from the immigration/port captain's office. "In all ways the Cruiseport folks treated us royally," says Barritt. Their big discovery at Turtle Bay was the **Annabelle** family's

Mast Mate™

Climb Your Mast Alone with Mast Mate
Made in the USA for 20 Years

Satisfaction Guaranteed

(207) 596-0495
www.mastmate.com

MARINA DE LA PAZ
FULL SERVICE MARINA

Friendly, helpful, fully bilingual staff

Hardwood docks • Protective piling & sheetpile breakwater
Plug-in Internet • Dinghy landing • Cruisers' clubhouse
Electricity • Potable reverse osmosis water • And more!

TEL: 01152 612 122 1646
email: marinalapaz@prodigy.net.mx
www.marinadelapaz.com
Apdo. Postal 290, La Paz, 23000
Baja California Sur, Mexico

Official Sponsor
2012
BAJA
HA-HA

weatherguy.com

Worldwide Marine Forecasts
Cruising, Racing & Commercial
Packages Starting at \$65.00 USD

(866) 882-WXGY (9949) toll free
(808) 291-WXGY (Mobile)
(808) 254-2525 (Office)
(808) 443-0889 (Fax)

970 N Kalaheo Ave
Suite C-104
Kailua, Hawaii 96734
info@weatherguy.com

www.weatherguy.com

1,000 Used Sails
Listed at
minneysyachtsurplus.com

We Buy Good Used Sails
and Marine Equipment

MINNEY'S YACHT SURPLUS
1500 Newport Bl., Costa Mesa, CA
949-548-4192 • minneys@aol.com
"We keep boating affordable!"

surprisingly large restaurant on the bluff above the cove just to the west of the pier. "Annabelle's food was delicious, and it was inexpensive," says Chip. They also bought diesel from Annabelle that was delivered to their boat at \$3.40 a gallon, a price that will give Californians a case of energy envy. Having already spent a lot of time in Cabo, both boats passed by this time in favor of **Puertos Los Cabos Marina** at San Jose del Cabo. They found that marina assistant manager Shirley Collins runs a pleasantly tight ship, and they enjoyed the less touristy town.

The crews of the two boats had the biggest laugh at **San Blas**, where they saw an enterprising man riding around on a three-wheeled bike while smoking marlin on half a 55-gallon drum mounted on the bike's handlebars! The man does this every day, and goes around selling the fish on a route. When he dropped five pounds off at a restaurant, the four cruisers asked if they could have a nibble to see how the marlin tasted. In typically stranger-pleasing Mexican fashion, the woman who ran the restaurant lifted a big chunk of the smoked marlin right

from her husband's lunch plate and gave it to the cruisers to taste. Yum!

The Neals and Prathers loved their stop at **Chacala**, where the water was astonishingly warm. Then they rounded the corner of Banderas Bay to anchor at **Punta Mita**, where they found themselves in company with two Mexican naval vessels. The vessels were part of a security team for President-elect **Enrique Peña Nieto**, who was about to take office, and Felipe Calderón, the outgoing president, both of whom were staying at that the St. Regis Hotel in the so-called Four Seasons complex. The Neals and Prathers are loving Mexico as much as, if not more than ever.

"When cruisers apply for U.S. passports, they should get business pass-



Food trucks are so old sombrero! Wait until Mexican 'smokers on bikes' catch on in the States. Fresh smoked marlin — so tasty!

ports, not the regular ones," advise Jim and Kent Milski of the Lake City, Colorado-based Schionning 49 **Sea Level**. "We were almost denied entry to South Africa because our passports were full," they write. "We had to get the American Embassy in Durban to glue some additional pages in. When we first got our passports, we could have gotten the

Your Boatyard in the Heart of Paradise



Large, fenced, secure dry storage area

Tahiti Customs policy has changed!
Foreign Flag vessels can stay on dry storage in our yard for up to 12 months out of 24.

Our Services |

HAULOUT

- Marine Travelift 25 tons
- Marine railway 120 tons
- Storage in adjustable steel cradles
- Fenced Yard

PAINTING

- Topsides, hull, bottom, varnish
- Brush, roller, spray

MECHANICAL WORK

- Inboard, outboard, diesel, gas
- All brands

REPAIRS

- Electrical repairs
- Refrigeration installation & repair
- Fiberglass & woodwork
- Welding, steel, stainless, aluminum

SAIL LOFT

- Sail repairs, biminis, dodgers, covers

STORE

- International, Pettit, Epiglass, Devoe
- Spares
- Fill U.S. gas cylinders

DO-IT-YOURSELFERS WELCOME!

BoatUS Cooperating Marina



Professional boatyard in the heart of Paradise



A Subsidiary of
The Moorings Yacht Charter, Ltd.

Raiatea Carenage will make sure
paradise is everything you expected.

Call, write, or sail in . . . we're here to serve you.

B.P. 1111 Uturoa Raiatea 98 735 Polynésie Française

Tel: (689) 600-545 ~ Fax: (689) 600-546 ~ VHF 68

Web site: <http://www.raiatea.com/carenage> ~ email: raiateacarenage@mail.pf

CHANGES

business version, which costs no more but has 32 extra pages. We've learned that European Union airlines won't let anyone fly to South Africa unless they have at least four blank pages in their passports. Anyway, we're currently at the international check-in dock, which is free but not very secure. But it's the only place that has space available for our cat. We could tell lots of tales of nasty seas getting here, but we're off to see lions, leopards and elephants, our daughter Samar will join us for Christmas in South Africa, and we think we'll make it to the Caribbean by March or April."

We presume the docks in South Africa are crowded because most circumnavigators still think that the only other option — going by way of the Red Sea and the Med — is still too dangerous thanks to Somali pirates. While piracy is way down, it's not out, and most cruisers don't see the risks of the Red Sea route as outweighing the rewards yet.

"October 14 was an interesting day here at Boca Chica, Panama," reports William Nokes of the Chetco, Oregon-based Gulfstar 41 **Someday**. "I was



FORGERIES R US

When applying for a passport, get the 'business class' upgrade. It's free, and the extra pages could save you a major inconvenience.

running the engine to charge the batteries when Pamela Bendall's Port Hardy, B.C.-based Kristen 46, **Precious Metal**, a vet of the Ha-Ha as well as cruising in Central and South America, motored in

behind a sailboat named **Rapscallion**. To my surprise, they passed through the anchorage — apparently on their way upriver to Pedregal — without responding to calls on VHF 16. Both Derek of Seagull Cove Resort and I tried hailing them on a variety of channels, but got no response. Derek finally jumped into his small boat and took off after them, wanting to make sure that they knew of the local hazards. Obviously they didn't, because Derek caught up with them just in time to see *Rapscallion's* mast take down the power line, and then *Precious Metal* go aground on a reef. It took several hours, but we finally got her boat off the reef and anchored. The fact that *Precious Metal* is a steel boat may have saved the boat's life, as she suffered no leaks."

Nokes, who writes a frequent and very readable blog from onboard in Panama, reports that it's possible to continue on past the Boca Chica anchorage the seven or so miles up the windy Rio Garibaldi to Pedregal and the big metropolitan area of David. But you do need the latest local knowledge to do it safely.

Who needs the **mainland**?

Let Hydrovane sail you home safely.

WHAT IF...

- Autopilot fails
- Batteries are dead
- Engine won't start
- Steering broken
- Rudder is damaged
- Crew incapacitated

NO WORRIES WITH HYDROVANE

Totally independent self-steering system and emergency rudder... in place and ready to go.



← Larry and Nelda on Diamond Girl, their Beneteau 393, in Paradise Village, MX March 2012

"The Hydrovane exceeded all our expectations! In over 600 hours of use it did not lose our course a single time!"

- Larry upon arrival in the Marquesas



WWW.HYDROVANE.COM

1.604.925.2660
info@hydrovane.com

SURVIVE YOUR DREAM



#1 Selling LED Brand



The Navy specifies the use of Dr. LED's lights.

Shouldn't you?



www.DoctorLED.com



Spread Joy Around the World this Holiday Season!

Take a bundle of **Latitude 38** magazines with you on your winter travels!

Magazines can be picked up for free at our office at 15 Locust Ave. in Mill Valley. For directions or to make other arrangements, call us at (415) 383-8200.

"I sailed down in the '11 Ha-Ha with plans for open-ended 'commuter cruising' in the Sea of Cortez," writes Jimmy Peter of the Malibu-based Pacific Seacraft 37 **Island Time**. "After the Ha-Ha ended, I quickly left the noise and madness of Cabo for San Jose del Cabo. It was like exhaling. Cruisers told me that if I liked San Jose del Cabo, I would love La Paz. I did love La Paz! Initially I had a very busy cruising itinerary, with lots of anchorages, fishing villages and ports to check off my list. But whereas I used to just stay one night in places, I now spend two, three, and even four nights. And I now think an anchorage is crowded if there are more than three boats. I love the weather in the Sea, although I've gotten an education in how to deal with the *coromuel* winds and the sudden and strong *chubascos* and *elephantas*, as well as the brutal heat of summer. I also learned that *siestas* make so much sense! I might make it over to the mainland this winter, but if I don't, that's cool, because I still have so much more to see in the Sea. The one thing I'm going to do for sure is cruise farther up into the Sea

this spring and summer."

If you've been sailing in Mexico this winter, you know that the air and water temperatures have been unusually warm. For instance, the Prathers' thermometer read 86 degrees at Punta Mita, which is about 12 miles from Puerto Vallarta, and an astonishing 87+ degrees at Chacala. We don't know if *Miss Teak's* thermometer needs recalibrating, but we do know that surfers and SUP-ers are hitting the waves at dawn sans wetsuits and staying out until noon! Warm water means big fish. In April, Robert Pedigo landed a 428 lbs yellowfin tuna on the Puerto Vallarta-based sport-fishing boat **Journeyman**. In September, Dana Point's Guy Yocom landed a 428 lbs yellowfin at Cabo. The latter is the new International Game Fishing record because a deckhand had touched Pedigo's rod during his fight, disqualifying it for a record.



Lots of sailors slag on Cabo. We loved it when only 12 people lived there, soured on it during the transition, but now love it again.

Having sampled plenty of yellowfin, dorado, and yahoo during this year's Ha-Ha — thanks to the fishermen aboard *Profligate* and other Ha-Ha boats — we've decided that wahoo (ono) makes the best sashimi, but nothing can compare with Dino's baked yellowfin tuna.

There was sad news out of La Cruz in mid-November, as **Dick Schubert**, a lifetime member and staff commodore of the Half Moon Bay YC, passed suddenly as

AQUAMARINE INC.
Watermakers Since 1987

SPARKLING FRESH WATER, POWER, AND REFRIGERATION FROM THE SEVEN SEAS

AQUAGEN 150

MODULAR KIT

HYDRAULIC

316 S/S REMOTE PANEL

12 VOLT DC

AquaGen combines the quality, simplicity & reliability of AquaMarine, Inc. watermakers with the durability of the Kubota 150 amp 12V diesel generators. This compact low fuel consuming AquaGen is a powerhouse, capable of producing up to 150 amps, and 8 up to 62 GPH of fresh potable water from any water source. Make fresh water, refrigeration, and also charge your batteries all at the same time! A hydraulic pump may also be added to run your dive compressor, windless, bow thruster, or emergency bilge pump. Ideal for longterm cruisers or weekend wanderers. We custom engineer our systems to fit any size vessel or cabin site. Electric, Hydraulic, or Belt Driven Modular Kits are also available. Visit our Website for more information.

QUALITY AT AFFORDABLE PRICES.
LIFETIME WARRANTY ON PUMP HEAD AND PRESSURE VESSELS.

AquaMarine, Inc., 58 Fawn Lane (P.O. Box 55) Deer Harbor, WA 98243 USA
(800)or(360) 376-3091 Fax (360) 376-3243

www.aquamarineinc.net

Southbound Solar Affordable solar solutions for sailors.

The perfect gift for your favorite sailor.

SOLAR LANTERN

\$69

Features 28 superbright LEDs 2.5-watt solar panel, AC wall charger, lithium battery & phone charger adapters.

www.SouthboundSolar.com
(503) 490-3305

CHANGES

the result of a carotid artery aneurysm. He and his wife Tami had done the '11 Ha-Ha with their CT-54 **Journey**, and had been popular members of the cruising communities in both La Paz and La Cruz. In fact, we're told Ha-Ha friends of Dick in La Paz even held a memorial service for him there.

La Paz, of course, is a popular 'next stop' for many members of the Ha-Ha fleets. Patsy Verhoeven of the La Paz-based Gulfstar 50 **Talion**, whose boat was one of only three that sailed the entire course, reports that the northers weren't as strong as predicted north of Frailes, and Los Muertos "was fabulous, as was the food at 1535, the *palapa* restaurant right on the bay."

"The arrival of many Ha-Ha boats coincided with the finish of the Baja 1000 and Mexican Independence Day, so the town was jumping," says Verhoeven, "and the net was busy with new arrivals asking for local knowledge. **The Ha-Ha Welcome To La Paz Party**, put on by the local businesses and Mexican government, was a huge success, and not just because four boats won weeklong stays



Is there a female cruiser on the West Coast more accomplished than Patsy Verhoeven? She's also pretty good at paddleboarding.

at the five-star **Costa Baja Resort and Marina**. La Paz, my town, is a fun and active place for cruisers in the winter.

There are several big events coming up on the cruiser calendar in Mexico.

December 11 is the **Riviera Nayarit Sailor's Splash**, which is a welcome to that region for Ha-Ha and other cruisers by **Paradise Village Marina** in Nuevo Vallarta, **Marina Riviera Nayarit** in La Cruz, and many other tourist businesses. The Splash is immediately followed by the three-day **Banderas Bay Blast**, which is strictly 'nothing serious' Ha-Ha-style racing for cruising boats, and also features the annual reopening of the **Punta Mita Yacht & Surf Club** and the **Pirates for Pupils Spinnaker Run for Charity**. See *'Lectronic* for details.

Farther down the calendar are **Zihua Sail Fest**, the great cruiser fundraiser in early February; **Banderas Bay Regatta**, the biggest cruiser regatta in Mexico, in March; and **Loreto Fest**, the biggest cruiser gathering in the Sea of Cortez, in early May.

In the 30+ years we've been cruising Mexico, there have been two constants: 1) The great cruisers you meet. And, 2) The fabulously warm and kind people of Mexico. Two things to keep in mind if you're considering doing next fall's **20th Annual Baja Ha-Ha**.

KATADYN SURVIVOR 35 WATERMAKER

The Survivor is a must for all sea-going vessels and is the most widely used emergency desalinator. It is used by the U.S. and international forces. It is able to produce 4.5 liters of drinkable water per hour.

Reconditioned by Katadyn **\$950**

Compare to factory new price: \$1,995

For more information or to place an order, please contact one of our sales reps.

Equipment Parts Sales

In the U.S.: (800) 417-2279

Outside the U.S.: (717) 896-9110

email: rod@equipmentpartssales.com



WIRELESS E-MAIL



SEATECH SYSTEMS™

800.444.2581 • 281.334.1174
info@sea-tech.com • www.sea-tech.com

Navigation, Communication & Weather



Quiet motor runs for nearly 8 years of continuous use.
2 speeds (0.50A, 0.25A).

Deluxe model includes 3 mounts:
Bulkhead bracket, bungee in open port, Velcro anywhere.
6-ft cord. Put the Port Fan wherever you need moving air!



HOTWIRE ENTERPRISES

www.svhotwire.com

Phone/Fax:
(727) 943-0424
hotwiregam@aol.com

"I blew most of my money on broods, booze and boats... the rest I just wasted."

— Elmore Leonard



STARBUCK CANVAS WORKS

415•332•2509

67 Liberty Ship Way, Sausalito, CA 94965

El Salvador

A hidden treasure. Share it!

  www.elsalvador.travel

El Salvador
Impressive!



Come and have a great time in
El Salvador Fourth Annual Cruisers Rally
Next March 16th to April 20th, 2013
www.elsalvadorrally.com

Please read before submitting ad

Classy CLASSIFIEDS

Here's What To Do:

Write your ad. Indicate category. Remember price and contact info. We make final placement determination.

Count the words. Anything with a space before and after counts as one word. We will spell-check, abbreviate, edit, as necessary.

Mail your ad with check or money order, deliver to our office; **OR, for the best – and most exposure – of your classified ad...**

Submit your ad safely online with Visa, MasterCard or AmEx at: **www.latitude38.com**

Ad will be posted online within two business days, appear in the next issue of the magazine, and remain online until the following issue is released.

PERSONAL ADS

1-40 Words.....\$40
41-80 Words.....\$65
81-120 Words....\$90
Photo.....\$30

• Personal Advertising Only •
No business or promo ads except Non-Profit, Job Op, Business Op

'Trying to Locate' Ads are for those searching for lost boats/people – not shopping – and cost **\$10 for 20 words max**

FREE Online Ads are for a private party selling a boat for less than \$1,000 – or gear totalling under \$1,000. (One per person; must list prices in ad.)

All ads will be set to fit *Latitude 38* standard • Re-Run Ads: Same price, same deadline

BUSINESS ADS

\$70 for 40 Words Max

• All promotional advertising •
1 boat per broker per issue
Logo OK, but no photos/reversals
No extra bold type • Max: 12 pt font
Artwork subject to editor approval.
Biz ads will not appear on website.

NEW DEADLINE

it is **ALWAYS** the **15th at 5 pm** for ad to appear in the next issue.

Due to our short lead time, deadlines are very strict and include weekends & holidays.

Sorry, but...

- No ads accepted by phone
- No ads without payments
- No billing arrangements
- No verification of receipt
- We reserve the right to refuse poor quality photos or illegible ads.

Latitude 38 15 Locust Ave, Mill Valley, CA 94941 Questions? (415) 383-8200, ext 104 • class@latitude38.com

WHAT'S IN A DEADLINE? Our Classified Deadline is now the **15th** of the month, and as always, it's still pretty much a brick wall if you want to get your ad into the magazine. But it's not so important anymore when it comes to getting exposure for your ad. With our new system, your ad gets posted to our website within a day or so of submission. Then it appears in the next issue of the magazine. So you're much better off if you submit or renew your ad early in the month. That way your ad begins to work for you immediately. There's no reason to wait for the last minute.

22-FT SANTANA, 1970. Alameda Marina, Alameda, CA. \$900/best offer. Includes main, spinnaker, 3 jibs, motor. Boat seaworthy, but needs exterior paint. (360) 666-4999 or (925) 323-2577 or ss.surbay@gmail.com.

J/24 HULL #375, 1978. Newport, OR. USA. \$7,000/obo. Good condition. Fast-fun boat, newer sails, and spares, 2 spinnakers, good standing and running rigging. Much recent hardware, many upgrades. 2-axle trailer, 3.5hp outboard. Email pmerskine@yahoo.com.

23-FT COLUMBIA "T", 1973. \$2,000. Shoal draft, roller furling, well maintained. Cockpit and interior cushions. Bilge pump, air vent fan. Ready for bottom paint. Exterior woodwork recently refinished. Dual axle trailer. Clean inside and out. Request photos. (707) 499-9396 or alpsail@gmail.com.



24-FT ISLANDER BAHAMA, 1965. Pittsburg, CA. \$3,300/obo. With 8hp Mariner outboard. Newer rigging, jib with furler, main with lazyjacks. Bottom cleaning 11/2011. VHF, fish finder, depth sounder, stereo, single-burner propane, good interior. Contact (323) 552-8224 or sanfranciscoharmony@gmail.com.



24-FT CAL, 1985. Redwood City Marina. \$4,500. Great Bay boat! Main w/single reef, Harken roller furling jib, 5hp outboard, new cushions, Porta-Potti, anchor, safety equipment and more. Call Rich at (650) 363-1390 or (650) 722-2389. Or email rich@spinnakersailing.com.



22-FT FALMOUTH CUTTER, 1979. Santa Barbara. For trade or \$45,000. Westerbeke 10 two diesel with 240 hrs, Vari-Prop. Two sets of sails - including one spinnaker and one genacker. Triple axle trailer! And much more... go to www.sailboatlistings.com/view/32262. Contact davidhornung@hotmail.com or (805) 550-7939.

25 TO 28 FEET



27-FT ANTRIM, 1999. \$40,000. High mileage. Five-time PacCup vet, E.T. is ready to go again. Always on the podium. All category 2 equipment included (call for list). Or, remove the ocean gear and go buoy racing. Contact (925) 934-5197 or tony.english@comcast.net.

26-FT CAPRI, 1993. Vallejo. \$26,000. Pristine. Fin keel, inboard diesel. Open transom, custom walk-thru dodger. Galley, enclosed marine head, holding tank and macerator. Forehatch and 5 opening ports. Two batteries w/charger. 120/12 v. systems. VHF. WS/WP, speed, depth, autopilot. Cockpit cushions, teak cockpit table. Jibs: self tacking, 115, 150, and asymmetrical spinnaker, all in perfect condition. New last 4 years: main, jib, Harken furler, standing/running rigging. New bottom paint 2012. Call (707) 252-4467.

28-FT HAWKFARM, \$8,900. Yanmar diesel. 2 mains, 7 headsails, 2 spinnakers, some recent Quantums, standing rigging/chainplates replaced 2006. KM/DS/VHF/compasses/S/T primaries, good bottom, good PHRF racer. (415) 435-6038 or (415) 924-8485.

24 FEET & UNDER



J/22, 1983. San Francisco/Monterey. \$13,000/obo. Proven winner, epoxy bottom, dry sailed since 2003, clean interior, kept dry, several sets of sails including Quantum racing set, 2003 Triad trailer great condition, lots of extras. Contact for more info/pictures. Email gggreenlee05@sbcglobal.net.

WOODRUM MARINE
Specializing in custom interior cabinetry, tables, cabinets, countertops, cabinsoles. For power or sail.

CARPENTRY
Mobile cabinet shop
Contact Lon Woodrum at:
415-420-5970
www.woodrummarine.com



NOR-CAL COMPASS
Adjustment • Sales
Authorized Compass Repair

Hal McCormack • norcal.compass@verizon.net • Phone/Fax (415) 892-7177

N.E. MARINE TITLE

Coast Guard documentation • Title/lien searches • Transfers • Mortgage filing • Escrow services
Local closing facility for brokers or private transactions
30 years experience of doing it right the first time

1150 Ballena Blvd, Alameda, CA • (510) 521-4925



MARINE SURVEYS - Capt. Alan Hugenot

Accredited Marine Surveyor (since 2004) • (415) 531-6172
Yacht Master (USCG 200 tons - International) • Port Engineer
Yacht Manager • Delivery Skipper • Boat Handling, Navigation & Safety Instructor • Accepts MC & VISA

25-FT MERIT, 1986. Morgan Hill. \$8,900 or trailerable trade. New gelcoat, new lifelines, low hour Honda 2hp. 1999 tandem Trailrite trailer, just added 5 support posts and pads (11) total no rust. New, never hoisted UK Kevlar jib. Other sails fair. Custom foam cockpit cushions. (408) 842-6511.



27-FT MORGAN, 1972. Alameda, Ballena Isle Marina. \$7,500. Maintained and used for day sailing in Bay Area. Excellent for day use and coastal cruising. Engine: Yanmar diesel 1GM1 8hp. Runs great. Bottom and side painted June 2011. <http://sfbay.craigslist.org/eby/boa/3352188924.html>. (415) 238-0046 or dgililov@hotmail.com.

27-FT DUFOUR, 1974. Emery Cove Marina. \$10,000. Good condition. Sails are two years old, roller furling jib, Volvo Penta 20hp, variable pitch prop. Contact (510) 672-1729 or (510) 965-1614 or raphael_julie@yahoo.com.

25-FT CATALINA, 1984. Berkeley. First serious offer. Everything in good shape. New upholstery, 5 foresails. Whisker pole. 6hp Nissan O/B. Very clean and ready for sailing. Contact (510) 984-4685 or kernull@yahoo.com.

29 TO 31 FEET

30-FT RAWSON, 1964. San Rafael. \$7,900/obo. *Blue Moon*. 100 hour Yanmar 3-cyl 30hp diesel. Radar, GPS, 12-ft Livingston tender, VHF, hot water, fully found, 6-tonner, 6'4" headroom. Lying San Rafael liveaboard berth. Call or email for more info. (562) 899-0774 or sswells@att.net.

29-FT ERICSON, 1975. \$6,500. Unique 1975 Ericson 29, USCG documented, lying Napa Valley Marina dry store. Hull and deck in good shape, LPU mast and boom; mast rewired this year. 1 season on new Pineapple main, 120, spinnaker. Unused storm jib, older genoa. Newer standing rig. Custom canvas and 36" wheel. Strong rebuilt Yanmar YSB12. Pressure water, stove, custom joinery inside. Loads of gear and extras. 22 years one owner. Needs interior cushions and minor electrical and mechanical work, but a great Bay or coastal boat. Email e29forsale@gmail.com.



29-FT COLUMBIA, 1964. Alameda. \$4,500. Hull 103, LOA 28'6". Re-powered with Yanmar 3-cylinder diesel, 27.3hp, 177 hours. Interior in very good condition, outside solid, but needs cosmetic work. Larson full-batten main with Dutchman flaking, Schaefer furler with 95% jib. (831) 277-6034.

30-FT WYLIECAT, 1996. \$75,000. #3, *Silkye*. 5hp outboard. Faux-finished carbon mast. Carbon rudder shaft, upgraded wishbone, spinnaker, Autohelm, re-done nonskid and bottom. A rare chance to own one of these fast, stable, easy-to-sail boats. (510) 521-7730.

30-FT BODEGA, 1977. Redwood City. \$6,000/obo. Marina closing - unique opportunity to obtain partially completed sailboat. Clean Volvo diesel. Mast stepped. Teak cockpit. Bulkheads in place. Corian galley, cold-plate refrigeration. Teak V-berth with plywood quarterberth, chart table, settees. <http://home.jps.net/~tbishop/>. Contact (650) 283-0555 or tbishop@jps.net.



30-FT BRISTOL CHANNEL CUTTER. 1997. \$125,000/obo. 30-ft Lyle Hess Bristol Channel Cutter, *Tigress*, 1997, sistership to the Pardey's famous *Taliesin*. Extraordinary craftsmanship. Mahogany on oak. Teak cabin and decks. Hull so fair many think it's fiberglass. Amazing teak and birdseye maple interior. 27hp Yanmar. Well equipped: roller furling, storm trysail, spinnaker, sea anchor, radar, chartplotter, autopilot, windvane, refrigeration, VHF, 110V electrical, inverter, Force10 heater, Force10 stove/oven, windlass, 9-ft Fatty Knees dinghy with sailing kit, much more. Pristine like-new condition. More at www.tigress-bcc.com or call (650) 868-0348.

30-FT HUNTER, 2002. Hidden Harbor. \$39,500. Beautiful boat. Professionally maintained and ready to go. Yanmar diesel. Roller furling. All lines led aft. Comfortable cabin. VHF. CD stereo. Propane galley. Fun to sail. Email for pictures: calvertvet@exwire.com. Call (530) 389-8387 or (530) 346-2266.

30-FT CAL 3-30, 1974. Napa Valley Marina Dry Storage. \$5,000. Best fixer ever! Needs electrical work, fuel pump and interior varnish, but ready to sail. Large sail inventory. Very sturdy, stable boat. See website for info and photos. <http://dumpyoldbroad.blogspot.com>. Contact rebecanham@earthlink.net or (707) 746-5076.

J/29, 1984. Redwood City Marina. \$10,000. Main, almost new Pineapple #3 and #2 jibs, 3/4 oz. spinnaker. New 8hp 4-stroke outboard, anchor, safety equipment. 2011 SYC race series winner. Call Rich at (650) 363-1390 or (650) 722-2389. Or email rich@spinnakersailing.com.



30-FT NEWPORT, 1978. Alameda. \$9,500/obo. Ready to motor, sail, or live aboard. Recently overhauled Yanmar diesel. Propane oven. Pineapple jib on Harken roller furler, main and asymmetric spinnaker with whisker pole. Immaculately clean, bright cabin. Topsides need attention. Contact (510) 406-2399 or briss1935@gmail.com.

30-FT ETCHELLS 22, 1978. Brickyard Cove. \$4,000. Driscoll hull #448, built '78. Complete with two sets of main, jib, spinnaker in great condition. With a trailer. Regularly sailed. This is being sold so that I can get a cruising boat satisfactory for my spouse. Asking only \$4,000/obo, which is less than the value of the sails. This is the most exciting sailing for this price. At Brickyard Cove, Point Richmond, CA. (415) 599-5792 or tedw37@gmail.com.



29-FT RANGER, 1973. Fortman Marina, Alameda. \$13,000/reasonable offer. All lines to cockpit. Singlehanded Transpac vet. Yanmar 2GM20F, good sails, TP, new electronics, self-tacking jib. Details at web site: <http://sites.google.com/site/ranger-29joy/>. Contact (831) 345-9384 or (831) 726-3192 or lewiskeizer@gmail.com.



NEWPORT 30 MK III, 1982. Sausalito. \$16,800. Fast and comfortable; points well, 2006 Doyle main, 3 jibs, 2 spinnakers. Beautiful teak interior. Dependable diesel engine. Roller furling. Spinnakers. All lines led aft for singlehanded. Sweet boat. Contact (415) 225-7736 or Danfron@aol.com.



30-FT RAWSON SLOOP, 1964. Ballena Isle Marina, Alameda. \$18,500. Beautifully restored Rawson 30 sloop. Tanbark sails, bronze ports and hardware, 4-107 diesel, radar, AIS, chartplotter, high amp alternator, Monitor windvane and much, much more. See more at website: <http://restoredrawson30.blogspot.com/>. (408) 234-5359 or carlbabb@mail.com.

32 TO 35 FEET

34-FT CATALINA, 1987. Alameda. \$48,000. Mexico vet. Electric windlass, 3 anchors, solar panels, wind generator, SSB radio with Pactor modem, radar, 2 GPS chartplotters, autopilot, high aspect rudder, 2 fuel tanks, Spectra watermaker. Dodger, bimini, dinghy motor hoist, fishing gear. 100 amp alternator, PSS shaft seal. (209) 295-2566.

32-FT ERICSON, 1984. Sausalito. \$12,000. Diesel, roller furling, wheel steering. Contact (415) 331-8250 or jack@modernsailing.com.

33-FT CAL, 1972. San Carlos, Sonora. \$15,000. *Carlota* was repowered with Universal 4 diesel. Has dinghy, 8hp outboard, SSB, Autohelm, radar, and lots of cruising equipment and spares. Also includes a new helical mooring in San Carlos Bay. Contact (520) 284-0806 or k1bgd@yahoo.com.

33-FT RANGER, 1976. Berkeley Marina. \$15,000. New topsides, racing bottom, racing equipped, interior spartan, but cruising gear included in sale. Excellent racing record, rebuilt Atomic 4, 3 kites, 3 headsails, very fast, retiring from racing. (510) 548-1210 ext.12 or (510) 652-3969 or myy@yovino.com.

RIGGING ONLY ◊ SMALL AD, SMALL PRICES

Standing and running rigging, life lines, furling gear, winches, line, windlasses, travelers, wire and terminals, blocks, vangs, and much more.

~ Problem solving and discount mail order since 1984 ~

www.riggingonly.com • (508) 992-0434 • sail@riggingonly.com



Get the Reliable, Powerful Wheel Pilot

Quiet & Dependable • Affordable • Built for Immersion
Easy Owner Installation • Low Power Consumption

831-687-0541

www.cptautopilot.com



STARBOARD YACHT DELIVERIES

Over 50,000 sea miles • Pacific, Caribbean, Atlantic
USCG Master 100 GT STCW • Power & Sail

Rick Whiting • (415) 740-2924 • captain_rick@sbcglobal.net



Spaulding Wooden Boat Center

Youth Boatbuilding Program • Community Sails
Boatworks since 1956 • We Specialize in Wooden Boats
Become a Member! 501(c)(3)

www.spauldingcenter.org • (415) 332-3179

33-FT SPAULDING, 1964. \$25,000. *Auroral*, Spaulding 33 fractionally-rigged sloop, built in 1969. Made of finest materials. Spruce mast, boom and spinnaker pole. Restored bottom and rudder 2010. Sleeping berths for 4 people. Gray Marine engine. Hood sails and more. Email jonah_ward@hotmail.com.

34-FT EXPRESS, 1988. RYC. \$59,750. *Two Scoops*, well maintained, well sailed, fast with great sail inventory. Equipped with stove, refrigerator, GPS, radar, VHF with cockpit and nav station locations and marine AM/FM stereo. Contact (415) 450-1113 or (415) 383-1006 or c_longaker@sbcglobal.net.



35-FT YOUNG SUN CUTTER, 1981. San Carlos, Mexico. \$54,800. Proven blue water cruiser, ready to sail the world, with a bombproof fiberglass hull. Fully cruise equipped, designed by Robert Perry, same layout as *Tayana 37*, but at a bargain price. <http://youngsun.squarespace.com/specs>. Email mohrmonite@gmail.com.

ERICSON 35 MK II, 1977. Richmond YC. \$39,000. Bruce King design. Loved and well maintained. Equipped for cruising. Sleeps 5. The years have caught up to us, must sell! Detailed info and photos on website: www.ericson351977.blogspot.com. Contact (925) 935-4413 or sqsailors@hotmail.com.



35-FT IRWIN CITATION 35.5, 1986. Marina Bay Yacht Harbor. \$29,000. Great handling racer/cruiser with stylish lines in excellent condition. Nice teak interior sleeps 7. Memory foam cushions in V-berth. Nice galley with ice box, double sink and 2-burner propane stove. HD TV and Dolby 5.1 sound system. AC water heater, low hours Yanmar 3GM30F diesel, roller furling jib, Barlow 25 winches, Garmin GPSmap 178. New battened mainsail Oct. 2011. A lot of solid boat for this price! Contact (530) 863-9607 or heartnsprit@hotmail.com.

31-FT PACIFIC SEACRAFT (35 LOA), 2004. Dana Point. \$139,900. Excellent condition, cruise ready, cutter, Monitor vane, 130 W solar, two autopilots, dodger/bimini, heater/fireplace, cold plate refrigeration, liferaft, EPIRB, radar/plotter, depth, VHF, spare parts. (949) 285-8362 or pvanenwy@csub.edu.

36 TO 39 FEET



37-FT CREALOCK, 1997. La Paz, Mexico. \$187,000. Excellent condition and location. She's totally turn-key and ready for your big cruise or commuter cruising Mexico. Hawaii and Mexico vet. Singlehander's package, shoal draft, Monitor windvane, liferaft, EPIRB, SSB, radar. Custom storage in galley and head, manuals, tools, spares, spares and spares. Dinghy with wheels and outboard. 2011: new lifelines, running and some standing rigging, full-batten main with Tides marine track, interior cushions and fabric. 35# CQR and 44# Delta on bow, 25# on stern. Dinghy w/wheels and outboard, Kato engine lift. (310) 459-1510 or JimmyP0201@gmail.com.

38-FT BENETEAU, 1991. Sausalito. \$32,000. Diesel, roller furling, beautiful sailing boat. This is a great year and a very good design for this classic looking boat. Contact (415) 331-8250 or jack@modernsailing.com.

37-FT CREALOCK, 1979. Monterey. \$50,000. Cruising consultants, new LPU entire prop, new interior, new Yanmar. Email for pics and video. (831) 234-4892 or dcd987@gmail.com.

36-FT PEARSON, 1985. Sausalito. \$45,000. Priced to sell. Owned for 15 years and am 2nd owner. Equipment: Roller furling jib, Dutchman system on main, Forespar rigid vang, 3-blade feathering prop, dodger, Lifesling, life jackets, BBQ, complete kitchen setup, more. Original Yanmar diesel with only 385 hours. Original purchase receipt, owner's manual, sail plans, etc. Hauled, painted Oct '10 along with new cutlass bearing. Beautiful interior in near-new condition. Insurance survey in Feb '11 valued at \$70,000. Great boat at a great price. Located at Schoonmaker Point Marina, slip C-72. www.flickr.com/photos/rgt-pics. Contact Bobgthomas@EarthLink.net or (925) 286-8738.

36-FT HANS CHRISTIAN, 1975. Oyster Point Marina. \$35,000. Proven cruiser from Alaska to New Zealand. *Good Bones*, needs new sails and little TLC to restore her to offshore condition. Monitor windvane, dinghy and more. USCG documented. Contact (415) 337-5303 or svtekin@gmail.com.

37-FT RANGER, 1978. San Pedro, CA. \$16,500. **SOLD** Some work to be done. 30 hp diesel, 12' inflatable dinghy.

40 TO 50 FEET



42-FT CASCADE, 1972. Redwood City. \$40,000. New sails, watermaker, Autohelm, new rigging, ice maker, marinated Westerbeke and more. Needs work on deck. Spent a lot, asking for less. Contact (650) 704-2302 or galaxaura@gmail.com. PO Box 3163.



41-FT MORGAN OUT ISLAND, 1981. Glen Cove, Benicia. \$47,500/obo. Center cockpit, 416 ketch rig. Great coastal/ocean cruiser. Shoal draft boat designed for chartering in Caribbean. Spacious layout down below, separate forward cabin w/head/shower and hanging locker. Ultrasuede cushions, updated lighting, Dickinson diesel heater. Refrigeration/freezer, three-burner propane stove/oven, microwave. Full walk-thru to master stateroom w/head/shower and separate cockpit entrance. Surprising amount of storage/stowage for a 41-ft vessel. Newer sailcovers and dodger. Rigid boom vang. Great Perkins 4-154 engine. Dinghy davits off transom. Amazing cruising yacht, in great condition at a bargain price. Our plans have changed, so add your custom electronics and go on your own adventure! Call Ken. (415) 269-2971.



43-FT SPINDRIFT CENTER COCKPIT, 1980. Pago Pago, American Samoa. \$130,000. Rugged double-ender, full keel, 80hp Lehman-Ford, large tanks, autopilot, radar, 2 SSB's, VHF/AIS, triple-reef main (new), Profurl jib, hanked-on staysail, nine 2-speed self-tailing winches. EPIRB, liferaft (new), two dinghies, two outboards, 2kw Honda generator, watermaker, 4-burner stove, freezer, two heads, electric windlass, 60-lb CQR, 300' chain, cockpit enclosure; 6'-10" headroom below. Extensive features. One-owner boat since new. Cruised S. Cal to Mexico, Hawaii, BC, Central America, Panama, Galapagos, Pacific islands Marquesas, Tahiti, Cooks, Samoas, Tonga, Fiji, Vanuatu, and NZ. After 13 years Pacific cruising, owner (age 80, recently widowed) says that's it! Boat ideal for experienced couple wanting larger boat. Pago good start point for SW Pacific cruising. (684) 252-3489 or nashsail@aol.com.

41-FT MORGAN CLASSIC MODEL, 1991. San Carlos, Mexico. \$93,000. Cruiser, in primo condition, ready to go. Spacious interior - must see to appreciate. Recent survey. Use link for current photos, complete equipment list: <http://sailboatvagari.blogspot.com>. (520) 825-7551 or stanstrebig@gmail.com.



48-FT BENETEAU 47.7, 2003. Sausalito, CA. \$275,000. Bruce Farr design with tall mast and deep keel performance hull. 3 staterooms 2 heads, 1 electric. 75hp turbo Yanmar with 265 hrs. 3-blade feathering prop. Bow thruster. Electric mainsail winch. Dutchman mainsail flaking and Furler headsail furling. Furuno radar on self-leveling Questus mount. B&G instruments including autopilot with remote at helm. Icom 502 VHF with remote and Icom 802 SSB. Espar heat. Xantrex 2500 watt inverter with Prosine Advanced Digital Control. ProMariner galvanic isolator. Original owner. Maintained as new. (916) 969-8077 or curtis@surewest.net.

NOR'SEA 37

Designed by Lyle Hess Built by Michael Hess of Hess Marine
Big Sister to the NOR'SEA 27

Stout Offshore World Cruiser Cutter Rig Canoe Stern
WWW.NORSEA37.COM • (855) 460-4455

MOBILE MARINE PUMP-OUT SERVICE

\$25 per pump up to 40 gallons.

Includes fresh water flush and a packet of treatment.
20% discount for regularly scheduled service.

www.mobilepumpout.com • (415) 465-0149 • tim@mobilepumpout.com

Offshore Sail & Learn Expeditions

Panama-Florida-Bermuda-Azores-Spain

www.arseizavelsailing.com

Remember Your Crew This Sailing Season...

Give the gift of *Latitude 38* Logowear

See our chandlery at: www.latitude38.com



44-FT CATALINA MORGAN, 2007. Seattle, WA area. \$284,500. Mint condition. A real deck salon. Great bluewater cruiser. 75hp Yanmar 8+ cruising, 500 hours. New batteries, cruising spinnaker, power winches, hydronic heat, Raymarine C120, radar, autopilot, bow thruster. Will trade for real estate. (408) 666-3261 or jerryfsaia@aol.com.



CAL 2-46, 1974. Point Roberts. \$95,900. Reduced.. Ready to cross oceans. Lovingly maintained and restored. 2012: Engine overhauled, standing rigging, furler, hydrovane, sails. Also electric winches, davits, watermaker, spares! Standup engine room, teak/holly sole, much more! <http://merrydolphins.xq.net>. Contact nelson2bed@gmail.com or (250) 505-4941.



50-FT FD-12, 1981. Sea of Cortez. Unsinkable fully equipped blue water cruiser, AK/Mex/SoPac vet. Superb galley in pilothouse. 2 staterooms fwd and master stateroom aft w/berths for 5-6 and great fore/aft privacy. Reduced price. See website for details: www.svdaydreamer.com.



44-FT TARTAN 4400, 2003. Channel Island Harbor. \$399,000, or trade? Reduced price! Dark green hull, low hours, bow thruster, electric winches, vacuflush heads, spinnaker, new batteries, new LP and bottom paint, numerous other options/upgrades. See test sail at: www.youtube.com/watch?v=ckZHxXEAMec. Contact amjohn@sbcglobal.net or (530) 318-0730.



40-FT SANTA CRUZ, 1983. Monterey. \$87,000. A fast racer/cruiser. Excellent condition. Extensively updated. New Ballenger spar and rod rigging. Re-wired. New Raymarine instruments, windlass, inverter, refrigeration/freezer. New gelcoat decks and topside paint. New dodger. Custom transom ports. For photos and info see website: <http://santacruz40for-sale.com>. Contact (831) 915-3540 or jimbo@mbay.net.



40-FT PEARSON BOUNTY II, 1961. Brisbane Marina. \$28,500. Early bulletproof fiberglass. Sailed from Hawaii. Loaded. Sloop rig, Harken roller furling. 5 sails in great condition. Yanmar 27hp 3GM30F diesel engine, 75 watt solar panel, Ampair 100 wind generator, 4 AGM batteries, Prosigne Truewave 1000 inverter, Monitor self-steering windvane, Icom IC-M700 Pro with Pactor III modem, Dynaplate, backstay antenna, Apelco VHF, propane Force 10 stove, Waterlog watermaker, Interphase depth-finder, lots of extras. This boat is a steal at \$28,500. (510) 410-5401.



45-FT GARDEN YAWL. One off, double end, 3 years in restoration, 98% completed, cold-molded over original strip planked, new electric motor. \$60K as is, or \$? to finish. Contact (916) 847-9064 or stevebarber046@mac.com.



41-FT SCEPTRE, 1986. Crescent Beach, B.C. \$168,000. Original owners. Professionally maintained. Recent survey and bottom paint. Call or email for more info and pictures. (604) 535-9373 or raceaway@shaw.ca.



43-FT TASWELL, 1988. Alameda, CA. \$239,000. Bluewater cruiser. Major refit in 2007, then cruise perfected. Full details at website, listing: 1291827. Contact Steve. www.yachtsoffered.com. (530) 748-8010 or lotus48@att.net.



46-FT JEANNEAU SUN ODYSSEY 45.2. 2000. Tacoma, WA. \$134,000. This salt water veteran is fully equipped with all the necessary equipment to take you offshore in the direction of your dreams! She just got back from a cruise in the Med and the Caribbean and is lying Tacoma, WA waiting for you to prep her for her next voyage. She is a rare 3 cabin/3 head model, perfect for a family or larger group cruising - each cabin has its own head. Great charter opportunity for America's Cup next year! The vessel has many upgrades - and lots of spares! (206) 992-6637.

47-FT CATALINA, \$285,000. Customized bluewater ready. Extra fuel capacity, 110 or 240v, watermaker, chartplotter, radar, AIS, coldplate fridge/freezer. Custom cabinets and workshop, dive compressor, in-boom furler, staysail, autopilot, wind vane, new hard dodger, heat-air, Autoprop, Much more. (916) 607-9026 or cestlavie_2000@hotmail.com.

43-FT HANS CHRISTIAN CHRISTINA. 1986. Redwood City. \$179,000. Volvo TMD 30A 90hp. Furuno 1720 radar. Balmar 1200 windlass. Harken furling on jib and staysail. Barient winches. B&G 330 instrumentation. Newmar PHD-25 battery charger. Raritan 12-gallon hot water heater. Packless Sealing System (Svendsen's). Very roomy and comfortable 3-cabin layout (pullman master). VacuFlush/Tank Watch 4 monitoring system. Beautiful new granite countertops in galley with flowing colors to match the tongue-and-groove teak throughout. Norcold refrigeration. Force 10, 3-burner propane stove. Alpenglow lighting. All new enclosed dodger/cockpit (watertight) with covers and privacy screening for all windows... only the finest materials used. (650) 207-2253 or ps4010@aol.com.

44-FT HARDIN VOYAGER, 1977. Marina Palmira, La Paz, BCS, Mexico. \$79,000. A spacious fiberglass, ketch rigged veteran of the Sea of Cortez and west coast of Mexico. A traditional liveaboard and long range blue water cruiser with rare two-cabin, two-head layout. Center cockpit with hard dodger. Recently recalculated teak decks. Aft cabin has transom windows above the thwartships queen size bunk and opening portholes for ventilation. Go to YachtWorld.com for specs. (530) 541-4654 or mortmeiers@aol.com.

42-FT CATALINA, 1990. South Beach Harbor, San Francisco. \$89,900. Great condition. Extensive upgrades. Full spec at: <http://leluya.blogspot.com>. (650) 716-4548 or leluya123@gmail.com.



41-FT NEWPORT, 1984. Bruno's Island Marina. \$49,000. Price reduced. Mexico vet, radar, GPS, autopilot, 40hp Universal diesel, solid rod rigging, 38 gal. fuel, 60 gal. water, sleeps 6, 8-ft dinghy with 9.9hp Nissan. (707) 688-0814 or (707) 290-9535 or raaddink@yahoo.com. 1200 Brannan Island Rd.

40-FT OLSON, 1983. Squamish, B.C.. \$73,000. Race and cruise equipped, Pac Cup ready, Espar furnace, fridge, dodger, furler, etc. An extensive equipment and sail list. (604) 898-9484 or (778) 879-4272 or jgugins@telus.net.

50-FT MARINER MOTORSAILER, 1980. Redwood City. \$165,000. Great liveaboard cruising boat. 2 staterooms, 2 heads, 300 gals fresh water, 400 gal/day watermaker, upright frig/freezer, separate deep freeze. Too much other equipment to list. Please contact for complete list. (831) 335-3573 or ladyhawke50ft@yahoo.com.



MARINE SURVEYOR

Sharpe Surveying & Consulting. SAMS Accredited Marine Surveyor. Serving the San Francisco Bay and Delta.

RSharpe@SharpeSurveying.com • (510) 337-0706

'lectronic Latitude

Just like the magazine but... online, three times a week, and totally different! Find it at www.latitude38.com!



PROFESSIONAL DELIVERY CAPTAINS

San Diego based, USCG Master 100 GT. Sail and power. ASA-certified instructional deliveries. Pacific Mexico and Baja Bash specialists. **davidbrotherton@yahoo.com • www.boatdeliverycaptain.org • (619) 913-7834 •**



Afterguard Sailing Academy

The Affordable Way to ASA

ASA Basics to Ocean • Crew Intro to Cruising Prep
(510) 535-1954 • www.afterguard.net

46-FT JEANNEAU SLOOP, 1996. Puget Sound, WA. \$149,900/offer. Good condition, newer North sails, newer Raymarine C-80 chartplotter, radar, Autohelm, Tri-data speed/depth, etc. Very clean below. 3-cabin, 2-head layout, inline galley, fridge/freezer, navigation station, AC, more. Contact (253) 377-1660 or sailingfans@hotmail.com.



43-FT SERENDIPITY, 1980. Best offer. *Lone Star*. Doug Peterson's SORC Serendipity 43. A winning combination: great performance and gracious living. The perfect cruiser. Must sell now. Email for brochure (specifications and current photos): svlonestar@yahoo.com.



45-FT COLUMBIA, 1971. Redwood City, CA. \$47,000/obo. World cruiser. Huge liveaboard. New radar and GPS. 2 steering stations. 55hp diesel. Separate shower. 2 heads. 2 staterooms. Large main salon and galley. Email for list of equipment, photos, and viewing: boomkin65@yahoo.com.



44-FT KELLY PETERSON, 1977. Daytona Beach, FL. \$95,000. Well maintained/new rigging/mast pulled, relit, repainted like new. Good access to Perkins 4326 diesel rebuilt 2009. New stainless steel diesel and water tanks. Diving equipment, great galley, sleeps 7. New electronics, inverter/charger, Navtex, Raymarine radar, Icom SSB, West Marine VHF. Fully battened main, 110 genoa, new storm sail, beautiful spinnaker. Lots of tools/equipment and parts. Sails like a dream! Left Alameda 14 yrs. ago. More at www.grace44.com. Contact (702) 767-8323 or (702) 767-8322 or jkjng38701@aol.com.

J/120, 2001. San Francisco. \$180,000. Great one design boat for the Bay. Extensive inventory. Full B&G instrumentation, GPS, Yanmar with low hours. Kevlar and carbon racing sails. Recent haulout 2012. Excellent condition. Contact (650) 363-1390 or (650) 722-2389 or rich@spinnakersailing.com.

51 FEET & OVER



53-FT ISLANDER, 1979. Sausalito. \$66,000/asking. Monitor, radar, rewired, new fuel tanks and extensive equipment. Sale by owner. <http://polaris5.weebly.com>. (415) 332-6585.



73-FT AMERICA'S CUP SLOOP, 1992. Sausalito. \$143,000. Carbon composite hull, rigged for cruising, galley, 100hp Volvo diesel, Harken mainsail track, furler, aluminum spar, radar, VHF, solar, wind turbine, inverter, 2 jibs, 2 used mainsails, built by USSR. Fast and unique. (206) 715-8423 or tyone@rocketmail.com.



51-FT STEEL KETCH. Super world cruiser, Ventura. \$89,900/reduced. 51' overall, 44' on deck. Ford Lehman 80hp diesel engine with low hours. Radar, AP, dodger, inverter, furling jib and genoa, custom exterior paint, with an elegant mahogany interior are just a few of her great features. This is a stout, well-built offshore cruiser. Has a draft of less than six feet and 250 gallons of fresh water capacity. Built in Holland by the best steel boat yard in the world. Owner financing available up to 80%. Also willing to consider equity trade for real estate. Quit your job start your life today with *Felicity*. Replacement cost exceeds 1 million dollars. Call (805) 982-0684 (cell), (805) 650-8888 (office) or (805) 290-6119. Email dennis@survivalsystems.com.

59-FT SAMPSON, 2011. Newport Beach, CA. Nearly completed, bluewater cruising, Sampson ketch, ferrocement full keel. 47-ft deck, 58-ft LOA. Center cockpit, full mahogany interior, three staterooms, two heads, interior/exterior steering. Call Rod for video/inventory list. (714) 963-9282.

CLASSIC BOATS



32-FT DOUBLE ENDER TEHANI, 1926. Sausalito. \$30,000. Classic Danish yacht in beautiful shape. Regularly sailed and always maintained. Email me for pictures/info: pgaetani@gmail.com, or call (415) 246-7712.



58-FT SCHOONER, 1925. Port Townsend. \$139,000. *Suva* is a staysail schooner designed by Ted Geary. A gorgeous and sound classic yacht built almost entirely of Burmese teak. LOD 58', beam 14', draft 6'6". With dual station steering she is comfortable. Her rig is easily handled and she sails wonderfully. She is in very good condition. More at website: www.schoonerforsale.com. Contact (360) 643-3840 or schoonersuva@gmail.com.



15-FT SNIPE, 1950. Albany, CA. \$1,800. Gorgeous 15-ft Snipe sailboat and trailer. Original owners, Mahogany clear deck, aluminum and wood masts, sails, etc. Boat has always been garaged and looks like new. Contact John at (510) 468-0380 or john.serex@colliers.com.



MULTIHULLS



35-FT CROWTHER BUCCANEER. 1987. Richmond. \$32,000. Ply and epoxy professionally built trimaran. Larger and dryer than an F-31 for 1/3 the price. Sails 12 knots easily, will push 20 in a breeze. New paint: 3 bottom coats, topsides and deck. Buy now and get to know *Jabberwock* by SSS Three Bridge Fiasco. Email phillip050@yahoo.com.

48-FT LOOPING, 2004. Loreto, Sea of Cortez, Mexico. \$399,000 USD. Spacious, luxurious, clean French-built performance catamaran ready to take you cruising. Fully equipped, pristine condition. MUST SEE!! Tour us on YouTube: Uj33dCr9FnY. Details on website: <http://neofsorsale.com>. (916) 622-9348 or lloyds@jps.net.



42-FT LAGOON 420 CATAMARAN. 2008. Belize. \$298,000. Loaded 3-cabin owner's version. Well maintained. Factory dual diesel, generator, AC, watermaker, inverter, chart plotter, new sails one year. Perfect family cruising cat. www.facebook.com/media/set/?set=a.219422708070841.63102.149453491734430. Email soteljohn@hotmail.com.



38-FT CHAMBERLIN CAT, 1992. Nevis St Kitts, Caribbean. \$85,000. Custom composite Vac-bagged Divinycell/Vinyl Ester/Biax racer/cruiser. 2 doubles, 1 head, galley up, bridgedeck with seated headroom (4'6", 5'9" in hulls). Queensland-built, 20,000 ocean miles. Must sell. Email sydeva@gmail.com.

★ ★ ★ ★ ★
STARPATH Online Courses
 in Navigation and Weather
www.starpath.com 800-955-8328

★ **NEW CLASSY DEADLINE...** ★
Starting NOW, the New Deadline is ALWAYS the 15th of the Month.
 Submit online at: www.latitude38.com

DOGGIEVENTURE – A doggie daycare on the go!
 Morning, mid-day or afternoon sessions available in San Francisco
Training • Boarding
www.doggieventure.com • (415) 314-7541

YOGA FOR SAILORS ON THE SAN RAFAEL WATERFRONT
 Perfect for beginners and those seeking to balance strenuous activity with gentle stretching, rest and recovery.
 Small group classes Tues/Thurs and private sessions.
 (415) 785-4530, www.bowyoga.com

34-FT GEMINI 105MC, 2005. Redwood City, CA. \$129,900. Great family or race boat. Perfect for San Francisco Bay, coast, Mexico, beyond. Fast; easy to sail singlehanded without heeling. Spacious deck, 3-bedroom interior. Elegant and comfortable. See more at website. <http://loonasea.gibbons.web.stanford.edu>. Contact loon.asea@yahoo.com or (650) 380-3343.



55-FT MALCOLM TENNANT, 2006. Ft. Myers, Florida. \$895,000. Maximum speed 17kts, cruise 15kts, 2.5gph at 8kts. Fast and economical Open roomy design with 6' 11" interior, 3 queen size cabins with individual heads and showers. Superb condition. Request complete information. Email viclips@hotmail.com.



30-FT GEMINI 3000, 1984. Puerto Escondido, Mexico \$45,000. Hull repairs being completed. Need steering cables and 9.9 Honda repairs. Not cosmetic gem, but self-sufficient/functional, 3 cabins with queen, solar, 8 amp hour/day refrigerator, chartplotter, autopilot, watermaker, well equipped. Contact ssnick@gmail.com or (510) 846-6417.

POWER & HOUSEBOATS



62-FT HOUSEBOAT. Sausalito. \$35,000. Houseboat 22x62, on 20x55 concrete barge. Absolutely no berth, must be removed from Marin County. Copper roof, V-joint Redwood siding. You can re-hab what is there, or demo and start from the barge up. A new concrete barge this size would cost \$84,700. (415) 465-0039.

50-FT BLAINE SEALY, 1978. San Leandro Marina. \$37,000. 50-ft spacious, liveaboard trawler in San Leandro Marina. Large living room, full kitchen, 2 staterooms, 2 baths, excellent running diesel, 4 levels with fly bridge, lots of teak. Two refrigerators, one freezer, washer and dryer. Great liveaboard with an excellent view and location. Call if you are serious. (415) 503-7192.

78-FT DESCO TRAWLER, 1963. Emeryville. Entertaining offers. Beautiful classic yacht operating as a floating B&B, event and concert venue. Great revenue. 5 staterooms, 4-1/2 baths, amazing woodwork, hot tub, views, ambiance, more. Owner financing possible. See www.barkissimo.com. Call for appointment, (415) 265-9706.



42-FT TRAWLER, 1979. Long Beach. \$79,000. 42-ft California LRC twin 3208's. This boat is in really good shape. I would also trade for a motor sailer or remote cabin of equal value. The slip can come with the boat. It has a great view and is a great place to live. I will email pictures upon request. Contact (310) 418-0379 or Wbnfnrench@msn.com.

43-FT VIKING MOTORYACHT, 1978. Sausalito. \$75,000. Viking is well known for their quality engineering and rugged construction. This vessel is equipped with twin Detroit diesel 6-71's, Onan 7.5Kw generator, new main fuel tanks, new canvas flybridge enclosure, dripless seals, cutlass bearings, new heavy duty AGM 8D batteries, master stateroom Queen walkaround, Vacu-flush head system with Tankwatch monitor. She has been well taken care of with light use. (650) 400-9813.



39-FT C&L EUROPA TRAWLER, 1980. Moss Landing, CA. \$49,500. Twin Ford diesels. Berthed at Moss Landing, North Harbor (assumable slip). Great spot to relax. Clean with lots of extras. (831) 713-6719.

PARTNERSHIPS

CATALINA 380, 2001. Sausalito Yacht Harbor. Full electronics, chartplotter, autopilot, and radar. New furling main and jib (2011), Quantum cruising chute, Yanmar 40 with low hours, dodger, electric windlass. Professionally maintained. Equipped for sailing and cruising: 2 cabins, centerline berths, innerspring mattresses, refrigerator, microwave, flat screen HDTV/DVD, electric head, and separate shower. Includes dinghy and outboard. Beautifully finished interior in Ultraleather and Corian. Equity share available, as low as \$335/month, depending on usage. (707) 421-0366 or CSMSam@aol.com.



CATALINA 38, 1984. Sparkman-Stephens. Emery Cove Yacht Harbor. \$10,000, plus... +\$250 a month for a week's use. Beautiful, well-maintained vessel. Perfect for weekend at Angel Island, San Francisco, Napa or the Delta. Recently hauled. New upholstery. Custom teak salon and cockpit tables. "Toys" include: fold up bicycles, dinghy with Honda outboard, 32" flat screen, auxillary generator, pulpit seats and refrigerator. Spinnaker. Purchase is like a timeshare... deposit, monthly use, monthly fee, no maintenance, you could sell your interest. Email 1derful@comcast.net.



SOUTH OF THE BORDER



COME JOIN US FOR A WEEK. Take a vacation! Learn or share your sailing skills with a USCG captain. This season we are sailing the Sea of Cortez to Acapulco. Join us, or form a group up to 6 of your friends and have the whole boat - a 52' ketch with the finest amenities. Includes, food, fuel, slip fees, scuba gear and tank fills. Great food, good friends, and adventure. See website for all the info: www.freya52.com. Email freya52@live.com.

COZY, SAFE LAND BASE. San Carlos, Sonora. \$37,900. A comfortable and affordable land base on the Sea of Cortez. Included: small casita, 32' trailer, large, covered outside living space w/kitchen. Established community, pool, spa 24/7 security and more. (530) 545-2159 or dixiemtn@sbcglobal.net.



PLAN YOUR MEXICO GETAWAY NOW. at the brand-new, gorgeous Cielo Y Mar condos. Located in Punta Mita, 35 minutes from Puerto Vallarta, available to rent from private owner. On the beach, 10 feet from the water, they offer spectacular views of ocean and mountains, the biggest infinity pool in the area, an endless beach, great surf breaks, great fishing, tremendous views of whales, bird life and the islands. While uncrowded and tranquil, just a five-minute walk to several waterfront restaurants. Choose from a spacious, beautifully furnished one or three-bedroom unit, or an amazing two-story penthouse with lovely shade trellis on the top floor. See details at website: www.puntamitabeachfrontcondos.com. To reserve, call Dona de Mallorca, (415) 599-5012.

WANTED

LOOKING FOR PARTNERSHIP. On small catamaran. San Francisco Bay. Negotiable. Looking for partnership on small catamaran on the Bay. Have 18-ft Hobie Cat in Santa Cruz and 38-ft keelboat in SF Bay. Would like to sail a small cat (wetsuit + trapeze) in SF without trailering from Santa Cruz to the Bay and back. If you have a small cat "near" a ramp and need/want experienced sailors to help you with it let us know. Contact (831) 297-3059 or pierre.patino@gmail.com.

21'- 23' SAILBOAT WANTED. For SF Bay. In good condition. Please contact RobynBrown.thefarm@gmail.com and RichardGroh@gmail.com.

TEMPORARY LODGING. Sausalito, CA. Looking for temporary lodging (2 to 4 months) in Sausalito area. Self-employed female with project accounts in the Bay Area needs to move closer to clients and sailing. No pets, no children, no drinking and no drugs. Access to 24/7 Internet a must. Would consider sublet, home share/in-law or stay on a boat. Sailing community references available. I am a member of a local yacht club. Email sausalitotemphousing@yahoo.com.



Yacht Harbor on the Delta Loop!

28'-50' Slips and Side Ties, RV & Tent Camping

1200 Brannan Island Road, Isleton

www.brunosisland.com • (916) 777-6084

Latitude 38 eBooks

FREE * AVAILABLE WORLDWIDE *

www.latitude38.com/ebooks.html

Marine Surveyor

NAMS CMS

Consulting - Deliveries

bluwater@juno.com • (916) 599-5241



COMPLETE MARINE WOODWORK

Design / Restoration • Expert European Craftsmanship • Interior / Exterior Repairs / Maintenance • Marine Windows & Frame Replacement

Wood & Dry Rot Repairs • Varnish Work • Marine Painting

Reasonable Rates • (415) 453-2231 • References Available



*A Sailor's
Consignment
Chandlery*

NEW & USED BOAT GEAR
Open Tues.-Sat. 10 to 5 p.m.

510-769-4858
Located at Grand Marina

Official
Sponsor
2012
BAJA
HA-HA

www.bluepelicanmarine.com

GEAR

NEW 8-MAN DSB LIFERAFT. In canister. Marina Bay Yacht Harbor, Richmond, CA. \$4,000. New (October 2012) 8-man DSB offshore liferaft, fully certified until end of 2014, in canister. (415) 497-0777 or (415) 999-2426 or adesmot@yahoo.com.

MONITOR WINDVANE. Channel Islands Harbor, Oxnard. \$3,200. One year old Monitor windvane in perfect condition. Has about 3 weeks use from a one-way passage to Hawaii steering a Pacific Seacraft Dana 24. All parts included except transom mounts. Email mwilson501@gmail.com.

74-FT MAST. Designed for catamaran. Best offer. (415) 269-5165.

SHARE OFFICE. Light manufacturing space. \$800. Clean bright sunny space on Sausalito waterfront. Approximately 500 sq. ft. Free parking and good company. (415) 332-2509.



BAY AREA HIDEAWAY. Mill Valley, CA. Large 1 bedroom apartment, 2 short, flat blocks from downtown Mill Valley, and close to the Bay, beaches and hiking. This is an upper unit, 2 decks, one above a babbling creek, the other beneath the redwoods. Well equipped AEK with dishwasher, full bath, large bedroom with queen size bed. Covered parking, washer/dryer on premises. Hi-speed Wi-Fi, cable, DVD. \$120 a night, 2 night minimum. No smoking, no pets. See more at www.airbnb.com/rooms/160781. (415) 225-0442 or francicowan@yahoo.com.

PROPERTY SALE/RENT



FULLY FURNISHED STUDIO APT. For rent. Dolores Park location. Convenient to everything. Queen bed, full kitchen. Stocked BR. Views. Month to month lease / 2 night minimum. \$2,500/month, \$175/night. 1 per long term, 2 max. Contact (415) 793-5546 or (415) 641-8490 or Castro126@gmail.com.



DELTA WATERFRONT PROPERTY. Gentleman's Ranch. 3 Mile Slough - Rio Vista. \$695,000. 28-acre ranch with 70 foot deep-water dock. Property has view of Mt. Diablo. Site for second home. Property features: many outbuildings with water troughs, small corral, etc; livestock (sheep, goats, llamas, alpacas, horses, etc.) production or Ag production (presently hay); hay barn; equipment storage; fruit trees; 1,440 sq ft home with new carpet, paint, appliances, ductless air/heating system, 900 sq ft 2 car garage/shop with built-in cabinets, laundry room, mudroom, office; large carport; security system. www.century21.com. For more information, call Rebecca Cabral, (707) 249-4479 or rc1942@aol.com.

BERTHS & SLIPS

PIER 39, 36 X 13 SLIP. Pier 39. \$5,850/best offer. Nice 36-ft slip, C-20 close in. Great for America's Cup. Contact (808) 292-1100 or yachtshi@lava.net.

40-FT BOAT SLIP FOR RENT. Pier 39. \$400 per month. Great boat slip in the heart of San Francisco! Yet away from the crowds. Security, discount parking, shower and laundry facilities. (425) 643-0614 or (206) 321-3730.

PIER 39 MARINA BERTH FOR SALE. San Francisco. \$20,000/obo. 40 x 14 foot berth, currently leased at \$420 per month, SF property tax \$330 per year, visit website for photo slide show: www.415images.com/pier39. Contact Larry, (907) 225-3040 or loloane@hotmail.com.

50-FT SLIP, SF, PIER 39, G DOCK. Slip 22. San Francisco. \$55,000 - Lease to 2034. Next to breakwater - looking out on the Bay. Wow, what a view! Angel Island, Treasure Island, Golden Gate, Oakland Bay Bridge and Alcatraz. Convenience of the marina office and showers nearby. Contact bruceandbarbie@aol.com or (530) 274-2007.

AEOLIAN YACHT CLUB/MARINA. Alameda. A full-facility club with slips, workshop, kitchen and hall. Berths under \$5/foot! Special Discount for New Renters: Every 3rd month free during the first 12 months! Membership required. Reduced initiation fee: \$200. More at www.aeolianyc.com. (510) 523-2586 or aeolianyc@aol.com.



BAR OPEN DAILY TILL 9 PM
LIVE LATIN MUSIC
Saturday & Sunday 5:30-8:30 pm
with an outdoor BBQ 5-8 pm

WEEKENDS
Brunch Served 9:30 am-4:30 pm

WEEKDAYS
Lunch Served M-Th 11 am-3 pm
Fridays 11 am-3:30 pm
Happy Hour M-F 4-7:30 pm

Available for parties too!

(415) 621-2378 855 Terry François St., San Francisco
www.theramprestaurant.com

Like The Ramp on Facebook www.facebook.com/TheRampSF

FAST SHIPPING!

NEW AND USED SAILS!

Specializing in production boats and featuring the largest selection of stock sails available anywhere! Save with warehouse volume discounts on Stock Sails, Custom Sails, Sail Covers, Furlers and Accessories. All top Quality.

All Fully Guaranteed!

- Full Batten Mains
- Furling Genoa's
- Storm Jibs
- Trysails
- Furling Units
- Custom Canvas
- Used Sails

THE SAIL WAREHOUSE
Ph. (831) 646-5346 www.thesailwarehouse.com

**Mobile Marine Navigation
Installations and Marine
Electrical Work
POWER
& SAIL**

VESSEL ELECTRIC

GARMIN
certified installer

Raymarine
certified installer

Milltech Marine AIS **NAVPOD**

Brian Theobald • (415) 424-2204 • vesselelectric@yahoo.com

50-FT G16 BERTH. For sale or lease. Pier 39. Best offer. Great bulkhead location on waterfront, newly dredged. (831) 345-5732 or porisek@hotmail.com.

50-FT COMMERCIAL SLIP. San Francisco. Pier 39. \$55,000. Newly constructed J-Dock, slip-6, west side with views of Golden Gate Bridge, Angel Island, and Alcatraz Island. Special rates for owners at Pier 39 parking garage. Sublease until 2034, contact James. (650) 520-4607 or jvandyke100@yahoo.com.

50-FT PRIME SLIP, PIER 39, SF. \$50,000. F-Dock, Slip 11, east side. Protected from wind. Close to gangway, showers and marina office. Covered parking across street with special rates for owners. (559) 355-6572 or scorch@tempest-edge.com.

45-FT SLIP, PIER 39 MARINA, A DOCK. Slip 15. San Francisco. \$49,000/obo. Long lease to 2045. Ideal location for upcoming America's Cup in the heart of San Francisco! Recently dredged to 8.5 feet at low tide. Wide turnabout channel. The only wheelchair accessible dock in marina. Convenient - closest dock to Boardwalk. Fantastic views of the Bay, Alcatraz, and Angel Island. Tenants enjoy discounted rates at Pier 39 parking garage, shops, restaurants and Pier charters. Includes 24hr. security, excellent upgraded shower/laundry facilities and lounge with Wi-Fi. Quiet, non-windy side of pier with little surge. Safe and family friendly. Contact (905) 257-6278 or jon@jonwhitman.eu.

SUBLET 30-FT SLIP IN SAUSALITO. Marina Park Plaza. \$375/month. Looking to be closer to the action in 2013? Our family sailboat slip in Sausalito can be made available for sublet for 3 month, 6 month, up to 1 year. For more info, email relaxing_crew@comcast.net.

CREW

EXPERIENCED CIRCUMNAVIGATOR. 44-ft schooner, seeks select crew for attempted traverse of NW Passage. 3 legs: VA-Greenland-Cambridge Bay-Alaska, May 15 - October, 6-8 week legs. Must be fit, some experience, share expenses. For details contact Mike Johnson. (505) 466-6326 or cfays@earthlink.net.

OFFSHORE SAILING VOYAGES. Train aboard *Six String* 35-ft cutter just returned from circumnavigation of Pacific. Intensive one-on-one course conducted at sea. Sliding scale tuition based upon your experience and choice of destination. www.rosewindcorporation.com. (970) 635-0346 or shellgamer@aol.com.

OFFSHORE INSTRUCTION. John and Amanda Neal provide documented ocean passagemaking instruction aboard *Mahina Tiare III*, their Hallberg-Rassy 46, drawing on their combined 584,000 miles and 73 years experience. More info at www.mahina.com or (360) 378-6131.

OFFSHORE PASSAGEMAKING INSTRUCTION IN THE SOUTH PACIFIC

John & Amanda Neal are dedicated to providing hands-on, documented instruction aboard their Hallberg-Rassy 46 *Mahina Tiare III*, drawing on their combined 584,000 miles and 73 years of experience. www.mahina.com • (360) 378-6131

Going Somewhere?

Mexico ≈ Caribbean ≈ South Pacific

Stop by our office and take a bundle of *Latitude 38* magazines along with you. *We promise you'll be a hero for sharing them with other cruisers!*

Latitude 38 • 15 Locust Ave • Mill Valley, CA • (415) 383-8200 • Open M-F 9-5

PERSONALS

SEEKING COMPANION. Los Gatos, CA. Wish to meet retired gentleman. I had a sailboat, but sold it and miss sailing on the Bay. I enjoy dancing to big band music, good food, watching sports and movies and TV. Contact (707) 815-0932 or ddoloresmc@gmail.com.

JOBS WANTED

PART-TIME CAPTAIN. USCG Master 50 GT with tow, looking for interesting part-time work on the water in Bay Area. Retired successful businessman, mid-50s, with great people skills. Contact Michael Long, michael@longfinancial.net or (707) 483-0191.

JOB OPPORTUNITIES

MARINE TECHNICIAN. Hirschfeld Yacht is a Bay Area leader in the sales, repair, service, installation, and customization of marine diesel engines and generators. We are looking for marine technicians to join our team. Minimum qualifications: 2+ years direct mechanical/electrical experience. Experience with gas and diesel engines ranging from 10-300hp, inboards and outboards. Experience with manufacturers such as Mercruiser, Mercury, Honda, Yamaha, Beta Marine, Yanmar, Perkins, Volvo, or Universal. Expertise in electrical systems with a solid understanding of electrical fundamentals. Clean background check. Must have a California driver's license and car/truck. Must have own tools and mobile tool kit/bag. Preferred qualifications: ABYC Certifications, manufacturer specific certifications, gas/diesel technology certifications, electrical certifications. For more information and to apply, email: hycbetawest@gmail.com.

BUSINESS OPPORTUNITIES



LIVE THE DREAM \$250,000. 30 year established charter business for sale. *Sadie Sea* operates out of St. John / U.S. Virgin Islands and is certified to hold 31 passengers. Contract with National Park Service to pick up hikers and many other partnerships. New paint, survey, lower decks and stability test summer 2012. www.sadiesea.com. Email for more details: sadieseacharters@gmail.com.



VOLVO PENTA

ENGINES • PARTS • SERVICE

1-800-326-5135

We Ship Anywhere



MARINE SERVICE INC

AUTHORIZED POWER CENTER

(415) 453-1001
FAX: (415) 453-8460
www.helmutsmarine.com
619 Canal Street
San Rafael, CA 94901

Mathiesen Marine

For all of your electronics and electrical needs

Sales & Professional Installation
of all major brands of marine electronics



GARMIN
AUTHORIZED INSTALLER

We Wish Everyone
a Safe & Happy
Holiday Season!



Visit our showroom located at
3300 Powell Street, Emeryville

(510) 350-6622 www.MathiesenMarine.com

QUALITY CRUISING SAILS FOR LESS!

LEE SAILS

10%
DISCOUNT

MAINSAILS
MIZZENS
STAYSAILS
HEADSAILS
SPINNAKERS
SAILCOVERS
STRONGTRACK

leesails@aol.com

(707) 386-2490

SAILMAKER TO THE WORLD

New and
Used
Sails.



Specializing
in Sail Repair
and Service.

Marchal Sailmakers

2021 ALASKA PACKER PLACE, ALAMEDA, CA 94501

Dominic Marchal • (510) 239-5050

www.marchalsailmakers.com

Please read before submitting ad

Classy CLASSIFIEDS

Here's What To Do:

Write your ad. Indicate category, price and contact info. We make final determination.

Count the words. Anything with a space before and after counts as one word. We spell-check, abbreviate, edit, as necessary.

Mail your ad with check or money order deliver to our office; **OR, for the best - most exposure - of your classified ad**

Submit your ad safely online with Visa, MasterCard or AmEx at: www.latitude38.com

Ad will be posted online within two business days, appear in the next issue of the magazine, and remain online until the following issue is released.

Latitude 38 15 Locust Ave

PERSONAL

ADS

NEW DEADLINE

it is **ALWAYS** the **15th at 5 pm**

for ad to appear in the next issue.

Due to our short lead time, deadlines are very strict and include weekends & holidays.

Sorry, but...

- No ads accepted by phone
- No ads without payments
- No billing arrangements
- No verification of receipt
- We reserve the right to refuse poor quality photos or illegible ads.

class@latitude38.com

IMPORTANT!

WHAT'S IN A DEADLINE? Our Classified Deadline is now the 15th of the month, and as always, it's still pretty much a brick wall if you want to get your ad into the magazine. But it's not so important anymore when you're getting excited for your new system. Your ad gets posted to our website the day or two of submission. There's no time in the magazine to get your ad. If you're making a better ad, you should submit and renew your ad early in the month. That way your ad begins to work for you immediately. The only reason to wait for the 15th is if you're submitting an ad that you want to see in the magazine.

22-FT SANTA BARBARA, 1973. Alameda, CA. Includes main, spinnaker, jib, motor. Boat seaworthy, but needs exterior paint. (360) 666-4999 or (925) 323-2577 or alpsail@comcast.net

24-FT. 1993 Redwood Marina. \$4,500. Great Bay boat! Main w/single reef, Harken roller furling jib, 5hp outboard. Includes: 120/12 v. systems, VHF, WS/WP, speed, depth, autopilot. Cockpit cushions, teak cockpit table. Jibs: self tacking, 115, 150, and asymmetrical spinnaker, all in perfect condition. New last 4 years: main, jib, Harken furler, standing/running rigging. New bottom paint 2012. Call (707) 252-4467.

1973. \$2,000. Includes: main, spinnaker, jib, motor. Boat seaworthy, but needs exterior paint. (360) 666-4999 or (925) 323-2577 or alpsail@comcast.net

22-FT ISLANDER, BAHAMA, 1965. Includes: main, spinnaker, jib, motor. Boat seaworthy, but needs exterior paint. (360) 666-4999 or (925) 323-2577 or alpsail@comcast.net

22-FT ISLANDER, BAHAMA, 1965. Includes: main, spinnaker, jib, motor. Boat seaworthy, but needs exterior paint. (360) 666-4999 or (925) 323-2577 or alpsail@comcast.net

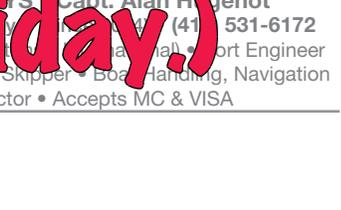
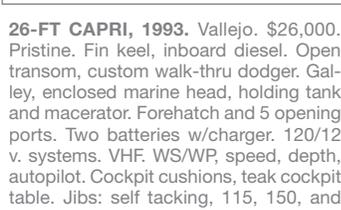
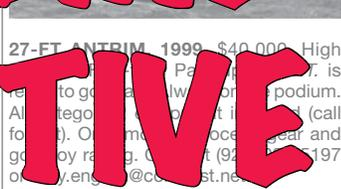
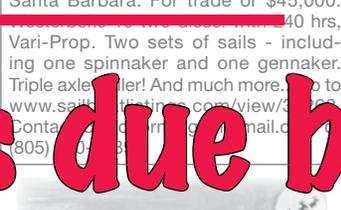

J/22, 1983. San Francisco/Monterey. \$13,000/obo. Proven winner, epoxy bottom, dry sailed since 2003, clean interior, dry, several sets of sails including 120/12 v. systems, VHF, WS/WP, speed, depth, autopilot. Cockpit cushions, teak cockpit table. Jibs: self tacking, 115, 150, and asymmetrical spinnaker, all in perfect condition. New last 4 years: main, jib, Harken furler, standing/running rigging. New bottom paint 2012. Call (707) 252-4467.

22-FT ISLANDER, BAHAMA, 1965. Includes: main, spinnaker, jib, motor. Boat seaworthy, but needs exterior paint. (360) 666-4999 or (925) 323-2577 or alpsail@comcast.net

WOODRUM MARINE
Specializing in custom cabinetry, tables, cabinets, counter tops, cabinsoles. For power or sail.
415-420-5970
www.woodrummarine.com

WOODRUM MARINE
Specializing in custom cabinetry, tables, cabinets, counter tops, cabinsoles. For power or sail.
415-420-5970
www.woodrummarine.com

N.E. MARINE
Coast Guard documentation, title, sales, repairs, private pilots, 15 years experience of doing it right the first time.
1150 Ballena Blvd, Alameda, CA • (510) 521-4925

22-FT ISLANDER, BAHAMA, 1965. Includes: main, spinnaker, jib, motor. Boat seaworthy, but needs exterior paint. (360) 666-4999 or (925) 323-2577 or alpsail@comcast.net

22-FT ISLANDER, BAHAMA, 1965. Includes: main, spinnaker, jib, motor. Boat seaworthy, but needs exterior paint. (360) 666-4999 or (925) 323-2577 or alpsail@comcast.net

22-FT ISLANDER, BAHAMA, 1965. Includes: main, spinnaker, jib, motor. Boat seaworthy, but needs exterior paint. (360) 666-4999 or (925) 323-2577 or alpsail@comcast.net

MAINE SAILING
Capt. Alan Hogenot
415-531-6172
Master's License, Boat Engineer, Yacht Manager, Delivery Skipper, Boat Handling, Navigation & Safety Instructor • Accepts MC & VISA

27-FT ANTRIM 1999. \$40,000. High performance, 120/12 v. systems, VHF, WS/WP, speed, depth, autopilot. Cockpit cushions, teak cockpit table. Jibs: self tacking, 115, 150, and asymmetrical spinnaker, all in perfect condition. New last 4 years: main, jib, Harken furler, standing/running rigging. New bottom paint 2012. Call (707) 252-4467.

26-FT CAPRI, 1993. Vallejo. \$26,000. Pristine. Fin keel, inboard diesel. Open transom, custom walk-thru dodger. Galley, enclosed marine head, holding tank and macerator. Forehatch and 5 opening ports. Two batteries w/charger. 120/12 v. systems. VHF. WS/WP, speed, depth, autopilot. Cockpit cushions, teak cockpit table. Jibs: self tacking, 115, 150, and asymmetrical spinnaker, all in perfect condition. New last 4 years: main, jib, Harken furler, standing/running rigging. New bottom paint 2012. Call (707) 252-4467.

28-FT HARKEN, 1993. Yanmar 120/12 v. systems, VHF, WS/WP, speed, depth, autopilot. Cockpit cushions, teak cockpit table. Jibs: self tacking, 115, 150, and asymmetrical spinnaker, all in perfect condition. New last 4 years: main, jib, Harken furler, standing/running rigging. New bottom paint 2012. Call (707) 252-4467.

WOODRUM MARINE
Specializing in custom cabinetry, tables, cabinets, counter tops, cabinsoles. For power or sail.
415-420-5970
www.woodrummarine.com

MAINE SAILING
Capt. Alan Hogenot
415-531-6172
Master's License, Boat Engineer, Yacht Manager, Delivery Skipper, Boat Handling, Navigation & Safety Instructor • Accepts MC & VISA

WOODRUM MARINE
Specializing in custom cabinetry, tables, cabinets, counter tops, cabinsoles. For power or sail.
415-420-5970
www.woodrummarine.com

WOODRUM MARINE
Specializing in custom cabinetry, tables, cabinets, counter tops, cabinsoles. For power or sail.
415-420-5970
www.woodrummarine.com

WOODRUM MARINE
Specializing in custom cabinetry, tables, cabinets, counter tops, cabinsoles. For power or sail.
415-420-5970
www.woodrummarine.com

WOODRUM MARINE
Specializing in custom cabinetry, tables, cabinets, counter tops, cabinsoles. For power or sail.
415-420-5970
www.woodrummarine.com

THREE NEW LAGOON DESIGNS COMING

NICOLAS CLARIS



LAGOON 400S2

This fall, Lagoon is introducing three new models to the family of world leading, world cruising catamarans.

As always, they come from the design group VPLP. We think VPLP has been the clear leader in high performance multihull design for many years. The amazing success of the Lagoon family is only one part of the proof.

For a close look at the great work of this group, go to their website at: www.vplp.fr. If there's something familiar looking in there, maybe you've heard something about BMW Oracle.

Call us, or write, or watch the various sites for details about the new Lagoons!



www.catamaranaccess.com
(510) 469-3330 · (408) 828-7299

CATAMARAN ACCESS

Remember Your Crew This Holiday Season...

Give the gift of

Latitude 38 Logowear



PLACE YOUR
ORDER BY DECEMBER 13
FOR DELIVERY IN TIME
FOR CHRISTMAS

Order online at:

www.latitude38.com

or by mail:

Latitude 38 Logowear

15 Locust Ave., Mill Valley, CA 94941

ADVERTISERS' INDEX

AB Marine..... 6	Boat Yard at Grand Marina, The..... 24	Doyle Sails 53	Hansen Rigging 57	Lewmar Marine..... 42
Alameda Eyes Optometry 52	BoatSmith Marine Carpentry & Boatbuilding..... 61	Dr. LED..... 128	Helms Yacht & Ship Brokers 142	List Marine Enterprises ... 54
Almar Marinas..... 31	BottomSiders..... 97	e Marine Systems 105	Helmut's Marine Service..... 139	Loch Lomond Marina..... 47
Alpenglow Marine Lights 104	Brisbane Marina 41	Easom Rigging..... 97	Heritage Marine Insurance 60	Makela Boatworks..... 111
American Battery 105	BVI Yacht Charters..... 115	El Salvador Rally/ Bahia del Sol..... 131	Heritage Yacht Sales.... 144	Marchal Sailmakers..... 139
Aqua Marine 129	CYOA Yacht Charters.. 114	Emery Cove Yacht Harbor..... 39	Hirschfeld Yachts 43	Marina Bay Yacht Harbor..... 35
Bacon Sails & Marine Supplies 41	California Professional Divers Association 104	Emeryville Marina 100	Hogin Sails 22	Marina de La Paz..... 126
Baja Ha-Ha Sponsors 85, 86, 87	Catamaran Access 141	Equipment Parts Sales.. 130	Hood Sails..... 19	Marina El Cid 84
Ballenger Spars..... 41	City Yachts..... 11	Essex Credit Corp..... 40	Hotwire Enterprises..... 130	Marine Lube 97
Barz Optics 45	Clipper Yacht Harbor..... 8	Farallone Yacht Sales..... 9	Hydrovane..... 128	Marine Outboard Company 26
Bay Marine Boatworks... 21	Club Nautique 34	Flying Cloud Yachts 143	Intrepid Landing 50	Mariner's General Insurance 49
Bay Marine Diesel..... 97	Conch Charters..... 114	Forespar..... 110	Iverson's Design 59	Maritime Institute..... 50
Berkeley Marina..... 25	Corinthian Yacht Club.. 111	Fortman Marina..... 46	JK3 Nautical Enterprises 17	Marotta Yachts 146
Berkeley Marine Center..... 57	Cover Craft..... 53	Gentry's Kona Marina ... 97	KKMI - Brokerage..... 145	Mast Mate 126
Blue Pelican 138	Coyote Point Marina..... 96	Gianola Canvas Products..... 43	KKMI - Boatyard 148	Mathiesen Marine 139
Blue Water Yacht Insurance 58	Cruising Yachts 7	Gold Coast Yachts..... 47	Kissinger Canvas..... 49	Mayne, Larry R., Yacht & Ship Broker 10
	Defender Industries..... 61	gotzinc.com 142	Lee Sails 139	
	DeWitt Studio 101	Grand Marina 2		

CONTINUED



(510) 865-2511

www.helmsyacht.com

Dealer for Seawind Catamarans • Corsair Trimarans • Dragonfly Trimarans



2008 SEAWIND 1160
\$429,000



2002 NEWICK 50
\$379,000



SEAWIND 1000
\$145,000



CORSAIR TRIMARANS
24'-37' • Call for test sail

got zinc?

boat bottom scrubbing & more...

zinc replacements • propeller changes
thru-hull inspection & replacement



415.331.SAIL www.gotzinc.com william@gotzinc.com

www.pacificmaritimelaw.com

Maritime Law Offices of Jared A. Washkowitz

SF Bay Area | So. Cal. | Hawai'i

Vessel Documentation
Fed. & State Regulation
Charter Parties
Personal Injuries
Wrongful Death
Maritime Liens
Vessel Arrests
Limitation of Liability
Towage

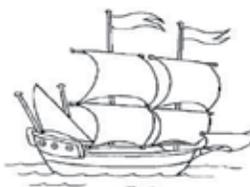

Collision/Allision
Vessel Financing
Cargo Loss & Damage
Longshore Act
Jones Act
Wreck Removal
Salvage
Marine Insurance
+ other practice areas

Email: jaw@pacificmaritimelaw.com

PH: +1 (415) 320-8254 (Calif.) | +1 (808) 840-7410 (Haw.)



ADVERTISERS' INDEX – cont'd

Mazatlan Marine Center/ La Paz Yachts 45	Pacific Offshore Rigging..... 59	Scandia Marine 28	Twin Rivers Marine Insurance 56	West Marine..... 16, 18, 20
McDermott Costa Insurance 52	Paradise Village..... 33	Schoonmaker Point Marina 44	Vallejo Marina 49	West Marine - Rigging... 48
McGinnis Insurance..... 55	Passage Yachts..... 5	Seashine..... 56	Ventura Harbor Boatyard..... 55	Westwind Precision Details 37
Minney's Yacht Surplus... 126	Pineapple Sails 3	Seatech 130	Vessel Electric..... 138	Whale Point Marine Supply 32
Modern Sailing School & Club 51	Punta Mita Beachfront Condos 105	South Beach Harbor 36	Washkowitz, Jared A., Maritime Law Offices . 142	White, Chris Designs... 105
Multihull Co., The 143	Quickline..... 58	South Beach Riggers..... 37	weatherguy.com..... 126	Wiest, Michael, Yacht Sales..... 39
Napa Valley Marina..... 53	Raiatea Carenage Services 127	Southbound Solar 129	Wedlock, Ramsay & Whiting Marine Surveyors 105	Yachtfinders/Windseakers 43
New Era Yachts..... 144	Ramp, The 138	Spectra Watermakers .. 104		
Norpac Yachts 147	Richardson Bay Marina 57	Sperry..... 23		
North Beach Marine Canvas 37	Sail California..... 12, 13	Starbuck Canvas 130		
North Direct Sails..... 47	Sail Warehouse, The ... 138	Start Line Strategies..... 111		
North Sails 27, 54	Sailrite Kits 38	Stem to Stern 45		
Opequimar Marine Center..... 84	Sal's Inflatable Services 51	Sterling Associates 60		
Outboard Motor Shop... 51	San Diego Boat Movers..... 101	Svendsen's Boat Works .. 15		
Owl Harbor Marina 55	San Francisco Boat Works..... 91	Svendsen's Marine 30		
Oyster Cove Marina 59		Swedish Marine 61		
Pacific Crest Canvas 14		Swi-Tec America 104		
		TMM Yacht Charters.... 115		
		Tracsa 29		
		Trident Funding 4		



*Holiday
Greetings
from our
crew
to yours*



Flying Cloud Yachts



6400 Marina Drive
Long Beach, CA 90803

Sail • BROKERS • Power
www.flyingcloudyachts.net
flyingcloud@verizon.net

Phone (562) 594-9716
Fax (562) 594-0710



36' CATALINA SLOOP, '86 \$59,900



50' KETTENBURG, '64 \$95,000



46' SWAN, '84 ~~\$229,000~~ \$199,000



46' CAL 2-46, '73 \$119,000



52' ENDEAVOUR CUTTER, '90 \$239,000



40' BABA, '80 \$120,000



43' MASON CUTTER, '79 \$124,500



34' PACIFIC SEACRAFT, '88 \$93,000



36' CATALINA MKII, '99 \$76,000



41' DRISCOLL BRUCE KING, '76 \$179,000



41' ERICSON, '69 \$64,000



30' CATALINA TALL RIG, '88 \$27,900

APPROX. 100 LISTINGS ON OUR WEB SITE: www.flyingcloudyachts.net



THE MULTIHULL COMPANY

THE WORLD'S LEADER IN MULTIHULL SALES AND SERVICE

www.multihullcompany.com

The Multihull Company is pleased to announce the opening of the Northwest Multihull Center on Puget Sound's Commencement Bay. The Northwest Multihull Center is a great starting place for buying or selling a catamaran or trimaran or to learn more about the world of multihulls. We are creating the West Coast's largest concentration of catamarans and trimarans to serve you better!

The Multihull Company is the world's largest international catamaran and trimaran brokerage. Our team of multihull experts offer several distinct differences including buyer and seller services, a powerful online presence, worldwide offices, displays at major national and international boat shows, newsletters and social marketing that inform and reach the right buyers and sellers. Visit us at www.MultihullCompany.com or at our new Northwest Multihull Center and see why The Multihull Company is truly the choice for sailors around the world.

FEATURED WEST COAST LISTINGS



50' CATANA, 2008
Washington
€700,000



38' LEOPARD M3800, 2001
California
\$199,900



CATANA 471, 2001
Washington
\$574,000



42' FONTAINE PAJOT
VENEZIA, 1995
Washington \$235,000



34' GEMINI 105MC, 2008
Washington
\$153,000



36' CORSAIR C36, 2004
San Francisco, CA
\$199,500

SAN FRANCISCO SEATTLE FT. LAUDERDALE CHARLESTON FRANCE TURKEY TRINIDAD TORTOLA ST. MARTIN KOREA
HQ Phone: 215-508-2704 Northwest Multihull Center: 206-297-1151 email: info@multihullcompany.com



DEALERS
FOR CATALINA
SAILBOATS AND
HANS CHRISTIAN
SAILBOATS

Long Beach-Naples
Newport Beach
San Diego
Wilmington

866-569-2248
877-389-2248
760-402-3868
877-599-2248
Cell 310-995-9989

www.heritageyachts.com



65' MacGregor, '90 \$232,000



54' Jeanneau DS, '06 \$479,000



50' Celestial PH, '00 \$320,000



50' Santa Cruz, '86 \$129,000



47' Beneteau 473, '03 \$235,000



41' Hunter DS, '08 \$184,500



40' Hunter, '97 \$119,900



40' Lagoon, '10 \$425,000



39' Beneteau 393, '03 \$125,000



38' Hunter, '01 \$89,000



38' Catalina, '82 \$44,900



31' Pacific Seacraft, '07 \$159,500

CALL TO TOUR THESE BOATS!



50' VALIANT, 2001
An extraordinary yacht that is ready for your inspection.
\$535,000

56' FORMOSA, 1981
World famous cruising ketch, *Lost Soul*, outfitted and ready to go again. Ready for inspection at our docks and on our website. Beautiful!
\$275,000



57' ALDEN YAWL, 1931
Own a Master Mariners treasure.
\$249,000



51' FORMOSA, '79
Ready to cruise the Caribbean. Already there!
\$145,000



39' C&C CC, '85
Mexico ready, comfortable performance cruiser.
\$69,900



36' CATALINA, '85
Well cared for. Ready to sail. Canvas, dodger, furler, more.
\$35,000

39' CHB Trawler, '79 \$58,500 • 37' HERSHINE, '86 \$79,000 • 36' CATALINA, '85 \$35,000 • 30' CATALINA, '80 \$25,900 • 22' SANTANA, '75 \$3,750



2021 Alaska Packer Pl., Grand Marina, Alameda, CA 94501
sales@newerayachts.com • daboatman@sbcglobal.net
(510) 523-5988 • www.newerayachts.com



PASSENGER COI CHARTER VESSEL



PASSENGER COI CHARTER VESSEL

To legally operate a charter with more than 6 passengers, a vessel must meet construction and inspection requirements of the USCG and be awarded a Certificate of Inspection (COI). Buying new or retrofitting can be prohibitively expensive. Purchasing an active COI vessel is the most cost-effective means to enter this market. These two vessels are ready to go, and each is self-supporting in its current business model. Call to learn more!

Quality Yachts and Unique Opportunities



HINCKLEY BERMUDA 40 MkII Yawl CB (1968)
Invictus is a classic Bill Tripp design in truly excellent condition. Many new updates.
\$119,000



BURGER 72 PILOTHOUSE YACHT (1964)
Papagallo II's luxurious "Onboard Nautical Events" attract intimate parties of two and celebrations of 40-60. Great SF Bay opportunity.
\$595,000



MUMM/FARR-OVINGTON 30 (1997)
Trunk Monkey is ready to join the SF Bay Class. Well built, spectacular racing history. Many, many upgrades.
\$57,900



SKIPPERLINER 63 (1996)
Steel construction, twin CAT diesels, operates as "Delta Discovery Cruises" certified for Bay and Delta cruises with 83 passengers.
\$247,500



BALTIC 42 DP (1981)
Why Not is Doug Peterson's award-winning design for full comfort performance cruising. Motivated seller, Sausalito berth in very desirable location transfers with application approval. **\$75,000**



HALLBERG RASSY 37 (2006)
Further was commissioned by original owner in Sweden and sailed singlehanded for over 6 years with recent arrival in San Francisco. Well-built long distance cruiser. Shared listing. **\$309,000**



We are in the process of listing several exciting new yachts. Use the code to see our most current inventory.



www.kkmi.com/yacht-sales

(510) 236-6633 • fax: (510) 231-2355

yachtsales@kkmi.com

530 W. Cutting Blvd., Pt. Richmond, CA 94804

The Bay Area's Premier Boatyard and Brokerage – An Unbeatable Combination

Now accepting quality new listings.

Contact Listing Manager
terri@kkmi.com



Marotta Yachts of Sausalito

Brokers of Fine Sail and Motor Yachts

415-331-6200 • info@marottayachts.com • www.marottayachts.com

See at: www.marottayachts.com



47' CATALINA 470, 2008 Dark blue hulled beauty shows as new inside and out, only 50 hours on Yanmar. In-boom main, electric winches, bow thruster, custom hard dodger with Barrett Bonded glass. Transferable Sausalito Yacht Harbor slip. **\$349,000**

See at: www.marottayachts.com



41' SCEPTRE CUTTER, 1985
Updated throughout, professionally maintained, transferable Sausalito Yacht Harbor slip. **\$174,900**

See at: www.marottayachts.com



48' ISLANDER SLOOP, 1985
Pacem has had only two long-term owners since new, and shows absolutely beautifully today. New sails. **\$159,000**

See at: www.marottayachts.com



52' CUSTOM COLD-MOLDED SCHOONER, 1999 Her keel was laid in '72, she then sat unfinished in covered shed until current owners discovered her in '95; meticulously finishing her out before & after '96 launch; then christened/documentated in '99. **\$149,000**

See at: www.marottayachts.com



38' TA SHING PANDA, 1983
Gary Grant-designed classic beauty with brightwork and interior showing MUCH newer than her age. New interior upholstery and foam. Sails well, will make a perfect cruiser. **\$129,900**

See at: www.marottayachts.com



43' SLOCUM CUTTER, 1984
Cruising cutter that has been well maintained and extensively updated — owners estimate they spend about \$10,000 yearly. **\$129,000**

See at: www.marottayachts.com



36' UNION POLARIS, 1981 Only one owner since new, *Phantom* has never been cruised, extensively upgraded over the years, and is bristol inside/out. Must be seen to be appreciated, a contender for anyone in the market for a traditional cruiser. **\$79,000**

See at: www.marottayachts.com



53' ISLANDER, 1979
Over \$100,000 spent over past several years on this vessel. Rewired, new fuel tanks, extensive upgrades. Owner is motivated to sell IMMEDIATELY. **\$79,000**

See at: www.marottayachts.com



37' HUNTER LEGEND 37.5, 1993 37.5 was one of Hunter's most popular designs ever and this particular low-time example is very clean inside and out, competitively priced and lying in Sausalito Yacht Harbor slip that's potentially transferable. **\$67,000**

See at: www.marottayachts.com



33' WAUQUIEZ, 1984 Classic European sloop shows much newer than actual age — interior in particular shows as new. Major refit '97 included a much more powerful 30 hp diesel, B&G electronics, Harken roller furler, sails, heavy-duty dodger, etc. **\$59,000**

See at: www.marottayachts.com



30' FORTUNE PILOTHOUSE CUTTER, 1978 This charming custom pilothouse feels WAY bigger than 30"! She also has much new equipment (including new Isuzu diesel installed in '95), shows pride of ownership throughout, and is a must-see. **\$43,500**

See at: www.marottayachts.com



45' STARRATT & JENKS, 1977
Nice aft cockpit sloop with new Yanmar diesel (\$30,000 project). Great value cruiser or liveaboard. **\$39,000**

NORPAC YACHTS

1150 Brickyard Cove Rd., B9, Pt. Richmond, CA 94801

(510) 232-7200 • FAX (510) 232-7202

email: info@norpacyachts.com

**WE NEED
MORE BOATS...
BUYERS ARE CALLING!
LIST YOUR BOAT
NOW...
IT'S FREE!**



43' STEPHENS CLASSIC Raised Deck Express Cruiser, 1931. Covered berth kept & beautiful. Charming Gatsby-era yachting in grand style. She's a work of art! Ready to go & have fun now! Twin Chryslers, more! **\$115,000**



44' STEEL Canoe-stern cutter by Geo. Buhler/Fred Lagier & Sons. John Deere diesel. Stout steel construction. Awesome bluewater cruiser built to go to sea and stay there. Radar, GPS, etc. Here's your world beater! Asking **\$62,950**



48' GRAND BANKS Trawler LRC. Aft master S/R, twin diesel, FB & PH helms, classic mahogany in BEAUTIFUL condition. Onan, fully loaded galley, 3 heads, shower & tub, inflatable dinghy w/ motor, swim platform, steadying sails, radar, MORE! Asking **\$99,950**



40' VALIANT CUTTER Great blue water cruising design that changed cruisers forever. Loaded with cruising gear, color radar, R/F, plotter, nav station, private staterooms, and MORE! A big, strong, performance world cruiser. Asking **\$69,500**



27' CANADIAN SAILCRAFT CS-27 Low hours Yanmar diesel. Exceptionally well built & just finished major refit-refinish in & out. Absolutely beautiful, this boat looks new! Roller furling, self-tailing winches, new rigging & MORE. Outstanding value. Asking **\$17,950**



35' ERICSON MkII Sloop. Near new standing and running rigging, and sails by Quantum. Profurl roller furling—all almost new, solid example of a great Bruce King design. Excellent cruiser, I/B, 13 Barient winches, wheel, 2 spinn, retrig., shower, double spreader rig and MORE! **\$24,950/Offers**



100' MEGA SLOOP

Big, beautiful; loaded with everything you might want for comfort, convenience and performance. 26+ knots under sail. 23' beam, 250 hp Cummins diesel aux, and much more.

Asking **\$695,000**



40' DUFOUR PERFORMANCE CRUISER Full electronics, roller furling, dodger, fine sail inventory, cruise equipped. Fast, comfortable, in beautiful condition and MORE! Located in Southern California, she's a MUST SEE! Asking **\$159,500**



35' SPARKMAN & STEPHENS Center Cockpit Sloop. Diesel, aft stateroom, hard (fully enclosable) dodger, good sail inventory, wheel, extra strong fiberglass construction, well found quality cruising boat. Asking **\$28,950**



49' ROSBOROUGH WINDJAMMER SCHOONER Stoutly built in Nova Scotia in 1980 of bronze-fastened white oak. 57' LOA, 13.5' beam. Loaded with character. Built to go to sea & stay there. Roomy, seaworthy design. Center cockpit, large aft strm, MORE! Asking **\$44,950**



40' X-YACHTS X-119 HIGH-PERFORMANCE sloop. Renowned Danish performance cruiser/racer. Loaded with gear and high tech sails. Proven bluewater cruiser and race winner. **\$109,000**



46' ISLAND TRADER MOTORSAILER KETCH F/G, diesel, in/out wheel steering, queen aft plus double and single staterooms, two enclosed heads with showers and tub, AIS transponder, radar, AP, roomy, more! **\$89,950**



35' TIARA 3500 XL EXPRESS CRUISER Comfort, elegance & performance in one ultra-clean package. Twin 502 XL Crusaders. Roomy & luxurious, these powerhouses are well respected for their fit, finish & overall quality in the powerboat community & elsewhere. Asking **\$114,000**

**LIST
YOUR BOAT
HERE
IT'S FREE!**



48' DUTCH CANAL BOAT by deVries Lentsch. Steel. Unique, comfortable cruiser for Bay/Delta. Diesel, tub, galley, fireplace, salon, convertible aft enclosure, beautiful decor, MORE! LIVEBOARD. A GEM! Now asking **\$144,000**



28' SOUTHERN CROSS Cutter. Famous top quality pocket cruiser designed by renowned naval architect Thomas Gilmer. Diesel, double-ender, FG. Known for seaworthiness and beauty, these fine craft are rare on the West Coast. A great opportunity. Asking **\$16,500**



46' LAKE UNION CLASSIC CRUISER, 1930. Restored/rebuilt, excellent cond., new dsls, new genset, rewired/reframed/refastened, radar, MORE! She could cruise to Seattle tomorrow. Premium covered Marin berth. Dsl cabin heat. Great liveaboard/cruiser. Asking **\$69,995**



40' NEWPORTER Ketch. "Ack" Ackerman's wonderful seaworthy and comfortable design in beautiful condition. 54 HP Isuzu diesel, 2 helms (wheel on pedestal & in pilothouse) radar, AP, cabin heat. Well set up for cruising & ready to go. Asking **\$44,950**



58' ALDEN BOOTHBAY EXPLORER Motorsailer Ketch. Aft stateroom, dsl, genset, AC, heat & MORE! Famous bluewater cruiser meant to go to sea & stay there. Excellent layout, fantastic potential. Asking **\$198,500**

PLEASE SEE www.norpacyachts.com
and/or www.yachtworld.com/norpacyachts
for MORE BOATS

**CALL (510) 232-7200 OR
TOLL FREE (877) 444-5087
OR CALL GLENN DIRECTLY AT
(415) 637-1181
FOR INFORMATION & APPOINTMENTS**



THANK YOU

The entire Team at KKMI would like to thank the racers, cruisers, day-sailors, fishermen and all the boaters who made up the extraordinary Class of 2012. We appreciate the opportunity to have served you and wish you a Happy New Year!

About Time, Adele, Adventure, Aegea, After You, Agua Azul, Ahava, Ahelani, Air, Air Jaldi, Airborne, Akela, Alaskan, Alchemy, Alcyone, Alegria, Alessandra, Alexandra, All Hail, All Ma Doe, Allegra, Allie Cat, Almar Pillar Point, Alpha, Alpha Wave, Alta, Alta Mia, Amazing Grace, Amelia, Amicus, Armond Joy, Amore Kai, Anakalia, Anakonda, Andantino, Andiamo, Angelina, Annabelle, Anne Bonny, Annie, Annie Too, Annie's Song, Another Girl, Antares, Anticipation, Aon, Aphrodite, April Dream, Aquarius, Aquatain, Aquavit, Arabella, Arbitrage, Arch Angel, Archview, Arete, Ariadne, Aries, Arugula, Asahi, Asilo, Ask Lisa, Astra, Astrea, Astrid, At Last, Atlas, August Ice, Auntie Em, Aurora, Ava J, Ava Serene, Avanti, Avida, Avion, Aviron, Awakening, Ay, Caramba, Azimuth, Azyxxi, Bagheera, Bandidocot, Barbara, Barbara J, Barge, Batteries Not Required, Bay Celebrations, Bay Gipper, Bay Voyager, Baykeeper, BB Joon, Bella Blue, Bella Luna, Bella Rosa, Belle Souers, Black Diamond, Black Mallard, Black Pearl, Black Swan, Black Witch, Blackhawk, Blazer, Blew, B-Lin, Blue, Blue Bayou, Blue By You, Blue Cosmos, Blue Coup, Blue Eyed Girl, Blue Finn, Blue Moon, Blue Pearl, Blue Streak, Bluewater, Bluzzz, Bobby McGee, Bobskat, Bohica, Boire au Soleil, Bon Di Vont, Bonne Vie, Boston Whaler, Brandi, Bravissimo, Bravo, Brezza Bella, Brigadoon, , Buddies, Buena Vida, Bumpy, C Dory, Cadance, Cal Maritime, Caledonian, Calou, Calypso, Camelot, Cancan, Cape Ommaney, Carola, Caroline, Carpe Diem, Carpe Ventum, Carquinez Coot, Carrie J, Cat 5, Catalyst, Catch 22, Cat-O-Tonic, Cat's Paw, Cavalo, Cayenne, CC's Rival, Certa Ceto, Cest La Vie, Cest Si Bon, Chance, Chanty, Chaouha, Charge, Charisma, Charlie, Charette, Chasing Dreams, Chasing the Horizon, Chayah, Cheers, Cheese Burger, Christabel, Chumash, Chumley, Ciao Bella, Cielo, Cierra, Cindy, Cinnabar, Circe, Cleo, Concise, Contessa, Conundrum, Cool Change, Copasetic, Courage, Crescendo, Criminal Mischief, Cuculainn, Cuckoo, Culebra, Curious George, Curlew, Cuvee II, Cuzco, Cygnus, Cygnus Montanus, Cythera, Czechmate, Danae, Dance Away, Dancing Bear II, Daring, Dawn, Dayenu, Deception, Del Viento, Delphinus, Delta, Demian, Density, Desert Star, Destiny, Diana, Dilemma, Discotheque, Ditzzy, Diva, Dolce Vita III, Don Miguel, Donkey Jack, Donna Mia, Don't Stop, Dorade, Double Wide, DP, Dr. Quality V, Dream, Dream Catcher, Dream Time, Dreamgirl, Eagle, Eagle Wing, Eastern Breeze, Eau Claire, Ebenezer II, Echo, Edward Letter, El Cazadore II, El Dorado, El Nido, El Yahm, Elan, Elena, Elusive, Emerald Sea, Emotional Rescue, Empress, Enchantment, Encore, Endless Summer, Ensemble, Entropy, Equinox, Equius, Erin Ann, Erinn Gale, Escapade, Escape, Excalibur, Expectations, Expeditious, Express Lane, Expression, Fair Lady, Farallon, Faster Horses, Felicia, Fertile Turtle, Fever, Fifth Season, Finally Home, Finisterra, First Love, First Tracks, Fishbone, Fitzroy, Fjord III, Flash, Fledgling, Flicka, Floating Stones, Flora M, Flourish and Prosper, Fog Cutter, Foliager, Folksong, Footloose, Fort Knots, Fortune Hunter, Fox Trot, Freaks on a Leash, Free and Clear, Free At Last, Free Energy, Free Time, Freedom, French Twist, Frequent Flyer, Frivil-Us, Frog, Full Tilt, Fun Runner, Gabriella, Gaelic Swan, Gale Force, Game Changer, Gaviilan, Gemini, Gennao, Georgie, George, Geronimo, Get Away, Gjendin, Gladiator, Glory Bound, Golden Gate Ferry, Golden Moon, Golf, Good Omen, Good Wood, Googled, Grace Note, Gracious Lady, Grand Cru II, Grand Impulse, Gratitude, Gravlax, Green Buffalo, Green Flash, Grey Ghost, Grey Goose, Grins, Grizabella, Gunga Din, Gypsy, Gypsy Rover, Hadtahav1, Haiku, Halo II, Hana Pau, Happy Talk, Harmony, Haru, Hator, Hawk Eye, Haxa, Hazardous Waste, Helgoland, Hem, Heron, Hi Spirit, High Five, High Line, High Tide, Highlander, Hombre, Horizon, Hotel California, Howsepian, Hubba Hubba, Hula Girl, Huli Cat, Hyacinth, I Sail Boat, Icfigin, Iliohale, Imagine, Imani, Impromptu, Inca, Independence, Infidel, Integrity, Interlude, Invictus, Invisible Hand, Invitation, IO, Irish Mist, Irish Rose, Isis, Island Fever, Island Girl, Islero, Ilinerant, IV Family, Jabulani, Jack Pot II, Jakatan, Jamani, Janae, Jandy, Jaqk, Jasmine, Javelin, Jerry Lou, JJ Clyde, Jocelyn, Jose Cuervo, Josephine II, Josi Ortisi, Josie Mave, Joy, JuJu, Juliefish, Juliet, Junior, Jupiter, Just Right, Kai Lani, Kallipolis, Karinga, Kate-ster, Kauehi, Kay, Kebekol, Kells, Kelly Shawn, Kelpie, Kemosabe, Kestrel, Kind of Blue, Kindred Spirit, Kira, Kir, Klyde's Ride, Kokiri, Kokomo, Kookaburra, Kuani, La Bella, La Folie, La Paloma, La Zuccherrina, Lady Ann, Lady Arwen, Lady E, Lady Hawke, Lady Jane, Lady Kate, Lady's Slipper, Laelia, Laguna Verde, Laissez Faire, Lakota, Lauren Kate, Lazy Lightening, Leapin Lizard, Leaping Warrior, Lee Hound, Lee Hound II, Leslie Jane, Liberty, Libra, Light Touch, Lillith, Linda Gayle, Linda Lee, Linda Noelle, Lindsay, Liquidity Trap, Little Dipper, Little Friend, Livin The Dream, Local Talent, Lohengrin, Love, Lucky Duck, Lulu, Luna C, Lyric, Machopekin, Magewind, Magic Cloud, Magic Juan, Magnum, Magnum 44, Mahalo, Maid Marian, Maid of Time, Maldita II, Maluhia, Mandate, Mandy Jane, Mar Saga, Mara, Marara, Margo, Mari Louise, Marpessa, Marma Lee II, Mary Morris, Masquerade, Matowii, Mattissa, Maxine, Mayhem, Meanie, Meat Compass, Mega Watts, Mei Mei, Melani, Melita, Meltemi Too, Merope, MetamorFish, Mickey Finn, Midnight Crossing, Mil Besos, Milagro, Mimi & Me, Minna, Mirage, Mirthmaker, Miss Anita, Miss Peggy, Miss Tress, Misty, Misty II, Mivida, MKADifference, Moemoea, Mojo, Mollie, Momo, Mon Ami, Monet, Monterey, Moody Blues, Moon Lighter, Moondancer, Moonlight Lady, Moonraker, Moonspun, Morning Dew, Morning Star, Moshulu, Motorcycle Irene, Moxie, My Girl, My Reen, Mykonos, Mystic, Mystique, Naia, Naiad, Naos First 30, Napa Ferry, Naughty by Nature, Nautau, Nauty Bouy, NaZdrowie, Nazdrowie, Nehemiah, Neko, Nepenthe, Neptune, Neptune's Car, New Cap't Pete, New Easy Rider, New Morning, New Rules, New Sea Angler, New Seeker, Nicholas, Nicole, Night Move, Nightingale, No Sniveling, No Velas, No Worries, Nola Ann, Nomad, North Star, Northern Lights, Nova, Nova Dos, Nu Vue, Nuance, Number One, O Canada, Ocean Gale, Oceana, Odd Job, On y va, Once Bitten, Ondine, One and Only, One Trick, One Trick Pony, Onyva, Opportunity, Optimus Prime, Oriole, Oro Blanco, Osprey, Oui B Five, Our Destiny II, Our Time, Out of Control, Outer Limits, Outsider, Outta D'Bleu, Pacific Avenger, Pacific Star, Packman, Paco II, Padme, Pagan Baby, Painkiller, Paka'a, Pale Ale, Pandion, Paoha, Papa Bear, Parachute Woman, Paraiso, Parker, Pastime, Pau Hana, Pax Vobiscum, Pearl of Oakland, Pegasus, Peggy-O, Pelagic Magic, Pelican, Pelorus Jack, Penelope, Peregrine, Pete Rose, Petite Four, Phantom, Phantome, Phoebe, Phoenix Rising, Pink Boat, Pink Slip, Pirate, Play'n Hookie, Plouf, Plus Sixteen, Pocahontas, Pogo, Pola, Polaris, Polonaise II, Polu Lani, Pooch, Popeye, Poppy, Porto, Poseidon's, Posh, Prairie Oyster, Preoccupation, Present Moment, Pretty Lady, Prezzo, Prime Cut, Princess, Princess Red Cheeks, Procyon, Puff, Pursuit, Q, Quarante-Deux, Queen Anne, Queenie, Quella Bella, Quest, Questuary, Quintana Roo, Quixote, R & R, Racer X, Radiant, Radio Flyer, Rageboge, Raider I, Raider III, Ramble On Rose, Rambunctious, Rampage, Rascal, Razor's Edge, RBW Rent, Rebecca, Rebecca Mae, Recidivist, Red Stripes, Regardless, Regulator, Relentless, Releta, Resilience, Retriever, Revelation, Richmond Police Boat, Rinnah!, Rio, Risk, Roberta M, Robin, Rochambeau, Rock & Roll, Roebot, Romance, Romantic Dancer, Rosebud, Roundabout II, Rowena, Roxsea, Royal Blueness, Ruckus, Rum Tum Tugger, RV, Sabbatical, Sabertooth, Sadhana, Sagte II, Sail Anywhere, Sailor Dog, Saint Carol, Saint Somewhere II, Salt Shaker, Salty I, Sam, Samantha, San Louis, Sanderling, Sandra Marie, Sans Souci, Santa Barbara, Santana, Sara Ann, Sarah Jane, Sashay, Satori, Saturday's Child, Saty, Sazon, Scoop, Scoots, Scorpio, Scotch Mist, Sea Banshee, Sea Bird, Sea Circus, Sea Diamond, Sea Dog, Sea Eagle, Sea Fever, Sea Glub, Sea La Vie, Sea Mistress, Sea Prince, Sea Ray, Sea Sister, Sea Sons, Sea Spirit, Sea Squirt, Sea Tender, Sea Walker, Sea Wolf, Seabird, Seacure, Seadrift III, Seafox, SeaRay, Seastainable, Seat Test, Seataker, Seawalker, Seaward, Seaya, Second Wind, Seeker, Selah, Selene, Sensei, September Song, Serena, Serendipity Too, Seute Deern, SF Joe, Shadow, Shalom, Shamrock, Shearwater, Sherrie Lynn, Shindig, Shoo Fly, Shut Up And Drive, Sihaya, Sim Querida, Simpatico, Sirena, Sirius, Sisu, Skarhi, Skeabost, Slainehe, Slam V, Sleepy Time, Slip Away, Sloopy, Smart Recruiters, Smitten, Smogen III, Smooth Jazz, Sol y Luna, Solace, Solera, Solitaire, Solitude, Solstice, Sonamara, Song of the Sea, Sonrisa, Soozal, Sophia, Spanish Stroll, Spill Chaser, Spindrift, Spindrifter, Sprig, Sproyt, Stal Delphin, Star Fire, Star Passage, Starburst, Stardust, Starfinder, Still Searching, Stormfront, Story Maker, Story Seeker, Story Teller, Stowe Away, Sudestada, Sugar Magnolia, Suhaila, Sundance, Sunfish, Sunrise, Supreme, Swan, Swazik, Sweet As Bro, Sweet Grapes, Sweet Okole, Sweet Retreat, Sydney Marie, Synergizer, Taboo, Tahitiene, Tamure, Tango, Tantara, Tarquin, Taste of Honey, TaTanka, Tauri, Taz!!, Tembella, Temblor, Tempest, Tenacious, Tenacity, Tequa, Terrapin, The Dark Side, The Flying A, The Little Tom Thumb, The Lovely Martha, The Margo, The Persuasion, The Theory, The Tom Thumb, Thirsty, Thirty Birds, Ticker Tape, Ticket, Time Out, Time Warp, Tincup, Tip Sea, Tirrik, TNT, Tomboy, Tonopah, Tonto, Top Gallant, Top Kat, Total Simplicity, Toys R Us, Tradition, Traf-Lo, Trailer, Tranquility, Tranquilo, Traveler, Triple Crown, Trouble, True Colors, Truly Fair, Truth, Tsonokwis, TT Peter, Tuckaway, Tudo Bien, Turning Point, Tusitala, Twin Vee, Two Scoops, Two-Can, Tzigane, Unforgettable, Unity, USA 76, Valhalla, Valis, Valkyrie, Vanishing Animal, Veni Vidi Vici, Vento, Venture, Vesla, Vesper, Victoria II, Viking Lady, Virage, Vivace, Volare, Voyager, Walden, Wanda, Wanderbird, Wanderlust, Warp Speed, Warrior, Water Witch, Waterhorse, Wave Runner, Wellcraft, Westerly, Whale Rider, Whale Song, Whim Sea, Whisper, Why Knot, Why Not!, Wicked, Wicked Fun, Widgeon, Wildcat, Willanina, Willin', Willow, Wind Dancer, Wind FX, Wind Seeker, Wind Witch, Windborne, WindDancer, Windseafire, Windwalker, Windward Rhythms, Windward Star, Witch Doctor, Wizard, Wotalark, Yikes!, Yonder, Zephyr, Zingara II, Zinger, and last but not least, Zufreden.