

Latitude 38

# Latitude 38

VOLUME 425 November 2012

WE GO WHERE THE WIND BLOWS



NOVEMBER 2012

VOLUME 425

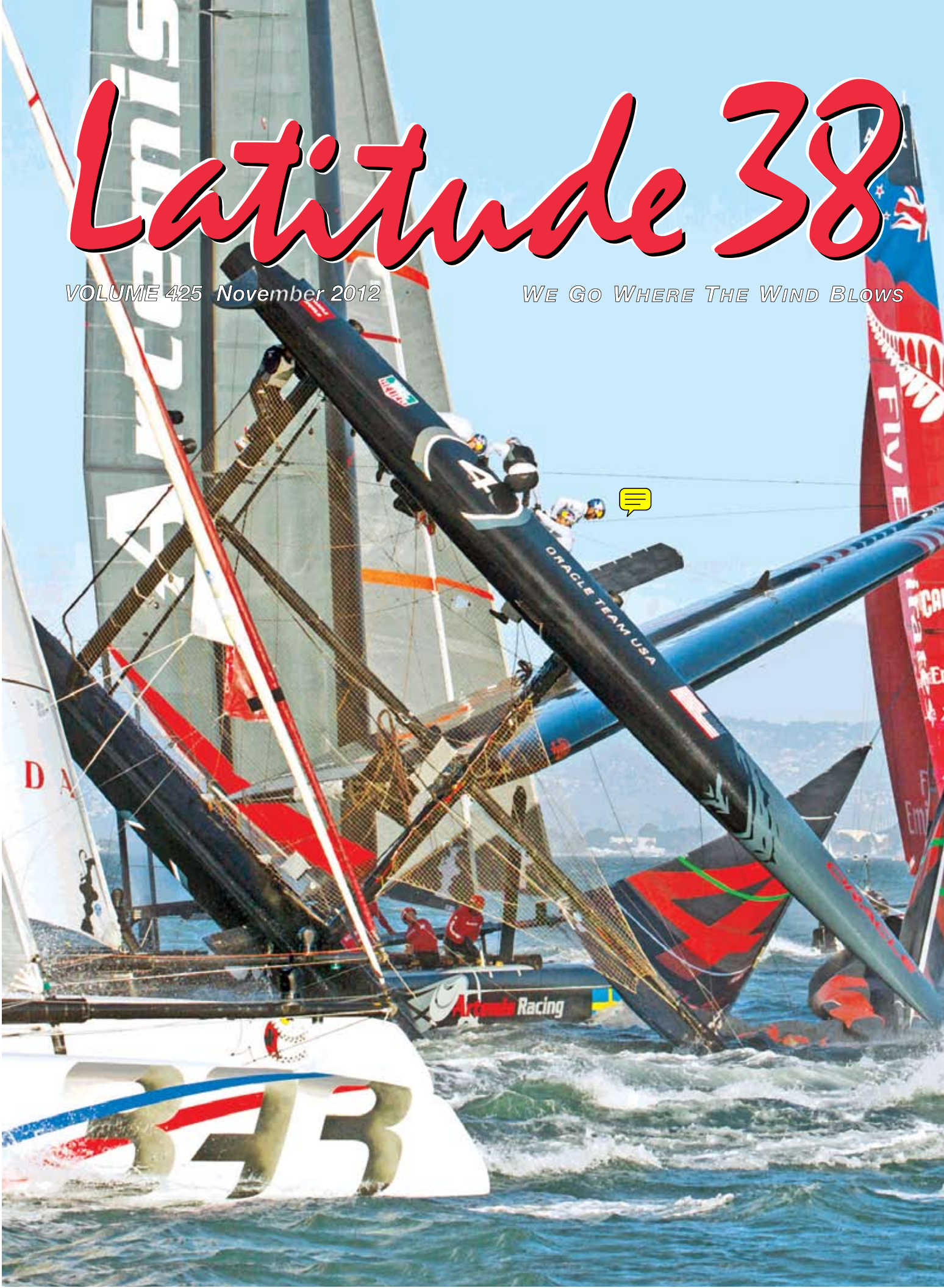



**25,000 SQUARE FEET OF  
THE FINEST CRAFTSMEN  
IN THE BUSINESS**

The Boatyard at Grand Marina • Marchal Sailmakers • UK-Halsey Sails  
Pacific Crest Canvas • Alameda Canvas and Coverings • Boats and Art  
Marine Lube • Arne Jonsson Boat Builders • New Era Yachts • Bay Island Yachts  
Pacific Yacht Imports • Bastress Custom Boat and Cabinet  
Mikkelson Custom Bike Frames • Alameda Marine Metal Fabrication  
Jeff van Klompenbuerg Yacht Maintenance • Boat Guys

And the newly expanded **Blue Pelican Marine Chandlery and Consignment** (3,500 square feet!)

*You can get it hauled, painted, lettered, gold leafed, covered, pounded, refit, rigged, reupholstered, sold, sailed, cleaned, polished, lubed, electrified, lit, coated, rebuilt, and more, literally ALL UNDER ONE ROOF. Come over and check us out!*

**GRAND MARINA – MORE THAN JUST  
A GREAT PLACE TO KEEP YOUR BOAT!**

- Over 400 concrete berths 30 to 60 feet
- Secured Gatehouses (electronic key system)
- Dockside Electrical (up to 50A - 220V)
- Cable TV & Telephone Service
- Heated & tiled restrooms  
with individual showers
- Beautifully Landscaped
- Ample Parking available
- Sailboat & Powerboat Brokers on site
- Excellent customer service
- Monthly informative newsletter

*We have a 100-ft liveaboard end-tie available!*

**DIRECTORY of  
GRAND MARINA  
TENANTS**

Blue Pelican Marine.....	140
Boat Yard at Grand Marina, The ..	21
Marchal Sailmakers .....	110
New Era Yachts .....	143
Pacific Crest Canvas.....	36
Alameda Marine Metal Fabrication	
Pacific Yacht Imports	
UK-Halsey Sailmakers	



**GRAND MARINA**

ANDERSON-ENCINAL

**(510) 865-1200**

Leasing Office Open Daily

2099 Grand Street, Alameda, CA 94501

[www.grandmarina.com](http://www.grandmarina.com)

# Time and Time Again

PHOTO ERIK SIMONSON/WWW.PRESSURE-DROP.US



***Santa Maria\****

Chris Giovacchini bought his first, and only, Santana 22, *Santa Maria*, in 1992. The boat was in full cruise mode, so Chris, intrigued by the prospect of racing the boat, began making changes, little by little, to switch to race mode.

He sold *Santa Maria* in 2002, in the hope of rekindling an out-of-state romance. But the romance “didn’t work out” and, sadly, his much loved “*Santa Maria* was gone.” Still, he kept track of the boat, all the while racing with other owners and even partnering with one. In 2009, Chris bought *Santa Maria* back from the then-owner and again made the transformation to race mode, this time taking an entire year to sand, streamline and prepare for the next season. The culmination of that preparation was the order of a class main and jib from Pineapple Sails.

Barely ready for the end of the 2010 season, *Santa Maria* “did okay in the last race” and came in second.

In 2011, Chris raced the full season and won. In 2012 he went for a repeat performance and was tied for first going into the last two races of the year. Again, he won the season.

As he puts it: All the while... Powered by Pineapples.

‘Tis the season. Give us a call.

YOUR DEALER FOR: Musto foul weather gear, Dubarry footwear and Headfoil 2

Sails in need of repair may be dropped off at:  
West Marine in Oakland, Alameda, or Richmond.

\*Powered by Pineapples



## **PINEAPPLE SAILS**

Phone (510) 522-2200

Fax (510) 522-7700

[www.pineapplesails.com](http://www.pineapplesails.com)

2526 Blanding Ave., Alameda, California 94501

# BOAT LOANS

from



Trident Funding

*"a fresh  
approach  
from people  
you can trust"*

In Northern California call  
**JOAN BURLEIGH**  
**(800) 690-7770**

In Southern California call  
**JEFF LONG**  
**(888) 883-8634**

[www.tridentfunding.com](http://www.tridentfunding.com)

## CONTENTS

subscriptions	6
calendar	8
letters	16
sightings	64
ac world series II	78
energy team on the rocks	84
jessica cup	88
baja ha-ha profiles, pt. III	92
max ebb: braving the weather	100
the racing sheet	104
world of chartering	112
changes in latitudes	116
classy classifieds	132
advertisers' index	141
brokerage	141

Cover: And this is just the little Team Oracle boat pitch poling!

Photo: ACEA/Gilles Martin-Raget

Copyright 2012 Latitude 38 Publishing, LLC

*Latitude 38* welcomes editorial contributions in the form of stories, anecdotes, photographs – anything but poems, please; we gotta draw the line somewhere. Articles with the best chance at publication must 1) pertain to a West Coast or universal sailing audience, 2) be accompanied by a variety of pertinent, in-focus digital images (preferable) or color or black and white prints with identification of all boats, situations and people therein; and 3) be legible. These days, we prefer to receive both text and photos electronically, but if you send by mail, anything you want back must be accompanied by a self-addressed, stamped envelope. **Submissions not accompanied by an SASE will not be returned.** We also advise that you not send original photographs or negatives unless we specifically request them; copies will work just fine. Notification time varies with our workload, but generally runs four to six weeks. Please don't contact us before then by phone or mail. Send all submissions to [editorial@latitude38.com](mailto:editorial@latitude38.com), or mail to Latitude 38 editorial department, 15 Locust Ave., Mill Valley, CA 94941. For more specific information, request writers' guidelines from the above address or see [www.latitude38.com/writers.html](http://www.latitude38.com/writers.html).

## SUPER VALUES!



Beneteau 40.7, 2001 \$165,000



Beneteau 393, 2003 \$134,500



Beneteau 40, 2009 \$199,000



Island Packet 31, 1988 \$59,500

### SAIL

51'	Beneteau Cyclades	2006	\$260,000
50'	Gulfstar	1977	139,500
46'	Beneteau Oceanis 461	1998	174,000
42'	Beneteau First 42	1985	89,500
41'	Tartan 4100	2004	345,000
41'	Beneteau 411	1999	148,500
41'	Dehler DS	1998	159,000
40'	Beneteau	2009	199,000
40'	Beneteau	2008	175,000
40'	Beneteau 40.7	2001	165,000
39'	Beneteau 393	2003	134,500
38'	Island Packet 380	1999	229,000
38'	Island Packet 380	1999	227,000
38'	Beneteau Moorings	1991	42,000
38'	Ericson 38-200	1988	68,000
37'	Island Packet 370 cutter	2004	269,900
37'	Pacific Seacraft yawl	1984	119,000
36'	Hunter sloop	2004	94,500
36'	Beneteau 361	2000	89,900
36'	Catalina	1989	49,900
36'	Pearson 36-II	1985	57,900
34'	C&B Marine Tiffany Jayne	1982	29,000
33'	Beneteau 331	2004	89,300
33'	Hunter 33.5 sloop	1992	39,500
32'	Beneteau 323	2007	93,500
32'	Beneteau 323	2007	89,500
32'	J/32	1997	79,000
32'	West sail	1976	64,400
32'	Freedom	1976	47,500
31'	Island Packet	1988	59,500
28'	Alerion Express	2002	74,500
28'	Catalina MkII	2002	49,900
24'	Corsair Sprint 750	2008	55,000

### POWER

61'	Mikelson SFPH	2002	990,000
53'	Navigator CPMY	1998	249,000
31'	Tung Hwa sedan trawler	1981	35,000

2 Bay Area Offices  
List with Us for Results

1220 Brickyard Cove Rd  
Pt. Richmond, CA  
(510) 236-2633  
www.passageyachts.com

## BENETEAU OCEANIS 45



## Beneteau Oceanis 45

Another new Oceanis 45 arrives this month and is ready for delivery!

- Revolutionary hard chine hull design
- Large convertible swim platform
- CE – all oceans rating
- Interior designed by Nauta – mega-yacht features and beauty, not mega-yacht pricing
- Named BEST FAMILY CRUISER for 2012
- Targa bar above the companionway keeps clutter out of the cockpit and improves main's sheeting angle
- Wide and gently descending companionway steps
- Large, well-organized cockpit

## BENETEAU OCEANIS 37



OCEANIS 31 34 37  
LIMITED EDITION. UNLIMITED POSSIBILITIES.  
SAVE UP TO \$14,000  
CALL FOR MORE POSSIBILITIES



For a limited time, we are offering the Limited Edition 31, 34 and 37 Oceanis sailboats with an impressive list of features including full Simrad electronics, autopilot, windlass, Window Grey hull color, Jenna galley counter-tops, Ultrasuede cushions and more.

Stop by our docks to view the 37 and take advantage of this incredible offer.

Beneteau Oceanis 25 31 34 37 41 45 50 54 58 First 30 35 40 45

OPEN BOAT WEEKEND in ALAMEDA ■ November 10-11



1070 Marina Village Pkwy  
Suite #101  
Alameda, CA  
(510) 864-3000

BENETEAU ISLAND PACKET ALERION SWIFT TRAWLER BROKERAGE

# Gori propeller

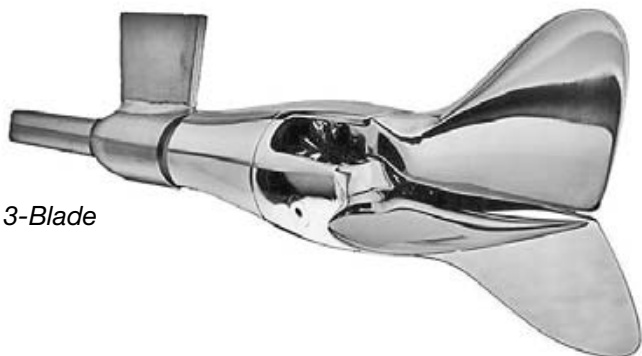

3-Blade

- For shafts and saildrives
- Both 2 & 3 blade available
- Lowest drag when sailing
- The champions choice



747 Aquidneck Ave.  
Middletown, RI 02842

**401-847-7960**

Fax: 401-849-0631

sales@ab-marine.com

[www.ab-marine.com](http://www.ab-marine.com)

**CALL US TODAY!**  
**800-801-8922**

## SHAFT SHARK

*The best rope,  
line and debris  
cutter there is!*

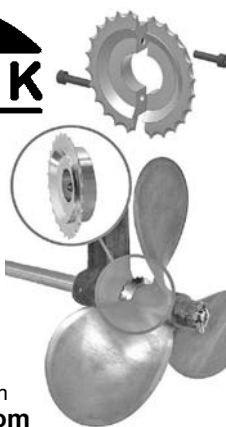

**401-847-7960**  
sales@ab-marine.com  
[www.ab-marine.com](http://www.ab-marine.com)

## Navisafe Navi Light 360°

Dinghy & Emergency Lighting from Navisafe



The new Navi Light 360° is a cost-effective, super bright LED light that is visible in darkness from up to 5nm. Its high burn time, small size, waterproof qualities and ability to float make it a convenient and cost-effective addition to any cruiser's arsenal!



**401-847-7960**  
sales@ab-marine.com  
[www.ab-marine.com](http://www.ab-marine.com)

# SUBSCRIPTIONS

**YOU CAN ALSO GO TO [www.latitude38.com](http://www.latitude38.com) TO PAY FOR YOUR SUBSCRIPTION ONLINE**

eBooks email list. *Free!*

See [www.latitude38.com](http://www.latitude38.com) to download the entire magazine for free! Our eBooks are in PDF format, easy to use with Adobe Reader, and also available in Issuu format.

Email: \_\_\_\_\_

*Please allow 4-6 weeks to process changes/additions, plus delivery time.*

Enclosed \$36 for one year Third Class Postage (Delivery time 2-3 weeks; Postal Service will not forward third class; make address changes with us in writing.)

Enclosed \$55 for one year First Class Postage (Delivery time 2-3 days.)

Third Class Renewal     First Class Renewal *(current subs. only!)*

Gift Subscription    Card to read from: \_\_\_\_\_

*NOTE: FPO/APO (military), Canada, Mexico, and subscriptions going to a correctional facility are first class only. Sorry, no foreign subscriptions.*

Name \_\_\_\_\_

Address \_\_\_\_\_

City \_\_\_\_\_ State \_\_\_\_\_ Zip \_\_\_\_\_

Phone: (    ) \_\_\_\_\_ Email: \_\_\_\_\_

**CREDIT CARD INFORMATION**     MASTERCARD     VISA     AMERICAN EXPRESS  
**Min. Charge \$12**    Number: \_\_\_\_\_ Exp.: \_\_\_\_\_ csv: \_\_\_\_\_

**INDIVIDUAL ISSUE ORDERS**     Current issue = \$6 ea.

Back Issues = \$7 ea.    MONTH/YEAR: \_\_\_\_\_

### DISTRIBUTION

We have a marine-oriented business/yacht club in California which will distribute copies of *Latitude 38*. (Please fill out your name and address and mail it to the address below. Distribution will be supplied upon approval.)

Please send me further information for distribution outside California

Business Name \_\_\_\_\_ Type of Business \_\_\_\_\_

Address \_\_\_\_\_

City \_\_\_\_\_ State \_\_\_\_\_ Zip \_\_\_\_\_

County \_\_\_\_\_ Phone Number \_\_\_\_\_

# Latitude 38

*"we go where the wind blows"*

Publisher/Exec. Editor ..... Richard Spindler ..... richard@latitude38.com  
Associate Publisher..... John Arndt..... john@latitude38.com ..... ext. 108  
Managing Editor ..... Andy Turpin ..... andy@latitude38.com ..... ext. 112  
Editor..... LaDonna Bubak..... ladonna@latitude38.com ..... ext. 109  
Racing Desk ..... racing@latitude38.com ..... ext. 105  
Contributing Editors ..... John Riise, Paul Kamen  
Advertising Sales ..... John Arndt..... john@latitude38.com ..... ext. 108  
Advertising Sales ..... Mike Zwiebach ..... mikez@latitude38.com ..... ext. 107  
General Manager ..... Colleen Levine ..... colleen@latitude38.com ..... ext. 102  
Production/Web ..... Christine Weaver ..... chris@latitude38.com ..... ext. 103  
Production/Photos..... Annie Bates-Winship ..... annie@latitude38.com ..... ext. 106  
Bookkeeping..... Penny Clayton..... penny@latitude38.com ..... ext. 101

Directions to our office..... press 4  
Subscriptions..... press 1,4  
Classifieds ..... class@latitude38.com ..... press 1,1  
Distribution ..... distribution@latitude38.com ..... press 1,5  
Editorial ..... editorial@latitude38.com ..... press 1,6  
Calendar ..... calendar@latitude38.com  
Other email..... general@latitude38.com



[www.latitude38.com](http://www.latitude38.com)  
15 Locust Avenue, Mill Valley, CA 94941  
Ph: (415) 383-8200 Fax: (415) 383-5816



**COME SEE THE NEW  
2 CABIN / 2 HEAD  
2013 JEANNEAU 409  
AT OUR DOCKS!**

**Dealer for Jeanneau, Marlow-Hunter & Grand Soleil Yachts**  
See over 100 new and used yacht listings at [www.CruisingYachts.net](http://www.CruisingYachts.net)



**2013 JEANNEAU 409  
IN STOCK!**



**2013 JEANNEAU 509  
IN STOCK!**



**2008 JEANNEAU 39i  
Asking \$187,000**



**2009 JEANNEAU 44i  
Perf. Version \$327,000**



**2000 CATALINA 42  
Listed at \$149,900**



**1991 HUNTER 42 CC  
Listed at \$110,000**



**2007 CATALINA 42  
Offered at \$199,900**



**2005 HUNTER 41DS  
Reduced \$172,000**



**2000 MOODY 42CC  
Reduced \$189,500**



**1979 MARAMU 46  
Listed at \$169,700**



**2005 JEANNEAU 49  
Offered at \$269,000**



**2008 HUNTER 45 CC  
Reduced \$259,000**



**2002 HUNTER 380  
New Listing \$102,500**



**2003 HUNTER 356  
Offered at \$87,500**

**California's largest used yacht broker with 5 waterfront locations.**

**San Diego  
(619) 681-0633**

**Alameda  
(510) 521-1327**

**Marina del Rey  
(310) 822-9400**

**Newport Beach  
(949) 650-7245**

**Oxnard  
(805) 791-2082**

**WWW.CRUIISINGYACHTS.NET**

## Don't leave port without 'em



Whether you  
never leave  
your boat...

...or must leave  
your boat to sail  
without you!



Matt Rutherford sailed non-stop around the Americas via the NW Passage and Cape Horn: 10 months never off his Vega 27! "The good news is my Monitor Windvane is still steering like a champ," said Matt. "I've put 50,000 miles on that windvane."



Derk Wolmuth was evacuated from his Vindo 40, *Bela Bartok*, due to a medical emergency while enroute to Hawaii. His Monitor Windvane steered the unmanned boat (and home) for 4.5 days until it was safely rescued 12 miles off Hawaii. Read more in the **NEWS** section of our website:

Call today and  
find out how a  
Monitor fits  
**YOUR** boat!



We can supply the RIGHT Windvane/  
Emergency rudder **FACTORY DIRECT**



**510.215.2010 • 888.946.3826**  
**scanmar@selfsteer.com**  
**www.selfsteer.com**

## CALENDAR

### Non-Race

**Oct. 29-Nov. 8** — Baja Ha-Ha XIX Cruisers Rally, from San Diego to Cabo San Lucas. Info, [www.baja-haha.com](http://www.baja-haha.com).

**Nov. 1** — Downwind Marine's Evening Cruisers' Seminar Series kicks off with 'Intro to Offshore Communication' by Shea Weston, 6-8 p.m., \$3. More seminars at same time and location. **11/6**: Planning for Cruising (Capt. Ann Kinner); **11/8**: Cruising on 12 Volts (Barry Kessler); **11/13 & 11/15**: TBA (check website). Info, [www.downwindmarine.com](http://www.downwindmarine.com).

**Nov. 1-Dec 6** — *Lady Washington* and *Hawaiian Chieftain* come and go in the Bay Area. For dates, times and details on tours or booking passage, see [www.historicalseaport.org](http://www.historicalseaport.org).

**Nov. 3** — Cruisers' Kick-Off Potluck at Downwind Marine in San Diego, 12-4 p.m. Info, [www.downwindmarine.com](http://www.downwindmarine.com).

**Nov. 4** — Daylight Saving Time ends.

**Nov. 4** — Cal Sailing Club's free introductory sail at Berkeley Marina, 1-4 p.m. Info, [www.cal-sailing.org](http://www.cal-sailing.org).

**Nov. 4** — US Sailing Club Judge Seminar at OCSC in Berkeley, 9 a.m.-6 p.m. \$65 (\$110 non-member). Registration required at [http://raceadmin.ussailing.org/Judges/Judges\\_Program/Club\\_Judge.htm](http://raceadmin.ussailing.org/Judges/Judges_Program/Club_Judge.htm).

**Nov. 4-25** — Free sailing at Pier 40 every Sunday courtesy of BAADS. Info, (415) 281-0212 or [www.baads.org](http://www.baads.org).

**Nov. 7-11** — Napa Valley Film Festival, featuring a special screening of *The America's Cup: 150 Years in the Making*. Info, [www.napavalleyfilmfest.org](http://www.napavalleyfilmfest.org).

**Nov. 7-28** — Wednesday Yachting Luncheon Series at St. Francis YC, 12-2 p.m. Enjoy lunch and a dynamic speaker each Wednesday for about \$25. All YCs' members welcome. More info under the 'Events' tab at [www.stfyc.com](http://www.stfyc.com).

**Nov. 8** — Are you a single boatowner and need crew? The Single Sailors Association has crew to help sail your boat. Monthly meeting at Ballena Bay YC in Alameda, 6:30 p.m. Info, [www.singlesailors.org](http://www.singlesailors.org) or (510) 239-7245.

**Nov. 10 & 17** — Sail aboard San Francisco Maritime National Historic Park's scow schooner *Alma*. Learn the Bay's history on this 3-hour voyage, leaving Hyde St. Pier at 1 p.m. \$40 adults, \$20 kids 6-15. Info, [www.nps.gov/safr](http://www.nps.gov/safr).

**Nov. 10-11** — ISAF Sea Survival course at San Francisco YC. Fee \$240. Fulfills Pacific Cup requirements. Repeats **11/17-18**. Email [amperrin@racingyachtmanagement.com](mailto:amperrin@racingyachtmanagement.com) for more info.

**Nov. 11** — Take a veteran sailing!

**Nov. 14** — 'Going Cruising? Know Before You Go' presentation by cruising consultant Neal Doten at Corinthian YC, 6:30 p.m. Free. RSVP at [www.cyc.org](http://www.cyc.org) or call (415) 435-4771.

**Nov. 15** — Boatrides & Barbecue fundraiser for Sausalito Community Boating Center (Cass Gidley Marina) at Dunphy Park, 4:30-6:30 p.m. Free boatrides, BBQ and live music. Donations welcome. Info, [www.cassgidley.org](http://www.cassgidley.org).

**Nov. 17** — SF Maritime's Sea Music Concert Series concludes aboard *Balclutha* at Hyde St. Pier, 8-10 p.m. \$14. Info, [www.maritime.org](http://www.maritime.org) or (415) 561-6662.

**Nov. 19-21** — Radial Clinic with NA champ Isabella Bertold & Christine Neville at Richmond YC. \$350. BYOB(oat) or email for charter. Info, [chrisnev@gmail.com](mailto:chrisnev@gmail.com).

**Nov. 20** — La Paz Beach Party at La Costa Restaurant, 4-7 p.m. Free for first 50 Ha-Ha'ers; everyone welcome.

**Nov. 22** — Work off all that turkey and pumpkin pie on a hearty Thanksgiving daysail with the family.

**Nov. 22** — Thanksgiving Cruiser Party hosted by El Cid Marina at Plaza Machado in Mazatlan, 5-8 p.m. Tickets \$25. Info, [marinaelcidmazatlan@elcid.com.mx](mailto:marinaelcidmazatlan@elcid.com.mx).

**Nov. 28** — Sail under the full moon on hump day.



# FARALLONE YACHT SALES



*Bella Barca, a 2012 Catalina 445, lingers at Potato Slough, Summer 2012.*



We're the proud dealer of Catalina and Tartan Sailing Yachts, and trailerable Ranger Tugs – all Made in America brands. Please visit [www.faralloneyachts.com](http://www.faralloneyachts.com) for details.



**OPEN BOAT WEEKEND NOVEMBER 10 & 11 ~ FINALIZE YOUR DREAM!**



1982 TAYANA 37 Cutter *Sunseeker* \$77,000



2013 RANGER 29 Trailerable Tug \$229,937 base price



2006 CHAPARRAL 3100 *Fanautical* \$89,900

### Preowned Catalina Yachts at Our Docks

Catalina 470, 2005 .....	\$327,000
Catalina 470, 1999 .....	<b>MOTIVATED SELLER!</b> 170,000
Catalina Morgan 440, 2006.....	259,900
Catalina 42 MkII, 2004.....	195,000
Catalina 42, 1989 .....	<b>MOTIVATED SELLER!</b> 89,000
Catalina 400, 2004 .....	<b>SOLD!</b>
Catalina 400, 2001 .....	<b>REDUCED!</b> 168,000
Catalina 380, 2000 .....	<b>REDUCED!</b> 136,000
Catalina Morgan 38, 1994.....	<b>REDUCED!</b> 108,000
Catalina 36 MkII, 2001 .....	98,500
Catalina 36, 1999 .....	<b>REDUCED!</b> 82,500
Catalina 36, 1995 .....	75,000
Catalina 36, 1984 .....	<b>NEW LISTING!</b> 49,500
Catalina 36, 1983 .....	<b>REDUCED!</b> 51,900
Catalina 350, 2005 .....	129,900
Catalina 350, 2003 .....	116,500

Catalina 34, 2003 .....	95,000
Catalina 34, 1990 .....	<b>NEW LISTING!</b> 47,500
Catalina 34, 1987 .....	<b>REDUCED!</b> 49,000
Catalina 34, 1989 .....	47,500
Catalina 34, 1987 .....	<b>SOLD!</b>
Catalina 320, 2000 .....	78,000
Catalina 310, 2000 .....	<b>NEW LISTING!</b> 79,000
Catalina 310, 2000 .....	59,000
Catalina 30, 1995 .....	<b>SOLD!</b>
Catalina 30, 1988 .....	<b>NEW LISTING!</b> 34,000
Catalina 30, 1984 .....	<b>REDUCED!</b> 22,000

### Preowned Sailing Yachts at Our Docks

Gulfstar 50 owners' model, 1978 .....	125,000
Beneteau 473, 2006 .....	288,500
Norseman 447, 1984 .....	199,000
Tartan 4100, 2004 .....	345,000
C&C 38, 1979 .....	<b>REDUCED!</b> 41,000
Tayana 37 Cutter .....	<b>NEW LISTING!</b> 77,000
Hunter 37, 1987 .....	49,000

Hunter 356, 2003 .....	<b>REDUCED!</b> 84,995
Islander 36, 1979.....	<b>SOLD!</b>
Santa Cruz 33, 1978 .....	35,000
Hunter 31, 2007 .....	<b>REDUCED!</b> 75,000

### New Ranger Tugs (base price)

Ranger 31 Tug, 2013 .....	<b>NEW MODEL YEAR!</b> 279,937
Ranger 29 Tug, 2013 .....	<b>NEW MODEL YEAR!</b> 229,937
Ranger 27 Tug, 2012 .....	159,937
Ranger 21EC Tug, 2011 .....	<b>LOADED!</b> 49,937

### Preowned Ranger Tugs at Our Docks

Ranger 29 Tug, 2010 .....	<b>NEW LISTING!</b> 189,900
Ranger 25SC Tug, 2010 .....	<b>INCLUDES TRAILER!</b> 125,000
Ranger 25 Tug, 2008 .....	120,000
Ranger 21EC Tug, 2009 .....	47,500
Ranger 21EC Tug, 2006 .....	<b>NEW LISTING!</b> 39,950

### Preowned Power Yachts

Cheoy Lee 66 Ocean Trawler, 1987 .....	<b>REDUCED!</b> 499,000
Ocean Alexander 44 .....	<b>NEW LISTING!</b> 165,000
Chaparral 3100, 2006 .....	89,900



1070 Marina Village Pkwy  
Alameda, CA 94501  
(510) 523-6730

2801 West Coast Hwy  
Newport Beach, CA 92663  
(949) 610-7190

From San Diego, CA  
Call  
(619) 523-6730

# WE'VE GOT YOU COVERED!

42-ft Covered Slips  
Now Available



Come tour our open slips and reserve now for winter and summer 2013.

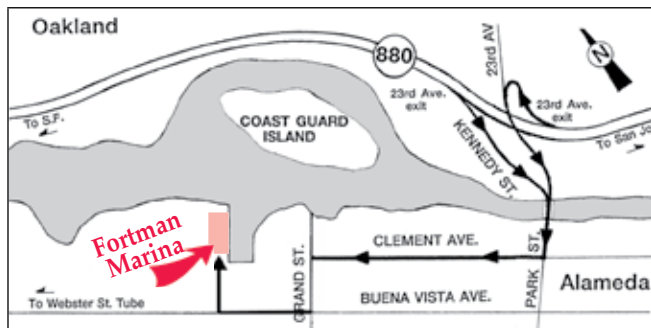

- Sheltered Alameda Location
- Competitive Rates
- Home of the Alameda Yacht Club

1535 Buena Vista Ave., Alameda, California  
(510) 522-9080

For directions and rates go to:  
[www.fortman.com](http://www.fortman.com)

## CALENDAR

**Nov. 29** — Angel Lights Countdown Benefit, a fundraiser for the Angel Island Conservancy, at a private Mill Valley home, 6-9 p.m. \$250. Info, [www.angelisland.org/angellights](http://www.angelisland.org/angellights).

**Nov. 1982** — It Was Thirty Years Ago from the *Sightings* article 'A Real Boon for Yachtsmen' by Glendda Chui:

Mike Lacey has seen it all — the "Flying Dutchman" boat that sailed 40 feet into the air, the attempted murder, the earthquake that rang a bell. But that's all over now. A new bridge has opened across the southern end of San Francisco Bay, the old Dumbarton Bridge is closed and Lacey, a drawbridge tender for 22 years, is out of work.

"You feel like you lost something," said Lacey, 66, as he sipped a Coors in the kitchen of his two-bedroom cabin in Sunol.

But one man's loss is another man's gain, said Bob Halligan, a spokesman for the State Department of Transportation, which built the new bridge and is tearing down the old one.

"This will be a real boon for yachtsmen," Halligan said. "That thing has been getting in their way for years."

The old Dumbarton Bridge has been a landmark since it opened in 1927, the first bridge to carry cars across the Bay. It stretches from Newark to East Palo Alto, clearing the water by nine feet at the main shipping channel. The drawbridge over the channel was lifted two or three times a day to a maximum height of 135 feet to make room for million-gallon fuel barges headed for Moffett Field and sailboats bound for the Gate.

One sailboat, known to the bridge tenders as the "Flying Dutchman," became something of a legend a few years back. The skipper and his son were approaching the Dumbarton from the south when they saw the drawbridge rise and decided to slip on through.

To their horror, the bridge dropped while they were directly underneath. They figured the mast would be snapped like a toothpick.

Just as the bridge touched the top of the mast, it hesitated, stopped and started back up — taking the boat with it. A stay or shroud had caught on the lip of a bolt on the underside of the bridge.

As the boat precariously rose 40 feet into the air, the father and son argued the merits of diving off into the Bay. "The son was prayin' and the old man was cussin'," Lacey said with a chuckle.

Meanwhile, a woman whose car was stopped on the bridge climbed up the metal trusswork, frantically shouting and waving at the lift operator, who was waiting for the boat to emerge on the other side and wondering what was taking it so long.

Finally the drawbridge was lowered. When the boat was a foot above the water, the wire that was caught on the bolt snapped. The boat plopped down, bobbed a bit and sailed on to San Leandro.

Lacey and the other drawbridge operators worked in a cramped, lonely office on the drawbridge, just above the roadway. Between lifts, they maintained the 120-hp gas engine, greased the bridgeworks, looked at TV and watched seagulls swoop down to steal fish from seals.

The new Dumbarton, \$180 million worth of stark, graceful concrete with 85 feet of clearance at the shipping channel, was opened on October 6. The old drawbridge was permanently raised. The steel trestle part of the bridge, about a quarter of a mile long, will be dynamited early next year, Halligan said, and the old access roads will be turned into fishing piers.

Lacey says he's kind of sorry to see it go. "I wouldn't spend all that money. That bridge there would last another 50 years."

**Dec. 1** — 36th Annual Lighted Yacht Parade on the Oak-

# Cityyachts



San Francisco's Yacht Broker

43 Years of Experience and Knowledge



46' Beneteau 45f5, 1993  
\$157,000



42' Catalina 42-3, 1989  
\$97,000



40' Hinckley Bermuda  
MkII CB, 1968  
\$119,000



40' Farr, 1992  
50-ft S.F. Berth



39' Cal MkII, 1979  
\$49,000



37' Tayana Cutter, 1977  
\$59,000



37' Pacific Seacraft, 1980  
\$109,000



40' Caliber 40 LRC, 1998  
\$189,500



36' Catalina, 1986  
\$45,000



32' Westsail, 1977  
\$49,000



30' Cape Dory Cutter, 1982  
\$39,500



30' Albin Ballad, 1978  
\$25,000



33' Nauticat, 1987  
\$79,995



41' Storebro SRC 400, 1990  
\$169,000  
Call about SF Giants special



39' Sea Ray 390, 1985  
\$195,000



34' Legacy, 2003  
\$270,000

10 MARINA BLVD., SAN FRANCISCO, CA 94123 • Toll Free: 877-444-5091 • 415-567-8880  
FAX (415) 567-6725 • email: sales@citysf.com • website: www.citysf.com

PLEASE VISIT OUR FUEL DOCK AT GASHOUSE COVE MARINA • OPEN 7 DAYS A WEEK • 9AM TO 5PM

# NEW J/70



Step up to a new level of performance with a J/Boat.

# J/111



Come see the J/70 and J/111, plus a fantastic selection of brokerage boats on our docks at Marina Village Yacht Harbor in Alameda.

**SAIL** California

www.sailcal.com

Alameda  
(510) 523-8500  
norman@sailcal.com  
steve@sailcal.com  
teri@sailcal.com  
rod@sailcal.com

## CALENDAR

land/Alameda Estuary. Starts at 5:30 p.m. Presented by Encinal YC, Oakland YC and Marina Village Yacht Harbor. This year's theme is 'Lights, Camera, Action'. Find out more and enter your boat at [www.lightedyachtparade.com](http://www.lightedyachtparade.com).

**Dec. 1** — Vallejo YC Harbor Lighted Boat Parade. Info, [www.vyc.org](http://www.vyc.org) or (707) 643-1254.

**Dec. 1** — Stockton SC Lighted Boat Parade. Info, [www.stocktonsc.org](http://www.stocktonsc.org).

**Dec. 1** — Santa Cruz YC Lighted Boat Parade in the south harbor, 5:30 p.m. Info, [www.scyc.org](http://www.scyc.org).

**Dec. 8** — Sausalito Lighted Yacht Parade along the waterfront, 6 p.m. Info, [www.sausalitoyachtclub.org](http://www.sausalitoyachtclub.org).

### Racing

**Nov. 3** — Summer's Last Gasp. HMBYC, [www.hmbyc.org](http://www.hmbyc.org).

**Nov. 3** — Club Boat Series #17 & 18. StFYC, [www.stfyc.com](http://www.stfyc.com).

**Nov. 3** — Red Rock Race. TYC, [www.tyc.org](http://www.tyc.org).

**Nov. 3** — Commodore's Cup. CPYC, [www.cpyc.com](http://www.cpyc.com).

**Nov. 3 & 17** — Fall #5 & 6. SSC, [www.stocktonsc.org](http://www.stocktonsc.org).

**Nov. 3-4** — NorCal FJ Regatta. SCYC, [www.scyc.org](http://www.scyc.org).

**Nov. 3-4** — Perry Cup/Kelp Cup. MPYC, [www.mpyc.org](http://www.mpyc.org).

**Nov. 4** — Jack & Jill + 1, the woman-skipped triple-handed race on the Estuary. IYC, [www.iyc.org](http://www.iyc.org).

**Nov. 11** — Lake Washington's annual Turkey Shoot Regatta. LWSA, [www.lwsailing.org](http://www.lwsailing.org).

**Nov. 11** — Crew's Revenge. MPYC, [www.mpyc.org](http://www.mpyc.org).

**Nov. 13** — YRA Year End Awards Party at Berkeley YC, 7 p.m. Info, (415) 771-9500 or [www.yra.org](http://www.yra.org).

**Nov. 18** — Commodore's Challenge. IYC, [www.iyc.org](http://www.iyc.org).

**Nov. 23** — Wild Turkey Race. TYC, [www.tyc.org](http://www.tyc.org).

**Dec. 1** — Fall #7. SSC, [www.stocktonsc.org](http://www.stocktonsc.org).

**Dec. 1** — Perry Cup/Midwinter. MPYC, [www.mpyc.org](http://www.mpyc.org).

**Dec. 30** — Christmas Race. MPYC, [www.mpyc.org](http://www.mpyc.org).

### Midwinter Regattas

**BERKELEY YC** — Midwinters: 11/10-11, 12/8-9, 1/12-13, 2/9-10. Bobbi, (925) 939-9885 or [bobbi@ifcbat.com](mailto:bobbi@ifcbat.com).

**BERKELEY YC** — Chowder Races: Sundays through March except when it conflicts with above.

**CAL SAILING CLUB** — Year-round Sunday morning dinghy races, intraclub only, typically in Laser Bahias and JY15s. Info, [racing\\_chair@cal-sailing.org](mailto:racing_chair@cal-sailing.org).

**CORINTHIAN YC** — Midwinters: 1/19-20, 2/16-17. Michael, [racing@cyc.org](mailto:racing@cyc.org).

**ENCINAL YC** — Jack Frost Series: 11/17, 1/19, 2/16, 3/16. Info, [rearcommadore@encinal.org](mailto:rearcommadore@encinal.org).

**GOLDEN GATE YC** — Manuel Fagundes Seaweed Soup Series: 11/3, 12/1, 1/5, 2/2, 3/2. Info, (916) 215-4566 or [raceoffice@ggyc.com](mailto:raceoffice@ggyc.com).

**ISLAND YC** — Estuary Midwinters: 11/11, 12/9, 1/13, 2/10, 3/10. John, (510) 521-2980 or [iycracing@yahoo.com](mailto:iycracing@yahoo.com).

**OAKLAND YC** — Sunday Brunch Series: 1/13, 1/27, 2/10, 2/24, 3/10. Jim, [urrailmeat@yahoo.com](mailto:urrailmeat@yahoo.com).

**REGATTAPRO** — Winter One Design & IRC: 11/10, 12/8, 1/12, 2/9. Jeff, (415) 595-8364 or [jzarwell@regattapro.com](mailto:jzarwell@regattapro.com).

**RICHMOND YC** — Small Boat Midwinters: 12/2, 1/6, 2/3, 3/3. Opti Midwinters: 12/1, 1/5, 2/2, 3/2. Bob, [bbranstad@gmail.com](mailto:bbranstad@gmail.com).

**SANTA CRUZ YC** — Midwinters: 11/17, 12/15, remaining TBA. Info, (831) 425-0690.

**SANTA ROSA SC** — Winter Series: 11/11, 12/2. Info, [www.santarosasailingclub.org](http://www.santarosasailingclub.org).

# SAIL *California*

## POWER UP WITH SAIL CALIFORNIA

### ALAMEDA

1070 Marina Village Pkwy #108  
Alameda, CA 94501  
**(510) 523-8500**  
FAX (510) 522-0641

### SEATTLE

**SAIL NORTHWEST**  
7001 Seaview Ave. NW #140  
Seattle, WA 98117  
**(206) 286-1004**



**J/44, 1991, Phantom**  
Well equipped, race or cruise.  
Asking **\$239,000**



**J/111, 2011, Invisible Hand**  
Ready for Transpac 2013!  
Asking **\$319,000**



**Bakewell-White 50, 2002, Brisa**  
Cruise anywhere.  
Asking **\$615,000**



**Tayana 55, Samadhi V**  
Many recent upgrades.  
Asking **\$249,000**



**Silverton 351 Sedan Cruiser, 1999**  
*This Is It*  
Ready to go play?  
Asking **\$99,995**



**True North 38, 2002, Ricochet**  
This SUV of the sea is read  
for fun on the water.  
**\$184,900**



**Columbia 30 Sportboat, 2006**  
*Escudro*  
Lift keel. On trailer. Race ready.  
Asking **\$89,800**



**Pacific Seacraft 40, 1999**  
*DreamKeeper*  
Well equipped. Cruise anywhere.  
Asking **\$314,900**



**J/160, 2001, Mandalay**  
Cruise in ultimate luxury.  
Asking **\$579,000**



**J/120, 2002, Alchera**  
Don't miss this incredible deal! This  
boat is well equipped and beautifully  
maintained. **\$169,000**



**J/105s**  
We have 5 from  
**\$68,900**



**Aerodyne 38, 2003, Kira**  
Must see, totally tricked out for  
cruising. Asking **\$189,000**

55' Tayana CC, '88, <i>Samadhi V</i> .....	\$249,000	40' Farr, '97, <i>Far Niente</i> .....	\$170,000	34' MJM 34z, '05*.....	\$259,000
53' J/160, '01, <i>Mandalay</i> .....	\$579,000	40' Pacific Seacraft, '99, <i>DreamKeeper</i> .....	\$314,900	33' Synergy 1000, '99.....	\$59,000
52' Santa Cruz 52, '99, <i>Renegade</i> .....	\$495,000	39' Silverton 351 Sedan Cruiser, '99.....	\$99,995	33' Back Cove, '08.....	SOLD
52' TransPac w/IRC mods, '03, <i>Braveheart*</i> .....	\$395,000	39' Carroll Marine CM 1200, '95*.....	\$55,000	32' Catalina 320, '95*.....	\$52,000
50' Bakewell-White, '02, <i>Brisa</i> .....	\$615,000	38' True North 38, 2002, <i>Ricochet</i> .....	Reduced \$184,900	30' Columbia 30, '06, <i>Escudero</i> .....	Reduced \$89,800
48' J/145, Hull #9, '03*.....	\$675,000	38' Aerodyne 38, '03, <i>Kira</i> .....	\$189,000	30' J/30, '79*.....	\$26,000
48' C&C Landfall 48, '81, <i>Footloose</i> .....	\$159,995	38' Alerion, '07*.....	\$269,000	30' Peterson Half Ton*.....	\$14,900
48' 1D48, '96, <i>Chaya</i> .....	\$60,000	36' J/109, '03*.....	\$189,000	30' Scout 30, '80, <i>Zelda</i> .....	Reduced \$54,500
47' Valiant, '81, <i>Sunchase</i> .....	SOLD	36' J/36, <i>Dawn's Early Light</i> .....	SOLD	29' MJM 29z, '07*.....	\$269,000
45' Jeanneau Sun Odyssey, '08*.....	\$319,000	35' J/105, '92, <i>Vim</i> .....	Reduced \$75,000	28' J/28, '87*.....	\$32,000
44' J/44, '90, <i>Phantom</i> .....	\$239,000	35' J/105, '02, Hull #581, <i>Business Time</i> .....	Pending \$84,900	28' Alerion Express, '02*.....	\$59,500
43' J/130, '96*.....	\$184,000	35' J/105, '01, Hull #400, <i>Lulu</i> .....	\$105,000	26' J/80, '06, <i>J Hawk</i> .....	\$48,500
42' Beneteau 423, '07*.....	\$204,500	35' J/105, '00, Hull #355, <i>Whisper</i> .....	\$89,000	26' J/80, '01, <i>Nimbus</i> .....	SOLD
41' J/124, '06.....	SOLD	35' J/105, '00, Hull #347, <i>Bald Eagle</i> .....	SOLD	26' J/80, '00*.....	\$29,000
40' J/120, '02, <i>Alchera</i> .....	Reduced \$169,000	35' J/105, '99, <i>Life Is Good*</i> .....	\$68,900		
40' J/120, '98, <i>Jolly Mon</i> .....	\$165,000	35' J/35C, '91*.....	\$89,000		
40' J/120, '94*.....	\$149,000	34' J/34, '85, <i>The Zoo*</i> .....	\$29,900		

\* Denotes Seattle Boats

# SAIL *California*

www.sailcal.com

email: norman@sailcal.com, steve@sailcal.com, teri@sailcal.com, rod@sailcal.com

DEALERS FOR THESE FINE YACHTS:

*Santa Cruz*  
— YACHTS —

*SUMMIT*  
YACHTS

**J.**  
BOATS



# HOGIN SAILS



Locally Made & Handcrafted

*Our sails are USED offshore,  
not MADE offshore!*

## HOGIN SAILS

- New racing and cruising sails
- Roller furling conversions
- Repair and service
- Boom and canvas covers
- ATN spinnaker/genoa sleeves
- All sails manufactured at our Alameda loft

Call us today to discuss your sail inventory.

**510.523.4388**

1801-D Clement Avenue, Alameda, CA 94501  
sales@hoginsails.com • www.hoginsails.com

## CALENDAR

**SAUSALITO YC** — Sunday Midwinters: 11/4, 12/2, 1/6, 2/3, 3/3. Dave Borton, (415) 302-7084 or [race@sausalito-yachtclub.org](mailto:race@sausalito-yachtclub.org).

**SEQUOIA YC** — Winter Series: 11/3, 12/1, 1/26, 2/9, 3/16. Redwood Cup: 11/18, 12/16, 1/13, 2/3, 3/3. Info, [www.sequoiayc.org](http://www.sequoiayc.org).

**SOUTH BEACH YC** — Island Fever Midwinters: 11/17, 12/15, 1/19, 2/16, 3/16. Info, [www.southbeachyc.org](http://www.southbeachyc.org).

**TIBURONYC** — Midwinters: 1/12, 2/9, 3/9. Ian, [race@tyc.org](mailto:race@tyc.org).

**VALLEJO YC** — Tiny Robbins Midwinters: 11/3, 12/1, 1/5, 2/2, 3/2. Info, [www.vyc.org](http://www.vyc.org) or (707) 643-1254.

Please send your calendar items by the 10th of the month to [calendar@latitude38.com](mailto:calendar@latitude38.com). If you're totally old-school, mail them to *Latitude 38* (Attn: Calendar), 15 Locust Avenue, Mill Valley, CA, 94941 or fax them to us at (415) 383-5816. But please, no phone-ins! Calendar listings are for marine-related events that either are free or don't cost much to attend. The Calendar is not meant to support commercial enterprises.

### November Weekend Tides

date/day	time/ht. HIGH	time/ht. LOW	time/ht. HIGH	time/ht. LOW
11/03Sat	0405/4.4	0833/3.2	1421/5.3	2114/0.2
11/04Sun	0357/4.4	0831/3.3	1409/5.0	2103/0.3
	LOW	HIGH	LOW	HIGH
11/10Sat	0127/1.3	0811/5.9	1432/0.4	2100/4.6
11/11Sun	0214/1.5	0848/6.3	1516/-0.3	2200/4.8
	HIGH	LOW	HIGH	LOW
11/17Sat	0238/5.1	0720/2.7	1325/6.3	2010/-1.0
11/18Sun	0335/5.1	0832/2.7	1425/5.7	2107/-0.5
	LOW	HIGH	LOW	HIGH
11/22Thu	0002/1.0	0704/5.7	1327/1.2	1931/4.3
11/23Fri	0055/1.4	0745/5.9	1419/0.7	2041/4.3
11/24Sat	0144/1.8	0822/6.0	1503/0.2	2142/4.4
11/25Sun	0230/2.1	0855/6.0	1542/-0.1	2234/4.5

### November Weekend Currents

date/day	slack	max	slack	max
11/03Sat		0206/2.9F	0540	0744/1.9E
	1054 2351	1345/1.8F	1621	1953/3.9E
11/04Sun		0152/2.8F	0528	0733/1.8E
	1049 2339	1335/1.6F	1609	1942/3.6E
11/10Sat		0021/3.1E	0349	0649/3.1F
	0954 2245	1252/4.2E	1644	1935/3.3F
11/11Sun		0115/3.1E	0437	0734/3.3F
	1033 2344	1340/4.8E	1731	2027/3.8F
11/17Sat		0048/4.3F	0418	0629/2.5E
	0944 2238	1231/2.7F	1518	1839/5.1E
11/18Sun		0145/4.0F	0512	0727/2.5E
	1052 2335	1333/2.5F	1620	1936/4.5E
11/22Thu		0535/3.1F	0833	1140/3.3E
	1524	1822/2.6F	2104	2347/2.5E
11/23Fri		0625/3.0F	0917	1231/3.6E
	1617	1920/2.9F	2207	
11/24Sat		0048/2.3E	0408	0710/2.8F
	0958 2305	1313/3.9E	1705	2011/3.2F
11/25Sun		0139/2.2E	0454	0750/2.7F
	1037 2356	1351/4.1E	1748	2056/3.3F



# OWN A BIG PIECE OF SAN FRANCISCO SAILING

**The San Francisco Sailing Company  
and The San Francisco Sailing School  
are seeking qualified buyers**

The San Francisco Sailing Company & The San Francisco Sailing School  
located on San Francisco's busiest pier and tourist destination  
with an estimated 14 million visitors each year

✕  
The closest sailing school and charter company  
to the America's Cup Village

✕  
Consistent financial performance

✕  
Own the ultimate lifestyle business

✕  
Sailing experience recommended,  
but not required

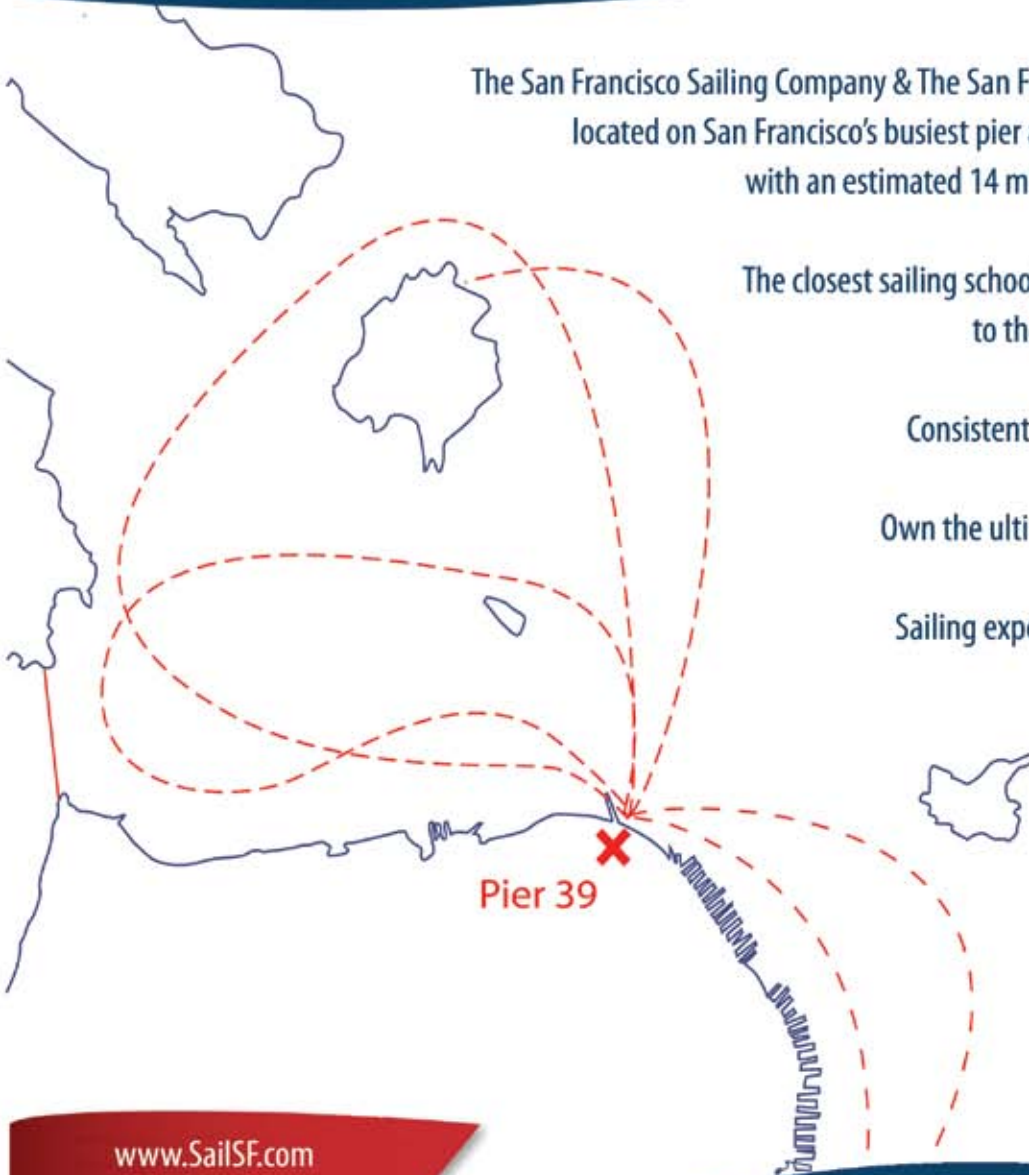

[www.SailSF.com](http://www.SailSF.com)  
[www.SailingLessonsSF.com](http://www.SailingLessonsSF.com)

Serious inquiries with proof of financing  
Contact: [Edward@SailSF.com](mailto:Edward@SailSF.com) or call: 415-601-0627

# Our Best Sailing Lesson Offer Ever!



You can skipper this sized boat!

**ONLY**  
**\$695**  
 for weekday package

**\$995**  
 for weekend package

#### Includes:

- Basic Keelboat Course
- Basic Cruising Course
- Bay Cruising Workshop
- 1 Year US Sailing Membership
- Club Nautique Membership
- All Course Materials
- US Sailing Certification to skipper boats up to 34'
- Classes in Alameda or Sausalito

**Call Today!**

Sausalito 800-559-CLUB  
 Alameda 800-343-SAIL

**Club Nautique**

You're at the helm!

[www.clubnautique.net](http://www.clubnautique.net)

## LETTERS

### ↑↓HELP ME HELP HER

Our time to start cruising is coming near, so my wife and I are spending more time reading *Latitude*, looking at boats in the Berkeley Marina, and watching *You Tube* videos about sailing. Come February, the two of us will be driving our VW bus to Miami to hopefully begin a new life at sea.

I'm a local from the Bay Area, but my wife is from Prague. It's taken me awhile to get her onboard with my dreams of



ADAM SCHEUER

**Adam has talked his wife into going cruising but seasickness is a real problem.**

sailing adventures, but she's way down with it now, and it seems as if the time of our lives is quite possibly just around the corner. There are just two assumptions. The first is that she finishes her final semester at Cal. The second, and potentially more troubling one, is that we find a way for her to get over her motion sickness.

My wife is very prone to seasickness. For example, she got motion sickness while sitting on the back of a water ski boat on Lake Tahoe on a super glassy day. She has a hard time with bus rides, and even my driving can give her nausea. The good news is that she doesn't have a problem when she's driving.

So maybe *Latitude* can answer our two questions: 1) Is it possible for someone who is "very allergic" to seasickness to overcome it; and, 2) what are the best methods for prevention and treatment?

Adam Scheuer  
 Berkeley

*Adam — As we're sure you know, motion sickness isn't an allergy, but rather confusion between the eyes' seeing a world that is still while the equilibrium sensors in the inner ear transmit signals saying that a person's environment is moving. In many people this confusion causes the body — to say nothing of the digestive system — to go into a state of alarm. As is the case with your wife, potential victims often feel better when they drive the car or the boat because there tends to be less internal confusion between what's being seen and what's being sensed.*

*We're not doctors, nor do we even play them on television, so the following information is just a starting point for a discussion with your wife's physician. There are countless so-called remedies for seasickness, from ginger to acupuncture wrist bands to prescription and non-prescription medicines. It's hard to tell what's going to work on any given person.*

*Based on anecdotal reports, the remedy we've heard to be the most effective is Cinnarizine/Stugeron, which is a prescription medicine in Canada, but is sold over-the-counter in Mexico and just about everywhere else in the world — except the States, where it's not available. Stugeron is an antihistamine that interferes with the signals between a person's inner ear and their 'vomiting center'.*

*As with all powerful drugs, you don't want to take Stugeron without discussing it with your doctor, and you must be careful with the dosage. If too much is taken, it can make a person drowsy. We're told that when this happens to members of the Coast Guard, they are given epinephrine as the second part of what's known as the 'Coast Guard Cocktail'. But again, don't*



# Get A **FREE** Polish & Wax With Any Bottom Job From **SVENDSEN'S**

Call to schedule your service: 510.522.2886 | or schedule online: [svendsens.com](http://svendsens.com)



The Bay Area's full-service boat yard since 1963, Svendsen's performs all aspects of marine repair on site, including the best bottom jobs on the Bay.



**SVENDSEN'S  
BOAT WORKS**

Boat Works	510.522.2886
Chandlery & Rig Shop	510-521-8454
Metal Works	510-864.7208
Dinghy & Trailer Sales	510-521-8454
General Inquiries	<a href="mailto:info@svendsens.com">info@svendsens.com</a>

1851 Clement Avenue, in the Alameda Marina  
[www.svendsens.com](http://www.svendsens.com)

Svendsen's is proud to use and  
distribute the full line of

**Sea  
Hawk**  
PREMIUM YACHT FINISHES



Premium Yacht Finishes



Outboard Engine Owners:

## WE UNDERSTAND

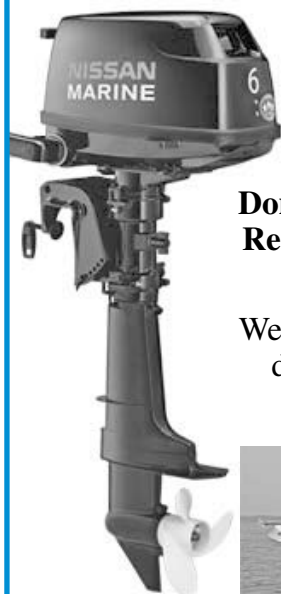

When an engine dies, there's no walking home – just costly repairs, lost vacation time, and lost revenues.

**Don't find yourself in this boat. Regular maintenance prevents expensive repairs.**

We are *your* experts for outboard diagnostics, repair, repower, sales and service.



- Factory-trained and certified techs
- Open six days a week
- New and used engines bought and sold
- One-year warranty on all work performed and used engine sales
- Three-year warranty on all new engines

## MARINE OUTBOARD

since 1990

OUTBOARD SALES, SERVICE, REPAIR, PARTS

**(415) 332-8020**

Nissan  
Tohatsu  
Johnson  
Evinrude



Honda  
Mariner  
Mercury  
Yamaha

35 Libertyship Way • Sausalito, CA 94965

Conveniently located at Libertyship Marina

*If we're not maintaining your outboard,  
you've missed the boat!*

## LETTERS

even dream of doing this without consulting your doctor, as epinephrine is another very powerful drug.

We rarely get seasick, so we're going to ask our more seasickness-prone readers for their experiences with the malady, and remedies that have worked or not worked for them. We wish your wife the best of luck, because as the old saying goes, there are only two states of being seasick: 1) Feeling as if you're going to die, and 2) wishing that you would die.

### ↑↓ NOT NECESSARILY A CAUSE FOR ALARM

After reading about Doña de Mallorca's very unpleasant experience with vertigo during the Redondo Beach stop in the SoCal Ta-Ta, I want her to know about a similar experience I had after being aboard for an extended period of time. My ear doctor, who sails a Hunter 36, immediately diagnosed me as having benign paroxysmal positional vertigo. He suggested that it might be related to the movement onboard a boat, and not a cause for alarm.

De Mallorca may have been able to avoid her trip to the emergency room if she had known this information. It might be good for the readers of your — fabulous! — magazine to know, too.

Ron McCarthy  
Surprise, Ericson 38  
San Diego

Ron — Thank you for your kind words and concern. The paramedics who responded to de Mallorca at the King Harbor YC were very familiar with vertigo. In fact, they even told her it was likely that's what she was suffering from, as opposed to much more serious possibilities such as a brain tumor or stroke. But because her vertigo was so severe — she could barely lie down let alone sit up — the paramedics felt they had no choice but to take her to the hospital where the possibilities of stroke and tumor could be eliminated. Even several hours after being given a medication — Bonine, a common seasickness treatment — de Mallorca was still too dizzy to even sit up. Twelve hours after the attack, she was exhausted but otherwise felt fine. And the doctor even cleared her for a sail to Catalina.

We're convinced that de Mallorca's vertigo had nothing to do with her having been on a boat, as it didn't come on until after she'd been ashore for an hour or more, and the vertigo hasn't returned despite her being on the boat almost full-time ever since.

De Mallorca would like to pass on the knowledge that vertigo is not at all uncommon, so if you experience it, try your best to remain calm, because chances are that it's not serious and it won't return. Nonetheless, if you're more than a little dizzy, you can't risk not being checked out immediately.

### ↑↓ THEFTS IN THE ESTUARY SURGE

There has been a rash of marine-related thefts in the Oakland Estuary area lately. Hearsay has it that somewhere between nine and 15 outboard motors were stolen from boats in just one Estuary marina. I know of at least two incidents of kayaks being stolen. And then, on September 18, my Monitor windvane was stolen off the dock next to my boat at Marina Village. I had removed it from my boat for service, and felt it would be safe on the dock overnight.

I've always found the boating community to be both trusting and trustworthy, so it's sad when a few lowlifes spoil it for everyone. Lots of fingers have been pointed toward the anchor-outs next to Coast Guard Island, but there is no proof that any of them have been involved.

Indeed, because of the different ways the thefts were carried



# YACHT BROKERAGE - SALES & SERVICE [WWW.JK3YACHTS.COM](http://WWW.JK3YACHTS.COM)

**SOLD, SOLD, SOLD - WE ARE LOOKING FOR MORE QUALITY LISTING, CALL US TODAY !**



2006 65' J/Boats J/65  
MAITRI \$1,979,000



2000 46' J/Boats J/46  
QUESTAR \$415,000



(2 avail) 2005 43' J/Boats J/133  
PALADIN & PICANTE \$350,000



2007 40' J/Boats J/124  
FORGIVENESS \$239,000



2008 40' King / Summit 40  
SOOZAL \$539,000



2000 40' SABRE 402  
CYGNUS **REDUCED** \$259,000



1999 40' J Boats J/120  
BLUEBIRD \$169,000



2004 36' Beneteau 36.7  
AY CALIENTE! \$118,000



2006 36' J/109  
LANUI \$199,000



2) 35' J/Boats J/105  
2002 KEALAIKAHIKI \$89,900  
2003 LUCKY STAR \$109,900



2007 36' Beneteau 10r  
LATITUDE 52 \$124,500



2013 48' SABRE 48se  
New Model Arrives December



2006 43' Oyster 43 LD  
VARUNA \$525,000



2005 40' Raider Aquapro RIB  
SURF RAIDER \$218,000

### SAIL.....

- 2000 42' J/42 - Reluctant \$209K
- 2001 40' C&C 121 \$210K
- 1993 38' Morgan 38 \$99K
- 2000 35' Tartan 3500 \$129K
- 2007 33' Cross Current \$179K
- 2001 32' J/32 - La Dolce **SOLD**
- 2001 32' J/32 - Betty **SOLD**
- 2000 32' J/32 - Rhapsody \$109K
- 2005 30' Columbia 30 \$60K

### POWER.....

- 2013 48' SABRE 48 se **Call**
- 2008 44' Renzo Coupe \$549K
- 2004 38' True North **SOLD**
- 2013 38' SABRE 38 se **Call**
- 2011 30' Back Cove 30 **SOLD**

### RIBS.....

- 2009 30' RAIDER RIB 9m \$69K

**San Diego: 619.224.6200 Newport: 949.675.8053 Alameda: 510.227.2100**

**DEALERS FOR:**



2013 SABRE 38 SE w/Pod Drives



All New 2013 J/70



2013 Hanse 415



2012 SABRE 426 MkII

**San Diego**  
Jeff Brown  
Jeff@jk3yachts.com  
619.709.0697

**San Diego**  
Kenyon Martin  
Kenyon@jk3yachts.com  
858.775.5937

**San Diego**  
Jack Lennox  
Jack@jk3yachts.com  
619.356.3881

**Newport Beach**  
Walter Johnson  
Walter@jk3yachts.com  
949.421.8006

**Newport Beach**  
Scott Poe  
Scott@jk3yachts.com  
714.335.2229

**Alameda**  
Art Ball  
Art@jk3yachts.com  
510.304.5286

**Alameda**  
Chris Corlett  
Chris@jk3yachts.com  
510.914.1073

# Find holiday gear here!



## We're geared up for the holidays with the gifts sailors really want!

You already know that nobody has more in store for your boat. And for the holidays, we have more great gifts for anyone who loves the water!

From stocking stuffers to marine stereos, find great boating gift ideas at your local West Marine store or online at [westmarine.com](http://westmarine.com).

### Can't Decide?

Gift cards • Available online and at all store locations • [westmarine.com/giftcards](http://westmarine.com/giftcards)



**West Marine**<sup>®</sup>  
For your life on the water<sup>™</sup>

Follow us on:



We have 17 stores in Northern California, including our Alameda Sailing Superstore!

Visit [www.westmarine.com](http://www.westmarine.com) to find the store nearest you.

## LETTERS

out, it seems there may be multiple thieves. For example, in the case of one of the kayak thefts, people were seen loading kayaks on top of a van in broad daylight, then hastily driving off. But I think my windvane was stolen in the middle of the night by someone in a dinghy. I live aboard my boat at Gate 11, and at about 3 a.m. I was awoken by the sound of a dinghy in the fairway behind my boat. I thought it was suspicious that someone would be motoring around at that hour, but as it was 3 a.m., I convinced myself that I was just being paranoid, and went back to sleep. I awoke to find my paranoia had been justified.

I immediately contacted the police, the harbormaster, and Scanmar, which makes the vanes and keeps a record of every one they sell. I also gave pictures and notices to Aaron Metals, the local recycler, and Blue Pelican, the local marine consignment shop. That weekend I looked for my vane at the swap meets in Emeryville and Martinez, and spread the word to the swap meet 'pros' to be on the lookout for it.

When I went to Aaron Metals to tell them about the theft, there was an Oakland Police Department patrol car in their parking lot. The police were there to investigate a break-in and theft that had occurred there the night before. It's gotten so bad that people are stealing scrap metal from recyclers! I know that a lot of folks are going through tough financial times, and some who would otherwise be honest are being pushed to the edge. But really, stealing isn't the right solution.

I assume my vane was sold as scrap metal for a pitiful \$20-\$30. However, as the theft coincided with cruisers' annual migration to Mexico, who knows, maybe it will show up on a boat or at a swap meet in Southern California or Mexico. I am offering a reward of \$1,000 to anyone providing information leading to the recovery of the vane. It is distinguishable by its serial number (6258-1299), by its missing vane clamping plate, which I had removed for service, and by a plastic arm that I installed to prevent the counterweight from swinging while at anchor. If anyone has information, please contact me at [jamesnhancock@hotmail.com](mailto:jamesnhancock@hotmail.com).

Jim Hancock  
Solstice, Freya 39  
Marina Village, Alameda

*Jim — We imagine it wouldn't surprise you to hear that there had been a big ring of outboard motor thieves operating in Long Beach. According to a story by Taylor Hill in the October 12-25 edition of The Log, "... 32 suspects have been identified in the organized thefts of numerous unlocked outboard engines from boats [in Long Beach's Shoreline Marina]. Thieves reportedly loaded the engines onto pallets and sold them in bundles for around \$10,000."*

*The article went on to report that the thieves — 15 of whom were already in custody — specialized in stealing small outboards that could be carried easily by hand. Since the bust, there hasn't been further outboard theft from the 1,764-slip marina.*

*In what we find to be a strange twist to the story, a federal grant was issued so that the Marine Bureau could purchase and distribute 3,000 engine locks to boatowners. What's next, the government providing homeowners with locks for the front doors of their homes?*

### ↑↓ ALSO KNOWN AS WHALENIP

In his September letter, Steve Efferheim asked for ways to alert whales while underway on a 'silent' sailing vessel. During numerous long-distance races from Southern California to Mexican ports such as Cabo San Lucas, Puerto Vallarta and

# JUST LAUNCHED

Your full service boat yard.



Home | Services | Rates

Gallery | Links | Green Yard

CLICK  
OUR  
RATES!



We're happy to  
share them.  
(No hidden charges!)

NEW WEBSITE:  
**www.boatyardgm.com**

We're just a 'click' away.

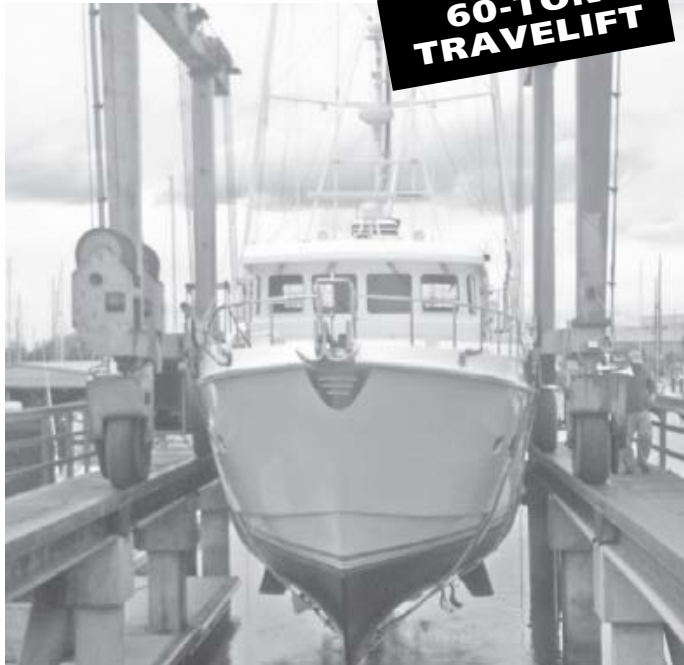

## CLEAN AND GREEN

Now – the latest in environmental  
filtration technology. Protecting you,  
our workers and the Bay.

## IT'S SIMPLE!

Call The Boat Yard at Grand Marina for the Lowest Bottom Prices!

~ COMPARE US WITH THE COMPETITION ~

- Prop and Shaft Work
- Mast & Rigging Repair
- Fiberglass & Blister Repair
- Gelcoat Repair
- Gas & Diesel Engine Service
- LPU Hull & Topside
- Electrical Repair & Installation

**Interlux**  
yachtpaint.com

**AWLGRIP**

**CALL FOR A RESERVATION**

(510) 521-6100 • Fax (510) 521-3684

2021 Alaska Packer Place, Alameda

FEATURING  
TRINIDAD  
ANTI-FOULING PAINT BY

**PETTIT**

Go clean into the future.

RATED "SUPERIOR" by Practical Sailor

# Engineered Apparel



## Great looking gear with performance built right in!

Every item of West Marine apparel is designed and built with boating in mind. From the architecture of each garment, to the most innovative technical fabrics and thoughtful construction detailing, these clothes are designed to work "out there" on the water. And the best part? Every garment is priced to deliver superior value. Visit us today, at our stores or at [westmarine.com](http://westmarine.com), and see for yourself!

 **West Marine**<sup>®</sup>  
For your life on the water<sup>™</sup>

We have 17 stores in Northern California, including our Alameda Sailing Superstore!  
Visit [www.westmarine.com](http://www.westmarine.com) to find the store nearest you.

## LETTERS

Manzanillo, we have had numerous close encounters with whales. Over time we noticed that turning our depthsounder on or off had a noticeable effect on whales. Some of them approached our 50-ft boat within a few feet when the sounder was on, and departed when we turned the instrument off.

I discussed some of these experiences with a marine mammal expert while on a whale watching trip along the coast of Maine. She explained that whales can detect sound waves emitted by the depthsounder's transducer. Experiments and observations showed that some whales actually rubbed themselves against large transducers installed at the bow of commercial vessels when the depth sounder was on.

It seems to me that turning a depth sounder on while sailing would alert whales. If they get too close, shut the depth sounder off!

Victor Beelik  
Zephyr Cove, NV

*Victor — Given the tremendous increase in the number of whales along the West Coast of North America, it would be nice if there were some scientific, rather than just anecdotal, data to support your hypothesis that depthsounder sound waves are catnip to cetaceans. But since there is nothing to lose when offshore, our plan is to leave our depthsounder off in deep water.*

### ↑↓"PLEASE HAVE A FATHERLY CHAT WITH ZACH"

At the closing ceremony of the '11 Baja Ha-Ha, the Grand Poobah awarded the Spirit of the Ha-Ha Award to Zach Lough and his Catalina 30 *Panache*. Since then, we have been following his adventures, which have been documented with beautiful photographs, at [sailpanache.com](http://sailpanache.com).

Zach recently completed his passage from Central America to French Polynesia via the Galapagos. On his blog he boasted about using Ham radio without a license, unsuccessfully sneaking into the Galapagos without checking in, and visiting Fatu Hiva before clearing into French Polynesia at Hiva Oa. I feel that this devil-may-care attitude of flouting authority should be discouraged. It makes the yachting life more difficult for the rest of us law-abiding cruisers.

I hope that you will have a 'fatherly' chat with Zach and help him return to being the young cruiser who is 'The Spirit of the Ha-Ha'.

Ned Backus  
Frannie B, Outbound 44  
Seattle, WA

'91-'99 Circumnavigation on Cal 39 *Plain Jane*

### ↑↓ZACH RESPONDS

I read the email from *Frannie B*, and I wanted to be sure everyone got my side of the story. I also want to thank *Frannie B* for following my blog and caring enough to comment.

While I understand where Ned is coming from — breaking FCC regulations is bad, and sneaking into a country is also bad — he needs to understand that I'm not some cavalier jackass thumbing my nose at authority. There is substantial context missing in his account, and I suspect he is misunderstanding my sarcastic tone.

I meant no disrespect. The portion of my blog post concerning the illegal use of the HF radio aboard *Panache* was an attempt to be funny by describing an honest — maybe silly — perspective of someone singlehanded across an ocean and then, five days into his crossing, being told he can no longer communicate with the outside world. It was a pretty grim feeling, and I challenge anyone to feel differently. Yes, I should have gotten my license, and yes, I had more than

# Discover the difference!

- ▶ Certified Quality
- ▶ Custom Sail Washing
- ▶ Expert Upgrades & Recuts
- ▶ 11 Point Sail Inspection
- ▶ Winter Sail Storage
- ▶ Pick up and Delivery

When it comes to sail care, *there is a difference!* All North Certified Sail Care follows North Manufacturing Blue Book quality standards for construction and materials... *even if your sail is not a North sail!* Now is the time to bring in your sails and sail covers for inspection, repairs, washing and upgrades.

**SAVE 20%**

*when you bring in your suit of sails for sail care. Hurry! Offer expires 12/31/2012.\**

\*Offer is limited to North Sails Sausalito location as is limited to boat size 50ft. LOA or less. Offer expires December 31, 2012. other limitations may apply.



*Better by Design*

**Sausalito**

415-339-3000

2730 Bridgeway, Sausalito, CA 94965

[www.northsails.com](http://www.northsails.com)

Rick Linkemyer photo

# Connection Perfection



Wing Clamp technology locks connections securely without threaded collars.



Built-in Cordlight helps you make connections—even in the dark!



Power Indicators at each end of the cord ensure safe, reliable connections.



## Marinco's new EEL Shorepower Cordsets ensure reliable dockside power

Water and electricity can be a tricky combination. Now Marinco, the leader in shorepower technology, has re-designed its shorepower cords to make them safer and more reliable than ever. And they're exclusively available at West Marine.

Available in 30 Amp and 50 Amp cordsets in lengths from 12 to 50 feet. Exclusively at West Marine stores or at [westmarine.com](http://westmarine.com).

Scan the QR code with your Smartphone to visit [westmarine.com](http://westmarine.com) and find the store nearest you.

To scan a QR code, first download a free QR code reader app.



Follow us on:



**West Marine**  
For your life on the water™

Visit our stores! For the location nearest you, or to shop 24/7, go to [www.westmarine.com](http://www.westmarine.com)

## LETTERS

enough time. I admit both these facts on my blog.

"Tried to forward my position using the Maritime Mobile net, 14.300 USB, and was ousted as a non-licensed user." Yeah, I don't have a license, but I am a singlehanded sailor who relies on other people's knowledge of my position as insurance against worst-case scenarios. Sure, I can transmit if I have an emergency, but what if my emergency rendered me unconscious, or what if my radio were damaged? I understand the rules, but I saw myself as an exception. I am professional when using the radio, don't break protocol (other than not having a call sign), and only transmit my position on maritime nets. My well-being is more important to me than government rules governing light waves. Unfortunately, I don't have a call sign to argue. From here on, I can only listen.

Thank gosh a person doesn't need a license to respond over the Internet. I haven't transmitted on the radio since I was ousted. Ned's letter makes me out to be some serial pirate



LATITUDE / RICHARD

**Zach is a little red-faced at being accused of having a cavalier attitude about laws.**

Ham operator. Being a passive listener to the 20-meter band since my ousting, I can tell you I am the least of the FCC's worries. Regardless, I don't transmit on any frequency anymore, and I don't condone it. *SailPanache.com* doesn't either. Sorry for offending anyone,

and know that the first thing I plan to do when I return stateside is get my Ham license.

As for the Galapagos, sarcastically talking about ignoring the port captain is different from actually avoiding port authority. If I meant to avoid port authority, I wouldn't have anchored in front of the Port Captain's office. As for Fatu Hiva, the port authority had no issue with me when I told them I made my landfall at Fatu Hiva.

I don't want to step on any toes, but I certainly don't want to be misrepresented. And as to Ned's point about my actions making it harder for future cruisers, while I may write sarcastically on my blog in an attempt at humor, I am always respectful when visiting other countries and dealing with authorities.

Zachary S.O. Lough  
*Panache*, 1976 Catalina 30  
[www.SailPanache.com](http://www.SailPanache.com)

*Readers — We're not going to get too worked up about this, as we understand both Ned's position as an experienced circumnavigator trying to keep order, and Zach's position as an eager but novice cruiser learning which rules must be followed and which are mere suggestions.*

*Given the fact that Zach had a radio with both Ham and SSB capability, it was unfortunate that he didn't realize he could have simply started his own SSB net, which doesn't require a license. All he needed to do was pick a name for the net, set a time and frequency, and convince others to participate. The farther cruisers get from the West Coast, the greater the number of SSB nets, and the smaller the number of Ham nets.*

### ↑↓ **RUNNING AGROUND IN THE DELTA? NO WAY!**

In our recent annual trip from Emery Cove to Rio Vista in the Delta, we had the misfortune of running aground about 20



# THE FINEST SAILS BEGIN WITH THE BEST SAILCLOTH

Our patented woven Vectran® sailcloth performs like the laminates with the durability of Dacron®, especially in roller furling applications. In fact, Vectran® is lighter, lower stretch, and retains its shape over a longer life than any sailcloth we've ever offered to cruising sailors. That's because Hood Vectran® is woven, not laminated to Mylar® film. And you can be sure that each sail we roll out is built by hand, with the same care and craftsmanship that has been the Hood hallmark for 50 years. To discuss your sailcloth needs – whether our state-of-the-art Vectran® or our soft, tight-weave Dacron® – give us a call today.

**FALL  
DISCOUNTS  
NOW IN EFFECT  
Save up to  
25%**

**HOOD Sails & Service**

**HOOD New Sails**

**HOOD Sail Repairs**

**HOOD Furling Conversions**

**HOOD Free Pickup & Delivery**



SAILMAKERS

## **Chesapeake**

*Jim Fair's Outbound 46  
with Hood Vectron  
Full Batten Mainsail,  
140% Genoa, and  
Solent Jib*

PHOTO COURTESY  
SWIFTSURE YACHTS  
[www.OutboundYachts.com](http://www.OutboundYachts.com)



**HOOD SAILMAKERS 465 Coloma Street, Sausalito, CA 94965**

**Call Robin Sodaro (800) 883-7245 (415) 332-4104 Fax (415) 332-0943 [hoodsails@aol.com](mailto:hoodsails@aol.com)**

**Visit our website for Special Online Discount Pricing... [www.hoodsailmakers.com](http://www.hoodsailmakers.com)**



## LETTERS

yards north of the deep water channel along the Port Chicago Reach, which is off the Concord Naval Weapons Station pier.

After several attempts to get our Catalina 34 free, we found that she was firmly stuck on the bottom. Several boats in the area witnessed our grounding, and stood off waiting to see if we needed help. *White Wolf*, a motor vessel, even tried to tow us off. But after multiple attempts and a complete soaking of their crew, they had to give up. We were finally towed to deep water by the professionals of Vessel Assist.

We would very much like to thank the crew of *White Wolf* and those mariners who offered assistance or stood by. It was very reassuring to know help was close. While no damage was done to our boat, and no lives were endangered, it was scary to be grounded in four feet of water — particularly with the tide going out, and the wind and chop building. Adding to our concern was the fact that one of the people on our boat was a 94-year-old making his maiden voyage to the Delta!

Gayle & Pete Vaughan  
Cover Girl, Catalina 34  
Benicia

*Gayle and Pete — A salute to all those who actively tried to help or at least stood by.*

Your incident reminds us of our all-time greatest grounding, which happened about 25 years ago. A doctor told us we'd die young if we didn't take more breaks from work, so we and a young novice sailing couple headed up the Delta on *Little O*, the first of three Olson 30s we've owned. We were doing a lot of 10s under a spinnaker in a fresh breeze as we passed the Martinez Bridge. When we got near the area where you ran aground with *Cover Girl*, we started telling the young couple how smart we were for being in the middle of the channel, because it was so very shallow on either side. Before we could even finish bragging, the Olson lurched a little, went into the mother of all slo-mo round-ups, and came to a halt heeled over at nearly 90 degrees. Fearing that the boat might somehow tip over even more and trap us, we dove into the water and swam away for as long as we could hold our breath. We were about 50 feet away when we surfaced — and were stunned to find we could stand in about three feet of water.

The young couple, clinging to the Olson and fearing that we'd be swept away, screamed frantically for us to swim back to the boat. They need not have bothered, for we were able to casually stroll back to the perpendicular boat in knee-deep water. In fact, we vividly remember sloshing over to the top of the masthead — which was at water level — and bending down to unclip the head of the spinnaker from the halyard.

It was obvious that no boat was going to be able to come to our rescue anytime soon, so out of desperation we got down on our knees by the bow and tried to lift, bounce, and ooch the Olson into deeper water. In one of the great surprises of our lives, thanks to the partial flotation, soft bottom, and strong wind at our backs, not only were we able to move the 3,000-lb Olson over to the channel, it wasn't even very hard. The only difficult part was avoiding getting left behind when the Olson reached deeper water, bolted upright, and took off like a bat out of hell.

When we later told our doctor about the incident, he told us we'd probably live the longest if we worked 24/7 and never went sailing again.

### ↑↓LIGHT UP!

I read with interest Michael Nagy's October letter expressing concern about the use of solar-powered LED lights — such as our RailLight — as anchor lights. We wholeheartedly agree that these lights are not designed for such use.

**15% OFF**  
SAIL KITS & FINISHED SAILS

EXPIRES DECEMBER 31, 2012.

Start your sailmaking adventure today with a custom Sailrite Sail Kit (or a finished sail if you're short on time). All sails are designed and plotted by our sailmaker, Jeff, in Indiana. Expect the best in materials, equipment, and craftsmanship. Plus all kits come with detailed step-by-step instructions, phone support, and your own cheer block.

GET A CUSTOM QUOTE

**800.348.2769**

[www.sailritesails.com](http://www.sailritesails.com)

# *If You're Reckless Out Here...*



## *We Can Haul Your Boat In Here.*

Bay Marine Boatworks offers estimates up front, plus a complete range of services at below-market prices. From bottom painting to complex fiberglass repair work, we can handle all of your sailboat and yacht maintenance needs. So if you have a mishap, bring your boat to us and we'll bring your boat some peace of mind. We offer:

- Over 35 years of experience in recreational yacht and boat repair
- Dry-docking capabilities for 28 shored vessels
- Trailer-able boat section
- 100-metric ton Travelift
- 600' of berth space in our deep water marina
- Can accommodate vessels with a max beam of 23' 4"
- Guaranteed absolute satisfaction to every customer



310 W. Cutting Blvd.  
Pt. Richmond, CA

**(510) 237-0140**

[www.baymarineboatworks.com](http://www.baymarineboatworks.com)

**BAY MARINE**  
  
**BOATWORKS Inc.**  
*The Sailor's Boatyard*

# CRUISERS!

## Head for Downwind Marine!

Official  
Sponsor  
2012  
BAJA  
HA-HA

### STILL MAKING PLANS TO CRUISE? READY TO PUSH OFF THE DOCK?

***Come One – Come All!***

### EVERYONE IS WELCOME to join us for our Special Events this Cruising Season!

For more details, check "Events" at  
[www.downwindmarine.com](http://www.downwindmarine.com)

### Cruising Seminars Continue!

Evenings - 6 PM - Doors open at 5:45 PM  
Back door at Downwind Marine  
2804 Cañon Street, San Diego  
\$3 per person unless otherwise noted

Thurs. 11/1 - Shea Weston (Offshore Outfitters)  
Introduction to Offshore Communication

Tues. 11/6 - Capt. Ann Kinner (Seabreeze Ltd.)  
Planning for Cruising – The Info Part

Thurs. 11/8 - Barry Kessler (Altra Regulators)  
Onboard (12-Volt) Power to the Cruiser!

Tues. 11/13 - Check our website for details

Thurs. 11/15 - Check our website for details

### *And Don't Miss Our*

### Annual Cruisers' Kick-Off BBQ with Vendor Fair and Potluck!

Saturday, November 3 • Noon-4 PM

- Special one-day discounts storewide – All Day!
- Meet our favorite product reps
- Cruisers come meet other cruisers
- We provide hamburgers, hotdogs and soda
- Cruisers bring a dish to share
- SPECIAL GIFTS for purchases over \$100

[www.downwindmarine.com](http://www.downwindmarine.com)

San Diego Marine Exchange



THE CRUISER'S CHANDLERY

2804 Cañon Street  
San Diego, CA 92106  
Phone: (619) 224-2733  
Toll-Free: (866) 289-0242  
Fax: (619) 224-7683  
info@downwindmarine.com

CRUISERS' NET, Ch. 68, from 8:30 am weekdays: WHX369

## LETTERS

Indeed, we constantly receive inquiries asking whether our RailLight Premium or RailLight Mini will work as an anchor light, and we are careful to tell potential customers that while they will certainly work as an emergency light, they are not bright enough — nor will they last through the night unless there is at least 12 hours of bright, direct sunshine on them each day — to substitute for a hard-wired anchor light.

That being said, our RailLights make an excellent emergency light. When my Venezia 42 cat was struck by lightning in Mexico some years ago, virtually all my electronics were fried. Were it not for my RailLights, a few flashlights, headlamps and flares, my boat would have been totally in the dark.

I have a RailLight Mini permanently rigged on my mast — and a couple in my cockpit — so that if my masthead anchor light ever goes out, at least there is some light on my boat. Especially in Mexico where unlit boats seem to be the norm.

Eric Sanford  
Hood River, OR  
[www.SolLight.com](http://www.SolLight.com)

*Eric — For years we had an incandescent anchor light atop Profligate's mast, and in addition to draining the batteries, that sucker was the dimmest bulb in the fleet. But we've had a masthead LED tricolor/anchor light/strobe hard-wired to our house batteries for the last five years, during which time we've had the brightest anchor light in just about every anchorage. We love it.*

### ↑↓ SHINE ON!

Michael Nagy's letter on the inadequacy of solar-powered LED lights for anchor lights really got me cranked. Some boats just don't run anchor lights, and others use these tiny solar-powered garden variety ones that are dead by 3 a.m.

I agree with Mike, and wanted to mention that the vessel he was referring to in La Cruz that stood out because of the blue bow and stern lights was/is our *Jacaranda*. We could pick out our boat in the anchorage before we even got off the bus coming home from Puerto Vallarta. In addition to the blue Bebi LED anchor lights, we also have an all-round white Bebi LED light just to be legal. Paranoid? You betcha! Our goal is to be seen and not hit!

In the age of inexpensive LEDs, for God's sake, toss those damn lawn lanterns overboard and get something that can be seen at 3 a.m. It always amazes us how many boats, even those with solar-powered lights, can't be seen. Try coming into La Cruz on a dark night with all the background lights, and you will be amazed how ineffective your solar powered anchor light really is. If someone runs into you because they can't see you, you will be held responsible.

We have been using Bebi anchor lights for a couple of years, and think they are fantastic. They switch on automatically and don't even move the digital volt meter. By the way, these are made by cruisers who employ local Fijians to make them. As they cost just \$39 and draw only .065 amp, it's well worth it to order one. Your cruising friends arriving after dark will be thankful at night, and your batteries will be happy in the morning. Thank you for letting me rant.

Chuck Houlihan  
*Jacaranda*, Allied 39  
Currently lying in La Paz

*Chuck — You're not ranting, as it really is often very difficult to see boats that are anchored out in Mexico. Like you, we think it's important to not only have a brilliant masthead*



Great  
Location

Deep Draft  
(510)  
236-1013



With a 12-ft deep entrance channel you can sail  
from Marina Bay  
whatever the tide!

**NOW  
BOOKING  
FOR 2013  
SEASON**

Available slips with  
15' or more depth:

- 40' long 15.6' wide 16' deep
- 42' long 15' wide 17' deep
- 44' long 16.6' wide 18' deep
- 56' long 20' wide 16' deep
- 61' long 18' wide 16' deep

End-ties to 100'+ and 16'+ deep

**On the Water:** 37° 54' 45" N 122° 21' 00" W

**Online:** [www.MarinaBayYachtHarbor.com](http://www.MarinaBayYachtHarbor.com)

# SCHOONMAKER POINT MARINA

• IN SAUSALITO •

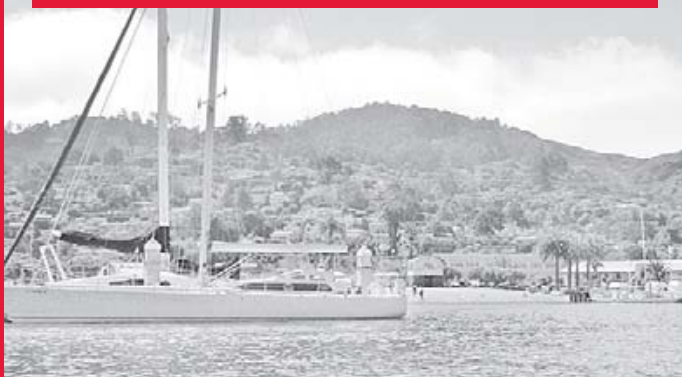

**160-Berth Marina in one of the  
most beautiful spots on the Bay**



Visitor berths • Guest moorage up to 220 ft.  
35-ft to 75-ft slips • Pumpouts • Marine services  
Dry storage available • Three-ton hoist  
Restaurant • Beach • Rowing • Kayaking

## Sausalito's Finest Marina

85 LIBERTY SHIP WAY, #205  
SAUSALITO, CA 94965

**415•331•5550**

**FAX 415•331•8523**

[www.schoonmakermarina.com](http://www.schoonmakermarina.com)

## LETTERS

*anchor light, but to also light up the deck level of one's boat. Bow and stern lights, such as on your boat, are a little hard because there are four corners on a cat, so we just make sure we leave at least two big CCFL panel lights on in the salon at night, too.*

### ↑↓ **JIM IS OUR 'WOOF' ROCK STAR HELMSMAN**

As you mentioned, San Francisco Bay racer and world cruiser Jim Jessie turned 80 last month — and is still racing.

I first met Jim Jessie in the mid '70s at Clear Lake when he was visiting his sister. I was sailing a Hobie 16 then, and his sister asked if I would give her brother a ride. When I was introduced to Jim, he had his pipe in his mouth — yes, even back then — and when he said he would be glad to take a ride on my boat, I asked if he could swim.

"That question does not inspire confidence in you," he replied.

In '78, he surveyed a Cal 2-29 I was buying — and still race today. I joined the Oakland Yacht Club and became a friend of Jim's. When he and Diana started their circumnavigation in '85, I was aboard going out the Gate and turning left. I made it all the way to Catalina, at which point I had to jump ship to return to work. They, as everyone knows, kept going and going and going.

Today, Jim is the helmsman and the 'Racing Instructor' aboard my boat, and we have a great time racing up and down the Estuary and in the Bay. The members of our crew refer to ourselves as 'WOOFs' — well-off old farts. Our average age is 73. When we lose our focus, as we sometimes do, Jim brings us back by saying, "Come on guys, let's do it just like we were racing!"

Dick Johnson  
Nice Turn, Cal 2-29  
Oakland YC

### ↑↓ **TWO OF THE MAIN CAUSES OF MISERY**

First rate October 15 *Lectronic* commentary on James Kwon, the high-ranking Port of Oakland official who, four years after the fact, was found to have spent \$4,500 of taxpayer money at a strip club in Houston one night. My question is what financial abuses have they not discovered yet?

Dave Barten  
Ikani, Aqua Lady 38  
Shelter Island

*Dave — For those who missed that Lectronic, the other person who 'Outraged Our Sensibility' was Francesco 'Chicken of the Sea' Schettino, the captain of the Costa Concordia cruise ship, which capsized nine months ago off the Italian island of Giglio with the loss of 32 lives. You might remember that Schettino had foolishly approved a 'cruise by' of the island so some of the crew could wave to family members ashore, was absent from the bridge and dining with a blonde at the time of the accident, was among the first to leave the ship, and despite repeated orders from the Italian Coast Guard to return to his ship to take charge — "Get back on board, for fuck's sake!" — he stayed on terra firma. As hard as it is to believe, Schettino is suing the cruise ship company for back pay, and to get his job back. If the irresponsible Schettino had had any self-respect for himself or his former position, he would have gone down with the ship and the other victims of his irresponsibility.*

*How did the former security guard get to be captain of one of the larger cruise ships in the world? Family connections, not merit. In other words, corruption, which along with the lawyer-*

ECO-FRIENDLY

# HULL PAINT

2012 REVISED OFFER

60% OR 75%  
OFF HULL PAINTING



The Port of San Diego is proud to present our newly revised grant program which subsidizes qualified boat owners in the **Shelter Island Yacht Basin** who elect to use eco-friendly hull paints.

To learn more, go to:

**[sandiegobaycopperreduction.org](http://sandiegobaycopperreduction.org)**

call 619-686-6283 or email  
[hullpainttransition@portofsandiego.org](mailto:hullpainttransition@portofsandiego.org)





- NEW
- USED
- REFINANCE



# Boat Loans Made Easy®



Let our 30 years of experience go to work for you!

Call  
**866-377-3948**  
**www.essexcredit.com**

EQUAL CREDIT OPPORTUNITY LENDER

Loan Amounts from \$25,000  
Instant Loan Approvals\* • 90 Days to First Payment\*

\*Subject to Loan Program Guidelines and Credit Approval  
Reference Code = MAR931

## LETTERS

*driven contention that nobody is ever responsible for the terrible consequences of their irresponsible actions, are two of the main causes of misery in this world. At least to our thinking.*

### ↑↓ **SETTING THE WINDJAMMER RECORD STRAIGHT**

I just read *Latitude's* report on the Windjammer's Race to Santa Cruz, and need to correct you. The overall winner was actually Howard Turner's J/109 *Symmetry*, which not only won Class 1, but had the fastest time in classes 1 and 2, beating *Kokopelli 2*, the other class winner, by about 12 minutes.

Jay Crum  
Piñata, Olson 30  
Santa Cruz

*Jay — Our apologies and congratulations to Howard Turner and the crew of Symmetry.*

### ↑↓ **A DOCK OF THE BAY**

With public interest in the America's Cup on the increase, boatowners might be interested to note that La Mar Cebicheria Peruana restaurant, located on Pier 1.5 in the heart of the San Francisco waterfront, has its own public dock where vessels up to 40-ft can tie up for up to three hours at no charge. Of course, boatowners don't even have to care about

the America's Cup to take advantage of the dock.

Tom Walton  
San Francisco

*Tom — Thanks for the reminder, as San Francisco sailors are always looking for new places to visit with their boats.*



LATITUDE / LADONNA

*Pier 1.5 has been open to boaters — for free — since 2007.*

### ↑↓ **DON'T FORGET THE TUBES AND THE SLIME**

Thanks for the well-written piece about the pleasures of bringing smaller bikes on boats. As an avid rider and ex-racer, I would advise bringing at least three extra small tubes and tires. Most cruisers weigh more than they did when they were kids, and will tend to wear out two back tires for every front tire. And quickly, too. Replacement tubes and tires are hard to find here in Mexico and many other countries. In addition, cruiser/bikers should also buy a couple bottles of green Slime, the stuff you squirt into the inner tube to stop those nagging flats.

Bikes and cruising boats — a good combination.

Bob Walker  
Cactus, Hunter Cherubini 37  
Wofford Heights / La Paz

### ↑↓ **CRUISERS SHOULD STOP AT ENSENADA**

Thanks for the recent great coverage of Ensenada. We were down there in August from Long Beach, and were once again impressed with the facilities and the friendly people. We were on a short stay, so the Cruiseport Marina staff did a great job of expediting our paperwork, giving us the maximum time to enjoy the town and the sights. Many more California cruisers should make a cruise to Ensenada. After all, it really is Mexico, and if you do the Bash back at night, it's easy.

Bob Schilling  
Tuckernuck, Cherubini 44  
Long Beach



# Almar Marinas

Everywhere you'd like to be



Est. 1973



Martinez Marina 925.313.0942

Join one Almar Marina and enjoy reciprocal privileges at any of Almar's 16 locations from San Francisco to San Diego and out to Hawaii. Each marina provides programs and events that are included in your slip fees:

- \*Boat Handling
- \*Navigation Courses
- \*Electrical Courses
- \*Anchor Outs
- \*Seminars on Local Destinations

[almar.com](http://almar.com)





**SOUTH  
BEACH**  
H·A·R·B·O·R

**South Beach Harbor is a great way to experience San Francisco. Boats of all sizes are welcome in our protected deepwater harbor. Bring your boat to South Beach and enjoy all the attractions of the city.**



- Two guest docks for boats up to 125'**
- 20 guest berths up to 50'**
- Casual and fine dining nearby**
- Adjacent to AT&T Park**
- Easy access to transportation**
- 24 hour security**
- Free pump-out stations**



**For Reservations:**  
415.495.4911 (x1111)  
fax: 415.512.1351

[www.southbeachharbor.com](http://www.southbeachharbor.com)

## LETTERS

*Bob — We did two trips to Ensenada this summer, and really enjoyed ourselves on both occasions. Yes, at first glance the downtown area looks as though it could use a little spiffing up, but we quickly forgot all about it as we were swept up by the friendliness of the people of Mexico. Because Ensenada is so close to California, sometimes we think it's not really Mexico. But it is.*

*From now on, Ensenada is going to be our last stop when doing a Baja Bash at the end of each cruising season — and not just because fuel is so much less expensive than in the States. We're also putting early October's Little Ensenada Race, followed a day later by the 16-mile Todos Santos Race, on our annual calendar. They were a blast. We're going to try to get more multihulls, too, because being the only other boat on the starting line with the old Waterworld trimaran was a little lonely.*

*The other thing that surprised us about Ensenada is how many veteran cruisers have elected to base there — instead of a U.S. harbor — because they like it more.*



LATITUDE / RICHARD

**Jan and Ramona Miller of 'Jatimo' have lived aboard at Marina Coral for three years.**

*Ensenada Mayor Enrique Pelayo told us that he understands how important it is for American boatowners to be able to clear into and out of Ensenada quickly and at minimum expense. Despite the fact that Immigration and visas are federal matters, he and local legislators are working to get the federal government to make Ensenada a special zone — sort of like Tijuana and other border towns — where visitors coming for less than 72 hours don't have to do paperwork or pay for a visa.*

### ⇕ **WHICH NAVIGATION APP IS THE BEST?**

Having recently woken up in the morning on the Napa River to pea soup fog, a falling tide and a need to get back down river that day, I am now duly impressed with navigation apps for Apple products. Without our being able to see very far, one crewmember simply and quickly downloaded a navigation app, and it worked flawlessly. However, there seems to be a number of navigation apps, and I'm wondering if *Latitude* or any *Latitude* readers have a preference.

P.S. I absolutely love *Latitude*, so please don't retire.

Art Hartinger  
Pied-a-Mer, Beneteau First 310  
South Beach Harbor

*Art — Thank you for the kind words.*

*The only marine navigation app we've used extensively is Navionics, and we've been very impressed with it, no matter if we were navigating in California, Mexico, or the Caribbean. Because the Navionics app has worked so well, we really haven't given iNavX a try, and that may have been our loss, for apparently the iNavX has a lot of features that the Navionics doesn't.*

*For instance, iNavX has all the free NOAA raster marine charts, with detailed coverage of the U.S. West Coast, Gulf Coast, East Coast, Great Lakes, Alaska, Hawaii, and US Virgin Islands. It also can make your iPad or similar Apple product*



Paradise Village  
MARINA  
BANDERAS BAY

*Voted best Marina in Mexico*

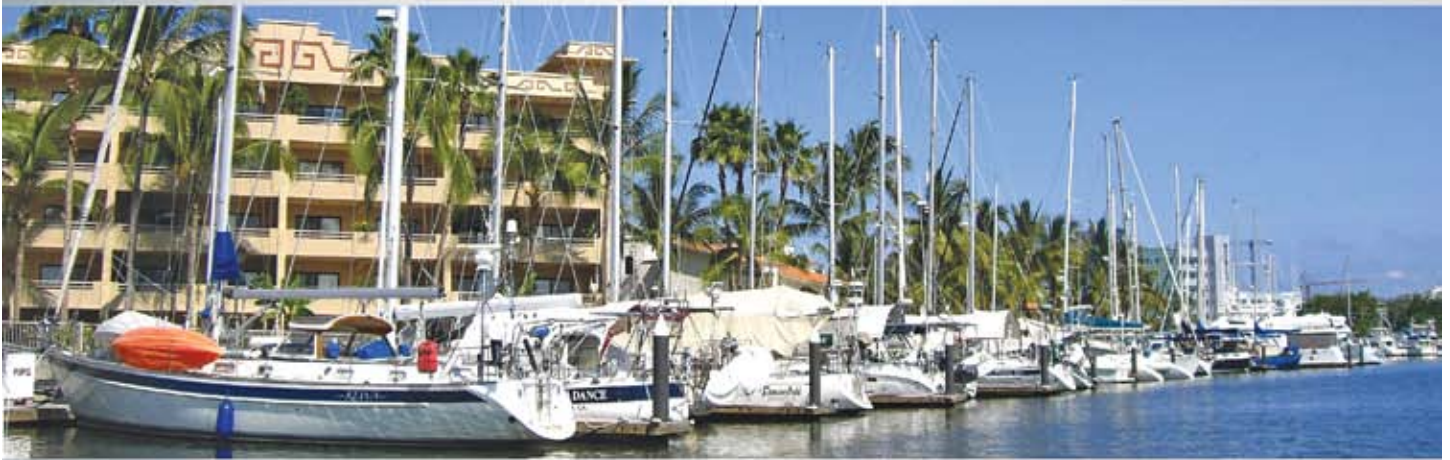

## *Services:*

- Electrical service, 110/30 amps · 220/50 amps, 3 phase 100 amps and 3 phase 480v · Crystal Clear Potable Water ·
- Cable TV · Garbage Collection · Pump - out Station · Fire Fighting Boat Protection · 24 Hrs. Security · Computerized gate access ·

## *Additional Services:*

- Vallarta Yacht Club · Special area for marina guests · Restrooms · Lockers · Showers · Pool and jacuzzi
- Free access to all the facilities of our 5 star hotel · White sand beach · Dive tank refilled · Propane refill · Launch ramp

CONTACT US: [marina@paradisevillagegroup.com](mailto:marina@paradisevillagegroup.com)

Phone & fax from U.S. 011-52-322-22-66728 · GPS Coordinates: 105° 17.9 W 20° 41.2 N

Yacht owners trust

## Pacific Crest Canvas

for the best in design, service and quality.



We strive to make our products the  
**Highest Quality at the Best Prices**

Specializing in:

### Baja Awnings

Lightweight and waterproof  
Durable and easy to launch  
Multiple side screen configurations

### Coastal Dodgers

Affordable designs  
High quality materials  
Superior workmanship

### Cruiser's Awnings

Easy setup off your dodger  
Flies with no bulky frame  
Includes shade screens

### Offshore Dodgers

Welded aft handrail  
Bolt-on side handrails  
Lexan windshields



[www.pacificcrestcanvas.com](http://www.pacificcrestcanvas.com)

Located in Grand Marina  
2021 Alaska Packer Pl., Ste. 13  
Alameda, CA 94501

Open Mon.-Fri. 8-4  
Sat. by appointment  
510-521-1938

## LETTERS

function as a repeater for popular marine navigation software that supports NMEA data over TCP/IP. We're talking about GPS, AIS receivers and transponders, and depth, speed, wind, engine, and battery instruments. According to the press release,



ART HARTINGER

**Navionics and iNavX are two of the more popular marine navigation apps available for the iPad.**

iNavX gives you "the power of a color chart-plotter for a fraction of the cost." As far as we're concerned, the anchor alarm is worth the entire \$49 price.

So our highly technical and definitive product review is as follows: Navionics is a terrific marine navigation app, but for all we know, the iNavX app might even be better."

To comment — on the products, not our review — email [richard@latitude38.com](mailto:richard@latitude38.com).

### NEW FOR OLD IN THE THIRD WORLD

It was good to read your timely note about rebuilding diesels, as we ourselves were faced with a diesel problem here in Turkey. But after a week of twisting on a mooring in a little Turkish fishing harbor, we have decided that we will repower with a new Yanmar rather than rebuild.

Our *Angel Louise* is a 25-year-old Catalac 41 catamaran and was repowered 20 years ago by her previous owner. He did it partly to get more power, so he installed twin Yanmar 3JH2Es. Those two 37-hp diesels mean we usually can motor faster than we can sail.

We bought *Angel Louise* in '07 as our 'retirement home' after auctioning off our real home in Des Moines, Iowa, and all our stuff in it. We've since been across the Atlantic with her, spent a winter in England, and most recently did a very rare west-to-east crossing of the European continent. She's been a grand retirement home, and provided us with a way to see a lot of the world and life as well.

Anyway, we lost the right engine two months ago when cruising down the Danube River just short of Belgrade, Serbia. From there on — including through Romania and the Black Sea to Istanbul, where we resteped the mast — we had the use of only one engine.

Maneuvering *Angel Louise* with just one engine was hairy. In part because the remaining working engine was offset from the centerline of the boat, but also because there was a strong following current in the rivers. Trying to stop or maneuver *Angel Louise* with one engine was sort of like trying to stop a car with one brake locked on winter ice in Iowa. Given the sometimes narrow channels, and the huge sandbanks in them, we easily could have been stranded for the entire winter.

Nonetheless, our trip from the Netherlands and over the continental divide of Europe — elevation 1,340 feet above sea level — was well worth it. Plus, we had a nice 48-hour sail down to and through the Bosphorus into and through Istanbul. For those not familiar with the area, the 31-mile long Bosphorus, also known as the Istanbul Strait, forms part of the boundary between Europe and Asia. Connecting the Med to the Sea of Marmara — and from there the Black Sea — it's the narrowest strait in the world that is used for international navigation.

Anyway, we stumbled upon this local fishing harbor at Istanbul where the locals took us under their wing, despite

# Lighted Yacht Parade

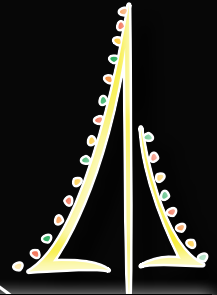

36th Annual

**SATURDAY, DEC. 1, 2012**

Oakland/Alameda Estuary

Starting at 5:30pm

**[www.LightedYachtParade.com](http://www.LightedYachtParade.com)**

for more info and to register.

Entry deadline: Nov. 27, 2012.

Entry fee: \$30

(includes a skipper's goodie bag)

Hosted by Encinal Yacht Club and Oakland Yacht Club.

<small>Platinum Sponsor</small>  <b>CU HomeLand</b> Mortgage Company Pleasanton • 800-795-1333
<small>Platinum Sponsor</small>  <b>Phillips 66</b>
<small>Gold Sponsor</small> <b>Studio of Margaret W. Fago</b> Painter • 510-522-1309
<small>Gold Sponsor</small>  <b>SailTime</b> San Francisco • 415-869-2861
<small>Silver Sponsor</small> <b>Marina Village Yacht Harbor</b> Alameda • 510-521-0905
<small>Bronze Sponsor</small> <b>Southern Wine &amp; Spirits</b> San Francisco • 925-948-5398
<small>Bronze Sponsor</small> <b>Rosenblum Cellars Winery</b> Alameda • 510-865-7007
<small>Bronze Sponsor</small> <b>Bladium Sports &amp; Fitness Club</b> Alameda • 510-814-4999
<small>Bronze Sponsor</small> <b>KKMI</b> Yard • Sales • Store Sausalito • 415-332-5564

## Two Unique Boat Products From Scandia Marine

# MARINE LADDERS

### DEPLOYABLE FROM THE WATER



#### THE LINKS MAKE IT RIGID

- Electropolished 316 Stainless
- Easily Extended and Collapsed
- Rigid - Will Not Kick Under



# UP-N-OUT

ULTIMATE MARINE LADDERS By Scandia Marine Products

# 30% PRE-SEASON DISCOUNT

Good On Any Size Wheel Up to 63" Through 2/28/13



## ColorWheelz

VINYL DIPMOLD WHEEL COVERS



(651) 464-5058

[www.scandiamarineproducts.com](http://www.scandiamarineproducts.com)

## LETTERS

the fact that none of them speaks any English. They gave us a free mooring right in the middle of their harbor, and insisted that we pay nothing for it. Everyone greets us with smiles and a friendly "Merhabba," which means 'hello'. They could not have made us strangers feel any more welcome.

We managed to find a true 'salt of the earth' local mechanic, who, along with his two sons, lifted the 400-lb engine out of



COURTESY ANGEL LOUISE

**Repowering your boat in the Third World isn't easy but it's not that hard either.**

*Angel Louise's* right engine well. After driving it to the mechanic's shop 20 miles away, they found that the crankshaft journal — the part the #1 piston connects to and rotates around — had worn away to the point that the piston was flopping up and down and not working, making the engine shake horribly.

With the help of folks who follow our travels by email, we did a search for a new crankshaft. After searching in Japan, the United States and Europe, we found that the very last crankshaft in the Yanmar system had been sold while we were searching for it, and Yanmar had no plans for making more. We had been prepared to fly to wherever and bring a crankshaft back in a suitcase, but we heard that there is a lot of red tape involved in bringing parts to boats 'in transit'.

Even if we could have found the crankshaft, the cost of rebuilding our engine was going to be close to half the cost of a new one. And if we rebuilt the engine, we would be rebuilding a 20-year-old engine that already had seen 7,500 hours of service. I figured that was akin to rebuilding a car engine with 250,000 miles. Not a pleasant thought to ponder since we would be crossing the Atlantic a year from now.

I'm writing the day after we paid half down for a new Yanmar 3JH5e. It is to be delivered out of a bonded warehouse



COURTESY ANGEL LOUISE

**'Angel Louise' in Avcilar, Turkey.**

next week to the Yanmar distributor. We hope our friends in the engine shop will be able to put it into *Angel Louise* on Wednesday, and the electrician can wire up our old panel and instruments to certify it for warranty purposes. An additional bonus of buying a new engine is that we'll be able to carry the old engine's 'top shelf', and all her other critical parts, for spares for the remaining 3JH2E to use to keep her going.

Readers would have been amazed to see these Turks lift the old engine out of the well and slide it to the stern, then lift it onto a helping fisherman's boat. It was a very scary job, with two guys balancing a huge and heavy engine, and putting it on shore before loading it into their truck. I fear my heart will race seeing the same trip in reverse bringing the new engine to the boat at her mooring. But that's how they do things in Turkey — and the Third World.

Our cruising adventure continues into year six! We will spend the winter at Marmaris on the 'Turkish Riviera'. Next year we'll complete our circle of Europe by sailing west across

# 10 reasons why boaters choose BERKELEY MARINA

- 1 Direct Access to the Bay**  
The best boating experience as soon as you leave the beautiful harbor!
- 2 Free Mobile Pumpout Service**  
Berkeley Marina has teamed with BayGreen to offer Free once-a-month mobile pumpout of your holding tank (through 2012).
- 3 Free WiFi**  
The Marina now offers free WiFi access to the internet.
- 4 Sailing Schools & Clubs**  
OCSC Sailing, Cal Sailing Club, Cal Adventures – More chances for learning & community!
- 5 Berkeley Yacht Club**  
One of the friendliest clubs on the bay – Get involved: racing, cruising, social activities... **Now – membership fee waived!**
- 6 Berkeley Marine Center**  
One of the Bay Area's most popular, full-service boat yards!
- 7 Liveaboard Permits Available**  
Make Berkeley Marina your home!
- 8 Fuel Dock & Pumpout Stations**  
Open 7 days a week.
- 9 Full Amenities**  
Berther-only bathrooms, laundry facilities, gated docks...
- 10 Much More!**  
Bait shop & deli, launch ramp, hoists, fish cleaning stations, paved parking, free washdowns for trailered boats...

Contact the Marina Office for details



*It's a boating community!*

**Berkeley Marina Office**  
**201 University Ave. • 510-981-6740**

Visit our website at: [www.ci.berkeley.ca.us/marina](http://www.ci.berkeley.ca.us/marina)



**CITY OF BERKELEY**  
PARKS RECREATION AND WATERFRONT

# Uncle Sam wants to make the down payment on your new Beneteau



## Club Nautique wants to make the payments!



No. We're not crazy. We've been doing this for over 30 years, but this program ends this year, so call us today for details.

**Call Today!**

Don Durant  
510-865-4700 x 305

**Club  
Nautique**

You're at the helm!  
[www.clubnautique.net](http://www.clubnautique.net)

## LETTERS

the Med, then follow in Columbus' wake across the Atlantic.

Ed & Sue Kelly  
Angel Louise, Catalac 41 catamaran  
Istanbul, Turkey

*Readers — It's hard to say how many hours is a lot on a diesel, but 7,500 doesn't sound like that much. We say that because both of 'ti Profligate's diesels have close to 9,000 hours and have — touch wood — been running great. The mechanics at the charter base tell us that it's not uncommon for diesels in frequently used charter boats to run for 14,000 hours. But things like not changing the oil on schedule, lugging the engine, and running dirty fuel are just three of the many things that can dramatically shorten the lifespan of a diesel.*

### ↑↓ **BE PREPARED TO BLEED**

I rebuilt my Perkins 4-108 diesel in the late '80s after it spun a rod bearing while motoring up the coast. My prior experience was having helped rebuild a Model A Ford engine as a teen, building a Ford Cortina (British) 4-banger for SCCA production-class car racing in my 20s, and having overhauled a couple of dunked outboards. So I had some idea what I was doing, and I had the help of a San Rafael machine shop.

It also helped that I was rebuilding a durable — considering that it was British — engine. When I tore my Perkins down at a friend's shop, he was tearing down the GM 6-71 diesel that ultimately ended up in *Alert*, Harold Sommer's tug. I noticed that I took seven parts off my Perkins for every one he took off his Detroit Diesel.

Getting the engine out of the boat, and later putting it back in, was fun. Seriously. I looked at it as a heavy puzzle. It took some thought, a couple of timbers, a chain hoist, a come-along, padding, and the ability to hold one's breath. But no teak got scratched, and only about an ounce of blood was spilled.

I got lucky when it came to parts. That model Perkins was popular in tractor-trailer refrigeration units, and I found a San Leandro refrigeration outfit that was wisely switching all its reefer units over to Yanmar diesels. Thus they had no further use for their stash of Perkins parts. So I managed to buy a brand-new crank, rods, pistons, pins, valves and springs, an injection pump, and such — all for a dime on the dollar.

By working slowly and carefully, and never when tired, and with several smart mechanic friends to check procedures with, I got the engine back together and into the boat. It was a success, and I was amazed. The engine ran sweetly for years — until the sensitive, ethereal sort who bought my boat promptly ran it without water and fried the thing.

I would not advise the mechanical clubfoot to take on such a project, but anybody savvy enough to go world cruising successfully with limited funds should be able to rebuild a small diesel. After all, they get overhauled under astoundingly crude conditions in the Third World all the time. But it does take some common sense, and a willingness to get dirty and to bleed some.

Brooks Townes  
Port Townsend, WA

### ↑↓ **SHINY NEW PISTONS ARE MY KIND OF JEWELRY!**

I offer a woman's point of view on diesel rebuilds. I've had three boat diesels rebuilt to varying degrees, and found each one to be a learning experience.

The first was an engine rebuild and repair of a broken crankshaft on my Columbia 43's Perkins 4-108. I did this on the dock at Marina de La Paz in '94 under the tutelage of a



35-50' slips available

# Own a Dock on San Francisco Bay

## Perfect Location - Great Investment!

**EMERY COVE**  
YACHT HARBOR

### Come secure a front row seat for the cup races in 2013

- **BUY A SLIP** - Save money and earn equity! Enjoy tax savings. Listings start at \$35,000. Emery Cove Yacht Harbor is the only marina on the Bay with FEE SIMPLE (not a grounds lease) dockminium ownership.
- **RENT A SLIP** - 35-60' slips, rates from \$9.25 to \$10.25 per foot.
- **AMENITIES** - Free Wireless Internet and Marina Guard® ground fault monitoring.

**ON PREMISES**

- ChartersSF • Emeryville Yacht Club • Mathiesen Marine
- Michael Wiest Yacht Sales • Sailtime
- Seaward Coastal Ventures



**CALL FOR A MARKETING PACKAGE | 510-428-0505**

3300 Powell Street, Emeryville, CA 94608 | [www.emerycove.com](http://www.emerycove.com) | Email: [info@emerycove.com](mailto:info@emerycove.com)

## Michael Wiest Yacht Sales

**QUALITY SAILING YACHTS**



Scan with your smart phone for a list of our yachts.

Three convenient San Francisco Bay Locations!

3300 Powell St, Emeryville | (510) 601-5010

25 Third St, San Rafael | (415) 453-4770

400 Sierra Pt Pkwy, Brisbane | (650) 589-8990

[www.mwiest.com](http://www.mwiest.com)



**36' HUNTER SLOOP, 2006**  
Bristol condition!  
**\$144,000**



**47' WAUQUIEZ, 1984**  
**\$229,000**



**44' HUNTER DECK SALON, 2005**  
140 hours. 'Like new' condition.  
**\$189,000**



**34' ALOHA, 1982**  
**\$44,900**



**35' FUJI KETCH, 1975**  
John G. Alden design.  
**\$44,000**



**40' BRISTOL YAWL, 1981**  
Very well maintained.  
**\$64,000**



**44' MOODY, 1997**  
New listing.  
**\$199,000**



**32' WESTSAIL**  
Factory built, in great shape!  
**\$39,900**



**40' CALIBER, 1997**  
Motivated.  
**\$189,000**



**37' PACIFIC SEACRAFT, 2000**  
**\$164,000**

- 41' CORONADO TALL RIG, 1972.....\$34,900
- 41' PEARSON BOUNTY, 1961.....\$33,500
- 35' SANTANA, 1979.....\$19,900
- 34' SAN JUAN SLOOP, 1984.....\$19,900
- 34' ISLANDER SLOOP, 1969.....\$26,000
- 29' FARALLON SLOOP, 1976.....\$18,995
- 24' CORSAIR SPRINT, 2008.....\$44,900



**West Marine®  
Rigging Service**

# Sail Handling Made Easy

## Ask us about:

- Custom Lazy Jacks
- Top-down Spinnaker Furling
- Mainsail Reefing Systems
- Powered Winches
- 2:1 Main Halyard
- Soft Shackles

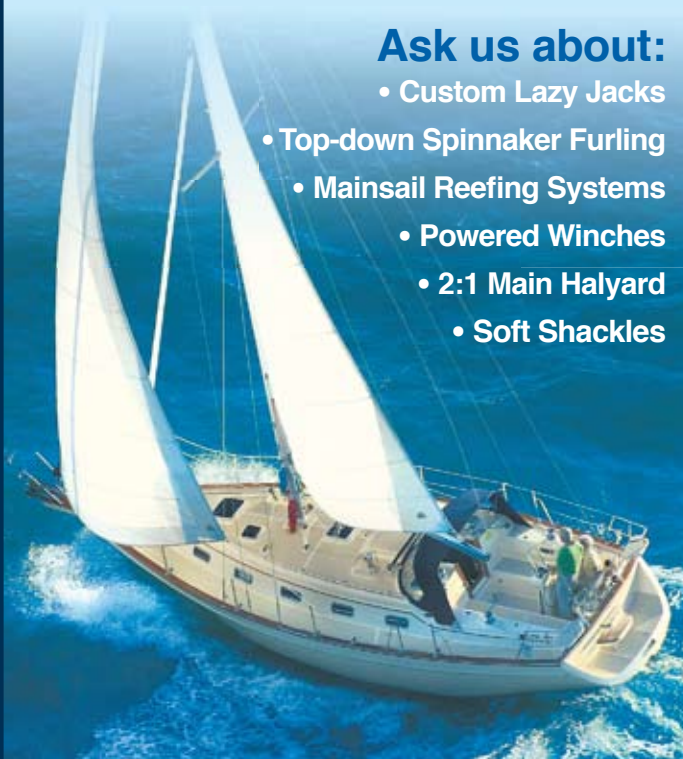

**SCHAEFER  
MARINE**

**FSE ROBLINE**  
WORLD CLASS YACHTING ROPES

**RONSTAN**

**POWERLITE**  
ROD RIGGING

**Johnson**  
Marine Hardware

**NEW ENGLAND ROPES**  
FOURTIMES IN MOTION

**samsun**

**facnor**  
FURLING SYSTEMS

**Hayn Marine**

**holmatro**  
marine equipment

**FORESPAR**

**SmartRigging**  
The Intelligent Choice

**HARKEN**

Contact us for all of your Rigging Needs!

**888-447-RIGG**

or visit our Onsite Rigging Locations in:

**Alameda, CA** 730 Buena Vista Ave. (510) 521-4865  
**San Diego, CA** 1250 Rosecrans St. (619) 255-8844  
**Seattle, WA** 1275 Westlake Ave. N (206) 926-0361

[www.westmarine.com/rigging](http://www.westmarine.com/rigging)

## LETTERS

fellow cruiser who was also a mechanic. Every evening he'd come by for his sundowner and to assign me tasks for the next day.

In '95, an oil line split on that same engine, causing it to seize. This time I did the rebuild on the dock in Portland under the daily guidance of a friend who owned a Portland boatyard.

On the way to La Paz after the Ha-Ha in '09, the diesel on my Gulfstar 50 *Talion* gave it up. Since it was a much bigger engine than I'd had on the Columbia 43, and because I'm older and wiser, I had Colin, a *gringo* friend in La Paz, do the rebuild. Lucky for me, Colin let me do what I could — the wiring, plumbing, painting and cleaning — to keep the cost down.



PATSY VERHOEVEN

**Rebuilding a diesel means lots of organization and lots of parts.**

All of my diesel rebuilds have been overwhelming and filthy tasks that ran over budget. On the plus side, I learned so much about my boat and engines from my three mentors that I'm no longer as intimidated when things go wrong.

Patsy Verhoeven  
*Talion*, Gulfstar 50  
La Paz, Baja California Sur

### ↑↓ NOT WITHOUT ACCESS TO A PROPER MACHINE SHOP

For the last 12 years I have been tending to the diesel engines aboard our three charter cats here in Belize. We have a Lagoon 47, a Lagoon 500, and a Voyage 500 that our son manages. All have twin Yanmar diesels. So I probably have a lot more time on diesels than do most cruisers.

Even though I consider myself to be a reasonably competent mechanic, I would never, ever try to rebuild one on my own without access to a proper machine shop. In addition, you should remove the engine from the boat and have the proper, clean space to work on it. Otherwise, you are probably wasting your time — not to mention the considerable cost of the parts. Once you start a rebuild, you will probably want to have the head planed, the valves ground or replaced, and so forth.

By the way, things are great here in Belize.

Cliff Wilson  
Aubisque, Lagoon 47  
Belize

*Readers — Cliff was a very active San Francisco sailor for many years. He did the TransPac twice, once with Troublemaker, his IOR One-Ton in '81, and once aboard the Lee 67 Merlin as part of a charter group in '83. He later sailed on the Leigh Brite's Express 37 Ringmaster and was part of a championship effort for several years on the J/40 China Cloud.*

### ↑↓ DETERMINING A GOOD REBUILD CANDIDATE

Should an average do-it-yourselfer try to rebuild a diesel engine? What a great question!

The important first step is to determine what's wrong with the engine, assuming it's something beyond the normal high hours. For example, if the engine had been overheated, there could be internal cracks that would be hard to find — unless

PHOTO: DAVE TOWLE



Discover  
Brisbane  
Marina



From Hwy 101, take the Sierra Point Pkwy exit and follow the signs to the marina.

**GREAT LOCATION!** Just minutes to Central Bay sailing.  
**GREAT STAFF!**  
**GREAT RATES!** Starting at \$6.02/foot!  
**MARINA GREEN** with picnic/BBQ areas, Bay Trail Access and FREE Wi-Fi.  
**HOME OF THE SIERRA POINT YACHT CLUB**



400 Sierra Point Parkway  
Brisbane, CA 94005  
[www.ci.brisbane.ca.us](http://www.ci.brisbane.ca.us)  
**(650) 583-6975**  
harbormaster@ci.brisbane.ca.us

## KISSINGER CANVAS

Marine Canvas & Interiors  
STEVEN KISSINGER  
**(925) 825-6734**  
Covering the Entire Bay Area



- Biminis
- Boat Covers
- Cushions
- Sail Covers
- Headliners
- Awnings

## DODGERS

Side handrails and window covers included.

### OPTIONS

Aft handrail, dodger cover, sailing bimini.  
*Free Estimates and Delivery*



*53 years of worldwide service ~ Shipping to every ocean*

- Expert staff
- Used hardware
- Special Orders
- Lowest Prices for new items
- Service loft, modifications, cleaning and repairs

**SAILS ♦ SHIP STORE ♦ CONSIGNMENT**  
*Brand New Coastal Cruising Sails For All Boats – SUPER LOW PRICES*

**(410) 263-4880**  
**[www.BaconSails.com](http://www.BaconSails.com)**

116 Legion Ave., Annapolis, MD 21401

# WHALE POINT MARINE & HARDWARE CO.

**A FAMILY OWNED & OPERATED BUSINESS FOR THREE GENERATIONS**  
**ACE Hardware**  
 MARINE PARTS & ACCESSORIES, PLUS A COMPLETE HARDWARE STORE

Go to [WhalePointMarine.com](http://WhalePointMarine.com) for additional discounts!

## WEEMS & PLATH Chart Weights

Double duty chart weights, use compass and/or clock to hold charts flat. Comes in brushed nickel or bronze.



Now \$29<sup>99</sup> each

## WELCOME Aboard Mat

Now \$29<sup>99</sup>



## ORION Alert/Locate Deluxe Kit

Comes complete with flare gun, flares, whistle, flag, info CD... all in a waterproof case.



List \$149.99  
 Now \$119<sup>99</sup>

## LELAND Strobe Light

Now \$19<sup>99</sup>

Small and compact strobe light, fits in ones pocket, with 3-mile visibility, waterproof and last for 30 hours. D Cell Battery not included.



## STEARNS Cold Weather Gloves



Now \$19<sup>95</sup>

## GILL Rigging Knife

Comes with case



Now \$21<sup>99</sup>

## MUSTANG Float Coats



MJ6214TI • Bomber Style • \$239<sup>99</sup>  
 MC1524 • Long Jacket • \$299<sup>99</sup>

## MUSTANG Inflatable Vest

No inadvertent inflation under extreme conditions



MD3183 • NOW \$259<sup>99</sup>  
 MD3184 • With Harness • NOW \$279<sup>99</sup>

205 Cutting Blvd, Corner of 2nd, Richmond  
 510-233-1988 • FAX 233-1989  
 Mon-Sat: 8:30am - 5pm • Sun: 10am - 4pm • [whalepoint@acehardware.com](mailto:whalepoint@acehardware.com)  
 Go to [WhalePointMarine.com](http://WhalePointMarine.com) for additional discounts!

## LETTERS

all components were magna-fluxed. With severe overheating and an engine that would not run correctly, attempting a rebuild would be a gamble.

But if we're talking about a dependable old diesel with a trillion hours that still runs, was never overheated, but blows oil through, that would be a good candidate for a rebuild. Of course, the do-it-yourselfer would still need good tools and some experienced machine shop or mechanic to walk him/her through it.

Dave Biron  
 Big Break Marina, Oakley

### ↑↓DON'T BOTHER TO JUST SAVE MONEY

I would say 'no', it's not appropriate for the average boatowner to try to rebuild a boat's diesel engine. First, you need special tools that you'd need only once. Second, you need to spend a lot of time becoming knowledgeable before you begin. And three, just the smallest mistake can ruin the engine.

That said, I think the kind of sailors who built their own boat would be right at home rebuilding their diesel engine. So for some boaters — the kind who derive as much joy from the building and maintenance process as from sailing — it makes complete sense. But forget it if you're just trying to save a few bucks.

Greg Retkowski  
 San Jose

*Readers — Greg cruised his Morgan Out-Island 41 Scirocco from California to Florida, then built his own airplane, and is now, with his wife Cherie, looking to buy either an F-27 or an F-31 trimaran.*

*We got a tremendous amount of response to our 'should a do-it-yourselfer try to rebuild a diesel' question, and will have more responses next month.*

### ↑↓ANOTHER GREAT LATITUDE EVENT

I was crew on Paul Martson's Contour 34 trimaran for the first ever SoCal Ta-Ta in September, and we had a great time! The sailing was absolutely perfect — and we didn't have to bring the boat all the way back from Mexico as we do after a Ha-Ha. Congrats to the Grand Poobah and the Ta-Ta staff for pulling off such a wonderful and well-organized event.

Jared Brockway  
 Orange, Contour 34  
 Ventura

*Jared — Thanks for the kind words, but no matter if it's Latitude's Baja Ha-Ha, SoCal Ta-Ta, or Delta Doo Dah, what makes an event are the participants. We love doing these events — well, Christine Weaver and LaDonna Bubak run the Doo Dah — because the participants have been so fun, so interesting and so responsible.*

### ↑↓IT'S ALL ABOUT THE FOOD

In the article about the Ta-Ta, you wrote that you were surprised that none of the six people on my little Cal 27 jumped ship. The explanation can be found on Carmela's menu for the week, which included roast lamb, linguine, heroes, taquitos, burgers, bacon and eggs, and tons of salad. By the way, thanks for all your organizing work, as it made the trip a huge success for our crew. We can't wait for next year's Ta-Ta II.

Jean Mondeau  
 Carmela, Cal 2-27  
 Madera

# Yachtfinders/Windseakers

in the heart of  
San Diego's boating community

2330 Shelter Island Dr. # 207, San Diego, CA 92106

info@yachtfinders.biz

www.yachtfinders.biz

(619) 224-2349

Toll Free (866) 341-6189

LEADER IN  
BROKERAGE SALES  
ON THE  
WEST COAST!



**48' GARCIA CUSTOM, '90** \$310,000  
Fin keel and spade rudder greatly enhance her sailing performance, as well as making her a very maneuverable boat under power.



**47' BENETEAU FIRST 47.7, '02** \$197,500  
Three-cabin layout is well thought out for any cruiser, and the performance will excite any racer! Equipped to cross oceans!



**45' TRITON PACIFICA, '74** \$69,000  
This heavily constructed cruiser allows a family or group of friends to sail and move about without falling over one another.



**43' GULFSTAR CC, '79** \$59,900  
*Leonore* has been in Florida, the Caribbean and Hawaii, as well as many places here in sunny California. At our docks.



**40' HUNTER LEGEND 40.5, '93** \$93,500  
One of the roomiest 40-footers ever built, this two-owner Hunter has been a local Southern California boat and is well cared for.



**40' VALIANT, '82** \$117,000  
Excellent sail inventory, watermaker, solar panels, ground tackle, electronics, spares, refrigeration, tankage, and windvane.



**38' ENDEAVOUR, '84** \$59,000  
*Serenity* is that rare find: she has her original owners, who have given her extraordinary care and love since her launch.



**38' HUNTER 380, '99** \$94,900  
Engine has been replaced recently (with more horsepower!), plus roller furling main and jib, and renewed salon cushions.



**36' CATALINA, '90** \$58,500  
The successful Catalina 36 combines the elements of a luxurious interior, an efficient deck plan, and outstanding performance.



**35' CONTOUR 34/35 TRI, '05** \$123,000  
Modern sail-handling systems with bow sprit, roller furling/self-tacking headsail, integrated lazy jacks, and full-batten main.



**34' HANS CHRISTIAN, '77** \$47,500  
Roomy, well laid out interior and beautiful woodwork. Add electronics or navigate traditionally. Classic-looking tanbark sails.



**32' CATALINA 320, '04** \$99,000  
Very clean and tidy Catalina 320 shows as near new. Tabernacled mast, Raymarine E80 chartplotter/radar and autopilot.

## Custom Canvas & Interiors



The Gianola Family has been designing and fabricating custom canvas and interiors since 1969. Gianola Canvas Products offers you the best in quality, more choices, and personal service.



265-B Gate 5 Road  
Sausalito, CA 94965  
(415) 332-3339  
www.gianolacanvas.com



**Your Discount  
Safety Source!**



### Hydrostatic Inflatable PFD with Harness

- 1F automatic hydrostatic inflator with manual backup
- No inflator maintenance required for 5 years unless fired
- USCG Type II (Commercial Type V)
- 35 lbs. of buoyancy when inflated

Item 552291

Model MD3184

List \$342.64

Available in Carbon/Black, Red/Black or Pink/Black

**ONLY \$239<sup>99</sup>**

**MOST ORDERS PLACED BY 4PM SHIP THE SAME DAY!**

**Defender**  
www.defender.com • 800-628-8225

The Brands You Want and Trust in Stock for Less!





## WE'LL MAKE SURE YOUR CAR DOESN'T GET JEALOUS.

We not only make sure your boat has a perfect berth at the only full-service harbor, located in Sausalito, we also provide ample parking for your car. We have the only fuel dock in the area, numerous on-site businesses, and a friendly staff who oversees it all. To find out more give us a call at 415 332 3500 or visit our website for more details.

**CLIPPER**  
YACHT HARBOR  
[www.clipperyacht.com](http://www.clipperyacht.com)

**CLIPPER**  
YACHT HARBOR  
310 HARBOR DRIVE

## LETTERS

### ↑↓THEY'RE ALL GOOD PLACES

The closest I have ever been to the Caribbean is doing the Miami-Nassau Race many years ago. But Rick Meyerhoff of Marin, one of my customers I knew from a former life, has invited me to come sailing with him in the Caribbean aboard his LaFitte 44 *Maya* — if I can find the time. He will launch his boat in Grenada in November, and then just cruise the Caribbean until the onset of hurricane season in about July. If I can find 10 days or so, what would be the best area with respect to good sailing, good people, good places to visit, and so forth? And from where it is reasonable to fly in and out?

Chris Boome  
Burlingame

*Chris — Nassau in the Bahamas is actually in the Atlantic, a long way away from the Eastern Caribbean. Everybody on the West Coast makes the same mistake — except for those who have tried to sail from the Bahamas to the Eastern Caribbean.*

*December and January are when most people sail in the Caribbean, but they do that because that's when the weather is so crappy in the States and people get time off from work. Alas, that's when the Christmas trades blow the strongest in the Caribbean, and they often blow hard for weeks without stopping. Seriously. Some guy flicks on the Azores High in mid-December, and it blows like a huge fan day and night until the guy turns it off two months later.*

*Generally, the weather improves with lighter winds — 15 to 20 knots — and smaller seas starting in early February. That's why *Doña de Mallorca* and the *Wanderer* wait until then to open the Caribbean office of Latitude, and keep it open until early May. The Eastern Caribbean weather doesn't get bad — meaning really hot and humid — until July.*

*We're not sure how far north Rick is going to cruise this winter, but here is a general guide for you:*

*The British Virgins offer the easiest sailing, thanks to flat water and countless places that cater to the charter fleets. But Rick might not want to go that far north. Furthermore, the British Virgins can be very crowded in season, and it might seem awfully structured to some. That said, there are good reasons that the British Virgins are to charter sailing what Vegas is to gambling.*

*Our favorite area of the Caribbean, as all Latitude readers know, is tiny St. Barth, which is atypically clean, safe, and full of characters. We won't even mention the very skinny and stylish French girls who stop by the pâtisseries for coffee, croissants — and everyone's viewing pleasure. St. Barth is mostly our favorite because we bought Big O there in '85, and over time have become dear friends with many of the residents. If you stay on a boat, St. Barth doesn't have to be that expensive. You don't need a car, you're surrounded by the great yachts of the world, and the anchorages and beaches are wonderful. St. Barth is close to St. Martin and Anguilla, which have great cruising, too.*

*Antigua's historic English Harbor is another big boat yachting center, and the island has a beach for every day of the year. There is fabulous sailing as you reach past Cades Reef and get into the lee of the island, and as with all the islands of the Eastern Caribbean, there is excellent diving.*

*Guadeloupe and Martinique are huge sailing bases for the French, and have plenty of attractions. But the islands are expensive, there can be a bit of a language barrier, and except for Guadeloupe's *Îles des Saintes*, which are very crowded, there isn't much that other islands don't have.*

*Some of the lesser known islands are fabulous, too, such as St. Lucia, St. Vincent and all the little Grenadines, and*

# COME VISIT COYOTE POINT MARINA

*The Peninsula's Complete Recreational Destination!*



## **BERTHING**

- Slips to 40' available
- Inside ties from \$100 per mo.
- Multihull side ties available
- Check out our rates!



## **FUEL DOCK & PUMP OUT**

- Open 7 days per week
- Gas and diesel available
- Check our prices
- Free pump outs

**Fuel Dock  
currently closed  
for repairs.**

COYOTE POINT MARINA ~ 1900 Coyote Point Drive • San Mateo

**650.573.2594**

## **Ventura Harbor Boatyard**

*"For All Your Haul Out Needs"*

**Two Travelifts  
Haul Outs to 160 Tons  
Full Line of Marine Services**

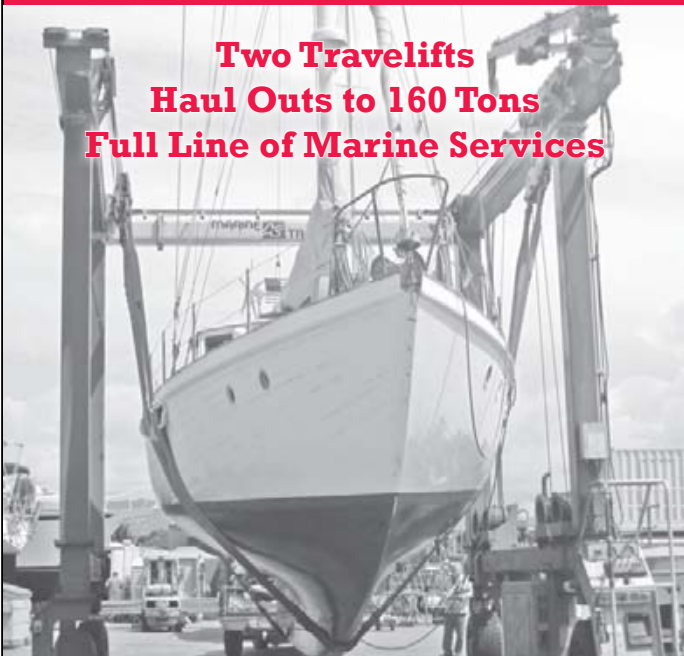

**(805) 654-1433** [www.vhby.com](http://www.vhby.com)  
1415 Spinnaker Drive Ventura CA 93001



**WE HAVE OVER 170 BOATS FOR SALE**

**VISIT OUR WEBSITE:**

[www.mazmarine.com](http://www.mazmarine.com)



**TOLL-FREE**

**MAZATLAN:**

**1-855-892-2487 or 1-8558-YACHTS**

**LA PAZ:**

**1-855-225-2729 or 1-855-22-LAPAZ**

**SAN CARLOS:**

**1-855-846-7245 or 1-8558-GOSAIL**

**PUERTO VALLARTA:**

**1-855-789-2248 or 1-855-PVYACHT**

Tired of being

**COLD AND WET?**

Get some protection from wind and spray!

**SAIL in COMFORT**

with a dodger from Cover Craft



All sewing in Tenara thread.

- Classic dodgers and biminis
- Drop-top folding dodgers
- Custom canvas for sailboats

560 W. Cutting Blvd., #2  
Richmond, CA 94804  
Inside the KKMI boatyard

**(510) 234-4400**Quality  
Yacht  
Canvas**LETTERS**

Grenada. But things are markedly more primitive and slower paced 'down island'. Not bad, mind you, just much slower and less developed. So where you should go all depends on what kind of experience you want.

If you want the most mellow time with the easiest sailing, we'd recommend the British Virgins. If you're more adventurous and don't have a problem with open ocean sailing, we'd try to meet Rick at St. Martin and kick around there and Anguilla, and spend most of the time at St. Barth. If you could pick any time to do this, we'd go during either the St. Barth Bucket, the greatest sailing spectacle in the world, or the Voiles de St. Barth, which is smaller, but nonetheless totally French sailing and partying fun. The beauty of going during either of these events is that you can choose to enjoy great partying at the quay next to many of the great yachts of the world, or you can motor about three miles to the Columbie anchorage, where there are not only no roads or houses, but no lights either. If you want the 'path less travelled', sail down-island with Rick. But the truth of the matter is that if you can't have fun sailing anywhere in the Caribbean, you've got a serious problem.

It's not that hard to get to any of the islands of the Eastern Caribbean. From the Bay Area, you fly to either Miami or New York, then get connections to the bigger Eastern Caribbean islands. If you want to go to the smaller islands, there are fewer flights, and you will probably have to go through Puerto Rico or St. Martin, which may cost you a day of sailing fun. Flying between the islands of the Eastern Caribbean — even many of the bigger ones — is often difficult if not impossible, and it's always expensive. So plan carefully.

↑↓ **PIRATES IN MEXICO?**

I appreciated your recent editorial response to a letter regarding cruiser safety and Mexico. In that response you wrote, "As we reported last month, we can't recall a case of a violent attack on a cruising boat in Mexico in decades. When we asked our readers last month, they couldn't either. If anyone has evidence to the contrary, we stand ready to be corrected."

Well, I would like to remind the sailing community of Alameda sailor John Long, who was killed off of the coast of Southern Mexico in '08. And I would encourage the sailing community to read David Vann's moving piece, *Last Voyage of the Culin*, which is about the incident. It appeared in *Outside* magazine, which can be found at [tinyurl.com/8m6yppy](http://tinyurl.com/8m6yppy).

Perry  
San Francisco

Perry — We're very sad to hear about the death of John Long, and wish we'd been told about it earlier.

We'll gladly alert our readers to that incident, and to the article in *Outside* magazine. But frankly, we hardly know what to make of it, especially when Vann claims that Long "was killed" as opposed to simply having died. After all, Vann's tale not only is colorful, but also seems to be full of exaggerations, embellishments, admitted speculation, and what we find to be questionable conclusions. Speaking as an editor, it seems to us that *Outside* went hook, line and sinker for a sensationalized bit of writing, assuming few of their readers knew anything about sailing in Mexico.

Consider, for example, the following paragraph: "The truth may be elusive in other places, but here in Puerto Madero and La Cigüena, I believe it never actually exists. Even as events occur, they immediately become something else. An outsider can never know anything for certain, and this is partly because we are mythological creatures, born of conquistadores and sit-



**Marine Mechanical Repair**  
**Electrical Repair & Upgrades**  
**Installation Specialists**  
**Full Service Shop**

**BETA MARINE WEST**

Engineered to be  
serviced easily!

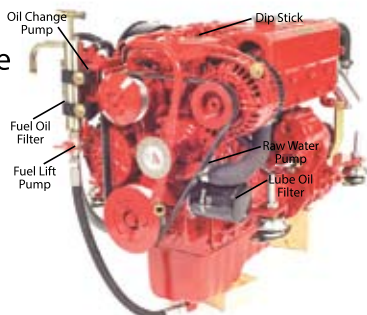

**SUZUKI** Dealer for Suzuki  
**MARINE** Outboards

400 Harbor Drive, Sausalito, CA 94965

**(415) 332-3507**[www.betamarinewest.com](http://www.betamarinewest.com)[www.hirschfeldyacht.com](http://www.hirschfeldyacht.com)



# Think Style!

We can build your racing yacht, or your rowboat!



## Berkeley Marine Center

The yard that works for you!

In Berkeley Marina

510-843-8195

www.berkeleymarine.com



## VALLEJO MARINA



Gateway to the Bay & Delta

### The North Bay's Only Full-Service Marina!

- Slips starting at \$6.79 per foot!
- Concrete and Wood docks
- 23' enclosed storage units available
- Night security guard



**(707) 648-4370** • Fax (707) 648-4660

42 Harbor Way • Vallejo, CA 94590

www.ci.vallejo.ca.us marina@ci.vallejo.ca.us

## Ultra Security.



Ultra Anchor is certified by the American Bureau of Shipping (ABS) to meet their highest level of holding power for use on ABS class vessels. SHP certification is awarded to anchors with superior holding power of at least four times that of ordinary anchors.



Ultra Flip Swivel

See us at the -  
St. Petersburg Boat Show, 11/29 - 12/2  
Toronto Boat Show, 1/12 - 1/21



8700 Warner Ave. Suite #160 Fountain Valley, CA 92708  
www.ultraanchors.us • sales@quickline.us • 714 843-6964

Home of the Ultra Anchor & Ultra Flip Swivel





Intrepid Landing  
*America's Cup Harbor*

### San Diego's Newest Marina

On Shelter Island close to all amenities, from boat supplies to restaurants and markets.

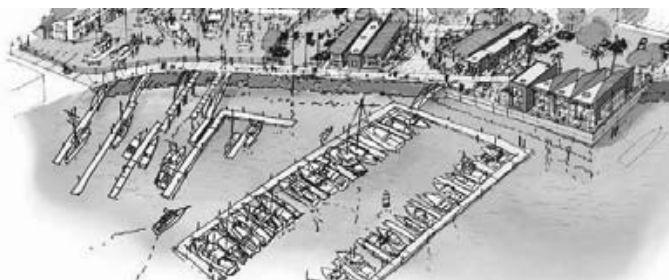

- Liveaboards \* Deep Water Docks
- Slips for 30'-220' Yachts \* 480v/3 Phase Available
- Free Wireless \* Cox TV/Internet

[www.IntrepidLanding.com](http://www.IntrepidLanding.com)

2700 Dickens St. | San Diego CA 92106 | P: 619-269-7300

## Captain's License

Maritime  Institute

### Captain's License Training

Maritime Institute has a course Near You!  
From *San Rafael* to *San Diego*  
or *On-line* at your own pace

- ✓ OUPV up to 100 GT
- ✓ Able Seaman
- ✓ Radar and Radar Renewal
- ✓ FCC License Exam - MROP  
Marine Radio Operator Permit

**Toll Free: 888-262-8020**  
**[www.MaritimeInstitute.com](http://www.MaritimeInstitute.com)**

## LETTERS

ting on our mountain of gold in El Norte. We aren't believable ourselves, even our existence, so we're told stories, and every story is about one thing: money."

We're pretty open-minded as an editor, but we'd have suspended Vann's poetic license for at least six months for writing stuff like that. Furthermore, it doesn't sound anything like the coast of a country we've visited countless times with our own boats over a period of 30 years.

Mind you, there is no doubt that Vann knows something about Puerto Madero, for he writes about his misadventures with his own boat there 15 years ago:

"My sailboat was a 48-ft ketch, just like Long's, and in the late fall of 1997 I hired another captain to deliver her from San Francisco to Panama while I finished a semester of teaching at Stanford. My plan was to pick up the boat in Panama and continue to the British Virgin Islands, where I would run winter charters. This boat, Grendel, was my business and my home.

"But the captain I'd hired, an accomplished sailor in her thirties, took on some bad diesel in Acapulco, diesel with water in it, and limped into the town of Puerto Madero on a bit of wind. For some reason, she waited a week before calling me. Then the cook took off on another boat for la pura vida in Costa Rica, and took my \$2,000 in emergency cash with him."

It would have been helpful had Vann identified his accomplished female skipper, as it would have allowed us to ask her



PHILIP LONG

'Ascension of John Long' is a piece of art created by his son, Philip Long.

why she supposedly waited a week to call him about the boat's problems, and generally get her version of the events that took place. Anyway, when Vann got down to his

boat in Puerto Madero, things were grim. Really grim:

"My sailboat was large and broken, tied to the one crumbled chunk of concrete on the shoreline, visited by rats, snakes, begging children, prostitutes, the police, the navy, drunken fishermen, and the crooked port captain's men. At first I tried to have the engine fixed, but a mechanic with a disco shirt, gold chains, and a group of thugs at his shop held the high-pressure injection pump for ransom, demanding \$900 instead of \$100 for the repair. So I tried a new tack, spending \$3,500 to buy a used engine and have it trucked down from California. This engine was stolen before it ever arrived, only to reappear mysteriously months later, a 500-lb hunk of metal dumped on the beach in the middle of the night."

Nothing but rats, snakes, begging children, prostitutes, the police, the navy, drunken fishermen, and the crooked port captain's men — do tell! We find this description to be just a wee bit dramatic, even for Puerto Madero, which admittedly was for a long time the most corrupt port on the Pacific Coast of Mexico. It's now home to the new Chiapas Marina, which we're told is being run by the much-liked former harbor master at Huatulco.

We also find it interesting that in the 35 years we've covered cruising on the Pacific Coast of Mexico, we can't remember anyone — but Vann — using the incendiary word "pirates" in Mexico. Pirates who Vann claims sometimes transport drugs nearly 2,000 miles up the Pacific Coast to California in pangas powered by 115-hp outboards. Boy, their asses must be sore

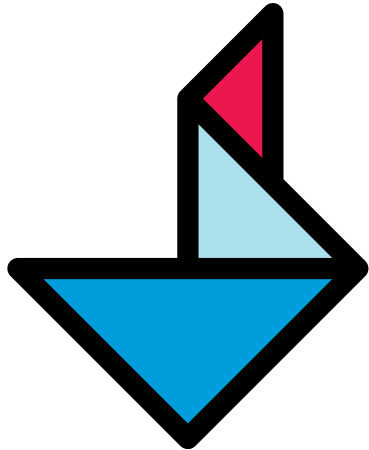

## SAN FRANCISCO BOATWORKS

San Francisco's boatyard | [sfboatworks.com](http://sfboatworks.com)

Marine parts and supplies



Complete haul and repair



Engine repair and service



**Contact us for seasonal  
discounts & special offers**

Authorized dealer for:

**YANMAR**

**marine services  
for power & sail**

415.626.3275

[info@sfboatworks.com](mailto:info@sfboatworks.com)

835 Terry Francois St.

San Francisco, CA 94158



## RICHARDSON BAY MARINA

formerly Kappas Marina

**MODERN FACILITIES IN A WELL-PROTECTED HARBOR**

**Concrete  
Dock System**

**Well Maintained  
Facilities**

**Beautiful  
Surroundings**

- DEEP WATER BERTHS:  
BASIN AND CHANNEL  
DREDGED
- CARD KEY SECURITY SYSTEM
- DOCK CARTS
- PUMP OUT STATION
- AMPLE PARKING
- CLEAN SHOWER AND  
TOILET FACILITIES
- WITHIN WALKING  
DISTANCE: MARKET/DELI,  
LAUNDROMAT,  
RESTAURANT
- AT EACH BERTH:  
LARGE STORAGE BOX,  
METERED ELECTRICITY,  
PHONE HOOKUPS, WATER

**BERTH YOUR BOAT IN SAUSALITO**

415 332-5510 [www.richardsonbaymarina.com](http://www.richardsonbaymarina.com)  
100 Gate Six Road, Sausalito • Fax 415 332-5812

## HANSEN RIGGING

510.521.7027

- Wire, Rod and Composite Standing Rigging built in-shop
- Quality Lifelines measured and installed
- Mainsheet systems that are easy to use
- Improved Jib and Main Boom Furlers sold and installed
- Running Rigging sold and spliced
- Halyards that do not Stretch
- Custom Masts and Booms built by Experienced Craftsmen.
- Boom Vangs, Reefing systems and Outhauls that work!
- Heavy Weather Preparation
- Proven Tuning Techniques
- Insurance Estimates
- Rig Inspections

A substantial amount of our time is used working with our customers, understanding what they want to accomplish. Call us first and you will get the best value for your investment, guaranteed.

2307 Blanding Avenue, Suite G  
Alameda, CA 94501

[www.hansenrigging.com](http://www.hansenrigging.com)

**GOLD COAST YACHTS**  
U.S. VIRGIN ISLANDS



**THE LEGEND CONTINUES**

**106 CUSTOM BUILT MULTIHULLS**

- Composite Yachts • Short Build Cycles
- Competitively Priced

[www.goldcoastyachts.com](http://www.goldcoastyachts.com)

**Check out our "Must-See" website!!**



**The Iverson's Dodger is now available in the Bay Area!**

Dodgers • Bimini Tops • Enclosures



206-849-2274

[www.iversonsdesign.com](http://www.iversonsdesign.com)

## LETTERS

when they get to the States.

The other thing that gives us pause with regard to the veracity of Vann's speculations was the 78-year-old Long's physical and mental condition at the time of his death. Long is said to have been in such poor physical shape that he could hardly climb the bleachers at baseball games. As for his mental abilities, Vann reported that Long twice left San Francisco and turned north, somehow thinking that Tomales Bay was on the way to Mexico.

Vann speculates that Long was the victim of an attack by 'pirates'. It's possible. But we're skeptical. Very skeptical.

### ↑↓ NOT WILLING TO RISK LIFE AND LIMB

To a prudent sailor, aggressive sailing and poor seamanship are one and the same.

While on a Crewed Farallones Race about 35 years ago, I experienced both aggressive sailing and poor seamanship. We were just outside breakers in strong winds and big seas, when suddenly the Farallones became so enveloped in fog that we couldn't see them. Our best crewman suggested to the owner that we come up in order to clear the island safely, but the owner ignored that advice. We all quit the boat after that race.

I had raced in the Bay and offshore many years before that race, but I realized that I was not willing to risk my life and limb so some owner could feel like a winner.

Arthur D. Saftlas  
Larkspur

Arthur — We totally empathize with your not wanting to have your life in the hands of an owner/driver who you think is operating whatever vehicle you're on — be it a sailboat, a car or an airplane — in a reckless manner. We can't remember being in that situation on a boat, in part because we're semi-control freaks who rarely like to sail on boats other than our own, but it's happened to us a number of times when we were in cars or taxis. And we've never hesitated to get the heck out of the car, no matter where we were. We've felt so strongly about control over our lives, and those of our kids, that we made sure they got cars as soon as they turned 16. The last thing we ever wanted to happen was for them to be injured or killed as a result of being in a car operated foolishly by some reckless friend.

The problem with boats, of course, is that you can't just get off them anytime you feel they are being operated dangerously. So it's important that crewmembers, owners, and skippers all be on the same page when it comes to what level of risk-taking they want to engage in. The longer and rougher the sail, the more important it is to be on the same page.

We disagree, however, with your assertion that aggressive sailing is necessarily the same as poor seamanship, in part because those are subjective terms. For example, some sailors believe that good seamanship means that you should always reef the main and take down the spinnaker at night. But to many sailors, and particularly experienced racers, keeping the main and spinnaker up at night in moderate and even fairly strong conditions is neither aggressive nor poor seamanship. Of course, much depends on one's age and sailing experience, the type of boat, skill of the driver and crew, and so forth.

The nice thing about sailing is that you can pretty much pick the level of risk you want, based on what and where you sail, and with whom you sail. After all, the risk level is considerably lower when sailing in a non-spinnaker division of a beer can race on the Oakland Estuary than it is doing something like the Doublehanded Farallones on a Moore 24.

*Come Visit Us Today!*

# SOUTH BEACH SAILING CENTER

at the  
beautifully renovated Pier 40 in San Francisco

## **South Beach Riggers**

**DO IT ONCE.  
DO IT RIGHT.  
PERIOD.**

**415.331.3400**

[www.SouthBeachRiggers.com](http://www.SouthBeachRiggers.com)

**Come see us in Sausalito**

**399 Harbor Drive  
Sausalito, CA 94965  
9 am-5 pm M-F**



**New cushions for the holidays? Order now!**

**NORTH  
BEACH  
MARINE  
CANVAS**

**Custom Yacht Upholstery!**

[nbmc@earthlink.net](mailto:nbmc@earthlink.net)  
[www.northbeachmarinecanvas.com](http://www.northbeachmarinecanvas.com)

**415.543.1887**

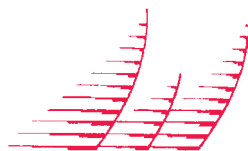

## **Westwind**

**Washing • Waxing • Varnishing**



*The boat looks  
beautiful...  
thanks!"*

*- Jan Kaprielian  
Sea Ray 36  
Vera Jean II'*



**(415) 661-2205**

*Serving the entire Bay Area for more than 25 years*

Pier 40, South Beach on the Embarcadero • San Francisco

Call Toll Free **888-828-6789**

[westwinddetailing@sonic.net](mailto:westwinddetailing@sonic.net)

[www.boatdetailing.com](http://www.boatdetailing.com)



Adjacent to South Beach Harbor and AT&T Park • Close to dozens of fantastic restaurants and shops

## SAUSALITO

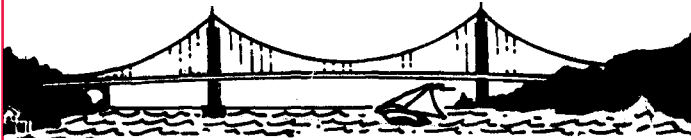

# LIST MARINE INC.

- Full service engine shop
- We service all makes
- Dockside facilities
- Mobile service trucks

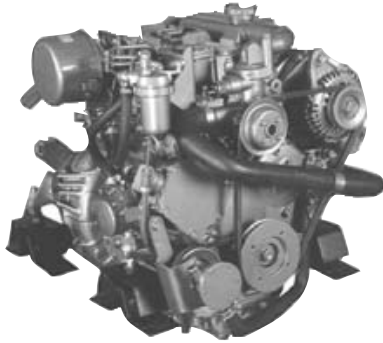

**YANMAR**  
marine

P.O. BOX 2008 / 69 LIBERTY SHIP WAY • SAUSALITO, CA 94966  
Adjacent to Schoonmaker Pt. Marina

**415•332•5478**

**www.listmarine.com**

## SAN DIEGO/SAN FRANCISCO STORAGE

*Keep Your Boat High and Dry!*

**CUT  
SLIP FEES!**

### IDEAL FOR:

- Long term storage & savings
- Do-it-yourself work yard

### NOW OFFERING A MOVE-IN SPECIAL

With a one-year storage contract, we will amortize the cost of haul-out and transport over the course of one year.

- 24-HOUR SECURITY •

Call for rates or reservations

**(800) 660-8132**

**www.sandiegoboatmovers.com**



6996-A Mission George Rd.  
**San Diego, CA 92120**  
205 Cutting Blvd.  
**Richmond, CA 94804**

**START SAVING TODAY!**

## LETTERS

### ↑↓ SPEAKING OF GRAND OLD SAILING YACHTS . . .

Thanks for the interesting article on the Phil Rhodes-designed 90-ft motorsailer, *Sea Diamond*. I'm Phil's grandson,



LATITUDE / RICHARD

*'Sea Diamond's nameplate seems inferior to the rest of this classic beauty.*

so I read the article with interest, in part because *Sea Diamond* was my favorite of his designs. But I was curious about the caption you had for the photo of the original nameplate, which read, "Oddly enough, the only slightly cheesy thing on the great

yacht is the original nameplate." Why was it cheesy?

I loved the information in the article and the fabulous photos. I hope to get a glimpse of her at the shipyard in Newport, Rhode Island.

Doug Harrison  
Stamford, CT

*Doug — You're a little behind the times, as we recall that article ran a couple of years ago. But no worries, we're glad you liked it. Our remark about the nameplate was not to suggest that a nameplate is a cheesy thing, but rather that the quality of the nameplate on Sea Diamond seemed inferior of the rest of the yacht.*

### ↑↓ WE WERE SAD TO DROP OUT OF THE TA-TA

When *Latitude* introduced the idea of a SoCal Ta-Ta, my wife and I realized that it would be the perfect vehicle to kick ourselves in the ass and get moving to make ourselves and our boat ocean worthy, and to gain more practice for the family cruising adventure we hope to start in the near future. So we signed up and got to work. We got the radar working, we tweaked the watermaker into shape, and we sailed around the Farallones and up to Drakes Bay on a blustery 25-knot weekend. *Family Circus*, our Fontaine-Pajot 35 catamaran, shined the whole time we were on the water. We even made our first boat flag and had plans for making a Ta-Ta pennant.

We decided to head down to Southern California early, as I couldn't take enough time off work to do the delivery and the Ta-Ta all at once. Then we did final engine checks, and unfortunately discovered our port engine was starting to lose compression and thus wasn't doing so well. We decided that we'd nurse it down to Southern California for the Ta-Ta and back, then get the engine overhauled upon our return.

Alas, as we entered Monterey Harbor to refuel — there was no wind the first 12 hours out of the Gate — we couldn't bring the engine to life. Faced with a difficult decision of where to have the major engine work done, and what adventures we could undertake safely with all our kids aboard during the event, we decided that we had to abandon our hopes of doing the Ta-Ta. So we returned to San Francisco Bay under one engine.

What made it worse was that our kids had just learned that you had given the Ta-Ta a 'Reggae Pon Da Ocean' theme. They were totally into it! In fact, they even asked if we could charter a boat for a week so we could still take part.

So even though we didn't get to do the Ta-Ta, signing up for it did so much to further our progress toward our cruising goal. We hope to join *Latitude* on a future adventure, and

# EXCEL UNDER PRESSURE

When nerves are as taut as sheets it's reassuring to know that Doyle sails are taking the pressure.

Consistent wins in major events show that Doyle Stratis sails convert pressure into winning performance.

Whether you sail a skiff or a super-yacht, Doyle's latest generation of sails redefine performance sailing.



# STRATIS



SPC-1045

Doyle San Francisco  
Bill Colombo  
510-523-9411

Doyle So. California  
Bob Kettenhofen  
949-645-5388

[www.doylesails.com](http://www.doylesails.com)

## BLUE WATER YACHT INSURANCE

Blue Water Yacht Insurance covers more active cruising boats than any other marine agency in the Western Hemisphere.

### Our Insurance Programs Provide:

Crew of two anywhere • Worldwide Navigation  
Charter Boats • Multihulls • Liveaboards • Racing Boats

### Quality Rated Insurance Companies

Boats aged 1 to 40 years • "Agreed Value"  
"All Risks" • "New for Old" replacement partial losses  
Hulls valued \$50,000 to \$25,000,000

### Worldwide Health Insurance

International and USA health insurance plans  
at affordable prices.

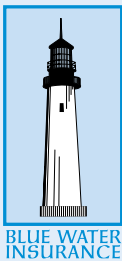

Call Toll Free (866) 463-0167

Fax (866) 795-3707

[sales@bluewaterinsurance.com](mailto:sales@bluewaterinsurance.com)

Quote requests

Visit our website

[www.bluewaterinsurance.com](http://www.bluewaterinsurance.com)

## SAN DIEGO'S RIGGING CENTER

since 1983



Proudly serving for over 25 years

Safe, cost effective,  
professional rigging solutions.

*We'll get you ready for your next  
sailing adventure!*

Design consulting • Commissioning  
Refits • Custom line and hardware

WE SHIP  
RIGGING  
WORLDWIDE

619.226.1252

[www.pacificoffshorerigging.com](http://www.pacificoffshorerigging.com)

# ULTRA SMALL CABIN AND WATER HEATER

## DEPENDABLE COMFORT

Be comfortable all year round with a quiet, reliable Webasto hot water heating system. Can be linked to pre-heat an engine and provide all the hot water you'll need in the galley or for showers.

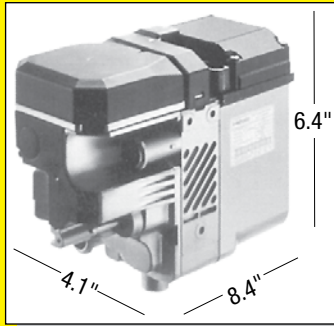

**Webasto**

## CERAMIC IGNITION SYSTEM

- Heat output 17,200 btu/hr (5kw)
- Fuel Consumption .18 gal/hr
- Power Consumption 32 w
- Weight 6.4 lbs

CALL FOR MORE INFORMATION



**SWEDISH MARINE**

1150 BRICKYARD COVE RD., SUITE B6  
PT. RICHMOND, CA 94801 (510) 234-9566

# Direct benefits

It's easy! With your new sail order from *North Sails Direct* you measure, you SAVE, you get the best. *Contact us today!*

**FREE!**  
**ONE YEAR SAIL CARE & REPAIR**  
with purchase of a new North sail\*

\*Restrictions may apply. Ask your North Sails Direct representative for details.

**NORTH SAILS direct**



northsailsdirect.com or call 888-424-7328

Boat size restrictions may apply.

## LETTERS

hope the fleet had a good time.

Chris Tzortzis  
Family Circus, Fontaine-Pajot 38  
San Francisco

Chris — We're sorry that your family wasn't able to make it, as we think we can safely say that the Ta-Ta turned out to be a pretty enjoyable event. But we're glad it helped you get off the dime with respect to preparing you and your boat for an upcoming cruise. By the way, did you realize that next year's Ha-Ha is going to be the 20th?

### WE HAD BOTH FULL-SIZE AND FOLDING BIKES,

*Latitude* asked what bikes are best for cruising boats. I had a pair of full-size mountain bikes aboard my Deerfoot 62 *Moonshadow* during our '94 to '11 circumnavigation. They got a lot a use and really added to the experience. When we sold the boat earlier this year, we left the bikes aboard so John and Deb Rogers of San Diego, the new owners, are enjoying them now.

After selling *Moonshadow*, we went to the dark side — for cruising anyway — and bought a Mainship 39-ft trawler near Baltimore. Because space is very limited, I picked up a couple of folding bikes from an online store — and Merima and I couldn't be happier with them. We spent a couple of months cruising down the Intracoastal Waterway, and are now in Ft. Lauderdale. The bikes got — and still get — a lot of use. While not as fast and stable as full-size bikes, the folding bikes are easier to store and handle. We took them out almost every time we stopped at a marina. They look pretty cool and get a lot of compliments.

We're now waiting for a ship to take our boat — and our bikes — home to Auckland next month.

George Backhus & Merima Dzaferi  
Jolly Mon, Mainship 39

Lying in Ft. Lauderdale / Auckland / Formerly Sausalito

### TEN YEARS OF SATISFACTION

We have a pair of Montague folding bikes for our boat that we bought in December of '02, and we absolutely love them! They are full-size mountain bikes, and we have logged a lot of miles on them throughout Hawaii, Alaska, and many South Pacific islands.

Some of the islands that we visited — such as Niue, Wallis and Funafuti — don't have public transportation or taxis, so the bikes allowed us the opportunity to tour the islands without the expense of hiring a car. We met so many locals while riding along! On many occasions we were flagged down and invited to join in at a meal or were offered a drinking nut. The locals were very curious about us and really wanted to talk to us. It was great fun.

Another benefit of bikes is that they allowed us to explore more remote areas.

The full-size bikes make it much easier to tackle the uphill grinds, so we're glad we chose them over the smaller ones.

Emmy Newbould & Eric Willbur  
Nataraja, Dutchman 37  
Brickyard Cove

### YUM, CREOSOTE, NOT NECESSARILY A BAD THING

I'm worried about the creosote at the Army Corps of Engineers site in Sausalito. There are times when the creosote odor from the pier is so strong that it causes lung and eye irritation, as well as dizziness. It's especially bad when the Corps uses heavy equipment to break down the piles of stuff





# MODERN SAILING SCHOOL & CLUB

Sausalito, CA [www.ModernSailing.com](http://www.ModernSailing.com) (415) 331-8250

## Get Your US Coast Guard Captain's License

**Feb. 26 - March 9**

M-F, 9am - 5pm

**OUPV LICENSE - \$995**

**100 TON LICENSE - \$1195**

Our GUARANTEED, U.S. Coast Guard Approved course will prepare you for all elements of the exam, guide you through the application process, and conclude with on-site testing.

## Gain Advanced Certifications in Exotic Locations with John Connolly

**ASA 106**

**VENICE / CROATIA - 2013**



**LEG 1: April 27 - May 7 (2 SPOTS LEFT)**

**LEG 2: May 10 - 20 (1 SPOT LEFT)**

**LEG 3: May 24 - June 3 (2 SPOTS LEFT)**

Cost  
\$2450 / berth, \$4700 / cabin

### JOIN THE CLUB!

Exclusive Access to 17 Charter Boats  
Discounts on Courses  
Social Events and Mixers

**ONLY \$35  
a MONTH!**

**ASA OUTSTANDING SCHOOL 2009 & 2010**



## WE WANT YOUR BOAT LOAN



NORTHERN CALIFORNIA REPRESENTATIVE

**Bill Kinstler**  
866-486-2628

WEST COAST REPRESENTATIVE

**Max Salvater**  
888-898-2476



Visit us at...

[www.boatbanker.com](http://www.boatbanker.com)

License #OE32738

## TWIN RIVERS

MARINE INSURANCE AGENCY, INC.

"Your Boat Insurance Specialists"

7 Marina Plaza • Antioch, CA 94509

At The Antioch Marina

Private Pleasure / Commercial Risks  
Classic Yacht Programs



- West Coast
- Atlantic
- Mexico
- Hawaii
- East Coast
- Pacific
- Caribbean
- Alaska

Representing...

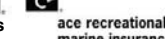
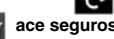

Shop Your Renewal & Save • Flexible Survey Requirements

Insurance made simple, affordable and effective.

Broad Navigational Areas • Liveaboards

Years of unbeatable experience to match your needs to the right product.

Agreed Value Policies • Fuel Spill Liability

Get an online quote: [www.BoatInsuranceOnly.com](http://www.BoatInsuranceOnly.com)  
(800) 259-5701



## McGinnis Insurance

Since 1972

**Agreed Value Policies  
Year Round Mexico, Liveboards,  
Floating Homes**



*Happy Thanksgiving!*

Call us at: **800-486-4008**

mcginnis@aol.com ☯ License #0570469

## Come Join the Fun

*Slips Available  
Up to 32 ft. Boats Only \$110/mo.*

- Special Promotion, Limited Time Offer
- We Own Our 220 Slip Marina
- Membership Required

*Call for Details!*



## Oakland Yacht Club

*Cruise, Race,  
Socialize*

In Alameda, CA

*Est. 1913*

[www.oaklandyachtclub.net](http://www.oaklandyachtclub.net)

**(510) 522-6868**

**Become a member. Schedule a tour today!**

## LETTERS

they bring in from the waters of the Bay. The particulate matter is blown across the water, and can be smelled on boats in the vicinity.

I'm concerned because creosote can cause cancer. I've contacted the City of Sausalito, but they say it's a federal issue. I contacted the Army Corps, and they said they would look at doing testing. Isn't that something they should have done before? If the Army Corps were a private business, I suspect such tests would have been required. I've contacted the BCDC (Bay Conservation and Development Commission) but they said there was nothing they could do.

If the predominant winds blew toward the many offices in the area instead of toward the water, I wonder if there would be more of a response. Do you have any suggestions on what else can be done?

C.M.  
Sausalito

*C.M. — We originally thought you were making a big stink out of a slight odor. But then we went down to the Army Corps site, and we were surprised by how strong the creosote fumes were. Nevertheless, a history of creosote, as well as an understanding of its current uses, makes us wonder how dangerous it really is. Particularly when compared to the more powerful toxins sailors are frequently exposed to.*

*Even before the chemical compound that is creosote was 'discovered' by Western scientists, it had long been the chief active component in many medical remedies around the world. For instance, it was used by Greeks in the time of Pliny, by Native Americans in the Southwest, by Caribbean and South American Indians, and throughout the Middle Ages in Europe. Creosote from wood sources such as chaparral remains a popular herbal remedy today. It was also used frequently in Western medicine, primarily as an expectorant, antiseptic, astringent, anesthetic and laxative.*

*But get this — creosote is the primary ingredient in most 'liquid smoke' food products! Shortly after the creosote chemical compound was discovered in 1832, it was found to keep non-refrigerated meats from putrefying. And many people thought it gave meat a mouth-watering smoky flavor.*

*Our conclusion is that worrying about moderate creosote fumes might be more dangerous than the fumes themselves. But who knows for sure? Unless you want to become the Erin Brockovich of creosote, we think the best short-term solution is to simply move your boat north or south, so you're not directly downwind of the Army Corps site.*

### ↑↓ A GIANT AMONG SAILING LEGENDS

I enjoyed your October 5 'Lectronic tribute to Jim Kilroy of the various Kialoas. He truly is one of the great sailors of the last 50 years.

I grew up in Newport Beach and attended junior and senior high with Dana Kilroy, one of Jim's daughters. In the mid-'60s, catamarans were just catching on on the West Coast, and as I recall, the catamaran adherents were making as many enemies as friends. It was only renegades such as James Arness of the 58-ft *Seasmoke* and Buddy Ebsen of *Polynesian Concepts I, II, III and IV*, who bought them. I should say renegades who were also actors, as Arness was the star of the hugely popular television series *Gunsmoke*, and Ebsen was a very busy actor, playing countless roles from the original Tin Man in *The Wizard of Oz* to Jed Clampett in the *Beverly Hillbillies*.

But as I recall, Jim Kilroy chartered a large cat — I believe *Alley Cat* — during a weekend of particularly ferocious Santa

*Call About Our  
Special  
Cruiser Rates!*

*San Diego's Cruiser Destination*

## Harbor Island West Marina

**620 Single Slips**

**Outstanding Central Location**

**Complimentary Wifi**

**Fuel Dock**

**Pool/Spa/Laundry**

**Deli & Restaurant**

**Package/Mail/Fax/Notary**

**619.291.6440**

[www.harborislandwest.com](http://www.harborislandwest.com)

2040 Harbor Island Drive San Diego, California 92101



**Alameda Eyes**  
OPTOMETRY

**Proud Supplier of TAG Heuer™ Eyewear**

- Advanced coatings repel sunscreen and water
- Lens color increases contrast helping you find the wind
- Polarization cuts glare

**Our high-tech prescription helps you see the mark!**

**Sailing Spoken Here**

1432 Park Street Alameda, CA 510-769-2020  
[www.alamedaeyes.com](http://www.alamedaeyes.com)



## Head North for the Holidays!

The latest sailing gear and accessories from North Sails.



**NORTHgear**

800-sail-123 ext. 653  
[www.northsails.com](http://www.northsails.com)

**\$100\***  
**OFF**

**2013  
OUTBOARDS  
JUST  
ARRIVED!**



**HONDA**



2 HP

**YAMAHA**



9.9 HP

**MERCURY**



6 HP

**Now in stock – ready for quick sale  
HURRY...OFFER ENDS NOVEMBER 30!**

\*\$100 off is valid on 6hp and above 2013 model motors only.

**Outboard Motor Shop**

1926-2012  
Your Bay Area Dealer  
For 86 Years

**(800) 726-2848**

333 Kennedy Street  
Oakland, CA 94606  
[www.outboardmotorshop.com](http://www.outboardmotorshop.com)

3003

**(510) 533-9290**

All Prices INCLUDE freight & prep, plus tax & license only.

**NAPA VALLEY MARINA =  
SERVICE**

CALL  
US  
TODAY!



- Engine repair – diesel and gas
- Shaft Alignment
- Outdrive repair
- Bottom Jobs –
- Gel Coat Repair
- **AULGRIP** Paints

**WE CAN HAUL LARGE CATS/TRIMARANS**

*California's Largest Dry Storage Facility*

**NAPA VALLEY MARINA**

1200 Milton Road • Napa, CA 94559  
**(707) 252-8011** • Fax (707) 252-0851  
[www.napavalleymarina.com](http://www.napavalleymarina.com)

**Marina • Boatyard • Chandlery • Brokerage**

Dealers for  
**YANMAR**

**Interlux**  
yachtpaint.com

Distributors for *Brownell*  
Boat Stands

**LETTERS**

Ana winds in the Newport area. It was so windy that Kilroy and his crew must have been the only ones sailing that day. Anyway, the catamaran flipped in the middle of Newport Harbor, sticking the masthead in the mud of the shallow harbor.

The catamaran remained capsized in the middle of the harbor for at least a few days, a shrine to either — pick one — failed seamanship or too much bravado. Anyway, some smart ass rowed out to the inverted hulls, which floated at least five feet out of the water, and used them as a canvas on which to paint the popular World War II slogan, "Kilroy was here!"

I was a 12-year-old paper boy for the *Daily Pilot* back then, and each day I read the paper as I folded 75 copies for later delivery via my Sting Ray bicycle. On the day after the capsizing, there was a magnificent photo of the flipped cat, sporting the slogan, on the front page of the *Daily Pilot*. I thought it made for one of the funniest pictures that I'd seen in 55 years of yachting. I would love to search the *Daily Pilot* archives for that photo. Kilroy naturally took a lot of ribbing over the incident.

As I'm sure *Latitude* is aware, many of the early California catamarans were designed by Rudy Choy of Hawaii. I attended Rudy's memorial service at the Outrigger Canoe Club in Honolulu about 18 months ago. I first met Rudy at Corona del Mar High School, where he presented a movie and lecture about catamarans a few years after the famous Kilroy capsizing. I was sent to a prep school on the Big Island for my junior and senior years, where I became a classmate of Robin, Rudy's daughter. Small world.

Cats rule!

P.S. I love *Latitude* 38.

Mark Blackburn  
[www.markblackburn.org](http://www.markblackburn.org)

Mark — Thank you for the kind words.

The Kilroy cat flipping story is interesting, because we once saw the man who introduced Kilroy to the Southwestern YC audience — our new buddy Dennis Conner — flip a cat. It was when Dennis was practicing for the catamaran-versus-Kiwi 'Big Boat' America's Cup in 1988, and Dennis and crew did a little-too-aggressive fly-by of the San Diego YC one festive weekend. After the capsizing, Dennis casually swam over to the yacht club dock, a big smile on his face, leaving the crew to deal with the cat's remains.

Chuck Driscoll of Driscoll's Boat Works in San Diego told us an interesting story about Kilroy and the building of his



LATTITUDE / RICHARD

**Doña de Mallorca rubbed elbows with sailing legend Jim Kilroy early last month.**

S&S-designed 74-ft ketch *Kialoa II*. At the height of S&S's glory, they wouldn't let just any yard build their designs, and also required an approved expert to supervise construction. S&S agreed that the yacht could be built by Yacht Dynamics of Harbor City — which was some sort of joint venture of Ken Watts of Watts Sails, Bud Gardiner, and Donald Douglas of Douglas Aircraft Corp. — but only as long as Gerry Driscoll would supervise.

Driscoll was a sailing champion several times over, and 20



**OWL HARBOR MARINA – LIKE NO OTHER.**

ISLETON, CALIFORNIA  
OFF THE SAN JOAQUIN – CHANNEL MARKER 41  
**STAY FOR A NIGHT, A MONTH, A SEASON.**

**916-777-6055**  
**WWW.OWLHARBOR.COM**



**MULTIHULL SLIPS AVAILABLE**



**\$7.00/FT • DEEP DRAFT**

**McDERMOTT COSTA**  
*insurance brokers - est. 1938*

**Commercial Operations**

- COMMERCIAL POLICIES  
Marinas, Yards, Yacht Clubs, Brokers, Shipwrights

**Pleasure Yachting**

- YACHT & BOAT POLICIES  
Offshore, Coastal, Inland and Liveaboards



Lic. #OB21939

**Bill Fowler**  
McDERMOTT COSTA INSURANCE  
(510) 957-2012 Fax (510) 357-3230  
bfowler@mcdermottcosta.com



**OPEQUIMAR**  
MARINE CENTER CENTRO MARINO

**Our Experience Makes the Difference**



High velocity pump fuel dock, 46 gals./min. • Travelift: 88 tons, 100' length, 23' beam  
Dry storage for vessels up to 300' • VHF radio ch. 68 • 24-hour security • Dock rentals  
Sales & rent of used & new boats • Full service boatyard • Do-it-yourselfers welcome

**The Most Complete Marine Center Open 365 Days**  
Puerto Vallarta, Jal. Mexico / Tel: (322) 221-1800  
[www.opequimar.com](http://www.opequimar.com) / [info@opequimar.com](mailto:info@opequimar.com)

# THIS YACHT MAINTAINED BY:

## Stem To Stern

FOR ALL CONCERNS, PLEASE CALL:  
**(510) 681-3831**

Responsibilities of the  
**In-port Captain**

Yacht Security • Cruise Preparation  
Maintenance Scheduling • Delivery Services

- Hull Cleaning
- Washdowns
- Interior Cleaning
- Detailing
- Brightwork
- Mechanical Service and Repair
- Pump-Out
- Boat Yard Set-up and Management

Check out our website for a list of all our services at  
**www.StemtoSternSF.com**  
or call (510) 681-3831

**We Take the Work Out of Owning a Boat**



### MARINE INSURANCE SPECIALISTS

**Your best source for Yacht and Boat Insurance  
tailored to your needs and competitively priced**

**We Insure:**

Sail or Power ♦ Classic or Contemporary  
Fiberglass ♦ Aluminum ♦ Steel ♦ Wood

At Heritage Marine Insurance you will find knowledgeable insurance professionals who provide superior service and the finest coverage available today.

To be sure you're getting the best insurance value please contact us for a quote.

**www.heritagemarineinsurance.com**

**800-959-3047**

Fax 860-572-5919

classics@heritagemarineinsurance.com

Program available exclusively through:



## LETTERS

years before had started numerous boatyard enterprises in the San Diego area with his brother Harlan. The only problem was that Gerry lived in San Diego, and the 100,000-lb aluminum Kialoa II was being built in the South Bay area of Los Angeles. As one can imagine, making five round-trip driving trips a week between San Diego and Los Angeles got old really fast, even in the '60s. Kilroy's solution was to buy a plane and have a pilot fly Driscoll between San Diego's Lindbergh Field and LAX every working day. After a month or so, Kilroy paid for Driscoll to take flying lessons, and Driscoll eventually made about 18 months' worth of round trips as his own pilot until the yacht was completed.

Kilroy's Kialoas seemed to be everywhere. As we mentioned, Frank Robben of Berkeley bought Kialoa II and sailed her relentlessly around the globe for 15 years before selling her to a Dutch businessman in '99. Google 'Kialoa II' and you can read all about Robben's many adventures with the yacht. Kialoa II has been totally refit twice in Turkey in the last dozen years, and is now for sale — for over \$1,000,000!

Kialoa III, of course, was the most ubiquitous of all Kilroy's yachts, and made her presence felt all over the world, first as a wildly successful racing machine, and subsequently as a cruising boat — albeit not the most comfortable cruising boat in the world. It never surprised us to see Kialoa III racing on San Francisco Bay, in Southern California, or to Hawaii. But when we sailed our Ocean 71 Big O from California to Turkey in '95, we were pleasantly surprised to tie up next to Kialoa III at a marina in Marmaris. In fact, we poached 'Big Bill', one of her Aussie crew, for the trip back across the Med and Atlantic. As mentioned before, the Palmer-Johnson-built Kialoa III is structurally in fine shape and for sale in the San Pedro area. Alas, the same couldn't be said for Kialoa V, which we saw a few years ago on the hard at La Rochelle, France, looking more than a little out of sorts. Lord know where Kialoa IV is.

*Jim Kilroy, truly a sailing legend.*

### ↑↓ YOU CAN'T SNEAK POETRY PAST US

I became involved with sailing this summer and had a blast! I mostly sailed beer cans out of Richmond YC, and I want to thank all the folks on *Gruntled*, *Lighten Up 3*, *Mirage*, and Monterey Peninsula's *Yankee*, for sharing their knowledge and love of sailing. I liked it so much, I wrote a love letter to sailing to sum up why I enjoy it so much.

[Poem deleted by publisher.]

I'm looking forward to getting out this fall and winter, and to continuing to read *Latitude*.

Linda Dayoan  
Richmond

*Linda — While it was important for us to let you express your sentiment, we've had a firm policy for the last 35 years of not allowing poetry. The problem is we simply don't like it. But if it will make amends, we hope you can join us for a sail aboard Profligate sometime.*

*In a typical month, we receive a tremendous volume of letters. So if yours hasn't appeared, don't give up hope.*

*We welcome all letters that are of interest to sailors. Please include your name, your boat's name, hailing port and, if possible, a way to contact you for clarifications.*

*By far the best way to send letters is to email them to richard@latitude38.com. You can also mail them to 15 Locust, Mill Valley, CA, 94941, or fax them to (415) 383-5816.*

Welcome to La Paz

# BAJA HA-HA

Beach Party at La Costa Restaurante  
**Tuesday, November 20<sup>th</sup>**

*mexican folk dancing  
 live music, food & drinks  
 from 4-7 pm  
 door prizes and much more  
 free for first fifty  
 2012 baja ha-ha participants  
 ¡everyone welcome!*

MARINA DE LA PAZ  
SABEEV

VISTA CORAL  
marina estates

La Paz R.C.L.

www.golapaz.com

COSTABAJA

CLUB DE YATES PALMIRA

## Southbound Solar

Affordable solar solutions for sailors.

Florida's David Blount bought our Mariner's Package and an extra 30-watt panel for his custom 27-footer.

[www.southboundsolar.com](http://www.southboundsolar.com)  
 (503) 490-3305

Welcome to La Paz!

# MARINA DE LA PAZ

FULL SERVICE MARINA

IN DOWNTOWN  
 LA PAZ

Official Sponsor  
 2012  
 BAJA  
 HA-HA

Join us for the  
**BAJA HA-HA BEACH PARTY**  
 Tuesday, November 20  
 4-7 pm

All new hardwood docks  
 Dinghy landing with potable water  
 New protective piling & sheetpile breakwaters  
 Wireless Internet · and more!

Friendly, helpful, fully bilingual staff

TEL: 011 52 612 122 1646  
 email: [marinalapaz@prodigy.net.mx](mailto:marinalapaz@prodigy.net.mx)  
[www.marinelapaz.com](http://www.marinelapaz.com)  
 Apdo. Postal 290, La Paz, 23000, Baja California Sur, Mexico

## whoops!

Ever since Oracle Team USA's AC72 catamaran was launched in August, many racing fans — and crewmembers — have wondered when and if the radical speed machine would capsize in San Francisco Bay's strong winds. They needn't wonder any longer, as the big cat nosedived and flipped on October

16 at roughly 3 p.m. just inside the Golden Gate.

"We called for a bear-away as we were out training," recalled tactician Tom Slingsby. Winds had built during the afternoon to about 25 knots, accompanied by a strong ebb. "We started the bear-away, and as the boat accelerated it pitchpoled." Per the rules established for America's Cup 34, each team is allowed only 30 days of training prior to January 31, 2013. This was the team's eighth practice day.

"When the nose went down," Slingsby continued, "the wing hit and a few guys went in the water. We were unsure if the wing would snap, so we all climbed off the boat." Fortunately none of the crew was injured, but the

crumpled wing appears to be all but a total loss. Oracle support boats were on the scene, so crew were picked up quickly, with the Coast Guard standing by also.

But with the force of the strengthening ebb — which reached a max of 5.5 knots around 5:30 p.m. — the capsized hull was swept about four miles outside the Gate before it could be righted and towed back to its base along the Cityfront, arriving early the following morning.

"There's no question this is a setback," skipper James Spithill admitted. "It's going to be a big test for this team. But . . . this won't stop us from winning the America's Cup."

The team has been conspicuously silent since the day after the capsizing. Keep an eye on *Lectronic Latitude* for updates.

— andy

## latitude's 'modest' proposal

It took the October 16 capsizing — and recovery, such as it was — of the Oracle AC72 USA 17 to make us fully appreciate just how gigantic and unwieldy these catamarans are. Actually, it wasn't the capsizing in 25 knots of wind that shocked us — at some point we all expected that to happen — but rather the video of the nine Oracle rescue boats struggling in vain to keep the askew monster from drifting a reported four miles outside the Gate on a strong ebb. "We're a little out of control here!" the video screamed at us.

Thank god nobody was seriously hurt or killed. Let us repeat that: Thank god nobody was seriously hurt or killed.

We were even more surprised by the fact that — while the capsized Oracle was still drifting out the Gate, and bits of her wing were becoming souvenirs all over the Bay — it was announced that nothing has changed, and that America's Cup 34 will continue as planned.

In the past, Oracle honcho Russell Coutts has seemed to confess that maybe they had gone a little too extreme with the parameters of the AC72s in an attempt to make the America's Cup competition more exciting. Ya think? That being the case, it crossed our minds that the capsizing of the Oracle cat, and the total destruction of her main, might signal a perfect opportunity to take a week or so to digest what has happened, what it portended for the event as planned, and

continued on outside column of next sightings page

## women's sailing

Students, instructors and volunteers celebrated the 20th anniversary of the Northern California Women's Sailing Seminar at Island YC in Alameda on the weekend of September 22-23.

"The seminars began in 1993 when accomplished sailor Linda Newland and fellow IYC club member Mary Quigley returned from a similar event in the Southland," explained IYC Commodore Kristen Sotebier. "They thought, 'We need one of these up north!'" The pair brought



ERIK SIMONSON / WWW.PRESSURE-DROP.US

The moment of no return. 'USA 17' at the beginning of her devastating pitchpole.





## seminar turns 20

the concept of women teaching women to the Bay Area, and hundreds of women have since passed through the program.

All instructors, boats, and classroom space are donated to the effort. "In response to the increasing number of recidivists and women with advanced skills, new tracks have emerged focusing on spinnakers and blue water sailing," said Sotebier. Courses included Short-handed Sailing, Diesel Maintenance, and

continued in middle column of next sightings page

## proposal — cont'd

what possible alternatives there might be.

At this stage of the game, it would be extremely embarrassing and very poor form, and create an uproar, if dramatic changes were made to the very fundamentals of the 34th America's Cup. On the other hand, would it not be even worse form and more humiliating if not even two of the 72s — and their wings — survived their trials for there to even be an America's Cup?

If we were Russell Coutts and, more importantly, Larry Ellison, we would take this opportunity to suggest an alternative to all interested stakeholders. The alternative is that the huge — as well as hugely expensive and hugely complicated AC72 cats — be scrapped

continued on outside column of next sightings page



*Ouch! 'USA 17' was swept out the Gate after her capsize, demolishing her wing sail. Above, Jimmy Spithill tried to keep his composure during the ordeal but he was understandably shaken.*

# SIGHTINGS

## proposal — cont'd

as of right now. To make up for what the other teams have invested, Larry would purchase a MOD 70 trimaran for each of the teams that has participated so far. Given the much less expensive option, other syndicates might decide to jump in.

Despite having only soft sails, these brand-new extremely high performance trimarans from VPLP have proven themselves, both when sailing across the Atlantic and in inshore races in Europe. We're talking over 700 miles in 24 hours in their first ocean race, and lots of mid-30s at other times. The MOD 70s are only two feet shorter than the AC72s, and damn near as fast, and cost a fraction of the price. And having raced across the Atlantic at 30+ knots, they have what it takes to race safely on San Francisco Bay.

Since the MOD 70s are one design with soft sails, they are com-

continued on outside column of next sightings page

## seminar

Navigation. Saturday's instruction began in the classroom, moved dockside, then sailed out on the protected waters of the Oakland-Alameda Estuary in warm sunshine and gentle breeze.

On Sunday, students could choose to race Santana 22s or venture out to the main Bay to cruise bigger boats. A little over half the group chose the latter. The remaining students got in four one design races on five donated Tunas in 8-12 knots of wind. "An awards ceremony followed with trophies ranging from plastic hand clappers to pinwheels for the team that



TH. MARTINEZ / SEA & CO.

**— cont'd**

was able to make their own wind to sail past the others,” said Sotebier.

Now going on 24, the WSS's big sister, the Women's Sailing Convention in Southern California, will be held on February 2 at Bahia Corinthian YC. Call Gail Hine at (951) 677-8121 for info or see [www.wsscya.scyaweab.org](http://www.wsscya.scyaweab.org).

Tiburón's Corinthian YC also hosts a Women's Sailing Seminar for Bay Area sailors, usually in May. Any others on the West Coast? Tell us about yours in an email to [chris@latitude38.com](mailto:chris@latitude38.com).

— chris



**We don't know about the rest of you but the sizzlingly fast one design MOD 70s, which offer huge bang for the buck, would work just fine for us in the America's Cup. And when the Cup was over, they could race them to Hawaii in 4.5 days.**

**proposal — cont'd**

paratively easy, quick and inexpensive to build — particularly when compared to the AC72s. And because the first batch was made in Europe, we're sure another dozen could be made in time for next year's slated World Series in Venice, Italy, in April and Naples, Italy, in May, and already could be in Europe for those events. After the European World Series, they could be shipped to Newport, Rhode Island, and then San Francisco, for additional World Series events in the summer of '13. That means America's Cup 34 would be postponed until '14, which is fine with us, as we think it's a much better prospect than what we're sailing toward now. And one last thing that we think every spectator would agree on — the America's Cup should be fleet racing, not match racing, which is so last-century.

Wondering if we were out of line in our thinking, we asked *'Electronic Latitude* readers what they thought about our admittedly unrealistic suggestion. Response was, as we expected, mixed. The early responses were mostly in favor, the later responses not so much. Our favorite came from Randy Repass, lifelong sailor and founder of West Marine:

"Great idea! Your whole plan makes sense to me. I say congrats to Russell Coutts and Team Oracle for coming up with a radically different and unproven AC boat, and a format in a very accessible setting. Change is great! But so is common sense. I wonder at what point the Coast Guard will not allow the 72s to sail. The MOD 70s sure look to be very exciting, safer, still very high-tech, but less expensive. And because of the soft sails are perhaps easier to sail for the vast majority of typical sailors — which would be a good thing for sailing. My only question is how much change this American's Cup round can handle. As for fleet racing instead of match racing, I agree with you. But that's even more change."

For what it's worth, of those who didn't agree with our modest suggestion of switching to MOD 70s, a number of them still agreed that fleet racing is much more exciting and interesting than match racing. If organizers want the America's Cup to become more people-pleasing, we hate to say it but the match racing will have to end up in the dustbin of America's Cup history.

And now, for a little humor. Just a couple of days before the capsizes, *Latitude's* Paul Kamen attended a 'Meet the Skippers' press event. In a post-meeting one-on-one with the great Russell Coutts — who in addition to being the most successful America's Cup skipper ever and the CEO of Oracle Racing, is also a trained engineer — Kamen asked if, since the 72s will be fully foil-borne, would active hydrodynamic pitch control eliminate the risk of pitchpoling. Coutts' flat-out assertion was, "Pitchpoling will not be a problem."

It proves once again that, when dealing with the cutting edge of technology, one should shy away from definitive statements.

— richard

**push on past la push**

Just 56 hours after sailing into Seattle on a delivery from Hawaii, I converted my hard-earned summer's wages into a Cal 2-27 named *Sirena Gorda*, which I spent two days refitting and outfitting before sailing out the Strait of Juan de Fuca to the Pacific Ocean. That's where things got interesting. Having rounded Cape Flattery and heading south down the Washington coast, we hoisted the spinnaker in a light northwesterly. But flying it off a jib halyard obviously caused some chafe because the halyard blew six hours later and the kite came back down on deck. With no spare halyard, we motored for the nearest port: La Push.

Entering the narrow channel into La Push in the dark, we were shocked to find a series of buoys strung across the channel. Shit, a fishing net! We tried to avoid wrapping the prop in the net but we

continued on outside column of next sightings page

# SIGHTINGS

## la push — cont'd

shifted into neutral too late. We tried to anchor but, with an ebbing tide and a fishing net wrapped in the prop, we were effectively stern-tied to the net. Immobile and 30 feet from a rock jetty, we called the Coast Guard. Ironically, one of their boats got caught up in the nets before another was able to free us. As we were being freed, I was cutting the fishing net with a rigging knife. I remember saying to my crew, "There are going to be some very pissed off fishermen in the morning." Little did I know . . .

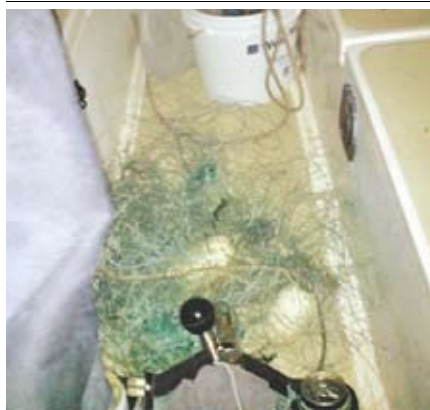

TOM WATSON

**Simpson warns southbound cruisers to avoid entering La Push due to abundant fishing nets.**

The next morning we were awakened by an angry Native American fisherman beating on the boat with a stick. "Did you cut my fucking fishing net you motherfucker?" I explained what had happened and then he threatened to kill me. I called the Coast Guard and advised them of the situation. And their response? "The natives are restless." Not quite comforted by this, we headed to breakfast at a local restaurant only to return to find a

cop and a game warden. The cop was there "for our protection" while the game warden was there to ticket the fisherman, who had apparently violated several laws. We were clearly not making any friends in La Push.

It was when another fisherman and his wife, who was holding a sawed-off, double-barrel shotgun on her lap, delivered more death threats that I decided to get the hell out of Dodge. The previous night's escapade had left *Sirena Gorda* engineless, so we just hoisted sails and shoved off. As we short tacked our way up the narrow, winding Quillayute River, the fishing fleet hurtled some of the nastiest, most profane and hateful insults and threats imaginable at us. We managed to make it back to the ocean unscathed and down to much-friendlier Newport, Oregon, where *Sirena Gorda* is currently lying.

This article is probably too late to help many southbound sailors, but hopefully it will serve others who may come later. My experience in La Push apparently wasn't an isolated incident. Several other sailors have shared similar stories with me, and I would strongly suggest that cruising yachts avoid stopping there. If you are forced to go into La Push, check in with the Coast Guard, who may be able to help you navigate in or at least shine a large light onto the channel as it frequently has nets across it.

— ronnie simpson

## leukemia cup rakes it in

"Ted Turner was the main reason we came to this event," said Discovery Bay residents Lee and Bob Allen of the 7th Annual Leukemia Cup, held October 20-21. The Allens aren't sailors — in fact they own a powerboat — and have never followed sailing in their lives. However, the excitement surrounding the America's Cup, and the fact that, decades ago they met and became fans of Turner, an opportunity arose they couldn't pass up. "We're really attracted to this cause," Bob noted, "but almost more importantly, we've been exposed to sailboat racing, and this is something we plan to follow more in the future."

Being that the race — held on the second day of the event — is just an excuse for a fundraiser, the Leukemia Cup Perpetual trophy is awarded to the top fundraising boat. This year, it went to David Joyner and Bill Nolan's Tiburon-based Melges 24 *Relentless*, which managed to plop \$58,250 into the big kitty.

continued on outside column of next sightings page

## webb chiles

A man in his early 70s losing his vision in one eye but planning to do a circumnavigation on a Moore 24 ultralight? Yeah, right.

But before you snort that this man has no idea what he's getting into, understand that he's already done five mostly (90%) singlehanded circumnavigations. And before you scoff at the notion of doing a circumnavigation on a Moore 24, understand that he's already done one with an 18-ft open boat that weighed just 900 lbs.

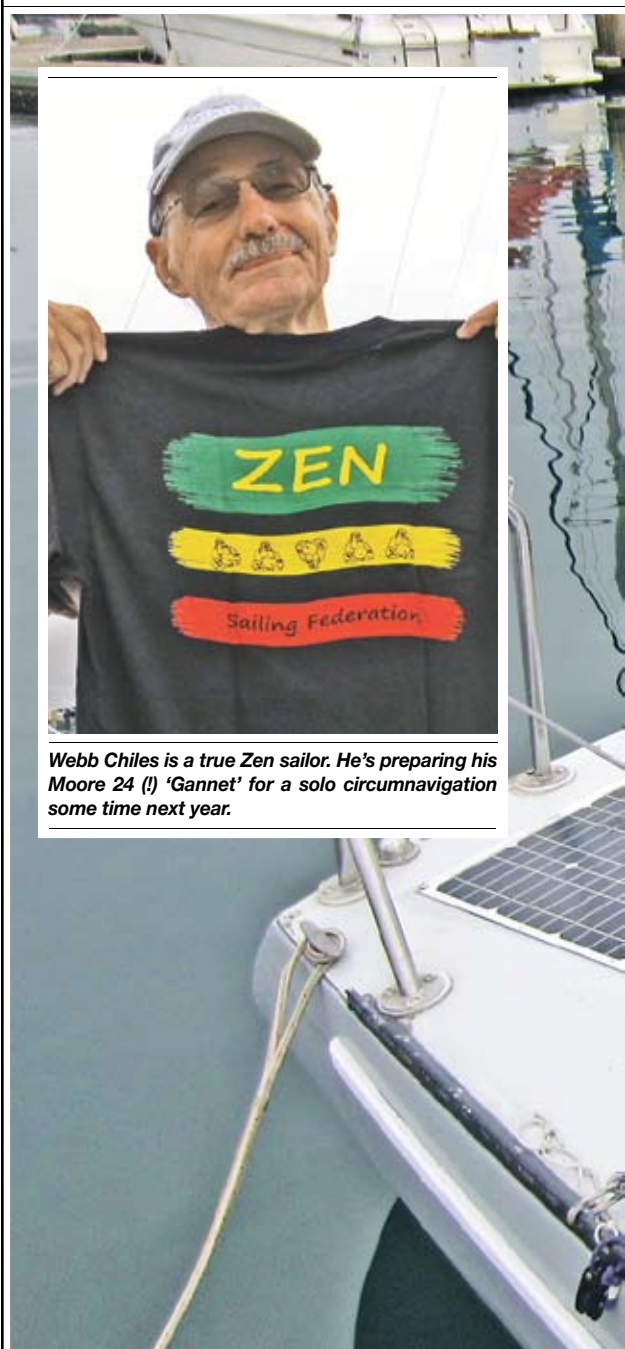

**Webb Chiles is a true Zen sailor. He's preparing his Moore 24 (!) 'Gannet' for a solo circumnavigation some time next year.**

## sneak peek

(Actually, he did one circumnavigation with two 18-ft open boats, because after the Saudi Arabians confiscated his first 18-footer and threw him in jail for a few weeks, he ultimately had to complete the voyage in a sistership.)

The man we're talking about is, of course, Webb Chiles who, although he now lives in Evanston, Illinois, bought his first sailboat, an Excalibur 26, many decades ago in Berkeley. As we were driving

continued in middle column of next sightings page

## leukemia cup — cont'd

Top individual donors were the tag-team combination of Matt Brooks and Pam Levy, owners of the S&S 52 *Dorade*, who pledged \$50,000, while Anne Feinberg claimed a respectable second place by raising \$44,000 to add to the pot.

As of this writing, this year's regatta raised roughly \$850,000, which is a bit under last year's \$1 million haul but well above 2010's total — and the numbers hadn't even been finalized.

The diverse fleet of 77 boats — from a Cal 20 to an Extreme 40 cat — ranging in age from 2 to 75 years old lined up in 11 fleets. After a delay for the westerly, PRO Bartz Schneider ran the proceedings like clockwork. In the end, conditions were gorgeous — 14 to 20 knots out

continued on outside column of next sightings page



PHOTOS LATITUDE / RICHARD

# SIGHTINGS

## leukemia cup — cont'd

of the west on a perfectly flat flood current on a clear, sunny day.

A new division for the race called the 'Classic Yachts' included Paul and Chrissy Kaplan's 55-ft S&S schooner *Santana*, the aforementioned *Dorade*, skippered by Olympian J.J. Fetter, Jim Rumer's Rhodes 48 *Copperhead* and Hank Eason's 8-meter *Yucca*. They started off the procession with *Dorade* edging out *Yucca* for the win.

The next division followed with a catamaran match race between StFYC Commodore Peter Stoneberg's Rolex Big Boat Series winner *Shadow*, a ProSail 40, and the Extreme 40 *SmartRecruiters* loaned to this writer who, if we do say so ourselves, trounced the older ProSail by over six minutes on a 16-mile course.

The contrast of old vs new, wood vs carbon couldn't have been more evident.

continued on outside column of next sightings page

## webb chiles

over to meet him at the marina in Mission Bay late last month, we didn't quite know what to expect. But after spending a very pleasant hour interviewing him, we found him to be absolutely normal — except for the fact that he seems to have an unusually clear understanding of his likes and dislikes.

For one thing, the lean and fit Chiles really likes women. Which partially explains why he's been married six times. He also really likes sailing. Not sailing to get somewhere, sailing to set a record, or daysailing, but sailing for the Zen of it. It



*Spread, 'Dauntless' wasn't the only eye-popping beauty in the Classic Yacht division. Above, the lovely crew of 'Dorade' collecting their hard-earned award.*



PHOTOS DAVID DIBBLE

## — cont'd

appeals to Chiles' sense of symmetry that if he completes a circumnavigation with the Moore, he'll have circumnavigated as many times as he's been married. Chiles also learned early on that he didn't like to work for other people, so he became an author, writing about his sailing adventures. Is it just us, or do we have a couple of things in common with Webb?

Anyway, stand by for our *Latitude 38* Interview with Webb in the December issue of *Latitude 38*. We think you'll enjoy it as much as we did.

— richard



## leukemia cup — cont'd

Other class match-ups included Thomas Akin's big blue Southern Cross 52 *Meanie* and Daniel Thielman's RP44 *Tai Kuai*, and Big Boat rivals Frank Morrow on his IMX 38 *Hawkeye* and Gerard Sheridan aboard his Elan 40 *Tupelo Honey*. In some tight racing, Thielman and Morrow both edged out their rivals.

There are too many winners in too many divisions to list here — see [www.leukemicup.org/sf](http://www.leukemicup.org/sf) for the full results — but the biggest winners are those who fight blood cancers, both patients and doctors, and that is a very good reason to go sailing.

— dave wilhite

## our breakfast with commodore

It was our privilege, in the middle of October, to enjoy a Captain's Breakfast prepared and served by none other than lifetime sailor Warwick 'Commodore' Tompkins at his Mill Valley aerie. When we say 'lifetime sailor', we're not talking about a mere five or six decades on the ocean. It was in 1932 in Boston that the infant Commodore was brought aboard the family's 105-ft LOA schooner *Wanderbird*, which was built in the 1880s and had long served as the engineless pilot vessel for Germany's Elbe River. Commodore is still going strong — by time you read this, he and his wife Nancy will have flown back to their Wylie 38+ *Flashgirl* in New Zealand's Bay of Islands to start yet another season of cruising.

By the time Commodore — it's been his nickname since he was a baby, not a position he's held or would have wanted to hold — was four years old, he'd sailed across the Atlantic 13 times. Indeed, there are photos of him as a very young boy blithely straddling the bowsprit with his legs alone while the great schooner is underway. The family made a living by operating the schooner as a school ship for the sons and daughters of the East Coast elite.

The Tompkins family eventually sailed around Cape Horn in the winter of '36-'37, making the historic film *Fifty South to Fifty South* in the process. After that they sailed north and settled in Sausalito. Commodore has subsequently done every type of sailing gig one can imagine, from deliveries to Olympic campaigns to driving maxis to running charter boats to building his own Wylie 38+. He also was mentor to a whole generation of Northern California sailors who left their mark in racing circles from California to Florida to England.

Despite more than 80 years and countless hundreds of thousands of sea miles, the no-longer-quite-so-truculent Commodore still doesn't possess a Coast Guard captain's license. Given his views of the real-world qualifications — or lack thereof — of 90% of those who do have such licenses, it's a point of honor that he doesn't have one. It's a view shared by Robert Flowerman, his friend and another of Northern California's most experienced and respected delivery skippers.

After completing *Flashgirl* in Sonoma in April 2000, Commodore and Nancy started their long-distance cruising with a 3,700-mile passage from San Diego to Papeete in '05. They made landfall after just 21 days. Nancy remembers it as "a fabulous passage, one I wished hadn't ended so soon."

The couple have been spending parts of every year since cruising

continued on outside column of next sightings page



Commodore had no fear on his family's schooner 'Wanderbird'.

COURTESY COMMODORE TOMPKINS

# SIGHTINGS

## commodore — cont'd

around various parts of the South Pacific. For example, between December '10 and December '11, they did a 5,500-mile loop of the tropics between Australia and the Bay of Islands, getting as far north as the Caroline Islands. They visited 34 islands and five countries in the process. "The only place that spooked me was New Guinea," says Nancy. "It's dangerous. Everywhere else — particularly the less-

populated areas — is totally safe and the people are very friendly."

Commodore's attraction to the less-visited and less-developed islands of the South Pacific may have something to do with the fact that his father, sick of farming in the Troy, New York-area, kicked around the South Pacific a bit in the '20s. He eventually became the captain of a schooner that travelled up the Fly River in Papua New Guinea to find workers for the sugar cane fields



**Commodore and Nancy agree that Opunohu Bay in Moorea is the most beautiful anchorage in the world.**

of Queensland, Australia. In less-polite terms, it's called blackbirding, hiring black men to work for white people. If you think New Guinea is primitive now — and it is — you should see the now-faded photos his father took. The outfits — or lack thereof — worn by his native first mate Wagi are beyond anything that Hollywood costume departments could produce.

Two months ago, Commodore, who suffered a heart attack decades ago, received a fourth stent. Two days after being released from the hospital, the 80-year-old was aloft the 65-ft Wylie-designed cat ketch schooner *Derick M Baylis* to make sure the rigging was up to his exacting standards. Commodore was to be the supercargo — i.e. owner's rep — on the vessel during a monthlong oceanic research trip off the coasts of Northern California and Oregon for Oregon State University. Having completed that gig, and with the temperatures dropping in foggy, woody Mill Valley, Commodore was eager to get back to his boat.

"I figure I have five or maybe six more years of cruising left in me," Commodore told us, "but Nancy and I haven't figured out where we want to go. We might go east in the tropics, or we might go west. I do know that I want to return to Pohnpei in the Carolines, for I have something of an adopted son there I would like to check up on. And at some point I would love to see British Columbia from the decks of my own yacht. I also want to see the great animals of Africa, but I probably won't sail there."

In Commodore's estimation, there is no more beautiful anchorage in the world than Opunohu Bay, Moorea. Nancy is in agreement. Alas, Moorea is in French Polynesia, which is at the top of Commodore's list of the most expensive places to cruise. By French Polynesia, he includes everything French in the South Pacific, including New Caledonia. Next is Australia, which is much more expensive than the still very expensive Vanuatu and New Zealand. If Commodore wants cheap cruising, he's going to have to return to the remote parts of the Solomon Islands or the Carolines, or maybe give the Philippines or Southeast Asia a try.

For the record, Commodore's Captain's Breakfast consists of soft scrambled eggs, potatoes, onions, strawberries, English muffins, coffee and juice. Delicious.

— richard

## the rocketeer

Film and television actor Billy Campbell, perhaps best known for playing the title role in the '91 film *The Rocketeer*, is officially a hero for helping to save the lives of three sailors earlier this month. On September 10, Campbell and his crew were on the maiden voyage of his new 50-ft David Westergard-designed wooden schooner *Martha Seabury*, which had been launched in Lunenburg, Nova Scotia, in August. They were bound for



**Wagi, first mate on one of the senior Tompkins boats.**



## to the rescue

the Newport Boat Show and were about four miles off Cuttyhunk Island in Massachusetts when, around 7:30 p.m., a crewmember spotted three men clinging to an overturned 15-ft sailing dinghy. Skipper Michael Moreland doused sail, started the engine, and went to their aid.

"The three victims were in their 20s," he said in a report. "Two were in PFDs

*continued in middle column of next sightings page*

## the true *spirit of the sea*

"Captain, can this boat go faster?" shouts an ebullient teenager from Redwood High School's continuation program. A few of his classmates chime in. "Faster! Faster!"

The captain ignores the pleas for speed. Suddenly, as if on cue, the wind picks up and the boat starts to heel as the sails fill with a brisk San Francisco Bay breeze. As the vessel scoots along past Alcatraz, the kids' excitement increases.

On this crystal-clear autumn day, 20 students are under the watchful eye of Capt. Richard Gillette and his all-volunteer crew aboard a 64-ft steel cutter, built more for long-range expedition voyaging than

*continued on outside column of next sightings page*



**"To understand me, you have to understand my father," says Commodore, seen here in his dad's arms.**

SPREAD: LATITUDE / RICHARD. INSETS: COURTESY COMMODORE TOMPKINS

# SIGHTINGS

## *spirit of the sea* — cont'd

sublime daysails. In fact, she recently completed a 13-month, 24,000-mile circumnavigation of the American continents to raise awareness of ocean health issues under the command of Capt. Mark Schrader as *Ocean Watch*.

Capt. Richard's passion for ocean education seems to segue perfectly into this vessel's current incarnation as *Spirit of the Sea*. One year ago, Richard founded the nonprofit organization of the same name, and brings hands-on experiences that are not possible in a classroom.

"Safety is our number one priority," he says. "We strive to be the safest boat on the Bay." The secondary mission is fun. Capt. Richard clearly loves having young people onboard and makes connections easily, whether by teasing a young lady for texting — much to the delight of her peers — or by guiding a youngster who is at the helm.

The ability to capture the attention of a group of teenagers is a much

continued on outside column of next sightings page

## rocketeer

but one was not. It was quickly apparent that all three were hypothermic and low on strength and energy."

After the crew pulled the three men, who were apparently out for a daysail, from the water, they wrapped them in wool and sleeping bags. They were later transferred to a Coast Guard cutter and are reportedly no worse for wear.

As for the schooner, she was conceived as a collaboration between Lunenburg master shipwrights. According to their site, the New Lunenburg Schooners — *Martha* and her 'twin sister' — were "built in the tried and true, time-tested



SPREAD: MARY LOU WAKEFIELD; INSET: JAK MANG

## — cont'd

way with stout wooden planks on heavy double-sawn frames, the same techniques that created the famous 'Fast and Able' North Atlantic fishing schooners *Bluenose* and *Bluenose II* of Lunenburg and the great schooners of Gloucester, but using only the very best materials and finest durable timbers sourced from around the world."

For his part, Campbell says he's thrilled with *Martha's* performance. "She's a dream . . . better than I ever imagined or hoped for." Read more about the 'classic' boats at [twinschooners.blogspot.com](http://twinschooners.blogspot.com).

— ladonna



Spread, British septuagenarian Jeanne Socrates left Victoria, BC, on October 22 on her third nonstop solo circumnavigation attempt aboard her Najad 380 'Nereida'.

*spirit of the sea* — cont'd

more challenging task than sailing this rugged 44-ton vessel. Yet Capt. Richard makes it look easy.

During his environmental awareness lectures, the entire group listens with rapt attention. Of course, bribery helps keep them on their toes: He offers a cherished spot on the bow to the first student who can repeat a fact about ocean conservation.

"What percent of the earth's surface is ocean?" booms the captain's voice. A gaggle of hands fly up. He points to the first one. "Seventy percent, Captain!" responds a young woman, who's attired in Ugg boots, jeans and a 49ers sweatshirt under her life vest.

Richard's passion rubs off as he gently persuades the kids to recycle and do their part for the planet. Many of them have never been on the Bay, let alone on a boat. One 17-year-old boy asks what bridge we're passing under — the Oakland Bay Bridge. What seems natural to us sailors is a whole new world for landlocked youth.

After a delightful three-hour sail, we motor down the Estuary to *Spirit of the Sea's* permanent dock at Jack London Square. London would be proud of the work Richard and his crew do as a pure labor of love; inspiring, cajoling and teaching youngsters about the beauty and fragility of the seas.

Capt. Richard's resume includes 30 years as a professional photographer with his work appearing in *Time*, *Wine Spectator* and many other publications. He was recently recipient of the Jefferson Award for his work with children in the San Francisco Bay Area, and holds a US Coast Guard 100-ton Master's license, and US Sailing Instructor Certificate.

The *Spirit of the Sea* works with many local agencies, and hosts youngsters with life-threatening illnesses, underprivileged youth, foster children and kids from after-school programs. Studying marine organisms, such as viewing plankton through a microscope, adds to the nature of fun scientific and aquatic education.

Once the school group has departed, Richard expresses his immense appreciation to his crew. He exclaims more than once, "We wouldn't be here if it weren't for all of you volunteering your time." One of the women crewing said she was as rusty at sailing as she was at interacting with teenagers, but her motivation for volunteering was to push herself out of her comfort zone.

If you'd like to push your own comfort zone a bit and give back to the community, you can donate time or money by getting in touch with Capt. Richard at [CaptainRichard@spiritofthesea.org](mailto:CaptainRichard@spiritofthesea.org). Find out more at [www.spiritofthesea.org](http://www.spiritofthesea.org).

— lynn ringseis

## the irrepressible jeanne socrates

You just can't keep Jeanne Socrates down. The irrepressible Brit left Victoria, B.C. the morning of October 22 aboard her Najad 380 *Nereida* on her third attempt at a nonstop solo circumnavigation. If she succeeds in completing this one nonstop — she was forced to stop during her last two circumnavigations when her boat was damaged — she'll not only be the oldest woman, at 70, to have done so, she'll also be the only woman to have done so starting from North America.

Though record-keeping organizations no longer recognize age-based sailing records, they are very interested in geographical and gender-based records. That being the case, Canadian Tony Gooch, who set

continued on outside column of next sightings page



Capt. Richard spends his days teaching landlocked youngsters about the ocean.

LYNN RINGSEIS

## socrates — cont'd

the record for the first North American (Victoria) singlehanded nonstop circumnavigation in '03, was on hand to seal her prop shaft and take her time for the World Sailing Speed Record Council. It's interesting to note that Socrates is not sponsored — other than a few equipment donations — and she's sailing to raise money for the Marie Curie Cancer Care, a nonprofit that supplies nurses to terminally ill patients.

Socrates' journey should take about eight months — over half of it in the Southern Ocean! — and we'll be posting frequent updates from her in *Lectronic*. You can also follow her at [www.svneraida.com](http://www.svneraida.com).

— ladonna

## supporting hope for the warriors

Working in the charitable nonprofit sector can be challenging. Getting a new wounded-veteran's sailing program off the ground has entailed a year's worth of 3 a.m. emails and hard work. So it was with much gratitude to learn that Ted Turner would be sailing to benefit our group, Hope for the Warriors, in the recent 12-Meter North American Championship regatta, held off Newport, Rhode Island, in late September. And I was stoked to be invited as a guest of honor and guest speaker next to Turner and Gary Jobson!

Arriving in Newport on a Thursday, I went straight to the yacht harbor and hopped on Ted's old 12-Meter *American Eagle*, which was sporting a big Hope for the Warriors boom cover for the regatta. Sailing on the big, heavy 68-ft yacht was an absolute thrill. After a year of mostly solo ocean racing on a lightweight Moore 24, it was a huge departure to be part of a 16-man crew practicing things like mark roundings, gybe sets and windward douses.

After a great afternoon of sailing in 12 knots of breeze, we docked *American Eagle* back at the wharf and everyone prepared to head to the official regatta dinner, which was again a benefit for Hope for the Warriors. It was an incredible honor to be one of three guest speakers for the evening, in addition to Turner and Jobson. One of the real thrills was just in sharing a dinner with them. They were so gracious and down to earth.

After a night of hanging with the boys in Newport, I cancelled my flight back to Seattle and stayed for an extra three days to sail in the regatta. It was a good decision. With 10-15 knots of breeze for the majority of the regatta, the racing was close and tactical. Traveling back to the West Coast, I prepared to host another wounded-veteran sailing clinic, owing much to the generosity that we received in Newport.

From October 3-6, Hope for the Warriors and BAADS teamed up to conduct our second wounded-vet sailing clinic of the year in San Francisco. The clinic taking place at Pier 40, we flew four wounded Iraq and Afghanistan veterans to the West Coast, in addition to hosting one Marine who was semi-local. Over three days, we taught the guys how to sail using BAADS' Access dinghies in and around McCovey Cove, next to AT&T Park. The guys loved it!

After the sailing on the first day, we took the group to explore Muir Woods. After sailing on the second day, we enjoyed a tour of the Pier 30/32 America's Cup compound courtesy of Team Oracle USA. That night, Drew Harper of Spinnaker Sailing generously took

continued on outside column of next sightings page

## sailgating at

In late August, Discover Boating released their list of favorite 'boatgating' — we, of course, prefer to call it 'sailgating' — locations in the country. "The combination of two American pastimes — boating and tailgating — is still one of the most unique ways to enjoy game day at stadiums across the country," said the press release.

Naturally, San Francisco's AT&T Park, home of the Giants, made the cut. "Catch all the action or even a splash hit — home runs that land in the water on the fly without hitting the Arcade or Portwalk — from

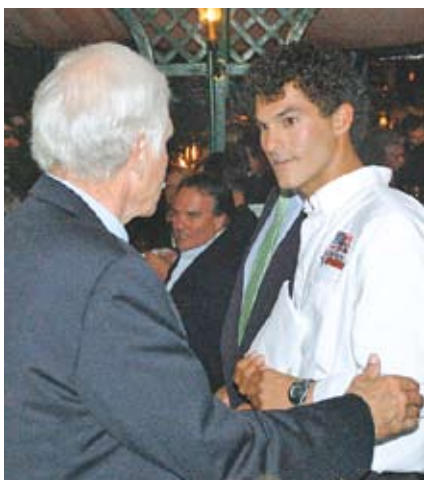

SALLYANNE SANTOS

Ronnie Simpson met sailor, media mogul and philanthropist Ted Turner at the 12-Meter NAs.



## the world series

a boat in McCovey Cove, where the scoreboard and replay screens are visible.”

As baseball fans know, the Giants won the National League Championship Series last month and, as this issue goes to press, are just starting the World Series against the Detroit Tigers. By the time you read this, the popcorn and trash will have been swept away, but we have no doubt the memory of a family cruise-out to McCovey Cove to watch the World Series will not be soon forgotten.

— *ladonna*

## hope — cont'd

the group on a sunset cruise on his Santa Cruz 50 *Yukon Jack* to watch the America's Cup World Series fleet racing. Then on the third day, Team Oracle USA again brought out the red carpet to host our group to a tour of Pier 80 and the AC 72 *USA 17*. The whole thing was epic! One of our veterans, a recent double above-the-knee amputee, was so inspired by the clinic that his new dream is to race sailboats. We're proud and honored to be able to sponsor him in an upcoming Paralympic development regatta.

Hope for the Warriors will be expanding the vet's sailing program to include four clinics for next year, including San Francisco and Newport, Rhode Island. Find out how you can help by emailing me at [rsimpson48@yahoo.com](mailto:rsimpson48@yahoo.com).

— *ronnie simpson*



*Spread, Ted Turner's 12-Meter 'American Eagle' sported the Hope for the Warriors logo during the recent North American Championships for the class. Inset, Simpson has run two sailing clinics for wounded vets with the help of the Bay Area Association of Disabled Sailors (BAADS) and hopes to expand the program. Check out the group's inspirational video at [vimeo.com/50964197](http://vimeo.com/50964197).*

# AC WORLD SERIES, ROUND II —



SPREAD: GILLES MARIN-FRAGET  
INSET: GUILAIN GRENIER

*With the Bay's John Kosteki calling tactics, Spithill's Oracle Team USA was unstoppable.*



# WET, WILD & WONDERFUL



AGEA/GILLES MARTIN-RAGET

Last month's edition of the America's Cup World Series in San Francisco was truly spectacular, despite the fact that a wide range of music and sports events threatened to upstage it. With a massive three-day music fest in Golden Gate Park, Giants playoff games at the AT&T Park, a Niners game at Candlestick and several cultural celebrations downtown, it was said to have been the busiest weekend in the City's history.

But none of that deterred diehard racing fans from turning out to soak in the thrills of the AC45 traveling road show October 3-7.

On-the-water action began on Wednesday, October 3 with match race qualifiers in typical fall conditions: Wind climbed into the low 20s, fog lingered overhead, and the Bay's notorious ebb flowed swiftly. Together this provided challenging racing for the 11-

*With AC45s on the water and F-18s overhead, the ACWS weekend was sensational.*



# AC WORLD SERIES, ROUND II —

boat international fleet.

Notably, 21-year-old Peter Burling of New Zealand, who had taken the helm for Team Korea a mere two weeks prior, won his qualifier over Chris Draper and crew aboard Luna Rossa Piranha. The other youngster and relative newbie in the fleet, 25-year-old Kiwi Phil Robertson aboard the Team China cat, won his first ACWS victory against Luna Rossa Piranha. China Team sustained damage to their wing during a gybe, however, and could not make their third race.

Robertson recalled, "We were about

five minutes before our start and put in a gybe, and the carbon structure in the wing fell apart on us. It almost snapped in half up the middle."

In what was probably a first in international yacht racing, the race schedule on the remaining days of the ACWS was sandwiched around the aerial acrobatics of the Fleet Week Air Show right overhead (practice Thursday and Friday, with the real deal Saturday and Sunday). Thursday's quarterfinals began at noon, with fleet racing after 5

p.m. Wind was tickling the mid-teens at its max velocity in the afternoon, and the ebb didn't fire up until late in the day. For us photographers, shooting in the late afternoon light of the "golden hour" was a real treat.

In the first fleet race Ben Ainslie, skipper of JP Morgan BAR, was sailing his own race, way out ahead. A champion dinghy sailor with five Olympic medals in two classes, he'd finally figured out how to make the big cat go fast after a lackluster showing in the August

PITCHPOLES JEREMY LEONARD / SURFCITYRACING.ORG



SANDER VAN DER BORCH



AGEA / GILLES MARTIN-RAGET





# WET, WILD & WONDERFUL

ACWS races. BAR finished 17 seconds — a big margin in this field — ahead of the second place contender, Oracle Team USA's Spithill.

Friday October 5 saw a huge increase in spectators. The jetty out to the Wave Organ east of the Golden Gate YC was packed. Again there were quarterfinal match races in the morning and fleet races in the afternoon. In the two-boat matchups, Oracle Team USA Spithill beat BAR, while another young skipper, Aussie Nathan Outteridge, 26, helming

Artemis Racing Red, beat the old master, Russell Coutts aboard the second Oracle boat. Another Olympic medalist, Outteridge joined the Artemis Team barely a month prior to this ACWS, having previously raced for Team Korea. Despite a penalty against him at the start of his face-off with Coutts, he won after Coutts rounded the wrong mark.

In Friday's fleet racing Ben Ainslie Racing cleaned up with a first and a second place, while Terry Hutchinson, aboard Artemis Racing White, took

a second and a first. Aboard Artemis Racing Red, Outteridge and crew took the third position overall with a pair of fourth place finishes.

During one of their best races ever, China Team unfortunately lost their jib halyard mid-race. But they flaked the sail on the bowsprit and continued sailing, staying mid-pack for the duration of the race despite having just their main.

Saturday, October 6, was a big day for crowd numbers. The breeze was in the upper teens, the sun was out, the



ELLEN HOKE

*Watching this sort of action up close, it's perfectly clear why these sailors wear crash helmets. Spithill's now-famous pitchpole (above) was the ultimate OMG moment.*



ACEA / GILLES MARTIN-RAGET



ACEA / GILLES MARTIN-RAGET



CHRIS CAMERON



SANDER VAN DER BORCH



ACEA / GILLES MARTIN-RAGET

# AC WORLD SERIES, ROUND II

scene was festive, and San Francisco showed its epic autumn beauty. The entire shoreline was packed in every direction. The spectator fleet was thicker, and more aggressive; it was game on! And the schedule was packed: match race quarterfinals after the air show, then two fleet races followed by the match racing finals.

From my position off the yacht club spit, I was in the perfect position to snag some good bow spray shots as the AC45s bore away around mark 1. As I fired the shutter, I focused on Spithill, who seemed to be pitching a little more radically on this rounding. I kept firing and his bows kept diving down the mineshaft! As Spithill was pitch-poling, I saw Terry Hutchinson expertly maneuver around the whole disaster. For a few seconds, the fleet was stacked in tightly doing 20 knots, and I thought there would surely be a collision. But in a testament to the high degree of skill on the course that day, everyone made it out relatively unscathed. Emirates Team New Zealand finished with a first in Race 6. Ben Ainslie continued sailing



ELLEN HOKE

**For many race fans, the chance to meet superstars like Jimmy Spithill, Loïck Peyron and Ben Ainslie was an unforgettable highlight.**

extremely well with a first in Race 7.

Amazingly enough, after hoisting a crewmember to the masthead to assess several broken ribs in the wing, Spithill came back to win a second place in Fleet Race 2. Even more amazingly, later in the day during the start of his match race with Emirates Team New Zealand's Dean Barker, he luffed ETNZ up so badly during the prestart maneuvers that ETNZ had to tack to avoid a penalty.

Spithill went on to win the match by almost 20 seconds. He'd come back from his capsize with a vengeance, and his team took the match racing title.

Sunday October 7 was another mix of Fleet Week activities followed the Super Sunday Fleet Racing Finals, where scoring was heavily weighted compared to previous races. The wind was in the upper teens and the ebb was flowing. I would have had a hard time believing it if I hadn't seen it with my own eyes, but Spithill climbed the ladder from absolute last place to win that race by 17 seconds. It was unbelievable to watch Oracle Team USA Spithill pick off one competitor at a time. Their incredible comeback left Spithill tied for first in the series with Ainslie, each with 79 points. Spithill was awarded top honors, however, having won the final race.

This edition of the ACWS was so brilliantly orchestrated and thrilling to watch that it will be a hard act to follow — even by the main event, America's Cup 34 in July. We can hardly wait to see that!

— jeremy leonard



**Congratulations  
BRACK DUKER  
SC70 Holua  
Winner  
Campbell Cup**

**Congratulations  
DAN MORRIS  
Easom Rigger  
Winner  
Argo Gold Cup**

## ONE STOP

**Design → Installation → Support!**

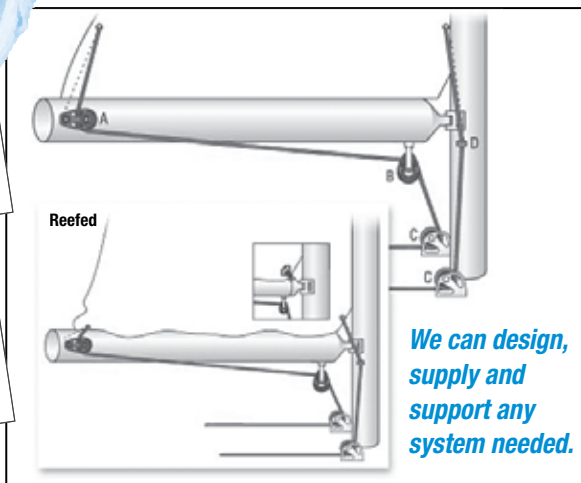

**Easom Racing allows you a complete performance upgrade with one call!**

- Deck layout and design
- Hardware choices
- Installation
- Sail purchase

**CALL FOR A COST-EFFECTIVE ESTIMATE ON YOUR PROJECT.**

**Better Results at Better Prices!**



**Easom Racing and Rigging**

1230 Brickyard Cove Rd., Suite 102  
Point Richmond, CA 94801

**(510) 232-SAIL (7245)**

**[www.easomrigging.com](http://www.easomrigging.com)**



Serving the Bay Area  
Since 1986

**Service of the Month**

**INTERIOR CLEANING**

Keep your boat dry and mildew-free with our interior cleaning service. Remember to run a dehumidifier – with the cold temperatures, the boat's interior will stay moist for weeks!

**ADDITIONAL SERVICES**

Wash Down • Detailing • Maintenance  
Polishing • Carpet & Cushion Cleaning

Fully Insured & Marina Approved  
Call now for a Free Estimate

**510 428-2522 or 415 457-6300**  
**www.seashine.net**

**OFFSHORE**

Racing or Cruising  
Offshore?

Buy, rent or service  
your liferaft at Sal's!



**INSHORE**

Cruising the Delta or  
the coast of Mexico?

A quality, hypalon  
tender is the way to go!



**SAL'S**  
INFLATABLE  
SERVICES, INC.

SALES • SERVICE  
RENTAL • REPAIR

PHONE (510) 522-1824  
FAX (510) 522-1064  
1914 Stanford St., Alameda 94501  
salsinflatables@sbcglobal.net  
www.salsinflatablestableservices.com

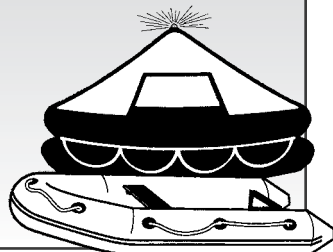

**SVENDSEN'S MARINE**

**Laser Sails**

North Folded Full Sail  
Including Sail Numbers, shipping to your  
location, and all taxes.



PACKAGE PRICE:  
\$565.00

Svensden's Marine Is Your  
Authorized LaserPerformance Dealer

Call for specials  
on other Laser  
Sails!



**Manager's Special**

**NISSAN  
MARINE**

Outboard  
Motors



6hp **SAIL  
PRO**



5hp

3.5hp

Call for  
pricing

1851 Clement Ave.,  
Alameda Marina



Phone:  
**510.521.8454**

Open 7  
days/week

**SVENDSEN'S  
MARINE**

Low Prices –  
Best Selection

[www.svensdensmarine.com](http://www.svensdensmarine.com)

# ENERGY TEAM

We can't remember the last time we got as much reader feedback as we did following our October 10 *'Lectronic Latitude* report that long-time San Francisco Bay anchor-out, musician and — almost paradoxically — St. Francis YC member Todd Tholke had filed suit against Energy Team, the French entry in the America's Cup World Series. Tholke is demanding compensation for his 'salvage' of Energy Team's 45-ft catamaran.

To recap, Tholke's attorney John Edgcomb says Tholke spotted the Energy Team cat on the rocks at Treasure Island in the wee hours of September 30. Tholke then got his 14-ft Boston Whaler skiff and by his lonesome towed the high-performance cat over to Clipper Cove. It's unclear how the cat got loose from her mile-distant mooring at San Francisco's Pier 30-32 in the first place, but the French reportedly thanked Tholke and offered him a ride on their cat in appreciation.

Tholke, through his court filing, has told the French that he thinks \$200,000+ would be a more appreciated expression of gratitude.

We're not experts on maritime law, but those who are tell us it's almost certain that Tholke does have a valid claim for what's called 'harbor salvage'. In fact, so do you if you've ever pulled a boat off the hard, given a boat with a bad engine a tow back to her berth, loaned an out-of-fuel mariner gas, or in one of countless other ways assisted a fellow mariner.

Many readers have written *Latitude* to say they believe that assisting other mariners is a point of honor among sailors, and that they never would have dreamed of asking anything for what Tholke did. "I can't help but make a comparison to the recent rescue of Derk Wolmuth's Vindo 40 *Bela Bartok*, which had to be abandoned because of a medical emergency during the Singlehanded TransPac," writes Ben Johnston. "The generosity of time and resources on the part of other Singlehanded TransPac participants, with no thought of compensation, was truly an inspiring story that gave me a positive feeling about mankind."

At first glance, one has to wonder how difficult Tholke's Energy Team salvage was. After all, it was done by one person, in the middle of the night, in just a couple of hours, with nothing more than a 14-ft skiff. But in a court filing made after the final World Series race in October, Tholke claims he's owed a high reward because he put himself and his boat at considerable risk. For example, it's mentioned that his 70-hp outboard

smoked and that his skiff nearly capsized several times on what has been described as a calm night. "The 45 was in no immediate danger, and Tholke risked causing serious damage to it by doing the rescue himself," wrote Eric Anderson in disagreeing with Tholke's assertion.

In a story in the *San Francisco Chronicle*, Tholke's lawyer makes the claim that his client didn't rescue the Energy Team for the money, but rather because he wanted "to be a hero." Yet as many respondents to *Latitude* pointed out, if Tholke wasn't doing it for the money, why is he asking for \$200,000? "Ever notice that whenever people say that it's not about the money, it often is about the money?" asks a skeptical Adrian Morgan.

Others thought that Tholke didn't act heroically at all. "I think he deserves a prize for stupidity, nothing more," wrote Thomas Gradie. "I wouldn't have tried to salvage a 45-ft cat with a 14-ft skiff in the middle of the night by myself."

Why, many readers wondered, didn't Tholke simply let the Coast Guard, which had contact numbers for the America's Cup organizers and the French team, handle the situation with professional equipment? After all, it doesn't appear there was a great emergency in retrieving the light but robustly built cat.

The size of Tholke's claim, as well as the fact that he spotted Energy Team on the rocks in the early hours of the morning, caused many readers to wonder if Tholke hadn't had a hand in the cat's getting loose in the first place. "Sometimes the firefighter is the arsonist," notes Walter E. Smithe III.

We think these are emotional rather than rational responses. After all, Tholke is a long-time musician, and many musicians come home late at night after gigs. Our gut feeling is that Tholke has a bunch of people who could vouch for his whereabouts when the cat got loose.

Of the 118 responses — at last count — that we received, only a few backed Tholke's claim. "Considering the cost of replacement of the cat, it seems the demand for \$200K may be legitimate," wrote Michael Caplan. "Calm conditions or not, anytime a salvage effort is initiated, there is a potential of adverse consequences to the party involved in the effort."

Horst Lechler, on the other hand, thought \$200,000 might be the least expensive way out for the French. "While \$200,000 sounds like a lot of money, it's probably a smaller amount than if they



fight it and have to pay attorney fees, expert witness fees, taxes, and so forth, So I am for the \$200,000."

But several other respondents put themselves at the other end of the opinion spectrum.

"How about a hearty 'thank you' from the French, and if that wasn't enough, a kick in the ass," wrote James Jennett. "You do this type of thing to help another person, not to claim salvage. Welcome to California and the United States."

"I'd give Tholke a swift kick in the ass," writes Matthew Krohn. "I would have called Vessel Assist."

"Shoot the SOB," suggests Steve Gann, explaining that "Tholke gives sailors and good seamen a bad reputation."

The following is a sample of the other responses we received, edited for brevity and in a few cases clarity. We think this is a reasonably good sample of the total we received.

"I'd award Tholke a new skiff and engine. But had I been in his shoes, I'd have told the French, 'Happy to have been of help. I hope you have the opportunity to do the same for some other mariner in the future. But come on brothers, we're all in this together.'" —Marty Goldsmith

# ON THE ROCKS



ACEY / GILLES MARTIN-RAGET

"I feel like Tholke missed a tremendous opportunity to be a hero. Lending assistance to other vessels is a fundamental rule of the sea, and it's a shame when it gets turned around for profit." —*Chuck Hawley*

"I would have done the salvage for nothing, and enjoyed the ride as offered because that's how I choose to live. Unfortunately, we live in a society where doing the right thing is rarely done without a motive. I don't live hand to mouth — doing things for free is easy for me — so I think Tholke deserves compensation per the law, but not \$200,000." —*Bill Lockridge*

"I pulled plenty of boats off after Hurricane Ike here in Texas, and didn't ask for money. I know Tholke needs money, but he should wait until someone offers, then accept." —*Capt. Fred Lowe*

"I would have given him a post-regatta ride on the cat, and a Corum men's Admiral's Cup Swiss watch from the team sponsor." —*Kent Arndt*

"I think just a free ride was not a very generous offer, and thus an unappreciated gesture. On the other hand, given Tholke's life circumstances — he's not exactly rolling in dough — I feel a \$5-10,000 expression of appreciation would not be unreasonable. But I would have tried to save the cat in a New York minute

without thinking about a reward. Sailors help other sailors, plain and simple." —*Bill Rehm*

"Wow! How embarrassing for the community of San Francisco street artists, and what a sad commentary on our local anchor-outs. Tholke had a chance to be a hero, but he and Edgcomb have gone down the slimy weasel opportunist path instead." —*Mark Wieber*

"The contradictions in this story are legion, from 'Todd wasn't doing it for the money' to Tholke's claim in the *Bay Guardian* to stand 'for freedom and liberty,' a stand somewhat undermined by having the Energy Team cat arrested." —*August Zajonc*

"I would have pulled the cat off the shoreline and back to the marina, then accepted a beer, handshake, ride, or gas money as thanks. We sailors take care of each other with no thought of repayment — other than the expectation that others would do the same for us." —*John Griffith*

"If you're going to be an underhanded opportunist, then at least have the balls to admit it. But for God's sake, don't go crying Mother Teresa on us. Even if Tholke's skiff was damaged, why would he need anything other than the replacement cost of it?" —*Marianne Armand*

"If Tholke gets \$200,000 for 'find-

ing' a lost boat, what should I give my neighbor who found me semi-conscious on the ground after I recently fell from the roof? A million dollars? But perhaps a little more generosity on the part of the French might have forestalled the claim." —*Max Nankervis, Australia*

"I don't know maritime law, but good citizenship and seamanship would suggest Tholke should have allowed Energy Team a chance to rescue the cat before he did. If his dinghy drifted onto the beach at night, would a person collecting it have a claim, even if it was easily retrievable and in no danger of sinking?" —*Bryan Chavez*

"Whatever happened to doing something nice for someone just because it's the right thing to do?" —*Marlane Angle*

"Tholke is a disgrace to all sailors, San Francisco, the United States, and the world. Sailors don't treat other sailors this way." —*Rodney Kidd*

"What a shitty attitude. Everyone deserves what they get." —*Tony Dibnah*

"What an embarrassment to San Francisco's sailing community. This is how we treat guests? I am disgusted with this guy's behavior." —*Nick Gibbens*

"If I were Tholke, I'd find the nearest rock and crawl under it." —*Helen Horn (owner of six boats)*

"Tholke will eventually need help from his fellow sailors, and he won't wish for the treatment he is according our French guests." —*Jim Stevens*

"Just do the right thing, people. Take care of each other. Be civil and respectful, and it will come back to you. But I guess we'll never get there if we don't kill all the lawyers first." —*Brian Richards*

"I would not settle for anything less than two rides! But that's because I'm a greedy motherfucker! But if Tholke did save their boat from additional damage at some cost to himself, and it was their carelessness that was to blame, I'd say maybe \$10,000." —*Marc Bodian*

"Even Vessel Assist only charges \$300 an hour for a tow. Tholke is going to be short on karma. By the way, is his boat one of those non-permitted ones that still anchors out in Clipper Cove?" —*Dave Biron*

"I understand the French team have offered \$25,000, which should be very adequate, with a ride or two, for Tholke's effort." —*Charles Cunningham*

"I would have asked for a ride with one or two of my sailing buds. My girlfriend would have rescued the boat for nothing more than dinner with Loïck Peyron. I've towed people out of harm's way without a second thought. A real sailor wouldn't do this." —*Nick Salvador*

# ENERGY TEAM

"The Ugly American that Tholke portrays by demanding \$200K when he 'wasn't doing it for the money' is most unfortunate. What have we come to when we can't just help someone out for the sake of being a good member of the community?" —*Jeannie Crum, New Zealand*

"Something will happen to us all, and we'll need to rely on someone else. Fortunately, most of us know that. Pay it forward, folks, don't milk it." —*Tim Litvin*

"I think Tholke did a good thing, and deserves a lot more than a free ride. Perhaps a dinghy swap, a new outboard for his Whaler, or one of their Protectors." —*Jim Gossman*

"My opinion is that towing an AC45 with an outboard-powered 14-ft Whaler is risky at best, especially singlehanded. If anything had gone wrong, Tholke could have drifted into the path of a ship. Maybe it's more like piracy than salvage." —*Vernon Huffer*

Perhaps the most original answer came from Wayne Meretsky, who lost his S&S 47 *Moonduster* to a tropical cyclone

in Fiji a few years back:

"Energy Team should just give Tholke the cat and be done with it. After all, the AC45 is now worthless at best and actually a massive liability. The World Series is nearly finished, and the boats will never be used again. So let Tholke have to deal with disposing of it and the several containers of now mostly worthless associated equipment. Tholke will get his just deserts without even knowing it. As for the French, walking away saves them legal fees and salvage cost, plus the cost of shipping the cat back to Europe. Furthermore, it gets them out of the World Series, which is a dead-end for them anyway. It's the perfect conclusion to a silly story."

What would we at *Latitude* have done had we been in Tholke's Top-Siders? We'd have contacted the Coast Guard to contact the French team, knowing they had the right people and equipment for

the job. But we would have hung around to watch and lend a hand if needed, just for the pure fun of it. If we were a judge who had to rule on the salvage claim, we would award Tholke the same amount that Vessel Assist or a similar tow service would have billed the French. We would not give Tholke anything for any damage to his outboard or his Whaler, because there was no emergency, so it was he who chose to attempt a rescue without adequate equipment and manpower.

In closing, we wonder if anybody else is struck by the seeming incongruity between awards for saving boats as opposed to awards for saving people. Say somebody does a relatively hard and dangerous rescue of a \$1 million vessel in adverse conditions. It's not uncommon for such salvors to be awarded between \$100,000 and \$250,000. Using that as a yardstick, what is someone entitled to for saving the life of someone who has fallen overboard or is drowning? Yet we can't remember courts ever awarding somebody money for saving the life of someone else. Curious, don't you think?

— *latitude/richard*

**INSURING YACHTS FOR OVER 50 YEARS**

Providing Cruisers and Racers All Over the World with Prompt, Reliable Service since 1959

**MARINERS**  
GENERAL INSURANCE GROUP

Contact Us for a Quote

**Exclusive MARINERS *Odyssey*® Program**  
Mexico  
South America  
South Pacific  
Caribbean  
Mediterranean

**Racing Sailboat Program**  
TransPac  
Pacific Cup  
PV / Cabo Races  
Caribbean Regattas

[www.marinersins.com](http://www.marinersins.com)

**QUALITY COVERAGE AVAILABLE IN MEXICO**  
Mariners Insurance Mexico offers insurance programs for health, homes, autos, motorcycles and yachts in Mexico.  
[www.marinersmexico.com](http://www.marinersmexico.com)

Corporate Office: 206 Riverside Ave., Suite A, Newport Beach, CA 92663 / Ins. Lic. #0D36887

Seattle 800-823-2798

N. California boomeins@aol.com 800-853-6504

L.A./Orange Co. 800-992-4443

San Diego 800-639-0002

Puerto Vallarta 52-322-297-6440

East Coast Bradenton, FL 800-914-9928

**HOME TO  
EMERYVILLE  
SPORTS  
FISHING**

# Emeryville Marina

**ON THE BAY**

**NEW SLIPS!**

*Now taking reservations  
for 40' to 60'*

*When you call Emeryville Marina Home...  
...call this your backyard!*

**Free Wi-Fi  
and Video  
Surveillance**

**Slips from 20-65 ft  
Full Amenities - including  
Fuel Dock & Pumpout Station**

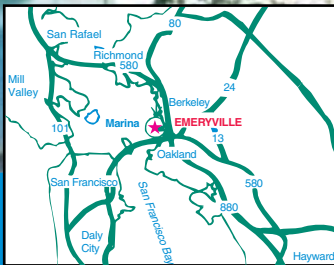

**MARINAS<sup>™</sup>**  
International

**(510) 654-3716**

[www.emeryvillemarina.com](http://www.emeryvillemarina.com)



## Start Line Strategies

**Winning Legal Planning  
for Sport Programs**

*10 years America's Cup Experience*

Sponsor & Venue Arrangements • Crew Contracts  
Vessel Shipping Logistics • Charter Agreements

**Ashley Tobin**

(925) 324-3686 • [amtobin2@gmail.com](mailto:amtobin2@gmail.com)

[www.pacificmaritimelaw.com](http://www.pacificmaritimelaw.com)

## Maritime Law Offices of Jared A. Washkowitz

SF Bay Area | So. Cal. | Hawai'i

Vessel Documentation  
Fed. & State Regulation  
Charter Parties  
Personal Injuries  
Wrongful Death  
Maritime Liens  
Vessel Arrests  
Limitation of Liability  
Towage

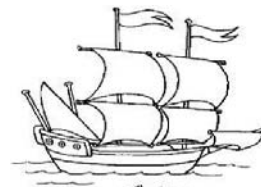

Collision/Allision  
Vessel Financing  
Cargo Loss & Damage  
Longshore Act  
Jones Act  
Wreck Removal  
Salvage  
Marine Insurance  
+ other practice areas

Email: [jaw@pacificmaritimelaw.com](mailto:jaw@pacificmaritimelaw.com)

PH: +1 (415) 320-8254 (Calif.) | +1 (808) 840-7410 (Haw.)

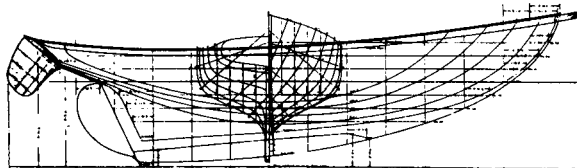

## MAKELA BOATWORKS

*Family owned since 1948*

**Wooden Boat Building • Repair and Restoration**

19280 South Harbor Drive • Fort Bragg, CA 95437

**(707) 964-3963**

email: [howard@makelaboatworks.com](mailto:howard@makelaboatworks.com) • [www.Makelaboatworks.com](http://www.Makelaboatworks.com)



### SLIDING PIVOT SUPPORTS

Solar panel rail mounts,  
pivoting, adjustable slides.



### TEAK SEAT

Collapsible, fits straight rail  
or in corner,  
swing-down support leg.



### COCKPIT TABLE MOUNTING HARDWARE KIT

Lightweight, anodized  
aluminum, adjustable,  
collapsible, easily removable.  
Extra base plate to use the  
table in both cockpit and  
salon. Tabletop available in  
StarBoard, teak or make  
your own. Solar mounting  
hardware available, too.

**HOTWIRE ENTERPRISES**  
[www.svhotwire.com](http://www.svhotwire.com)

Phone/Fax 727-943-0424  
email: [hotwiregam@aol.com](mailto:hotwiregam@aol.com)



# JESSICA CUP —

**S**kipper Bill Belmont was naturally pleased to win the Farrallon Clipper class in last month's Jessica Cup (October 13), but to him the race will be especially memorable because he got to sail his 1952 woodie *Credit* alongside the classic beauty *Dorade*, which now graces San Francisco Bay once again.

"It was exciting to see her out racing as she's one of America's most famous sailboats," Belmont commented. "And, of course, (the 1935 56-ft S&S schooner) *Santana* was out — another of America's most famous sailboats — as well as (the 1937 8-Meter) *Yucca*, which is a West Coast favorite, and probably the winning-est boat on the Bay. It was just spectacular."

Built in 1929, the 52-ft yawl *Dorade*



ALL PHOTOS LATITUDE / ANDY

was one of the first designs to come out of the then-fledgling design firm Sparkman and Stephens, and is considered by many experts to be the most influential sailing yacht ever built. San Franciscans Matt Brooks and Pam Levy purchased her in August 2010 and immediately put her into a full refit in Newport, RI, with the intention of preparing her for ocean racing again. Their goal was to repeat all of her early ocean races: Newport-Bermuda (done this June), Transpacific 2013, Newport-Bermuda 2014 (again), Transatlantic 2015, Fastnet, and Cowes. During her heyday, decades ago, *Dorade* won all of these races, a record that stands unbeaten today says Levy.

She's the first classic yacht the couple has owned. Two and a half years ago



**Spread:** Having returned to the Bay after a very long hiatus, *'Dorade'* (foreground) was looking sweet as she chased *'Yucca'* around the course. **Inset left:** Jennifer Hinkel helms her beautiful Farrallon Clipper *'Ouessant'*. **Inset right:** A wave from happy rail-riders aboard the L-36 *'Leda'*.



# BEAUTIES ON THE BAY



# JESSICA CUP —

they were looking for a boat to daysail together on the Bay and, as Levy describes it, "ended up with a historic boat that needed a full refit 3,000 miles away, and that takes 8+ people to race."

After spending a year and a half going back and forth to Newport overseeing the refit while working full time in San Francisco, they finally got to spend the winter racing her in the Caribbean, winning her class in every regatta she entered, as well as the Concours d'Elegance in the Antigua Classic Yacht Regatta.

"We both work in fields completely

unrelated to sailing, and we're both middle-aged with grown children," explained Levy, "so this has been quite an unexpected adventure."

*Dorade* and crew were late sign-ups for the Jessica Cup, but no less enthusiastic. Local crew members included Danielle Dignan who helmed, Melinda Erkelens, Bob Hanelt (owner of the classic yacht *Skylark*, another S&S design),

and Mark Adams. *Dorade* took second in the Marconi 1 class, losing to Hank Easom's *Yucca* (which won the Jessica Cup). *Dorade's* new owners put in a fine effort considering it's been years — perhaps 30 — since Brooks and Levy have raced on the Bay. Paul and Chrissy Kaplan's *Santana* took third in class.

"What's interesting for us is that the general feel here is a little more infor-

**Clockwise from upper left: 'Leda' shows her winning form; Belmont's 'Credit' was sailing sweetly; The FC 'VIP' works toward Blackaller; 'Sequestor' holds off 'Brigadoon' in light air; the splendid 'Dorade' works up the Cityfront with Danielle Dignan at the helm.**



# BEAUTIES ON THE BAY

mal," Levy commented. "In Newport, even the older classics are driven with great resolve to win, and it's more competitive, I think, especially in the classics. One of our interests in refitting and bringing her to the West Coast is that we think these boats can be raced hard. When we race, no matter what kind of race it is, we race to win! I think that's still our mission," Levy laughed. "Hopefully that will inspire other people to do the same, right?"

One owner/skipper who needs little inspiration to race hard is Easom, who in his usual low-key style took home yet another win in class. He's won every time he's sailed the Jessica Cup, which he *thinks* is eight times.

Easom described his race, "After a delayed start, a beautiful westerly came in. We didn't know how the heck we'd do with *Dorade*. We had a good start. She tried a port-tack start, which I thought might work, but actually it didn't. We were overlapped with *Santana* at the start, but sailed out underneath her, tacked, then led at every mark... I guess we were faster, which is a nice thing to

have happen!"

Paul Kaplan can appreciate what it means to have *Dorade* on the Bay, "It really is a special sight to have both *Santana* and *Dorade* sailing together. The

*"We had 'em the whole damn race until that last leg."*

boats are similar designs from the same designer, just a few years different in age, and the hull shapes and aesthetics of the boats are not too different from each other. Matt and Pam have done a spectacular job with the boat. Matt has been very methodical in following the original design as much as he could during the refit — the mast is a brand-new wooden spar with internal halyards no less — a beautiful job."

There was no breeze to speak of at the scheduled noon gun. But about an

hour and a half later the breeze built up enough to allow one of the two anticipated races to be run.

In the Marconi 2 division, David James' lovely Lapworth 36 took top honors, followed by Bill Clausson's *Bird Curlew* and Allen Edwards' L-36 *Papoose*.

Among the gaffers, Ken Inouye's 34-ft gaff ketch *Makhani Kai* took first, followed by Hans List's Tahiti ketch *Sequestor* and Terry Klaus' gaff schooner *Brigadoon*. List was disappointed with second place after sailing a great race until the last leg, where he and his crew suffered two spinnaker-related foul-ups.

"I really did want to beat *Makhani Kai*, not only because Ken Inouye is a good friend, but also because my mother-in-law (Suzanne Statler) was on that boat!" List laughed. "We had 'em the whole damn race until that last leg."

Well, Hans, there's always next year. Perhaps then you may want to think about having Suzanne race on *your* boat! (See [www.mastermariners.org](http://www.mastermariners.org) for complete results.)

— michelle slade

## RARE OPPORTUNITY!

### Two 40-ft Covered Slips & a 62-ft Slip Available

# LOCH LOMOND MARINA

**Completely Rebuilt Marina • Gas & Diesel Fuel Dock • Free Pump Out Station  
Modern Launch Ramp • Guest Slips Available • Marine Mechanical Boat Repair  
Arena Marine Supply Store • Andy's Local Market • Bait Shop  
Land or Sea Canvas • Windjammer Yacht Sales • Loch Lomond Yacht Club**

**110 Loch Lomond Drive, San Rafael, CA 94901**

**Phone: (415) 454-7228 • Fax: (415) 454-6154**

**[www.lochlomondmarina.com](http://www.lochlomondmarina.com)**

**Harbor Master – Pat Lopez • [pat@lochlomondmarina.com](mailto:pat@lochlomondmarina.com)**

# BAJA HA-HA PROFILES, PT III —

As you read this the 147-boat Baja Ha-Ha fleet is scudding south toward new adventures and sunnier latitudes. If you're a regular reader you know that this 19th incarnation of the San Diego-to-Cabo San Lucas rally has been dubbed the 'Don't Stop Believin' Ha-Ha, commemorating the years — and in some cases, decades — that many fleet members have spent preparing for, and dreaming about, sampling the cruising lifestyle south of the border. The fleet is expected to round the southern tip of Baja California and enter Cabo Harbor on Thursday, November 8.

Picking up where we left off last month, we'll introduce you to the final entrants in this year's two-week rally. As you probably noted in the previous two installments of fleet profiles, this disparate armada of cruising boats is crewed by sailors from all walks of life. (They are listed here in the order in which they signed up.

**Mona Too — Hunter Legend 45**  
**David Halaby, Berkeley**

*Occupation:* cabinet biz owner (retired)

*Crew:* son Lex Halaby

*Quote:* "I planned to keep working as long as I could get to the shop. Luckily the economy tanked so I get to do the Ha-Ha while I am still young and healthy."

*Cruise Plans:* Spend winter on the Mexican mainland or head for Panama and the Caribbean.

**Aleutian Light — Cal 31**  
**Nick Hindman, Alameda**

*Occupation:* fisheries biologist (ret)

*Crew:* TBD

*Quote:* "I'm excited and optimistic!"

*Cruise Plans:* South to Costa Rica

**Osprey — Gulfstar 50**  
**Kirk Miller, Sausalito**

*Occupation:* charter boat captain

*Crew:* daughter Miya, 14, Andy Signal, Dick & Dan Fancher, Kurt Wear

*Quote:* "I'm looking forward to not having a schedule!"

*Cruise Plans:* Cruise a while, then bash home.

**Wallflower — Kalik 44**  
**Deron Bardin, San Diego**

*Occupation:* golf management

*Crew:* father Larry & Karin Phares

*Quote:* "Let's go!"

*Cruise Plans:* A season of cruising, then bash home.

**Scuttle Butt — Formosa 41**  
**Bruce Glass, Two Harbors**

*Occupation:* Catalina Harbor Dept. (ret)

*Crew:* Ralph Davidson

*Quote:* Bruce is looking for a boatmate: "Seaworthy woman wanted, must love to cook, clean and varnish."

*Cruise Plans:* Open-ended: "The boat is home!"

*"The best time to go to Mexico is when you can!"*

**Heart2Heart — Irwin 41**  
**Jeff Overley, Avalon**

*Occupation:* plumbing contractor (ret)

*Crew:* Carroll Goss & Rory Kremer

*Noteworthy:* Jeff lives aboard traveling the California coast, and visits Mexico each year.

*Cruise Plans:* South to El Salvador; sail home in a couple of years.

**Sea Angel — Catalina 42**  
**Brian Taugher, Sacramento**

*Occupation:* attorney (ret)

*Crew:* Joe Bettaker, Wayne Matzen & Daniel Dunkel

*Quote:* "The best time to go to Mexico is when you can!"

*Cruise Plans:* Mainland Mexico.

**Bonnie Lass — Catalina Morgan 440**  
**Bill Alexander, Tiburon**

*Occupation:* renewable energy executive (ret)

*Crew:* Eric Bishop

*Quote:* "This will be our second Ha-Ha. The first was a blast.

*Cruise Plans:* Continue south.

**Scintilla — CT 49**  
**Chris Harry & Chris Barnes**  
**Seattle, WA**

*The 'Scintilla' crew have flexible plans.*



*Occupations:* engineer; teacher (both ret)

*Quote:* "We have done many Seattle-to-Portland bicycle rides with literally 10,000 other riders. If we liked that event, we will love the Ha-Ha."

*Cruise Plans:* "Continue south, then maybe west. . . or maybe east."

**Aurora — Hylas 46**  
**Curtis Johnson &**

**Katie Osgood-Johnson, Reno, NV**

*Occupations:* fire chief (ret); private school manager

*Crew:* Karen Junker & William Hoelscher

*Quote:* "What a great way to escape from the great state of California."

*Cruise Plans:* Cruise until spring, then bash home for the America's Cup.

**Tusitala — Townsend 47**  
**Briana Moseley & David Adolphs**  
**San Francisco**

*Occupations:* mediator; CPA

*Quote:* "Life's hard, sailing's easy, tack on the headers, stay on the lifts, and have fun!"

*Cruise Plans:* On to the Galapagos, then possibly to French Polynesia.

**Flying Fox — Corsair 31**  
**George Woodley, Incline Village, NV**

*Occupation:* engineering exec (ret)

*Crew:* Reini Westphal

*Quote:* "My crew and I met in '99 on our first Ha-Ha. It's a wonderful venue to meet lifelong friends with similar interests."

*Cruise Plans:* Sail the mainland this winter, then on the hard for summer.

**Talion — Gulfstar 50**  
**Patsy Verhoeven, La Paz, BCS**

*Occupation:* real estate (ret)

*Crew:* Jon & Sue Drake

*Quote:* "This will be my 6th year of sailing all the way."

*Cruise Plans:* Home to La Paz.

**Emerald Isle — Island Packet 420**  
**Mike & Kathee Mealer, Goodyear, AZ**

*Occupations:* aerospace engineer; civil engineer (both ret)

*Crew:* John McMillan

*Quote:* "We have no plans and, by God, we are sticking to them."

*Cruise Plans:* Explore the mainland, then north to Ensenada.

**Red — Waterline 38**  
**Richard Dowling & Fran Kelly**  
**Juneau, AK**



# DON'T STOP BELIEVIN'



*The 'Thunderbird' crew are not just going cruising, they're on a mission.*

**Occupations:** executive; development director (both ret)

**Quote:** "We're heading south until the butter melts!"

**Cruise Plans:** First step of a South Pacific cruise.

**Silhouette — Beneteau 423  
Phil Donatto, San Antonio, TX**

**Occupation:** engineer (ret)

**Crew:** brother Aaron

**Quote:** "We'll have to wait and see — could be fun."

**Cruise Plans:** Begin a circumnavigation at Cabo.

**Beach Access — Lagoon 380  
Glenn Twichell, Newport Beach**

**Occupation:** electrician

*The 'Beach Access' crew will be back again.*



**Crew:** Debbie Jahn, Paul Ludgate, Monte Cottrell & Trish Goforth

**Quote:** "It's great to have so many of my cruising friends in one place. For me the Ha-Ha is a floating reunion."

**Cruise Plans:** No plans to bring the boat north again.

**Inspire — Bavaria 47  
Arvid & Annika Elias  
Seattle, WA**

**Occupations:** both program managers

**Noteworthy:** This is a German boat with Swedish rigging, sailed from Seattle by a Swedish couple and their Canadian Great Dane (dog) named Pluto.

**Cruise Plans:** A season in Mexico.

**Sojourn — Pearson Alberg 35  
Bridget & Bruce Eastman, Brisbane**

**Occupations:** college counselor; nurse practitioner (both ret)

**Crew:** Dave Kendall

**Quote:** "We wanted to do the Ha-Ha twice before, but life intervened. Let's hope the third time is the charm."

**Cruise Plans:** Sea of Cortez, then south to Puerto Vallarta.



*The third time's the charm for 'Sojourn'.*

**En Pointe — Searunner 31  
Tom Van Dyke, San Francisco**

**Occupation:** journalist

**Crew:** TBA

**Quote:** "Each day my gratitude exceeds my expectations, then I have a good day." — Ray Wylie Hubbard

**Cruise Plans:** No plans to return.

**Mariah — Gulf 32 PH  
Ken Painter, Seattle, WA**

**Occupation:** physical therapist

**Crew:** Andy Cole & Leah Blaschke  
**Quote:** "Feel the fear but do it anyhow! After sailing from Seattle to San Diego, including the *Delta Doo Dah*, this summer I'm not quite so scared though."

**Cruise Plans:** Cruise Baja, then bash to San Diego and truck to Seattle.



*The international 'Inspire' crew.*

**Mean Kitty — Catalina 42  
William Walters, Ventura**

**Occupation:** MD

**Crew:** Kay Fain, Chuck Landis, Lori Beraha & Alan (Doc) Roske

**Noteworthy:** In his younger days William did some serious offshore sailing, including Hong Kong to Iwo Jima and Seattle to Kodiak, AK.

**Cruise Plans:** Bash in late November.

**Got D'Fever — DeFever 45 PH  
Leonard & Lorena Landon  
Kirkland, WA**

**Occupations:** tech business owner; author (both ret)

**Quote:** "After years of cruising the Pacific Northwest including Canada and Alaska, we're southbound to see the color of turquoise, experience the warm water, and witness that bright ball in the sky."

**Cruise Plans:** "Enjoy the culture of Mexico and then continue southward and eastward."

**Aphrodite — Jeanneau SO 45  
Peggy & Barry Corlett, Brisbane**

**Occupations:** engineering designer; holistic health counselor

**Crew:** daughter Genna, 13, & Robert Tinus

**Noteworthy:** "The most interesting thing about our entry in the Ha-Ha is that we're actually doing it!"

**Cruise Plans:** Undetermined.

**Ronin — Caliber 38  
Dwayne Jennings, Vancouver, BC**

**Occupation:** helicopter pilot

**Crew:** Stephen ('the Hammer') Cox

**Noteworthy:** Every past and present owner of this boat has taken her to the

# BAJA HA-HA PROFILES, PT III —

Sea of Cortez.

*Cruise Plans:* Farther south; eventually do the Pacific Puddle Jump.

**Trumpeter — Newport Gulf 32**  
**Bob & Robby Hinds**  
**Chula Vista**

*Occupations:* both lawyers

*Crew:* Steve Labarre

*Noteworthy:* Bob and Robby are father and son

*Cruise Plans:* A month or more at Cabo or Mazatlan.

**Dos Tacos — Seawind 1160 cat**  
**Tony & Michelle Soter, Portland, OR**  
*Occupations:* wine-makers  
*Crew:* daughter Livi, 14, son Anton, 12, & Mark DeMaria

*Noteworthy:* "We will barely finish the harvest and fermentation of the new wines before putting them into barrels and shoving off for Mexico."

*Cruise Plans:* Boat stays in Mexico.

**Bluewater — Seawind 1000 cat**  
**Mark Barrish & Lawrence Kerver**  
**Santa Cruz**

*Occupations:* patent attorney; engineer



Meet Mark of 'Bluewater'.

*Cruise Plans:* Sea of Cortez.

**Camelot — Hunter 54**  
**Howie & Donna Shaw, Portland, OR**  
*Occupations:* traffic engineer; secretary (both retired)

*Crew:* son Craig Shaw, daughter Sandi, Jane Roy & Kenneth Smith

*Noteworthy:* At 84, Howie may be the fleet's elder statesman; he crewed on a previous rally for Craig.

*Cruise Plans:* A season in Mexico.

**Kinda Blue — Hershine 41**  
**Jerome Phillips, Portland, OR**  
*Occupation:* musician

*Crew:* Ron Capasso & Don Mertie

*Noteworthy:* There's a piano on board!

*Cruise Plans:* Winter in Mexico.

**Brizo — Coronado 35**  
**Tom & Leila Whitney Miron**  
**Portland, OR**

*Occupations:* sailing club manager; student (both in their 20s, but "retired")

*Crew:* Kristine DeWilde

*Noteworthy:* All on board are under 30, and former college sailors.

*Cruise Plans:* "Onward south!"

**Ripple Effect — Creekmore 35**  
**Jay Ahrens, San Francisco**

*Occupation:* web developer

*Crew:* Kau Bahler & Tiffanie Linkin

*Quote:* "This is an excellent way to be-

"After three years of blood, sweat and beers we're ready to go!"

gin a foreign cruising lifestyle. It has the safety of numbers, and a concentration of sailors to develop a personal cruising network."

*Cruise Plans:* Bash back in January.

**Patricia Belle — 66-ft schooner**  
**Patrick & Geni Hughes, Seattle, WA**  
*Occupations:* merchant marine; nurse (both ret)

*Crew:* TBA

*Quote:* "Can't we all just get along?"

*Noteworthy:* They built this steel vessel themselves.

*Cruise Plans:* South, then on to Hawaii and San Diego.

**Star Passage — Valiant 40**  
**Peter & Kim Johnson, Pt. Richmond**

*Occupations:* CEO; mom

*Crew:* son Harlan, 11, & daughter Sophie, 8

*Quote:* "Let the music begin!"

*Cruise Plans:* Stay in Mexico.

**Scout — Jeanneau SO 52.2**  
**Greg Himes, Whitefish, MT**

*Occupation:* educator

*Crew:* Liz Wilson & Liz Lococo

*Quote:* "If life gives you the west coast of Baja, make it into the Baja Ha-Ha.

*Cruise Plans:* Bash to LA in June.

**Palapa — Cal 34**  
**Aron & Rheanne Kormout**  
**Moss Landing**

*Occupations:* wildland firefighter; waitress

*Crew:* TBA

*Quote:* "After three years of blood, sweat and beers (refitting this stock '69 classic), we're ready to go!"

*Cruise Plans:* Cruise the mainland and the Sea of Cortez, then commuter cruise.

**Blackjack — Hunter 46.6**  
**Jonathan Peebles, Point Loma**

*Occupation:* sales

*Crew:* Bill Kirk

*Quote:* "This boat was spoiled as a baby; now it wants to kick ass."

*Cruise Plans:* This is a shakedown for a cruise to Australia.

**Sisu — Hans Christian 43**  
**Christopher & Barbara Warnock**  
**San Francisco**

*Occupations:* CEO (ret); graphic designer

*Crew:* sons John, 17, & Joshua ('Yoshi'), 15

*Noteworthy:* This rare '78 cutter-rigged ketch survived a category-five hurricane in Tonga in '85, skippered by Phil Howe.

*Cruise Plans:* Undecided.

**Purusha — Spencer 53**  
**Erin Hope-Goldsmith & Lyndie Burt**  
**Vancouver, BC**

*Occupation:* Lyndie, kinesiologist

*Crew:* David Caves (capt.), Anna Cunningham, Anniken Chadwick, Naomi ('Pony') Peterson & Shireen Nabatian

*Noteworthy:* The *Purusha* crew call themselves fun-loving hippies who love making music. Aboard are guitars, flute, sax, violin and piano!

*Cruise Plans:* Continue south.

**Sweet Dreams — Irwin 54**  
**Jim & Gina Nie**  
**Portland, OR**

*Occupations:* both managers (ret)

*Crew:* son Colton, 14, & daughter Niki, 11

*Noteworthy:* We're sure Jim and Gina will make lots of friends — they have an icemaker on board.

*Cruise Plans:* A season in Mexico, then perhaps a trip to Papua New Guinea to do missionary work.

**Truant — Cabo Rico 38**  
**Frank Murphy, San Diego**

*Occupation:* real estate

*Crew:* G.W. Grigg, & Chip Scire

*Quote:* "Hoping the adventure is even better than all the stories in the pages

# DON'T STOP BELIEVIN'



*The 'Patricia Belle' was built by her owners.*

of *Latitude 38* that I've been living vicariously through all these years."

*Cruise Plans:* Continue cruising Mexico.

**Golden Eagle — Catalina 30  
Ethan Johnson, Seattle, WA**

*Occupation:* ski maker

*Crew:* Jennea Thornburg

*Quote:* "Let the naysayers step aside so the doers can get through."

*Cruise Plans:* "Wing it!"

**Fellowship — Valiant 42  
Rich & Lyn Lewis  
Wilmington, DE**

*Occupations:* special ed. administrator; school social worker (both ret)

*Quote:* "Life is not about the destination. It's about the journey and the reason for it."

*Cruise Plans:* On to Loreto to work with Mexican Medical Missions. Then Puddle Jump to the So Pac to do more of the same.

**Thunderbird 1 — Albin Stratus 36  
International Rescue Group, Alameda**

*Crew:* Jack "The Professor" Li, Jenni Hecker & Evelyne Dumas

*Noteworthy:* This is the first boat in International Rescue Group's anticipated fleet. Her mission is to provide humanitarian aid to disaster-hit, mainly Third World coastal communities.

*Cruise Plans:* Boat will operate between Mexico and Panama.

**Joya — Dreadnought 32  
Steve Pruitt, Brookings, OR**

*Occupation:* chandlery owner

*Crew:* son Dylan, 24

*Noteworthy:* *Joya* has a beautiful

mermaid painted on her bow.

*Cruise Plans:* Enjoy Mexico before bashing home.

**Blackheart —  
Coronado 30  
Darcy McBride &  
Traci Grant  
Del Mar Marina**  
*Occupations:* plumber; firefighter  
*Crew:* Phillip Tate  
*Quote:* "We're excited!"

*Cruise Plans:* Bash home.

**Arcane — Aura 40  
Jean Cote & Jacinthe Morin  
Montreal, QC**

*Occupations:* TV producer; financial officer

*Quote:* "We're playful as the dolphins we will meet on the way, patient, and hopefully as wise as the old turtles of the Baja.

*Cruise Plans:* Undecided.

**Cariba — Bayfield 36  
Gab Cote & Isabelle Valois  
Vancouver, BC**

*Occupations:* apparel brand director; teacher

*Quote:* "We're just here for a good time."

*Cruise Plans:* Eventually on to the South Pacific.



*The 'Cariba' crew are looing for good times.*

**She Said OK — Catalina 30  
Jeff Kiddy, San Diego**

*Occupation:* chiropractor (ret)

*Crew:* Mike Kouris

*Noteworthy:* Mike says he heard about the rally on TV — perhaps during coverage of our departure parade one year.

*Cruise Plans:* Onward!

**Lady J — Beneteau 393  
Steve Hirsh, San Diego**

*Occupation:* hay hauler

*Crew:* Mike Sanduskey

*Quote:* Just do it.

*Cruise Plans:* Sail on. . .

**Kairos — Beneteau 50  
Thilo Kuther, Road Town, BVI**  
*Occupation:* designer  
*Crew:* Claudia Weingaertner  
*Noteworthy:* Thilo's sailing resume includes lots of exotic sailing including the Greek Isles, Tahiti and the Eastern Caribbean.  
*Cruise Plans:* Undecided.

**Emerald Lady — Cheoy Lee 47  
John & Kelly Wanamaker, Seattle, WA**  
*Occupations:* real estate (ret)  
*Crew:* Gina Kaler & Karl Bettinger



*The 'Emerald Lady' crew will live their dream.*

*Quote:* "Dream the life; live the Dream. The Ha-Ha is the start of living our dream in a big way."

*Cruise Plans:* Continue cruising indefinitely.

**Distant Drum — Idylle 15.50  
Harry Hazzard, San Diego**

*Occupation:* info tech (ret)

*Crew:* Mark Noyes

*Noteworthy:* Harry started sailing at age 8.

*Cruise Plans:* Mexico, Central America, then Galapagos

**Bella Dama — Islander 36  
Chad Kominek, Ventura**

*Occupation:* business owner

*Crew:* bro Rorke & Marvin Stevens

*Quote:* "My wife died this year. Life is short. Go now!"

*Cruise Plans:* Cruise Mexico, possibly for more than a season.

# BAJA HA-HA PROFILES, PT III

## Someday — Hunter 35.5

**Don McNeil, Channel Island**

Occupation: N/A (ret)

Crew: Leah Wright

Quote: "The wind's in my sails and the sea to my back, to take me down and bring me back!"

Cruise Plans: Cruise the mainland, then the Sea of Cortez.

## Magic — Kelly-Peterson 44

**Terry & Marian Benjamin, San Diego**

Occupations: R&D chemist; editor

Quote: "We're in for the fun!"

Cruise Plans: No plans to go home.

## Sweet Cherri — Columbia 36

**Josh & Julia Siudyla**

Alameda

Occupations: sailor; geologist

Crew: Zack Launiere

Quote: "We are living our dreams!"

Cruise Plans: Cruise indefinitely.

## Corinna — Allied Wright 36

**Christopher & Christine Jette**

San Francisco

Occupations: composer; anesthesiolo-

gist

Noteworthy: They both just finished grad school and are taking a break to cruise.

Cruise Plans: Bash home in December.

## Happy Trails — True North 34

**Ed Trzebiatowski**

San Francisco

Occupation: engineer

Crew: Marc Culver (capt.)

Quote: "I want to go to Mexico! I want a great learning cruise with lots of fun people."

Cruise Plans: Stay in Mexico.

## Moontide — Lagoon 470

**Bill Lilly, Newport Beach**

Occupation: real estate developer

Crew: Judy ('Hootie') Lang, Beverly Smith, Danna Pomykal, Liz Brown, Carol Hefferman

Noteworthy: Somehow Bill was able to put together an all-girl crew — again!

Cruise Plans: May decide it's easier to keep going.



Lots of laughs on 'Moontide'.

## Northern Passage

—Kanter PH 51

**Bruce Rein &**

**Jennifer Gordon**

**Seldovia, AK**

Occupation: fiber optic cable engineer; writer/editor

Crew: son Richard, 12 & daughter Carmen, 10

Quote: "Our cruising plan is to be unplanned, and here we are at the right place at the right time, so

why not join the fun?"

Cruise Plans: Continue south, then into the Caribbean.

**W**hew! That's a lot of cruisers. We wish them all the best of luck and boatloads of fun!

— **latitude/andy**

Look for our complete Baja Ha-Ha rally recap next month.)

## MEXICO CRUISERS STEP ONE:

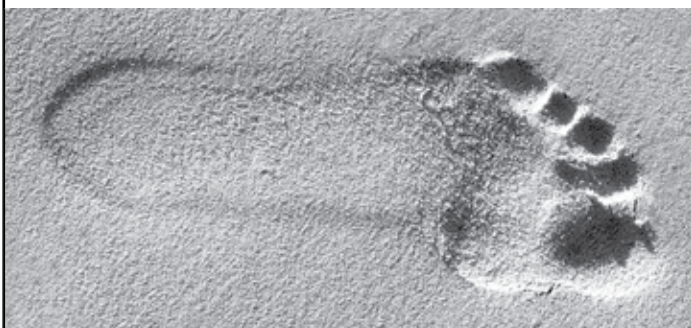

MAKE A RESERVATION AT MARINA EL CID  
FIVE STARS FULL SERVICE MARINA  
**MAZATLAN**

You'll get such a great "impression"  
from our marina services and beaches,  
you may never leave!



**El Cid**  
RESORTS  
mazatlan - cozumel - cancan

[www.elcidmarinas.com](http://www.elcidmarinas.com)

011-52 (669) 916-3468

[marinaelcidmazatlan@elcid.com.mx](mailto:marinaelcidmazatlan@elcid.com.mx)

## Let Hydrovane sail you home safely.

### WHAT IF...

- Autopilot fails
- Batteries are dead
- Engine won't start
- Steering broken
- Rudder is damaged
- Crew incapacitated

### NO WORRIES WITH HYDROVANE

Totally independent  
self-steering system  
and emergency rudder...  
in place and ready to go.



← Larry and Nelda on Diamond Girl, their Beneteau 393, in Paradise Village, MX March 2012

"The Hydrovane exceeded all our expectations!  
In over 600 hours of use it did not loose our  
course a single time!"

- Larry upon arrival  
in the Marquesas



WWW.HYDROVANE.COM



1.604.925.2660  
[info@hydrovane.com](mailto:info@hydrovane.com)

SURVIVE YOUR DREAM



# BAJA HA-HA XIX



BROUGHT TO YOU  
BY THESE  
OFFICIAL SPONSORS

[WWW.BAJA-HAHA.COM](http://WWW.BAJA-HAHA.COM)

The Rally Committee encourages you to patronize the advertisers who make this event possible – and take advantage of their Baja Ha-Ha Specials! (Turn the page for more.)

Your  
Yacht Club  
South of the  
Border



Vallarta Yacht Club

<http://vallartayachtclub.org>  
<http://banderasbayregatta.com>

Everything you need from a full service yacht club.

Home  
of the  
Banderas Bay  
Regatta

## ARE YOU READY TO HA-HA?

One look at the Ha-Ha XIX entry roster at [www.baja-haha.com](http://www.baja-haha.com) shows you that boat types in this year's fleet are as varied as ever, and the crews who sail them will be as colorful as in years past.

In addition to many first-timers, there will undoubtedly be plenty of 'repeat offenders' who want to replay some of the fun and great sailing that they experienced the last time around. Some full-time Mexico cruisers even sail all the way back to San Diego each fall just to re-do the rally.

If you're new to the event, let us explain that the Ha-Ha is a 750-mile cruisers' rally from San Diego to Cabo San Lucas, with stops along the way at Turtle Bay and Bahia Santa Maria.

You'll find frequent updates on this year's event on 'Lectronic Latitude' at [www.latitude38.com](http://www.latitude38.com).

Summer  
is safe at  
Paradise



Paradise Village  
BEACH RESORT & SPA

Enjoy  
your stay  
with us!

011-52-322-226-6728 • [www.paradisevillage.com](http://www.paradisevillage.com)  
marina@paradisevillagegroup.com

Nautical Books, Software, Charts  
and more!



WAYPOINT

621 - 4th St., Oakland, CA

[www.waypoints.com](http://www.waypoints.com) • (510) 769-1547

## RIGGING ONLY

Standing and running rigging, lifelines, furlers, winches, headsail poles, main slider systems, windlasses, travelers, wire terminals, blocks and more...  
Expert advice for selection and installation.

Since  
1984

[www.riggingandhardware.com](http://www.riggingandhardware.com)  
(508) 992-0434 • [sail@riggingonly.com](mailto:sail@riggingonly.com)



Award-winning Marine Communications Equipment

Handhelds • Mounted VHF • SSB • AIS

Visit one of our many West Coast dealers

[www.icomamerica.com/marine](http://www.icomamerica.com/marine)

### SELF-STEERING AND EMERGENCY RUDDERS



SCANMAR  
INTERNATIONAL

Factory  
Direct

432 South 1st Street • Pt. Richmond, CA 94804  
Toll Free: (888) 946-3826 • Tel: (510) 215-2010  
email: [scanmar@selfsteer.com](mailto:scanmar@selfsteer.com) • [www.selfsteer.com](http://www.selfsteer.com)

## West Marine®

Call

1•800•BOATING

(1•800•262-8464)

for a catalog or the store nearest you.



Est. 1973

Almar Marinas

Everywhere you'd like to be  
[almar.com](http://almar.com)

# BAJA HA-HA XIX



[www.downwindmarine.com](http://www.downwindmarine.com)  
2804 Cañon St., San Diego  
(619) 224-2733 • (800) 269-0241



[www.sandiegomarine.com](http://www.sandiegomarine.com)  
2636 Shelter Island Dr., San Diego  
(619) 223-7159 • (800) 336-7369  
Mexico 001-500-336-7369



[www.sailingsupply.com](http://www.sailingsupply.com)  
2822 Cañon Street, San Diego  
(619) 225-9411 • (800) 532-3831

## MEET THE FLEET

In this edition you'll find our final installment of fleet mini-profiles. Previous installments appeared in September and October. (Every edition of *Latitude 38* is available in our downloadable eBook archive at [www.latitude38.com](http://www.latitude38.com).)

As you'll read, the roster of entrants is made up of a highly diverse group, some sailing million-dollar yachts, others on modest 'plastic classics'.

Many crew found rides this year via our free online Crew List at [www.latitude38.com](http://www.latitude38.com), which is constantly updated. Check it out for post-Ha-Ha cruising positions, as well as spots on Bay Area daysails and races.

## PACIFIC PUDDLE JUMP

For many cruisers, the next logical step after cruising Mexican waters for a season or more is to hang a right and head west into the Pacific.

We call that annual springtime migration the **Pacific Puddle Jump**, and we report on it heavily in the pages of *Latitude 38*. Making that 3,000-mile passage is one of the most thrilling accomplishments in the realm of sailing. Learn more about it at [www.pacificpuddlejump.com](http://www.pacificpuddlejump.com).



**Let Marina El Cid  
Welcome You to Mexico**

*A Cruiser's Paradise!*

[www.elcid.com](http://www.elcid.com)

[marinaelcidmazatlan@elcid.com.mx](mailto:marinaelcidmazatlan@elcid.com.mx)  
011-52 (669) 916-3468



**New Mexican  
Liability Program**  
\*Lower Rates \* Tender Included\*  
\*Short Term Policies Available\*  
**(800) 992-4443**

[www.marinersins.com](http://www.marinersins.com)  
*See Our Half-Page Ad In This Issue*

Newport Beach, CA - San Diego, CA  
Burlingame, CA - Seattle, WA  
Sarasota, FL - \*Puerto Vallarta, MX  
\*Affiliate company of Mariner Insurance Mexico

**Best Marina in Banderas Bay**



MARINA RIVIERA NAYARIT

[www.marinarivieranayarit.com](http://www.marinarivieranayarit.com)

011-52-329-295-5526

**BLUE LATITUDE PRESS**

The best cruising information for the *Sea of Cortez* and *Pacific Mainland Mexico*

[WWW.BLUELATITUDEPRESS.COM](http://WWW.BLUELATITUDEPRESS.COM)



**New Sails  
and Sail Repair**

**(619) 226-1133**

[www.UllmanSailsSD.com](http://www.UllmanSailsSD.com)



Sign up here.  
Get QR Reader  
FREE at your  
App Store.

• Ultra Anchors • Ultra Swivels  
• Quickline Flat Rope & Reel • Ultra Trip Hooks  
• Ultra Chain Grabs, Ultra Snubbers & Ultra Bridles

[www.Quickline.us](http://www.Quickline.us)  
[www.UltraAnchors.us](http://www.UltraAnchors.us)  
[sales@Quickline.us](mailto:sales@Quickline.us)  
714-843-6964

*The World's Highest Quality Marine Products*



*Not just a marina – a cruiser's community*  
Your best destination across the Sea...

[www.marina-mazatlan.com](http://www.marina-mazatlan.com)

011-52 (669) 669-2936 & 2937  
[jaimeruiz@marinamazatlan.com](mailto:jaimeruiz@marinamazatlan.com)



Survive Your Dream

**ECHO Tec Watermakers**

604-925-2660 [www.hydrovane.com](http://www.hydrovane.com)



Toll Free from US/Canada  
**866-578-2636**

Mexican Land Line  
**011-52-322-297-2249**

Cell  
**011-52-1-322-182-0006**

[www.vallartayachts.net](http://www.vallartayachts.net)

**INTERNATIONAL HEALTH AND EVACUATION INSURANCE**

**HTH Worldwide**

*Best in cruisers medical insurance  
for the Baja Ha-Ha and beyond*

[WWW.HEALTHISINTERNATIONAL.COM](http://WWW.HEALTHISINTERNATIONAL.COM)



**wichard**  
*Legendary stainless steel forging*

[www.wichard-usa.com](http://www.wichard-usa.com)

**(866) 621-1062**

[info@wichard-usa.com](mailto:info@wichard-usa.com)

# BROUGHT TO YOU BY THESE OFFICIAL SPONSORS



**La Paz Hotel Association**  
Welcomes you to La Paz,  
Enjoy our Baja Ha-Ha  
Beach Fiesta  
November the 20th  
011-52 (612) 122-4624  
www.golapaz.com



**OPEQUIMAR**  
MARINE CENTER CENTRO MARINO

A Full Service Boat Yard in Puerto Vallarta  
88 ton Travelift • Parts • Service • Repairs  
011-52 (322) 221-1800 [www.opequimar.com](http://www.opequimar.com)  
info@opequimar.com



*Weather, Email and  
Voice Solutions.*

Satellite Phone Sales  
and Rentals.

[www.ocens.com](http://www.ocens.com)  
sales@ocens.com • (800) 746-1462

**SAN DIEGO BAY'S**



**HARBOR ISLAND WEST MARINA**  
*Serving Southbound Cruisers in San Diego  
Bay for over 40 years*  
[www.harborislandwestmarina.com](http://www.harborislandwestmarina.com)  
619.291.6440  
**CALL ABOUT OUR BAJA HA-HA CRUISER SPECIAL!**

**CHANNEL ISLANDS MARINA & VINTAGE MARINA**



*For info on our  
exciting slip  
incentives call  
805.984.3366.*

**Mexico Boating  
Guide** Capt. Pat Rains

Covers every mile - no fluff!  
Pacific Baja  
Upper Sea of Cortez  
Lower Sea of Cortez  
Gold Coast  
Costa del Sur *New 3rd Edition  
2012*  
[www.MexicoBoating.com](http://www.MexicoBoating.com)

## IMPORTANT DATES

- Oct. 20** — Ha-Ha Welcome to San Diego Party, Downwind Marine, 12-4 pm. Ha-Ha entrants only.
- Oct. 27** — Pacific Puddle Jump seminar, West Marine, San Diego, 5 pm.
- Oct. 28, 9 am** — Final deadline for all crew and skipper waivers, West Marine, San Diego.
- Oct. 28, 11 am** — Skipper's meeting, West Marine, San Diego. Skippers only please.
- Oct. 28, 1 pm** — Ha-Ha Halloween Costume Party and Barbecue, West Marine, San Diego.
- Oct. 29, 11 am** — S.D. Harbor Parade and Start of Leg 1
- Nov. 3, 8 am** — Start of Leg 2
- Nov. 7, 7 am** — Start of Leg 3
- Nov. 9** — Cabo Beach Party
- Nov. 10** — Awards presentations hosted by the Cabo Marina.
- Nov. 20, 4-7 pm** — La Paz Beach Party. Mexican folk dancing, live music, food & drinks, door prizes, more.

See [www.baja-haha.com](http://www.baja-haha.com) for a list of additional seminars and special events held by our event sponsors.

**Baja Ha-Ha, LLC**  
c/o 15 Locust Ave., Mill Valley, CA 94941  
**WWW.BAJA-HAHA.COM**

**PLEASE NOTE:** Correspondence relating to the event can be emailed to [andy@baja-haha.com](mailto:andy@baja-haha.com). Please don't call *Latitude 38* with questions. The Ha-Ha is a separate operation.



**MARINA DE LA PAZ**  
**FULL SERVICE MARINA**  
Conveniently located downtown  
Tel: 011-52 (612) 122-1646  
Fax: 011-52 (612) 125-5900  
email: [marinalapaz@prodigy.net.mx](mailto:marinalapaz@prodigy.net.mx)  
[www.marinelapaz.com](http://www.marinelapaz.com)



*A Sailor's  
Consignment  
Chandlery*

Located at Grand Marina Dealer for Lavac Marine Toilets  
[www.bluepelicanmarine.com](http://www.bluepelicanmarine.com)  
**(510) 769-4858**

**SAN DIEGO'S RIGGING CENTER**  
Proudly serving for over 25 years



**We'll get you ready for your  
next sailing adventure!**

Design consulting • Commissioning • Refits  
Custom line and hardware

**(619)**  
WE SHIP RIGGING WORLDWIDE  
[www.pacificoffshorerigging.com](http://www.pacificoffshorerigging.com) **226-1252**



Go Cruising, Not Camping, with High Output Water Makers, Alternators, and Power Products.  
[www.cruiseROwater.com](http://www.cruiseROwater.com)



**Charlie's Charts**  
Cruising Guides & More!

Now, the most accurate Navigation Charts of Baja and the Sea of Cortez by Gerry Cunningham have joined the most well known and beloved Cruising Guides of Mexico, the U.S. West Coast and beyond... *Take our combined 70 years of Mexico cruising experience along on your adventure!*

GERRY SINCE 1973  
BAJA & SEA OF CORTAZ NAVIGATION CHARTS  
[www.charliescharts.com](http://www.charliescharts.com)

**FISHERMAN'S LANDING - SAN DIEGO**



Your source for the most extensive line of saltwater fishing tackle, lures, rods and reels available!  
**(800) 566-0273**  
[www.saltwatertackle.com](http://www.saltwatertackle.com)

# MAX EBB

I really didn't expect to find much activity at the university sailing club on a rainy weekday afternoon. But with more rain in the forecast for the weekend, and most of my regular crew suddenly discovering they had prior obligations, this was the most likely place to sign up some last-minute replacements.

Fortunately for my recruiting effort, I found the little unheated equipment and maintenance shed that serves as their clubhouse crowded with enthusiastic young sailors, the smells of hot chocolate and wet wool hanging in the air.

Several college students were gathered around an electric radiator and a chalkboard, and one of them was delivering what appeared to be a lecture on basic sailing theory.

"Always remember to tension the jib luff before going sailing," the instructor advised. "And it's especially important to always remember to slack it off when you put the boat away, or else you'll put a permanent bend in the hull."

"Can we tip the mast forward more by making the jib halyard tighter to reduce weather helm?" asked one of his students.

"No, the mast rake is controlled by the adjustment plates for the shrouds. The jib halyard needs to be very tight for the furling to work properly. Of course you could reduce weather helm by setting the shroud adjusters looser to rake the mast forward, but only the vice commodore in charge of dinghy maintenance should change those settings."

"What's weather helm?" asked a young college student. She was wearing a wetsuit and a soaking wet sweater.

"Remember when we were sailing rudderless during the lesson?" asked the instructor. "The boat kept turning up into the wind every time we sheeted in the main. That's weather helm, and it's caused by the center of pressure of the sails . . ." He paused to draw a profile view of a sailboat, with the geometric center of the mainsail marked. ". . . behind the center of lateral resistance."

He completed the diagram by indicating the center of the side force on the centerboard.

"Force on the sails is here. The equal and opposite force on the centerboard is here. So the result is a turning force that turns the boat into the wind."

"That's why we couldn't go straight until we raised the centerboard most of the way up," observed another student of sailing. "Now I think I see why."

"We can steer by letting the main luff and pulling the jib in. That moves the center of pressure in front of the center

of lateral resistance, and we bear off. Or we can let the jib out and pull the main in. That moves the center of pressure aft, and we head up."

"But we actually did most of our turning by just letting the boat heel more, or by hiking out and making it heel less," said a third student. "Pulling the main in makes the boat heel more, and it seemed to me like that's what was making us turn into the wind."

"Right, good observation," said the instructor. "Heeling has a big effect on helm because the boat's hull becomes asymmetrical. The bow on the leeward side pushes more water away so the boat goes the other way, and that's why it always turns away from the direction of heel."

He pronounced 'leeward' with a long e, so I started to wonder if this kid really knew what he was talking about.

"One boat down," shouted someone from another small group of club members over by the window. "Windy-windy!"

I moved over to the window to take a look. One of the club's sailing dinghies had apparently just performed a spectacular capsize not far from the dock. Another boat sailed past them on a full plane with their asymmetrical spinnaker flying from an extended bowsprit. The windsurfers and kiteboards were going even faster.

"This sure isn't the way we taught sailing when I was in college," I remarked to the people looking out the window with me as a strong gust rattled the window pane. "Rudderless sailing and big spinnakers in high wind were only for the experts. But if anyone would like to check out sailing on a big boat this weekend, I have three, maybe four crew spots to fill for the midwinter race."

The front door to the clubhouse was

*"This sure isn't the way we taught sailing when I was in college."*

flung open and another member, an older man, burst into the room in a cloud of wind-driven spray and rain.

"Windy-windy!" he exclaimed in a thick Japanese accent. I concluded, from his harness hook and helmet, that he must be a windsurfer. Now that the

storm wind was up to full force, the sailing thrill craft were having a really good day. It was as if no one had even heard my crew call. And no one cared much about the capsize, either. It was all routine at this place, from rudderless sailing lessons for beginners to A-sails in 25 knot gusts.

I moved back over to the chalkboard to see if maybe one of those students would be interested in crewing.

"I don't sink zee heeling of zee boat gives it zee weather helm,"

said one of the students who looked like a tall undergraduate with what I took to be a German accent. "On a surfboard, zee turn is in zee same direction as zee lean."

The instructor formed a shape with his hands that looked vaguely like the bow of a boat and explained again how water pressure on the leeward bow caused the boat to turn in the opposite direction. But the surfer was sure it would work the other way. "Zee bottom is much wider zan it is deep, just like zee surfboard," he pointed out. "Zey both have a lot of, how do you say, spoon in zee hull . . ."

"We call it rocker," added another sailor from across the small room.

"Yes, zere is rocker in zee hull. Zee bow should have only a small effect."

The instructor didn't have a good explanation for this, but the student in the wet sweater, who was huddling over the radiator trying to keep warm, did. "I think he's right," she suggested. "It's the transverse shift in the thrust of the sails that causes weather helm to increase when the boat heels, not the forces on the bow."

She went on to propose that it would be easy to perform an experiment involving a boat powered by a small outboard, to separate the turning effect of the hull



# — BRAVING THE WEATHER



*Going sailing is the best way to learn how to do it, but it can be distracting.*

LATITUDE / ROB

forces from the turning effect of the sail forces. This was immediately criticized by another student who claimed it would be invalid because the outboard's propeller, and therefore center of thrust, is too far below the hull and would introduce a turning moment when the boat heeled. Not to mention the angled propeller shaft. Finally they agreed that a valid result could be obtained with the boat coasting, after casting off a towline.

"Back to basic sailing theory," announced the instructor as he directed our attention to the chalkboard. "The opposite of weather helm is when the boat tries to fall off when the tiller is let go. This is called lee helm."

As if on cue, the door opened and in walked Lee Helm herself, letting in another cloud of cold wind-driven rain. "Like, windy-windy!" she exclaimed. "Awesome day."

Then her eyes caught the diagram on the board which said: "Weather helm: Boat heads up with helm free. Lee helm: Boat falls off with helm free."

"Um, that's not really true," she said as she pointed to the chalkboard while shaking sea water out of her hair.

"That's how the books always define it," the instructor insisted.

"The books are, like, wrong," Lee stated flatly. "Two things have a big ef-

fect on how a boat turns when you let go of the tiller, and neither of them has anything to do with actual weather helm or lee helm."

We all turned to Lee to hear what those two things were.

"One is how balanced the rudder is. If the rudder is unbalanced and swept back like on old-style dinghies, or like a Laser rudder half retracted for sculling, you get a lot more force on the tiller for the same amount of lift force on the rudder. That will make the boat seem as if it has a really heavy weather helm, even if it doesn't really have any at all."

"Ah, but it will have more weather helm if you kick up the rudder blade, because the force on the tiller is more," said the instructor.

"That's another, different definition of weather helm that's also totally wrong," Lee asserted. "Some people think that weather helm is the force on the tiller required to steer a straight course. But, like, consider a balanced rudder. There might be no force on the tiller at all if it's perfectly balanced, even at a high angle. And the exact same rudder blade built with the rudder stock at a different angle might be way under-balanced, putting a lot of force on the tiller. But the water sees exactly the same rudder blade at exactly the same angle of attack in both cases."

"Well sure, the design of the rudder af-

fects the helm force without necessarily affecting the angle of the rudder blade. But I think it's still the best definition of helm. And isn't helm force going to be the only thing that determines which way the boat turns when you let go?"

"Not always. Tiller and rudder weight is the other factor that can change the hands-free turn direction. If you put a big hiking stick at the end of a long tiller on a boat with a very light helm force to start with, when you heel the tiller will fall to the low side. It's not such a small effect in light air."

"Okay Lee," I had to ask. "How do you define weather helm?"

"It should always be based on angle, not force," she stated. "If the rudder blade is at the same angle as the keel, that is, parallel to the boat's centerline, then there's no helm. If the rudder has to be angled to a couple of degrees, more angle of attack than the keel, just to keep the boat going straight, then there's weather helm. If the rudder is at a lower angle of attack than the keel, then it's lee helm, even though the angle of attack through the water might still be positive, and there might still be a force on the tiller that feels like weather helm, and the boat might still round up when you let go of the tiller. This is common with an unbalanced or swept-back rudder."

"Zat is how I define it also," added the German sailor.

"I still think the direction of turn after you let go of the tiller is the more useful definition," said the instructor. "It's a safety thing. In a gust, you want the boat to turn into the wind."

"That happened during my lesson last week when someone let go of the tiller in a gust," recalled the woman in the wet sweater. "The boat made a sharp turn into the wind but that just backwinded the jib and forced us to come about, and with everyone suddenly on the low side we flipped right over."

"The actual reason we should care about helm," Lee continued, "is to minimize total drag. Any foil that creates lift also creates drag, pretty much in proportion to the lift squared. The goal is to, like, evenly distribute the lift between the centerboard and the rudder. Not by area, but by span length. So if the rudder is two-thirds as long as the centerboard, then that's five-thirds total, and two-fifths of the lift should come from the rudder and the other three-fifths of the lift should come from the centerboard or keel."

"That almost makes sense," I said.

Lee caught some confused faces in the group, and explained that by "lift"

# MAX EBB

she didn't mean upward force, but side force resisting leeway.

"Since the rudder usually has a smaller chord length than the keel or centerboard, it usually has to operate at a higher angle of attack to get the same lift span loading as the keel."

There were more confused faces.

"We want the same amount of lift per foot of foil length for the keel as for the rudder. It usually works out to a couple of degrees more angle on the rudder compared to the keel, so the optimum weather helm is usually just a couple of degrees positive, measuring from the boat's centerline."

"You forget about zee downwash angle from zee keel," said the German sailor.

"For sure. But that's hard to measure, and it's a pretty small angle anyway. It might add another, like, half-degree to the optimum weather helm angle."

I surmised from the expression on the instructor's face that he didn't really follow the logic, and that he really didn't like giving up his old definition of helm balance.

"You can't fire a volunteer," Lee whis-

pered to me. But before the debate could heat up any more we were interrupted by another soaking wet sailor bursting into the room amid another cloud of cold wind-driven rain and spray.

"Two boats over," he shouted. "I think one of them is going to need some assistance to keep them off the rocks."

The person behind the desk gave an annoyed sigh as he put down his textbook, put on a foulie jacket and a PFD, then took a VHF out of the charging cradle and clipped it to a ring on the lifejacket. Another big gust of wind shook the building and rattled the window panes.

"Windy-windy-windy," shouted the Japanese windsurfer gleefully.

"It's totally gusting over 30," Lee announced as she read the anemometer on the clubhouse wall.

With that, she and her windsurfing friends tightened up their harness straps and started for the door.

"Wait!" I called after them. "The reason I came down here today was to sign up

crew for the big boat race this weekend. I need a foredeck, a tactician and a couple of good grinders."

"Does it include lunch?" Lee asked.

"Of course!" I replied quickly, knowing how much a free meal can motivate a starving student. "Custom orders from the fancy sandwich shop uptown."

"Hmm," Lee considered. "But if the wind is up I'd much rather be windsurfing."

"And a nice dinner if we win our division," I added, gesturing toward the upscale waterfront restaurant down the shoreline a ways.

"I'll sign zee articles," said the German sailor, "but only if zee wind is less zan force seven. I cannot crew if vee have gale varnings for I will be vindsurfing."

"I'll sign up under those terms, too," said Lee, and two of her friends immediately followed suit for a total of four new recruits.

**M**y crew was all set. As long as the wind didn't blow.

— max ebb

## THE MARINE GRADE MOLD & ODOR ELIMINATOR

### "My Cabin Smells Great!"

"I have a 43 footer with an odor that no amount of cleaning would eliminate. We placed Tea Tree Power Gel in the cabin and now the whole boat has a fresh scent. I'm a believer." - Greg C. South Wharf Yacht Yard

After only three days, my locker smells fresh and the mold that was present wipes clean very easily. Good stuff." - Rob M. Basin Marine

### Marine Grade Odor Control

All Natural Made With 100% Australian Tea Tree Oil  
Degrades & Attacks Mold, Mildew, And Bacteria  
Neutralizes & Eliminates Odors Safely & Naturally  
Long Lasting-Protection Maintains Healthy Cabin Air



# FORESPAR®

Tel: 949 858-8820 • [www.forespars.com/ttpower](http://www.forespars.com/ttpower)

# The Cup is coming – slips are going!



Making boating easier – and more fun! – is what Oyster Cove is all about.

America's Cup boats are already here! Take advantage of Oyster Cove's great location. Near the races and practices, as well as SFO and mass transit, Oyster Cove is the private marina best for America's Cup convenience.

## OYSTER COVE MARINA

385 OYSTER POINT BOULEVARD #8A,  
SOUTH SAN FRANCISCO

(650) 952-5540

- Berths 30 feet to 60 feet
- Double Finger Concrete Slips
- Five Minutes from SFO
- Close to Mass Transit
- Heated Dressing Rooms & Showers
- Laundry Room
- Nightly Security Patrol
- Complimentary Ice

[www.oystercovemarina.net](http://www.oystercovemarina.net)



## Save Your Aft!

Using one of our 1900+ patterns or your own pattern, let our craftsmen create a comfortable, durable, and stylish set of all-weather cushions for your cockpit. Find your custom, closed cell foam cushions at [www.bottomsiders.com](http://www.bottomsiders.com)!

## BottomSiders

BottomSiders  
2305 Bay Avenue  
Hoquiam, WA 98550

Call Toll Free: (800) 438-0633  
[cushions@bottomsiders.com](mailto:cushions@bottomsiders.com)  
Fax: 360-533-4474

## ATLANTIC 57 CATAMARAN™



THE ORIGINAL PILOTHOUSE CATAMARAN  
o Designed for easy shorthanded cruising  
o Spectacular windward performance  
o Cored epoxy/glass/carbon construction

CHRIS WHITE DESIGNS  
TEL: 508-636-6111

[www.chriswhitedesigns.com](http://www.chriswhitedesigns.com)

## Innovative marine products



### Mastlift & Accessories

Safest way to the top of a mast, you are in total control of your ascent and descent, work with both hands free, use as hoist for the dinghy motor, safely transfer mobility-challenged persons aboard, use in MOB rescues.



### Anchor Buoy Self adjusting

Do you know where your anchor is? You would with the self-adjusting Anchor Buoy from SWI-TEC! Precisely marks the anchor's set position and keeps other boaters at a distance. Can be used to a maximum depth of 65 ft.

Contact SWI-TEC America for  
• WASI Power Ball • PropProtector  
• WinchRite • Räber Meteograph

SWI-TEC America

INNOVATIVE MARINE PRODUCTS

[www.swi-tec.us](http://www.swi-tec.us)



BAR OPEN DAILY TILL 9 PM

LIVE LATIN MUSIC

Saturday & Sunday 5:30-8:30 pm  
with an outdoor BBQ 5-8 pm

WEEKENDS

Brunch Served 9:30 am-4:30 pm

WEEKDAYS

Lunch Served M-Th 11 am-3 pm

Fridays 11 am-3:30 pm

Happy Hour M-F 4-7:30 pm

Available for parties too!

(415) 621-2378

855 Terry François St., San Francisco

[www.theramprestaurant.com](http://www.theramprestaurant.com)

Like The Ramp on Facebook [www.facebook.com/TheRampSF](http://www.facebook.com/TheRampSF)

# THE RACING

The last weekend of September was so busy we could "only" cover the **FD Worlds**, **Melges PCCs**, **Express 27** and **Moore 24 Nationals**, and the **YRA Season Closer**. Phew! We'll also look at the **Vallejo 1-2**, the windless **Islander 36 Nationals**, the always colorful **Pink Boat Regatta**, and as much as we can cram into a painfully tight **Race Notes**.

## Flying Dutchman Worlds

As the wind went, so did the rate of success for Szabolcs Majthenyi and Andras Domokos. So, when gusts began to blow across the Monterey Bay in the final days of the Flying Dutchman World Championships, held September 25-30, they blew Majthenyi and Domokos straight to their eighth world title.

The Hungarian pair had sealed up the title before they finished third in a final race that featured the best conditions of the week, with sunshine, eight knots of breeze and a feisty swell. They tallied 15 points in the nine-race event that allowed two dropped scores.

Dutchmen Enno Krammer and Ard Geelkerken won the final race to sew up second with 18 points. Germany's Kay-Uwe Lüdtke and Kai Schäfers (21) took third overall, Italian brothers Nicola and Francesco Vespasiani (34) finished a distant fourth and Andrew McKee and Mathew Bismark (47) of New Zealand took fifth after finishing as runner-up in the final race of the regatta.

Santa Cruz skipper Philippe Khan teamed with Steve Bourdow and used local knowledge of the bay to take fourth in Race 9.

Majthenyi and Domokos have established a dynasty in Flying Dutchman World Championships, winning their third straight and eight of the past 11. The three other titles in that span were claimed by Jorgen and Jacob Bojsen-Moller of Denmark, who did not travel to Santa Cruz for the 2012 race.

At the outset of the 2012 champion-

of the 45-boat regatta. It wasn't until the second race of the second day — when winds picked up to 14-16 knots — that they overtook Krammer and Geelkerken on the beat and maneuvered to their first win.

"If the conditions are like this afternoon, it will be hard to beat the Hungarians," Krammer, who won in 1998 with a different teammate, said that afternoon in a bit of foreshadowing. "We're getting a little bit closer each year, but we need some luck."

The winds came and went, and occasionally were joined by thick fog patches. But neither those fluctuating elements, nor the surfer's-heaven swells — much different from the quieter lakes of Europe — threw the Hungarians off course. They took first and third, respectively, in Thursday's Race 5-6 coupling. After a lay day Friday for lack of wind, they won Saturday's opening race and took second in Race 8.

By Race 9 on Sunday, for Majthenyi and Domokos, it was nothing but smooth sailing.

— julie jag

## INTERNATIONAL FLYING DUTCHMAN OPEN WORLD CHAMPIONSHIP (9/25-30; 9r, 2t)

OVERALL — 1) **Majthényi/Domokos**, 15 points; 2) **Kramer/Geelkerken**, 18; 3) **Lüdtke/Schäfers**, 21; 4) **Vespasiani/Vespasiani**, 34; 5) **McKee/Bismark**, 47. (45 boats)

Full results at [www.sailifdco.com](http://www.sailifdco.com)

## SSS Vallejo 1-2

When a sportboat with a small PHRF



encountered. His Azzura 310 *Outsider* had stretched out on 51 other singlehanders, only to see the compression of the fleet gnaw away at his lead.

*Outsider*, rated 57, beat everyone else to the finish line off Vallejo YC at 2:42 p.m., but fell to last place in the Sportboat Division after the time-on-time calculations were applied. The fleet compression favored the boats with bigger handicaps, but to win you still have to prepare and sail your boat to its optimum ability. Garth Copenhaver on the 237-rated San-



Welcome to Parking Lot A of the Vallejo 1, with plenty of room to stay as long as you want.

ships, however, the Hungarian juggernauts couldn't be found in the standings. Confounded by spotty winds as quiet as 6 knots, they didn't finish among the top three in any of the first three races

number finishes a long-distance point-to-point race first and then corrects out last in division, you know there must have been a restart or two somewhere along the way. Parking Lot A at Pt. Pinole in the Vallejo 1 on Saturday, October 6, was the biggest of several wind holes Greg Nelsen

tana 22 *Oreo* did just that, and corrected out to first place overall.

Sunday's doublehanded race from VYC to RYC drifted down windless Mare Island Strait on an ebb, but the sailors





RICHARD PHILLIPS

### Sailors from around the globe descended on Santa Cruz for the Flying Dutchman Worlds.

found — and kept — enough breeze once they turned right into San Pablo Bay. With the absence of any significant wind holes, the boat that finished first stayed there once the math was done. Darren Doud and Chris Lewis on the Corsair 31R *Roshambo*, rated 33, finished at 1:30 p.m. and saved their time to win the Vallejo 2 overall.

But officially the Vallejo 1-2 is scored as a two-race regatta, and a boat from the middle of the ratings band corrected out to win the trophy for first place overall. Gordie Nash on the 135-rated *Arcadia* (which started life as a Santana 27 before Nash took a Sawzall to it) found himself in the middle of Lot A on Saturday — and that's where the wind filled in first. Wife Ruth Suzuki joined him on Sunday. "We hit all the wind shifts right," they said.

— *latitude/chris*

### SINGLEHANDED SAILING SOCIETY VALLEJO 1-2 (Oct. 6-7)

NON-SPINNAKER — 1) **Zingaro**, Santana 22, Jennifer McKenna/Suzanne Lee, 2 points; 2) **Meritime**, C&C 30 Mk I, Gary Proctor/Wayne Vanloon, 4; 3) **Hatikvah**, Cal 29, Scott Cyphers/Bill Gutoff, 7. (5 boats)

SPINNAKER PHRF  $\geq 153$  — 1) **Oreo**, Santana

22, Garth Copenhaver, 4 points; 2) **Eyrie**, Hawkfarm 28, Synthia Petroka/Ella Van Gool, 4; 3) **Wuvulu**, Islander Bahama 30, John New/Dawn Chesney, 6. (10 boats)

SPINNAKER PHRF 111-150 — 1) **Arcadia**, Mod. Santana 27, Gordie Nash/Ruth Suzuki, 2 points; 2) **Moonshadow**, Wylie 31, David Morris, 4; 3) **Solar Wind**, Martin 32, Max Crittenden/Roger Schmidt, 7. (7 boats)

SPINNAKER PHRF  $\leq 108$  — 1) **Timber Wolf**, Farr 38, David Hodges/Scott Parker, 2; 2) **Razzberries**, Olson 34, Bruce Nesbit, 6; 3) **Racer X**, J/105, Rich Pipkin/Mary McGrath, 6. (5 boats)

SPORTBOAT — 1) **Max**, Ultimate 24, Bryan Wade/John Pytlak, 4 points; 2) **Flight Risk**, T650, Ben Landon/Blake Davis, 9; 3) **Dragonsong**, Olson 30, Sam McFadden/Mike Brennan, 10. (11 boats)

EXPRESS 27 — 1) **Dianne**, Steve Katzman/Jarrian Westfall, 4 points; 2) **Take Five**, Donald Carroll/Mike Bruzzone, 7; 3) **Verve**, Ron Snetsinger/Michael Singer, 7. (7 boats)

WYLIECAT 30 — 1) **Uno**, Steve Wonner/Ross Craig, 3 points; 2) **Life Is Good**, Andy Hall/Chris Penn, 5; 3) **Dazzler**, Tom Patterson/Sue Estey, 6. (7 boats)

MULTIHULL — 1) **Roshambo**, Corsair 31R, Darren Doud/Chris Lewis, 5 points; 2) **Bobanja**, Corsair F-24, Robert Hyde/Anja Thiel, 5; 3) **Ma's Rover**, Corsair F-31, Mark Eastham, 6. (3 boats)

OVERALL — **Arcadia**. (65 boats)

Full results — [www.sfbayss.org](http://www.sfbayss.org)

### Islander 36 Nationals

What is happening right in the Bay Area racing scene is the positive use of social networking to organize owners in

fleets that diminished long ago. Case in point is the Islander 36 fleet which, back in its heyday, featured now-prominent J/105 sailor Bruce Stone as its last-place but most-improved sailor of the year — but that was something like 1982.

Today Dan Knox has worked hard to organize the current owners so they might once again hold what they call the Islander 36 National Regatta. A decidedly less competitive crowd, the cohesive and inclusive group of 11 boats competed on October 14 with the involvement of an additional seven boat owners to help organize this year's event.

Now, one race does not a national championship make, but on the other hand this group of sailors is out sailing together and by all accounts they have a lot of fun.

In the spirit of inclusiveness, the fleet allowed skippers to sail with or without spinnakers to build participation. We're not really sure how that works out but, hey, they make their rules and it's all good.

The race was intended to start south of the Bay Bridge. But with no breeze, everybody decided to shift to the north of Treasure Island, cut Blackaller to shorten the course, and instead sail around Alcatraz as the new weather mark.

A building ebb caused another delay as the start pin wouldn't set, but finally the fleet set off in a 10- to 12-knot westerly and made short work of rounding The Rock. With the finish set at the Encinal YC, the racers all had their work cut out as it was late in the day and well into the ebb.

It seemed the four boats that sailed Spinnaker would make a go of it but, one by one, boats dropped out and began to motor to the finish/party. Only Alameda's Kit Wiegman aboard *Cassiopeia*

For more racing news, subscribe to 'Electronic Latitude' online at [www.latitude38.com](http://www.latitude38.com).

October's racing stories included:  
Melges 32 Worlds

- Audi Melges 20 Nationals
- Great Pumpkin Regatta • ISAF Sailors of the Year Nominations
- Joan Storer Regatta • Kiteboard Course Racing Worlds • Vanguard 15 Championship • J/105 NAs • Fall Dinghy & Olympic Classes • YRA Champion of Champions/Yankee Cup • Oktoberfest/Multihull Regatta
- Corkscrew Slough • Race Previews and much more!

# THE RACING

ALL PHOTOS ROXANNE FAIRBAIRN UNLESS NOTED



RONNIE SIMPSON



**Pretty in pink** — (clockwise from top) Katie Love's 18-ft skiff 'Love Machine' walked away with five awards, including 'Pinkest Boat'; wacky and wild was the theme on 'Wayward Whale'; 'Green Buffalo' trampled the competition, placing first in class and overall; first in class winner 'Just Em' just wanted to have a good time and support a good cause; it's all about the after-party; the fleet enjoyed the clearing skies after a dreary start; (center) Jack Everett is one of the regatta's biggest cheerleaders; Dureen Webb and Lucie Mewes, who took third in division aboard 'Georgia', know all too well what it takes to battle cancer.

was able to snake down the Estuary to gain the title, Islander 36 2012 National Champion.

That ought to look good on his mantle.

— dave wilhite

## Pink Boat Regatta

October was National Breast Cancer Awareness Month, so it was quite fitting to see the 2nd Annual Pink Boat Regatta scheduled smack dab in the middle of the month. Hosted by the Corinthian YC and sailed just off Tiburon, the 17-boat fleet sailed laps between Belvedere Cove and Pt. Knox for three hours. With racers earning a point for each buoy they rounded, in addition to being able to "buy" buoys at \$100 apiece, it's safe to say that the Pink Boat is not your aver-

age regatta!

October 14 started out as a grey, windless morning but cleared and turned into another beautiful and sunny day of breeze-on San Francisco Bay sailing. From the outset, it was abundantly clear that one boat was in a class of its own: Katie Love's Aussie 18 skiff *Love Machine*, which was painted pink, including the sails, just for the regatta! Leaving the fleet in her wake, *Love* sailed 10 laps around the course, rounding an incredible 40 marks. In the process, *Love* claimed five awards, including pinkest boat, most marks rounded and best performance by a woman-skipped boat.

The second-fastest boat on the course was Jim Quanci's venerable Cal 40 *Green Buffalo*, skippered by wife Mary Lovely. Romping around the course to round 29

marks, the mostly female crew raised enough money to buy 18.6 buoys and win the A-Cup class and overall with 47.6 points. They narrowly edged out Terri Griffith's Ericson 38 *Wayward Whale* by one-tenth of a point. How's that when you can buy a regatta win!

In the C-Cup class, it was *Wayward Whale* taking a resounding class win with Alan Barr's Beneteau First 34.5 *Voyager*, sailing with Pink Boat founder Thomas Watson onboard, claiming second in class. Taking the DD-Cup class win was Ted Goldbeck's Cal 20 *Just Em*, which signed up the morning of the race and still managed to raise \$600 toward the cause.

Organizers once again threw a rockin'



after-party with a live band, silent auction and all of the ambiance that only CYC's race deck can provide. The Pink Boat Regattas have now raised over \$50,000 in 2012, with proceeds to benefit The Breast Cancer Research Foundation's search to find a cure. The next Pink Boat Regatta will be held in the spring of 2013 in San Diego.

— ronnie simpson

#### PINK BOAT REGATTA (10/14)

OVERALL POINTS — 1) **Green Buffalo**, Cal 40, Mary Quanci, 47.6 points; 2) **Wayward Whale**, Ericson 38, Terri Griffith, 47.5; 3) **Love Machine**, 18' Skiff, Kathleen Love, 41. (17 boats)

A-CUP (PHRF <125) — 1) **Green Buffalo**; 2) **Love Machine**; 3) **Georgia**, Van de Stadt 41, Lucie Mewes, 35.5. (5 boats)

C-CUP (PHRF 125-175) — 1) **Wayward Whale**; 2) **Voyager**, Beneteau First 345, Alan Barr, 33.15; 3) **Stink Eye**, Laser 28, Christine Weaver, 29. (7 boats)

DD-CUP (PHRF >175) — 1) **Just Em**, Cal 20, Ted Goldbeck, 28 points; 2) **Tortuga**, Westsail 32, Randy Leasure, 27.25; 3) **Road Runner**, Ranger 23, Lorraine Weiss, 25.75. (5 boats)

Full results at [www.pinkboat.org](http://www.pinkboat.org)

#### **Melges 20 PCCs**

Corinthian YC hosted the Melges 20 PCCs over the beautiful, if decidedly mellow, weekend of September 29-30. Though nine boats had pre-registered for the event, only eight showed up to the starting line — a bit surprising considering their Nationals were the following weekend.

Over at the Circle on Saturday, lack of wind forced a two-hour delay to the start while waiting for the breeze to fill in, which it finally did. The fleet was able to complete four races that day in winds up to 20 knots, which gave the competitors a good workout, especially the crew on Danny Shea's Kentfield-based *Diamante*, who suffered a broken rudder (they were

able to repair it for Sunday's racing).

There were more delays on Sunday, but the breeze kicked up earlier and topped out at 18 knots, allowing time for three races before the racers returned to the barn for the awards ceremony.

The notable news for this fleet was the fact that no one broke a mast. A rudder yes, mast no.

— jeff zarwell

#### AUDI MELGES 20 PACIFIC COAST CHAMPIONSHIP (9/29-30: 7r, 11)

OVERALL — 1) **Atlas**, Brian & Melissa Hill, 7 points; 2) **BLAST!**, Roland Vandermeer, 8; 3) **Flyg-fisk**, Tom Kassberg, 20; 4) **Kuai**, Daniel Thielman, 21; 5) **Problem Child**, Elliot James, 23. (8 boats)

Full results at [www.melges20.com](http://www.melges20.com)

#### **Express 27 Nationals**

A bit of Santa Cruz hit the Bay in September with both the Moore 24s and Express 27s running their Nationals a little north of their birthplace on the same

# THE RACING

weekend, September 28-30. The Express 27s ran a long Bay Tour course on Friday with the start near the XOC mark in the Berkeley Circle, a beat up to Yellow Bluff, a jibe at Blossom Rock and back down and around the Circle. "I wanted a long course with no islands and no bridges," said PRO Fred Paxton of host club, Richmond YC. "I was feeling pretty warm and fuzzy about it."

The racers had plenty of challenging conditions, with shifty light wind around Yellow Bluff, followed by plenty of breeze for a tricky jibe around Blossom Rock.

On Saturday and Sunday, the fleet was treated to windward/leeward courses in the Circle, with building breeze. Saturday's wind didn't get much above 15 knots, but subjectively it felt more like low 20s to the racers, who were drenched and tired from the steep ebb chop. "The waves were a little stacky," said Aaron Lee, who sailed on the Express 27 *Ergo*.

Scott Parker's *Freaks on a Leash* broke their spinnaker pole during Saturday's last race and had to sail the last run with Dominic Marchal serving as a human spinnaker pole. They doused for the



WWW.NORCALSAILING.COM

**The Express 27 plug 'Dianne' (hull number 0), sailed by Steve Katzman of Meyers, was among 22 boats bashing about on the Berkeley Circle at the end of September.**

jibe, then got bored and reset. A generous competitor lent them an extra pole for Sunday, which turned into a repeat of Saturday, with the strong ebb causing some nasty wind waves and only two races completed in order to get the tired

folks home.

At the end of all the bashing, Jennifer McKenna, foredeck on *Wetsu*, her hair dripping saltwater on the carpet in RYC's lounge, summed it up. "It was awesome!" she said through clenched teeth.

— ncs

## **EXPRESS 27 NATIONALS (9/28-30; 5r)**

OVERALL — 1) **Shenanigans**, Bill Moore, 10 points; 2) **Wile E Coyote**, Dan Pruzan, 17; 3) **El Raton**, Ray Lotto, 23; 4) **Get Happy!!**, Brendan Busch, 23; 5) **Freaks on a Leash**, Scott Parker, 28. (22 boats)

Full results at [www.express27.org](http://www.express27.org)

## **Moore 24 Nationals**

Bart Hackworth has been sailing Moores for over a decade and, with the help of co-owner Simon Winer's excellent sail trim, Rowan Fennell's tactical input and Guillaume Cavinet's near-flawless foredeck work, *Gruntled* claimed the 2012 Moore 24 Nationals, held at the South Beach YC September 28-30.

"The whole weekend was a bit amazing," said Hackworth. "I'd heard that the

# JUST YOU AND THE SEA...

...and the jacuzzi,  
the 80-ft long pool, the surf,  
the Punta Mita anchorage, and the 4-mile distant  
Tres Marietas Islands

## Punta Mita Beachfront Condos

Call Doña de Mallorca for reservations!

1.415.599.5012

[www.puntamitabeachfrontcondos.com](http://www.puntamitabeachfrontcondos.com)

*Pegasus* guy was tough but we had never sailed against him, and we knew Scott Easom on *Mas!* and John Kernot aboard *Banditos* would be right in the mix, too," he said. "Everything worked out great and we had the regatta pretty well sewed up by the last race."

In fact, the team assembled aboard *Gruntled* had never before sailed together as a group, even though they'd known each other for years. Where Kernot figured that the main reason they had not sailed well in the regatta was lack of practice, Hackworth's group gelled by sailing the Wabbit Nationals just the week before, which gave them crucial time on the water prior to the event. "Simon adapted quickly and was able to give us great boatspeed right off the bat, which was a major factor for us," said Hackworth.

The first race of the series was considered the 'long distance' event that had the 14-boat fleet sail out to Pt. Bonita from a start off the end of Treasure Island and the finish off the clubhouse. In what will go down as one of the best rides in a while, the teams were treated

to 20+ knots of breeze and a stiff ebb, which created a short chop and mad planing conditions. "The fleet was absolutely lit up," said Kernot.

Everybody we talked to seemed to agree that SBYC had run a great regatta, reeling off races in an almost workmanlike fashion and, despite congested conditions close to AT&T Park and the lack of a local hoist, the event proved reward enough to those who braved the urban conditions.

— dave wilhite

MOORE 24 NATIONAL CHAMPIONSHIP (9/28-30; 6r)

OVERALL — 1) **Gruntled**, Bart Hackworth, 8 points; 2) **Pegasus MotionX**, Mark Christensen, 9; 3) **Mas!**, Mark English, 11; 4) **Banditos**, John Kernot, 22; 5) **Double Trouble**, Kevin Durant, 25. (14 boats)



ERIK SIMONSON / WWW.PRESSURE-DROP.US

**The Moore 24 fleet battled brisk conditions and a crowded Bay for their Nationals in September.**

Full results at [www.moore24.org](http://www.moore24.org)

**YRA Season Closer**

Remember these numbers: 36, 49, 123. They're important numbers from Saturday's race in this year's YRA Party Circuit Season Closer hosted by the Corinthian YC the last weekend of September.

- 123 = The number of boats entered.
- 49 = The number of boats started.
- 36 = The number of boats finished.

**DeWitt**

**A Wonderful Gift Is  
ART!**

**Originals or  
Giclée Prints –  
to discuss, call Pam.**



*"Ducks in a Row" only available  
as a Giclée Print.*

**DeWitt Art Gallery & Framing**

121 Park Place, Point Richmond, CA 94801

(510) 236-1401 📞 [www.DeWittAmericasCupArt.com](http://www.DeWittAmericasCupArt.com)

Wednesday-Saturday 11:00-6:00 📞 Sunday 11:00-5:00

# THE RACING

A far cry from what the scene at the Corinthian YC just five years ago, where the fleet would fill the entire basin over this regatta weekend.

On the plus side, the race was the first outing for a certain Memo Gidley aboard his newly acquired Sausalito-based custom Elliott 10.50 *Basic Instinct*. If the Gidley name sounds familiar, then you've heard of Sausalito's Cass' Marina but what is interesting is that Memo, Cass' son born just after Cass turned 60, is better known in the world of car racing.

Gidley's crew consisted of tactician Gary Gebhard, trimmers Taylor Joy and Bob Lesnett, and Memo's mom, first mate and 70-something-year-old Mary. "We were a little short-crewed to be racing this class but we all decided we would just take our time and go for it," said Gidley.

With a third on Saturday in one of the most hotly contested divisions, this new team is a welcome addition to the fleet.

Sunday's "Crazy 8" pursuit race featured a course where contestants chose one of two figure-eight directions to sail around Angel and Alcatraz Islands. The



ERIK SIMONSON / WWW.PRESSURE-DROP.US

**Memo Gidley's 'Basic Instinct' placed second in class in their first race, the YRA Season Closer.**

day offered consistent breeze and favored the big-waterline boats as Division A dominated the starters.

John Clauser and Bobbi Tosse's Berkeley-based 1D48 *Bodacious+* won the 12-mile course, finishing almost two minutes in front of William Helvenstine's San Francisco-based Santa Cruz 50 *De-*

*ception*, closely followed by SFYC's Mary Coleman aboard her Farr 40 *Astra*.

— dave wilhite

## YRA SEASON CLOSER I (9/29)

PHRF 1 — 1) **Astra**, Farr 40, Mary Coleman; 2) **Encore**, Sydney 36, Wayne Koide; 3) **Basic Instinct**, Elliott 10.50, Memo Gidley. (9 boats)

PHRF 2 — 1) **Mintaka 4**, Gerry Brown, Farr 38; 2) **Jarlen**, J/35, Robert Bloom; 3) **Red Cloud**, Farr 36, Don Ahrens. (5 boats)

PHRF 3 — 1) **Arcadia**, cust. Nash 28.5, Gordie Nash; 2) **Ahi**, Santana 35, Andy Newell; 3) **Iolani**, Hughes 48, Barry Stompe. (9 boats)

PHRF 4 — 1) **Siento El Viento**, C&C 29, Ian Matthew; 2) **Mission Impossible**, Merit 25, Dave Hamilton; 3) **Byte Size**, Santana 22, Anna Alderkamp. (5 boats)

SPORTBOATS — 1) **Ragtime**, J/90, Trig Liljestrand; 2) **Frequent Flyer**, Farr 30, Stan Phillips; 3) **Vitesse Too**, Hobie 33, Grant Hayes. (5 boats)

EXPRESS 37 — 1) **Golden Moon**, Bill Bridge/Kame Richards; 2) **Stewball**, Bob Harford; 3) **Elan**, Jack Peurach. (4 boats)

ISLANDER 36 — 1) **Windwalker**, Richard Shoenhair; 2) **Califia**, Tim Bussiek; 3) **Luna Sea**, Daniel Knox. (3 boats)

SF 180s — 1) **Zeehond**, Newport 30-2, Donn



**SPECTRA**  
WATERMAKERS™

**EFFICIENT. POWERFUL.**  
**UNSURPASSED CUSTOMER SERVICE.**

[www.spectrawatermakers.com](http://www.spectrawatermakers.com)

## Mathiesen Marine

For all of your electronics and electrical needs

Sales & Installation of all major brands of marine electronics

Electrical system Troubleshooting & Repair

PC & Mac based Navigation Systems

Corrosion issues, Inverters, Battery Banks

Visit our showroom located at 3300 Powell Street, Emeryville

(510) 350-6622 [www.MathiesenMarine.com](http://www.MathiesenMarine.com)







New and Used Sails.



Specializing in Sail Repair and Service.

**Marchal Sailmakers**

2021 ALASKA PACKER PLACE, ALAMEDA, CA 94501  
Dominic Marchal • (510) 239-5050  
[www.marchalsailmakers.com](http://www.marchalsailmakers.com)

HAWAII

## LONG TERM DRY STORAGE

Clear Customs at our dock

Available Now!

**GENTRY'S KONA MARINA**

HONOKOHAU HARBOR 156°1'30" W  
19°40'20" N

TOLL FREE 888-458-7896

[www.gentryskonamarina.com](http://www.gentryskonamarina.com)

The friendliest boatyard in Hawaii

Guay. (2 boats)

SF 30s — 1) **Shameless**, Schumacher 30, George Ellison. (3 boats)

SHORTHANDED — 1) **Nancy**, Wyliecat 30, Pat Broderick. (2 boats)

NON-SPINNAKER — 1) **Q**, Schumacher 40, Glenn Isaacson. (2 boats)

**YRA SEASON CLOSER II (9/30)**

OVERALL — 1) **Bodacious+**, 1D48, John Clauser/Bobbi Tosse; 2) **Deception**, SC 50, William Helvestine; 3) **Astra**, Farr 40, Mary Coleman. (40 boats)

Full results at [www.yra.org](http://www.yra.org)

### Race Notes

The Race Committee elves at St. Francis YC had their hands full on the weekend of October 13-14. In addition to running the Jessica Cup for big woodies (see page 88), they ran the **Albert T. Simpson** for Etchells and Express 27s, **Joe Logan** for Mercuries and **Calvin Paige** for Stars. Seven Mercs sailed four races, and Randy Smith's *Fast Break* from SFYC squeaked by Doug Baird's *Axon* by just one point. Another SFYC boat, Jim Cunningham's USA 1404,

topped the seven Etchells, and StFYC's Ray Lotto added another notch in his belt with the Express 27 *El Raton*. The Star class failed to make an appearance.

Stan Honey of Palo Alto and John Kostecki — a long-time Marinite who now calls Reno home — were inducted into the **National Sailing Hall of Fame** on October 14. Kostecki, tactician for America's Cup defenders Oracle Team USA, was still smarting from a capsiz in the AC World Series. Kostecki's won the "Triple Crown" or "Grand Slam" of sailing — an around-the-world race (the 2002 Volvo Ocean Race aboard *illbruck*), the America's Cup (AC 33), and an Olympic medal (silver in the Soling class of 1988) — which is something no other sailor in the world has done. Besides his innovations in TV technology that have led to two Emmy Awards, Honey was the navigator for the 2006 Volvo Ocean Race-winning *ABN Amro One* and 2010's record-breaking circumnaviga-

tion aboard the trimaran *Groupama 3*. Visit [www.nshof.org](http://www.nshof.org) for much more.

Berkeley YC hosted the YRA's **Champion of Champions** and **Yankee Cup** races on October 20. Light winds ended the day after the completion of two out of three races. Trig Liljestrand's J/90 *Ragtime* topped PHRF 1, and George Ellison's Schumacher 30 *Shameless* won in PHRF 2. If you finished a YRA race this year in a podium position, chances are they have a prize for you. The **Year End Trophy Party** will be held at Berkeley YC on Wednesday, November 14, at 7:00 p.m.

The **Ultimate 20** Class Association has announced that W.D. Schock of Newport Beach will be the official North American builder for the mid-'90s Jim Antrim design. Hulls #250 and 251 are currently under construction. See [www.u20class.org](http://www.u20class.org) for more info about this fun sportboat.

Our usual year-end coverage of **season champions** will begin in the December issue.

— *latitude/chris*

FAST SHIPPING!

## NEW AND USED SAILS!

Specializing in production boats and featuring the largest selection of stock sails available anywhere! Save with warehouse volume discounts on Stock Sails, Custom Sails, Sail Covers, Furlers and Accessories. All top Quality.

**All Fully Guaranteed!**



**THE SAIL WAREHOUSE**

- Full Batten Mains
- Furling Genoa's
- Storm Jibs
- Trysails
- Furling Units
- Custom Canvas
- Used Sails



## THE SAIL WAREHOUSE



Ph. (831) 646-5346    [www.thesailwarehouse.com](http://www.thesailwarehouse.com)

## Bilge Steam Cleaning    Oil Changes

Professional service at your slip!!!

MarineLube

877 744-2244

[www.MarineLube.biz](http://www.MarineLube.biz)





### Fuel Polishing

### Tank Cleaning

## WEDLOCK, RAMSAY & WHITING

### Marine Surveyors

Vessel surveys,  
consulting, deliveries.



Serving the  
Bay Area  
since 1980



[www.norcalmarinesurveyors.com](http://www.norcalmarinesurveyors.com)

(415) 505-3494

# VOLVO PENTA

ENGINES • PARTS • SERVICE

## 1-800-326-5135

We Ship  
Anywhere

(415) 453-1001  
FAX: (415) 453-8460  
[www.helmutsmarine.com](http://www.helmutsmarine.com)  
619 Canal Street  
San Rafael, CA 94901



**MARINE SERVICE** INC

AUTHORIZED POWER CENTER

# WORLD

With reports this month on **Escaping to the Sunny Caribbean**, and a two-family 'kids' charter' in **Spain's Balearics — a Favorite Mediterranean hot spot**.

## Chase Away the Winter Blues With a Tropical Sailing Getaway

Now that days get shorter, temperatures drop and skies overhead become gray and gloomy, you're probably starting to yearn for those sunny days of summer. But there's no need to get in a funk, because we've got a surefire method for chasing away the winter blues: Shanghai a boatload of your favorite friends or family members and jet to a tropical charter destination for a week or more of barefoot fun.

While it may be the 'melancholy season' here at home, it's peak season down in the sunny latitudes of the Eastern Caribbean where a 500-mile stretch of islands — from Puerto Rico to Grenada — offer trade wind sailing under brilliant blue skies.

If your vacation options are constrained by school holidays, you'll find there are still some bareboats available for the two weeks that encompass Christmas and New Year's. But if your schedule is flexible, you'll save money on both boats and flights, and will see fewer boats in the anchorages, if you avoid that period, which is the busiest two weeks of the year for bareboat and crewed yacht charters, as well as shoreside vacationing.

In addition to the popular charter bases in the U.S. and British Virgin Islands, you'll find charter bases at Grenada.

**Starting to get the winter blues? Why not set your sights on the Eastern Caribbean, where the water's warm and the skies are sunny.**

The Grenadines, St. Lucia, Antigua, Guadeloupe, Martinique and St. Martin. We've sailed all along this volcanic island chain and we can testify that each venue has its own distinct charms and cultural heritage. If you're looking for solitude, the farther south you go, the fewer boats and shoreside travelers you'll find.

In order to maximize the number of islands and micro-cultures you might visit, consider organizing a one-way charter up or down the island chain. Wherever you choose to sail, though, we'd love it if you'd drop us a line, with a couple of photos, and share a few insights and anecdotes. Smooth sailing!

— andy

## Breezin' Through the Balearics: Mallorca, Ibiza & Formentera

My good friend Marco Salvalaggio suggested that we plan a sailing charter with our kids in Spain's Balearic Islands, which include Menorca, Mallorca, Ibiza and Formentera. In early July we found ourselves island-hopping through the western Med, on a week-long cruise out of Palma, Mallorca, that covered 210 miles.

We chartered through a broker — Cosmos ([cosmosyachting.com](http://cosmosyachting.com)) — although in hindsight we probably could have saved some money by going directly through the charter company that handled the boat, Viva Yacht Charters ([vivacharter.com](http://vivacharter.com)). We wanted a 50-footer, and went with a 2008 Bavaria named *Fora Nirvis*. While in Palma, we noticed there are

numerous charter companies, so you have lots of options, although the charter companies we often use, The Moorings and Sunsail, do not have a base in the Balearics.

We were a crew of seven, including me, Marco, his 15-year-old daughter Daniela, her friend Claire, my daughter Claire, 20, and her friends Prakash, 20, and Tomek, 24. Marco, Daniela and Claire flew down from London and Tomek came from Warsaw. My daughter Claire and Prakash had joined me earlier in Barcelona for a few days of sightseeing and



ALL PHOTOS COURTESY ART HARTINGER

tapas-sampling before flying on to Mallorca. We all made a rendezvous at the airport in Palma, Mallorca (PMI). The flight from Barcelona (BCN) to PMI only takes about thirty minutes, and there are lots of schedules and airlines to choose from including Vueling, Iberia, and Ryan Air.

Palma itself is located on a huge bay that's about 10 miles across, with lots of marinas and a big yachting scene. Marco brought an excellent pilotage guide that's simply titled: *Isla Baleares: Ibiza, Formentera, Mallorca, Cabrera and Menorca* by Graham Hutt (published through the RCC Pilotage Foundation / Imray Laurie Norie & Wilson). I wholeheartedly recommend it, although I believe it is expensive. This guide has incredible detail, and appeared to be accurate in all respects, with dozens of useful GPS waypoints.

One tip I can pass along to charterers and other sailors with limited time in this area: Don't forget to get a permit in advance for cruising Cabrera, islands that are part of a national marine preserve just south of Mallorca. We had been led to believe that we could get a permit before we departed from Palma,



LATITUDE / ANDY



# OF CHARTERING



**A week full of contrasts. Spread: Formentera's spectacular beaches. Insets: Claire and Prakash take a swim off the stern; the busy harbor at Palma with its grand cathedral.**

but were told there was no way to do so at the last minute. Everything had been fully booked for at least two weeks. But we vowed to return so we could see those waters.

Our plan was to circumnavigate Ibiza, with a side trip to Formentera. I have been spoiled by the Caribbean, but this trip was an eye-opener. We encountered great winds daily of 8 to 20+ knots, and warm water. I hope to return because the sailing is fantastic, and the beaches are among the most beautiful I have ever seen. I wouldn't be surprised if the beach at Formentera rates in the top 10 in the world.

Our checkout from Viva Charter was a tad unusual. A staffer named Henry instructed us to inventory the boat equipment. He then collected money: 2,500 euros as a damage deposit, 90 euros to rent an outboard motor for the dinghy, and more money for linen and towels.

After making sure our credit cards went through, he asked, "Do you have any questions?" That was it. We had a

few questions about the main roller-furler procedure and other boat systems, but we promptly shoved off. We'd been pretty anxious to get going anyway, as the marina was hot and tightly laid out, with all boats inches apart and berthed stern-to.

We had no complaints with our big, comfy Bavaria, but unfortunately our dinghy leaked so badly that we had to pump it up every time we launched it.

We shoved off and sailed in about 10 knots of wind roughly five miles toward the mouth of Palma Bay to Cala Portals. We all went for a swim, Tomek made a great pasta, and we were finally underway on our cruise. This was a roly anchorage, but we really had no other choice as we'd left after 4:30 p.m., and this was better than staying at the marina.

The next morning we got up early and set sail at about 6:30 a.m., as we'd planned a 60-mile trip south to the famous isle of Ibiza. Along the way we had variable winds, although at times we saw 10 to 12 knots. Thirty miles out, the winds were so light that we let the kids

swim off the stern — with safety lines deployed, of course.

After a long day we finally arrived in Cala Portinatx, a small bay with a beach, "supermarkets," and beach bars. We launched the dinghy, and the kids went in to get some extra provisions and explore.

Cala Portinatx is on the north coast of Ibiza. It's a beautiful little bay, with easy anchoring, clear water, and places to provision. It's very low key and even quaint compared to the larger Ibiza Town and San Antonio.

The kids went ashore for dinner that night, while Marco and I stayed behind to cook some chicken and sausages. It turned out we had four vegetarians on board! Yeah, we screwed up the provisioning by ordering too much meat.

The next day was Daniela's 15th birthday. Marco had made arrangements to go to Pacha ([pacha.com](http://pacha.com)) — a famous nightclub in Ibiza Town — as a birthday present. We dinghied in for fresh croissants, then weighed anchor for San Antonio. We'd considered going directly to Ibiza Town, but anchoring was reportedly difficult, and the marina was 400 euros per night (if we could get a spot). So the plan was to drop anchor in San Antonio, then power nap to prepare for Pacha — because, we learned, one does not go to Pacha before 1 a.m.

We had a great sail in 15-18 knots of wind. Upon arrival we found that the anchorage was crowded, but we noodled in and found a spot as close as possible

**The party scene at Ibiza has been notorious for decades. Where else can you find sexy dancers gyrating inside giant martini glasses?**



ART HARTINGER

# WORLD

to the dinghy landing. San Antonio is a zoo, with discos booming all night, and strange tourist attractions catering to the young party crowd.

After napping, we dinghied ashore about midnight and took a taxi to Ibiza Town for dinner. We got to Pacha about 1:30 a.m. and, although I was skeptical, it really was quite wild and interesting. The DJ, Tiesto, is rated one of the top five in the world, and the kids were thrilled. As an old fart I confess that I had not even heard of Tiesto. But there were thousands of people going wild in Pacha who proved that he is something of a sensation.

We got back to the boat about 6:45 a.m., and thankfully our sagging dinghy was still there among several people passed out from clubbing that evening.

Although it was probably a questionable decision, we decided to shove off because the next destination we'd planned to visit was only about 18 miles away: an anchorage off a famous place called "the Blue Marlin." The bay is called Jondal,



ART HARTINGER

**With 'Fora Nirvis' safely anchored at Cala Portinatx, the intrepid crew heads ashore to reconnoiter.**

and is located on the southwest side of Ibiza. After anchoring, we all quickly fell asleep, not waking up until about 1 p.m.

Cala Jondal has a rocky beach, but the scene ashore is lively, with the Blue Marlin ([bluemarlinibiza.com](http://bluemarlinibiza.com)) dominating. There was lots of 'action', with some large

yachts, both power and sail, around us. The Blue Marlin is a swanky, South Beach, Florida-type of place, with a DJ, models parading around wearing clothes from the onsite boutique, and good (but expensive) food.

Tomek spotted Steven Gerrard, captain of England's national football team, lounging with some other guys in a cabana. When Tomek tried to take his picture, he was promptly chastised by a bodyguard. But when I let them know I was American, and didn't even know Gerrard was a celeb, he kindly set up a photo opportunity for us. Tomek was ecstatic.

We set sail the next day for Formentera. It was only about eight miles to Isla Espalmador, which is just off the coast of Formentera. This is a beautiful spot, with a range of boats from megayachts to smaller boats the size of our Bavaria 50. Marco and I dropped the kids off to explore this truly beautiful beach, and we stayed on board to soak in the scene. Soon, the Veuve Clicquot girls arrived in

## Are "Californians Dreaming?"

Stop dreaming – go sailing.

**CALL TO RESERVE AT OUR  
BEST IN THE BVI PRICES!**



**Conch  
Charters**

[www.conchcharters.com](http://www.conchcharters.com)

**(800) 521-8939**



**BVI YACHT CHARTERS**

Call: +1 888 615 4006  
Or: +1 284 494 4289

BVI Yacht Charters is the first port of call for all yacht charters in the BVI and St Martin. Whether you are looking for a Catamaran or a Monohull, a week or just a few days, our professional team is on hand to make it work, your way.

## BVI YACHT CHARTERS

\*\* 10% off all new bookings when you mention this ad.

[www.bviyc.com](http://www.bviyc.com)

[charters@bviyc.com](mailto:charters@bviyc.com)

# OF CHARTERING

their runabout selling bottles of Champagne! That's not something that happens at every chartering destination.

At about 4 p.m., we had a short sail along a peninsula of beaches and sand dunes to Formentera. We dropped anchor off a spot with two beach resorts on shore, one of which is named the Restaurant Es Ministre. The long, beautiful beach had lounges for rent in front of the two businesses, with the usual euro-beach scene — as I'm coming to understand it — but with a relatively deserted strand that ranges north for two miles or so.

On the sixth day of our trip we opted to position the boat on the north side of Ibiza, so we'd be in a good position to sail back to the charter base the following day (Friday).

We enjoyed a 25-mile sail in 12 to 20 knots of wind, although it was mostly on the nose. We thought we'd anchor in the northeast, at Cala de San Vicente. However, the sea state was so roly that we opted to return to Cala Partinatx. It was nice to return to this charming anchorage, and it made our trip a true

circumnavigation of Ibiza. Tomek and Daniela paired up to make a fantastic pasta, and we went to sleep knowing that the next day we had a 60-mile passage back to Mallorca.

The alarm went off at 5:30 a.m., and we weighed anchor at 6 a.m. The sailing was close-hauled again, but the seas were relatively flat, and we made good time. Along the way, we made a stop at a harbor resort south of our marina to meet with the family of one of the kids, who were vacationing in Mallorca.

As we approached the charter base, we recalled that the instructions had been strict: Refuel the vessel at the fuel dock (which closes at 5 p.m.), and return the yacht stern-to no later than 6 p.m. or the credit cards would have to come out yet again. We made it to the fuel dock by



ART HARTINGER

**After a fun-filled week in the Balearics, the crew strikes a pose in the cockpit of their temporary floating home, a sweet-sailing Bavaria 50.**

4:55 p.m. and topped off the tank. The return to the marina was painless, with Marco at the helm as we came in stern-to — a flawless re-entry.

It was a great trip that gave us lots of happy memories. And although we're sorry that charter had to end, we're already thinking about the next one!

— art hartinger

**Real People. Real Sailing. Real Fun.**



Sail Cats | Power Cats  
Monohulls | Trawlers  
Bareboat | Skippered

**Real Choices.**

Choose CYOA and become part of the family. We've been providing beautifully maintained yachts, personal service and sensible prices to sailors since 1980.



1-800-944-2962  
info@cyoacharters.com  
www.cyoacharters.com  
St. Thomas USVI 00802

**CYOA**  
YACHT CHARTERS



Tortola BVI  
Belize  
The Grenadines

**UNIQUELY**  
**TMM**



Marisa  
TMM Belize

Most charter companies offer blue water & palm trees, but it takes the personalized care of people like Marisa to make your vacation a success.

Like Marisa, everyone at TMM is committed to your complete satisfaction. Our specialized three-location operation offers large company quality with small company service. A combination that is uniquely TMM.

**TMM**  
Yacht Charters  
Since 1979

**1.800.633.0155**  
www.sailtmm.com

catamarans • monohulls  
motor yachts  
ownership programs

# CHANGES

With reports this month from **Sea Level** at Rodrigues Island in the Indian Ocean; from **Geja** in Italy and Croatia; from **Fleetwood** back in Amsterdam; from **Witch of Endor** on getting a dinghy ripped off in Costa Rica; from **Larrikin** on a summer in the Sea of Cortez; from **Harmony** on tropical storm Paul in the Sea of Cortez; and **Cruise Notes**.

## Sea Level — Schionning 49 Cat Jim and Kent Milski Across the Indian Ocean (Lake City, Colorado)

With Somali pirates having curtailed cruiser interest in heading to the Med via the Red Sea, the only choices for westbound West Coast cruisers who are in Indonesia/Thailand/Malaysia are to

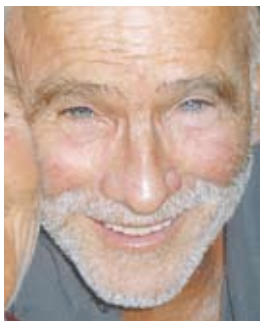

**Jim, cruising the cat he finished from a kit.**

sail home backward via the Pacific, which isn't that appealing, or continue west around the world via the Indian Ocean, the Cape of Good Hope, and up the Atlantic to the Caribbean. Since we'd already sailed more than half-way around the world, and it's easier to continue on than to backtrack, we're continuing west.

We're heading to South Africa via Rodrigues Island, where we are now, and Mauritius. Our last passage, from Sumatra, Indonesia to Rodrigues Island, was more than 2,000 miles. It was also our roughest passage to date. Cruisers who made the passage just before us or just after us reported the same rough conditions.

The problems were that it was windy and the sea conditions were not pleasant. It was so windy that all we ever flew was a double-reefed main and between one-half and one-third of the headsail. That's not much. The other issue was that we were getting a big swell from the southwest, but wind waves from

**Rodrigues Island — 400 miles to the east of Mauritius — has some nice beaches and scenery, but it's not a normal cruiser destination.**

the southeast, making for sloppy conditions.

We hove to for two nights. The first time was for comfort and to get some rest. One of the lesser publicized positive attributes of catamarans is that they are easy to keep pointed into the wind in bad weather. For example, we would roll up the jib completely, secure the double-reefed main amidships, center the rudders, then turn off everything except our navigation lights. In this configuration *Sea Level* would maintain a heading of about 30 degrees off the wind, and depending on the current and the strength of the wind, make one to two knots. We could control what tack we were on by moving the traveller to port or starboard of center. The constant motion was reduced to a minimum, which allowed us to enjoy a decent meal in relative peace, watch a movie, or get some sleep.

The second time we hove to was just off Rodrigues, and we did it for safety. We were going to be losing the last of daylight as we entered an unfamiliar port, and we didn't think that would be prudent. So as much as we wanted to enjoy the tranquility of a harbor, we hove to until the next morning.

A French cruiser who arrived off Rodrigues about the same time we did, decided that he would go in. His boat went up on a reef. We're happy to report that he, with the help of others, was able to get his boat off without her suffering too much damage. But we were happy with our decision.

Talk about lightning hitting the same place — or boat — twice! We just learned that our catamaran friends Greg and Debbie Dorland of the Tahoe-based *Catana 52 Escapade* had their boat hit by lightning for the second time — with predictable unpleasant results for much of the electronics — in three years. At last word they were in Florida, but we're hoping to cross paths with them in the Caribbean in January.

—jim 10/01/12

## Geja — Islander 36 Andrew Vik Summer In The Med (San Francisco)

When I left off last month's installment of my latest summer of cruising in the Med — more



specifically the Adriatic — my crew and I were thrilled to be back in Italy, where the people are so friendly and lively, and where the food is ridiculously delicious. On the downside, far fewer Italians are fluent in English than are residents of the former Yugoslavian countries.

After clearing in at Bari — no fuss and no cost to enter the European Union — we headed down the coast. It didn't take long before the horizon was a frothy white again, with 20+ knot winds and a nasty little swell. Once reefed down, it was an exciting and wet close reach. *Geja* rose and fell with the waves, sometimes taking a direct hit that sent spray back into the cockpit. We were soaked but satisfied, as *Geja* handled the conditions like a champ.

Unlike the steep-sided Croatian side of the Adriatic Sea, the Italian side is shallow with mostly man-made ports and virtually no islands. The approaches



# IN LATITUDES



PHOTOS COURTESY GEJA

**Insets left; Andrew Vik loves Italian food; loves little Italian ports such as Giovinazzo, where his Islander 36 was the biggest boat around; and loves Italian holiday playgrounds such as the Tremiti Islands. But when it comes to sharing his cruising adventures, he loves women of all nationalities.**

to the harbors can have as little as 10 feet of water, which makes entering precarious when five-foot swells roll in. We entered little Giovinazzo with not much drama, and took an awkward spot at the end of a floating pontoon, which required us to partially raft to a resident powerboat. I discovered Giovinazzo by accident in '10, and it quickly became one of my favorite spots in the Med. It's a small harbor where *Geja* was again the largest boat — something I can't often say in this part of the world.

It was no accident that we arrived during *Ferragosto*, the period in August when most industries shut down and Italians flee to the coast to escape the inland heat. As the late afternoon *siesta* wraps up, Italians of all ages converge on the nearest town for the nightly

*passaggiata*, which of course includes a stop at the *gelateria*. There is often some kind of program being presented in the town *piazza*, and on our first night in Giovinazzo, it happened to be the regional competition for the Miss Italy contest. My all-male crew and I were quite happy to hang around and root for our favorites!

My plan was to end the week at Trani, just a couple of stops up the coast, but the sea had other plans for us. The onshore wind and waves just didn't let up, and the harbor entrance was closed by breakers. So *Geja* was

stuck in Giovinazzo's surging harbor for two additional nights, and I constantly worried that the metal gudgeons on the end of the floating dock would poke a hole in *Geja*'s hull. But what a great town to be stuck in!

With another new crew and calmer weather, we had a great sail up to Trani, its famous seaside cathedral visible for many miles down the coast. The bars around the large harbor really get going at night, with one offering its own liquid concoction called Rocket Fuel — a far cry from the standard one-ounce pours in Croatia.

A bit of rain and scattered thunderstorms kept us in Trani for an extra night before we continued up to Vieste in dreamlike sailing conditions. A bustling hillside holiday town, Vieste had an excellent outdoor food market. The town's location on the 'spur' of Italy, only 60 miles from Croatia, makes it a popular place to head back across the Adriatic. But taking the direct route means missing Italy's Tremiti Islands, which are gems of the Med.

Spoiled by another day of perfect sailing conditions, including a fast spinnaker run, we opted to take the detour to the Tremitis. Those who say that the Med lacks wind should have been there when I was. During the eight-day span from Montenegro to these islands, we covered some 250 miles, 90% under sail.

The Tremiti Islands lie 13 miles off Italy's relatively featureless southeast coast. They consist of a cluster of five islands housing about 500 permanent

***The Tremiti Islands, 13 miles off Italy's otherwise featureless east coast, are one of Andrew's favorite nautical playgrounds.***



**Italian food — ridiculously delicious.**



GEJA

# CHANGES

residents, with visitors ferried in by the thousands during the summer months. One of the things to do there is to hop into the dinghy and do the four-mile circle around Isola San Domino, the coastline of which features coves, grottos, and sandy beaches. As a nautical playground, the Tremiti Islands are hard to beat. But you need stable weather, as the anchorages offer poor protection.

As we prepared to depart the Tremitis for the overnight sail back to Croatia, a dinghy pulled up for a visit. Two Italian men from a neighboring boat wanted to chat, and presented us with a nice bottle of white wine. *Geja*, thanks to her crusty looks and American flag, is no stranger to special attention. But then Italian hospitality never ceases to impress me.

Our overnight sail back to Croatia was for the most part sweet pleasure sailing, with 12 knots of wind on the beam in flat seas. I chose to check in at the town of Vis, where unlike Cavtat, these isn't a special customs quay. You just take a regular spot on the public quay and begin the three-step check-in process: harbormaster, police, and customs. The customs official seemed really cool at first, even suggesting that my crew get coffee while they wait. Take that, Cavtat!

While things began smoothly, slowly but surely, they started to go downhill when the beer-guzzling customs guy **Andrew found the Croatian anchorages — such as this beauty — to be more to his liking than the shenanigans of Croatian officials.**

asked me to run around town and photocopy some of my documents for him. Unable to find a place to get copies, I returned to his office pissed off. "If you really need copies, I'll email them to you," I stated angrily. Then I began to take photos of my documents with my iPhone.

"No, no!" said Mr. Customs man, but I kept snapping away. He then took my papers and walked away. I asked the policeman in the same office if the customs guy was normal. "Not really," he said with a confirming smirk. A few minutes later, the customs guy returned with photocopies, likely from his copy machine in an upstairs office. I chewed him out a bit before storming off, some two hours after beginning the check-in process. Mind you, my cruising permit from before was still valid. A Croatian bureaucrat had once again been a source of frustration. Hopefully some of this bureaucratic nonsense will disappear when Croatia is admitted to the European Union in '13.

Tired from the overnight sail, and pissed off due to the fat customs jerk, we continued on for another couple of hours to the Pakleni Islands — another of my favorite stops in the Med. Palmizana is a busy but relaxing bay with excellent restaurants lining the shore.

Just before weighing anchor the next morning, I was to enjoy one of the most pleasant surprises of all my time in the Med. An older Croatian sailor in a dinghy came alongside, and explained that 13 years before, he and his wife had invited Dick and Shirley Sandys, the Palo Alto-based previous owners of *Geja*, for dinner while their boats were anchored together in Palmizana. Unbelievably, he produced a note written by the Sandys from his scrapbook that read, "Hvala for dinner." *Hvala* being the Croatian word for 'thank you'. I often think of Dick and Shirley Sandys, and the crazy adventures they must have had while sailing *Geja* from California to the Med many years ago. This chance encounter blew me away!

Back in lively Hvar, my having closed the loop I'd begun four weeks earlier, my final crew of the season hopped on board. Though *Geja's* winter port near Split was just a day sail



**The Adriatic may not be that warm, but the water is clear.**



away, there were plenty of islands and attractions in between, which resulted in an easy and relaxing final week. Best of all, the weather forecast was as stable as I've seen, with clear hot weather — and none of the nighttime offshore *bora* winds that cause boatowners to lose sleep.

After overindulging once again in the town of Hvar, we relocated *Geja* to a nearby island, one that happens to be home to the Carpe Diem Beach Club. When the bars in Hvar shut off the music at 2 a.m., folks are shuttled to the beach club, where the festivities continue until 5 a.m. Anchored strategically near the club, we waited until folks began to arrive. At 2:30 a.m., we hopped into the dinghy, figuring that our stealth approach would save us the 20 euro cover charge. We had no such luck, as a guard intercepted us and led us to the cashier.

Halfway through the final week, having had several late nights out in a row, I sought out the quietest anchorage pos-



GEJA

GEJA

# IN LATITUDES



ALL PHOTOS COURTESY GEJA



**Clockwise from above: Nothing gives us more pleasure than seeing other people have fun — Andrew hams it up with three of his crew. The Sandys' 'thank you', note, still treasured after 13 years. The anchorage at Hvar, Croatia. A beautiful but cloudy sky marked the end of Andrew's 5th season.**

sible. Both of my pilot books led us to the east coast of the island Bra, and the sweet little bay called Rasotica. It was a great little playground for my crew — three fun girls and Big Steve, my buddy from high school.

The next night we were back to the bars in Makarska, a very happening place on the mainland. We took refuge before seeking quiet once again back on Bra at the adorable quarry town of Puiša. For centuries Croats built both streets and structures using their distinctive light-colored stone. In Puiša the art of stone-making is still very much alive. Even the White House in Washington, D.C. uses stone from there.

We enjoyed a wild Saturday night out in the town of Split before concluding the summer voyage at *Geja's* winter home of Trogir. We immediately rinsed and removed the sails just before a nasty little weather cell with 40-knot winds blasted

through the partially protected marina. It was the first truly crazy weather since I'd arrived four weeks before. Less than four days later, *Geja* was on the hard ready for winter, and I was on my way back to San Francisco.

Once again my 40+ year-old Islander 36 provided me with a trouble-free

summer — aside from some propeller shaft bolts that mysteriously loosened on the rough overnight crossing to Italy, and a bilge pump check valve that didn't appreciate being submerged for hours at a time. *Geja's* old Yanmar 3GMF must qualify as ancient by now, yet it purrs along without fail, partially thanks to regular seasonal maintenance performed at reason-

able rates by the boatyard crew. *Geja's* sails are hand-me-downs from the really nice members of the Islander 36 Association of San Francisco Bay. But they are quite decent. And what a sweet sailing boat the Islander 36 is!

As I mentioned in my last report, my fifth straight summer aboard *Geja* consisted of 37 days and 36 nights, with 27 different overnight stops and two overnight sails. I covered nearly 700 miles, 60% of them under sail alone — the highest percentage of the five summers. The best part has always been sharing the experience with friends, 10 of whom joined me this summer.

— andrew 10/15/12

## **Fleetwood — Naja 30 Jack van Ommen The Med To Amsterdam (Gig Harbor, WA)**

Some readers may wonder how far it is, how many locks you have to pass through, how long it takes, and how much fuel you need to motor a 30-ft sailboat with an unstepped mast from the Med coast of France to Amsterdam.

Having arrived in Amsterdam in early October after making the trip, I can provide answers based on my experience. It took me seven weeks and 1,000 statute miles to pass through France and Belgium via the Rhone, Saone, and various other waterways. During that time I transited a total of 251 locks, burned about 40 gallons of fuel, and spent about

***If your boat is narrow enough and doesn't draw too much, you can travel from the Med to Amsterdam via waterways such as this.***



GEJA

***When the social life became too hectic, Andrew would chill in the dink.***



PIERRE FRERE

# CHANGES

\$325 in mooring fees. Those interested in details of my trip north through France and Belgium should visit my blog.

Belgium became the 49th country that I have visited with *Fleetwood* since departing California in '05. I've lost track

of how many miles my boat and I have sailed together, but it's something close to 35,000, most of them singlehanded. I did, however, have company for the trip from the Med to Amsterdam.

After so much traveling, *Fleetwood* needs a lot of work. Her 33-year-old teak deck, for example, needs to be

removed. I hope to do this under cover in the spring. *Fleetwood* will spend the winter not far from Amsterdam.

I had planned to sail the Baltic Sea next summer, but after talking to a few of the members of the local yacht club, I am now planning to join them on a trip to Bretagne — northwest France — via the South Coast of England in June and July, then follow Spain's north coast to Portugal. In January of '14, I plan to take off from the Canary Islands for Cartagena, Colombia, where I will begin exploring South America by land.

— jack 09/15/12

## Witch of Endor — Vagabond 47 Steve Cherry Costa Rica, El Salvador (San Diego)

Bob Willmann of the Casamance 47 cat *Viva!* and I had a very interesting Labor Day weekend. We were anchored at Isla Muertos, which is across the Gulf

**The tip of the Puntarenas peninsula. It rains 24 days a month here in September and October, dropping an average of 11 inches a month!**



of Nicoya from Puntarenas in Costa Rica. We'd been here 12 years before — both with our previous boats — so we were kinda excited to check out the Luminosa Resort.

In the 'old days', the resort was just a big building with a bar where I'd gotten my picture taken with Pancho the monkey. Times have changed. Pancho is gone, having lost an altercation with dogs. Sven, Luminosa's old manager, has been replaced by an Italian couple. And the Luminosa Resort is empty — so empty they only had one beer in stock. After we drank that and some wine, Bob and I headed back to our boats.

That places 'aren't what they used to be' seems to be the norm as Bob and I retrace our paths through Central America from a dozen years before. But there is one constant — theft.

My dinghy was stolen the second night we were anchored off the Luminosa. As many *Latitude* readers know, the bad guys all over Latin America steal the dinghies for the outboard motors they can use on their *cayucas*, *pangas*, *lanchas*, or whatever they want to call them. You never see a Latino driving an inflatable dinghy. Nonetheless, these poorer than dirt people all have \$2,000+plus Yamaha outboards for their *pangas*. Go figure.

Bob and I hoist our dinghies in the davits every night, making it very unlikely that they can be stolen. We never trail our dinghies behind our boat because it would be just too easy for thieves to cut the lines, and drift away with them. After this they would take the motor off and either hide the inflatable in the mangroves or set it adrift.

For the past dozen years, I have religiously hoisted my dinghy at night, both to prevent theft, and to have it secured in case bad weather hits and I have to quickly bail out of an anchorage. A rare exception to the rule is for me to remove the motor, put it on the rail of the big boat, and let the dinghy trail astern. After all, if there is no outboard on the inflatable, there is no reason for a Latino to steal it, right?

So, the *one* time that I make the rare exception — I had put my outboard on the rail of the big boat in Panama's Perlas Islands because I was starting an open ocean trip, and the extra 80



pounds tends to make the dinghy bang around in rough weather — my inflatable gets stolen. I discovered it was gone at midnight. When I pulled in the line, sure enough, it had been cut with a knife. So I was dinghy-less!

Bob wasn't having such good luck either, as his anchor windlass quit working. We had a good idea why, but needed a real electrician to repair it.

So it was that at 4:30 a.m., Bob and I assaulted the beach in his dinghy, and walked up to the bus stop to catch the 5:15 a.m. bus to Paquera and the ferry. When we got to the bus stop, we found out that the bus leaves 15 minutes *before* 5 a.m., not *after* 5 a.m. Something had been lost in the translation when we asked about the ferry schedule. But there was a lady at the bus stop waiting for a ride in a car, and we managed to tag along with her, thus making the 6 a.m. ferry to Puntarenas after all.

We went to the Costa Rica YC looking for an electrician and possibly a dinghy,

Happy Jack



# IN LATITUDES



ANDREW VIK

***New to cruising and unsure how to tell if a yacht belongs to a 1%er? There are two common 'tells'. First, is the staysail roller furler bigger around than the foredeck man? Second, are the yacht's anchors big enough to be used on an aircraft carrier? Solid gold anchors are just for show.***

but we found that our old friend Carlos, the club manager was gone. Fortunately, the hotel manager, a sweet young thing who speaks perfect English, rounded up an electrician who thought he might have a friend who might have another friend with a dinghy for sale.

While sitting at a table in the yacht club at about 8:45 a.m., the girl suddenly said, "Earthquake — oh my God!" There was indeed a little shaking, followed very quickly by some major shaking. Glass was breaking, planters were falling over, and about a quarter of the water in the swimming pool sloshed out. We ducked under a table until things settled down, then got the hell out of the building.

As it turned out, there was no major damage in Puntarenas other than the power and cell phone service going out. But the main highway from Puntarenas north was jammed with traffic, as people

fled the threat of a tsunami — which didn't materialize. Steve and I took a taxi downtown looking for a dinghy dealer, but thanks to the earthquake, every store was shuttered.

The only place that was open was the Bar Porton Verde, which we had frequented when we were here years before. So we went in and drank beer in the semi-darkness for an hour or so, then went back out to the yacht club to check out the dinghy possibility — which turned out to be a bust. So we took the ferry back to Paquera, made a strategic beach withdrawal in Bob's dinghy, and got ready to attack our problems the next day.

My next move was to try to call Apex, the Costa Rican-based inflatable manufacturer who had made my

stolen dinghy. After lots of busy signals that were the result of earthquake damage, I got through to them. Alas, they wanted \$4,000 for the new dinghy — way more than I'd paid for the old one in Panama years before. Plus, there was no easy way to get one to me. So I guess I'll just have to have the folks at Barillas in El Salvador order one for me and pay whatever it costs. After that, I'll hoist it every night!

Bob has been luckier, as he now has two functioning windlasses.

*Update:* Bob and I are now at Barillas Resort in El Salvador, where *Sun Runner* is the only other boat here besides *Viva!* and *Witch of Endor*. When we were here 11 years ago, there must have been 30 or 40 boats. Of course, it is late summer, the lowest of the low season, when it rains like crazy.

Barillas is still just perfect in that it's very un-Central American like — which means that the employees are friendly and actually understand that we are paying guests. Management, in the personage of Heriberto Pineda, is very accommodating, and assists with boats checking into the country.

My message to everyone coming this way is obvious — always lift your dinghy out of the water at night!

— steve 09/15/12

## **Larrikin — Catalina 42 Verdo and Gabriella Verdon Summer In The Sea (Queensland, Australia)**

***Verdo and Gabby as seen at the Encinal YC in Alameda prior to heading down to Mexico last winter aboard 'Larrikin'.***



LATITUDE/RICHARD

***A cruiser without a dinghy is like an ocean without water.***



# CHANGES

"To be or not to be," that was the question for Hamlet. "To spend a whole year cruising Mexico so we can see the Sea of Cortez, or take off across the Pacific in the spring without seeing it," that is the question for many cruisers.

Verdo and Gabriella, Doña de Mallorca's friends from her days working on big yachts in the Med, who sold their home in Queensland to come to California to buy a cruising boat, faced the 'Sea of Cortez Question' last spring. While Verdo and Gabby can't wait to return to the remote islands of the South Pacific, they decided, after a winter on the mainland, that they couldn't just pass the Sea by. So they spent the summer there.

"We absolutely loved it!" gushed an enthusiastic Gabby. "The Sea of Cortez has spectacular geological formations you don't see anywhere else, so my biggest disappointment was not being able to find a proper geology book about it. But the colors, the formations — I wanted to learn all about it."

Not the types who need a crowd of people to be happy, Verdo and Gabby were surprised — and pleased — to feel as though they almost had the Sea to themselves. "We hardly saw a soul," says Verdo, "it was just wonderful."

"We had all the anchorages we wanted to ourselves," confirms Gabby, "but we met some really lovely people, too. I'm in love with the people of Mexico! They are truly the salt of the earth."

Verdo is a fishing maniac, so he had

**Mulege, a town of 3,500 on the banks of the Santa Rosalia River, is about the greenest spot on Baja. It's also home to the 'barless' prison.**

a fabulous time spearing *pargo*, rock cod and lots of other fish. "It was easy," says Verdo. "On the other hand, the Sea is not like it was when I was here 14 years ago. Back then it was magic trolling for dorado. The big sardine boats have come in and taken everything, so in that respect it's been a catastrophe."

One of the things that surprised the couple was how long it took for the water to warm and clear after the winter cold. "When we first got to the Sea the water was too murky to see much, and it was cold," remembers Verdo. "It wasn't until the beginning of July that the water got warm. But it turned warm overnight, and when it did, it suddenly became very clear, too."

The Verdots naturally knew all about the famous summer heat of the Sea of Cortez, but were nonetheless stunned by the reality of it.

"We've been at the equator, Panama, Singapore, and many of the other hot and steamy places in the world," says Gabby, "but we had no idea about the August and September heat in the Sea. It was so stinking hot — over 100 degrees every day! The focus of each day in those two months became finding a place with air-conditioning."

"We had lots of shade for our boat, and slept outside all the time, but still weren't prepared for it," admits Verdo. "Fortunately, we were able to buy an air conditioner from another cruiser for 400 pesos — less than \$40 — and it worked a treat. We could only use it when tied up to a marina, of course, but that's where you really needed it, because when you're on the hook there is usually a little breeze."

Had the Verdots to do it again, they would do the Sea a little differently. "It's foolish to stay on your boat for the most brutal heat of August and September," says Verdo. "The people who have spent a lot of time in the Sea all head back to the States or cooler places during those two months, and with good reason."

The other downside of the Sea in the summer are the *chubascos* and *elephantas*, which are the unpredictable, powerful, but usually short-lived nighttime storms.

"We eventually got tired of the 35-knot and 40-knot storms almost

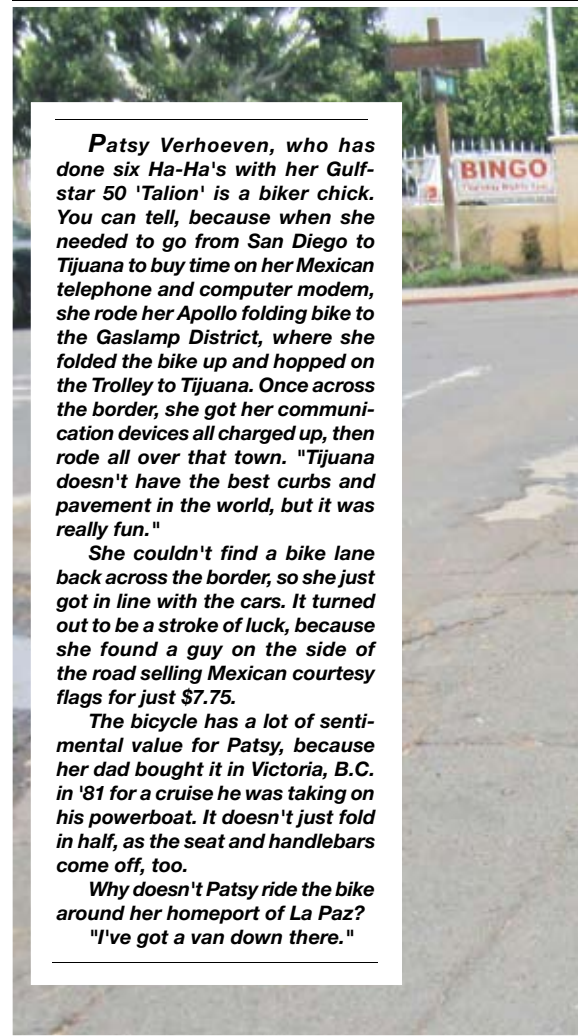

**Patsy Verhoeven, who has done six Ha-Ha's with her Gulfstar 50 'Talion' is a biker chick. You can tell, because when she needed to go from San Diego to Tijuana to buy time on her Mexican telephone and computer modem, she rode her Apollo folding bike to the Gaslamp District, where she folded the bike up and hopped on the Trolley to Tijuana. Once across the border, she got her communication devices all charged up, then rode all over that town. "Tijuana doesn't have the best curbs and pavement in the world, but it was really fun."**

**She couldn't find a bike lane back across the border, so she just got in line with the cars. It turned out to be a stroke of luck, because she found a guy on the side of the road selling Mexican courtesy flags for just \$7.75.**

**The bicycle has a lot of sentimental value for Patsy, because her dad bought it in Victoria, B.C. in '81 for a cruise he was taking on his powerboat. It doesn't just fold in half, as the seat and handlebars come off, too.**

**Why doesn't Patsy ride the bike around her homeport of La Paz? "I've got a van down there."**

every night when we were at Bahia de Los Angeles, so we headed over to San Carlos on the mainland," says Verdo. "We only paid \$16/night at San Carlos Marina, and that included water — and the electricity for our air-conditioner. With the marina water temperature 91 degrees, you can imagine how hot the still air was."

When we spoke to the couple at the beginning of October, they were excited to be heading off on a trip to the Copper Canyon, and noted that the summer heat in the Sea had finally broken. "The southerlies of summer have been replaced by winds out of the northwest" said Verdo. "By the time we get back from the Copper Canyon, the cruising weather should be ideal."

Barring late-season tropical storms, many Sea vets consider October to be the best weather month for cruising. The water is still warm and clear, the daytime highs are high 80s to low 90s, and the nighttime lows are a positively chilly 70 degrees or so.



**Gabby with the catch.**

**Mulege, a town of 3,500 on the banks of the Santa Rosalia River, is about the greenest spot on Baja. It's also home to the 'barless' prison.**



LARRIKIN

LARRIKIN

# IN LATITUDES



LATITUDE/RICHARD

It's one of the perversities of human nature to take what is easily accessible for granted. So many of us on the West Coast lust for what's in the distant South Pacific or Southeast Asia, when we have unique cruising treasures such as the Sea so close to home.

"Verdo and I are not the only ones who loved the Sea," says Gabby. "We had some Kiwi friends — true world travelers — who spent two weeks cruising with us. They were in awe of the Sea of Cortez, having not had any idea what a spectacular and unique place they were coming to. In fact, they told us it was one of their best holidays ever."

We didn't ask, but we assume the Kiwi couple didn't visit in August or September.

— latitude/rs

**Harmony — Islander Freeport 41  
Robert and Virginia Gleser  
Hurricane Paul  
(Alameda)**

Mother Nature always seems to find

new ways to test us. As far as storms go, mid-October's hurricane *Paul* was not the strongest or longest lasting *tempesta* to hit the Sea of Cortez. But for us, it brought a day to remember.

We want to thank everyone who called all the many gods of weather on our behalf, because although *Paul* passed close by, he showed us mercy. We were particularly fortunate in that we had no thunder or lightning in our neighborhood — which for the duration of the storm was Santa Barbara Cove, Concepcion Bay, which is about 220 miles NW of La Paz and 80 miles NW of Puerto Escondido.

We had wind from all directions, but much of the day we were bucking into wind out of the north — the one direction for which Concepcion Bay affords no protection. It was nonetheless the place to be, as we knew that the stronger winds

would come from the south, meaning we'd eventually have great protection from seas.

Sure enough, the wind direction suddenly switched from north to south in the middle of the afternoon. All seven of the other boats in the anchorage with us quickly turned on their hooks to face the new direction. The wind then gusted to close to 60 knots, just shy of hurricane strength.

And then the rain started pouring down. We opened the water tank fill and let the rainwater flow in until the tank was full. We also collected water in bowls and a five-gallon bucket so we could rinse our hair. But then a strong gust hit, knocking the full bucket over, dumping water into the cockpit. Doh!

The wind blew a sustained 25 to 30 knots for about 20 hours, with regular gusts to 40 knots, and a couple to 50. Thanks to the never-ending torrents of rain, we found all of *Harmony's* leaks, which our normal dry season cruising allows us to ignore. But with eight inches of rain in just 12 hours, we were scampering around looking for towels to catch the leaks, then having to wring the towels out. There wasn't any permanent damage, but we can't ignore those leaks any longer.

The eight inches of rain in the afternoon created gullywashers. By midday, the usually blue-green water of the bay was mixed with muddy swirls of water littered with cactus and other debris from land. It was an eerie sight.

Fortunately, there wasn't any damage to the boats anchored with us. One boat had the dinghy with the outboard in the water and tied to the side of the boat. Before long, the dinghy was airborne, then landed upside down, soaking the motor. The local mechanics stopped by the next morning to flush the engine out.

***Hurricane in stereo. Paul heading up toward Baja, and Rafael having left the Eastern Caribbean. Neither caused much damage.***



STORM CENTRAL

# CHANGES

They had it running again in no time.

A boat in a nearby anchorage was in shallow water when the new moon tide reached its lowest point, and went aground. He was able to kedge off in the rising tide. We heard that one boat in San Carlos broke free from her mooring and landed on the beach, but compared to previous tropical storms and hurricanes that have come up the Sea, there was apparently little damage.

Since one of our dodger window covers had blown off during the height of the storm, the next morning we borrowed Ben, 6, and Huon, 3, the two little Tasmanian kids off the catamaran *Sonrisa*, and took them treasure hunting on the beach. We didn't find our dodger cover, but we did find lots of shell treasures, sticks, and mud holes to splash in. After that we brought the kids back to play with Rob's gun collection. Fun times!

So *Paul* turned out to be about what it had been forecast to be. Had stronger winds been predicted, we might have run to a real hurricane hole, or maybe a marina. That said, a buddy who was in the Santa Rosalia Marina just north of us said he had to bail out at 2 a.m. because the docks were disintegrating.

The good news is that all the fuss is already over, and the bands of clouds are getting thinner while the strips of blue between them are getting larger. Our solar panels are pumping juice again after three days of nothing. In addition, the bay water is already clear again, and the desert is a lush, verdant green, with butterflies — and probably some biting bugs — multiplying by the minute. Since the weather files suggest that this would be a fine time to head south toward La Paz, we'll soon be on our way. With any luck, *Paul* will have been the last tropical weather threat of the season.

— robert and virginia 10/18/12

**Heavy rain in desert terrain results in flash flooding. Puerto Escondido got 10 inches from tropical storm 'Paul' in one day. Look out!**



*Readers — Paul came ashore as a Category 2 hurricane at Mag Bay on the Pacific Coast 160 miles north of Cabo San Lucas, but quickly began to lose power over land. La Paz, 90 miles to the ESE in the Sea, had lots of rain but no wind. Puerto Escondido, 120 miles to the north, had 10 inches of rain and 30 knots of wind. David Eidell reports that Asunston Bay, 50 miles southeast of Turtle Bay approximately halfway down the Pacific Coast of Baja, had 40 knots of sustained wind but no damage.*

### Cruise Notes:

"That was a nice photo *Latitude* recently ran of some cruisers holding up clams they'd taken in the Sea of Cortez, but it might be a nice idea to remind everyone that it is illegal for non-Mexican citizens to take any shellfish," writes James Hassberger of the La Paz-based Valiant 40 **Kanga**. "I know of one cruiser who had his dinghy, outboard and fishing gear confiscated — fortunately only temporarily — but had to pay several hundred dollars in fines, and had to travel all the way from Loreto to La Paz to get it straightened out."

Hassberger is correct, and we apologize for the massive brain fade on our part. We knew full well that it's illegal for foreigners to take **shellfish** in Mexico, we just somehow figured that anything smaller than lobster really didn't qualify as shellfish. Idiots! A complication, of course, is that from time immemorial some Mexican fishermen have offered to sell cruisers shellfish — almost always lobster. Once again, that's not only illegal, it violates the rules of the cooperatives that most of them belong to.

We're shedding buckets of crocodile tears for **Ahmed Muse Salad, Abukar Osman Beyle** and **Shani Nurani Shiekh Abrar**, the three Somali pirates who have been charged with the February '11 hijacking of the Marina del Rey-based Davidson 59-ft **Quest**, and the subsequent murders of Jean and Scott Adam of Marina del Rey, and their crew, Bob Riggle and Phyllis Macay of Seattle. Attorneys for the three Somalis are challenging the fact that 22 of the 26 charges they are facing are "death penalty-eligible". Their attorneys, paid for by you and us, argue that the death penalty is unconsti-



tutional because, among other things, it's "cruel and unusual punishment". Perhaps their attorneys would also like to argue that the cold-blooded murders of four innocent cruisers was somehow 'kind and common behavior'.

In related news, **Somali pirate attacks** have dropped in the last year. Forty-six vessels were hijacked in '09, 47 in '10, but only 25 in '11. According to an Associated Press report from Hoby, Somalia, business has been so bad for the less-than-devout Muslim pirates that whiskey consumption is way down, and prostitutes — well-known for their 'no cash, no splash' policies — are being asked to provide their services on credit. Despite the sharp drop in hijackings, we doubt that traffic on the one-time cruiser freeway from Thailand to the Med, via the Indian Ocean and Red Sea, is going to pick up anytime soon.

"My goal is to be the first person to circumnavigate with a San Juan 24 sailboat," advises 61-year-old Rimas Me-

# IN LATITUDES

Our most recent visit was as participants in the Southwestern YC's 62-mile **Little Ensenada Race** from San Diego to Ensenada.

While we managed to complete only 61 of the 62 miles before the wind shut down completely in the early hours, we still had a blast. The sailing was even better on the 16-mile around **Todos Santos Island Race** two days later.

While downtown Ensenada could hardly be described as posh, it's lively after dark, and the locals are as friendly as anywhere in Mexico — and that's saying something. Thanks to **Cruiseport Marina** and the **Coral Hotel & Marina**, the berthing options are clean and secure. The fact that mariners have to check in to Mexico and get a tourist visa is, of course, an impediment to visits by California sailors. However, Mayor Enrique Pelayo told us that he and some legislators are looking to get this changed.

The other thing that impressed us were the veteran cruisers who have decided to base out of Ensenada rather than California, and not because it's less expensive — diesel was just \$3/gallon — but because they like Ensenada more. Among them are longtime cruisers Jan and Ramona Miller, who three years ago returned to the West Coast after a long trip across the Pacific with their Odyssey 30 **Jatimo**. As much as they liked their old homeport of Santa Cruz, they like Ensenada better. Another couple

After their long cruise across the Pacific, Ramona and Jan of 'Jatimo' find that they prefer Ensenada over any bases in California.



Darah Basham's ancient Ericson 35 'Cimarron' rocked in both races.

LATITUDE/RICHARD



Ensenada fun, from above. Local boat 'Bajavento' shows the way to Todos Santos. Hotel San Nicholas, party H.Q. Irene and Lionel of 'Kiapa' and Perth. Pharmacies are everywhere. Sano's steak, best around. Hussong's and the taqueria next door. 'Loreal'. John P. has Corona Beer girl trouble!

leshyus of the Port Townsend, WA-based **Cesura**. Born on the shores of the Black Sea in Russia, Meleshyus is used to taking calculated risks. "I escaped the Soviet Union in '88 by fleeing to the American Embassy in Moscow and claiming political asylum. I have lived in many places in the world since then, but have resided in the United States for quite a few years — and will thus be proudly sailing under the American flag."

Apparently a bit of a nautical masochist, Meleshyus plans to depart Port Townsend in May on the gloomy 5,270-mile upwind and upcurrent sail to Japan on his 24-ft *Cesura*. We can't think of why he's starting by sailing to Japan, except for the fact the's fluent in Japanese. Anyway, from Japan he'll sail to Guam, Cape Horn, St. Helena, South Africa, Thailand, Vanuatu, Guam again, and finally back to Port Townsend. "It

takes a high degree of self-sufficiency and physical fitness to do such a circumnavigation, and I have both," says Meleshyus, who is supremely confident despite, if we're not mistaken, having lost his first San Juan 24.

We wish the proud Russian-American a safe and successful voyage. It will be interesting to see how his attempted circumnavigation compares with that of Webb Chiles — see this month's *Sightings* — who is hoping to complete his sixth circumnavigation, this time aboard his Moore 24 **Gannett**.

Having visited **Ensenada** twice in the last four months, we're here to tell you that the fishing port 62 miles south of San Diego has been overlooked by cruisers in recent years.



LATITUDE/RICHARD

# CHANGES

who think Ensenada is just great are Lionel and Irene Bass of Perth, Western Australia. A little more than a year ago the couple purchased Pete and Susan Wolcott's M&M 52 catamaran **Kiapa**. They plan to take three years to sail and surf her across the Pacific to Perth.

"It was great to read about and see photos of Ensenada, as well as both the 'new' and 'old' Hussong's Cantinas," write Jim and Robbie Hill of the Peninsula and Sayulita, Mexico, former owners of the Farr/Tompkins 55 **Amazing Grace**. "After finishing the Big Ensenada Race in about '54, some friends and I went to Hussong's Cantina. As we were sitting there, two guys on a rented horse rode in. They ordered three margaritas. "One is for the horse," they explained. They had no problem getting served.

We don't know if you can still ride horses into Hussong's, but paying a visit to Hussong's on their wedding day is still a tradition for many Ensenada brides.

"I am still in Palau, but leaving in October for Puerto Galera in the Philippines in order to participate in the **Royal Cargo All Souls Regatta**," reports David Addleman of the Monterey-based Santa Cruz



David Addleman's many friends from his years cruising his Cal 36 'Eupsychia' in Mexico will be glad to know he has a new girlfriend, Shayne.

50 X. "The regatta sponsors claim their regatta is 'the most fun in the world', and sailed on 'the most beautiful bay in the world'. I don't speak Tagalog, so it's a good thing Shayne, my liveaboard

girlfriend, is Filipina."

We'd never heard of the All Souls Regatta, which is held November 2-4, but based on our research and knowing how much Filipinos love fun, it's sounds like a blast. The event was founded in '04, and at least 30 boats are expected to participate this year, from small boats, to cruising boats, to multihulls, to IRC boats. Event organizers emphasize that everyone is encouraged to participate, no matter what kind of boat they have — or even if they don't have a boat at all.

Norm Sween is hoping that someone gives him the finger when he, his wife Susan, and crew Justin and Erika Sween of Bodega Bay arrive in Fatu Hiva in the Marquesas with their 32-ft cutter **Monte Cristo** in the summer of '14. "I first ventured to the South Pacific in '93 aboard the same 32-ft cutter, which was named **Monte Crest** back then," says Norm. "By accident, I left my right index finger in a plastic bottle at Hana Vatu on Fatu Hiva as a 'gift to the gods'. I later heard from a French vessel in Bora Bora that my finger had been found, but spirits would keep it there until I returned. If anyone else

## Ready to be surprised?

If you haven't visited Ensenada in the last few years, make us your next nautical destination, you will be surprised to find out what our city has to offer!

## Ensenada welcomes the boating community!

Visit Mexico's most important Wine Region; enjoy our magnificent Baja Med Cuisine, live the outdoors and experience a variety of attractions for you and your crew, and a diversity of quality services for your boat: marine chandlery, boat yards, fuel dock, launch ramp, live bait and fully equipped marinas.

Ensenada Log it in.

Contact us: [customerservice@puertoensenada.com.mx](mailto:customerservice@puertoensenada.com.mx)  
[www.puertoensenada.com.mx](http://www.puertoensenada.com.mx)

  PortofEnsenada

Blvd. Teniente Azueta #110, Recinto Portuario, Ensenada, BC, Mexico.



Ensenada Cruiseport Village

has found my finger, please contact me at [norm.swn@gmail.com](mailto:norm.swn@gmail.com)."

"When *Latitude* recently wrote about Mexico, I was surprised that you didn't mention **Barra de Navidad**," writes Capt Adriana Kenlan, with the 'Wonder Poodle' Boxer of the Oceanside-based Catalina 36 **Stimulator**. "Barra, 135 miles south of Puerto Vallarta, is amazing because it's safe and secure, has crystal clear water, is easy to enter, and has every amenity a sailor could ask for. When I needed a hurricane hole for the summer, I discovered Marina Isla Navidad, which turned out to be the best marina in Mexico — and better than most in the world. The marina is connected to the Wyndham Grand Bay Hotel, which is ranked the #1 Mexican Resort by the *Travel Channel*. Marina tenants have access to everything. In addition to 207 new slips with water, electricity, and Internet, there are eight spotless shower rooms, a massive pool with a water slide, bar and food service, a spa, tennis courts, a great golf course, inexpensive restaurants, and magnificent scenery. A French baker even delivers French pastries and bread

every morning by boat. I know my boat is safe because she is guarded 24/7 and maintained by a conscientious staff."

Our neglecting to mention Barra was certainly an oversight — and for more reasons than just the Marina Isla Navidad. As Mexico vets know, the marina is right across from the charming and inexpensive waterfront town of Barra de Navidad, which shares the same small bay as Melaque. It's also right on the shores of the **Barra Lagoon**, where cruisers can anchor securely for free in totally protected waters. The Grand Bay Hotel and the marina are both very nice, but with all due respect, we think it's a stretch to claim that the marina is one of the best in the world and the resort the top-rated one in Mexico. We like them both, but they both have



**The entrance to the very nice and well-protected Grand Bay Marina, with the Wyndham Hotel in back. Charming Barra is across the way.**

plenty of competition.

A woman sailor who owns a boat named *Stimulator*? If we didn't know better, we'd think it was provocative.

How are we supposed to believe anything **Pat** and **Carole MacIntosh** of Roseville tell us? A while back they sold their Hunter, and said they were moving to powerboats. Yet on September 28, they

## Your Boatyard in the Heart of Paradise



*Large, fenced, secure dry storage area*

**Tahiti Customs policy has changed!**  
Foreign Flag vessels can stay on dry storage in our yard for up to 12 months out of 24.



A Subsidiary of  
The Moorings Yacht Charter, Ltd.

### Our Services | HAULOUT

- Marine Travelift 25 tons
- Marine railway 120 tons
- Storage in adjustable steel cradles
- Fenced Yard

### PAINTING

- Topsides, hull, bottom, varnish
- Brush, roller, spray

### MECHANICAL WORK

- Inboard, outboard, diesel, gas
- All brands

### REPAIRS

- Electrical repairs
- Refrigeration installation & repair
- Fiberglass & woodwork
- Welding, steel, stainless, aluminum

### SAIL LOFT

- Sail repairs, biminis, dodgers, covers

### STORE

- International, Pettit, Epiglass, Devoe
- Spares
- Fill U.S. gas cylinders

### DO-IT-YOURSELFERS WELCOME!

*BoatUS Cooperating Marina*



*Professional boatyard in the heart of Paradise*

*Raiatea Carenage will make sure paradise is everything you expected. Call, write, or sail in . . . we're here to serve you.*

**B.P. 1111 Uturoa Raiatea 98 735 Polynésie Française**

**Tel: (689) 600-545 ~ Fax: (689) 600-546 ~ VHF 68**

**Web site: <http://www.raiatea.com/carenage> ~ email: [raiateacarenage@mail.pf](mailto:raiateacarenage@mail.pf)**

# CHANGES

sent the following email: "We're about to close a deal on a Cheoy Lee 35 in Barra de Navidad — and she is not a project boat."

Jim and Chris Machado of Puerto Vallarta-based Jeanneau 41 **La Ballona** are another cruising couple who have changed boats. "It's the fault of Dave Wegesend of the Puerto Vallarta-based **Maluhia**, who took us sailing on his Catana 42 cat, that we've gone over to the 'dark side'. "We're now the owners of the Catana 43 **Bright Wing**, the only tall-rig 43 ever made." *La Ballona* was brought up from Puerto Vallarta for sale in San Diego, while *Bright Wing*, which was in Alameda, is now in Ensenada. As Jim is recovering from back surgery, he and Chris probably won't sail south for Mexico until December.

As we reported in *'Lectronic* a few weeks ago, **The Div Bar** — at the far west end of Newport Harbor, and which used to be Josh Slocum's Restaurant, and then for a time was owned or fronted by Dennis 'Sexual Chocolate' Rodman — welcomes cruisers to come by and use their dock space to take on water, wash



LATTITUDE/RICHARD

***This dock is for you! If you're a southbound cruiser needing a place to park your boat for a few hours in the morning so you can shop.***

their boats, and tie up to go shopping. But — and it's a 'but' as big as Kim K's — the docks have to be cleared by noon to let paying restaurant customers use the space. The Div Bar is easy to find. Just look for circumnavigator Ernie Min-

ney's DownEast 38 **Anita**, "named after my fourth wife." Much more than a bar, the Div Bar is a great smokehouse, too. Even more important to frugal cruisers, it's only a moderate walk from inimitable Ernie's **Minney's Marine Surplus** on Newport Blvd. It's the biggest marine surplus store on the coast, and is loaded with bargains..

You're on an **Air Canada** flight from Vancouver, British Columbia, across the Pacific Ocean to Sydney, Australia, on a Boeing 777 on October 17. When the plane descends from 24,000 feet to 5,000 feet, you're not too worried, because you're 12 hours into the flight and figure you must be getting close to landing. But then the captain asks if any of the passengers has a pair of binoculars he can borrow. Wha?!?! Actually, there wasn't any reason for the 270 passengers aboard flight AC033 to freak, because the captain was just responding to an Australian Maritime Safety Authority request to search for the source of an EPIRB signal. In fact, the captain asked the passengers to look out the windows for a dismayed vessel. When a



**SARANA GUIDES**  
For Central America

"...[these] thoroughly researched books are now the undisputed cruising guides for the Pacific coasts of Central America." -- Jimmy Cornell

Get your copy today:  
[www.svsarana.com/guide](http://www.svsarana.com/guide)



**1,000 Used Sails**  
Listed at  
[minneysyachtsurplus.com](http://minneysyachtsurplus.com)

**We Buy Good Used Sails and Marine Equipment**

**MINNEY'S YACHT SURPLUS**  
1500 Newport Bl., Costa Mesa, CA  
949-548-4192 • [minneys@aol.com](mailto:minneys@aol.com)  
"We keep boating affordable!"



**ULI**

INFLATABLE SUPS  
**ULIBOARDS.COM**  
760.639.1844  
VISTA, CA

**KATADYN SURVIVOR 35 WATERMAKER**

The Survivor is a must for all sea-going vessels and is the most widely used emergency desalinator. It is used by the U.S. and international forces. It is able to produce 4.5 liters of drinkable water per hour.

Reconditioned by Katadyn **\$950**  
Compare to factory new price: \$1,995

For more information or to place an order, please contact one of our sales reps.



**Equipment Parts Sales**  
In the U.S.: (800) 417-2279  
Outside the U.S.: (717) 896-9110  
email: [rod@equipmentpartssales.com](mailto:rod@equipmentpartssales.com)



passenger with a pair of binos did spot the vessel, a big cheer went up from the other passengers. The distressed vessel's singlehanded skipper had left Sydney for New Zealand two weeks before, had been dismasted, and ran out of fuel 300 miles east of the Australian coast — i.e. in the middle of nowhere. He and his boat were later rescued by Australian resources.

As reported several times in *Lectronic*, **Mexican Immigration laws have changed**, with potentially major ramifications for cruisers. According to the letter of the new laws, boats arriving in Mexico have to electronically notify officials at their port of entry 24 hours before they arrive; will have to be inspected at their port of entry; and will not be permitted to stop anywhere in Mexico prior to clearing in at a port of entry. In other words, if you don't clear in at Ensenada, you can't stop anywhere along the coast of Baja until you check-in at Cabo San Lucas. At first glance, it may seem as if Ensenada is making a grab for Immigration and business income. But when you think about it, what other country would allow you to leisurely

cruise 750 miles of their coast before clearing in?

Nonetheless, the new rules had the potential to create problems for this year's Ha-Ha, because Ensenada doesn't currently have the facilities or manpower to handle 150 boats arriving at once. Fortunately, **Neil Shroyer** of Marina del La Paz, **Fito Espinoza** of Coral Marina, and other members of the Mexican Marina Owners Association, were able to work with Immigration officials in Mexico City to delay implementation of the new rules until November 9, the day after all the Ha-Ha boats should have cleared in at Cabo San Lucas. In addition, implementation of the other rules will be "gradual". This is out of necessity, because immigration and port captain offices are not equipped to handle the new procedures. Given that there will be a whole new federal government taking over on December 1, and the current impracticability



*The Hotel Coral's swimming pools and hot tubs were just the thing after both the Little Ensenada Race and the Todos Santos Race.*

of the new rules, it's possible that some or all of them will be rescinded.

The bottom line is that if you're heading south after the Ha-Ha, and you want to be in accordance with Mexican law, you'll need to **clear into Mexico at Ensenada** — at least if you want to stop anywhere along the coast of Baja before Cabo San Lucas. Shroyer also recommends getting your Temporary Import Permit online, although you probably



**Mast Mate™**

Climb Your Mast Alone with Mast Mate  
Made in the USA for 20 Years

**Satisfaction Guaranteed**

**(207) 596-0495**  
**www.mastmate.com**



**KISS-SSB**

The Simple, Proven  
Marine SSB  
Ground Plane



• Easy to install  
• Superior performance  
• Fiberglass/wood boats  
• Sail or power

See  
**www.kiss-ssb.com**  
for more info or to order.

**(360) 510-7885**

"I would sail away  
in the shallop of  
your heart"

— Paolo  
Conte



**STARBUCK CANVAS WORKS**  
**415•332•2509**  
67 Liberty Ship Way, Sausalito, CA 94965



**WIRELESS E-MAIL**

ICOM



SCS  
the pactor creators

**SEATECH SYSTEMS™**  
800.444.2581 • 281.334.1174  
info@sea-tech.com • www.sea-tech.com

**Navigation, Communication & Weather**

# CHANGES

need to allow two weeks to get it. We'll keep you posted on how the situation evolves.

What's up for cruisers in Mexico this winter? Here are some of the major events:

**November 20** — Multi-sponsor **Welcome to La Paz Ha-Ha Party** and festivities. Everyone welcome, but first 50 Ha-Ha participants get in free.

**November 22** — **Thanksgiving** celebrations everywhere cruisers gather. It's always been big in Mazatlan.

**December 12** — **Nayarit Riviera Sailor's Splash**, Paradise Marina in Nuevo Vallarta, the Marina Riviera Nayarit in La Cruz, and a bunch of local restaurants welcome members of the Ha-Ha fleet — and everyone else. Free.

**December 13-15** — **Banderas Bay Blast**, 'nothing serious' cruiser racing between Paradise Marina, Riviera Nayarit, and Punta Mita, also including the **Swimming Pool Volleyball Championships**, the opening of the **Punta Mita Yacht & Surf Club**, and the **Pirates for Pupils Spinnaker Run for Charity** on the 15th. Free except for \$1 yacht club



LATTITUDE/RICHARD

*The Banderas Bay Blast 'water balloon drop'. There is more much than sailing to the various cruiser events in Mexico.*

membership. Free berthing for one night at both marinas.

**December 25 and January 1** — Holiday celebrations everywhere cruisers gather.

**February 7-12** — **Zihua SailFest.**

For years this has been the biggest cruiser-led fundraiser in Mexico, all for local schools. But it counts on a new group of cruiser volunteers each year. Great fun, terrific cause!

**March 19-23** — **Banderas Bay Regatta**. While still 'nothing serious' racing fun for cruisers, this is the biggest one of the season in Mexico, and the Paradise Marina / Vallarta YC venue is world class for fun. Free.

**April 12-15** — **Club Cruceros de La Paz Bay Fest**. All kinds of sailing and social fun to kick off the season in the Sea of Cortez. Free.

**May 4-6** — **Loreto Fest**, Puerto Escondido. The biggest cruiser gathering in the Sea of Cortez, with lots of music, seminars, and fun. Free, but also a fund raiser for local schools.

There are lots of other smaller events in Mexico over the winter that are great fun, too. Tune into your local VHF nets for further information.

With **another cruising season upon us**, we wish everyone safe sailing! Don't forget to write — short and sweet is perfect — or send in the high res photos.

## The Challenge:

# Grow Yacht Club Membership

Oakland Yacht Club says thanks!

**"We are getting great results from these ads, as many of our new members have smaller boats. They report they found out about our special by seeing it in *Latitude*. Advertising works! Especially for the hard to fill small slips. Our harbor is now nearly full, and for the first time in 11 years, we are on track to finish the year with more members than we started with."**

**— Allan Haddad, OYC Member  
Phil Helman, Membership Chair**



*Latitude 38* says thanks too. Our fabulous readers benefit from the support of great advertisers like OYC.

*Latitude 38*

[www.oaklandyachtclub.net](http://www.oaklandyachtclub.net)

[www.latitude38.com](http://www.latitude38.com)

# El Salvador

A hidden treasure. Share it!

  [www.elsalvador.travel](http://www.elsalvador.travel)

  
**El Salvador**  
Impressive!



Come and have a great time in  
El Salvador Fourth Annual Cruisers Rally  
Next March 16th to April 20th, 2013  
[www.elsalvadorrally.com](http://www.elsalvadorrally.com)

Please read before submitting ad

# Classy CLASSIFIEDS

## Here's What To Do:

**Write your ad.** Indicate category. Remember price and contact info. We make final placement determination.

**Count the words.** Anything with a space before and after counts as one word. We will spell-check, abbreviate, edit, as necessary.

**Mail your ad** with check or money order, deliver to our office; **OR, for the best - and most exposure - of your classified ad...**

**Submit your ad safely online** with Visa, MasterCard or AmEx at: **www.latitude38.com**

Ad will be posted online within two business days, appear in the next issue of the magazine, and remain online until the following issue is released.

## PERSONAL ADS

1-40 Words.....\$40  
41-80 Words.....\$65  
81-120 Words....\$90  
Photo.....\$30

• Personal Advertising Only •  
No business or promo ads except Non-Profit, Job Op, Business Op

**'Trying to Locate' Ads** are for those searching for lost boats/people - not shopping - and cost **\$10 for 20 words max**

**FREE Online Ads** are for a private party selling a boat for less than \$1,000 - or gear totalling under \$1,000. (One per person; must list prices in ad.)

All ads will be set to fit *Latitude 38* standard • Re-Run Ads: Same price, same deadline

## BUSINESS ADS

**\$70 for 40 Words Max**

• All promotional advertising •  
1 boat per broker per issue  
Logo OK, but no photos/reversals  
No extra bold type • Max: 12 pt font  
Artwork subject to editor approval.  
Biz ads will not appear on website.

## DEADLINE

is **ALWAYS** the **18th at 5 pm**

for ad to appear in the next issue.

*Due to our short lead time, deadlines are very strict and include weekends & holidays.*

**Sorry, but...**

- No ads accepted by phone
- No ads without payments
- No billing arrangements
- No verification of receipt
- We reserve the right to refuse poor quality photos or illegible ads.

*Latitude 38* 15 Locust Ave, Mill Valley, CA 94941 Questions? (415) 383-8200, ext 104 • class@latitude38.com

**WHAT'S IN A DEADLINE?** Our Classified Deadline has always been the 18th of the month, and it's still pretty much a brick wall if you want to get your ad into the magazine. But it's not so important anymore when it comes to getting exposure for your ad. With our new system, your ad gets posted to our website within a day or so of submission. Then it appears in the next issue of the magazine. So you're much better off if you submit or renew your ad early in the month. That way your ad begins to work for you immediately. There's no reason to wait for the last minute.

**16-FT DRASCOMBE DABBER, 1985.** Santa Cruz, CA. \$2,500. Classic lapstrake hull, cedar spars, lug rig (gaff), mizzen, yawl, red sails, teak, outboard motor well, beachable, made in UK. Trailer. See specs at website. www.honnormarine.co.uk. Contact Bob at: (831) 662-0604 or (408) 461-0001 or wingman9@comcast.net.



**24-FT NOR'STAR FLICKA, 1976.** Berkeley, CA. \$14,000. *Visions*, 1GM10 Yanmar diesel, furling, lines led aft, dodger, boom gallows, shore power, depth sounder, VHS, CQR, storm cockpit, large stern locker, extra sails. http://photos.glenksteiner.com/visions. (415) 459-2001 or glenn@greekislandphotography.com.

**23-FT COLUMBIA "T", 1973.** \$3,000. Shoal draft, roller furling, well maintained. Cockpit and interior cushions. Bilge pump, air vent fan. Ready for bottom paint. Exterior woodwork recently refinished. Dual axle trailer. Clean inside and out. Request photos. (707) 499-9396 or alpsail@gmail.com.

**15-FT WESTCOMAR SLOOP, 1968.** \$950. 15-ft sailboat with trailer. Brand new sails. (530) 410-1199.



**21-FT WILDERNESS, 1980.** Brickyard Cove Marina (Dry Storage). \$3,900/obo. Fresh water boat, KKML refit 8/2012. New standing rigging, faired, barrier and bottom paint, Harken traveler, custom mast base/organizer, wood refinished, VHF antenna, new electrical, fittings rebbed and G10 backed, new stanchions and lifelines. Two spinnakers and pole, three jibs, main with reefs. Trailer new disc brakes/actuator and electrical. http://tinyurl.com/Wilderness21. Contact (775) 742-0078, (775) 829-8964 or JohnAMcDonald@Gmail.com.

**J/24, 1980.** Point Richmond, CA. \$5,000/obo. Overall good condition. Fun and fast boat. Mainsail, jib, storm jib, 2 spinnakers, spinnaker pole, Nissan 4-hp outboard. Bottom painted a year ago, cleaned quarterly. Photo available by email: broadside.je@gmail.com.



**ULTIMATE 24, 2003.** RYC. \$39,000. *Vuja De*, Hull #8, sail #28978. Always dry sailed, never chartered. 2003 (U-24's named sportboat of the year in 2003). 18+ kt. Boat. Includes: trailer, 2 mains (Kevlar, Dacron), 2 jibs (Kevlar, Pentex), 2 Airex spins, 2 nylon spins, Tacktick, 3.5hp 4-stroke Mercury, VHF, MOB pole, Lifesling, EPIRB. Autohelm extra-\$500. Memorable events: 1st Place: 2003 and 2007 Nationals. 2009 3 Bridge (U-24 class). 2005 Jazz Cup (fastest corrected monohull). 2004 OYRA Lightship. 2003 VYC Brothers. 2004 Pumpkin; 2nd Place: 2003 Pumpkin; 2006 Jazz Cup; 2006 Nationals; 3rd Place: 2004 Nationals (first co-ed crew), 2007 Jazz Cup. 2012 Corinthian midwinters. Also won a bunch of beer cans. Contact (707) 315-9120 or racerxy@hotmail.com.

## 24 FEET & UNDER



**15-FT WEST WIGHT POTTER, 2008.** Alameda. \$7,250/obo. Famously seaworthy microcruiser, lightly used, in excellent condition, and ready to set sail. Premium and bluewater packages, roller furling, running lights, marine battery (1 yr old), solar panel, custom whole boat cover, EZ-Loader trailer, many more extras, optional 2hp outboard (not included in price). (510) 459-6741 or chrism-j@sbcglobal.net.



## WOODRUM MARINE

Specializing in custom interior cabinetry, tables, cabinets, countertops, cabinsoles. For power or sail.

**CARPENTRY**  
Mobile cabinet shop  
Contact Lon Woodrum at:  
**415-420-5970**  
www.woodrummarine.com



## NOR-CAL COMPASS

Adjustment • Sales  
Authorized Compass Repair

Hal McCormack • norcal.compass@verizon.net • Phone/Fax (415) 892-7177

## N.E. MARINE TITLE

Coast Guard documentation • Title/lien searches • Transfers • Mortgage filing • Escrow services  
Local closing facility for brokers or private transactions  
30 years experience of doing it right the first time

1150 Ballena Blvd, Alameda, CA • (510) 521-4925



## MARINE SURVEYS - Capt. Alan Hugenot

Accredited Marine Surveyor (since 2004) • (415) 531-6172  
Yacht Master (USCG 200 tons - International) • Port Engineer  
Yacht Manager • Delivery Skipper • Boat Handling, Navigation  
& Safety Instructor • Accepts MC & VISA



**J/22, 1983.** San Francisco/Monterey. \$13,000/obo. Proven winner, epoxy bottom, dry sailed since 2003, clean interior, kept dry, several sets of sails including Quantum racing set, 2003 Triad trailer great condition, lots of extras. Contact for more info/pictures. Email ggreenlee05@sbcglobal.net.

## 25 TO 28 FEET

**28-FT PEARSON TRITON 28.5, 1965.** Presidio YC. \$2,500. Classic racer/cruiser perfect for Bay and beyond. Major refit '09: Bottom, rudder, topsides. Rigging, cosmetics and interior medium+, but very solid, dry boat. Loads of spare hardware. Atomic 4 good shape. Pictures available. Email challengesea@yahoo.com.

**26-FT BALBOA, \$4,300/OBO.** Tandem trailer, new tires, new bottom, new Mercury 9.9 four-stroke. Health forces sale. let's talk. Call Bill. (209) 371-1877.

**27-FT CS-27, \$18,000.** Canadian Sailcraft 27. New LP, sails, stove. Previous owner spent \$40,000-plus. The prettiest CS-27 on the Bay. Recent haulout. Fast sailer. Feed my cockroaches. (415) 272-5776 or 1944baby@gmail.com.

**28-FT ALERION EXPRESS.** Sausalito. \$70,000 (1/2 of new price). Spinnaker, gennaker, GPS, holding tank, radar, autopilot, all lines led to cockpit, lifelines. "The prettiest girl on the dock." (415) 302-7490.

**25-FT MERIT, 1986.** Morgan Hill. \$8,900 or trailerable trade. New gelcoat, new lifelines, low hour Honda 2hp. 1999 tandem Trail-Rite trailer, just added 5 support posts and pads (11) total no rust. New, never hoisted UK Kevlar jib. Other sails fair. Custom foam cockpit cushions. (408) 842-6511.

**28-FT BRISTOL CHANNEL CUTTER.** 2003. Alameda. \$169,000. Sam L Morse factory-finished layout. All teak exterior. Bronze fittings. 27hp Yanmar. Freehand windvane. MaxProp. Radar, Garmin touchscreen GPS, X-5 autopilot, Icom VHF, EPIRB. Refrigeration. Pressure hot and cold water. More info at [www.leoregus.org/Adventure.html](http://www.leoregus.org/Adventure.html). Contact (650) 430-0731 or [adventure@leoregus.org](mailto:adventure@leoregus.org).

**28-FT GULFWEEED, 1955.** Napa, CA. Ready to go back in the water after haulout this month. Owner motivated. Make offer. Contact (707) 738-1405 or [laird@ljdurham.com](mailto:laird@ljdurham.com).

**26-FT MCGREGOR, 1992.** Loreto, Mexico. \$3,950. Boat and trailer in Loreto, Honda 8hp long-shaft in CA. Water ballast with daggerboard. Ideal for Cortez. Boat sitting in outside storage in Loreto for the past 5 years. Contact (530) 318-2264 or [csa01@jps.net](mailto:csa01@jps.net).

**28-FT ISLANDER, 1978.** Richmond Yacht Club. \$11,500/obo. Dependable Bay boat and family cruiser. Rebuilt Volvo MD7A. Teak interior, roller furl jib. Edson wheel. Sleeps 5. Custom details. Located at Richmond Yacht Club, Pt. Richmond. (510) 459-1129 or (510) 798-4448 or [karenkittle@comcast.net](mailto:karenkittle@comcast.net).



**CAL 2-27, 1978.** Mulege, Baja. \$7,000. Moored Conception Bay. Equipped to cruise. New standing rigging and furler, main, 2 jibs, 2 solar panels, Universal 25hp, Origo, 3 anchors, more. Documented. MX Permit. New jobs, must sell. (734) 823-4078 or (867) 634-2777 or [gvsanicke@gmail.com](mailto:gvsanicke@gmail.com).

**28-FT PEARSON, 1977.** Richmond. \$5,500. Price reduced! Must sell, leaving area. Roller furling jib, sails in excellent condition. Sleeps 4 comfortably, enclosed head. Very dry boat, Atomic 4 gas engine. Great Bay sailing boat. Contact (510) 215-9924 or (510) 685-0252 or [cathyaobrien@msn.com](mailto:cathyaobrien@msn.com).

## 29 TO 31 FEET



**30-FT CATALINA CAPRI, 1985.** San Diego. \$13,500. Set up for single-/double-handed sailing. Autopilot, windvane, eight winches. Emergency rudder, tiller, new life lines, roller furling, full batten main, solar panel, trailer. Email for full information: [barry19872000@yahoo.com](mailto:barry19872000@yahoo.com).

**30-FT SANTANA 30/30 RC, 1986.** Port Huron, Michigan. \$17,995. Well cared for, race winning, fresh water, 2-owner boat. A comfortable fast racer! Cruiser great for getting away or family vacations. Too much equipment to list. More at [www.cranialmining.com/santana](http://www.cranialmining.com/santana). Contact [santana@cranialmining.com](mailto:santana@cranialmining.com) or (810) 987-8949.



**31-FT HARBOR CREEK, 1978.** Harbor Creek. Well equipped and in good shape. Sails in good shape. Both light and heavy winds. Perfect boat for a singlehander or a couple. More at [www.svisisailor.wordpress.com](http://www.svisisailor.wordpress.com).

**30-FT WYLIECAT, 1996.** \$75,000. #3, Silkye. 5hp outboard. Faux-finished carbon mast. Carbon rudder shaft, upgraded wishbone, spinnaker, Autohelm, re-done nonskid and bottom. A rare chance to own one of these fast, stable, easy-to-sail boats. (510) 521-7730.



**30-FT BRISTOL CHANNEL CUTTER.** 1997. \$125,000/obo. 30-ft Lyle Hess Bristol Channel Cutter, *Tigress*, 1997, sistership to the Pardeys' famous *Taliesin*. Extraordinary craftsmanship. Mahogany on oak. Teak cabin and decks. Hull so fair many think it's fiberglass. Amazing teak and birdseye maple interior. 27hp Yanmar. Well equipped: roller furling, storm trysail, spinnaker, sea anchor, radar, chartplotter, autopilot, windvane, refrigeration, VHF, 110V electrical, inverter, Force10 heater, Force10 stove/oven, windlass, 9-ft Fatty Knees dinghy with sailing kit, much more. Pristine like-new condition. More info at [www.tigress-bcc.com](http://www.tigress-bcc.com) or (650) 868-0348.

**30-FT HUNTER, 2002.** Hidden Harbor. \$39,500. Beautiful boat. Professionally maintained and ready to go. Yanmar diesel. Roller furling, All lines led aft. Comfortable cabin. VHF. CD stereo. Propane galley. Fun to sail. Email for pictures: [calvertvet@exwire.com](mailto:calvertvet@exwire.com). Call (530) 389-8387 or (530) 346-2266.

**30-FT CAL 3-30, 1974.** Napa Valley Marina Dry Storage. \$5,000. Best fixer ever! Needs electrical work, fuel pump and interior varnish, but ready to sail. Large sail inventory. Very sturdy, stable boat. See website for info and photos: <http://dumpyoldbroad.blogspot.com>. Contact [reencanham@earthlink.net](mailto:reencanham@earthlink.net) or (707) 746-5076.

**30-FT ISLANDER, 1979.** Marina Bay, Richmond. \$5,000. Nice, clean boat, roller furling, good main and jib. Volvo motor runs, but needs work. (530) 343-9391 or [plutonic1@aol.com](mailto:plutonic1@aol.com).



**29-FT WINGA 862, 1984.** Stockton Sailing Club. \$17,200. *Swedish Promise*. Fractional sloop, racer/cruiser. 6 halyards. New running rigging, new complete wiring, new panel, 2 new AGM batteries, autopilot and backup, new VHF w/remote, stereo, aft cabin w/two single berths, fridge, stove, BBQ, new head/hoses, new alternator, waterpump, Volvo Penta MD5 w/sail-drive, new 5 coats barrier w/2 antifouling, Mack Pack main, Mack 110 genoa, 150 genoa, spinnaker, asymmetrical w/socks, new upholstery, new cockpit cushions, dodger, bimini, too many extras. Perfect salon. Unique, comfortable, dry. Largest 28.5' boat you'll see! Email for pics: [tomsps@sbcglobal.net](mailto:tomsps@sbcglobal.net) or (209) 470-5804. More at <http://swedishpromisewinga862.wordpress.com>.



**30-FT WILLARD CUTTER, 1976.** San Mateo. \$29,500. Willard 8-ton world cruiser 35.2 LOA. Cutter rigged, affordable, full keel, blue water capable sailing vessel, designed by William Crealock. Liveaboard 10.6 beam. Full specs and photos: <http://amazonrainforestplants.com/willard30forsale.html>. Contact (541) 554-3356 or [michael.chadd@gmail.com](mailto:michael.chadd@gmail.com).

**29-FT COLUMBIA, 1964.** Alameda. \$6,500. Hull 103, LOA 28'6". Gas engine re-powered with Yanmar 3-cylinder freshwater-cooled diesel, 27.3hp, 177 hours. Interior in very good condition, outside solid, but needs cosmetic work. Larson full-batten main with Dutchman flaking, Schaefer furler with 95% jib. (831) 277-6034.



### RIGGING ONLY ◊ SMALL AD, SMALL PRICES

Standing and running rigging, life lines, furling gear, winches, line, windlasses, travelers, wire and terminals, blocks, vang, and much more.

~ Problem solving and discount mail order since 1984 ~

[www.riggingonly.com](http://www.riggingonly.com) • (508) 992-0434 • [sail@riggingonly.com](mailto:sail@riggingonly.com)



### Get the Reliable, Powerful Wheel Pilot

Quiet & Dependable • Affordable • Built for Immersion  
Easy Owner Installation • Low Power Consumption

831-687-0541

[www.cptautopilot.com](http://www.cptautopilot.com)



### STARBOARD YACHT DELIVERIES

Over 50,000 sea miles • Pacific, Caribbean, Atlantic  
USCG Master 100 GT STCW • Power & Sail

Rick Whiting • (415) 740-2924 • [captain\\_rick@sbcglobal.net](mailto:captain_rick@sbcglobal.net)



### Spaulding Wooden Boat Center

Youth Boatbuilding Program • Community Sails  
Boatworks since 1956 • We Specialize in Wooden Boats  
Become a Member! 501(c)(3)

[www.spauldingcenter.org](http://www.spauldingcenter.org) • (415) 332-3179



**30-FT OLSON, 1981.** Brickyard Cove Marina. \$11,500. Boat is race ready. Two-axle trailer. Nissan 4-stroke, 6hp motor. Double spreader, reinforced mast step. On the trailer at BYC. (530) 542-3641 or dnewman2@pacbell.net.

## 32 TO 35 FEET

**35-FT RAFIKI, 1978.** Berkeley Marina. \$39,500. Cruising sailboat. Fiberglass hull. Beautiful teak interior. New (2007) Universal 35hp diesel, (18 gal) fuel tank. Chartplotter, radar, autopilot. Dinghy davits, outboard crane. Hand-shower in head. Recent (2009) survey available. <http://rafiki35.wordpress.com>. (925) 997-2500 or rafiki.35.sailboat@gmail.com.

**34-FT OLSON, 1988.** Berkeley. \$42,750/obo. Classic, tall mast, documented, only 39 made, built by Ericson, full cruise package, '99 Universal diesel with 700 hours, '06 rigging, 5 sails, Harken furler, tiller, anchors, navigation, loaded, very clean. (925) 980-5056.

**34-FT EXPRESS, 1988.** RYC. \$59,750. *Two Scoops*, well maintained, well sailed, fast with great sail inventory. Equipped with stove, refrigerator, GPS, radar, VHF with cockpit and nav station locations and marine AM/FM stereo. Contact [c\\_longaker@sbcglobal.net](mailto:c_longaker@sbcglobal.net), (415) 450-1113 or (415) 383-1006.



**34-FT SABRE, 1985.** Belvedere SFYC. \$49,500. *Moonlight Lady*. Very well maintained. Major overhaul 2004: New spars (Ballenger). New sails, main and 135. Antal track, Antal clutches. Harken traveler, carbon extendable whisker pole, Harken track-on mast, Awlgrip topsides, Garmin GPS 3205 color chartplotter, rebuilt pedestal 2006, engine overhaul 2008, brightwork 2011, bottom paint 2012. Other sails: 105 and 150. Sleeps 6. Contact: (415) 218-9393 or (415) 435-4074 or jfsails@comcast.net.

**35-FT CORONADO, 1971.** Monterey. \$19,500. Ketch rigged. Good condition. Great liveaboard with high freeboard. Docked in Monterey City, slip A-79. Slip may be transferable. (559) 288-1386 or kfa1@aol.com.



**34-FT C&C, 1981.** Emery Cove Marina. \$27,000. Racer/cruiser in excellent condition, Yanmar diesel, roller furling, Bariat ST winches, rod rigging, hydraulic backstay, 3 headsails, plus spinnaker, 3-burner propane stove, dinghy with outboard, shower and Lectra-San system. (925) 376-1081 or (925) 212-6080 or zedaker5@hotmail.com.



**33-FT IOD.** International One Design, 1947. Tiburon. \$8,500. Wooden boat in fairly good condition. Very fast boat, full set of fairly competitive sails. Needs cosmetic work and some hull work, but ready to race. Very competitive one design fleet with a long summer series culminating in a qualification for the IOD World Championships held in Norway, Sweden, UK, Canada, Bermuda, Boston, Long Island, Connecticut, Nantucket, Northeast Harbor and San Francisco. Check out the International One Design World Class Association at [www.internationalonedesign.org/home](http://www.internationalonedesign.org/home). More info at <http://sfiod.org/sales/3>. Contact (415) 250-7854 or zpupan@yahoo.com.

**ERICSON 35 MK II, 1977.** Richmond YC. \$39,000. Bruce King Design. Loved and well maintained. Equipped for cruising. Sleeps 5. The years have caught up to us, must sell! Detailed info and photos on website: [www.ericson351977.blogspot.com](http://www.ericson351977.blogspot.com). Contact [sqsailors@hotmail.com](mailto:sqsailors@hotmail.com) or (925) 935-4413.

**32-FT WESTSAIL.** Pillar Point Harbor, Half Moon Bay. \$34,500/obo. Hull #417. Teak/mahogany interior: center table/fwd locker layout. 3 headsails, 1 staysail, 1 drifter. Perkins 4-108. Needs new mainsail and boom. Contact (650) 303-3901 or pgclausen@gmail.com.

**34-FT SAN JUAN, 1980.** Marina Bay, Richmond. \$30,500. Well maintained. New bottom paint 6/12/12. Wheel steering. Ample storage. Main double reefed, 110% roller furling jib and 155% genoa. Rod rigging. Hot/cold water. Sleeps six. Many extras. Contact (530) 673-8457 or sf885@sbcglobal.net.



**35-FT YOUNG SUN CUTTER, 1981.** San Carlos, Mexico. \$54,800. Proven blue water cruiser, ready to sail the world, with a bombproof fiberglass hull. Fully cruise equipped, designed by Robert Perry, same layout as Tayana 37, but at a bargain price. <http://youngsun.squarespace.com/specs>. Email [mohrmonte@gmail.com](mailto:mohrmonte@gmail.com).

**35-FT J/105, 2000.** Tiburon. Price to be negotiated. Blue Hull. Wheel. Autopilot. Racing main, jib, genoa, spinnaker. Sparingly sailed. Never damaged. Email [bronnerlehe@yahoo.com](mailto:bronnerlehe@yahoo.com).



**ERICSON 35 MK II, 1972.** Point Richmond. \$25,500/obo. Well maintained. Yanmar diesel engine. Electric windlass. Autopilot. New Awlgrip paint. Roller furler. Self-tailing winches. New interior. More at: <http://mavericksausalito.blogspot.com>. Contact (916) 247-6962 or (916) 704-1898 or rickfalconer73@gmail.com.



**33-FT HOBIE, 1979.** Marina del Rey. \$18,000. Turbo Hobie 33 with retractable keel, many new sails (class and turbo), carbon boom, open transom, kelp window, outboard, LED tri-light, boat battery, autopilot, many more upgrades - great deal! Email for photos: [bhuffman33@gmail.com](mailto:bhuffman33@gmail.com).

## 36 TO 39 FEET

**36-FT ISLANDER I-36, 1974.** Berkeley. \$27,500. Exterior brightwork - April 2012, bottom paint, outlass bearing - May 2011. New full cockpit enclosure and bronze tint windows, 2 upgraded headsails, 2 Harken #46, 2-speed self-tailing winches. Farymann R30 diesel engine, radar, GPS. (503) 481-9769 or cahhiway@aol.com.

**36-FT HANS CHRISTIAN, 1975.** Oyster Point Marina. \$39,000. A proven cruiser from Alaska to New Zealand. *Good Bones* needs new sails and a little TLC to restore her to offshore condition. Monitor wind vane, dinghy and more. USCG documented. Contact (415) 337-5303 or svtekin@gmail.com.

**38-FT MORGAN CUSTOM, 1978.** Marina Bay. \$18,500/obo. Strong, fiberglass ocean sailboat. Beautiful, fast, handles easily. Survey \$35K/\$247K. Large dry dodger/bimini, teak interior, Yanmar diesel, roller furling, autopilot, refrigerator, solar. Lifetime bottom. Encased keel and fuel tank. Call (916) 521-0470 (cell), or (760) 347-8207.



**CATALINA 36 MK II, 2001.** Monterey. \$104,999. 35hp diesel 240 hours, radar, GPS, roller furling with two sails, Dutchman flaking main, propane, refrigerator, Raymarine instruments, autopilot, dodger, windlass remote, whisker pole, PSS shaft seal, transferable Monterey slip. More at <http://c36forsale.com>. Contact (831) 204-2123 or erik@c36forsale.com.

**36-FT ISLANDER FREEPORT.** Model B, 1978. Morro Bay. \$47,000. Roller furling, Bruce, 2 Fortress, windlass, radar, 2 VHF, remote mic, chart plotter, Autohelm, depth, wind gauge, refrigerator, CNG stove/oven, 1000-watt inverter, dual bank charger, fireplace, Perkins 4-108. Contact [bobjenkiziar@sbcglobal.net](mailto:bobjenkiziar@sbcglobal.net) or (559) 707-7344.

**37-FT RAFIKI, 1978.** Long Beach. \$58,000. Upgraded cutter, no teak decks, 1600 hrs, heavy duty furling for stay/genoa. New varnish, updated radar, radio, GPS, autopilot, depth, wind, speed refrigeration, new interior. Upgrades. Too much to list, beautiful boat. (310) 251-8860 or bbfalcon@yahoo.com.

**37-FT CREALOCK, 1979.** Monterey. \$50,000. Cruising consultants, new LPU entire boat, new interior, new Yanmar. Email for pics and video. (831) 234-4892 or dcd987@gmail.com.



### Alberg Design Fleet of SF

...keeps the great boats of Carl Alberg alive!  
Pearson Ariels, Tritons, Alberg 30s, Cape Dorys, etc.  
*Monthly Breakfasts - Cruising - Racing*  
More info at [www.albergsailboats.org](http://www.albergsailboats.org)

Remember Your Crew This Sailing Season...  
Give the gift of *Latitude 38* Logowear  
[www.latitude38.com](http://www.latitude38.com) • (415) 383-8200

### NOR'SEA 37

Designed by Lyle Hess Built by Michael Hess of Hess Marine  
Big Sister to the NOR'SEA 27  
Stout Offshore World Cruiser Cutter Rig Canoe Stern  
[WWW.NORSEA37.COM](http://WWW.NORSEA37.COM) • (855) 460-4455



### MOBILE MARINE PUMP-OUT SERVICE

\$25 per pump up to 40 gallons.  
Includes fresh water flush and a packet of treatment.  
20% discount for regularly scheduled service.  
[www.mobilepumpout.com](http://www.mobilepumpout.com) • (415) 465-0149 • [tim@mobilepumpout.com](mailto:tim@mobilepumpout.com)

**39-FT BENETEAU OCEANIS, 1993.** Hidden Harbor Marina, Rio Vista. \$70,000. Quantum main with lazy jacks, recent Yanmar 3JH2, in fresh water since survey and bottom paint-5 years, beautiful mahogany interior, large galley with micro, full dodger and bimini, 3 staterooms, 2 heads, GPS, depth sounder, VHF, great Delta boat with shoal draft, comfortable sailing on San Pablo Bay or enjoying wine and cheese in the shaded cockpit. Room for friends and family. (775) 741-6427 or drbeck@sbglobal.net.

**36-FT PEARSON, 1985.** Sausalito. \$45,000. Priced to sell. Owned for 15 years and am 2nd owner. Equipment: Roller furling jib, Dutchman system on main, Forespar rigid vang, 3-blade feathering prop, dodger, lifesling, life jackets, BBQ, complete kitchen setup, more. Original Yanmar diesel with only 385 hours. Original purchase receipt, owner's manual, sail plans, etc. Hauled, painted Oct '10 along with new cutlass bearing. Beautiful interior in near-new condition. Insurance survey in Feb '11 valued at \$70,000. Great boat at a great price. Located at Schoonmaker Point Marina, slip C-72. More at [www.flickr.com/photos/rgt-pics](http://www.flickr.com/photos/rgt-pics). Contact (925) 286-8738 or Bobgthomas@EarthLink.net.



**39-FT FREYA, 1978.** San Rafael. \$60,000. Landlocked family selling well-loved boat! World cruising, liveaboard, and Bay sailing. NEW: fuel tanks, standing rigging, radar/chart plotter, batteries, dodger, etc. Built by Gannon Yachts. Yanmar, SSB, Monitor windvane, Profurl, and more. Contact [torangeiser@hotmail.com](mailto:torangeiser@hotmail.com) or (415) 717-5815.

**37-FT RANGER, 1978.** San Pedro, CA. \$16,500. Ready for Catalina, needs some work to go south. 25hp Westerbeke diesel, custom interior! Furling jib, inflatable dinghy + 5hp outboard. Motivated seller. Contact [lkaikacaptain@gmail.com](mailto:lkaikacaptain@gmail.com) or (858) 449-5285.

**36-FT HUNTER VISION, 1992.** San Diego Marriott Marina. \$48,900. A sweet boat. Exceptionally clean and well maintained. Priced to sell. Stylish cruiser with free standing mast. Wide open interior-light and bright. Teak and holly cabin. Electric halyard winch, single line reefing. All lines leading aft. Yanamar 30hp engine, 35 gal fuel tank, 75 gal new stainless steel water tanks. Easy to sail. Fully loaded. Call for details: (928) 412-7475 or email [lteglas@aol.com](mailto:lteglas@aol.com).

**36-FT ISLANDER, 1973.** Catalina Island, Avalon Harbor. \$8,000/obo. Cruising history, ready to be restored. Great running Yanmar 2QM15. No huge issues. Priced to sell. If interested, please call for more info. (310) 528-3437.



**39-FT FREYA, 1981.** Aeolian YC, Alameda. \$25,000. Documented vessel. Heavy fiberglass hull by Gannon Yachts. Owner-finished in 2001 in Portland. Topsides are fully functional, but need significant cosmetic work. Was liveaboard in Eureka. Roller furling. Low-hours Perkins 4-108. 8-ft Zodiac. 45lb CQR. Electric windlass. Force 10 heater. VHF, depth, fuel gauges. Norcold 12-120-volt icebox. Pressurized water. Head with holding and macerator pump. More. [www.sailboat-freya.blogspot.com](http://www.sailboat-freya.blogspot.com). Contact (707) 980-3192 or [wirth11@att.net](mailto:wirth11@att.net).

**36-FT CATALINA 360, 2007.** Santa Barbara. \$122,000. 35hp Universal, 140 hrs. Excellent condition, professionally maintained. In-mast furling, color radar, Raymarine tri-data displays, autopilot, GPS, inverter, refrigeration, 3 batteries, windlass (up/down control), oversize bow/stern ground tackle, dodger, full bimini. Santa Barbara slip available. Email for complete equipment list. (805) 969-6327 or [paulconnien@gmail.com](mailto:paulconnien@gmail.com).

## 40 TO 50 FEET



**40-FT PEARSON BOUNTY II, 1961.** Brisbane Marina. \$28,500. Early bulletproof fiberglass. Sailed from Hawaii. Loaded. Sloop rig, Harken roller furling. 5 sails in great condition. Yanmar 27hp 3GM30F diesel engine, 75-watt solar panel, Ampair 100 wind generator, 4 AGM batteries, Prosigne Truewave 1000 inverter, Monitor self-steering windvane, Icom IC-M700 Pro with Factor III modem, Dynaplate, backstay antenna, Apelco VHF, propane Force 10 stove, Waterlog watermaker, Interphase depth-finder, lots of extras. This boat is a steal at \$28,500. (510) 410-5401.

**40-FT OLSON, 1983.** Squamish, B.C. \$73,000. Race and cruise equipped, Pac Cup ready, Espar furnace, fridge, dodger, furler, etc. An extensive equipment and sail list. (604) 898-9484 or (778) 879-4272 or [jgugins@telus.net](mailto:jgugins@telus.net).



**44-FT CATALINA MORGAN, 2007.** Seattle, WA area. \$287,500. 2007 mint condition. A real deck salon. Great Northwest and world cruiser. 75hp Yanmar 8+ cruising. New batteries, cruising spinnaker, power winches, hydronic heat, Raymarine C120, radar, autopilot, bow thruster. Will trade for powerboat or real estate. (408) 666-3261 or [jerrysaia@aol.com](mailto:jerrysaia@aol.com).



**44-FT KELLY PETERSON, 1977.** Daytona Beach, FL. \$110,000. Well maintained/new rigging/mast pulled, relit, repainted like new. Good access to Perkins 4326 diesel and water tanks. Diving equipment, great galley, sleeps 7. New electronics, inverter/charger, Navtex, Raymarine radar, Icom SSB, West Marine VHF. Fully battened main, 110 genoa, new storm sail, beautiful spinnaker. Lots of tools/equipment and parts. Sails like a dream! Left Alameda 14 yrs. ago. More at [www.grace44.com](http://www.grace44.com). Contact (702) 767-8323 or (702) 767-8322 or [kjng38701@aol.com](mailto:kjng38701@aol.com).



**42-FT FREYA, 1983.** San Carlos, Mexico. \$79,000. Larger version of classic double-ender, steel, new mainsail, new windlass, 50hp, 24/12v, Aries windvane, autopilot, windgen, solar, fridges, Ham/VHF, liferaft, dinghy, mahogany interior, easily single-handed. Email [trevand1@yahoo.ca](mailto:trevand1@yahoo.ca).



**CAL 2-46, 1974.** Point Roberts. \$119,000. Ready to cross oceans. Lovingly maintained and restored. 2012: Engine overhauled, standing rigging, furler, hydrovane, sails. Also electric winches, davits, watermaker, spares! Standup engine room, teak/holly sole, much more! <http://merrydolphin.zxq.net>. Contact (250) 505-4941 or [nelson2bed@gmail.com](mailto:nelson2bed@gmail.com).

**41-FT MORGAN CLASSIC MODEL.** 1991. San Carlos, Mexico. \$93,000. Cruiser, in primo condition, ready to go. Spacious interior - must see to appreciate. Recent survey. See website for current photos, complete equipment list: <http://sailboatvagari.blogspot.com>. (520) 825-7551 or [stanstreb@gmail.com](mailto:stanstreb@gmail.com).



**41-FT WAUQUIEZ CENTURION 41S.** 1999. Grenada. \$165,000. Comprehensive cruising inventory. Ocean ready. Refit in 2009 included new sails and rigging, upgrade of electrical and navigation systems. Owner's version. Linens and dishware included. [www.mindemoya.info](http://www.mindemoya.info). Contact (231) 620-3920 or (231) 620-3921 or [mindemoya@gmail.com](mailto:mindemoya@gmail.com).

**41-FT HUNTER 410, 2000.** Alameda. \$110,000. Fully equipped oceangoing yacht with liferaft, EPIRB, chartplotter, radar, autopilot, dodger, in-mast mainsail furling, roller-furling jib, heart inverter, two cabin layout, 3-burner stove/oven, VHF, leather, BUC value: \$128k. More at <http://boatpoint.com.au/reviews/2000/hunter-yachts-410-9029>. Contact (415) 377-6651 or [salcaide@yahoo.com](mailto:salcaide@yahoo.com).



**45-FT GARDEN YAWL.** One off, double end, 3 years in restoration, 98% completed, cold-molded over original strip planked, new electric motor. \$60K as is, or \$? to finish. Contact (916) 847-9064 or [stevebarber046@mac.com](mailto:stevebarber046@mac.com).

## MARINE SURVEYOR

Sharpe Surveying & Consulting. SAMS Accredited Marine Surveyor. Serving the San Francisco Bay and Delta.

[RSharpe@SharpeSurveying.com](mailto:RSharpe@SharpeSurveying.com) • (510) 337-0706

## 'lectronic Latitude

Just like the magazine but... online, three times a week, and totally different! Find it at [www.latitude38.com](http://www.latitude38.com)!



## PROFESSIONAL DELIVERY CAPTAINS

San Diego based, USCG Master 100 GT. Sail and power.

ASA-certified instructional deliveries. Pacific Mexico and Baja Bash specialists. [davidbrotherton@yahoo.com](mailto:davidbrotherton@yahoo.com) • [www.boatdeliverycaptain.org](http://www.boatdeliverycaptain.org) • (619) 913-7834 •



## Afterguard Sailing Academy

The Affordable Way to ASA

ASA Basics to Ocean • Crew Intro to Cruising Prep  
(510) 535-1954 • [www.afterguard.net](http://www.afterguard.net)

**47-FT CATALINA, \$295,000.** Customized bluewater ready. Extra fuel capacity, 110 or 240v, watermaker, chartplotter, radar, AIS, coldplate fridge/freezer. Custom cabinets and workshop, dive compressor, in-boom furler, staysail, autopilot, wind vane, new hard dodger, heat-air, Autoprop, Much more. (916) 607-9026 or cestlavie\_2000@hotmail.com.



**43-FT HANS CHRISTIAN CHRISTINA.** 1986. Redwood City. \$179,000. Volvo TMD 30A 90hp. Furuno 1720 radar. Balmar 1200 windlass. Harken furling on jib and staysail. Barent winches. B&G 330 instrumentation. Newmar PHD-25 battery charger. Raritan 12 gallon hot water heater. Packless sealing system (Svendsen's). Very roomy and comfortable 3-cabin layout (Pullman master). VacuFlush/Tank Watch 4 monitoring system. Beautiful new granite countertops in galley with flowing colors to match the tongue-and-groove teak throughout. Norcold refrigeration. Force 10, 3-burner propane stove. Alpenglow lighting. All new enclosed dodger/cockpit (watertight) with covers and privacy screening for all windows... only the finest materials used. (650) 207-2253 or ps4010@aol.com.

**41-FT SCEPTRE, 1986.** Crescent Beach, B.C. \$168,000. Original owners. Professionally maintained. Recent survey and bottom paint. Email or call for more info and pictures: raceaway@shaw.ca or (604) 535-9373.

**44-FT HARDIN VOYAGER, 1977.** Marina Palmira, La Paz, BCS, Mexico. \$79,000. A spacious fiberglass, ketch-rigged veteran of the Sea of Cortez and west coast of Mexico. A traditional liveaboard and long range blue water cruiser with rare two-cabin, two-head layout. Center cockpit with hard dodger. Recently recaulked teak decks. Aft cabin has transom windows above the thwartships queen-size bunk and opening portholes for ventilation. Go to [www.YachtWorld.com](http://www.YachtWorld.com) for specs. (530) 541-4654 or mortmeiers@aol.com.

**40-FT HUNTER, 1986.** South Beach, SF. \$65,000. Comfortable, fast and fun. Great liveaboard. Queen centerline berth. Yanmar diesel. 6 sails. New in 2012: Instruments, running rigging, charger/inverter, canvas covers, cockpit cushions, haulout/bottom job, teak refinished, more. <http://h40.techuity.com>. Contact (650) 534-4795 or tcsmith00@gmail.com.



**40-FT SANTA CRUZ, 1983.** Monterey. \$99,000. A fast racer/cruiser. Excellent condition. Extensively updated. New Ballenger spar and rod rigging. Re-wired. New Raymarine instruments, windlass, inverter, refrigeration/freezer. New gelcoat decks and topside paint. New dodger. Custom transom ports. For photos and info see website: <http://santacruz40forsale.com>. Contact (831) 915-3540 or jimbo@mbay.net.

**50-FT MARINER MOTORSAILER.** 1980. Redwood City. \$165,000. Great liveaboard cruising boat. 2 staterooms, 2 heads, 300 gals fresh water, 400 gal/day watermaker, upright fridge/freezer, separate deep freeze. Too much other equipment to list. Please contact for complete list. Contact (831) 335-3573 or ladyhawke50ft@yahoo.com.



**46-FT JEANNEAU SUN ODYSSEY 42.2.** 2000. Tacoma, WA. \$134,000. This salt water veteran is fully equipped with all the necessary equipment to take you offshore in the direction of your dreams! She just got back from a cruise in the Med and the Caribbean and is lying Tacoma, WA waiting for you to prep her for her next voyage. She is a rare 3-cabin/3-head model, perfect for a family or larger group cruising - each cabin has its own head. Great charter opportunity for America's Cup next year! The vessel has many upgrades - and lots of spares! (206) 992-6637.



**47-FT CATALINA, 2000.** Long Beach, CA. \$185,000. Excellent condition and priced to sell. Call or email for more details, photos and spec sheet. (626) 807-0061 or sailboat470@gmail.com.



**MORGAN 462, 1981.** Sausalito Yacht Harbor. \$119,000. Bulletproof center-cockpit cruising ketch, keel-stepped masts, integral ballast, skeg-hung rudder, external chainplates, two cabins/heads, many new systems, immaculate. More at <http://s766.photobucket.com/albums/xx309/tmesser/Morgan%20462%20Cruising%20Sailboat/?albumview=slideshow&tr>. Contact (707) 334-3670 or baryb@aol.com.



**43-FT SERENDIPITY, 1980.** \$85,000/obo. *Lone Star*. Doug Peterson's SORC Serendipity 43. A winning combination: great performance and gracious living. The perfect cruiser. Must sell now. Email for brochure (specifications and current photos): [svlonestar@yahoo.com](mailto:svlonestar@yahoo.com).



**44-FT KELLY PETERSON, 1977.** Chula Vista. \$114,000. Blue water performance cruiser. Great liveaboard, cutter rig, 2 heads, solar panels, watermaker, wind vane, 12v fridge and freezer, 3-burner Force 10 stove, new main, new batteries, wind vane. For more info go to: <http://kp44-odyssey-forsale.blogspot.com>.



**44-FT TARTAN 4400, 2003.** Channel Island Harbor. \$399,000, or trade?. Reduced price! Dark green hull, low hours, bow thruster, electric winches, vacuflush heads, spinnaker, new batteries, new LP and bottom paint, numerous other options/upgrades. See test sail at: [www.youtube.com/watch?v=ckZHxXEAMec](http://www.youtube.com/watch?v=ckZHxXEAMec). Contact (amjohn@sbcglobal.net or 530) 318-0730.



**41-FT NEWPORT, 1984.** Bruno's Island Marina. \$49,000. Price reduced. Mexico vet, radar, GPS, autopilot, 40hp Universal diesel, solid rod rigging, 38 gal. fuel, 60 gal. water, sleeps 6, 8-ft dinghy with 9.9hp Nissan. Contact [raaddink@yahoo.com](mailto:raaddink@yahoo.com) or (707) 688-0814 or (707) 290-9535. 1200 Brannan Island Rd.



**40-FT OLSON, 1983.** Redondo Beach, CA. \$84,500. *Ono* is the perfect racer/cruiser. First overall Newport/Ensenada and Santa Barbara/King Harbor. All race equipment and sails. Comfortable for 8 people cruising. Full galley, refrigeration. Ultralight design, fast, easy to sail. Email [folkman@verizon.net](mailto:folkman@verizon.net).



**44-FT NORSEMAN 447, 1981.** San Diego. \$165,000. Aft cockpit, cutter rigged sloop, offshore pedigree, well maintained, many recent upgrades (sails, rigging, etc), Baja ready, RIB w/outboard, solar, SSB, call or email for more info. (619) 504-8733 or jimkulas@cox.net.

**42-FT CATALINA, 1990.** South Beach Harbor, San Francisco. \$89,900. Great condition. Extensive upgrades. Full specs at: <http://leluya.blogspot.com>. Contact [leluya123@gmail.com](mailto:leluya123@gmail.com) or (650) 716-4548.



★ ★ ★ ★ ★  
**STARPATH** Online Courses  
 in Navigation and Weather  
[www.starpath.com](http://www.starpath.com) 800-955-8328

**DOGIEVENTURE** – A doggie daycare on the go!  
 Morning, mid-day or afternoon sessions available in San Francisco  
**Training • Boarding**  
[www.doggieventure.com](http://www.doggieventure.com) • (415) 314-7541

**MAÑANA DOESN'T MEAN TOMORROW!**  
 A Wild & Crazy True-Life Sailing Adventure in Mexico.  
 3 Years Living It ≈ 10 Years Writing It ≈ 1 Weekend Reading It!  
[www.mananadoesntmeantomorrow.com](http://www.mananadoesntmeantomorrow.com)  
 By David Kindopp ≈ [writerdavid2010@yahoo.com](mailto:writerdavid2010@yahoo.com) ≈ (916) 612-7840

**YOGA FOR SAILORS ON THE SAN RAFAEL WATERFRONT**  
 Perfect for beginners and those seeking to balance strenuous activity with gentle stretching, rest and recovery.  
 Small group classes Tues/Thurs and private sessions.  
 (415) 785-4530, [www.bowyoga.com](http://www.bowyoga.com).





**50-FT FD-12, 1981.** Sea of Cortez. Unsinkable fully equipped blue water cruiser, AK/Mex/SoPac vet. Superb galley in pilothouse. 2 staterooms fwd and master stateroom aft w/berths for 5-6 and great fore/aft privacy. Reduced price. See website for details: [www.svdaydreamer.com](http://www.svdaydreamer.com).



**41-FT MORGAN OUT ISLAND, 1981.** Glen Cove, Benicia. \$49,900/obo. Center cockpit, 416 ketch rig. Great coastal/ocean cruiser. Shoal draft boat designed for chartering in Caribbean. Spacious layout down below, separate forward cabin w/head/shower and hanging locker. Ultrasuede cushions, updated lighting, Dickinson diesel heater. Refrigeration/freezer, three-burner propane stove/oven, microwave. Full walk-thru to master stateroom w/head/shower and separate cockpit entrance. Surprising amount of storage/stowage for a 41-ft vessel. Newer sailcovers and dodger. Rigid boom vang. Great Perkins 4-154 engine. Dinghy davits off transom. Amazing cruising yacht, in great condition at a bargain price. Our plans have changed, so add your custom electronics and go on the next adventure! Call Ken. (415) 269-2971.



**43-FT TASWELL, 1988.** Alameda, CA \$239,000. Bluewater cruiser. Major refit in 2007, then cruise perfected. Full details at [www.yachtsoffered.com](http://www.yachtsoffered.com), listing: 1291827. Contact Steve at (530) 748-8010 or [lotus48@att.net](mailto:lotus48@att.net).



## 51 FEET & OVER



**57-FT DUDLEY DIX, 1991.** Shelter Bay Marina, Panama. \$250,000/obo. Ready to circumnavigate again! Steel cutter, 3 staterooms, watermaker, generator, dinghy, dive compressor. Too much to list. Ready to go cruising in the Caribbean or Pacific from Panama! [svrenegade@hotmail.com](mailto:svrenegade@hotmail.com).



**60-FT LAURENT GILES, 1976.** Seattle. \$189,000. 1976, 60-ft ketch *Princess Irene*. Built to highest possible standards. Documented vessel. Yacht is designed for ocean passage making with two crew. Built by Royal Huisman. Aluminum hull. Multiple redundant systems including propulsion. <http://sailboatprincessirene.blogspot.com>. Email [dan5619@yahoo.com](mailto:dan5619@yahoo.com).



**53-FT ISLANDER, 1979.** Sausalito \$75,000/asking. Monitor, radar, rewired, new fuel tanks and extensive equipment. Sale by owner. <http://polaris5.weebly.com>. Call (415) 250-4301.



**60-FT STAYSAIL SCHOONER, 1997.** Sausalito. \$149,000. Full keel pilot house schooner. Hartog design. 52' on deck, 60' overall. 15' beam. 35 tons. Staysail rig. This sailboat has two pilot stations; one in cockpit, one in pilothouse. Owner may finance a portion of the purchase price. <http://latitude.idhra.com/forsale>. Call (415) 250-7854.

## CLASSIC BOATS



**32-FT DOUBLE ENDER TEHANI, 1926.** Sausalito. \$30,000. Classic Danish yacht in beautiful shape. Regularly sailed and always maintained. Email me for pictures/info: [pgaetani@gmail.com](mailto:pgaetani@gmail.com) or call (415) 246-7712.



**64-FT BLANCHARD MOTORSAILER.** 1938. Seattle, WA. \$249,000. Classic 64-ft motorsailer, built for the president of the Boeing Company in 1938 by the Blanchard Boat Company in Seattle. Designed by Walter Lynch, Port Orford cedar on oak frames Alaska cedar stringers and teak keel. Complete restoration and updates with new electrical and rebuilt engine. Even has a bathtub onboard. One of a kind. Contact via email or call, [shatarinc@yahoo.com](mailto:shatarinc@yahoo.com) or (206) 730-7300. Interesting trades considered.



**55-FT ALDEN CENTERBOARD YAWL.** 1970. Honolulu. \$68,000. This 1970 recently restored yawl will take you back to the 1930s. It has full cover, 120hp Ford Lehman engine low hours, hand beveled ports, teak deck, gold- and chrome-plated bronze fittings, aluminum main, Sitka spruce mizzen, 55ft overall, 13 ft. beam, amazing interior, mahogany over white oak, newer sails, new refrigeration, wiring, hoses, stainless steel frame, just hauled June 2012. More info at [www.aldendesigns.com/yawls-keel-cb/d0948.html](http://www.aldendesigns.com/yawls-keel-cb/d0948.html). Contact (510) 332-4900 or [vernonthompson@yahoo.com](mailto:vernonthompson@yahoo.com).

**65-FT CHESAPEAKE BUG EYE.** Half Moon Bay. \$30,000/obo. Beautiful, all clear fir, ketch. See web page, [www.sunstarsail.com](http://www.sunstarsail.com) or call for more info. (530) 467-3173 or [sunstarsail@yahoo.com](mailto:sunstarsail@yahoo.com).



**60-FT STAYSAIL SCHOONER, 1935.** (70-ft LOA). \$110,000/obo. *Volunteer* (Zoe H). Designer, Edson B. Schock; builder, Port Boat Works, (Wilmington, CA). Built concurrently with Humphry Bogart's yacht *Santana*. Veteran of four TransPacs (winner 1939, Aloha Class B). On-screen home of actor Jack Klugman in Universal Studios long-running television series, *Quincy, M.E.* Colorful history including WWII submarine patrol, Mexican charter service and El Salvadoran registry. Last raced 2005 SF Master Mariners, winner Dead Eye trophy. Old world craftsmanship, teak, oak, Honduran mahogany, leaded glass, marble; unique in all the world. One TransPac away from longevity record. Condition weathered; requires much sanding/varnishing to restore to former grandeur. Estimated replacement cost \$3 million. Owner willing to sacrifice for serious buyer. (541) 264-8346 or [schoonervolunteer@yahoo.com](mailto:schoonervolunteer@yahoo.com).



**59-FT ALDEN SCHOONER.** Design #356-B, 2005. Santa Barbara, CA. \$750,000. Rebuilt 2005. Epoxy glued dbl planked kapur (like teak) below w/l. 75% new frames, new deck beams. One knowledgeable owner for past 45 years. Professionally maintained. Email for photos: [captkent2@sbcglobal.net](mailto:captkent2@sbcglobal.net) or call (707) 252-9383.



**19-FT RHODES, 1940.** Hurricane, Utah. \$1,900. Partly restored boat that needs some plank work and re-caulking. Includes steel centerboard, mast, boom, main and jib, rudder, rigging. No known rot. Sturdy cradle on casters. No trailer. More photos on request. (208) 404-8965 or [miketaggett@gmail.com](mailto:miketaggett@gmail.com).

**Yacht Harbor on the Delta Loop!**  
28'-50' Slips and Side Ties, RV & Tent Camping  
1200 Brannan Island Road, Isleton  
[www.brunosisland.com](http://www.brunosisland.com) ☎ (916) 777-6084

*Latitude 38 eBooks*  
FREE \* AVAILABLE WORLDWIDE \*  
[www.latitude38.com/ebooks.html](http://www.latitude38.com/ebooks.html)

**Marine Surveyor**  
**NAMS CMS**  
Consulting - Deliveries  
[bluwater@juno.com](mailto:bluwater@juno.com) • (916) 599-5241



**COMPLETE MARINE WOODWORK**  
Design / Restoration • Expert European Craftsmanship • Interior / Exterior  
Repairs / Maintenance • Marine Windows & Frame Replacement  
Wood & Dry Rot Repairs • Varnish Work • Marine Painting  
**Reasonable Rates • (415) 453-2231 • References Available**

## MULTIHULLS



**23-FT MULTI-23, 2008.** Los Angeles. \$19,000. Fast, fun boat that is perfect for the Bay. Price is firm. New 2hp Suzuki outboard still in the box. No trailer, but can help with acquiring one. Please call for more details. (650) 814-7217 or dave.licata@lanternservices.com.

**37-FT PROUT SNOWGOOSE, 1982.** Sausalito. \$28,000. Cutter, tanbark sails, low hour diesel, big hardtop over cockpit with large solar panels. Hauled July 2012. (415) 331-3612.



**47-FT MAYOTTE/VOYAGE, 1994.** Panama City, Panama. \$219,000. Motivated seller! Survey says \$306,000 value. I say \$219,000 and the 1st one there gets her! I love my wife very much and this is not for her, so am willing to walk away after spending over 2000 hours and lots of \$ to get her ready to go. Many brand new items and systems on *Archies Way*. Mast, boom, all standing and most running rigging totally rebuilt. New Hylalon 11.5 dinghy, watermaker, upholstery, etc. Great for kids, couple or charter. Contact me for all info and photos. This is one of those deals that you will kick yourself for not checking out before it is gone. (253) 617-0808 or garyswenson@hotmail.com.



**42-FT LAGOON 420 CATAMARAN.** 2008. Belize. \$340,000/firm. Loaded 3-cabin owner's version. Well maintained. Factory dual diesel, generator, AC, watermaker, inverter, chart plotter, new sails one year. Perfect family cruising cat. More at [www.facebook.com/media/set/?set=219422708070841.63102.149453491734430](http://www.facebook.com/media/set/?set=219422708070841.63102.149453491734430). Email soteljohn@hotmail.com.



**38-FT CHAMBERLIN CAT, 1992.** Nevis St. Kitts, Caribbean. \$85,000. Custom composite Vac-bagged Divynicell/Vynylester/Biax racer/cruiser. 2 doubles, 1 head, galley up, bridgedeck with seated headroom (4'6", 5'9" in hulls). Queen-sland-built, 20,000 ocean miles. Must sell. Email sydeva@gmail.com.

**48-FT LOOPING, 2004.** Loreto, Sea of Cortez, Mexico. \$399,000 USD. Spacious, luxurious, clean French-built performance catamaran ready to take you cruising. Fully equipped, pristine condition. MUST SEE!! Tour us on YouTube: Uj33dCr9FnY. Details on website: <http://neofsforale.com>. Contact (916) 622-9348 or lloyds@jps.net.

**34-FT GEMINI 105MC, 2005.** Redwood City, CA. \$129,900. Great family or race boat. Perfect for San Francisco Bay, coast, Mexico, beyond. Fast; easy to sail singlehanded without heeling. Spacious deck, 3-bedroom interior. Elegant and comfortable. See more at website: <http://loonasea.gibbons.web.stanford.edu>. (650) 380-3343 or loon.asea@yahoo.com.

## POWER & HOUSEBOATS



**62-FT HOUSEBOAT.** Sausalito. \$35,000. Houseboat 22x62, on 20x55 concrete barge. Absolutely no berth, must be removed from Marin County. Copper roof, V-joint redwood siding. You can rehab what is there, or demo and start from the barge up. A new concrete barge this size would cost \$84,700. (415) 465-0039.

**43-FT VIKING MOTORYACHT, 1978.** Sausalito. \$69,900. Viking is well known for their quality engineering and rugged construction. This vessel is equipped with twin Detroit diesel 6-71's, Onan 7.5Kw generator, new main fuel tanks, new canvas flybridge enclosure, dripless seals, cutlass bearings, new heavy duty AGM 8D batteries, master stateroom Queen walkaround, Vacu-flush head system with Tankwatch monitor. She has been well taken care of with light use. Transfer of prime location Sausalito slip. (650) 400-9813.

**78-FT DESCO TRAWLER, 1963.** Emeryville. Entertaining offers. Beautiful classic yacht operating as a floating B&B, event and concert venue. Great revenue. 5 staterooms, 4-1/2 baths, amazing woodwork, hot tub, views, ambiance, more. Owner financing possible. [www.barkissimo.com](http://www.barkissimo.com). Call for appointment. (415) 265-9706.

**31-FT LIEN HUA TRAWLER, 1985.** Bel Marin Keys. \$41,000. Glass. 6-cyl diesel. 1 GPH. Liveaboard or heavy cruising. Electric WC, 4-burner stove, autopilot. Beautiful interior. <http://haroldrmiller.com>. Contact (415) 299-1087 or (415) 883-3890 or MillerPI@Comcast.net.



**42-FT TRAWLER, 1979.** Long Beach. \$79,000. 42-ft California LRC twin 3208's. This boat is in really good shape. I would also trade for a motor sailer or remote cabin of equal value. The slip can come with the boat. It has a great view and is a great place to live. I will email pictures upon request. Wnbnfrench@msn.com or (310) 418-0379.

## PARTNERSHIPS

**BENETEAU 393 PARTNERSHIP.** Sausalito. Share available on clean, well-maintained 2002 Beneteau 393 racer-cruiser. Fully equipped above and below, full electronics, diesel, fine interior. Time share 1/8 \$325, 1/4 \$550/month. [www.marigotgroup.com/strider](http://www.marigotgroup.com/strider). Contact (415) 332-4401 or (415) 331-4900 or 393@marigotgroup.com.



**CATALINA 38, 1984.** Sparkman-Stephens. Emery Cove Yacht Harbor. \$10,000, plus...\$250 a month for a week's use. Beautiful, well-maintained vessel. Perfect for weekend at Angel Island, San Francisco, Napa or the Delta. Recently hauled. New upholstery. Custom teak salon and cockpit tables. "Toys" include: fold up bicycles, dinghy with Honda outboard, 32" flat screen, auxiliary generator, pulpit seats and refrigerator. Spinnaker. Purchase is like a timeshare... deposit, monthly use, monthly fee, no maintenance, you could sell your interest. Email 1derful@comcast.net.



**CATALINA 30 PARTNERSHIP.** A great opportunity! Rainbow Harbor, Long Beach, CA. \$275 per month. Well maintained, in a great location and in great shape! Equipped with diesel power, roller furling, dodger, autopilot and more. We pay all expenses - you simply enjoy as much sailing as you like! Or... don't know how to sail? We can teach you. A simple 'month to month' agreement - in the best location! Lots of local entertainment. To find out more, call us now. Tony. (562) 656-6646 or (562) 437-0204 or gonesouth\_oceanmail.com.

**35-FT BENETEAU OCEANIS 35.2, 1998.** Sausalito Clipper. \$35,000. 1/2 ownership. Equity share available for 35K. This boat has winged keel, folding prop, low engine hours, new sails two years ago. New GPS/Nav package this year. Comfortable and fast. Carefully maintained. Clipper Marina in Sausalito. Stable ownership for last 10 years. (415) 300-5879 or (415) 378-5187 or danielcmay@yahoo.com.

**CATALINA 380, 2001.** Sausalito Yacht Harbor. Full electronics, chartplotter, autopilot, and radar. New furling main and jib (2011). Quantum cruising chute, Yanmar 40 with low hours, dodger, electric windlass. Professionally maintained. Equipped for sailing and cruising: 2 cabins, centerline berths, innerspring mattresses, refrigerator, microwave, flat screen HDTV/DVD, electric head, and separate shower. Includes dinghy and outboard. Beautifully finished interior in Ultraleather and Corian. Equity share available, as low as \$335/month, depending on usage. Contact (707) 421-0366 or CSMSam@aol.com.

**PARTNER WANTED.** Southern California. 50% partner desired for 33-36-ft yacht. Can't justify annual expense based on my usage. Offer a Beneteau 331, but is negotiable. I have 31 years of sailing experience, without incident, and take excellent care of possessions. Email Sailor7788@cox.net.



## SOUTH OF THE BORDER

**MEXICOLDER ...YOUR SOLUTION** to refrigeration in Mexico. Simple, silent, supercold. Low amp draw. Spare parts for all other makes, too! Shipping to any Mexican marina. Free spares for Ha-Ha's with purchase of system. VHF 22 Mazatlan. Contact (52 1) 669 150 1433 or mexicolder@hotmail.com.

## Pearl Cruises • Steel 59-ft Catamaran

Dinner/party cruises. New bar deck/dinner deck/utility/bathrooms/galley deck. 2 Volvo MD. USCG inspected. Call Hans (650) 704-3631.

For more info and photos: [www.pearlonthebay.com](http://www.pearlonthebay.com)



Outboard Dealer for Honda, Mercury & Yamaha  
Since 1979

At The Martinez Regional Shoreline  
(925) 229-4881

[www.eaglemarineonline.com](http://www.eaglemarineonline.com)

## OFFSHORE PASSAGEMAKING INSTRUCTION IN THE SOUTH PACIFIC

John & Amanda Neal are dedicated to providing hands-on, documented instruction aboard their Hallberg-Rassy 46 *Mahina Tiare III*, drawing on their combined 584,000 miles and 73 years of experience.  
[www.mahina.com](http://www.mahina.com) • (360) 378-6131

Going Somewhere?

Mexico ≈ Caribbean ≈ South Pacific

Stop by our office and take a bundle of *Latitude 38* magazines along with you.  
We promise you'll be a hero for sharing them with other cruisers!

Latitude 38 • 15 Locust Ave • Mill Valley, CA • (415) 383-8200 • Open M-F 9-5



**PLAN YOUR MEXICO GETAWAY NOW.** at the brand-new, gorgeous Cielo Y Mar condos. Located in Punta Mita, 35 minutes from Puerto Vallarta, available to rent from private owner. On the beach, 10 feet from the water, they offer spectacular views of ocean and mountains, the biggest infinity pool in the area, an endless beach, great surf breaks, great fishing, tremendous views of whales, bird life and the islands. While uncrowded and tranquil, just a five-minute walk to several waterfront restaurants. Choose from a spacious, beautifully furnished one or three-bedroom unit, or an amazing two-story penthouse with lovely shade trellis on the top floor. See details at website: [www.puntamitabeachfrontcondos.com](http://www.puntamitabeachfrontcondos.com). To reserve, call Dona de Mallorca, (415) 599-5012.



**COME JOIN US FOR A WEEK.** Take a vacation! Learn or share your sailing skills with a USCG Captain. This season we are sailing the Sea of Cortez to Acapulco. Join us, or form a group up to 6 of your friends and have the whole boat - a 52' ketch with the finest amenities. Includes, food, fuel, slip fees, scuba gear and tank fills. Great food, good friends, and adventure. See website for all the info: [www.freya52.com](http://www.freya52.com). Or email [freya52@live.com](mailto:freya52@live.com).

**SAILING THE SEA OF CORTEZ.** In La Paz. Sailing with a MacGregor 26X or Herreshoff 28. [www.sailing-baja.com](http://www.sailing-baja.com). Contact [info@hacienda-sol.com](mailto:info@hacienda-sol.com) or call (011-52) 612-123-5440.

## WANTED

**LOOKING FOR PARTNERSHIP.** On small catamaran. San Francisco Bay. Negotiable. Looking for partnership on small catamaran on the Bay. Have 18-ft Hobie Cat in Santa Cruz and 38-ft keelboat in SF Bay. Would like to sail a small cat (wetsuit + trapeze) in SF without trailering from Santa Cruz to the Bay and back. If you have a small cat "near" a ramp and need/want experienced sailors to help you with it let us know. Contact (831) 297-3059 or [pierre.patino@gmail.com](mailto:pierre.patino@gmail.com).

**I WANT TO LIVE ON A BOAT.** SF, Sausalito. \$1,200 for right craft. Boat-savvy professor wants to live aboard a boat for several months while writing. Willing to be low-key. Call or email: (415) 971-1127 or [suni.petersen@gmail.com](mailto:suni.petersen@gmail.com).



## GEAR

**74-FT MAST.** Designed for catamaran. Best offer. (415) 269-5165.

## CLUBS & MEMBERSHIPS

**SKIPPER WANTED.** Alameda. Single boat owner and need crew? We have crew to help sail your boat. Membership includes PICYA, daysailing, events. Meetings: 2nd Thursday each month, Ballena Bay Yacht Club. Social 6:30pm. Meeting 7:30pm. Guests welcome. More info at [www.singlesailors.org](http://www.singlesailors.org) or (510) 239-7245.

## PROPERTY SALE/RENT



**FULLY FURNISHED STUDIO APT.** For rent. Dolores Park location. Convenient to everything. Queen bed, full kitchen. Stocked BR. Views. Month to month lease/2 night minimum. \$2,500/month, \$175/night. 1 per long term, 2 max. Contact (415) 793-5546 or (415) 641-8490 or [Castro126@gmail.com](mailto:Castro126@gmail.com).



**DELTA WATERFRONT PROPERTY.** Gentleman's Ranch. 3 Mile Slough - Rio Vista. \$695,000. 28-acre ranch with 70-foot deep water dock. Property has view of Mt. Diablo. Site for second home. Property features: many outbuildings with water troughs, small corral, etc; livestock (sheep, goats, llamas, alpacas, horses, etc.) production or Ag production (presently hay); hay barn; equipment storage; fruit trees; 1,440 sq ft home with new carpet, paint, appliances, ductless air/heating system, 900 sq ft 2-car garage/shop with built-in cabinets, laundry room, mudroom, office; large carport; security system. [www.century21.com](http://www.century21.com). For more information, call Rebecca Cabral. (707) 249-4479 or [rc1942@aol.com](mailto:rc1942@aol.com).

**5 BEDROOM HOME FOR RENT.** Napa. \$3,400 month. Sail directly to America's Cup from this beautiful 5-bedroom, 3-bathroom home, surrounded by water! South Napa river, deep water dock up to 50'. Fully furnished. (707) 287-3210 or [john@mcintoshco.com](mailto:john@mcintoshco.com).

**SHARE OFFICE.** Light manufacturing space. \$800. Clean bright sunny space on Sausalito waterfront. Approximately 500 sq. ft. Free parking and good company. (415) 332-2509.



**BAY AREA HIDEAWAY.** Mill Valley, CA. Large 1-bedroom apartment, 2 short, flat blocks from downtown Mill Valley, and close to the Bay, beaches and hiking. This is an upper unit, 2 decks, one above a babbling creek, the other beneath the redwoods. Well equipped AEK with dishwasher, full bath, large bedroom with queen size bed. Covered parking, washer/dryer on premises. Hi-speed Wi-Fi, cable, DVD. \$120 a night, 2 night minimum. No smoking, no pets. [www.airbnb.com/rooms/160781](http://www.airbnb.com/rooms/160781). Contact (415) 225-0442 or [franicowan@yahoo.com](mailto:franicowan@yahoo.com).

**FLAT BUILDING LOT.** Humboldt. \$160,000/asking. With a view and boat dock on Humboldt Bay. 50x100 with all utilities in place. One block to a large, sandy beach. Owner financing with a reasonable down. Agent Keith. (707) 498-1620.

## BERTHS & SLIPS

**40-FT BOAT SLIP FOR RENT, PIER 39.** \$425 per month. Great boat slip in the heart of San Francisco! Yet away from the crowds. Security, discount parking, shower and laundry facilities. (425) 643-0614 or (206) 321-3730.

**PIER 39 MARINA BERTH FOR SALE.** San Francisco. \$20,000/obo. 40 x 14 foot berth, currently leased at \$420 per month, SF property tax \$330 per year, visit website for photo slide show, call Larry. [www.415images.com/pier39](http://www.415images.com/pier39). (907) 225-3040 or [loloane@hotmail.com](mailto:loloane@hotmail.com).

**GASHOUSE COVE 35-FT.** San Francisco Marina. \$19,500+\$5,500 transfer fee. 35-ft berth, #474 Gashouse Cove, 33-ft Chris Craft \$19,500 plus \$5,500 transfer fee. View of GG bridge, Alcatraz, free parking, showers, electric Gate 14. Serious buyers only. (530) 520-3068 or [nifty60s@gmail.com](mailto:nifty60s@gmail.com).

**50-FT SLIP, G DOCK-SLIP 22, PIER 39.** San Francisco. \$55,000 - Lease to 2034. Next to breakwater - looking out on the Bay. Wow, what a view! Angel Island, Treasure Island, Golden Gate, Oakland Bay Bridge and Alcatraz. Convenience of the marina office and showers nearby. (530) 274-2007 or [bruceandbarbie@aol.com](mailto:bruceandbarbie@aol.com).

**AEOLIAN YACHT CLUB / MARINA.** Alameda. A full-facility club with slips, workshop, kitchen and hall. Berths under \$5/foot! Special Discount for New Renters: Every 3rd month free during the first 12 months! Membership required. Reduced initiation fee: \$200. [www.aeolianyc.com](http://www.aeolianyc.com). (510) 523-2586 or [aeolianyc@aol.com](mailto:aeolianyc@aol.com).

**50-FT COMMERCIAL SLIP.** Pier 39, San Francisco. \$55,000. Newly constructed J-Dock, slip-6, west side with views of Golden Gate Bridge, Angel Island, and Alcatraz Island. Special rates for owners at Pier 39 parking garage. Sublease until 2034, contact James. (650) 520-4607 or [jvandyke100@yahoo.com](mailto:jvandyke100@yahoo.com).

**50-FT G16 BERTH.** For sale or lease. Pier 39. Best offer. Great bulkhead location on waterfront, newly dredged. (831) 345-5732 or [porisek@hotmail.com](mailto:porisek@hotmail.com).

**50-FT BERTH, SAN FRANCISCO.** Price negotiable. 50-ft berth for sale just in time for America's Cup. Slip J-16 @ San Francisco's Pier 39. (408) 954-1000 or [office@pestanaprops.com](mailto:office@pestanaprops.com).

**50-FT PRIME SLIP, PIER 39, SF** \$50,000. F-Dock, Slip 11, east side. Protected from wind. Close to gangway, showers and marina office. Covered parking across street with special rates for owners. Contact [scorch@tempest-edge.com](mailto:scorch@tempest-edge.com) or (559) 355-6572.

**DOCK FOR RENT, BRICKYARD COVE.** Point Richmond. \$350/obo. 32-ft dock for rent, separate entrance from house. (510) 236-2714 or [pennyacrowe@gmail.com](mailto:pennyacrowe@gmail.com).

**PRIVATE DOCK FOR BOAT.** Up to 85-ft. Point Richmond. \$6/foot. Near Richmond Yacht Club. Locked gate with 24/7 access. Power and water available. No liveaboard. Minimum \$400 per month. (510) 237-2020 or [emalonai@tyriscorp.com](mailto:emalonai@tyriscorp.com).

## CREW

**OFFSHORE SAILING VOYAGES.** Train aboard *Six String* 35-ft cutter just returned from circumnavigation of Pacific. Intensive one-on-one course conducted at sea. Sliding scale tuition based upon your experience and choice of destination. [www.rosewindcorporation.com](http://www.rosewindcorporation.com). (970) 635-0346 or [shellgamer@aol.com](mailto:shellgamer@aol.com).

**OFFSHORE INSTRUCTION.** John and Amanda Neal provide documented ocean passagemaking instruction aboard *Mahina Tiare III*, their Hallberg-Rassy 46, drawing on their combined 584,000 miles and 73 years experience. More info at [www.mahina.com](http://www.mahina.com) or (360) 378-6131.

## PERSONALS

**LOOKING FOR A TRAVELING COMPANION.** Who is ready for adventure. Lake Tahoe. I am 35 years old, fit and ready to share fun experiences with a like-minded woman. I will be traveling south to my home in southern Baja this November. In between surf trips and other fun activities, I am in the process of refitting my 49-ft ketch for an open-ended cruise. If this kind of lifestyle appeals to you, let's talk. Life is short, live it! Email [lasttoknow77@gmail.com](mailto:lasttoknow77@gmail.com).



**INTERNET FRAUD.** Recently, we've been getting another wave of reports of Internet scams, so we feel compelled to warn you once again about this unfortunate aspect of human nature. If somebody wants to buy your boat sight unseen, and suggests sending you a cashier's check for more than the asking price, trust your instincts. It is too good to be true. Usually they want you to cash the check and return the remainder to them for shipping costs. Then, much later, the bank informs you that the check was no good. We recommend that you don't even respond to the initial email inquiry. For more info on these cons, see: [www.craigslist.com/about/scams.html](http://www.craigslist.com/about/scams.html).

**QUALITY CRUISING SAILS FOR LESS!**



**MAINSAILS  
MIZZENS  
STAYSAILS  
HEADSAILS  
SPINNAKERS  
SAILCOVERS  
STRONGTRACK**

leesailsca@yahoo.com

(707) 386-2490

**SAILMAKER TO THE WORLD**

weatherguy.com

**Worldwide Marine Forecasts  
Cruising, Racing & Commercial  
Packages Starting at \$65.00 USD**

(866) 882-WXGY (9949) toll free  
(808) 291-WXGY (Mobile)  
(808) 254-2525 (Office)  
(808) 443-0889 (Fax)



970 N Kalaheo Ave  
Suite C-104  
Kailua, Hawaii 96734  
info@weatherguy.com

www.weatherguy.com



*A Sailor's  
Consignment  
Chandlery*

**NEW & USED BOAT GEAR**  
Open Tues.-Sat. 10 to 5 p.m.

**510-769-4858**

Located at Grand Marina

www.bluepelicanmarine.com



**got zinc?**

**boat bottom scrubbing & more...**

zinc replacements • propeller changes  
thru-hull inspection & replacement



415.331.SAIL www.gotzinc.com william@gotzinc.com

**JOBS WANTED**

**PART TIME WINTER WORK.** On or near salt water. Northern California Coast. From SF Bay north to Fort Bragg. Flexible schedule. Sailboat maintenance preferred or other maintenance, residential, land, etc. Qualifications: 37 years work experience, mostly in the timber industry. In the off season I worked in several different trades (almost a dozen). Cleared my own land and built my own house (and others). Do all my own boat work and it still floats, sails nice, too. (530) 596-3054 or jblundquistgis@gmail.com.

**JOB OPPORTUNITIES**

**SAILING INSTRUCTORS NEEDED.** Port of Redwood City Marina. Join the group of dedicated professional sailing instructors at Spinnaker Sailing in Redwood City. More info at http://spinnakersailing.com. Part time positions, flexible schedule, mid-week and weekends. Contact Rich or Bob at rich@spinnakersailing.com or (650) 363-1390.

**HARBORMASTER POSITION.** Richmond Yacht Club is pleased to announce an immediate opening for a full-time Harbormaster. The Harbormaster is responsible for the "hands on" management of the harbor and small boat yard. This includes safety, security, maintenance, repair, and space rental of the harbor, dry storage, and other assigned club facilities. Interested applicants should visit the Richmond Yacht Club website and click on the Harbormaster link to view the complete job posting and details for applying. www.richmondyc.org. Point Richmond, CA.

**RETAIL SALES.** Svendsen's Marine, a division of Svendsen's Boat Works, is seeking highly qualified retail salesperson(s). Candidates should have strong retail sales experience, willingness to stock inventory, assist customers and learn products of the marine industry. Candidates understanding marine systems and components, including sailboat hardware, plumbing, electrical parts, paints, solvents and coatings will be given preference. One or two weekend days required. Svendsen's Marine is a growing company with over 45 years of proven success. Full-time and part-time positions are available. Full-time positions include benefits, profit sharing, and other company perks. Svendsen's is an equal opportunity employer. No phone inquiries please. Please email resumes to: jobs@svendsens.com.



**MARINE TECHNICIAN.** Hirschfeld Yacht is a Bay Area leader in the sales, repair, service, installation, and customization of marine diesel engines and generators. We are looking for marine technicians to join our team. Minimum qualifications: 2+ years direct mechanical/electrical experience. Experience with gas and diesel engines ranging from 10-300hp, inboards and outboards. Experience with manufacturers such as Mercruiser, Mercury, Honda, Yamaha, Beta Marine, Yanmar, Perkins, Volvo, or Universal. Expertise in electrical systems with a solid understanding of electrical fundamentals. Clean background check. Must have a California driver's license and car/truck. Must have own tools and mobile tool kit/bag. Preferred qualifications: ABYC Certifications, manufacturer specific certifications, gas/diesel technology certifications, electrical certifications. For more information and to apply, email: hycbetawest@gmail.com.

**BUSINESS OPPORTUNITIES**



**LIVE THE DREAM \$250,000.** 30 year established charter business for sale. *Sadia Sea* operates out of St. John / U.S. Virgin Islands and is certified to hold 31 passengers. Contract with National Park Service to pick up hikers and many other partnerships. New paint, survey, lower decks and stability test summer 2012. www.sadiesea.com. Email for more details: sadieseacharters@gmail.com.



**PROPERTY/BUSINESS/VACATIONS.** In Brazil. Brazilian/US citizen living in Marin, has stunning sea-front property in "Angra dos Reis", South of Rio de Janeiro, Brazil. Looking for a property partner, for use and profit (when and if sold). The house (US\$320K) needs renovation and furniture (US\$80K). Gated, small condominium w/private beach. All clear and fully documented. Proportionally split use for vacations and (good) rental profit. Possible selling, especially after World Cup and 2017 Olympics. Google "Angra dos Reis, Brazil" for info. Contact Peter Borges at (415) 717-5589 or Peter@DocumentaSurveys.com.

**NEED CASH FAST?**



**Advertise your  
USED MARINE GEAR  
in our**

*Classy Classifieds*

**THIS STUFF SELLS FAST!**

**Deadline is the 18th at 5pm.  
See page 132 for details.**



**(510) 865-2511**

**www.helmsyacht.com**



**2008 SEAWIND 1160**



**PDQ 32 ALTAIR, 2000**

Lots of room. A great cruiser.



**CORSAIR TRIMARANS 24' to 37'**

Call for a test sail.

## 2002 NEWICK 50



*Traveller* is an incredible 50-ft offshore bluewater trimaran that allows you to sail fast, while also sailing level and comfortably. You will feel the power of the sails pull you along at wind speed, moving quickly in light winds. Yet, when things heat up, you can still feel confident and under control cruising around at 18 knots on autopilot. **\$379,000**

*Dealer for*

**Seawind Catamarans • Corsair Trimarans • Dragonfly Trimarans**

## ADVERTISERS' INDEX

AB Marine..... 6	BottomSiders..... 103	Emery Cove Yacht Harbor..... 41	Helmut's Marine Service..... 111	Loch Lomond Marina.... 91
Alameda Eyes Optometry ..... 59	Brisbane Marina ..... 43	Emeryville Marina ..... 87	Heritage Marine Insurance ..... 62	Makela Boatworks..... 87
Almar Marinas..... 33	CYOA Yacht Charters..... 115	Equipment Parts Sales..... 128	Heritage Yacht Sales... 144	Marchal Sailmakers.... 110
BVI Yacht Charters..... 114	Catamaran Access ..... 142	Essex Credit Corp..... 32	Hirschfeld Yachts ..... 48	Marina Bay Yacht Harbor..... 29
Bacon Sails & Marine Supplies ..... 43	Chandlery Yacht Sales, The..... 142	Farallone Yacht Sales..... 9	Hogin Sails..... 14	Marina de La Paz..... 63
Baja Ha-Ha Sponsors ..... 97, 98, 99	City Yachts..... 11	Flying Cloud Yachts ... 144	Hood Sails..... 25	Marina El Cid ..... 96
Baja Ha-Ha Beach Party ..... 63	Clipper Yacht Harbor.... 46	Forespar..... 102	Hotwire Enterprises..... 87	Marine Lube ..... 111
Bay Marine Boatworks ..... 27	Club Nautique ..... 16, 40	Fortman Marina..... 10	Hydrovane..... 96	Marine Outboard Company ..... 18
Bay Marine Diesel ..... 142	Conch Charters..... 114	Gentry's Kona Marina ..... 110	Intrepid Landing..... 50	Mariner's General Insurance ..... 86
Berkeley Marina..... 39	Cover Craft..... 48	Gianola Canvas Products ..... 45	Iverson's Design ..... 52	Maritime Institute..... 50
Berkeley Marine Center..... 49	Coyote Point Marina.... 47	Gold Coast Yachts ..... 52	JK3 Nautical Enterprises ..... 19	Marotta Yachts ..... 146
Blue Pelican ..... 140	Cruising Yachts ..... 7	gotzinc.com ..... 140	KISS-SSB/Radioteck ... 129	Mast Mate ..... 129
Blue Water Yacht Insurance ..... 55	Defender Industries..... 45	Grand Marina ..... 2	Kissinger Canvas..... 43	Mathiesen Marine ..... 110
Boat Yard at Grand Marina, The.... 21	DeWitt Studio ..... 109	Hansen Rigging ..... 51	KKMI - Brokerage..... 145	Mazatlan Marine Center/ La Paz Yachts ..... 47
	Downwind Marine..... 28	Harbor Island West Marina ..... 59	KKMI - Boatyard ..... 148	McDermott Costa Insurance ..... 61
	Doyle Sails ..... 55	Helms Yacht & Ship Brokers ..... 141	Lee Sails ..... 140	McGinnis Insurance..... 58
	Easom Rigging..... 82		List Marine Enterprises ..... 54	
	El Salvador Rally/ Bahia del Sol..... 131			

CONTINUED

**2008 HYLAS 46 • \$599,500**



- Fitted with the desirable deep keel (6' 6")
- Yanmar diesel engine with 50 hours
- In-boom Schaefer furling system
- Custom carbon fiber dodger/bimini built by Westerly Marine
- Antal electric winches
- Bottom painted October 2012
- One owner, in absolute pristine condition

*The Chandlery*  
YACHT SALES  
SANTA BARBARA  
**(805) 965-4538**  
[www.chandlery.com](http://www.chandlery.com)

***BAY MARINE DIESEL***

*Marine Inboard Diesel Repair  
Surveys • Personalized Instruction*

Cummins | Ford/Lehman | Hino | Perkins  
Universal | Westerbeke | Yanmar



**Marty Chin, Owner – (510) 435-8870**  
**Email: Baymarinediesel@comcast.net**

**THREE NEW LAGOON DESIGNS COMING**



LAGOON 400S2

This fall, Lagoon is introducing three new models to the family of world leading, world cruising catamarans.

As always, they come from the design group VPLP. We think VPLP has been the clear leader in high performance multihull design for many years. The amazing success of the Lagoon family is only one part of the proof.

For a close look at the great work of this group, go to their website at [www.vplp.fr](http://www.vplp.fr). If there's something familiar looking in there, maybe you've heard something about BMW Oracle.

Call us, or write, or watch the various sites for details about the new Lagoons!



[www.catamaranaccess.com](http://www.catamaranaccess.com)  
**(510) 469-3330 • (408) 828-7299**



**ADVERTISERS' INDEX – cont'd**

Minney's Yacht Surplus 128	Paradise Village..... 35	San Francisco Sailing Company ..... 15	Swi-Tec America ..... 103	Wedlock, Ramsay & Whiting Marine Surveyors ..... 111
Modern Sailing School & Club ..... 57	Passage Yachts..... 5	Sarana Cruising Guides..... 128	TMM Yacht Charters... 115	West Marine.... 20, 22, 24
Multihull Company, The ..... 143	Pineapple Sails ..... 3	Scandia Marine ..... 38	Trident Funding ..... 4	West Marine - Rigging.. 42
Napa Valley Marina..... 60	Port of Ensenada..... 126	Scanmar International .... 8	Twin Rivers Marine Insurance ..... 57	Westwind Precision Details ..... 53
New Era Yachts..... 143	Port of San Diego..... 31	Schoonmaker Point Marina ..... 30	Uli Boards ..... 128	Whale Point Marine Supply ..... 44
Norpac Yachts ..... 147	Punta Mita Beachfront Condos ..... 108	Seashine..... 83	Vallejo Marina ..... 49	White, Chris Designs .. 103
North Beach Marine Canvas ..... 53	Quickline..... 49	Seatech ..... 129	Ventura Harbor Boatyard..... 47	Wiest, Michael, Yacht Sales ..... 41
North Direct Sails..... 56	Raiatea Carenage Services ..... 127	South Beach Harbor ..... 34	Washkowitz, Jared A., Maritime Law Offices ..87	Yachtfinders/Windseakers ..... 45
North Sails ..... 23, 59	Ramp, The ..... 103	South Beach Riggers..... 53	weatherguy.com..... 140	
Oakland Yacht Club ..... 37, 58	Richardson Bay Marina ..... 51	Southbound Solar ..... 63		
Opequimar Marine Center..... 61	Sail California..... 12, 13	Spectra Watermakers . 110		
Outboard Motor Shop .. 60	Sail Warehouse, The .. 111	Starbuck Canvas ..... 129		
Owl Harbor Marina ..... 61	Sailrite Kits ..... 26	Start Line Strategies..... 87		
Oyster Cove Marina... 103	Sal's Inflatable Services ..... 83	Stem to Stern ..... 62		
Pacific Crest Canvas ..... 36	San Diego Boat Movers..... 54	Sterling Associates ..... 57		
Pacific Offshore Rigging..... 55	San Francisco Boat Works..... 51	Svendsen's Boat Works . 17		
		Svendsen's Marine ..... 83		
		Swedish Marine ..... 56		



*Happy Thanksgiving  
from the crew at  
Latitude 38*



## CALL TO TOUR THESE BOATS!



**42' PEARSON 424, 1981**  
This special boat is equipped for extensive cruising. Generator, inverter, watermaker and large sail inventory. Have a look and go cruising!  
Asking \$74,500



**56' FORMOSA, 1981**  
World famous cruising ketch, *Lost Soul*, outfitted and ready to go again. Ready for inspection at our docks and on our website.  
Beautiful!  
\$275,000



**57' ALDEN YAWL, 1931**  
Own a Master Mariners treasure.  
\$249,000



**50' VALIANT, 2001**  
An extraordinary yacht ready for your inspection. \$535,000

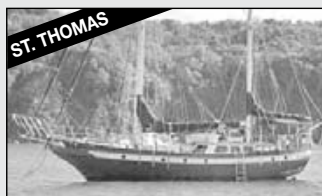

**51' FORMOSA, '79**  
Ready to cruise the Caribbean. Already there! \$145,000



**39' C&C CC, '85**  
Mexico ready, comfortable performance cruiser. \$69,900

39' CHB Trawler, '79 \$58,500 • 37' HERSHINE, '86 \$79,000 • 36' CATALINA, '85 \$35,000 • 30' CATALINA, '80 \$25,900 • 22' SANTANA, '75 \$3,750



2021 Alaska Packer Pl., Grand Marina, Alameda, CA 94501  
sales@newerayachts.com • daboatman@sbcglobal.net  
**(510) 523-5988 • www.newerayachts.com**



# THE MULTIHULL COMPANY

THE WORLD'S LEADER IN MULTIHULL SALES AND SERVICE

[www.multihullcompany.com](http://www.multihullcompany.com)

Let the world's largest international catamaran and trimaran brokerage, The Multihull Company, assist you with the purchase or sale of a multihull anywhere in the world.

The Multihull Company offers several distinct differences, from its pioneering buyer/broker program developed by founder Phillip Berman, himself a World Champion catamaran racer and author, to its international print advertisements that reach just the right buyers and sellers of catamarans, to its monthly newsletters that actually help readers understand the market, the latest trends in sailing, and even tackle the recent controversies about electric engines, helm station placement, daggerboards versus keels, etc., to our powerful online presence and social media know-how and U.S. and European boat show participation.

Visit us at [www.multihullcompany.com](http://www.multihullcompany.com) and see why The Multihull Company is truly the choice for sailors around the world. We offer even the casual browser the means to understand the market with expert videos, articles and an extensive selection of catamarans and trimarans listed for sale.

## FEATURED WEST COAST LISTINGS



**50' CATANA, 2008**  
Washington  
€700,000



**38' LEOPARD M3800, 2001**  
California  
\$199,900



**CATANA 471, 2001**  
Washington  
\$574,000



**42' FONTAINE PAJOT VENEZIA, 1995**  
Washington \$235,000



**34' GEMINI 105MC, 2008**  
Washington  
\$153,000



**36' CORSAIR C36, 2004**  
San Francisco, CA  
\$199,500

SAN FRANCISCO SEATTLE FT. LAUDERDALE CHARLESTON FRANCE TURKEY TRINIDAD TORTOLA ST. MARTIN KOREA

Office Phone: 215-508-2704 West Coast Office: 206-297-1151 email: [info@multihullcompany.com](mailto:info@multihullcompany.com)

# HERITAGE

Yacht Sales

Live your Dreams



DEALERS  
FOR CATALINA  
SAILBOATS AND  
HANS CHRISTIAN  
SAILBOATS

Long Beach-Naples  
Newport Beach  
San Diego  
Wilmington

866-569-2248  
877-389-2248  
760-402-3868  
877-599-2248  
Cell 310-995-9989

www.heritageyachts.com



54' Jeanneau DS, '06 \$479,000



50' Celestial PH, '00 \$320,000



47' Beneteau 473, '03 \$235,000



42' Catalina, '91 \$94,800



41' Hunter DS, '08 \$184,500



40' Hunter, '97 \$119,900



40' Lagoon, '10 \$425,000



39' Beneteau 393, '03 \$125,000



38' Hunter, '01 \$89,000



37' Hunter 376, '97 \$89,500



31' Pacific Seacraft, '07 \$159,500



28' Catalina, '98 \$39,800



MEMBER  
BoatWizard  
M.L.S.  
YachtWorld.com

## Flying Cloud Yachts



6400 Marina Drive  
Long Beach, CA 90803

Sail • BROKERS • Power  
www.flyingcloudyachts.net  
flyingcloud@verizon.net

Phone (562) 594-9716  
Fax (562) 594-0710



36' CATALINA SLOOP, '86 \$59,900



50' KETTENBURG, '64 \$95,000

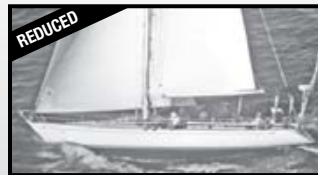

46' SWAN, '84 ~~\$229,000~~ \$199,000



46' CAL 2-46, '73 \$119,000



52' ENDEAVOUR CUTTER, '90 \$239,000



40' BABA, '80 \$120,000



43' MASON CUTTER, '79 \$124,500



34' PACIFIC SEACRAFT, '88 \$93,000



36' CATALINA MkII, '99 \$79,999



41' DRISCOLL BRUCE KING, '76 \$179,000



40' FORMULA CAT, '88 \$150,000



30' CATALINA TALL RIG, '88 \$29,900

APPROX. 100 LISTINGS ON OUR WEB SITE: www.flyingcloudyachts.net





**PASSENGER COI CHARTER VESSEL**



**PASSENGER COI CHARTER VESSEL**

To legally operate a charter with more than 6 passengers, a vessel must meet construction and inspection requirements of the USCG and be awarded a Certificate of Inspection (COI). Buying new or retrofitting can be prohibitively expensive. Purchasing an active COI vessel is the most cost-effective means to enter this market. These two vessels are ready to go, and each is self-supporting in its current business model. Call to learn more!

## Quality Yachts and Unique Opportunities



**HINCKLEY BERMUDA 40 MkII Yawl CB (1968)**  
*Invictus* is a classic Bill Tripp design in truly excellent condition. Many new updates.  
**\$119,000**



**BURGER 72 PILOTHOUSE YACHT (1964)**  
*Papagallo II's* luxurious "Onboard Nautical Events" attract intimate parties of two and celebrations of 40-60. Great SF Bay opportunity.  
**\$595,000**



**MUMM/FARR-OVINGTON 30 (1997)**  
*Trunk Monkey* is ready to join the SF Bay Class. Well built, spectacular racing history. Many, many upgrades.  
**\$65,000**



**SKIPPERLINER 63 (1996)**  
 Steel construction, twin CAT diesels, operates as "Delta Discovery Cruises" certified for Bay and Delta cruises with 83 passengers.  
**\$275,000**



**BALTIC 42 DP (1981)**  
*Why Not* is Doug Peterson's award-winning design for full comfort performance cruising. Motivated seller, Sausalito berth in very desirable location transfers with application approval. **\$75,000**



**CHUCK PAINE DESIGN/LYMAN MORSE 54 (2008)**  
*New Morning* is described by her designer Chuck Paine as one of the finest performing yachts with one of the most innovative interiors he's ever encountered. **\$1,475,000**



We are in the process of listing several exciting new yachts. Use the code to see our most current inventory.



[www.kkmi.com/yacht-sales](http://www.kkmi.com/yacht-sales)

(510) 236-6633 • fax: (510) 231-2355

[yachtsales@kkmi.com](mailto:yachtsales@kkmi.com)

530 W. Cutting Blvd., Pt. Richmond, CA 94804

The Bay Area's Premier Boatyard and Brokerage – An Unbeatable Combination

Now accepting quality new listings.

Contact Listing Manager  
[terri@kkmi.com](mailto:terri@kkmi.com)



# Marotta Yachts of Sausalito

Brokers of Fine Sail and Motor Yachts

415-331-6200 • info@marottayachts.com • www.marottayachts.com

See at: [www.marottayachts.com](http://www.marottayachts.com)

REDUCED



**47' CATALINA 470, 2008** Dark blue hulled beauty shows as new inside and out, only 50 hours on Yanmar. In-boom main, electric winches, bow thruster, custom hard dodger with Barrett Bonded glass. Transferable Sausalito Yacht Harbor slip. **\$349,000**

See at: [www.marottayachts.com](http://www.marottayachts.com)

REDUCED



**41' SCEPTRE CUTTER, 1985**  
Updated throughout, professionally maintained, transferable Sausalito Yacht Harbor slip. **\$174,900**

See at: [www.marottayachts.com](http://www.marottayachts.com)

REDUCED



**48' ISLANDER SLOOP, 1985**  
Pacem has had only two long-term owners since new, and shows absolutely beautifully today. New sails. **\$159,000**

See at: [www.marottayachts.com](http://www.marottayachts.com)

NEW LISTING



**52' CUSTOM COLD-MOLDED SCHOONER, 1999** Her keel was laid in '72, she then sat unfinished in covered shed until current owners discovered her in '95; meticulously finishing her out before & after '96 launch; then christened/documentated in '99. **\$149,000**

See at: [www.marottayachts.com](http://www.marottayachts.com)



**38' TA SHING PANDA, 1983**  
Gary Grant-designed classic beauty with brightwork and interior showing MUCH newer than her age. New interior upholstery and foam. Sails well, will make a perfect cruiser. **\$129,900**

See at: [www.marottayachts.com](http://www.marottayachts.com)



**36' UNION POLARIS, 1981** Only one owner since new, *Phantom* has never been cruised, extensively upgraded over the years, and is bristol inside/out. Must be seen to be appreciated, a tender for anyone in the market for a traditional cruiser. **\$99,000**

See at: [www.marottayachts.com](http://www.marottayachts.com)



**53' ISLANDER, 1979**  
Over \$100,000 spent over past several years on this vessel. Rewired, new fuel tanks, extensive upgrades. Owner is motivated to sell IMMEDIATELY. **\$79,000**

See at: [www.marottayachts.com](http://www.marottayachts.com)



**37' HUNTER LEGEND 37.5, 1993** 37.5 was one of Hunter's most popular designs ever and this particular low-time example is very clean inside and out, competitively priced and lying in Sausalito Yacht Harbor slip that's potentially transferable. **\$67,000**

See at: [www.marottayachts.com](http://www.marottayachts.com)



**33' WAUQUIEZ, 1984** Classic European sloop shows much newer than actual age – interior in particular shows as new. Major refit '97 included a much more powerful 30 hp diesel, B&G electronics, Harken roller furler, sails, heavy-duty dodger, etc. **\$59,000**

See at: [www.marottayachts.com](http://www.marottayachts.com)

REDUCED



**37' TAYANA, 1977**  
Nice example of a very popular model with exterior canvas and brightwork in good shape. The Perkins 4-108 diesel runs like a top, and the interior shows well. **\$49,900**

See at: [www.marottayachts.com](http://www.marottayachts.com)



**30' FORTUNE PILOTHOUSE CUTTER, 1978** This charming custom pilothouse feels WAY bigger than 30"! She also has much new equipment (including new Isuzu diesel installed in '95), shows pride of ownership throughout, and is a must-see. **\$43,500**

See at: [www.marottayachts.com](http://www.marottayachts.com)

REDUCED



**45' STARRATT & JENKS, 1977**  
Nice aft cockpit sloop with new Yanmar diesel (\$30,000 project). Great value cruiser or liveaboard. **\$39,000**

# NORPAC YACHTS

1150 Brickyard Cove Rd., B9, Pt. Richmond, CA 94801

(510) 232-7200 • FAX (510) 232-7202

email: [info@norpacyachts.com](mailto:info@norpacyachts.com)

**WE NEED  
MORE BOATS...  
BUYERS ARE CALLING!  
LIST YOUR BOAT  
NOW...  
IT'S FREE!**



**43' STEPHENS CLASSIC** Raised Deck Express Cruiser, 1931. Covered berth kept & beautiful. Charming Gatsby-era yachting in grand style. She's a work of art! Ready to go & have fun now! Twin Chryslers, more! **\$115,000**



**REDUCED!**

**44' STEEL** Canoe-stern cutter by Geo. Buhler/Fred Lagier & Sons. John Deere diesel. Stout steel construction. Awesome bluewater cruiser built to go to sea and stay there. Radar, GPS, etc. Here's your world beater! Asking **\$62,950**



**OWNER MAY FINANCE!**

**48' GRAND BANKS** Trawler LRC. Aft master S/R, twin diesel, FB & PH helms, classic mahogany in BEAUTIFUL condition. Onan, fully loaded galley, 3 heads, shower & tub, inflatable dinghy w/ motor, swim platform, steady sails, radar, MORE! Asking **\$99,950**



**REDUCED!**

**48' DUTCH CANAL BOAT** by deVries Lentsch. Steel. Unique, comfortable cruiser for Bay/Delta. Diesel, tub, galley, fireplace, salon, convertible aft enclosure, beautiful decor, MORE! LIVEABOARD. A GEM! Now asking **\$144,000**



**27' CANADIAN SAILCRAFT CS-27** Low hours Yanmar diesel. Exceptionally well built & just finished major refit-refinish in & out. Absolutely beautiful, this boat looks new! Roller furling, self-tailing winches, new rigging & MORE. Outstanding value. Asking **\$17,950**



**MAKE OFFER!**

**35' ERICSON MkII** Sloop. Near new standing and running rigging, and sails by Quantum. Profound roller furling—all almost new, solid example of a great Bruce King design. Excellent cruiser, 1/B, 13 Barient winches, wheel, 2 spinn, retrig., shower, double spreader rig and MORE! **\$24,950/Offers**



**ULTIMATE AMERICA'S CUP VIEWING PLATFORM!**

## 100' MEGA SLOOP

Big, beautiful; loaded with everything you might want for comfort, convenience and performance. 26+ knots under sail. 23' beam, 250 hp Cummins diesel aux, and much more.

Asking **\$695,000**



**40' DUFOUR PERFORMANCE CRUISER** Full electronics, roller furling, dodger, fine sail inventory, cruise equipped. Fast, comfortable, in beautiful condition and MORE! Located in Southern California, she's a MUST SEE! Asking **\$159,500**



**35' SPARKMAN & STEPHENS** Center Cockpit Sloop. Diesel, aft stateroom, hard (fully enclosable) dodger, good sail inventory, wheel, extra strong fiberglass construction, well found quality cruising boat. Asking **\$28,950**



**49' ROSBOROUGH WINDJAMMER SCHOONER** Stoutly built in Nova Scotia in 1980 of bronze-fastened white oak. 57' LOA; 13.5' beam. Loaded with character. Built to go to sea & stay there. Roomy, seaworthy design. Center cockpit, large aft strm, MORE! Asking **\$49,500**



**PERFORMANCE**

**40' X-YACHTS X-119 HIGH-PERFORMANCE** sloop. Renowned Danish performance cruiser/racer. Loaded with gear and high tech sails. Proven bluewater cruiser and race winner. **\$109,000**



**LIVE/CRUISE**

**46' ISLAND TRADER MOTORSAILER KETCH** F/G, diesel, in/out wheel steering, queen aft plus double and single staterooms, two enclosed heads with showers and tub, AIS transponder, radar, AP, roomy, more! **\$89,950**



**35' TIARA 3500 XL EXPRESS CRUISER** Comfort, elegance & performance in one ultra-clean package. Twin 502 XL Crusaders. Roomy & luxurious, these powerhouses are well respected for their fit, finish & overall quality in the powerboat community & elsewhere. Asking **\$114,000**

**PICTURE YOUR BOAT HERE IT'S FREE!**



**BARGAIN!**

**40' VALIANT CUTTER** Great blue water cruising design that changed cruisers forever. Loaded with cruising gear, color radar, R/F, plotter, nav station, private staterooms, and MORE! A big, strong, performance world cruiser. Asking **\$74,950**



**28' SOUTHERN CROSS** Cutter. Famous top quality pocket cruiser designed by renowned naval architect Thomas Gilmer. Diesel, double-ender, FG. Known for seaworthiness and beauty, these fine craft are rare on the West Coast. A great opportunity. Asking **\$17,950**



**READY TO CRUISE TO ALASKA!**

**46' LAKE UNION CLASSIC CRUISER**, 1930. Restored/rebuilt, excellent cond., new dsls, new genset, rewired/reframed/refastened, radar, MORE! She could cruise to Seattle tomorrow. Premium covered Marin berth. Dsl cabin heat. Great liveaboard/cruiser. Asking **\$69,995**



**40' NEWPORTER** Ketch. "Ack" Ackerman's wonderful seaworthy and comfortable design in beautiful condition. 54 HP Isuzu diesel, 2 helms (wheel on pedestal & in pilothouse) radar, AP, cabin heat. Well set up for cruising & ready to go. Asking **\$49,950**



**REDUCED!**

**58' ALDEN BOOTHBAY EXPLORER** Motorsailer Ketch. Aft stateroom, dsl, genset, AC, heat & MORE! Famous bluewater cruiser meant to go to sea & stay there. Excellent layout, fantastic potential. Asking **\$198,500**

PLEASE SEE [www.norpacyachts.com](http://www.norpacyachts.com) and/or [www.yachtworld.com/norpacyachts](http://www.yachtworld.com/norpacyachts) for MORE BOATS

**CALL (510) 232-7200 OR TOLL FREE (877) 444-5087 OR CALL GLENN DIRECTLY AT (415) 637-1181 FOR INFORMATION & APPOINTMENTS**



*It's fall, what smells better...  
freshly carved turkey or wood?*

HOME

SERVICES

LOCATIONS

STORE

YACHT SALES

- GENERAL YARD
- HAULS & LOADING
- BOTTOM PAINTING & REPAIR
- FINISH PAINTING & DETAILING
- GEL COAT & FIBERGLASS
- WELDING & FABRICATION
- WOODWORKING & CABINETRY
- SYSTEMS & EQUIPMENT
- RIGGING
- ENGINES
- ELECTRONICS

WOODWORKING & CABINETRY



In addition to offering the best value in routine shipyard work, such as bottom painting, KKMI also employs world-class wooden boat shipwrights. From cabinetry to teak decks the craftsmen located in Pt. Richmond and Sausalito can create a wooden masterpiece or repair one. Check out our Facebook page for some recent projects.

- ▶ Teak decks
- ▶ Wooden spars
- ▶ Custom cabinetry
- ▶ Repairs
- ▶ Yacht restorations



**WHAT A SIGHT ...** in the past month we've seen some pretty spectacular sailing yachts on the Bay, and I dare say... of the likes never witnessed before. The spectrum of yachts couldn't have been more diverse - from ultra modern AC 45's to classic wooden yachts. What is common between these two is both require skilled craftsmen to keep them afloat. Certainly when it comes to traditional yachts built of wood, KKMI is the only company on the Bay with a portfolio of famous yachts such as: Pursuit, Yankee, Brigadoon, Santana, and most recently, Dorade. If you own a classic power or sailboat, you owe it to yourself and your fine yacht to visit KKMI, where wood is part of their culture.

PT. RICHMOND (510) 235-5564

SAUSALITO (415) 332-5564

WWW.KKMI.COM