

# Latitude 38

VOLUME 416 February 2012

WE GO WHERE THE WIND BLOWS

Latitude 38

FEBRUARY 2012

VOLUME 416

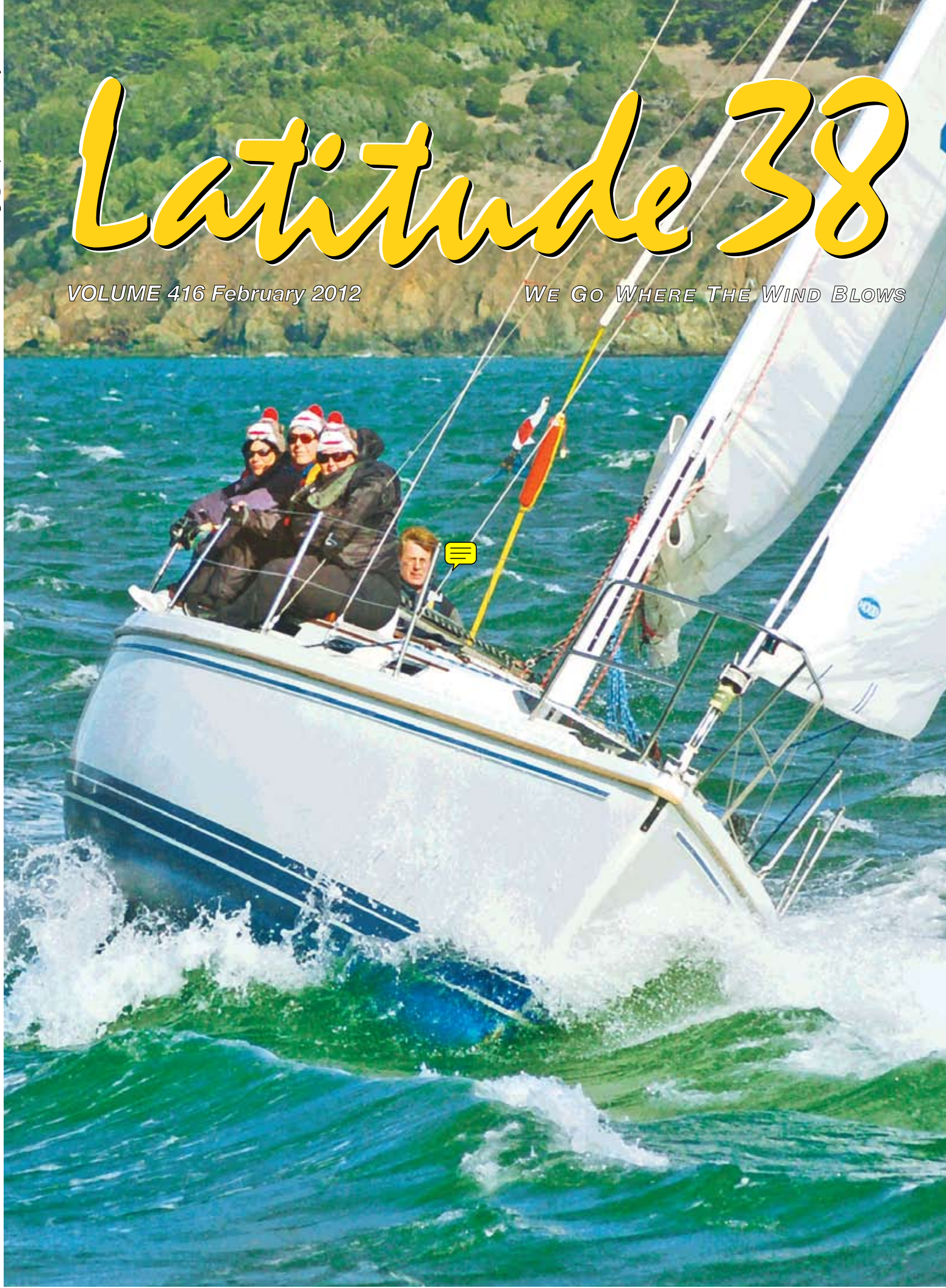





## THE ALAMEDA ESTUARY

There's no better way to end a day of sailing on the Bay than with a leisurely trip down the estuary, with the wind at your back. Sails flaked and bound, and all canvas already securely in place when you dock, you'll be ready to kick back with a drink and watch the sun set. No fuss, no muss.

## GRAND MARINA

There's no better place to end a day sailing the Bay. Come check us out.

*We currently have berthing available up to 45-ft.*

- Prime deep water concrete slips in a variety of sizes
- Great Estuary location at the heart of the beautiful Alameda Island
- Complete bathroom and shower facility, heated and tiled
- FREE pump out station open 24/7
- Full Service Marine Center and haul out facility
- Free parking
- Free WiFi on site!
- And much more...

DIRECTORY of GRAND MARINA TENANTS	
Blue Pelican Marine.....	149
Boat Yard at Grand Marina, The ..	23
Marchal Sailmakers .....	119
New Era Yachts .....	151
Pacific Crest Canvas.....	30
Pacific Yacht Imports	
UK-Halsey Sailmakers	



**GRAND MARINA**

ANDERSON-ENCINAL

**(510) 865-1200**

Leasing Office Open Daily  
2099 Grand Street, Alameda, CA 94501  
[www.grandmarina.com](http://www.grandmarina.com)

# The Difference Is No Illusion

What do world caliber sailors dream about: winning races, setting records and ...maybe even cruising.

Stan and Sally Honey race on some of the most state-of-the-art racing sailboats ever built. They win major events. They set records. And they race - and cruise - their own boat, a Cal 40, *Illusion*.

Sally was a sailmaker for many years, owning and operating The Spinnaker Shop and building quality racing and cruising sails. So when she and Stan wanted a new jib for *Illusion* they knew exactly what they wanted: a working jib that even has slab reefing with a zipper closure. And they knew that they could rely on Pineapple Sails to match their demands. The result: a special, versatile jib designed to perform, both racing and cruising.

Every sail we build - and they are all built start to finish right here in Alameda - receives the same singular attention. The excellence in design, materials, and workmanship is no illusion.

Give us a call - better yet, stop by to discuss sails for your boat and get a quote.



*Illusion*\*

YOUR DEALER FOR: Musto foul weather gear, Dubarry footwear and Headfoil 2

Sails in need of repair may be dropped off at:  
West Marine in Oakland, Alameda, or Richmond.

\*Powered by Pineapples



## **PINEAPPLE SAILS**

Phone (510) 522-2200

Fax (510) 522-7700

[www.pineapplesails.com](http://www.pineapplesails.com)

2526 Blanding Ave., Alameda, California 94501

# BOAT LOANS

*from*



Trident Funding

*"a fresh  
approach  
from people  
you can trust"*

In Northern California call  
**JOAN BURLEIGH**  
**(800) 690-7770**

In Southern California call  
**JEFF LONG**  
**MARGE BROOKSHIRE**  
**(888) 883-8634**

[www.tridentfunding.com](http://www.tridentfunding.com)

## CONTENTS

subscriptions	6
calendar	8
letters	16
sightings	60
year in preview	74
remembering rob	78
baja bash options	84
a whale of a tale	92
so pac strategies	98
america's cup insider's guide	102
max ebb: weird tales	108
the racing sheet	112
world of chartering	120
changes in latitudes	126
classy classifieds	142
advertisers' index	149
brokerage	151

Cover: It's not a coincidence that 'reef' is spelled almost like 'relief', so when you need relief from being overpowered, reef early and often.

Photo: *Latitude/Andy*

Copyright 2012 Latitude 38 Publishing, LLC

*Latitude 38* welcomes editorial contributions in the form of stories, anecdotes, photographs – anything but poems, please; we gotta draw the line somewhere. Articles with the best chance at publication must 1) pertain to a West Coast or universal sailing audience, 2) be accompanied by a variety of pertinent, in-focus digital images (preferable) or color or black and white prints with identification of all boats, situations and people therein; and 3) be legible. These days, we prefer to receive both text and photos electronically, but if you send by mail, anything you want back must be accompanied by a self-addressed, stamped envelope. **Submissions not accompanied by an SASE will not be returned.** We also advise that you not send original photographs or negatives unless we specifically request them; copies will work just fine. Notification time varies with our workload, but generally runs four to six weeks. Please don't contact us before then by phone or mail. Send all submissions to [editorial@latitude38.com](mailto:editorial@latitude38.com), or mail to Latitude 38 editorial department, 15 Locust Ave., Mill Valley, CA 94941. For more specific information, request writers' guidelines from the above address or see [www.latitude38.com/writers.html](http://www.latitude38.com/writers.html).



## SELECT BROKERAGE



44' Spencer S-1330, 1976 \$111,000



Island Packet 45, 1999 \$235,000



Island Packet 380, 1999 \$228,000

### SAIL

54'	Moody	2001	\$633,000
47'	Beneteau 473	2005	279,000
47'	Vagabond	1983	185,000
45'	Island Packet 465	2008	475,000
45'	Island Packet	1999	235,000
44'	Spencer S-1330	1976	111,000
41'	Dehler DS	1998	169,900
41'	Tartan 4100	1996	215,000
40'	Beneteau	2009	208,500
40'	Beneteau	2008	185,000
39'	Beneteau 393	2006	139,000
39'	Cal Mk II	1980	57,000
38'	Island Packet 380	1999	228,000
38'	Island Packet 38	1993	119,000
38'	Ericson 38-200	1988	69,000
37'	Tartan 3700	2002	195,000
37'	Tartan 37	1982	65,000
37'	Island Packet 370 cutter	2004	293,000
37'	Pacific Seacraft yawl	1984	129,000
36'	Hunter sloop	2004	110,000
36'	Beneteau 361	2000	99,500
36'	CS Merlin	1988	52,000
36'	Pearson 36-II	1985	57,900
36'	Islander	1977	49,500
35'	Dehler 35 cws	1996	82,000
34'	C&B Marine Tiffany Jayne	1982	29,000
33'	Hunter 33.5 sloop	1992	40,000
33'	Hunter 33 sloop	2005	89,000
33'	Yamaha	1979	22,000
32'	Beneteau 323	2006	90,000
32'	J/32	1997	84,900
32'	Westail	1976	64,400
30'	Beneteau First 305	1988	35,000
28'	Alerion Express	2008	114,000
28'	Alerion Express	2002	87,000
24'	Corsair Sprint 750	2008	55,000

### POWER

61'	Mikelson SFPH	2002	990,000
53'	Navigator CPMY	1998	259,000
42'	Californian aft cabin MY	1987	99,500
38'	Pearson True North	2007	327,500
29'	Shamrock 290 walkaround	2001	120,000

**GET RESULTS –  
LIST WITH US!**

1220 Brickyard Cove Rd  
Pt. Richmond, CA  
p: 510-236-2633  
f: 510-234-0118

[www.passageyachts.com](http://www.passageyachts.com)

## Winter Show Prices in Effect! Save thousands on a new 2012 Beneteau or Island Packet



**Oceanis 37**

Order a new Beneteau 37 with Simrad electronics, Simrad VHF, electric windlass, gennaker gear, furling main and furling headsail, deluxe interior detailing and more.

**Sail Away for \$180,530**  
Save over \$14,000



**Oceanis 41**

Order a new Beneteau 41 with full Simrad electronics, Simrad VHF, electric windlass, electric winch, freezer and refrigeration, furling main and furling headsail, stereo, deluxe interior detailing and more.

**Sail Away for \$242,500**  
Save over \$14,000



**Oceanis 45**

Order a new Beneteau 45 with full Simrad electronics, Simrad VHF, electric windlass, electric winch, freezer and refrigeration, furling main and furling headsail, stereo, bow thruster, deluxe interior detailing and more.

**Sail Away for \$324,000**  
Save over \$16,000



**Sense 43**

Take delivery of a luxurious Sense 43 with full Raymarine electronics, bow thruster, electric windlass, electric winches, freezer and refrigeration, furling main, furling headsail, stereo, detailing and more.

**Sail Away for \$354,000**  
Save over \$31,000



**First 30**

Take advantage of this blow-out pricing on our stock First 30. Save thousands on this new boat. Compare at \$187,000 for an ordered boat. Doyle sails, electronics, full interior, shorepower and more.

**Sail Away for \$164,000**  
Save over \$12,000

## March Calendar of Events

**Open Boat Weekend**  
Alameda ■ February 11-12  
**Boat Fest** ■ March 1-4

**Looking for a  
boat partnership?  
Please call for details  
about our new  
Passage Partners Program.**



1070 Marina Village Pkwy  
Suite #101  
Alameda, CA  
p: 510-864-3000  
f: 510-337-0565

# BLUE WATER YACHT INSURANCE

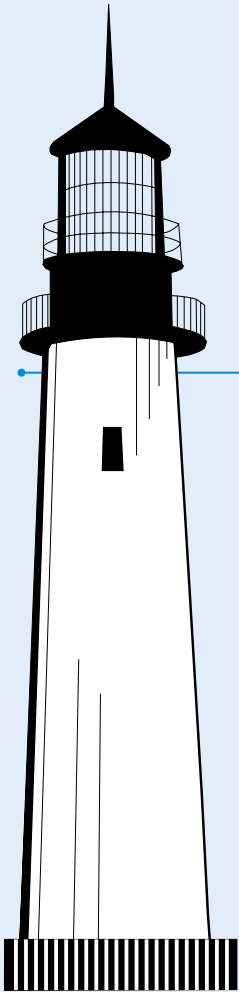

Blue Water Yacht Insurance covers more active cruising boats than any other marine insurance agency in the Western Hemisphere, and is the leading innovator of insurance products for the offshore sailor.

## Our Insurance Programs Provide:

- Crew of two anywhere
- Worldwide Navigation
- Hawaii
- Caribbean
- South Pacific
- Mexico
- Charter Boats
- Multihulls
- Liveboards
- Racing Boats

## Quality Rated Insurance Companies

Boats aged 1 to 40 years • "Agreed Value"  
"All Risks" • "New for Old" replacement partial losses  
Hulls valued \$50,000 to \$25,000,000

## Worldwide Health Insurance

International and USA health insurance plans at affordable prices.



BLUE WATER  
INSURANCE

Call Toll Free  
**(866) 463-0167**  
Fax: (866) 795-3707  
sales@bluewaterinsurance.com

Quote requests  
Visit our website

[www.bluewaterinsurance.com](http://www.bluewaterinsurance.com)

# SUBSCRIPTIONS

**YOU CAN ALSO GO TO  
www.latitude38.com  
TO PAY FOR YOUR  
SUBSCRIPTION  
ONLINE**

## eBooks email list. *Free!*

See [www.latitude38.com](http://www.latitude38.com) to download the entire magazine for free! Our eBooks are in PDF format, easy to use with Adobe Reader, and also available in Issuu format.

Email: \_\_\_\_\_

*Please allow 4-6 weeks to process changes/additions, plus delivery time.*

Enclosed \$36 for one year Third Class Postage (Delivery time 2-3 weeks; Postal Service will not forward third class; make address changes with us in writing.)

Enclosed \$55 for one year First Class Postage (Delivery time 2-3 days.)

Third Class Renewal  First Class Renewal *(current subs. only!)*

Gift Subscription

Card to

read from: \_\_\_\_\_

*NOTE: FPO/APO (military), Canada, Mexico, and subscriptions going to a correctional facility are first class only. Sorry, no foreign subscriptions.*

Name \_\_\_\_\_

Address \_\_\_\_\_

City \_\_\_\_\_

State \_\_\_\_\_

Zip \_\_\_\_\_

Phone: ( ) \_\_\_\_\_

Email: \_\_\_\_\_

## CREDIT CARD INFORMATION

Min. Charge \$12

MASTERCARD

VISA

AMERICAN EXPRESS

Number: \_\_\_\_\_

Exp.: \_\_\_\_\_

csv: \_\_\_\_\_

## INDIVIDUAL ISSUE ORDERS

Current issue = \$6 ea.

Back Issues = \$7 ea.

MONTH/YEAR: \_\_\_\_\_

## DISTRIBUTION

We have a marine-oriented business/yacht club in California which will distribute copies of *Latitude 38*. (Please fill out your name and address and mail it to the address below. Distribution will be supplied upon approval.)

Please send me further information for distribution outside California

Business Name \_\_\_\_\_

Type of Business \_\_\_\_\_

Address \_\_\_\_\_

City \_\_\_\_\_

State \_\_\_\_\_

Zip \_\_\_\_\_

County \_\_\_\_\_

Phone Number \_\_\_\_\_

# Latitude 38

"we go where the wind blows"

Publisher/Exec. Editor ..... Richard Spindler ..... richard@latitude38.com ..... ext. 111  
Associate Publisher..... John Arndt..... john@latitude38.com ..... ext. 108  
Managing Editor ..... Andy Turpin ..... andy@latitude38.com ..... ext. 112  
Editor..... LaDonna Bubak..... ladonna@latitude38.com ..... ext. 109  
Racing Desk ..... razing@latitude38.com ..... ext. 105  
Contributing Editors ..... John Riise, Paul Kamen  
Advertising Sales ..... John Arndt..... john@latitude38.com ..... ext. 108  
Advertising Sales ..... Mike Zwiebach ..... mikez@latitude38.com ..... ext. 107  
General Manager ..... Colleen Levine ..... colleen@latitude38.com ..... ext. 102  
Production/Web ..... Christine Weaver ..... chris@latitude38.com ..... ext. 103  
Production/Photos..... Annie Bates-Winship ..... annie@latitude38.com ..... ext. 106  
Bookkeeping..... Penny Clayton..... penny@latitude38.com ..... ext. 101

Directions to our office..... press 4  
Subscriptions..... press 1,4  
Classifieds ..... class@latitude38.com ..... press 1,1  
Distribution ..... distribution@latitude38.com ..... press 1,5  
Editorial ..... editorial@latitude38.com ..... press 1,6  
Calendar ..... calendar@latitude38.com  
Other email..... general@latitude38.com



[www.latitude38.com](http://www.latitude38.com)

15 Locust Avenue, Mill Valley, CA 94941  
Ph: (415) 383-8200 Fax: (415) 383-5816







Northern California

# Boat Fest

Marina Village Yacht Harbor  
Alameda, California

**March 1-4 2012**

Thu & Fri: 12-5 • Sat & Sun: 11-5

- Power & Sail
- New & Used
- 100+ Yachts For Sale
- Seminars
- Marine Exhibits
- Music & Food

**Exclusive Dealer for Jeanneau, Hunter and Caliber Yachts**  
See over 100 new and used yacht listings at [www.CruisingYachts.net](http://www.CruisingYachts.net)

**2012 JEANNEAU 379**  
*Boat of the Year Award Winner!*

**2012 HUNTER e33**  
*Boat of the Year Award Winner!*

1 available

**2011 HUNTER 50 AC**  
*SALE PRICE \$397K*

1 available

**2011 HUNTER 45DS**  
*SALE PRICE \$259K*

1 available

**2011 JEANNEAU 42DS**  
*SALE PRICE \$259K*

**2005 JEANNEAU 49**  
*Reduced \$287,000*

Sistership

**2007 JEANNEAU 49DS**  
*Asking \$375,000*

**1979 AMEL MARU 46**  
*New Listing \$168,900*

**2007 HUNTER 44 DS**  
*Reduced \$209,000*

Sistership

**2007 JEANNEAU 42DS**  
*Now Asking \$229,900*

**2007 DELPHIA 40.3**  
*Clean! Asking \$149K*

**'87 FAIRWEATHER 39**  
*Asking \$115,000*

**2005 BENETEAU 373**  
*Reduced \$124,500*

**1994 HUNTER 29.5**  
*Asking \$32,450*

**Come aboard our 2012 Jeanneau 409 in Clipper Yacht Harbor.**  
**California's largest used yacht broker with 6 waterfront locations.**

San Diego  
(619) 681-0633  
Newport Beach  
(949) 650-7245

Alameda  
(510) 521-1327  
Sausalito  
(415) 332-3181

Marina del Rey  
(310) 822-9400  
Oxnard  
(805) 791-2082

**WWW.CRUISINGYACHTS.NET**

# CALENDAR

## Non-Race

**Jan. 27-Feb. 5** — Seattle Boat Show Indoors + Afloat at CenturyLink Field & Event Center and South Lake Union. The largest boat show on the West Coast. Visit [www.seattleboatshow.com](http://www.seattleboatshow.com) for more info.

**Feb. 1-29** — Wednesday Yachting Luncheon Series at St. Francis YC, 12-2 p.m. Enjoy lunch and a dynamic speaker each Wednesday for about \$20. All YCs' members welcome. More info under the 'Events' tab at [www.stfyc.com](http://www.stfyc.com).

**Feb. 2, 1901** — Passenger ship *Rio de Janeiro* struck Mile Rock off San Francisco's Golden Gate and sank, taking 128 of the 209 lives aboard with her.

**Feb. 2** — Club Nautique's Winter Seminar Series continues with 'Racing Tactics, Tips & Tricks' by Kame Richards in Alameda, 6-8 p.m. Seminars run at the same time at alternating locations (A=Alameda, S=Sausalito). \$10 members/\$15 non-members. **2/16**: An Evening with Jim DeWitt (S); **3/1**: 'Overboard Recovery' by Joe Brandt (A); **3/15**: 'Onboard Cooking with Caribbean Style' by Master Chef Chuck Dell'Ario. Info, (510) 865-4700 or [www.clubnautique.net](http://www.clubnautique.net).

**Feb. 4** — 23rd Annual Women's Sailing Convention at Bahia Corinthian YC in Corona del Mar, \$175. Info, [www.scya.org](http://www.scya.org).

**Feb. 4 & 5** — Baja Ha-Ha Assistant Poobah 'Banjo Andy' Turpin will present Ha-Ha and Pacific Puddle Jump seminars back-to-back on both days at the Seattle Boat Show. See [www.seattleboatshow.com](http://www.seattleboatshow.com) for times.

**Feb. 5** — Chinese Whispers: Golden Gate, a storytelling project highlighting folk memories about the maritime aspects of Chinese immigrants on the Bay. Held on *Eureka* at SF Maritime National Historical Park's Hyde St. Pier, 3-5 p.m. Free. Info, [www.chinese-whispers.org](http://www.chinese-whispers.org).

**Feb. 5-26** — Free sailing at Pier 40 every Sunday courtesy of BAADS. Info, (415) 281-0212 or [www.baads.org](http://www.baads.org).

**Feb. 7** — Adventure Ocean Quest film at the Bay Model in Sausalito, 6-7 p.m. German filmmakers explore the mysteries of our oceans. Donations welcome. Info, (415) 332-3871.

**Feb. 7** — Sail under a full moon on a Tuesday night.

**Feb. 9** — Single sailors of all skill levels are invited to the Single Sailors Association monthly meeting at Ballena Bay YC, 7:30 p.m. Info, [www.singlesailors.org](http://www.singlesailors.org) or (510) 233-1064.

**Feb. 9** — The America's Cup & the U.S. Coast Guard presentation at Encinal YC, 7 p.m. Learn about the racing areas, safety zone restrictions and more. Free. Info, [rearcommandore@encinal.org](mailto:rearcommandore@encinal.org).

**Feb. 10-22** — *Lady Washington* and *Hawaiian Chieftain* kick off their Northern California tour in Oakland with tours, educational programs, and Adventure sails. **2/24-3/7**: Redwood City; **3/9-19**: San Francisco; **3/21-4/2**: Sausalito; **4/4-9**: Bodega Bay; **4/12-18**: Eureka; **4/20-30**: Crescent City. See [www.historicalseaport.org](http://www.historicalseaport.org) for a full schedule.

**Feb. 11** — North U. Trim Tour is a one-day course teaching the latest in sail trim. The first seminar is in Marina del Rey at Del Rey YC. All seminars run 9 a.m.-4:30 p.m. **2/25**: San Francisco; **3/25**: Anacortes, WA; **3/31**: Seattle, WA (Cruising & Seamanship Seminar); **3/31**: Vancouver, BC; **4/1**: Seattle, WA; **4/1**: Vancouver, BC (Cruising & Seamanship); **4/21**: Coos Bay, OR. \$85-115. Info, [www.northu.com](http://www.northu.com).

**Feb. 11** — US Sailing Race Management seminar at Encinal YC. Limited space. \$50 for US Sailing members, \$90 for others. Info, (510) 459-5566 or [lwestland@tricommercial.com](mailto:lwestland@tricommercial.com).

**Feb. 12** — The final installment of 'So You Wanna Crew on a Sailboat' seminar series at San Jose West Marine, 1-2 p.m. Info, (408) 246-1147.

**Feb. 13-20** — Lake Havasu Pocket Cruiser Rendezvous. A



GET YOUR FREE  
2012 SAILRITE CATALOG\*

[www.sailrite.com/catalog-request](http://www.sailrite.com/catalog-request)

800.348.2769

Sails | Canvas | Hardware | Tools | Kits

\*Free to U.S. mailing addresses only.



# FARALLONE YACHT SALES

Catalina Yachts

CUTWATER

Ranger Tugs

TARTAN YACHTS



Exclusive Northern California dealer for Catalina and Tartan sailboats, including the 2012 **Boat of the Year Tartan 4000**, and proud California dealer of Ranger Tugs and Cutwater Boats. Visit [www.faralloneyachts.com](http://www.faralloneyachts.com) for more information, including photos and specs on the quality pre-owned boats in our brokerage.



BOAT FEST MARCH 1-4 • LIST WITH US! • OPEN BOAT WEEKEND FEBRUARY 11-12



1999 CATALINA 470 *Latitude Adjustment*  
\$225,000



2005 CATALINA 350 *Memento*  
\$133,000



2006 CARVER SUPER SPORT *Too Fanautical*  
\$149,000

**New Catalina Yachts in Stock**

- Catalina 445, 2010 **BIG DISCOUNTS!**
- Catalina 355, 2011 **AT OUR DOCKS NOW!**
- Preowned Catalina Yachts at Our Docks**
- Catalina 470, 2006 ..... **NEW LISTING!** \$329,500
- Catalina 470, 1999 ..... 225,000
- Catalina Morgan 440, 2005..... **NEW LISTING!** 290,000
- Catalina 42, 2000 ..... **NEW LISTING!** 169,900
- Catalina 400 MkII, 2001 ..... 159,000
- Catalina 400, 1995 ..... **NEW LISTING!** 160,000
- Catalina 36 MkII, 2002..... **NEW LISTING!** 114,000
- Catalina 36 MkII, 2001 ..... 98,500

- Catalina 36 Tall Rig, 1985 .....51,000
- Catalina 350, 2005 ..... 133,000
- Catalina 34, 1989 ..... **NEW LISTING!** 49,300
- Catalina 30, 1984 ..... **NEW LISTING!** 29,000
- Catalina 250, 1997 ..... **NEW LISTING!** 15,000

**Preowned Sailing Yachts at Our Docks**

- Moody 42 DS, 2001 ..... 249,000
- C&C 41, 1984 .....59,000
- Beneteau Oceanis 373, 2005 .....137,000
- C&C 38, 1979 .....45,000
- Hunter 310, 2007 .....79,900
- Corsair 24-750, 2006 **TRAILERABLE TRIMARAN!** 39,950
- New Ranger Tugs (base price)**
- Ranger 31 Tug, 2012 ..... **NEW MODEL!** 279,937

- Ranger 29 Tug, 2011 ..... **DISCOUNTS!** \$229,937
- Ranger 27 Tug, 2011 ..... **DISCOUNTS!** 159,937
- Ranger 21-EC Tug, 2011 ..... **NEW LISTING!** 49,937

**New Cutwater Boats in Stock**

- Cutwater 28, 2012..... **AT OUR NEWPORT OFFICE**
- Cutwater 26, 2012..... **AT OUR NEWPORT OFFICE**

**Preowned Ranger Tugs at Our Docks**

- Ranger 25 Tug, 2009 ..... **LET'S MAKE A DEAL!** \$125,900
- Ranger 25 Tug, 2008 ..... 110,000

**Preowned Power Yachts**

- Tiara 4300 Sovran, 2008 ..... \$475,000
- Regal 19 Bowrider, 2008..... **FAST & FUN** 21,950
- Carver 35 Super Sport, 2006 ..... **NEW LISTING!** 149,900
- Chaparral 310 Signature, 2006 ..... **NEW LISTING!** 89,900



FARALLONE

1070 Marina Village Pkwy  
Alameda, CA 94501  
(510) 523-6730

2801 West Coast Hwy  
Newport Beach, CA 92663  
(949) 610-7190

From San Diego, CA  
Call  
(619) 523-6730



**Winter Discounts Start NOW!**



**Bring your sails in for a complimentary evaluation**

At Hogin Sails we pride ourselves on working with our customers and their boats to design and manufacture the sails you need. With 35 years of sailing experience and more than 20 years in the sailmaking business, our sail designer will help you increase your boat speed and efficiency with a **new Hogin Sail**.

- New Racing & Cruising Sails
- Sail & Canvas Repair
- Roller Furling Conversions & Sun Covers
- New Custom Canvas

**(510) 523-4388**

1801-D Clement Avenue, Alameda, CA 94501  
At Alameda Marina

sales@hoginsails.com • www.hoginsails.com  
M-F 8:30-5 • Saturday by appointment only

## CALENDAR

great excuse to get your trailer sailer on the water, plus you'll sail under the London Bridge! Info, [www.sailhavasu.com](http://www.sailhavasu.com).

**Feb. 14** — Whether it's Krug Clos d'Ambonnay or Cook's, a bottle of bubbly, a box of truffles, and a dozen roses make the cabin of nearly any boat romantic for your Valentine.

**Feb. 15** — Islands of San Francisco Bay slide show by photographer James Martin at Corinthian YC, 7 p.m. Free. Call Modern Sailing at (415) 331-8250 or CYC at (415) 435-4771 for info.

**Feb. 18** — Singlehanded TransPac race seminar #5 is actually a cruise-in at Encinal YC. Tour race vets' boats and bring your own boat for show and tell. For more about the race or future seminars, go to [www.sfbaysss.org](http://www.sfbaysss.org).

**Feb. 25** — Celebrate the re-opening of the Bay Model after two years of construction at a gala! A new roof, 2,500 solar panels, structural work and a remodel make this Bay Area icon a must-see. Call for times. Info, (415) 332-3871.

**Feb. 25-26** — US Sailing Safety at Sea Seminar in Seattle. The two-day event meets requirements for offshore racers, and is perfect for all offshore sailors. Great timing for those sailing in the Singlehanded TransPac, Pacific Cup or Vic-Maui this summer. \$150 per person (\$250 for couples). Info, [seminars@thesailingfoundation.org](mailto:seminars@thesailingfoundation.org).

**Feb. 26** — Cal Sailing Club's free introductory sail at Berkeley Marina, 1-4 p.m. Info, [www.cal-sailing.org](http://www.cal-sailing.org).

**Feb. 28** — The North Sails/Easom Rigging Lecture Series continues with Eric Goetz from custom race boat builder Goetz Custom Boats at South Beach YC, 7-8:30 p.m. Free. Info, [www.southbeachyc.org](http://www.southbeachyc.org) or [bill@3dl.northsails.com](mailto:bill@3dl.northsails.com).

**Feb. 29** — Take the Leap Day off to go sailing!

**February, 1982** — It Was Thirty Years ago from the *Sightings* piece 'mile rock to look like candy cane':

The Coast Guard has decided that the Mile Rock light structure looks kind of bland in plain old white. They'll freshen it up this spring with some orange stripes.

We'd written the Coast Guard suggesting a pastoral scene. Perhaps a mural with cows, fruit trees, and a large vegetable garden would be appreciated by those coming in after many days at sea. Apparently the Coast Guard didn't think much of our idea.

**Mar. 3** — Sail a Small Boat Day. Free rides in a variety of different small sailboats at Richmond YC, 10 a.m.-3:30 p.m. Wear something warm and waterproof, and bring a PFD and change of clothes. Info, [www.richmondyc.org](http://www.richmondyc.org).

**Mar. 7** — In-the-water liferaft training class by Sal's Inflatables, 3:30-5 p.m. at Golden Gate YC, just before the Crew List Party. \$39. Reservations and info, (510) 522-1824.

**Mar. 7** — *Latitude 38's* Spring Crew List Party at Golden Gate YC, 6-9 p.m. It's early in the season so you can set up your crew sooner. \$5 for anyone 25 and under (with ID)! Only \$7 for the rest of us. See [www.latitude38.com](http://www.latitude38.com) for details.

**Mar. 8** — OYRA Season Kick-Off Party & Skippers Meeting at Berkeley YC, 7 p.m. Info, [www.yra.org](http://www.yra.org).

**Mar. 8-11** — San Francisco Ocean Film Festival celebrates the sea with films that increase awareness. \$12 per program or

LATITUDE / LADONNA



**Sailors in this summer's Singlehanded TransPac and Pacific Cup Races will sail past a candy-cane striped Mile Rock, thanks to a 30-year-old painting scheme.**



# Cityyachts

San Francisco's Yacht Broker



43 Years of Experience and Knowledge



42' Californian Motor Yacht, 1987  
\$125,000



33' Hans Christian 33T, 1984  
\$139,000



30' Carver 300 Aft Cabin, 1993  
\$59,000



Beneteau 370, 1991  
\$65,000



WestSail 32, 1977  
\$62,500



30' Cape Dory Cutter, 1982  
\$45,000



30' Albin Ballad, 1978  
\$25,000



Catalina 34, 1986  
\$39,000



36' Catalina MkII, 2002  
\$112,000



34' Legacy, 2003  
\$270,000



40' Cape Dory Explorer, 1993  
\$229,000



Sea Ray 390, 1985  
45-ft San Francisco Berth

10 Marina Blvd. • San Francisco, CA 94123 • sales@citysf.com • www.citysf.com

Toll Free: (877) 444-5091 • (415) 567-8880 • FAX (415) 567-6725

PLEASE VISIT OUR FUEL DOCK AT GASHOUSE COVE MARINA • OPEN 7 DAYS A WEEK • 9AM TO 5PM

# NEW J/111



Frank Sloopman's J/111 *Invisible Hand*  
Photo ©2011 Erik Simonson/www.h2shots.com

## HULL 44 IS HERE AND SAILING.

Get in on the fastest fleet  
coming to the Bay...  
the new J/111.



Dorian McKelvy and Jim Zaky's *Mad Men*

**SAIL**  
*California*

Alameda  
(510) 523-8500  
norman@sailcal.com  
steve@sailcal.com

www.sailcal.com

## CALENDAR

\$85 for a Film Program Pass. Info, [www.oceanfilmfest.org](http://www.oceanfilmfest.org).

**Mar. 10-Apr. 29** — The 3rd Annual Cruisers Rally to El Salvador starts in Mexico and meanders 'rally style' to Bahia del Sol in El Salvador. No entry fee and no whining! Info, [el-salvadorrally.blogspot.com](http://el-salvadorrally.blogspot.com).

**Apr. 12-15** — Strictly Sail Pacific at Jack London Square. Info, [www.strictlysailpacific.com](http://www.strictlysailpacific.com).

### Racing

**Feb. 4** — Double Up & Back. CPYC, [www.cpyc.com](http://www.cpyc.com).

**Feb. 4** — Perry Cup/Midwinter. MPYC, [www.mpyc.org](http://www.mpyc.org).

**Feb. 11-12** — Londerville Cup, HMBYC, [www.hmbyc.org](http://www.hmbyc.org).

**Feb. 25** — Island YC's Sadie Hawkins Race on the Estuary. Woman skipper, full crew. Chowder challenge afterward. Info, [iycracing@yahoo.com](mailto:iycracing@yahoo.com).

**Feb. 25** — Singlehanded #1. SeqYC, [www.sequoiayc.org](http://www.sequoiayc.org).

**Feb. 26** — Midwinter Champion of Champions. BYC, [www.berkeleyyc.org](http://www.berkeleyyc.org).

**Mar. 1-4** — Heineken Regatta, St. Maarten, West Indies. One of the world's great fun regattas — and some of the wildest parties. Info, [www.heineneregatta.com](http://www.heineneregatta.com).

**Mar. 3** — John Pitcher Memorial. CPYC, [www.cpyc.com](http://www.cpyc.com).

**Mar. 3-4** — California Dreamin'. StFYC, [www.stfyc.com](http://www.stfyc.com).

**Mar. 4** — Spring 1 & 2 PHRF. MPYC, [www.mpyc.org](http://www.mpyc.org).

**Mar. 9** — Guadalupe Island Race, a biennial single- or doublehanded race from Marina del Rey that uses Baja's Guadalupe Island as a turning mark. Serves as a qualifier for this summer's Singlehanded TransPac. Info, [www.pssala.com](http://www.pssala.com).

**Mar. 10** — Mercury Series #1. EYC, [www.encinal.org](http://www.encinal.org).

**Mar. 10** — Spring Dinghy. StFYC, [www.stfyc.com](http://www.stfyc.com).

**Mar. 10-11** — Big Daddy Regatta, a don't-miss Bay Area classic. RYC, (510) 237-2821 or [www.richmondyc.org](http://www.richmondyc.org).

**Mar. 17** — Get out of the Gate in the YRA-OYRA Lightship. StFYC, [www.yra.org](http://www.yra.org).

**Mar. 24** — If you missed your first chance to get out of the Gate, join Island YC's Doublehanded Lightship. Proceeds benefit United Cerebral Palsy. Info, [www.iyc.org](http://www.iyc.org).

**Mar. 31** — If the Lightship is peanuts to you, don't miss BAMA's Doublehanded Farallones. Info, [www.sfbama.org](http://www.sfbama.org).

**May 12** — If you prefer solitude, hit up the Singlehanded Farallones. SSS, [www.sfbaysss.org](http://www.sfbaysss.org).

**June 30** — If that's not enough for you, test your mettle in the Singlehanded TransPac, a 2,120-mile slide from the Bay to Hawaii. SSS, [www.singlehandedtranspac.com](http://www.singlehandedtranspac.com).

**July 16** — And if you'd like to share the adventure with friends, the Pacific Cup is for you. Info, [www.pacificcup.org](http://www.pacificcup.org).

### Midwinter Regattas

**BERKELEY YC** — Midwinters: 2/11-12. Chowder Races: Sundays through March except when it conflicts with above. Bobbi, (925) 939-9885 or [bobbi@jfcbat.com](mailto:bobbi@jfcbat.com).

**CAL SAILING CLUB** — Year-round Sunday morning dinghy races, intraclub only, typically in Laser Bahias and JY15s. Info, [racing\\_chair@cal-sailing.org](mailto:racing_chair@cal-sailing.org).

**CORINTHIAN YC** — Midwinters: 2/18-19. Michael, [racing@cyo.org](mailto:racing@cyo.org).

**ENCINAL YC** — Jack Frost Series: 2/25, 3/24. Info, [rearcommadore@encinal.org](mailto:rearcommadore@encinal.org).

**GOLDEN GATE YC** — Manuel Fagundes Seaweed Soup Series: 2/4, 3/3. Gary, (916) 363-4566 or [grsalvo@pacbell.net](mailto:grsalvo@pacbell.net)

**HALF MOON BAY YC** — Midwinters: 2/26, 3/18. Info, [www.hmbyc.org](http://www.hmbyc.org).

**ISLAND YC** — Estuary Midwinters: 2/12, 3/11. John, (510) 521-2980 or [iycracing@yahoo.com](mailto:iycracing@yahoo.com).

**LAKE MERRITT SC** — Robinson Memorial Midwinters: 2/11, 3/11. Vickie, (510) 236-8098.

**OAKLAND YC** — Sunday Brunch Series: 2/5, 2/19, 3/4.



# SAIL *California*

## YOUR PERFORMANCE YACHT SPECIALISTS

"The Fastest Sailboat Listings in the West!"

### ALAMEDA

1070 Marina Village Pkwy #108  
Alameda, CA 94501  
**(510) 523-8500**  
FAX (510) 522-0641

### SEATTLE

**SAIL NORTHWEST**  
7001 Seaview Ave. NW #140  
Seattle, WA 98117  
**(206) 286-1004**



**33' Back Cove, 2008**  
Cruise the Bay or Delta in style.  
Asking **\$279,000**



**Custom C&C 43, 1973 Evening Star**  
Beautifully appointed classic cruising yacht.  
Asking **\$299,000**



**50' Bakewell-White, 2002, Brisa**  
Cruise anywhere.  
Asking **\$615,000**



**53' J/160, 2001, Mandalay**  
Fully loaded.  
Asking **\$579,000**



**55' Tayana, Samadhi V**  
Many recent upgrades.  
Asking **\$249,000**



**Pacific Seacraft 40, 1999, DreamKeeper**  
Well equipped. Cruise anywhere.  
Asking **\$314,900**



**40' J/120 2000, Dayenu**  
2011 Big Boat Series winner.  
Asking **\$174,900**



**40' J/120, 2002, Alchera**  
Equipped for singlehanded/  
shorthanded offshore sailing.  
Asking **\$195,000**



**J/105s**  
We have 4 from  
**\$73,900**



**J/100, 2005, Brilliant**  
Cruise ready.  
Reduced **\$84,900**

55' Tayana, 1988, <i>Samadhi V</i> .....	\$249,000	40' J/120, '00, <i>Dayenu</i> .....	\$174,900	35' J/35C, '91*.....	\$89,000
53' J/160, '01, <i>Mandalay</i> .....	\$579,000	40' Summit, '08, <i>Soozal</i> .....	\$579,000	34' J/34, '85, <i>The Zoo</i> *.....	\$29,900
52' Santa Cruz, '99, <i>Renegade</i> .....	\$495,000	40' Olson, <i>Elka</i> .....	SOLD	34' MJM 34z, '05*.....	Reduced \$299,000
52' Santa Cruz, '98, <i>Hula</i> .....	SOLD	38' Sabre 386, '08, <i>Kuai</i> .....	SOLD	33' J/100, Hull #9, '05, <i>Brilliant</i> .....	\$84,900
52' TransPac with IRC mods, '03, <i>Braveheart</i> *.....	\$499,000	38' Sabre 38 MkI, '84.....	SOLD	33' Back Cove, '08.....	\$269,000
50' Bakewell-White, '02, <i>Brisa</i> .....	\$615,000	38' Pearson True North*.....	\$239,900	32' J/32, '02, <i>Tango</i> .....	SOLD
48' J/145, Hull #9, '03*.....	\$675,000	36' J/109, '03*.....	\$189,000	30' Mull custom, '74, <i>The Shadow</i> .....	\$40,000
48' 1D48, '96, <i>Chaya</i> .....	\$99,000	36' J/36, '82.....	\$59,000	30' Olson 911S, '89, <i>Halcyon</i> .....	SOLD
47' Valiant, '81, <i>Sunchase</i> .....	\$90,000	36' Islander 36, '72, <i>Absolute</i> .....	\$40,000	30' Olson 30, '79.....	SOLD
44' J/44, '90, <i>Phantom</i> .....	New Listing \$239,000	35' J/105, '02, Hull #581, <i>Business Time</i> .....	\$99,000	30' Peterson Half Ton*.....	Reduced \$19,900
44' Kernan, <i>Wasabi</i> .....	SOLD	35' J/105, '02, Hull #520, <i>Sea Room</i> .....	SOLD	29' MJM 29z, '07*.....	\$269,000
44' Wauquiez 43 Pilot Station*.....	\$299,000	35' J/105, '01, Hull #463, <i>Trickster</i> .....	SOLD	28' Alerion Express, '02*.....	Reduced \$59,500
43' J/130, '96*.....	\$184,000	35' J/105, '01, Hull #405, <i>Swoosh</i> .....	SOLD	28' Islander, '79*.....	\$16,900
43' Custom C&C, '73.....	\$299,000	35' J/105, '01, Hull #400, <i>Lulu</i> .....	\$105,000	26' J/80, '01, <i>Whiplash</i> .....	\$32,000
41' J/124, '05.....	\$239,000	35' J/105, '00, Hull #347, <i>Bald Eagle</i> .....	\$99,000	26' J/80, '01*.....	\$32,900
40' Pacific Seacraft, '99, <i>DreamKeeper</i> .....	\$314,900	35' J/105, '99, <i>Life Is Good</i> *.....	\$73,900	26' J/80, '04, <i>Heart Attack</i> .....	SOLD
40' J/120, '02, <i>Alchera</i> .....	\$195,000	35' J/105, '92, Hull #44, <i>Orion</i> .....	SOLD		

\* Denotes Seattle Boats

# SAIL *California*

www.sailcal.com

email: norman@sailcal.com, steve@sailcal.com

DEALERS FOR THESE FINE YACHTS:

*Santa Cruz*  
— YACHTS —





- NEW
- USED
- REFINANCE



# Boat Loans Made Easy®



Let our 30 years of experience go to work for you!

**Richard Tressler**  
866-377-3948 ext. 1047008

**www.essexcredit.com**

EQUAL CREDIT OPPORTUNITY LENDER

Loan Amounts from \$25,000  
Instant Loan Approvals\* • 90 Days to First Payment\*

\*Subject to Loan Program Guidelines and Credit Approval  
Reference Code = MAR931

## CALENDAR

John, (510) 366-1476 or [j\\_tuma@comcast.net](mailto:j_tuma@comcast.net)

**REGATTAPRO** — Midwinters: 2/11. Jeff, (415) 595-8364 or [jzarwell@regattapro.com](mailto:jzarwell@regattapro.com).

**RICHMOND YC** — Small Boat Midwinters: 2/5, 3/4. Opti Midwinters: 2/4, 3/3. Bob, [bbranstad@gmail.com](mailto:bbranstad@gmail.com).

**SANTA CRUZ YC** — Midwinters: 2/18, 3/17. Info, (831) 425-0690.

**SAUSALITO YC** — Sunday Midwinters: 2/5, 3/4. Dave Borton, (415) 302-7084 or [race@sausalitoyachtclub.org](mailto:race@sausalitoyachtclub.org).

**SEQUOIA YC** — Winter Series: 2/11, 3/17. Redwood Cup: 2/5, 3/11. Info, [www.sequoiayc.org](http://www.sequoiayc.org).

**SOUTH BEACH YC** — Island Fever Midwinters: 2/18, 3/17. Info, [www.southbeachyc.org](http://www.southbeachyc.org).

**TIBURON YC** — Midwinters: 2/11, 3/10. Rob, [race@tyc.org](mailto:race@tyc.org).

**VALLEJO YC** — Tiny Robbins Midwinters: 2/4. Info, [www.vyc.org](http://www.vyc.org) or (707) 643-1254.

Please send your calendar items by the 10th of the month to [calendar@latitude38.com](mailto:calendar@latitude38.com). If you're totally old-school, mail them to *Latitude 38* (Attn: Calendar), 15 Locust Avenue, Mill Valley, CA, 94941 or fax them to us at (415) 383-5816. But please, no phone-ins! Calendar listings are for marine-related events that either are free or don't cost much to attend. The Calendar is not meant to support commercial enterprises.

### February Weekend Tides

date/day	time/ht. LOW	time/ht. HIGH	time/ht. LOW	time/ht. HIGH
2/04Sat	0224/3.0	0823/6.0	1528/-0.1	2238/4.6
2/05Sun	0309/2.8	0910/6.2	1603/-0.3	2309/4.9
2/11Sat	0150/6.0	0742/1.0	1400/5.1	1941/0.9
2/12Sun	0230/6.1	0842/0.8	1506/4.5	2028/1.5
2/18Sat	0216/2.6	0824/6.3	1513/-0.4	2217/5.1
2/19Sun	0311/2.3	0919/6.3	1556/-0.4	2255/5.3
2/20Mon	0400/2.0	1009/6.2	1634/-0.3	2329/5.5
2/25Sat	0122/5.6	0727/1.1	1346/4.6	1921/1.5
2/26Sun	0152/5.5	0812/1.1	1437/4.2	1957/2.0

### February Weekend Currents

date/day	slack	max	slack	max
2/04Sat	1020 2355	0121/1.7E 1335/4.4E	0438 1742	0729/2.4F 2045/3.3F
2/05Sun	1104	0206/2.1E 1418/4.7E	0522 1819	0813/2.7F 2119/3.6F
2/11Sat	0959 2205	0023/3.6F 1252/3.2F	0333 1559	0626/4.1E 1846/3.6E
2/12Sun	1102 2254	0109/3.3F 1352/3.0F	0415 1707	0716/4.2E 1940/2.9E
2/18Sat	1010 2337	0124/2.2E 1330/4.7E	0428 1724	0724/2.9F 2034/3.9F
2/19Sun	1104	0214/2.6E 1419/4.8E	0521 1809	0817/3.2F 2116/4.0F
2/20Mon	0017 1153	0255/2.9E 1502/4.7E	0609 1850	0904/3.3F 2152/4.0F
2/25Sat	0945 2146	0003/2.9F 1232/2.7F	0309 1542	0558/3.6E 1817/2.9E
2/26Sun	1034 2223	0040/2.5F 1320/2.4F	0343 1635	0640/3.5E 1902/2.4E



# Yachtfinders/Windseakers

in the heart of  
San Diego's boating community

2330 Shelter Island Dr. # 207, San Diego, CA 92106

info@yachtfinders.biz

www.yachtfinders.biz

(619) 224-2349

Toll Free (866) 341-6189

#1 Selling Brokerage on  
the West Coast in 2010!  
Professionally staffed  
and open every day!



**62' DYNAMIQUE, '84** \$319,000  
\$70,000 price reduction! Her sleek lines and navy blue hull will be noticed no matter where you go. Transferable slip in Bay Area.



**49' CHOATE PETERSON, '85** \$107,000  
Easily handled by a couple, she has an extensive inventory list that will provide safety and comfort for any extended adventure.



**43' HUNTER LEGEND, '91** \$89,000  
This very hard-to-find Legend 43 features a cockpit with deep, wide seating and wide side decks - all in a classically clean look.



**42' BENETEAU IDYLLE, '85** \$62,900  
Two cabins, two heads, a large salon and nice galley complete with refrigeration - plus dinghy/outboard and fresh bottom paint.



**40' CUSTOM OLSON, '84** \$67,500  
With 2008 fully-battened Kevlar main, she packs a lot of power and she flies off the wind! Easily sailed by two competent sailors.



**40' VALIANT, '82** \$129,700  
Loaded with the gear needed for living on the hook while cruising. Come to San Diego to see what a real cruising boat looks like!



**40' C&C, '78** \$37,500  
She shows some wear, but carries the C&C pedigree. Upgraded rigging and electronics. Priced to move and a lot of boat for the money!



**38' ERICSON 38-200, '88** \$69,900  
Cham has been lovingly cared for. The sails were new in 2004 and show as new, and much of the running rigging is new. Very clean!



**36' CATALINA, '83** \$32,500  
Perfect entry-level coastal cruiser for someone wanting to experience the joys and freedom that sailing can provide. Eager seller!



**32' DREADNOUGHT KETCH, '72** \$29,000  
This neoclassic custom-built Dreadnought was built on a fiberglass hull by Bill Clark, a highly-regarded boat builder in San Diego.



**30' CHEOY LEE BERMUDA, '64** \$14,900  
Sail singlehanded or with a crew of ten. Feels like a sturdy offshore cruiser with easy-to-sail characteristics of a daysailer.



**29' ERICSON, '70** \$23,000  
An extremely clean coastal racer/cruiser, she's had a full rigging modernization with a focus on ease of handling and efficiency.

## SAIL A SMALL BOAT DAY

RICHMOND YACHT CLUB  
351 BRICKYARD COVE ROAD  
PT. RICHMOND, CA  
(510) 237-2821



FREE  
RIDES  
AND  
FREE  
HOTDOG  
LUNCH

M  
A  
R  
C  
H  
3  
R  
D  
SATURDAY 10 AM TO 3:30 PM



"The small-boat sailor is the real sailor."  
-- Jack London, 1912

This event is open to everyone - yes, EVERYONE! Expect to get wet, so bring warm, waterproof clothing. More info at [www.richmondyc.org](http://www.richmondyc.org).

Outboard Engine Owners:

## WE UNDERSTAND

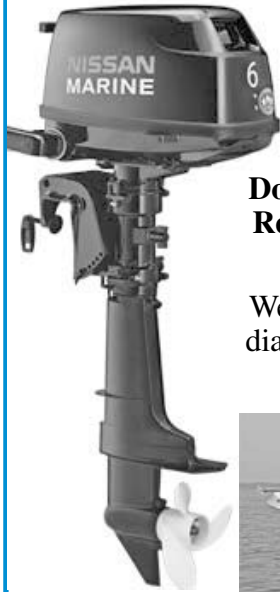

When an engine dies, there's no walking home – just costly repairs, lost vacation time, and lost revenues.

**Don't find yourself in this boat. Regular maintenance prevents expensive repairs.**

We are *your* experts for outboard diagnostics, repair, repower, sales and service.



- Factory-trained and certified techs
- Open six days a week
- New and used engines bought and sold
- One-year warranty on all work performed and used engine sales
- Three-year warranty on all new engines

**INFLATABLE, FIBERGLASS AND GELCOAT REPAIR**

## MARINE OUTBOARD

since 1990

**OUTBOARD SALES, SERVICE, REPAIR, PARTS**

**(415) 332-8020**

Nissan  
Tohatsu  
Johnson  
Evinrude



Honda  
Mariner  
Mercury  
Yamaha

**35 Libertyship Way • Sausalito, CA 94965**

**Conveniently located at Libertyship Marina**

*If we're not maintaining your outboard,  
you've missed the boat!*

## LETTERS

### ↑↓ **THE MAN IN THE WATER REEKED OF ALCOHOL**

At around 5:30 p.m. on New Year's Eve, I went down to a yacht harbor in Marin County to grab a forgotten item from my boat. When I got to the base of the ramp, I noticed a man trying to help an older, heavy-set man out of the water. Apparently the man in the water had unsuccessfully tried to make it down the ramp using a walker because of a recent hip injury.

I hurried down to help. Despite the cold saltwater dunking, the man reeked of alcohol. I could smell it before we even had him out of the water. Remembering the death of sailmaker Rui Luis from heart failure last June after he fell into the water, we had a passerby call 911 as soon as we got the man out of the water. The good Samaritan and I managed to get the man to his nearby boat so he could change into dry clothes and warm up.

Once the paramedics arrived, the other man and I felt the victim was in good hands, so we grabbed a long boat hook and used it to pull the man's walker out of the water. We also found a six-pack of beer that had apparently fallen out of the man's hands or walker and landed on the dock. I threw it in the trash.

In '08, one of my dock neighbors at Marina Village in Alameda fell off his boat in the middle of the night. I had walked by his boat after midnight — not long before he fell in and died — and saw him in the cockpit. He was totally inebriated. For what it's worth, he was a pilot for a major U.S. airline.

There's been a lot of talk about the need for ladders and other means of getting people out of the water around marinas. I think getting people into Alcoholics Anonymous or other rehab programs might do more than any number of ladders to prevent drowning deaths in marinas.

I also think marinas should start evicting tenants who frequently become inebriated. Maybe the threat of losing their boat slip will help people limit their consumption of alcohol.

Name Withheld By Request  
Sausalito

*Readers — We don't know how often alcohol is a factor when people fall into the water from a dock or boat and drown, but we suspect it's tragically frequent. So while we think ladders at marinas are a great idea, we agree with N.W.B.R. that they are not going to be the entire solution. We would also like to make it clear that alcohol consumption was not in any way a factor in Rui Luis's tragic death.*

*By the way, we edited this letter on January 17, the day after Jennifer Heather, 40, drowned at about 3:15 p.m. in a very narrow fairway of Southern California's Huntington Harbor that is chock-a-block with houses on both sides. It's unclear how she came to be in the water.*

### ↑↓ **THE CAPTAIN SHOULD ALWAYS HAVE THE FINAL SAY**

Latitude got it right in the January 18 edition of *Letronic* when you disagreed with the British Registrar's decision about who was responsible for the loss of life after a yacht delivery captain knowingly took off into forecasted storm conditions. The Registrar ruled that the yacht delivery company, based thousands of miles away in England, was responsible and that the captain, who knowingly sailed into those bad conditions, wasn't even 1% responsible.

Perhaps the Registrar's ruling was affected by the fact that there had been a similar incident with another Reliance Yacht Management delivery skipper in the middle of the Atlantic just two months before. Who knows, maybe the court decided to punish Reliance as an employer? But the reasoning of the court always offers a fascinating insight into cases that go





**SVENDSEN'S  
BOAT WORKS**  
1851 Clement Avenue, Alameda CA

**Boat Works** | 510.522.2886 or boatyard@svendsens.com  
**Chandlery** | 510-521-8454 or store@svendsens.com

**“From stem to stern, Svendsen’s does it all...  
This is a boater’s boat yard.”**

*– Customer Testimonial*



Svendsen’s Boat Works is a full-service boat yard, providing the highest quality repairs available to boaters in the Bay Area and beyond. Call to schedule: **510.522.2886**

Factory Authorized

**YANMAR**

- Engine/Parts Sales
- Full Service Engine Shop performing Repairs, Repowers, & Rebuilds

Svendsen’s carries a wide stock of Yanmar parts at competitive prices. We ship internationally. Special orders are welcome.



**SVENDSEN'S MARINE  
CHANDLERY**

1851 Clement Avenue, Alameda CA | 510.521.8454

## Marine 12-Volt Wind Generator

AIR Breeze produces maximum energy in lower winds and is so quiet that it blends into background sounds such as wind. It produces up to 38 kilowatt hours a month in an average 12 mph (5.4 m/s) wind. With an AIR wind turbine, you have energy wherever you go. AIR turbines are lightweight, easy to set up, and produce clean DC power to directly charge batteries to run your lights and charge satellite phones, GPS devices, any small appliance - keeping you connected, charged, and ready to enjoy your adventures.

**Air-1-ARBM-10-12 Airbreeze Marine 12 Volt - \$1,195**



# The Fix is In

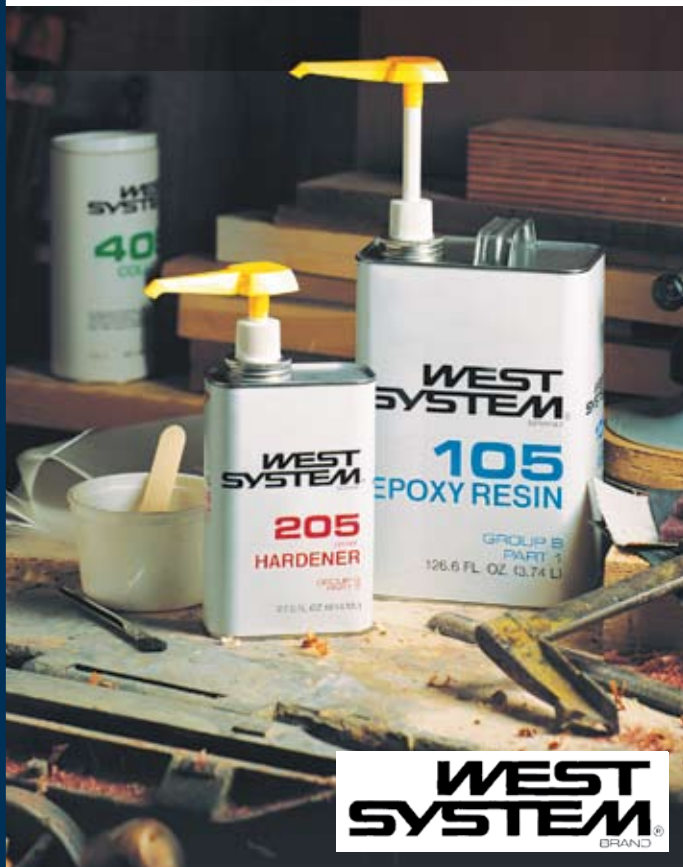

**WEST  
SYSTEM**  
BRAND®

## West System® Brand Epoxy

For the almost limitless care and repair needs aboard a boat, the fix is in the can of WEST SYSTEM® Brand epoxy. Gluing, filling, coating, fairing—there's not much you can't do with this remarkable epoxy resin and the right filler(s). We've got the complete WEST SYSTEM Brand product line at West Marine. So the next time you need a fix, come on in!

 **West Marine®**

Contact us for all of your Rigging Needs!  
**888-447-RIGG**

We have 17 stores in Northern California,  
including our Alameda Sailing Superstore!  
Visit [westmarine.com](http://westmarine.com) to find the store nearest you.

## LETTERS

against common maritime law.

As both a maritime lawyer and a delivery skipper, I believe the captain should always have the final say on when to leave port. That's why I have made that stipulation an important part of my standard delivery contract. Not only do I retain the right to make the decision, but I have built in the amount I am to be paid for laydays because of either having to fix an unseaworthy item on the boat or because I have to wait for a weather system to pass.

It makes me sad to read about lives lost because a captain makes a bad choice not only for himself/herself, but for the other crewmembers, when he/she had the alternative to walk away. Someone would have to be desperate for a job to risk their life and that of others when the chips were stacked against them.

Linda Newland  
Port Townsend, WA

*Readers — Linda Newland has done a number of singlehanded and crewed crossings to Hawaii, and to our knowledge is one of only three Northern Californians to have singlehanded to Japan.*

*If you're interested in what we said, flip over to page 68 in Sightings for the complete text.*

### ↑↓ DIANA CHALLENGED THE SKIPPER'S DECISION

I think there is evidence that delivery skipper John Anstess wasn't considering his crew's safety when he set sail on the delivery of *Cat Shot* in December of '06. I clearly recall Diana Jessie — the well-respected Northern California circumnavigator who recently passed away — telling me and some dockmates about a conversation she had with Anstess before he headed north from San Francisco. He had come into Waypoint Marine to purchase a chart, although not a detailed one, of Northern California waters. During a conversation with Diana, he told her of his plans to head north. She challenged his decision knowing, as did he, that there was a big storm on the horizon. From what I understand, Anstess' two crew were not experienced sailors.

I wasn't surprised when I learned that the cat had flipped and all three aboard had died.

I can imagine a skipper going against the weather — and knowledgeable advice — only once. If he made it through alive with nothing worse than the crap being scared out of him, he could consider himself lucky.

You can call me a 'fair weather sailor', but I say shame on Anstess.

As for my dear friend Diana Jessie, may she rest in peace.

Karen Crowe  
Sogno d'Oro, Pearson 422  
Alameda

### ↑↓ "THEY SHOULD SHARE THE BLAME"

I don't completely agree with your view. Yes, I see your point about delivery captains' having the responsibility to themselves and their crew to decide if they will sail into bad weather. However, as you can see from the example you used, Reliance Yacht Management has a pattern of pressuring delivery captains into unsafe conditions. Maybe the responsibilities should be shared by Reliance and the delivery captain.

Ray Chang  
Blossom, Pearson Triton  
Alameda





# MODERN SAILING SCHOOL & CLUB

Sausalito, CA

www.ModernSailing.com

(415) 331-8250



Membership initiation is \$200 off for the month of February. (This makes the pricing \$175 for students and \$375 for non-students.)

## Partial list of our fleet:

Beneteau 423	Beneteau 311
Caliber 40	C&C 32
Beneteau 393	Pearson 32
Beneteau 38	Ericson 32
Catalina 36	Catalina 30
Beneteau 35	Catalina 30
Beneteau 33	Ericson 30

## Get your Coast Guard Captain's License

Feb. 13-17, 20-25  
Mon-Fri, 9am-5:30pm  
Next Class: August 6-18



**OUPV LICENSE**  
\$995  
**100 TON LICENSE**  
\$1195

**GUARANTEE:** Our U.S. Coast Guard Approved course will prepare you for all elements of the exam, guide you through the application process, and conclude with on-site testing. Space is limited. Sign up today!

## Upcoming Events

- Feb. 11 – Club Sail / Chili Chow Down, MSC
- Feb. 15 – Islands of the Bay Slide Show Presentation, Corinthian YC
- Feb. 18 – Dinner Sail @ Horizons
- Feb. 19 – Angel Island Hike, Club Sail
- Feb. 20 – Member Appreciation Day Charter Specials
- Feb. 25 – Adventure Sailing Party – Social Mixer
- Mar. 3 - Crew Overboard Clinic (9-4)
- Mar. 19-26 - Heavy Weather Offshore Course: SF to Monterey and back



**Expertly Maintained:**  
Our fleet is second to none in quality and cleanliness.



**Catamaran:**  
This 38 foot Catamaran sails beautifully.



## Adventure Sailing with John Connolly



Holly Williams

Volcanic crater on the back side of Bora-Bora, one of our destinations

## South Pacific 2012

### LEG 1: June 7 - 17

*Raiatea, Tahaa, Bora-Bora, Tiekahau, Rangiroa.*

### LEG 2: June 20 - 30

*Rangiroa back to Raiatea. This leg makes landfall on Bora-Bora and visits Tiekahau, Tahaa and Raiatea.*

\$2450 / berth  
\$4700 / cabin

**ASA 108 Ocean Passagemaking**

## Start Sailing Lessons Today!

- Basic Keelboat Course (ASA 101) \$650
- Basic Coastal Cruising (ASA 103) \$750
- BKB / BCC Combination weekend combo - \$1300  
M-Fri (5 day) - \$1095

*Both weekend and weekday courses available!*



ASA Outstanding School 2009 & 2010



# Cleaner Bottoms Start Here



## Quality Antifouling Paints for Every Boat

No matter what kind of boat you have, or where you use it, there's a West Marine Antifouling Paint that's ideal for your needs. From our popular BottomShield modified epoxy, to the latest in ablative technology paints, including our CPP Plus and PCA Gold—we've got a West Marine paint that'll keep your boat's bottom clean! And since it's from West Marine, you know you're getting a great value!

# West Marine®

Contact us for all of your Rigging Needs!  
**888-447-RIGG**

We have 17 stores in Northern California, including our Alameda Sailing Superstore!

Visit [westmarine.com](http://westmarine.com) to find the store nearest you.

## LETTERS

Ray — We respect your differing opinion. Nonetheless, we believe that only one person can make the final decisions on a boat, and that person has to be the captain.

By the way, we've received a credible report that the delivery skipper who died crossing the North Atlantic for Reliance in the winter made the decision to sail that far north. We hope to get permission to release all the details on that tragedy for the next issue, as they are quite illuminating.

### ↑↓ DOESN'T RELIEVE THE SKIPPER OF HIS DUTIES

Hear, hear to *Latitude's* comments on a skipper's responsibilities on deliveries — which are no different than at any other time: responsibility to life, limb and vessel — which, by the way, belongs to an owner, not a delivery company — in that order.

Shame indeed on Reliance Yacht Management, too, and a fine be on their heads if their pressure tactics were real and significant. However, this still doesn't relieve the skipper of his obligations. May that message of responsibility be deeply internalized by all skippers.

Tim Dick  
Sausalito / Honolulu

### ↑↓ 'JUST FOLLOWING ORDERS'?

*Latitude's* recommended "F--k you!" to a yacht delivery company that pressures a delivery captain to set sail in terrible weather is the only legitimate response. Whether endangering your own life or that of others, there is absolutely no defense to 'just following orders'. The moment one compromises, the fault becomes shared, as should the unfortunate penalty.

John McNeill  
Yankee  
San Francisco

### ↑↓ TRANSPARENCY IN LEGAL PROCEEDINGS

My balanced view is that it would first be the captain's responsibility, but if it can be shown that the company issued unsafe directions with the threat of financial penalty, then the company is at least 50% responsible for what happened. And perhaps 100% if the captain and crew die as a result.

Tom Dalglish  
Waverly, Islander Freeport 41  
Seattle, WA

Tom — It would have been nice if the Registrar had released the evidence of "pressure." After all, what's wrong with a little transparency in legal proceedings?

Given that international law states that a captain is in "ultimate command" of the vessel, and is "responsible for its safe and efficient operation, including navigation," it's our opinion that the delivery company would have had to apply an inordinate amount of pressure — as we mentioned, a knife to the throat of the captain's mother — for the captain not to be responsible. If it was merely a case of the company offering the captain a 50% bonus if he took off into the storm, we think the captain bears full responsibility.

### ↑↓ STRANGE STUFF AT SEA AT NIGHT

In the December 28 *Lectronic*, you mentioned that Brian Thompson on the Jules Verne record-setting 131-ft trimaran *Banque Populaire* saw a light in the Southern Ocean that none of the very experienced crew could explain. You then asked if readers had seen similar mysteries when sailing at night. I have.

During an evening sail from Marina del Rey to Catalina Island on my Cal 25, I saw some strange and eerie figures.



# THE FINEST SAILS BEGIN WITH THE BEST SAILCLOTH

Call now  
and  
**SAVE 20%**  
with our  
winter  
discounts

Our patented woven Vectran® sailcloth performs like the laminates with the durability of Dacron®, especially in roller furling applications. In fact, Vectran® is lighter, lower stretch, and retains its shape over a longer life than any sailcloth we've ever offered to cruising sailors. That's because Hood Vectran® is woven, not laminated to Mylar® film. And you can be sure that each sail we roll out is built by hand, with the same care and craftsmanship that has been the Hood hallmark for 50 years. To discuss your sailcloth needs – whether our state-of-the-art Vectran® or our soft, tight-weave Dacron® – give us a call today.

**HOOD** Sails & Service

**HOOD** New Sails

**HOOD** Sail Repairs

**HOOD** Furling Conversions

**HOOD** Pickup & Delivery



SAILMAKERS

## Chesapeake

Jim Fair's Outbound 46  
with Hood Vectron  
Full Batten Mainsail,  
140% Genoa, and  
Solent Jib

PHOTO COURTESY  
SWIFTSURE YACHTS  
[www.OutboundYachts.com](http://www.OutboundYachts.com)



HOOD SAILMAKERS 465 Coloma Street, Sausalito, CA 94965

Call Robin Sodaro (800) 883-7245 (415) 332-4104 Fax (415) 332-0943 [hoodsails@aol.com](mailto:hoodsails@aol.com)

Visit our website for Special Online Discount Pricing... [www.hoodsailmakers.com](http://www.hoodsailmakers.com)

# Forget about it!

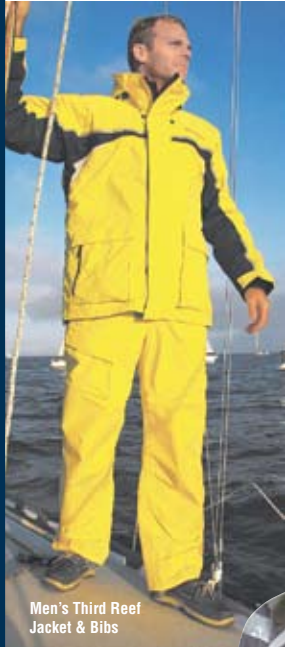

Men's Third Reef Jacket & Bibs



Women's Third Reef Jacket & Bibs



Men's Navigator Jacket & Bibs

**Better gear means better sailing for you!**

From the cut to the latest technical fabrics and countless construction details, we've thought through every aspect of our waterproof gear to ensure that you won't have to think about it. Because matching your skills against the wind, waves and current is challenging enough!

Our Third Reef and Navigator gear are 100% waterproof, yet they breathe to ensure that you don't become uncomfortably clammy. The fabrics are lightweight and supple, yet they're incredibly tough, and reinforced in critical areas so they won't tear.

Learn more about our Third Reef and Navigator at [westmarine.com](http://westmarine.com), or visit the West Marine store in your area.

 **West Marine®**

**Visit our stores! For the location nearest you, go to [westmarine.com](http://westmarine.com)**

## LETTERS

The first was a grotesque face looking up at me from below the surface of the water. Its tongue was sticking out at me. Next I saw faces looking up at me from both sides of my boat,



DAN BURBANK / ISS

and for several minutes at a time. They were Day-Glo blue in color, but also translucent. Then some of these people poked their heads out of the water and smiled at me.

If that wasn't enough, some of the people came out of the water and started running back and forth on the surface of the water in my boat's path. Some of these glowing people were close enough to touch, while others ran off and disappeared into the dark horizon. Their images were very clear, and I could make out quite a bit of detail.

**The 'Banque Populaire V' crew undoubtedly witnessed Comet Lovejoy — a.k.a., The Christmas Comet.**

The figures didn't come across as threatening, but playful instead. I didn't have the urge to jump out of the boat and run after them, but I was happy enough to watch them frolicking around in front of my boat. This 'show' seemed to go on for quite a while, until something snapped me out of it.

For the record, I hadn't been taking any medications or drinking any alcohol.

Don Feld  
Healing Lightly, Cal 25  
Marina del Rey

*Readers — It is widely believed that what Thompson and his fellow crewmembers saw on Christmas night was the newly discovered Comet Lovejoy.*

### ↑↓ **HAVING GONE TO COLLEGE IN THE '60S . . .**

In the spring of '92, we did a practice run from San Francisco to Monterey aboard the Freedom 44 cat ketch *Ivory Goose* in preparation for the Pacific Cup. I was alone in the cockpit for the midnight to 4 a.m. watch. I was well-rested and full of coffee, so I wasn't worried about becoming drowsy. We just happened to be beta-testing an early Trimble Navigation GPS system that was hooked into the steering, so I didn't have to hand steer or worry about our heading.

Around 3:30 a.m. I was jolted upright by the sight of a racing boat on port tack coming on strong from starboard to port across our bow. Although the boat was showing no lights, I could tell that she was really heeling over, and there were three members of the crew on the rail with their backs to me. One of them had blond hair. Their helmsman was looking away from us, so I started screaming and tried to muscle the wheel to turn our boat down. But as the Trimble unit was in control, I couldn't turn the boat. Just as we were about to T-bone the other boat, she was no longer there. Nothing.

It was the most believable hallucination I've ever experienced. And I went to college in the '60s.

Fred Walter  
Healdsburg

### ↑↓ **THE UNEXPLAINABLE**

It was about 10 p.m. on a late August night in '08, and we were sailing about 12 miles offshore about 30 miles south of Pt. Sur. It was very windy, with gusts to 40 knots. About this time our entire crew of four observed a shining area in the



# THE BOAT YARD AT GRAND MARINA

"Where Service Has Meaning"

**FREE  
HULL WAX  
WITH  
BOTTOM  
JOB**

**Interlux.**  
yachtpaint.com

**AWLGRIP**  
REG. U.S. PAT. & TM. OFF. © 2008

**60-TON  
TRAVELIFT**

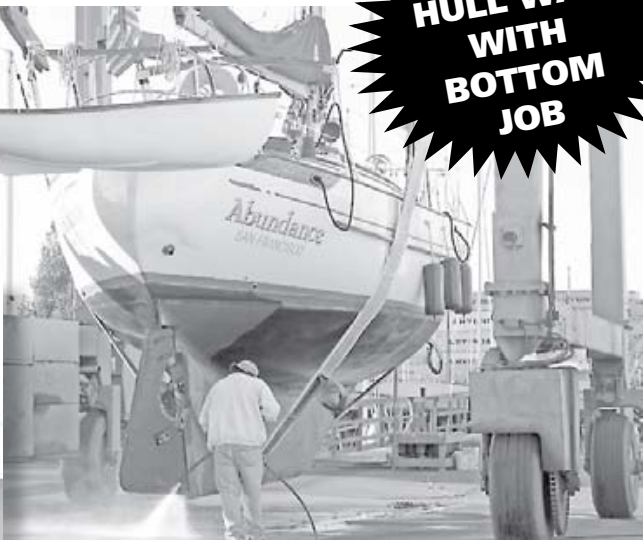

FEATURING  
TRINIDAD  
ANTI-FOULING PAINT BY  
**PETTIT**  
  
Go clean into the future.  
RATED "SUPERIOR" by  
Practical Sailor

*The only yard to brush on your bottom paint!*

Dealers for:

**MAX-PROP**  
AUTOMATIC FEATHERING PROPELLERS

**GORI**  
marine

**Webasto**

PACKLESS SEALING SYSTEM  
**SHAFT SEAL**

**Lectra/San**

**SIDE-POWER**  
Thruster systems

**facnor**  
FURLING SYSTEMS INC.

**AQUAMARINE**  
FINE REVERSE OSMOSIS EQUIPMENT

## IT'S SIMPLE!

Call The Boat Yard at Grand Marina for the Lowest Bottom Prices!

~ COMPARE US WITH THE COMPETITION ~

- Prop and Shaft Work
- Mast & Rigging Repair
- Fiberglass & Blister Repair
- Gelcoat Repair
- Gas & Diesel Engine Service
- LPU Hull & Topside
- Electrical Repair & Installation

**CALL FOR A RESERVATION**

(510) 521-6100 • Fax (510) 521-3684

Located at Grand Marina • 2021 Alaska Packer Place, Alameda

[www.boatyardgm.com](http://www.boatyardgm.com)

# WHALE POINT MARINE & HARDWARE CO.

**A FAMILY OWNED & OPERATED BUSINESS FOR THREE GENERATIONS**  
**ACE Hardware**  
 MARINE PARTS & ACCESSORIES, PLUS A COMPLETE HARDWARE STORE

Go to [WhalePointMarine.com](http://WhalePointMarine.com) for additional discounts!

**TIDE LOG 2012 ARE HERE!**

COME AND GET ONE

NOW \$13<sup>99</sup>



**2012 CALENDARS**



Many styles available: Woodenboat, Sail, Art, Mariners Book of Days, Light-houses, 7 Seas calendar, Cruising, World of Boating, Bay Area Tide Calendar...  
**30% OFF** in stock only

**SEADOG 5' Folding Ladder**

- Ladder becomes stiffer as weight is applied
- Supports 300lb
- Corrosion resistant plastic
- Bottom rung sinks below surface



List \$44.99 • NOW \$29<sup>99</sup>

**GOLDBRAID Nylon Dock Lines**

With approx 12" loop in 1 end.



3/8" x 15'....\$10<sup>99</sup> 1/2" x 20'....\$16<sup>99</sup>  
 3/8" x 20'....\$12<sup>99</sup> 5/8" x 20'....\$24<sup>99</sup>  
 1/2" x 15'....\$16<sup>99</sup> 5/8" x 25'....\$29<sup>99</sup>

**JOHNSON Toilet**

NOW \$149<sup>99</sup>



**FORCE 10 3 Burner Propane Stove**

**FORCE 10**

Model 63351

3-burner

NOW \$1239<sup>00</sup>

Model 63251: 2-burners

NOW \$1199<sup>00</sup>



**STEARNS Cold Weather Gloves**

NOW \$19<sup>95</sup>



**PORTABLE HEATER**

Indoor safe propane heater.



Mr Heater

4,000-9,000 BTU: NOW \$99<sup>99</sup>

205 Cutting Blvd, Corner of 2nd, Richmond  
 510-233-1988 • FAX 233-1989

Mon-Sat: 8:30am - 5pm • Sun: 10am - 4pm • [whalepoint@acehardware.com](mailto:whalepoint@acehardware.com)

Go to [WhalePointMarine.com](http://WhalePointMarine.com) for additional discounts!

## LETTERS

cloud cover as if there were a full moon. But there wasn't a full moon. The light was about 75 degrees above the horizon, and constant enough to steer by. It stayed there all night, so it wasn't the moon. We never could figure it out.

Lawrence Riley  
 Arowana, Diva 39  
 Richmond YC

### ↑↓ SPARKS LIKE FROM A ROMAN CANDLE

We left Marina del Rey bound for San Diego at midnight on a Friday in early November of '93. There was no wind. At 2 a.m., having rounded Palos Verdes Point, I saw this very bright white light from what I assumed was a boat. It seemed to come from the surface of the water about a mile just off our port bow. It was moving swiftly across our bow from left to right, appeared to be on fire, and was shooting out sparks like a roman candle. For the next two minutes, it continued its course toward the western horizon at what I estimated to be something in excess of 100 knots. I could not see any running lights or an outline of the boat. I can think of no rational explanation for what I saw.

Devan Mullin  
 Points Beyond, Shannon 38 ketch  
 Newport Beach / Key West, FL

### ↑↓ WIND IN THE RIGGING

I didn't see it, but the strangest thing I ever heard at night was an Italian men's chorus serenading me. It was a lovely treat to help the time pass, and I never did figure out the source. Wind in the rigging?

Bill Fleetwood  
 Blue Banana, Gulfstar 50  
 Monterey / Cartagena, Spain

### ↑↓ STRANGE STUFF NOT SEEN AT SEA

This is not about the strangest thing I've seen on the ocean, but rather the strangest thing I *didn't* see. We were on our way from Los Frailes to Cabo with a dead diesel. About 20 miles from Cabo, in a mill pond-like sea, we noticed that even though we had six knots of apparent wind from astern, and the boat was maintaining steerage, the GPS indicated that our boat speed over the bottom was 0.0 knots. Wow, we figured, it must be a strong current against us. But something just didn't feel right, so we turned the boat around 180 degrees. Now we had six knots of wind coming over the bow, there was a substantial current coming from astern, and our speed over the bottom was still 0.0 knots!

Perplexed, we got out the back-up GPS. It produced the same 0.0 reading. We were getting a little weirded out, so we turned the boat 90 degrees in one direction, then the other. We still had six knots apparent from the east, significant current from the west, but no movement over the bottom. Our chart indicated that we were in 2,000 feet of water, so we certainly weren't aground. We considered putting someone over the side to see if perhaps we were hung up on a fishing net or a long line, but the speed of the current past the hull made this a risk we didn't want to take on the open ocean.

By then we had some light from the coming dawn, so we launched the dinghy, and keeping it secured to the boat, looked to see if there was anything unusual in the very clear water. *Nada*. And mind you, we could easily see the silhouette of our keel and rudder. Our next trick was to pass a line completely beneath the boat. Taking a 40-ft length of light line, weighted in the middle with a shaft zinc, we led it under the bow and passed the ends down each side under the entire



# The bottom line...



- Lift capacity 35 tons
- Sprayed Racing Bottoms
- Full Painting Service
- Fiberglass & Gelcoat Repairs
- Rigging Repairs & Installation
- Electrical Repairs & Installation
- Engine Service & Repowering
- Propeller Installation & Tuning
- Wood Hull Repairs & Caulking
- Teak & Non-Skid Deck Repairs

The spring racing season is almost here – now is the time to get that bottom in shape! Ask us how a Berkeley Marine racing bottom can boost the performance of your boat!

Call us to schedule your haulout today!



## Berkeley Marine Center

*The yard that works for you!*

In Berkeley Marina • 510-843-8195 • [www.berkeleymarine.com](http://www.berkeleymarine.com)

Chandlery & Fuel Dock Open 7 Days Mon – Fri 8 to 5 • Sat & Sun 9 to 5

# CRUISE CONTROL

Install Harken Radial electric winches and keep your cool—push-button control puts shorthanded sailing or a relaxed evening cruise right at your fingertips.



## Radial®

New Radial winches are designed for safety, smooth easing, and simple maintenance. Buy electric or easily upgrade a manual version with power.

Also available in hydraulic.

## UniPower™

Even owners of smaller boats can enjoy effortless winching; the Radial Unipower's compact motor conserves headroom in the smallest of cabins.

## Rewind™

The Radial Rewind does all the work for a totally hands-off affair. Install the controls anywhere to sheet in AND out with the touch of a button.

**HARKEN®**  
INNOVATIVE SAILING SOLUTIONS

Visit [www.harken.com/electric-winches](http://www.harken.com/electric-winches) and find out which powered winch is right for you.

## LETTERS

length of the boat. Again *nada!*

So there we sat, trying to assure ourselves we were not hallucinating. Hell, we had run out of drugs months before and we don't drink at sea, so what was going on? We will never know, because as suddenly as whatever was happening, it went away. Our boat began sailing, albeit slowly, in the now very light breeze toward Cabo San Lucas. (Close with sound of theme from "The Twilight Zone.")

I swear it's all true.

Jimmie Zinn  
Dry Martini, Morgan 38  
Richmond YC

*Readers — We received a number of 'strange things seen at night at sea', so we're saving a few for next month.*

### ↑↓ DEEP PREJUDICE AGAINST YOUNG PEOPLE

I love *Latitude*, but I'm dismayed at the lack of even



**Dekker, 16, completed her solo circumnavigation in St. Martin on January 21.**

the slightest mention about 16-year-old Laura Dekker's incredible effort to become the youngest person to complete a circumnavigation. I realize you have a deep prejudice against young people attempting/accomplishing such feats, but her maturity and skill at managing to get a 38-ft ketch alone around

the world is noteworthy. The fact that you intentionally ignore this girl and her accomplishment does not go without notice.

Rich Johnson  
Washington

*Rich — We haven't ignored Ms. Dekker's attempt, as we've written about it a number of times. But you're correct, we intentionally haven't gone out of our way to celebrate it.*

### ↑↓ HOPE THE SHRINK CAN HELP WITH OUR DISORDER

I'm writing with regard to the comment that appeared in the January 11 *Lectronic* regarding 16-year-old solo circumnavigator Laura Dekker: "All we know is that the perception of the bar for singlehanded around the world will be lowered as soon as Dekker reaches St. Martin because it will be "so easy that even a 16-year-old girl can do it."

The person who made that comment ought to have his head examined, as it has to be one of the most stupid opinions I've ever run across in your rag. Why not acknowledge that Laura is a superb sailor? Are you jealous? Misogynist? Have an anti-youth disorder? You know damn well the seamanship and courage it takes to brave the ocean alone, regardless of your age or gender. Why disgrace your otherwise wonderful magazine with such belittling twaddle?

Michael Childs  
Sparrow, 30-ft Seychelles gaff ketch  
Wilmington

*Michael — Please read the 'Lectronic item more carefully. Start with the second line of the second paragraph where we wrote: "... we admire Dekker's resolve, courage and skill." We don't believe that expresses jealousy or misogyny.*

*And if you read the last line of the piece again, you'll notice*





# YACHT BROKERAGE - SALES & SERVICE [WWW.JK3YACHTS.COM](http://WWW.JK3YACHTS.COM)

**SOLD, SOLD, SOLD-WE ARE LOOKING FOR QUALITY LISTING, CALL US TO SELL YOUR BOAT!**



**65' World Cruiser**  
2006 65' J/65  
MAITRI \$2,100,000



2006 49' Jeanneau Sun Ody DS  
ELIXER \$449,000



2007 44' Mochi Dolphin 44  
CATTIVO \$749,000



**Twin Jet Drives**  
2006 43' Oyster 43 LD  
VARUNA \$650,000



2005 43' J/133  
PICANTE \$350,000



**PacCup Ready!**  
TransPac 2011  
1994 42' J/130  
Bebe \$CALL



1999 41' J/125  
AUNT JESSIE \$269,000



**New Sails/Bottom**  
2007 40' J/124  
FORGIVENESS \$250,000



**IRC Champion**  
2008 40' King / Summit 40  
Soozal **Call For Current Price**



2002 36' Sydney 36 Sports  
FINS \$175,000



1998 38' Beneteau 36s7  
HONCHO \$89,000

- SAIL.....**
- 2007 70' CNB 70 \$3.2M
  - 2000 53' J/160 **SOLD**
  - 2006 52' TP52 **SOLD**
  - 96/09 41' J/125 **SOLD**
  - 1994 40' J/120 \$105K
  - 2002 40' C&C 121se \$230K
  - 2007 40' Delphia 40 \$172K
  - 2000 38' Catalina 380 \$122K
  - 2007 33' Cross Current \$199K
  - 2010 31' J/95 **SOLD**
  - 2003 28' Corsair 28R **SOLD**



2005 Beneteau 36.7  
WILSON \$125,000



**Race / Cruise**  
2004 35' J/109 Blue Crush \$187,500  
2004 35' J/109 Duster II \$189,900  
2007 35' J/109 Joyride \$191,000



2001 35' J/105 Javelin \$103,500  
2000 J/105 Lightwave \$92,000  
1992 35' J/105 Pholly \$91,500

- POWER.....**
- 2008 44' Renzo Coupe \$549K
  - 2005 38' True North 38 \$340K
  - 1996 31' Albin TE **SOLD**
  - 2009 30' RAIDER RIB \$59K
  - 2006 29' Back Cove 29 **SOLD**

## DEALERS FOR THE FOLLOWING BRANDS: 619.224.6200 Main Office



**New Model on Order**  
SABRE 38 Salon Express  
with IPS Drives



**In Stock - San Diego**  
All New BACK COVE 30



**Arrives San Diego Jan 16**  
Hanse New 385



**In San Diego "NOW"**  
SABRE 426 Performance Cruiser

**SAN DIEGO, CA**  
Jeff Brown  
Jeff@jk3yachts.com  
619.709.0697

**SAN DIEGO, CA**  
Kenyon Martin  
Kenyon@jk3yachts.com  
858.775.5937

**NEWPORT BEACH, CA**  
John Zagorski  
John@jk3yachts.com  
310.947.2092

**HOUSTON, TX**  
Tom Binig  
Tom@jk3yachts.com  
713.725.2397

**ALAMEDA, CA**  
Chris Corlett  
Chris@jk3yachts.com  
510.914.1073

# SCHOONMAKER POINT MARINA

• IN SAUSALITO •



**160-Berth Marina in one of the most beautiful spots on the Bay**



- Visitor berths • Guest moorage up to 220 ft.
- 35-ft to 75-ft slips • Pumpouts • Marine services
- Dry Storage Available • Three-ton hoist
- Restaurant • Beach • Rowing • Kayaking

## Sausalito's Finest Marina

85 LIBERTY SHIP WAY, #205  
SAUSALITO, CA 94965

**415•331•5550**  
**FAX 415•331•8523**

[www.schoonmakermarina.com](http://www.schoonmakermarina.com)

## LETTERS

that we didn't write that doing a singlehanded solo circumnavigation was so easy that even a 16-year-old girl could do it — but rather that it would be the perception many people would take away. You might call it the 'Jordan Romero Effect', after the Big Bear resident who, 18 months ago, scaled Mt. Everest at the tender age of 13.

In a curious way, both Romero and Dekker have diminished their respective accomplishments, because they proved that a 13-year-old boy could indeed climb Everest, and that a 16-year-old girl could indeed solo circumnavigate. And on their first attempts! This is going to be puzzling to lay people who don't understand how critical favorable weather is to success in both climbing and sailing. Who would argue that far better climbers than young Romero have died trying to scale Everest, and that far better sailors than Dekker have died trying to sail around the world alone? In most cases it was a matter of the deceased's having been confronted by much worse weather.

### ↑↓ LAURA CONSIDERS GUPPY TO BE HER HOME

Initially I was in agreement with *Latitude's* strong position against age-based sailing records. After all, one only needs to think of the problems endured later in life by child movie stars and Olympic gymnasts pushed by their parents. But I changed my mind when I serendipitously met Laura Dekker while in Port Elizabeth, South Africa. I found her to be competent and self-reliant. Furthermore, she insisted that the idea of a solo circumnavigation was hers alone.

No matter how much youth sailing records are discouraged, there will probably be youngsters who will continue to try to set them. As *Latitude* correctly points out, that doesn't make it right. But when there is a person of competence, such as Laura, she should be recognized for her accomplishment.

I first saw Dekker from afar at Durban, South Africa. The marina gate-keepers pointed out her 38-ft Jeanneau Gin Fizz *Guppy* to me. "Did you know," they said with reverence and wide eyes, "that a 16-year-old girl sailed that boat all the way across the Indian Ocean by herself?" It had taken 47 days, and she'd previously sailed across the Atlantic and the Pacific oceans. I actually wasn't aware of these accomplishments at the time, as I'd been sailing myself and hadn't followed her story.

During the next weather window, my crew and I sailed down



COURTESY JOHN COLBY

**John Colby enjoyed helping Laura during her stay in South Africa.**

the coast to Port Elizabeth, where we ended up berthing next to Dekker and *Guppy* at the yacht club. Since we'd rented a car to visit the Addo Elephant Preserve, I asked Laura, who hadn't visited any preserves, if she wanted to come with us.

It wasn't long before Laura took over the car navigator's job from my crew Craig, who was bungling it. When Laura later asked me if I thought it was safe for her to walk from the yacht club into town, I decided to err on the side of caution by saying no. The result was that I spent several days taking her shopping, to internet cafes, and to do laundry. She even ended up hanging out and having dinners aboard my boat — and always had second helpings. She even





**DISCOVER THE DIFFERENCE**

**On the Water:**

**37° 54' 45" N 122° 21' 00" W**

**Online:**

**[www.MarinaBayYachtHarbor.com](http://www.MarinaBayYachtHarbor.com)**

**Deep Draft • (510) 236-1013 • Great Location**

Yacht owners trust

## Pacific Crest Canvas

for the best in design, service and quality.



We strive to make our products the  
**Highest Quality at the Best Prices**

Specializing in:

### Baja Awnings

Lightweight and waterproof  
Durable and easy to launch  
Multiple side screen configurations

### Coastal Dodgers

Affordable designs  
High quality materials  
Superior workmanship

### Cruiser's Awnings

Easy setup off your dodger  
Flies with no bulky frame  
Includes shade screens

### Offshore Dodgers

Welded aft handrail  
Bolt-on side handrails  
Lexan windshields



[www.pacificcrestcanvas.com](http://www.pacificcrestcanvas.com)

Located in Grand Marina      Open Mon.-Fri. 8-4  
2021 Alaska Packer Pl, Ste 13      Sat. by appointment  
Alameda, CA 94501                      510-521-1938

## LETTERS

joined four Americans and three Germans for Thanksgiving dinner.

As *Latitude* has often said, one of the great things about cruising is that great friendships are made very quickly, despite diverse backgrounds and age differences. Like most friendships, particularly those with a 48-year age difference, Laura's



**John reports Laura was a typical teenager, finding "adult" activities boring and annoying.**

and mine is based on mutual respect. There is no question that Laura is a teen, as she finds certain adult things to be "boring" or "annoying."

However, when topics such as sailing, passagemaking and weather at sea come up, her whole demeanor changes. She becomes serious and her voice lowers. It's as if she's suddenly transformed into a mature sailor.

Laura's upbringing has not been ideal, as her parents — who were independent by their mid-teens — moved around a lot. Laura was born in New Zealand, but even though she hasn't lived there in many years, she flies the Kiwi flag on *Guppy*. When asked where she considers home, "*Guppy*" was her answer. Few of us would want our children to have had her upbringing.

But if Laura is under pressure — and she certainly is — it is self-imposed. She just wants to finish the damn trip so she can be free to take crew with her if she wants.

There is no question that Laura's youth record attempt generates interest. *Guppy* was initially asked to dock next to the Volvo Race boats in Cape Town. But she was asked to move her boat after it drew more attention than did the Volvo boats. But she was invited — and she accepted — to do a day race aboard one of the Volvo boats.

Laura is a public relations person's nightmare. When the Port Elizabeth YC secretary told her that a local television person wanted to see her, Laura had a one-word response: "No!" Laura does sell a weekly column to a Dutch newspaper, and Santa Cruz documentary film maker Jillian Schlesinger meets her at various ports around the world to get footage. But the local press interest in ports can be overwhelming, and even her documentary crew frustrates her. One of the first things she told me in Simon's Town was what a pain it was to have a cameraman and sound guy around.

Laura and I left Port Elizabeth together, and initially motorsailed into winds that gusted to 28 knots when leaving the large bay. Laura told me over the VHF that water was somehow coming in, and her main salon cushions and books had gotten soaked. "But I'm okay!" she added in a cheerful voice. The next day she tore away some paneling and found the source of the leak under the amidships cleat. A cleat had been torn loose by the heavy surge in Port Elizabeth. She got out the sealant and fixed it.

Laura told me that while in the Indian Ocean, one of the ubiquitous southern swells had collided with other swells to knock *Guppy* down and fill her cockpit. There was no panic or concern on Laura's part. She simply got her camera and filmed the water sloshing around until it drained out. Laurence Gonzales, the author of *Deep Survival*, would probably call Laura the ultimate survivalist, as she is able to step



Northern California

# Boat Fest

Marina Village Yacht Harbor  
Alameda, California

**March 1-4** 2012

**Thu & Fri: 12-5 • Sat & Sun: 11-5**

**Winter Sales Event &  
Boating Celebration  
for the Whole Family!**  
Free Admission & lots of Free Parking

- Power & Sail
- New & Used
- 100+ Yachts For Sale
- Seminars
- Marine Exhibits
- Music & Food

For complete information

[www.BoatFestival.BlogSpot.com](http://www.BoatFestival.BlogSpot.com)



**South Beach Harbor is a great way to experience San Francisco. Boats of all sizes are welcome in our protected deepwater harbor. Bring your boat to South Beach and enjoy all the attractions of the city.**



- Two guest docks for boats up to 125'**
- 20 guest berths up to 50'**
- Casual and fine dining nearby**
- Adjacent to AT&T Park**
- Easy access to transportation**
- 24 hour security**
- Free pump-out stations**



**For Reservations:**  
415.495.4911 (x1111)  
fax: 415.512.1351  
sb.harbor@sfgov.org  
www.southbeachharbor.com

## LETTERS

outside problems and not be overwhelmed by them.

I write this several days before Christmas and note that Laura will be alone at sea on Christmas Day as well as New Year's Day. That is determination!

I think her around-the-world goal and sailing is carrying her through adolescence with flying colors. And her competence and knowledge are carrying her safely around the world. Even old guys have had childhood dreams of sailing around the world. Some are just able to fulfill those dreams at an earlier age.

John Colby  
Iris, Hylas 42  
Portland, OR

*John — Thanks for the interesting first-hand report. We think we can all agree that what Laura has accomplished is tremendous. Yet it's not something we're going to go out of our way to celebrate or encourage. There are three reasons:*

*1) Such stunts — and we do consider them to be stunts — will merely encourage ever-younger kids in search of fame and money. And at what age do child sailors become 'too young'? Is it twelve? Ten? Seven? 2) We don't believe someone in their mid-teens has the mental capacity or life experience to intelligently evaluate whether a solo circumnavigation is a risk worth taking. And 3) what do age-based sailing records prove anyway? We'll grant you confidence, determination and perseverance. On the other hand, we'll wager that any number of junior sailors could sail circles around a lot of the age-based record holders and record seekers. The thing that would impress us is if any of the age-based record holders, at age 18, were able to demonstrate superior sailing skills in head-to-head competition — say a 1,000-mile singlehanded race — with their peers.*

*You describe Dekker as the "ultimate survivalist" because she was calm enough to film water draining out of her cockpit after a knockdown and because she was brave — or whatever — enough to be offshore on Christmas and New Year's Day? Give us a break. Ultimate survival is being able to remain calm enough to live through a crossfire when outnumbered in Afghanistan. Or when you have to gnaw your arm off to get free of a boulder that's trapped you during a solo climb in the middle of nowhere. Or when you grow up in some violence-torn, drought-ridden Third World country where there isn't enough food to eat.*

*Yes, we're impressed with what Dekker has done, but there's no way of knowing whether any number of her sailing peers could have done the same thing. For the record — pardon the bad pun — the World Speed Sailing Record Council does not recognize age-based sailing records. Neither does the Fédération Aéronautique Internationale, which oversees aviation records.*

### ↑↓ THE WORLD ACCORDING TO LATITUDE

I want to thank *Latitude* for not hyping teens setting age records for sailing around the world. You have a great outlook on sailing and life in general. Thanks for being out there.

Pat Gilhooly  
Corpus Christi, TX

*Pat — Thank you. That said, we want to remind everyone that we just express our opinions; it's not as if we're handing down Gospel Truth from on high. So feel free to rip into us.*

### ↑↓ "GIMME A BIG MAC"

I took the accompanying photo of a MacGregor 65 rotting away in Moss Landing. Didn't she belong to boatyard owner





# Paradise Village™ MARINA

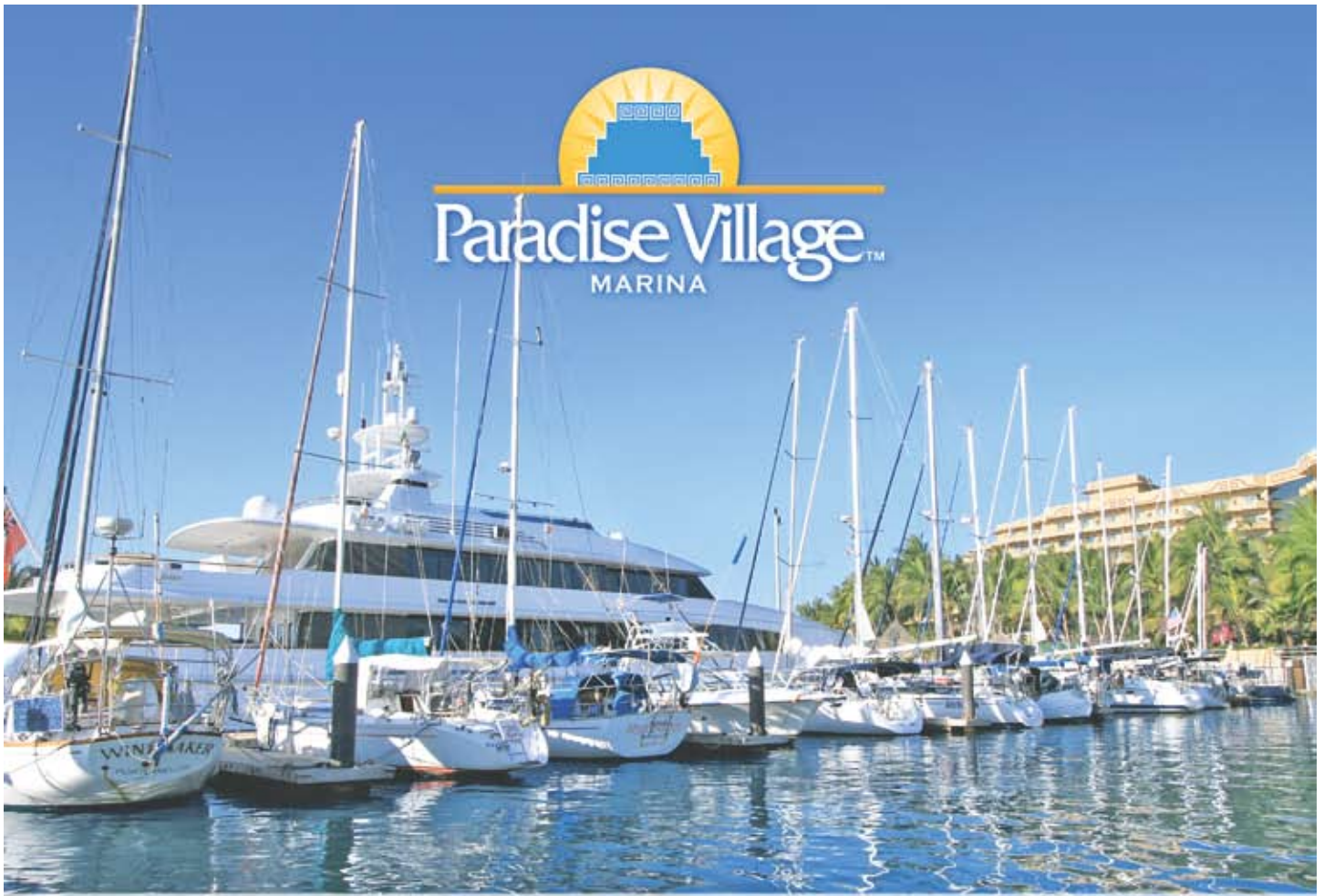

*Voted best Marina in Mexico*

## *Services:*

- Electrical service, 110/30 amps
- 220/50 amps, 3 phase 100 amps and 3 phase 480v
- Crystal Clear Potable Water
- Cable TV
- Garbage Collection
- Pump - out Station
- Fire Fighting Boat Protection
- 24 Hrs. Security
- Computerized gate access

## *Additional Services:*

- Vallarta Yacht Club
- Special area for marina guests
- Restrooms
- Lockers
- Showers
- Pool and jacuzzi
- Free access to all the facilities of our 5 star hotel
- White sand beach
- Dive tank refilled
- Propane refill
- Launch ramp

*World Class Marina*  
[www.paradisevillage.com](http://www.paradisevillage.com)



CONTACT US: [marina@paradisevillagegroup.com](mailto:marina@paradisevillagegroup.com)  
Phone & fax from U.S. 011-52-322-22-66728 · GPS Coordinates: 105° 17.9 W 20° 41.2 N



Vallarta Yacht Club



**Gobius<sup>4</sup>**  
Level  
indicator

Installs and  
measures from  
the outside

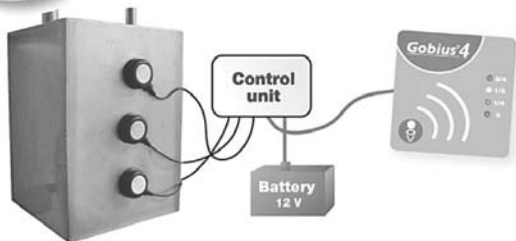

### Do you know how full... or empty your tanks are?

Gobius will tell you... no matter what material your tanks are.  
Simple, easy installation... no holes to drill.  
Low energy consumption... only 40 mA.  
Installed in 30 minutes.  
Patented system.



**AB**  
MARINE

747 Aquidneck Ave.  
Middletown, RI 02842

**401-847-7960**  
Fax: 401-849-0631

sales@ab-marine.com  
[www.ab-marine.com](http://www.ab-marine.com)

## SHAFT SHARK

**The best rope,  
line and debris  
cutter there is!**

Two piece unit

For both power and sail

**Now available for  
sail drive systems.**

**AB**  
MARINE

747 Aquidneck Ave.  
Middletown, RI 02842

**401-847-7960**  
Fax: 401-849-0631

sales@ab-marine.com  
[www.ab-marine.com](http://www.ab-marine.com)

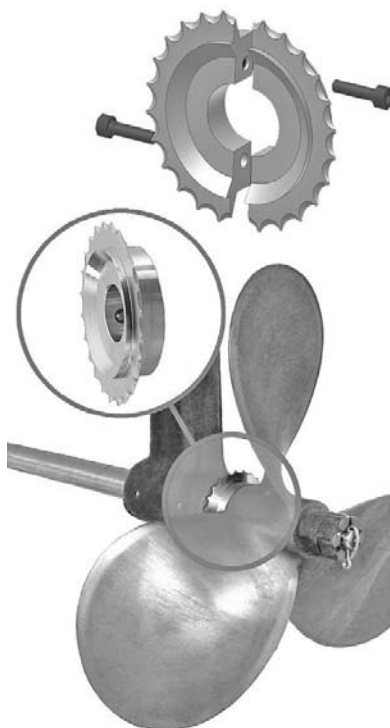

## LETTERS

Hal Nelson back in the '80s? Who would let a boat go like this?

Tom Van Dyke  
en pointe, Searunner 31  
San Francisco



TOM VAN DYKE

**Could this really be Hal Nelson's old MacGregor 65? The answer is no.**

Tom — According to Carl Nelson, that is/was not his father's old Black-jack, which Hal modified as heavily as he raced her. Since the 65s were built of fiberglass, it's unlikely Andiamo is "rotting away." In fact, there may be a deal there some-

where for a person with an abundance of elbow grease.

The Mac 65s hit the yachting industry like a bombshell when introduced in the '80s, as they originally sold for about \$115,000 — or about what just the raw materials were rumored to cost for a Santa Cruz 50. Approximately 100 of the 'Big Macs' were built during the eight-year run that ended in '95. Improbably, production of the 65s was stopped not because of lack of buyer demand, but rather to dedicate the entire five-acre MacGregor site to building the water-ballasted, trailerable MacGregor 26Ms, for which there was insatiable demand.

Criticized by some as being lightly built, the skinny Mac 65s nonetheless established some important race records, even in head-to-head competition with more expensive and highly regarded Santa Cruz and N/M 70s. In '85, for instance, Dick and Camille Daniels's Joss averaged 10.5 knots for 1,150 miles to beat all competitors in the Los Angeles to Puerto Vallarta

Race. Five of the first seven boats to finish that race were Mac65s. Joss's record stood for 19 years — nearly an eternity — before being eclipsed by Doug Baker's Long Beach-based Andrews 80 Magnitude 80.

While the stock 65s perhaps weren't rugged enough for extensive rough-weather racing, the Mac 65s were popular with their owners. We know of one fellow who bought a regular model because he couldn't wait to take delivery of his ordered pilothouse version, and happily ended up owning two of them.



COURTESY MACGREGOR YACHTS

**The new MacGregor 70 'Anthem' is ready to sail away for \$250K.**

If we're not mistaken, singlehander Hans Vielhauer of Sonoma did a circumnavigation with a Mac65 before passing. And after some Ha-Ha's and cruising in Mexico, Bob Callaway of Pleasant Harbor, WA, did a Puddle Jump and is apparently still cruising the South Pacific with Braveheart.

According to the MacGregor website, consideration is being given to reintroducing the 65, but in a version lengthened to 70 feet and fitted with a ketch rig. Two have been built, including the company's Anthem, which apparently beat legendary sleds Merlin and Ragtime to the finish line of the Ensenada Race.

MacGregor Yachts was started by Roger MacGregor as part of a Stanford University MBA project in the '60s. The company has subsequently sold over 36,000 sailboats, most of them in smaller sizes, under the Venture and MacGregor brands.



MARINE TRAVELIFT®



**VOLVO PENTA**

### Exceptional Service, Remarkable Results

You don't go to a boatyard because of how it looks, you go for results. Our attention to detail, product knowledge and customer satisfaction will make you a return customer...and we think you'll like the way it looks, too.

*Contact us today!*



310 W. Cutting Blvd. Pt. Richmond, CA 94804 · 510 · 237 · 0140 · baymarineboatworks.com

Stay in touch with us at [facebook.com/baymarineboatworks](https://facebook.com/baymarineboatworks)



**West Marine®**  
**Rigging Service**

# Your Sailing Resource!

- Specialty Hardware
- Technical Apparel



Visit [westmarine.com](http://westmarine.com) to shop our  
**New One Design** offerings

## Your Complete Rigging Source!

Installation • Lifelines • Running Rigging  
Standing Rigging • Dock & Anchor Lines

Mobile Rigging Service Available

**SCHAEFER**  
**MARINE**

**FSE/ROBLING**  
WORLD CLASS YACHTING ROPES

**RONSTAN**

**POWERLITE**  
RIB RIGGING

**Johnson**  
Marine Hardware

**NEW ENGLAND ROPES**  
TOGETHER IN MOTION

**samson**

**facnor**  
FURLING SYSTEMS

**Hayn Marine**

**holmatro**  
MARINE EQUIPMENT

**SmartRigging**  
The Intelligent Choice

**HARKEN**

**FORESPAR**

Contact us for all of your Rigging Needs!  
**888-447-RIGG**

or visit our Onsite Rigging Locations in:

**Alameda, CA** **San Diego, CA** **Seattle, WA**  
730 Buena Vista Ave. 1250 Rosecrans St. 1275 Westlake Ave. N  
(510) 521-4865 (619) 255-8844 (206) 926-0361

[westmarine.com/rigging](http://westmarine.com/rigging)

## LETTERS

### ↑↓ ANOTHER TAKER FOR A SOCAL HA-HA

I'm hoping you've gotten lots of positive response to your October editor's note saying that you would put on a SoCal Ha-Ha if 30 boats were interested. Count us in!

Mike Leneman of MultiMarine hosts a Summer Splash to Catalina from various Southern California ports each September. Last year we had 30 boats, including some large cats and tris. A few of us did some extra Channel Islands ex-



JEFF DUNNAVENT

**'Origami' is ready to roll for a SoCal Ha-Ha.**

ploring before the event and, while anchored off Santa Rosa Island, discussed the fact that the South Coast needs a proper rally event to take advantage of late summer weather and the great National Park. I've spoken with Mike, and he said he'd be happy to coordinate his Splash efforts with a SoCal Ha-Ha, if you're game.

If a SoCal Ha-Ha is really in the works, I'd rally the ocean-going contingent of the Bay Area Multihull Association (BAMA), as it would be a great event for many California sailors who just can't take enough time off to do a Baja Ha-Ha. And count me in as a volunteer to help bring such an event to life.

Greg Carter  
*Origami, F27*  
Sausalito

Greg — Thanks for the offers. There seems to be enough interest, so we're making inquiries with various harbors and government agencies to see what obstacles there might be. Right now we're waiting to learn when Santa Barbara plans to start the dock renovations at Marina 1, which would all but tie up that harbor.

In any event, we'll be happy to coordinate — or at least not conflict — with Mike's Summer Splash, an event we've always wanted to do. We'll keep you posted.

### ↑↓ WANT TO PLAY IT SAFE? THEN STAY AT HOME

As many *Latitude* readers know, Pamela Habek and I were the first two legally blind people to not only do the Ha-Ha, but to sail across the Pacific. The main reason we didn't continue

farther was due to the risk of Pam losing all of her vision after she suffered a sudden torn retina while we were in Vanuatu. It was very difficult for her to quit our attempt at a circumnavigation, but it was the right decision for her.



COURTESY SCOTT DUNCAN

**Pam and Scott assumed the risk of adventure.**

There are many things that trouble me on both sides of the Dennis Howard/Coast Guard incident, but the greatest of these is 'able-bodied' people saying that disabled people should not be allowed to undertake such challenges because it will cost taxpayers money. Any transoceanic voyage is dangerous. It is exactly the challenge and the thrill of the danger that calls so many of us to assume those risks of adventure. If people want to play it safe, they should stay home and huddle in the corner playing Wii.

I only hope that other modern-day adventurers will con-





**Interlux**

Our World is Water

## Generations of boaters can't be wrong

Passing down the lessons from years of experience is invaluable. Technique, discipline and a trust in the right materials are essential for great results you can be proud of.

But taking a leap of faith to a different product can be the hardest part.

With over 100 years experience in the science of boat care, our varnishes have been specially formulated to provide the best treatments available for your boat. So that leap of faith is really just one small step - towards the fantastic finish and high level of protection you demand.

Whether traditional tung oil varnish, urethane alkyd or extended performance with two-part polyurethane, we have a range of options. Contact us today or visit [www.yachtpaint.com](http://www.yachtpaint.com)

Apply the Interlux heritage to the whole of your boat. No matter how big or small. Interlux Varnish - be more than proud.



Find us on Facebook



**AkzoNobel**



# LEARN TO SAIL & GO SAILING!!

Learn to safely skipper boats up to 34' with four full weekends of training and become US SAILING certified to charter modern cruising sailboats.

## - PACKAGE INCLUDES -

- US SAILING Basic Keelboat Certification Class
- US SAILING Basic Cruising Certification Class
- Bay Cruising Destination Workshop
- One Year US SAILING Membership

## - PLUS -

- **A FULL SET OF WEST MARINE FOUL WEATHER GEAR TO KEEP YOU WARM & DRY!**
- **INCLUDED CLUB NAUTIQUE MEMBERSHIP GETS YOU SAILING FOR 40% LESS!**
- **MONTHLY DUES PAID THROUGH MARCH**

Purchased separately - \$3,326!

**Winter Special  
ONLY \$1,595!**

**SAVINGS OF OVER 50%!**



You're at the helm!

**Call Today!**  
Alameda 800-343-SAIL  
Sausalito 800-559-CLUB  
**Club Nautique**  
www.clubnautique.net

## LETTERS

tinue to push the limits in life, even if it is dangerous. After all, this is how Edmund Hillary made it to the summit of Everest, how America placed a flag on the moon, and yes, even how Pam and I stepped onto a dock in Sydney Harbour to hoist a well-deserved schooner of beer.

On a personal note, you may soon see me singlehanded across the Atlantic on a very small boat. The bug has bitten me.

Scott Duncan  
Disability Program Analyst  
U.S. Department of State  
Washington, D.C.

*Scott — Without casting judgment on the Howard case or what you and Pamela accomplished, you don't really believe that all transoceanic voyages are of equal risk, do you? We think the skill of the skipper and crew, the preparation of the boat, and the quality of the construction and maintenance have a lot to do with how voyages turn out. Consider the case of modern 950-ft cruise ships that take thousands of passengers from one great Med port to another. What could possibly go wrong with one of them? Er, wait a minute, maybe that's not such a good example.*

*Our philosophical position is that people who are old enough to understand the risks of more extreme adventures should be able to assume them — as long as they don't count on taxpayers to go to extreme expense to save them or to take over the cost of raising their orphaned children.*

### ↑↓ **OBAMA, ABORTION AND THE ECONOMY ARE ALL THE FAULT OF THE BIKINI**

I found your comments in the January 6 'Lectronic about the four models wearing retro bathing suits for publicity at the opening of the London Boat Show to be worth thinking about. As usual, you prefer to see a maximum amount of female flesh. But you might want to think about this: When the more modest retro-style of bathing suit was the norm, say in the late '40s and '50s, this country was near its peak, socially, morally and in terms of personal happiness. Then came the bikini, which you love so dearly. And what do we have today? Legal murder by abortion, same sex marriage, Obama, perverts, overcrowded jails, an economic mess like never before, and unemployment without solution.

I think that I would prefer a little less skin and a little more morality.

Robert Lockwood  
Celebration, Gulfstar 50  
Alameda



WEBB LOGG

**This isn't as sexually stimulating as it is beautiful.**

*Robert — Fascinating letter. When it comes to bathing suits, our personal preference is for whatever suit best complements a woman's physique and personality, and which she's most comfortable wearing. Since the brain is the biggest and most potent sex organ, more skin certainly doesn't necessarily equate to more stimulation, at least for us. For example, we don't find sleek 20-year-old French girls frolicking in the surf at St. Barth wearing only tiny bikini bottoms to be sexually stimulating, but rather marvelous celebrations of nature and youth. We admire them in the same way we admire beautiful flowers.*





**www.marina-mazatlan.com**

468 slips from 30 to 260 feet length  
125/250 V 30, 50, 100 Amps.



For all reservation and details  
Contact: [atec@marina-mazatlan.com](mailto:atec@marina-mazatlan.com)  
Phone: 011 52 669 916 77 99  
Phone & fax: 011 52 669 669 2937  
Real Estate  
[www.marina-mazatlan.com](http://www.marina-mazatlan.com)

**2012**  
**Summer Special Package!**  
Stay 5 months from June 1st to October 31st, 2012

**at USD \$ 0.24 cents per foot per day**  
plus 16% tax  
**Boat must be here from June 1st to October 31st, 2012.**  
*(metered power extra)*

**2012 WINTER CRUISING RATES:  
NOV. 1 2011. THRU MAY 31 2012.**

SIZE OF BOAT	0' TO 41'	42' TO 60'	61' TO 90'	90' OVER
TIME OF STAY				
01 TO 07 DAYS	\$ 0.95	\$ 1.05	\$ 1.40	\$ 1.80
08 TO 29 DAYS	\$ 0.60	\$ 0.70	\$ 1.00	\$ 1.30
30 TO 90 DAYS	\$ 0.43	\$ 0.61	\$ 0.70	\$ 1.00
91 DAYS OR MORE	\$ 0.36	\$ 0.43	\$ 0.50	\$ 0.60

**RATES, IN U.S. DOLLARS, ARE BASED ON DOCUMENTED LENGTH AND DO NOT INCLUDE 16 % TAX. 30 FOOT MINIMUM CHARGE.**

Harbor Master : Jaime Ruiz email: [jaimeruiz@marina-mazatlan.com](mailto:jaimeruiz@marina-mazatlan.com)



# No Time to Waste

## Boat Show Pricing Good Until Feb. 11 2012

Find Sidecar Sally at [boatelectric.com](http://boatelectric.com)  
and Follow her to our  
Shopping Cart  
/Catalog and Save  
Every day.



**BOAT ELECTRIC** Helping you cruise in comfort since 1968  
(206) 281-7570 • (800) 458-5680  
[www.boatelectric.com](http://www.boatelectric.com)  
2520 Westlake Ave. N. • Seattle, WA 98109

## Come Join The Fun

Special Pricing For  
Slips In Our Marina



16+ Cruise-Outs/Year  
Host 25 Races/Year  
20+ Social Events/Year  
Full Dining/Bar  
OYC Owns 220 Slips

### Oakland Yacht Club

in Alameda, CA Est. 1913

Call For A Tour Of Our Clubhouse And Marina

[www.oaklandyachtclub.com](http://www.oaklandyachtclub.com)

(510) 522-6868

## LETTERS

*But if we had to pick a favorite suit for an even slightly older woman, it would be a more sophisticated sleeveless one-piece black suit cut high in the thighs to accentuate the legs' length, but also have a nearly turtleneck collar that says the woman is confident enough in her ability to attract attention without feeling the need to resort to 'working the rack'. She might not be the first woman in a crowd who would attract our attention, but all things being equal, she would likely get more appreciative and lasting attention.*

*While we agree with your assessment that civilization is in a downward spiral, we don't agree that the bikini is the cause, or that the things you cited are evidence of the decline. In our estimation, it's the insatiable lust most people have for money, and the almost universal infestation of corruption at all levels of government, that are both the main causes and primary evidence of the decline.*

### ↑↓ THE SOUND OF TWO GROWN MEN GIGGLING

In the late '80s I helped deliver *Nadejda*, a 60-ft steel boat from Moss Landing to San Diego. The Colin Archer design was beautifully outfitted and, because of her great beam, was larger down below than most houses in Pacific Grove. And the aft master stateroom featured a claw-foot bathtub, with a hatch above to keep things from becoming too steamy.

In any event, we departed Monterey Bay in a northwesterly gale and heavy following seas. The weather conditions weren't a concern since the boat was such a tank, but two of the crew became too ill to stand watch for the first leg. Once we rounded Conception and reached flat water, my shipmates miraculously perked up and gave me some needed relief from the helm. At that point Jay, the owner and skipper, invited me to take advantage of the luxury of a bath as a reward for my having stood extra watches. I was all for it, as I had never taken a fresh water shower on a boat before, much less a hot bath!

After easing myself into the warm and soapy water, I closed my eyes and felt a sense of complete relaxation. But it didn't last long. Although I'd heard the sound of two grown men giggling, I didn't open my eyes in time to see the five gallons of icy sea water being dumped down the hatch and onto my head.

Thanks, Jay and Mike; those were good times. But just remember, revenge is best served cold.

Brian Ackerman  
West Wind, 1927 Monterey Clipper  
Moss Landing

### ↑↓ KEEPING THE ADMIRAL HAPPY WITH A BATHTUB

We have a bathtub — or what I call a 'sitz tub' aboard our Deerfoot 62 cutter *Moonshadow*. It is a bit shorter than a home-sized bath, has higher sides, and has a step on one end that is perfect for sitting on. In theory, one could have a relaxing bubble bath in it, but out of reverence for the hard work our watermaker has to do, we've never indulged.

Ironically, the thing we really appreciate about the tub is that it's perfect for taking a shower. You see, we shower every day, no matter if we're on the hook or on a passage. We encourage our crew to do the same. When it's rough, the tub comes in handy because the person taking the shower can sit down and wedge himself in while showering. This can be done even when a stand-up inside shower or a deck shower might be untenable. The tub also helps keep the water going where it should — down the drain as opposed to all over the furniture in the head.

When partially filled, the tub has an endless number of



# FOR THE RECORD

## 2011

- IRC 2... 1st
- RC 44... 1, 2, 3
- Melges 32... 1st
- J/105... 1st\*
- Corsair 28R... 1st
- PHRF 1... 1st
- 2011 Race 2011**
- Barn Door... 1st
- Sleds... 1st
- Aloha Division... 1st
- Division 1... 1, 2
- Division 2... 1st\*
- Division 4... 1st\*
- Division 6... 1st\*
- 2011 Race 2011**
- Line Honors... 1st
- IRC 1... 1, 2
- 2011 Race 2011**
- Mackinac Cup Overall... 1st
- Beneteau 40.7... 1, 2
- CR 1... 1st
- CR 2... 1st
- DBL Handed... 1, 2
- J/109... 1, 2, 3
- Sec 1... 1st
- Sec 2... 1st
- Sec 3... 1, 2, 3
- Sec 4... 1, 2
- Sec 6... 1, 2, 3
- Turbo... 1, 3
- Multi... 1, 2, 3
- Canada's Cup... 1st**
- 2011 Race 2011**
- Offshore... 1, 3
- MAC Cruising... 1st
- T-10... 1, 2
- Farr 40... 1st
- J/105... 1, 2
- Beneteau 36.7... 1, 2
- Beneteau 40.7... 1, 2
- J/111... 1st
- 2011 Race 2011**
- San Juan 24... 1, 2, 3
- J/109... 1, 2, 3
- J/105... 1, 3
- J/80... 1, 2
- Performance 30... 1, 3
- J/24... 1, 2
- 2011 Race 2011**
- Class 1... 1, 2, 3
- Multihull... 1, 2
- Class 0... 1, 2, 3

## PHRF Full Regatta

- Over 124... 2, 3
- Under 125... 1, 3
- M24x... 1st
- Cal 20... 1, 2, 3
- 2011 Race 2011**
- PHRF A... 1, 2
- M24x... 1st
- Cal 20... 1, 2, 3
- PHRF B... 1, 2, 3
- 2011 Race 2011**
- Overall... 1st
- Beneteau 36.7... 1st
- Beneteau 40.7... 1, 2
- GL 36... 1, 3
- GL 70... 1, 2
- Level 35... 1, 3
- J/111... 1st
- PHRF 1... 1, 3
- PHRF 2... 1st
- PHRF 3... 1st
- Long Distance Class... 1, 3
- 2011 Race 2011**
- Overall & IRC Class 1... 1st
- 2011 Race 2011**
- IRC A... 1st
- Melges 24 Nationals... 1, 2, 3
- Melges 32 Worlds... 1, 2, 3
- Swan C of Britain Challenge
- Swan 42... 1st
- 2011 Race 2011**
- Class C... 1st
- 2011 Race 2011**
- IRC Super 0... 1st
- 2011 Race 2011**
- IRC A... 1, 2
- IRC B... 1st
- IRC D... 1st
- J/120... 1st
- IRC B... 1st
- 2011 Race 2011**
- PHRF B... 1, 2, 3
- PHRF C... 1, 2, 3
- PHRF D... 1, 2, 3
- PHRF E... 1, 3
- PHRF F... 1, 2
- NFS... 1, 2
- Class 0... 1, 3
- Class 2... 1st
- Class 3... 1, 2
- Class 4... 1, 2
- Class 5... 1st
- Class 6... 1, 2, 3
- SJ24... 1, 2, 3

## PHRF Full Regatta

- Over 124... 2, 3
- Under 125... 1, 3
- M24x... 1st
- Cal 20... 1, 2, 3
- 2011 Race 2011**
- PHRF A... 1, 2
- M24x... 1st
- Cal 20... 1, 2, 3
- PHRF B... 1, 2, 3
- 2011 Race 2011**
- Overall... 1st
- Beneteau 36.7... 1st
- Beneteau 40.7... 1, 2
- GL 36... 1, 3
- GL 70... 1, 2
- Level 35... 1, 3
- J/111... 1st
- PHRF 1... 1, 3
- PHRF 2... 1st
- PHRF 3... 1st
- Long Distance Class... 1, 3
- 2011 Race 2011**
- Overall & IRC Class 1... 1st
- 2011 Race 2011**
- IRC A... 1st
- Melges 24 Nationals... 1, 2, 3
- Melges 32 Worlds... 1, 2, 3
- Swan C of Britain Challenge
- Swan 42... 1st
- 2011 Race 2011**
- Class C... 1st
- 2011 Race 2011**
- IRC Super 0... 1st
- 2011 Race 2011**
- IRC A... 1, 2
- IRC B... 1st
- IRC D... 1st
- J/120... 1st
- IRC B... 1st
- 2011 Race 2011**
- PHRF B... 1, 2, 3
- PHRF C... 1, 2, 3
- PHRF D... 1, 2, 3
- PHRF E... 1, 3
- PHRF F... 1, 2
- NFS... 1, 2
- Class 0... 1, 3
- Class 2... 1st
- Class 3... 1, 2
- Class 4... 1, 2
- Class 5... 1st
- Class 6... 1, 2, 3
- SJ24... 1, 2, 3

## PHRF Full Regatta

- Over 124... 2, 3
- Under 125... 1, 3
- M24x... 1st
- Cal 20... 1, 2, 3
- 2011 Race 2011**
- PHRF A... 1, 2
- M24x... 1st
- Cal 20... 1, 2, 3
- PHRF B... 1, 2, 3
- 2011 Race 2011**
- Overall... 1st
- Beneteau 36.7... 1st
- Beneteau 40.7... 1, 2
- GL 36... 1, 3
- GL 70... 1, 2
- Level 35... 1, 3
- J/111... 1st
- PHRF 1... 1, 3
- PHRF 2... 1st
- PHRF 3... 1st
- Long Distance Class... 1, 3
- 2011 Race 2011**
- Overall & IRC Class 1... 1st
- 2011 Race 2011**
- IRC A... 1st
- Melges 24 Nationals... 1, 2, 3
- Melges 32 Worlds... 1, 2, 3
- Swan C of Britain Challenge
- Swan 42... 1st
- 2011 Race 2011**
- Class C... 1st
- 2011 Race 2011**
- IRC Super 0... 1st
- 2011 Race 2011**
- IRC A... 1, 2
- IRC B... 1st
- IRC D... 1st
- J/120... 1st
- IRC B... 1st
- 2011 Race 2011**
- PHRF B... 1, 2, 3
- PHRF C... 1, 2, 3
- PHRF D... 1, 2, 3
- PHRF E... 1, 3
- PHRF F... 1, 2
- NFS... 1, 2
- Class 0... 1, 3
- Class 2... 1st
- Class 3... 1, 2
- Class 4... 1, 2
- Class 5... 1st
- Class 6... 1, 2, 3
- SJ24... 1, 2, 3

## PHRF Full Regatta

- Over 124... 2, 3
- Under 125... 1, 3
- M24x... 1st
- Cal 20... 1, 2, 3
- 2011 Race 2011**
- PHRF A... 1, 2
- M24x... 1st
- Cal 20... 1, 2, 3
- PHRF B... 1, 2, 3
- 2011 Race 2011**
- Overall... 1st
- Beneteau 36.7... 1st
- Beneteau 40.7... 1, 2
- GL 36... 1, 3
- GL 70... 1, 2
- Level 35... 1, 3
- J/111... 1st
- PHRF 1... 1, 3
- PHRF 2... 1st
- PHRF 3... 1st
- Long Distance Class... 1, 3
- 2011 Race 2011**
- Overall & IRC Class 1... 1st
- 2011 Race 2011**
- IRC A... 1st
- Melges 24 Nationals... 1, 2, 3
- Melges 32 Worlds... 1, 2, 3
- Swan C of Britain Challenge
- Swan 42... 1st
- 2011 Race 2011**
- Class C... 1st
- 2011 Race 2011**
- IRC Super 0... 1st
- 2011 Race 2011**
- IRC A... 1, 2
- IRC B... 1st
- IRC D... 1st
- J/120... 1st
- IRC B... 1st
- 2011 Race 2011**
- PHRF B... 1, 2, 3
- PHRF C... 1, 2, 3
- PHRF D... 1, 2, 3
- PHRF E... 1, 3
- PHRF F... 1, 2
- NFS... 1, 2
- Class 0... 1, 3
- Class 2... 1st
- Class 3... 1, 2
- Class 4... 1, 2
- Class 5... 1st
- Class 6... 1, 2, 3
- SJ24... 1, 2, 3

## PHRF Full Regatta

- Over 124... 2, 3
- Under 125... 1, 3
- M24x... 1st
- Cal 20... 1, 2, 3
- 2011 Race 2011**
- PHRF A... 1, 2
- M24x... 1st
- Cal 20... 1, 2, 3
- PHRF B... 1, 2, 3
- 2011 Race 2011**
- Overall... 1st
- Beneteau 36.7... 1st
- Beneteau 40.7... 1, 2
- GL 36... 1, 3
- GL 70... 1, 2
- Level 35... 1, 3
- J/111... 1st
- PHRF 1... 1, 3
- PHRF 2... 1st
- PHRF 3... 1st
- Long Distance Class... 1, 3
- 2011 Race 2011**
- Overall & IRC Class 1... 1st
- 2011 Race 2011**
- IRC A... 1st
- Melges 24 Nationals... 1, 2, 3
- Melges 32 Worlds... 1, 2, 3
- Swan C of Britain Challenge
- Swan 42... 1st
- 2011 Race 2011**
- Class C... 1st
- 2011 Race 2011**
- IRC Super 0... 1st
- 2011 Race 2011**
- IRC A... 1, 2
- IRC B... 1st
- IRC D... 1st
- J/120... 1st
- IRC B... 1st
- 2011 Race 2011**
- PHRF B... 1, 2, 3
- PHRF C... 1, 2, 3
- PHRF D... 1, 2, 3
- PHRF E... 1, 3
- PHRF F... 1, 2
- NFS... 1, 2
- Class 0... 1, 3
- Class 2... 1st
- Class 3... 1, 2
- Class 4... 1, 2
- Class 5... 1st
- Class 6... 1, 2, 3
- SJ24... 1, 2, 3

## PHRF Full Regatta

- Over 124... 2, 3
- Under 125... 1, 3
- M24x... 1st
- Cal 20... 1, 2, 3
- 2011 Race 2011**
- PHRF A... 1, 2
- M24x... 1st
- Cal 20... 1, 2, 3
- PHRF B... 1, 2, 3
- 2011 Race 2011**
- Overall... 1st
- Beneteau 36.7... 1st
- Beneteau 40.7... 1, 2
- GL 36... 1, 3
- GL 70... 1, 2
- Level 35... 1, 3
- J/111... 1st
- PHRF 1... 1, 3
- PHRF 2... 1st
- PHRF 3... 1st
- Long Distance Class... 1, 3
- 2011 Race 2011**
- Overall & IRC Class 1... 1st
- 2011 Race 2011**
- IRC A... 1st
- Melges 24 Nationals... 1, 2, 3
- Melges 32 Worlds... 1, 2, 3
- Swan C of Britain Challenge
- Swan 42... 1st
- 2011 Race 2011**
- Class C... 1st
- 2011 Race 2011**
- IRC Super 0... 1st
- 2011 Race 2011**
- IRC A... 1, 2
- IRC B... 1st
- IRC D... 1st
- J/120... 1st
- IRC B... 1st
- 2011 Race 2011**
- PHRF B... 1, 2, 3
- PHRF C... 1, 2, 3
- PHRF D... 1, 2, 3
- PHRF E... 1, 3
- PHRF F... 1, 2
- NFS... 1, 2
- Class 0... 1, 3
- Class 2... 1st
- Class 3... 1, 2
- Class 4... 1, 2
- Class 5... 1st
- Class 6... 1, 2, 3
- SJ24... 1, 2, 3

## PHRF Full Regatta

- Over 124... 2, 3
- Under 125... 1, 3
- M24x... 1st
- Cal 20... 1, 2, 3
- 2011 Race 2011**
- PHRF A... 1, 2
- M24x... 1st
- Cal 20... 1, 2, 3
- PHRF B... 1, 2, 3
- 2011 Race 2011**
- Overall... 1st
- Beneteau 36.7... 1st
- Beneteau 40.7... 1, 2
- GL 36... 1, 3
- GL 70... 1, 2
- Level 35... 1, 3
- J/111... 1st
- PHRF 1... 1, 3
- PHRF 2... 1st
- PHRF 3... 1st
- Long Distance Class... 1, 3
- 2011 Race 2011**
- Overall & IRC Class 1... 1st
- 2011 Race 2011**
- IRC A... 1st
- Melges 24 Nationals... 1, 2, 3
- Melges 32 Worlds... 1, 2, 3
- Swan C of Britain Challenge
- Swan 42... 1st
- 2011 Race 2011**
- Class C... 1st
- 2011 Race 2011**
- IRC Super 0... 1st
- 2011 Race 2011**
- IRC A... 1, 2
- IRC B... 1st
- IRC D... 1st
- J/120... 1st
- IRC B... 1st
- 2011 Race 2011**
- PHRF B... 1, 2, 3
- PHRF C... 1, 2, 3
- PHRF D... 1, 2, 3
- PHRF E... 1, 3
- PHRF F... 1, 2
- NFS... 1, 2
- Class 0... 1, 3
- Class 2... 1st
- Class 3... 1, 2
- Class 4... 1, 2
- Class 5... 1st
- Class 6... 1, 2, 3
- SJ24... 1, 2, 3

## PHRF Full Regatta

- Over 124... 2, 3
- Under 125... 1, 3
- M24x... 1st
- Cal 20... 1, 2, 3
- 2011 Race 2011**
- PHRF A... 1, 2
- M24x... 1st
- Cal 20... 1, 2, 3
- PHRF B... 1, 2, 3
- 2011 Race 2011**
- Overall... 1st
- Beneteau 36.7... 1st
- Beneteau 40.7... 1, 2
- GL 36... 1, 3
- GL 70... 1, 2
- Level 35... 1, 3
- J/111... 1st
- PHRF 1... 1, 3
- PHRF 2... 1st
- PHRF 3... 1st
- Long Distance Class... 1, 3
- 2011 Race 2011**
- Overall & IRC Class 1... 1st
- 2011 Race 2011**
- IRC A... 1st
- Melges 24 Nationals... 1, 2, 3
- Melges 32 Worlds... 1, 2, 3
- Swan C of Britain Challenge
- Swan 42... 1st
- 2011 Race 2011**
- Class C... 1st
- 2011 Race 2011**
- IRC Super 0... 1st
- 2011 Race 2011**
- IRC A... 1, 2
- IRC B... 1st
- IRC D... 1st
- J/120... 1st
- IRC B... 1st
- 2011 Race 2011**
- PHRF B... 1, 2, 3
- PHRF C... 1, 2, 3
- PHRF D... 1, 2, 3
- PHRF E... 1, 3
- PHRF F... 1, 2
- NFS... 1, 2
- Class 0... 1, 3
- Class 2... 1st
- Class 3... 1, 2
- Class 4... 1, 2
- Class 5... 1st
- Class 6... 1, 2, 3
- SJ24... 1, 2, 3

## PHRF Full Regatta

- Over 124... 2, 3
- Under 125... 1, 3
- M24x... 1st
- Cal 20... 1, 2, 3
- 2011 Race 2011**
- PHRF A... 1, 2
- M24x... 1st
- Cal 20... 1, 2, 3
- PHRF B... 1, 2, 3
- 2011 Race 2011**
- Overall... 1st
- Beneteau 36.7... 1st
- Beneteau 40.7... 1, 2
- GL 36... 1, 3
- GL 70... 1, 2
- Level 35... 1, 3
- J/111... 1st
- PHRF 1... 1, 3
- PHRF 2... 1st
- PHRF 3... 1st
- Long Distance Class... 1, 3
- 2011 Race 2011**
- Overall & IRC Class 1... 1st
- 2011 Race 2011**
- IRC A... 1st
- Melges 24 Nationals... 1, 2, 3
- Melges 32 Worlds... 1, 2, 3
- Swan C of Britain Challenge
- Swan 42... 1st
- 2011 Race 2011**
- Class C... 1st
- 2011 Race 2011**
- IRC Super 0... 1st
- 2011 Race 2011**
- IRC A... 1, 2
- IRC B... 1st
- IRC D... 1st
- J/120... 1st
- IRC B... 1st
- 2011 Race 2011**
- PHRF B... 1, 2, 3
- PHRF C... 1, 2, 3
- PHRF D... 1, 2, 3
- PHRF E... 1, 3
- PHRF F... 1, 2
- NFS... 1, 2
- Class 0... 1, 3
- Class 2... 1st
- Class 3... 1, 2
- Class 4... 1, 2
- Class 5... 1st
- Class 6... 1, 2, 3
- SJ24... 1, 2, 3

# When performance counts, the choice is clear.



The victory list above represents a fraction of the racing success North Sails customers enjoyed in 2011. To show our appreciation, we are offering a *FREE North Regatta Cap* to every North customer who finished 1st, 2nd or 3rd in a North American regatta in 2011. To register for your cap, log onto [www.northsails.com](http://www.northsails.com), then complete the online registration form. *One cap per customer. Offer expires April 1, 2012.*



FREE!

Better by Design

- Sausalito 415-339-3000
- Channel Islands 805-984-8100
- Marina Del Rey 310-827-8888
- Long Beach 562-795-5488
- Costa Mesa - Sail Care 949-645-4660
- San Diego 619-224-2424
- [www.northsails.com](http://www.northsails.com)

Max Ranchi photo



ABOVE: William Douglass and crew power *Goombay Smash* to victory in the Melges 32 World Championships in Palma de Mallorca, Spain. *Goombay Smash* carried North 3DI upwind sails and V-Series downwind sails. North-equipped M32s also finished 2, 4, 5, 6, 7, 8, 9, 10 at the event.

## WHY US?

When you're halfway to the Farallones or halfway across the ocean, it's good to know that your dodger was made by someone who's been there.



All sewing in Tenara thread.

- Classic dodgers and biminis
- Drop-top folding dodgers
- Custom canvas for sailboats

560 W. Cutting Blvd., #2  
Richmond, CA 94804  
Inside the KKMI boatyard

**(510) 234-4400**

Quality  
Yacht  
Canvas

## LETTERS

uses, starting with soaking salty foul weather gear, aching feet, questionable fruit and vegetables, laundry, or anything else you can think of when the sea state would not be conducive to the use of a bucket or the galley sink. When it's all done, a flick of the switch gets rid of the water.

A bathtub is definitely a luxurious touch by liveaboard cruising standards, but it is one of those features of the boat that helps keep the Admiral happy. And when the Admiral is happy . . . you know the rest.

By the way, *Moonshadow* remains for sale in Jacksonville, Florida. She's done one very long lap around the planet and is ready to go again. If she doesn't sell by April, we plan to cruise up the East Coast for the summer.

George Backhus & Merima Dzaferi  
*Moonshadow*, Deerfoot 2-62  
Ex-Sausalito / Auckland, N.Z.

### ↑↓ BUT NOT IN SEAS OVER FIVE FEET

Ever had sex in a sailboat sitz tub while doing the Baja Bash? I recommend it. The rougher the better. I'm talking about the sea state, not necessarily the sex.

Anonymous  
Stockton Sailing Club

### ↑↓ MOVING TO ANOTHER PART OF THE HEAD . . .

I recently read an article in another sailing magazine about composting toilets and the Airhead Composting Toilet in particular. On the manufacturer's website they claim no odor, no holding tank, no clogging, fewer breakdowns, less maintenance, easy installation, low cost, good on the environment, no hoses and all that stuff.

It almost sounds too good to be true, so I'd like to hear from someone in the area who has used or still uses a composting toilet. Do they work as well as is claimed, and particularly, are they really virtually odorless?

Gordo Klenk  
*Perigee*, Beneteau 43  
Truckee / Emeryville

Gordo — We'll be as interested as you in the responses.

### ↑↓ WHY NOT REDUCTIO AD ABSURDUM?

In the November *Latitude* there was a reference to philosopher Ludwig Wittgenstein by the publisher in an editorial response, as well as references to quantum mechanics by *Max Ebb* in his column. I don't see that kind of stuff in the downstream sailing rags.

I have always wanted to name a boat *Private Language*, but I've only done so in a parallel universe.

Tony Johnson  
*Whisper*, Catalina 22  
San Francisco

Tony — We're not trying to be 'higher brow than thou', but we did go to college and assume that most of our readers did also. And when we get a letter like the next one, we just can't help ourselves.

To set the record straight, we had to refer to the Stanford Encyclopedia of Philosophy to fully appreciate your *Private Language* joke. Pretty funny.

### ↑↓ FROM A HUFFY TO A FOLKBOAT

I've been following the *Latitude Classifieds* for several years and am curious if you have a way of telling whether boats that no longer appear in ads have actually sold or if

The Navy specifies the use of Dr. LED's lights. Shouldn't you?

Spreader Light

CREE #1US LED Bulbs

LED Search Light

SMD LED Bulbs

Underwater Lights

Recessed Lights

2nm Nav Light LED Bulbs

Dome Lights

Under-Cabinet Lights

Chart Light

[www.DoctorLED.com](http://www.DoctorLED.com)

Port Supply

West Marine  
We make boating more fun!



Management  
Consulting  
Development

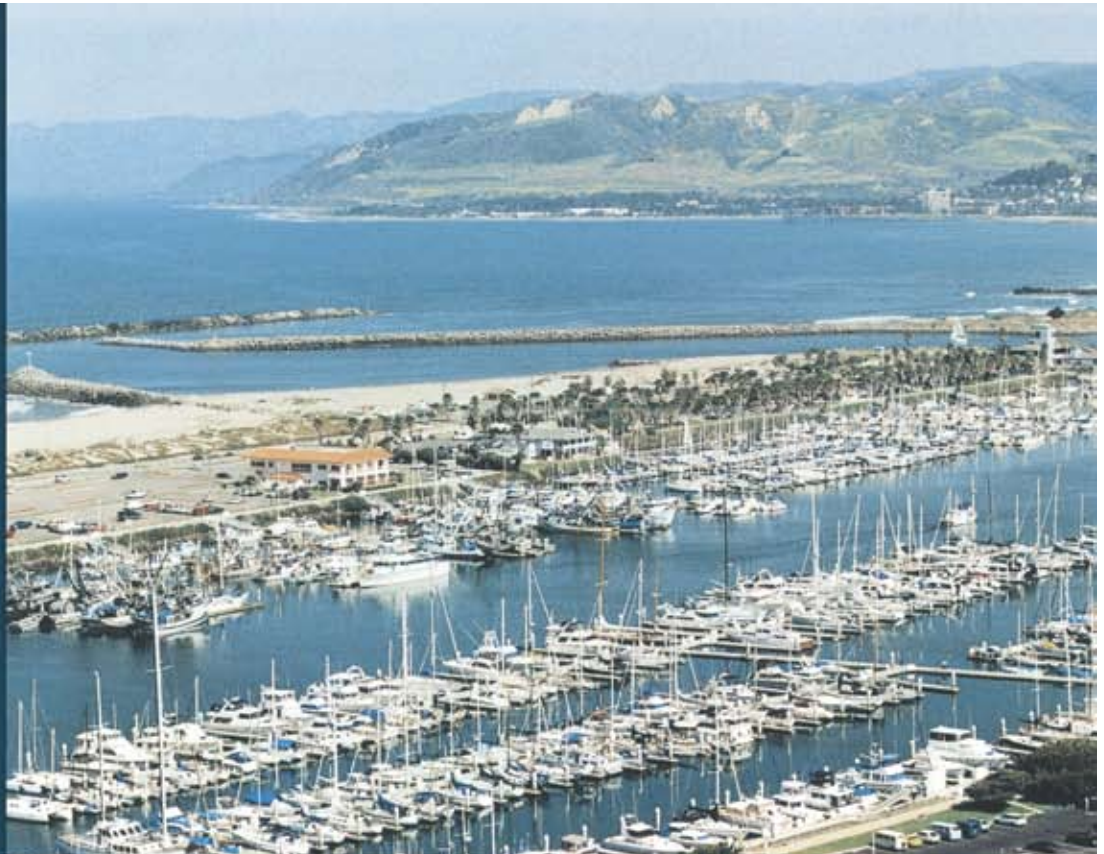

## Almar Marinas

Join one Almar Marina and you have reciprocal privileges at any of Almar's 17 locations from San Francisco to San Diego and out to Hawaii. Programs included in your slips fees:\*Boat Handling Classes\*Navigation Courses\*Electrical Courses\*Anchor Outs\*Seminars on Local Destinations.



EST. 1973

[almar.com](http://almar.com)

San Diego\* Cabrillo Isle Marina\* Marina del Rey\* Marina del Rey Marina\* Channel Islands Harbor\* Bahia Marina\* Anacapa Isle Marina\* Peninsula Marina\* Westport Marina\* Ventura Harbor\* Ventura Isle Marina\* San Francisco Bay\* Treasure Isle Marina\* Jack London Square\* Jack London Square Marina\* Oakland\* NEast Basin Marina\* NWest Basin Marina\* Embarcadero Marina\* Union Point Marina\* Alameda\* Ballena Isle Marina\* Martinez\* Martinez Marina\* CA Delta\* RiverPoint Landing\* Honolulu\* Kewalo Basin Harbor\* Oahu\* Iroquois Marina\*

# GET YOUR BOAT READY FOR SPRING...

**SAVE 10%**  
on Parts & Service  
THROUGH  
2/29/2012

**AND SAVE SOME \$\$!**



AUTHORIZED DEALER FOR:



FULL SHOP • FACTORY TRAINED • MOBILE SERVICE

**Drake Marine**

The Peninsula's #1 Marine Service Center

671 Marina Blvd., South San Francisco, CA 94080

info@drakemarine.com

(650) 588-3015 • www.drakemarine.com

## LETTERS

their owners have simply taken them off the market for a lack of buyers. This info might help me in future negotiations for a boat.

I might add that I'm currently in Penang, Malaysia. While dock haunting one afternoon, I met Allen and Margaret, a couple who are doing a circumnavigation aboard their junk-rigged schooner *Zebedee*. They were delightful, and generous with their advice and stories of their adventures. This often seems to be the case when I walk the dock and meet cruising sailors.

I've been traveling for seven years, mostly in Asia, although I returned to the U.S. in '09 to complete a seven-month bicycle ride through the States that covered 13,700 miles and crossed into 32 states. I had a BOB trailer for my camping equipment, and had an amazing time.

But I must say, I'm a big fan of taking off on a sailing adventure, and am researching boats, mostly styles that are knockoffs of the Folkboat, such as the Pearson Triton. My funds are modest and I want to keep things small and simple. Like the Pardeys. And because my funds are modest, I want to get the best deal on a boat that I can.

Allen Sneidmiller  
Chico / Penang, Malaysia

*Allen — We're intrigued by your email address, which starts with 'heraclitus'. Heraclitus was, of course, the pre-Socratic philosopher from Ephesus — now Turkey — best known for his contempt of mankind and his belief in constant change. "You can't step in the same river twice" is his best known dictum, and his belief that "up is the same as down" seems to have a delightful whiff of Buddhism.*

*Enough of that. We can't give you any exact figures, but boats are no different than houses in the sense that when the market is soft — as it certainly has been for some time — inventory frequently gets taken off the market after not selling for a period of time. For instance, we know of a number of cruisers who have their boats up for sale because they want to move up to larger boats or switch from monohulls to more expensive catamarans. But if they can't sell the boat they already have, they can't afford the new boat. So when the November-to-May cruising season in Mexico rolled around, they took their boats off the market and took off for tropical Mexico. For a slight variation on this theme, see the letter above from circumnavigator George Backhus.*

*But take our word for it, there has never been a better time to get a bargain on a boat, no matter what price range you're in. The struggling — but maybe slightly improving — economy in the U.S., the debt woes in Europe, the aging population — everything favors great deals for boat buyers.*

*Without any disrespect, it sounds as if you know about as much about sailboats as we do about bicycles. We base this on your comment that a Triton is a "knockoff" of a Folkboat. That's not really true, as about all they have in common is a single hull, a single mast, a rudder, and a full keel. Until you've been into sailing for a period of time, it's hard to appreciate the seemingly subtle but nonetheless substantial differences in boats.*

*Assuming you want to cross oceans on a budget, the biggest decision you'll probably need to make is where you want to be on the speed/comfort spectrum of boats. If simplicity is your thing — as it is ours — you might be interested in a boat that is more on the performance side. No matter if you opt for more speed or more comfort, we think you're going to have a blast exploring the world by boat, and at a surprisingly low cost.*

*Oh, and to answer your original question: no, there's no way for us to track which Classy boats sold or were merely*

**"Heck, if I were dumb enough to own three boats, there's no doubt she'd be fitted with a VariProfile as well!"**

*Peter Stoops*

OPTIMIZED FOR ENGINES UP TO 140 HP

*My Swan 36 is an old boat (40 years), but she's still meant to be a relatively fast one. I looked at all the available props and settled on the VariProfile. It was feathering vs. folding, it had excellent drag and thrust characteristics, it was easily adjustable underwater, and the sales/technical/customer service assistance I received — and continue to receive — at all phases of the purchase was top-notch. In fact, I liked the VariProfile well enough to buy it again — this time for our other boat, an old Swan 40. That prop has taken her across the Atlantic and the Mediterranean quickly and with no problems.*



**VARIPROFILE**  
Feathering Propeller

207-354-7064 | info@varipropusa.com | www.varipropusa.com

Mention code L38 for two free anodes with a propeller purchase!



**THE LARGEST ALL-SAIL BOAT SHOW  
ON THE WEST COAST!**

# *Strictly Sail Pacific*

**April 12-15, 2012**  
Jack London Square • Oakland, CA



**SEE** – New Boats · Cool Gear · The Latest Technology

**DISCOVER** – New Horizons · New Skills · Family Adventure

**LEARN** – To Tie a Knot · To Navigate the Seven Seas

**MEET** – Sailing Experts · Industry Professionals · Authors

**ENJOY** – On-the-Water Activities · Parties · Live Music



Visit [www.StrictlySailPacific.com](http://www.StrictlySailPacific.com) for tickets and show details

## Defender 16<sup>th</sup> Annual Warehouse Sale

★ March 29 - April 1, 2012 ★  
Lowest Prices of the Year!

# LEWMAR®



Most orders placed by 4pm ship the same day!

### Mainsheet Traveler Kits

**Size 0 For boats up to 28' - 2:1 Purchase. Kit contains:**

(1) Mainsheet Car, (1) 1.2m Sliding Bolt Track (2) End Stops, (2) Small Composite Cleat (1) Size 1 Dead Eye, (2) Small Cam Fairleads  
Item 602181 • List \$299.99

ONLY \$200

**Size 1 For boats up to 36' - 4:1 Purchase. Kit contains:**

(1) Mainsheet Car Shackle and (2) Double Control Line Sheaves, Cleats and Becket, (2) End Stops with Double Control Line Sheaves, (1) 1.5m Sliding Bolt Track  
Item 615000 • List \$587.00

ONLY \$385

**Size 2 For boats up to 48' - 4:1 Purchase. Kit contains:**

(1) Mainsheet Car, Shackle, (2) Double Control Line Sheaves, Cleats and Becket, (2) End Stops with Double Control Line Sheaves, (1) 1.8m Sliding Bolt Track  
Item 601647 • List \$815.00

ONLY \$535

# Defender®

www.defender.com • 800-628-8225

THE BRANDS YOU WANT AND TRUST IN STOCK FOR LESS

FREE CATALOG!

## HIRSCHFELD YACHT

Marine Repair and Installation Specialists  
Full Service Shop with Dockside Access

- Electrical
- Engines
- Outdrives
- Generators
- Inboard/Outboards
- Propellers
- Controls
- Installation
- Transmissions

## BETA MARINE WEST

Engineered to be serviced easily!

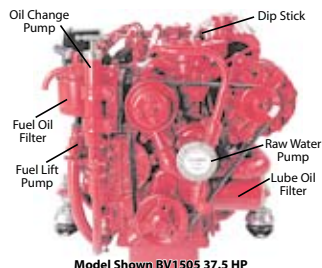

Model Shown BV150S 37.5 HP



Dealer for Suzuki Outboards

400 Harbor Drive, Sausalito, CA 94965

(415) 332-3507

www.betamarinewest.com  
www.hirschfeldyacht.com

## LETTERS

pulled from the market.

### ↑↓ CARIBBEAN TIPS

A friend of mine recently crossed the Atlantic and is in Grenada. He'll be headed north shortly to St. Martin and Antigua. What airports in that region are the least expensive to fly into? He'll be in the Caribbean all season.

Dave Benjamin  
Island Planet Sails

Dave — Ticket prices to the Caribbean vary wildly depending on the airline, the month, the day of the week and loads. You can fly to some of the big islands directly from Miami or New York, or else you have to fly into the big Caribbean hubs of San Juan



WEBB LOGG

or St. Martin and then catch puddle jumpers from there. We'd look around on kayak.com or similar websites to see what you can come up with.

If you're a thrill-seeker, we'd recommend flying into St. Martin. This is a real photo.

or St. Martin and then catch puddle jumpers from there. We'd look around on kayak.com or similar websites to see what you can come up with.

If you have a couple of weeks, we'd start in Martinique or Antigua, then work toward St. Martin or the British Virgins rather than vice versa. That's assuming you're of the school of thought that believes it's more fun to reach and run than beat into the trades.

We know that you did a season cruising in Mexico, so we're going to warn you to be prepared for: 1) Severe sticker shock, as the prices of everything — especially food — are astonishingly higher, and 2) island populations that are generally much less friendly than the people of Mexico. On the other hand, you're going to love the clear water and consistent sailing breezes.

### ↑↓ THOUGHTS ON SHOREPOWER CORDS

Why is it that almost every boat in every marina is plugged into shorepower? What's the point in having miles of heavy electrical cord servicing phantom loads on boats — boats which, in many cases, are seldom visited? Sure, you need the shorepower if your boat leaks and will sink once the bilge



TIM SELL

pump goes off and the battery runs out of juice. And yes, you need to keep your boat plugged in if you've got frozen bait in the freezer.

But aren't boats supposed to represent freedom and independence?

Winter is prime time for shorepower cords to burn up from overloading.

Can you imagine a Viking saying, "Hey Erik, get the shorepower unplugged, we gotta go raid the English." Or on the *Deadliest Catch*: "Hans, get the shorepower cord, we gotta go catch some king crab."

For the cost of a shorepower cord and an electrician to fix the sockets that often go bad, you can buy a solar panel that will keep making power for the next 15+ years. And can you imagine the awful working conditions in some Third World country where factory workers have to labor to bring us a



# Share the Sport You Love

Dear Sailor,

Have you ever tried to describe why you love sailing to a non-sailor? To convey the joy and exhilaration of moving across the water powered only by the wind? Of being completely in the moment, balanced between wind, waves and current?

By telling the story of Bay sailing, you share our world of adventure, freedom, and self-discovery with a future generation of sailors.

Help share our mutual passion for sailing by joining me and SailSFBay in our support of ac-



claimed filmmaker Ron Blatman's upcoming project, *Sailing the Bay*. Blatman's highly-rated PBS documentary 'Saving the Bay' won four regional Emmy Awards, and very effectively spread awareness about the rich history and sustained health of our San Francisco Bay. The same magic Blatman and his team conjured to create 'Saving the Bay' will now produce 'Sailing the Bay', a one-hour film that will debut on KQED just ahead of the America's Cup in Spring 2013.

Our immediate goal is to raise \$50,000 in seed money for the project. All we need is for sailing enthusiasts like you to show support with a tax-deductible donation of any size: \$10, \$25, \$50 or more. It's important to show potential sponsors that the sailing community is behind this project and dedicated to nurturing our sport.

I invite you to join me, and the sailing community to which you belong, in sharing the story of Bay sailing with a wide audience. Please make a tax-deductible gift that will produce huge returns for the next generation of sailors.

Sincerely,



www.SailSFBay.org

**Donate Today!**

[www.sailingthebay.com](http://www.sailingthebay.com)

# THIS YACHT MAINTAINED BY:

## Stem To Stern

FOR ALL CONCERNS, PLEASE CALL:  
**(510) 681-3831**

Responsibilities of the

### In-port Captain

Yacht Security • Cruise Preparation  
Maintenance Scheduling • Delivery Services

- Hull Cleaning
- Washdowns
- Interior Cleaning
- Detailing
- Brightwork
- Mechanical Service and Repair
- Pump-Out
- Boat Yard Set-up and Management

Check out our website for a list of all our services at

**www.StemtoSternSF.com**

or call (510) 681-3831

**We Take the Work Out of Owning a Boat**

## LETTERS

50-ft shorepower cord that costs \$100?

In my opinion, having shorepower to run all kinds of consumer goods is what's wrong with boating today. Nothing says 'I'm not staying here for very long' like an array of solar panels. And if you really want your neighbors to be more than happy to help you get your boat ready for a cruise, you might install a wind generator. They really howl.

Tim Sell

Lucky Star, Brent Swain 36  
Sausalito / Honolulu

Tim — Like you, simple is our personal preference. That's why we don't have blenders, coffee makers, ice makers, bread machines, televisions or toasters — let alone a microwave oven — aboard Profligate. And which is why Doña de Mallorca, who is in charge of domestic matters aboard Profligate, often unplugs or turns off the shorepower when we leave the boat for even a few days. Yes, we have solar panels to keep the house batteries topped off. But sinking is not a concern because Profligate has five separate bilges in each hull.

But if we're not mistaken, the number one reason for having shorepower connected is to keep the bilge pump running if the boat begins to leak. Most solar panel arrays in Northern California are not going to be able to keep up with the electrical needs of a bilge pump that's going non-stop. Juice is also used to keep a humidifier and/or fan on in the winter in order to prevent mold. To our thinking, those two reasons are enough to justify hooking up.

### ↑↓ HOW ABOUT AN A-CUP RACE TO THE FARALLONES?

You asked for suggestions about America's Cup courses. Well, I'm asking *Latitude* to please rally the sailing community, the media, and America's Cup officials for a Farallon Islands leg. It would lend a lot of drama — especially during a reinforced tradewind — and would truly challenge both the men and the machines. The boats would be followed by helicopters that would broadcast the drama. And the course would be sailed no matter how strong the winds or how big the seas.

Heavy weather sailing for the Cup would be spectacular!

Philip Hoffman  
Bolinas

Philip — Sounds like lots of fun! Alas, the most extreme racing boats are designed and built to meet conditions they are expected to race in. As Buddy Melges once famously noted, an ideally designed and built America's Cup boat would fall apart the second she crossed the finish line of the last race. If she didn't, she would have been overbuilt and therefore slower than she could have been.

To ask America's Cup sailors to sail a leg out to the Farallones and back no matter how strong the winds would be like asking Formula One car racers to drive the Baja 1000. Not that smart. If, on the other hand, the weather guys could promise less than 15 knots of wind and flat water, we'd be totally in favor of one such race. It sure wouldn't take long, would it?

Not to be snarky, but Northern California doesn't have tradewinds, let alone reinforced tradewinds. Bay and Delta winds come from the Central Valley heating up during summer afternoons, which causes the cold ocean air to be sucked in through the narrow gaps toward the Valley in order to equalize the pressure. The hotter the Central Valley, the stronger the winds — unless there is a big high pressure area over the entire area. San Francisco Bay winds are generally lighter in the winter because there isn't a very big difference in temperature



Check  
out our  
"Must-See"  
website!!

**The Iverson's Dodger is now  
available in the Bay Area!**

Dodgers • Bimini Tops • Enclosures

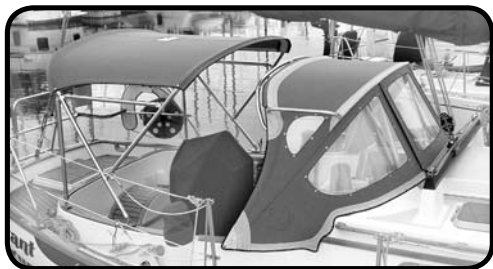

206-849-2274

**iversonsdesign.com**



PERFORMANCE ■ COMFORT ■ STYLE ■ INNOVATION ■ VERSATILITY

# LE PARD CATAMARANS

THE #1 SELLING CATAMARAN BRAND IN  
NORTH AMERICA!

Come See us at the

Strictly Sail Pacific Boat Show  
Oakland, California, April 12- 15, 2012  
Tour the Popular Leopard 46

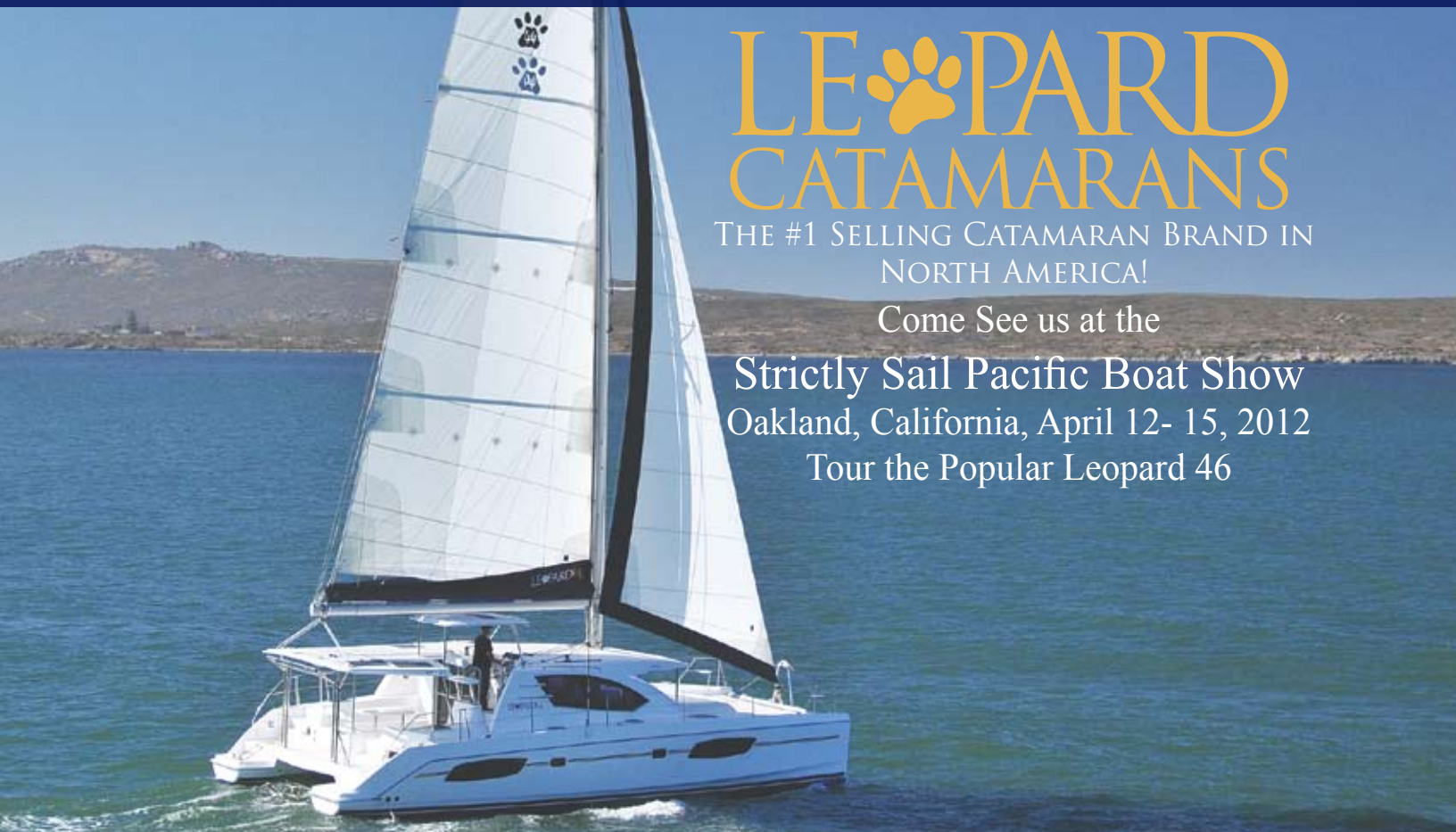

# LE PARD CATAMARANS

Leopard Catamarans consistently delivers award-winning yachts (Boat of the Year 2005, 2007, 2010, 2012), making us the **#1 Selling Brand of Catamarans in North America**. With the launch of the exciting new Leopard 44, we're focused on our commitment to bringing you the best catamarans in the world. Visit us online for boat show schedule, images, virtual tours, and additional information.

[www.leopardcatamarans.com](http://www.leopardcatamarans.com) | 1-800-672-1327 |



Scan to view  
our virtual  
tour





# McGinnis Insurance

Since 1972

## Agreed Value Yacht & Boat Policies

### Offshore, Coastal, Inland, Liveboards & Floating Homes



**Alameda Boat Fest March 1-4**

Call us at: **800-486-4008**

meginnsins@aol.com ⚓ License #0570469

## SAVE UP TO \$2,500 WITH YOUR COSTCO CARD



### New Cash Savings for Costco Members

Call or stop by our showroom!

Costco Member Program has been renewed for 2012.

**BOSTON**  
**WHALER**

**Outboard Motor Shop**

**(800) 726-2848**  
**(510) 533-9290**

1926-2012  
Your Bay Area Dealer  
For 86 Years

**333 Kennedy Street  
Oakland, CA 94606**

[www.outboardmotorshop.com](http://www.outboardmotorshop.com)

All Prices INCLUDE freight & prep, plus tax & license only.

3003

## LETTERS

*between the Central Valley and the ocean.*

### ⚡ AMERICA'S CUP COURSES

I'm a bit of a dated foredeck man, so I'm not the best one to ask about the best possible America's Cup courses, but these are my suggestions:

**Long Course:** Start in front of Golden Gate YC; upwind to Blackie; across to a buoy off the Spinnaker Restaurant in Sausalito; down Raccoon Strait close to the Tiburon shore to a mark off the south side of Angel Island; back up The Slot from Angel Island to Alcatraz; then upwind home to the Golden Gate YC finish. There would be plenty of places that would offer lots of room for spectating. Yes, I know there would be lots of wind in some places and not so much in other places, but I think that would make things more interesting for all.

**Short Course:** I don't like the idea of a short course. Screw short courses!

Oops, the wife just went by with no clothes on. Gotta go.

Pete Groves

*Fast Water, Tayana 52  
Roche Harbor, WA*

### ⚡ HOPING FOR A FRIENDLIER STAFF FOR THE AC

I'd like to chime in on the January issue letter from Karen Sullivan complaining about the attitude the security people at the America's Cup World Series event in San Diego had toward non-VIP spectators.

My wife Jennifer and I watched the races on the water from a friend's boat, and they were nothing short of fantastic! When I landed, however, I have to agree with Karen, as we got the same attitude from the security forces. But it's San Diego, you know. While I hate to stereotype an entire city, law enforcement in San Diego seems to have a bit of a militaristic mindset. After all, who can forget the famous Harbor Police 'panty raid' and subsequent 'panty protest' during and after the first Ha-Ha?

By the way, Jennifer and I just got back from the British Virgins where we did a week charter with John and Lynn Ringseis aboard the publisher's Moorings/Leopard 45 cat 'ti Profligate'. We had a blast. And despite the fixed three-blade props, we really had her moving on a 25-knot day from Jost to Anegada!

Dave Fiorito

*Shenanigans, C&C 36  
Berkeley*

*Dave — We're glad you enjoyed the America's Cup action in San Diego, and hope the organizers will be able to put a friendlier face on security when the World Series resumes. After all,*



LATITUDE / RICHARD

*'ti is nothing special, just your average ex-Moorings 45 cat in very decent shape. What's unusual is the 'bang for the buck'.*

*Sausalito-made salon cushions down as luggage, as it would have allowed you to christen them with your bottoms. Now we get to do it.*

*How is this for an unabashed plug? The folks at BVI Yacht*



*Come Visit Us Today!*

# SOUTH BEACH SAILING CENTER

at the  
beautifully renovated Pier 40 in San Francisco

## South Beach Riggers

**DO IT ONCE.  
DO IT RIGHT.  
PERIOD.**

**415.331.3400**

[www.SouthBeachRiggers.com](http://www.SouthBeachRiggers.com)

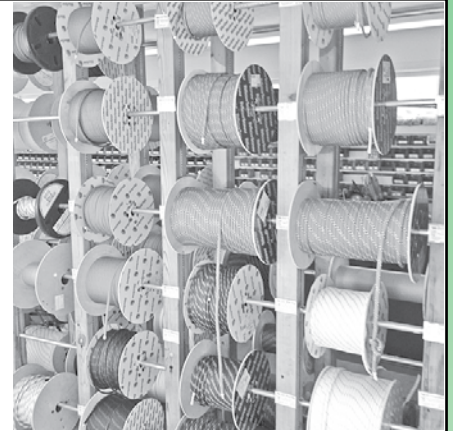

- Mast • Rigging
- Fabrication
- Hydraulics
- Insurance Work
- More...

**20+ years  
specializing in  
nautical interiors.**

- Our showroom has the most extensive collection of marine-oriented fabrics anywhere!
- Award-winning yacht upholstery and design
- Creative approach
- Results ideal for all Yachters



*Liz Diaz,  
Master Fabric  
Craftsman*

**NORTH  
BEACH  
MARINE  
CANVAS**

**nbmc@earthlink.net  
www.northbeachmarinecanvas.com  
Pier 40, The Embarcadero  
South Beach Harbor, San Francisco**

**415.543.1887**

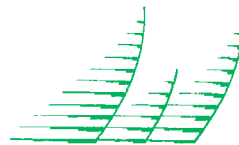

## Westwind

Washing, Waxing, Varnishing  
and Interior Cleaning



*"I must tell you that it is  
this kind of integrity that  
brings repeat business.  
You have a rare work  
ethic for a company that  
is in the marine industry.  
Keep it up!"*

- Alexi Stavropoulos

**Winter project? 10% DISCOUNT  
on Interior Woodwork & Interior Cleaning**

*'Paralos'  
Lagoon 38*



*Serving the entire Bay Area for more than 25 years.*



[westwinddetailing@sonic.net](mailto:westwinddetailing@sonic.net)  
[www.boatdetailing.com](http://www.boatdetailing.com)



Adjacent to South Beach Harbor and AT&T Park • Close to dozens of fantastic restaurants and shops



# BRING BACK THE GOOD LOOKS OF YOUR SAIL

Vacu Wash® is the leading washing technique for laminated and woven sails, displaying extraordinary results where other don't. Go to our website and see the many 'before and after' examples and see how easy it is to ship your sails to our facilities in tax-free New Hampshire. Good looks DO matter...



[WWW.VACUWASH.COM](http://WWW.VACUWASH.COM)

**Sailmaking Support Systems**  
588 Portsmouth Ave., Greenland  
NH 03840 (Tax-free), USA  
Tel.: (603) 373 6836. Fax: (603) 431 6335  
order-usa@vacuwash.com

## NAPA VALLEY MARINA = SERVICE

CALL  
US  
TODAY!



- Engine repair – diesel and gas
- Shaft Alignment
- Outdrive repair
- Bottom Jobs –
- Gel Coat Repair
- **AWLGRIP** Paints

*California's Largest Dry Storage Facility*

## NAPA VALLEY MARINA

1200 Milton Road • Napa, CA 94559  
(707) 252-8011 • Fax (707) 252-0851  
[www.napavalleymarina.com](http://www.napavalleymarina.com)

Marina • Boatyard • Chandlery • Brokerage

Dealers for  
**YANMAR**

**Interlux**  
yachtpaint.com

Distributors for *Brownell*  
Boat Stands

## LETTERS

Charters book 'ti Profligate at perhaps the lowest price of any four-cabin, heads ensuite, 45-ft cat in the Caribbean. And she's in fine shape. Maybe that's why she's not available again until June 2, but it's not too early to book her for next winter. 'ti Profligate is a strictly 'big bang for the buck' cat, so while she came directly out of The Moorings program a few years back, she doesn't have air conditioning, AC for hair dryers or coffee makers, or electric toilets, as do some of the more modern Moorings charter cats.

### ↑↓ **LATITUDE IS ON FIRE!**

I brought my new Kindle Fire down to Puerto Vallarta with me so I could stay connected. I'm currently sitting on a balcony overlooking Banderas Bay catching up on the 'Lectronic postings. 'Lectronic looks fantastic on the Fire.



DOUG VAUGHAN

Doug Vaughan  
Odyssey, Jeanneau 37  
Oakland UC

'Lectronic looks great on the Kindle Fire.

Doug — We love it! You can also get the eBook version of Latitude on your Kindle. Just download the file(s) to your computer, then transfer them to the Kindle via the USB cord. Here's a link to a complete set of instructions and a video: [www.amazon.com/gp/help/customer/display.html?nodeId=200728710#usb](http://www.amazon.com/gp/help/customer/display.html?nodeId=200728710#usb).

### ↑↓ **THERE'S JUST NO COMPARISON TO OR IN LATITUDE**

As Latitude is the best and most informative sailing publication, what would you guys think about having a boat test section each month, as they do in motorcycle and car magazines? Comparing the sailing, quality, performance, quirks, and availability of three or four new or used boats — i.e. a Catalina 36 against an S2 36 or Saber 36 or Islander 36. I think this would give Joe Public an idea what might be the best product or application for them.

Don Little  
Syzygy, Santana 20  
Folsom Lake

Dan — We don't know if Latitude is the best sailing magazine, but our staff busts our bottoms each month to try to provide readers with the most information we can. So on behalf of them, thank you for the kind words.

It's always been our opinion that you can't test or compare boats as you can cars or motorcycles. It's not a problem to quickly find the variety of environments motorcycles will operate in. Give us a car in Marin County for three hours, and we can give you a decent assessment of how it will do on freeways, in traffic, up hills, on curvy roads, fleeing the police, and in most other conditions except snow.

Because sailboats operate in a much greater variety of conditions, legitimate testing would take far more time — as in days, if not weeks. Heck, the folks from Adventure Cat once told us it took them a year to understand how to sail their cat. After launching Profligate, we understood what they meant.

In addition, the operator of a sailing vessel is a much greater variable than a driver of a car, so that could throw things way off, too. For example, if you put a good sailor at the helm of a Corsair 31, he or she will quickly have that tri singing. But put a novice or average sailor at the helm of the same tri, and he/she might soon be swimming next to the overturned hulls.



35-55' slips available

# Own a Dock on San Francisco Bay Perfect Location - Great Investment!

EMERY COVE  
YACHT HARBOR

**Come secure a front row seat for the cup races in 2012/13.**

**BUY A SLIP** - Save money and earn equity! Save on your annual rental cost. Enjoy tax savings as a slip owner. Enjoy low maintenance as an investment property. Emery Cove Yacht Harbor is the only marina on the Bay with FEE SIMPLE (not a grounds lease) dockminium ownership. Listings start at \$32,000.

**RENT A SLIP** - 35-60' slips, rates from \$9 to \$10.

**WIRELESS INTERNET** - Free. **MARINA GUARD®** - Ground fault monitoring

Emeryville Yacht Club,  
Mathiesen Marine,  
Michael Wiest Yacht Sales  
& SailTime  
on premises



**CALL FOR A MARKETING PACKAGE • 510-428-0505**  
3300 Powell Street, Emeryville, CA 94608 • [www.emerycove.com](http://www.emerycove.com) • Email: [info@emerycove.com](mailto:info@emerycove.com)

## SEA FROST®

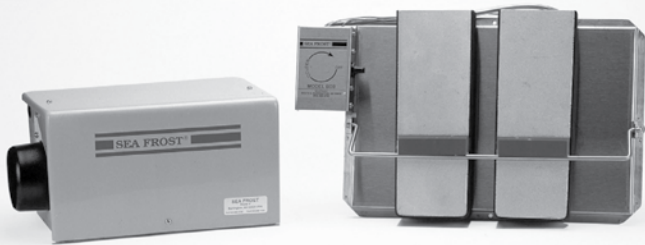

### COOL IT YOURSELF!

Refrigeration has never been easier. Sea Frost's compact and powerful, 12-volt BD refrigeration conversion kit comes pre-charged and ready for owner installation.

**Sea Frost... Quality at an affordable price!**

#### Local Dealers:

Anderson Refrigeration Co. • Alameda, CA  
(510) 521-3111

Poole Refrigeration Service • Alameda, CA  
(510) 523-3495

[www.seafrost.com](http://www.seafrost.com)

## Ultra Connector.

Is your anchor to rode connector reliable?



**Ultra Flip Swivel** is the strongest, most reliable device for connecting anchor rode to your anchor. Don't compromise. Get an Ultra Flip Swivel.



Home of the Ultra Anchor

8700 Warner Ave. Suite #110 Fountain Valley, CA 92708  
[www.ultraanchors.us](http://www.ultraanchors.us) • [sales@quickline.us](mailto:sales@quickline.us) • 714 843-6964

The world's highest quality marine products.

## OXBOW CANVAS AND UPHOLSTERY

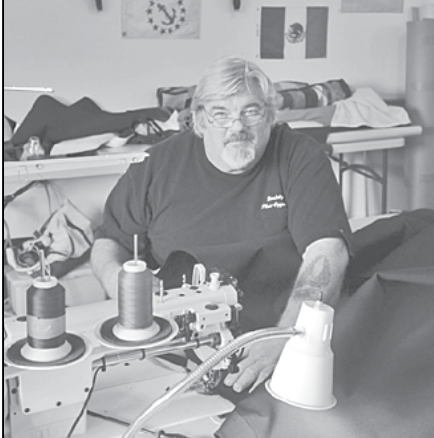

With Over  
50 Years  
in Marine  
Fabric  
Fabrication.

**Not the Largest Shop in the Bay & Delta  
Just the Best!**

Contact them for a consultation.

100 Oxbow Marina Drive  
Isleton, CA 95641

[www.CanvasAndUpholstery.com](http://www.CanvasAndUpholstery.com)

**(209) 327-9870**

## LETTERS

Yachting World has always done the most extensive boat tests and/or comparisons, but we're still not crazy about them, which is why we've never done them. Sorry.

### ↑↓ A WORD FROM THE DESIGNER



LATITUDE / ANDY

'Cat 2 Fold' was an eye-catcher during the last Baja Ha-Ha.

Thanks for the wonderful December *Sightings* on the *Cat 2 Fold* 36 design. While I did the 3D modeling and drafting of plans, Rafi Franke created the innovative concept(s) and design improvements after the plans.

Kurt Hughes  
Seattle, WA

Kurt — Thanks for the heads-up. And thanks again for your 60-ft charter cat design, which was the basis for Profligate. It's been the all-but-perfect cat for us.

### ↑↓ THE COMPLETE HISTORY OF LATITUDE 38

I recently attempted to learn something about the history of *Latitude 38*, but couldn't find anything on your website. It might have been because I had a few beers in me. But I think you've been around long enough that you need to talk about it.

Rob Boyle  
Planet Earth

Rob — We think we've told this story enough, but since the next issue will mark the 35th anniversary of the founding of *Latitude 38*, we guess we can retell it one last time. The idea for *Latitude* came from a dreadful boating magazine in Southern California whose publisher said he worked two days a week in shorts and flip-flops and made \$2,000 a month — a very decent amount of money back then. We made the mental commitment to go ahead with the magazine while watching the Bicentennial fireworks explode over San Francisco while sailing home from the Delta in '76 on our 41-ft *Bounty II* Flying Scud.

The magazine was an ultra-low budget operation from the get-go, funded with \$2,000 — which was all we had to our name. We believe that starting with so little money, along with assiduously avoiding debt, have been two of the keys to long-term success. The original staff consisted of the current publisher, then 29, and Kathleen McCarthy, our then-wife, who sold advertising and quickly became a mainstay of the magazine.

Flying Scud, berthed in Sausalito's Clipper Yacht Harbor, served as our home, office and photo boat. Actual production was done in the middle of the night using The Montclair production facilities in the Montclair District of the Oakland Hills. We drove over the Bay and Golden Gate Bridges countless times at 3 a.m. Immediately after starting the magazine, we were transformed from a happy-go-lucky, carefree — and probably very lazy — person into the workaholic we remain today. We can't believe we still haven't kicked the disease.

The first issue of *Latitude*, 40 pages, appeared in the spring of '77, and featured Bill Lee's revolutionary 67-ft ultralight Merlin. By sheer luck, sailing was mushrooming. In addition to Merlin accelerating the Santa Cruz ultralight revolution, Dave Allen's *Imp* soon took the international racing world by storm, singlehanded sailing exploded, the Pacific Cup was founded, and sailing became more about individuals and less about

## ULTRA SMALL CABIN AND WATER HEATER

### DEPENDABLE COMFORT

Be comfortable all year round with a quiet, reliable Webasto hot water heating system. Can be linked to pre-heat an engine and provide all the hot water you'll need in the galley or for showers.

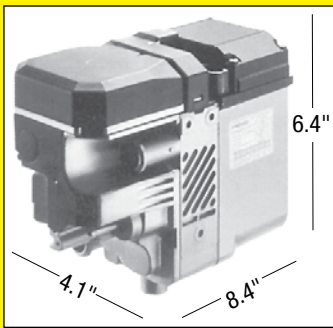

**Webasto**

### CERAMIC IGNITION SYSTEM

- Heat output 17,200 btu/hr (5kw)
- Fuel Consumption .18 gal/hr
- Power Consumption 32 w
- Weight 6.4 lbs

CALL FOR  
MORE  
INFORMATION



**SWEDISH MARINE**

1150 BRICKYARD COVE RD., SUITE B6  
PT. RICHMOND, CA 94801 (510) 234-9566



*We look forward  
to seeing you!*



Imagine yourself in 20 acres of park-like beauty just off  
the San Joaquin River – channel marker 41.  
Imagine your boat at a friendly, clean and relaxing marina.

**THIS IS OWL HARBOR!**

Monthly Berths and Guest Slips available • Yacht Clubs always welcome

**[www.owlharbor.com](http://www.owlharbor.com)**

**(916) 777-6055**

1550 W. Twitchell Island Road ✦ Isleton, CA 95641

SEA SHINE

**Service of the Month**

**INTERIOR CLEANING**

Keep your boat dry and mildew-free with our interior cleaning service. Remember to run a dehumidifier – with the cold temperatures, the boat's interior will stay moist for weeks!

**ADDITIONAL SERVICES**

Interior Cleaning • Detailing • Maintenance  
Polishing • Carpet & Cushion Cleaning

**Fully Insured & Marina Approved**

**Serving the Bay Area Since 1986**

**Call now for a Free Estimate**

**510 428-2522 or 415 457-6300**

**[www.seashine.net](http://www.seashine.net)**

**Antares<sup>44i</sup>**  
THE WORLD'S BEST LIVEABOARD



Glass windshield, complete engine instrumentation, and weather enclosure make the Antares a true all-season catamaran.



613.544.9283

[www.liveantares.com](http://www.liveantares.com)

[info@liveantares.com](mailto:info@liveantares.com)

Toronto

Charleston

Buenos Aires

# Time to Redo Your Non-Skid?



- No haul out – all work done right in your slip
- KiwiGrip Non-Skid System – the finest non-skid on the planet
- 1/3 the cost of a traditional non-skid job

[www.nznonskid.com](http://www.nznonskid.com)  
949-612-2730

## SAUSALITO

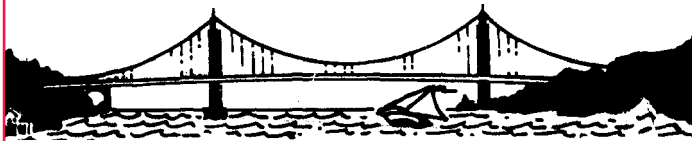

# LIST MARINE INC.

- Full service engine shop
- We service all makes
- Dockside facilities
- Mobile service trucks

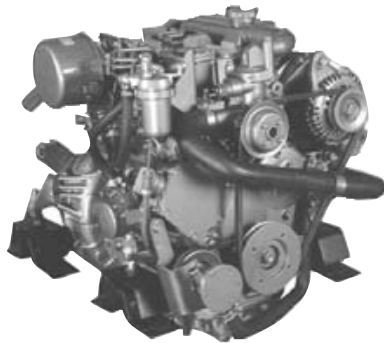

**YANMAR**  
marine 

P.O. BOX 2008 / 69 LIBERTY SHIP WAY • SAUSALITO, CA 94966  
Adjacent to Schoonmaker Pt. Marina

415•332•5478  
[www.listmarine.com](http://www.listmarine.com)

## LETTERS

formal yacht clubs. In other words, we were in the right place at the right time.

Not realizing how much work was involved in putting out a magazine — we'd been an indifferent Philosophy and Russian student at UCSB and Berkeley — we were briefly hospitalized for exhaustion prior to the completion of the second issue. By November of that year, the magazine had grown to a seemingly gigantic 72 pages, nearly double what we had hoped for in our wildest dreams. Exhausted once more, we flew to Hawaii to recuperate, and vowed to never do such a big issue again. Yeah, right.

As the magazine grew through the '80s and '90s, we continued to add employees. During the first 10 years, it was not unusual for the entire staff — then up to about 12 — to be up until 1 or 2 a.m., rushing around the rabbit warren of an old house/office we had acquired in Mill Valley, putting the next issue to bed.

For most of the run, we personally have had great but odd places to write. Following the advice of noted author James Michener, we'd put our typewriter (later our computer) on a piece of cheap Formica held up by two cheap file cabinets in a dark and windowless basement space. If you write, the last thing you want are views and other distractions.

Putting a magazine together was incredibly labor-intensive until technology really kicked in, so at one point we had 17 employees. We worship Apple, Google and other technology companies, for without them the magazine wouldn't be anything like it is today. In fact, it would have become fiscally untenable 15 years ago. The biggest issue of Latitude was over 300 pages and came out in the early '00s.

It goes without saying that the three most critical components to the magazine's 34 years of business have been a fabulous readership, great advertisers, and absolutely terrific employees. Without any of the three, we'd no doubt be enjoying ourselves cruising in the tropics somewhere.

For entire history of Latitude, the publisher has been the editor for all the Letters and Changes, in addition to writing feature articles and Sightings pieces. Although Latitude, like all publications, is smaller than it once was, in some ways its completion is a more difficult editorial task because we and our staff still want to get the same amount of factual information into less editorial space.

We've always thought of Latitude 38 as our 'art project' rather than a business, so we often went for many months without looking at 'the books'. We'd still rather get a root canal than look at the books.

Oddly enough, it took us the better part of 25 years to feel as if we really knew how to write. Prior to that it seemed as if we had to grind out the articles while trying to keep them funny. We finally think we've learned how to express ourselves clearly.

One of the unique things about Latitude is how personalized it's become, particularly through the editorial responses to letters. That wasn't planned, it just happened. The responses in Letters have always been the most popular feature of the magazine, but if at any point a large number of readers want to 'fire' us because they are sick of our opinions and/or responses, we won't be insulted or brokenhearted.

If we had a nickel for everyone who told us what a fabulous life we get to live, we'd actually be able to live that life. While it's true that we get to enjoy an inordinate amount of time sailing in great places and covering sailing events around the world, few people have any idea how much work or pressure is involved, and often under very trying — i.e. slow internet — circumstances. After all these decades, very intense 12-hour



# FURUNO®

Nice package!

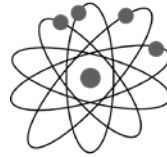

**RELIABLE  
MARINE ELECTRONICS**

(510) 864-7141



We REPAIR electronics –  
on your boat or at our shop.

1925 Lafayette St., Alameda, CA 94501

[www.reliablemarine.com](http://www.reliablemarine.com)

SALES • SERVICE • CUSTOM INSTALLATION

## RICHARDSON BAY MARINA

formerly Kappas Marina

MODERN FACILITIES IN A WELL-PROTECTED HARBOR

Concrete  
– Dock System

Well Maintained  
Facilities

Beautiful  
Surroundings

- DEEP WATER BERTHS:  
BASIN AND CHANNEL  
DREDGED
- CARD KEY SECURITY SYSTEM
- DOCK CARTS
- PUMP OUT STATION
- AMPLE PARKING
- CLEAN SHOWER AND  
TOILET FACILITIES
- WITHIN WALKING  
DISTANCE: MARKET/DELI,  
LAUNDROMAT,  
RESTAURANT
- AT EACH BERTH:  
LARGE STORAGE BOX,  
METERED ELECTRICITY,  
PHONE HOOKUPS, WATER

**BERTH YOUR BOAT IN SAUSALITO**

415 332-5510 [www.richardsonbaymarina.com](http://www.richardsonbaymarina.com)  
100 Gate Six Road, Sausalito • Fax 415 332-5812

**OIL PRESSURE GOOD,  
BLOOD PRESSURE GOOD.**

**VOLVO  
PENTA**

AUTHORIZED POWER CENTER FOR GAS & DIESEL



Call Us For  
Your Nearest Volvo  
Penta Dealer  
1-800-326-5135

Boating season is just around the corner. If you're feeling the pressure, relax. Leave it to us to go through your boat with a fine-tooth comb. Anything needs attention, we'll find it, and take care of it. Make an appointment today. Before the rush. It'll do your boat and your blood pressure a world of good.

**HELMUT'S**

MARINE SERVICE INC.  
Engines • Parts • Service • Worldwide Shipping  
**800/326-5135**  
San Rafael, CA • 415-453-1001 • [www.helmutsmarine.com](http://www.helmutsmarine.com)

## GREAT BOAT READING!

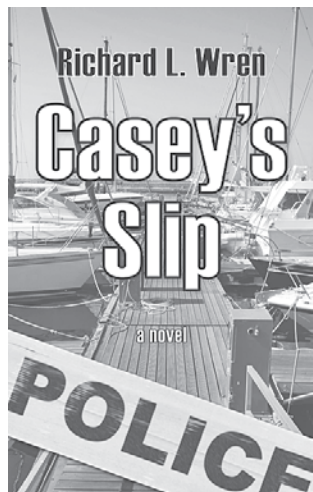

Oaklander Wren, a retired insurance exec who knows his way around The Town, has completed his first mystery book, which stars Casey, a 20-something sailboat bum caught up in a mysterious murder after delivering a boat under somewhat mysterious circumstances. The scenery is all Oakland, Alameda, and the East Bay. Right down to West Marine and *Latitude 38*. This yarn has

a cranky motorcycle gang leader, crooked cops and corrupt cops, plus a touch of romance and plot twists and turns. What more could you want for a little pleasurable reading? Kidnapping, blackmail, arson? You got it. So get it and enjoy the read.

— *Oakland Magazine*  
January/February 2012

Casey's *Slip* by Richard Wren available at:  
[www.poorrichardpublishers.com](http://www.poorrichardpublishers.com)

## LETTERS

days — weekends included — at the keyboard are still par for the course near deadline.

We started a number of charity sailing events from La Paz to Zihua in Mexico, where a little money can go a very long way in helping truly needy people. In '94 we started the Baja Ha-



**What gives us deep satisfaction? Other than our family, it's the joy so many people have gotten out of the Baja Ha-Ha, perhaps best expressed by this 'jumping for joy' shot of a bunch from last year's 'barely legal' Ha-Ha.**

Ha, which has hosted something in the range of 10,000 sailors on over 2,000 boats. It took us a few years to appreciate it but, if you will pardon our conceit, we think the Ha-Ha has evolved into one of the great sailing events in the world. Once again, it wasn't planned that way, it just sort of evolved. And it's almost all because of the quality of the participants. Since we were put on earth to help people have fun, particularly with their sailboats, the Ha-Ha has been an ideal vehicle for us.

We've owned about a dozen boats, from an Ericson 27 to three Olson 30s to an Ocean 71. We went over to the dark side in '96 by having the catamaran Profligate built in Long Beach. She's been the perfect Ha-Ha mothership, and our goal is to take 500 — maybe 1,000 — people sailing on her this year, hoping all guests will donate at least \$20 to their favorite charity. We also own the Leopard 45 'ti Profligate in a yacht management program in the British Virgin Islands, and we use it in St. Barth during the high season. Knock on fiberglass, but to date the program has worked out better than we expected.

People always ask us how much longer we're going to do Latitude and what we want to do next. We still love sailing, we still love writing about sailing, we still love sailing photography, and we still love doing layouts, so we'll probably maintain our course. But we want to do at least a couple of the four major regattas in Southeast Asia next winter, and we're planning on writing a book and making a supporting documentary, both of which are to be titled 4-3-12. Or maybe 3-4-12, we still haven't decided which we prefer. The book and documentary will be about the rewards of living in different cultures for significant periods of time each year.

Although we think of ourselves as being very liberal socially, we're also huge believers in personal responsibility. On the other hand, we're ultra-conservative fiscally, and believe that the noble calling of public service has, over the last couple of decades, devolved into a cesspool of racketeering and corruption on both the right and left. God help the future generations. In a more pleasant vein, our favorite sailing maneuver is gybing the symmetrical spinnaker.

We hope that covers it, because it's the last history we plan on writing. We sincerely thank everyone for their many years of astonishing support.

In a typical month, we receive a tremendous volume of letters. So if yours hasn't appeared, don't give up hope.

We welcome all letters that are of interest to sailors. Please include your name, your boat's name, hailing port and, if possible, a way to contact you for clarifications.

By far the best way to send letters is to email them to [richard@latitude38.com](mailto:richard@latitude38.com). You can also mail them to 15 Locust, Mill Valley, CA, 94941, or fax them to (415) 383-5816.

# Direct benefits

It's easy! With your new sail order from **North Sails Direct** you measure, you SAVE, you get the best. **Contact us today!**

**FREE!**  
ONE YEAR  
SAIL CARE  
& REPAIR  
with purchase of  
a new North sail\*

\*Restrictions may apply. Ask your North Sails Direct representative for details.

## NORTH SAILS direct

[northsailsdirect.com](http://northsailsdirect.com) or call 888-424-7328

Boat size restrictions may apply.



# The Cup is coming – slips are going!



**Making boating easier – and more fun! – is what Oyster Cove is all about.**

America's Cup boats are already here! Take advantage of Oyster Cove's great location. Near the races and practices, as well as SFO and mass transit, Oyster Cove is the private marina best for America's Cup convenience.

## OYSTER COVE MARINA

385 OYSTER POINT BOULEVARD #8A,  
SOUTH SAN FRANCISCO

**(650) 952-5540**

- Berths 30 feet to 60 feet
- Double Finger Concrete Slips
- Five Minutes from SFO
- Close to Mass Transit
- Heated Dressing Rooms & Showers
- Laundry Room
- Nightly Security Patrol
- Complimentary Ice

[www.oystercovemarina.net](http://www.oystercovemarina.net)



FREE QUOTES

**10,000 SAILS  
IN STOCK**

[www.BaconSails.com](http://www.BaconSails.com)

Search online – list updated daily

### BACON SAILS AND MARINE SUPPLIES

116 Legion Avenue Annapolis MD 21401  
**(410) 263-4880**

## Don't leave port without'm!

**#1**



Servo Pendulum with optional Emergency Rudder

The harder it blows, the better it works.

[www.selfsteer.com](http://www.selfsteer.com)

See over 5000 photos of boats with Windvane installations

**Built: Locally – Used Worldwide – Sold Factory Direct**

We are also the proud manufacturer of:

**auto-helm**

Auxiliary Rudder/Trimtab,  
no lines, emergency rudder

**Saye's Rig**

Pendulum Trimtab for hydraulic  
steering/high freeboard

**SOS** Emergency Rudder

Stand-alone, stows under  
deck, just like your life raft

We can supply the RIGHT Windvane/Emergency Rudder for your boat



Point Richmond, CA  
**510.215.2010**  
**888.946.3826**  
[scanmar@selfsteer.com](mailto:scanmar@selfsteer.com)

## banque populaire wins jules verne

On January 6, Loïck Peyron and his 13-man crew aboard the mighty 131-ft trimaran *Banque Populaire V* snatched the coveted Jules Verne Trophy from the grasp of Franck Cammas by completing a nonstop circuit of the globe in a record 45d, 13h, 42m, 53s. *Banque Populaire* beat the record set by Cammas aboard *Groupama 3* in 2010 by an impressive two days, 18 hours — not altogether surprising given the 700-mile days they put in.

*Banque Populaire* set off from Brest on November 22 and averaged 26.51 knots over 29,002 miles before passing the Lizard to claim victory. They broke four other speed records along the way — fastest to the equator, the Cape of Good Hope and Cape Leeuwin, and from equator to equator. “This has been an incredible trip around the planet, almost a dream ride,” said former Sausalito resident Brian Thompson, 49, who acted as helmsman and trimmer. “That’s because of the quality of the boat, the preparation, and most of all the incredible crew on board.”

Thompson, a Brit, has four nonstop circumnavigations under his Dubarrys, one of which was aboard the late Steve Fossett’s 125-ft maxi cat *Cheyenne* in ‘04. That 58-day circuit, which smashed the record by 13 days, should have earned the crew the Jules Verne Trophy but Fossett refused to pony up a fee to the trophy organization that was three times what the French competitors would have been charged. As a result, Fossett has essentially been written out of French sailing history.

— ladonna



Loïck Peyron and crew set a new record for a nonstop circumnavigation.

## circumnavigator celebrations

When one of the Bay Area’s most notable circumnavigators turned 90 last month, a highly spirited group of friends and family members turned out to help him celebrate. And we’re not surprised. After all, most if not all of them had sailed with birthday-boy Merl Petersen aboard his 75-ft schooner *Viveka* during the 54 years that he owned her. During that time he logged somewhere around 150,000 sea miles that included a seven-year circumnavigation.

We’d hoped to record Merl re-telling some of his classic stories — like the times that he and San Francisco nightclub owner Enrico Banducci (skipper of the 60-ft Alden ketch *Shearwater*) staged cannon battles off the Sausalito waterfront, and later promoted a waterskiing elephant that had the whole Bay Area talking. But there were so many other tall tales being told that day we decided to postpone our ‘oral history’ session with Merl until sometime this month.

We did get him to commit, however, to being an honored guest at our upcoming Circumnavigator’s Rendezvous at Strictly Sail Pacific on Saturday,

April 14. Plans are not fully formed yet, but we expect to hold some sort of gathering where West Coast circumnavigators can celebrate their accomplishments and share their experiences with wannabes — like ourselves. Look for updated info here next month.

— andy



Merl Petersen is 90 years young.

LATTITUDE, ANDY

## year of the

January 23, the Lunar New Year, ushered in the Year of the Water Dragon. In many Asian cultures, water dragon years — which roll around every 60 years — are a time of celebration and prosperity, with water playing a crucial role in taming chaos. Some believe that dragon years in general offer an opportunity for people to take more risks instead of simply accepting the status quo.

In honor of this centuries-old belief, make this the year you use your boat



*'Banque Populaire'* set five records on their speedy lap around the world.



## water dragon

boldly. Swallow the fear and enter a Hawaii race, singlehand for the first time, or simply anchor out overnight. Whatever sailing activity that makes your heart skip a beat or three, commit to trying.

As one Chinese horoscope site pointed out, "Prepare yourself for fast-paced, out-of-your-hands exciting times. All things are super-sized, prone to fanfare and filled with surprise during this Water Dragon year. How exciting it gets is up to you."

— *ladonna*

## a new year's delivery

When my friends Fred Garcia and Linda Mutter asked me to join them for their first major passage on their Taswell 43 *Perla Moon* from Sausalito to San Diego in early December, I jumped at the chance. But work and boat preparations kept pushing the departure date later and later. We finally settled on December 29, but when fellow crewmember Mike Clay and I arrived at *Perla Moon*, we saw Fred and Linda weren't quite ready. No one wanted another delay so Mike and I helped stow all the gear and provisions, as well as lash down the dinghy and jerry jugs.

It was dark by the time we finished. Naturally, there was discussion of waiting till the next day to leave, but I suggested we leave that night

continued on outside column of next sightings page



PHOTOS BENOIT STICHELBAUT, BRCE



# SIGHTINGS

## delivery — cont'd

since we had some momentum going. But, in the back of my mind, I was a bit worried the adventure would end badly and it would be my fault for insisting on leaving.

We shoved off around 10 p.m., and headed toward the Gate. The bridge towers, lit up by spotlights, eerily vanished and reappeared in dense fog. I'd been hoping to see the lights of Pt. Diablo and Pt. Bonita but there was nothing but fog. As a general rule, I won't sail into a wall of fog at the start of a passage, but considering the weather might not get any better — and most likely would only get worse — we decided to give it a go.

Linda and I worked the chartplotter and radar, giving Fred the course to steer. Right off the bat we had a near miss. Near Pt. Bonita,

continued on outside column of next sightings page

## mystery bottom

In the January issue of *Latitude 38*, we reported on this writer's final haulout in a four-year study on the effectiveness of the biocide Ecomea in bottom paint. Since the first haulout, we've been impressed with only one test paint — a water-based version — that consistently outperformed its fellow test paints and the copper-based control paint. The identity of each test paint's manufacturer was a closely guarded secret but study coordinator Jack Hickey agreed to ask Ecomea bigwigs to put us in touch with the manufacturer, at the

*Who says a winter delivery trip down the coast has to be ugly?*



PHOTOS TIM SELL



## paint revealed

very least, so we could effuse all over their paint.

Dave Janus, the Director of Sales & Marketing for Janssen PMP, the company that commissioned the study, worked his magic, and this was the very encouraging email we received recently from Pettit's Manager of Product Development, Frank Winkelman:

"The paint is currently in for EPA registration. If all goes well, we should have approval sometime in 2012. I have seen

continued in middle column of next sightings page



*'Perla Moon' was escorted by dolphins.*

*A little tidying was required before she left the dock.*

## delivery — cont'd

Fred and Mike said they thought they saw a light to port. Nothing showed up on the AIS, but I poked my head up in time to see the sodium lights of an approaching crab boat. Fred steered hard to starboard but the crab boat seemed to chase us through the fog like a pitbull. I think the fisherman was just having fun with us ragbaggers.

After clearing the ship channel and nearing the Lightbucket, we shaped our course south. I'd hoped to get us to deep water to avoid crab floats, but we turned a little too soon and had a nervous time dodging them until we got some sail up and killed the engine. We quickly got into the rhythm of the trip.

At some point every day of the 96-hour trip, visibility would drop to zero but, after our first interaction with the crabber, we learned to work the radar better. In all, probably 40% of the trip was spent in pea soup fog. Because there was little wind, fuel became an issue as we neared Southern California so we pulled into King Harbor. But of course, since it was New Year's Eve, the fuel dock was closed so we had to backtrack to Marina Del Ray.

We had a pleasant sail after getting fueled up, but the visibility closed out again and then it was back to motoring. One of the good things about voyaging on New Year's Day is that all the big ships were tucked into port — at least that's what the AIS showed. But radar showed something was shadowing us about a mile back in the fog. According to AIS, the *Catalina Flyer* was on an intercept course with *Perla Moon*, so we radioed the captain to make sure he had us on his radar. He did, then adjusted his course to make us feel better. He then advised the Coast Guard of his course change. Tellingly, the shadow radar target then seemed to lose interest in us and dropped back. I'm not afraid of a boarding by the Coasties, but I was glad we didn't get boarded at night in the fog.

The rest of the journey was relatively uneventful. It was great to enter warm, sunny harbors and see people enjoying paddlecraft wearing a minimum of clothing. I envied the fact that my friends would soon be heading off into the even warmer climes of Mexico.

Fred and Linda seemed to gain confidence with every mile of the trip south. On the last night of the trip they told Mike and me to sleep through the night. They'd taken ownership of their boat and no longer needed crew to offer advice or lash down a jerry jug.

— tim sell

## laura dekker, solo circumnavigator

Laura Dekker, 16 years and four months old, arrived at the Eastern Caribbean island of St. Martin on Saturday aboard her 38-ft Jeanneau Gin Fizz *Guppy* to become the youngest person to complete a solo circumnavigation. Dekker had wanted to start her adventure at age 13, but youth protection authorities in the Netherlands began a 10-month legal battle that delayed the start of her trip and forced her to acquire a larger and better-equipped boat. Still bitter about the government's action, Dekker says she'll perhaps move to New Zealand, where she was born aboard a boat to parents who split up long ago.

Jessica Watson of Australia had previously set the mark for the youngest solo circumnavigation with the S&S 34 *Ella's Pink Lady*,

continued on outside column of next sightings page



*Mike, Tim, Linda and Fred enjoyed a beautiful, if foggy, trip down the coast to ring in the new year.*

# SIGHTINGS

## dekker — cont'd

having gone around just a few months short of her 17th birthday. The Watson and Dekker circumnavigations are apples and oranges. Watson sailed nonstop via the much rougher Southern Ocean, and



COURTESY GUPPY

**Laura Dekker, 16, was greeted by her mother, sister and father when she arrived in St. Martin.**

completed the trip in 210 days. Dekker never did a longer passage than three weeks, stopped frequently, sailed a less arduous course, and took 361 days to finish (518 days, if you count the time it took to make her way from The Netherlands to St. Martin). This is not to denigrate what Dekker has accomplished, but simply to note that Watson faced a much greater challenge. Nevertheless, neither Dekker nor Watson will find her name in the World Speed Sailing

Record Council roster or the *Guinness Book of World Records*. Both record-keeping organizations are declining to maintain age-based records for sailing.

Authorities in the Netherlands were quick to commend Dekker on her bravery, skill and perseverance, but insisted they had been correct to intervene. "If Laura had drowned, we would be accused of not having done enough to protect her," said an official from the Bureau of Youth. She added that it's possible that Dekker made it around because they required her to sail a larger, more robust and better-equipped boat.

Just as we like to think that we can walk and chew gum at the same time, we like to think that we can both salute Dekker's accomplishment, but still object to age-based records based on principle. The history of people reaching personal peaks and gaining fame at a young age has been checked at best. We wish Miss Dekker every happiness in the world.

— richard

## we caught a fish . . . ewww!

If I had to choose between meeting a tiger or a fish in the wild I would definitely pick the tiger. I'm certain it would be less frightening than a real live wiggling squirmy ol' fish hanging from a hook. It may be painfully obvious, but my husband Conor and I are not fisherpeople. Our families don't fish. Our friends don't fish. And we managed to go through our pre-cruising life without reason to practice the sport.

In mid-April 2011, Conor and I bought our Islander 36 *Moondance* in Sausalito and by May we had decided to go cruising. Now. So we took the next six months to ready the boat and conducted our sea trials en route to Mexico. Considering we barely knew how anything except the sails worked, there was nary a chance to practice fishing down the coast — until we passed that magical invisible border in the ocean. I was so excited that I ran between the bow and stern yelling, "I'm in Mexico . . . I'm in America . . . I'm in Mexico again!" Mexican fishing licenses in hand, it was time to catch us some Mexican fishies!

Since crossing that invisible border in early December we have had only three days of fishing. The "only" was definitely on purpose.

Day 1: We catch an orange squid just south of Cedros Island. Since we aren't sure how to kill it, let alone prepare and cook it, we let it go. After consulting *The Cruiser's Handbook of Fishing* we find out that you kill a squid by stabbing it in the head with a knife. You

continued on outside column of next sightings page

## paint

your glowing reports on our water-based Ecomea product over the last few years — my local sales guys have kept me informed — and I will let you know when we obtain our EPA approval on this exciting new product.

"In the interim, we do have Ultima ECO, the solvent-based version of this product, which is available now. It was not one of the items included in the California testing but performs almost as well as the water-based Ecomea product, and it does meet all of the existing air quality rules





**— cont'd**

in effect in California. It's just days away from approval in California, but has been approved in just about every other state in the Union."

The bad news is that we'll have to wait a couple of years before our beloved water-based paint is available in California, but the good news is that the fresh bottom job we applied last month will last at least that long. And as soon as the product is released, our readers will be among the first to know.

— *ladonna*

**fish — cont'd**

don't say.

Day 2: Within five hours of leaving Turtle Bay we lose two lures. We see huge fish jumping up out of the water behind the boat, taunting us.

Day 3: We have a trolling line out yet again during our passage from Asunción to Bahía Santa María and, holy cow, it's taut. We reel the fish in, and it isn't even too hard. It's a good-size fish but not too big or intimidating. It's three feet away from the boat and all of a sudden pandemonium breaks out. What do we do? Where's the knife? Do we need the net? Where is that fishing book? I reel it in and let it back out again three times because I realize that I'm deathly afraid of this small animal and I'm not sure exactly what to do with it when it does come aboard.

continued on outside column of next sightings page



*The Corinthian Midwinters saw rare winter conditions: sun and wind. Check out Michael Moradzadeh's report in The Racing Sheet.*



# SIGHTINGS

## fish — cont'd

Once we finally have the fish on the boat, we decide to follow the guidance found in *The Cruising Chef Cookbook*. It advises us to stick the fish in a garbage bag to contain the mess, hit it over the head with a winch handle, and pith it with a screwdriver. Okay, we can do this. The fish goes into the garbage bag and Conor stabs it in the head with a screwdriver a couple of times.

We think the fish has died but it's just fooling us. As soon as we let down our guard it starts flopping around and jumps out of the bag. We stab it some more but it continues to squirm. We aren't killing this poor creature, we're giving it a lobotomy. We make incisions behind the gills but it continues to jump. Now blood and scales are all over the cockpit. This is not only completely gross but entirely traumatizing. The fish probably doesn't like it either.

continued on outside column of next sightings page

## cal boating on

Once again California politicians have set their sights on the Department of Boating and Waterways, a.k.a. Cal Boating. In his proposed state budget, Governor Jerry Brown wants to ax Cal Boating and reform it as a division of the Department of Parks and Recreation.

Of course the proposed elimination was suggested under the guise of "reducing duplicative staffing" but we believe the state merely wants the considerable funds brought in by Cal Boating — boater fuel tax, registration fees, and interest on infrastructure loans — distributed to a



Here, fishie, fishie (clockwise from here) — 'Moondance' would be a great fishing platform for some sailors, but not all; Conor's only bite turned out to be grass; Lanea brought in a not-so-tasty bonita; "WTF?!"; these are faces that a fish can trust.

SPREAD: ADAM CORREA; INSET: COURTESY YEMAYA





## chopping block

wider range of state programs in contrast to the original mandate that those funds be used for boating-related projects.

Killing off Cal Boating will not save the state a single dollar, but will almost certainly guarantee the reduction of boater services by allowing the department's funding to be managed by an agency that clearly has managerial issues, not to mention conflicting priorities. Boater education, loans and grants for boating infrastructure, pump-out stations, abandoned vessel removal and aquatic pest control

continued in middle column of next sightings page



## fish — cont'd

I'm sure that this fish will turn into a ghost and haunt us — if we ever manage to kill it. We leave it on the hook and throw it back over the side to bleed it. We're supposed to wait for 10 minutes but we're impatient so after five minutes we bring it back aboard . . . and the darn thing is still breathing! We stab it some more and make more cuts.

We decide to fillet the fish instead of gutting it. I cut into the sides of the fish while it is still breathing. I do a horrible job. The knife I'm using is a piece of garbage and I feel horrible wasting so much of this fish I just killed. I feel only a little better when Conor reminds me that it will feed other animals in the sea. I throw what seems like most of the fish overboard.

I have two small deveined fillets in front of me. At least I don't have to look at those sad, imploring little fish eyes any more. I slice the skin off and sauté the fillets in butter. Now to enjoy the fruits of our labor. We bite in to it and experience pure . . . nastiness.

It is so nasty that Conor immediately gags. He gulps down the rest of the ginger ale and a gallon of water. The taste turns my stomach and I can't eat for the rest of the day. I down half a box of Tic Tacs. This is so depressing. I'm so sad I want to cry. We killed this poor fish, probably filleted it while it was still alive, and then we threw the whole thing away.

I've since tried to figure out what went wrong. I think everything. We have not attempted to fish again. At anchor, we see fish play, dance, and jump out of the water all around us. They can tell we pose no threat to them.

— lanea riley

## will there be a seventh attempt?

During our travels around the Bay Area and beyond, *Latitude* editors meet a wealth of fascinating people. Eighty-four-year-old singlehander Tom Corogin is a perfect example. As you'll recall if you read our November 2011 interview with Tom, *Latitude* publisher Richard Spindler bumped into him in San Diego, and spent several wonderful hours learning about his colorful life the day before he was about to set off on his sixth attempt to 'conquer' Cape Horn — this time aboard his Westsail 32 *TLC*.

We're sorry to report that this spirited octogenarian's odyssey ended January 3, before he even reached the Southern Ocean. Not long after leaving Easter Island, the backstay supporting his deck-stepped mast failed, roughly 1,000 miles off the Chilean coast. When repeated attempts to jury rig it failed, he reluctantly assented to being rescued and abandoning his smartly equipped double-ender.

After *TLC*'s EPIRB signal guided a long-range Chilean Naval aircraft to the scene to survey Tom's situation, the 666-ft Japanese merchant vessel *White Kingdom* was diverted to pick him up. He was later transferred to a Chilean Naval vessel, which brought him safely to Valparaiso. In an Associated Press report Tom was quoted as saying, "I'm very grateful and I owe them the deepest respect and thanks."

Will he give up or try yet again? Time will tell, but we certainly wouldn't rule it out. Corogin is one tenacious solo sailer. After all, on his previous attempt last year he traveled all the way from his home base on Lake Erie to Panama via the Erie Canal, the Hudson River, Bermuda and the Virgin Islands. He broke his leg in Panama, but that didn't faze him. After it healed he continued on to the Galapagos, but had to turn back due to knee troubles.

If he does give up his Cape Horn dreams this time, it may be due

continued on outside column of next sightings page



Tom Corogin.

LATITUDE, RICHARD

# SIGHTINGS

## corogin — cont'd

to money rather than age. Because he was singlehanded, *TLC* was uninsurable, so a new attempt would mean starting over at square one. "I don't think age has anything to do with it," he told a reporter in Chile. "I think it's a matter of your life. I'm blessed: God has given me 84 years, and I'm trying to use them."

— andy

## who's in charge of a vessel?

We always assumed that it was a captain's decision whether to put to sea, particularly if bad weather is approaching. But that doesn't seem to be the thinking of British Admiralty Registrar Robert Jervis Kay.

In December 2006, delivery skipper John Anstess of Plymouth, England, and Southern Californian crew Dave Rodman and Richard Beckman, died when the 44-ft *Voyage 440* catamaran *Cat Shot* they were delivering for Reliance Yacht Management of Farnborough, England, got caught in a horrible storm off the coast of Northern California, capsized, and washed up on the beach. Apparently the boat was in something of a rush to be delivered in time for the Seattle Boat Show, although the show was nearly two months away.

The body of Anstess, 55, was never found. His sister sued Reliance in British Admiralty Court in September 2010. Some of the details of the case were just released, but to our mind not the most pertinent stuff. In justifying his decision, Registrar Kay said that Reliance had "pressured" Anstess, who had apparently suggested leaving the boat in San Diego for the winter, into continuing on toward Seattle. Kay went so far as to absolve Anstess, who everyone agreed was a highly trained and extremely experienced mariner, of even partial responsibility for setting sail into a tremendous storm.

Reliance responded angrily to the ruling. "Anstess was a true professional, and it would be a slight to his character to suggest that he would allow himself to put the crew and boat in undue danger for financial reasons or was pressured to do so by management or non-sailing administrative staff."

We wish the nature of the "pressure" on Anstess had been revealed in detail by Registrar Kay. Perhaps a gun to the forehead of Anstess' oldest son, if he had one, or a knife held to the throat of his mother. With all due respect to the dead, had we been in Anstess' Toppersiders, and had we had the weather information he had, we can't imagine anything short of preventing the murder of our family members that could have pressured us to put to sea from San Francisco Bay that morning. "Kiss our ass!" would have been our last words to Reliance after we

secured the cat to the dock and left town for somewhere warm.

We have no idea what *Cat Shot* crewmen Rodman and Beckman were thinking, and if they had objections to continuing. But according to the report in the January 2007 issue

of *Latitude*, the weather forecast showed a huge storm was on its way out of the Gulf of Alaska and was due to hit Washington and Oregon in just a few days. You just don't knowingly go out into stuff like that. Particularly in catamarans, which are not immune to flipping in severe weather. After all, it hadn't been that many years since a Lagoon 42 catamaran departed the Northeast on a delivery to the Caribbean in winter. She got into a bad storm, and neither she or her crew were

continued on outside column of next sightings page

## cal boating

in the Delta, as well as coastal beach erosion control, would all be in danger of neglect or elimination if Cal Boating was absorbed by the Parks Department. We can't imagine leaders in that agency will see potty docks as a priority when they're facing the closure of 70 parks in an effort to save \$33 million, can you?

This is the fifth time a California governor has tried to kill Cal Boating — Pete Wilson and Arnold Schwarzenegger both tried twice — but the state's boaters, a.k.a. voters, bombarded the governor's



LATITUDE ARCHIVES



'Cat Shot' landed on a Northern California beach.



**— cont'd**

office with visits, calls and emails opposing the cut.

At the risk of sounding melodramatic, it's imperative that we once again stand together against this attack on our sport and lifestyle. Download the Recreational Boaters of California's Call to Arms PDF at [www.rbo.org](http://www.rbo.org) (click the Call to Arms link), which includes a form letter to Governor Brown that RBOC will deliver. It's only a moment out of your day, but could benefit all boaters for years to come.

— *ladonna*

**in charge — cont'd**

ever heard from again.

Another consideration is that it's generally easier to go north from the Bay to Seattle in the winter because heavy weather is more predictable and there are often generous periods of calm between storms.

Clouding the situation is a previous incident that would seem to suggest that Reliance may have asked their delivery skippers to do unsafe things. Just two months before Anstess and his crew were killed, delivery skipper Steve Hobley of Newton Abbot, England, died when the 38-ft catamaran he was delivering across the Atlantic for Reliance was overwhelmed by 45-ft waves and capsized. The two crew, American Kevin Klinges and Ollie Templeman of Poole, England, hung on for 11 hours before the U.S. Coast Guard managed to rescue them.

continued on outside column of next sightings page



*The Japanese commercial vessel 'White Kingdom' rescued Corogin after his backstay failed. Inset, Corogin as he left San Diego, bound for Cape Horn.*

# SIGHTINGS

## in charge — cont'd

The cat was initially to be delivered across the Atlantic to Miami but part of the way across, Reliance told the captain to change course for the much more northerly Annapolis.

Any seasoned skipper knows that you don't deliver a boat across the Atlantic to north of Miami in the winter, and to Miami only because you can almost always quickly dive to the south if trouble starts heading your way. Call us chicken if you want, but had we been in Hobbey's shoes, and Reliance had told us to change destinations to Annapolis, we'd have had a simple two-word answer for them. The first would have started with an 'F', and the second would have ended with a 'U'.

According to news reports, crewman Klinges testified that Reliance told Capt. Hobbey that if he didn't divert to Annapolis, he wouldn't work for the company again. Shame, shame, shame on Reliance if that's true. But that should have been an idle threat, because who would want to work for a company that would request such a change

continued on outside column of next sightings page

## join the masses

For many sailors, joining long-distance races is more about the journey than the destination — but when the destination is Hawaii, well, all bets are off. Which is why this summer's Pacific Cup Race is already boasting an entry list of 48 boats — the same number that finished the race in '10 and one that has almost certainly increased by the time you read this. The first start for this biennial tradewind romp from San Francisco Bay to Kaneohe Bay on Oahu, which touts itself as 'The Fun Race to Hawaii', is July 16.

The Singlehanded TransPac, which heads to Hanalei Bay on Kauai on June 30, is also doing quite well for itself in regard to entries — 11 so far with quite a



SPREAD TIM WILKES, WWW.TIMWILKES.COM.; INSET COURTESY TEAM PREMIER NORCAL



## sailing to hawaii

few other sailors expressing serious interest.

Race Chair Rob Tryon believes the fleet will total about 20 boats by the time the start rolls around. "This race is really about the racers," he said, "so our focus this year will be on making this one of the most memorable times of their lives."

To date the race has attracted the following intrepid singlehanders:

- 1) Tom Watson, *Darwin*, Pearson Triton
- 2) Cliff Shaw, *Rainbow*, Crowther cat
- 3) Jen Mooney, *Little Bo Peep*, Ericson 27
- 4) Randy Leasure, *Tortuga*, Westsail 32
- 5) Peter Highberg, *Scaramouche*, Palmer Johnson 50
- 6) George Lythcott, *Taz!!*, Express 27

## in charge — cont'd

in route at that time of year? Once again, had it been us, Reliance would have gotten the same two-word response. We would have sailed the catamaran to Miami as originally planned, then chained the boat to the dock until we and our crew got paid in full.

It seems to us that the principle here is who is in the command of a vessel — and we're somewhat surprised to learn that a British Registrar apparently believes it's not the captain, but rather someone — perhaps not even a sailor — in a warm office thousands of miles from the boat itself. Does that seem as weird to you as it does to us?

We want to emphasize that we mourn for those mariners who lost their lives or suffered in these incidents, repeat that we're not privy to all the evidence, and acknowledge that hindsight is 20/20. Nonetheless, if the loss of these sailors' lives is not to be in vain, it will be because all other sailors will have learned that it's the captain of the vessel who should call the shots on the vessel he/she commands. After all, it's the life of his/her crew, as well as himself/herself, that is at stake.

We're interested in knowing what you think. Send your thoughts to [richard@latitude38.com](mailto:richard@latitude38.com).

— richard

## quantum key west 2012

Over the past few years, the infamous Key West Race Week has struggled to survive. But for its 25th anniversary, the event got a shot in the arm with a new sponsor and new name — Quantum Key West — as well as a passel of West Coast entries. In all, eight California-based campaigns hit the crystal blue Florida waters January 15-20.

Richmond YC's Buzz Blackett and Skip Shapiro chartered the Farr 400 *Team Premier*, which visited the West Coast for last year's Rolex Big Boat Series and Great Pumpkin Regatta. Sailing as *Team Premier NorCal*, she nabbed second place in the new five-boat Farr 400 class, after Joe Woods' *Red*.

"This was the first time that the five amateurs in the crew had raced in Key West," said Skip. "We found the level of competition, and number and skill of the professional sailors to be much greater than what we typically see on San Francisco Bay, including during Big Boat Series.

Skip reports that the fleet enjoyed "chamber of commerce weather" for the entire regatta, except for Wednesday's races being called due to fickle wind. "With a little more practice, or a few more races," he continued, "we might have even won our class — our scores for the last five races were identical to *Red*'s.

"Everyone on the crew had a great time. My only regret is that I didn't find a way to race here many years ago, and I hope to do it again as many times as I'm able."

St. Francis YC's John Kilroy of Malibu and his international pro-am crew on the Melges 32 *Samba Pa Ti* earned the Quantum Boat of the Week award (an honor they'd received in '10), in no small part for winning their 19-boat one design division by 12 points.

Another West Coaster to enjoy Key West was Rose Eberhard, a long-time member of Stockton Sailing Club who now calls San Diego home. Rose hopped a ride on Gerry Taylor's Annapolis-based Cape Fear 38 *Tangent* after her husband David, the manager of the San Diego West Marine Rigging Shop, was sent to Key West as support. "He got me a phone interview with *Tangent*'s tactician, who asked me to crew for them," recalled Rose. "I was ecstatic!"

After a full day at work, Rose caught a red-eye from San Diego, ar-

continued on outside column of next sightings page



**Representin'** — *Team Premier NorCal*, spread and above, were two of eight California-based teams to compete in Quantum Key West 2012.



COURTESY ROSE EBERHARD

**Rose Eberhard.**

# SIGHTINGS

## key west — cont'd

riving in Key West the next morning. "I went straight to the boat, and then we went out for the first day of practice in steady 30-knot winds," she said. "Despite my lack of sleep, I managed to survive."

The team obviously worked well together as they went into Thursday in the top spot, but a collision before the first start of the day dashed their hopes of winning their division. "We flew our 'I Flag' to accept the five-point penalty, but the opposing boat protested us anyway," Rose explained. "Both boats were disqualified. We were so disappointed."

But the team regrouped for Friday's races — "Everybody on *Tangent* was so serious" — and again won the day, securing their second-in-class finish. "I'm very proud that I did my best as a crew," said Rose. "And I've been invited back for next year's Key West Race Week as well as Charleston Race Week in April."

The other West Coast teams 'representing' in Key West were Santa Barbara's John Demourkas on a Farr 40 and his wife Deneen on Farr 30, both named *Groovederci*, Palos Verdes's Mick Shlens on the Farr 400 *Blade*, San Diego's Stephen Howe on the Melges 32 *Warpath* with tactician Morgan Larson, Costa Mesa's Bruce Ayres on the Melges 24 *Monsoon*, and L.A.'s Alan Field on the Melges 24 *WTF*. For full results, head on over to [www.premiere-racing.com](http://www.premiere-racing.com).

— chris

## a new home for ocean watch

When the 64-ft steel sloop *Ocean Watch* arrived beneath the Golden Gate in April 2010, even casual observers couldn't help but notice that it was a very special sailing craft. The massive silhouette of North, Central and South America emblazoned on her spinnaker belied the fact that she had nearly completed an ambitious 46-stop circumnavigation of the Americas promoting ocean education and conservation — the Around the Americas expedition.

A couple of days later, when the expedition crew made a presentation about their travels at the Corinthian YC, Captain Richard Gillette was in the audience taking in the multimedia show in awe. Afterwards,

he had a chance to tour the boat and chat with Project Director (and two-time solo circumnavigator) Mark Schrader. During that visit, and through subsequent conversations about Gillette's work taking disadvantaged kids sailing on the Bay, the two salts became fast friends.

Next month *Ocean Watch* will pass beneath the Golden Gate again. But this time she'll be making the Bay Area her new home base, as the flagship of Gillette's newly formed nonprofit Spirit of the Sea. Prior to branching out on his own, the Berkeley-based sailor had spent years captaining the 51-ft Alden ketch *Pegasus* for the nonprofit Pegasus

Project, which is focused primarily on educating youth from all social strata about our environment, the Bay and sailing — usually free of charge. With this larger vessel, which is capable of taking bigger groups on daysails and overnights, Gillette plans to extend the joys of sailing to an even broader audience, including kids of all stripes, veterans and those with physical disabilities.

Last month, Gillette's tireless dedication to his work earned him a prestigious Jefferson Award for outstanding community service. Created in the '60s by Jackie Kennedy and others, the purpose of these awards, which are awarded both locally and internationally, is to "recognize, inspire and activate volunteerism and public service

continued on outside column of next sightings page

## hawaii races

7) Alex Mehran, *Truth*, Open 50

8) Jim Quanci, *Green Buffalo*, Cal 40

9) Ronnie Simpson, *US 101*, Moore 24

10) Ruben Gabriel, *Rushmoore*, Moore 24SC

11) Al Germain, *Bandicoot*, Wyliecat 30

If you've been considering joining one of these great events, there's no time like the present to make the commitment. After all, nothing motivates people more than a deadline, especially when you've plunked down a fair bit of change to join



Capt. Richard Gillette.





## — cont'd

in the fun. And for both races, you'll save quite a bit by joining early — \$150 for Pac Cup and \$100 for the TransPac if you sign up by March 1.

Both events also offer great parties, including the TransPac's traditional 'tree time' on the beach, which will once again feature this writer's (in)famous 'LaDonna Tais' for refreshment. Check your liver at the door! See [www.pacificcup.org](http://www.pacificcup.org) and [www.singlehandedtranspac.com](http://www.singlehandedtranspac.com) for info.

— ladonna

## ocean watch — cont'd

in communities, workplaces and schools across America." On an international level, they are regarded as the Nobel Prizes of the public service arena.

"I am very humbled by this award," Gillette wrote to his volunteer *Pegasus* crew and supporters. "It really represents the work that we do together as a team/crew."

In *Latitude's* July 2011 tribute to unsung heroes of the Bay Area, volunteer Shana Bagley was quoted as saying, "There is something magical about Richard. He is like an old soul with a connection to the sea and the earth. The world is always brighter after spending time with him."

— andy



**Spread & above:** Battle-tested by thousands of miles of tough offshore sailing, 'Ocean Watch' will soon ease into her new role as a sail training vessel, accessible to a broad range of Bay Area kids and adults. Inset, left: First-timers learn the ropes aboard 'Pegasus'.



# THE YEAR

During the short, dreary days of winter, the minds of sailors naturally turn to salt spraying over the bow, on-board get-togethers with friends, and long weekends on the hook. Unfortunately, schedules can become so over-booked so early that sailors are often left daydreaming for much of the year.

Work, family commitments and outside interests (unthinkable!) can quickly monopolize a sailor's schedule so, as you begin planning your year, consider working at least one sailing-related outing into each month. Of course, getting your boat out of the slip would be ideal, but there are many sailing events in the Bay Area — and elsewhere — that don't even require your owning a boat.

The *Latitude* editorial staff have worked up a calendar of events that will keep you sailing all year long. And these suggestions are just the tip of the iceberg. Grab a copy of the *Northern California Sailing Calendar* at your yacht club or marina — or download it from [www.latitude38.com](http://www.latitude38.com) — for a comprehensive listing of nearly every race on the Bay, along with other notable events. Then keep your eye on each month's *Calendar* — also viewable online — to see what's happening. Just about every club in the Bay Area schedules events that are open to non-members, and chandleries host a variety of seminars throughout the year.

Keep your eyes and ears open to opportunities, and before you know it, your sailing schedule will be so full, you'll start daydreaming of things like . . . golf.

— **latitude 38 crew**

## FEBRUARY

- Trailersailer sailors won't want to pass up joining the **Havasu Pocket Cruiser Convention**, February 13-20, an easygoing and fun-filled rally on Lake Havasu (AZ) that attracts 200 boats. [www.sailhavasu.com](http://www.sailhavasu.com)



- Plan a romantic weekend with your sweetie at **Clipper Cove**. Take a tour of The Winery, then leisurely stroll through the Treasure Island Flea Market (February 25-26). [www.winery-sf.com](http://www.winery-sf.com), [www.treasureislandflea.com](http://www.treasureislandflea.com)

[treasureislandflea.com](http://treasureislandflea.com)

- If you missed the first installment of the wildly popular **Corinthian YC Mid-winters**, you won't want to miss the second one February 18-19. [www.cyc.org](http://www.cyc.org)



## MARCH

- The Richmond YC's free-of-charge **Sail-a-Small Boat Day** on March 3 is your best chance to try a wide variety of performance dinghies that are a vital component of a well-rounded sailing education. [www.richmondyc.org](http://www.richmondyc.org)

- Drop into *Latitude's* **Spring Crew List Party** at Golden Gate YC on March 7 to fill out your crew roster for the season. [www.latitude38.com](http://www.latitude38.com)



- Usually by this time of the year, we're ready to warm up a little, and there's no better place to do it than at **MEXORC** (March 11-17) a full week of warm, flat-water sailing in Banderas Bay with off-the-hook parties led by some of the friendliest hosts you'll find in the racing world. [www.mexorc.com](http://www.mexorc.com)

- While you're there, stick around March 20-24 for the **Banderas Bay Regatta**, five days of friendly racing for cruising boats. [www.banderasbayregatta.com](http://www.banderasbayregatta.com)



- BAMA's Doublehanded Farallones**

(March 31) is the first Farallones race of the year and always provides lots of on-the-water drama. [www.sfbama.org](http://www.sfbama.org)

## APRIL

- Strictly Sail Pacific**, April 12-15, is one of the best West Coast boat shows around. With seminars led by veteran sailors, parties both on the docks and in the exhibition hall, and great deals on boats, gear and just about anything that goes with them, it's a must-see event. [www.strictlysailpacific.com](http://www.strictlysailpacific.com)



- The **Bullship Race** (April 14) tests the skills of even the best sailors by putting them in El Toros and sending them across the Bay from Sausalito to the Cityfront. [www.eltoroyra.org](http://www.eltoroyra.org)



- Escape the hubbub of your normal routine with a leisurely sail up the **Petaluma River**, timed with the annual **Butter & Eggs Days Parade** (April 24), then overnight in the downtown turning basin. [www.visitpetaluma.com](http://www.visitpetaluma.com)



- April 29 marks **Opening Day on the Bay** — the official "start" to the Bay's



sailing season. [www.picya.org](http://www.picya.org)

- **Boater swap meets** are peppered throughout the Bay Area in the spring, so check *Latitude's* monthly *Calendar* for the where and when.



## MAY

- Explore the islands and villages of the Sea of Cortez while en route to Puerto Escondido, arriving in time for the annual **Loreto Fest** (May 4-6), where boatloads of sun-loving cruisers enjoy homegrown music, games and potlucks, in addition to participating in fundraisers for local charities. [www.hiddenportyachtclub.com](http://www.hiddenportyachtclub.com)



- Historically one of the most popular races on the Bay, the **Great Vallejo Race** (May 5-6) is a blast of a kite run from the Central Bay to Vallejo YC, where racers enjoy an epic party. [www.vyc.org](http://www.vyc.org)

- A local rite of passage for solo sailors is the Singlehanded Sailing Society's **Singlehanded Farallones**, May 12. [www.sfbaysss.org](http://www.sfbaysss.org).

- Your best lady might just come out of the Corinthian YC's annual **Women's Sailing Seminar** (May 19-20) a better



sailor than you! [www.cyc.org/wss](http://www.cyc.org/wss)

- Network among wooden-boat-loving friends for a ride in the annual **Master Mariners' Regatta**, May 26, or go out on your own boat to photograph this well-loved spectacle of classic sailing craft. [www.mastermariners.org](http://www.mastermariners.org)

- Before the summer marine layer dominates the coast, organize a **cruise-out to Santa Cruz**, ride the roller coaster to reset your synapses, then sail back home with an overnight at Half Moon Bay en route.

## JUNE

- Start your summer off right — and in good company — by sailing from Richmond to Stockton in the annual **Delta Ditch Run**, June 2. With any luck you can fly a chute much of the time, and afterwards you'll be in prime position to explore the Delta's backwaters. [www.stocktonsc.org](http://www.stocktonsc.org)



- Encinal YC's **Coastal Cup** (starts June 13) is famous for its typically taxing conditions during the roughly 300-mile race from the Bay to Southern California, giving you a chance to experience surfing conditions like you probably haven't seen before. [www.encinal.org](http://www.encinal.org)



- Take the family out for a daysail that includes a stop at one of the Bay's **boat-in restaurants**. You can find a complete list to print out and keep aboard at [www.latitude38.com/features/dining.html](http://www.latitude38.com/features/dining.html).

- If you've got friends who are 'jumping the puddle' to French Polynesia this spring, fly out to Tahiti and join them

in celebrating their crossing at the culturally rich **Tahiti-Moorea Sailing Rendezvous**, June 22-24. [www.pacificpuddlejumps.com](http://www.pacificpuddlejumps.com)



- Observe the Northern Hemisphere's summer solstice by joining in one of the many **Summer Sailstice** celebrations around the world on June 23. [www.summersailstice.com](http://www.summersailstice.com)

- Dubbed the "bug light for weirdos," the Singlehanded Sailing Society's **Singlehanded TransPac** starts June 30 and will put a hardy group of solo sailors to the test. [www.singlehandedtranspac.com](http://www.singlehandedtranspac.com)



- Lobby your favorite schooner skipper for a crew spot during the **Great San Francisco Schooner Race**, June 30, an eye-popping spectacle that features many of the West Coast's most meticulously maintained classics. [www.sfyf.org](http://www.sfyf.org)

## JULY

- **Beer Can racing** — weeknight sailing followed by social time — is getting into full swing by now; if you haven't tried one yet, you don't know what you're missing. Find the schedule in *Calendar*.





# THE YEAR

- Head up to the Delta to watch the spectacular **4th of July fireworks show** put on by Barron Hilton's family at Mandeville Tip.

- For those who don't want to go it alone, there's the **Pacific Cup**, a.k.a. "the fun race to Hawaii," which starts July 16-21. [www.pacificcup.org](http://www.pacificcup.org)



- The **Delta Doo Dah** (July 28-August 3) is so hot that it sells out within minutes of registration opening. Keep your eye on *Lectronic Latitude* this spring for the details. [www.deltadoodah.com](http://www.deltadoodah.com)

- The super-fun **Plastic Classic Regatta & Concours d'Elegance**, July 14, is strictly for "vintage" fiberglass boats designed at least 25 years ago — that's 1987, folks! [www.bvbc.org](http://www.bvbc.org)

- Year in and year out, the **Santa Barbara-King Harbor Race**, July 27-28, is one of SoCal's biggest distance races with one of its most picturesque courses. [www.sbyc.org](http://www.sbyc.org), [www.khyc.org](http://www.khyc.org)

## AUGUST

- There's no better test of one's heavy-air mettle than the Hood River YC's **Double Damned Race** (August 11) up the Columbia River. [www.hoodriver yachtclub.org](http://www.hoodriver yachtclub.org)



- The up-and-coming charity regatta, **Richmond Riviera Regatta**, features fantastic racing, the Taste of Richmond and a great party at Richmond YC, August 13-14. [www.richmondrivieraregatta.com](http://www.richmondrivieraregatta.com)

- We're not sure what you're planning to do August 11-19 and August 27-September 2, but our attention will primarily be on the two **America's Cup World**

**Series** events scheduled for those two nine-day periods. [www.americascup.com](http://www.americascup.com)



- Join hundreds of sailors in supporting the push to find a cure for Sarcoma Cancer by participating in the **Sarcoma Cup** races and shoreside activities at the Berkeley YC, August 25 & 26. [www.beatsarcoma.org](http://www.beatsarcoma.org)



- Take advantage of long summer nights with an overnight in the mooring field at Angel Island's idyllic **Ayala Cove**. After the last tourist ferry departs at 4 p.m., boaters have the grounds to themselves until twilight.

## SEPTEMBER

- Enhance your knowledge by picking the brains of Mexico cruising experts, and/or find a ride south of the border at *Latitude*'s annual **Mexico-Only Crew List Party**, September 5 at the Berkeley YC. [www.latitude38.com](http://www.latitude38.com)



- Take a road trip up the coast to Port Townsend for the **Wooden Boat Festival** (September 7-9). If wooden boats make your heart flutter, even a little, this event is a must. [www.woodenboat.org/festival](http://www.woodenboat.org/festival)

- After watching the America's Cup World Series, chances are you'll have

an appetite for some racing of your own, and the St. Francis YC's **Rolex Big Boat Series** (September 6-9) is just the ticket. The premier regatta on the West Coast is one of the best to sail, and finishes right in front of the club make for some great spectating as well. [www.rolexbigboatseries.com](http://www.rolexbigboatseries.com)



- Give back a little on September 15 by joining your local **Coastal Cleanup** team to clear beaches of trash. [www.coastalcleanup.org](http://www.coastalcleanup.org)

- Catch a ride aboard San Francisco Maritime National Historic Park's **scow schooner Alma** for a three-hour tour of the Bay. Rides are offered throughout the summer. See [www.nps.gov/safr](http://www.nps.gov/safr) for a full schedule.



- When you're planning your trip home from the Delta, schedule it around the **Delta Blues Festival** (TBD) at Antioch Marina. [www.deltabluesfestival.net](http://www.deltabluesfestival.net)

## OCTOBER

- See the full might of American strategic superiority on display and help support the U.S. Navy at **Fleet Week**, October 4-8. [www.fleetweek.us](http://www.fleetweek.us)

- Test your shorthanded sailing prowess by racing in the **Vallejo 1-2** (October 6-7), which is unique within the Bay racing calendar. Saturday's race, from the Berkeley Circle to Vallejo YC, is raced singlehanded, while the Sunday race, Vallejo to Richmond YC is raced doublehanded. And a bonus is that you get to party in two different YCs. [www.ryc.org](http://www.ryc.org), [www.vyc.org](http://www.vyc.org)

- The **Pink Boat Regatta** (October 14), the newest charity race on the Bay, offers



# IN PREVIEW

a crazy course, colorful games, and vivid memories, in addition to raising funds for the Breast Cancer Research Foundation. [www.thepinkboat.org/regatta](http://www.thepinkboat.org/regatta)



- Hands down the most successful **Leukemia Cup** (October 21) in the country, the San Francisco version of the event raised over \$1 million last year for research. [www.leukemiacup.org/sf](http://www.leukemiacup.org/sf)

- As one of the summer racing season's bookends, the Richmond YC's **Great Pumpkin Regatta** (October 27-28) is a must-do event. With 258 boats at last year's, there should be no shortage of ride opportunities. But even if you can't get a ride, you don't want to miss Satur-

day night's party. [www.richmondyc.org](http://www.richmondyc.org)

- In the days leading up to the Baja Ha-Ha, the **Downwind Marine cruising seminar series** offers tons of tips and wisdom to folks heading south. [www.downwindmarine.com](http://www.downwindmarine.com)



- Declare an end to procrastinating and head south — on your own boat or a friend's — with the annual **Baja Ha-Ha** cruisers rally from San Diego to Cabo San Lucas, October 28-November 10. [www.baja-haha.com](http://www.baja-haha.com)

## NOVEMBER

- November marks the beginning of the Bay's various **Midwinters** series.

If you haven't tried racing the Bay in what are usually very relaxing, enjoyable conditions, you owe it to yourself to take a stab at it. Find a full schedule in *Calendar*.

## DECEMBER

- Decorate your boat for a **lighted boat parade**, join and make merry! A full schedule will be listed in *Calendar* and in *'Lectronic Latitude*.



- Splurge and take the family on a **sailing vacation to the Caribbean** that will yield unforgettable memories.

## COME VISIT COYOTE POINT MARINA

*The Peninsula's Complete Recreational Destination!*



**Multihull  
Side Ties Available  
up to 40 ft.**



### **BERTHING**

- Slips to 40' available
- Inside ties from \$100 per mo.
- Multihull side ties available
- Check out our rates!



### **FUEL DOCK & PUMP OUT**

- Open 7 days per week
- Gas and diesel available
- Check our prices
- Free pump outs

COYOTE POINT MARINA ~ 1900 Coyote Point Drive • San Mateo

**650.573.2594**

# ROB MOORE — CONNECTICUT YANKEE

The sailing community lost a favored son last month. *Latitude 38* lost a treasured former colleague, and scores of sailors around the nation and the globe lost a personal friend with the passing of Rob Moore, who died peacefully at home on the afternoon of January 5, surrounded by family.



ALL PHOTOS COURTESY LESLIE RICHTER

**A consummate joker with a razor-sharp wit, Rob will be remembered for his keen sense of humor as much as for his sailing prowess.**

Robert Kent Moore was born on September 26, 1953, in New London, Connecticut, to Kent and Marge Moore. He and younger sister Marnie were raised in Mystic, and their playground was the waters nearby. Rob was a mischievous and energetic youngster, always pushing the envelope for new adventures. His parents were avid sailors on Long Island Sound (young Rob helped his father build several boats in the backyard) and introduced the children to sailing at an early age.

Rob loved sailing from the start, but became easily bored by the sedate pace of cruising and daysailing. His penchant for more excitement soon had him seeking spots on racing boats, where he was a quick learner. By the time Rob enrolled at Brown University, where he would earn a degree in American Civilization, he was already an accomplished sailor and a member of the Brown Sailing Team, along with Eric Kreuter, Brad Dellenbaugh, John Burnham and others. By the time he got his MBA from Columbia, he had several Block Island Race Weeks and Bermuda Races under his belt, and was a sought-after crew and delivery skipper.

Rob first came to San Francisco in

1978, ostensibly to look for a job in finance, but also because he wanted to see firsthand this place where they said the wind blew hard all summer and the tides ran strong. He was not disappointed. His first few sails were aboard various boats, but his first regular big-boat ride was with Bill Twist on Bill's Peterson 3/4-tonner *Stuff*. Rob became so hooked on local sailing that his family remem-

*Rob loved sailing from the start, but became easily bored by the sedate pace of cruising and daysailing.*

bers he didn't even come back home to pack up the rest of his possessions. He just found a job (eventually working for Twist) and bought new clothes and other necessities as he needed them.

The first boat Rob owned on the Bay was *Urban Guerrilla*, a well-used Santana 20 that had achieved minor notoriety by broaching and sinking during a race on the Berkeley Circle. (There's a great photo taken by legendary Bay sailing photographer Diane Beeston of just the top 4 feet or so of the mast and sail sticking out of the water.) As the story goes, the then-owner tied a floating bottle to it, collected the insurance, went out and raised the boat, hosed out the mud — and sold it to Rob.

Within a year of moving west, Rob met designer Carl Schumacher. The two immediately hit it off and became close friends. Rob eventually bought *Summertime Dream*, the 26-ft quarter-ton designed and put together by Schumacher in 1979. The boat's win in the Quarter Tonner Nationals that year launched Carl's career as a naval architect.

Schumacher was a huge help in 'educating' the Connecticut Yankee in how to sail the Bay's tricky waters. Rob and Carl sailed together many times, and Carl even 'awarded' Rob one of the first major trophies the boat won, which was a half-hull of *Summertime Dream*. No matter where he lived, Rob hung that half-hull in a place of honor in the house, while most of his other silverware from various races — and there was a lot of it — languished on shelves or counters filled with paper clips or M&Ms.

Over the next 20 or so years, Rob also owned and sailed *Sundance* (SC 27), *Grumpy Old Men* (another Santana 20), *Confederacy of Dunces* (Holder 20) and

*E Ticket* (Olson 25).

One of the great Rob stories was that he 'owned' *Summertime Dream* three different times. Rob financed the first two sales himself. The first owner defaulted on the note and gave the boat back. The second time it went to a rich kid from Brazil (who painted it dark blue and affixed the giant letters BRA to the mainsail). He offered to trade it back to Rob for a Hobie 16! So Rob struck a deal with Seabird Sailing Center in Berkeley for a new Hobie Cat — and got the 'Dream' back again. The third sale was a charm, because it 'stuck'. Notably, Rob sold the boat at a profit each time. (See our feature on this boat in the July 2011 edition.)

Rob first came to the attention of *Latitude 38* when he won his IOR class on *Summertime Dream* in the mid-80s and was featured in our Season Champi-





# IN KING NEPTUNE'S COURT

ons series. (This writer recalls his initial impression of Rob as being a cross between a red-haired Mark Twain and the Lion King.) Rob later submitted an article on the 12-Meter Worlds that appeared in the March 1986 edition. Ever one to buck tradition, Rob finally said good-bye to the world of high finance (where he once received a new BMW as a holiday bonus) and hello to the ink-stained, midnight-oil-burning, largely thankless life of a journalist in October of the next year, when he was hired to be *Latitude's* new racing editor.

By that time, Rob had done more racing, and knew more about racing — locally, nationally and internationally — than the entire rest of the staff combined. And that included all the past employees.

**With Robin Sodaro driving and Tom Leweck checking traffic aft, Rob trims the kite aboard Damon Guizot's Swan 53 'Katrina' during the 2009 Antigua Sailing Week.**

Among the many Left Coast events on his resume by then: A Puerto Vallarta Race (on the SC70 *Citius*), two Cabo Races (Express 37 *ReQuest* and Farr One Ton *White Knight*), two TransPacs (one aboard E37 *Morningstar*), a Kenwood Cup (*Bladerunner*, Bill Twist's then new R/P 47), a handful of Big Boat Series (most aboard *Bladerunner*) and literally every local event on the Bay and in the ocean — back when the latter included brutal, boat-busting 100- or 200-mile courses like the Buckner and Jr. Waterhouse. Once asked if he knew the date that the Australians finally wrested the America's Cup away from the New York YC, Rob immediately replied September



**In addition to sailing whenever he could, Rob loved outdoor sports like kayaking and hiking — especially up in the San Juan Islands.**

26, 1983. When asked how he knew that, he said, "That was the day we got dismasted on the ocean aboard *Summertime Dream* and had to be towed in by the Coast Guard. Oh, and it was also my birthday."

By the time he stopped making entries in his sailing resume in 2009, Rob had compiled at least a dozen Coastal Cups, 10 MEXORCs, six Ensenada Races, two Swan Worlds (in Sardinia), four Bermuda Races, two Pacific Cups (aboard the Schumacher 50 *Morpheus*), several Key West Race Weeks, and one each: Antigua Race Week and Pineapple Cup (Ft. Lauderdale to Montego Bay, Jamaica, through the famed Windward Passage). He was a two-time winning crew (for Paul Cayard and Ed Baird) in the Bitter End YC Pro-Am, and a four-time winning crew for John Jennings in the St. Francis International Masters Regatta.

That's not to mention the many races he also sailed locally, or the fact that

*"That was the day we got dismasted on the ocean aboard 'Summertime Dream' and had to be towed in by the Coast Guard."*

Rob often delivered the boats he raced on back from Mexico, Hawaii, Florida or other ports. Or the time he devoted to race management at the Sausalito YC and later Corinthian YC. (He was also a member of the Storm Trysail Club.) Or his longtime duties on the Bay Area PHRF Committee. Or his many years of being part of the selection committee for the Rolex Yachtsman/Yachtswoman of the Year awards.

His rides varied from small craft —





# ROB MOORE — CONNECTICUT YANKEE

like *Confederacy of Dunces*, which he trailed to various venues on the Lake Circuit, to big boats like Swans (including *Money Penny*, a Swan 601), and sleds (various SC 70s and the N/M 68 *Pandemonium*). Favorite boats/campaigns/crews over the years included Twist's *Bladerunner*, Lew Beery's Andrews 43 *It's OK!* and with Jim Gregory on both big and small boats: *Morpheus* and *Agent Smith*, an Etchells.

It's also noteworthy that Rob taught sailing, acted as a mentor/coach to many young and/or aspiring sailors, and was a 'master of introductions', whose instinct for matching up people led to many harmonious crews — and to changing many lives for the better. A good example is Jim Gregory. Years ago, Rob taught the 14-year-old Jim to sail. ("He now teaches me," Rob noted a few years ago.) Then, when Gregory moved west, Rob introduced him to Carl Schumacher, which years later led to the design and building of *Morpheus*.

"Rob was always my favorite person to sail with," recalls Jim. "He was the first person I called when I started to pull a racing crew together for *Morpheus*, and he was always the key member of the crew around which everyone rallied."

Epic non-racing highlights of Rob's long sailing career include an all-expenses-paid press cruise to Australia's Whitsunday Islands (he still found it hard to adapt to the relaxed cruising lifestyle), and a Florida-to-Connecticut delivery with Eric Kreuter in hellacious conditions "when we were in college and didn't know any better." ("We were losing crew at every stop," recalls Eric. "Only

***One of the best things that ever happened to Rob was meeting the lovely and talented Leslie Richter, who became the love of his life.***



ALL PHOTOS COURTESY LESLIE RICHTER

Rob and myself were left when we arrived in Greenwich.") The wind instruments blew off the mast, but later weather reports indicated the young sailors were pounding north in as much as 60 knots.

**R**ob's 18 years at *Latitude 38* were rife with stress, long hours, occasional all-nighters, 'deadline dinners' consisting of a family-size bag of Fritos and a six-pack of Bud, epic writing, epic friendships, epic creativity, and lots of laughter. Lots of it.

As a writer, Rob was a natural. Right out of the blocks, he had a great feel for the amount of coverage each event deserved. His already encyclopedic knowledge of racing came through with each piece, and he was so fanatical about getting things right that — more than once — he called a source very late, sometimes literally at midnight, to check the spelling of a crewmember's name. ("Is that Tracy with an 'i' or a 'y'?"

Rob's integrity in matters of writing — and life — set the bar high, and elevated all of the writing at the magazine, particularly his oft-phrased admonishment to "add value." To Rob, it made no sense to run something like a press release verbatim. His reasoning was that it was probably going to appear in 100 other publications, and that just "parroting" it added no value. So he add-



***One of Rob's best friends and most valued mentors was Hank Easom. They raced together often aboard Hank's 8-Meter 'Yucca'.***

ed value — by calling all the principals involved in the release and constructing more of a true article out of it, which usually included much more pertinent and up-to-date information. His original articles were the same way. Everything Rob wrote added insight — and value — to the event and the sport as a whole.

Rob's writing expertise extended beyond recapping single regattas. When 9/11 happened just two days before the 2001 Big Boat Series — and that year's regatta was appropriately cancelled — we were all in shock like the rest of the

***As a writer, Rob was a natural. Right out of the blocks, he had a great feel for the amount of coverage each event deserved.***

world. But at *Latitude*, we also now had eight blank pages to fill. In just a few short days, Rob put together the Big Boat Series Retrospective, one of the most fun, bittersweet and entertaining pieces ever to run in the magazine. While tracing the BBS from its origins in the '60s to present day, Rob hit all the right



# IN KING NEPTUNE'S COURT



buttons and ran all the right photos, mentioning such legendary boats as *Baruna*, *Imp* and *Kialoa*, and running photos of 'young guns' like Dave Ullman, Dennis Conner and Tom Blackaller back when they were still considered mortals.

And when that weather bomb exploded on the 1998 Sydney-Hobart Race fleet, taking the lives of six sailors with more than 55 others being airlifted off maimed and sinking boats, Rob wrote that story, too. To this day, it is the most concise, accurate and dramatic account of that tragedy short of

the book that came out later.

One editorial venture that Rob was particularly proud of was creating the *Ten Commandments of Beer Can Racing* which we still re-run annually.

The most difficult assignment Rob ever had? The memorial article he wrote about friend and mentor Carl Schumacher after Carl's untimely passing in early 2002.

Rob left *Latitude 38* in the fall of 2005. He continued to sail throughout most of 2011, preferring in this phase of life to 'go retro' as part of Hank Easom's crew on the lovely 1937 8-Meter *Yucca*. After all was said and done, after all the big boats and all the great rides and venues he'd experienced, *Yucca* may have been Rob's all-time favorite ride, largely because of the friendship he'd developed over the years with Easom.

In the summer of 2009, Rob developed a persistent cough. When it wouldn't go away, he went to the doctor. Three times he was told it was nothing serious, given medication, and sent home. The cough persisted. Urged to get a second opinion, he did, and it was a shocker. In late '09, he was diagnosed with Stage IV lung cancer — the most advanced stage. He'd never smoked. He was given nine months to live.

He responded well to the initial chemotherapy regimen. His cough went away and he resumed an outwardly robust ex-

*After all the big boats and all the great rides and venues he'd experienced, Yucca may have been Rob's all-time favorite ride.*

istence. The chemo, combined with living clean, eating healthy, and the love and devotion of his wife Leslie allowed Rob to lead a mostly normal life for two more years. Even the doctors were amazed.

To say he treasured every single day of the time he had left would be an un-

derstatement.

Besides sailing, it was time enough to devote a few more months to another of his loves — hiking and enjoying the outdoors. "Although his career and most of his free time was dedicated to sailing, spending time in the wilderness fed Rob's soul," wrote wife Leslie on the blog-journal "Rob's Adventure — Sailing Upwind In A Storm" ([rkmoore.wordpress.com](http://rkmoore.wordpress.com)), which they put together to keep friends informed of Rob's condition. Over a period of several years, Rob and Leslie had begun construction of a yurt on a remote piece of land in the San Juan Islands. They dedicated time to finishing it, and spent many a summer month living and hiking in the surrounding wilderness.

Closer to home, they made regular treks to Mt. Tam and other nearby hiking grounds such as Yosemite. But what Rob

## REMEMBERING ROB

*The following are excerpts of remembrances from some of Rob's friends and crewmates. For more, including some hilarious stories from former and current Latitude staffers, see our online tribute to Rob at [www.latitude38.com](http://www.latitude38.com).*

*From "Brother" John Gladstone — Some people reading all this stuff about Rob, who did not know him as I and others writing in did, may not get how significant he truly was to those he touched. Someone else said it so well: He made each and every one of us feel more special than we ever felt about ourselves. "I am not worthy," he would say. Guess what? If worthy means having spent time with you Rob, we are so worthy!*

*Dave Gendell of Spinsheet Magazine — In the early years on the judges' panel for Rolex Yachtsman and Yachtswoman of the year Rob and I had never met in person, but I knew him by reputation and through the occasional battered and fetishized copies of *Latitude 38* that made their way east back in those days. I completely respected his work and his offbeat vibe. (To wit: He once published a race story featuring a headline lifted from an obscure lyric from The Doors: "Weird Scenes Inside the Gold Mine.")*

*... I was young and I loved *Latitude 38*. It was Rob I wanted to connect with more than any celebrity editor from Newport or any "full access" mainstream media guy.*

*Dana Paxton of Media Pro International — While I was well aware of the scope of *Latitude 38*, it wasn't until I met Rob a year or so into the job and watched him work the dock among thousands of sailors that I truly understood how much he knew about racing on the West Coast (and beyond). He quickly became my go-to guy for trivia, history or an inside scoop that might help me do a better job for the St. Francis YC and the regatta. All I had to do was call or write and name a sailor, race or boat class, and the encyclopedia in Rob's head would open.*

*Philip Lotz — Although I got to know him for only a short time, it is easy to see why there is such an overwhelming outpouring of tributes to Rob. All the statements in *Scuttlebutt* and elsewhere are true — he was great to sail with and a treasure of a person on and off the boat. . . . He made a huge impact on our team and will be remembered and missed by all of us on *Arethusa*.*

*Kirk Denebeim — Having re-entered the Bay racing scene in 2011 after a 20-year hiatus, I had the pleasure of chatting with Rob at a regatta last July, and catching up a bit. He vaguely informed me that he was battling some health problems, but honestly, I did not appreciate that it was as serious as lung cancer. His spirits, demeanor, smile, bottomless wit — and those twinkling blue eyes — gave no hint that it would be our final conversation.*

*Lucie Mewes — I got my second Beer Can tiara (for completing a beer can race every night of the week, within a single week) because of Rob's goading. He got me to say "yes" to the challenge, which got me to do a lot more sailing and meet so many new folks.*

*Pat Broderick — I first met Rob at the Sausalito Cruising Club when I was running and sailing races down there. He was young with wild red hair and a strong voice at the bar. And he was one hell of a sailor. He'd offer helpful suggestions for managing races better — and I even listened to some of them.*

*Mark Joiner — I'm so sorry to hear of Rob's passing. I didn't know him well but always enjoyed his articles, which is saying a lot for a long-confirmed non-racer such as myself.*

*Capt. Robert Strang — Rob was the consummate sailor and fellow crewmember, from my experiences with him in Puerto Vallarta to our beloved Balboa YC and the Bay Area. If Rob wrote it,*

# ROB MOORE

then it was the bottom line! His memory will be with all of us forever.

*Jim Bateman* — Rob and I once sailed *Urban Guerrilla* out to the first approach buoy out the Gate, just to ride the swells back in.

Since *UG* was named after Patty Hearst, we sometimes entered the boat's name under the SLN — Symbionese Liberation Navy. An explanation is probably in order for his use of SLN, as well as the Down Town Yacht Club, the Brown Trout Yacht Club, Spooge, and Spooge 3 syndicates when he raced. These were all used in fun, but really because Rob never liked to publish his own name as the winner in *Latitude*.

*Pete Caras* — One time, Rob came by *Foxen* to try to entice Tracy and me to do a Corinthian Friday night race with him aboard Richard Spindler's Olson 30. Tracy wasn't into it because she felt Rob was too intense when racing and told him so. Rob held up two six-packs and promised it would be a fun, relaxed evening, so Tracy said, 'Let's do it.' All was well until the starting gun went off and Rob had us working our asses off like it was the America's Cup! We won our division and Rob was so stoked he sprang for dinner.



COURTESY DAVE GRUVER

**Shortly after Rob passed, his sailing buddy Dave Gruver (standing, white cap) and his crewmates made a 'stache' tribute to their red-haired friend during a Sausalito YC Midwinter Race.**

relished most were his trips to southwest Utah to visit places like Moab, Red Rocks and Indian ruins — former stomping grounds of his favorite author, Edward Abbey, who wrote Rob's favorite book, *Desert Solitaire*. Among the many memorable word images from that book:

"May your rivers flow without end . . . where storms come and go as lightning clangs upon the high crags . . . where

something strange and more beautiful and more full of wonder than your deepest dreams waits for you — beyond that next turning of the canyon walls."

Fair winds, old friend. Thanks for adding value to all of our lives. The world will not be the same without you.

— **latitude/jr**

*Rob is survived by his wife, Leslie, mother Marge, sister Marnie, her husband, Scott, and her children Philip and Katherine. Anyone interested in honoring Rob with a donation is encouraged to do so in his name to the National Lung Cancer Partnership, ([www.nationallungcancerpartnership.org](http://www.nationallungcancerpartnership.org)), Hospice By the Bay ([www.hospicebythebay.org](http://www.hospicebythebay.org)), or through a special fund set up at the Marin Community Foundation ([www.marincf.org](http://www.marincf.org)).*

*Tiburon's Corinthian YC will host a celebration of Rob's life February 12, 2-5 p.m. "All friends are invited to attend," says Leslie. "Crew shirts are encouraged, and ties are prohibited."*

## NOT JUST INSTALLED — ENGINEERED!

*There's a difference.*

It's more than drilling holes. Easom Rigging has a naval architect and marine engineer on staff to get it right.

- Efficient Layouts
- Ergonomically Correct
- Properly Sized

Well-engineered products deserve well-engineered solutions. If you think it costs more — it doesn't.

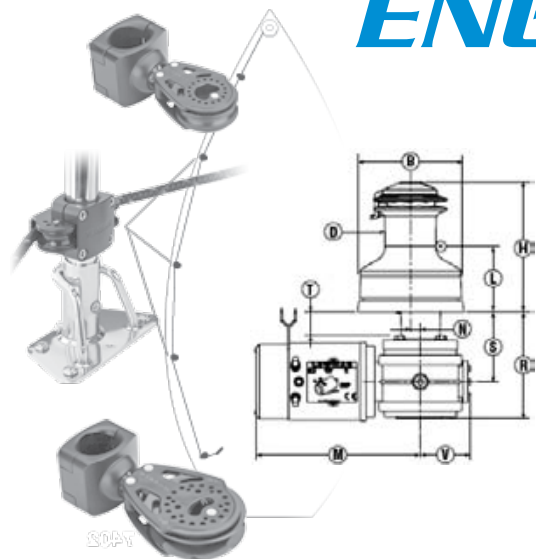

**Better final solutions at better final prices.  
Call for a estimate!**



[www.easomrigging.com](http://www.easomrigging.com)  
(510) 232-SAIL (7245)

**Easom Racing and Rigging**

1230 Brickyard Cove Rd., Suite 102  
Point Richmond, CA 94801





North U

# SEMINAR 2012 TOUR

The *Fastest!* way to get more out of your sailing!

For registration, seminar updates

[www.northu.com](http://www.northu.com) 1-800-347-2457

See our entire schedule of Seminars and Webinars across the country!

### Seminar and Webinar Schedule as of 1/17/12

Check NorthU.com for additions and changes

#### Trim Seminars

Marina Del Rey CA.....Feb 11  
 San Francisco CA.....Feb 25  
 San Diego CA.....Mar 4  
 Seattle WA.....Apr 1  
 Cruising Seminars  
 Seattle WA.....Mar 31

#### Webinars

Trim (all day).....Mar 24  
 Trim (eves).....Mar 27, 29  
 Weather (morns).....Mar 10, 17  
 Weather (eves).....Mar 13, 20  
 Racing Software (eves).....Apr 23, 26  
 Newport Bermuda Strategy (eves).... June 4, 11

North U. Trim or Cruising Disc is included with the seminar. Coursebooks can be added or purchased separately at [www.northu.com](http://www.northu.com).



Member Discounts



You can spend a lifetime learning to be a better sailor...we accelerate the process!  
Bill Gladstone, North U. Director

Sharon Green photo

Quality Since 1986



## Ventura Harbor

B O A T Y A R D

Haul Outs To 160 Tons

(805) 654-1433

1415 SPINNAKER DRIVE  
VENTURA, CA 93001

[WWW.VHBY.COM](http://WWW.VHBY.COM)

[info@vhby.com](mailto:info@vhby.com)



## Ballenger Spar Systems, Inc.

Custom Racing and Cruising Spars  
Expert Design and Consultation

- Carbon and Aluminum spars
- Rod and wire rigging
- Hi-tech and conventional halyards
- Spar kits, extrusion
- Repair and modification
- Custom fabrication, waterjet and CNC
- Hardware, sheaves, spreaders
- Bay Area pick-up and delivery
- **Discounts** on halyards, standing rigging, deck hardware, furlers, Navtec integral cylinders
- Over 40 years experience!

**Call about Carbon Spars.**  
Masts • Booms • Poles

[www.ballengerspars.com](http://www.ballengerspars.com)

831/763-1196

831/763-1198 (fax)

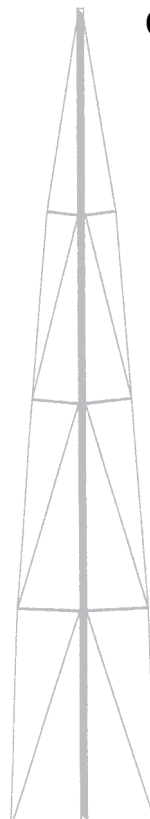

# TO BASH OR NOT TO BASH —

"**B**efore going cruising I focused on all the preparations for the trip south. I don't think I gave more than a token nod to the return trip," recalls Kevin Belcastro of the San Francisco-based Tanton 43 *Toucan*. "Now, I think — no, I know — that deciding how to get the boat home is one of the most important

dodger 30 feet aft of the bow."

The 'bible' on the subject of bashing is the *Baja Bash* by Jim Elfers, who's now harbormaster of Puerto Los Cabos Marina in Baja. He discusses varying strategies and gives detailed info on everything from preparation to emergency anchorages.

The biggest question on the minds of most potential bashers tends to be about timing. From our experience, these days — when the only thing truly predictable about world weather seems to be its unpredictability — there is no longer an ideal time of year to make the trip north. The most important factor in experiencing a relatively easy trip is finding an ideal weather window.

Given the fact that the prevailing winds are usually — but not always — out of the northwest, and the current is always southbound, it would seem that only a fool or a masochist would head north blindly without a game plan. But as you'll read here, strategies differ.

Harry Hazzard of the San Diego-based Beneteau Idylle 15.50 *Distant Drum* explains, "I've always contended that traveling north is a bash, only if you make it so. Going out there and getting yourself beat up just so you'll have something to write and/or complain about isn't quite my cup of tea. I believe that picking your weather windows and places to pull in is a bit smarter. After stopping at Cabo for fuel and/or provisions, our trips in past years have taken as long as twelve days, and have been as short as five."

Ken Roper of the San Pedro-based Finn Flyer 31 *Harrier* is one of the most respected offshore sailors we know — and we're not just saying that because he's a retired brigadier general, or because even at age 82 he could certainly kick our ass. His boat has an engine, but his strategy is all about maximizing time under sail: "I've returned in *Harrier* ten times from various ports in Pacific Mexico. The technique I have settled on can be accomplished by adhering to the following rules: 1) Never get within 20 miles of the coast after dark. 2) Sail on the most favored tack. That is, that tack that takes you most directly to the north. 3) Never forget Rule One.

"Starting from the south, i.e. Cabo, sailing into the prevailing NW wind will take you westerly or even a bit southwesterly. The favored tack in this loca-

tion would immediately run you into land, so it can't be used until you get offshore. When you get out far enough, you can go to a port tack and head northerly for a while. But remember and abide by Rule One! There are areas where your boat can be set easterly by currents and put you on the beach if you're not careful.

*The most important factor in experiencing a relatively easy trip is finding an ideal weather window.*

"I have found that even though the prevailing northwesterlies will set you somewhat south at the beginning of your return, they will begin to lift you above a westerly course as you get farther offshore, after which you'll probably be able to flip to a port tack and get some northing. Of course, since the coast lies in a SE to NW direction, you'll close on the beach on any northerly course, so don't forget Rule One!

"And if you're really lucky, a NW course spinnaker run would be a great way to do the miles between Cabo and San Diego! I'm afraid I have not experi-



BOB JOHNSON

**Bashing home doesn't have to be all misery. After all, it's more time out on the ocean, and who knows, you might even catch dinner.**

issues to address before sailing south."

Hundreds of sailboats travel to the sunny latitudes of Mexico and Central America each year, and while some cruise on to the Caribbean or South Pacific, the majority of these southbounders are eventually faced with the predicament of how to get their boat back to their home waters safely.

There are a variety of options to choose from including: motorsailing up the coast, sailing a modified Clipper Route (to the west initially to catch helpful prevailing winds, hiring a delivery crew to sail her home, trucking (or trailering) her home, or shipping her aboard a specially outfitted freighter. Each option has its pros and cons, so the decision is often a tricky one, requiring boat owners to compare the wear and tear, time, and cost that each option would entail.

## Sailing Her Home Yourself

The most common method is to sail her home yourself, perhaps due to the apparent logic that, "I sailed her down here, I guess I'll have to sail her back up."

The problem, of course, is that the powerful winds and tall seas that most of us revel in as they drive us south can be something less than fun going north. This recollection by Richard Owens of the Sausalito-based Norseman 535 *Meredith* vividly illustrates our point: "By the time we passed Cedros going inside, the wind increased to 38 knots. Some hours later, we had blue water coming over our hard

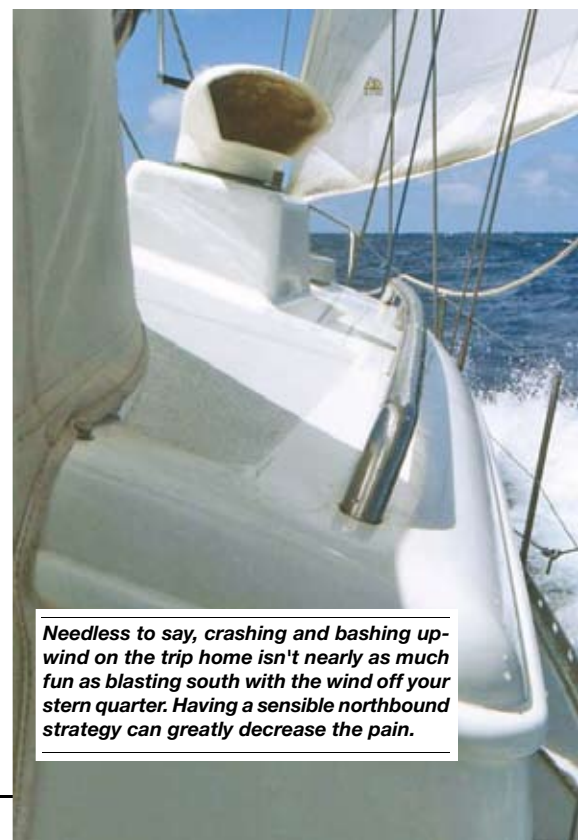

**Needless to say, crashing and bashing upwind on the trip home isn't nearly as much fun as blasting south with the wind off your stern quarter. Having a sensible northbound strategy can greatly decrease the pain.**



# STRATEGIES FOR GETTING HER HOME

enced such a return, but one can always dream."

Believe it or not, sometimes you can get a southerly for a period of hours or even days. As Jean Gregory of the ironically named Islander 36 *Southwind* recalls, "After all we had been through we experienced the wonder of wonders: Reaching to Cedros Island the wind shifted and we actually set the spinnaker and headed north, up-island and aimed at the rhumbline for the north end of the Sacramento Reef."

Jean's general advice for bashing is, "Have patience, patience and more patience." She says when a favorable weather window is approaching, "I always leave, or try to leave, at least 6 to 10 hours before the window. Doing this may give you a few hours of the nasties, but you are leaving refreshed and the calm afterward allows you to rest and enjoy the hum of your engine while tweaking the main to get as much speed as possible (maybe 3 knots)."

Additionally, she advises: "1) Make sure your crew has an open time schedule. 2) Expect the unexpected. And 3) bring enough beer to last at least two weeks in an anchorage."

Ask any 10 sailors a question, and you're likely to get 10 different answers. Bashing strategies are no exception. For example, here's David Addleman's approach: "I've done many Baja Bashes. Some much calmer, some much more brutal. Whatever the conditions, I just hunker down and go as fast as possible."

"I don't listen to the nets or the so-called weather forecasts. They just don't apply at the capes where it matters the most. I do download GRIBs and surface charts twice a day to watch for serious weather. I pretty much rhumbline it from cape to cape all the way up, moving inside about 30 miles south of each



COURTESY PAUL MARTSON

**For coastal cruising, trailerable folding tris like Paul Martson's 'Sally Lightfoot' have some distinct advantages.**

singlehands — but hey, it's gotten him home safely. Most sailors prefer not to bash solo, and some carry more crew than normal.

"We took two extra crew aboard, for a total of four of us aboard," recalls Harold Miller of the Alameda-based C&C 39 *Sea Bear*. "This was the *best* decision I made the entire trip, as we could then do three-hour watches, with nine hours off between. When the going got rough, being well rested made a world of difference."

Having accurate weather info can also help minimize the pain of going north. In addition to downloading GRIB files, "We used the SSB radio to monitor Sonrisanet and Don's Baja Weather, two very good weather resources in Baja that cover the Pacific and Sea of Cortez sides of Baja," writes Bob Johnson of the Berkeley-based Tayana 37 *Charisma*.

"We subscribed to *WeatherRouting.com* and they guided us along," writes Bruce Crockard of the Long Beach-based Beneteau 473 *Tribute*. "It's expensive (\$60/call), but in our book well worth it!" There are other excellent weather sources also, such as Commanders' Weather (which updates the Baja Ha-Ha Rally Committee) and *Buoyweather.com*.

When you're bashing up the coast and conditions get extremely uncomfortable, it's often wise to pull in somewhere to minimize damage to the boat and crew. Elfers' *Baja Bash* comes in handy. "We didn't follow all of his advice," writes John Cogan of the Ventura-based Hylas 49 *Old Moon*, "but his book is right on in terms of strategy and great places to duck into when the weather doesn't cooperate."



COURTESY JOHN CAHILL

**John Cahill has done 10 Baja Bashes. How does he pass the time? Catching up on the sailing news in 'Latitude' of course.**

cape. I don't anchor waiting for weather. I always go out and try. I've only retreated back behind a cape a couple of times, but sometimes I slow down so as to round capes in the middle of the night rather than in the afternoon.

"I strip the decks clear of everything, tape shut the hatches and ports, sky the unneeded halyards, and stow stuff on the cabin sole instead of in the ends of the boat." (Addleman is now sailing his Santa Cruz 50 X in Palau.)

Not many would adopt Addleman's technique — especially since he often



# TO BASH OR NOT TO BASH —

## Via Hawaii

For boats that are homeported in the Pacific Northwest, the idea of bashing all the way up the West Coast is pretty daunting. Unless they choose to truck or ship their boats home (discussed later), sailing home via Hawaii can often be the most painless option, as much of the trip can be off the wind — although it adds thousands of miles and many days to the trip. Randy and Sheri Schneider of the Oregon-based Gozzard 44 MkII *Procyon* considered this option last spring: "This is actually a much easier and safer trip than going all the way to Oregon up the coast." But in the end they opted to bash along the coast, as their insurance company would have required a third crew plus an \$800 surcharge. (See Jimmy Cornell's *World Cruising Routes* for an extensive look at going northbound via Hawaii.)

Another approach that's a lot more fun is to do a circuit out to French Polynesia, then up to Hawaii and home. A variation on that theme — if your boat's



**Keeping an eye out for sea life — like this orca, found north of Turtle Bay — can break up the monotony of a Baja Bash.**

not too big — would be to ship from the islands to San Diego via a PASHA Hawaii Transport roll-on, roll-off cargo vessel.

## Using a Delivery Crew

Nels Torberson is a tough old salt who's done more Ha-Ha rallies than we can count aboard his vintage Morgan Out-Island 41 *Bronco*, and he won his class on all attempts but his first. Still, even old salts sometimes see the wisdom

of having 'hired guns' do the dirty work. "I was lazy and spoiled after a season of warmth," writes Nels. "I didn't look forward to singlehanded the boat back to San Francisco, so I worked out a deal with a friend who sometimes does deliveries and also had a crew.

"He picked up the boat in Mazatlan and had it back in San Francisco in less than three weeks. Although I have to admit he didn't treat the boat quite as I would have, it is a long trip into wind and waves, and some wear is to be expected. Overall I would definitely ask him again."

Nels' experience notwithstanding, the subject of hiring delivery crews is a touchy one that inspires a wide variety of cautions. "For every story I've heard of a delivery captain dealing with unreasonable owners and boats in horrible condition, I've also heard a story of damage done to the boat by an irresponsible crew," writes Kevin of *Toucan*.

Both times that Nancy DeMauro sailed *Cat's Meow* to Mexico she used

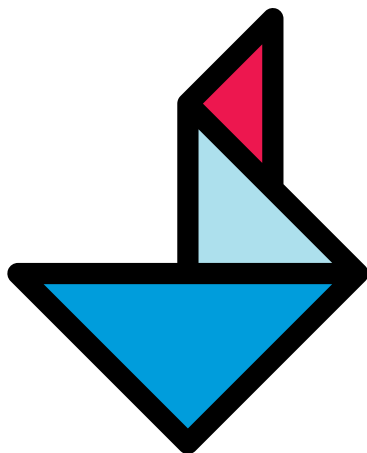

**SAN FRANCISCO  
BOATWORKS**

San Francisco's boatyard | [sfboatworks.com](http://sfboatworks.com)

Marine parts and supplies



Complete haul and repair



Engine repair and service



**Contact us for seasonal  
discounts & special offers**

Authorized dealer for:

**YANMAR**

**marine services  
for power & sail**

415.626.3275

[info@sfboatworks.com](mailto:info@sfboatworks.com)

835 Terry Francois St.

San Francisco, CA 94158



# STRATEGIES FOR GETTING HER HOME

delivery crews to bring her Catalina 36 home to South Beach YC. "I wish I could say it was a pleasant experience both times, but I can't." In one instance when she received the boat, "The interior looked as if they had taken a water hose and sprayed down the inside. There was nothing that wasn't soaked, including inside cabinets."

These are some of the tips she now gives to others:

- Pay by the mile.
- Put a tracker and a satellite phone on board (turned on).
- Make the contract very clear, including who is to pay for damage to the boat. I would include major damage as well as cleaning fees if need be.

Professional delivery skipper Rory Kremer has brought nearly two dozen boats home to California from the Sea of Cortez. He agrees with many of Nancy's suggestions, and also advises:

- Interview wisely; get references and check them. There are

recreational sailors out there who exaggerate their experience. Hire a skipper who can do underway repairs, especially engine repairs.

*Susan French and Tom Rowe hired a delivery crew, and met their Jeanneau 46 'Bateau Frowe' at Ensenada's Marina Coral.*



SUSAN FRENCH

• Agree in writing (email contracts are binding), to the parameters of the delivery, such as rate of pay. The average for this run is \$150 per day for the skipper and \$100 per day for each paid crew member, depending on the size of the vessel. Vessel owners are usually responsible for associated airfares, all provisions, fuel, dock fees en route, and basic repairs which might be purchased while en route. Usually, the skipper is sent with a small amount of petty cash for use in an emergency, or for purchase of additional fuel.

• Once a skipper is contracted, do an inventory of the boat's equipment. Confirm that all equipment is functional. Take photos of the vessel and equipment.

• Once the boat has been delivered safely back to the destination port, review the inventory with the delivery skipper to confirm that all on the vessel is intact. And do a debriefing on needed repairs or damage

## SAL'S

INFLATABLE SERVICES, INC.

### THIS COULD SAVE YOUR LIFE!

Pac Cup  
SSS TransPac



Reserve Now!

### LIFERAFT TRAINING

Just \$39

(\$1,500-2,000 repacking charge if you use your own raft!)

Wednesday, March 7  
St. Francis Yacht Club Docks

- 3:30 Raft Preview/Instruction
- 4:00 Raft Launch & Inflation
- 4:00-5:00 Boarding Practice/Q&A
- 5:00 Showers
- 6:00 Latitude 38 Crew Party at Golden Gate Yacht Club

*There is no substitute for practice!*

PHONE (510) 522-1824 • FAX (510) 522-1064

1914 Stanford Street, Alameda, CA 94501  
salsinflatables@sbcglobal.net • www.salsinflatableservices.com

Reservations  
Required!

# TO BASH OR NOT TO BASH —

incurred during the voyage.

"Overall, it's important for owners to keep Murphy's Law in mind in regard to a long beat like this. If something can go wrong, it will. Carry spare parts as well

from Mexico is to plop it onto a trailer and drive it up the highway. But, of course, few cruising boats are small enough to use this method. Still, if you're shopping

next weekend!

"Driving the Baja Highway 1 was no picnic, though. The road surface is generally good, but the road width can be an issue: 8' 6" is the max width I would haul on that road. Even so, the driver needs to be absolutely attentive at all times. We had no issues, but took many precautions such as carrying extra spares, a grease gun, and extra fuel. And we did no night driving."

The more common means of trucking a boat north is to haul her at San Carlos, which lies about midway up the Sea of Cortez on the mainland side, and let professional truckers deliver her to your home waters in a two-step process (explained below). In addition to eliminating predictable wear and tear from hundreds of miles of upwind sailing, this method saves owners loads of time, as they do not need to accompany the delivery — or even stick around to help drop the mast.

Russ Cooper had his C&C 37 *Liberty* trucked home to San Francisco last spring: "Our haulout, mast pull and load



MATT DANIEL

**Although Mexican roads can sometimes feel as lumpy as the ocean, it was relatively easy to drive 'Tumbleweed' home to Seattle.**

as extra fuel and drinking water. And confirm the good working status of all safety and communications gear."

### Trucking Her Home

The fastest way to bring a boat north

for a boat specifically to do a season of near-coastal cruising, this advantage is worth keeping in mind. Consider Matt Daniel's experience bringing his folding F-31 trimaran home to Seattle last year. "I made arrangements to have a friend drive the empty trailer to Cabo where we were able to haul out ourselves. I was sailing in my home waters of Seattle the

SAN DIEGO'S



**KONA KAI**  
MARINA



Closest Marina  
in San Diego to  
the Open Ocean

- Slips Available from 30-ft to 200-ft
- Liveaboard slip fee \$100 monthly for the first year
- Kona Kai Club Family Membership Discount with 1-year lease
- Phone & Cable TV hook-up, free wifi
- Free pumpout



*Guest slips available*

**www.konakaimarina.com**  
**(619) 224-7547**

OPEQUIMAR

MARINE CENTER  CENTRO MARINO

Our Experience Makes the Difference



High velocity pump fuel dock, 46 gals./min. • Travelift: 88 tons, 100' length, 23' beam  
Dry storage for vessels up to 300' • VHF radio ch. 68 • 24-hour security • Dock rentals  
Sales & rent of used & new boats • Full service boatyard • Do-it-yourselfers welcome

**The Most Complete Marine Center Open 365 Days**  
**Puerto Vallarta, Jal. Mexico / Tel: (322) 221-1800**  
**www.opequimar.com / info@opequimar.com**



# STRATEGIES FOR GETTING HER HOME

dates were all scheduled weeks in advance, and happened on the appointed day with no problem. Because Mexican carriers are not allowed to run over U.S. highways, the boat was set down in Tucson two days after leaving San Carlos, then later picked up by a U.S. carrier for the run to the Bay Area.

"Marina Seca at San Carlos is not the only option to truck your boat, but they've been doing it a long time and have the drill down. Overall, our experience trucking the boat was a good one and we'd do it again."

It's important to note that the system Russ refers to is ideally suited to boats under 30 tons with beams narrower than 13 feet. Fatter boats (up to 16 feet) can be hauled, but the cost rises dramatically, as an escort vehicle is required. Deep-keel boats (more than 7-foot draft) can also present problems, not only because of the depth of the marina, but, as Russ explains: "Ideally, overall height from the bottom of the keel to the highest point on deck — usually the pulpit — should



RUSS COOPER

**Purpose-built hydraulic-lift trucks are key to the well-run boat hauling operation at San Carlos' Marina Seca in the Sea of Cortez.**

be under 13 feet."

Marina Seca Transport uses specialized "air ride suspension hydraulic trailers" equipped with hydraulic arms that can adjust to any hull shape. If your stateside hauler has a similar rig, rather than a standard boat cradle, you'll save hundreds of dollars in crane charges. Marina Seca will quote you a package

price or à la carte, if you want to select your own U.S. or Canadian hauler.

Russ offers one final word of advice: "U.S. Customs will likely make a mess of your boat below decks. They will open compartments, access hatches, etc., and won't put anything back. Make it easy for them to access those areas to the extent you can — a challenge since all your cruising gear from above decks will be stowed below."

## Shipping Her Home

The final option, shipping your boat on the deck of a specially equipped freighter, is the most costly — roughly double the cost of trucking — but has some distinct advantages. The first is that you don't have to pull the mast, and another is that with any luck when you receive her she'll be in exactly the same shape as when you dropped her off for loading.

Dockwise Transport has long been the biggest name in this market, but sadly, they dropped their Mexico-to-British



**UPWIND,  
DOWNWIND,  
STARTING,  
FINISHING...  
DOYLE LEADS!**

Call for a  
race-winning  
quote today.

Stratis, Fiberlay, Crosscut and more. Doyle's unmatched racing technology is dedicated to one simple goal — winning!



**DOYLE SAN FRANCISCO**  
Bill Colombo 510-523-9411  
**NEW DOYLE S. CALIFORNIA**  
Bob Kettenhofen 949-645-5388  
[www.doylesails.com](http://www.doylesails.com)

# TO BASH OR NOT TO BASH

Columbia routes last spring. However, Yacht Path offers a similar northbound service with stops at Panama; Golfito, Costa Rica; Manzanillo, La Paz and Ensenada, Mexico; and Victoria or Vancouver, Canada.

Unlike Dockwise, which uses specially built ships with submersible decks for loading, Yacht Path's vessels can carry sailboats and motoryachts well over 100 feet on deck in (Lloyds certified) steel cradles. A trip from Mexico to Victoria typically takes six to eight days. As you can imagine, it's a complicated business to organize, and we're not surprised that the biggest complaints we've heard about either Yacht Path or Dockwise concern schedule delays.

After cruising Mexico, Bill Thompson and Claudia Cowan took an unusual approach to getting their Mason 33 *Sabbatical* back to her Long Beach home port. "Although we live in Southern California, we found it was nearly as cheap to ship



**After weighing their options, Bill Thompson and Claudia Cowan shipped 'Sabbatical' all the way to Victoria on a Yacht Path vessel.**

*Sabbatical* from La Paz to Victoria, BC as it would have been to ship it from La Paz to Ensenada. So we decided to extend our cruise into the Northwest.

"Our boat was transferred from La Paz to Victoria in June 2010, which allowed

us to cruise Desolation Sound and Princess Louisa Inlet before returning to work in September. We left the boat in BC over the winter and will return to it this summer for more Northwest cruising.

"They delivered the boat in good order with no damage beyond a few scuffs where the tie-down straps crossed the toerail. The best part was that we were able to have two cruising seasons — winter in Mexico and summer in British Columbia — during the same year off from work."

So there you have it, a full menu of options for getting your beloved boat back home safely. We suggest you weigh each method carefully before deciding on your own game plan.

Then again, you could also make the less common choice: Shun all these northbound options and continue around the world instead!

— *latitude/andy*

License #OE32738

## TWIN RIVERS MARINE INSURANCE AGENCY, INC.

"Your Boat Insurance Specialists"

7 Marina Plaza • Antioch, CA 94509  
At The Antioch Marina



### Worldwide Coverage

- West Coast
- East Coast
- Atlantic
- Pacific
- Mexico
- Caribbean

Representing...



Shop Your Renewal & Save • Flexible Survey Requirements

Insurance made simple, affordable and effective.

Broad Navigational Areas • Liveaboards

Years of unbeatable experience to match your needs to the right product.

Agreed Value Policies • Fuel Spill Liability

[www.BoatInsuranceOnly.com](http://www.BoatInsuranceOnly.com) • (800) 259-5701

## PARK PRESIDIO MARINE

Since 1963

Sales • Service • Parts • Accessories  
Factory Trained and Certified Technicians

Your Authorized Bay Area Dealer



YAMAHA



Inflatables • Outboard Motors

1300-A 25th Street, San Francisco

(415) 821-2628

[www.parkpresidiomarine.com](http://www.parkpresidiomarine.com)



40' – \$336/mo!

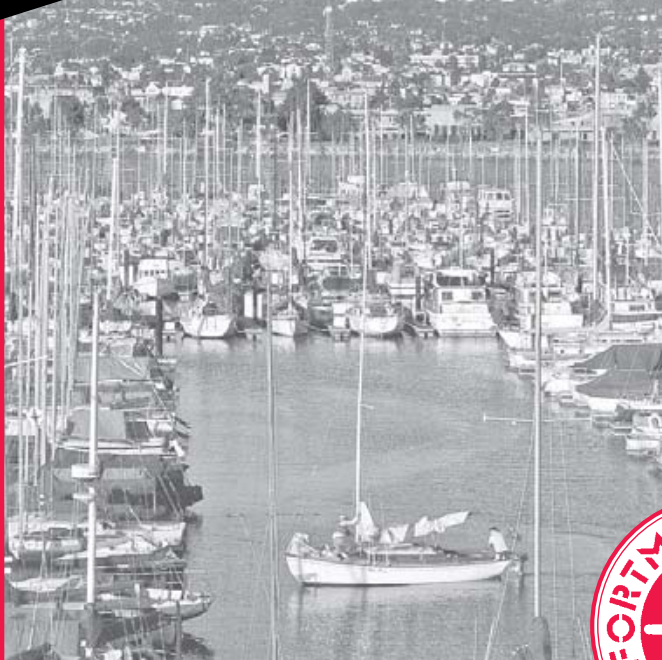

*Come for the summer – stay for the year!*



## **ALWAYS WANTED A GREAT SUMMER HOME?**

- Best Rates
- Idyllic Location
- Well Protected
- Relaxed Community

*Call or stop in –  
You'll like what you see!*

**(510) 522-9080**

**www.fortman.com**



**VALLEJO  
MARINA**



*Gateway to the Bay & Delta*

### **The North Bay's Only Full-Service Marina!**

- Slips starting at \$6.79 per foot!
- Concrete and Wood docks
- 23' enclosed storage units available
- Night security guard



**(707) 648-4370** • Fax (707) 648-4660

**42 Harbor Way • Vallejo, CA 94590**

**www.ci.vallejo.ca.us** marina@ci.vallejo.ca.us

**Cruise **RO**Water.**  
and power  
A Cruising Equipment Company for Real Cruisers™

**Want to Go Cruising, Not Camping?**

**You can with our  
SeaMaker Simple Watermaker.**

20 gallons per hour for only \$3,700

**Go Now and Go Simple!**

Info@CruiseROWater.com

**www.CruiseROWater.com**

# A WHALE

Over the course of three days around New Year's, cruisers in Mexico reported spotting four whales entangled in drift nets. Three of those whales — including a mother and her calf — were saved, but help came too late for the fourth.

Vince Radice of Sonoran Sport Center in San Carlos has seen far too many entangled whales, and has taken part in a number of rescues. "I think it's all too likely that cruisers will come across this kind of situation," Radice says. "If they do, and they're not comfortable attempting a rescue, they should call the Mexican Navy on channel 16 to wait for help." In the video noted below, Radice goes over what he keeps in his whale rescue kit. But he'd like to see such incidents eliminated entirely.

"Those of us who work in conservation have tried to hold the government responsible for their failures in preventing irresponsible fishermen and inspectors from creating this mess," he said.

While we think the heroic saviors in the two rescues reported in this article were acting selflessly, we — and they — can't recommend that others follow their examples. Approaching a 40-ft, 40-ton animal in distress is not only dangerous, it could easily be fatal.

— **latitude** /ladonna

*From Frank Downey, crew aboard the Vancouver B.C.-based Norseman 447 Wendaway:*

On December 31, I was crewing for Mark Schneider aboard *Wendaway*, as was Mary Campbell. We were motoring southwest from Isla Isabela toward San Blas when we spotted some whale spouts about a mile away. But we noticed a bright yellow object near the splashing so we altered course. We were sickened by what we found.

A mother humpback whale and her

**Vince Radice has saved several whales in Mexico. Scan the QR code with your phone, or go to [worldsaquarium.com/blog/female-sperm-whale-calf-rescue](http://worldsaquarium.com/blog/female-sperm-whale-calf-rescue) to watch his latest rescue.**

calf were ensnared in a huge drift net. The yellow object was a plastic 10-liter fuel can that had been tied to the drift net as a marker and a float. The whales were bound tightly together and festooned with yellow rope, red floats and an aqua-colored net. They were swimming northward at about five knots, so we motored along next to them on a parallel course stationed about 150 feet away.

We could see even from a distance that they were in serious trouble. The net covered them tightly from their snouts to behind their dorsal fins. It was apparent to us that if the nets were not removed they would eventually die. They could not swim freely nor could they open their mouths to feed. We had a brief crew meeting to discuss a rescue attempt and agreed unanimously that these magnificent animals were in mortal distress and that we could not leave without attempting to free them.

As skipper of the vessel, Mark maintained his right to call off the attempt if he thought it was too dangerous to continue. Mary volunteered to be responsible for handling the dinghy and I had the job of cutting the net. We donned our PFDs and loaded the dinghy with the ditch bag, the handheld VHF and three folding knives.

We lowered the dinghy into the water and approached the whales from the mother's side, so she wouldn't panic that we were attacking her baby. I was extremely nervous. My mind was filled with concerns about being charged by the whales, having the dinghy capsize, getting caught in the net, or accidentally being struck by an enormous tail or pectoral fin that was literally the size of our dinghy.

Mary raised the outboard out of the water to keep it from being entangled in the net and she began to row toward the mother whale, all the while speaking comforting words to the whales. Upon reflection, I realize the effect that Mary's soothing voice had in calming my own fears. I also believe that the whales heard our voices and, while not being able to understand our words, they may

have sensed our intentions.

Mary rowed us forward of the dorsal fin and we bumped the bow of the dinghy against the body of one of the largest animals on earth. I leaned over the bow, grabbed a handful of net and started cutting. Ensnared along with the whales were numerous dead and dying fish. These fish were bound tightly



to the back and sides of the mother whale. It was a sad and gruesome sight that I will never forget.

As I cut, I began pulling on the net and working our way forward toward the snout of the mother. We had to be really careful, even though the mother was swimming along on the surface and seemed to be cooperating with our efforts. Mary and I were awed by the sound of their breathing. When they exhaled, their breath coming out of their blow holes made a loud whistling roaring sound that reminded us of the enormous size and power of these animals.

Mary kept the bow of the dinghy against the whale and I pulled and cut net as fast as possible. The mother would occasionally submerge to a depth of about six feet. When we sensed she was going down, we had to make sure we weren't tangled up in the net and Mary would row away as fast as possible. We had a few close calls. Occasionally, my hands or fingers would become ensnared and I would be briefly in danger of losing a digit or being pulled out of the boat. I was very afraid.

After about 45 minutes of hard work, we had made our way forward of the







**Michael Robertson spent hours trying to free an entangled whale but ultimately had to leave it. With his and Windy's guidance, the crew of 'The Rose' finished the job the next morning.**

blowhole to the bumps on the mother's snout. As we approached her snout, we could see close up these large conical bumps about two inches high and two inches in diameter at the base. These bumps were terribly ensnared with the net and were bleeding where the monofilament line had cut into the whale's flesh. It looked really painful. I carefully reached down and lifted the net away from the bumps, in order to cut the line without causing further damage to the whale's skin. I had read about whales and I knew that they were warm-blooded animals, but touching the warm, smooth skin of that magnificent creature somehow seemed to calm my fear and possibly made the whale feel more comfortable with our presence.

About this time, a small *panga* arrived on the scene with two fishermen aboard, and they immediately began to help. After another 20 minutes or so, we noticed that the mother and her calf were able to swim slightly apart. The mother whale began to dive and we had to back away really quickly. The fishermen backed off with us and we watched to see if the whales would reappear near us.

They did! The mother and her calf were now able to swim separately but they still stayed close together. The fish-

ermen decided to leave at this point.

Several amazing changes began to occur in the whales' behavior. The calf's snout was heavily wrapped with net, as was the mother's, and at one point it seemed to be showing us its snout.

The mother was almost net-free at this point, and we felt if we could get the net off her snout she had a good chance to survive. There was a lot of the yellow polypro line wrapped around her mouth so I concentrated on that. I pulled as much of it as I could to the surface and cut it into three-foot pieces. I continued in this fashion and eventually was able to clear her snout. The net then began to slide back on her body and disappear behind her. At this point the mother dove and stayed submerged for some time. When she returned she was completely free of the net! We were all so excited that we shouted and cheered.

Mary began to row us back toward the whales. We tried to approach them from the mother's side so we wouldn't spook her but as we got closer an amazing thing happened. Instead of

protecting her calf, the mother maneuvered herself so the calf was on the same side as the dinghy. We looked down and could see the mother below the calf supporting it with her body. She was holding up her baby so we could have better access. She was actually helping us to free her calf!

With the mother in this position, we were forced to position the dinghy directly over the mother's back. If she surfaced, we'd capsize. But her behavior didn't seem threatening so we moved in. We'd gained enough experience cutting the net by then and were confident enough the whales meant us no harm. I went right to work on the calf's snout.

The calf's situation was still pretty serious. The net still enshrouded most of its body and was wrapped tightly around its mouth. As I cut the ropes closer and closer to the whale's mouth, it seemed to relax a little and I was able to begin working some rope out of its mouth. Occasionally the calf seemed to become irritated and would try to submerge. Because the mother was directly under the calf, it couldn't submerge without thrashing around a little. It would seem to struggle for a few moments, the mother would go deeper and the calf would sink. We would row away a little and wait to see what would happen. Every time, the calf would reappear at the surface with the mother supporting it. When the calf was back in position we would row back and get to work. During one of these episodes, the calf's pectoral fin struck the hard bottom of our rigid inflatable dinghy. The sound it made was terrifying.

Eventually the snout came free and I started working my way toward the tail. As I cut net toward the dorsal fin, the en-

**Watch Frank Downey and Mary Campbell, and the crew of a panga, rescue a mother and her calf at [vimeo.com/34811494](https://vimeo.com/34811494) or scan the code.**



WINDY ROBERTSON

MARK SCHNEIDER

# A WHALE

tire net loosened and began to slide back along the calf's body. When it was clear of the dorsal fin, the calf sensed that it was almost free and both it and the mother dove. We were ecstatic about our apparent progress but were not entirely certain we'd cleared all the netting.

By this time we had been at it for about three hours and Mark asked us to return to the boat. We climbed aboard, tired but optimistic that we had succeeded. The boat was about 200 feet from the whales and, as they sounded, we saw they were completely net-free.

*From Michael Robertson aboard the Washington D.C.-based Fuji 40 Del Viento:*

On New Year's Day, my wife, Windy, woke up at 0330, cranked the Yanmar, raised the anchor, and started us on our passage for that day: 52 nautical miles along the Pacific coast of Mexico, from Chacala to an offshore island called Isla Isabela. Late in the day, and nearly to Isla Isabela, I spotted the body of a whale, just 50 yards in front of us.

We saw that it was alive and entangled

in a drift net — a tangle of weighted polypropylene lines, monofilament, and buoys. The whale was hogtied by the netting, lines stretched taut from snout to fluke, with one pectoral fin partially immobilized. Because of this, it couldn't raise its tail and struggled to raise its head. Most of the time, all that was above the water was the smooth, round top of its body, the part between the blow hole and hump.

I got into our dinghy with a knife and headed over to see what I could do while Windy stood off with our two young daughters. In about 45 minutes, I was able to cut away nearly all of the netting and buoys that trailed behind the animal, piling it high in our 11-ft inflatable. But this did little to improve the whale's situation, so I returned the dinghy to *Del Viento* and swam over to the whale.

In the water with the whale, I felt small and vulnerable. The smooth top of its body was now above my head. Treading water about 10 feet away from

a wounded wild animal, I felt scared and stupid. I inched closer.

Curiously, when the whale blew, it sounded like the threatening noise of a big cat. Not the roar of a lion, but the noise Hollywood dubs in when a tiger is cornered. It wasn't a reassuring noise and startled me every time. When my head was underwater, I heard a cacophony of high-pitched squeaks.

Putting my mask in the water was surreal, seeing all that was down there, the size of a city bus, next to me. I let the swells move me closer until I bumped up against it, just abeam of its hump. The body felt firm and the skin slippery. I quickly began stroking it hoping that would help the whale distinguish friend from foe. Then I grabbed a polypropylene line about 18 inches down and cut it. My pulse raced and I felt jittery from adrenaline.

With my life vest on, I couldn't dive far below the surface. Even with fins on, I struggled to control myself in the surge of the two- to three-foot swells. At one point, my fin snagged in the mono-

## McDERMOTT COSTA

insurance brokers - est. 1938

### Commercial Operations

- COMMERCIAL POLICIES  
Marinas, Yards, Yacht Clubs, Brokers, Shipwrights

### Pleasure Yachting

- YACHT & BOAT POLICIES  
Offshore, Coastal, Inland and Liveaboards



Lic. #OB21939

Bill Fowler

McDERMOTT COSTA INSURANCE  
(510) 957-2012 Fax (510) 357-3230  
bfowler@mcdermottcosta.com



## KISSINGER CANVAS

Marine Canvas & Interiors

STEVEN KISSINGER

(925) 825-6734

Covering the Entire Bay Area



- Biminis
- Boat Covers
- Cushions
- Sail Covers
- Headliners
- Awnings

### DODGERS

Side handrails and window covers included.

### OPTIONS

Aft handrail, dodger cover, sailing bimini.

Free Estimates and Delivery



filament and pulled at my leg with the surge. I thrust my leg away in a panic. I put the knife back in my pocket and removed my vest, looping it through just one arm and letting it drag behind me. I could now get a bit deeper, but not down to the fluke, about 12 feet below the surface. I swam this way to the front of the



SARA JOHNSON

whale. Line and netting were wrapped around its snout and on the pectoral fin on its side. This fin was white and about the size of a surfboard, an old longboard, and also covered in barnacles. I recalled the power exerted by the whales we'd seen a few days prior, slapping these giant fins repeatedly against the water. I opened my knife, dove underwater, and reached for some netting at the tip of the fin and started cutting quickly.

I was startled when the whale abruptly moved the fin out of my reach. I backed away and swam towards the head for the first time. Before I realized it, I was staring at a blue-gray, human-like eye

***The Johnson family discovered this dead whale entangled in netting while sailing to Isla Isabela aboard their Benford 38 'Wondertime'.***

the size of an orange.

My head at this time was filled with fears, both rational and irrational, compounding my anxiety. What if he moves, and I get tangled in this mess and drown? What if I dive down and successfully cut something heavy, and get tangled and pulled down with it? Meanwhile, seas were making the operation difficult in addition to the other risks.

Up near the head, this time on the

leeward side, I again met the animal's gaze about a foot underwater. I could see that this pectoral fin was not as tangled, but did have a single polypropylene line passing underneath it, pulling taut from the snout. It was about four feet underwater. I dove down to cut it, but the line was pressed against the body and the fin moved and spooked me. I was at an odd angle in the water, struggling with the life vest wrapped around my good arm. I would have been more effective with it off completely, but I didn't think that was the right thing to do. I swam forward and again dove to cut a single line that I thought might make a difference, if I could reach it. But then this massive head bowed down even lower and underneath me. I was over the top of it and could feel my body pushed around by the current created by the whale's movement.

I'd had enough. I wasn't physically spent, and I even figured I could keep

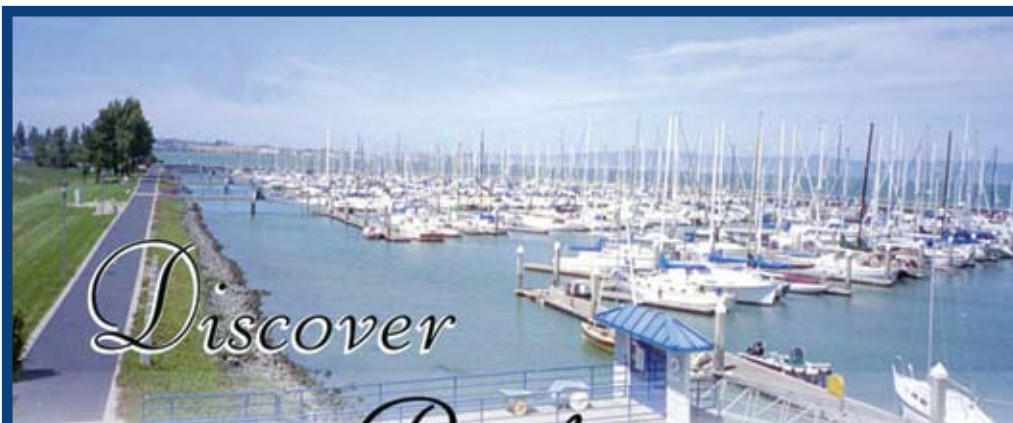

Discover

Brisbane  
Marina



**GREAT LOCATION!** Just minutes to Central Bay sailing.

**GREAT RATES!** Starting at \$6.02/foot!

**MARINA GREEN** with picnic/BBQ areas, Bay Trail Access and FREE Wi-Fi.

**HOME OF THE  
SIERRA POINT YACHT CLUB**



From Hwy 101, take the Sierra Point Pkwy exit and follow the signs to the marina.

**400 Sierra Point Parkway  
Brisbane, CA 94005**

[www.ci.brisbane.ca.us](http://www.ci.brisbane.ca.us)

**(650) 583-6975**

[harbormaster@ci.brisbane.ca.us](mailto:harbormaster@ci.brisbane.ca.us)

# A WHALE

my fear in check long enough to make some real improvement to the situation, but I felt it wasn't wise. I wanted to help this suffering mammal, but I couldn't accept the risks.

It was difficult to motor away, but we felt there was nothing more we could do. We could see it continue to blow as we got farther away. We both were uneasy and troubled.

Once anchored at Isla Isabela, we contacted the other boats about the situation. *The Rose* was game for giving it a shot so I got aboard their boat to find the whale, using the track on our iPad and anticipating a southerly drift. We didn't find it.

That night, Windy studied the iPad track more closely and realized that the drift had to be northerly, even though this was contrary to the wind and swells. The next morning, *The Rose* headed out again using this new information. They found the whale in less than an hour. Its blows were weak and gurgling.

John jumped in with the whale to cut netting and his crewmember, Saskia, stood by in the dinghy near him, ready



***YouTube is filled with inspiring videos of whale rescues. Just think twice before attempting a rescue of your own — these creatures are as powerful as they are beautiful.***

to assist. After a couple of hours, John was tired and cold, but making progress. Underwater he heard the same squeaking I heard and felt the same fear that I felt. But he knew he didn't have much time left and he finally got angry. He said he felt like one of those doctors on TV who begin screaming at their ER patients, "You will not die on me, man,

not on my watch!" Something clicked and he became resigned to whatever might happen, pushed his trepidation aside, and went for it. John began swimming deep, underneath the belly of the whale, at least 15 feet below the surface. He would cut what he could, surface, and dive again, over and over. He was all over the whale, in front of it, beneath it, and on top of it.

At this time, crew from another boat nearby, *Three Hour Tour*, jumped into the water to assist John. Shortly after this, they cut the last taut lines, the netting fell away, and the tired whale swam along the surface before sounding.

Whoops and hollers of joy sounded over the VHF's of the four boats out there. Windy said she felt a tremendous emotional load lifted.

It occurred to me later that all 15 crew aboard *Boomer*, *Del Viento*, *The Rose*, and *Three Hour Tour* can rest easy knowing that, for the rest of our lives, no matter where we are, we never have to spend a dime on one of those whale-watching tour boat trips.

**New Member Showers and Laundry Facilities Now Open!**

# Emeryville Marina

ON THE BAY

**NEW SLIPS!**  
Now taking reservations for 40' to 60'

When you call Emeryville Marina Home...  
...call this your backyard!

**Free Wi-Fi and Video Surveillance**

Slips from 20-65 ft  
Full Amenities - including  
Fuel Dock & Pumpout Station

**(510) 654-3716**  
[www.emeryvillemarina.com](http://www.emeryvillemarina.com)

**MARINAS International**



**need glasses to read?**

**The Floater**

Floats in the most turbulent conditions

Frame options: Tortoise Shell, Carbon Fiber & Grey  
 Lens options: Polarized, Polarized Reader, Polarized  
 Photo chromic and Polarized Prescriptions available.



**the Straddie**

Polarized with non-polarized magnification  
 Lens options: Grey or Amber  
 +1.50, +2.00, +2.50



Barz Optics Australia  
 Burleigh Heads, Qld  
[www.barzoptics.com](http://www.barzoptics.com)  
 61 755764365  
[kevin@barzoptics.com](mailto:kevin@barzoptics.com)

**Barz Optics**  
[www.barzoptics.com](http://www.barzoptics.com)

Barz Optics USA  
 Murrays • Carpinteria, CA  
[www.murrays.com](http://www.murrays.com)  
 1-800-786-7245  
[steve@murrays.com](mailto:steve@murrays.com)

CHECK OUT OUR NEW FLOATER MODELS AT STRICTLY SAIL PACIFIC APRIL 12-15 • WIN \$300 VALUE OF SUNGLASSES PER DAY AT THE SHOW!



MARINE INSURANCE SPECIALISTS

*Your best source for Yacht and Boat Insurance  
 tailored to your needs and competitively priced*

**We Insure:**

Sail or Power ♦ Classic or Contemporary  
 Fiberglass ♦ Aluminum ♦ Steel ♦ Wood

At Heritage Marine Insurance you will find knowledgeable  
 insurance professionals who provide superior service  
 and the finest coverage available today.

To be sure you're getting the best insurance value  
 please contact us for a quote.

[www.heritagemarineinsurance.com](http://www.heritagemarineinsurance.com)

**800-959-3047**

Fax 860-572-5919

[classics@heritagemarineinsurance.com](mailto:classics@heritagemarineinsurance.com)

Program available exclusively through:



## Captain's License

Maritime  Institute

### Captain's License Training

Maritime Institute has a course Near You!  
 From *San Rafael* to *San Diego*  
 or *On-line* at your own pace

- ✓ OUPV up to 100 GT
- ✓ Able Seaman
- ✓ Radar and Radar Renewal
- ✓ FCC License Exam - MROP  
 Marine Radio Operator Permit

**Toll Free: 888-262-8020**

[www.MaritimeInstitute.com](http://www.MaritimeInstitute.com)

# SOUTH PACIFIC CRUISING STRATEGIES —

**W**e've always found it curious that most North American sailors will spend years preparing for a dream trip to the South Pacific, but once they finally get started they'll race all the way to New Zealand or Australia in a single season.

From the West Coast to Australia is an enormous distance — almost 8,000 miles — and it's also a paradise for those who enjoy warm weather, clear water, varied cultures, and great safe cruising. With those things in mind, we knew we didn't want to rush through. So by the time my wife Sherry and I passed through the Panama Canal aboard our CSY 44 *Soggy Paws* in September of '08, we'd done lots of research and planning, which has served us well ever since. We intend to spend five or more years in the Pacific.

There are at least four popular route options for cruising boats crossing to French Polynesia from the Americas. Each has advantages and disadvantages, and each requires different timing. Here are those that we considered:

1) Take the most well-traveled route directly to the Marquesas from any Pacific port in the U.S. or Central America.

2) Sail to the Galapagos, on the equator, then take the direct route to the Marquesas.

3) After the Galapagos, sail south to Easter Island, and perhaps Pitcairn Island, entering French Polynesia via the Gambier Islands. Then sail north to the Tuamotus and Marquesas.

4) Sail south to visit Peru and/or Chile. Then, the following season, leave from any of the South American ports directly to Easter Island and continue on as in option 3 above.

**Not many cruisers stop at Pitcairn Island, home to descendants of the HMS *Bounty* mutineers. Those who do, find it fascinating.**



## The South Pacific Milk Run

By far the most commonly traveled route is the first leg of the so-called Pacific Milk Run to the Marquesas. It's roughly 3,000 nm, depending on where you start from, and is typically mostly a broad reach or downwind. The best time for crossing on this route is March-April, so you arrive in the Marquesas near the end of the southern cyclone season. For most, this route will cross the equator and the Inter Tropical Convergence Zone

*It's a paradise for those who enjoy warm weather, clear water, varied cultures, and great safe cruising.*

(ITCZ), where many boats experience calm or unsettled weather.

Once south of the ITCZ, the sail will be in mostly E-SE trade winds. Of course it's important to note that there are no possible stops along the way to break up the trip. Once in French Polynesia, three island groups are normally visited: the Marquesas, the Tuamotus and finally the Societies (Tahiti and her sister islands).

## Via The Galapagos

A crossing to the Marquesas from the Galapagos, which lie about 500 miles west of Ecuador right on the equator, is also about 3,000 nm. However, you will cross the ITCZ between Panama and the Galapagos before heading west.

If you want to spend some time in those unique islands — which inspired Darwin's theory of evolution — be sure to check out the current immigration regulations before leaving the mainland. (See our website below for a description of our stay in the Galapagos from January to March 2010.)

Departure timing and the rest of the Milk Run comments in option 1 above apply here also. In addition to the obvious advantage of seeing the unique animal life of the Galapagos, stopping there potentially al-



ALL PHOTOS DAVE & SHERRY McCAMPBELL

lows for repair work, crew changes, and re-provisioning.

## Via Easter Island & Pitcairn

The sail from the Galapagos south to Easter Island (27°S 109°W) is about 2,000 nm and mostly a beam reach. Because this trip takes you well south of the trade wind belt, it should be done earlier than the Milk Run in order to take advantage of the more settled weather during the southern summer. Our research indicates that January and February are good months to leave the Galapagos for this trip.

Once at Easter Island, it is about 1,100 miles to Pitcairn Island (famous as the hideaway of the *HMS Bounty* mutineers), then another 300 miles to the Gambiers. All three stops offer unique experiences. By the time you reach the Tuamotus, in April, cyclone season will be nearly over. If you have planned ahead and obtained a Long Stay Visa for French Polynesia, you'll be able to take your time seeing French Polynesia, with many cruising options. With our Long



# AN OCEAN FULL OF OPTIONS



**Spread:** 'Soggy Paws' lies at anchor at Isla Isabela in the Galapagos, ready to head west into the South Pacific. **Insets:** Sherry with a huge Gambier oyster; Dave gives his bananas a bath to wash off any critters.

Stay Visa we were able to spend our full six months in the Gambiers, Tuamotus and Marquesas. By doing this eastern part of French Polynesia backward from the normal Milk Run route, we avoided the crowded anchorages. This route also positioned us for an easy sail to Hawaii in late September/early October for the upcoming southern cyclone season. (More on this later.)

## Via Peru and/or Chile

For those who sail down to Peru or Chile first, it makes sense to leave from any port in western South America and sail directly to Easter Island. If leaving from Chile, the normal route is to stop in the Juan Fernandez Islands, 600 miles out (where Scottish sailor Alexander Selkirk was marooned in the early 1700s, apparently inspiring Daniel Defoe's novel *Robinson Crusoe*).

This area normally has southeast trades, so it will be a broad reach or downwind run. From Lima, Peru, the distance is only about 2,000 miles, but this route sometimes crosses the high pressure area that sits north and east of Easter Island, and you might find lighter winds.

Once south of about 22°S, you are no longer in the trade winds. The most settled weather is in the southern summer, January to March, so that is the best time to make this trip. The remaining comments in option 3 above apply.

## Wintering in Hawaii

Even with a six-month Long Stay Visa we felt somewhat rushed to visit the Gambiers, Tuamotus and Marquesas, especially with the superb scuba diving we found in the Tuamotus. So we delayed our progress west by "wintering over" in Hawaii during the southern cyclone season.

From the Marquesas, the last island group we visited, it is an easy 2,000-nm, mostly beam or broad reach, northwest to Hawaii. We had a near-perfect passage with 12-15 knots of wind and light seas all the way, and an easy ITCZ crossing (late September and early October). Of the 500 boats that crossed the Pacific in 2010, we know of about ten that chose to go to Hawaii for the winter. About half of those left from the Marquesas and half from the Societies. The farther east you can get for your departure north, the easier the trip will be due to the wind angle advantage.

On the return to French Polynesia we left at the end of April from Oahu and had a somewhat rough, windy passage for the first week, close-hauled, with winds in the 18- to 22-knot range. After that it settled down and we had a pleasant passage through the ITCZ and during the last two weeks. As with any long passage, timing and good weather information is essential. And it helps to have someone watching the ITCZ for you too.

## The Second Year

We arrived in the Western Tuamotus in mid-May. Then, after a month or so, worked our way southwest with the rest of the Milk Runners to Tahiti for the annual Puddle Jump crossing celebration called the Tahiti-Moorea Sailing Rendezvous. Its activities are very worthwhile as an introduction to South Pacific culture.

Afterwards we still had four months to get to Tonga before the start of the southern cyclone season. So we meandered behind the crowds through the Societies, Cooks, Samoas and on to Tonga. We arrived just as the rest of the

**For Dave and Sherry, exploring the underwater realms of the islands they visit adds immeasurably to the richness of their travels.**





# SOUTH PACIFIC CRUISING STRATEGIES —



SHERRY McCAMPBELL

**As evidenced by this photo from the *Tuamotus*, French Polynesian kids are among the friendliest you're likely to meet anywhere.**

cruisers were leaving for the 1,200-mile crossing south to New Zealand. This can be a dangerous crossing, which must be done again coming north the next year.

For us, the next few weeks involved securing our boat for the two months we would be on vacation back in the U.S. November and December are officially at the start of the southern cyclone season, but because Tonga rarely experiences cyclones then, it was a good time for us to be away from the boat. We used a strong mooring maintained by some former cruisers at Tapana (The Moorings' anchorage 11 on the charts), south of the main harbor at Neiafu, Vava'u. There are also a number of strong moorings available right inside Neiafu harbor.

There are many reasons for taking more than one season to see French Polynesia. Not all are obvious until you've been here for a while and have talked to some of the many international cruisers who have spent multiple years here and in the western Pacific. At present, very few Americans spend more than three months in French Polynesia and only a few take more than six months to cross the Pacific to New Zealand or Australia during their first year. After that the normal Milk Run brings cruisers from New Zealand back north to Fiji or Tonga, then all the way to Australia at the end of their second southern cruising season.

The major reasons most cruisers don't take longer are cyclone seasons and immigration issues. But in some cases it is just poor prior planning. For others it is the rush to get west for one reason or another. And then there are those that just want to stay with their Milk Run buddies.

## Wintering Over

Options for avoiding the southern storm season and delaying your progress farther west include: staying in any place within 8° of the equator or anywhere north of it, hauling out at a cyclone-protected boatyard, and tying to a strong mooring in a protected

storm anchorage.

Cyclone season cruising destinations across the Pacific include such places as Hawaii, the Line Islands, Kiribati Islands, the Gilberts, the Marshalls, Micronesia, New Zealand, the Solomons, and Papua New Guinea. In French Polynesia there are a number of good places to haul out (some where they will bury your keel in the sand), including Apataki in the Tuamotus, and Tahiti and Raiatea in the Societies. Farther west, both Tonga (Vava'u) and Fiji (Savusavu/Buda Point) have strong storm moorings in well-protected hurricane holes.

## The Western Pacific

From French Polynesia westward to Australia the distances between stops are much shorter, and there are many options for things to see and do. You'll find island groups on both sides of the equator, and thus the opportunity exists to cruise north and south to avoid the cy-

clone/typhoon seasons. Since the trade winds generally flow from the northeast north of the equator and from the southeast south of the equator, moving north and south within about 20° of the equator is relatively easy. It is only when you want to go back east that things get more difficult, although not impossible.

Here's an example of what is possible during a multiple-year Pacific cruise. We're currently in Tonga. In our third year we plan to visit Fiji during the southern winter cruising season, starting in May, then move north to the Mar-

*Only a few Americans take more than six months to cross the Pacific.*

shalls in October to avoid the southern cyclone season.

In our fourth year we'll remain in the Marshalls over the northern winter and summer for the diving season — as you might have guessed, we love scuba diving. Once the northwestern Pacific typhoon season has died down, probably in January, we'll move west through the Federated States of Micronesia just south of 10° N to Palau. We'll remain in Palau through the northern summer and most of the following winter. In March we'll use the Northwest Monsoon to cruise southeast to New Guinea, the Solomon Islands and the relative safety of the equator. (See chartlet.)

The following year in May, during the southern winter cruising season,

## SOUTH PACIFIC RESOURCES

There are many worthwhile resources on cruising the South Pacific. These are some favorites:

• *Charlie's Charts of Polynesia* by Charles and Margo Wood, updated 2007. Very detailed guide covering most islands from Easter and Hawaii to 165 west.

• *Guide to Navigation and Tourism in French Polynesia* by Bonnette and Deschamps, 1999. This hardbound book has nice color pictures and chartlets with good navigation and ashore information, but only covers selected popular islands.

• *Exploring the Marquesas Islands* by Joe Russell, 2000. This small but excellent guide has lots of detailed info for both ashore and navigation, with exceptionally detailed chartlets.

• *The French Polynesia Dive Guide* by Kurt Amsler, 2000. Nice glossy dive guide to 27 selected scuba sites mostly in the Societies. Features 3D dive site maps with many photos.

• *Landfalls of Paradise* by Earl Hinz, 1999

• *South Pacific Anchorages* by Warwick Clay, 2nd ed, 2001

• *The Pacific Crossing Guide* – RCCPF/OCC, 2nd ed, 2003

• *Sailingbird's Guide to the Kingdom of Tonga* by Charles Paul, 1st ed, 2004

• *Moon and Lonely Planet Guides*

• *Soggy Paws' Compendiums* by Sherry McCampbell, 2011. Separate Internet documents cover the Marquesas, Tuamotus, Societies and Hawaii. Each is an extensive island-by-island summary of all the information available on the Internet from cruisers' websites, blogs and forums. Included are references to guide book coverage when available, detailed information on weather forecasting, weather sources, a current estimator and advice for atoll passes, and the best scuba sites. They may be downloaded free at: <http://svsoggypaws.com/files>

— dave & sherry



# AN OCEAN FULL OF OPTIONS

we'll continue south, then west, through Vanuatu and New Caledonia to Australia.

## Major Cruising Issues

Below are three of the more difficult issues you must deal with when deciding how to cross the eastern Pacific through French Polynesia:

**Immigration** — Unless you obtained a Long Stay Visa prior to arrival, French Polynesia allows U.S. citizens to stay only 90 days in a six-month period, although the boat can stay for a year. No exceptions. (For Long Stay details see: [www.pacificpuddlejumps.com/longstayvisa.html](http://www.pacificpuddlejumps.com/longstayvisa.html))

Keep up to date on the regulations at Jimmy Cornell's website, [www.noonsite.com](http://www.noonsite.com). EU citizens are allowed to stay in French Polynesia for two years without having to do any extra paperwork.

**Tropical Storms** — Storm seasons drive timing for a safe cruise across the Pacific. Warm water and air enhance

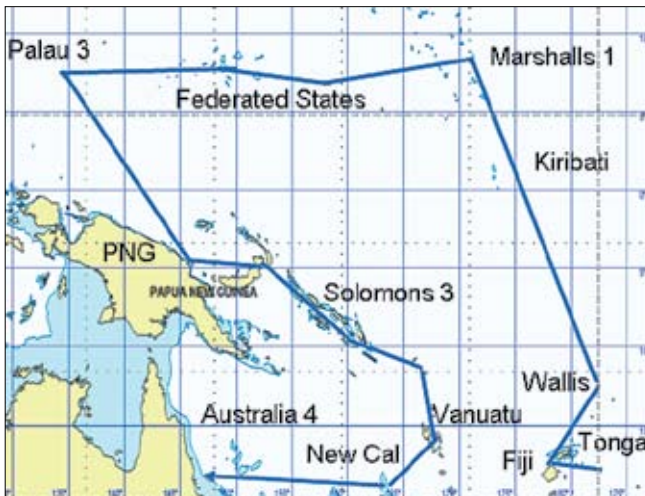

**What's the rush? Rather than making a beeline for 'Oz', Sherry and Dave plan to visit many parts of the Pacific over five years.**

storm formation; therefore summer is storm season in both hemispheres. El Niño years allow warm water, and therefore storms, to move farther east. Cyclone season in the southwest Pacific, including most of French Polynesia, is November to May. Hurricane season along the Central American coast is June to November. Typhoon season in

the western North Pacific is June to November, but there can be typhoons any month. Only the area within about 8° either side of the equator is a relatively safe zone.

**The ITCZ** — The Inter Tropical Convergence Zone (ITCZ), not to be confused with the SPCZ further southwest, is an area of frequent thunderstorms and squalls of variable magnitude, within about 10° of the equator. Crossing it safely involves careful boat preparation, timing, and good access to weather resources.

**W**e hope some of you reading this will consider planning a multiple-year visit to the South and Western Pacific. We think you'll find this vast and beautiful area to be one of the highlights of any 'round-the-world voyage.

— dave mccampbell

To study details of Dave and Sherry's cruising plans, along with chartlets, see: [www.svsoggypaws.com](http://www.svsoggypaws.com).



## INSURING YACHTS FOR OVER 50 YEARS

Providing Cruisers and Racers All Over the World  
with Prompt, Reliable Service since 1959

Contact Us for a Quote



Exclusive  
**MARINERS Odyssey®** Program

- Mexico
- South America
- South Pacific
- Caribbean
- Mediterranean

**Racing Sailboat Program**

- TransPac
- Pacific Cup
- PV / Cabo Races
- Caribbean Regattas

**Seattle**  
800-823-2798

**N. California**  
[boomeins@aol.com](mailto:boomeins@aol.com)  
800-853-6504

**L.A./Orange Co.**  
800-992-4443

**San Diego**  
800-639-0002

**Puerto Vallarta**  
52-322-297-6440

**East Coast**  
**Bradenton, FL**  
800-914-9928

**www.marinersins.com**

**QUALITY COVERAGE AVAILABLE IN MEXICO**

Mariners Insurance Mexico offers insurance programs for health, homes, autos, motorcycles and yachts in Mexico.

**www.marinersmexico.com**

Corporate Office: 206 Riverside Ave., Suite A, Newport Beach, CA 92663 / Ins. Lic. #0D36887



# AMERICA'S CUP 34

With just 18 months to go before what most local sailors hope will be the Finals of the 34th America's Cup on San Francisco Bay, we thought we'd reset the scene with an Insider's Guide. After all, it's been confusing because of the new format, the many changes, and the potentially game-changing variables that have yet to be fully resolved.

The biggest possible game-changer to what will likely be the wildest sailing event in history, given the yet-unfinished and unsailed 72-ft cats with 40-knot potential, is that it might not even happen on San Francisco Bay.

The assumption has always been that the America's Cup Finals will be held on the Bay, and that there will be many changes on the San Francisco waterfront to accommodate these events. But as we said when the San Francisco venue was first announced, it provides a once-in-a-lifetime opportunity for any number of petty bureaucrats and/or activist groups, be they serious or merely The Friends of Bedbugs and Mosquitoes, a chance to throw a wrench into the works and/or even keep it from happening.

Yes, it's true that in December the San Francisco Planning Commission voted unanimously to certify the Environmental Impact Report for the '13 America's Cup. But that was just a start, because now more than a dozen agencies need to consider the issues within their jurisdictions before the event can get final approval. And then there are the various activist and environmental groups. Despite the widespread cooperation from many environmental groups, a few have complained that the "final"

EIR did not sufficiently detail the scope of mitigation programs, and does not guarantee the sources of funding under certain scenarios.

It's hard to know which group's objections are genuine, and which, if any, are motivated

primarily by a desire to derail the Cup. But the one thing we know from going to Berkeley in the '60s, and from page 18 of our autographed copy of Saul Alinsky's *How to Screw Up Anything*, is that an effective strategy is to vocally

support some cause you really oppose, but then complain that you can't support it because it doesn't go far enough. As in, "The America's Cup's guarantee to build a waterfront so clean you can eat off the ground is an encouraging start, but just doesn't go far enough in cleaning up the area." Or, "Yes, we believe the Cup will create jobs, but until every person in San Francisco can be guaranteed a 20-hour-a-week job that will allow him/her/unsure to afford a new house, a new car, and luxurious retirement at age 40, the jobs just aren't adequate."

After the Planning Commission's approval, the groups had 20 days to file an appeal. Alas, we had to write this before any group decided whether to appeal. If they did appeal, the Board would then have 30 days to take action. The combination of the appeal and response periods means that the Board of Supes would have to take action in or before early February. The Board could approve the FEIR, or request modifications before eventually voting to uphold the FEIR, while a settlement could also be agreed between the parties before or after the Board takes up the matter.

Experts say that such back-and-forth on certifications and appeals is not unusual in the California Environmental Quality Act process, and does not mean a lawsuit is imminent. And the language of the various members of the coalition asking for delay is not entirely hostile. "I think it will be approved in a timely fashion," Jon Golinger, president of the Telegraph Hill Dwellers, told the *San*



groups can take the matter to court. As we remember from the 33rd America's Cup, once the matter hits the courts, there is no telling what might happen or how many delays there might be. Given all the work that needs to be done on the San Francisco waterfront for the Cup,

and how little time there is to get it done, it's not out of the question that the Cup will have to be postponed or moved to another venue.

While a cloud of uncertainty would not be welcome, even if a lawsuit did result, it does not necessarily mean a court would issue an injunction preventing the event from

going forward. More likely, the length of the process and the uncertainty of the outcome would prompt negotiation. If we understand the word 'negotiation' in this context, it's French for being bought off with a sufficient amount of money. But

## REALITY CHECK

We think many objections to the Cup on the Bay have been motivated by a fervent desire to strike out at the Filthy Rich. The FR are conveniently personified by Oracle's Larry Ellison, estimated by some to be the third wealthiest American with a net worth of something like \$33 billion. That got us musing about how much Larry really cares about the America's Cup.

It's total speculation, but at age 67, and having already won the America's Cup once, we imagine Ellison probably cares most about are: 1) his family; 2) his health; 3) Oracle; 4) his many residences. After that, we're not sure what. Maybe his jets.

The way we see it, Larry hired Russell Coutts, at many millions of dollars a year, to be his paladin to 'take care' of the America's Cup. But he, Larry, doesn't have that much of his personal wealth or passion invested in it. As a result, we don't think he loses a minute's sleep worrying about whether or not the America's Cup will be held on San Francisco Bay. You'll remember that Ellison made a bid to buy the Golden State Warriors last year, and could have easily outbid anyone by billions. But when it reached a certain price — peanuts to Ellison — he simply lost interest. We think he's probably got the same attitude toward the America's Cup on San Francisco Bay. If it's not going to cost too much in terms of money and annoyances, fine. But if it becomes a pain, he'll just have Coutts and crew take it elsewhere. So if anyone thinks they are making Ellison's life miserable by all the objections, it's our opinion that they're mistaken.

*Francisco Chronicle*. "Other projects have come in with a high-handed manner. That was not the case here. We're mostly happy." Cross fingers.

But if the Board doesn't take action that satisfies the activist groups, the



# — INSIDER'S GUIDE



**One of the goals of racing the AC45s in the World Series is to teach the crews how to sail wing-sail boats before graduating to the big girls.**

about 50% more than it does in the United States.

Among those left standing include Artemis from Sweden, the Challenger of Record ever since the Club Nautico di Roma's Mascalzone Latino dropped out. This Swedish syndicate is being headlined by Marin native and St. Francis YC member Paul Cayard. For previous America's Cups, Cayard has famously been an Italian, a San Diegan, a San Franciscan, and we're not sure what else. It's not that Cayard is a man without a country (or region), it's just the way the America's Cup game is played.

There's also the strong Emirates Team New Zealand. The United Arab Emirates (UAE), a federation of seven sheikdoms on the Persian Gulf and in the Gulf of Oman, was never known for sailing tradition or skill, but then they bought New Zealand, moved it to eastern Arabia, and have become contenders. Or it could be that the largest airline in the Middle East, Emirates, is Team New Zealand's primary sponsor. One of the two.

The two French teams are Aleph and Energy Team. Despite their many attempts, beginning with Baron Marcel Bich, who brought lots of disposable Bic pens and 12 Meters to America, the French have never done well in the America's Cup. They excel in exotic singlehanded events and setting round-the-world records in giant multihulls.

There's also a Chinese team, which delights us no end, as it's our belief that the Communists have boycotted this 'worker's event' for far too long.

Team Korea, which has also sailed under the name White Tiger, gives hope that the Bay Area will finally see a better class of Korean BBQ and kimchi. And lastly, there is Green Comm from Barcelona, Spain, and the Lombardy region of Italy, which will be flying the flag of 'Spitaly' and

*It's hard to tell but Larry Ellison was delighted to go for a spin aboard an AC45 with Jimmy Spithill.*

that's probably just the cynic in us.

In any event, the uncertainty gives hope to Newport, Rhode Island, which would love to have the America's Cup back. But other venues might battle for it, too. If we were betting sailors, we'd say there's a 60% chance the event will be held on San Francisco Bay, 20% in Newport, and 20% in Italy. For what it's worth, Ellison bought a big mansion in Newport, and despite a blip in the stock price of Oracle Corporation, could afford to buy all of Italy, particularly now that it's on sale.

## WHO'S INVOLVED

Oracle Racing was to be the default Defender. But in December, a North Carolina entity called African Diaspora Maritime Corporation, headed by unnotable sailor Charles Kithcart, filed suit against the Golden Gate YC, saying ADM should be allowed to compete to be the Defender. ADM was previously last heard from — and only briefly — in '95 when they announced they were thinking of being a participant in the San Diego America's Cup. This time around ADM has asked the Supreme Court of the State of New

York to force GGYC not only to accept their application and hold a Defender Series, but also to provide the group with at least two 45-ft catamarans and pay damages in excess of \$1 million.

"We believe the lawsuit was late, lacking and lamentable," responded GGYC Vice Commodore Tom Ehman in a burst of alliteration. If the lawsuit gains any traction, we also expect a similar lawsuit from something probably to be called Occupy the America's Cup. But unless Diaspora and Occupy win their court decision and get money to start their own defense challenges, there will be one America's Cup Defender, and that will be Oracle.

As best we can tell, there have been a total of 14 real or imagined Challengers. Six have gone down the drain. Three of these were apparently too shaky to ever want to identify themselves. There were two others from Italy, a country which has severe financial problems. And one from Australia, where everything costs



GUILAIN GRENIER

GUILAIN GRENIER

# AMERICA'S CUP 34

is dedicated to "sustainability." Really.

A third Italian team recently joined the fracas in the rule-bending way that's to be expected with the America's Cup. Patrizio Bertelli of House of Prada fame announced in November that his Luna Rossa team was officially challenging. To make up for lost time, Bertelli hopped on the elevator — the one that goes straight to the penthouse — by way of a deal with Emirates Team New Zealand to share design info. (Ironically, the two teams clashed in the Louis Vuitton Cup Finals for the right to challenge Alinghi in AC32.) This time around, their "cooperation agreement" gives the Italians, among other things, the plans for ETNZ's AC72 design and access to some data. For their trouble, the Kiwis get a sparring partner and more cash to fund their own campaign.

Of course, this being the America's Cup, there was bound to be fighting. Oracle and Artemis asked the International Jury to issue a verdict on the ETNZ/LR deal. The final answer: yes, but with a few restrictions. The bottom line is that the arrangement stands.

LR launched its AC45 last month in Auckland, but since they haven't raced in any ACWS events yet, it remains to be seen how they will fare.

This means that every nation with a significant sailing history will be competing. Well, except for England, Germany, Australia, Denmark, Canada, Singapore, Antigua, and Trinidad & Tobago.

With Oracle defending on behalf of the Golden Gate YC, you might expect that local sailors would be occupying many of the crew positions on the team's AC 45s that have been sailed to date. Alas, to our knowledge only John Kostecki, who came up through the Richmond and St. Francis YCs to international sailing glory, has been on the water on a regular basis. The other Northern California big name is, of course, Paul Cayard, but he's running the Artemis show, although not from the tiller.

rassingly weren't as fast as a lot of other boats, Oracle went nuclear by challenging Alinghi in the 33rd Cup in Valencia with a 90-ft trimaran, the wing mast of which wouldn't have fit beneath the roadbed of the Golden Gate Bridge. The Swiss answered with a 90-ft catamaran. Never had so much money been spent to design and build two boats for what turned out to be just two races. The two multihulls in the 33rd America's Cup were spectacular beasts, but the two-race series wasn't very satisfying.

After winning, Oracle embraced the idea that America's Cup boats should be among the fastest and most exciting boats in the world. The result has been identical 45-ft cats for the America's Cup World Series road show that precedes the big event, and to use as practice vehicles, and the monster 72s that will primarily be used in the Louis Vuitton Cup and the America's Cup Finals.

The idea of competing with a ball of one size in the regular season, and a differently sized ball in the playoffs and Finals is one that has taken the world of sports by storm. Baseball Commissioner

## THE BOATS

After ages of competing for the America's Cup in monohulls that embar-

# LOCH LOMOND MARINA

**Completely Rebuilt Marina • Gas & Diesel Fuel Dock • Free Pump Out Station  
Modern Launch Ramp • Guest Slips Available • Marine Mechanical Boat Repair  
Arena Marine Supply Store • Andy's Local Market • Bait Shop  
Land or Sea Canvas • Windjammer Yacht Sales • Loch Lomond Yacht Club**

**110 Loch Lomond Drive, San Rafael, CA 94901**

**Phone: (415) 454-7228 • Fax: (415) 454-6154**

**www.lochlomondmarina.com**

**Harbor Master – Pat Lopez • pat@lochlomondmarina.com**

**MOVE-IN  
SPECIAL**

★★★★★★★★

**THIRD MONTH**

**FREE!**



# — INSIDER'S GUIDE

Bud Selig has announced that starting next year, Major League Baseball will use oversized yellow softballs for the regular season, saving the familiar hardballs for the World Series. Similarly, the National Basketball Association's David Stern announced that starting next year, the NBA will use

the smaller-sized women's basketballs for the regular series, but revert to the familiar larger balls for the playoffs and Finals.

A lot of traditionalists grouched that the multihulls would be a disaster for the America's Cup, as it would no longer be as tactical a competition, nor would there be as many passing opportunities. But thanks to a tweaking of the courses and the inherent instability of the 45s, this has proved not to be the case. Even the slowest of the teams have found that it's easy to pass the fastest after the opposition's cat has flipped. We don't know how many times the cats



GUILAIN GRENIER

paring the speed and power of the 45s to the 72s is like comparing a go-cart to an Indy car. There are going to be a lot of terrified sailors on the Bay in '13, and lots of underwear that will need de-browning after every race.

As Paul Cayard told sailing journalist Michelle Slade, "It doesn't take a brain surgeon to figure out that the handle-ability of this seriously over-powered boat, which is under-crewed on an extremely short course in the windiest venue in the world — you multiply all that together and you have a shitfight on your hands."

It doesn't help that the 72s will be as complicated as they are big. As Cayard told journalist Kimball Livingston, there are 38 hydraulic cylinders needed to control the 130-ft tall wing sail on the Artemis 72 now under construction. "We want to avoid running hydraulic piping to each of them because that would be heavy, so we have electro-valves embed-

***There will be at least five more World Series races in which the AC 45s will go head-to-head.***

have flipped in racing to date, but there have been enough capsizes to keep folks interested. And in any kind of decent wind, flipping is always a possibility. In previous America's Cups, tactical skills and brute strength were very important for crews. In the 34th Cup, there will be a greater emphasis on big *cojones* and nimble athletic ability.

With the 45s being so edgy in even moderate conditions, the 72s, which are designed to a box rule, are going to be downright scary on windy summer afternoons on San Francisco Bay. Com-

## GET READY FOR SPRING!

# STANDING RIGGING / LIFELINE REPLACEMENT

Visit our Alameda Rig Shop

**For a safe, fast, worry-free summer!**

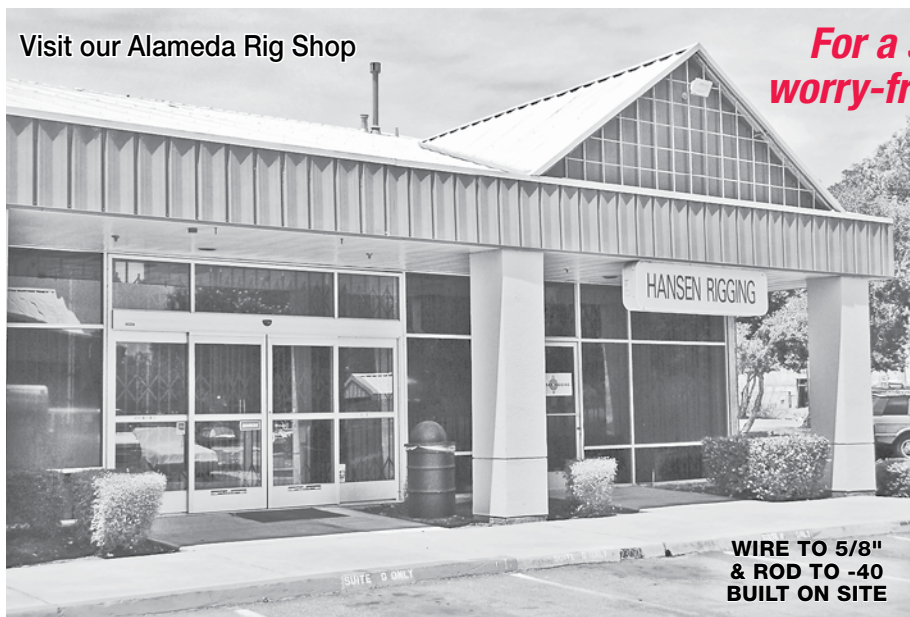

**WIRE TO 5/8" & ROD TO -40 BUILT ON SITE**



## HANSEN RIGGING

2307 Blanding Ave., Alameda

510.521.7027

[www.hansenrigging.com](http://www.hansenrigging.com)

# AMERICA'S CUP 34

ded in the wing to actuate the hydraulics. But if you had two wires, positive and negative, running to each electro-valve, your wing would look like a PG&E substation, and that's heavy, too, so we use a CAN-bus [controlled area network] with far fewer wires. Still, it's incredibly complex."

While the 72s will be launched this year, they apparently won't be used for racing until the summer of '13.

So far there have been three World Series events: Cascais, Portugal, last August; Plymouth, England, in September; and a rather damp San Diego in November. There are currently three events remaining for the '11-'12 season of World Series: April 7-15 in Naples, Italy; May 12-20 in Venice, Italy; and June 23-July 1 in Newport, Rhode Island. If some venue wants to pony up the bucks, other sites could be added. And then it gets really interesting, because the first two scheduled World Series events of the '12-'13 season will be held on San Francisco Bay August 11-19 and August 27-September 2, when there is a good chance the wind will blow hard.

Once the World Series racing is over in '13, everybody gets out of their 45s and into their 72s — assuming each team is actually going to build one. (There are doubts about that.) The Louis Vuitton Cup will be July 4-September 1, 2013. If the Diaspora or Occupy win court cases, there might even be a Defender Series. Don't bet the pink slip to your boat on it. If all goes well, the America's Cup Finals will be held on the Bay September 7-22.

## WHO'S DOING WELL

**W**ho has been kicking ass to date? Well, you've got the Kiwi Emirates, which is no surprise, as Kiwis have had as great an impact on the America's Cup as African Americans have had on basketball. Tied with them in first place in the Overall Fleet Racing Championship is Oracle Racing Spithill, which is also just one point behind the Kiwi Emirates in the overall match racing standings. Emirates is being driven by Dean Barker, a Kiwi. Oracle Spithill is being driven by James Spithill, an Aussie. And Oracle Coutts

has sometimes been driven by Russell Coutts, a Kiwi, and more recently, Simon Daubney, also a Kiwi. See what we mean about the Kiwis?

Down a notch or more for a variety of reasons are Artemis, Team Korea, Energy Team, and Aleph. Consistently at the bottom are China and Green Comm Racing. For the environment, we hope that the 'sustainability' is indeed sustainable.

## THIS JUST IN!

**I**n mid-January, youthful Brit sailing legend Ben Ainslie made a two-part announcement. The first is that he has signed with the Oracle team for the 34th America's Cup. The second is that he'll be putting together his own America's Cup team for the 35th America's Cup, wherever and whenever that might be. But the most controversial aspect of his announcement was that he will be putting together his own team for the rest of the World Series events, then jump ship for the Finals to sail with Oracle.

## WINDEX INNOVATION

### WINDEX<sup>®</sup> 15

**with Bird-Proof Spike!**

**Why Windex 15 is the choice for most sailors:**

- 15" wind vane (38 cm)
- Sapphire suspension bearing
- Adjustable tacking arms with tabs
- Vane and tabs feature reflectors for high visibility day and night.
- Weighs just 3.9 ounces (111 grams)
- Stands 12.75" tall (32 cm)
- Bird-proof spike extends another 10" (24 cm) above vane to discourage birds from landing.



The versatile J-Base can be purchased for Windex 15 to allow top or side mounting.



Contact us for your **FREE** copy of the latest **DAVIS** catalog

**Davis Instruments** 3465 Diablo Ave., Hayward, CA 94545 USA  
 Phone 800-678-3669 • Fax 510-670-0589 • Email info@davisnet.com

**www.davisnet.com**

## Custom Canvas & Interiors



The Gianola Family has been designing and fabricating custom canvas and interiors since 1969. Gianola Canvas Products offers you the best in quality, more choices, and personal service.



**265-B Gate 5 Road**  
**Sausalito, CA 94965**  
**(415) 332-3339**  
[www.gianolacanvas.com](http://www.gianolacanvas.com)



# — INSIDER'S GUIDE

Ben brings some welcome 'bad boy' cred to the America's Cup, as during December's Finn Worlds in Perth, Australia — a really big deal in really small boats — he created quite a ruckus. Feeling that the wake of the press boat had interfered with him, he leapt off his Finn, climbed onto the photoboat, and angrily confronted a cameraman. Officials disqualified him from two races for behavior unbecoming an officer and a gentleman — or something like that — and there went his Worlds. Ainslie hasn't become what John McEnroe was to tennis back in the '80s, but there's hope.

In other news, if bureaucrats and activist groups don't derail the America's Cup on San Francisco Bay, current plans call for the team bases to be to the south of the Bay Bridge, between the bridge and South Beach Harbor. The start/finish line, as well as the big video screens and all the rest, will be at Pier 19.

Under the guise of political correctness, the Private Spectator Yacht Marina, which was to be northwest of the Bay Bridge, has been eliminated. Since this marina was to be for the megayachts owned by

the 1/100th of 1%, it had suddenly become the favorite viewing area of the Bay for a vocal segment of the other 99.99%. Alas, we think it was a 'cut off your nose to spite your face' move because, like or

not, the gathering of dozens of 150- to 250-ft boats would probably be the biggest single attraction of the America's Cup. Bigger than even the racing. It's a guilty pleasure of almost all the aspirational folks to gawk at the trappings of tremendous wealth. And if anyone would be more attracted to the megayachts than the aspirational, it's the progressives, who hate them with every cell in their bodies. Losing the residency of those yachts is going to cost San Francisco a whole lot more money than we think most people realize. And



**Ben Ainslie is bringing his bad self to the Oracle team.**

GILLES MARTIN-RAGET

therefore jobs. But hey, ideological purity is everything. Just ask anyone who has been condemned to live in Cuba for the last 40 years.

With hardly any Americans sailing on the American boats, and with Northern California's perhaps most accomplished sailor running the Swedish team from shore, it's kind of hard to feel a lot of home court pride in the event. And it is a billionaire's game that's hard for most people to identify with. Nonetheless, we support it for the simple reason that we expect it will provide the wildest sailing action the planet has ever seen. It's going to happen somewhere, and the money is going to flow, so why shouldn't it happen and flow on San Francisco Bay?

A lot of sailors we've talked to said they are going to watch the event from their boats, from Angel Island, from Pier 39, this or that yacht club, or what have you. We suppose we'll do some of each of those over a period of weeks. But when it comes to the last races of the Finals, we want to be with the hordes at the AC Village. We hope to see you there.

— **latitude/richard**

## Boating... You Love It, We Know It

**At BoatU.S. Marine Insurance, we know what coverages boaters need for the best protection on the water.**

From our array of low-cost policies, developed for boaters by boaters, to our acclaimed Damage Avoidance Program, coverage from BoatU.S. lets you do what you love with complete peace of mind.

- ▶ Policies for All Boats — Yacht to PWC
- ▶ Diminishing Deductibles
- ▶ Coverage for Fishing and Watersports Equipment
- ▶ 24-7 Claims Service from Boating Experts
- ▶ Flexible Payment Plans

**For a fast, free quote, call  
1-800-283-2883**

mention priority code 4848

**or visit [BoatUS.com/insurance](http://BoatUS.com/insurance)**

Installment fees apply with payment plan. All policies subject to limits and exclusions.



# MAX EBB

It had been a very late night at the office for my entire work group, finishing a major proposal just barely ahead of a tight deadline. And this was followed by an early morning because it had fallen on me to personally drive the package to the client's office in Marin.

I got it there on time, but as I was about to pull onto the freeway to drive home for some badly needed sleep, I remembered that I had one more errand in this neck of the woods: A friend was putting his boat up for sale, and I'd volunteered to drop off the *Classy Classified* ad copy, with photo, at the *Latitude 38* office. The deadline for classified ads was the day before, but I hoped that if I caught them early in the day — and begged and pleaded — I could get the ad in under the wire for next month's issue.

I groped for one of the copies that usually clutter up my back seat, found the address, keyed it into my car's GPS, and a few minutes later I was on a quiet street just off Mill Valley's main drag, in front of an old frame house.

This didn't seem right — I expected the *Latitude 38* editorial office to be a large modern building in the business district with contemporary corporate styling. I double checked the address and looked again at my GPS. This had to be it.

No one answered the doorbell and there was no response to my knocks. The door was open, so I let myself in.

This was the *Latitude 38* World Headquarters, all right. Posters of past covers lined the walls, files and folders covered the desks, computer monitors displayed page layouts and ad copy. File cabinets and shelves filled up every available bit of space, and every horizontal surface was three-deep in papers, folders, magazines and random sailing artifacts.

*This didn't seem right — I expected it to be a large modern building in the business district.*

"They all must be out to lunch," I concluded, noting that it was already a few minutes past noon. So I found the one unobstructed chair in the office and sat down to wait for the staff to return.

A couple of minutes later I became aware of a very faint sound that seemed to be coming from the middle of the building, around a corner just out of

sight. It was a rapid clicking sound, like the sound made by those old IBM PC keyboards. Maybe someone was in the office after all.

I followed the sound to a door and pulled it open. Luckily I didn't just barrel through as I was greeted by a gaping hole. There was a ladder down to the basement level of the house, but it was way too steep to be up to code as a stairway — it was more like the companionway of a large sailboat. I turned around and climbed down, facing the stairs in good nautical form.

The sound became louder, and I followed it past another set of desks, these even more cluttered than the ones upstairs, and then around the last corner to the left. There was one last desk, and one person hard at work at his terminal, typing at high speed.

He looked exactly the way I always imagined a sailing journalist should look: Kind of big and athletic but not at all slender, with reddish hair and a bushy mustache, and a slightly weathered face. He wore shorts and flip-flops, even though it was a cold day in the middle of winter, and a shirt from a Big Boat Series held 10 years ago.

The desk was piled high with sailing magazines from all over the world. There were stacks of race results, photos of top-end race boats, and a large three-speed winch. There was a large broken rudder blade leaning against the opposite wall, and sailbags on the floor.

"Ahoy!" I hailed to get his attention.

The writer glanced over in my direction. "Cone of silence, please," he whispered with a finger in front of his lips. He turned back to his keyboard to finish a paragraph, then swiveled around in his chair to face me.

"Hi, Max," he said. "What brings you down to the dungeon?"

"I just came by to drop off a *Classy Classified* for a friend," I said, a bit sur-

prised that he knew my name since I couldn't recall ever meeting him. Sensing my confusion, he rattled off the name and class of my boat, and how I'd done in the last couple of regattas.

I handed over the folder. "Here's the copy and photo, and the check," I said hopefully.

"Deadline was yesterday, you know. And we are very very strict about the classified deadline. But for you, Max, we can slip it in. Heck, we probably won't start laying it out till next week anyway, so if you promise not to tell anyone I'll sneak it into the middle of



*Believe it or not, this modest little house is where the 'Latitude 38' magic happens.*





# WEIRD SCENES INSIDE THE GOLD MINE

the pile."

"Thank you, thank you!" I blurted, still taking in the perfectly organized mayhem that engulfed the racing desk at *Latitude*.

"You know, you'd do a lot better with that old boat if it had a transom scoop and a new number one," he advised.

"I'm impressed," I said, admitting that a new jib was at the top of my upgrade list. "You must know secret details about every racing sailboat on the Bay."

"You wouldn't believe some of the spooze I deal with," he sighed, leaning back in his chair, blue eyes twinkling. "Look at this one — some wingnut wins a beer can race with his Rub-A-Dub 26 and thinks his boat should have a feature story and a centerfold spread."

"Still," I said, "I have to admire the way

you guys write about the same events year after year, and always manage to make it sound fresh."

"Yeah, it doesn't always come easy," he admitted. "And then there's the travel. You can't write anything worthy about the BVI Spring Regatta, or the Admiral's Cup, or Antigua Race Week unless you go there."

"Hey, somebody has to do it," I reminded him.

"But why me?" he complained, although his overacting gave him away. "I've got more swag than I can use in a lifetime. Here, take one of these little magnetic compasses they were giving out in St. Martin — it slips right onto your watch band."

***As Max made his way deeper into the editorial dungeon, the tapping grew louder . . .***

"Thanks," I said, as I confirmed that the compass really worked. "This is a great little party favor."

"Max, you should take over this job!"

"I couldn't do that," I joked as I dropped the gift into my jacket pocket. "I can tell you love it too much to ever give it up."

He rolled his eyes, but not convincingly. "Okay, here's a more serious proposition: I need one more crew for the race on my boat this weekend — haven't had time to even make the crew calls."

"I thought you sold that thing," I said.

"I repossessed it . . . for the third time!" he said. "It's been a great source of supplemental income, and usually comes back in better condition than when I sell it. Hey, this last time it came back with a new 3DL main and a couple of tape drive headsails. I should sell it more often!"

The crew offer was tempting. A chance to play with the cool kids. But I'd made other plans for the weekend, and more likely than not I'd be called back to the office to prepare supplemental information to add to our big proposal.

"I'll have to pass this time," I said. "But put me on your crew list. And thanks again for getting in my friend's ad."

"Aw, don't mention it," he said as he turned his attention back to his keyboard. "But can you do me a favor and tell Lee, if you see her, to be a little early? We're going to do some practice sets before the race."

"This guy knows everything about everyone," I thought to myself as I agreed to get the message to Lee, if I could.

I loitered for another few seconds to take in the ambiance, marveling that I was inside the very belly of the beast. My eye was drawn to the one photo in this corner of the office that depicted something of great natural beauty other than a sailboat. "Is that your girlfriend?" I asked.

"Max, you are out of touch with popular culture. That's supermodel Heidi Klum; she sailed with us at the Bitter End Yacht Club Pro-Am event."

"You do have it rough," I said to the writer. "Anyway, I should be heading home. Coffee break's over, back on your head!"

He nodded to acknowledge that he got the joke. "Spooze on!"

**I** made my way back up the ladder to the main floor, but nearly tripped over a loose shoelace so I sat down again



PHOTOS LATITUDE / LADONNA

# MAX EBB

in that one empty chair to secure it. I yawned and stretched, aware again of how tired I was after the very short off-watch at home the previous night. Then the door opened and in walked two women from the *Latitude* staff, back from lunch.

"What can we do for you?" one asked.

"Actually I'm all set," I said. "I just stopped by to drop off something with your racing editor downstairs."

"That's odd," she said. "We don't have a racing editor."

"Really?" I said with much surprise. "Then who was I just talking to down there?"

"There's nobody downstairs," she repeated.

"But I just gave him some papers," I insisted.

The two women looked at each other, then looked back at me suspiciously. It wasn't clear if they were more concerned that someone had let himself into the building or that I was losing my mind.

"Let's go down and have a look," one of them suggested.

I followed her down the steep ladder again, past the work stations on the lower level and around the corner to the racing desk. But the desk was clean! There was no computer terminal, and no regatta posters, no sailbags, no

*The desk was clean! No computer, no posters, no three-speed winch, no photo of Heidi Klum.*

three-speed winch, no picture of Heidi Klum. And no folder with the ad copy and photo — the counter I'd just seen the writer put it on was bare.

"That's weird," was all I could manage as we returned to the main floor.

"I guess I must have dozed off while sitting here waiting for you to come back from lunch," I said, pointing lamely to the

chair, "and dreamed the whole thing. My apologies."

Then I tried to explain that I had been up most of the night. But what happened to those papers I'd had with me?

"I'm sure you'll be fine after you get some rest," they assured me as they gently pushed me out the front door.

"So much for getting my friend's ad in for next month," I sighed when my search for the ad copy in the car didn't turn up anything except more old back issues of *Latitude*.

But there's still something I can't figure out. The ad showed up two days later in the online version of the *Classics*, and when the next hard-copy issue came out, there it was. I suppose the folder could have fallen behind the chair, and when the staff found it they didn't know it was submitted late. But my friend said his check never cleared.

And I still can't explain where this little compass on my watch band came from . . .

— max ebb

**We've got the sails you need, to get the results you want.**



**One Design - PHRF - Club Racing**

**Ullman Sausalito**  
415-332-4117  
rsodaro@ullmansanfrancisco.com

**Ullman Newport Beach**  
714-432-1860



**SPECTRA WATERMAKERS™**

**EFFICIENT. POWERFUL.**  
**UNSURPASSED CUSTOMER SERVICE.**

[www.spectrawatermakers.com](http://www.spectrawatermakers.com)

**Mathiesen Marine**

For all of your electronics and electrical needs

Sales & Installation of all major brands of marine electronics



Electrical system Troubleshooting & Repair



PC & Mac based Navigation Systems



Corrosion issues, Inverters, Battery Banks



Visit our showroom located at 3300 Powell Street, Emeryville



(510) 350-6622 [www.MathiesenMarine.com](http://www.MathiesenMarine.com)





# THREE NEW PRODUCT LINES SPECIALLY FORMULATED FOR MARINE USE

**New**

Forespar is proud to introduce three new boat care product lines. Each is specifically formulated to be effective without unnecessarily damaging the fragile marine environment as possible.

## New Boat Friendly Products

### Lanocote Prop and Bottom

Non-Toxic Foul Release Bottom Coating

### MareLube Lubricants

A Complete Family Of Marine Quality Lubricants

### ReFresh Deodorizers

3 New All-Natural Head & Cabin Deodorizers



All Natural Marine Deodorizers

All Natural Foul Release Bottom Coating

MareLube Marine Lubricants

Now Available At Your Local Marine Store

# FORESPAR®

[www.forespar.com](http://www.forespar.com)  
Tel: 949 858-8820

## got survey?

**Terry Tupper**  
NAMS CMS Member  
Bluewater Marine Survey  
(916) 599-5241  
(415) 722-7695



**Jack Mackinnon**  
SAMS AMS Member  
Senior Marine Surveyor  
(510) 276-4351  
(510) 909-6956



## FULL SERVICE MOBILE RIGGING



- Competitive Rates
- More than 18 years experience
- Firm labor quotes on most projects

[yachtcheck@yahoo.com](mailto:yachtcheck@yahoo.com) (510) 815-4420

Want your kids to like sailing?

**LEFT COAST**  
Dart



[www.LeftCoast.biz](http://www.LeftCoast.biz) (408) 340-0352

# THE RACING

January saw a mix of weather conditions for local racing, such as the **RegattaPro/SYC Midwinters**, **EYC's Jack Frost Midwinters** and **CYC's Midwinters**. A West Coast sailor wins the **Rolex Yachtsman of the Year** and the **Volvo** gets weird. And, as usual, **Race Notes**.

## Rolex Yachtspeople of the Year

San Diego's Bill Hardesty, reigning Etchells World Champ, attracted the national spotlight last month when he was named the 2011 Rolex Yachtsman of the Year. Joining Hardesty on the podium is Anna Tunnicliffe of Plantation, Florida, the first woman to be honored with the award four years in a row!

Besides winning the Etchells championship and other major Etchells regattas as skipper, Bill has excelled as tactician over the past year, with diverse and far-flung wins such as the Congressional Cup in Long Beach, the Monsoon Cup in Malaysia, the Portimão Portugal Match Cup, the Stena Match Cup in Sweden, the Open de España Match Race in Spain, and the CMRC Grade 2 Invitational in Chicago.

"This is a huge honor," said Hardesty. "The long list of past winners is very impressive and includes people who I have always considered to be the best in the world. A lot of credit goes to the teams I raced with this past year. Sailing is truly a group effort and winning this award would never have been possible without great teammates: the Etchells World Championship team of Steve Hunt, Mandi Markee and Craig Leweck,



MANDI MARKEE/AMORY ROSS/USSTAG

San Diego's Bill Hardesty and Florida's Anna Tunnicliffe were named the 2011 Rolex Yachtsman and Yachtswoman of the year.

and Team GAC Pindar skippered by Ian Williams."

Anna Tunnicliffe led her women's match racing Team Maclaren (with crew Molly Vandemoer of Stanford and Debbie Capozzi of Bayfield, NY) to an ISAF Sailing World Championship that qualified them for a berth in the Elliott 6m keelboat event at the '12 Olympics. Other winning venues for the team this year include Skandia Sail for Gold in Weymouth, UK, and the Santa Maria

Cup in Annapolis.

The pair will be honored at a luncheon on February 22 at St. Francis YC.

— latitude / chris

## RegattaPro/SYC Winter One Design

Thirty-three boats turned out for the January installment of the RegattaPro/SYC Winter One Design Series (third of four), which featured clear skies and more wind than forecast. With winds hovering around eight knots and steady all day from the northwest, the day's two races were both completed. Sitting just west of the Circle, the venue saw an all-day ebb. The forecast had said the wind would clock from NNW to W and then to SW, so when the breeze began to die off about three-quarters of the way through the first race, the RC began discussions on how to quickly reset for the impending shift. However, just as the last boats were finishing the first race, the pressure built back up, the wind still coming from the northwest.

In the first race, several boats in the J/120 fleet decided to go shrimping at the leeward mark. Remaining fleets managed to fight off the urge, but had issues of their own, such as wraps, slow hoists, and so on. In the second race, everyone had figured out the preferred side of the course, which made the RC a bit nervous over the J/105 start since it had 16 boats on the line. However they were all gentlemen/women and behaved themselves, with Walter Sanford's *Alchemy* executing a textbook start, dead on the line at the gun.

Aside from wanting to put on good races, the RC had to deal with one other challenge: get two good races off, yet get the fleets back in time for the second half of the Niners game. Mission accomplished!

— jeff zarwell

## REGATTAPRO/SAUSALITO YC WINTER ONE DESIGN SERIES STANDINGS (1/14; 6r, 1t)

J/120 — 1) **Grace Dances**, Dick Swanson, 8 points; 2) **Desdemona**, John Wimer, 10; 3) **Chance**, Barry Lewis, 15. (7 boats)

J/105 — 1) **Wonder**, Tom Kennelly, 15 points; 2) **Walloping Swede**, Theresa Brandner, 16; 3) **Wianno**, Ed Walker, 20. (18 boats)

MELGES 24 — 1) **Personal Puff**, Dan Hauserman, 5 points; 2) **Wilco**, Douglas Wilhelm, 11; 3) **Smokin'**, Kevin Clark, 13. (6 boats)

ANTRIM 27 — 1) **Always Friday**, John Liebenberg, 5 points; 2) **Abracadabra**, Ian Chamberlin,



JEFF ZARWELL / REGATTAPRO

10; 3) **E.T.**, Tony English, 14. (4 boats)

Complete results at [www.regattapro.com](http://www.regattapro.com)

## Volvo Ocean Race

The second leg of the Volvo Race — which started 11 editions ago in '73 as the Whitbread Around the World Race — from Cape Town to Abu Dhabi, was one of the weirdest in yacht racing history, all to avoid the pirates of the Arabian Sea. The six entries, with sailors from 15 countries, all competing in Volvo Open 70 V3s, raced to an undisclosed location in the Indian Ocean, where they were loaded onto a ship, taken past the danger area, then dropped off not far from Abu Dhabi to resume racing.

Second leg honors went to Franck 'Multihull' Cammas and his French crew aboard *Groupama*, who are noted primarily for their bold tactical moves. Nearing the finish they rolled Spain's *Team Telefónica*, which nonetheless continues to hold the overall lead. The biggest American personality in the event is New Englander Ken Read, skipper of *PUMA*, making his second Volvo run. While leading in the very early going of the third leg to Sanya, China, *PUMA* is way down in





**Mellow conditions allowed the RegattaPRO fleet to make it back in time for the game.**

points because she lost her mast in an earlier leg. But there are six legs to go before it's all over in Galway, Ireland, in July, and anything can happen.

The Volvo Race has an absolutely terrific website at [www.volvoceanrace.com](http://www.volvoceanrace.com), which is clear and easy to use, but at the same time provides a staggering amount of information for those interested in all the nitty gritty. Well done! And yes, this is the event that San Francisco Bay sailors Paul Cayard and John Kostecki both won a few years ago.

— latitude / richard

**Jack Frost Midwinter Series**

It was a wet and wild day of sailing on January 21 for Round 2 of Encinal YC's Jack Frost Midwinter Series. With breeze in the mid-20s, puffs nearing 30, and a five-knot ebb, it was one of those Midwinter races that had a decidedly summer-like feel. The intimidating conditions on the Central Bay led to only 22 boats taking the start, as several competitors bailed at the last minute, while many never even left the dock. Owing to

the carnage in the first race, most of the fleet never popped a chute in race two, with nearly half the fleet tucking in a reef instead.

In the PHRF 119 and under class, Don Ahrens' Farr 36 *Red Cloud* recovered from a blown jib halyard in the first race to turn in a consistent 3-2 scorecard for the day, claiming the top spot on the score sheet. Tony Pohl's Farr 40 *Twisted* won the first race before Daniel Alvarez's JS9000 *Jet Stream* bounced back from a DNF in race one due to a kite around the keel to take a close win in race two.

In the SF30 class, George Ellison's Schumacher 30 *Shameless* sailed to a pair of wins, increasing his series lead over Scott Christensen's active J/29 *Audacious*. The Wyliecat 30 class saw Steve Wonner's *Uno* trade wins with Dan Benjamin's *Whirlwind*, with the latter claiming top honors of the day. In PHRF 120 to 233, it was Tim Stapleton's well-sailed Cal 2-27 *Ypso* winning

the day, further extending his lead in the overall series standings. With the challenging conditions on the day, only three Santana 22s took the start, with Anna Alderkamp's *Byte Size* trading bullets with Jonathan Andrews' *Bonito*.

— ronnie simpson

**ENCINAL YC JACK FROST SERIES STANDINGS (1/21; 4r, 0t)**

PHRF ≤119 — 1) **Jet Stream**, JS9000 Dan Alvarez, 11 points; 2) **Vitesse Too**, Hobie 33, Grant Hayes, 14; 3) **Red Cloud**, Farr 36, Don Ahrens, 14. (6 boats)

SF30 — 1) **Shameless**, Schumacher 30, George Ellison, 5 points; 2) **Audacious**, J/29, Scott Christensen, 9; 3) **Elusive**, Olson 911, Charles Pick, 11. (4 boats)

Wyliecat 30 — 1) **Uno**, Steve Wonner, 5 points; 2) **Whirlwind**, Dan Benjamin, 9; 3) **Crinan II**, Bill West, 16. (3 boats)

PHRF 120-233 — 1) **Ypso**, Cal 2-27, Tim Stapleton, 6 points; 2) **Synchronicity**, Olson 25, Steve Smith, 11; 3) **Osituki**, Cal 28, Rodney Pimentel, 13. (4 boats)

SANTANA 22 — 1) **Byte Size**, Anna Alderkamp, 7 points; 2) **Bonito**, Jonathan Andrews, 11; 3) **Zingaro**, Jennifer McKenna, 20. (3 boats)

Complete results at [www.encinal.org](http://www.encinal.org).

**Corinthian YC Midwinters**

"I can't remember when we've had wind like this at a Corinthian Midwinters," said Ian Matthew aboard his C&C 29 *Siento el Viento*. The weather gods had surely smiled, for Saturday's miserable forecast had given way to a simply beautiful race day with decent — if a little squirrely — winds and dry conditions. A strong ebb made for longer downwind runs but brought a risk of the traditional pile-up near the finish if the wind died. A few spinnaker boats, once on the water, found the conditions not to their liking ("Uh, Race Committee? We're changing to non-spinnaker division.")

PRO Don Wieneke split the fleets,

**'Team Telefónica' has had some stiff competition in the VOR but has managed to hold onto the lead.**





# THE RACING

TOP ROW PHOTOS FRED FAGO



ALL PHOTOS LATITUDE / ANDY EXCEPT AS NOTED



**Top row:** Windy racing in the Jack Frost. **Left to right:** Don Ahrens' Farr 36 'Red Cloud' in pre-start mode; Olson 25s 'Samba' and 'Synchronicity'; 'Red Cloud' at a finish; Tim Stapleton's Cal 2-27 'Ypso'. **Second and third row:** Same day, at the Corinthian Midwinters. **Clockwise:** the Robinsons' Santana 22 'Belafonte'; Mark Thompson's Catalina 380 'Seaya'; Tom Hintz's Express 27 'Opal'; Gary Proctor's C&C 30 'Meritime'; Bob Rogers' Seaborn 35 'Sunda', Christine Weaver's Laser 28 'Stink Eye' and Rich Korman's Moore 24 'JR'; Jeff McQueen's Tartan 30 'Isle of Skye'; Ron Young's IOD 'Youngster' closes in on Non-Spinnaker 'Seaya'.

sending the bigger boats on a customary point-to-point romp to Yellow Bluff, down the Cityfront to Blossom Rock, around Southamptn Shoal platform and then to the finish, while smaller (read: slower) racers took a couple of loops in the Central Bay.

Gusts and the strong current placed an emphasis on boathandling and reading the water. Many positions were gained or lost due to failure to gauge the cost of heading straight for a mark in the current. Mark roundings, particularly at Yellow Bluff, were complicated by the

north-to-south ebb, forcing several attempts at rerounding by more than one competitor. Once around Yellow Bluff, the bigger fleet dashed to the Cityfront for current relief and a spinnaker show as they ran toward Blossom Rock and then home.

The relatively short courses got the fleets in by about 3 p.m., just ahead of the wind's dying. As results were calculated, we were pleased to see John Clauser's developing program on *Bodacious* eke out a first over Bill Helvestine's *Deception* by a slim six seconds. *Yucca*,

touchingly flying a pennant emblazoned with 'ROB', took first in her division.

Sunday's forecast: rain all day with comparatively light wind. They got the rain right, but steady wind in the 15-knot range made for excellent, if chilly, sailing. The currents were, of course, pretty much a replay of the day before. All fleets were sent toward the East Bay, for a with-the-current finish. Nobody complained about the comparatively short courses because they got the fleet





LATITUDE/PENNY



in early enough to warm up, get home, and watch a football game. Speaking of consistency, though, 11 of the classes are topped by double aces, boats taking first both days. This is not something CYC Mids see in our normal light-air "wildcard" weekends.

— michael moradzadeh

**CORINTHIAN YC MIDWINTERS STANDINGS**  
(1/21-22; 2r, 0t)

PHRF 1 — 1) **Topzy Turvy**, J/111, Warren Konkel, 4 points; 2) **Bodacious+**, 1D48, John Clauser/Bobbi Tosse, 4; 3) **Deception**, Santa Cruz 50, Bill Helvestine, 4. (11 boats)

PHRF 2 — 1) **8 Ball**, Farr 30, Scott Easom, 2

points; 2) **Trunk Monkey**, Farr 30, Jody McCormack, 6; 3) **Encore**, Sydney 36, 8. (10 boats)

PHRF 3 — 1) **Yucca**, 8-Meter, Hank Easom, 2 points; 2) **Baleineau**, Olson 34, Charlie Brochard, 4; 3) **Ahi**, Santana 35, Andy Newell, 6. (10 boats)

PHRF 4 — 1) **Arcadia**, Modernized Santana 27, Gordie Nash, 2 points; 2) **Fjaer**, IOD, Richard Pearce, 4; 3) **Youngster**, IOD, Ron Young, 7. (9 boats)

NON-SPIN A — 1) **Min Flicka**, Hanse 370, Julie LeVicki, 2 points; 2) **Sea Ghost**, Beneteau First 42, Ron Roberts, 4; 3) **Beowulf**, Swan 51, Hakan Bille, 7. (3 boats)

NON-SPIN B — 1) **Seaya**, Catalina 380, Mark Thompson, 2 points; 2) **French Kiss**, Beneteau 350, David Borton, 6; 3) **Kira**, Cal 33-2, Jim Erskine, 6. (10 boats)

NON-SPIN C — 1) **Raccoon**, Cal 20, Jim Snow, 2 points; 2) **Can O'Whoopass**, Richard vonEhrenkrook, 4; 3) **Belafonte**, Santana 22, Jim/

Woody Robinson, 7. ( 10 boats)

EXPRESS 27 — 1) **Shenagigans**, John Collins, 2 points; 2) **Tule Fog**, Steve Carroll, 6; 3) **Opal!**, Tom Hintz, 6. (4 boats)

SF BAY 30 — 1) **Gammon**, Tartan 10, Jeffrey Hutter, 2 points; 2) **Heart of Gold**, Olson 911S, Joan Byrne, 4. (2 boats)

J/105 — 1) **Roxanne**, Charles James, 2 points; 2) **Donkey Jack**, Rolf & Shannon Kaiser, 5; 3) **Joyride**, Bill Hoehler, 5. (4 boats)

CATALINA 34 — 1) **Amandla**, Kurt Magdanz, 3 points; 2) **Jet Lag**, Torin Knorr, 5; 3) **E Ticket**, Michael Mullen, 5. (3 boats)

EXPRESS 37 — 1) **Stewball**, Bob Harford, 2 points; 2) **Golden Moon**, Kame Richards, 4; 3) **Eclipse**, Mark Dowdy, 6. (6 boats)

MULTIHULL — 1) **Caprice**, Seawind 1160, Dan Seifers, 2 points; 2) **Serenity**, Seawind 1160, J.E.B. Pickett, 4. (2 boats)

Complete results at [www.cyc.org](http://www.cyc.org).



# THE RACING

## Race Notes

The 628-mile Rolex Sydney to Hobart Race is one of the two great middle-distance ocean races in the world — along with the Fastnet Race — and is often rough. Eighty-eight boats answered the call on Boxing Day and were blessed with running conditions in the early going. But thanks to a 180-degree windshift that resulted in up to 40-knot winds clashing with a northerly swell from what was left of Tropical Storm *Fina*, the conditions turned miserable.

The battle for line honors turned out to be the fourth closest in the 67-year history of the race. Antony Bell's 100-ft Maxi *Investec Loyal* crossed the finish line just 3m, 8s ahead of *Wild Oats XI* after trading the lead several times. According to Bell, the Maxi's "secret weapon" was none other than navigator Stan Honey of Palo Alto.

The top boat under IRC was the Reichel Pugh 63 *Loki*, but special recognition is due Syd Fischer who finished third in IRC



DAN THIELMAN

**'Tai Kuai' gets dressed up. Her name means 'Too Fast' in Mandarin Chinese. "We like how the Asian characters look on the big spinnaker when we're bearing down on the competition!" said Dan.**

and first in IRC C with the modified TP52 *Ragamuffin*. Fischer is 84 years old! Heck, he was no kid in the early '80s when he was doing Hawaii's Pan Am Clipper Cup.

**New kid in town** — Dan Thielman's new-to-him Reichel Pugh 44, *Tai Kuai*, plans to make her San Francisco Bay racing debut at the Corinthian Mid-

winters this month. Built in '04 in Trinidad for San Diego sailor Les Crouch, *Tai Kuai* (ex-*Storm*) was recommissioned last month at Berkeley Marine Center after spending her youth in the Caribbean.

"I got a heads-up before the boat was listed on the market," said Dan. "I moved quickly when I learned how famously well-built this boat is, and about the boat's

racing exploits, including victories at Key West and Antigua Race Weeks.

"This year we hope to compete in the YRA races, Big Boat Series, Spinnaker Cup and Coastal Cup. I also aspire to some day compete in a TransPac Race to Hawaii."

Dan recently sold his Sabre 386 *Kuai*. "I started campaigning a Melges 20 in 2010 at circuit events around the U.S. and it became clear to me that my racing aspirations had grown bigger than what I could accomplish in the Sabre."

— latitude / chris



**Specializing in Rigging and Composites for Racers and Cruisers**

**STOP PUTTING IT OFF!**  
REPLACE THAT OLD RIGGING BEFORE THE SUMMER WINDS KICK IN!

**15% OFF**  
any standing rigging  
order placed  
in February!



**Pacific Cup boats welcome:**

- Offshore sheets and halyards
- Mast service
- Equipment upgrades
- Rig Tunes
- Emergency steering systems
- Winch service

**Composites:**

- Carbon and fiberglass construction and repair
- Composite interior sliding hatches / Bow hatches
- Emergency rudders and cassettes
- Lightweight hard dodgers
- Crash pads to protect your deck
- Fiberglass and gelcoat repair

**310 W. Cutting Blvd., Pt. Richmond, CA 94804 • 415.533.2915 • [www.gcmarine.net](http://www.gcmarine.net)**



# SIGN UP FOR THE 2012 RACING SEASON

Entry Form  
next page!



## Welcome to YRA Racing, the best racing value on the bay!

Thank you for participating in the YRA! We offer a choice for racing both on the Bay and on the local ocean!

### SERIES INFORMATION

#### **The YRA Party Circuit**

- Includes the 3 marquee YRA Weekend Regattas plus the 1 day Summer Sailstice Regatta. Weekend regattas are The Great Vallejo Race, the YRA 2<sup>nd</sup> Half Opener, and the YRA Season Closer. The three weekend regattas features 2 days of racing and a party at the host club Saturday night.
- Each race is a stand-alone regatta.
- There are 6 Divisions available for each Regatta: PHRF, Sportboat, One-Design, Double/Singlehanded, Non-Spinnaker & Multihull. Divisions may be split into multiple fleets to ensure competitive racing.

#### **The YRA Series**

- In the Bay racing for boats with a current NCPHRF rating certificate (HDA) or for One-Design classes (ODCA).
- The series consists of 6 races- YRA 1 (1 race) YRA 2 (2 races) YRA 3 (one race) YRA 4 (2 races).
- HDA Divisions are determined by grouping similarly rated boats.
- YRA Series Racers are invited to race in the Crewed Lightship 1 race for an additional \$5.00. Additional OYRA equipment requirements must be met. See [http://www.yra.org/OYRA/ocean\\_safety.html](http://www.yra.org/OYRA/ocean_safety.html).
- One-Design starts are available for any fleet that signs up for the ODCA season, or, gets at least 5 boats to sign up for a single race day. If you are not sure if your One-Design fleet is a current ODCA fleet, or would like to sign your fleet up for ODCA, please contact the YRA office at (415) 771-9500 or [info@yra.org](mailto:info@yra.org).

#### **OYRA (Offshore Yacht Racing Association)**

- In 2012, there are 9 ocean races ranging from 25 to 60+ nautical.
- OYRA racers are invited to race in the Vallejo race for an additional \$5.00
- Racers will be divided into divisions determined by the OYRA board. Racers can also choose to race in the Short Handed division:

#### **WBRA (Wooden Boat Racing Association)**

- The WBRA participates in the US Sailing Golden Anchor program which makes WBRA racers eligible for a discounted US Sailing Membership. US Sailing memberships through the WBRA Golden Anchor program must be purchased online here: <http://www1.ussailing.org/membership/MPP/Default.aspx?ycid=112274N>
- Bay racing for one of the following 5 fleets:
  - Bird Boats
  - Bear Boats
  - Folkboats
  - IODs
  - Knarrs

### GENERAL INFORMATION

- **YRA Sailing Instructions are available on the YRA website at [www.yra.org](http://www.yra.org).** Sailing instructions are normally posted approximately 2 weeks prior to each race. If you do not have access to the internet and need to have your race instructions mailed to you, please contact the YRA office at (415) 771-9500 or [info@yra.org](mailto:info@yra.org)
- Entries for a series, or individual regatta, must be received by 5 pm the Monday before the race or a \$35 late fee will be applied. No entries will be accepted after 5 pm the Wednesday before a race.
- **A YRA sailing membership and a membership in a YRA member yacht club is required to register a boat for any YRA series.** A YRA membership is required to race in any individual YRA Race, but one time racers do not need to belong to a member club.
- The YRA Offers a discount on all race fees to US Sailing Members. YRA Racers are eligible for a discount on US Sailing Memberships through the Golden Anchor Program. US Sailing Memberships can be purchased online at <http://www1.ussailing.org/membership/MPP/Default.aspx?ycid=101132Z>.
- Sailors entering the OYRA Season, or any individual OYRA Race, must submit a signed OYRA Boat/Crew Information and Statement of Compliance Sheet before each ocean Race. See [http://www.yra.org/OYRA/ocean\\_safety.html](http://www.yra.org/OYRA/ocean_safety.html) for more information. **Please note that to race in an OYRA Race a 406 EPIRB or 406 PLB is required.**
- Please fill out your entry form completely, sign, date and return it to the YRA office along with your payment. If you need additional assistance completing this form, please contact the YRA office.
- You can save time and postage by signing up online! Visit [www.yra.org](http://www.yra.org) for more information!



# Yacht Racing Association of San Francisco Bay - 2012 Entry Form

1070 Marina Vaillage Pkwy., Suite 202-G  
Alameda, CA 94501  
Phone: 415.771.9500  
Fax: 415.276.2378  
email: info@yra.org

Name: \_\_\_\_\_ Boat Name: \_\_\_\_\_ Sail Number: \_\_\_\_\_  
 Street: \_\_\_\_\_ Boat Model: \_\_\_\_\_  
 City,State,Zip: \_\_\_\_\_ Manufacturer: \_\_\_\_\_ Yr Built: \_\_\_\_\_  
 Evening Phone: \_\_\_\_\_ Daytime Phone: \_\_\_\_\_ Designer: \_\_\_\_\_ Yr. Designed: \_\_\_\_\_  
 Email Address: \_\_\_\_\_ U.S. Sailing #: \_\_\_\_\_ YRA Member #: \_\_\_\_\_  
 Yacht Club Affiliation: \_\_\_\_\_ Marina: \_\_\_\_\_ Berth/Slip #: \_\_\_\_\_

<b>Membership Fees:</b>	YRA Membership:	<b>Required for YRA Racing</b>	\$45	\$ _____
<b>NCPHRF Fees:</b>	Renewal of 2011 Certificate:		\$30 for YRA Members/\$40 for NON-YRA Members	\$ _____
	New Certificate/Renewal of 2010 or prior Cert.:		\$45 for YRA Members/\$55 for NON YRA Members	\$ _____

<b>Season Racing Fees:</b>	<b>US Sailing Members</b>	<b>Non US Sailing Members</b>	<b>Fleet</b>
YRA Party Circuit (Vallejo, 2nd Half Opener, Season Closer, Summer Sailstice)	\$150	\$165	\$ _____
YRA Series + Party Circuit (HDA/ODCA, Includes Party Circuit)	\$180	\$195	\$ _____
YRA Series only (HDA/ODCA, no Party Circuit)	\$150	\$165	\$ _____
Offshore Yacht Racing Association (OYRA) Full Season *	\$195	\$210	\$ _____
Wooden Boat Racing Association (WBRA) Season	\$150	\$165	\$ _____

<b>Single Race Fees:</b>	<b>US Sailing Members</b>	<b>Non US Sailing Members</b>	<b>Fleet</b>
YRA Spring/Summer Series racers entering Lightship *	\$5	\$10	\$ _____
OYRA season racers entering Vallejo	\$5	\$10	\$ _____
Vallejo Race Only	\$75	\$80	\$ _____
2nd Half Opener Only	\$75	\$80	\$ _____
Season Closer Only	\$75	\$80	\$ _____
All other YRA Races (write in race name):	\$50	\$55	\$ _____

**Late Fee:** **No entries are accepted after 5pm the Wednesday before the race**  
 Any entry Rec'd after 5pm the Mon before the race \$35 \$ \_\_\_\_\_

**\* Participants in an ocean race or ocean series must submit a signed OYRA Boat/Crew Information and Statement of Compliance Sheet before each ocean Race. See [http://www.yra.org/OYRA/ocean\\_safety.html](http://www.yra.org/OYRA/ocean_safety.html)** **TOTAL** \_\_\_\_\_

In consideration of being admitted to sailing membership in the Yacht Racing Association of San Francisco Bay (YRA), I agree to abide by "The Racing Rules of Sailing" and the Sailing Instructions of the YRA and the regatta sponsors. I warrant that I will maintain compliance with the YRA Minimum Equipment requirements. To the fullest extent permitted by law, I hereby waive any rights I may have to sue the YRA with respect to personal injury or property damage suffered by myself or my crew as a result of our participation in the YRA and hereby release the YRA and it's race organizers from any liability for such injury or damage.. I further warrant that I have not relied upon any of the above entities or individuals in preparing my yacht for racing.

Signed: \_\_\_\_\_ Date: \_\_\_\_\_

Make check payable to YRA. To pay by MasterCard or Visa please provide card info below, including billing street address and zip code

Card Number: \_\_\_\_\_ Exp Date: \_\_\_\_\_ CV # \_\_\_\_\_ Name on Card: \_\_\_\_\_

Card Holder's Signature: \_\_\_\_\_ Billing Address: \_\_\_\_\_

<b>Office use only</b>			
C.C.	Check Number _____	Amount PD _____	DATE Received in office _____







**dewitt**

Unveiling the new  
**Limited Edition print series  
 of America's Cup Images  
 by artist Jim DeWitt.**

**Call Pam at  
 (510) 236-1401 for details.**

**DeWitt Art Gallery & Framing**

121 Park Place, Point Richmond, CA 94801

(510) 236-1401 • [www.jimdewitt.com](http://www.jimdewitt.com) • [www.dewittgalleryandframing.com](http://www.dewittgalleryandframing.com)

Wednesday-Saturday 11:00-6:00 • Sunday 11:00-5:00

**HAWAII**

**LONG TERM DRY STORAGE**

*Clear Customs at our dock*

**GENTRY'S  
 KONA MARINA**

**HONOKOHAU HARBOR**

156°1'30" W  
 19°40'20" N

TOLL FREE **888-458-7896**

[www.gentryskonamarina.com](http://www.gentryskonamarina.com)

The friendliest boyard in Hawaii



**Start Line Strategies**

**Winning Legal Planning  
 for Sport Programs**

*10 years America's Cup Experience*

Sponsor & Venue Arrangements • Crew Contracts  
 Vessel Shipping Logistics • Charter Agreements

**Ashley Tobin**

(925) 324-3686 • [amtobin@comcast.net](mailto:amtobin@comcast.net)



*Specializing  
 in Sail Repair  
 and Service.*

**Marchal Sailmakers**

2021 ALASKA PACKER PLACE, ALAMEDA, CA 94501

Dominic Marchal • (510) 239-5050

[www.marchalsailmakers.com](http://www.marchalsailmakers.com)



**SLIDING PIVOT SUPPORTS**

Solar panel rail mounts,  
 pivoting, adjustable slides.



**TEAK SEAT**

Collapsible, fits straight rail  
 or in corner,  
 swing-down support leg.



**COCKPIT  
 TABLE  
 MOUNTING  
 HARDWARE  
 KIT**

Lightweight, anodized  
 aluminum, adjustable,  
 collapsible, easily removable.  
 Extra base plate to use the  
 table in both cockpit and  
 salon. Tabletop available in  
 StarBoard, teak or make  
 your own. Solar mounting  
 hardware available, too.

**HOTWIRE ENTERPRISES**  
[www.svhotwire.com](http://www.svhotwire.com)

Phone/Fax 727-943-0424  
 email: [hotwiregam@aol.com](mailto:hotwiregam@aol.com)



# WORLD

With reports this month on **Increased Buying Power in the Eurozone**, **A Carefree Cruise Through Croatia**, and a **BVI Charter Addict's Reasons for Returning Again and Again**.

## **Trending Now: More Bang for Your Bucks in Europe**

You have to look pretty hard to find anything positive in the news these days. But believe it or not, there's actually some very good news in the financial pages — at least if you're a potential traveler. Although most financial analysts agree that America's economic recovery is still only sputtering along, it looks absolutely gold-plated lately compared to that of Western Europe. So if you haven't even considered a European vacation for the past decade or so, it may be time to reassess.

Suppose you'd squirreled away \$5,000 for a sailing vacation. In June of '07 or '08 that would have netted you 3,150 euros at a currency exchange. But today, you'd get 3,950 euros — an increase of about 25%! That's not to say that Western Europe has become dirt cheap, but this trend is certainly worth noting. Imagine your reaction, for example, if you'd been itching for a European sailing getaway for years, and you were suddenly offered a 25% discount on all goods and services. Enticing, no?

So let's take a look at the options. In addition to the vast fleets of crewed charter yachts available in European ports — which include some of the most luxurious sailing yachts in the world — there are hundreds of late-model bareboats based in the Mediterranean, Adriatic and Baltic Seas. From Malta to Finland and every waterside nation in between there

***Yachts and tour boats moor beneath the ancient battlements of Bodrum Castle, on Turkey's Turquoise Coast.***



KIRIACOULIS YACHT CHARTERS

are several thousand miles of enticing cruising grounds whose topographical attractions range from the glacier-carved fiords of Norway and Sweden to the sun-baked beaches of Greece and Turkey.

It practically goes without saying that Western Europe's rich cultural history is one of its most alluring attributes. From the ancient Mediterranean harbors where international commerce boomed long before Columbus set foot in the New World, to ruins found in Greece and Turkey that pre-date written history, Europe offers historical significance to travelers unmatched by any other sailing region.

Because of this, it's an ideal place for a so-called surf-and-turf vacation. The idea is to dedicate part of your travel time to land travel and part of it to exploring under sail. We highly recommend designing such a combo-plate itinerary as a way to introduce kids or neophyte charterers to the joys of vacationing under sail. But be sure to schedule the sailing portion last, as it will almost certainly be the highlight.

Deciding which European venue to charter in depends on your social style and the activities you enjoy. For sun worshipers, the southern latitudes of Greece and Turkey are a perennial favorite, with the bonus that remnants of ancient history are everywhere. (Turkey does not yet use euros, by the way, but it is very inexpensive.)

In addition to the chic and sophisticated French Riviera in the south of France, Brittany, on the Atlantic coast, is a splendid sailing center with fascinating cosmopolitan history.

There are at least three regions of Italy with charter bases, including Sicily, which gives access to the charming and timeless Lipari Islands, where old-world traditions are still strong. (Imagine a surf-and-turf trip that included an art tour of Florence and a week of sailing in the Med.)

Both the French island of Corsica and the Italian island of Sardinia have charter bases, as do Spain's Balearics, all of which offer a balance of semi-secluded anchorages and bustling towns with world-class din-

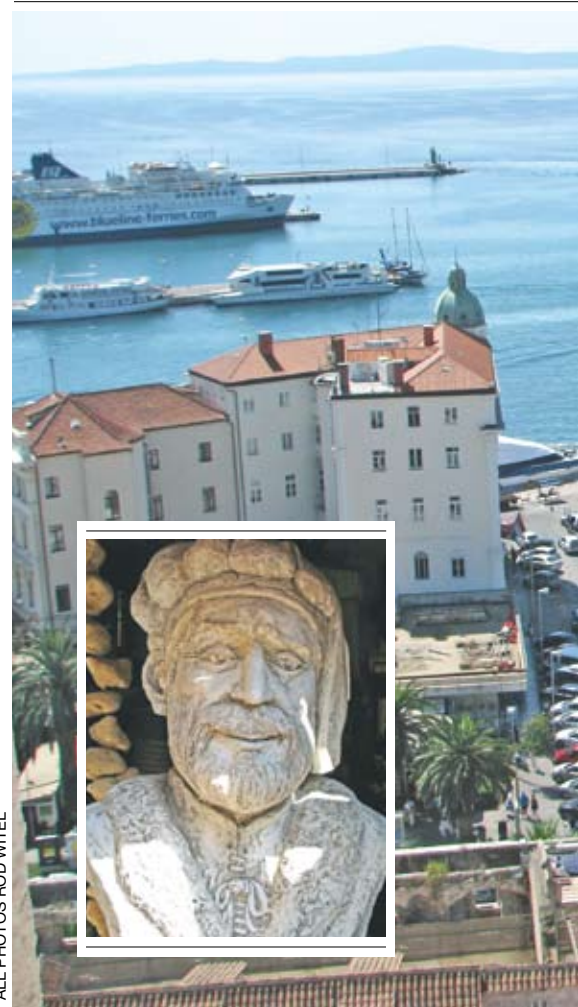

ALL PHOTOS: ROD WITEL

ing and nightlife. Farther north, you can find bareboat bases in the British Isles and Scandinavia that give access to mazes of stunningly beautiful cruising grounds that would take years to thoroughly investigate.

If you can't find a boatload of friends or family members to join you, be aware that Europe's biggest charter operators, Sunsail, The Moorings and Kiriacoulis, all offer pay-by-the-berth flotilla charters, as do smaller companies such as the Greek specialist, Albatross.

For most Americans, a vacation to Europe is always a bit of a splurge, but with the euro getting weaker, this summer would seem to be an ideal time to finally make your European sailing fantasies come true. We'd advise you not to procrastinate in locking in a boat, though. The summer season will be here before you know it.

— latitude/andy

## **Sailing Through History in Culturally Rich Croatia**

I don't have the sailing pedigree of many *Latitude 38* readers, but I do love warm water chartering and wandering



# OF CHARTERING

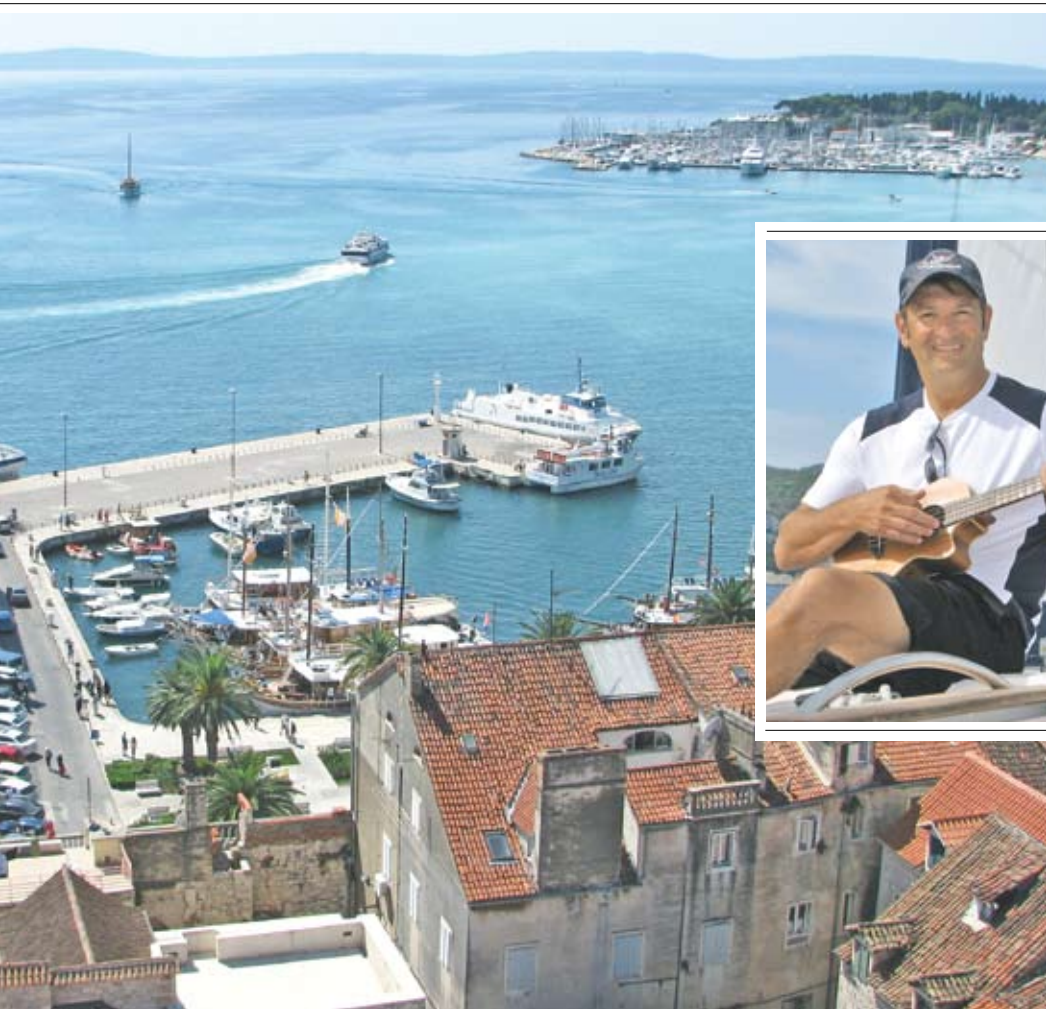

**Every port along the coast seemed to be torn from the pages of a storybook. Left: Marco Polo's bust. Right: Rod strums a tune.**

the world.

That was enough impetus to cross the pond and a few more seas to reach Croatia with my sailing buddy Chuck Dell'Ario last September for a one-way charter from Split to Dubrovnik.

We chartered from a small local company called SunLife ([www.sunlife.hr](http://www.sunlife.hr)). We were pleased with their service as well as the quality and price of our boat, a 2006 Elan 384 Impression monohull named *Navis*. This being our first visit to the former Yugoslavia, we felt trepidation about language, currency and navigation. All our worries were for naught as the staff of most businesses were multilingual. We fared better with kunas (the Croatian currency) than euros, and navigation was line-of-sight. We attempted to speak Croatian (albeit feebly), but even the locals admit that their language is "very difficult and has too many letters." We Americans are lucky that much of the world speaks English.

Day temperatures hovered in the mid-80's, and the nights cooled for very

comfortable sleeping. Winds were light in the morning and picked up to 10 to 12 knots in the afternoon. Much of Europe enjoyed a warmer and drier September than usual. In fact, the only rain we saw for 14 days was on our second morning. It lasted for just over one hour. We were in shorts or bathing suits day and night. It was charter heaven.

We departed from Split, a large, beautiful, ancient walled city, and zig-zagged our way south-east through Croatia's famed Dalmatian archipelago, exploring a different island every day. Some of the highlights were:

- The seductive city of Trogir protected by its Kamerlengo Castle.

- The quaint town of Milna on the isle of Brač (one of our favorite stops, where we bought some local olive oil, wine and grappa).

- Zlatni Rat (Golden Cape), one of the most

famous beaches in Croatia (also on Brač).



- The spectacular blue caves on the island of Bisevo (our westernmost port of call and a must-see).

- The notorious party town of Hvar Town on the island of Hvar with its obligatory 87-meter climb to Fortress Spanjol, which overlooks the harbor.

- The tourist Mecca of the fabled walled city of Korčula (home town of Marco Polo).

- The island of Mljet, its National Park and salt water lakes.

- And finally the great walled city of Dubrovnik, which no one should miss if they are ever to visit Croatia.

Our daily routine usually consisted of breakfast on the boat before strolling the small farmers' markets and bakeries to gather fresh provisions. Mid-morning we'd cast off and motor or sail until early afternoon, when we'd find an idyllic cove where we would anchor for lunch and a swim in the warm, blue Adriatic Sea.

If you are used to snorkeling the Caribbean or South Pacific coral reefs, you'll be somewhat disappointed in the Adriatic, as there's not as much to see underwater. Anchoring proved a bit difficult as the sea bottom is a combination of rocks and grass and our boat had a Danforth anchor — not a good combination. We did have an all-chain rode, however, which helped in the deep waters that surrounded all the islands

**Another day, another amazing destination. Chuck prepares to get underway at the coast town of Milna on the isle of Brač.**







*In every photo they sent us, Rod and Chuck were smiling. From that we surmise that they had a splendid trip.*

we visited.

After weighing anchor we would sail to our evening's destination, where we would Med-moor (stern-to) at one of the large ACI marinas. ACI has a chain of marinas in the larger cities, with ultra-modern facilities, restaurants, sailing schools, pools and tennis courts. With shore hookup for AC and water they were about \$93 per night. In smaller, more quaint locations, we'd tie up to the city dock, where there was no charge, but no guarantee of AC or water.

More often than not, our stern would be only steps away from restaurants and/or castles. Unlike the BVI, there was no rushing for mooring balls or slips, but we did hear that in July and August some areas can be inundated with tourists and charterers. We also anchored out a few evenings for the sheer beauty of it.

Many times late in the evening we'd hear groups of folk singers performing at pubs and restaurants, their beautiful four-part harmonies resonating through the harbor. We felt privileged to be privy to such local charm.

In summary, we traveled approximately 300 nm, yet saw very few Americans — except in Dubrovnik where the cruise ships congregated. We did see far more monohulls than catamarans, with the majority of the monohulls utilizing in-mast furling mainsails. One of the only negative things I have to report is that Croatia, sadly, still allows the dumping of sewage anywhere. Holding tank usage is not required or even encouraged.

Still we fell in love with the country, its people, its food — especially the delicious gelato, which we ate way too much of — and, of course, the sailing. But please don't tell anyone, as I want Croatia to be just as I left it when I return — right after I work my way down my must-do list that includes Bora Bora, Turkey, Italy, and others.

— rod witel

### Working Vacation in a Third World Nation

Feels like I'm living the lyrics of a Jimmy Buffett song: "Working vacation in a third world nation." Not that the British Virgin Islands meet the classic definition of Third World, but this lovely group of islands seems far removed from any semblance of so-called First World society.

I first fell in love with the BVI when Captain John and I rented a bareboat on our honeymoon in 1994. On that wonderful cruise we discovered the "nature's little secrets" that the BVI Tourism Board so often touts in their ad campaigns.

A couple years later, we returned after stumbling into this crazy job — running charter yachts — that actually paid us to sail on beautiful boats, go snorkeling ev-

ery day, lead nature hikes, and make a few fancy meals. There must be a catch, we thought. Oh yeah, you should probably like people. Hosting total strangers in a very intimate environment is never boring and usually at the end of the week, they leave as friends.

After several years working in the crewed yacht industry running company-owned boats, plus a five-year stint running our own charter yacht, we keep getting drawn back to the islands, their people and the wonderfully appealing Caribbean lifestyle.

I still love sharing the BVI with first-timers and getting to re-live it through new eyes. When our neighbors from Bel Marin Keys

(who are veterans of the '08 Baja Ha-Ha) asked us to organize a bareboat trip, we jumped at the chance to once again show off the islands to a group of "virgins." Early last December, we rented the Leopard 45 cat 'ti *Profligate* from BVI Yacht Charters and revisited our favorite spots.

Do you want a quiet cove to yourselves or a hub of watersports activities and nightlife? The close proximity of islands in the BVI and the variety of anchorages provide something for everyone.

One of my favorite BVI destinations is Anegada, a low-lying coral-formed island that contrasts with the rest of the archipelago's tall, volcano-formed isles. Because Anegada lies well away from the rest of the chain, the first-timers might wonder if they were headed across the

***Blasting across open water aboard a smooth-sailing catamaran, powered by the warm Caribbean trades — it doesn't get much better.***





# OF CHARTERING

Atlantic, as you can't see this flat, coral and limestone island when you first start heading there. It's the longest island-to-island sail in the territory, and usually one of the nicest, as the easterly trade winds provide a lovely beam or close reach from Virgin Gorda. Anegada offers visitors miles of pristine, uncrowded beaches, lobster barbecues, fabulous snorkeling, perhaps a flamingo sighting, and a magic atmosphere with a laid-back vibe. Some people get it the minute they land ashore, others may take awhile to learn how to live by the rhythms of nature, unplugged from the busy lifestyle they are used to.

In addition to the well known "must-see" destinations in the BVI, it's always fun sharing our favorite secrets, such as lesser-known snorkel spots, the funkier of beach bars, or rarely traveled hiking trails. If you are first timers to the BVI, try to find locals willing to share a few



**Is there a BVI sailing vacation in your future? If so, Lynn recommends making the crossing to laid-back, low-lying Anegada.**

of their favorite secrets in exchange for some chilly beverages — you just might end up with some salty sea stories as a bonus.

On our recent trip the islands worked their magic as always. Our neighbors be-

came smitten with the BVI and are already planning another trip.

After we returned the boat and were walking around Village Cay Marina on Tortola, we bumped into Bob Carson, yacht broker and manager of several private crewed yachts, and he was in a bit of a dilemma as the crew he had hired to operate a brand new 45' catamaran had just quit shortly before the first charter.

We signed on immediately and climbed back in the saddle. After provisioning, we picked up our guests and had the pleasure of showing off the BVI once again — and even got paid to do it!

— Lynn Ringseis

*Thanks Lynn. We appreciate you doing this tropical reconnaissance in order to bring our readers a BVI update. Tough duty!*

— Ed.

**Real People. Real Sailing. Real Fun.**



Sail Cats | Power Cats  
Monohulls | Trawlers  
Bareboat | Skippered

**Real Choices.**

Choose CYOA and become part of the family. We've been providing beautifully maintained yachts, personal service and sensible prices to sailors since 1980.



**CYOA**  
YACHT CHARTERS

1-800-944-2962  
info@cyoacharters.com  
www.cyoacharters.com  
St. Thomas USVI 00802



Tortola BVI  
Belize  
The Grenadines

**UNIQUELY**  
**TMM**



Marisa  
TMM Belize

Most charter companies offer blue water & palm trees, but it takes the personalized care of people like Marisa to make your vacation a success.

Like Marisa, everyone at TMM is committed to your complete satisfaction. Our specialized three-location operation offers large company quality with small company service. A combination that is uniquely TMM.

**TMM**  
Yacht Charters  
Since 1979

**1.800.633.0155**  
www.sailtmm.com

catamarans • monohulls  
motor yachts  
ownership programs



**BVI YACHT CHARTERS**

Call: +1 888 615 4006  
Or: +1 284 494 4289

BVI Yacht Charters is the first port of call for all yacht charters in the BVI and St Martin. Whether you are looking for a Catamaran or a Monohull, a week or just a few days, our professional team is on hand to make it work, your way.

## BVI YACHT CHARTERS

\*\* 10% off all new bookings when you mention this ad. [www.bviyc.com](http://www.bviyc.com)  
[charters@bviyc.com](mailto:charters@bviyc.com)

[www.pacificmaritimelaw.com](http://www.pacificmaritimelaw.com)

### Maritime Law Offices of Jared A. Washkowitz

SF Bay Area | So. Cal. | Hawai'i

Vessel Documentation  
Fed. & State Regulation  
Charter Parties  
Personal Injuries  
Wrongful Death  
Maritime Liens  
Vessel Arrests  
Limitation of Liability  
Towage

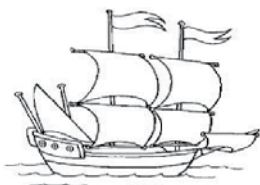

Collision/Allision  
Vessel Financing  
Cargo Loss & Damage  
Longshore Act  
Jones Act  
Wreck Removal  
Salvage  
Marine Insurance  
+ other practice areas

Email: [jaw@pacificmaritimelaw.com](mailto:jaw@pacificmaritimelaw.com)

PH: +1 (415) 320-8254 (Calif.) | +1 (808) 840-7410 (Haw.)



## ATLANTIC 57 CATAMARAN™



THE ORIGINAL PILOTHOUSE CATAMARAN  
o Designed for easy shorthanded cruising  
o Spectacular windward performance  
o Cored epoxy/glass/carbon construction

**CHRIS WHITE DESIGNS**  
TEL: 508-636-6111  
[www.chriswhitedesigns.com](http://www.chriswhitedesigns.com)

## Ryan's Marine

Specializing in Marine Electrical  
Services for Your Boat

- Electrical system installations from inverters to electronics packages
- Troubleshooting of existing systems
- Dealer for the complete Balmar product line
- Head and holding tank installations

Featuring  
ESPAR  
hydraulic heater  
installations

MEMBER  
**ABYC**  
Setting Standards for Safer Boating

**(510) 385-3842**

Ryan Schofield  
Owner since 1997

email:  
[rssailor@yahoo.com](mailto:rssailor@yahoo.com)

## Bilge Steam Cleaning Oil Changes

Professional service at your slip!!!

**MarineLube** 877 744-2244

[www.MarineLube.biz](http://www.MarineLube.biz)



Fuel Polishing

Tank Cleaning

**Boat Loans**



Marine Financial Services

Same people, same places,  
new name, new look!

Dimen Financial is now  
Sterling Associates. Now  
you can look to Sterling for  
the best rates and terms.



Northern  
California

**Bill Kinster**

**(925) 672-3993**

[bill.boatloans@gmail.com](mailto:bill.boatloans@gmail.com)

Fully insured  
Local & long distance



**Riverside Marine  
Transport Inc.**

ICCMC# 624516

Contact Wayne Harris for efficient, safe yacht transport:

**(941) 713-4134**

[www.largeboathaulers.com](http://www.largeboathaulers.com)

[wayneharrisflhome@earthlink.net](mailto:wayneharrisflhome@earthlink.net)

6150 State Road 70 E., Bradenton, FL 34203



# SAN JUAN ISLANDS



## 6-Day Learn-N-Cruise

Fly to Bellingham, WA and complete your American Sailing Association Basic Sailing through Bareboat Charter Certifications during a Saturday 1pm - Friday 1pm live-aboard week exploring the spectacular San Juan Islands. Tuition only \$1395, including food! (Airfare SFO/OAK to BLI approx. \$350)

*No experience like this for the price in the SF Bay Area!*



**CHARTER**  
40 Exceptional Yachts  
from 30 - 49 feet

30 Years of Sailing Excellence

We certify more Bareboat Skippers than any other school in the Northwest!

1-800-677-7245 • [www.sanjuansailing.com](http://www.sanjuansailing.com)

## Are "Californians Dreaming?"

Stop dreaming – go sailing.

**CALL TO RESERVE AT OUR  
BEST IN THE BVI PRICES!**



## Conch Charters

Since 1986  
25th Charter Season

[www.conchcharters.com](http://www.conchcharters.com)

**(800) 521-8939**





**PAS**  
www.practical-sailor.com  
BEST CHOICE 2010

**ALPENGLOW LIGHTS** 406.889.3586

**Hand Crafted, High-Efficiency Area Light**  
LED Reading & Berth Lights – *NEW* Dimmable Model

- Better light quality; superior color rendition
- Lower battery drain!
- Variety of wood selections to match your interior
- Night-vision and Splashproof options available
- Choose LED or CFL (compact fluorescent)



Alpenglow Lights, LLC, P. O. Box 415, Eureka, MT 59917  
[www.alpenglowlights.com](http://www.alpenglowlights.com)



## Save Your Aft!

Using one of our 1900+ patterns or your own pattern, let our craftsmen create a comfortable, durable, and stylish set of all-weather cushions for your cockpit. Find your custom, closed cell foam cushions at [www.bottomsiders.com](http://www.bottomsiders.com)!

## BottomSiders

**BottomSiders**  
2305 Bay Avenue  
Hoquiam, WA 98550

Call Toll Free: **(800) 438-0633**  
[cushions@bottomsiders.com](mailto:cushions@bottomsiders.com)  
Fax: 360-533-4474

# COMPUTER ABOARD?

CAPN • GPS • AIS  
Marine Cellular & WiFi  
Iridium • Inmarsat • Globalstar  
ICOM SSB Radio • Pactor Modems  
*Wireless E-mail Specialists*



**SEATECH SYSTEMS™**  
800.444.2581 • 281.334.1174  
[info@sea-tech.com](mailto:info@sea-tech.com) • [www.sea-tech.com](http://www.sea-tech.com)

**Navigation, Communication & Weather**

## QUALITY CRUISING SAILS FOR LESS!



**MAINSAILS  
MIZZENS  
STAYSAILS  
HEADSAILS  
SPINNAKERS  
SAILCOVERS  
STRONGTRACK**

[leesailsca@yahoo.com](mailto:leesailsca@yahoo.com)

(707) 386-2490

**SAILMAKER TO THE WORLD**

# CHANGES

With reports from **Flashgirl** in New Zealand on Commodore's upcoming 80th birthday party to be held in Sausalito; from **Sea Level** in Indonesia on the way to Thailand; from **Curare** in Valdivia, Chile, on a less-traveled route; from **Pacific Breeze** on four summer weeks in Greece; from **Rascal** in Southeast Asia; and an unusually large helping of **Cruise Notes**.

## Flashgirl — Wylie 38+ Commodore and Nancy Tompkins PNG, Micronesia, Vanuatu (Mill Valley)

Just before the end of the year, we had a Wild Toad's ride from Vanuatu to Opuia, New Zealand, running before tropical cyclone *Fina*. Just before setting sail, we took the time to reflect on the things we did this past year.

In addition to holding loved ones near and dear, we sailed a distance of 5,500 miles and visited 34 islands. We started the beginning of the year at Thursday Island, which is north of Cape York, the northeasternmost tip of Australia. We then sailed through the Gulf of Papua and the Coral Sea. We spent the month of January cruising PNG, then headed north across the equator to Micronesia, stopping at the remote atolls of Kapingamarangi and Nukuoro enroute to Pohnpei.

We moored *Flashgirl* in Pohnpei for six months, and Nancy flew home to visit her family and take care of business. She returned to the boat in mid-June, and we enjoyed Micronesia for about six weeks before heading south across the equator, which was Nancy's fourth crossing. Our next stop was the Solomon Islands. We

*Commodore's favorite Vanuatu string band, all dressed up as Santas to get into the spirit of Christmas in the South Pacific.*

NANCY / FLASHGIRL



*It takes a real man to drive holding an umbrella.*

cleared into Honiara on Guadalcanal, and then headed east to the remote Temotu Province where we visited Utupua and Tikopia. Tikopia was a highlight for us. A small island less than two miles long and half a mile wide, it has been inhabited by Polynesians since 1200 B.C. It is still ruled by four chiefs, called *arikis*, and much of their culture is still intact.

After a few weeks we moved on to Vanuatu, where we spent three months. In mid-December we left Port Vila for Opuia, Bay of Islands, New Zealand on what was a thrilling 1,200-mile sail. We saw 25-30 knots under gray skies most of the time, and the apparent wind angle was 40 to 60 the whole way. Ugh! But we covered the 1,200 miles in just seven days, so *Flashgirl* rocked!

We are so glad to be tucked away in port here at Opuia, as the nasties that chased us most of the way — tropical cyclone *Fina* — finally made landfall here, although only as a tropical depression. After all the hot and muggy days in the tropics, we're enjoying the cooler weather.

— nancy and commodore 01/01/12

*Readers — We'd like to remind everyone that Commodore, who has been sailing across oceans for 79 years, will be celebrating his 80th birthday on February 26 at the Presidio YC at Fort Baker (Marin Headlands). The celebration is from noon until 4 pm, and all his friends, as well those who love sailing, are invited.*

## Sea Level — Schionning 49 Jim and Kent Milski Indonesia to Singapore

(Lake City, Colorado)

As the night faded into day, we counted five volcanoes in the distance off to starboard. I wondered how many places in the world it would be possible to do that. And it brought to mind the Johnny Cash song titled *Ring of Fire*. It burns, burns, burns, the ring of fire.

My wife Kent and I have been cruising the southern coast of Java, a 550- by 100-mile island with the Java Sea to the north and the Indian Ocean to the south. Java has a population



of 135 million, making it not only the world's most populated island, but one of the world's most densely populated regions. Sixty percent of Indonesians live on Java, and much of Indonesian history has taken place here. For example, it was the center of powerful Hindu-Buddhist empires and Islamic sultanates, the core of the colonial Dutch East Indies, and was at the center of Indonesia's campaign for independence. Java dominates Indonesian social, political and economic life.

The preferred route for cruisers heading west is the north shore of Java, as it's the shortest route to Singapore and the sailing paradises of Langkawi, Malaysia, and Phuket, Thailand. But except for the adverse current at this time of year, the south coast of Java is itself a cruisers' paradise. Parts of the southeast coast are amazingly pristine, with plenty of protected anchorages and undiscovered surf spots. And we've found the people

NANCY/FLASHGIRL





# IN LATITUDES



PHOTOS COURTESY OF INDO PHOTOBANK

**Java is an island of big contrasts. Spread; One of the many great waves along the often pristine south coast. Inset above; With 20 volcanoes being active in recent years, Java is Volcano Central. Inset left; Thanks to severe overpopulation, the Citarum River is almost a solid mass of plastic bottles.**

to be extremely gregarious and helpful — although this has been the case almost most everywhere we've been. The Javanese are also very curious about our catamaran.

The Indonesian Coast Guard helped us resupply with fuel at our last stop. This is noteworthy, because while getting fuel for yachts isn't a problem along the cruiser 'milk run' on the north coast of Indonesia, including Bali, it's a different story on the less-traveled south coast. The problem is that Indonesian filling stations aren't allowed to sell fuel in jugs to just anyone. You need to be a fisherman with a permit. We hadn't planned to use as much fuel as we did, but at this time of year the wind and current are against westbound boats.

Our plan is to make our way up the west side of Sumatra — the other big

Indonesian island — to visit the offshore Mentawai Islands, which are famous for great surf. Then in mid-January we will cross the Andaman Sea to Langkawai, Malaysia.

We were traveling alone at this time because of our route and because we were running a little late compared to most cruisers for a trip from Indonesia to Singapore and Malaysia. But we certainly enjoy buddy-boating when given the opportunity, as we think it's much safer and more fun.

To turn back the clock for a moment, we spent most of the last winter cruising

Down Under. We sailed as far south as Tasmania, then back up the length of the east coast of Australia. By the way, the length of the east coast of Oz is about 3,000 miles! The island of Tasmania was our favorite part of Australia.

Cruisers headed to Australia need to be aware that Oz is much more expensive than the United States! That's why so many Aussies have been flying to California to buy boats. And why so many Aussies cruise Indonesia, Malaysia and Thailand, which are all extremely inexpensive by comparison. Australia's Gold Coast has the best yacht services, however.

In May we made the crossing, with Northern California friend Chuck Hooper as crew, from Oz to the Louisiade Archipelago of southeast Papua New Guinea. During this time we buddy-boated with our dear — and newly married — friends Steve and Manjula May of the Gualala-based Farrier 41 cat *Endless Summer*. What we all remember about the Louisiades is the outstanding fishing and diving.

Our most memorable sight in the Louisiades was that of the local proas under sail. The people of the Louisiades archipelago are true watermen. Their rough-hewn sailing canoes have a main hull and one outrigger, the latter always being kept to weather. They fly a hybrid of a lateen and lug sail, and the canoes are very fast and extremely weatherly. In order to tack, the single sail is reversed,

**Something about this 3-ft clam looks familiar. The Seventh Day Adventists of PNG don't eat shellfish, leaving plenty for cruisers.**

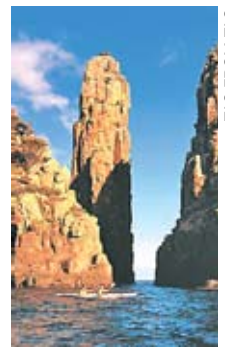

**Cradle Mountain, Tasmania, Oz.**

TAS FROM TAS



SEAL LEVEL



# CHANGES

and the helmsman moves from bow to stern. Sail is shortened by rolling it on the boom. But most of the time ballast, in the form of people or cargo, is moved from the main hull out on a platform which attaches the *ama*.



**PNG proas are crude, fast, and weatherly.**

On several occasions when the villagers saw us coming, they jumped into their canoes to come out and sail with us. Their sails are made of anything they can get their hands on — usually plastic tarps. Fuel here is very expensive in the Louisiades, so the tradition of sail lives on from necessity. But it's a wonderful thing to see.

It was in the Louisiades that we met up with fellow cruisers Adam and Leonie, and their two young boys, on the Dutch monohull *Elena*. We'd crossed the Pacific with them, but hadn't seen them since New Zealand the previous year. Our arranged meeting took place in Buka, which is on the northern end of Bougainville Island. There is still plenty of political turmoil on the island, so we heard gunshots during the night. It reminded us of when we lived aboard in Vallejo. Other than trying to kill each other, the people were extremely friendly. We only hope they can resolve their differences without further bloodshed.

Our three boats — *Elena*, *Endless Summer* and *Sea Level* — then started our journey north and west to the outlying islands across the top of New Guinea and Irian Jaya. This route is not much traveled by yachts, so we and the natives

**If you're going to reprovision in Indonesia, Bali is one of the better and easier places to do it. But English is not widely spoken.**

we encountered were equally curious about each other's lifestyles. Other than our traveling companions, we didn't see another cruiser until the island of Ambon, three months after leaving Australia!

*Endless Summer* then headed up to Palau from the Hermit Islands, while we and *Elena* continued on toward Bali. Our route over the Bird's Head Peninsula took us through Raja Ampat, more specifically to the island of Kri. There we met Max Ammer ([papua-diving.com](http://papua-diving.com)), who runs a dive resort and is a wealth of information on the whole area.

Of Dutch descent, Max came to the area 40 years ago to dive on WWII wreckage. But he fell in love with the place and never left. Max puts a lot of effort into not only protecting the area, but training the locals how to deal with us outsiders. We spent a week at his resort diving on what some experts claim is the best diversity of coral on the planet.

We and *Elena* spent the following month meandering down through Indonesia, where we eventually made it to Bali. Leaving our boat on a mooring, we returned to the States for two months to visit family and friends.

As anybody who has been to Indonesia can attest, the bureaucracy can be a nightmare. To get a CAIT — the cruising permit — and all other such paperwork services, we highly recommend Ruth and Nathan of [islemarine.com](http://islemarine.com) in Serangan Harbor at the Bali YC. These are truly two of the most helpful and professional people we have had the good fortune to work with.

Back to the present. So much for best-laid plans. The winds that were supposed to be light and help us move to the west along the south coast of Sumatra were replaced by the northwest monsoon. We ultimately had to tuck our tail between our legs and head for Singapore. We passed right by Krakatau volcano, which is famous for exploding in 1883 with a force equivalent to 10,000 times that of the atomic bomb dropped on Hiroshima! At least that's what the guide book says. At the moment, we're enjoying a nice spinnaker run up through the Sunda Strait between Java and Sumatra. We should be in Singapore before long.

The cost of cruising Indonesia has been similar to the cost of cruising in Mexico, but provisioning is not as



easy. Alcohol is very expensive — when you can find it. To our knowledge good wine can't be found in Indonesia. Beer is easier to come by than spirits, but it's not as cheap as in Mexico. Resupplying with fuel is much more difficult, and the bureaucratic paperwork is over the top! Just as in the bad old days of Mexico, you're expected to check in at every port of call.

Anchoring is more difficult because most anchorages have more coral and less sand on the bottom. The Indonesian surf is some of the best in the world, but most of it breaks onto coral, so it's a bit risky for an old longboarder such as myself. The diving is so fantastic, however, that it alone would justify a visit. The locals are all very friendly, but learn some Indonesian before you arrive because English speakers are rare.

Indonesia has 17,000 islands, and most have natural wonders or interesting ruins. A cruiser could easily spend

SEA LEVEL





# IN LATITUDES



ALL PHOTOS COURTESY CURARE

*'Curare', the Goodalls' Bowman 36, on the hard in Valdivia, Chile. Unusually, the couple — seen at Loreto Fest in the upper left inset — didn't continue across the Pacific after Easter Island, but headed to South America. Lower left inset; One of the spectacular sunsets in western Panama.*

numerous seasons in Indonesia, and explore a different island every season. Services for yachts are few and far between, however. We feel blessed to be able to tour such a fascinating country. Nonetheless, West Coast cruisers might be interested to know that our favorite cruising areas are still Mexico and British Columbia. We look forward to cruising both of them again sometime.

— jim and kent 01/06/12

## **Curare — Bowman 36 Geoff and Linda Goodall Cruising to Southern Chile (Vancouver, B.C.)**

We started 2011 by crossing the Gulf of Panama on New Year's Eve, and spent a few days in Las Perlas islands before moving on to Panama City. What a dynamic and entertaining place! Anything

seems possible, and every imaginable boat repair can be accomplished. Within a week we had our liferaft inspected, the radar/chartplotter repaired, and parts and batteries flown in from Miami, and got new charts for heading farther south. The best entertainment, of course, was watching all of the cruisers preparing for or finishing off their Canal transits, with all the tires hanging from every stanchion.

The highlight of last year's cruising was our 950-mile sail southwest from Panama's Las Perlas islands to the Galapagos. We kept in radio contact with five other boats, and all of us experienced the idyllic conditions of broad reaching in 15 to 20 knots of wind. We even had favorable current.

So we covered the nearly 1,000 miles in seven days, most of it under spinnaker. *Curare* even turned in her best 24-hour run — 180 miles. The five boats arrived at the Galapagos within 20 hours of each other, and all of us agreed it had been the sail of a lifetime.

After a week at anchor off Santa Cristobal, and observing as many of Darwin's creatures as we could, we set off for Easter Island, 2,200 miles to the SSE. We again had reasonable weather on this passage, making the trip in 19 days. Although there is no secure anchorage at Easter Island, we did manage to get our dog Jessie ashore for some much needed exercise.



*Jessie and Geoff at Easter Island.*

We made a quick trip around the mysterious island before the winds started building in the Hanga Roa anchorage. But we were too late to leave, so we ended up riding out a three-day blow with winds to 25 knots and seas in the 15-ft range. The experience was all the more thrilling because a singlehander with a partially disabled boat managed to anchor, with the assistance of the Armada, upwind of us. Later that morning one of her anchor rode parted. Fortunately, two cruisers came to her assistance and managed to secure her with a second line and anchor.

After provisioning with fresh produce at Hanga Roa, we departed for the 2300-mile trip southeast to Valdivia, Chile. We had some contrary winds, a gale and periods of calm, so we averaged only 100 miles a day. We tried to avoid get-

*Geoff and Linda had a good trip from the Galapagos to Easter Island, but nothing like the idyllic one from Panama to the Galapagos.*



CURARE



# CHANGES

ting below 40 degrees latitude, but had to duck one weather system that took us to 42 degrees south.

Valdivia, a lovely city nine miles inland with a population of 150,000, has been a comfortable place for us and our boat, something the Spaniards figured out back in 1550 when they made it their Pacific Coast hideout. We enjoy trips into town, where we can get a four-course meal with a glass of fine Chilean wine for just \$4, and salmon for \$2.75 a pound. With the fresh produce from nearby,



Valdivia YC docks.

provisioning is excellent.

We arrived at the Valdivia YC in May, returned to Canada for some time, and are now at Marina Estancila near Valdivia, where I've been working on maintenance tasks for the past several weeks. As it's the austral spring heading toward summer, we're in no hurry to move on. The weather has been great and is expected to get even better, and there is so much coast to explore.

During our time in South America, we took the opportunity to do some inland travel. We visited the 12,000-ft-high altiplano of landlocked Bolivia, where the air is thin, crisp and clear. The salt flats at Uyuni are the largest in the world, and home to large flocks of pink flamingos. Lake Titicaca, at the border of Bolivia and Peru, is the largest high-altitude — 12,500 feet — lake in the world. It's the birthplace of the Aymara Indians, who were overtaken by the Inca. Transportation throughout the region was easy by car, plane, bus — and even boat.

We can't really comment on cruising

**For a change of pace, the Goodalls visited Lake Titicaca, the highest lake in the world and Tristan Jones' old stomping grounds. Brrrr.**



TITICACA TOMM

in Patagonia, but will have more to report in two months. Right now the Valdivia YC, the largest in Chile, is getting ready to host the World Cup for Pirat (sic) class 5 Metre boats. Over 70 entries and 300 sailors from all over the world are expected. It looks like it's going to be fun.

— geoff 01/05/12

## **Pacific Breeze — Spronk 78 Cat Guido Polko and Stefanie Ender Four Weeks Cruising Greece (Sausalito)**

I arrived in the Greek industrial city of Thessaloniki on August 22 to meet my friends Captain Paul, from Germany, and Dada, his Bosnian wife, aboard their Spronk 78 catamaran. The plan was that I would join the former Heidelberg restaurateurs to diplomats for two weeks of cruising in the Greek Isles, at which time we'd be joined by my girlfriend Stefanie in Athens for an additional two weeks of sailing pleasure.

Scores of Spronk catamarans had been built in the Caribbean over the last 30 years, the publisher of *Latitude* informed me, and they all had a curious feature the designer had insisted on — heads that consisted of a toilet seat atop an open hole into the ocean! Needless to say, *Pacific Breeze*, which had just come out of a \$1.5 million refit, and which caters to \$60,000/week charter clientele, has a more sophisticated waste disposal system.

After a wonderful welcome that included fine wine, a delicious dinner and wonderful conversation, the three of us departed the next afternoon for the Sporades. Located in the northwest Aegean about 150 miles south of Thessaloniki and about 120 miles north of Athens as the crow flies, the Sporades are among the most beautiful — and green — Greek Islands. They also feature many great places to anchor and explore. We enjoyed a lovely evening sail, although we had to keep our eyes out for fishing vessels, as Greek fishermen either don't know or don't care about showing the proper lights. We even saw some boats with pink and blue running lights.

At midnight we arrived at Nea Moudania, where Paul set double anchors. Perhaps because he's German, Paul always sets two anchors, and sometimes a stern anchor. That way he



can enjoy a good night's sleep even if the wind shifts. German tradition dictates that after anchoring, everyone partakes in an *Anlegerbier* — which literally translates as 'pier-beer'. It's an excuse for the first beer of the day or night. We didn't break with tradition during our time in Greece, and enjoyed many a delicious Mythos beer.

We awoke to a typically beautiful August day: 87 degrees with lots of sun and blue skies — and a 20-knot *meltemi*. The *meltemi* is the dry north wind of the Aegean Sea that is caused by a combination of high pressure over the Balkans and low pressure over Turkey. *Meltemis* can be dangerous for sailors because they come up in clear weather, sometimes without warning, and because they can blow up to 40 knots. But this *meltemi* stayed around 20 knots, so with the big chute up, the long, lean cat effortlessly covered the 90 miles down to Skiathos town. We were often visited by leaping dolphins, which made the passage all the



# IN LATITUDES



**Having designed, built and raced catamarans in mostly the Caribbean for more than 40 years, Peter Spronk had a huge influence. 'Pacific Breeze', like most of his designs, had very narrow hulls and surprisingly low freeboard. Unlike most Spronks, 'Pacific Breeze' has modern marine heads.**

more enjoyable.

Despite the huge size of the cat, Paul and I basically did all the sailing. The genoas are on electric furlers controlled from the cockpit, and even the daggerboards can be raised or lowered from the cockpit. The only hard part is having to let one running backstay off and put the other one on when gybing or tacking. We flew an asymmetrical chute on a roller furler without using a pole.

When we arrived in the late afternoon, Skiathos town appeared to be a pleasant, sleepy little place. The terror started at 11 p.m., as that's when the loud — and I mean *really* loud! — music erupted at a couple of the clubs. The music was so loud that earplugs offered no relief. We were honestly audio-tortured until the music stopped at 5 a.m. Our advice is to never spend a night on a boat anywhere near Skiathos town — or any of the oth-

ers where music is allowed to blast like that until dawn.

After such a dreadful night, we wanted to leave at first light. Alas, we couldn't get our primary anchor — a huge aluminum Fortress fluke model — off the bottom. We tried everything to bring her up, but to no avail. Not wanting to spend another God-awful night at Skiathos town, not wanting to lose the primary anchor, and not being able to reach the anchor by free-diving, Paul tracked down a diver.

Theo, like all the Greeks we met, was friendly and helpful. And he immediately found the problem. Our anchor chain, not our anchor, was trapped beneath a huge old anchor, and there was no way we could get it back up without additional help. Paul decided that we had no choice

but to cut the anchor free of the chain. We were able to get the anchor and the anchor end of the chain up onto the boat, at which time I used a power grinder to cut the chain off at the anchor. You should have seen the sparks fly! We had to leave 330 feet of high-quality German chain on the bottom, but Theo promised he'd get it up later and contact us. He was true to his word, so after stops at a few other places, we returned to Skiathos to pick up the chain. Theo's bill of \$500 wasn't cheap, but it was less expensive than having to buy replacement chain.



**Better on the boat than on the bottom.**

Free once again, we took off toward Skopelos in 30 knots of wind and swells to 15 feet. These were the kind of conditions that *Pacific Breeze* loves, and we hit speeds of up to 18 knots. It was a far cry from what our Ericson 27 back in Sausalito would have done in the same conditions. (By the end of our trip, Stefanie and I would go over to the dark side of sailing. Our next boat, especially for cruising, will be a catamaran.)

Boats in Skopelos moor Med style, which means you put your stern into the wind by setting the anchor, then backing up to the quay. I expected that the strong winds would make it difficult for the 78-by-35-foot cat, but *Pacific Breeze* didn't have any 'prop walk' to complicate the matter. We enjoyed a lovely day in town and a nice dinner at a local's place in the old town.

After enjoying some other spots, we needed to get to Athens quickly in order

**Guido and Stefanie in Greece last summer. He got the better deal, as he spent a month, not just two weeks, aboard 'Pacific Breeze'.**



COURTESY PACIFIC BREEZE

PACIFIC BREEZE



# CHANGES

to pick up Stefanie, who was flying in from Sausalito. We decided we'd take the 120-mile channel between the Greek mainland and the big island of Evia. Boats headed north into *meltemis* often use this channel rather than the open Aegean, as it's more sheltered. But even

if you were headed south, as we were, the scenery in the channel is more beautiful. You can always count on the wind blowing out of the north in the summer. Well, almost always, as we had wind out of the southwest, meaning on the nose.

We had a nice sail, but we had to Med-moor for the night at the little town of Atalani, where there were nothing but small restaurants for locals. We enjoyed our dinner, but were surprised by the cost of the fish. They charge by the kilo in Greece, and it's always in the range of 60 to 80 euros, which means it was \$30 to \$50 a pound!

The most interesting feature of the channel is the 'sliding bridge' at Chalcis at the southern end. The sliding bridge — similar to the one in Barcelona — retracts the roadway from over the narrows and allows boats to pass. The current is very strong in the narrows and is said to reverse itself every six hours. Legend has it that philosopher Aristotle became so frustrated with his inability to understand the currents that he threw himself off one of the ancient bridges in frustration. If the story is true, he's lucky to have survived, because many others

**One unfortunate thing about Greece is that the fish are as small as the price for them is high. A side of veggies would be nice, too.**



**Big sloop-rigged boats mean towering masts.**



PACIFIC BREEZE

have drowned doing the same thing.

The bridge is only open for about one hour at about midnight, and this is something of an event. Because we were on such a big cat, people assumed that we were VIPs, so we were the focus of much attention and waving. It happened many other places, too.

The next day we picked up Stefanie and brought her to the boat at somewhat quiet Porto Rafti. She'll take up the story of the last two weeks of our adventure in the next edition of *Latitude*.

— guido 10/15/11

## **Rascal — Hallberg-Rassy 53 Henry Mellegers, Glenys Henry Malaysia's Raja Muda Regatta (Oakland)**

What's the best way for cruising yachts to make part of the passage north up the Malacca Strait in mid-November to begin the cruising season in northwestern Peninsular Malaysia and Thailand? We nominate the Raja Muda Regatta, which is organized by the Royal Selangor YC of Malaysia, and takes the fleet from Port Klang (Kuala Lumpur) up to the big cruising center of Langkawi via the islands of Pangkor and Penang.

Our nomination is based on the experience we recently had crewing aboard Gavin and Carol Welman's Langkawi-based *Rascal* for a 10-day, 300-mile sail. It included six races, three of them passage races of 90, 60 and 55 miles, and three 25-mile day races held in Penang and Langkawi harbors.

And guess what? We won our class, taking every race except for the one we'd gotten mixed up with a lay day. Our crew consisted of Gavin the skipper, Carol the Admiral, an old British Navy guy named Tony, and the two of us. The average age of our crew was 63, and we had more than 180 years and 250,000 miles of sailing experience. There's something to be said for us old farts with grey hair!

We met *Rascal* at the Royal Selangor YC in Port Klang after a long and convoluted trip from our Cal 3-46 *Dream Catcher* in Singapore. We had a lot of fun in Port Klang — the regatta organizers see to that at every stop — but were disturbed by the staggering amount of plastic and other garbage that flows down the river. There were islands of it, and it was not attractive.

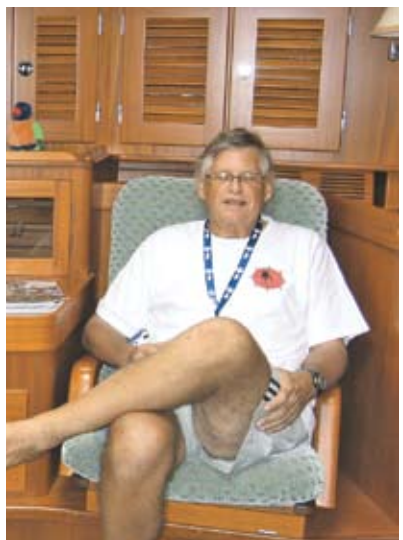

The first race was an overnighter to the funky seaside town of Pangkor. After some nice sailing, the wind died. Boats are allowed to use their engines in the Raja Muda, but pay a steep penalty for doing so. Our skipper elected to gut it out. It was a smart decision, as the wind returned and we kicked butt.

We loved Pangkor. Although it's the center of the sardine fishing industry, it nonetheless has a pretty anchorage flanked by wooded hills. After a delicious lunch, we took a walk through the fishing boat harbor. There we saw women sitting cross-legged, sorting the millions of sardines by hand — and one cat who had his choice of more sardines than he could eat in a lifetime. After they are air-dried, sardines are called *ikan bilis*, and are a key ingredient in many Malay dishes. Anyway, the party and prize-giving were great, and a bit of rain made life less dangerous for the fire eaters.

The second day was the second passage race, this one to the 60-mile-distant island of Penang. After a delay due to



# IN LATITUDES

start, but at the wrong time. Fortunately, the headstay on the boat of our main competition failed, leaving us still in the hunt for regatta honors.

We kicked butt in the final race to win our class. By this time we were wearing, but it didn't stop us from partying at the Royal Langkawi YC for the final prize-giving shindig.

We had a leisurely breakfast after the regatta, then took the boat back to her homeport at Telaga Harbour, which Gavin claims is the prettiest marina in the world.

Winning our class was a substantial thrill. As Henry and I have now done five Phang Na regattas in Thailand, one King's Cup also in Thailand, and one Raja Muda in Malaysia, we're now thinking of entering our Cal 46 *Dream Catcher* in the Raja Muda next year. Anyone want to crew?

By the way, my overview of cruising in Southeast Asia, which was slated for this issue of *Latitude*, will appear in the March issue. If cruising an inexpensive area with many rich cultures appeals to you, be sure to check it out.

— glenys 12/19/11

## Cruise Notes:

Having read Guido Polko's *Changes* this month about fish costing \$60 to \$100 a pound in restaurants during his cruise in **Greece** last summer, we couldn't help comparing it with the cost of food in the **La Cruz - Punta Mita** area of Mexico. Yesterday a friend bought a fresh snapper to feed four from the **pes-**  
**Fish is a little more expensive at the market at the La Cruz Marina than direct from the pescadors in Punta Mita, but it's still a bargain.**

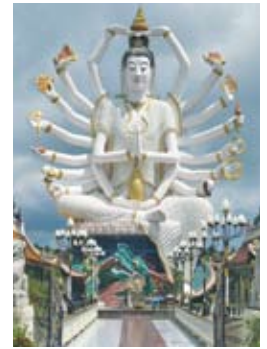

**Multicultural Malaysia has a different look than Mexico.**

PHOTOS COURTESY DREAM CATCHER



**Scenes from a Raja Muda Regatta in Malaysia, starting from top right. Henry and Glenys of the Oakland YC-based Cal 3-46 'Dream Catcher'. Raja Muda conditions vary from light to heavy. Henry luxuriating aboard 'Rascal'. Malaysian women sorting sardines. Temple House of the Khoo Clan.**

light winds, we sailed hard through the night until 3 a.m., and once again took our class. Trying to find the flashing lights of the finish line against the brightly illuminated city of Penang was a challenge, as was motoring two hours upriver past countless hazards to reach the new Straits Quay Marina.

I had last visited Penang in the early '70s, and my goodness was I shocked at the changes! It now has a population of 1.5 million and countless high-rise condos and office buildings, all against a backdrop of big hills. Penang is a melting pot of Chinese, Indians and Malays, so it presents a diverse architectural face of Burmese temples, decrepit shop-houses, grand colonial homes, and flashy condos. The venue for the second race prize-giving was the amazingly ornate Chinese temple that is the clan house for the Khoo Clan.

When the start of the next race was

postponed, Admiral Carol, a black belt foodie, got out the smoked salmon, wine and cheeses, and made an elegant lunch with a fabulous salad. We had some spinnaker misadventures when the race finally started, and with the wind gusting to 27 knots, it was good we got it down and kept it down. During the more anxious hours in the middle of the night, Carol, who was standing in the cockpit, was struck by a fish! After a rip-roaring sail, we crossed the Langkawi finish line at 11 p.m., victorious again. It was late, but not too late for some French champagne and a late dinner onboard.

While setting off for town the next day for lunch, someone asked why we weren't headed to the starting line. Somehow we got confused about the lay day! We managed to get a great



LATITUDE/RICHARD



# CHANGES

**cadors** at Punta Mita. It cost \$2, or 50 cents a serving. We just got back from Sayulita, where we enjoyed a large breakfast mole taco and a chicharrón taco from a **taco cart** run by a couple of sweet older *mujeres*. The total came to \$1.50, including all the garnishes and secret sauces. On Wednesdays and Fridays you can get mouth-watering shrimp,



De Mallorca loves the 50-peso tortilla soup — and view — at the yacht club.

**Tacos or Tacos on the Street**, also in La Cruz, you can get tacos with all the trimmings — plus have a great chat fest with other cruisers — for about \$1 a taco. Three bucks and you're stuffed. And there's no corkage fee when you bring your own wine — which you'll want to do. The special breakfast at **Octopus' Garden** in La Cruz that includes coffee, orange juice, eggs, bacon, sausage, beans and bread is less than \$6, and you get to enjoy it in a garden setting reminiscent of Mallorca. And on Saturday mornings, you get terrific live music, too. Many other places offer breakfast specials for under \$3. Other favorites are the fabulous **Como No?**, and **Casa de Pinter** in Punta Mita. The list of wonderful places to eat inexpensively goes on and on. Just ask any cruiser.

**Jeff Heald and Abdon Legrand, who owned a home decor and gift shop in Sacramento for 20 years, now run the very popular Como No?**



BALTIC YACHTS

On too tight a budget to splurge so extravagantly on dining out? Or want to make sure you get plenty of veggies in your diet? We recently swung by a local *bodega* — they're on every other corner — and picked up two tomatoes, a big avocado, two zucchini, and two cucumbers for less than \$1.70. As we recall, that's just a tad less than it all would have cost at a Whole Foods in the States. If we'd picked up half a cabbage for less than 50 cents, we could have made a big salad or, after adding lentils, a killer soup. Booze and food in fancy tourist restaurants naturally shatter a cruiser's budget, but the less expensive places usually seem to be more fun and often have better tasting food. Thirsty? Corona and other beers sell for less than \$1 a bottle when bought by the case and even in some restaurants.

Thirty-one boats from 12 countries — including eight from the United States — departed St. Lucia on January 8 on the 15-month, 26,000-mile **World ARC Circumnavigation**, hosted by World Cruising Ltd. Eight other boats, five of them in Panama, are expected to join the fleet for at least part of the adventure. Ted Bainbridge and Bernard O'Hanlon's Australia-based Beneteau Oceanis 393 **Glamorous Galah** is the smallest boat in the fleet, while **Sapphire II**, John O'Connor's U.S.-based Discovery 67, is the largest. The fleet includes five catamarans, three of which started in St. Lucia, the smallest being Steve Spracher's U.S.-based Lagoon 380 **Southern Cross**; the largest is Phil May's France-based Catana 52 **Fantasia**. The event is a combination of organized stages and 'free cruising'. Entry fee for the entire event, which includes Canal fees and Galapagos permits, runs from \$18 to \$19.5k. If anyone would like to join the event in progress, they can do so in Australia for between \$10.5 and \$11.25k. In recognition of the ongoing troubles in the Arabian Sea, the fleet will

go around South Africa's Cape of Good Hope and up the South Atlantic to Rio for Carnival and to the St. Lucia finish rather than via the Red Sea, the Med and the North Atlantic.

Government mischief all over the cruising world? You bet. Let's start in **French Polynesia**, where authorities are beginning to make spot checks to make sure all arriving cruisers have



— **health insurance**?! *Mai oui!* Apparently it's an old legal requirement they've dusted off to promote tourism — just kidding — and are starting to enforce. Admittedly, it's understandable that a lightly-populated tourist area doesn't necessarily want to pick up big medical bills for visitors. If you can't prove you have health insurance, you're subject to being forced to leave or denied entry to French Polynesia. But we haven't heard of anyone who has gotten the boot so far. *A santé!*

Although we're not endorsing it, one of the better health insurance options might be to get coverage from **Divers Alert Network (DAN)**, a highly-regarded non-profit organization established long ago to provide limited-duration health and medevac insurance for divers traveling to the far reaches of the globe. Rates are said to be reasonable.

And down in San Diego, there's been a big hubbub about **Mexico** supposedly now requiring visitors by sea, and even



# IN LATITUDES



VISIT ITALY NOW

**Sure, the east coast of Italy has its spectacular spots. But as they say, 'there are lots of fish in the sea', particularly when it's the Med Sea.**

those coming within 24 miles of shore, to obtain **visas in advance**. There's a lot of confusion about the new law, and it's beginning to look as though it's only intended for folks on the commercial fishing boats. As Bob Hoyt of Mag Bay Outfitters told *Latitude*, the visa fees are not unreasonable, as U.S. fishermen cross into Mexican waters to take lots of fish. Only time will tell how this all plays out for cruisers.

Then there's **Italy**. Having pissed away their treasury and gone into unsustainable deep debt — sort of like the Golden State — the Italian government has come up with an 'austerity measure' that is more accurately a big **new tax on Italian and foreign yachts**. A tax we suspect is going to drive the beautiful but beleaguered country even further into the fiscal hole. According to the British Cruising Association, starting on

May 1 — just before the beginning of the high season — all yachts in Italy will be subject to a new daily tax. It comes to \$312/month for 37- to 42-footers, \$390 a month for 43 to 53-footers, and over \$1,260 a month for 58-footers. It's unclear if Italian legislators realize that boats, particularly foreign boats, can simply throw off their docklines and leave Italy and Italian taxes in their wake. After all, as wonderful — and expensive — as places such as Portofino, Capri and Sardinia are, it's only a short distance to the wonderful cruising attractions in France, Spain, Croatia, Greece, Malta and Tunisia, where either there aren't any such taxes/fees, and/or they aren't anywhere near as high as Italy's. And, we might add, where there aren't any chickenshit captains fleeing cruise ships after holing them on reefs.

Who would get hurt, for example, if **Profligate** was in Italy on May 1? Not us, because we'd take our catamaran and the

\$1,260 a month we would have had to pay in tax to a less punitive country. No, the ones who are going to get hurt are the Italians who are no longer going to have jobs in the boatyards, chandleries, waterfront bars and restaurants, and travel industries. Which means the Italian treasury takes a hit, too.

In years past, **Dockwise Yacht Transport** has been a popular — albeit



LEONARDO

**Less boats means less euros for Italy.**

pricey — way for cruisers to get their boats from Mexico to British Columbia in the late spring. Dockwise is no longer offering that service. Be advised that in any event, yacht shipping schedules are not something that can be guaranteed.

We had hoped to put our Olson 30 **La Gamelle** aboard a **Yacht Path** ship from Port Everglades to the U.S. Virgins in mid-January. Alas, it turns out that Yacht Path won't have a ship to the Virgins until at least March, which screws up our plans and is going to cost us some bucks. Had we known, we could have just as easily gotten *La Gamelle* on their December ship. We nonetheless appreciate the problems shipping companies have with loads and schedules, and just want potential customers to be forewarned.

Like all great adventures, the *La Gamelle* one is having all kinds of unexpected twists. It's now very likely that the boat will be shipped to Martinique on Dockwise, after which we'll single-hand her to St. Barth via Dominica, the Saints, Guadeloupe and Antigua. That's 220 miles of close- to beam-reaching in the Caribbean trades, which might be a whole lot better than 120 miles of beating into the trades from St. Thomas to St. Barth. It could be fun.

**'La Gamelle', in the slings and in limbo in Port Everglades, Florida. Her ship didn't come in, so her next stop may be . . . Martinique?**



LEANDREO NAPOLEANO



# CHANGES

By the way, a special *Latitude* thanks to Seattle-based Gerald Dudley of **Dudley Yacht Transport**, who really came through for us in a pinch after another trucking company failed to honor their commitments and at the last minute tried to jack the price by 33%. Two days later they were calling back begging for the business. Gerald, by the way, told us he's getting his 70-ft sled, the old TransPac-winning **Drumbeat**, ready for a South Pacific cruise. He'll have some karma going with him.

A group of North American cruisers enjoying New Year's fireworks over London's Big Ben? It sounds crazy, but it's true.

"*Latitude* has fueled our cruising dreams from way back when we lived in Des Moines, and the publisher's commentary on all things has guided us well over the years," report Ed and Sue Kelly of the Catalac 36 cat **Angel Louise**. "As planned, we're berthed for the winter at St. Katherine Dock, which is next to historic Tower Bridge in London. We actually have a contingent of 10 North American cruising boats in the marina.



ANGEL LOUISE

**An unusual cruising view: Big Ben at precisely midnight Greenwich Mean Time, as the new year moved into the western latitudes.**

We're loving our great 'after retirement retirement' cruising life."

"I had a wonderful solo sail from Majuro in the Marshall Islands to Fiji's Savusavu, with brief stops at Kiribati and

Tuvalu," reports Jim Coggin of the Richmond-based Schumacher 40 **Auspice**. "Three key factors made it a highly enjoyable experience for me. First, having a well-found, high-performance boat. Even utilizing a conservative sail plan — i.e. "reef early and reef often" — she rarely sailed at less than six knots no matter the point of sail. As measured by noon-to-noon positions, with the wind forward of the beam the entire trip, *Auspice* averaged just over seven knots. The second factor is being well rested. I'm not the kind of guy who enjoys a passage trying to get by on 20-minute snippets of sleep, and don't think I'd make good decisions if I were sleep deprived if the shit hit the fan. So I rely heavily on AIS, radar, the radar detector, the radar reflector, and VHF to be additional eyes and ears. I try to sleep solidly during the day so I can be alert most of the night. My biggest worry isn't big ships, but rather the smaller vessels with nobody standing watch. There's nothing that can be done about semi-submerged containers. I just have to trust my luck. But I carry an EPIRB,

**EL CID MARINAS MAZATLÁN-CANCÚN**  
**MÉXICO**  
**FIVE STARS FULL SERVICE MARINAS**  
[www.elcidmarinas.com](http://www.elcidmarinas.com)

Mazatlán: [marinaelcidmazatlan@elcid.com.mx](mailto:marinaelcidmazatlan@elcid.com.mx)  
 Cancún: [marinaelcidcancun@elcid.com.mx](mailto:marinaelcidcancun@elcid.com.mx)

**Buy our 100-watt Mariner's Package**

**and we'll pay the tax and throw in a FREE solar lantern!**  
*Offer valid thru March 31, 2012*

[www.southboundsolar.com](http://www.southboundsolar.com)  
 (503) 490-3305



life raft and satphone just in case.

"The last key," Coggin continues, "is having the patience to wait for the best weather window. Being on a schedule, real or imagined, has induced many a mariner to leave port too soon and then have to pay the price. Knock on wood, my wife Kim and I have been lucky in all our passages in the South Pacific. We recently did the feared 1,100-mile Fiji to New Zealand passage. We enjoyed 15 knots on the beam for the first five days, but then the breeze built to a bit of a gale for the last 36 hours. Not bad. While I enjoy good company aboard, I also find it delightful to have the boat all to myself for a time. After all, it means I don't have to defend my sail trim, I can cook whatever I want whenever I want, and can pee over the side and fart when I damn well please. While I hope that my wife Kim and I can share many more offshore miles, I will always look forward to chances to sail solo in the tropics."

ShantiAna Bartlett of the San Francisco-based Columbia 38 **ShantiAna**, is the latest to tell us about the new marina

in Topolobampo, which is 200 miles north of Mazatlan. "It's a small marina affiliated with Marina Palmira in La Paz. There was only one other sailboat in the marina when we were there, and maybe 10 small fishing boats. The staff is wonderful and the security great. We checked in with the port captain eight days after arriving — oops! — by calling him on the phone. He came down, looked at our crew list, and that was it. No fees, no copies, no *nada*. There is fuel close to the marina, but no pump-out station. They told us to just pump our waste into the marina. What?"

"Bill and I came to Topolobampo to do the train trip to **Copper Canyon**, which is seven times bigger than our Grand Canyon," continues Bartlett. "Mexico's only passenger train actu-



**The 70,000-square-mile Copper Canyon National Park makes the Grand Canyon seem like a relative pothole. But it's a 14-hour train ride.**

ally starts in Los Mochis and ends 14 hours and countless mountains later in Chihuahua. Thanks to the 126 bridges, 87 tunnels, and a 360-degree loop of an entire mountain, it only took 100 years to complete. As you can imagine, the scenery is spectacular! We continued on to the town of **Creel**, which is at 7,800 feet. Every home, store, hotel room and restaurant has a fire burning to keep

## Your Boatyard in the Heart of Paradise



Large, fenced, secure dry storage area

**Tahiti Customs policy has changed!**  
Foreign Flag vessels can stay on dry storage in our yard for up to 12 months out of 24.

### Our Services |

#### HAULOUT

- Marine Travelift 25 tons
- Marine railway 120 tons
- Storage in adjustable steel cradles
- Fenced Yard

#### PAINTING

- Topsides, hull, bottom, varnish
- Brush, roller, spray

#### MECHANICAL WORK

- Inboard, outboard, diesel, gas
- All brands

#### REPAIRS

- Electrical repairs
- Refrigeration installation & repair
- Fiberglass & woodwork
- Welding, steel, stainless, aluminum

#### SAIL LOFT

- Sail repairs, biminis, dodgers, covers

#### STORE

- International, Pettit, Epiglass, Devoe
- Spares
- Fill U.S. gas cylinders

#### DO-IT-YOURSELFERS WELCOME!

BoatUS Cooperating Marina



Professional boatyard in the heart of Paradise



A Subsidiary of  
The Moorings Yacht Charter, Ltd.

Raiatea Carenage will make sure  
paradise is everything you expected.

Call, write, or sail in . . . we're here to serve you.

B.P. 1111 Uturoa Raiatea 98 735 Polynésie Française

Tel: (689) 600-545 ~ Fax: (689) 600-546 ~ VHF 68

Web site: <http://www.raiatea.com/carenage> ~ email: [raiateacarenage@mail.pf](mailto:raiateacarenage@mail.pf)

# CHANGES

people warm. Our room was nice and clean, had lots of hot water for showers, and cost just \$18. A great vacation from the boat."

After Jenny Halidman and Randy Ramirez aboard the Stockton-based Mariah 31 **Mystic** reported using just 12 gallons of fuel during their nine-month crossing of the Pacific to New Zealand, we asked ocean advocate Liz Clark of the Santa Barbara-based Cal 40 **Swell** about her use of fossil fuels.

"The Tuamotus are perfect for wind and solar power," she responded, "as no mountains block the trades or attract cloud cover. So in the last six months, I only had to use one gallon of gas to run my little Honda generator to supplement my electrical supply for daily needs such as lights, the reefer, the computer and music. During that same period I used less than eight gallons of diesel for *Swell's* main engine. As I'm not in a hurry, I can always wait for a favorable wind direction before I set sail for a new destination. I used the most fuel — 12 gallons of gas — for my dinghy outboard. While I row my dinghy most of the time, sometimes a girl just has to get to the



COURTESY SWELL

*Some people preach the simple life from private jets and limos. Others, like Liz, don't pretend to be perfect, but try their best to walk the talk.*

waves quickly! But I say 'green hats' off to Jenny and Randy for their truly green cruising."

"We and friends Mark McClellan and Anne MacDonald of the McCall,

Idaho-based Deerfoot 50 **Blue Rodeo** just returned from a great evening at the **Oasis Hotel** here in Santiago Bay," report Roger and Diana Frizzelle of the Alameda/Mexico-based Catalina 470 **Di's Dream**. As always, the service was fabulous. The real reason we're writing is to let everyone know that Diego, the Oasis manager, is now providing dinghy service to and from the hotel for only 20 pesos — about \$1.50 — to sailors who hail him on Channel 23. This is great news for cruisers who want to go to shore at Santiago, but don't want to go to the trouble of launching their dinghy. Contact Diego on 23 for all the specials they have during the week. P.S. It's mid-January and the water temperature is a lovely 80 degrees.

"The coldest winter I ever spent was a summer in San Francisco," is Mark Twain's famous quip about the City by the Bay. The **Vallarta Coast variation** is, "The worst winter day on Banderas Bay is better than the best summer day on the coast of even Southern California." The latter is only true, of course, if you like highs in the 80s, lows in the 60s,

**ULI**  
INFLATABLE SUPS  
**ULIBOARDS.COM**  
**760.639.1844**  
VISTA, CA

**THE RAMP**  
BAR OPEN DAILY TILL 9 PM  
Appetizers served every night till 7 pm  
(later in nice weather)  
**WEEKENDS**  
Brunch Served 9:30 am-4:30 pm  
**WEEKDAYS**  
Lunch Served M-Th 11 am-3 pm  
Fridays 11 am-3:30 pm  
Happy Hour M-F 5-7 pm  
Available for parties too!  
(415) 621-2378 | 855 Terry François St., San Francisco  
[www.theramprestaurant.com](http://www.theramprestaurant.com)  
Like The Ramp on Facebook [www.facebook.com/TheRampSF](http://www.facebook.com/TheRampSF)

**WEDLOCK, RAMSAY & WHITING**  
Marine Surveyors  
Vessel surveys,  
consulting, deliveries.  
Serving the  
Bay Area  
since 1980  
[www.norcalmarinesurveyors.com](http://www.norcalmarinesurveyors.com)  
**(415) 505-3494**

**1,000 Used Sails**  
Listed at  
[minneysyachtsurplus.com](http://minneysyachtsurplus.com)  
**We Buy Good Used Sails**  
and Marine Equipment  
**MINNEY'S YACHT SURPLUS**  
1500 Newport Bl., Costa Mesa, CA  
949-548-4192 • [minneys@aol.com](mailto:minneys@aol.com)  
"We keep boating affordable!"



uncrowded surfing in the morning without a wetsuit, tropical flat water pleasure sailing in the afternoon, spectacular sunsets at dusk, delicious \$6 dinners, and maybe a little nookie before you crash. No wonder so many cruising couples proudly say, "We're Mexicans now!"

When we write things like the above, some people think we're trying to slam California. We're not. California does have some great things to offer. Nor are we trying to oversell Mexico, which does have its share of problems. We're just trying to cite some of the reasons so many cruisers love Mexico.

By the way, the Nayarit Riviera towns of **San Pancho, Higuera Blanca, La Cruz, and Sayulita** — the latter two big favorites with cruisers — have all been designated 'magical places' by the federal government and are therefore now getting major infrastructure makeovers. That means new plazas, new central district streets free of parked cars, utility wires underground, and general beautification. The only puzzling thing is why they're doing it at the height of the tourist season.

As for the 'bad' of **Mexico**, 67-year-old Rob-in Wood of Vancouver was shot and killed during a robbery at fellow Canadian Arvid Chalmer's house in Melaque on January 3. According to Chalmers, Wood was shot when he began battling for a suitcase the robbers had taken. Jorge Luis Murillo Torres and Ernesto Manuel Esparza Leon, two 18-year-olds with a history of violent crimes, have been arrested. Wood was not a sailor, but we mention this crime because Melaque, a very popular winter destination for Canadians, shares the same bay with the cruising center of Bahia Navidad.

Even closer to most cruisers was a late-evening incident in early January when a non-sailing Canadian friend of ours and his wife — they asked not to be identified — left Philo's Music Studio and Bar in La Cruz, went around the



**Another bad thing that can happen in Mexico: boats go on the beach. Fortunately for 'Sparvero', she wasn't badly damaged.**

corner, and got into their super-duper new double-cab pick-up. As the man was getting into the driver's seat, he was assaulted by four Mexicans, one of whom struck him in the head with a gun. The man's wife ran back to Philo's and got the 20 patrons still there to help. By the time they reached the scene of the crime, her husband had managed to fight the assailants off, but was bleeding from the head, and the thieves were high-tailing it down the road in the couples' truck.



**Climb Your Mast Alone with Mast Mate**  
**Made in the USA for 20 Years**  
**Satisfaction Guaranteed**  
**(207) 596-0495**  
**www.mastmate.com**



**KATADYN SURVIVOR 35 WATERMAKER**

The Survivor is a must for all sea-going vessels and is the most widely used emergency desalinator. It is used by the U.S. and international forces. It is able to produce 4.5 liters of drinkable water per hour. These are unused U.S. government surplus.

Reconditioned by Katadyn **\$950.**  
 Compare to factory new price: \$1,995.

For more information or to place an order, please call one of our sales reps.



**Equipment Parts Sales**  
 In the U.S.: (800) 417-2279  
 Outside the U.S.: (717) 896-9110

**Sailing Elsewhere by Matt Johnston**

Matt's book was an enjoyable read. I had 'cruised' in the Sea of Cortez 12 years ago on a sailboat and relived my experiences through his eyes. He and Judy, of course, went far beyond Mexico and I eagerly read on. What a wonderful, challenging life they experienced on s/v *Elsewhere*. Highly recommend reading *Sailing Elsewhere*.  
 — from an Amazon review



**T**his is not a 'disaster at sea' story, nor a survival tale. It is the record of nine-and-a-half wonderful years spent cruising in the Pacific. We started in San Francisco with family aboard, but after Cabo San Lucas it was just my wife Judy and I. We picked our way along the Pacific Coast, through the 'Forgotten Middle' of Central America, and all the way to Ecuador and then across to the Galapagos, the Marquesas, and on through French Polynesia, the Cook Islands, both Samoas, Tonga, and finally north to the Marshall Islands. We were not on the tourist route. There are no hotels in Penrhyn or Niuatoputapu for instance. My hope is that you will enjoy this book whether you are an 'Armchair Sailor', someone who might just sail away eventually, or someone who wants to hear about strange out-of-the-way places.  
 — from Matt Johnston, the author

Available at:  
**www.amazon.com • www.sailingelsewhere.com**

# CHANGES

Philo told *Latitude* that it was the first time in the 11 years he's been in La Cruz that something like that had happened. He notes that fancy new trucks, which are worth as much as \$65,000, are extremely popular targets for thieves in Mexico. Particularly trucks with out-of-country license plates.

In less violent but nonetheless still unpleasant news, **two dinghies were stolen** from cruising boats anchored in Matanchen Bay just south of San Blas. One of them was from Rob and Kai Sanderson's Ingrid 38 **Vellavella**. "The dinghy and outboard were cabled and locked to the boat," reports Rob. "The thieves cut the lock sometime during the night while we were aboard. It was one of the few nights we hadn't shipped the engine. It's a huge bummer because dinghies are hard to come by and very expensive in Mexico. For the record, it was a '91 Achilles 8-ft RIB with oars and a '92 8-hp, 2-cycle Johnson. Despite our loss, we want all cruisers to know that we found San Blas to be a wonderful place with great people. We highly recommend a stop — just ship your outboard!"

The San Blas estuary and nearby

Matanchen Bay seem to have become a hotbed of thefts from cruising boats in the last eight months. For what it's worth, Norm Goldie has told cruisers that five outboards were stolen from cruisers last year.

From Cuba, with love. "It pleases me to invite *Latitude 38* readers to join us at the **Hemingway International YC of Cuba** in celebrating our 20th anniversary," writes our old friend Commodore Jose Esrich. "The many activities — sailing in Optimists, Lasers, Hobie Cats, as well as fun races for cruising boats, kayaks and canoes — will start in April and run through May. Among the many activities will be a sail on April 27 from Marina Hemingway to Havana's Morro Castle, a commemoration of the Tampa to Havana Race that took place in 1930." Yes, you can take your boat to Cuba, because politically the Obama Administration can't do anything about it.

"The fish management plan for **Es-piritu Santo**, the beautiful island just

outside of La Paz, is being changed to allow the full use of gill nets up to the shoreline," report the dismayed Chuck Houlihan and Linda Edeiken of the Puerto Vallarta-based Allied 39 **Jacaranda**. "This change will kill all the reef fish and also affect the sea lion population. Unlike most other places in Mexico where there is a law but no enforcement, La Paz Bay is patrolled and illegal-fishing laws are enforced. But the new plan could scuttle those efforts. We urge all readers to take just a few minutes to go to <http://islaespiritusanto.org>, make a few clicks, and express their feelings. It doesn't matter that the original deadline has passed."

In good news, Robert Gelser, 'the Mayor of Tenacatita Bay', and his wife Virginia, of the Alameda-based Freeport 41 **Harmony**, report all is well at Tenacatita, which has a great amount of sea life. And, Myron and Marina Eisenzimer of the San Geronimo-based Swan 44 **Mykonos** report the Mayor of Chemala says the little village survived hurricane **Jova** with very little damage.

Here's to hoping that **your cruising season** is going great, and that '12 will be your best year ever.

**Let Hydrovane sail you home safely.**



▲ Polar circumnavigator Adrian Flanagan.

**YACHTING** MONTHLY October 2006  
100 best bits ever

Latest ARC survey – Hydrovane again the most popular wind vane.

Totally independent self-steering system and emergency rudder... in place and ready to go.

**HYDROVANE**  
SINCE 1968

SURVIVE YOUR DREAM

**info@hydrovane.com PHONE 1.604.925.2660**

WWW.HYDROVANE.COM

Your secret paradise...



Located in a beautiful sheltered lagoon on the north Pacific coast of Nicaragua, Marina Puesta del Sol is your premier cruising destination in Central America.

- ◆ 140 foot fuel dock - diesel-gasoline
- ◆ Well marked channel entrance
- ◆ 40 slips with water, and power
- ◆ Two pools, oceanside and marina
- ◆ Tennis, surfing, fishing, horseback
- ◆ Onsite Immigration & Customs
- ◆ Full service restaurant and bar
- ◆ 24 hour security patrol
- ◆ Yacht club with showers and laundry
- ◆ Cable TV and wifi internet

**Marina Puesta del Sol**  
RESORT

\* 30% discount applies to slip fees

Aserradores, Nicaragua ◆ 011 (from US and Canada) 505-8880-0019  
info@marinaps.com ◆ www.marinapuestadelsol.com ◆ USA 408-588-0017



# JUST YOU AND THE SEA...



...and the jacuzzi,  
the 80-ft long pool, the surf,  
the Punta Mita anchorage, and the 4-mile distant  
Tres Marietas Islands

## Punta Mita Beachfront Condos

Call Doña de Mallorca for reservations!

1.415.599.5012

[www.puntamitabeachfrontcondos.com](http://www.puntamitabeachfrontcondos.com)

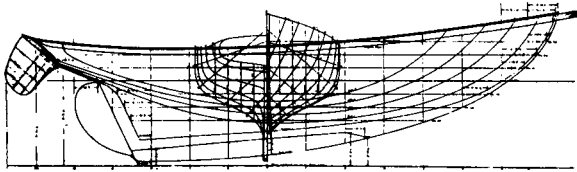

### MAKELA BOATWORKS

Family owned since 1948

Wooden Boat Building • Repair and Restoration

19280 South Harbor Drive • Fort Bragg, CA 95437

**(707) 964-3963**

email: [howard@makelaboatworks.com](mailto:howard@makelaboatworks.com) • [www.Makelaboatworks.com](http://www.Makelaboatworks.com)

**NEW AND USED SAILS!**

Specializing in production boats and featuring the largest selection of stock sails available anywhere! Save with warehouse volume discounts on Stock Sails, Custom Sails, Sail Covers, Furlers and Accessories. All top Quality.

*All Fully Guaranteed!*

- Full Batten Mains
- Furling Genoa's
- Storm Jibs
- Trysails
- Furling Units
- Custom Canvas
- Used Sails

**FAST SHIPPING!**

**THE SAIL WAREHOUSE**

Ph. (831) 646-5346 [www.thesailwarehouse.com](http://www.thesailwarehouse.com)

VISA MasterCard

**weatherguy.com**

**Worldwide Marine Forecasts**  
**Cruising, Racing & Commercial**  
Packages Starting at \$65.00 USD

(866) 882-WXGY (9949) toll free  
(808) 291-WXGY (Mobile)  
(808) 254-2525 (Office)  
(808) 443-0889 (Fax)

970 N Kalaheo Ave  
Suite C-104  
Kailua, Hawaii 96734  
[info@weatherguy.com](mailto:info@weatherguy.com)

[www.weatherguy.com](http://www.weatherguy.com)

**MARINA DE LA PAZ**  
**FULL SERVICE MARINA**

*Friendly, helpful, fully bilingual staff*

Hardwood docks • Protective piling & sheetpile breakwater  
Plug-in Internet • Dinghy landing • Cruisers' clubhouse  
Electricity • Potable reverse osmosis water • And more!

TEL: 01152 612 122 1646  
email: [marinalapaz@prodigy.net.mx](mailto:marinalapaz@prodigy.net.mx)  
[www.marinelapaz.com](http://www.marinelapaz.com)  
Apdo. Postal 290, La Paz, 23000, Baja California Sur, Mexico

Please read before submitting ad

# Classy CLASSIFIEDS

## Here's What To Do:

**Write your ad.** Indicate category. Remember price and contact info. We make final placement determination.

**Count the words.** Anything with a space before and after counts as one word. We will spell-check, abbreviate, edit, as necessary.

**Mail your ad** with check or money order, deliver to our office; **OR, for the best - and most exposure - of your classified ad...**

**Submit your ad safely online** with Visa, MasterCard or AmEx at: **www.latitude38.com**

Ad will be posted online within two business days, appear in the next issue of the magazine, and remain online until the following issue is released.

## PERSONAL ADS

1-40 Words.....\$40  
41-80 Words.....\$65  
81-120 Words....\$90  
Photo.....\$30

• Personal Advertising Only •  
No business or promo ads except Non-Profit, Job Op, Business Op

**'Trying to Locate' Ads** are for those searching for lost boats/people - not shopping - and cost **\$10 for 20 words max**

**FREE Online Ads** are for a private party selling a boat for less than \$1,000 - or gear totalling under \$1,000. (One per person; must list prices in ad.)

All ads will be set to fit *Latitude 38* standard • Re-Run Ads: Same price, same deadline

## BUSINESS ADS

**\$70 for 40 Words Max**

• All promotional advertising •  
1 boat per broker per issue  
Logo OK, but no photos/reversals  
No extra bold type • Max: 12 pt font  
Artwork subject to editor approval.  
Biz ads will not appear on website.

## DEADLINE

is **ALWAYS** the **18th at 5 pm**

for ad to appear in the next issue.

*Due to our short lead time, deadlines are very strict and include weekends & holidays.*

**Sorry, but...**

- No ads accepted by phone
- No ads without payments
- No billing arrangements
- No verification of receipt
- We reserve the right to refuse poor quality photos or illegible ads.

*Latitude 38* 15 Locust Ave, Mill Valley, CA 94941 Questions? (415) 383-8200, ext 104 • class@latitude38.com

**WHAT'S IN A DEADLINE?** Our Classified Deadline has always been the 18th of the month, and it's still pretty much a brick wall if you want to get your ad into the magazine. But it's not so important anymore when it comes to getting exposure for your ad. With our new system, your ad gets posted to our website within a day or so of submission. Then it appears in the next issue of the magazine. So you're much better off if you submit or renew your ad early in the month. That way your ad begins to work for you immediately. There's no reason to wait for the last minute.

## DINGHIES, LIFERAFTS AND ROWBOATS

**9-FT LIVINGSTON8, MODEL 9, 2006.** Emeryville, CA. \$550. Certified for 4 passengers and up to 8hp. Lightly used and in excellent condition. Very stable/easy boarding. Includes oars, locks, and SS snap davits. jhbuetto@surewest.net.

## 24 FEET & UNDER

**23-FT RANGER, 1973.** Marina Bay. \$2,800. Hood mainsail, Mercury outboard, marine head, lifelines and much more are relatively new. Halyards led to cockpit. A Gary Mull-designed masterful Bay cruiser. ruthmoxley@gmail.com or (530) 622-7671.



**J/24, 1981.** Brickyard Cove. \$8,000. In very good condition. One set of sails. Recently replaced most deck fittings and mainsheet traveler. New running rigging and halyards. Includes single-axle trailer, new 5hp Mercury outboard. Check out the website for additional photos. www.flickr.com/photos/70367995@N07/sets/72157628114491273/show. Contact mbranco55@yahoo.com or (925) 487-0588.

**24-FT FLICKA, 1983.** Alameda Marina. \$30,000. Yanmar 1GM, bronze ports, brown hull, barrier coat, teak ceilings, Hogan main & 80%, storm jib, trysail, drifter, cruising spinnaker, 120%, 140%, small dodger, Bruce 22#, all lighting LED, 2 AGM batteries, winter and summer boom tents. Contact (510) 703-7050 or flickasf@aol.com.

**J/24, 1980.** Treasure Island. \$1,500. Ex-St. Francis racer. Full set of sails: 3 jibs/genoa, 1 reefable main, spinnakers and several racing sails. Engine, PFDs, running lights. Good bones but needs TLC. Check pics. http://ow.ly/8ubX6. Contact french3368-j24@yahoo.com or (415) 287-3250.

**19-FT WEST WIGHT POTTER, 2000.** \$11,500/obo. Lightly used, too many extras to list. Includes new 2.6hp OB. Call for more info. (707) 763-3444.

## 25 TO 28 FEET



**26-FT MACGREGOR, 1988.** Richardson Bay Marina. \$4,000. Shallow 18" draft. Very clean - in and out. 5hp 4-stroke long shaft Honda OB. Marine battery, compass, depth alarm, sails and rigging in good shape. Dagger board keel with water ballast tank. More photos at http://riccosworld.com/1988mcgregor26.htm. Call Richard (415) 378-7380.

**28-FT PEARSON TRITON, 1962.** San Carlos, Sonora, Mexico. \$8,500. Modified for offshore cruising. Masthead rig with bowsprit, heavy duty mast support, hard dodger, cockpit enclosure, Westerbeke 10hp diesel, autopilot, radar, roller furling, solar panels. Ready to go! http://sancarlosyachtsales.com/sail-boats-for-sale?item=2407969. Contact (503) 342-2065 or svcoconutexpress@hotmail.com.



**28-FT ALERION EXPRESS, 2007.** Sausalito. \$89,000. *Lizbeth*. Hull #359. One of a kind, fully loaded. Seeing is believing. Bristol, fully maintained and varnished yacht. Contact Michael. www.lizbeth359.com. (415) 608-6919 or mland2@ix.netcom.com.



**27-FT HILLYARD, 1938.** Ventura. \$9,000/obo. Great opportunity to own classic English sailboat! This well maintained stout sloop is a great island boat and true example of fine material and craftsmanship. Sell or trade for nice RV. More at http://yachtsoffered.com/yachtsoffered.cfm?yachts\_listingid=1291767&returntype=3. Contact ketchwind@hotmail.com or (818) 235-6291.

## WOODRUM MARINE

Specializing in custom interior cabinetry, tables, cabinets, countertops, cabinsoles. For power or sail.

**CARPENTRY**  
Mobile cabinet shop  
Contact Lon Woodrum at:  
**415-420-5970**  
www.woodrummarine.com



## NOR-CAL COMPASS

Adjustment • Sales

Authorized Compass Repair

Hal McCormack • norcal.compass@verizon.net • Phone/Fax (415) 892-7177

## N.E. MARINE TITLE

Coast Guard documentation • Title/lien searches • Transfers • Mortgage filing • Escrow services

Local closing facility for brokers or private transactions

30 years experience of doing it right the first time

1150 Ballena Blvd, Alameda, CA • (510) 521-4925

## BOAT • LETTERING

alphaboatsue@aol.com • (510) 599-1197 • www.alphaboatgraphics.com

Creative and durable lettering and artwork for your boat





**28-FT S2 CRUISER-RACER, 1980.** SWYC, San Diego. \$19,000/obo. Great example of S2 quality. Beautiful dark blue hull, nice interior with teak and holly sole. Over \$20k in retrofit/upgrades over last several years include rebuilt Yanmar and following new items: sails, standing rigging, Harken rollerfurling, autopilot, masthead wind instrument, fresh/salt-water head system, depth gauge, DSC VHS, stereo and more. Ready to give new owner many years of service. Moving up to larger boat. Contact (858) 245-9004 or ken@oces.com.



**26-FT MACGREGOR, 1995.** Redwood City. \$5,000/obo. Clean inside and out. Centerboard has been reworked for greater strength and less play when tacking. With Yamaha 4-stroke, 8hp outboard. Neil Pryde sails are in good condition. Main, 100%, and 120% (?). Taylor Made bimini (needs new fabric). Siemens PV battery charger. Alcohol stove, Magma BBQ. (650) 208-1916 or (650) 522-7229 or oddwahl@yahoo.com.



**25-FT SANTANA 525, 1979.** Folsom Lake Marina, CA. \$10,500. Santana 525 in exceptional condition. Recent topcoat refinish, keel fairing, and epoxy bottom by dealer Morrison Marine. Includes all safety gear, large sail inventory with a beautiful main, anchor, 2hp outboard, recent running rigging, replaced main bulkheads and keel flooring. Contact (916) 343-1811 or rich.askew@yahoo.com. 8404 Sundrop Way, Antelope, CA 95843.



**25-FT PACIFIC SEACRAFT, 1976.** Red Bluff. \$35,000 w/trailer. A beautiful loaded Pacific Seacraft 25 and like-new EZ Loader trailer for sale. Boat is cruise equipped. No expense spared on this beauty. Must see! (530) 354-4885 or (001-507) 6111-6450 or vjohannesr@gmail.com.



**25-FT CATALINA, 1981.** Sausalito. \$7,500. Full main and storm main, roller furling jib, spinnaker with sock, Honda 9.9 electric start engine, Pop-Top with canvas enclosure, autopilot, 2 anchors, and more. Sausalito berth available. (650) 324-9653 or rick.wolff@me.com.



**27-FT SANTA CRUZ, 1982.** Corpus Christi, TX. \$9,900. Well equipped, ready to race. 2005 Trailrite trailer in excellent shape. Good sail inventory. High tech halyards and sheets. New stereo with XM and wired cockpit remote. VHF and instruments. Bottom stripped, barrier coated with 2000e, and painted with Trinidad SR in 2010. Sides epoxy primed with polyurethane top coat 2010. Call or email for more information. Richard. (361) 460-0120 or rwm4b@yahoo.com.

**26-FT CATALINA/CAPRI, 1997.** Tahoe. \$14,950. Fresh water boat. Diesel, wheel steering, bimini, depth, speed, autopilot (not installed), VHF, shore cable, teak cockpit table. Covers for main/pedestal/companionway. Compass, Genoa, tandem axle trailer. Boat is in great condition but needs mast, rigging, mainsail. Email tahoe.sorge@gmail.com.

## 29 TO 31 FEET



**30-FT BABA, 1980.** Berkeley. \$45,000/owner finance. Beautiful, bluewater cruiser. Diesel 70 hours. \$15k 2010 haulout: mast, re-rigged, barrier, furler jib, batteries. Teak decks, windlass, autopilot, diesel heater, bristol 6'6" interior. Recent upgrades. [http://yachtsoffered.com/yachtsoffered.cfm?yachts\\_listingid=1291697&returntype=3](http://yachtsoffered.com/yachtsoffered.cfm?yachts_listingid=1291697&returntype=3). (510) 258-4053 or jchristianlloyd@yahoo.com.



**30-FT CATALINA, 1984.** Oakland Yacht Club Marina, Alameda, CA. \$31,000. Immaculate. Fully restored, all rigging, sails, self furling jib, re-built transmission, traveler, custom built dodger, electrical, instrument panel, etc. Sails like a dream. Must see. (925) 803-4488 or (925) 895-6629 or danmariaindublin@yahoo.com.

**31-FT HUNTER, 1987.** Alameda. \$18,500. Roller furling, Yanmar diesel. Interior like new, diesel like new, Force 10 stove and oven and cabin heater, hard dodger, DS, KM, new bottom paint 2011. (510) 927-7322.



**30-FT CAPE DORY CUTTER, 1984.** Alameda. \$37,500. Well maintained. Recent E80 radar, VariProp, new upholstery, cushions and canvas. A sweet sailing boat and easy to singlehand. Lots of pictures and information at website. <http://cd-30.blogspot.com>. Contact (510) 910-2099 or mbritt@eyedocs.com.

**29-FT J/BOAT, 1984.** Redwood City Marina. \$15,000. *Smokin J*, SF Bay class champ. Main, new jib, genoa, 2 spinnakers, 4-stroke OB 6hp, all safety equipment, VHF radio. Call Rich (650) 363-1390 or rich@spinnakersailing.com. 451 Seaport Ct, Redwood City, CA 94063.

**30-FT CATALINA, 1995.** Alameda. \$49,900. Like new. Walk-through transom, full canvas including new bimini, sail and pedestal covers. Low engine hours, self-tending jib, 135 Genoa, Dutchman. Autohelm, depth, windspeed. Anchors, props. TV, DVD, microwave, hot water. Professionally maintained. Pics available. (510) 220-1952.

**30-FT CATALINA, 1984.** Berkeley. \$18,000. Great day sailer or liveaboard. Clean interior and exterior. Universal diesel, tabernacle mast, standard rig and keel. Currently in Berkeley Marina, from Santa Cruz Harbor, with 1 year Santa Cruz slip sublease available. (415) 828-1354 or arthur.coulston@gmail.com.

## 32 TO 35 FEET

**35-FT GRAND BANKS (MAGELLAN).** Sailing yacht, 1964. Best offer above 10K. Strip-planked mahogany with teak cabin sides, aft cabin, 80hp Ford Lehman diesel. New deck. SFRH covered berth-good liveaboard. Bronze fastened, lead keel. 18,000 lbs. 6'4" headroom (sailing houseboat). (562) 899-0774 (eve).

**32-FT WESTSAIL, 1972.** Richmond, CA. \$26,000. 32-ft Westsail factory finished, original Crealock layout. Pre-blisther era resin, heavy construction. Volvo 25hp MD11D installed early 80s, considerable recent maintenance investments. Some things are needed. Realistically priced at \$26,000/obo. Please, serious inquiries only. Contact (510) 222-7882 or richard.robert@sbcglobal.net.



**35-FT YOUNG SUN CUTTER, 1981.** San Carlos, Mexico. Best offer for this proven bluewater cruiser, ready to sail the world, fully cruise equipped. Designed by Robert Perry, same layout as Tayana 37. Was \$62,800. More information: <http://youngsun.squarespace.com/specs>. Contact mohrmonte@gmail.com or (970) 259-5102.

**ISLANDER 32 MK II, 1977.** Marina Village. \$11,500. New main and jib, new batteries. Recent major service on Atomic Four including new alternator. VHF, D/S. 6'4" headroom, a very well maintained stock Islander. Will consider reasonable offers. Call during business hours. (925) 284-4433 or (925) 285-1737 or davesneary@aol.com.



### RIGGING ONLY ◊ SMALL AD, SMALL PRICES

Standing and running rigging, life lines, furling gear, winches, line, windlasses, travelers, wire and terminals, blocks, vangs, and much more.

~ Problem solving and discount mail order since 1984 ~

[www.riggingonly.com](http://www.riggingonly.com) • (508) 992-0434 • [sail@riggingonly.com](mailto:sail@riggingonly.com)



### STARBOARD YACHT DELIVERIES

Over 50,000 sea miles • Pacific, Caribbean, Atlantic  
USCG Master 100 GT STCW • Power & Sail

Rick Whiting • (415) 740-2924 • [captain\\_rick@sbcglobal.net](mailto:captain_rick@sbcglobal.net)



### MARINE SURVEYS - Capt. Alan Hugenet

Accredited Marine Surveyor (since 2004) • (415) 531-6172  
Yacht Master (USCG 200 tons - International) • Port Engineer  
Yacht Manager • Delivery Skipper • Boat Handling, Navigation  
& Safety Instructor • Accepts MC & VISA



### Spaulding Wooden Boat Center

Youth Boatbuilding Program • Community Sails  
Boatworks since 1956 • We Specialize in Wooden Boats  
Become a Member! 501(c)(3)

[www.spauldingcenter.org](http://www.spauldingcenter.org) • (415) 332-3179



**33-FT CS, 1981.** Richmond Yacht Club. \$29,900. Awesome CS 33. Ray Wall design, many upgrades. New full batten main with Dutchman, Vectran/Dacron jib on Harken furler, fuel tank/system, Force 10 stove, chart plotter, VHF/wham, dodger, more. Contact (530) 448-6167 or truckesailor@hotmail.com.

**32-FT ERICSON, 1969.** Owl Harbor. \$10,000. Well built and well maintained vintage boat. Suitable for cruiser or liveaboard. New bottom paint and zincs last year. Atomic 4, autopilot, GPS, holding tank, VHF, stereo, microwave, barbecue and stove on propane system, four sails. Contact phillips.fred5@gmail.com or (209) 572-2934.

**32-FT WESTSAIL.** Pillar Point Harbor, Half Moon Bay. \$40,000. Hull #417. Teak/mahogany interior: center table/fwd locker layout. 3 headsails, 1 stay sail, 1 drifter. Perkins 4-108. Needs new mainsail and boom. Contact (650) 303-3901 or pgclausen@gmail.com.



**34-FT ISLANDER, 1974.** Santa Cruz, CA. \$25,000. Ready for cruising and liveaboard! She's in great shape with very recent haulout. Stout fiberglass hull with a classic teak trim inside and out with 5 year bristol finish. Bronze portholes, winches, chocks, and lazarette buckles. Nice set of sails - not new, but good shape. Tabernacled mast if you need it. She's not winning any races, but she'll get you there in comfort and style. Made the crossing from Hawaii once. Inside: lots of storage, propane heater and stove w/oven and broiler, fridge, freezer, great galley with deep sink and working pantry. Sleeps four. Low hours great shape Yanmar 2-cyl diesel. Contact (831) 239-6192 or waterworks3@yahoo.com.

**32-FT WESTSAIL, 1975.** Berkeley. \$35,000. Beta Marine 1505 diesel, <200hrs., SSB, Viking raft, Monitor wind-vane, GPS/radar. <http://xenotropic.net/sinamara.html>. Contact (510) 517-9217 or joe@xenotropic.net.

**33-FT RANGER.** Alameda. \$15,500. Universal diesel, Spectra H2O maker, large sail inventory, mostly Pineapple, 406 EPIRB, Force 10 propane stove and heater, windlass, wheel. This Mexico vet is ready to go again. [www.latitude38.com/features/bomRanger33.htm](http://www.latitude38.com/features/bomRanger33.htm). Email for photos sailorkh@sbcglobal.net or (510) 507-0200.

**34-FT CATALINA, 1989.** Richmond. \$34,000. Very good condition, recent engine work, and painted bottom, teak restoration, nice galley, excellent coastal cruiser or liveaboard. Bargain at \$34,000. Contact mcchill@surewest.net or (916) 791-0833.



**34-FT MASON, 1989.** Fort Lauderdale, FL. \$125,000/obo. Beautiful Tashing-built sloop. Imported by PAE in CA. 35' LOA. Totally equipped. Roomier than most 36s. Ready to sail around the world. Free slip available. [www.sugartime.net](http://www.sugartime.net). Contact (954) 815-6364 or moon@sugartime.net.

**33-FT TARTAN 10, 1978.** Alameda. \$4,500. Needs TLC. Yanmar engine-works, main, jib, spinnaker, anchor included in sale. Needs fiberglass work in mast support area. Email for photos. Contact Jayne at jayneklugs@aol.com or Glen at (510) 339-9451.

**33-FT SPAULDING, 1962.** Sausalito. \$10,000 FIRM. One of a kind, *Pegasus*, is exceptionally seaworthy and easy to sail. **SOLD**

**33-FT RANGER, 1977.** Ventura. \$22,500. Excellent condition. Refit to cruise Channel Islands, ready for Mexico. Universal diesel, new windlass, large sail inventory, inflatable, 6hp outboard, very clean, lightly used. [www.flickr.com/photos/ventura-boatdoctor/sets/72157628129538512/?share=mail](http://www.flickr.com/photos/ventura-boatdoctor/sets/72157628129538512/?share=mail). Contact (415) 602-7302 or chris@onereef.org.



**33-FT HOBIE, 1979.** Marina del Rey. \$22,000. Turbo Hobie 33 with retractable keel, many new sails, carbon boom, open transom, kelp window, outboard, LED tri-light, boat battery, autopilot, etc. Email for photos bhuffman33@gmail.com.

## 36 TO 39 FEET

**36-FT ISLANDER I-36, 1974.** Berkeley, CA. \$27,500. Survey Jan. 2011. Bottom paint, zincs, cutlass bearing - May 2011. New full cockpit enclosure and bronze tint windows, UV protection added to 2 headsails, 2 Harken #46 2-speed self-tailing winches. Farymann R30 diesel engine, radar, GPS. Contact (503) 481-9769 or cahhiway@aol.com.

**37-FT RAFIKI, 1978.** Long Beach. \$59,995. Cutter, furling, excellent shape, moving up, no teak decks, hull and topsides LP. Updated electronics, radar, depth, GPS, Auto, knot, wind, autopilot. New lower cushions, has reefer and freezer. Water heater and pressurized water system, fresh varnish always maintained. (310) 251-8860.

**36-FT ISLANDER, 1978.** Stockton. \$23,000. Documented, roller furling, 2 jibs, full batten main, 2-speed winches, dodger/bimini, reliable Perkins 4-108, 2 new batteries and charger, recent bottom paint, propane stove, VHF radio, pressure H2O, dinghy, needs cosmetic work. Contact lyricschipper@hotmail.com or (209) 609-5350.

**CATALINA 36 MK II, 2001.** Santa Cruz. \$109,000. Very Clean. Autopilot, GPS chartplotter, windlass, dodger, roller furling jib, asymmetrical spinnaker. Universal 35hp diesel under 1450 hours. Inverter, 12v refrigerator, microwave, TV with DVD player, stereo with cockpit/cabin speakers. Many extras. Magma grill, dock box, Zarcor companionway doors. Excellent transferable slip location in Pacific Yachting charter fleet in Santa Cruz Harbor. Forget the 20+ year waiting list. Enjoy it now! Email rfrankian@sbcglobal.net.



**37-FT COOPER LIMITED ED.** pilot-house sloop, 1985. Alameda, California. \$80,000. Recently back from a cruise in the Caribbean and ready for her next passage. View our web page for specifications, equipment, and pictures: <http://web.mac.com/pecahill>. Contact (530) 305-7977 or pecahill@gmail.com.

**CATALINA 36 MK II, 1995.** Alameda, CA. \$81,000. Excellent condition, includes windlass, hot/cold pressurized water, inverter, VHF, electronics, low engine hours, 15hp Johnson motor and Zodiac inflatable. (510) 523-4081 or roystark@aol.com.



**HANS CHRISTIAN 38 MK II, 1979.** Emeryville. \$97,500. Beautiful world cruiser! New 65hp diesel 2003, standing rigging 2007, barrier coat 2009, electric windlass 2010. GPS, AIS, radar, windvane, autopilot, cabin heater, HF/Ham radio, hard dodger, and much, much more. See at <http://sailsugata.com/forsale>. Email hc38@gabrito.com.



**38-FT HUGHES, 1970.** Monterey, CA. \$19,000. S&S design, built in Canada. 74 hours on near-new diesel engine, pressure hot/cold water, sound hull, no blisters. Great Bay sailer with slip available in Monterey or Moss Landing. (831) 915-4984.

**37-FT ENDEAVOUR A-PLAN, 1979.** Marina Mazatlan. \$44,500. Strong, safe cruiser, roomy liveaboard, Caribbean/Mexico vet. Extensive re-fit 2008, fully cruise equipped. Kycocera 125 solar panels, air marine wind generator, Avon 10'2" RIB, Yamaha 15, full cockpit enclosure, many extras. Contact (831) 600-7232 or nettiemont@hotmail.com.



**38-FT GAFF-RIGGED.** Centerboard yawl, San Rafael. \$35,000. Bill Garvie found drawings in *Yachting*, Dec. 1938 of gaff-rigged 38-ft centerboard yawl, designed 1892. Faithful reproduction, precisely built, *Sarah*, launched 2006. Sound, fully found, sails by Nat Wilson, Yanmar diesel. Email florencegarvie@gmail.com.

**HANS CHRISTIAN 38 MK II, 1983.** San Diego. \$45,000. Priced to sell. Email for full info at slowwind@mail.com.



### MOBILE MARINE PUMP-OUT SERVICE

\$25 per pump up to 40 gallons. Includes fresh water flush and a packet of treatment. 20% discount for regularly scheduled service.

[www.mobilepumpout.com](http://www.mobilepumpout.com) • (415) 465-0149 • [tim@mobilepumpout.com](mailto:tim@mobilepumpout.com)

boat bottom scrubbing & more . . .

415.331.SAIL [william@gotzinc.com](mailto:william@gotzinc.com) [www.gotzinc.com](http://www.gotzinc.com)

### NOR'SEA 37

Designed by Lyle Hess Built by Michael Hess of Hess Marine  
Big Brother to the NOR'SEA 27

Stout Offshore World Cruiser Cutter Rig Canoe Stern  
**NEW BUILD NOW AVAILABLE • WWW.NORSEA37.COM**

**For the best - and most exposure - of your classified ad...**  
submit your ad safely online at: [www.latitude38.com](http://www.latitude38.com).

*Classy Idea!*

Your ad will be posted online within two business days, appear in the next issue of the magazine, and remain online until the following issue is released.





**38-FT HALSEY HERRESHOFF.** Cat ketch, 1983. San Rafael. \$49,000. Fast, beautiful, easily handled liveboard cruiser. Unstayed carbon-fiber masts. Diesel. Impressive wood interior. Two sleeping cabins. Two heads one w/composting toilet. Brand new sails and Awlgrip. Extremely well equipped. Canister liferaft. (707) 254-0220.



**40-FT NEWPORTER KETCH, 1957.** Berkeley Marina. \$57,000/obo. Isuzu inboard diesel engine, 13 sails, Dickinson heater, freshly painted, beamy cushioned salon, galley, dinette, head, ample supplies, equipment, storage. Full-cushioned cockpit, bright, warm pilothouse. Contact (415) 971-0361 or (508) 776-2440 or chris@newmariner.net.

**41-FT MORGAN CLASSIC MODEL.** 1991. San Carlos, Mexico. \$93,000. Cruiser, in primo condition, ready to go. Spacious interior - must see to appreciate. Recent survey. See website for current photos, complete equipment list: <http://sailboatvagari.blogspot.com>. Contact stanstrebreg@gmail.com or (520) 825-7551.



**40-FT VALIANT 40-112, 1975.** Long Beach, CA. \$119,500/asking. Ready for immediate cruising! Pre-blister V-40 built in Bellingham, WA. Features include fully battened mainsail, roller furling jib and staysail and navigation computer. Major upgrades to all systems - high output alternator, refrigerator, 3-burner propane stove, AIS, autopilot and anchor windlass. Contact Gary Schneider. See website for more information: <http://bit.ly/vMLFzU>. Contact captaingary1@hotmail.com or (562) 212-3783.

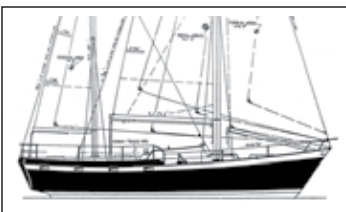

**42-FT TARTAN T.O.C.K., 1976.** \$89,900. S&S design to world cruise (great liveboard). 80hp diesel, 160 gal water, 130 gal fuel, 20 gal holding. Two companionways, 3 hatches, 17 S/S opening ports. Major upgrades. Sails, fuel system, refrig/freezer, etc. Go to YachtsOffered website: <http://yachtsoffered.com>, listing #1291773. Contact (510) 834-3261 or rfhumphrey@sbcglobal.net.



**36-FT CAL, 1966.** Richmond YC \$27,900. *Holiday*. Beautiful, strong, comfortable. Major refit including complete electrical rewiring. Refrigerator, propane stove, cabin heater, roller furling, autopilot, radar, Westerbeke diesel, electric windlass, 2011 bottom paint, too much to list. Detailed specs, photos: (916) 705-3200 or mikesrobinson@hotmail.com.

**40-FT LANCER, 1984.** Loch Lomond Marina. \$30,000. Motorsail, center cockpit, 61hp Perkins diesel, furling main and jib, spacious interior w/2 full staterooms, diesel wall heater, full galley, 1 head w/ separate vanity. Great liveboard. (415) 686-1247 or lapinlaws@juno.com.



**40-FT X-402, 1986.** San Diego. \$149,000. X-Yacht racer cruiser with Kevlar/Divinylcell hull and deck and rod rigging. Repowered (2010: 3YM30 + KM3V, all new propulsion system: MaxProp, shaft, P-strut, and PSS). New barrier coat, antifouling, and autopilot (2011). 13 good sails: complete racing and cruising sets. 2 double aft cabins, V-berth, wing berths, full cockpit enclosure, Webasto heating, 8-person Zodiac recertified (2012) life raft and hard dinghy. Contact us for visit or test sail at saltyenergy@gmail.com or (619) 955-0986.



**CATALINA 470, 2001.** Port Ludlow, WA. \$214,990. Price reduced.. Fantastic boat! 2 staterooms 2 heads, tall rig, bow thruster, electric headsail furling, in-boom full battens main with electric winch, washer/dryer combo, Webasto heat, freezer/refreezer. 75hp turbo Yanmar, 3-blade Autoprop. Excellent condition. (509) 981-3838 or jlandsm@comcast.net.



**44-FT ANTIGUA, 1985.** Southeast Asia. \$172,000. Fully-equipped, well maintained cruising yacht. Conveniently located in a beautiful cruising ground. Loads of storage and headroom, walk-in engine room, huge center cockpit. Ideal for cruising. See website for details: [www.totalgood.com/australis](http://www.totalgood.com/australis). (904) 297-3229 or larissa@totalgood.com.

## 40 TO 50 FEET

**46-FT KELLY PETERSON, 1982.** Morro Bay. \$174,000. Cruise ready with long list of equipment. 2 staterooms, 2 heads with new electric toilets, reefer and freezer, large center cockpit, etc. Comfortable and great sailing boat that's ready to go anywhere! [www.facebook.com/pages/Kelly-Peterson-46-sailboat/172704439424234](http://www.facebook.com/pages/Kelly-Peterson-46-sailboat/172704439424234). Contact woodeneye53@yahoo.com or (805) 459-1909.



**41-FT CT, 1976.** Vallejo. \$65,000/obo. Veteran cruising yacht. Owned by the same owner since 1976. It has many cruising extras. Sails, anchors, and ground tackle. Set of world charts. 75hp Volvo diesel. (415) 726-3322 or maspragg@aol.com.

**TAKEN OFF MARKET**

42-  
\$11  
A/C  
can  
flat  
separate shower.



**43-FT TASWELL, 1995.** Bainbridge Island, WA. \$299,000. Pristine, center cockpit full enclosure, Leisure Furl main, electric winch, RF genoa, low hours on main and 5kw genset, watermaker, chart plotter, radar, Espar heat, much more. <http://nxtues.wordpress.com>. Contact ntuesday1995@hotmail.com or (206) 295-1024.



**46-FT SLOOP WOOD HULL.** F.S.Ford design, 1961. Marina Mazatlan, Mazatlan, Mexico. \$61,000. Cold molded 3-layer red cedar over classic wooden hull. South Pacific veteran. SS rigging, aluminum mast, boom, spinnaker pole. Contact for photos: [kd6pgz@aol.com](mailto:kd6pgz@aol.com) or (530) 656-2157.



### OFFSHORE PASSAGEMAKING INSTRUCTION IN THE SOUTH PACIFIC

John & Amanda Neal are dedicated to providing hands-on, documented instruction aboard their Hallberg-Rassy 46 *Mahina Tiare III*, drawing on their combined 544,000 miles and 69 years of experience. [www.mahina.com](http://www.mahina.com) • (360) 378-6131

**PROFESSIONAL DELIVERY CAPTAINS**  
San Diego based, USCG Master 100 GT. Sail and power.  
ASA-certified instructional deliveries. Pacific Mexico and Baja Bash specialists.  
[davidbrotherton@yahoo.com](mailto:davidbrotherton@yahoo.com) • [www.boatdeliverycaptain.org](http://www.boatdeliverycaptain.org)  
• (619) 913-7834 •

*Going Somewhere?* **Mexico ≈ Caribbean ≈ South Pacific**  
Stop by our office and take a bundle of *Latitude 38* magazines along with you.  
*We promise you'll be a hero for sharing them with other cruisers!*  
**Latitude 38 • 15 Locust Ave • Mill Valley, CA • (415) 383-8200 • Open M-F 9-5**

**2012 Northern California Sailing Calendar & YRA Master Schedule**  
Pick one up at our office, 15 Locust Ave., Mill Valley, CA. 94941  
Or go online and download the eBook or order a hard copy at:  
[www.latitude38.com](http://www.latitude38.com)





**45-FT GARDEN YAWL.** One-off, double end, 3 years in restoration, 98% completed, cold-molded over original strip planked, new electric motor. \$60K as is, or \$? to finish. Contact (916) 847-9064 or stevebarber046@mac.com.



**41-FT NEWPORT 41S, 1977.** Cabrillo Marina, San Pedro, CA \$28,500. This is an offshore capable cruiser, Bay fun boat, or comfortable liveaboard. More new sails than you can wear out. Spinnakers, reachers, drifters. Perkins 4-108, new fridge, AIS/VHF radio, A/P, davits, etc. New Interior: cushions, headliner, propane system, etc. Contact raytostado@msn.com or (213) 250-2893 or (213) 300-3446.



**46-FT MORGAN 462, 1981.** Vallejo Marina. \$146,000/obo. Bulletproof center-cockpit cruising ketch, keel-stepped masts, integral ballast, skeg-hung rudder, external chainplates, two cabins/heads, many new systems, immaculate. <http://s766.photobucket.com/albums/xx309/tmsser/Morgan%20462%20Cruising%20Sailboat/?albumview=slideshow&tr>. Contact (707) 334-3670 or baryb@aol.com.



**50-FT FD-12, 1981.** Sea of Cortez. Un-sinkable turn-key blue water cruiser, AK/Mex/SoPac vet. Superb galley in pilot-house. Berths for 5-6 w/2 staterooms fwd and master stateroom aft, ensuite heads and great fore/aft privacy. See website for details: [www.svdaydreamer.com](http://www.svdaydreamer.com).

**40-FT ACAPULCO, 1976.** Mazatlan, MX. \$59,000. Designed and set up for cruising, safe with easy motion at sea. Two dinghies, hydraulic and wheel autopilots, Monitor windvane, solar panels, Technautics refrigeration, new radar, new Yanmar 3JH5E engine. <http://TotalYachtSales.com>. (866) 380-8522 or (669) 913-4272 or jaw1962@att.net.



**44-FT TARTAN 4400, 2003.** Channel Island Harbor. \$399,000, or trade? Reduced price! Dark green hull, low hours, bow thruster, electric winches, Vacuflush heads, spinnaker, new batteries, recent bottom paint, numerous other options/upgrades. See test sail at [www.youtube.com](http://www.youtube.com), search Tartan 4400, our actual boat! Contact amgjohn@sbcglobal.net or (530) 318-0730.



**48-FT ISLANDER, 1985.** Sausalito. \$179,000. This is a classic Ted Brewer design built by Islander. Pristine condition, 3 year renovation just completed. Just about everything is new, sails, rigging, plumbing, pumps, etc. Call or email for all the information. (415) 846-6919 or (415) 331-6200 or sailonbaby@gmail.com.



**41-FT CORONADO, 1972.** Loreto, BC \$41,000. Center cockpit ketch. Turn-key condition. Perkins 4107. Watermaker, radar, solar, Hypalon 310 RIB, 15hp outboard, davits. Too much to list. Sails great, shows well, and is roomy. In Puerto Escondido, BC on private mooring (included). Contact (310) 663-7776 or thesolarequity@yahoo.com.



**50-FT FERRO-CEMENT SAILBOAT.** 1980. SRYH. \$75,000. Converted for liveaboard 700+sq ft. 3 bedrooms, bath and 1/2. Hardwood floors throughout, except galley is tiled. 190,000 BTU tankless hot water, washer/dryer, 40,000 BTU central heat and wood burning parlor stove. More photos at <http://picasaweb.google.com/mikemacleancotten/50FootLiveaboard>. Contact (415) 601-9559 or m.cotten@yahoo.com.

## 51 FEET & OVER

**59-FT SAMSON KETCH, 1972.** Newport Beach, CA. Video available via email. Custom built 3 staterooms, two heads, seating for 8, inside steering station. Mahogany interior. 9 knot calculated speed. Never been in water. In drydock in Newport Beach, CA. (714) 963-9282.

**52-FT IRWIN, 1984.** Puerto Vallarta, Mexico. \$245,000. Gorgeous Irwin 52 ketch. Love the boat and would rather have a 50% partner than sell outright. Tons of upgrades. See website for all the info. [www.freya52.com](http://www.freya52.com). (530) 342-1665 or freya52@live.com.



**63-FT STAYSAIL SCHOONER, 1976.** Coronado, CA. \$125,000/Asking. Classic naval architect-designed/professionally built 63-ft LOD Samson "C-Witch" ferro cement staysail schooner. Magnificent interior, teak deck. Great blue water cruiser/charter yacht. Recently hauled, good surveys. Must see to appreciate the extensive quality design detail work. One owner since launched in 1976. Licensed captain/professional yacht builder. Must sell due to age/health. More than \$450,000 in construction costs. Please see URL link for details/pictures. [www.schooner4sale.com](http://www.schooner4sale.com). Email [captjmich@gmail.com](mailto:captjmich@gmail.com).

## CLASSIC BOATS



**40.5-FT NORDEREY, 1952.** Moss Landing Harbor, dock A71. \$20,000/obo. Built in St. Monans, Scotland. All wood. Hull in excellent shape. Needs work. One owner for 35+ years. Perkins 4-108 engine. Full sail inventory plus, Aries self steering. Looking for a good steward. Contact Tim: [norderey1@yahoo.com](mailto:norderey1@yahoo.com) or (209) 570-9951.



**45-FT SPARKMAN & STEPHENS, 1960.** Ballena Isle Marina. \$40,000. S&S design #708. Argentina built of local hardwood, copper riveted. 45' LOA; 31' LWL; 10' 8" beam; 6'4" draft. Recent decks and rigging. Aluminum spars. Tiller steering. A-tohelm. Master Mariners and Jessica Cup competitor. New full boat covers. New spinnaker. New LPU topsides. 35hp BMW diesel; runs, needs work. [picasaweb.google.com/109279823363611668825/Valiant45SparkmanStephensSloop.510](http://picasaweb.google.com/109279823363611668825/Valiant45SparkmanStephensSloop.510) 846-4178 or [jmcnish@earthlink.net](mailto:jmcnish@earthlink.net).

## MULTIHULLS



**38-FT SPIRITED 380, 2010.** Ventura. \$425,000. 1.5 years new. Custom built Jim Betts. High quality fit/finish, Volvo saildrives, sleeps 6, 2 heads, watermaker, 2 steering stations, GM Sails Australia, carbon daggerboards w/spare, carbon retractable sprit. [www.bayadere.info](http://www.bayadere.info). Contact [dabney@cox.net](mailto:dabney@cox.net) or (805) 689-7306.



### NEW... Kiwi Grip Non-Skid • Non-Skid Decks by Gordie GORDON NASH BOAT BUILDERS

Local... as in Sausalito. I have samples. Custom colors available.

[gcnjr@earthlink.net](mailto:gcnjr@earthlink.net) • (415) 332-7269

### THIS COULD BE YOU...

Let the Classy Classified business ads work for you.

Submit online at:

[www.latitude38.com](http://www.latitude38.com)

### MULTIHULL YACHT DESIGNER • MARINE SURVEYOR

John R. Marples, CMS • Certified, National Association of Marine Surveyors  
Multihull Design Specialist • Pleasure and Commercial  
Design office for Jim Brown Searunner, Seaclipper & Constant Camber Multihulls  
[www.searunner.com](http://www.searunner.com) • (707) 343-1378 • [marplesmarine@comcast.net](mailto:marplesmarine@comcast.net)

### YOGA FOR SAILORS ON THE SAN RAFAEL & ALAMEDA WATERFRONT

Small group classes in San Rafael Tues./Thurs. evenings, Sat. mornings at Evie Too Sailing in Alameda. More info: (415) 785-4530, (510) 333-8846, [www.bowyooga.com](http://www.bowyooga.com), [www.evietoo.com](mailto:www.evietoo.com), [yogaforu2009@gmail.com](mailto:yogaforu2009@gmail.com).

Bow Yoga



**34-FT GEMINI 105MC, 2005.** Redwood City, California. \$149,500. Great family or race boat. Perfect for San Francisco Bay, coast, Mexico, and beyond. Fast; easy to sail without heeling. Spacious deck and interior. Elegant and comfortable. See website details. <http://loonasea.gibbons.web.stanford.edu>. Contact (650) 380-3343 or [brian.j.gibbons@gmail.com](mailto:brian.j.gibbons@gmail.com).



**30-FT AUGNAUGHT, 1995.** Moss Landing, CA. A practical, trailerable trimaran you can take home with you. Waiting for you in Monterey Bay, California. Go to [www.yachtsoffered.com](http://www.yachtsoffered.com) and under "search for a boat section" type in Listing #1291771. No reasonable offer refused. \$500 referral fee for when Zoom sells. Contact [hawknest1@prodigy.net](mailto:hawknest1@prodigy.net) or (831) 247-7939.



**33-FT SEAWIND 1000, 2002.** Paradise Village, MX. \$175,000. Seawind 1000 33' catamaran in Puerto Vallarta - enjoy the rest of the season! Substantial refit this year. New Code Zero on Farcnor furler, Furling jib, main on Harken bat-cars, lazyjacks (easy to handle with 1-2 people). Asymmetrical in sock. New Garmin 740s chartplotter w/chip (NA/Mex), new Garmin HD Radar, 80% LED lighting, New Rocna anchor, No leaks, bone dry. New 130w solar panels (x2), 4 new AGM batteries (360 amp hours), new MPPT BlueSky controller. Insulated canvas enclosure. Xantrex 2000 inverter, AB aluminum RIB, Yamaha 8hp. Excellent and seaworthy cat! <http://picasaweb.google.com/100296617853657885709/Seawind1000?authkey=Gv1sRgCM6Hr dnvjZLQjwE&feat=email>. Contact (415) 683-1990 or [memymo@gmail.com](mailto:memymo@gmail.com).

## POWER & HOUSEBOATS

**17-FT BOSTON WHALER MONTAUK.** 1975. **SOLD**



**53-FT KRISTEN STEEL TRAWLER.** 2005. La Paz, Mexico. \$850,000. *Mystic* is a rugged offshore raised pilothouse trawler built to the highest specifications by Kristen Yachts in Sidney, BC. She can easily be handled by two people and features a steel hull with a luxurious cherry interior. She was cruised extensively in British Columbia for 5 years, including two circumnavigations of Vancouver Island, before making the passage from Canada to Mexico in 2010. *Mystic* has the range to make ocean crossings and is ready take her new owners anywhere in the world. 300hp John Deere, 16kW Northern Lights, get-home, stabilizers, hydraulic bow and stern thrusters. Furuno and Simrad instruments. 6-man Viking liferaft, 2 dinghies, 2 outboards. See website for full details: [www.mystic53.com](http://www.mystic53.com). Email [david@fullagar.net](mailto:david@fullagar.net).



**47-FT C&L SEA RANGER.** Pilothouse trawler, 1980. San Diego, Harbor Island. \$84,000. Fiberglass twin Ford Lehman's just refit, new appliances, paint, fresh survey and bottom with thru-hulls. All specs and pictures view site. NICE boat! [www.searanger47.com](http://www.searanger47.com). (480) 948-7053 or [kstrecker50@gmail.com](mailto:kstrecker50@gmail.com).



**37-FT HERSHINE, 1979.** Emeryville. \$74,500. Your front-row seat to America's Cup! Cruise the Bay, dawdle on the Delta, cruise to Mexico, or liveaboard this roomy, tri-cabin classic trawler with gobs of interior upgrades and exterior canvas plus nifty electronics such as Garmin 4208 chart plotter, RM AP w/remotes. Easy-on-the-wallet single 120 hp Lehman diesel. A stern thruster makes even cross-wind docking easy. Transferable slip with first month free rent. Email for full specs and photos: [jhbueto@surewest.net](mailto:jhbueto@surewest.net).



**49-FT CUSTOM TRAWLER YACHT.** Liveaboard cruiser, 2005. La Conner, Washington. \$275,000. Urgently need to sell ASAP! Reduced from \$399,000! Spacious, beautiful, loaded with systems, impeccably maintained, comfortable, classy. [www.shipshapessystems.com/MaverickForSale.html](http://www.shipshapessystems.com/MaverickForSale.html). Contact (360) 298-1793 or [maverick08@earthlink.net](mailto:maverick08@earthlink.net).

## PARTNERSHIPS

**C&C LANCER 30.** Non-equity partnership. Sausalito. Excellent condition. Wheel steering, self-furling jib, dodger, 15hp inboard. Autopilot, fathometer, GPS 9" display, wind indicator, VHF. Exquisite interior: galley, stove/oven, head, AM/FM/CD stereo. \$150/month, \$600 security deposit. Contact (415) 459-7417 or [ed\\_currant2002@yahoo.com](mailto:ed_currant2002@yahoo.com).

**SAGA 409 PARTNERSHIP SFYC.** Equity ownership in new Saga 409. Semi-custom Tony Castro design built by Westerly Marine. Vacuflush, flat screen TV, microwave, wine cellar. Electric halyard/mainsheet winch. Fast, easy to sail. Call or email for pics and specs. (415) 298-2080 or [george@kiwi-properties.com](mailto:george@kiwi-properties.com).

## SOUTH OF THE BORDER



**PLAN YOUR MEXICO GETAWAY NOW.** at the brand-new, gorgeous Cielo Y Mar condos. Located in Punta Mita, 35 minutes from Puerto Vallarta, available to rent from private owner. On the beach, 10 feet from the water, they offer spectacular views of ocean and mountains, the biggest infinity pool in the area, an endless beach, great surf breaks, great fishing, tremendous views of whales, bird life and the islands. While uncrowded and tranquil, just a five-minute walk to several waterfront restaurants. Choose from a spacious, beautifully furnished one or three-bedroom unit, or an amazing two-story penthouse with lovely shade trellis on the top floor. See details at website. [www.puntamitabeachfrontcondos.com](http://www.puntamitabeachfrontcondos.com). To reserve, call Dona de Mallorca (415) 599-5012.

**COME JOIN US FOR A WEEK.** Take a vacation! Learn or share your sailing skills with a USCG Captain. We have no itinerary. Email us to find out where we will be on your desired dates. Form a group up to 6 of your friends and have the whole boat - a 52' ketch with the finest amenities. Shared expenses of only \$700/person/week includes, food, fuel, slip fees, scuba gear and tank fills. Great food, good friends, and adventure. Email [frey52@live.com](mailto:frey52@live.com).

## TRADE



**READY FOR A CHANGE?** I need to go sailing! Donner Lake, California. \$199,000. Breathtaking view lot just minutes to world class skiing, hiking, cycling, and climbing. Looking for offshore world capable catamaran OR sailing yacht. For a detailed description and video visit: [www.KensPropertiesOnline.com](http://www.KensPropertiesOnline.com). (530) 412-1068 or [kfairchild@jps.net](mailto:kfairchild@jps.net).



**READY FOR A CHANGE? I NEED TO GO SAILING!** 71 riverfront acres for sale or trade. Located in Northern California's Sierra Nevada wine country. Looking for offshore world capable catamaran or sailing yacht. Full info and video at: [www.kenspropertiesonline.com](http://www.kenspropertiesonline.com). (530) 412-1068 or [kfairchild@jps.net](mailto:kfairchild@jps.net).

## WANTED

**SANTANA 2023C.** In good condition, with trailer. Please contact: (360) 379-4186 or [patriciaandjaap@olympus.net](mailto:patriciaandjaap@olympus.net).

**45'-50' AMERICAN MADE SAILBOAT.** Seeking a multi-cabin 45'-50' American made sailboat to replace our Islander 44 crewed charter boat out of Molokai. Have your boat maintained, operated, and secure in Hawaii with time for personal use. Info at website <http://sailmaui.com> or call Mike for details: (808) 870-1741.



## MARINE SURVEYOR

Sharpe Surveying & Consulting. SAMS Accredited Marine Surveyor. Serving the San Francisco Bay and Delta.

[RSharpe@SharpeSurveying.com](mailto:RSharpe@SharpeSurveying.com) • (510) 337-0706

*Latitude 38 eBooks*

FREE ★ AVAILABLE WORLDWIDE ★

[www.latitude38.com/ebooks.html](http://www.latitude38.com/ebooks.html)

**CPT**  
AUTOPILOT

**Get the Reliable, Powerful Wheel Pilot**

Quiet & Dependable • Affordable • Built for Immersion  
Easy Owner Installation • Low Power Consumption

831-687-0541

[www.cptautopilot.com](http://www.cptautopilot.com)



**DOGGIEVENTURE** – A doggie daycare on the go!

Morning, mid-day or afternoon sessions available in San Francisco

**Training • Boarding**

[www.doggieventure.com](http://www.doggieventure.com) • (415) 314-7541

## GEAR

**ONLINE MARINE GARAGE SALE.** Private party. Used, and some new, marine items for sale. 2004 Zodiac Mark I Classic, Switlik MD-3 with cradle, Centek Gen-Sep, Wallas stove and oven, Garmin GPSMap76, bronze pipe and hose fittings. Lots more. [www.eolais.com](http://www.eolais.com). Email [sales@eolais.com](mailto:sales@eolais.com).

**74-FT MAST.** Designed for catamaran. Best offer. (415) 269-5165.

**THREE STRAND LINE.** Close out sale. Spools and hanks of three strand line. Excellent for sheets, halyards and dock lines for your classic yacht. Hempex rope is from spun Polypropylene. Very hard to tell apart from real hemp. An economical alternative for running rigging on your classic yacht. Hempex is gentle on the hands, is easy to splice and has an authentic natural look. Traditional line of the 21st century for your classic yacht. Contact Jim Linderman: (415) 827-6694, (415) 259-7874 or [jlinman@hotmail.com](mailto:jlinman@hotmail.com).

**SWAN 59' SAILS.** \$7,000/obo. North Sails, older but great condition, can be cut down. I-24.25M, J-7.06M, P21.80, E6.30. Racing (main): #1/#3 Kevlar. Spinnakers: 1.5/.75/.5 oz, Guys/Sheets. Cruising: #1/#3 Dacron, Storm. Take all or singles. Contact [dlohrey796@aol.com](mailto:dlohrey796@aol.com) or (415) 209-8395.

## MISCELLANEOUS



**PAY TO PLAY SAILING SAUSALITO.** \$100. Learn to sail or crew on a race boat. Beneteau 45ft luxury race boat that is ready to race around buoys, or in the ocean. We will be doing all the major regattas and series this year. \$100 per race. [www.bayandocceanracing.com](http://www.bayandocceanracing.com). Contact Steve. (415) 847-0179 or (415) 457-4417 or [Deanstevenshocking@msn.com](mailto:Deanstevenshocking@msn.com).



**ROSSIGNOL 195CM SKIS.** Tiburon or Mill Valley. \$20. Rossignol Progress Skis. 195 cm long. Very good condition. Contact [chris@latitude38.com](mailto:chris@latitude38.com), (415) 383-8200 ext:103 or (415) 250-9334.

## TRAILERS

**2007 ROAD KING \$5,200/OBO.** Heavy duty sailboat trailer for sale. Triple axle, for boats 20-30 feet. GHW (of boat) 14,000 lbs., up to 5 foot draught. Eight jack stands and surge brakes. New condition. (714) 305-1959 or (562) 899-0774.

## CLUBS & MEMBERSHIPS

**SINGLE SKIPPERS AND CREW** of all abilities are invited to join the Single Sailors Association. Membership includes daysailing, social events. Meetings held 2nd Thursday, Ballena Bay Yacht Club. Social 6:30pm; Meeting 7:30pm. Guests welcome. [www.singlesailors.org](http://www.singlesailors.org). (510) 239-SAIL or (510) 239-7245.

**CLUB NAUTIQUE.** Couples Passagemaker Membership. \$5,450 (regular 6,800). Club Nautique is the best sailing club in the Bay Area with bases in Sausalito and Alameda. They have more than 35 sailboats (up to 50 feet in length) and several power boats available for charter. The CN Passagemaker couples membership includes all US Sailing lessons up to Open Water passagemaking for 2 people (>\$13,000 if purchased separately). Sail on the Bay, out the Gate or bare-boat in the Caribbean. We have just bought a 47-ft catamaran and no longer need our membership. From CN = \$6,790, from us as transfer = \$5,450! See at [www.clubnautique.net/sailing/membership/types.html](http://www.clubnautique.net/sailing/membership/types.html). Contact Tony. (415) 235-3978 or [tonyday@earthlink.net](mailto:tonyday@earthlink.net).

## BERTHS & SLIPS

**PIER 39 SLIP.** SF. \$45,000. 45-ft, close in east side E dock. Includes reduced covered parking rates, showers, and laundry facilities. 22 years left on original sublease. Great views of Coit Tower and Bay. Contact Curtis. (916) 969-8077 or [curtis@surewest.net](mailto:curtis@surewest.net).

**SLIPS AVAILABLE.** Aeolian Yacht Club, 20'40' @ \$4.90 a foot. MUST be a club member. Join Aeolian now and bring in your boat. Initiation fee is only \$200. Call: (510) 523-2586 or (510) 769-9205.

**PERFECT LOCATION PIER 39.** 50' Dock F, Slip 22. San Francisco. \$49,500. Slip strategically located for America's Cup. Slips rarely come on market. Selling interest in sublease expiring in 2034. See website for photos: [www.pier39marina.com](http://www.pier39marina.com). Contact (310) 804-9136 or (310) 230-5203 or [cfpmap@gmail.com](mailto:cfpmap@gmail.com).

**50-FT PRIME SLIP PIER 39, SF.** \$50,000. F-Dock, Slip 11, east side. Protected from wind. Close to gangway, showers and marina office. Covered parking across street with special rates for owners. Contact [scorch@tempest-edge.com](mailto:scorch@tempest-edge.com) or (559) 355-6572.

**MAKE \$\$ WITH YOUR BOAT** at South Beach Harbor! Prime berths/great income. Must be no older than 10 years. Call or email Drew at Spinnaker Sailing, [spinnaker.sailing@yahoo.com](mailto:spinnaker.sailing@yahoo.com) or (415) 543-7333.

**PIER 39 36' SLIP RENTAL.** San Francisco. \$35. This is a 36'x13.5' slip located at Pier 39 Harbor. \$35/night or \$700/month. Email interested dates and I will reply ASAP. I will coordinate stay, and access with the harbor master. (916) 484-1031 ext: 3120 or [sndmnsix@hotmail.com](mailto:sndmnsix@hotmail.com).

## CREW

**AHOY OCEAN ADVENTURERS.** Seeking one to two crew members to participate in 'Pacific Puddle Jump' leaving Oahu May 18, to sail French Polynesia for three months, stopping in Tahiti for the Heiva Festival celebration. Financial participation expected for the privilege of an adventure of a lifetime on a first class 53' Amel Super Maramu sailing yacht. Please respond to Capt. Billy Moore at (714) 827-0229 or email [carolannreese@gmail.com](mailto:carolannreese@gmail.com) with questions regarding participation.

**CAPTAINS, FIRST OFFICERS & CREW.** Rendezvous Charters is hiring ships crew and licensed masters to sail our 80 passenger schooner, *Bay Lady*. Part time or full time. Excellent wages/benefits. Mid-week and weekend work available, flexible schedule! Want to enjoy your job? Building your sea time? Join this rapidly growing company! GREAT PEOPLE, fun company. Email resume, or call Abby. [staff@spinnaker-sailing.com](mailto:staff@spinnaker-sailing.com) or (415) 543-7333.

## JOBS WANTED

**PROFESSIONAL COUPLE.** Yacht skipper and registered nurse available. Redwood City, California, USA. Sailboats, primarily SF Bay and coastal California, but also; Fiji, Australia, Mediterranean, Canaries. Experienced captain of large vessels from 48 to 65 feet. Perfect safety record. Navigation, rigging, engines, electronics, cooking, cleaning, new equipment, outboards, sailing instruction, computer/internet, childcare, healthcare, pet care, maintenance, repair and troubleshooting skills. Spanish/English speaking. Will consider relocating for the right boat and well paid jobs. Excellent references. Contact (435) 216-6655 or (650) 257-7300 or [yarboat@msn.com](mailto:yarboat@msn.com).



## JOB OPPORTUNITIES

**BOAT CAPTAIN.** San Francisco Bay and Delta. Local Vessel Assist has an opening for part/full time captain to work on the San Francisco Bay and Delta. Must be USCG licensed with towing endorsement. If interested, contact Philip Delano: (925) 382-4422 or [Philipdelano@gmail.com](mailto:Philipdelano@gmail.com).

**6-PAK CAPTAINS & Sailing instructors.** Spinnaker Sailing in SF, is hiring F/T or P/T aboard our fleet of 22- to 90-ft sailing yachts. Mid-week and weekend work available, flexible schedule. Email resume to [staff@spinnaker-sailing.com](mailto:staff@spinnaker-sailing.com) or call Abby: (415) 543-7333.

**MARINE TECHNICIAN.** Hirschfeld Yacht is a Bay Area leader in the sales, repair, service, installation, and customization of marine diesel engines and generators. We are looking for marine technicians to join our team. Minimum qualifications: 2+ years direct mechanical/electrical experience. Experience with gas and diesel engines ranging from 10-300hp, inboards and outboards. Experience with manufacturers such as Mercruiser, Mercury, Honda, Yamaha, Beta Marine, Yanmar, Perkins, Volvo, or Universal. Expertise in electrical systems with a solid understanding of electrical fundamentals. Clean background check. Must have a California driver's license and car/truck. Must have own tools and mobile tool kit/bag. Preferred qualifications: ABYC Certifications, manufacturer specific certifications, gas/diesel technology certifications, electrical certifications. For more information and to apply, email: [hycbetawest@gmail.com](mailto:hycbetawest@gmail.com).



## MARINE ENGINE CO.

Complete Engine Services • Gas & Diesel  
30 Years Experience • Reasonable Rates  
Tune-Ups • Oil Changes • Engine Rebuilding, etc.  
(415) 332-0455

## Afterguard Sailing Academy The Affordable Way to ASA

ASA Basics to Ocean • Crew Intro to Cruising Prep  
(510) 535-1954 • [www.afterguard.net](http://www.afterguard.net)



## South Pacific Itinerary: Hawaii, Tahiti, Cooks, Fiji

[www.cruisingexpeditions.com](http://www.cruisingexpeditions.com)

Adventure Sailing to Destinations beyond Imagination for Experienced to Novice Sailors that have enthusiasm for adventure; Sail, Scuba, Surf. 805-709-4567  
**UNPLUG - EXPAND YOUR WORLD • Instruction / Itinerary / Package Details**

*Need Crew? Latitude 38 Crew List A Boat to Crew on?*

☆ Visit our website and sign up as Skipper or Crew ☆ It's Free

Find out about our next Crew Party: Wed., March 7, at Golden Gate Yacht Club  
[www.latitude38.com/crewlist/Crew.html](http://www.latitude38.com/crewlist/Crew.html) or call (415) 383-8200



## BUSINESS FOR SALE



### DIESEL FUEL FILTERING



*Purify Diesel Fuel & Flush Tanks*

Process scrubs, polishes, removes algae, dirt, sludge, rust, water, and foreign particles from diesel fuel. Includes internal tank washdown. Save your injectors, costly engine repair and down time.

*Since 1989. Fully insured. Your berth or boat yard.*

**(510) 521-6797 Fax: (510) 521-3309**

**www.dieselfuelfilterings.com**



*A Sailor's  
Consignment  
Chandlery*

**NEW & USED BOAT GEAR**

Open Tues.-Sat. 10 to 5 p.m.

**510-769-4858**

Located at Grand Marina

**www.bluepelicanmarine.com**

### Marine Diesel Specialists AT YOUR SLIP!



30 years experience • Universal/Westerbeke dealers  
Repairs/Tune-ups all models • Engine Surveys, Instruction

**BAY MARINE DIESEL**

**510-435-8870**

**baymarinediesel@comcast.net**



### MARINE BATTERIES



*Available at the following local marine  
chandlerys and service distributors:*



#### ALAMEDA

- Alameda Prop & Machine
- Fortman Marina Store
- The Boatyard at Grand Marina
- Star Marine
- Svendsen's Chandlery

#### BENICIA

- Cruising Seas Services

#### MARTINEZ

- Diablo Marine

#### OAKLAND

- Golden State Diesel
- Outboard Motor Shop

#### OAKLEY

- Big Break Marina

#### RICHMOND

- Swedish Marine
- Bay Marine

#### SAUSALITO

- Sausalito Marine

**AMERICAN BATTERY • Hayward, CA • (510) 259-1150**

## ADVERTISERS' INDEX

AB Marine..... 34	Boat Yard at Grand Marina, The..... 23	Doyle Sails ..... 89	Helmut's Marine Service.... 57	Marchal Sailmakers..... 119
Almar Marinas..... 43	BottomSiders..... 125	Dr. LED ..... 42	Heritage Marine Insurance 97	Marina Bay Yacht Harbor ..... 29
Alpenglow Marine Lights..... 125	Brisbane Marina ..... 95	Drake Marine ..... 44	Heritage Yacht Sales..... 153	Marina de La Paz..... 141
American Battery ..... 149	CYOA Yacht Charters..... 123	Easom Rigging..... 82	Hirschfeld Yachts ..... 46	Marina El Cid ..... 136
Antares Yachts ..... 55	California Yacht Sales..... 152	Emery Cove Yacht Harbor ..... 53	Hogin Sails ..... 10	Marina Mazatlan ..... 39
BVI Yacht Charters..... 124	Casey's Slip/Richard Wren, author ..... 58	Emeryville Marina ..... 96	Hood Sails..... 21	Marina Puesta del Sol..... 140
Bacon Sails & Marine Supplies..... 59	City Yachts..... 11	Equipment Parts Sales.... 139	Hotwire Enterprises..... 119	Marina Village/Boat Fest.. 31
Ballenger Spars..... 83	Club Nautique ..... 38	Essex Credit Corp..... 14	Hydrovane..... 140	Marine Lube ..... 124
Barz Optics ..... 97	Conch Charters..... 125	Farallone Yacht Sales..... 9	Interlux Yacht Finishes..... 37	Marine Outboard Company..... 16
Bay Marine Boatworks..... 35	Cover Craft..... 42	Flying Cloud Yachts ..... 151	Iverson's Design ..... 48	Marine Surveyors..... 111
Bay Marine Diesel ..... 149	Coyote Point Marina..... 77	Forespar..... 111	JK3 Nautical Enterprises ... 27	Mariner's General Insurance ..... 101
Berkeley Marine Center ..... 25	Cruise RO Water..... 91	Fortman Marina..... 91	Kissinger Canvas..... 94	Maritime Institute..... 97
Beta Marine Engines..... 46	Cruising Yachts ..... 7	GCM Rigging and Composites ..... 116	KKMI - Brokerage..... 153	Marotta Yachts..... 154
Blue Pelican ..... 149	Dart, The ..... 111	Gentry's Kona Marina ... 119	KKMI - Boatyard ..... 156	Mast Mate ..... 139
Blue Water Yacht Insurance ..... 6	Davis Instruments..... 106	Gianola Canvas Products..... 106	Kona Kai Marina ..... 88	Mathiesen Marine ..... 110
Boat Electric..... 40	Defender Industries..... 46	Grand Marina ..... 2	Lee Sails ..... 125	McDermott Costa Insurance ..... 94
Boat U.S. Insurance..... 107	DeWitt Studio ..... 119	Hansen Rigging ..... 105	Leopard Catamarans ..... 49	
	Diesel Fuel Filtering ..... 149	Harken ..... 26	List Marine Enterprises ..... 56	
			Loch Lomond Marina..... 104	
			Makela Boatworks..... 141	

CONTINUED ➤

# FILL UP YOUR COCKPIT WITH RACE CREW

at

## Latitude 38'<sup>1</sup>/<sub>2</sub> Spring Crew List Party

Wednesday, March 7  
Golden Gate Yacht Club

Details and free online crew list  
at

[www.latitude38.com](http://www.latitude38.com)



## ADVERTISERS' INDEX – cont'd

McGinnis Insurance..... 50	Oxbow Canvas and Upholstery ..... 54	Ryan's marine ..... 124	Southbound Solar ..... 136	weatherguy.com..... 141
Minney's Yacht Surplus ..... 138	Oyster Cove Marina..... 59	Sail California..... 12, 13	Spectra Watermakers ..... 110	Wedlock, Ramsay & Whiting Marine Surveyors ..... 138
Modern Sailing School & Club ..... 19	Pacific Crest Canvas ..... 30	Sail Warehouse, The ..... 141	Start Line Strategies..... 119	West Coast Multihulls ..... 151
Multihull Company, The .. 152	Pacific Rigging..... 111	Sail-A-Small-Boat Day/ Richmond YC ..... 15	Stem to Stern ..... 48	West Marine..... 18, 20, 22
Napa Valley Marina..... 52	Paradise Village..... 33	Sailing Elsewhere/ Matt Johnston, author .. 139	Sterling Associates ..... 124	West Marine - Rigging..... 36
New Era Yachts..... 151	Park Presidio Marine ..... 90	Sailing The Bay ..... 47	Strictly Sail Pacific ..... 45	Westwind Precision Details ..... 51
New Zealand Non-Skid of CA ..... 56	Passage Yachts..... 5	Sailrite Kits ..... 8	Svensden's Boat Works ..... 17	Whale Point Marine Supply ..... 24
Norpac Yachts ..... 155	Pineapple Sails ..... 3	Sal's Inflatable Services..... 87	Swedish Marine ..... 54	White, Chris Designs..... 124
North Beach Marine Canvas ..... 51	Punta Mita Beachfront Condos..... 141	San Francisco Boat Works..... 86	TMM Yacht Charters ..... 123	Wiest, Michael, Yacht Sales ..... 152
North Direct Sails..... 58	Quickline..... 53	San Juan Sailing ..... 125	Trident Funding ..... 4	Yacht Racing Assoc... 117, 118
North Sails ..... 41	Raiatea Carenage Services ..... 137	Scanmar International ..... 59	Twin Rivers Marine Insurance ..... 90	Yachfinders/Windseakers 15
North U..... 83	Ramp, The ..... 138	Schoonmaker Point Marina ..... 28	Uli Boards ..... 138	
Oakland Yacht Club ..... 40	Reliable Marine Electronics..... 57	Sea Frost ..... 53	Ullman Sails..... 110	
Opequimar Marine Center ..... 88	Richardson Bay Marina ..... 57	Seashine..... 55	VacuWash ..... 52	
Outboard Motor Shop ..... 50	Riverside Marine Transport ..... 124	Seatech ..... 125	Vallejo Marina ..... 91	
Owl Harbor Marina ..... 55		South Beach Harbor ..... 32	Variprop USA ..... 44	
		South Beach Riggers..... 51	Ventura Harbor Boatyard..... 83	
			Washkowitz, Jared A., Maritime Law Offices ... 124	







# Flying Cloud Yachts



**Johns  
Christian**

6400 Marina Drive  
Long Beach, CA 90803

Sail • BROKERS • Power

www.yachtworld.com/fcyachts  
flyingcloud@verizon.net

Phone (562) 594-9716  
Fax (562) 594-0710



53' LAPWORTH KETCH, '60 \$120,000



43' TASWELL CUTTER, '89 \$209,000



46' SWAN, '84 \$229,000



42' CATALINA, '89 \$99,000



36' CATALINA, '86 \$39,500



34' CATALINA MkII, '01 \$88,500 & '87 \$39,500



28' CAL sloop, '86 \$24,500



34' PACIFIC SEACRAFT, '88 \$99,500



36' ISLANDER SLOOP, '78 \$41,500



44' HARDIN, new LP paint \$99,000



36' ISLANDER SLOOP, '73 \$15,000



37' CF CHOATE, '78 \$39,900

APPROX. 100 LISTINGS ON OUR WEB SITE: [www.yachtworld.com/fcyachts](http://www.yachtworld.com/fcyachts)



## FALL IN LOVE WITH A NEW SAILBOAT!



### 50' VALIANT, 2001

Ocean proven, ocean equipped world cruiser with impeccable credentials. An extraordinary yacht ready for your inspection. \$535,000

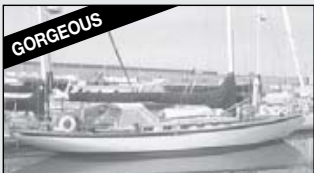

### 57' ALDEN YAWL, '31

Own a Master Mariners treasure. \$295,000



### 32' FUJI, 1976

Must see, meticulously maintained and upgraded. Great value at \$39,500

- 55' HALLMAN SLOOP, '82..... \$165,000
- 51' FORMOSA, '79 Already there! Ready to cruise the Caribbean..... \$150,000
- 50' GULFSTAR, '78 Spacious cruiser..... A great value at \$89,000
- 36' ISLANDER, '76 Great value for West Coast 'Plastic Classic'. 2 from \$30,000
- 32' FUJI, '76 Ready to sail to Fiji right now..... \$45,500



POWER & SAIL

2021 Alaska Packer Pl., Grand Marina, Alameda, CA 94501  
sales@newerayachts.com • daboatman@sbcglobal.net  
(510) 523-5988 • [www.newerayachts.com](http://www.newerayachts.com)

## WEST COAST MULTIHULLS

### Late Model Multihulls!



50' PROUT INTERNATIONAL 50-SW, 2011  
The new generation commissioned 4/11. \$995,000



47' CATANA, 2001  
Meticulously maintained, 2011 refit. \$675,000



44' LAGOON 440, 2004  
Only Lagoon 440 for sale on West Coast! \$549,000



34' GEMINI 105 Mc, 2010  
\$159,000



24'3" CORSAIR SPRINT 750, 2008  
2007 Sportboat of the Year. \$39,000



24'2" CORSAIR F-24 MKII, 2001  
Fresh water boat. Major price reduction. \$35,900

WCM ~ Your source for "Everything Multihull"

Sales/Brokerage: [www.westcoastmultihulls.com](http://www.westcoastmultihulls.com)  
Charters/Sailing School: [www.charter-catamaran.com](http://www.charter-catamaran.com)  
San Diego, CA • (619) 571-3513



# THE MULTIHULL COMPANY

THE WORLD'S LEADER IN MULTIHULL SALES AND SERVICE

[www.multihullcompany.com](http://www.multihullcompany.com)

Let the world's largest international catamaran and trimaran brokerage, The Multihull Company, assist you with the purchase or sale of a multihull anywhere in the world.

The Multihull Company offers several distinct differences, from its pioneering buyer/broker program developed by founder Phillip Berman, himself a World Champion catamaran racer and author, to its international print advertisements that reach just the right buyers and sellers of catamarans, to its monthly newsletters that actually help readers understand the market, the latest trends in sailing, and even tackle the recent controversies about electric engines, helm station placement, daggerboards versus keels, etc., to our powerful online presence and social media know-how and U.S. and European boat show participation.

Visit us at [www.multihullcompany.com](http://www.multihullcompany.com) and see why The Multihull Company is truly the choice for sailors around the world. We offer even the casual browser the means to understand the market with expert videos, articles and an extensive selection of catamarans and trimarans listed for sale.

## FEATURED WEST COAST LISTINGS



**50' CATANA, 2008**  
Seattle, WA  
**£700,000**



**46' DOLPHIN, 2006**  
Half Moon Bay, CA  
**\$529,000**



**50' CONTOUR, 2004**  
Hawaii  
**\$335,000**



**48' LOOPING**  
Sea of Cortez, Mexico  
**\$450,000**



**53' CATANA, 1994**  
Newport Beach, CA  
**\$449,000**



**58' PROFILE, 1988**  
British Columbia  
**\$525,000**

SAN FRANCISCO SEATTLE FT. LAUDERDALE CHARLESTON FRANCE TURKEY TRINIDAD TORTOLA ST. MARTIN

Office Phone: 215-508-2704 West Coast Office: 206-297-1151 email: [info@multihullcompany.com](mailto:info@multihullcompany.com)

## Michael Wiest Yacht Sales

QUALITY PRE-OWNED SAILBOATS



**44' ALDEN Mk1 CUTTER, 1990 • \$295,000**  
Wonderful cruising yacht. Owners ready to move.



**44' NORDIC, 1980 • \$179,000**  
Completely redone. Ready to go cruising!



**44' TARTAN, 1975 • \$49,000**  
Sparkman & Stephens design, new dodger.



**41' BENETEAU, 1999 • \$109,000**  
Three staterooms, watermaker, solar.



**38' HANS CHRISTIAN, 1979 • \$97,500**  
New Pathfinder diesel. Tough cruising yacht.



**37' HUNTER LEGEND, 1989 • \$44,000**  
Aft cabin queen berth. Great layout.

[www.mwiest.com](http://www.mwiest.com)

(510) 601-5010 • Emeryville, CA

**30 Years in the Same Location  
30 Years of Great Service!**

**75 Spectacular Listings  
5 Knowledgeable Brokers  
6 Catalinas Starting at Just \$18,500  
*There's never been a better time  
to buy a sailboat!***

Discover all the reasons why at  
**[www.californiayachtsales.com](http://www.californiayachtsales.com)**

### TWO FEATURED LISTINGS



**46' BENETEAU 463, 1996**  
This magnificent boat has three separate cabins and beautiful main salon. \$139,900



**36' CATALINA MkII, 2003**  
Extremely low hours and loaded with most every option. \$118,500

**CALIFORNIA**  
YACHT SALES

(619) 295-9669 • [www.californiayachtsales.com](http://www.californiayachtsales.com)





# Maritime Yacht Brokerage

**LIST WITH US!**

(510) 236-6633 • fax: (510) 231-2355 • yachtsales@kkmi.com • www.kkmi.com

530 W. Cutting Blvd., Pt. Richmond, CA 94804



**HYLAS 46** (2002)

Powerful, go-fast cruising yacht for sailors with ambitious plans for comfortable offshore sailing. Set up for short-handed sailing, fully equipped with essentially every option. Meticulously maintained. **\$398,000**



**BALTIC 42 DP** (1984)

Since 1973, Baltic Yachts of Finland have been building comfortable, safe, long distance cruisers with very good sailing and performance characteristics. Doug Peterson design, superbly maintained, hull #29. Asking **\$149,000**



**FRERS 50' CUTTER** (1947) German Frers, Sr., founder of the Frers yacht design dynasty, designed and built this classic wooden cutter for his own personal use. Without regard to cost, she's been restored and refit to better than new condition and shows true to her sailing heritage. Asking **\$295,000**



**HINKLEY BERMUDA 40 MkII Yawl CB** (1968)

Bill Tripp design is highly regarded for classic beauty, superb workmanship and quality details. New sails, dodger, intelligently updated. Excellent condition. Asking **\$139,000**



**HYLAS 49** (2003)

S&S-designed world cruiser, thoughtfully set up for offshore, shorthanded sailing, safety, comfort and low maintenance. Lightly used. **\$475,000**



**SWAN 391** (1984) A beautiful flag blue Ron Holland design which is very well equipped and has had teak decks, engine and standing rigging replaced, and new sails that have never been used. Many extras. Asking **\$129,000**

## HERITAGE Yacht Sales

*Live your Dreams*



DEALERS  
FOR CATALINA  
SAILBOATS AND  
HANS CHRISTIAN  
SAILBOATS

Long Beach-Naples  
Newport Beach  
San Diego  
Wilmington

866-569-2248  
877-389-2248  
760-402-3868  
877-599-2248  
Cell 310-995-9989

[www.heritageyachts.com](http://www.heritageyachts.com)



NEWPORT

43' Hans Christian, '12 \$595,000



NEWPORT

65' MacGregor PH, '90 \$199,000



NEWPORT

54' Jeanneau DS, '06 \$499,000



LONG BEACH

44' Hunter 456, '05 \$225,000



LA HARBOR

44' Lafitte, '86 \$149,900



LA HARBOR

42' Beneteau, '06 \$229,000



LONG BEACH

42' Catalina, '91 \$99,000



NEWPORT

40' Panda Cutter, '82 \$147,500



LONG BEACH

40' Valiant, '75 \$119,500



NEWPORT

39' Jeanneau 39i, '08 \$205,000



LONG BEACH

38' Elan 384, '07 \$184,500



NEWPORT

38' Catalina 385, '12



# Marotta Yachts of Sausalito

Brokers of Fine Sail and Motor Yachts

415-331-6200 • info@marottayachts.com • www.marottayachts.com

See at: [www.marottayachts.com](http://www.marottayachts.com)



### 46' HYLAS, 2002

Center cockpit cutter. Spectacular performance cruiser. Beautifully maintained, top-of-the-line gear.

\$398,000

See at: [www.marottayachts.com](http://www.marottayachts.com)



### 61' C&C, 1971

Beautifully laid out; reportedly more than \$250,000 spent on her over the past 10 years.

\$269,000

See at: [www.marottayachts.com](http://www.marottayachts.com)



### 41' SCEPTRE CUTTER, 1985

Updated throughout, professionally maintained, transferable Sausalito Yacht Harbor slip.

\$185,000

See at: [www.marottayachts.com](http://www.marottayachts.com)



### 48' ISLANDER SLOOP, 1985

Pacem has had two long-term owners since new; shows beautifully today. New sails.

\$179,000

See at: [www.marottayachts.com](http://www.marottayachts.com)



### 46' MORGAN 462, 1981

This robust center cockpit cruiser has been thoroughly updated and is ready for Mexico.

\$146,000

See at: [www.marottayachts.com](http://www.marottayachts.com)



### 31' PACIFIC SEACRAFT CUTTER, 1989

Shows very nicely. Always professionally maintained local boat with less than 400 hours on Yanmar diesel. Radar, chartplotter, dodger, wheel. Transferable Sausalito YH slip.

\$89,000

See at: [www.marottayachts.com](http://www.marottayachts.com)



### 53' ISLANDER, 1979

Over \$100,000 spent over past several years on this vessel. Owner is motivated to sell IMMEDIATELY.

\$89,000

See at: [www.marottayachts.com](http://www.marottayachts.com)



### 43' BENEteau 430, 1992

Three stateroom, very clean, never cruised or chartered. Transferable slip. Turn key package.

\$89,000

See at: [www.marottayachts.com](http://www.marottayachts.com)



### 38' CABO RICO CUTTER, 1977

Extensively updated, clipper-bowed, Crealock-designed beauty. New teak decks.

\$82,000

See at: [www.marottayachts.com](http://www.marottayachts.com)



### 37' BENEteau 370, 1991

Very popular model, never cruised or chartered, just detailed, shows very nicely, competitive price.

\$63,500

See at: [www.marottayachts.com](http://www.marottayachts.com)



### 34' SABRE, 1984

Fixed keel. Never cruised, freshwater boat with \$40,000+ in improvements, Sausalito Yacht Harbor slip.

\$59,000

See at: [www.marottayachts.com](http://www.marottayachts.com)



### 45' STARRATT & JENKS, 1977

Nice aft cockpit sloop with new Yanmar diesel (\$30,000 project). Great value cruiser or liveaboard.

\$59,000

See at: [www.marottayachts.com](http://www.marottayachts.com)



### 30' BABA, 1982

Maintains crew for extended passages without sacrificing qualities of a great singlehander or weekender.

\$59,000

See at: [www.marottayachts.com](http://www.marottayachts.com)



### 41' TARTAN, 1975

S&S designed U.S.-built performance classic in fine shape, sails like a witch, very competitive price.

\$55,000

See at: [www.marottayachts.com](http://www.marottayachts.com)



### 32' ERICSON, 1989

Never cruised, and with \$18,000 spent on her in last 18 months, Heyoka shows much newer than her age.

\$44,000

See at: [www.marottayachts.com](http://www.marottayachts.com)



### 36' CATALINA, 1986

One of the most popular 36-ft sailboats ever built. Has had only two owners, shows nicely. Motivated owner.

\$39,000

at 100 BAY STREET • SAUSALITO • CALIFORNIA 94965 since 1946



# NORPAC YACHTS

THE BOAT MARKET IS UP - TIME TO RE-BOAT!

1150 Brickyard Cove Rd., B9, Pt. Richmond, CA 94801  
 (510) 232-7200 • FAX (510) 232-7202  
 email: info@norpacyachts.com

PLEASE SEE  
[www.norpacyachts.com](http://www.norpacyachts.com)  
 FOR MORE



**40' CLASSIC DANISH KETCH** by Aage Utzon, NA, built by Egon Nielsen... better provenance cannot be had. New rigging, great sails, new canvas & full cover, radar, low hrs. dsl., new cushions, copper riveted hull, recent Mex. vet. A sweet Valkyrie under sail. Asking **\$44,950**



**46' LAKE UNION CLASSIC CRUISER**, 1930. Restored/rebuilt, excellent cond., new dsls, new genset, rewired/reframed/refastened, radar, MORE! She could cruise to Seattle tomorrow. Premium covered Marin berth. Dsl cabin heat. Great liveaboard/cruiser. Asking **\$69,995**



**48' GRAND BANKS** Trawler LRC. Aft master S/R, twin diesel, FB & PH helms, classic mahogany in BEAUTIFUL condition. Onan, fully loaded galley, 3 heads, shower & tub, inflatable dinghy w/ motor, swim platform, steadying sails, radar, MORE! Asking **\$115,000**



**35' MERIDIAN 341** Barely used (less than 230 hrs), she's ready for all the pleasures the Bay, Delta and Coasts have to offer, while maintaining luxury and performance expected from Meridian. Meticulously maintained; she's an exceptional value. Asking **\$169,000**



**40' BRISTOL Sloop**. *Kokua III* is loaded and in excellent condition. Thoroughbred Ted Hood design built by Bristol Yachts, RI. Exquisite interior, comfort and seaworthiness. Radar, plotter, AIS, etc. Wheel, full dodger & MORE! This is the one you've been waiting for. Asking **\$69,900**



**30' HUNTER Sloop**. She is in wonderful condition; super clean and super nice. Just a really great boat that is equipped and has been cared for correctly. Yanmar diesel, wheel, roller furling, plotting GPS and MORE! *Harmony* is a GREAT VALUE at... Asking **\$14,000**



**SCHOONER** by J.G. ALDEN (design #309). 43' LOD. Oh she just seems perfect. Cold-molded (original by Goudy & Stevens, 1930). TOTAL RESTORATION reported, modern diesel. Gorgeous below, virtually everything to modern standards. Asking **\$84,950**



**40' X-YACHTS X-119 HIGH-PERFORMANCE** sloop. Renowned Danish performance cruiser/racer. Loaded with gear & high tech sails. Proven bluewater cruiser & race winner. **\$109,000**



**24' BRISTOL CUTTER**. These sturdy 'pocket cruisers' have earned themselves an admirable bluewater reputation. Equipped right: 3-axle HD trailer, 4-stroke engine, vane self-steering, F-10 heater, new dark green hull, new rigging, solar & MORE! Asking **\$13,950/offers**



**35' ERICSON MkII** Sloop. Solid example of this great Bruce King design. Excellent cruiser, good Atomic 4, 13 Barent winches, wheel, RF, 2 spinnies, good inventory, refig, shower, double spreader rig & MORE! Asking **\$27,950**

## Visit us at BEAUTIFUL & FRIENDLY Brickyard Cove Marina

- SAIL**
- 100' MEGA SLOOP Custom Offshore Performance Cruiser. Comfort & luxury, spacious, sleeps 17, loaded and near new. GREAT CHARTER POTENTIAL!!! ..... Try 885,000
  - 58' ALDEN Boothbay Ketch. Center PH cockpit, aft S/R, dsl, heavy glass, world cruiser. AWESOME! ..... Asking 268,950
  - 54' HERRESHOFF center cockpit ketch. F/G, dsl, loaded bluewater cruiser. Asking 199,500
  - 41' CT-41. Exquisite example of this revered Garden design with many custom features. Fiberglass, big diesel, teak deck, cabin heat & fireplace, tiled shower & head, gorgeous interior, alum. spars, full galley, refrigeration and much MORE! MUST SEE. Asking 78,950
  - 38' FARALLON CLIPPER #14 by Stephens Bros. Classic Master Mariners winner in outstanding condition ..... Asking 45,000
  - 36' ISLANDER Sloop. Diesel, wheel, furling, self-tailers ++.....REDUCED! 29,950
  - 35' MAGELLAN Sloop by American Marine. Diesel, covered liveaboard berth in Marin. A BARGAIN! ..... Asking 11,500
  - 32' NANTUCKET Clipper Mk III Yawl. Diesel, fiberglass..... 14,950/obo
  - 30' GARY MULL Sloop *THE SHADOW*, by Eason Boat Works. Famous SF Bay racer completely rebuilt in near new or better condition. Diesel, excellent cold-molded construction. Ready to cruise/race and WIN! ..... Asking 74,950
  - 30' RAWSON Cutter. Low hours diesel. Diesel range, much recent upgrading. Berth in Seattle's FRESH WATER Lake Washington w/sea access. New batteries, some new equipment still in box. Light/med Springtime cosmetics due. Unusually robust fiberglass construction. Solid & reliable Pacific Northwest cruiser with decades of fun & adventure ahead of her. REDUCED! ..... 13,950/offers
  - 30' RAWSON. Rare hard dodger model, diesel, furling, strong & more..... 24,850/obo
  - 30' ARGONAUTA TRI: Folding/trailerable w/ trailer. Amazing fast offshore cruiser. Mexico today, up I-5 to Canada 2 days later or just sail anywhere. Health forces sale....29,450/obo
  - 27' CANADIAN SAILCRAFT SC-27. Just refit & refinished. Beautiful! Dsl, MORE!.... 17,950
  - 27' O'DAY 272 pocket cruiser. Furling, dodger, clean & MORE! Trailer avail.... 7,950/offers
  - 26' CONTESSA Sloop. High quality European pocket cruiser..... Asking 9,950
- POWER**
- 130' CAMCRAFT Passenger Ship. Certified for 33 passengers overnight. Booked for the season. Virtual turnkey: Money and opportunity, working PNW..... 2,200,000

100' STEEL TUG with beautiful Sausalito berth. Great YTB, operational, fantastic opportunity, loads of potential and value!..\$44,950/obo

100' Steel HIGH ENDURANCE Adventure/Charter Ship in Northern Gulf of Mex. Just REPOSSESSED. Great vessel. A great opportunity! Reduced by more than \$3/4 Million. MOTIVATED! .... Bank Now Asking 500,000

85' CLASSIC TUG, '23 Vancouver Shipyard. Recent CAT V-12 repower. Massive, beautiful and seaworthy. Perfect for Classic Tug Yacht ..... 124,950/offers

62' ELCO 1926 CLASSIC MOTORYACHT. Twin dsl, gorgeous, elegant, comfortable. GREAT LIVEBOARD CRUISER. Must see! REDUCED! Offers encouraged!... 124,950

50' STEPHENS 1928 Classic. Twin dsl, F/B, part. restored & operational... Asking 80,000

48' DUTCH CANAL Barge. Beautiful & comfortable Sausalito liveaboard. Steel, diesel power. MUST BE SEEN! REDUCED. Asking 178,000

45' STEPHENS 1929 classic. Beautiful Gatsby-era motor yacht waiting to transport you back to the days of yachting in the grand style..... Try 75,000

45' S.F. BAY CHARTER BOAT w/established & unique business. Owner retiring. COI for 49 passengers. America's Cup is coming - here's your chance ..... Asking 295,000

43' MATTHEWS, '65, diesel. A gem! Loaded and beautiful..... Asking 69,450

42' GRAND BANKS Tvl. Aft cabin, F/B, Onan, twin dsls, radar. Excellent. REDUCED!..79,500

40' STEEL Fast-Utility vessel. Twin 671-N diesels, sandblasted and epoxied in & out, ex-USCG, MUCH potential.... Asking 12,950

36' SEA RAY 360 aft cabin fly bridge express. Twins. Nice & a GREAT VALUE. Asking 34,950

35' ROUGHWATER, 1974. Fiberglass, single diesel, completely outfitted, excellent condition. Owner motivated!..... 39,500

28' BAYLINER 2850 FLYBRIDGE SEDAN. New VOLVO/GM 300hp V8, economical & 30+MPH reported. Just completely refurbished & refitted to exceptional condition. .... Asking 19,950

27' FARALLON Pilothouse, '86. F/G, twin V8 5Ls, fast and seaworthy. Just detailed and very nice. .... Asking 39,950



**42' BERTRAM F/B MOTOR YACHT** Aft master strm, twin helms, twin dsl, Onan, PH, aft enclosure. Absolutely loaded w/gear & features incl radar, GPS, A/C & heat, washer/dryer & more! Beautiful & highly desirable vessel in good condition. Asking **\$99,500**



**ISLANDER 36**. Probably the MOST POPULAR CRUISING BOAT EVER BUILT! She's a good one: incomparable Alan Gurney design, dsl, dodger, roller furling, pulpits, double lifelines, pedestal wheel steering, double spreader rig, lines led aft for shorthanding, more. Asking **\$28,950**



**36' ALLIED PRINCESS** Sloop. Dsl, wheel, inverter, full keel w/cutaway, famously seaworthy & dependable design, fast & easy handling on & off the wind, exceptionally strong solid glass construction. An excellent cruising boat w/very comfortable layout. Outstanding value! Asking **\$29,950**



**30' CAPE DORY** Cutter. Carl Alberg, NA design: One of the finest smaller cruisers ever built. Famous for comfort, durability, seaworthiness and stout glass construction. Good sail inventory, diesel, autopilot, full lifelines and pulpits, enclosed head, wheel steering and MORE! Asking **\$27,950**

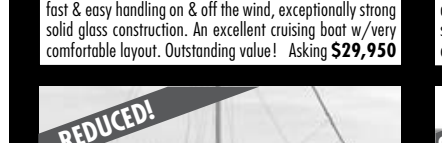

**44' STEEL** Canoe-stern cutter by Geo. Buhler/Fred Lagier & Sons. John Deere diesel. Stout steel construction. Awesome bluewater cruiser built to go to sea and stay there. Radar, GPS, etc. Here's your world beater! Asking **\$62,950**



**49' CUSTOM** Cold-Molded Ketch by Reliant. Beautiful Hankerson design. Powerful and seaworthy bluewater cruiser in great shape. Built '91. Yanmar diesel, furling, self-tailers, aux. genset, full galley, full electronics and MORE! MUST BE SEEN. Asking **\$99,950**

CALL (510) 232-7200 OR FREE (877) 444-5087  
 OR CALL GLENN DIRECT AT (415) 637-1181  
 FOR INFORMATION AND APPOINTMENTS





Treat yourself and your sweetheart to service at KKMI

HOME

SERVICES

LOCATIONS

STORE

YACHT SALES

GENERAL YARD

HAULS & LOADING

BOTTOM PAINTING  
& REPAIR

FINISH PAINTING  
& DETAILING

GEL COAT  
& FIBERGLASS

WELDING  
& FABRICATION

WOODWORKING  
& CABINETRY

SYSTEMS & EQUIPMENT

RIGGING

ENGINES

ELECTRONICS

RIGGING



KKMI operates the most complete rigging shop on the West Coast. With state of the art equipment and factory-trained craftsmen, we can fabricate rigging of all kinds, no matter if it is for your day-sailer, offshore cruiser or world-class racing yacht.

**LEWMAR**

**HARKEN**

**NAVTEC**

**FORESPAR**

**SAMSON**



## HERB CRANE

**IN PURSUIT OF:** A labor of love, that's what owning a boat means to the dedicated sailor. Whether it's how the smooth the bottom or sparkly the teak, the goal is the same...to keep their vessel as sound as can be. Truth be known, such dedication is rare and that's what makes Ron MacAnnan, the owner of the 82' sloop 'Pursuit' so unique. Not only has Ron owned the yacht for 52 of her 83 years, but much of the work he's done himself. When it comes to hiring the pros, he visits KKMI. Over the years the Team at KKMI has replaced some of her planking, installed 'dutchmans', hand brushed her gleaming white topsides and of course painted her bottom. All work performed under the direct supervision of 'Pursuit's' sometime vinegery yet loving owner. Like KKMI's facebook page and check out photos of this beauty out of the water.

PT. RICHMOND (510) 235-5564

SAUSALITO (415) 332-5564

WWW.KKMI.COM