

Latitude 38

VOLUME 409 July 2011

WE GO WHERE THE WIND BLOWS



Latitude 38

JULY 2011

VOLUME 409



Happy Independence Day!

Boaters in general have a very independent streak. We like to be self-sufficient and ready to go at a moment's notice. Join Grand Marina in celebration of the true meaning of this historically important holiday.

- Prime deep water concrete slips in a variety of sizes
- Great Estuary location at the heart of the beautiful Alameda Island
- Complete bathroom and shower facility, heated and tiled
- FREE pump out station open 24/7
- Full Service Marine Center and haul out facility
- Free parking
- Free WiFi on site!
- And much more...

DIRECTORY of GRAND MARINA TENANTS	
Bay Island Yachts	6
Blue Pelican Marine.....	162
The Boat Yard at Grand Marina ...	21
Lee Sails.....	150
Pacific Crest Canvas.....	49
Pacific Yacht Imports	13
Rooster Sails	166
UK-Halsey Sailmakers.....	



GRAND MARINA
 ANDERSON-ENCINAL

510-865-1200

Leasing Office Open Daily
 2099 Grand Street, Alameda, CA 94501
www.grandmarina.com

Singlehanded - Singular Results

PHOTO ERIK SIMONSON WWW.H2OSHOTS.COM



*Humdinger**

Well, you heard it here second. As covered in last month's Racing Sheet, Larry Olsen's Greene 35 trimaran, *Humdinger*, won this year's challenging Singlehanded Farallones race - first on elapsed time and also on corrected time.

Humdinger is fully "Powered by Pineapples," with a full-battened carbon main, a carbon jib and new Screecher. Larry came to Pineapple Sails for the sailmaker that he could count on to design and build the best sails for his unique boat.

Lilith, Tim Knowles' Wyliecat 39, came in first in class and third overall in the 58-mile race. *Lilith* is also "Powered by Pineapples."

So, if you need a humdinger of a mainsail, we build those. ...if you need a humdinger of a jib, we do those, too. ...and if you need a humdinger of a spinnaker, give us a call.

Our sails are carefully designed and constructed here in Alameda. Stop by or give us a call for a quote on new sails for your boat.

YOUR DEALER FOR: Musto foul weather gear, Dubarry footwear and Headfoil 2

Sails in need of repair may be dropped off at: West Marine in Oakland, Alameda, or Richmond.



PINEAPPLE SAILS

Phone (510) 522-2200

Fax (510) 522-7700

www.pineapplesails.com

2526 Blanding Ave., Alameda, California 94501

*Powered by Pineapples

BOAT LOANS

from



Trident Funding

*"a fresh
approach
from people
you can trust"*

In Northern California call
JOAN BURLEIGH
(800) 690-7770

In Southern California call
JEFF LONG
MARGE BROOKSHIRE
(888) 883-8634

www.tridentfunding.com

CONTENTS

subscriptions	6
calendar	12
letters	22
sightings	72
america's cup 34 sf bay	88
master mariners	92
the maiden & the <i>lost boy</i>	98
zen sailing chronicles	102
unsung heroes	106
the cost of cruising	112
max ebb: ready to roll	116
the racing sheet	120
world of chartering	130
changes in latitudes	138
classy classifieds	154
advertisers' index	165
brokerage	166

Cover: An AC 45 goes down the ol' coal mine without a pick.

Photo by Guilain Grenier/Oracle Racing

Copyright 2011 Latitude 38 Publishing Co., Inc.

Latitude 38 welcomes editorial contributions in the form of stories, anecdotes, photographs – anything but poems, please; we gotta draw the line somewhere. Articles with the best chance at publication must 1) pertain to a West Coast or universal sailing audience, 2) be accompanied by a variety of pertinent, in-focus digital images (preferable) or color or black and white prints with identification of all boats, situations and people therein; and 3) be legible. These days, we prefer to receive both text and photos electronically, but if you send by mail, anything you want back must be accompanied by a self-addressed, stamped envelope. **Submissions not accompanied by an SASE will not be returned.** We also advise that you not send original photographs or negatives unless we specifically request them; copies will work just fine. Notification time varies with our workload, but generally runs four to six weeks. Please don't contact us before then by phone or mail. Send all submissions to editorial@latitude38.com, or mail to Latitude 38 editorial department, 15 Locust Ave., Mill Valley, CA 94941. For more specific information, request writers' guidelines from the above address or see www.latitude38.com/writers.html.



YOUR FULL SERVICE YACHTING CENTER

New Yacht Sales

- Beneteau
- Island Packet
- Alerion
- Swift Trawler

Used Yacht Sales

- Power and Sail

Full Service Department

- New Installations
- Rigging Work
- Gelcoat Work
- Electronic Repairs
- Electrical Repairs
- Maintenance
- Brightwork
- Commissioning Services

Charter Yacht Placement

- Five Bay Area locations to choose from
- Award winning sailing schools and charter companies
- Exclusive Beneteau Fractional Ownership Program

ISLAND PACKET SUMMER SALE!

ISLAND PACKET 465



ESTERO 37



ISLAND PACKET 460



Great Savings on New Island Packets!

Savings of up to \$100,000

Island Packet 460
Retail: \$609,835 Sale: **\$475,000**

Island Packet 465
Retail: \$670,085 Sale: **\$529,000**

Estero 37
Retail: \$390,272 Sale: **\$299,900**

BENETEAU FIRST 30



Join us for some racing fun and to see the new Beneteau First 30 in action... Sign up to race on the First 30:

- Richmond Wednesday Nights
- Corinthian Friday Night Series
- YRA 2nd Half Opener July 23

Check dates online at www.passageyachts.com

Join us JULY 16 for our Midsummer Open House

- Sailboat Rides
- Boat Display
- Seminars
- RSVP for Rides

SELECT BROKERAGE AT OUR DOCKS



Moody 54, 2001
\$665,000



Beneteau 393, 2003
\$132,000



Island Packet 320,
1998 \$110,000



Island Packet 350,
1999 \$159,000



Beneteau 461, 2001
Reduced \$170,000



Beneteau 373, 2005
\$137,500

SAIL			POWER		
54' Moody	2001	\$665,000	37' Beneteau 373	2005	137,500
50' Hollman	1989	169,950	37' Pacific Seacraft	1984	129,000
47' Vagabond	1983	189,000	36' Beneteau 361	2000	105,000
46' Beneteau 461	2001	165,000	36' Beneteau First 36s7	1998	93,900
45' Beneteau 45f5	1991	139,000	36' Beneteau First 36s7	1998	99,500
44' Norseman 447	1984	225,000	36' Catalina	1989	53,900
42' Beneteau 423	2005	199,500	36' CS sloop	1988	62,500
42' Cascade	1971	39,900	36' Island Packet 350	1999	159,000
41' Tartan 4100	1996	219,000	35' Ericson	1978	24,900
40' Sea Wolf ketch	1968	68,000	35' C&C 35 Mk III	1983	49,000
39' Beneteau 393	2006	165,000	34' Catalina	1986	44,900
39' Beneteau 393	2003	132,000	34' Tiffany Jayne	1982	37,500
37' Tartan	1982	65,000	34' Aloha sloop	1984	49,000
			33' CS		33,900
			33' Hunter 33.5	1992	45,000
			33' Yamaha	1978	25,000
			32' Island Packet 320	1998	110,000
			32' J/32	1997	87,500
			28' Alerion	2002	80,000
			25' Cal 2-25 w/trailer	1979	11,900
			POWER		
			61' Mikelson SFPH	2001	990,000
			53' Navigator CPMY	1998	269,000
			42' Californian aft cabin	1987	99,500
			38' Pearson True North	2007	359,000
			34' Sea Ray 340	2006	134,900
			29' Shamrock	2001	120,000
			28' Bayliner 288 flybridge	2005	49,900

1220 Brickyard Cove Rd
Pt. Richmond, CA

p: 510-236-2633 f: 510-234-0118

www.passageyachts.com

1070 Marina Village Pkwy #101
Alameda, CA

p: 510-864-3000 f: 510-337-0565

BENETEAU ISLAND PACKET ALERION SWIFT TRAWLER BROKERAGE



Bay Island YACHTS

(510)
814-0400
Fax (510) 814-8765



yachtsales@bayislandyachts.com
www.bayislandyachts.com

TAYANA 48 DS



2003, \$429,000

MARINER 50 MS



1979, \$175,000

TAYANA 37



1981, \$72,500

C&C 41



1984, \$69,500

HUNTER 34

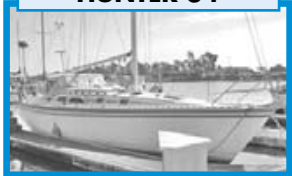

1986, \$35,000

C&C 32



1984, \$31,500

HUNTER 31



1987, \$31,500

NORWEST 33



1979, \$29,500

C&C 29



1985, \$23,900

NONSUCH 22



1987, \$21,500 includes trailer

ISLANDER 30



1979, \$18,900

In Grand Marina
2099 Grand Street
Alameda, CA 94501

YACHTWORLD.com

SUBSCRIPTIONS

**YOU CAN
NOW GO TO
www.latitude38.com
TO PAY FOR YOUR
SUBSCRIPTION
ONLINE**

eBooks email list. *Free!*

See www.latitude38.com to download the entire magazine for free! Our eBooks are in PDF format, easy to use with Adobe Reader, and also available in Issuu format.

Email: _____

Please allow 4-6 weeks to process changes/additions, plus delivery time.

Enclosed \$36 for one year Third Class Postage (Delivery time 2-3 weeks; Postal Service will not forward third class; make address changes with us in writing.)

Enclosed \$55 for one year First Class Postage (Delivery time 2-3 days.)

Third Class Renewal First Class Renewal (*current subs. only!*)

Gift Subscription *Card to read from:* _____

NOTE: FPO/APO (military), Canada, Mexico, and subscriptions going to a correctional facility are first class only. Sorry, no foreign subscriptions.

Name _____

Address _____

City _____

State _____

Zip _____

Phone: () _____ Email: _____

CREDIT CARD INFORMATION
Min. Charge \$12

MASTERCARD

VISA

AMERICAN EXPRESS

Number: _____

Exp.: _____

csv: _____

INDIVIDUAL ISSUE ORDERS

Current issue = \$6 ea.

Back Issues = \$7 ea. MONTH/YEAR: _____

DISTRIBUTION

We have a marine-oriented business/yacht club in California which will distribute copies of *Latitude 38*. (Please fill out your name and address and mail it to the address below. Distribution will be supplied upon approval.)

Please send me further information for distribution outside California

Business Name _____

Type of Business _____

Address _____

City _____

State _____

Zip _____

County _____

Phone Number _____

Latitude 38

"we go where the wind blows"

Publisher/Exec. Editor Richard Spindler richard@latitude38.com ext. 111
Associate Publisher..... John Arndt..... john@latitude38.com ext. 108
Managing Editor Andy Turpin andy@latitude38.com ext. 112
Editor LaDonna Bubak ladonna@latitude38.com ext. 109
Racing Editor Rob Grant rob@latitude38.com ext. 105
Contributing Editors John Riise, Paul Kamen
Advertising Sales John Arndt john@latitude38.com ext. 108
Advertising Sales Mike Zwiebach mikez@latitude38.com ext. 107
General Manager Colleen Levine colleen@latitude38.com ext. 102
Production/Web Christine Weaver chris@latitude38.com ext. 103
Production/Photos..... Annie Bates-Winship annie@latitude38.com ext. 106
Bookkeeping..... Penny Clayton..... penny@latitude38.com ext. 101
Directions to our office..... press 4
Subscriptions..... class@latitude38.com press 1,4
Classifieds class@latitude38.com press 1,1
Distribution..... distribution@latitude38.com press 1,5
Editorial editorial@latitude38.com press 1,6
Calendar calendar@latitude38.com
Other email..... general@latitude38.com

Please address all correspondence by person or department name
15 Locust Avenue, Mill Valley, CA 94941 • (415) 383-8200 Fax: (415) 383-5816
www.latitude38.com



THE NEW 2011 JEANNEAU 409
"EUROPEAN BOAT OF THE YEAR"
FIRST ONE SOLD WITHIN A WEEK!
NEXT ONE ARRIVES IN JULY 2011

Exclusive Dealer for Jeanneau, Hunter and Caliber Yachts
 See all of our listings at www.cruisingyachts.net

New In Stock

2011 JEANNEAU 42 DS
Strikingly beautiful inside and out

New In Stock

2011 HUNTER 45 DS
New and innovative throughout

2009 HUNTER 50 CC
 Asking \$425,000

1991 STOREBRO 50
 Asking \$225,000

2005 JEANNEAU 49
 Reduced \$299,000

2002 HUNTER 466
 New Listing \$204,500

1988 KROGEN 42
 Reduced \$129,000

2007 BENETEAU 423
 Asking \$188,400

1998 HUNTER 410
 New Listing \$118,750

2000 JEANNEAU 40
 Reduced \$145,000

2005 BENETEAU 373
 Reduced \$137,000

2006 HUNTER 36
 Asking \$132,500

2004 HUNTER 36
 Our Trade-in! \$120,000

2007 BENETEAU 343
 Reduced \$105,000

We are California's largest used sailboat broker with 6 waterfront locations throughout California. We have the resources to get your yacht SOLD!

San Diego
 (619) 681-0633
Newport Beach
 (949) 650-7245

Alameda
 (510) 521-1327
Sausalito
 (415) 332-3181

Marina del Rey
 (310) 822-9400
Oxnard
 (805) 791-2082

WWW.CRUIISINGYACHTS.NET

FARALLONE YACHTS



Catalina  **Yachts**

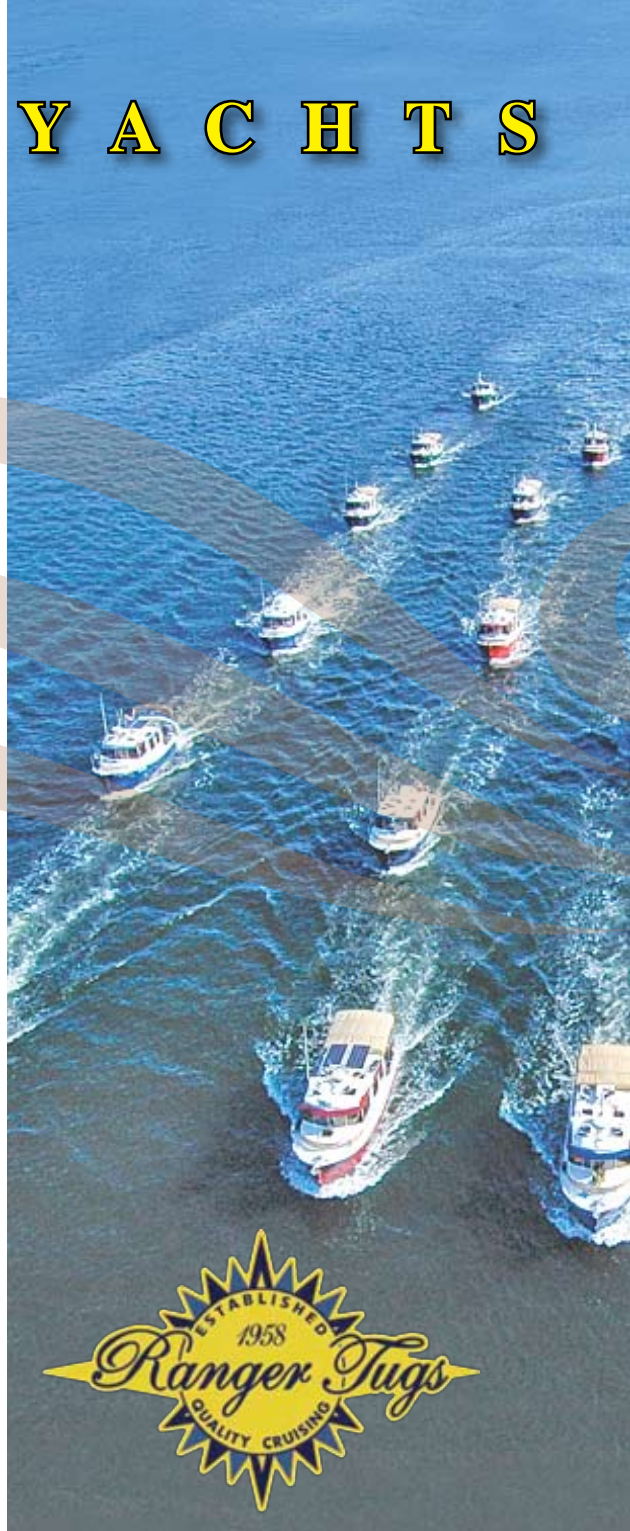

IT'S TIME TO BUY! WALK OUR DOCKS DURING OPEN BOAT WEEKEND JULY 9-10

New Catalina Yachts in Stock

Catalina 470, 2012 **NEW MODEL YEAR!**

Catalina 445, 2010 **NEWLY DISCOUNTED!**

Catalina 355, 2011 **AT OUR DOCKS NOW!**

Preowned Catalina Yachts at Our Docks

Catalina 470, 1999	\$230,000
Catalina 42 MkII, 2005	210,000
Catalina 42, 1992	119,900
Catalina 36 MkII, 2005	149,000
Catalina 36 MkII, 1999	89,500
Catalina 36, 2001	109,000
Catalina 34, 2007	129,900

Catalina 34, 1998	80,000
Catalina 32, 2002	81,995
Catalina 30, 1984	26,000

Preowned Sailing Yachts at Our Docks

Hans Christian 43, 1989	\$157,000
Beneteau Oceanis 373, 2005	139,000
C&C 38, 1979	49,250
Hunter 34, 1984	LET'S MAKE A DEAL! 34,000
C&C 32, 1980	34,000
Hunter Vision 32, 1990	40,000
Hunter 310, 2007	79,900
Hunter 306, 2002	40,000

Nonsuch 30, 1981	40,000
Rustler 24, 2009	50,000
Corsair 24-750, 2006	39,950

New Ranger Tugs in Stock (base price)

Ranger 29 Tug, 2011	\$229,937
Ranger 27 Tug, 2011	NEW MODEL! 159,937
Ranger 21-EC Tug, 2011	49,937

Preowned Ranger Tugs at Our Docks

Ranger 25 Tug, 2010	LET'S MAKE A DEAL! 139,950
Ranger 25 Tug, 2009	LET'S MAKE A DEAL! 125,900

Preowned Power Yachts

Regal 19, 2008	LET'S MAKE A DEAL! 21,950
----------------------	----------------------------------

W E L C O M E S T A R T A N !



WWW.FARALLONEYACHTS.COM

Farallone Yacht Sales is proud to represent three of the finest, Made in America boat brands available today. Tartan Yachts has an enviable 50-year history of producing elegant performance cruisers for the discriminating yachtsman. We welcome Tartan into the Farallone family and invite you to learn more at www.faralloneyachts.com.



Celebrate Independence Day with a Made in America yacht from Farallone!



1070 Marina Village Pkwy
Alameda, CA 94501
(510) 523-6730

2801 West Coast Hwy
Newport Beach, CA 92663
(949) 610-7190

From San Diego, CA
Call
(619) 523-6730

Yachtfinders/Windseakers

in the heart of
San Diego's boating community

2330 Shelter Island Dr. # 207, San Diego, CA 92106

info@yachtfinders.biz

www.yachtfinders.biz

(619) 224-2349

Toll Free (866) 341-6189

#1 Selling Brokerage on the
West Coast in 2010!
Professionally staffed
and open every day!



58' FARR, '87 **\$325,000**
\$60,000 price drop makes this one of the most attractive performance cruisers on the market today! This Farr 58 is ideal for shorthanding.



56' FORMOSA CC, '81 **\$349,900**
Seriously for sale... bring offers! Few vessels compare to her beauty, style and seaworthiness. Extensive 2005 refit and she has had light use since.



45' TRITON PACIFICA, '74 **\$84,000**
\$5,000 price reduction! Complete engine rebuild in January 2010! A large family or group of friends can travel in comfort on this heavily constructed cruiser.



43' GULFSTAR CC, '79 **\$79,900**
Her pedigree as a proven cruiser provides the cure for those in need of visiting those faraway places. Just add some equipment, some food and clothing.



41' NEWPORT CUSTOM, '77 **47,500**
She is truly unique and needs to be seen to be appreciated! She has a sleek, traditional appearance and is built to withstand the rigors of offshore sailing.



41' BENETEAU OCEANIS 411, '99 **\$144,900**
This popular two-stateroom Beneteau Oceanis 411 is in Bristol condition and has been appropriately upgraded and equipped by a knowledgeable buyer.



39' CAVALIER, '82 **\$79,000**
A great reputation as good offshore cruising boats. Very attractive interior, great layout. Factory non-skid decks and original teak-S/S stern pulpit seats.



38' HANS CHRISTIAN MKII, '79 **\$89,500**
A little beamier and heavier than the Traditional version, providing greater fuel & water capacity while maintaining excellent seakeeping abilities. 47' LOA.



36' ISLANDER, '73 **\$32,000**
These boats enjoy an excellent reputation. New paint on non-skid decks and house in 2008. She's had only three owners since the hull was laid up.



33' HUNTER, '06 **\$89,500**
Good sailing performance without sacrificing one inch of interior space, resulting in the ideal mid-size cruiser that also has an entertainment-ready cockpit.



31' CORSAIR 31R AFT CKPT, '99 **\$92,000**
Minimum interior, rotating carbon mast, extensive sails - and an aluminum double-axle trailer. She was built as the factory race boat. *GO FAST!* in this hot rod!



30' CATALINA MKII, '87 **\$29,000**
Wonderfully maintained, clean, neat and tidy are some of the words that come to mind as you step aboard *After All*. She's a great example of 'turn-key'.



PV Yachts
La Paz Yachts
Mazatlán Yachts
San Carlos Yachts

MAZATLAN

Ray Watson & Jeannette Sarrasin, Mazmarine@aol.com
Toll free US/CAN: 1 (888) 716-7430
Phone/FAX: 011 52 (669) 913-3165

LA PAZ

Mike Rickman & Shelly R. Ward, LaPazYachts@aol.com
Toll free US/CAN: 1 (877) 245-9689
Phone/FAX: 011 52 (612) 123-1948

PUERTO VALLARTA

PVYachtSales@aol.com
Toll free US/CAN: 1 (866) 573-1303
Phone/FAX: 011 52 (322) 297-4639

SAN CARLOS

Don Brame, Denny Grover, Will, Sancarlosyachtsales@gmail.com
Toll free US/CAN: 1 (866) 208-0263
Phone/FAX: 011 52 (622) 226-0037



68' QUEENSHIP MY, 1999...\$849,000



65' FERRETTI MY, 1997...\$849,000



47' CHEOY LEE LRC, 1972...\$85,000



52' TAYANA CC CUTTER, 1987...\$262,000



45' F-P CASAMANCE, 1988...\$189,000



42' HUNTER 420, 2000...\$134,500



40' CALIBER LRC CUTTER, 1998...\$199,500



38' IRWIN CUTTER, 1986...\$69,900



37' ISLAND PACKET 370, 2004...\$330,000



37' HALLBERG-RASSY SLOOP, 2006...\$379,900



36' CAPE DORY, 1979...\$59,000



26' HAKE YACHTS SEAWARD RK, 2006...\$38,917

San Francisco's yacht broker since 1969 ~ celebrating our 42nd year!

Cityyachts YACHTS AND THE CITY



45' Spaulding Sloop, 1961
\$79,000



Jeanneau 40, 2005
Boat shows like new. \$169,000



36' Catalina MkII, 2002
\$112,000



Beneteau 370, 1991
\$79,000



Catalina 42, 1989
3 cabin \$99,500



33' Hunter Sloop, 1980
\$29,900



46' Moody, 2000
\$350,000



30' Royal Systems Yacht, 1965
\$50,000 • 40-ft SF Berth



Jeanneau Deck Salon 49, 2006
\$425,000



35' J/105, 1994
\$69,000



30' Wooden Classic, 1960
Tore Holm Design \$37,000



Sea Ray 390, 1985
45-ft San Francisco Berth

10 MARINA BL. • SAN FRANCISCO, CA 94123 • Toll Free: 877-444-5091 • 415-567-8880

FAX (415) 567-6725 • email: sales@citysf.com • website: www.citysf.com



PLEASE VISIT OUR FUEL DOCK AT GASHOUSE COVE MARINA • OPEN 7 DAYS A WEEK • 9AM TO 5PM

WHALE POINT MARINE & HARDWARE CO.

A FAMILY OWNED & OPERATED BUSINESS FOR THREE GENERATIONS
ACE Hardware
MARINE PARTS & ACCESSORIES, PLUS A COMPLETE HARDWARE STORE

Go to WhalePointMarine.com for additional discounts!

MAGMA BBQ

Perfect BBQ for a Sunday night dinner on your boat. Stainless steel. Mounts easily with optional mount to your boats rails.



Charcoal: Whale Pt. **\$129⁹⁹**
 Propane: Whale Pt. **\$179⁹⁹**
 Rail Mount: Whale Pt. **\$42⁹⁹**

GILL Deckhand Gloves



Gill - present quality in sailing gear. Sizes: S, L & X.
 List \$21.99 • **NOW \$19⁹⁹**

FORCE 10

3 Burner Propane Stove



FORCE 10
 Model 63351
 3-burner

NOW \$1239⁰⁰
 Model 63251: 2-burners
NOW \$1199⁰⁰

DELUXE BOSUN'S CHAIR

Hard bottom seat. Large SS D rings let you snap in shackle and tie in a safety line.



NOW \$89⁹⁹

Z-SPAR PETIT Flagship Varnish

Highest UV protection available. Quart



Pint: List \$29¹⁶
NOW \$18⁹⁹
 Quart: List \$49⁹⁹
NOW \$32⁹⁹

Z-SPAR PETIT Bottom Paint B-90

Red, blue or black



Gallon
NOW \$169⁹⁹

Quart
NOW \$59⁹⁹

FENDERS 4 Pack

5.5" x 20"



NOW \$45⁹⁹

INTERLUX Brightside

Single-part Polyurethane



Quart
 List \$49.46
NOW \$34⁹⁹

205 Cutting Blvd, Corner of 2nd, Richmond
510-233-1988 • FAX 233-1989

Mon-Sat: 8:30am - 5pm • Sun: 10am - 4pm • whalepoint@acehardware.com

Go to WhalePointMarine.com for additional discounts!

CALENDAR

Non-Race

July 1-Oct. 31 — 'Mapping the Pacific Coast: Coronado to Lewis & Clark' world-class exhibition at San Francisco Maritime National Historical Park. Info, www.nps.gov/safr.

July 3-31 — Free sailing at Pier 40 every Sunday courtesy of BAADS. Info, (415) 281-0212 or www.baads.org.

July 4 — Celebrate Independence Day at Barron Hilton's Fireworks Extravaganza at Mandeville Tip in the Delta.

July 4 — Aeolian YC Open House & BBQ. No suit and tie required! Info, www.aeolianyc.com.

July 6-27 — Wednesday Yachting Luncheon Series at St. Francis YC, 12-2 p.m. Enjoy lunch and a dynamic speaker every Wednesday for less than \$20. All YCs' members welcome. More info under the 'Events' tab at www.stfyc.com.

July 7, 9, 14, 21, 23, 28, 30 — Sail aboard San Francisco Maritime National Historic Park's scow schooner *Alma*. Learn the Bay's history on this 3-hour voyage, leaving Hyde St. Pier at 1 p.m. \$40 adults, \$20 kids 6-15. Info, www.nps.gov/safr.

July 8-10 — 29th Annual Catalina Yachts Rendezvous at Two Harbors, Catalina Island. Info, www.catalinayachts.com.

July 9 — Classic Car & Yacht Show at Marin YC, 11 a.m.-4 p.m. Info, www.marinyachtclub.com.

July 9-10 — America's Boating Course by Carquinez Sail & Power Squadron at Vallejo YC, 9 a.m.-4 p.m. \$40. Info, www.carquinez.org/public_courses.html or (707) 55-BOATS.

July 10 — Pacific Cup Race Offshore Academy #1, the first in a series of seminars leading up to next summer's race, at Berkeley YC, 12-5 p.m. Learn about the race and much more. Open to all. \$20 (\$18 for PCYC members). Info, www.pacificcup.org/seminars.

July 10 & 24 — Cal Sailing Club's free introductory sail at Berkeley Marina, 1-4 p.m. Info, www.cal-sailing.org.

July 14 — Howl at the full moon on a Thursday night.

July 14 — Single sailors of all skill levels are invited to the Single Sailors Association monthly meeting at Ballena Bay YC, 7:30 p.m. Info, www.singlesailors.org or (510) 233-1064.

July 14 — Sea of Cortez Cruising talk with the Emmons Family at San Jose SC, 7 p.m. Free. Info, scott@svjaneo.com.

July 15-17 — Annual Catalina Owners Rendezvous at Tradewinds Sailing School in Richmond's Marina Bay Yacht Harbor. Info, <http://raft.c380.org>.

July 16 — San Leandro YC Nautical Flea Market, 8 a.m.-3 p.m. Breakfast, BBQ & live music! Info, sanleandroyc.org.

July 16 — Splash Into Summer Open House at Lake Merritt Boating Center in Oakland, 1-3 p.m. Free rentals. Info, (510) 238-2196.

July 16 — Glen Cove Marina Jazz, Arts & Wine Festival, noon to dusk. Info, www.glencovermarina.net.

July 16 — Taste of the Delta at Windmill Cove Marina in Stockton, 1-4 p.m. Info, www.tasteofthedelta.com.

July 16 — 11th Annual Women's Sailing Clinic at Lake Tahoe, for beginning to advanced sailors. \$50 members, \$60 non-members. LTWYC, www.tahoewindjammers.com.

July 16-17 — America's Boating Course by Carquinez Power Squadron at Vallejo YC, 9 a.m.-4 p.m. \$50, includes lunch. Info, www.carquinez.org or (707) 55-BOATS.

July 21 — Sail Trim seminar, part of Sausalito YC's Third Thursday Seminar Series, 6:30-7:30 p.m. Free and open to the public. Info, www.sausalitoyachtclub.org/calendar/whats-happening.

July 30, 1844 — The New York YC, our country's first yacht club, was established on the schooner *Gimrack*.

July 30-31 — Benicia Fine Art, Wine & Jazz Festival. Info, www.beniciamainstreet.org.

TAYANA 48 DECK SALON



Models Available:

Tayana 54

Tayana 58

Tayana 64

Tayana 72

Check out this value: \$540,000 for a well-equipped Tayana 48 Deck Salon with Leisure Furl mainsail, electric winches, furling jib and staysail, genset, air/heat, refrigeration and freezer, windlass, ground tackle, washer/dryer, and Corian countertops. This includes delivery, cargo insurance, U.S. import duty, and commissioning, FOB Alameda, California. **Only two at this price!**

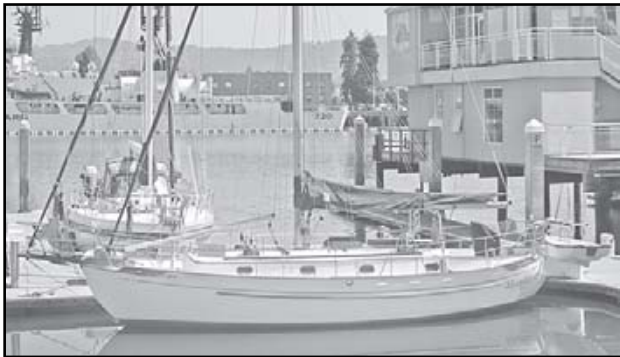

1984 TAYANA 37 CUTTER

This is the one you want. Perfect shape with lots of new upgrades and electronics!
\$119,000



1983 TAYANA 55 CUTTER

Beautiful Center Cockpit Cutter with three staterooms and plenty of room for family and friends. Recent LPU hull, Leisure Furl main, engine room. \$275,000



1998 TAYANA 48 CC

Beautiful teak interior with good storage throughout for all your cruising essentials. \$330,000



2005 TAYANA 48 CC

Mexico vet. In great shape and loaded with everything you need. \$435,000



2006 TAYANA 48 CC

Meridian has returned from cruising in excellent shape and is ready to go again. \$425,000



2001 HUNTER 380

Very clean with only 350 hours on Yanmar diesel. Furl Boom mainsail with electric winch. \$119,900



2000 BENETEAU 321

Excellent condition with low hours on Yanmar diesel. Air/heat, autopilot, plotter, bimini. \$79,000



1979 BABA 30

Classic bluewater cruiser designed by Robert Perry. Bristol condition and ready for her next captain. \$49,900



1984 LANCER 40 CC

Roomy center cockpit model. Recent refit includes new standing rigging, sails, and Volvo diesel. \$59,000



1981 TAYANA 42 CC

Beautiful custom teak interior that Tayana is known for. Reverse cycle air/heat, genset, AP, SSB, radar. \$119,500

Pacific Yacht Imports

2051 Grand Street, Alameda, CA 94501

www.pacificyachtimports.net

We're at Grand Marina

Dave Wolfe • Neil Weinberg

Tel (510) 865-2541 Fax (510) 865-2369

tayana@mindspring.com

NEW J/111



Frank Sloodman's J/111 *Invisible Hand*
Photo ©2011 Erik Simonson/www.h2oshots.com

First in Class, Spinnaker Cup
Second in Class, Cabo Race
Two Offshore Races,
Two Strong Finishes
Get in on the fastest fleet
coming to the Bay.
The new J/111.



SAIL
California

Alameda
(510) 523-8500
norman@sailcal.com
steve@sailcal.com

www.sailcal.com

CALENDAR

July 30-Aug. 5 — *Latitude 38's* Delta Doo Dah 3D, a laid-back rally to the balmy Delta waters. Follow the event at www.deltadoodah.com.

July 31 — 'How to Get Your Captain's License' by C Quest Marine at San Jose West Marine, 3 p.m. Info, (408) 246-1147.

Aug. 5-7 — Beneteau Owners Rendezvous at Catalina's Two Harbors. Info, www.scyachts.com.

Aug. 6 — Flea Market & Maritime Day Celebration at Galilee Harbor in Sausalito, 8 a.m.-6 p.m. Info, (415) 332-8554 or www.galileeharbor.org.

Aug. 6 — Summer Water Festival at San Rafael YC, 1-5 p.m. Sailing demos, BBQ & live music! Info, (415) 484-5302.

Aug. 6 — Petaluma Music Festival. Info, www.petalumamusicfestival.org.

Aug. 12 — A Taste of Richmond gala party at Richmond YC, 6-8:30 p.m. Taste from the best of Richmond's restaurants, and support local charities. \$50. Info, www.richriv.com.

Racing

July 2 — 63rd Annual Boreas Race, Half Moon Bay to Moss Landing. Elkhorn YC and HMBYC, www.elkhornyc.com.

July 4 — Brothers & Sisters Regatta, a low-key lap around the two island groups followed by a BBQ and shoreside fun for the whole family. TYC, www.tyc.org.

July 4 — Independence Cup. SFYC, www.sfyf.org.

July 4-8 — 46th L.A. to Honolulu Race, better known as the TransPac, starts. Info, www.transpacrace.com.

July 6 — SSS LongPac, a qualifier for next summer's Singlehanded TransPac. For more info, contact AJ Goldman at (650) 867-2145 or ajgoldman@scus.org.

July 9 — YRA-OYRA Jr. Waterhouse. RYC, www.richmondyc.org.

July 9 — Silver Eagle Long Distance In-The-Bay Race, with a shorter course for boats rating 150 or above. IYC, racing@iyc.org or www.iyc.org.

July 9 — Jack & Jill Race. SSC, www.stocktonsc.org.

July 9 — Trans-Tahoe Race, generally featuring either too much wind or too little but always lots of fun. Tahoe YC, www.tahoeyc.com.

July 9 — Hart Nunes for Merces. SFYC, www.sfyf.org.

July 9-10 — Finn Masters NAs. EYC, www.encinal.org.

July 9-10 — Longboard SF Classic/UN Challenge. StFYC, www.stfyf.com.

July 9-10 — High Sierra Regatta for Centerboard Classes. Info, www.fresnoyachtclub.org.

July 12-16 — U.S. Windsurfing Nationals. BYC, www.berkeleyyc.org.

July 16 — 27th Annual Plastic Classic Regatta & Concours d'Elegance, for fiberglass boats designed at least 25 years ago. BVBC, www.bvbc.org or (415) 495-9500.

July 16 — Singlehanded Race. SSC, www.stocktonsc.org.

July 16 — Twin Island #2. SYC, www.sausalitoyachtclub.org.

July 16 — H.O. Lind #5 & 6. TYC, www.tyc.org.

July 16 — Angel Isl./Red Rock Race. VYC, www.vyc.org.

July 16 — 3rd Annual Westpoint Marina Regatta hosted by Sequoia YC. Info, www.sequoiayc.org or (650) 430-5567.

July 16-17 — BAYS #3/Summer Splash (which also acts as the Area G Bemis 420 qualifier). EYC, www.bayarea-youthsailing.com.

July 16-17 — Finn NorCal. SFYC, www.sfyf.org.

July 16-17 — PICYA Lipton Cup, the annual interclub all-star game. GGYC, www.picya.org.

July 16-17 — High Sierra Keelboat Divisions for Keelboat Classes on Huntington Lake. Info, www.fresnoyachtclub.org.

SAIL *California*

YOUR PERFORMANCE YACHT SPECIALISTS

ALAMEDA

1070 Marina Village Pkwy #108
Alameda, CA 94501
(510) 523-8500
FAX (510) 522-0641

SEATTLE

SAIL NORTHWEST
7001 Seaview Ave. NW #140
Seattle, WA 98117
(206) 286-1004

"The Fastest Sailboat Listings in the West!"



33' Back Cove, 2008
Cruise the Bay or Delta in style.
Asking **\$279,000**



Santa Cruz 52, 1998, Hula
Deep draft for cruising, buoy and offshore.
This boat has it all. Reduced to **\$449,000**



J/122, TKO
Ready to win the Big Boat Series again!
Reduced to **\$380,000**



Islander 36, 1972, Absolute
Best in fleet.
Asking **\$45,000**



Santa Cruz 52, Kokopelli
BBS, TransPac winner.
Asking **\$499,000**



40' Summit, 2008, Soozal
IRC super boat.
\$579,000



1D48, 1996, Chaya
Race ready.
Asking **\$125,000**



J/105s
We have 4 from
\$74,900



J/100, 2005, Brilliant
Race/cruise ready.
Reduced **\$96,000**

52' Santa Cruz, <i>Kokopelli</i>	\$499,000	39' Schumacher, '96, <i>Recidivist</i>	SOLD	34' MJM 34z, '05*.....	\$334,000
52' Santa Cruz, '99, <i>Renegade</i>	\$495,000	38' Sabre 386, '08, <i>Kuai</i>	SOLD	33' J/100, Hull #9, '05.....	Reduced \$96,000
52' Santa Cruz, '98, <i>Hula</i>	\$449,000	38' Sabre 38 Mk1, '84.....	SOLD	33' Back Cove, '08.....	\$279,000
52' TransPac with IRC mods, '03, <i>Braveheart</i> *..	\$499,000	36' J/109, '03*.....	\$189,000	32' J/32, '02, <i>Tango</i>	SOLD
48' J/145, Hull #9, '03*.....	\$675,000	36' Islander 36, '72, <i>Absolute</i>	\$45,000	32' Catalina 320*.....	\$59,000
48' 1D48, '96, <i>Chaya</i>	\$125,000	35' J/105, '01, Hull #405, <i>Swoosh</i>	SOLD	30' Peterson Half Ton*.....	\$27,500
47' Valiant, '81, <i>Sunchase</i>	\$110,000	35' J/105, '92, Hull #44, <i>Orion</i>	SOLD	29' MJM 29z, '07*.....	\$269,000
44' Kernan, <i>Wasabi</i>	SOLD	35' J/105, '99, <i>Life Is Good</i> *.....	\$74,900	28' Alerion Express, '06*.....	\$99,000
44' J/44, '93, <i>Halcyon Days</i> *.....	SOLD	35' J/105, '00, Hull #343, <i>Nirvana</i>	\$94,900	28' Alerion Express, '02*.....	\$72,500
44' Wauquiez 43 Pilot Station*.....	\$299,000	35' J/105, '00, Hull #347, <i>Bald Eagle</i>	\$99,000	28' Islander, '79*.....	\$16,900
43' J/130, '96*.....	\$184,000	35' J/105, '01, Hull #463, <i>Trickster</i>	SOLD	26' J/80, '01*.....	\$32,900
40' J/122, '07, <i>TKO</i>	Reduced \$380,000	35' J/105, '02, Hull #520, <i>Sea Room</i>	\$94,900	26' J/80, '04, <i>Heart Attack</i>	SOLD
40' Summit, '08, <i>Soozal</i>	\$579,000	35' J/35, '84, <i>The Boss</i> *.....	SOLD	26' Aquapro Raider, '02, enclosed hard top.....	SOLD
40' Avance, '85, <i>Caribou</i> *.....	SOLD	35' J/35C, '93*.....	\$89,000	20' Melges, '09*.....	\$45,000
40' Olson, <i>Elka</i>	SOLD	34' J/34, '85, <i>The Zoo</i> *.....	\$29,900		

* Denotes Seattle Boats

SAIL *California*

www.sailcal.com

email: norman@sailcal.com, steve@sailcal.com

DEALERS FOR THESE FINE YACHTS:

Santa Cruz
— YACHTS —

SUMMIT
YACHTS

J
BOATS

No Surprise!



Ocean Series Hydrostatic Inflatable Life Vests

For the safety you need and the comfort you want, inflatable PFDs are the way to go. There's just one problem with many inflatable PFDs—they don't know when to blow! A sudden squall or an errant wave can accidentally trigger their water-activated inflators while you're sitting safely aboard. But that won't happen with our Ocean Series Hydrostatic Vests. Their auto-inflation mechanism is triggered by pressure, not by moisture. So they won't inflate until you're actually in the water. But that's not the only reason to recommend them. They're tough, with a 420-Denier ripstop nylon cover. They have a soft neoprene Comfort Collar, handy pocket, safety whistle and SOLAS-rated reflective patches. The harness exceeds ISAF standards. But the most important advantage is that they provide 35lb. of positive buoyancy when you need it most—but only when you actually need it!

Without Harness – Model 8503674 **269⁹⁹**

With Harness – Model 8503682 **299⁹⁹**

 **West Marine®**

Contact us for all of your Rigging Needs!
888-447-RIGG

We have 17 stores in Northern California,
including our Alameda Sailing Superstore!

Visit westmarine.com to find the store nearest you.

CALENDAR

July 17 — Summer Series #2 on Fremont's Lake Elizabeth. Info, www.fremontsailingclub.org.

July 18-24 — Golden Gate Cup. GGYC, www.ggyc.org.

July 19-24 — Junior Windsurfing Worlds. StFYC, www.stfyc.com.

July 23 — Twin Island Race #2, a race around Alcatraz & Angel Island. SYC, www.sausalitoyachtclub.org/racing

July 23 — Summer #4. SeqYC, www.sequoiayc.org.

July 23 — North Bay Challenge #4. VYC, www.vyc.org.

July 23 — West Wight Potters Roundup on Monterey Bay. MPYC, www.mpyc.org.

July 23-24 — YRA 2nd-Half Opener. EYC, www.yra.org.

July 23-24 — SF Perpetual Challenge. SFYC, www.sfyyc.org.

July 26-Aug. 2 — Laser 4.7 Worlds. StFYC, www.stfyc.com.

July 29-30 — King Harbor Race, from Santa Barbara to Redondo Beach. SBYC/KHYC, www.khyc.org.

July 29-31 — Santana 22 Nationals hosted by Monterey Peninsula YC. Info, www.santana22.com.

July 29-31 — McNish Classic, for classics designed before 1952, held in the Channel Islands. PCYC, www.pcyyc.org.

July 30 — Singlehanded #3. SeqYC, www.sequoiayc.org.

July 30 — Tri-Island Race. RYC, www.richmondyc.org.

July 30 — PICYA's CHISPA/Youth Regatta. SeqYC, www.picya.org.

July 30 — Small Boat Summer #1. EYC, www.encinal.org.

July 30-31 — 505 Regatta. SFYC, www.sfyyc.org.

July 30-31 — Moseley Regatta. TYC, www.tyc.org.

July 31 — Women's Day Race on Lake Tahoe. LTWYC, www.windjammers.com.

July 31 — Summer Series #3 on Fremont's Lake Elizabeth. Info, www.fremontsailingclub.org.

Aug. 6 — YRA Summer 1. RYC, www.yra.org.

Aug. 6 — Singlehanded Sailing Society's Half Moon Bay Race. Info, www.sfbaysss.org.

Aug. 6-7 — BAYS Summer Series #4 for Optis, Lasers, C420s & CFJs. SFYC, www.bayarea-youthsailing.com.

Aug. 6-7 — El Toro Worlds at Pincrest. Info, www.eltoroyra.org.

Aug. 6-7 — Monterey Bay PHRF Championship. Elkhorn YC, www.elkhornyc.com.

Aug. 6-14 — Laser Master Worlds. StFYC, www.stfyc.com.

Aug. 7 — Gracie & George Regatta, a co-ed doublehanded featuring 'Gracie' on the helm. EYC, www.eyc.org.

Aug. 12-14 — Coronado 15 NAs. HMBYC, www.hmbyc.org.

Aug. 12-14 — El Toro Nationals. SCYC, www.eltoroyra.org.

Aug. 13 — Moonlight Marathon, a nighttime trip from South Bay to Angel Island and back. SeqYC, www.sequoiayc.org.

Aug. 13 — YRA Summer 2. YRA, www.yra.org.

Aug. 13 — North Bay Challenge #5. VYC, www.vyc.org.

Aug. 13-14 — J/120-IRC Regatta. SBYC, www.southbeachyc.org.

Aug. 13-14 — Richmond Riviera Regatta, a race series "with a conscience." Proceeds benefit local charities. Info, www.richriv.com.



COURTESY RYC

The Richmond Riviera Regatta is a race series "with a conscience."

Proceeds benefit local charities. Info, www.richriv.com.

Aug. 13-14 — Summer Keel. SFYC, www.sfyyc.org.

Aug. 27 — Great San Francisco Schooner Race, for schoo-

GARHAUER

MARINE HARDWARE

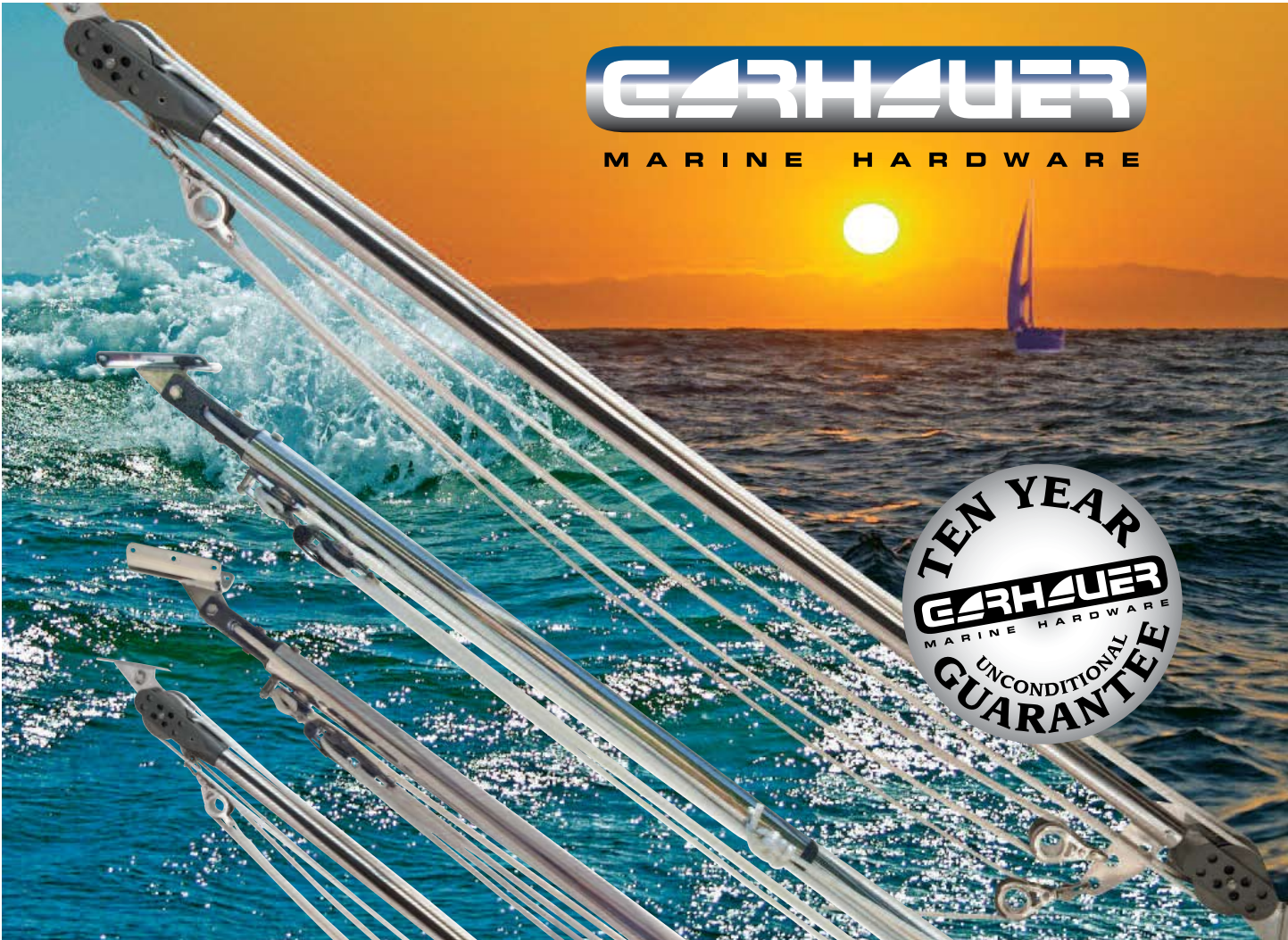

RV20-1 DX

Experience the extra level of mainsheet efficiency only a rigid boom can provide. Whether you are going downwind or beating in a blow, a Garhauer rigid boom will deliver optimum sail shape with less effort. You have a choice of aluminum and or stainless vang assembly with lightweight stainless steel blocks. Control lines can be led aft for easy cockpit adjustments. Best of all you can expect years trouble-free service, backed up by our 10 year unconditional guarantee.

Now sail with more confidence and spend less:

RV12-1 -boat size: 18-24 ft. Length: made to order.
 Tube diameter: 1-1/2" Custom fittings for mast & boom.
\$275.00 (usd)

RV18-1 - boat size: 28-34 ft.Length: made to order.
 Tube diameter: 2" Custom fittings for mast and boom.
\$435.00 (usd)

RV25-1

RV18-1

RV20-1 SL

RV20-1 SL -boat size: 28-44 ft. Length: made to order.
 Tube diameter: 1-3/4" Custom fittings for mast & boom.
\$495.00 (usd)

RV20-1 DX - boat size: 28-44 ft. Length: made to order.
 Tube diameter: 2" Custom fittings for mast and boom.
\$568.00 (usd)

RV25-1 - boat size: 45 ft. and up. Length: made to order.
 Tube diameter: 2-1/4" Custom fittings for mast & boom.
\$871.20 (usd)



1082 West Ninth St.
 Upland, CA 91786

Ph: (909) 985-9993
 FAX: (909) 946-3913

email: garhauer@garhauermarine.com
<http://www.garhauermarine.com>

We Do Rigging Right!



Superior rope and wire work for gunkholers to Grand Prix racers!

Now every sailor can get the same high quality work West Marine Rigging provides to over 20 of the nation's top boatbuilders. Whether you need new lifelines, halyards, sheets or anchor rodes, we do it all with top-quality materials, hardware and craftsmanship. Fast quotes, fast turnarounds and your satisfaction is guaranteed! Find out more at westmarine.com or your local West Marine store.

888-447-RIGG (7444)



Illustration courtesy of **HARKEN**

Custom Sheets, Guys & Halyards for popular One-Design Classes!

West Marine Rigging has high-quality, affordable rigging packages available for many of today's most popular boats. Call 888-447-7444 or visit westmarine.com for more information.

Scan the code with your Smartphone to shop our rigging products online.

Get the free mobile app at <http://getag.mobi>



West Marine®

Visit our stores! For the location nearest you, go to www.westmarine.com

CALENDAR

ners in Gaff and Marconi divisions. SFYC, www.sfyf.org.

Summer Beer Can Regattas

BALLENA BAY YC — Friday Night Grillers: 7/1, 7/15, 7/29, 8/12, 8/26, 9/9. Matt Schuessler, (925) 785-2740 or race@bbyc.org.

BAY VIEW BOAT CLUB — Monday Night Madness Spring: 7/25, 8/15, 8/22, 9/5, 9/19, 9/26 (make-up). Arjan Bok, (415) 310-8592 or bayviewracing@sbcglobal.net.

BENICIA YC — Thursday nights through 7/28. Info, www.benicia-yachtclub.com.

BERKELEY YC — Friday nights through 9/23. Paul Kamen, (510) 540-7968 or pk@well.com.

CAL SAILING CLUB — Year-round Sunday morning dinghy races, intraclub only, typically in Laser Bahias and JY15s. Email Gary and Alistair at racing_chair@cal-sailing.org.

CORINTHIAN YC — Friday nights through 9/2. Info, (415) 497-5411 or racing@cyc.org.

COYOTE POINT YC — Wednesday nights through 10/26. George Suppes, (650) 921-4712 or regatta@cpyc.com.

ENCINAL YC — Friday Night Spring Twilight Series: 7/22, 8/5, 8/19, 9/9, 9/23. Chris Hanson, (510) 301-2081 or rearcommodore@encinal.org.

FOLSOM LAKE YC — Wednesday nights: 7/6, 7/20, 7/27, 8/3, 8/10, 8/17, 8/24, 8/31, 9/7, 9/21. Info, www.flyc.org.

GOLDEN GATE YC — Friday nights: 7/1, 7/15, 7/29, 8/12, 8/26. Leslie Iacopi, (415) 931-3980 or lesliesailor2003@yahoo.com.

ISLAND YC — Friday Night Spring Twilight: 7/15, 7/29, 8/12, 8/26, 9/16. John New, (510) 521-2980 or iycracing@yahoo.com.

LAKE TAHOE WINDJAMMERS YC — Wednesday nights through 10/12. Steve Katzman, (530) 577-7715.

LAKE WASHINGTON SC — Thursday nights through August. Dan Clark, www.lwsailing.org.

LAKE YOSEMITE SA — Thursday nights through 8/25. Tom Cooke, tcookeatty1@yahoo.com.

MONTEREY PENINSULA YC — Sunset Series, Wednesday nights through September. Ray Ward, (831) 659-2401 or www.mpyc.org.

OAKLAND YC — Wednesday Night Sweet 16 Series: 7/13-8/31. John, (510) 366-1476 or j_tuma@comcast.net.

RICHMOND YC — Wednesday nights: 7/6, 7/13, 7/20, 7/27, 8/3, 8/10, 8/17, 8/24, 8/31, 9/7, 9/21, 9/28. Eric Arens, (510) 841-6022 or ericarens@comcast.net.

ST. FRANCIS YC — Wednesday Night Series: 8/3, 8/10, 8/17, 8/24, 8/31. Thursday Night Kiting Series: 7/14, 7/28, 8/4, 8/18, 9/1, 9/15. Friday Night Windsurfing Series: 7/1, 7/29, 8/5, 8/19, 9/2, 9/16, 9/30. Info, racemgr@stfyf.com.

SANTA CRUZ YC — Wet Wednesdays through 11/2. Greg Haws, (831) 425-0690 or greg@scyc.org.

SANTA ROSA SC — Monday Night Twilight Series: 7/11, 7/18, 7/25, 8/1, 8/8. Info, stevsars@sonic.net.

SAUSALITO YC — Tuesday Night Summer Sunset Series: 7/26, 8/9, 8/23, 9/6, 9/20. Dave Borton, (415) 302-7084 or race@sausalito-yachtclub.org.

SEQUOIA YC — Wednesday nights through 10/12. Steve Holmstrom, (650) 610-9501 or www.sequoiayc.org.

SHORELINE LAKE AQUATIC CENTER — Capri 14.2 racing every Thursday night during Daylight Saving Time. Info, (650) 965-7474. Laser racing (BYOB) every Wednesday night, May-October. Roger Herbst, rogerlaser@yahoo.com or (408) 249-5053.

SOUTH BEACH YC — Friday Night Series: 7/15, 7/22, 7/29, 8/5, 8/19, 8/26. Tad Sheldon, (408) 546-1240 or www.sbyc.org.

ORDER SAILS NOW FOR THE ROLEX BIG BOAT SERIES
CALL QUANTUM SAN FRANCISCO AT 510.234.4334

WHAT'S YOUR iQ?

It takes more than just blood, sweat and tears to win a race.
Sometimes it takes the perfect iQ.

Quantum iQ™ Technology has not only proven itself at the grand prix level of racing, it's also proven that racers at every level can get more satisfaction and enjoyment out of their sport than ever before.

The computational power of Quantum's iQ Technology® allows Quantum to custom design sails for every type of sailor and every sailing condition. Sails that will make your boat sail closer to the wind with reduced heel and less sail handling.

And provide more of the pure joy of sailing.

This technology was once only available to those with unlimited budgets. Now you just need the desire to bring out the best in yourself, and your boat.

**We can help you get ready for the Rolex Big Boat Series.
Call us today!**

follow us:   

QUANTUM SAN FRANCISCO

1230 BRICKYARD COVE | PT RICHMOND, CA 94801

TEL: 510-234-4334

SANFRANCISCO@QUANTUMSAILS.COM

LOFT HOURS: MONDAY – FRIDAY 9AM – 5PM
EVENINGS OR WEEKENDS BY APPOINTMENT.

 **QUANTUM**
SAIL DESIGN GROUP

WWW.QUANTUMSAILS.COM

Third Reef Gear



Men's Jacket & Bibs

Women's Jacket & Bibs

We've improved our Third Reef Foul Weather Gear!

For years, thousands of boaters have chosen our Third Reef waterproof gear for its unbeatable combination of quality, durability and value. Now we've made it even better! Using technically-advanced new fabric, Third Reef is now lighter, easier to move in and more breathable, yet still provides complete waterproof protection when you're on the water. We've also developed a version specifically to fit and function better for women. So now there are even more reasons to choose Third Reef. The world's best-selling gear!



We have 17 stores in Northern California, including our Alameda Sailing Superstore!
Visit westmarine.com to find the store nearest you.

CALENDAR

southbeachyc.org.

STOCKTON SC — Wednesday nights through 8/24. Patrick Felten, (209) 518-6371 or regatta11@stocktonsc.org.

TAHOE YC — Wednesday Night Beer Can Series through 8/31. Dan Hauserman, (530) 581-4700 or dan@ilovetahoe.com. Monday Night Laser Series: 5/30-8/29. Rick Raduziner, (530) 583-6070 or raduziner@sbcglobal.net.

TAHOE WINDJAMMERS YC — Wednesday nights through 9/21. Jerry, (530) 318-5210 or jerry.starkey@att.net.

TIBURON YC — Friday nights through 9/9. Ian Matthew, ian.matthew@comcast.net or (415) 883-6339.

VALLEJO YC — Wednesday nights through 9/28. Gordon Smith, (530) 622-8761 or fleetcaptainsail@vyc.org.

Please send your calendar items by the 10th of the month to calendar@latitude38.com. If you're totally old-school, mail them to *Latitude 38* (Attn: Calendar), 15 Locust Avenue, Mill Valley, CA, 94941 or fax them to us at (415) 383-5816. But please, no phone-ins! Calendar listings are for marine-related events that either are free or don't cost much to attend. The Calendar is not meant to support commercial enterprises.

July Weekend Tides

date/day	time/ht. HIGH	time/ht. LOW	time/ht. HIGH	time/ht. LOW
7/02Sat	0006/6.4	0657/-1.1	1416/4.9	1848/2.7
7/03Sun	0050/6.2	0753/-1.1	1452/5.0	1938/2.5
	LOW	HIGH	LOW	HIGH
7/09Sat	0109/0.6	0740/3.8	1223/2.0	1914/6.4
7/10Sun	0215/0.0	0911/3.9	1328/2.4	2008/6.5
	HIGH	LOW	HIGH	LOW
7/16Sat	0015/6.3	0656/-0.8	1408/5.1	1859/2.5
7/17Sun	0057/6.0	0732/-0.5	1441/5.2	1946/2.4
	LOW	HIGH	LOW	HIGH
7/23Sat	0030/1.5	0646/3.4	1129/2.4	1812/5.5
7/24Sun	0132/1.1	0829/3.5	1230/2.8	1901/5.6
7/30Sat	0554/-0.8	1301/5.0	1744/2.4	2354/6.6
7/31Sun	0631/-0.8	1334/5.3	1832/2.1	

July Weekend Currents

date/day	slack	max	slack	max
7/02Sat	0202	0526/5.3E	0919	1220/4.1F
	1547	1801/2.7E	2106	
7/03Sun		0000/2.9F	0245	0609/5.3E
	0956	1258/4.1F	1625	1845/2.9E
	2153			
7/04Mon		0047/2.9F	0332	0654/5.0E
	1034	1338/4.0F	1704	1931/3.1E
	2247			
7/09Sat	0319	0610/2.6F	0922	1133/2.0E
	1449	1754/2.6F	2055	
7/10Sun		0011/4.3E	0426	0730/3.0F
	1040	1245/1.7E	1559	1858/2.6F
	2152			
7/16Sat	0209	0523/5.1E	0918	1222/4.1F
	1535	1757/2.7E	2115	
7/17Sun		0002/3.0F	0253	0602/4.8E
	0955	1256/3.9F	1611	1835/2.8E
	2200			
7/23Sat	0239	0516/1.7F	0827	1035/1.5E
	1351	1700/1.8F	2004	2313/3.1E
7/24Sun	0345	0638/1.8F	0944	1138/1.2E
	1457	1759/1.7E	2058	
7/30Sat	0106	0424/5.2E	0818	1118/4.1F
	1437	1657/2.9E	2008	2301/3.3F
7/31Sun	0153	0507/5.4E	0855	1153/4.3F
	1512	1739/3.4E	2053	2347/3.4F

THE BOAT YARD AT GRAND MARINA

"Where Service Has Meaning"

Official Sponsor
2011
BAJA
HA-HA

AWLGRIP
US PAINT

**60-TON
TRAVELIFT**



Interlux
yachtpaint.com

FEATURING
TRINIDAD
ANTI-FOULING PAINT BY
PETTIT
marine paint
RATED "SUPERIOR" by
Practical Sailor

IT'S SIMPLE!

Call The Boat Yard at Grand Marina for the Lowest Bottom Prices!

~ COMPARE US WITH THE COMPETITION ~

BOAT LENGTH	THE BOAT YARD AT GRAND MARINA
25'	\$1,012
35'	\$1,459
40'	\$1,740
45'	\$2,148

The Boat Yard at Grand Marina's pricing includes Pettit Trinidad SR paint, which we brush on – *all other yards roll their paint.* The Boat Yard at Grand Marina's only extra costs are zincs and tax on materials.

CALL FOR A RESERVATION

(510) 521-6100 • Fax (510) 521-3684

Located at Grand Marina • 2021 Alaska Packer Place, Alameda

www.boatyardgm.com

Dealers for:

MAX-PROP
AUTOMATIC FEATHERING PROPELLERS

GORI
marine

Webasto
PACKLESS SEALING SYSTEM
SHAFT SEAL

Lectra/san

SIDE-POWER
Thruster systems

facnor
FOULING SYSTEMS

AQUAMARINE
FINE REVERSE OSMOSIS EQUIPMENT

LEARN TO SAIL! Together!

☺ Families ☺ Friends
☺ Groups

For up to four people

Families that sail together - have fun together!
Learning sailing as a group gets everyone
involved and excited about sharing in the sport!

Package Includes

- Basic Keelboat Classes 
- Basic Cruising Classes
- Bay Cruising Workshops
- US SAILING Memberships
- Basic Couple Membership

- Purchased separately -
OVER \$9,000!
ONLY \$4,750!

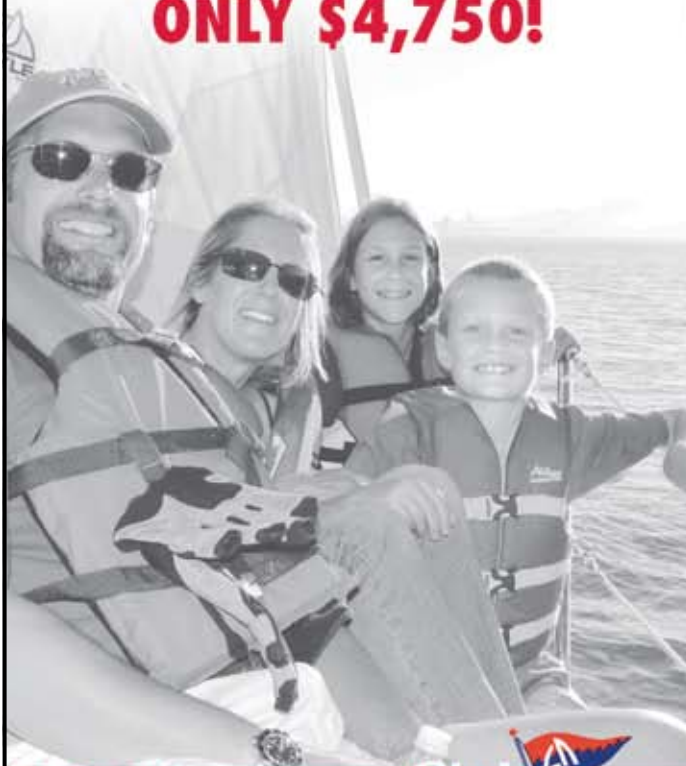

Call Today!

Alameda 800-343-SAIL
Sausalito 800-559-CLUB

**Club
Nautique**
www.clubnautique.net

LETTERS

↑↓ "WILL THERE BE BERTHING IN AUGUST '13?"

As my two-year plan to join the Baja Ha-Ha in '13 continues apace, I have concerns about one part of it. My plan has my boat in San Francisco for the month of August. But with the 34th America's Cup now being a big player on the Bay, am I at all being realistic about finding moorage for that month?



GUILAIN GRENIER

There's no way you want to miss this kind of sailing action, particularly when it's going to be on 72-ft cats.

As nice as it would be to observe the energy on the waterfront, I know the best coverage of on-the-water action

will be via television. Any thoughts/suggestions?

Lani Schroeder
Balance, Endeavour 43
Seattle

Lani — We don't think anybody really knows how many boats will be attracted to San Francisco Bay by the America's Cup. It makes sense to us that a lot of mariners like you, who will be migrating south to the tropics, will see the Cup as a great excuse to stop in San Francisco Bay for the month of August. But will a lot of folks from Southern California with 40- to 50-ft boats make the long slog up the coast to be around the event? We suppose some will, but we don't foresee a mass migration.

We anticipate there will be a real sailing buzz around the Bay during the month of August '13, and that it's going to be great fun. But rather than trying to watch the event from our photoboot, we expect to be a part of the America's Cup via a combination of watching from one of the many shoreside venues or at the Cup Village in San Francisco. The one thing that you can count on is that the event will be presented in the most technologically advanced manner, and there will be an electric atmosphere around the Village. We can't wait to be part of it all.

So if we were in your Top-Siders, we would expect that we'd be able to find a slip in August '13, but in an outer area such as Vallejo or down the Peninsula rather than in the Central Bay. But no worries, as you can liveaboard your boat in those places, and then have an easy commute via public transportation to America's Cup Village or great viewing venues. So yes.

↑↓ HEREWITH AND THEREIN

What do the rules say about an America's Cup boat pitch-poling — as one of the 45-footers did on June 13 — in the Cup Finals?

Bill Nyden
Mountain View



GUILAIN GRENIER

"You can't win if you can't finish."

Beer Can race — you can't win if you can't finish."

It's nice that the new America's Cup rules have been written in language we can all understand rather than in constipated legalese, isn't it?

'Tis a Good Thingge we stopped at Svendsen's
First for a Haul-Out & Bottom Jobbe*... or Historie
might have turned out Quite Differently!

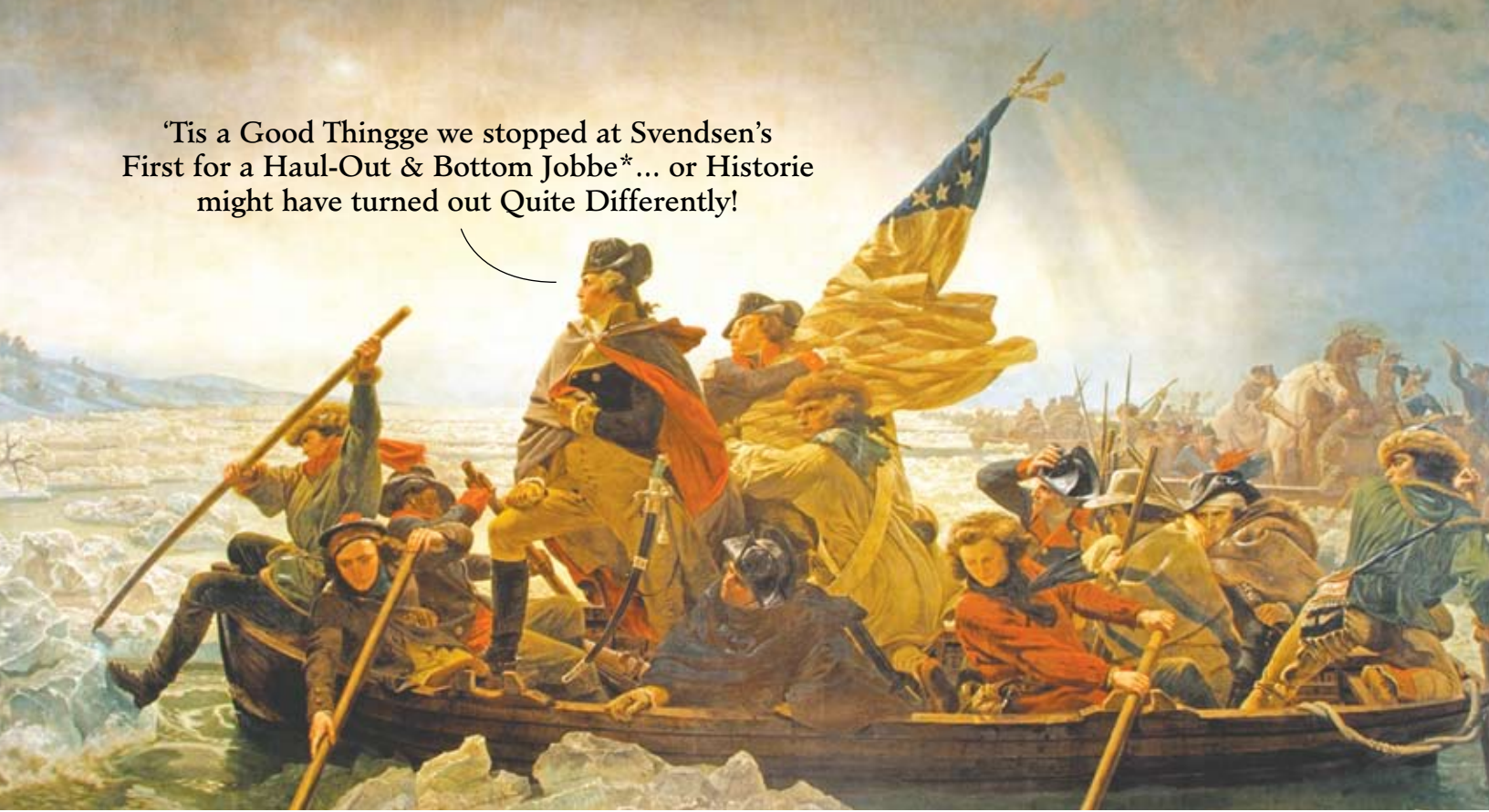

*Note: George Washington was NOT an actual client of Svendsen's.



***Serving You For Over Four Decades,
Svendsen's Is Proud To Be The Bay Area's
Most Trusted & Experienced Boat Yard.***

The highly skilled team at Svendsen's performs all services on site, including:

**Wood & Fiberglass Repairs ★ Standing & Running Rigging ★ Repowers
Bottom & Topside Painting ★ Computerized Engine Diagnosis & Engine Repair
Electrical Repair ★ Custom Metal Fabrication ★ And Much More**

Call to schedule: **510.522.2886** | or schedule online: **svendsens.com**

Svendsen's Boat Works

1851 Clement Avenue, in the Alameda Marina Full Service Boat Yard

Chandlery Open 7 Days: (510)521-8454 or svendsensmarine.com | On-Site Rig Shop & Metal Works

Outboard Engine Owners:

WE UNDERSTAND



When an engine dies, there's no walking home – just costly repairs, lost vacation time, and lost revenues.

Don't find yourself in this boat. Regular maintenance prevents expensive repairs.

We are *your* experts for outboard diagnostics, repair, repower, sales and service.



- Factory-trained and certified techs
- Open six days a week
- New and used engines bought and sold
- One-year warranty on all work performed and used engine sales
- Three-year warranty on all new engines

You will *not* find this knowledge, reputation and network for less.

MARINE OUTBOARD

since 1990

OUTBOARD SALES, SERVICE, REPAIR, PARTS

(415) 332-8020

Nissan
Tohatsu
Johnson
Evinrude



Honda
Mariner
Mercury
Yamaha

35 Libertyship Way • Sausalito, CA 94965

Conveniently located at Libertyship Marina

If we're not maintaining your outboard, you've missed the boat!

LETTERS

↑↓ "PLEASE DON'T HURT ME"

About Russell Coutts' AC45 capsized, which saw him free fall right through the wing sail: I raced Class A cats in the United Kingdom for some time, and they go faster upwind with the lee bow just an inch above the water. It's great — until the tip of the bow gets buried. Then you either sheet off very fast, or you pitchpole, just as the video of Coutts' cat shows.

On another subject, I once effected the rescue of someone trying to commit suicide by drowning himself. In my case, it was someone who jumped off a bridge in Redding into the Sacramento River. I'm a river guide up there, so I made up a loop and dragged the person to the bank, where medical attention was given. You know what a suicidal person says when you offer him help? "Please don't hurt me."

P.S. Can't wait to do the Ha-Ha this fall!

Barry Foster
Tinuwiel, True North 34
Benicia

Readers — We'll have much more reader response later in Letters about the Alameda Fire Department's lack of response to a suicidal man off Crown Beach.

↑↓ A LITTLE SCUTTLEBUTT IS GOOD FOR THE SOUL

Thank you for printing my letter in the June issue regarding berth transfer policies here at San Francisco Marina. Unfortunately, I made a couple of errors.

First, the berth transfer fees at the San Francisco Marina are not based on a percentage of the boat's sale price, but rather on the length of the boat, and can go as high as \$100/ft on larger boats.

Secondly, I could have made my point about berth transfer policy at Fisherman's Wharf without going into quite as much detail as I did. A certain amount of the story I wrote is scuttlebutt. But the indisputable fact is that the boat in question would have been worth far more if its Jefferson Street berth could have been transferred to her new owners.

Hedley Prince
Wharfinger
San Francisco Marina

↑↓ FOLLOW THE GOLDEN RULE

Members of a Northern California Veterans for Peace chapter are rebuilding the *Golden Rule* ketch with intentions



COURTESY GOLDEN RULE

of touring the country with her under sail.

She was the first 'peace boat' — in '58 a group of four Quaker activists sailed her to the Marshall Islands in an attempt to stop the atmospheric testing of nuclear weapons. Members of our group found this ketch, and are currently restoring her in Leroy Zerlang's shipyard in Fairhaven, Humboldt Bay, which is near Eureka.

We're often asked why we're restoring the old ketch and what we're going to do with her. We see her as a genuine relic of the Cold War, one that deserves to be seen and again work in the cause of peace.

She will require at least another year of work, depending on funding. Our goal is to show up in San Francisco Bay during

All we are saying is give the 'Golden Rule' a chance.



Photo Credit: John Navas

THE DOYLE DIFFERENCE

Doyle Sailmakers has the right mix of performance, durability, value and service to earn your business.

We understand that when a sail lasts twice as long, it costs you half as much.

We won't over or under sell you. Our consultants will suggest a fair priced product, precisely tailored to your needs.

Contact your local Doyle loft or visit doylesails.com.



SAN FRANCISCO
510-523-9411



Authorized dealer.

BETTER ENGINEERED SAILS

Synchro Blocks



Lewmar synchro blocks are engineered for speed, efficiency and superior handling. We use a combination of scientifically optimised block geometry, a Free-Spin bearing and self-aligning head to reduce friction and increase efficiency by up to 40% over budget blocks on mainsheet systems. Which means each component is perfectly synchronised with the movement of the rope, providing you with an easier, smoother transfer of power from deck to sail and less wear on your rope.

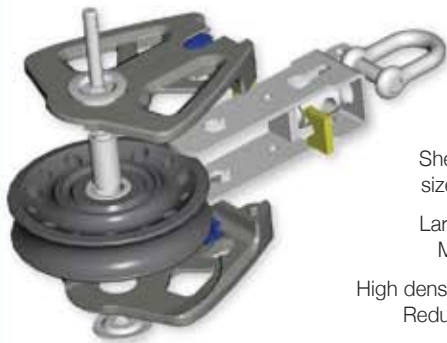

Easy to use shackle post lock - 360° rotation or locked

Lock mechanism - Enables 30° float

Sheave marked with line size & safe working load

Large sheave diameter - Minimizes rope friction

High density free-spin bearing - Reduces axle diameter for superior efficiency

Features

- Stainless steel strap for best strength and longer service life
- Stiff glass fibre reinforced cheeks to prevent lines from wedging
- Innovative design with "tool-free" sliding swivel locking mechanism

Find Lewmar products at:

West Marine Most Locations	KKMI Richmond, CA 510-237-4141	Sea Tek Yachting Wilmington, CA 310-549-1800
	Rigworks San Diego, CA 619-223-3788	Svendsen's Marine Alameda, CA 510-522-2886

LEWMAR
www.lewmar.com

LETTERS

America's Cup festivities in the summer of '13. All the world's media will be there looking for the background stories behind the billionaire yacht races, and we're confident that the *Golden Rule* and Veterans for Peace will be one of those stories.



COURTESY GOLDEN RULE

The NorCal Veterans for Peace are restoring 'Golden Rule' for another peace tour.

We are working to restore *Golden Rule* to first-class condition, because after San Francisco, we're planning to take her on a tour of the United States, visiting as many peace and justice groups as possible via navigable waterways. Our tentative plan is to sail down the West Coast and through the Canal, then up several of the major rivers of the United States, including the Mississippi, to various Veterans for Peace chapters, and to the headquarters in St. Louis.

We will continue to tour many of the rivers and cities damaged by Katrina, around the state of Florida, and up the East Coast of the United States, visiting all of the major cities that are located on the ocean, rivers or bays. Hopefully, we could continue up the Hudson River Valley to Buffalo, and go through those canals to the Great Lakes waterway system to many big Midwestern cities. After that, she would be trucked back to the West Coast, eventually returning to Humboldt County.

We are interested in support, working volunteers and networking. We hope *Latitude* readers will check out our website at www.vfpgoldenruleproject.org.

Fredy Champagne
Coordinator, Veterans for Peace
Golden Rule Project

Fredy — The best of luck with your project. If you get the boat completed, we imagine you'll get more than enough local support to see you around the United States.

↑↓ ARE SPEED LIMITS THE ANSWER?

I'm not so sure a 10-knot speed limit for big ships in California's marine sanctuaries is a well-thought out idea.



COURTESY SKIP ALLAN

When at speed, the turning of a big ship's screw makes a lot of noise. Slow them down and they become much quieter. I suspect a whale would be more likely to get out of the way of a faster, noisier, machine.

Al Reed
Ensueno, Gulf 32 PH
Long Beach

Will whales be any safer if ships travel at slower speeds?

Al — We wish that some kind of solution could be found to prevent contact between ships and whales — and even more so between whales and small boats. We're not sure if a 10-knot speed limit would be a solution, because whales are apparently hit by ships going that slowly, too. And based on our experience of coming north from L.A. to San Francisco on a 960-ft American President Lines container ship, the momentum of the ship was so great that they all but turned off the engine



LET'S BE CLEAR ABOUT IT...

**"Pumping sewage anywhere in
our waterways pollutes the
environment."**

Disease, contamination, low oxygen levels and unsightly water are just a few of the devastating effects of boat sewage illegally dumped anywhere in our waterways and shoreline.

It's simple: You have to plan to properly dispose of human sewage from your boat. Boats with holding tanks must pull in and pump out at shore side pump out stations.

If you have a boat without holding tanks, plan your trip to use shore side restroom facilities.

Don't waste away our waterways! Proper disposal of sewage allows the living things in our waterways to keep on living.

**IF IT'S YOUR BOAT,
IT'S YOUR RESPONSIBILITY.**

California Department of Boating and
Waterways



For more information visit our website
www.BoatResponsibly.com



Scan with your
QR Code Enabled
Smart Phone for
California Vessel
Pumpout Locations



HOGIN SAILS



Locally Made & Handcrafted

**Our sails are USED offshore,
not MADE offshore!**

HOGIN SAILS

- New racing and cruising sails
- Roller furling conversions
- Repair and service
- Boom and canvas covers
- ATN spinnaker/genoa sleeves
- All sails manufactured at our Alameda loft

Call us today to discuss your sail inventory.

510.523.4388

1801-D Clement Avenue, Alameda, CA 94501
sales@hoginsails.com • www.hoginsails.com

LETTERS

down the coast at Davenport, so they weren't coming through the Farallones Sanctuary that quickly anyway.

It seems to us that the ideal solution would be for ships and small boats to be able to emit some kind of warning sounds to whales. We know this has been tried a number of times in the past, but don't believe it's been successful. Maybe more research is needed.

If you see an injured or entangled whale while out sailing, you can report it at (877) SOS-WHALE.

↑↓ SMART PEOPLE, STUPID DECISION

Let's see, you take the James River near Norfolk, Virginia, where the water was 55 degrees, 10 people without lifejackets on a 22-ft sailboat, at night, and a capsized. Criminy, it's a miracle that anyone survived!

Charles Lane
Shamwari, Tayana 37
San Francisco

Charles — The May 13th incident makes us sick, and sadly proves that even very bright people can do some lethally foolish things. All 10 — six men and four women — aboard the small



Ten people on this tiny little vessel was a recipe for disaster.

sailboat were in their 20s, and were either graduate students at local universities doing research at NASA's Langley Research Center or employed by the National Institute of Aerospace. In other words, these were your cream-of-the-crop young folks.

Two of the group, 23-year-old Tyler Lorenzi, originally from Mill Valley and a Northwestern graduate who was an associate research engineer for the National Institute of Aerospace, and Alex Brown, perished from exposure after the capsizing. Five others managed to swim ashore after four hours in the frigid water, and three others were rescued after authorities were alerted to what had happened.

So it was a case of a bunch of smart young folks socializing, as young folks should, but who collectively didn't realize what a dangerous situation they were putting themselves into. Ten people on a 22-ft sailboat? No, no, god no!

See this month's Sightings for the Coast Guard's most recent report on boating accidents and deaths. While the deaths are at a historic low, they are still way too high. Interestingly enough, only a tiny number of boating deaths occur on sailboats.

↑↓ HOW LOW CAN YOU GO?

Latitude's request for feedback on the cost of cruising was a timely topic, as we were just talking about it here in Puerto Escondido, Baja. I've been in Mexico since January of '06, and my total monthly income is under \$2,000. It's taxable, so Uncle Sam takes his cut.

I've tried different ways to budget, but two months ago settled on my current system. The minimum wage in Mexico is a little over 2,000 pesos/month, or about \$175 U.S. So a Mexican couple working full-time makes about \$350 a month. I reasoned that if a Mexican family can live on \$350 U.S. per month, my basic living expenses shouldn't be any more than that.

So once a month, I've been taking 4,000 pesos out of the ATM. If it runs out, well, it runs out. To my surprise, \$350



Berkeley Marine Center

The yard that works for you!

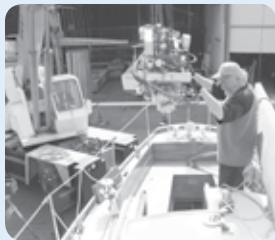

Maintenance,
repairs &
construction
of yachts &
commercial
vessels

- Lift capacity 35 tons
- Sprayed Racing Bottoms
- Full Painting Service
- Fiberglass & Gelcoat Repairs
- Rigging Repairs & Installation
- Electrical Repairs & Installation
- Engine Service & Repowering
- Propeller Installation & Tuning
- Wood Hull Repairs & Caulking
- Teak & Non-Skid Deck Repairs

Committed to the tradition of boating, and a tradition of customer service in everything we do.



Chandlery & Fuel Dock Open 7 Days

Mon – Fri 8 to 5 • Sat & Sun 9 to 5

In Berkeley Marina • 510-843-8195 • www.berkeleymarine.com

SUMMER SAILING CENTER



AND ALL YEAR ROUND

Protected from wind and fog in the summer and surge in the winter.

MARINA VILLAGE OFFERS:

- Full Amenities
- Clean Facilities
- Idyllic Location



Call for a tour or slip reservation

MARINA VILLAGE YACHT HARBOR

Much More than Just a Marina

(510) 521-0905

www.marinavillageharbor.com

LETTERS

has been sufficient for my needs. I've even been able to do normal boat maintenance, such as oil changes and minor repairs, within this budget.

What are my secrets to cruising inexpensively? I rarely



CHUCK LOSNESS

Chuck happily cruises 'Hale Moana' for \$350 per month.

eat out. And I always anchor out because marinas are beyond my budget. I also do all of my own maintenance and repairs. If you have to pay people to fix your boat, your cruising budget is going to zoom — especially if you hire *gringos* with work permits. It would take some of them less

than four hours to go through my monthly budget! The days of inexpensive skilled labor and boat workers seem to be long gone.

The key to my budget has been that no matter what, I don't take more than 4,000 pesos a month from the ATM. It's been my experience that if people have money in their wallet/purse, they will spend it. Myself included.

I was discussing cruising budgets with a friend who has been living on 6,000 pesos/month — about \$500 U.S. — for the last several years. He eats out more often than I do, and he likes his rum. A Canadian friend has a total income of \$1,000 U.S. per month to cover all his expenses, and he manages. All three of us are singlehanders. It seems as though singlehanders spend far less than do couples. The cruising couples I talk to seem to have minimum expenses of \$1,000 to \$1,500 per month.

The bottom line is that you can spend a ton of money cruising in Mexico, but if you're careful, you can also live both comfortably and inexpensively.

To give your readers some background, I was a member of Dana Point YC for 30 years, and did most of my sailing out of there. I found my Gulfstar 37 in Mission Bay in '04, and spent two years there sorting out the boat and making a few modifications, repairs and upgrades. But not too many, because I like things to be simple and easy to use.

By the way, I'm a Sea of Cortez guy. I've been down to mainland Mexico twice, and I don't care for it. Sure, Isla Isabela was great, and I thought Chacala was the best anchorage. But generally speaking, I found that most of the anchorages were too rolly for my liking, and the water visibility wasn't very good. I thought everything south of Chacala was just going downhill, and was making my slog back to the Sea even longer.

I love the Sea of Cortez, and pretty much cruise out of Puerto Escondido, where I have a mooring in the Ellipse. I go down to La Paz for January to March, and spend the summer months in the Bahia de Los Angeles or hauling out in Guaymas. Well, I gotta go — the Sunday potluck starts in an hour and I've got to prepare something to share with the others.

Chuck Losness
Hale Moana, Gulfstar 37
Puerto Escondido, Mexico

Readers — With the U.S. recovery weak, employment opportunities bleak, yet the cost of used boats quite low, an increasing number of readers are thinking this might be the perfect time to go cruising. Naturally, they are curious what it really costs. It differs greatly, of course, depending on how one

THE FINEST SAILS BEGIN WITH THE BEST SAILCLOTH

Our patented woven Vectran® sailcloth performs like the laminates with the durability of Dacron®, especially in roller furling applications. In fact, Vectran® is lighter, lower stretch, and retains its shape over a longer life than any sailcloth we've ever offered to cruising sailors. That's because Hood Vectran® is woven, not laminated to Mylar® film. And you can be sure that each sail we roll out is built by hand, with the same care and craftsmanship that has been the Hood hallmark for 50 years. To discuss your sailcloth needs – whether our state-of-the-art Vectran® or our soft, tight-weave Dacron® – give us a call today.

HOOD Sails & Service

HOOD New Sails

HOOD Sail Repairs

HOOD Furling Conversions

HOOD Pickup & Delivery



SAILMAKERS

Chesapeake

*Jim Fair's Outbound 46
with Hood Vectron
Full Batten Mainsail,
140% Genoa, and
Solent Jib*

PHOTO COURTESY
SWIFTSURE YACHTS
www.OutboundYachts.com

HOOD SAILMAKERS 466 Coloma Street, Sausalito, CA 94965

Call Robin Sodaro (800) 883-7245 (415) 332-4104 Fax (415) 332-0943 hoodsails@aol.com

Visit our website for Special Online Discount Pricing... www.hoodsailmakers.com



LASER SALE



Svendensen's is Pre-Selling a Limited Number of Laser World Boats after the 2011 Worlds Laser Master Championships.

Includes Dolly, New Sail, Blades, & Rigging.

GREAT DEALS - SAVE BIG \$\$\$!

Boats will be available August 13, on a first-come, first-served basis. Deposit required. For further details, call Alex or James at **510.521.8454**.

Sale on Spectra Watermakers



Reliable, quiet, efficient, and easy to use!



20% Off Retail
While Supplies Last

Sale ends 7/31/2011.

May not be combined w/other offers.

1851 Clement Ave.,
Alameda Marina



Phone:
510.521.8454

Shop Online: svendsensmarine.com

LETTERS

wants to cruise, but in this Letters section, an article elsewhere in this issue, and the August issue, cruisers share what they've been cruising on. Enjoy.

↑↓ "I STILL HAVE THE ORIGINAL \$1,000"

In a recent letter, I mentioned that I've sailed around the world, much of the way with my wife, on "a ridiculously low budget." The publisher wrote back to ask me to be more specific.



JULIE TURPIN

Kirk McGeorge has successfully found work wherever he goes.

May I begin with a couple of paragraphs from Sterling Hayden, noted seaman, actor and author, that provided my early inspiration?

"I've always wanted to sail the South Seas, but cannot afford to,' [people say.] What these people cannot afford is to not go! They are enmeshed in the cancerous discipline of 'security'.

And in the worship of security, we fling our lives beneath the wheels of routine — and before we know it, our lives are gone.

"What does a person really need? A few pounds of food each day, heat and shelter, six feet to lie down in — and some form of working activity that will yield a sense of accomplishment. That's all, in our material sense. But we are brainwashed by our economic system, and we end up in a tomb beneath a pyramid of time payments, mortgages, preposterous gadgetry, playthings that divert our attention from the sheer idiocracy of the charade. The years thunder by. The dreams of youth grow dim where they lie caked in dust on the shelves of patience. Before we know it, the tomb is sealed.

"Where, then, lies the answer? In Choice. Which shall it be: bankruptcy in purse, or bankruptcy in life?"

So wrote Hayden. It seems that over the past 17 years of full-time living aboard a boat, I've spent about as much time wandering around under sail as I have in port, working at some form of marine-related enterprise or another. I started in '94, when I purchased Carol Post's Islander 37 motorsailer *Beche de Mer*, which was chained to the dock at the Ala Wai. I re-christened her *Polly Brooks*, and abandoned my sub-sea career by sailing west a year later. When I departed Hawaii, I had \$1,000 left in my wallet, but a job waiting in Saipan. After a 31-day passage across 3,500 miles of ocean, I arrived at a new boat job with a new attitude — and a 'cruising bug' up my ass that kept my gaze fixed on the horizon.

I drove a dinner cruise boat in Saipan for a few months, and then headed south to Guam. Before I managed to clear Customs, I was offered another job on a tour boat! Poking around the Pacific on my boat and getting paid to drive other peoples' boats was heaps of fun! The best part was learning how little it cost to live at anchor, especially when I got fed at work.

Next thing I knew, I was heading south through Papua New Guinea to Australia. I landed in Cairns, and scored a casual job going out to the Great Barrier Reef every day on big, fast ferries, where I attempted to sell helicopter joy flights to the hundreds of tourists. On a good day, I'd fly home with more money than the captain! And with a big bag of prawns for dinner. On a bad day, I'd go scuba diving on one of the seven natural wonders of the world. In my spare time, I'd earn cash by doing canvas repairs and making sailing harnesses with my sewing machine.



**Why Now?
Because These Sails
Come With Free Sheets**

Are you ready for a FREE set of Marlow Sheets???
Contact your favorite sailmaker for details!

Bainbridge and Marlow have partnered on one of the best deals in sailing to harness the power of the wind. Order a sail made from any Bainbridge upwind polyester or multi-purpose downwind sailcloth between now and August 1st, and you'll get Marlow MB12 double-braid sheets for that sail for FREE.

In a testament to durability, Bainbridge has been the world leader in sailcloth for over a century. Marlow is the highest tech rope manufacturer with lines of exceptional quality for every marine application. Get the benefit of both: the highest quality sheets to go with the best quality sailcloth.

Ask your sailmaker for Bainbridge cloth, because durable horsepower is even better when the quality harness is free.

Marlow[®]
distributed by  BAINBRIDGE
INTERNATIONAL

bainbridgeoffers.com

North times six.

When performance counts the choice is clear.
Call your nearest North Sails representative.

Sausalito

New Location!

Sales & Sail Care together - call for details.

415-339-3000

Channel Islands

805-984-8100

Marina Del Rey

310-827-8888

Long Beach

562-795-5488

Costa Mesa - Sail Care

949-645-4660

San Diego

619-224-2424



www.northsails.com

LETTERS

When my Aussie visa expired, I returned to PNG. For six months I had a mate position on a small expedition cruise vessel that took high-end tourists up the rivers and to the outer islands of New Guinea. In addition to pay, I got food and a free berth for *Polly Brooks*.

I returned to Guam for a hard-hat diving job, followed by a stint driving the pilot boat in the commercial port. This



KIRK MCGEORGE

'Arrr Boy' Stuart and mom Cath don't seem to mind Captain Kirk's frugal ways. In fact, the family is thriving.

was when I married a loving lass from Australia. Cath and I slaved and saved in Guam for years, so when we shoved off for the Philippines, Singapore and Thailand in '00, *Polly Brooks* had a new engine, radar, fridge, and electric windlass.

Two years later, we arrived in St. Thomas in the U.S. Virgins, where we worked for the next six years. This is where Cath presented me with a fine son, 'Arrr Boy' Stuart. Needing more room, we sold our Islander Pilothouse — exclusively through a *Latitude Classy Classified* — for a larger and newer S&S-designed Hylas 49. She did, however, need quite a bit of work.

We departed the U.S. Virgins three years ago, and celebrated Stuart's fifth birthday in Trinidad, his sixth in Moorea, and his seventh in Fiji. During this voyage, we dropped the hook in Pago Pago just in time to take a crash course in 'tsunami tsurfing!' Riding out the cyclone season there for eight months, I went to work with the local department of Fish & Wildlife, and Cath worked with the local radio station. Stuart even helped by getting a job as co-host on a kid's Saturday morning cartoon show.

We continued west from American Samoa a year ago, and recently arrived in Australia — three years after quitting our jobs in St. Thomas. Cath has now gone back to work with the same radio network she worked with before joining me, and I'm slowly getting back into the earning groove while simply messing about in boats. 'Arrr Boy' is in school and the Cub Scouts, and standing tall in his new uniforms.

Before I got married, meaning the first five years of this adventure, I simply lived on what I earned while wandering about. Our records show that, after getting married, Cath and I spent a total of \$18,000 — or \$750 per month. Included in this figure were a routine haul-out in Langkawi, a few journeys inland, provisions, fuel, minor upgrades, and so forth. We caught fish, ate well, and always had cold beer in the fridge and a bottle of wine to share.

Everyone knows that the Med is more expensive than Southeast Asia, but it cost far less to cruise than we'd been led to believe.

The cost of maintaining a larger boat is a bit more than that for a smaller one, and the additional cost of feeding, clothing, entertaining, and schooling 'Arrr Boy' has probably doubled our costs. But it seems that whenever we need to stop and rest awhile, some kind of employment naturally presents itself to us.

Being a Navy veteran with minor service-connected disabilities, I'm entitled to health care at any VA hospital or clinic in America. But I'm always careful, so I have rarely used this benefit. As for the cost of health and dental care for my family, when we're cruising abroad, it's a fraction of what it would be in the States. It's true that we haven't gotten paid as much when working in most places we cruise as we would

Blue is Green!

Recycle your old sail and **save green** on a new sail from North!



1. HERE'S HOW...
REGISTER ONLINE* for your free UPS shipping tag, then send your old sail(s) to the North Sails recycling center for delivery no later than Aug. 15, 2011...*the sooner the better!*



Better by Design

Sausalito 415-339-3000

Channel Islands 805-984-8100

Marina Del Rey 310-827-8888

Long Beach 562-795-5488

Costa Mesa - Sail Care 949-645-4660

San Diego 619-224-2424

Onne Van der Wal photo



2. RECEIVE YOUR 20% RECYCLING VOUCHER valid toward the purchase of a new North sail from July 1 - September 3, 2011.



3. PURCHASE YOUR NEW NORTH SAIL
July 1 - September 3, 2011 and elevate your sailing!

PLUS... When we receive your old sail, we'll send you a **FREE** North Tote Bag by **Sea Bags®** made from recycled sailcloth!



*to register, visit northsails.com and click on the "Blue is Green!" icon. You'll help the planet and save on North Sails, too!

*North One-Design sails, Class Sail Development sails, 3DL sails, 3Di sails and North Sails Direct sails are excluded. 50 ft. LOA and smaller. Offer valid on orders placed July 1st through September 3rd, 2011. Customer must take delivery of new sail prior to Nov. 30, 2011 and recycled sail must be received by Aug. 15, 2011.

Blue is Green! program cannot be combined with other offers. Other restrictions may apply.

CELEBRATING 54 YEARS IN BUSINESS



36' BENETEAU 361, 1999
\$89,500



39' AMEL SHARKI CENTER
COCKPIT KETCH, 1980 \$120,000



40' NEWPORTER STAYSAIL
SCHOONER, 1957 \$24,900



41' NEWPORT CUTTER, 1981
\$44,950



42' BENETEAU FIRST 42, 1984
\$82,500



44' SIRENA, 1985
\$109,000



45' C&L EXPLORER CUTTER, 1979
\$43,900



46' PETERSON FORMOSA, 1979
\$85,000



48' C&C PH CUTTER, 1982
\$74,900



50' FERRO CUTTER, 1975
\$28,500

26' GLACIER BAY, 2006 ... \$69,500
26' WELLCRAFT, 1997 19,900
28' BAYLINER, 2002 31,500
38' CHRIS-CRAFT COMMANDER,
1985..... 74,900
40' BLUEWATER, 1980 39,900

41' RINKER VIESTA VEE, 2005
..... 198,500
42' POST SPORTFISHER, 1975
..... 99,800
48' RAMPART, 1969 98,500

NAPA VALLEY MARINA

1200 Milton Road • Napa, CA 94559

(707) 252-8011 • Fax (707) 252-0851
www.napavalleymarina.com

Marina • Boatyard • Chandlery • Brokerage

Dealers for
YANMAR

Interlux
yachtpaint.com

Distributors for *Brownell*
Boat Stands

LETTERS

have back in the States, but we don't need as much money in those places either.

Different countries have different rules about foreigners working in their country. But we've found that if I'm willing to share what I know, and don't take work away from anyone else, people will gladly employ me wherever I go.

There you have it, the way I support my family while maintaining this free lifestyle and keeping a smile on my dial. God only knows where the wind will blow us from here, but my former employer in Guam has offered me the helm of a harbor tug should we decide to head north from here, and the kind family I worked for in St. Thomas seems to want us to return to the Caribbean. So the future looks bright.

By the way, I still have the \$1,000 I set sail from Hawaii with 16 years ago!

Kirk McGeorge
Gallivanter, Hylas 47
U.S.V.I.

↑↓ CHEAPO PENNY-PINCHERS

For almost three years, our Colorado-based family — Jim and Meri, son Tim, daughter Carlyne, rescue hound Bailey Dog and orphaned Mazatlan feline Bad Kitty — have sailed the Sea of Cortez and mainland Mexico. We've enjoyed fabulous experiences and created wonderful memories together.

How much does it *really* cost to cruise? It's hard to say, because everyone is different, every cruising ground is different, and every boat project is different. We know families who cruise for less than we do, and some families who spend much more, but we believe our costs are moderate for a family of four.

If you go to our website at www.expaticus.com and click on the 'Expenses' link, you'll find our '09 numbers and see that we spent a total of \$17,611 — which included a haul-out, a bottom job, a new Engel 12-volt freezer, and three road trips back to the States. Keep in mind that we began calculating our expenses after fully outfitting and provisioning our then-boat, a Cal 35, for our first year of cruising.

In '10, having realized that we'd outgrown our Cal 35, we sold her and purchased a center-cockpit Tartan 41 in Mazatlan. To say she was a 'fixer-upper' is putting it mildly. We

purchased her for a good price, but had to spend five months in a marina repairing her. Therefore our numbers for '10 are a bit whacked. But they do show you what buying a fixer-upper and outfitting her for cruising can cost. Keep in mind that we're cheapo penny-pinchers, 'do-it-yourself-if-you-can' cruisers. We'd rather do our own work instead of paying others, as it allows us to cruise longer.

Anyway our '10 expenses ran \$41,942. This number does not include the sale of *Windfall* or the purchase of *Hotspur*. The cost of an engine rebuild alone was \$10,341, plus another \$8,131 for boat equipment. Had we not incurred the equipment and rebuild costs, our '10 aboard cruising expenses would have been about \$23,000.



COURTESY HOTSPUR

The Faulkner family moved up to 'Hotspur' after outgrowing their Cal 35.

The Faulkner Family
Hotspur, Tartan 41
Mazatlan



YACHT BROKERAGE - SALES & SERVICE WWW.JK3YACHTS.COM

CALL TO LIST AND SELL YOUR BOAT



65' World Cruiser
2006 65' J/65
Maitri \$2,100,000



2000 53' J/160
NovaKane **SOLD**



Med Cup Winner
2006 52' TP52
Stark Raving Mad **SALE PENDING**



Sistership
2001 45' J/145 Carbon
Raincloud \$429,000



2004 43' J/133
Tenacity \$349,000



Cabo Race Winner
2000/09 Refit 41' J/125
Warrior \$389,000



1999 41' J/125
Aunt Jessie \$269,000



New Sails/Bottom
2007 40' J/124
Forgiveness \$295,000



IRC Champion
2008 40' King / Summit 40
Soozal \$579,000



2004 40' J/120 Mad Max II \$200K
1998 40' J/120 Scamp \$169,500
1994 40' J/120 JWorld \$119,000
4 Available



2007 40' Delphia 40GT
Ondine \$183,500

- SAIL.....**
- 1994 43' J/130 \$250K
 - 2002 40' C&C 121 \$230K
 - 1986 38' Baltic38 \$80K
 - 2003 35' J/105 **SOLD**
 - 2007 33' CrossCurrent \$199K
 - 2002 32' J/32 **SOLD**
 - 2010 31' J/95 **SOLD**
 - 2006 30' J/92s \$95K
 - 1993 30' J/92 **SOLD**
 - 2003 28' Corsair F28R Tri \$69K



(2) 2004 35' J/109's
Blue Crush \$192,000
Duster II \$198,900



2001 35' J/105 Javelin \$105,500
'96/'09 refit J/105 #130 \$133,000
2007 J/105 Last Dance \$135,000
2001 J/105 Ondine \$109,500



2008 Sabre Spirit
Dadeline **SALE PENDING**

- POWER.....**
- 2008 44' RENZO Coupe \$549K
 - 2000 43' Grand Banks EB \$329K
 - 2005 38' True North 38 \$340K
 - 1996 31' Albin TE \$84K
 - 2009 30' Raider RIB 9m \$68K

DEALERS FOR THE FOLLOWING BRANDS: CALL 619-224-6200



In Stock - San Diego
SABRE 40 FB w Zeus Drives



In Stock - San Diego
All New BACK COVE 30



In Stock - San Diego
J Boats Hot New J/111



456 Sold - 426 On Order
SABRE 456 Performance Cruiser

SAN DIEGO
Jeff Brown
Jeff@jk3yachts.com
619.709.0697

SAN DIEGO
Kenyon Martin
Kenyon@jk3yachts.com
858.775.5937

NEWPORT BEACH
John Zagorski
John@jk3yachts.com
310.947.2092

HOUSTON
Tom Binig
Tom@jk3yachts.com
713.725.2397

SAN FRANCISCO
Jeff Brown
Jeff@jk3yachts.com
619.709.0697



- NEW
- USED
- REFINANCE



Boat Loans Made Easy®



Let our 30 years of experience go to work for you!

Richard Tressler
866-377-3948 ext. 1047008
www.essexcredit.com

EQUAL CREDIT OPPORTUNITY LENDER

Loan Amounts from \$25,000
Instant Loan Approvals* • 90 Days to First Payment*

*Subject to Loan Program Guidelines and Credit Approval
Reference Code = MAR931

LETTERS

↑↓ FULL OF HOT AIR

After reading the June 1 *Zen Sailing in the Estuary* article in *'Lectronic*, with the bit about Doña de Mallorca's automatic lifevest going off under her jacket, I just had to write.

I left Vallejo in '09 for retirement life aboard here in Puerto Escondido, but prior to heading south, my wife Linda and I used to really enjoy getting into the dink for Vallejo's 4th of



LATITUDE / RICHARD

Doña de Mallorca got a surprise when her auto-inflate PFD auto-inflated.

July festivities and fireworks. If you went on the river, you could practically get right under the fireworks, as they were launched over the Napa River from the city park on the waterfront. It was absolutely great!

One year we and our friend Mike were in the dink for the fireworks when all of a sudden there was a 'psssssss' sound. Oh my heavens, all three of us started looking for the hole we presumed we had somehow just put in our inflatable. When we couldn't find the problem right away, we grabbed our lifevests, assuming that we'd soon be swimming.

But we soon discovered that the 'psssssss' we'd heard was not from some damage to the inflatable, but rather one of our auto-inflate lifevests. Evidently the humidity was a bit much for the poor unit. We reloaded our glasses with vino, and had a wonderful evening watching the rest of the festivities.

By the way, *Latitude* is just 'the bomb', and we in Puerto Escondido simply can't wait each month until someone drives down from the States with a pile of fresh issues. Personally speaking, I've always thought that your magazine's articles have been balanced and well-written. I tip my hat to you and your crew.

Dale Weatherly
Moxie, Ingrid 38
Puerto Escondido, Mexico

Dale — Thanks for the kind words. We're glad you're enjoying retired life in Puerto Escondido, where most of the time life has been more tranquil than here in the States. To make it even better, if you have good internet service, you can download the entire magazine — ads and all — in its full glory directly from our website for free. No need to wait for some generous soul who hasn't gone over their airline baggage limit!

As bad as automatic lifevests going off by mistake might be, there is something worse. We can't remember the circumstances, but a number of years ago one mariner reported that he was in the boat's head with the liferaft — no, we don't know why — and it started to inflate. The person was trapped — and nearly crushed — before the raft could be stabbed into submission.

↑↓ FOCUS ON PLACES WHERE THE SUN DOESN'T SHINE

I'm glad to see that members of the *La Gamelle* Syndicate are enjoying their new-to-them, 31-year-old Olson 30. Having read in the June 1 *'Lectronic* about how the stainless steel bolt that keeps the rudder from falling out of the boat failed, I recommend that, when you go over the rest of the metal on the boat with a magnifying glass as you say you're going to do, you focus on areas where the sun don't shine.

Allow me to explain. Stainless steel has a little known Achilles heel that goes by the name of crevice corrosion cracking. Stainless steel depends on a free flow of air to its surface

10 reasons why boaters choose BERKELEY MARINA

- 1 Direct Access to the Bay**
The best boating experience as soon as you leave the beautiful harbor!
- 2 Free Mobile Pumpout Service**
Berkeley Marina has teamed with BayGreen to offer Free once-a-month mobile pumpout of your holding tank (through Sept. 2011).
- 3 Free WiFi**
The Marina now offers free WiFi access to the internet.
- 4 Sailing Schools & Clubs**
OCSC Sailing, Cal Sailing Club, Cal Adventures – More chances for learning & community!
- 5 Berkeley Yacht Club**
One of the friendliest clubs on the bay – Get involved: racing, cruising, social activities... **Now – membership fee waived!**
- 6 Berkeley Marine Center**
One of the Bay Area's most popular, full-service boat yards!
- 7 Liveaboard Permits Available**
Make Berkeley Marina your home!
- 8 Fuel Dock & Pumpout Stations**
Open 7 days a week.
- 9 Full Amenities**
Berther-only bathrooms, laundry facilities, gated docks...
- 10 Much More!**
Bait shop & deli, launch ramp, hoists, fish cleaning stations, paved parking, free washdowns for trailered boats...

Contact the Marina Office for details



It's a boating community!

AIS Made Easy!

Latest, most cost-effective collision-avoidance solution

AIS (Automatic Identification System) receivers enable AIS-capable chart plotters and navigation software to see other vessels. AIS transponders allow other vessels to see you.

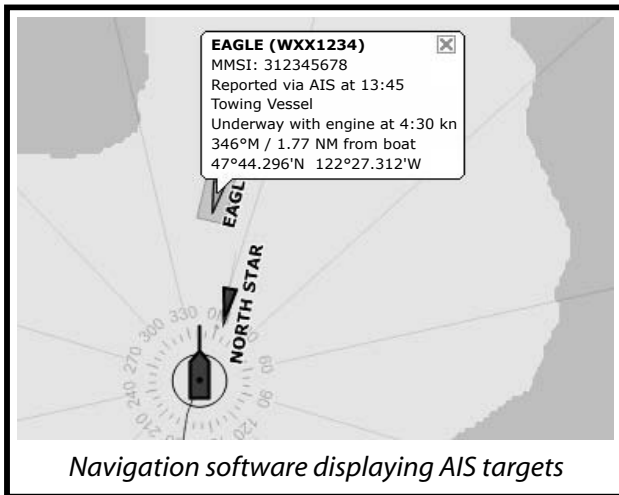

Navigation software displaying AIS targets

Milltech Marine offers complete, low-cost AIS solutions. Visit our web site for information on:

- ✿ AIS Receivers - featuring the Comar AIS-MULTI
- ✿ AIS Transponders - including Class B AIS
- ✿ Navigation Software
- ✿ Antennas, cables and other accessories



Order any product online and use coupon code "LAT38" to get free shipping in the U.S.

For more information contact:



(866) 606-6143
www.MilltechMarine.com

LETTERS

to continuously replenish its oxide surface coating, which is the primary barrier that makes it 'stainless'. Stagnant water, however, contains little or no oxygen, and therefore can preclude the flow of all-important air. This accelerates the depletion of surface oxide coating. If the oxide coating is depleted long enough, corrosion will occur in the crevices between the grain structure of the material.

Any place stagnant water can accumulate for long periods of time while in contact with the stainless is a potential trouble spot. Likely places for this problem are chainplates (where bedding can trap stagnant water), prop shafts inside the stern tube of little-used boats, and fasteners located in wet areas.

The accompanying photos are of an 18-8 stainless



BILL WILLCOX

Flip side of the washer — the side exposed to air looks fine, but the truth is revealed after flipping it over.

washer I use to disabuse my colleagues of their irrational faith in the immortality of stainless steel. The first photo is of the top side. The second is of the flip side. And yes, Virginia, they are flip sides of the same washer! The ugly side trapped water between it

and a fiberglass surface. Some of the worst pitting looks as if 'stainless steel termites' had been at work.

Lack of oxygen can also affect the threads on fasteners.

The good news is that it usually takes a long time for stainless to get this bad. The bad news is that complacency can fool you into thinking everything is good.



LATITUDE / RICHARD

It doesn't take a metallurgist to see that this bolt had corrosion issues.

While *Latitude's* photo of the broken bolt does not confirm that the failure was due to crevice corrosion, I'll bet you'll find at least some of it with your magnifying glass, if you look in the perpetually wet areas of the boat.

While you're at it, if you pull a bolt to check it, at least replace the lock nut with a new one. They are cheap insurance, and the nylon locking part is susceptible to UV degradation.

For the record, I am not a metallurgist.

Have fun with your new toy.

Bill Willcox

Faith, Scandia 34

Currently on SAR assignment in Hong Kong

Bill — Thanks for the great info.

For the record, La Gamelle is not a 'toy', but rather every bit as much of a meditation tool as a sand mandala, a tao totem, nude yoga and all the rest.

⚡ RACERS DON'T ALWAYS MAKE GOOD CRUISERS

My letter is in response to your editorial response to the letter about Abby Sunderland in the May issue.

I raced on the Bay for about eight of the more than 50 years I've been sailing, and believe that the experience taught me things about sailing I might never have learned if I had just cruised. For example, how *really* close you can sail to other boats, buoys, and seawalls without hitting them, how to tweak your rigging for maximum speed, and the sheer joy of eating a handful of brownie crumbs from your foulie pocket while sitting up on the rail. All of that is good experience and made

Ask the Experts...

“I want a hard antifouling paint that lasts, what should I use?”



Stan Susman
Technical
Sales Representative

“Whether you’re into powerboats, sailing or fishing, there’s a product that will fit all these types of boats* and deliver the performance you expect !

Interlux Ultra™ is the premium, durable antifouling paint that offers more than long term performance:

- Ultra has a durable, hard finish with superior hide. A thicker paint, it gives you significant film thickness in two coats, which gives you the longevity in performance and prevention of premature wear through
- Long track record in high to medium fouling areas, it’s designed to deter barnacles, weed and other types of fouling – in all waters!
- Ultra has excellent color stability – even at the waterline!
- Formulated with Biolux® Technology to fight slime
- Ultra has reduced emissions as it’s formulated using less solvent

Whenever and wherever you decide to haul your boat, ask your boatyard for Interlux Ultra, the best performance at a very competitive price!”

 **Interlux®**

Our World is Water



** Not suitable for aluminum hulls. For boats frequently in and out of water, we recommend Micron® Technology antifouling.*

Interlux®, the AkzoNobel logo and other products mentioned are registered trademarks of, or licensed to, AkzoNobel. © Akzo Nobel N.V. 2011. Use antifouling safely. Always read the product label.



AkzoNobel

Find more answers at yachtpaint.com



BLUE WATER YACHT INSURANCE

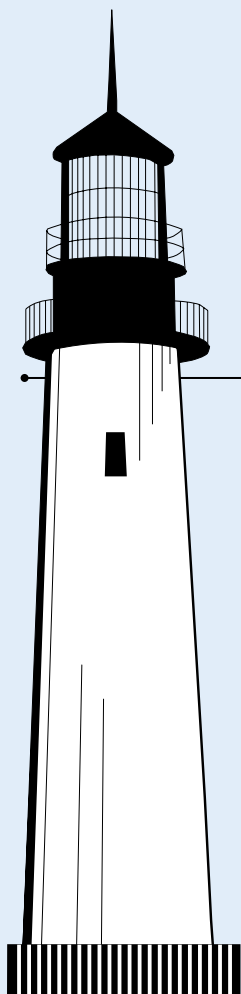

Blue Water Yacht Insurance covers more active cruising boats than any other marine insurance agency in the Western Hemisphere, and is the leading innovator of insurance products for the offshore sailor.

Our Insurance Programs Provide:

- Crew of two anywhere
- Worldwide Navigation
- Hawaii
- Caribbean
- South Pacific
- Mexico
- Charter Boats
- Multihulls
- Liveaboards
- Racing Boats

Quality Rated Insurance Companies

Boats aged 1 to 40 years • "Agreed Value"
"All Risks" • "New for Old" replacement partial losses
Hulls valued \$50,000 to \$2,500,000

Worldwide Health Insurance

International and USA health insurance plans at affordable prices.



BLUE WATER
INSURANCE

Call Toll Free
(866) 463-0167
Fax: (866) 795-3707
sales@bluewaterinsurance.com

Quote requests
Visit our website

www.bluewaterinsurance.com

LETTERS

me a much better sailor.

I think Abby Sunderland's adventure was ill-advised to say the least, but whether or not she or her brother Zac, who successfully circumnavigated, could win a race in the Estuary against peers — as *Latitude* suggested would be interesting — doesn't necessarily correlate to their long distance, bluewater capability. Most racers I know hire someone to fix things that break, and only have to worry about weather and sea conditions for the next six to eight hours. Bluewater cruisers face a different set of challenges.

No offense to the many fine skippers I raced with, but if they invited me to sail around the world with them, I'd have a long list of qualifying questions to ask before signing on.

Marcy Zimmerman
Sandman Too, Catalina 30
Pt. Richmond

Marcy — While a racing background doesn't necessarily correlate with being a successful cruiser, most racers who want to cruise — and lots of them aren't interested — do very well at it. If we had to choose whether to go with someone who had a racing background or no racing background, all other things being equal, we'd go with the former.

We don't want to get into the whole Sunderland thing again, but neither Zac nor Abby was the least bit self-sufficient. They benefitted tremendously from extensive support teams prior to the start of and during stops in their circumnavigation attempts. And unlike Robin Lee Graham, for instance, who was out of communication with shore while going around, the Sunderlands were in frequent phone contact with shore for emotional support, weather forecasting and mechanical assistance.

↑↓ WE ALL GO WHERE THE WIND BLOWS

You need to read Laura Dekker's epistle of June 11, which is all about her checking-in woes. I would accuse her of plagiarism for writing "we go where the wind blows" — except that she's way too young, naïve and innocent to know that she is

somehow repeating your mantra. By the way, she writes as if she is much older, and reports her sailing adventures as though she were an adult rather than a teenager.

Byron Corley
Sabrina, Rawson 30
Fremont



COURTESY GUPPY

Laura Dekker is currently exploring the South Pacific.

Byron — As is well known, we're not in favor of age-based sailing records, and therefore believe that 15-year-old Ms. Dekker's attempt to become the youngest person to solo circumnavigate is a stunt that, even if successful, won't prove much. Except, of course, that the lure of fame and fortune is as strong for kids as it is for adults.

As for her writing "we go where the wind blows" in her Day 295 report from Tahiti, we're not bothered in the least. After all, it's a common enough thought, and she clearly had no intention of trying to copy us or trade on our reputation.

As for her reports, someone on her team is almost certainly editing them for public consumption. This doesn't get our knickers in a twist either.

↑↓ A BOONDOGGLE BONANZA

San Francisco approving a plan for 19,000 new residents

HAPPENING HOMEPORT



Calling all Catalina Owners:
Join the Catalina Rendezvous
July 15-17
Details at <http://raft.c380.org>



**Others may scratch the surface,
we go to great depths for you.**
Call for deep draft berthing.

**Deep draft, convenient-to-the-course berthing
for the most discriminating racers and cruisers.**

Visit our website

Marina Bay Yacht Harbor

www.MarinaBayYachtHarbor.com

(510) 236-1013



LETTERS

on Treasure Island — but with no public facilities — is just another San Francisco boondoggle that is all politics and no common sense. It's just like the multibillion dollar bridge project. The island should be developed for public use and facilities, as was the original intent.

Robert Lockwood
Celebration, Gulfstar 50
Alameda

Robert — As we've written before, we don't have strong feelings either way on the Treasure Island project. We think its success or failure is going to be completely dependent on the details. Unfortunately, local government has a dismal record overseeing major projects on behalf of taxpayers.

↑↓ WHERE DID THE MONEY GO?

Latitude's report on the Alameda Fire Department's refusal to help a suicidal man standing in the water off Crown Beach was largely correct, but it should be noted that Interim Chief Michael D'Orazi had only been on the job one week. There was another interim chief between him and David Kapler, the latter being the chief who was dismissed after he was observed filling the tank of his BMW convertible from the fire department's tanks.

One of the bigger pieces of B.S in this story is the fire department's line that 'we're not trained for water rescue'. The fire department was trained and continuously re-certified for water rescue up to '09. They stopped re-certifying that year because of a budget shortage. The bottom line is that many of the men on-scene had received extensive training, but just didn't have the current piece of paper. It's like saying that if your driver's license expires, you don't know how to drive a car.

The big question is how so many qualified public safety officers can stand and watch someone die without one of them deciding that it's worth getting in a little trouble to do the right thing. Unfortunately, there's really no answer for that one.

John Hansen
Alameda

John — Matthias Gagni reported in the Contra Costa Times that the fire department had been allocated the money to continue rescue training, but for some reason the department hadn't spent the money on the training and certification.

↑↓ DISGUSTING AND IMMORAL

A man died in Alameda because public union rules were stronger than the testosterone of our public servants. Disgusting and immoral.

Mark Leonard
Corte Madera

Mark — According to officials in Alameda, firefighters wading into the water to try to help the man would have been in violation of Occupational Safety and Health Administration standards. Ironically, "water rescues" is specifically listed as one of a firefighter's job responsibilities. Not that this was even a real 'water rescue' situation.

↑↓ A 'LOW RISK, HIGH REWARD' SITUATION

It sure does look bad for the first responders, but as a former lifeguard, I want to say that it wasn't a normal water rescue, but rather a successful suicide attempt. Most firefighters are not trained for water rescue, but rather to fight fires and untangle wrecked cars. Many fire departments have specially trained water rescue teams, but these are not suicide preven-



Sailrite

sunbrella® Marine Grade Fabric

The premier fabric choice for outdoor marine tops and covers. It's UV, water, and mildew resistant with the strength and clean ability you expect from the world's leading performance fabric.

First quality Sunbrella®. Always in stock.

Free Catalog | 800.348.2769 | www.sailrite.com

How You Gybe Is Your Business



How you fix your boat is our business

Accidents do happen - even to the most skillful sailors. And when repairs are needed, you need a boatyard that gets your boat back, like new again, into the water, ready for your next adventure.

The sailor's boatyard, Bay Marine Boatworks is a full-service boatyard in the full sense of the word. We offer a complete range of services at prices lower than the competition, and provide an accurate estimate up front. From bottom painting to complex fiberglass repair work, you'll find we can handle all your sailboat maintenance and repair needs. Our mission is to guarantee absolute satisfaction to every customer. Which is why we are good at finding the solution you need, instead of what the boatyard needs.



310 W. Cutting Blvd.
Pt. Richmond, Ca
(510) 237-0140

www.baymarineboatworks.com

So bring your boat, and your pride, to Bay Marine Boatworks, and we'll repair both!

BAY MARINE
BOATWORKS Inc.
The Sailor's Boatyard

- Fiberglass, Gelcoat & Painting
- Mast Stepping Rigging Work Mast Tuning
- Thru-hulls and Valves
- Drivelines and Engine Service
- Woodwork
- Welding & Metal Fabrication
- Electrical & Plumbing

NORTHERN LIGHTS
VOLVO PENTA



Summer Sailing Headquarters!

Visit westmarine.com to shop our **New One Design** offerings



Mobile Rigging Service Available

Your Complete Rigging Source!
Installation • Lifelines • Running Rigging
Standing Rigging • Dock & Anchor Lines



Contact us for all of your Rigging Needs!
888-447-RIGG

or visit our Onsite Rigging Locations in:
Alameda, CA 730 Buena Vista Ave. (510) 521-4865
San Diego, CA 1250 Rosecrans St. (619) 255-8844
Seattle, WA 1275 Westlake Ave. N (206) 926-0361

westmarine.com/rigging

LETTERS

tion teams. Suicide and attempted suicide are crimes, but if someone is in the water, what are first responders to do?

One of the first things I was taught in lifeguard training was not to risk your own life for a rescue, especially in extremely hazardous conditions.

David Mulmat
Flying Shadow, Beneteau First 47.7
San Diego

David — Thank god you're no longer a lifeguard. Alameda firefighters were certified in water rescues as recently as '09. Are they such morons that they've already forgotten their training? And since the money for recertification had been allocated a long time ago, the Alameda Fire Department needs to explain why they weren't recertified.

"What are they to do?" Just because the firefighters weren't trained in attempted suicide response doesn't mean they have to behave like helpless idiots. Three of the firefighters could have slowly walked out to within 15 feet of the despondent man and assured him that he had friends and relatives who loved him, and that he still had a lot to live for. A couple of weeks later a suicidal man was talked down from the Bay Bridge in this manner.

"Extremely hazardous conditions?" What!? Here's an excerpt from Daniel Lisker's contribution to the Contra Costa Times Readers' Forum titled: *Man Died from Alameda Firefighter Negligence and Incompetence*:

"It is unfortunate and disgusting that a depressed man lost his life in the water off Crown Beach on Memorial Day because of the lack of appropriate response by the Alameda Fire Department. Situations fall into four classifications according to risk to personnel and probable outcome of the situation: Low risk, low reward; low risk, high reward; high risk, low reward; and high risk, high reward. From the video of this sad scenario that I saw, this man was about 100-150 yards offshore in about 4-5 feet of water. This was not a water rescue; this was a case of wading out to the man, communicating with him, and walking him back to the beach.

"For any incident commander, this situation fell into the category of low risk, high reward. End of story. This man died because of the negligence and incompetence of the Alameda Fire Department."

WHERE WAS THE COAST GUARD?

What was the Coast Guard's role in the incident? I understand that they had a boat on scene, but that the water wasn't deep enough for them to get to the victim. If that was the case, why didn't they request a helicopter?

About 20 years ago I found myself in a similar situation when, sitting in the office of the marina I managed, I noticed a woman floating in the water. I told my secretary to call 9-1-1 as I rushed to the dock and, without any hesitation, jumped into the water and saved the woman. I learned later that she was despondent over the loss of her husband and was attempting suicide.

Jim Haussener
Vallejo

Jim — The Coast Guard did get a boat to the scene, but the subject was standing in shallow water. A Coast Guard helicopter was called, but having been on another mission, it arrived too late.

But no boat or helicopter was needed, just an Alameda public safety employee with a big enough sense of humanity and big enough balls to wade into the chest deep water. Wade into the

Management
Consulting
Development

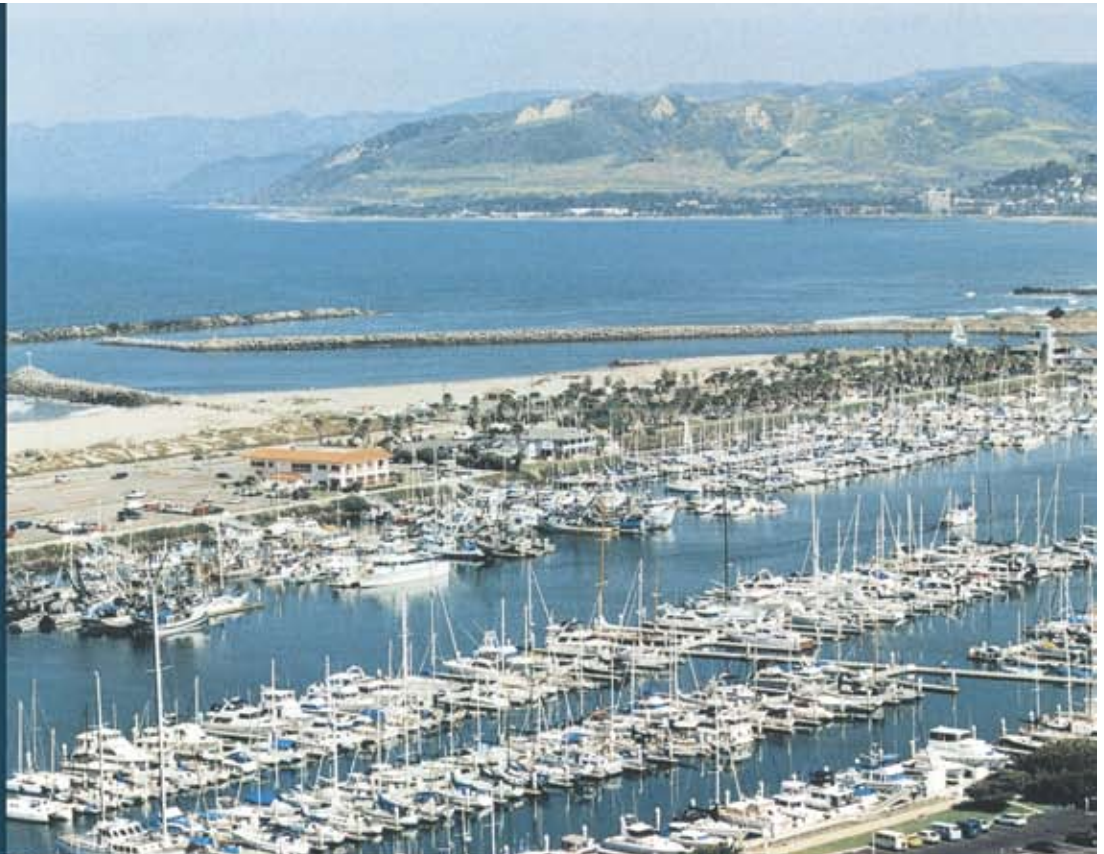

Almar Marinas

Join one Almar Marina and you have reciprocal privileges at any of Almar's 17 locations from San Francisco to San Diego and out to Hawaii. Programs included in your slips fees: *Boat Handling Classes *Navigation Courses *Electrical Courses *Anchor Outs *Seminars on Local Destinations.



EST. 1973

almar.com

San Diego * Cabrillo Isle Marina * Marina del Rey * Marina del Rey Marina * Channel Islands Harbor * Bahia Marina * Anacapa Isle Marina * Peninsula Marina * Westport Marina * Ventura Harbor * Ventura Isle Marina * San Francisco Bay * Treasure Isle Marina * Jack London Square * Jack London Square Marina * Oakland * NEast Basin Marina * NWest Basin Marina * Embarcadero Marina * Union Point Marina * Alameda * Ballena Isle Marina * Martinez * Martinez Marina * CA Delta * RiverPoint Landing * Honolulu * Kewalo Basin Harbor * Oahu * Iroquois Marina *

SCHOONMAKER POINT MARINA

• IN SAUSALITO •



**160-Berth Marina in one of the
most beautiful spots on the Bay**



- Visitor berths • Guest moorage up to 220 ft.
- 35-ft to 75-ft slips • Pumpouts • Marine services
- Dry Storage Available • Three-ton hoist
- Restaurant • Beach • Rowing • Kayaking

Sausalito's Finest Marina

85 LIBERTY SHIP WAY, #205
SAUSALITO, CA 94965

415-331-5550

FAX 415-331-8523

www.schoonmakermarina.com

LETTERS

chest deep water like the young woman who ultimately had to recover the body for the firefighters. Wade into chest deep water as a dozen people did a few weeks later to protest the pathetic response on the part of the Alameda Fire Department.

↑↓ I KNOW YOU ARE BUT WHAT AM I?

You're an asshole.

Dale Speroni Riva
Siren 17
Fairhaven, WA

Dale — And you're eloquent in expressing a point of view.

↑↓ YOUR TAX DOLLARS NOT AT WORK

The people of Alameda are paying a lot of money for heroes. They got cowards.

Cary Otis
Swallow, Nor'Sea 27
Petaluma

↑↓ OBSCENE SALARIES AND PENSIONS

According to the *Alameda News*, the incompetent sociopaths in the Alameda Police and Fire Departments twice declined to request Alameda County Fire Department rescue boats that stood ready in San Leandro. Even after being advised the boats were available! The *Alameda News* also reported that the Alameda Fire Department has two boats of their own that are mothballed, while firefighters pull down obscene salaries and pensions.

Timothy B. McCormick
Walnut Creek

Timothy — Are you suggesting that if firefighters contributed a little bit more of their generous salaries to their own pensions, Alameda could have an entire fleet of first-class rescue boats? If so, you're probably right. In the year '08, the last year for which we could find records, 27 members of the Alameda Fire Department received over \$200,000 in compensation, and 15 of them weren't even brass.

↑↓ PUSSIES!

Horrible, just horrible. Fire them. Jail them. Everyone I've talked to here in Alameda is ashamed of the Fire and Police Departments, their personnel, and their combined lack of response. Any one of them would have been a hero to 'break the rule'. Pussies!

Daniel G. Hayes
Alameda

↑↓ GO TO JAIL, DO NOT PASS GO

The 'non responders' should be arrested and tried. You may recall the Sydney Hobart Yacht Race of '98, where sailors lost their lives in the ferocious weather conditions. One civilian skipper ignored calls for help because he felt the weather conditions were too severe. If you want to discuss the matter with him, he's easy to find, because he's still in jail for not trying to help others. Jail is where these brave Alameda first responders belong.

Perry Mullinix
January's Child II, Hunter 35
San Francisco

↑↓ EUREKA DOESN'T KICK IT ALAMEDA FD-STYLE

I'm disgusted to my core, as that was the worst example of the human condition on our soil that I've ever read. As a soci-

Yacht owners trust **PACIFIC CREST CANVAS** for the best in design, service and quality.

*Still the Highest Quality
Products at the Best Prices*

• **Offshore Dodger™**

Welded aft handrail
Bolt-on side handrails
Lexan windshields

• **Baja Awning™**

Lightweight and waterproof
Durable and easy to launch
Multiple side screen configurations

• **Coastal Dodger™**

Affordable designs
Same high quality materials
Same superior workmanship

• **Cruiser's Awning™**

Easy setup off your dodger
Flies with no bulky frame
Comes with shade screens



Jessica and Jim enjoying the start of the Cruising Lifestyle.

Open Monday-Friday 8:00-4:00
Saturday by appointment
(510) 521-1938



2021 Alaska Packer Place
Alameda, CA 94501
Grand Marina

www.pacificcrestcanvas.com

SAUSALITO

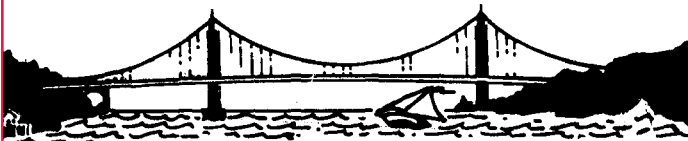

LIST MARINE INC.

- Full service engine shop
- We service all makes
- Dockside facilities
- Mobile service trucks

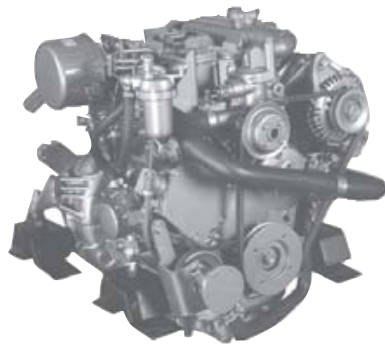

P.O. BOX 2008 / 69 LIBERTY SHIP WAY • SAUSALITO, CA 94966
Adjacent to Schoonmaker Pt. Marina

415•332•5478

www.listmarine.com

"LOVED YOUR WORK"

— Greg Frame, after cruising thousands of trouble-free miles through the South Pacific in his Norseman 447.

**30 years of experience adds up to reliability you can trust.
Call us for your next project!**

HANSEN RIGGING

510.521.7027

2307 Blanding Ave., Suite G, Alameda, CA 94501

www.hansenrigging.com





MARINA RIVIERA NAYARIT
AT LA CRUZ

**MORE THAN 340 VESSEL
CAPACITY (30-400 Ft)**

FUEL STATION - DRY DOCK - 150
TON TRAVELIFT - YACHT CLUB

El sueño hecho marina...



*Come and enjoy our beautiful marina with first class
services surrounded by spectacular views
of the Banderas Bay.*



*"one of the best experiences, no hesitation in
letting others know what a great place you have -
thanks to all who made our stay so enjoyable"*

Andrew Linney, www.nokaoi2.info



LAT 20°45'N / LON. 105°24'W

Marina Riviera Nayarit, Marlin 39-A
La Cruz de Huanacastle, Nayarit, MX 63734
harbormaster@marinarivieranayarit.com
Tel. (329) 295.5526 • Cel (322) 205.7467
www.marinarivieranayarit.com

LETTERS

ety, we've lost all reason. I totally agree that the chief should be charged with manslaughter and the rest of the public safety people on the scene be fired. We have to turn the tide on our collective gross lack of common sense and decency.

Adrian Morgan
Motu, Cross 40
Sebastopol

Adrian — We think everyone is so angry because the public safety folks in Alameda behaved in such an aberrant way. On June 15, a despondent man jumped off the Samoa Bridge between Eureka and Woodley Island. The Eureka Fire Department was on the scene within five minutes, and noticed the man having trouble staying afloat 50 yards from shore. Instead of watching the man drown Alameda Fire Department-style, firefighter Jason Campillo, wearing a dry suit, jumped into the water and brought the man back to shore. The man was rushed to the hospital and survived.

↑↓ A \$200 CAR WASH

As an avid sailor for 63 years and a resident of Alameda for 40 years, I think the non-action by these 'heroes' on Memorial Day was unconscionable. We know that laws and policies are broken repeatedly in the name of saving a buck, but in this case nobody would break a policy to save a life. It was left to a young female civilian to do what the rest of them should have done.

The list of compensation for the entire Alameda Fire Department is public record. If you look it up, you'll see the average fireman with a high school education and five or so years in the department receives a total compensation of about \$225,000 a year — not counting retirement, starting at age 50, at nearly full salary.

By the way, about two weeks ago I was driving by the Grand Street fire station in Alameda, and observed a firefighter washing his late model Porsche — which was parked in front of the fire trucks. Were we citizens of Alameda paying him \$200 an hour to wash his car?

John Selbach
Alameda

John — We presume your point is that the guy washing the Porsche while on duty could have more wisely used taxpayer's money by brushing up on his wading skills. If so, we agree with you.

As for Alameda firefighter compensation, a low-end firefighter makes about \$130,000 to \$140,000 a year in total compensation. If a regular firefighter wants to work the overtime game, he/she can knock down \$239,000 — as was proven in '06 by Louis Donati, Jr. Of course, if you want to factor in the approximately \$135,000-a-year pension they are likely to collect if they retire at age 50, in that sense even basic firefighters can be viewed as making a quarter of a mil a year.

We received many more angry and disgusted letters on this subject, but have nowhere near enough room to run them all.

↑↓ LEAKING SAILDRIVE SEALS ARE NO BIGGIE

I read the paragraph in the June *Changes* about one cat owner's saildrive showing no signs of rust after the lower seals had been leaking, and letting water into the transmission oil, for six years. He had, however, been changing the oil every three months or so.

After 12 years and about 2,500 hours on the saildrive on our boat, I had to replace the lower seals due to water leaking into the transmission. While I have the transmission oil



No wind?

No problem.

The 4-Stroke SailPro with 25" Shaft,
Designed to co-exist with Sailors.



Sailing just got better with Tohatsu's newly redesigned 6hp SailPro featuring:

- Front mounted shift lever, an industry first in its class
- High thrust sail propeller
- 5 amp/12 volt charging system
- Longer tiller handle (110mm extension from previous model)
- EPA & CARB emission approved

For more information & to see the new SailPro, visit the Tohatsu dealer nearest you today.



TOHATSU
Delivering Reliability.

www.tohatsu.com 214-420-6440
©2011 by Tohatsu America Corp.



**VALLEJO
MARINA**



Gateway to the Bay & Delta

Best Slip Prices in the Area!

- Full Service Boat Yard
50 Tons
- 23' x 9' Storage Units Available
- Live-aboard Slips
- Multihull Slips



(707) 648-4370 • Fax (707) 648-4660

42 Harbor Way • Vallejo, CA 94590

www.ci.vallejo.ca.us marina@ci.vallejo.ca.us



McGinnis Insurance

Since 1972

Agreed Value Yacht & Boat Policies

**Offshore, Coastal, Inland,
Liveaboards & Floating Homes**

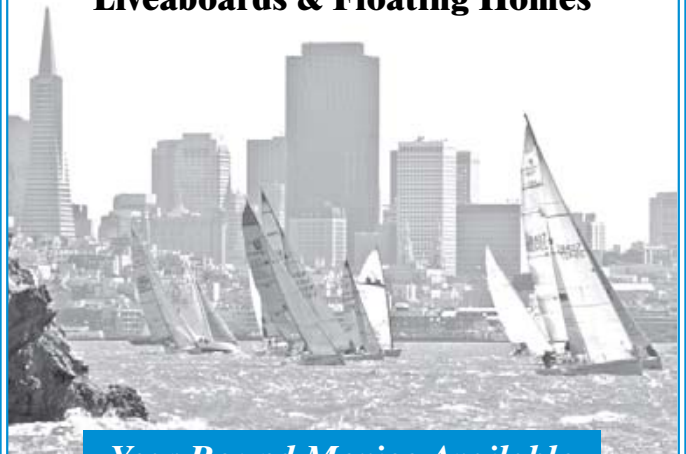

Year Round Mexico Available

Call us at: **800-486-4008**

meginnsins@aol.com ☞ License #0570469



South Beach Harbor is a great way to experience San Francisco. Boats of all sizes are welcome in our protected deepwater harbor. Bring your boat to South Beach and enjoy all the attractions of the city.



- Two guest docks for boats up to 125'**
- 20 guest berths up to 50'**
- Casual and fine dining nearby**
- Adjacent to AT&T Park**
- Easy access to transportation**
- 24 hour security**
- Free pump-out stations**



For Reservations:
 415.495.4911 (x1111)
 fax: 415.512.1351
 sb.harbor@sfgov.org
 www.southbeachharbor.com

LETTERS

changed during each annual haulout, I didn't know the seals had been leaking until the haulout, so I had no idea how long it had been going on. But there was no sign of rust.

By the way, having had both stand-alone transmissions, and currently a saildrive, I think they are of equal quality. My saildrive is a Volvo Penta.

Myron Eisenzimmer
 Mykonos, Swan 44
 San Anselmo

Myron — That's great news because we always assumed that if even a little bit of water had gotten into our saildrive transmission oil we'd have to pretty quickly get our big cat to one of the few places she could be hauled out in order to change the seals. Or as Scott Stolnitz did, find a place with a big enough tidal range to ground the cat and replace the seal.

Based on our experience, we prefer regular transmissions to saildrives. In the 13.5 years we've had Profligate, we've gone through two sets of Yanmar saildrives in her 7,500 engine hours, and on the most recent set, have twice had to replace the cone clutch, which seems to be a relatively common problem on boats with saildrives. On the other hand, we've got 7,500 hours on our charter cat 'ti Profligate's regular transmissions, and to our knowledge they haven't needed any repair. And lord only knows what abuse inexperienced charter skippers have inflicted on them.

↑↓ RATE OF EXCHANGE

We enjoyed the May article about the three foreign exchange students from Germany who were brought together with Bay Area sailing families through the kindness of *Latitude's* publishing information about the Inter-Ed program administered by Cheryl Williams of Clovis.



COURTESY CLARSA

Bella Ries looks comfortable at the helm of 'Clarsa'.

There was actually a fourth sailing student, Isabella Ries, in the program. Known by all as Bella, and from Flintbek near Kiel where she sails with her dad on the Baltic Sea during their short summers, she was placed with our family.

While we only got Bella out on the water once during her stay — that being on May 21, when we sailed out of Benicia on our Venture 23 *Clarsa* — we kept her busy with camping trips, a spring break visit to Disneyland, a flight over the Bay, and a weekend at Tahoe, where we nearly got snowed in during the middle of May.



KATHY CROWLEY

Don't thank us, Bill. You and Kathy get all the credit.

Bella consistently exhibited a maturity level beyond her 16 years, was very reliable in keeping to her arrangements, was helpful around the home, and did exceptionally well at Napa High School. As was the case with her mates in the Inter-Ed program, she was an easy keeper.

Our experience with Bella added a lot of joy to our "empty-nester" home, and we highly recommend the program to other Bay Area sailing families. We and Bella are extremely grateful

35-55' slips available

Own a Dock on San Francisco Bay Perfect Location - Great Investment!

EMERY COVE
YACHT HARBOR

Come secure a front row seat for the cup races in 2012/13.

BUY A SLIP - Save money and earn equity! Save on your annual rental cost. Enjoy tax savings as a slip owner. Enjoy low maintenance as an investment property. Emery Cove Yacht Harbor is the only marina on the Bay with FEE SIMPLE (not a grounds lease) dockminium ownership. Listings start at \$32,000.

RENT A SLIP - 35-60' slips, rates from \$9 to \$10.

MARINA GUARD® - Ground fault monitoring. **WIRELESS INTERNET** - Free

Emeryville Yacht Club,
Mathiesen Marine,
Michael Wiest Yacht Sales
& SailTime
on premises



CALL FOR A MARKETING PACKAGE • 510-428-0505
3300 Powell Street, Emeryville, CA 94608 • www.emerycove.com • Email: info@emerycove.com

AQUAMARINE

Watermakers Since 1987

SPARKLING FRESH WATER, POWER, AND REFRIGERATION FROM THE SEVEN SEAS



AquaGen combines the quality, simplicity & reliability of AquaMarine, Inc. watermakers with the durability of the Kubota 150 amp 12V diesel generators. This compact low fuel consuming AquaGen is a powerhouse, capable of producing up to 150 amps, and 8 up to 62 GPH of fresh potable water from any water source. Make fresh water, refrigeration, and also charge your batteries all at the same time! A hydraulic pump may also be added to run your dive compressor, windless, bow thruster, or emergency bilge pump. Ideal for longterm cruisers or weekend wanderers. We custom engineer our systems to fit any size vessel or cabin site. Electric, Hydraulic, or Belt Driven Modular Kits are also available. Visit our Website for more information.

QUALITY AT AFFORDABLE PRICES.
LIFETIME WARRANTY ON PUMP HEAD AND PRESSURE VESSELS.
AquaMarine, Inc., 58 Fawn Lane (P.O. Box 55) Deer Harbor, WA 98243 USA
(800) or (360) 376-3091 Fax (360) 376-3243

www.aquamarineinc.net

Now in our 43rd year!



Dear Travis and Colin:
We've had a wonderful summer of sailing...and have received numerous compliments on the sails, Mack-Packs, and the improved performance of the boat. We've done a bit of racing and, after a classic boat race, one competitor (a sailmaker in Seattle) said he was really impressed with our sails... (happy Port Townsend customer)

**All Mack Sails are Built to Last
...and designed to be Fast**



Every Mack Sail is Made in Our Stuart, Fla. Sail Loft



Colin Mack and Travis Blain
Partners in Mack Sails

High Quality and Great Customer Service
Have Certainly Made Mack Sails...

the Biggest Small Loft in the USA

MACK SAILS
3129 SE DOMINICA TERR. STUART, FL 34997
(772) 283-2306 FAX (772) 283-2433
(800) 428-1384 (772) 283-2306
INFO@MACKSAILS.COM WWW.MACKSAILS.COM

Also See Us for Rigging, Hardware and Electronics --- We Ship Everywhere

Gori propeller

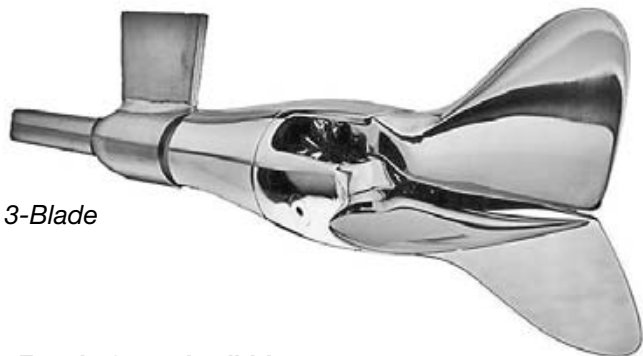

3-Blade

- For shafts and saildrives
- Both 2 & 3 blade available
- Lowest drag when sailing
- The champions choice



747 Aquidneck Ave.
Middletown, RI 02842

401-847-7960

Fax: 401-849-0631

sales@ab-marine.com

www.ab-marine.com

CALL US TODAY!

800-801-8922

SHAFT SHARK

**The best rope,
line and debris
cutter there is!**

Two piece unit

For both power and sail

**Now available for
sail drive systems.**

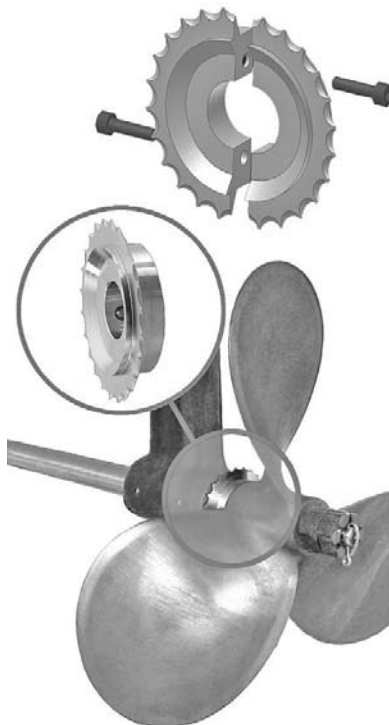

747 Aquidneck Ave.
Middletown, RI 02842

401-847-7960

Fax: 401-849-0631

sales@ab-marine.com

www.ab-marine.com

LETTERS

to *Latitude* for bringing us together!

Before we took Bella to the airport for her flight back to Germany yesterday, we took one last photo as a thank you to *Latitude* for bringing us together. We also gave her a copy of the latest *Latitude* to read on the airplane.

Bill & Kathy Crowley
Clarsa, Newport 23
Napa

↑↓ THERE'S ALWAYS AN 'OTHER SIDE' TO ANY STORY

Being on 'the other side of the story', I must respond to Don Klein's letter in the June *Latitude* about his 35-lb CQR anchor.

I was on the boat anchored near his *Passion* in Los Frailes, and I dove the anchorage a couple of days after he left. After I found the anchor lying in the sand, I put out numerous announcements on the Ham and local nets, offering to return it to the owner. But after four months of no response, I decided to trade it.

When I made an announcement on Swaps and Trades on the local La Paz net, I heard from Don, who told me it was his anchor. He came over and offered me \$25-\$30, which I thought was a pretty low reward, and told him so. He got pretty upset, and took off in a huff. I then traded the anchor, and donated what I received to PATA, an animal humane service that spays and neuters cats and dogs in Santiago, Mexico.

I know that I wasn't being very 'cruiser friendly' in my actions. I guess the main reason was that Don just kinda set me the wrong way. Plus, I had carried the anchor for months, and had put the word out about it many times. I know Don is a hamster who listens to the morning nets, so he must have heard about it. In fact, his wife told me that he had seen the anchor drop off his bow when he was anchoring, and he really didn't care about it. So it kinda irks me for him to now publicly whine about it.

We, too, have saved someone from drowning, also off Los Frailes, and as a vet tech, I have assisted numerous cruisers with their pets, and I have never expected anything in return. This was just a case of a personality problem.

That's my side of the story.

Janice Hawkins
Ceilidh, Pearson 40
La Paz, Baja California Sur

Janice — You tell your side of the story very well, and with an honesty — "I wasn't being very 'cruiser friendly'" — that eliminates any aspirations you might have for political office.

If we were the judge, the fact that he didn't let you know it was his anchor for four months — he didn't make this very clear in his letter to us — would count heavily against him.

↑↓ GREAT HEALTH CARE IN MEXICO

My wife and I did the '09 Ha-Ha on *Willful Simplicity*, our outboard-powered Catalina 27 — possibly the lightest boat to ever do the Ha-Ha. We had an absolute blast, and weathered the strong winds and big seas on the first leg just as well as the larger boats.

We have stayed in Mexico ever since, and have had nothing but positive experiences — until we arrived at Puerto Escondido, where we incurred the wrath of a single cruiser. Our problem was that we didn't follow the 'rules' this relatively newcomer *gringo* had set down for all the good folks at Puerto Escondido to live by. We soon discovered that all the other folks in Puerto Escondido were truly a great bunch of folks who would do anything they could to help others in need. And

*We look forward
to seeing you!*



Doo Dah Host

Imagine yourself in 20 acres of park-like beauty just off the San Joaquin River – channel marker 41.
Imagine your boat at a friendly, clean and relaxing marina.

THIS IS OWL HARBOR!

Monthly Berths and Guest Slips available • Yacht Clubs always welcome

www.owlharbor.com

(916) 777-6055

1550 W. Twitchell Island Road ✦ Isleton, CA 95641

NEWNEWNEW

**World's Best
Holding Tank
Treatment**

- *Revolutionary Microbial Technology*
- 100% All Natural and Bay Safe
- Highly Concentrated
- Advanced Odor Eliminator



Blue Eagle™

Ask your local Marine store,
or go to www.BlueEagleClean.com

Bilge Treatment
also available

Don't leave port without'm!

#1



Servo Pendulum with optional Emergency Rudder

www.selfsteer.com

See over 5000 photos of boats with Windvane installations

Built Locally – Used Worldwide – Sold Factory Direct

We are also the proud manufacturer of:

auto-helm

Auxiliary Rudder/Trimtab,
no lines, emergency rudder

Saye's Rig

Pendulum Trimtab for hydraulic
steering/high freeboard

SOS Emergency Rudder

Stand-alone, stows under
deck, just like your life raft

We can supply the RIGHT Windvane/Emergency Rudder for your boat



Point Richmond, CA
510.215.2010
888.946.3826
scanmar@selfsteer.com

UNSURPASSED FACILITIES

Ultra-wide slips and innovative concrete docks with round fingers. Beautiful restrooms and showers, and plenty of parking.



CONVENIENCE

All slips feature double 50-amp 125/250V power, free dock box, DSL phone line, and pumpout at every slip. Parking, WiFi and ice are complimentary.



LOCATION

Located in the heart of Silicon Valley, Westpoint Harbor is close to San Francisco and San Jose airports, and minutes from historic downtown Redwood City. At 50 acres, Westpoint Harbor is one of the largest recreational marinas in Northern California, and enjoys more than 300 sunny days per year.



"Westpoint Harbor is a one of the friendliest harbors we've ever kept 'Illusion'. From the first day, we were welcomed into its warm supportive community of sailors and power boaters. Conveniently close

to home and easy, all-tide access to the Bay makes this a perfect place to re-fit and enjoy the South Bay sunshine. Thanks to Westpoint for their incredible support for the America's Cup video testing."
— Stan and Sally Honey

www.westpointharbor.com

650 224-3250

1529 Seaport Blvd., Redwood City, CA 94063

LETTERS

for free, too!

More recently, we've been in La Paz, which is the friendliest and most helpful community we've ever encountered. We've developed many close friendships.

On January 25 last year, I injured my back to the point that I was actually paralyzed. When we called Dr. Tuchmann, a local doctor, he not only came to our boat to check me out, but he absolutely went into overdrive to see that I would recover. The doctor determined that I needed to see an orthopedic surgeon, so he brought Dr. Mondragon, one of the top surgeons in Mexico, out to our boat to examine me!



STEVE BAKER

Charlotte and Steve Baker have loved cruising Mexico . . .

To make a long story short, I had an MRI to confirm what they suspected was wrong. So they set up a surgery team of three doctors and assorted nurses to see me through six hours of complete back reconstruction surgery. I have since fully recovered, and my back is in better condition than before the surgery. What an absolutely fantastic and unbelievably positive experience — at probably one-tenth of what it would have cost in the States!

Based on my experience, the medical care in Mexico is fantastic, and puts U.S. medical care to shame. As a case in point, all the doctors I've seen in Mexico — including specialists in Guadalajara — have had us put their numbers in our cell phone so we can reach them personally, any time of day or night. And they have answered their phones each and every time we've had reason to call them. The doctors have also called other doctors to make appointments for me. I could go on and on about the quality of care.

Another high note of cruising in Mexico has been our adopted family. Actually, it's a family in the fishing village of San Evaristo 55 miles north of La Paz — and they adopted us. We generally spend December, January and February in San Evaristo, and make a monthly trip to La Paz for supplies. Our adoptive family there made us the godparents of their newest child. We have been truly honored!



STEVE BAKER

. . . on a Catalina 27!

We want to thank everyone at *Latitude 38*, and especially the publisher, for having fueled the dream for many of us with the writing in *Latitude*, and encouraging us that we 'can do it', no matter if our boat is large or small. We know you'll say "gashaw", but it's true.

We are loving cruising in Mexico, and plan to continue.

Steve & Charlotte Baker
Willful Simplicity, Catalina 27
Sausalito

Steve and Charlotte — Gashaw. But thank you very much for the kind words.

↑↓ U.S. HEALTH CARE COMES SECOND TO NO ONE

I have read different reports in *Latitude* comparing medical care in foreign countries to that in the United States.

Midsummer **SPECIAL**

HARKEN

FURLING

July only – FREE rig tune and inspection with purchase and installation of Harken furling.

Reliability comes with Harken and Easom.

\$500 value!

Easom Racing and Rigging

1230 Brickyard Cove Rd. Suite 102
Point Richmond, CA 94801

(510) 232-SAIL (7245)

www.easomrigging.com



COASTAL
BATTERIES



The only AGM L-16
400 AMP hour completely
manufactured in the USA

150 AMP
hour
group 30



MAGNUM
INVERTERS

**CUSTOM
BATTERY
CABLES
& LUGS**



Crafted for
quality in
the U.S.A.

- Serving all of Orange County
- Free Dockside Delivery
- Free Core Pickup
- Custom Battery Cables
- Fully-Stocked Warehouse for Same-Day Delivery
- Battery Service & Charging Available
- Will-Call Available

COMPLETE LINE OF WET CELL BATTERIES AVAILABLE

1725 Monrovia Ave., Unit B3
Costa Mesa, CA 92627

949-722-1027
Fax 949-722-8406

distributor for
LIFELINE
...the heart of your system®
PREMIUM AGM BATTERIES

Store Hours: 8:00 am to 4:30 pm Monday thru Friday

YES!

Mechanical fittings? **STA-LOK!**

Swage fittings and Turnbuckles? **STA-LOK!**

Available in the US and Canada? **STA-LOK!**

Awesome quality? **STA-LOK!**

You already know us for our mechanical fittings; they've been around for some 35 years or more. But did you know that Sta-Lok manufactures a wide range of swage fittings and turnbuckles too? And they're the same fantastic quality as our mechanical fittings. So now you know!

The answer's **STA-LOK!...**

...Now, what was your question again?

STA-LOK Sta-Lok Terminals Inc.
(910) 399-5206

www.stalokinc.com info@stalokinc.com

2725-1B Old Wrightsboro Road, Wilmington, NC 28405

LETTERS

I have been in the international medical business — clinical laboratory diagnostics, orthopedics, cell transplantation — for a quarter of a century and believe that I know the medical systems in foreign countries quite well. Due to my extensive and long-time travels, I also have received medical treatment abroad. Living in the United States, I am also a consumer of United States medical care — and I am making a distinction between 'medical care' as practiced by physicians and administered in hospitals versus 'health care', which encompasses all the other aspects of health, e.g. long-term care, elder care, and so forth.

To understand the medical care cruisers receive abroad and the associated costs, you have to understand the health care system. In most countries of the world — with the exception of the United States and Switzerland — there is universal health care based on insurance to which all but the most affluent must subscribe. The physicians get reimbursed by the national health care insurance. The patient never sees a bill. In some countries, the physicians get a quarterly sum for each patient who is listed with his practice. For this sum the physician has to treat the patient.

Very few patients are in the position to be privately insured because of the local laws governing health insurance. Privately insured patients or non-insured patients are directly billed by the physician at a rate which is often three times or more the rate he receives for the same treatment from the national health insurance. Those privately insured patients or patients without insurance are the money makers for the physician. That's often the icing on the financial cake — and such payments are often in cash. So, there is a two-class system of medicine: one for those with money, and one for those belonging to the national health insurance.

Cruisers fall into the category of patients with money. It is understandable that they are well-served and experience immediate treatment. In some countries there are even separate waiting rooms for these patients.

Now, let's address the treatment. What can you expect to be well-treated for when abroad? Usually the conditions which the physicians encounter daily in that area, such as staph infections in the tropical areas of the world, diarrhea, trauma, etc. But if you have diffuse abdominal pain, a broken hip or ankle, need knee replacement or involved dental treatment like a root canal or implants, I would advise you to seek medical treatment in one of the industrialized nations, such as Australia, New Zealand, Central Europe or preferably the United States. Yes, the United States, because we have the best medical care in the world — if you can afford it. Worldwide, the United States is the standard to which reference is being made, either by medical education or postdoctoral training in a speciality.

The U.S. system is expensive because of the wages, the high degree of specialization (which guarantees superior outcome), inefficiencies, and defensive medicine. With regard to the last point, in the U.S. we do two to three times the number of laboratory tests per patient compared to Germany, the country that does it at the next highest rate. Most of the tests are unnecessary, but are required as defensive tools should a complication arise. If they're not done, the lawyers will point to substandard treatment and ask for a large compensation.

Just one more point of reference: In the United States, we spend about 16-17% of Gross Domestic Product on health care versus 6-7% in Germany. France, the United Kingdom and Japan are all lower.

My message to cruisers who need medical care abroad: enjoy the low cost, choose well what you want to have done,



COAST MARINE

& INDUSTRIAL SUPPLY INC.
398 Jefferson St. San Francisco - On the Wharf.

Call **Bruce Becker: (415) 673-1923**
800-433-8050
Fax (415) 673-1927



LIFE RAFT

Sales & Service

U.S.C.G. Approved Testing Facility

- ★ U.S.C.G. life raft facility for Solas commercial yacht and fisherman rafts
- ★ COMAR DEBARKATION LADDERS
- ★ COMAR PILOT LADDERS
- ★ COMAR WORK LADDERS
- ★ All U.S.C.G. approved



GUINNESS WORLD RECORD "World's longest tested ladder 320ft."

Major Distributor for:



IN SAN DIEGO CALL OCEANS WEST 619 544-1900



OYSTER POINT

Marina/Park



A full service marina located in South San Francisco with berthing and guest dockage available

For information and pricing call
(650) 952-0808
www.smharbor.com/oysterpoint

Family. Friends. Fun. This is Harbor Sailing.



H¹⁴ H²⁰ H²⁵ H³⁰

BOAT BUILDERS
W.D. Schock CORP.

Inland Sailing Company
Sacramento
www.inland-sailing.com

The Chandlery Yacht Sales
Santa Barbara/Ventura
www.chandlery.com

The Yacht Exchange
Marina del Rey/Los Angeles
www.theyachtexchange.net

South Coast Yachts
San Diego
www.scyachts.com

W. D. Schock Corp • 13,000 boats since 1946 • 951-277-3377 • www.wdschock.com • schock@wdschock.com

Come to Mexico and repair your boat at

OPEQUIMAR
MARINE CENTER CENTRO MARINO

Puerto Vallarta



88-ton (max)
Travelift!
Length to 100'
Width to 23'

México AEROTRON www.aerotron.com RIVIERA NAYARIT El Tesoro del Pacífico Mexicano PUERTO VALLARTA Where Mexico Comes to Life

www.opequimar.com

fuel dock • full service boatyard • brokerage • 88-ton Travelift



FREE QUOTES

**10,000 SAILS
IN STOCK**

www.BaconSails.com

Search online – list updated daily

BACON SAILS AND MARINE SUPPLIES

116 Legion Avenue Annapolis MD 21401

(410) 263-4880

MARINE LADDERS

DEPLOYABLE FROM THE WATER



THE LINKS MAKE IT RIGID

- Electropolished 316 Stainless
- Easily Extended and Collapsed
- Rigid - Will Not Kick Under



UP-N-OUT
ULTIMATE MARINE LADDERS By Scandia Marine Products



www.scandiamarineproducts.com
or call: (651) 433-5058

LETTERS

and keep in mind you have always a fall back position to the best place for medical care — home in the United States.

Richard Leute, Ph.D.
Acey Deucy, J/44
Sausalito

Richard — We'll agree that if money is no object and you're far enough up in the elite to be treated by the best doctors in New York City and several other centers, you're probably going to be availing yourself of the best medical treatment in the world. Unfortunately, most cruisers can't afford the best doctors, even in the unlikely event they have the connections to gain access to them.

Based on our experience, we've found any correlation between expensive health care — such as in the United States — and successful outcomes to be suspect at best. We once suffered a nasty ankle injury. Despite the considerable pain, we called the hospital to ask when they'd be the least busy, believing that we'd get the best treatment then. We showed up at 7 a.m. the next morning, as advised. We were diagnosed as having a sprained ankle, and had the x-rays reviewed by a specialist. When things didn't get better after 10 days, we visited another doctor. Looking at the very same x-ray from a distance of about 10 feet, he said, "Well, you obviously have a broken ankle."

On another occasion, we were diagnosed as having a herniated disc by the Navy hospital in La Paz, at which point they medicated us and put us on a stretcher for a flight to LAX. We were taken to the L.A. Orthopaedic Hospital, where the doctor's diagnosis, as explained to our then-wife, was: "He's faking it." It was weeks of extreme pain before we were able to see another doctor who, although not a big believer in surgery, highly recommended that we go under the knife that evening. Thank god we did.

We're not going to slag all U.S. doctors, as we think there are many excellent ones, and that many of them got into the field more to serve than to profit. But unlike people in the medical field such as yourself, we and most other readers get treated by average U.S. doctors. In our opinion, and that of a lot of nurses we know, there are many doctors in Mexico and other countries that are just as good as, if not better than, those in the U.S. and Canada. And more importantly, these Third World doctors seem to be more personally involved with their patients. We hear this again and again.

While it's true that we've gotten a couple of cruiser reports of substandard medical treatment, the overwhelming number of reports rave about the high quality of the care, the low cost, and the much more personal attention.

For what it's worth, we're convinced that single-payer health care is the best possible system. But only in theory, as the United States government has become so inefficient, incompetent and corrupt — as the heavily subsidized U.S. Post Office's inability to compete with FedEx so well demonstrates — that we fear the cure would be worse than the disease.

↑↓ "CATS ARE BETTER"

Now that we've started our second cruise, this time on a Spindrift 43 monohull rather than the Wildcat 35 catamaran we did our circumnavigation on, much of my writing over the next few weeks is going to revolve around comparing our monohull with our catamaran.

Nobody ever goes from owning a catamaran to a monohull. It's unheard of. And, it turns out, for good reason. The fact of the matter is that cats are better. They are also three times as expensive. Not twice as expensive, but three times. So after

Antares 44ⁱ

THE WORLD'S BEST LIVEBOARD



Glass windshield, complete engine instrumentation, and weather enclosure make the Antares a true all-season catamaran.



613.544.9283 www.liveantares.com info@liveantares.com
Toronto Charleston Buenos Aires



INSURING YACHTS FOR OVER 50 YEARS

Providing Cruisers and Racers All Over the World with Prompt, Reliable Service since 1959

Contact Us for a Quote

Exclusive MARINERS *Odyssey*® Program
 Mexico
 South America
 South Pacific
 Caribbean
 Mediterranean

Racing Sailboat Program
 TransPac
 Pacific Cup
 PV / Cabo Races
 Caribbean Regattas

www.marinersins.com

N. California
 boomeins@aol.com
 800-853-6504

L.A./Orange Co.
 800-992-4443

San Diego
 800-639-0002

Seattle
 800-823-2798



QUALITY COVERAGE AVAILABLE IN MEXICO
 Mariners Insurance Mexico offers insurance programs for health, homes, autos, motorcycles and yachts in Mexico.
www.marinersmexico.com

Corporate Office: 206 Riverside Ave., Suite A, Newport Beach, CA 92663 / Ins. Lic. #0D36887

Puerto Vallarta
 52-322-297-6440
 East Coast
 Bradenton, FL
 800-914-9928

BETA MARINE WEST:

Your Exclusive Distributor of
 Beta Marine Diesel Engines and Generators
 For the ENTIRE West Coast -
 Washington, Oregon, California and Hawaii

Visit us
 at our new
 location!

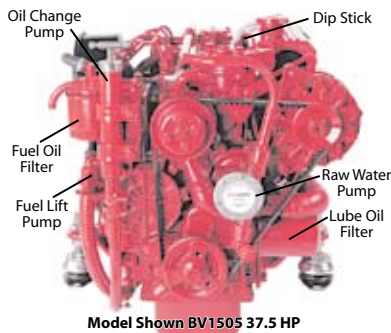

HIRSCHFELD YACHT

Marine Repair and Installation Specialists
 Full Service Shop with Dockside Access

- Electrical
- Generators
- Controls
- Engines
- Inboard/Outboards
- Installation
- Outdrives
- Propellers
- Transmissions

www.betamarinewest.com

415-332-3507

New address! 400 Harbor Drive, Sausalito 94965

frigoboat®

KEEL COOLER SYSTEM

- No Pump
- No Fan
- No Noise

Arguably the world's most efficient, dependable refrigeration. The keel cooler and super efficient compressor make for a quiet, highly efficient 12V refrigeration system.



More than 12,000 Keel Cooler systems sold in the last 10 years. Designed for hot, tropical conditions.

Dealer Inquiries Welcome



SWEDISH MARINE

1150 BRICKYARD COVE RD., SUITE B6
 PT. RICHMOND, CA 94801 (510) 234-9566

Yacht at Rest, Mind at Ease

DYT DOCKWISE YACHT TRANSPORT

WORLD CLASS YACHT LOGISTICS

DYT USA: Tel. +1 954 525 8707 • E-mail: dyt.usa@dockwise-yt.com
 WWW.YACHT-TRANSPORT.COM • 1-888-SHIP-DYT (744-7398)

LETTERS

33,000 miles going around the world on our cat, and 100 miles on a monohull, my advice is this: If you can afford the cat without delaying your trip or cutting into the time you will be able to spend out cruising, then by all means, buy that dream cat of yours. But if you can buy the monohull and get out cruising now as opposed to having to spend a couple more years working to buy the cat, then just get the mono and get out there. It's as simple as that.

Our Spindrift 43 monohull isn't nearly as comfortable on the water as was our cat. At least in today's conditions. We had a big swell on our beam most of the day, which caused us to roll around quite a bit. The cat would have floated up and over these swells without our even noticing. Once the wind was dead behind us, our monohull actually rode nearly as nicely as our cat would have. But every few minutes, a wave would catch her just a little off, and throw us a little to the side, causing a nice big roll from one side to the other, then and back again. The boat does roll nice and slowly though, leaving us enough time to support ourselves before she completes the process.

Overall, I didn't hate the motion nearly as much as I'd expected to. In fact, I didn't really mind it at all. Ali, who is pregnant, did really well, too. Although she once laughed at the motion and said, "This is stupid." I think that sums up the motion of a monohull in one simple sentence.



LATITUDE / LADONNA

The 'Bums' don't pussyfoot around — "Cats are better," they say.

As for our 18-month-old Owest, she didn't care. We had to keep one hand on her at all times, because she isn't really understanding what is happening yet. But I did see her brain working a couple of times when she decided to crawl for something rather than stand up and walk. She'll get it.

What else did we learn our first day out? We figured out that we need plates and bowls with rubber bottoms on them to keep from sliding all over.

We learned that in roly seas, Ali will not be cooking anything on the stove. I figured out that peeing off a monohull is not nearly as easy as peeing off a cat.

We found that Ali did a good job of organizing the boat, as we didn't have anything fly out of cabinets, and when we did open cabinets to get something, nothing fell on us.

I also learned why monohull sailors are so worried about safety. It's because these roly beasts are not nearly as safe and secure as a cat. You really do need to have one hand holding onto the boat at all times because at any second she can roll and send you running full speed across to the other side. With the cat, we could wander around on deck as if we were on land — even in rough seas.

I also discovered that we need a dodger, if for no other reason than as a place to attach handholds. I have also discovered that having a dodger — even one with windows — is going to completely obliterate any view we have from the cockpit.

But most of all, we figured out that cat or mono, it doesn't really make much difference — as long as we are out here. Cruising along the wild California coast, watching the swells smash against the rocks on shore, watching the dolphins play around us, and watching my daughter stare through the netting at the water rushing past her makes it all worthwhile

DISCOVER WHAT CRUISERS HAVE LEARNED

To outfit your Blue Water Adventure, go to **DOWNWIND MARINE**. The Cruiser's Chandlery, where you will find extensive experience and great value!

Official Sponsor
 2011
 BAJA
 HA-HA

THREE STORES TO SERVE YOU

All with Online Convenience!



THE CRUISER'S CHANDLERY

www.downwindmarine.com
 2804 Cañon Street
 San Diego, CA 92106
 (619) 224-2733
 (866) 289-0242



www.sandiegomarine.com
 2636 Shelter Island Drive
 San Diego
 (619) 223-7159
 (800) 336-SDMX
 Mexico 001-800-336-7369



www.sailingsupply.com
 2822 Cañon Street
 San Diego, CA 92106
 (619) 225-9411
 (800) 532-3831

We are a great family of marine stores with even more service, websites, and resources to meet all of your boating needs.

COME VISIT COYOTE POINT MARINA

The Peninsula's Complete Recreational Destination!



LIEN SALE
Saturday, August 20
12-2 pm



Multihull
 side ties available
 up to 40 ft.

BERTHING

- Slips to 40' available
- Inside ties from \$100 per mo.
- Multihull side ties available
- Check out our rates!



FUEL DOCK & PUMP OUT

- Open 7 days per week
- Gas and diesel available
- Check our prices
- Free pump outs

COYOTE POINT MARINA ~ 1900 Coyote Point Drive • San Mateo

650.573.2594

BOSTON
WHALER

HONDA
MARINE

Powered by reliable and fuel efficient
 Honda 4 stroke outboards

Visit our
ACCESSORIES SHOWROOM



Costco Members Specials
on new select Boston Whalers!

- Great inventory
- Great prices
- In store
- Online

REPOWER
SPECIALS!

We have a large selection of outboards
at Special Prices! Now is the time to
repower your boat and SAVE!

Always wear a personal flotation device while boating and read
 your owner's manual. ©2011 American Honda Motor Co., Inc.

Outboard Motor Shop

(800) 726-2848
(510) 533-9290

1926 - 2011
 Your Bay Area Dealer
 For 85 Years
 333 Kennedy Street
 Oakland, CA 94606
www.outboardmotorshop.com

All Prices INCLUDE freight & prep, plus tax & license only.

3003



The secret to our beauty
 is nuts.

(No, really. It's nuts.)

One of the reasons our hardware is
 as beautiful as it is strong is that we
 tumble it for up to 24 hours in a
 machine full of pellets made from
 walnuts among other things.

The results speak for themselves.

SCHAEFER
 LEGENDARY STRENGTH

508.995.9511 SCHAEFERMARINE.COM



LETTERS

no matter what kind of boat we're on.

Pat & Ali Schulte
Bumfuzzle, Spindrift 43
Minneapolis, MN

↑↓ WEAR BUG SPRAY AND PICK YOUR RIDE CAREFULLY

As *Latitude* knows, it's a very good idea to go through the Panama Canal as a line-handler before transiting with your own boat. The practice run gives you a feel for the trip and, as you again know, going through as skipper is way too stressful to be enjoyable.

We hung around the yacht club for several days before getting a ride, and were lucky in that we knew a number of people who were making transits. I'm not sure how much luck backpackers would have landing line-handler positions. One of the boats we knew was owned by a singlehander who is a frequent contributor to another U.S. sailing magazine, and who asked us to come with him.

This singlehander was not really prepared to have four people — all boats making a transit must have a helmsman



COURTESY MOONRISE

Line-handling for other boats is a great way to get experience for your own transit.

and four line-handlers — spend the night on his boat in Gatun Lake. For example, he ran out of water — something you really need in Panama — on the second day. We also learned that dogs don't like strangers on their boat, especially at night. And, that nobody likes cockroaches scuttling over their bodies in the dark. In other words, don't be overly keen to get on just any boat. Carefully evaluate the skipper and boat before agreeing to go along.

We learned the following as well: It's very scary going into a lock behind a ship, and being caught in the turbulence when it leaves the lock. Spray yourself with mosquito repellent before going into the lock, as it's hot and there's no wind down there. Cover solar panels and other delicate items with cockpit cushions and other protection. The monkey fists thrown down are heavy and will break a panel. Don't assume that your pilot/advisor is competent. If you tie alongside another yacht, you are relying on the skipper and crew of that boat to keep your boat off the harsh lock walls. Lastly, we were very surprised at how scenic the Canal is, as other than going up or down in the locks, you motor nearly 30 miles across a jungle forest that is half-flooded by a man-made lake.

After a lot of thought, we decided to pay an agent to do our paperwork, even though it cost a lot more. One reason is that the lines and fenders were included in the price, and we wouldn't have to take the lines back to Colon. In addition, it allowed us to clear out of Panama from Colon without having to do more paperwork in Panama City. And I believe that having an agent meant we got a quicker transit.

By the way, Jetti Matzke and I are back in Oakland for a few days, having spent our third winter sailing in the Bahamas. But we're about to drive up to British Columbia for six months of sailing there. No matter where we go, we read *Latitude* and *Lectronic* online.

Richard Woods
Woods Designs

Richard — At the risk of sounding like a pompous ass, we

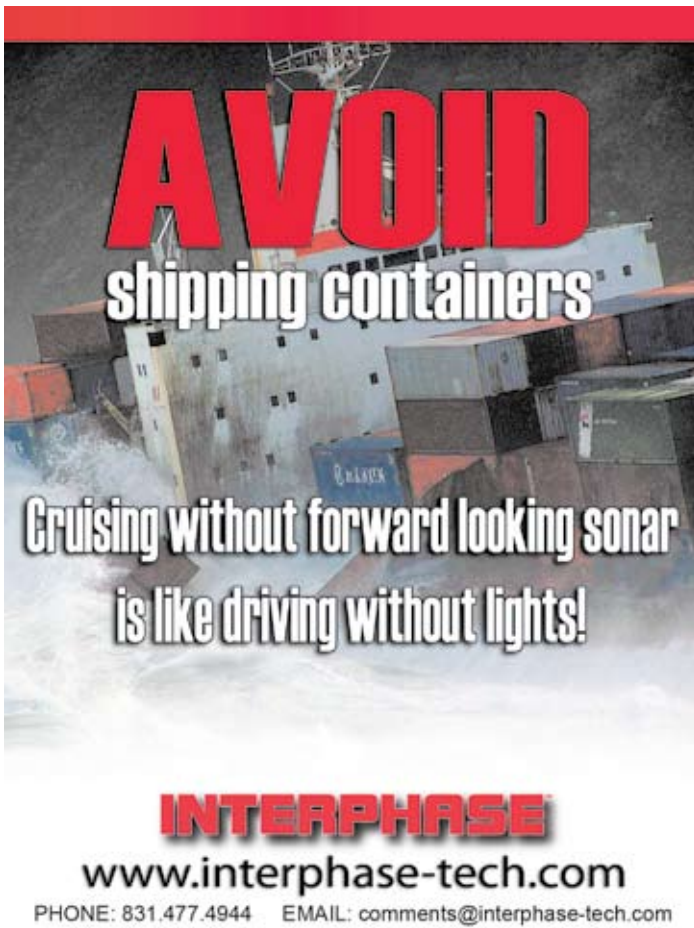

AVOID
shipping containers

Cruising without forward looking sonar
is like driving without lights!

INTERPHASE
www.interphase-tech.com

PHONE: 831.477.4944 EMAIL: comments@interphase-tech.com

BOAT LOANS

Unbeatable rates.

New / Used / Refinance

Call us today
for a free quote.

(800) 233-6542

San Diego, Newport Beach, Alameda & Seattle



www.seacoastmarine.net

A division of Seacoast National Bank.



MODERN SAILING SCHOOL & CLUB

Sausalito, CA www.ModernSailing.com (415) 331-8250

Get your Captain's License

August 8 - 20
2 week intensive

OUPV LICENSE - \$995
100 TON LICENSE - \$1195

Our GUARANTEED, U.S. Coast Guard Approved course will prepare you for all elements of the exam, guide you through the application process, and conclude with on-site testing.



you through the application process, and conclude with on-site testing.

Gain Advanced Certifications in Exotic Locations with John Connolly

CARIBBEAN - FALL 2011

LEG 1: November 26 - December 6, 2011
(St. Martin to Antigua)

LEG 2: December 9 - 19, 2011
(Antigua to St. Martin)

Cost
\$2175 / berth
\$3950 / cabin

**ASA 106 Available
on Both Legs!**



Upcoming Events

- July 4** - Fireworks Member Sail (4:30 - 10pm)
- July 8, 15, 22, 29** - Jazz and Blues by the Bay (6:30 - 8pm). FREE - but RSVP required.
- July 14** - Dinner and a Sail (5 - 10pm). RSVP Required.
- July 16** - Night Sailing Clinic (6 - 10pm) Call to register.
- July 30** - Sail Trim Clinic (9am - 4pm) Call to register.

ASA OUTSTANDING SCHOOL 2009 & 2010



Custom Canvas & Interiors



The Gianola Family has been designing and fabricating custom canvas and interiors since 1969. Gianola Canvas Products offers you the best in quality, more choices, and personal service.



265-B Gate 5 Road
Sausalito, CA 94965
(415) 332-3339
www.gianolacanvas.com

McDERMOTT COSTA

insurance brokers - est. 1938

Commercial Operations

- COMMERCIAL POLICIES
Marinas, Yards,
Yacht Clubs,
Brokers,
Shipwrights

Pleasure Yachting

- YACHT & BOAT POLICIES
Offshore, Coastal,
Inland and
Liveaboards



Lic. #OB21939

Bill Fowler
McDERMOTT COSTA INSURANCE
(510) 957-2012 Fax (510) 357-3230
bfowler@mcdermottcosta.com



Can you trust your anchor to hold in all conditions?

Ultra Anchor is certified by the American Bureau of Shipping (ABS) to meet their highest level of holding power for use on ABS class vessels.



"Get an Ultra Anchor—
Don't let this happen to you!"

Please stop by and see us at the
San Diego Yacht and Boat Show—July 14-17



8700 Warner Ave., Suite #110, Fountain Valley, CA 92708
www.ultraanchors.us • sales@quickline.us • 714-843-6964
The World's Highest Quality Marine Products.

RICHARDSON BAY MARINA formerly Kappas Marina

MODERN FACILITIES IN A WELL-PROTECTED HARBOR

Concrete Dock System

Well Maintained Facilities

Beautiful Surroundings

- DEEP WATER BERTHS: BASIN AND CHANNEL DREDGED
- CARD KEY SECURITY SYSTEM
- DOCK CARTS
- PUMP OUT STATION
- AMPLE PARKING
- CLEAN SHOWER AND TOILET FACILITIES
- WITHIN WALKING DISTANCE: MARKET/DELI, LAUNDROMAT, RESTAURANT
- AT EACH BERTH: LARGE STORAGE BOX, METERED ELECTRICITY, PHONE HOOKUPS, WATER

BERTH YOUR BOAT IN SAUSALITO

415 332-5510 www.richardsonbaymarina.com
100 Gate Six Road, Sausalito • Fax 415 332-5812

LETTERS

took our Ocean 71 Big O through the Canal without doing a practice run as a line-handler, and didn't find it any more stressful than a lot of things we've done in sailing. The only part we didn't enjoy was when Don Antonio des Mortes, our captain, refused to heed the Canal Authority's insistence that we spend the night at Gatun Lake.

"No," he told the Authority over the VHF, "we're going to do the transit in one day, and I'm turning off the VHF so the matter can't be discussed any further." We fully expected to be arrested and have our boat impounded when we got to the Miraflores Lock. Not only did we not get arrested, but a Canal pilot happily sent us a photo he'd taken of Don Antonio doing another unthinkable thing — passing the ship the pilot was commanding in the narrow Gaillard Cut. How Don Antonio was always able to get away with stuff like that is beyond us.

We also did a transit with Profligate, and it's our feeling that the most important thing in a transit is that the line-handlers — both on the boat and on shore — pay attention.

We've used agents to do the paperwork for a Canal transit, and we've done it ourself with the help of taxi drivers. For those who have more time than money and enjoy adventure, we recommend the latter.

↑↓ MULTIHULL SALES ARE PICKING UP

It would come as no surprise to *Latitude* readers that the business of selling boats this past couple of years has been grim. So it seems worth mentioning that, in the past six weeks, I've seen evidence of a real turnaround. I work at West Coast Multihulls in San Diego, and in the last six weeks we've sold the following multihulls: a 2000 Privilege 37, a 2008 Seawind 1000XL, a 2011 Lagoon 400, a 1991 Corsair F-27 and a 2007 Corsair Sprint 750. Too bad the Privilege 49 I had listed burned in Turtle Bay last fall, or I could have sold that, too. I found it interesting that buyers of both the Privilege and the Seawind intend to cruise Alaska.

We're also making changes for what would have been our Sixth Annual Seawind Rally to Catalina on August 18-21. Previously it was only open to Seawind cats, but this year we're opening the rally up to all multihulls, and are therefore looking for a new name for the event. We'll keep you posted.

Monte Cottrell
San Diego

↑↓ THE TROUBLE WITH RUM

Unless I forgot someone, there were 17 of us who descended on Antigua for Antigua Sailing Week to celebrate life, boats, and my birthday. We



DAVID YOUNKMAN

Just one of the many excellent meals, but where's the rum?

I heard, the rumored trouble with rum began.

We went sailing every day to catch the start of the daily races, then it was off to swim, sail some more, and drink rum. The racing was excellent. We primarily rooted for *Jaguar*, a Frers 43 that was berthed just down the dock from us. It was fairly windy for the Wednesday race, and we saw two or three

RED IS READY

The **RED** Boats of BoatU.S. are ready to come to your aid 24/7 when you need assistance on the water. We're just a VHF radio or phone call away to assist with a tow, soft ungrounding, a jump start, or even when you've run out of fuel. At the first sign of trouble, give BoatU.S. a call... we're standing by. Get Unlimited Towing for just \$149 a year!



VESSEL ASSIST
Towing You Can Trust From BoatUS



To Join, Call **800-888-4869** or **BoatUS.com**

*Service provided during normal boating seasons. Details and exclusions can be found online at BoatUS.com/towing or by calling. \$149 includes required \$24 Membership dues.

KISSINGER CANVAS

Marine Canvas & Interiors
STEVEN KISSINGER
(925) 825-6734
Covering the Entire Bay Area



- Biminis
- Boat Covers
- Cushions
- Sail Covers
- Headliners
- Awnings

DODGERS

Side handrails and window covers included.

OPTIONS

Aft handrail, dodger cover, sailing bimini.

Free Estimates and Delivery

SAVE
on North Sails
quality, durability
& performance!

NORTH SAILS
direct

It's easy to measure your own boat and SAVE on the world's best cruising and racing sails. Log on to northsailsdirect.net or call **888-424-7328**.

Free tape measure with every order!



MARITIME INSTITUTE

Would You Like to Become a Licensed Captain?



Maritime Institute Has a Course Near You!
From **San Rafael** to **San Diego**
or **On-line** At Your Own Pace

What are the benefits of having a Captain's License?

- ✓ Improve Your Navigation Skills
 - ✓ Increased Safety for Family and Friends
 - ✓ Option to Take Passengers for Hire
 - ✓ Better Insurance Rates
- ... Plus, the **PRESTIGE** that comes with being a Licensed Captain!

Call Today 888-262-8020
www.MaritimeInstitute.com

LETTERS

spinnakers get shredded. It was a pretty exciting sight.

Each evening we'd go down to Nelson's Dockyard or a party up at Shirley Heights. Nelson's Dockyard, an impressive and



DAVID YOUNKMAN

Antigua Sailing Week was just what the doctor ordered for that special "big" birthday.

intact Georgian-era English boatyard, easily brought back memories of pirate times — except for the long quay of high-tech Swans docked side-by-side. The locals couldn't have been nicer, and they had tents set up where they sold wonderful fish, BBQ and cold beers. The best meal of the trip, and there were many excellent meals, was the 'tasting menu' we pulled together from as many of the vendors as we could manage.

The raucous parties weren't as wild as their reputation, but perhaps we missed some of them because we were celebrating a birthday of a really big number, and, of course, there was the trouble with rum. There is a rumor that drinking it can make you sleepy.

Anyway, hats off to the Antigua Race Committee, the Catamaran Hotel, and Horizon Yachts for an excellent pirate adventure.

David Younkman
Falls Church, VA

David — This year's was the 44th Annual Antigua Sailing Week, an event that back in the day — meaning the late '80s and early '90s — established the gold standard for wild regattas in the tropics, with nearly 250 entries. We did six of them with Big O, and will never forget the challenging racing or the outrageous parties.

Then, for whatever reason, Sailing Week seemed to slip a bit, at least compared with the growing Heineken Regatta in St. Martin and the Antigua Classic Regatta. It took a real punch a few years ago with the big slump in the world economy. There have been some changes to the event since, notably that all the



WEBB LOGG

Reggae fusion artist Maxi Priest packed in the crowds at Antigua Sailing Week.

races are now held on the south coast of the island instead of being around-the-island races, and the overnights in Dickenson Bay and Jolly Harbor. And as opposed to the wet t-shirt contests and wild freestyle partying each night around all the race venues, this year Maxi Priest put on a show up at beautiful Shirley Heights for an appreciative crowd of 2,000. Best of all, we're told that the once-tense vibe around English Harbor has mellowed out a lot.

Anyone wishing to get an idea of the spectacular tropical sailing conditions to be found off of Antigua should go to the Sailing Week website and check out the videos. Good stuff.

↑↓ **DON'T BE TALKIN' SMACK ABOUT CATALINA!**
Naysayers Beware!



SEASHINE

MORE SAILING, LESS WORK

Service of the Month

CARPET & CUSHION CLEANING

Professional, dockside cleaning that will leave your boat looking and smelling like new!

ADDITIONAL SERVICES

Interior Cleaning • Maintenance
Detailing • Washdown • Polishing

Fully Insured & Marina Approved

Since 1986

Call now for a Free Estimate

(510) 428-2522 or (415) 457-6300

www.seashine.net



LEUKEMIA & LYMPHOMA SOCIETY | LEUKEMIA CUP REGATTA

AS IT TURNS OUT, THE WIND IS AS EFFECTIVE AT DRIVING BLOOD CANCER BACKWARD AS IT IS AT DRIVING A BOAT FORWARD.

Raise a sail and save a life. The sixth annual Leukemia Cup Regatta benefitting The Leukemia & Lymphoma Society is at The San Francisco Yacht Club in Belvedere, CA.

October 1st VIP dinner

Speaker: John Doerr, partner at Kleiner Perkins Caufield & Byers

October 2nd Leukemia Cup Regatta – [Register at leukemicup.org/sf](http://leukemicup.org/sf)

Your secret paradise...

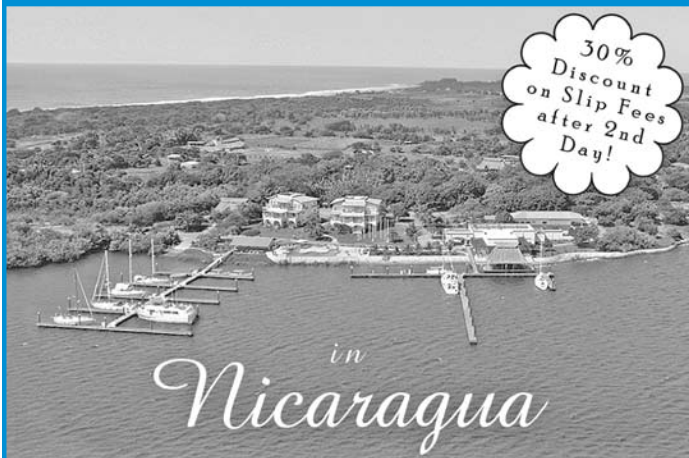

30% Discount on Slip Fees after 2nd Day!

in *Nicaragua*

Located in a beautiful sheltered lagoon on the north Pacific coast of Nicaragua, Marina Puesta del Sol is your premier cruising destination in Central America.



Marina Puesta del Sol

RESORT

Aserradores, Nicaragua ♦ 011 (from US and Canada) 505-8880-0019
info@marinaps.com ♦ www.marinapuestadelsol.com ♦ USA 408-588-0017

License #OE32738

TWIN RIVERS

MARINE INSURANCE AGENCY, INC.

"Your Boat Insurance Specialists"

7 Marina Plaza • Antioch, CA 94509

At The Antioch Marina



Worldwide Coverage

- West Coast
- Atlantic
- Mexico
- East Coast
- Pacific
- Caribbean

Representing...



CHARTIS

TRAVELERS



MARKET INSURANCE COMPANY

ace seguros

ace recreational marine insurance

Shop Your Renewal & Save • Flexible Survey Requirements

Insurance made simple, affordable and effective.

Broad Navigational Areas • Liveaboards

Years of unbeatable experience to match your needs to the right product.

Agreed Value Policies • Fuel Spill Liability

www.BoatInsuranceOnly.com • (800) 259-5701

LETTERS



Marin
 Convention & Visitors Bureau
 visitMarin.org
 866.925.2060

Watch the best
 sailors in the world
 on our bay . . .

How dare *Latitude* demean the mighty Catalina Island, whose muses always lure us to her shores?

Having spent much time sailing our Cal 20, then Cal 25, then Newport 28, to every possible harbor and anchorage on both sides of Catalina for over 10 years, I can attest to its many gorgeous coves and diving spots.

I guess the real secret is to escape during the week, as Southern California's masses seek refuge at the island on weekends. Of course, much depends on who your crewmates are, what you bring to eat, and what activities you plan.

We've taken newborns — two weeks old — to the island, bringing the playpen in the dinghy. Our sons grew up sailing to the island, and still enjoy it.

The Channel Islands provide even more exploring and fun! There is a pure treasure trove at our beck and call. So heed to it, matey, and explore life all the more!

Christine Thomas
 Southern California

Christine — We bet you can't wait for Talk Like a Pirate Day, which is September 19.

You almost make it sound as if we wrote something negative about Catalina and the Channel Islands. Why you would think that is a mystery to us. Up until last year, Profligate spent much of each summer on the hook at Harbor Reef just off the Isthmus. While the water at Catalina is a little cold after the tropics, the

hiking on the island is fabulous, as is exploring all the little coves in the dinghy. Weekdays were quiet enough to get lots of work done, either using a modem on the boat or the wi-fi in the restaurant garden patio area, which was very quiet in the afternoon. And it seemed as if you were a million miles from urban California. Thursday through Sunday afternoons were pleasantly crowded, with live music, dancing, sports on all the bar televisions, and all the BBQs blazing. Two Harbors is just fine with us, offering a whole lot of nature, with the basic conveniences — internet, showers, laundry, store, restaurant, bar, and BBQ pits. Avalon, about seven miles down the coast, is normally too touristy for our taste, but it's fun now and again, and it has a well-stocked grocery for a better selection than Two Harbors.

As for the other Channel Islands, the water may unfortunately be on the cold side, but there is so much to explore. Uninhabited Santa Cruz, for example, has 77 miles of pristine coastline waiting for surfers, divers, hikers, and nature lovers. There is no landing fee on any of these islands, except at the Nature Conservancy's 75% portion of Santa Cruz Island, which costs \$30 a boat per day or \$70 a year.

In a typical month, we receive a tremendous volume of letters. So if yours hasn't appeared, don't give up hope. We welcome all letters that are of interest to sailors. Please include your name, your boat's name, hailing port and, if possible, a way to contact you for clarifications. By far the best way to send letters is to email them to richard@latitude38.com. You can also mail them to 15 Locust, Mill Valley, CA, 94941, or fax them to (415) 383-5816.



WEBB LOGG

Hiking on uninhabited Santa Cruz Island is as good as it gets.

**Buy an Ullman
 Nylon or Dacron
 sail and get a
 FREE set of sheets***

**Contact your local Ullman loft today
 for details and a FREE quote.**



Newport Beach 714.432.1860	Marina del Rey 310.645.0196	San Francisco 415.332.4117	Arizona 602.499.3844
Long Beach 562.598.9441	Santa Barbara 805.965.4538	Ventura 805.644.9579	Santa Cruz 831.295.8290

** Sail must be constructed using Bainbridge Nylon or Dacron. Sheets will be for sail ordered, i.e. Jib sheets for a Jib, Spin for Spin, etc...*

HOME OF
ALAMEDA YACHT CLUB

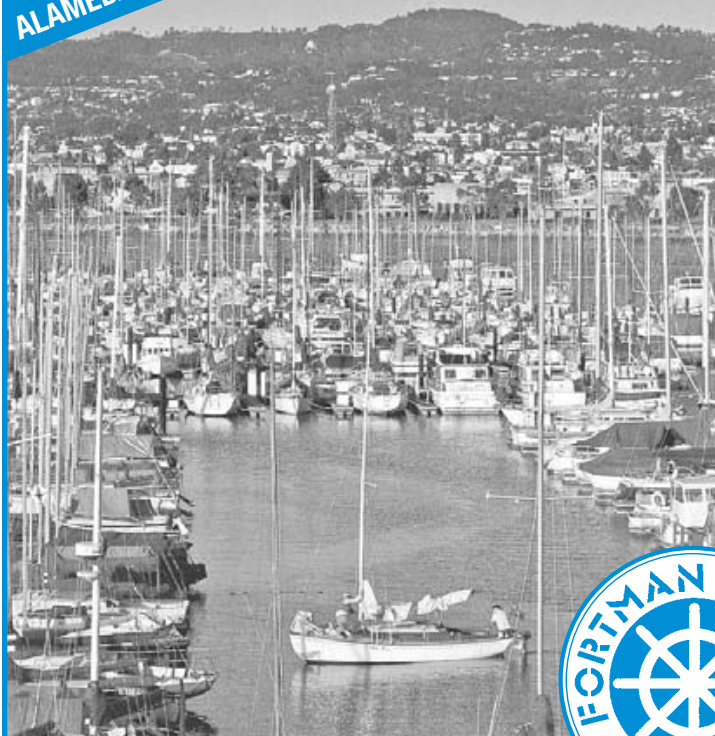

A quiet, well-protected cove with ample parking and amenities



'TIS THE SEASON (THE SAILING SEASON)

Come visit Fortman Marina this summer to find a new sailing home.

Covered Berth Available!

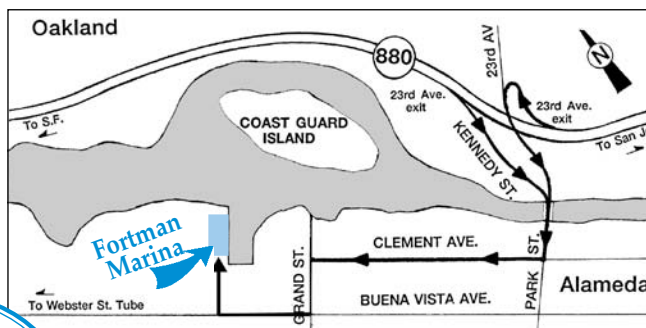

Considering a move?

Contact us for excellent rates:

(510) 522-9080

www.fortman.com

THIS YACHT MAINTAINED
BY:

Stem To Stern

FOR ALL CONCERNS, PLEASE CALL:

(510) 681-3831

Captain John* saw to my 48' Californian as if it was his own. He knows all the right people. He took my boat to the yard for a bottom coat and managed that project just like he manages engine maintenance, diving and deck cleaning at the dock. I call him for everything.

Frank Gallovich

*Captain John Curry is owner of **Stem to Stern**, a premier leader in boating services with trained instructors, licensed captains and insured service providers.

Our vendors provide services from general maintenance to major repairs so you can spend more time enjoying your boat.

Check out our website for a list of all our services at

www.StemtoSternSF.com

Or call (510) 681-3831

We Take the Work Out of Owning a Boat



Lowrie Yacht Harbor
INC.

In central Marin, convenient to Delta & Golden Gate

Family owned & operated since 1948

- **\$6.50** per foot – Best Rates this side of the Bay
- 25' - 65' Berths Available
- Surge and Wind Protected – Out of the Fog
- Convenient Location – Warm and Sunny
- Whole Foods & Trader Joe's Nearby
- Office Space Available

(415) 454-7595

40 Pt. San Pedro Rd., San Rafael, CA 94901

New Harbor Office Hours: M-F 9:30-4:30

coutts wads it up

The road to America's Cup 34 made its way through the Bay last month, and Oracle Racing CEO Russell Coutts found a pothole on June 13. Following a successful media outing which drew mainstream journalists from a plethora of outlets out for a spin on the Bay aboard the replica of the the first winner of the Auld Mug, the schooner *America*, the team got to work with race practice. As the journo's were packing up their gear and pulling out of the Golden Gate YC parking lot, Coutts and team skipper James Spithill went toe-to toe in their respective AC45s on a ripping, 25-plus-knot afternoon. During the pre-start of one of their scrimmages, Coutts went to bear away, hesitated, and tried again, sending the bows of his *Oracle 5* "down the mine" in a ball of spray.

In the pitchpole, Coutts was sent flying through the wingsail, and although it made for some good dramatic video and a long night for the boatbuilders, he was uninjured. The wing ribs, extremely light laminations of what appears to be a single layer of carbon fiber top and bottom with a Nomex core and exposed edges, were apparently no match for the world's most accomplished inshore sailor.

The boat was righted quickly and, by the next morning, the wing was repaired and *Oracle 5* was ready to go back out on the water. The capsizes followed on the heels of a near-miss the week before that was the closest thing we've ever seen to a capsize that wasn't. If nothing else, it illustrated Coutts' oft-repeated mantra that this Cup will be sailed by the best sailors in the world sailing the most challenging boats in the world. It left everyone wondering, "How are they going to do this in the AC 72s?"

If you missed Coutts' tumble (and near-tumble), you can find video on *YouTube*. Search for "Oracle Racing Team" and, for the near-miss, add "High Five!" For the full monty, look for "Oracle Racing capsizes." Both videos show just how wild the AC 45s are.

— rob

eight bells for rui luis

The Bay Area sailing community lost a well-loved and highly respected member on June 5. Rui Luis, the 48-year-old owner of Rooster Sails, fell into the water while trying to board his powerboat from his dinghy. "Rui had lost 100 lbs in the last year-and-a-half, and part

of his exercise program was to row to the Oakland farmer's market every Sunday," said close friend Jeff Berman.

Berman says a neighbor at Grand Marina saw Rui fall in and called for help to get him back on his boat. It appears he was in the water for just a few minutes, and when he was pulled aboard, was breathing and talking. But Berman says at some point 911 was called, and Rui was given CPR, put on a breathing bag and rushed to the hospital with a weak pulse. "I had

just arrived at the hospital when they told Ruthie [Rui's partner of 20 years] that he'd died," said Berman.

Although Rui was a longtime advertiser in *Latitude 38*, we didn't really get to know him until last month, when the publisher had him repair and recut some sails for the *La Gamelle* Syndicate's Olson 30. May he rest in peace.

— latitude 38

politics

In last month's *Sightings*, we reported that Washington State had banned copper bottom paint and California was close to passing a similar law in SB 623. The Recreational Boaters of California and Boat U.S. have loudly opposed the legislation. The RBOC inaccurately claimed in a widely distributed letter that boatowners would be required to spend \$5,000 every year to have a special non-toxic bottom coating applied, but later conceded that those numbers were inflated.

The reality of the bill was pretty mun-

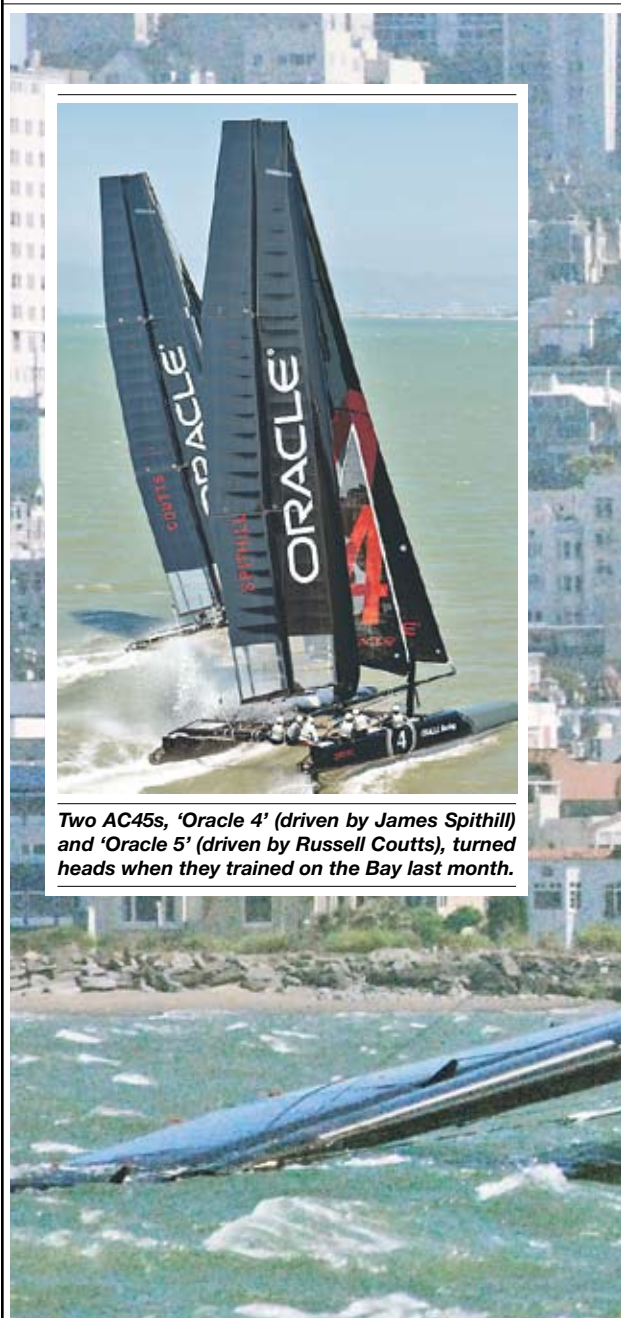

Two AC45s, 'Oracle 4' (driven by James Spithill) and 'Oracle 5' (driven by Russell Coutts), turned heads when they trained on the Bay last month.



The jovial Rui Luis of Rooster Sails in Alameda will be missed by many in the Bay Area sailing community.

JEFF BERMAN

as usual

dane: copper paints would be banned starting in 2019, giving boaters eight years to find an acceptable non-copper substitute. This shouldn't have been too troublesome since so many inexpensive and reasonably effective alternatives are already on the market, and more are released every year by paint companies who seem to understand which way the wind is blowing.

But California politics are never easy or simple. SB 623 passed the State Senate

continued in middle column of next sightings page

“honey, we have a problem”

It's not uncommon for sailors to arrive at their boat after a prolonged absence only to find a bird's nest tucked into the main — usually *after* raising the sail. But imagine being greeted by several thousand bees. That's just what happened last month at Vallejo YC when Dave Nadolne's Newport 30 *Windsome Winch* became the new royal digs for her majesty, Queen Bee.

When a swarm of bees attached itself to Nadolne's main on June 15, member Mary Kraybill knew just whom to call to take care of the situation: her sister, Benicia-based amateur apiarist Deborah Morrison. "I'm an avid gardener and already had two hives," says Morrison. "Now I have three!"

On June 17, Morrison and Kraybill suited up in beekeeping gear

continued on outside column of next sightings page

Yeowch! Russell Coutts' AC45 took a tumble last month and created a spectacle seen 'round the world.



A Coutts-shaped hole in the wingsail was quickly repaired.



SPREAD: TOM MACDONALD; INSETS: GUILAIN GRENIER / ORACLE RACING

SIGHTINGS

bees — cont'd

and began the painstaking process of gathering the swarm. "First, I sprayed them down with sugar water," explained Morrison. "They'd been there for a few days without eating because they were guarding their queen, so they were hungry — plus the sticky water weighs down their wings." When that was done, the sisters carefully swept the bees into a "Christmas ornament tub."

As Kraybill slowly unzipped the mainsail cover, Morrison realized that this job was going to be tricky. "I'm so lucky to have had a sailor to help me," she laughed. "I have no idea what I would have done because thousands of bees were glommed into each fold of the sail." Kraybill slowly raised the main as Morrison continued to sweep up the bees. There were so many, in fact, that they had to find another lidded container to collect them all. In the end, Morrison believes that

continued on outside column of next sightings page

politics

on June 2 and moved on to the Committee on Environmental Safety and Toxic Materials. On June 21, an amended version of the bill was released, and it bears almost no resemblance to its previous incarnation. As amended, the bill would allow the use of "low-leach" rate copper antifouling paints and would require the Department of Pesticide Regulation to "determine the maximum allowable leach rate" for such paints by January 1, '14. A year after that, all other copper paints would be banned.

"Low-leach rate" isn't defined in the



Sugar water helped soothe the estimated 10,000 bees that had crammed themselves in and around 'Windsome Wench's' main last month.



Not your average sailing outfit — Amateur apiarist Deborah Morrison suited up to collect a new hive.

PHOTOS MARY KRAYBILL

— cont'd

bill, but our assumption on reading it was that non-ablative/"hard" paints would be the likely choice. Don't count on it, says a source well-informed on the legislation. He says a paint's actual copper content, not the rate at which it leaches, will most likely be what the DPR looks at.

But the changes to the bill don't stop there. The biggest change — the one that made us think, "That has to be a typo!" — is the provision that if the State Water Resources Control Board determines that low-leach copper paints are still contrib-

continued in middle column of next sightings page



The queen, protected by her workers, was tucked inside the folds of the main. She was likely attracted to the blue sail cover.

bees — cont'd

the queen, who is only a little bigger than all the other bees and very difficult to spot, was among the 10,000 or so bees she collected. How does she know? "Because it's several days later and all the bees are still here," she said.

Morrison says the spring and early summer are when a new queen will go on a "mating flight." Her subjects follow her and when she picks a spot to call home, they surround her for protection and start building the combs into which she'll lay her eggs. But why on earth did she choose such a seemingly unlikely spot as a boat's mainsail cover? "Bees are attracted to the color blue — think lavender, asters, etc."



MARY KRAYBILL

Morrison says the swarm was tired and hungry from accompanying their queen on her mating flight, so they put up little resistance after being sprayed with sugar water (aka food).

Morrison said. "I think she saw the color blue and found the safest little place in the folds of the sail."

If you find your boat's main covered in bees in the spring or summer, you're most likely looking at the honey variety, as opposed to the Africanized 'killer' variety. Morrison suggests calling your local animal control office to see if they know of an apiarist who will come collect them. Not only has the honey bee population been mysteriously declining worldwide — and lord knows we need all the sweetness we can get in this world — but those bees will be none too happy to leave their queen unprotected. "Even though they were very unaggressive at this point and we were in protective gear," Morrison pointed out, "my sister and I each got stung."

— ladonna

pangaea inspires youth

Mike Horn's face doesn't have any scars, he's not missing any limbs, and he doesn't walk with a limp. Only with careful searching might one notice that the tip of his ring finger is missing — the only visible hint at his history of adventure, risk-taking, and daring exploration. Horn has been to places most of us only dream of, and is globally acknowledged as one of the world's greatest modern-day explorers.

Horn's newest adventure is aboard *Pangaea*, a 115-ft aluminum ketch he's taking on a four-year journey to visit youth across the globe. *Pangaea* will also serve as a platform to explore the natural world, learn about its challenges, find solutions, and act swiftly to make changes to safeguard the environment.

On its way north from L.A. at the end of May, *Pangaea* stopped on the Bay for a visit before heading to Vancouver and, ultimately, the Northwest Passage. OCSC's Anthony Sandberg organized a meet-and-greet with Horn and his crew of two, and I was lucky enough to be invited. As a 19-year-old "youth," I'm concerned for my tomorrow, and was quite impressed with *Pangaea* and Horn's plans for her.

At the beginning of our afternoon, a group of young people, as well as a number of adults, were regaled with stories from Horn's previous expeditions. Originally from South Africa, Horn moved to Switzerland and opened an outdoor activity center in '95. In '97, he completed his first major expedition in which he navigated the entire length of the

continued on outside column of next sightings page

SIGHTINGS

pangaea — cont'd

Amazon River alone and without motorized aid. Two years after that, he circumnavigated the globe along the equator, either on foot or on an engineless 28-ft trimaran. (It was while preparing for that expedition that Horn was introduced to the world of sailing.) He went on to solo circumnavigate the Arctic circle, travel to the North Pole during the permanent darkness of the winter months, and climb peaks higher than 26,000 feet without the aid of additional oxygen.

Horn's newest projects — *Pangaea* Expedition and the Young Explorers Program — aren't

physical mountains but they present new challenges to tackle. *Pangaea* set sail from Argentina in '08, and has since visited ports around the globe, inviting youth onboard to learn, grow and be inspired.

Our sail on the Bay was a pretty straightforward reach from San Francisco to Richmond and back. I was very impressed by the scale of everything. Even though

we all took turns raising the sails, everyone was huffing and puffing by the time they were fully up. When I took my turn at the wheel, I was surprised by the number of times I had to turn it to feel a response. But the best part of the day was having time to chat with Horn one-on-one.

He explained that the Young Explorers Program (YEP) takes young adults on smaller versions of his other adventures. These expeditions use nature as a resource to increase understanding of environmental issues. By fostering an appreciation for the natural world, the program catalyzes youth into action. If Horn can show young adults the inextricable link between living and the earth, then maybe there is a brighter future ahead, a future in which humans learn to care for our Mother Earth.

Horn spoke of why he does it: to feel alive, to feel utterly awake in his body. As my sister, Hannah, simply put it: "You can't care for something you don't love." In this spirit, young people between the ages of 15 and 20 who are "adventurous, keen to explore, and inspired to make a difference" can apply online at www.mikehorn.com for a selection camp where, after 10 days of training, eight candidates are chosen for an expedition. This fall's trip to Nunavut, Canada, is already full, but more are coming up. The YEP program, which is funded by Mercedes-Benz, is so fascinating that I'm seriously considering applying.

Mike Horn's maxim states: "The impossible exists only until we find a way to make it possible." I believe that, for all of us onboard that day, our eyes were opened to new possibilities and we have newfound hope for a better future — with today's youth at the helm.

— sarah arndt

hee-hee and ha-ha

Chico YC recently completed its 6th annual Lake Oroville Hee-Hee. That the name of this cruise resembles another, more famous cruiser's rally is no mistake. The Baja Ha-Ha was the original inspiration but that's where the comparison ends.

Lake Oroville was created in the '60s as the cornerstone to the California Water Project. The 770-ft-high earthen dam is the second

continued on outside column of next sightings page

politics

uting to poor water quality — how they would be able to distinguish between copper from bottom paint and copper from brake pads is anyone's guess — all antifouling paints would be banned. Yes, you read that correctly. All.

"117146 (b): On or after January 1, 2019, if the State Water Resources Control Board does not demonstrate that the trend line of the measured water quality data points toward attainment of the dissolved copper water quality objectives in California marinas and harbors, then *the use or application of antifouling paint*

LATITUDE / JOHN A.



Sarah (left) and Hannah Arndt flank world-renowned adventurer Mike Horn during a recent Bay Area visit.



We totally agree with this gal's reaction to sailing on San Francisco Bay.



Grind it, girls! Young people experience firsthand what's involved in sailing such a big boat.

— cont'd

on recreational vessels shall be prohibited one year after the determination.”

We're assured by our source that the word "copper" probably wasn't left out accidentally — all bottom paints would be banned, and boaters would be required under the law to remove the paint on their boats. Not only would that be ridiculously expensive for boaters, but it would also be completely unenforceable. And let's not even discuss where all that ground-off copper paint would go, because we all know an obscene amount would end up

continued in middle column of next sightings page

hee-hee — cont'd

largest in the world and is built below the confluence of the three forks of the mighty Feather River, which drains nearly 4,000 sq miles of the northern Sierra Nevada and southern Cascade Mt. Lassen. It holds nearly 3.5 million acre feet of water and has 167 miles of shoreline. Besides providing flood control, electricity, and water for rice and other ag lands, it's a top attraction for fishing and boaters in the state.

The original concept for the Hee-Hee was to spend a week circumnavigating the South, Middle, and North Forks, as well as the west branch of the Feather River by sailing when we could, motoring when we had to, and anchoring overnight before happy hour and lighting the BBQs. After about a week of making our way up the long steep fjords, we finished up by renting a floating campground on the last weekend. Floating campgrounds are very cool two-story aluminum

continued on outside column of next sightings page



Adventurer Mike Horn's 'Pangaea' is the generously-sponsored platform from which he hopes to inspire and educate.

SPREAD: DMITRY SHAROMOV/MIKE HORN; INSETS: LATITUDE / JOHN A.

SIGHTINGS

hee-hee — cont'd

structures anchored around the lake — folks can pitch a tent on top, raft up, and celebrate the end of the Hee-Hee with a party. The campgrounds come with a galley, head, and BBQ, and rent for a very reasonable \$150 per night.

This year we had an abundance of water so passing beneath the two bridges was handled with caution. High water made it possible to go all the way up the Middle Fork and view Feather Falls — at over 400 feet, it's the fourth tallest in the state. We also cruised up the South Fork to Ponderosa Dam before rafting up for the evening.

During the raft up on the floating campground, we welcomed three new boats to the club and hosted a total of nine boats ranging from a Lido14 to an Islander 36. All told, 25 CYCers enjoyed celebrating the end to another successful Oroville Hee-Hee. Maybe one day the Hee-Hee will be as big as the Ha-Ha — but, considering the size of the floating campgrounds, we hope not!

— herb clark

imagine, catalina 270 / hotel charlie, catalina 25

politics

right back in our waters, doing far more harm than if it'd just stayed on the bottom of our boats.

Talk about throwing the baby out with the bath water!

So why on earth did the bill get changed so drastically? Our source suspects the RBOC had a heavy hand in sabotaging this latest draft, submitting wording in such a way that essentially makes it a lame duck law because of its unenforceability. The state can't afford to keep DMV open five days a week, much less hire someone to go check every boat for copper bottom paint. Either that, or the environmental lobby pushing the bill through is completely out of touch with

PHOTOS HERB CLARK EXCEPT AS NOTED



They're coming to take me away, Hee-Hee, Ha-Ha! Chico YC's Ha-Ha-inspired Hee-Hee was crazy — (clockwise from above) 400-ft Feather Falls was a hot attraction, as was Ponderosa Dam; floating campgrounds can be rented for \$150/night and can accommodate several boats; easy breezy spinny sailing on Lake Oroville; snuggled up.

PAT EDIGER



— cont'd

reality.

Interestingly enough, the RBOC seems much more satisfied with this new version of SB 623 — though they wrongly state on their website that only “copper paint” could be banned in '19 — which might lead someone to agree with our source's first suggestion.

Regardless, we're sad to say that what had been a promising piece of legislation is now one of the more ridiculous boating-related bills we've seen in a while. No matter which side of the fence you stand on, it's a lose-lose, and a complete waste of the legislature's valuable time.

And don't be surprised when it passes.

— *ladonna*



VIC MAKAU

budgeting aboard *carmen miranda*

Cindy Holmes and partner Faith Tamarin of the Berkeley-based Vanguard 32 *Carmen Miranda* are just a Baja Bash away from completing a 12-year circumnavigation, and they have three major pieces of advice for women based on their experience:

1) “Via a cruising boat is the only way for women with no real money to be able to see all the things they want to see in the world.”

2) “For women — and men — to be confident and relaxed while cruising, they need to know how things work, and to be full partners in the sailing and maintenance of the boat. Between us, Faith and I can fix anything, except for things that need to be sewn or welded.”

3) “Two women can cruise the world on \$500-600 a month. We don't know anybody who cruised on less money than we did.”

And lest any women think that age is any more of a barrier than gender is, Cindy is 55 and Faith is 70.

It's important to note that the duo's circumnavigation did not involve denying themselves any important experiences. Prior to starting, they got out a globe and put red dots on all the places they wanted to go and things they wanted to do, no matter if it was seeing the Komodo dragons of Indonesia, the orangutans of Borneo, or the pyramids of Egypt; climbing to the top of St. Peter's in Rome; transiting 265 locks in Europe; or even living the lives of London train commuters.

Faith has been a long time sailor and boatworker, having been a delivery skipper, the captain of an S&S 65 on the Bay, a rigger at the top of masts, and a varnisher. It's Cindy, however, who has the greater experience and skills with mechanical things. In fact, she's had a career at UC Berkeley setting up physics experiments for professors to run in front of 500 students.

Cindy got into boats because she couldn't find an economical place to live in Berkeley. She started with an old landing craft she bought from the Sea Scouts that she turned into Cleopatra's Barge, but soured on how much it cost to fill up the fuel tanks, and how smoky and noisy it was. Having become friends with sailors in the marina, she moved to a Triton 28, and for the cruise with Faith, the Triton's big sister, a rugged Vanguard 32, which she says has been a great boat.

So when it came to replacing *Carmen Miranda's* Atomic 4 engine with a Kubota diesel, Cindy did all the work. In fact, she's rebuilt the undersized original and replacement Hurst transmissions for the diesel four times, and can now do it in the boat's galley in one afternoon while on the hook.

It troubles Cindy that more cruisers — particularly women — aren't very knowledgeable about mechanical and sailing issues. “I've seen lots of couples have problems or split up in large part because they were always having to wait for very expensive mechanics to do even simple jobs on their boats, or because they didn't understand the basics.”

Cindy and Faith's circumnavigation was unusual in a couple of respects. First of all, they sailed all the way to Greece, 80% of a circumnavigation, in the first three years. But then, at a place where many West Coast circumnavigators make a mad dash for home, they started to really settle in. They returned to Northern California to work, and used the boat as their summer home in the Med. “When we kept the boat at Fiumicino Marina, which is just down the Tiber River from Rome, we'd take the train into Rome each day — it wasn't expensive — and then just walk around that fabulous city until we were exhausted. I can't tell you how many pairs of shoes we wore out.”

After about five years of that, they lowered their mast and set it on

continued on outside column of next sightings page



Cindy Holmes and Faith Tamarin (not shown) are close to finishing a circumnavigation.

COURTESY CARMEN MIRANDA

budgeting — cont'd

deck, then traveled the Rhone and other rivers and canals to Arles, Avignon, Lyon, Paris, and ultimately Amsterdam. You know the Arsenal Marina; less than half a mile from Notre Dame in the heart of Paris? Cindy and Faith lived on their boat there for a month for \$25/night.

They kept the boat in Ipswich, England, for two years, and used her as an inexpensive hotel for for countless 90-mile train trips to London and to explore the rest of England. From there they did a conventional trip down to the Canaries, across the Atlantic, through the Canal — with an all-women transit crew — and up toward California.

Faith and Cindy are poster women for world cruising not having to cost that much. "We took off for the South Pacific with \$500. The keys to being able to survive on a low budget are being able to do everything ourselves, not drinking, not smoking, and not staying in a marina for the first three years." After the first three years, they returned to the Bay Area to work, except for the summers, and they also found boat and furniture work in Australia and in Israel.

If the non-drinking and non-smoking duo sound like they don't have a vice, they do: "It's what the Aussies called 'bikkies' or biscuits, or what we Americans call cookies. In every country we were quick to try the local versions." And for vegetarians, Cindy says they ate as poorly as teenagers. "We like our food quick and easy. When we arrived in the Marquesas, we were delighted to find Lady Lee frozen vegetables, just like here in the Bay Area. We also eat a lot of cous cous, because it doesn't require much water, and it only takes a few minutes to prepare. But France was the best for eating. We'd go to the local *patisserie* and get a nine-inch lobster quiche for four euros!"

— richard

the joys of fishing naked

When you're out cruising, laundry facilities can be hard to find. The chore of doing laundry in a bucket is so dreaded aboard our Seattle-based Chris White Atlantic 42 *LightSpeed* that clothes pile up for a month or more at a time. If it's warm out, and there's no one around to impose upon, why not take off the clothes and save yourself from adding to the laundry pile? This is an especially good idea when fishing because few things smell worse than month-old dead fish.

But this article isn't really about cleaning a fish naked. It's about how to catch, clean and prep a 'naked fish' — in other words, to make it sushi grade. The proper technique is called *Ike Jime* and is a bit detailed but, with practice, can be very quick and makes for superb eating. Prepared using this method, fish are firmer, not mushy or smelly, and will last longer.

When fish run amok, get smashed on the head and flop around the deck, lactic acid builds up in their flesh, so it's critical to dispatch the fish as quickly as possible. As soon as you get the fish close to the boat, find the soft spot between and just just behind the eyes and, using an ice pick or similar tool, 'spike' the brain. This is the quickest and most humane way to kill the fish.

Once the fish is spiked, insert a length of thick monofilament or wire (I always have a piece of weed whacker line tied to my stern step for easy access) in the spike hole and run it down the spinal column. This will completely sever the spinal cord, and the fish will instantly stop tensing and thrashing.

It's essential to bleed out a fish before you gut it. There are several schools of thought on the subject, but my preference is to sever the gill cage by simply reaching in and ripping out the gills with my fingers. You can also cut the gill arch, the soft area just below the gills. Lift the gill cover and cut the arch where the soft membrane meets the rough skin. Some people prefer to cut below the pectoral fin across the lateral line, but if the cut is too deep, it can really chop up a good portion of the filet. Be sure to also put two small cuts on either side

continued on outside column of next sightings page

2010 uscg

Last month, the U.S. Coast Guard released their 2010 recreational boating stats, always an illuminating read. For example, take a guess which month had the highest percentage of fatal accidents. Did you say July or August? You'd be wrong. According to the report, March, February and November had the highest percentages of fatal accidents — 26%, 25% and 22% respectively — while June through August had the lowest at 9% each. Ironically, July had the second highest number of fatalities, 118, but it also had the highest number of non-fatal accidents at 1,023.



Sushi anyone? Kathy shows you how to prepare 'naked fish' naked. She and husband David have sailed 55,000 miles on 'LightSpeed' and are currently working their way up the Inside Passage to Alaska. We have no doubt Kathy will put her fish cleaning skills to good use, though we guess she'll be wearing more clothes!

boating stats

But most of the statistics in the report were fairly unsurprising: Nearly half of the 672 fatal accidents last year occurred on open motorboats (325) — sailboats had only 23 — and boats that were under 26 feet (584); drowning was the most common cause of death (484; 395 of them were not wearing PFDs) and alcohol use was the most common contributing factor in fatal accidents (126); and 84% of all fatal accidents happened on boats operated by someone who had received no boating instruction.

Here are a few highlights from the
continued in middle column of next sightings page

naked — cont'd

of the tail across the lateral line.

Choose the method you prefer, then loop a small line through the jaw with a bowline and attach it to the boat. Drop the fish in the water and let it drag for about 10 minutes (it's best to keep the boat's speed to under seven knots for this part). This will expedite the bleeding out and will also help cool down the fish.

To make gutting simple, I cut the gills all the way around where they attach near the head, then I cut out the anal opening. If done correctly, it's an easy trick to just grab hold of the gills and pull the entire innards out in one piece. Rinse the fish in the seawater and prepare to filet or chill.

Ideally, the fish would be packed with ice to chill it, but I usually filet it before I cool it down since I'm already dirty and all the gear is out — plus my fridge can't accommodate an entire fish. Everyone

continued on outside column of next sightings page



PHOTOS COURTESY LIGHTSPEED

SIGHTINGS

naked — cont'd

has their own filleting techniques, and mine are always evolving, so I'll leave it to the reader to develop his or her preferred method.

Before packaging the fish, sop up any liquids with a paper towel. The goal is to cool the fish down quickly, so avoid packing a bunch of filets in a large Tupperware or ZipLoc. Instead, wrap each piece in plastic wrap and put the pieces in the coolest part of the fridge. When you are ready to eat, they will be cleaned, skinned, bled and ready to serve.

While cruising the South Pacific, we just had to drop a line behind the boat and fresh fish — tuna, mahi, wahoo and so on — was on the menu. My husband, David, doesn't like fish too raw, so I often sear it quickly on each side in a hot cast iron pan and serve it up with some wasabi and fresh ginger. For that, I highly recommend a full-size apron to prevent splatter burns!

— *kathy kane*

stats

executive summary of the report:

"In 2010, the Coast Guard counted 4604 accidents that involved 672 deaths, 3153 injuries and approximately \$35.5 million dollars of damage to property as a result of recreational boating accidents.

- The fatality rate was 5.4 deaths per 100,000 registered recreational vessels. This rate represents a 6.9% decrease from last year's fatality rate of 5.8 deaths per 100,000 registered recreational vessels.
- Compared to '09, the number of accidents decreased by 2.66%, the number of deaths decreased by 8.70% and the



'Mimicat' was on the prowl.

Looking Good — 'Raven' may sport a Brooklyn, NY 'tramp stamp' but we're guessing she perches somewhere on the Bay.



— cont'd

number of injuries decreased by 6.10%.

- Almost three-fourths of all fatal boating accident victims drowned, and of those, 88% were not reported as wearing a life jacket.
- Eight out of every 10 boaters who drowned were using vessels less than 21 feet in length.
- Alcohol use is the leading contributing factor in fatal boating accidents; it was listed as the leading factor in 19% of the deaths.
- Twenty-one children under age 13 lost

continued in middle column of next sightings page

catch a ride on the ha-ha

With nearly 100 boats already signed up for this fall's Baja Ha-Ha Rally, there's a lot of excited chatter among soon-to-be cruisers in marinas all along the West Coast. If that's making you feel sadly left out because you're not ready to make the southbound pilgrimage to Cabo in your own boat this year, we've got a suggestion for you. Try catching a ride aboard someone else's boat — perhaps even someone you've never met. How? Check out the Mexico-Only section of our online Crew List at www.latitude38.com. There you'll find a bunch of skippers looking for able-bodied watchstanders for the 750-mile rally. The list is accessible 24/7



COURTESY JENNIFER

Lars Hassler is sailing 'Jennifer' 4,800 miles from Japan to join the Ha-Ha.

and is constantly evolving, so who knows? An ideal ride to the sunny latitudes of Mexico might be just a few mouse clicks away.

This year's rally starts on October 24, with the deadline for entries September 10. As you'll see by the latest entries below, boat types and homeports are as varied as ever.

— andy

Additional entries as of June 24:

- 75) **Jennifer**, Beneteau Oceanis 500, Lars Hässler, Stockholm, Sweden
- 76) **Knuckle Dragger**, Hunter 38, Robert Craig, Portland, OR
- 77) **Arctic Tern 111**, Nordic 40, John Garteiz, Whittier, AK
- 78) **Realtime**, Norseman 447, Bob & Karyn Packard, Long Beach
- 79) **Azure-Té**, Ron Holland 43, Jack Gill, Sausalito
- 80) **Buena Vida**, Catalina 42, Jeff & Julie Leonard, Ventura
- 81) **Sojourn**, Pearson Alber 35, Bridget & Bruce Eastman, Brisbane
- 82) **Outrageous**, Hunter Legend 45, Ray & Dori McEaney, Vallejo
- 83) **Murar's Dream**, Beneteau 46, Andrew Rosen, Marina del Rey
- 84) **Tranquilo**, Catalina 400, Lloyd & Colleen Clauss, San Pedro
- 85) **Sundance**, Beneteau M38, Rick Donker & David Rempel, San Francisco
- 86) **Tara**, Caliber 28, John Neeley & Shannon Walker, Berkeley
- 87) **Nirvana**, Irwin 45, Bob & Sherry Davis, Shell Beach
- 88) **Sailpotion**, CSK 40, Herschel & Susan Pence, Vallejo
- 89) **Orion**, Hunter 466, Connor Lamm & Yvonne Sininger, Marina del Rey
- 90) **Caledonia II**, Jeanneau 452, Ed Fudge & Peter Ruben, Calgary, AB
- 91) **Tan Tori**, Island Packet 445, Roger & Tori Robinett, Seattle, WA



The crew were smiling aboard 'Bandaloop'.

the bride wore blue socks & top-siders

As the steward for the La Gamelle Syndicate's Olson 30 *La Gamelle*, which is currently berthed at Marina Village in Alameda, we've suddenly gained a whole new group of sailing friends in that part of the world. Among them are David and Elena Esser of the new Prout 50 catamaran *Tigress*, with which *La Gamelle* shares an end-tie.

We first met David last month by saying, "We're glad you have that inflatable hanging down from the back of your cat, because we took the engine off the Olson, so we plan on docking by sailing the bow of our Olson into your inflatable at a 90-degree angle, which will carom our boat right into her spot on the dock."

"That will be fine," David replied. "By the way," he continued, "Elena and I are getting married next Saturday, and are having the reception aboard. You should come." So we did.

Everyone was given bright blue boat socks, and Elena proudly wore hers with her TopSiders. We think it's a pretty saucy look. Her socks were monogrammed with the date of June of '10, because that's when their boat was scheduled to be launched and they were to be married. Since the boat was a year late in being delivered, they obviously had to postpone the wedding by a year, too.

People say that the 'apple never falls far from the tree', but only

continued on outside column of next sightings page



'Mary Ann II' struts her stuff.

SIGHTINGS

blue socks — cont'd

people who don't live on hillsides. You see, David is the son of admitted 'hippie vagabonds', who 35 years ago would buy one-way tickets to the far corners of the world and drag him along. Instead of following in the footsteps of the parents, David has thrown himself into the internet world, and apparently has been successful at starting several companies. The big cat is his move away from life being all about work.

David has also been successful in gradually introducing Elena to the water and sailing. He had to start with the ultra basics because in the beginning Elena was so afraid of the water that she wouldn't even walk down a dock. But now she's happily living aboard, and looking forward to the mast being stepped in a few weeks.

Tigress is actually the couple's second sailboat. They also have an exact sistership to Lin and Larry Pardey's 29-ft wood *Taleisin*, right down to the bathtub. If you're looking for a boat like that, you know who to contact.

Anyway, we'd like all of you to join us in congratulating our new good friends David and Elena on their marriage — and on their new catamaran.

— richard



LATITUDE / RICHARD

The groom and bride aboard their luxurious new Prout 50 catamaran, 'Tigress'.

pass the falafel

Despite recent regime changes and revolutions in nearly every surrounding country, Israel has not only remained intact, but was recently voted the "ninth happiest country in the world" by a Paris-based nonprofit research center. Countries were ranked by employment, health care and quality of life. Israel beat out Austria, and was right up there with Norway, Switzerland, Denmark, and Canada. The U.S. didn't even place in the top 10.

We like to think part of that satisfaction may come from sailing. Israel's 170-mile-long coast boasts eight major marinas, with most being full. Interestingly, sailboats outnumber powerboats by a large margin — 9-to-1, it seemed to us. With beautiful Mediterranean waters, balmy air and abundant sunshine, it's a sailor's paradise. Its proximity to Turkey, Greece, and Cyprus — just a daysail away — is the proverbial 'icing on the cake'.

On a recent visit to Israel, my wife Miri and I met our long-time friend and Israeli sailor Iris Katz, who arranged a day trip with some local sailors. We'd sailed with Iris to Cyprus, Turkey, and Greece in '91 on her Beneteau Evasion 28 *Meitalon* and since then she's become one of Israel's preeminent skippers for deliveries, rallies, and instruction.

We met Iris at Tel Aviv Marina, which has been expanded and considerably improved since our last visit there. It even features a large lap pool, rental bikes for "green" excursions, and new modern docks and facilities.

Iris introduced us to her friend Rafi Israel, a local businessman and long-time sailor. Rafi bought his Hunter 41, *Carioca*, new in '04, graduating from a Catalina 30. Hunters are very popular boats in Israel, as are Beneteaus, Jeanneaus, Bavarias and most other European boats.

continued on outside column of next sightings page

stats

their lives while boating in '10. 42% of them died from drowning. 44% of those who drowned were wearing a life jacket.

• The most common types of vessels involved in reported accidents were open motorboats (46%), personal watercraft (20%), and cabin motorboats (14%)."

Interestingly, though only 23 people died on sailboats last year, while 380 died on powerboats, the numbers suggest that sailboats are less safe than powerboats. As reader Steve Hodges, who sails his Islander 36 *Frolic* out of Santa Barbara,



L'chaim! — (clockwise from above) Sausalito's John and Miri Skoriak enjoyed falafel in Israel last month aboard a new friend's Hunter 41; 'green' rental bikes ready to ride at the Tel Aviv Marina, where Med-style mooring is practiced; local shops offer a wide and beautiful variety of food; "Where's the hummus?"; just in case sailing isn't enough exercise — or you simply want to lounge — the marina also boasts a luxurious new lap pool.



— cont'd

points out, “The death rate for all powerboats is about 33 deaths per million boats, but the death rate for sailboats is about 58 per million, so it seems sailors have almost twice as high a death rate *per boat* as powerboaters.”

This seems to go against common sense, but the numbers don't lie. Steve theorizes that sailboats are used more frequently, and that the “death rate per hours of operation” for sailboats would be much lower. Let's hope so!

— *ladonna*

falafel — cont'd

As one would expect with a late-model boat, *Carioca* was immaculate, well-equipped and comfortable. Rafi was joined by his “Friday sail” friends — they sail every Friday from spring to late fall, and often sail to Turkey or Greece for several weeks.

Soon after leaving the dock and sailing out the breakwater we were gliding along at about 5-6 knots in 10 knots of wind. Coming from San Francisco Bay, we forgot how pleasant sailing could be — some might even call it “zen.” We had plenty of shade for the mid-80s temperatures, and lots of fresh Middle Eastern food on board — fresh falafel, hummus, fresh baked pita bread, etc. Sailing doesn't get much better than that, and despite living in a ‘rough neighborhood’, Israelis take advantage of it every chance they get.

— *john skoriak*

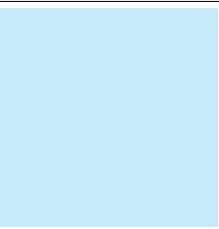

PHOTOS JOHN SKORIAK



SALT

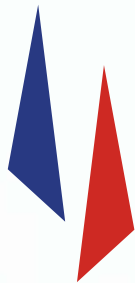

CLIPPER
YACHT HARBOR

You want complete and uncompromising marina services? Done. Hauling, maintenance, easy access parking, launch ramp, onsite security, and wifi? Covered. Have a wish list that includes clean, warm, newly remodeled restrooms and laundry facilities, dock carts, convenient recycle and garbage bins, and dedicated dry boat storage? Handled. So whether you're on the water, in the slip, checking in, hanging out, or pushing off, we have you in mind. 310 Harbor Drive Sausalito, CA 94965 415.332.3500 clipperyacht.com

AMERICA'S CUP 34



Oracle Racing and ACRM knocked it out of the park last month with their visit to the Bay. Perhaps sensing the need to keep local interest in AC 34 stoked, they brought a pair of AC 45s in early June, and left having given the event's profile a serious boost.

Of course Russell Coutts' "pitchpole heard 'round the world" (see this month's *Sightings* on p. 72), which even drew coverage from the gamut of mainstream media, was obviously the crossover highlight of the trip. But it was hardly representative of what the team and ACRM accomplished here.

Starting with a design briefing on June 13 attended by just about every media outlet but Univision and Telemundo — who knows, they might have been there too, but it was so packed it was impossible to tell — the event rolled right into a day trip on the Bay aboard the replica *America*, for everyone from the journalists to mayor

AC45s and a typical June day on the Bay — Blam!

Ed Lee on what was probably their first sailing experience, with the AC 45s buzzing by at 20-plus knots.

Of course the pitchpole didn't happen until after the media hit the dock that day, but many saw it as they left the Golden Gate YC parking lot, and the result was that it garnered a bunch of attention that the day might not otherwise have.

The rest of the week was devoted to media trips aboard the AC 45s for a few lucky journalists, as well as a VIP day rumored to bring out people like Governor Jerry Brown, Lt. Governor Gavin Newsom, and confirmed to have drawn Grateful Dead drummer Mickey Hart. Media weren't exactly invited to those — unfortunately — but it was another fruitful step in the "blocking and tackling" of the PR campaign that ACRM, the ACEA and Oracle are waging. But those weren't the only battles on that front during the week

The Challengers

On June 15 ACEA announced the team slate for the 34th America's Cup, and anyone hoping

for a surprise was probably disappointed. Only one of the "undisclosed" teams — Spain's Green Comm Challenge, not announced until June 23 — was able to cross the threshold into becoming an America's Cup challenger, so the lineup is pretty much unchanged from what's already been announced.

Challenger of Record Artemis Racing was joined on the Ferry Building's mezzanine by China Team, Aleph Equipe de France, Emirates Team New Zealand, Vene-



GILLES MARTIN-RAGET

Mickey Hart

— SAN FRANCISCO BAY

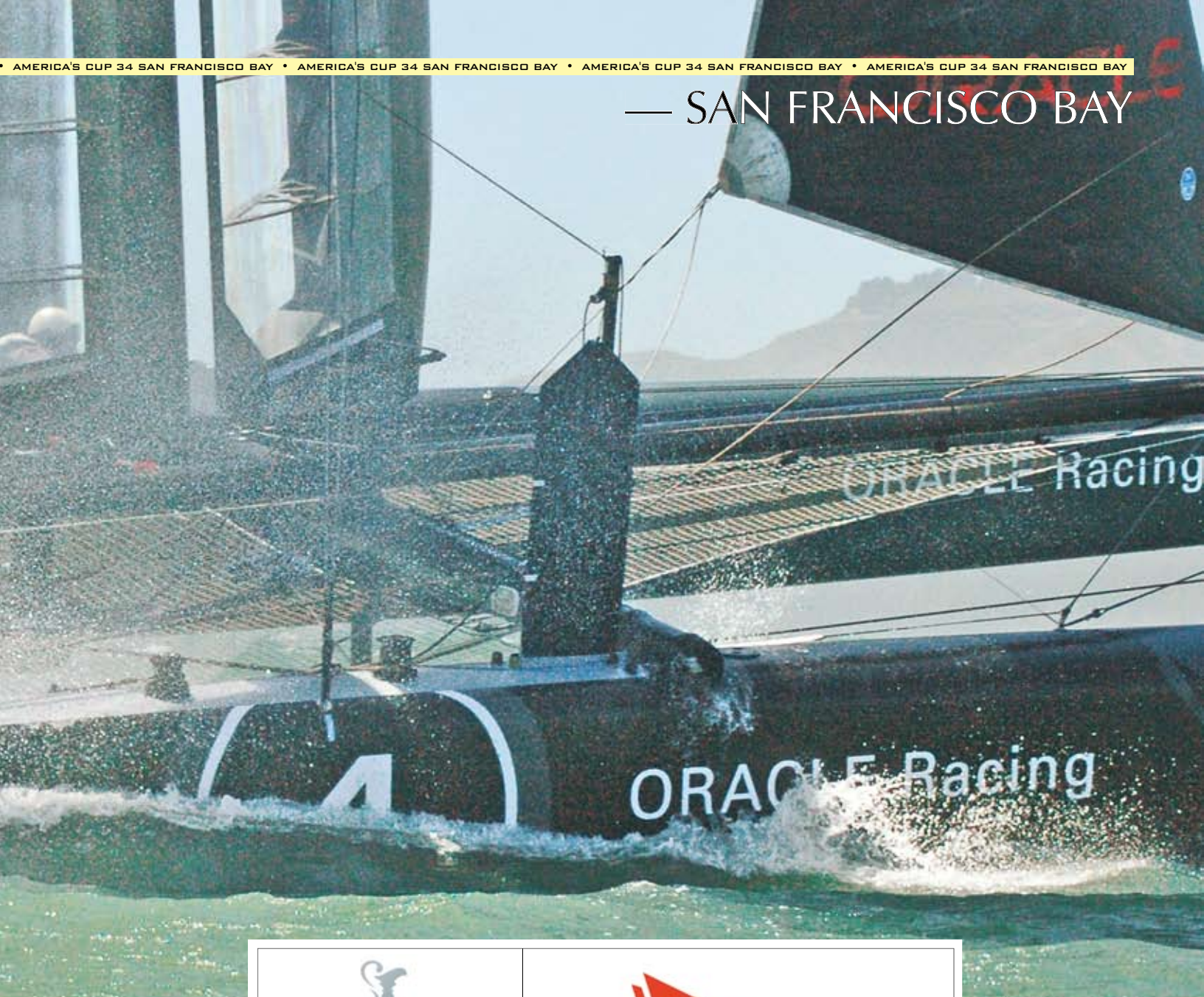

zia Challenge, Energy Team and Team Korea — a total of eight teams (including Green Comm).

Although ACRM was undoubtedly looking for more challengers, the provincialists out there who've been hoping that the 34th Cup would fall flat must be disappointed. The participation of both China and Korea should prove to be a huge boost to the Cup's commercial viability.

There were some other key announcements at the press conference, notably that the 136 containers required to transport the America's Cup World Series road show around the globe will make their way to San Diego November 12-20 after stopping in Cascais, Portugal, August

SPREAD LATITUDE/ROB



The new America's Cup and Louis Vuitton Cup logos are decidedly less exciting than the AC 45s.

6-14 and Plymouth, England, September 10-18.

Our Ride on an AC 45

After a week of non-stop media and VIP outreach, Oracle Racing turned its attention to race practice for the first AC World Series in August. *Latitude 38* Associate Publisher John Arndt and this editor were invited to experience the AC45s on June 21, and although the mini heatwave

we'd been having left us wondering whether there'd be any breeze, by the time we were drove over the Golden Gate Bridge on the way to the team's base at Pier 80, the Slot was already starting to

breathe.

We got to the base in time to see *Oracle 4* and *Oracle 5* wheeled out of the shed, have their wings raised and the whole package launched, ready to go, in what couldn't have been more than 20 minutes per boat. Rows of shipping containers, Jet Skis and chase boats lined the dark, massive shed that houses the team's local operations, not to mention the wing from USA 17. If working for a Cup team is all glitz and glamour, you wouldn't know it by seeing this temporary base.

AMERICA'S CUP 34

The team's clothing and equipment container served as our changing room, and we managed to get out of there having resisted the temptation to nick an Oracle Racing belt or switch out all the gear in the box marked "L. Ellison" for extra-smalls of everything.

Because the team was on a tight schedule to get their practice going, we knew from the outset that our time on board would be limited. ACRM would be out there testing all the regatta systems, and you just can't keep helicopters waiting indefinitely. So, instead of jumping on from a chase boat, we were able to leave the dock on board — Arndt with the 'Facebookers' aboard James Spithill's *Oracle 4*, and this editor aboard Russell Coutts' *Oracle 5* with the 'Flintstoners'. As we were preparing to shove off, word came down that Russell was stuck in a conference call and



GILLES MARTIN-PAGE

Representatives from the challengers joined San Francisco Mayor Ed Lee on stage on June 15 for the announcement of the challenger slate.

wouldn't be joining the boat until later. So Aussie Darren Bundock — a double Olympic silver medallist in the Tornado and three time F-18 world champion — took over as helmsman. A couple former Alinghi/Team New Zealand sailors — and four-time Cup winners — Murray Jones and Simon Daubney, rounded out the

crew on *Oracle 5*, along with Volvo Ocean Race and AC veterans Matt Mason and Simeon Tienpont.

Leaving the dock in the small turning basin next to the shed, the boat instantly leapt forward, attaining a low hum as Bundock bore away down the channel toward the Bay. After having to take a tow

up to Pier 17 where we finally found the breeze, the crew got to work, settling in for a long beat. The guest spot on an AC45 is behind the aft crossbeam where there are a couple "oh shit" handles between the running backstay blocks. We nervously inquired about the loads on the runners, as this editor is generally averse to putting his head, or any part of his body, near a highly loaded running backstay block. Jones told us that there's a load pin on one end of the cable that runs from the prod to the dolphin striker and underneath the

Discover
Brisbane Marina

GREAT LOCATION! Just minutes to Central Bay sailing.
GREAT RATES! Starting at \$5.90/foot!
MARINA GREEN with picnic/BBQ areas, Bay Trail Access and FREE Wi-Fi.
HOME OF THE SIERRA POINT YACHT CLUB



From Hwy 101, take the Sierra Point Pkwy exit and follow the signs to the marina.

400 Sierra Point Parkway
Brisbane, CA 94005

www.ci.brisbane.ca.us

(650) 583-6975

harbormaster@ci.brisbane.ca.us



— SAN FRANCISCO BAY

tramp back to the aft crossbeam. They're winding 11.5 tons on that cable via the runner, although the loads on the runner are much lighter.

As we matched up side-by-side, we could almost hear Bundock thinking, "Why did I get the 105-kilo guy and Spithill get the 75-kilo guy?" as this editor's contribution to (at that point, undesirable) transom immersion allowed *Oracle 4* to shear off us as we trucked upwind in the low to mid-teens in 10 to 15 knots of breeze. The boats are extremely weight-sensitive. After about four or five tacks, both boats popped out the Gate, and our short ride was over as the chase boat picked us up before the 45s bore away.

When you get aboard an Oracle Racing chase boat, you're likely to see a few faces you might recognize. In this case it was design team member, coach and multiple Cup winner Mike Drummond who was taking video of the maneuvers while Volvo Ocean Race navigator Ian Moore worked away on a laptop. After a quick blast into the Golden Gate YC, our short day on the water was over, but our lasting impres-

sion is that the America's Cup 34 is going to be one gnarly ride.

Parting Shot

If there was anything about the AC 45s' visit that really resonated with us — apart from the sheer awesomeness of watching them pulverize the Bay, it was the realization that all the whinging and moaning about how the move to multihulls gives Oracle Racing an unfair advantage is bull. After seeing this all go down, we wondered, "What are the AC 72s going to look like?" With a wing nearly twice as tall, and speeds probably some 15 knots faster — the 45s were doing high-20s — the 72s



GILLES MARTIN-RAGET

The schooner 'America' provided a stable viewing platform for the legion of journalists who went out for a day on the Bay and a look at the AC 45s.

will be so close to the edge that this Cup will probably come down to who can keep their boat upright the longest. The only advantage Oracle has dealt themselves is making the other teams survive a Bay summer before the September '13 match date.

— latitude/rg

Richmond Yacht Club 2nd Annual

RICHMOND RIVIERA REGATTA

Benefitting The Richmond Riviera Fund
Proceeds go directly to Charity!
Register at www.richmondyc.org after July 15th

3 Days of Fun On & Off the Water!
August 12th-14th 2011

"A Taste of Richmond" - Friday Aug 12th
Party with a Conscience Evening Fundraiser
Local Restaurants & Wineries share their tastes of culinary specialties and latest vintages.
Live and silent auctions.
Live jazz band - "Freddie and the Freeloaders"
Ticket Price: \$50, on sale now at www.richriv.com

"Buoy Racing & Party" - Saturday Aug 13th
2 Divisions - Deep Water Division & Riviera Division
Dance the night away to the sounds of "Boogleman"

"A Bay Tour Race" - Sunday Aug 14th
2 Divisions - Deep Water Division & Riviera Division

But Wait, There's More...

ALSO MARK YOUR CALENDARS FOR ONE GROOVY WEEKEND AT THE RICHMOND YACHT CLUB THE 2011 GREAT PUMPKIN REGATTA

2 DAYS OF RACING PLUS 1 AWESOME PARTY
'DEAD HEAD PUMPKIN - 2011'
OCTOBER 29TH & 30TH

MASTER MARINERS



If you've never seen the spectacle that is the Master Mariners Benevolent Association's Annual Regatta, you're missing out. Although this year's event on May 28 didn't get the perfectly glorious conditions of last year's, the sun held the occasional moisture-laden cloud at bay until after the racing was over. And let's face it, no weather could diminish the stunning sight of 66 classic (and almost exclusively) wooden boats plying the Bay at various angles, rails down, with bones in their teeth.

With over 65 classic boats in 12 divisions canvassing the water on different courses in the 20-knot westerly, the Central Bay looked like it had been put through a time machine.

The Sausalito YC ran the race as is customary, and the MMBA's lick-your-finger-and-raise-it-in-the-air rating system was there for some semblance of equality. But let's face it, no one is doing inclination tests.

This editor was lucky enough to join the crew of Dan Spradling's 1950 S&S 52 *Bounty* for the race. In his pre-race briefing, Spradling advised his crew that for many of the skippers, this would be the only day all year they would spend racing — the other 364 are spent varnishing — and to not expect other boats to really know the rules. While the racing rules are necessary to a certain degree, the only important rule is that if you're a steward to one of these anachronisms, that it's be your passion.

In its modern era, which began in 1965, the event has drawn some of the West Coast's most gorgeous wooden boats, but perhaps most importantly the boats you see here aren't museum pieces, they're actively sailed boats. Some are liveboards, some are daysailed. Some introduce hundreds of kids to the joys of sailing every year. They're all living, breathing legends, many of whom call the Bay home, and we're better off for their presence and for the community of sailors who preserve and sail them

— **latitude/rg**

Spread — 'Dauntless' rolls over 'Nautigal'; insets, from left — 'Corsair' flying everything she has; rolling aboard 'Bounty', a little color in the fisherman.

ALL PHOTOS LATITUDE/ANDY EXCEPT WHERE NOTED



— CLASSIC



MASTER MARINERS



Clockwise from top-left — 'Goldilocks' gets trapped under 'Papoose'; 'Nautigal' with a spinnaker up; 'Polaris'; this is about as small as they come; 'Bounty' rolls across the slot; the crew of 'Dauntless' crosses the finish line; 'Pursuit' was the biggest belle at the ball; 'Alma' trucking along; 'Bolero' reaching across the slot; 'Taihoa' took Gaff 2 this year, swapping places with 'Sequestor'; 'Tiger' and 'Eventide' had a horrendous collision before the start; 'Yankee' tries to roll over the top of Chorus'.



DAVE KEANE

— CLASSIC



MASTER MARINERS

MASTER MARINERS (5/27)

BIRD — 1) **Robin**, Patrick & Cissy Kirrane; 2) **Polly**, Bill Stucky; 3) **Widogon**, David Cobb. (4 boats)

BIG SCHOONERS — 1) **Gaslight**, Billy Martinelli; 2) **Alma**, National Park Service; 3) **Freda B**, Marina O'Neill and Paul Dines. (4 boats)

GAFF 1 — 1) **Brigadoon**, Terry and Patti Klaus; 2) **Bluenose**, Dennis Peitso; 3) **Yankee**, Yankee LLC. (3 boats)

GAFF 2 — 1) **Taihoa**, Jody Boyle; 2) **Sequestor**, Hans List; 3) **Briar Rose**, John T. Ough. (7 boats)

GAFF 3 — 1) **Andrew Mulligan**, Stephen Canright; 2) **Stardust**, Mary Moseley; 3) **Mercy**, Shawn Jonutz. (3 boats)

MARCONI 1 — 1) **Bright Star**, Ted & Laddie Hall; 2) **Pegasus**, Peter Hayes; 3) **Bolero**, Tim Murison. (10 boats)

MaARCONI 2 — 1) **Unda**, Dean Gurke and Dee Dee Lozier; 2) **Ingwe**, Jay Gardner; 3) **Nautigal**, Jeff and Karen Stokes. (8 boats)

LAPWORTH 36 — 1) **Papoose**, Allen Edwards; 2) **Leda II**, David James. (2 boats)

MARCONI 3 — 1) **Corsair**, SF Whaleboat Association; 2) **Viking-Red**, SF Whaleboat Association; 3) **Adagio**, David Howell. (10 boats)

MARCONI 4 — 1) **EOS**, K. Dunlop/ S. Mavromihalis; 2) **Flirt**, Peter Strietman; 3) **Morning Star**, Barbara Ohler. (5 boats)

BEARS — 1) **Chance**, Anselm Wettersen; 2) **Kodiak**, Peter Miller; 3) **Goldlocks**, Mathieu Kepler. (9 boats)

OCEAN — 1) **Chorus**, Brad Asztalos; 2) **VIP**, Don Taylor; 3) **Echo**, Jack Coulter. (4 boats)

Complete results at: www.mastermariners.org



DAN BAKER

The raft-up at Encinal YC was really well attended, but the rain came uninvited.



NEW SLIPS!
Now taking reservations
for 40' to 60'

Emeryville Marina

ON THE BAY

When you call Emeryville Marina Home...
...call this your backyard!



Slips from 20-65 ft
Full Amenities - including
Fuel Dock & Pumpout Station





(510) 654-3716

www.emeryvillemarina.com

Come Visit Us Today!

SOUTH BEACH SAILING CENTER

at the
beautifully renovated Pier 40 in San Francisco

2011 To-Do List

It's easy as 1-2-3

- 1. Call Liz about
new cushions*
- 2. Choose your style*
- 3. Go sailing!*

415.543.1887

nbmc@earthlink.net
www.northbeachmarinecanvas.com
Pier 40, The Embarcadero
South Beach Harbor, San Francisco

*Look good for the America's Cup
Challengers. Call now, then go sailing!*

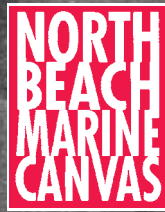

DO IT ONCE. DO IT RIGHT.

Fastnet 1979. Ted Turner, Tom Relyea, and a crew of 17 others win the race by safely getting around the rock in 60 knot winds on board "Tenacious".

**Ted Turner won't take your call.
Tom Relyea will.**

South Beach Riggers

415.331.3400

www.SouthBeachRiggers.com



Scan with your Smartphone and learn more about our services and offerings.

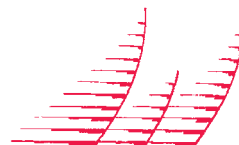

Westwind

**Washing, Waxing, Varnishing
and Interior Cleaning**

*Look forward to seeing
your boat...*



*"We were on 'Mechaieh'
this a.m. - the bright-
work looks great. You
guys do great work.
Thanks again,"*

*- Kent Smith,
'Mechaieh'
32' Traveller*



Serving the entire Bay Area for more than 25 years.



westwinddetailing@sonic.net
www.boatdetailing.com



Adjacent to South Beach Harbor and AT&T Park • Close to dozens of fantastic restaurants and shops

THE MAIDEN &

Once upon a time there was a young man who dreamed of sailing the seven seas to a world of adventure, but on the eve of his departure he met a fair maiden who stole his heart away. Forced apart by fate — and an excellent

weather window — the sailor feared he might never see his lady love again, but they were soon reunited and lived happily ever after. Or at least for the next six months, anyway.

The story of Brian Coggan, 26, and Alana Carrara, 24, begins

much like your everyday fairy tale — love discovered, love lost, love renewed — but, really, it's the details that make a story interesting.

Brian grew up sailing on San Francisco Bay with his parents and older brother. "They put me in San Francisco YC's junior program when I was seven," he recalls. "I was out there getting scared in El Toros." But as soon as he hit his teens, Brian lost interest in sailing — until his folks bought a Schumacher 40 named *Auspice*, that is.

Auspice was built on the East Coast, then moved to Wisconsin to sail the Great Lakes. Brian's parents — Jim and Kim Coggan — bought the boat when Brian was in high school, and took the boys with them for some Great Lake cruising before trucking *Auspice* back to the Bay.

Though the boat was meant to eventually become the family cruising platform, Jim raced her heavily over the next five years or so. "My dad's an avid racer," says Brian, "and I think the ocean racing program he had going sort of distracted him from their cruising plans." Brian raced with his dad aboard *Auspice* through his later high school years and all through college, primarily on offshore races, including a Pacific Cup.

But the cruising plans finally won out and, in the fall of '07, the family of four sped down the coast and up to Loreto in the unfathomable timeframe of just two weeks. "After leaving the Bay, our first stop was Isla Guadalupe five days later," says Brian. "We hardly ever spent the night anywhere after that — we'd anchor somewhere, clean up, go for a walk ashore, and then just around sunset, Dad would say 'No sense wasting the

night sleeping,' and off we'd go."

Once the boat was settled, the parental units flew back home while the boys stuck around. "I only stayed a week or so," says Brian, "but my brother, Chris, stayed until his tourist visa expired — six months. Our parents were commuter cruising at that point."

Auspice spent two seasons in Mexico, with Jim and Kim popping down for a few weeks at a time when they could, before taking off for good in May '09. "Within one month, my dad sold his dental practice, we cleaned and rented the house he's owned since the '70s, and I drove him down to San Carlos in the family's '82 Volvo," recalls Brian. Kim met Jim in Loreto, and then the freshly retired couple made tracks for Cabo, followed by the Marquesas. (Check out this month's *Changes* for an update from the Coggans, currently in Fiji.)

Having graduated in '07 with a de-

gree in geology and environmental studies from Whitman College in Walla Walla, WA, Brian was at a crossroads. He knew sailing was in his future but he wasn't quite sure where it fit. Then he caught wind of a unique academic opportunity called the Watson Fellowship. The way Brian tells it, this particular fellowship gives new grads \$20,000 to pretty much do whatever they want as long as they stay out of the U.S. for an entire year. "Some people learn salsa dancing and some go river rafting, though there's an academic element as well," he notes.

Inspired by a friend's experience with the fellowship, Brian applied, outlining a year's worth of foreign cruising — oh yeah, and learning about the local geology, blah, blah, blah. He was turned down but the application committee left him with some encouraging words. "They console you for not getting it by saying, 'We hope you know these are achievable dreams,'" he says. Though he was disappointed, the seed was planted.



Brian and Alana had a fairy tale start to their relationship.



Isla Santa Catalina was home to giant cacti, as well as less photogenic residents.



THE LOST BOY

ALL PHOTOS COURTESY LOST BOY

For the next year, he worked — everything from guiding kayak trips to substitute teaching — and saved to buy a boat. He looked at many, considered a handful, but finally bought a Wylie 28 in January '08. "It was pretty much exactly what I wanted and already had a lot of the stuff I'd want to go cruising," Brian says.

But that didn't mean the boat was cruise-ready; plenty of work and upgrades were needed. It was another year and a half — last fall — before the newly christened *Lost Boy* was ready to sail under the Gate.

But by then, Brian was having second thoughts . . .

Alana, who grew up on powerboats



In addition to exploring aboard 'Lost Boy', Brian and Alana swam with baby sea lions, were overtaken by a 1,000-strong pod of dolphin, and led kayaking trips to earn money.

in Connecticut, graduated from Cal last year as a member of the school's sailing team. "I'd sailed with friends on the Bay before, but it wasn't until my senior year that I joined the team — it was like throwing the baby in the water and hoping she'd swim," she laughed. But Alana's skills improved and she spent her second semester on the women's varsity team.

After graduating with a degree in linguistics, Alana decided that she wanted to go to med school for pediatric immunology — "I want to work with AIDS kids in Africa" — but she needed to take a number of science courses at the College of Marin so she could take her MCATs.

She figured living on a boat would reduce her expenses, so her Cal sailing coach, Paul Heineken, who just happened to be an old friend of the Coggan family, connected her with Brian. "He was so sly about it," she says, "but he was setting us up — and it worked!"

After their initial email contact, which both confirm was purely platonic, it was another several months before the pair finally met — the day before Brian's initial departure date. "That was

my goal, but it'd already been pushed waaaaay back," he insists.

Alana had asked Brian to look at a Newport 30 she was thinking of buying, then the duo went out for a sail on *Lost Boy*. Light winds, porpoises splashing, a gorgeous sunset and a random fireworks show off Tiburon made for a decidedly romantic evening, one that neither wanted to end. Over the course of the next few weeks, Brian played the 'weather card' on his southbound crewmember, delaying their cast-off date again and again.

"He told me he wasn't sure he wanted to go now," says Alana, "but he'd planned to do this trip for two years, and I didn't want him to give up his dream for me. It'd be easier for me to join him." But Alana had to take a class and was buying a boat — the chances of her joining him on the trip were nil. With a heavy heart, Brian and his crew Jenny sailed under the Gate on November 23, the same day Alana was

going to buy the Newport, which would tie her down with slip fees.

"Thank goodness the guy sold the boat out from under me that day," recalls Alana. Shortly afterward, she discovered she could postpone taking one of her required classes and an idea developed. "She was very strategic about telling me," notes Brian as Alana chimes in, "I didn't want to scare him off!" But the two young lovers were anxious to see each other again, and plans were made for Alana to meet Brian in Loreto in January.



There were many light-air days on the Sea of Cortez.

The next sixth months were a whirlwind of adventure, exploring and sailing . . . lots and lots of sailing. "We sailed almost all the time in the Sea," says Brian. "I think we used a total of about 20 gallons of fuel the entire trip, including the Bash home."

Though much of their time in the Sea was admittedly spent "drifting around," *Lost Boy* did get at least one spanking when a northerly storm blew through Puerto Escondido. "We'd just gotten back from a week and a half in the islands and we thought we'd go camping ashore for awhile, just to get off the boat," Alana reports. "We bought some food and were going to set off the next day, but that night it started blowing 50 knots and we were stuck for three days." Even on the Bash home, the couple say they never saw over 30 knots.

At the beginning of their trip, the energetic duo had an ambitious itinerary: "We were going to go to the northernmost point of the Sea, then to Mazatlan, then go back to Baja," says Brian. "We made it to about 30 miles north of Loreto when I asked, 'What do you think of turning around?'"

Scrapping their original plans for a more *mañana*-esque approach to their cruise, Brian and Alana spent time ex-

THE MAIDEN & THE LOST BOY

ploring spots off the beaten track, such as Isla Santa Catalina, just off Agua Verde, known for its giant cacti. The pair were eager to explore, but reports of rattlesnakes made Brian nervous. They met some folks who were camping on sharp rocks instead of at a more comfortable area nearby, because they'd encountered some aggressive snakes there. Wisdom finally won out and the pair cut their hike short.

In fact, hiking was a major part of their routine, but as Brian points out, "when you're moving from anchorage to anchorage, your routine gets all messed up." Alana confirms they're both in the worst shape of their young lives because of the sedentary nature of cruising.

Then, almost as soon as it had begun, their cruise was coming to a close. On April 14, *Lost Boy* left Cabo bound for the Bay. The couple says the Bash was,



Brian and Alana will live aboard while she goes to school and he figures out what he wants to do when he grows up. Regardless, local cruising in the Delta is high on their priority list.

well, a bash, and that they did everything wrong — rounding capes during the day, sailing most of the way instead of motor-sailing, and so on. But they were able to visit friends all along the California coast and do the surfing they'd wanted to do — but hadn't had the time for — in

Mexico.

Around midnight on June 4, *Lost Boy* sailed under the Golden Gate and took a slip at San Francisco YC for a few nights before her weary crew made their way to their new home at Richardson Bay Marina in Sausalito — just a couple weeks before Alana's summer classes were scheduled to start.

No matter how romantic the beginning of a liaison can be, we all know life isn't a fairy tale. Cruising in tight quarters can test even the most stalwart of couples, and the perils of a new relationship can be even greater. But as the saying goes, what doesn't kill you only makes you stronger, and it's clear this young couple's relationship has muscle thanks to the storms they weathered together.

— *latitude/ladonna*

It's Beautiful, It's Private, It's Home



Making boating easier – and more fun! – is what Oyster Cove is all about. That's why we rate number one with many Bay Area boaters. Oyster Cove is an exclusive yet reasonable facility of 219 berths, accommodating pleasurecraft in slips up to 60-ft long. **Oyster Cove is the private Peninsula marina closest to bluewater boating.** No other private Peninsula marina is better situated or offers nicer, fresher surroundings.

OYSTER COVE MARINA

385 OYSTER POINT BOULEVARD #8A,
SOUTH SAN FRANCISCO

(650) 952-5540

- Berths 30 feet to 60 feet
- Double Finger Concrete Slips
- Five Minutes from SFO
- Heated Dressing Rooms & Showers
- Laundry Room
- Nightly Security Patrol
- Complimentary Ice
- End Ties Available at \$5.95/Ft!

www.oystercovemarina.net

BAJA HA-HA
BOAT SLIPS
SAIL FISH
RESORT
LIVE ABOARD
VACATION
EAT SWIM
PLAY RELAX

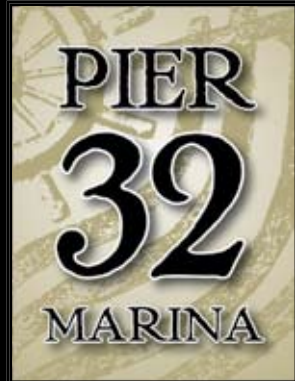

www.pier32marina.com

THE RESORT MARINA
 3201 Marina Way
 National City, CA 91950
 619-477-3232

Baja Ha-Ha Special
\$1.00 per ft per day

**CACTUS GROW IN MEXICO
 FOR A REASON**

One More Good Reason For a
CRUISE RO WATERMAKER

The Cruiser Affordable Watermaker

Visit
www.CruiseROWater.com

(619) 609-3432

**ORDER
 NOW FOR
 MEXICO!**

20GPH for \$3995 • 30GPH for \$4850

**FULL SERVICE MOBILE
 RIGGING**



Competitive Rates • 17 years experience
Firm labor quotes on most projects



Alameda

yachtcheck@yahoo.com



Call John Hansen
(510) 815-4420

THE ZEN SAILING

It hasn't exactly been an 'out of the mud grows the lotus' experience, but it's been within spitting distance.

As you'll recall, our first sail with the *La Gamelle* syndicate's Olson 30 was to



The Oakland Estuary's Zen Sailing Zone.

the yard in Alameda, during which time we nearly killed ourselves in a nautical box canyon. And our first official sail, after the haulout, was in a Memorial Day Weekend rainstorm. For some reason our foul weather jacket wasn't waterproof anymore, and we were wearing sponge-like Levi's. We nearly died of hypothermia on our way to *La Gamelle's* endtie at Marina Village.

But none of this mattered, for we kept remembering that 'the master takes action by letting things take their course'.

The nice thing about adventures starting poorly is that it's almost impossible for things not to get better. And that's exactly what's been happening. In the 20 days after *La Gamelle's* launch, we did seven Zen Estuary meditations — meaning sails from off the Encinal YC to the mouth of the Estuary and back — and three shorter sails. Not only have the last several been trouble-free, but the downwind legs have been in warm sunshine — something that's not always easy to find around the Bay.

We've yet to catch a good ebb, so it's usually taken us about 25 tacks — we keep a record of all our tracks on our iPhone using the Navionics app — and one hour to sail the four miles to the mouth of the Estuary. That's using a full main and a #4. One time we tried a #3 with a full main, but with just two of us aboard, the 3,600-pound boat was

De Mallorca suddenly felt bloated, but not from anything she ate.

overpowered in as little as 13 knots of wind. Buddha would be content to sail with a #4, so we are, too.

Depending on the strength and consistency of the wind, it's usually taken us about an hour to make it back down the Estuary to the Encinal YC finish line — although once we did it in



ALL PHOTOS LATITUDE / RICHARD

38 minutes and the next day scored a PB of 37 minutes. If we weren't Zen Sailing, we'd shoot for covering the entire course in 80 minutes.

Since speed isn't our goal, we fly just the main and #4 even when sailing downwind, and we don't even bother to wing the jib out on a pole. Besides, when you're sailing an Olson downwind at only about four knots, the water coming off the transom makes the sweetest whisper. To us, it's the nautical equivalent of a Buddhist chime, gong, or tingsha, celebrating the genius of George Olson.

Having only sailed in the Estuary sporadically in the last bunch of years, we'd forgotten how pleasant the conditions are. Most of our *La Gamelle* sailing has been in five to 15 knots of wind, wind that's a lot warmer than what blows through the Gate or down off the fog-covered hills of Sausalito. And except for the wakes of passing powerboats and ferries, it's flatwater sailing that is so conducive to meditating on the streaming of the jib telltales. At least until Jonathan Livingstone sails by on his Wylie 38 *Punk Dolphin* and shatters our reverie by holling, "You need more outhaul!"

There is considerable traffic on the Estuary on weekends. But with an ultra nimble and responsive little boat such as an Olson 30, avoiding contact with other sailboats, tugs, barges, container ships, rundown wharves and restaurants becomes a meditation within a meditation. "Be the boat," Zen Master Chevy Chase once said, and we've come to understand what he meant.

Naturally, we've had our share of minor mishaps, too. One afternoon, there was a loud psssst sound, and for about 15 seconds we couldn't figure out where it was coming from. But then it looked as though Dona de Mallorca was bloating into Danny de Vito's daughter right before our eyes!

It was actually her automatic life vest accidentally going off under her jacket, almost strangling her.

A few moments later, we heard the always-anxiety-inducing sound of a stainless fitting bouncing off a fiberglass deck. It turned out to be only the top of the bolt that keeps the rudder from falling out of the boat. We used a bit of



electrical tape to keep the bottom half of the bolt in place, keeping the rudder in the boat, allowing us to resume our meditation.

We've enjoyed *La Gamelle* so much that sometimes we've even braved the



traffic from from Marin to Alameda just to fool around on her. Our favorite pastime has been simplifying her. Having gotten rid of the masthead light and wind sensors, the depthsounder and knotmeter, the GPS and the VHF, the spare lines and spare fenders, the cupholders and

CHRONICLES



Spread: An Islander 36 leads the afternoon wing-on-wing parade down the Estuary. Insets upper left: 'La Gamelle's broken rudder post bolt; Sailing in the shadow of imports from China; A Corsair tri heads to weather. Inset lower left; The K-38 'Chorus' heads home after the Master Mariners.

the cushions, we were running short on things to remove. Then we spotted the cabin and 'nav station' lights. "Less is more," says Buddhist Governor Jerry Brown, so we got rid of them, too.

We didn't sense much spiritual energy coming from the Honda 5 hp on the transom either, so we took it back to the office. When we need a break from banging on the computer but don't have enough time to go to the boat, we mount the engine in a plastic dumpster full of water. We then start her up, put her in gear, and watch the water swirl around. Yep, it's a whole different kind of meditation — although the smoke and noise are distractions.

It's harder to meditate when there are a lot of people around, but it's been difficult for us to avoid people in the Estuary. Between the passing boats, chandlerlies, marinas, yacht clubs and

the docks, we've bumped into countless old friends and made scores of new ones. And imagine the coincidence of the boat berthed in front of *La Gamelle* being a big catamaran — the new Prout 50 owned by David and Elena Esser. Having known them for all of three days, we got the invite to their wedding reception aboard *Tigress*, so of course we attended.

There was an even bigger coincidence when we took an Aussie friend, who had come all the way to Alameda from Queensland to buy a cruising boat, to the Encinal YC to have a drink. When we walked into the club, we were surprised to be informed that we were not only members, but had been for eight years! Unable to recall ever signing any checks for monthly dues, we asked Jessie, the lovely woman who runs the office, if she could check to confirm our status. "I've got good news," she said when she

returned. "You have an honorary membership, so you only have to pay for food and drinks."

"You mean to tell us," we replied in a combination of shock and skepticism, "that we can meditate on our boat up and down the Estuary, tie her up at our Marina Village end-tie, walk over here to the club, charge a drink at the beautifully redesigned and rebuilt bar, then go jump in the beautiful new pool?"

"That's right," she said with a big smile.

"Cool!"

See what we mean about going from the mud to the lotus?



Jessie, giving us the good news.

As we sipped our cocktail, we watched the Oakland YC Wednesday beer can fleet sail by. It was still plenty light out — and so was the wind — so we saw many boats and people we recognized. Kame Richards of Pineapple Sails had so many people aboard his Express 37 *Golden Moon* that it reminded us of the mobs Bill Lee used to host on *Merlin* for Wet Wednesdays in Santa Cruz.

And then, were our eyes deceiving us, or was that bearded fellow at the helm of the Cal 29 about to round the mark really Jim Jessie? We know it was exactly 30 years ago that Jim and his wife Diana hooked up, because we — including our then six-month-old daughter — all went sailing off to Honolulu aboard the great Farr 52 *Zamazaan*. Jim and Diana hadn't even started to go around the world on their Lapworth 48 *Nalu IV* yet. So many great sailors, so many great sails, so many great sailing memories — all coming to life again.

It's a cluster up at the leeward mark of the Oakland YC's Wednesday night race. Zephyrs and a flood complicate the rounding.



THE ZEN SAILING CHRONICLES

It's with considerable sadness that we realize that we only have about 10 more days on the Estuary Zen Zone sailing circuit before it's time to move on the Richmond Riviera Zen Zone Circuit. We haven't even left the Estuary yet, and we're already missing it. But we think we're going to come back soon. For the warm run back down the Estuary. For the sailing to Quinn's and other dockside restaurants. And yes, for the pool at the Encinal YC — where, did you know, we're members!

Our sadness is tempered with the knowledge that Buddha — or was it Confucious? — said that change is as inevitable as the sun rising each day. And that since we can't fear the rising of the sun, we should embrace change.

We have embraced change with *La Gamelle*, although we were tentative at times, and didn't get much initial support from Dona de Mallorca. We remember the first couple of times we saw *La Gamelle*. She was mossy on the outside and messy



Sailing, swimming and sun, the newly spruced up Encinal YC has it all.

on the inside. And when we climbed aboard, she seemed — and indeed was — exceedingly tippy to a person used to a 63-ft cat. As for folding the main, we couldn't even remember how we used to do it by ourselves without lazy jacks. When we tacked, we had to remember to duck so we didn't get decapitated by the boom. And those first big gusts that knocked us over 20 degrees, well, after the stability of a cat, heeling like that was the definition of change.

Flash forward just a month or so, and

it's just as Buddha promised, change has been good. *La Gamelle's* exterior and interior aren't perfect, but they are as spiffed up as some Buddhist temples we've seen in Asia. Her bottom is clean. The blue highlight motif on the house and boot stripe have been changed to a sunny yellow, and if we ever

find the time, we're going to liven up the teak bits with Caribbean baby blue paint.

As for sailing *La Gamelle*, we're happy to report that we can get underway within three minutes of arriving. Step aboard, raise the main, undo the docklines — and we're meditating, baby!

All joking aside, the *La Gamelle* experience has been tremendously rewarding on many levels, so much so that even Dona de Skeptic has gotten religion about Zen Sailing. It's up to you, of course, but you might consider converting, too. Or if you've lapsed, reviving your devotion to sailing.

— latitude/rs

TAKE THE DEAD OUT OF DOWNWIND SAILING

Dead downwind cruising can be relaxing and fun. A Forespar Whisker Pole will help fill your headsail with life, while putting a stop to annoying sail flop.



WORLD'S #1 WHISKER POLE

- Twist Lock or Line Control length adjustments
- Carbon, Aluminium or 50/50 combos

Tel: 949 858-8820 • www.forespar.com



YOU HAVE THE
POWER

to make them forget
TELEVISION
was ever invented.



GET THE TRAINING YOU NEED
TO GET OUT ON THE WATER
WITH A POWERBOAT.

Ready to get the kids off the couch and onto the open water? First, make sure you know how to operate your powerboat safely. You'll find everything you need at uspowerboating.com, from videos and nearby on-the-water courses to an online quiz that lets you instantly test your powerboating knowledge.

YOU HAVE THE POWER.
START USING IT RESPONSIBLY AT
USPOWERBOATING.COM



**VENTURA HARBOR
BOATYARD**

"Quality without compromise"



TWO TRAVELIFTS

**HAUL OUTS TO 160 TONS
FULL LINE OF MARINE SERVICES
PROFESSIONAL STAFF**

twitter (805) 654-1433 Find us on Facebook

1415 Spinnaker Dr., Ventura, CA 93001
www.vhby.com or info@vhby.com

OFFSHORE

Racing or Cruising
Offshore?

Buy, rent or service
your liferaft at Sal's!



INSHORE

Cruising the Delta or
the coast of Mexico?

A quality, hypalon
tender is the way to go!

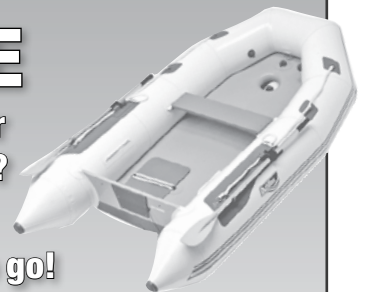

SAL'S
INFLATABLE
SERVICES, INC.

**SALES • SERVICE
RENTAL • REPAIR**

**PHONE (510) 522-1824
FAX (510) 522-1064**
1914 Stanford St., Alameda 94501
salsinflatables@sbcglobal.net
www.salsinflatableservices.com

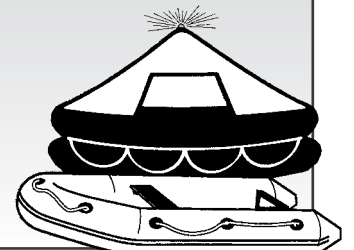

SHARIN' THE LOVE —

Passion for the sport of sailing manifests itself in many forms, and each month we report on a bunch of them: the latest conquests of the West Coast's hottest racers, the far-flung wanderings of world cruisers, the exotic getaways of bareboat charterers, and the childlike



DAVID YEARSLEY

While rowing 'Alma's skipper Jason Rucker ashore, Alice Watts' infectious smile gives a hint about her ever-cheerful nature.

euphoria of daysailing on San Francisco Bay with no particular itinerary.

Regardless of how these and other successful sailors define fun on the water, though, we'd bet that most of them got started in a similar way. That is, back before they knew a keel bolt from a cotter pin, some patient soul took the time to introduce them to the joy and exhilaration of sailing, while mentoring them in the time-honored skills of seamanship. So for a change of pace this month, we're shining our spotlight on a group of big-hearted sailors who've been quietly and selflessly making life-changing impacts

Paul Mixon (right) has introduced more African-Americans to sailing than anyone we know. And solo circumnavigator Bill Pinkney approves!



BLACK BOATER'S SUMMIT

on the lives of West Coast sailors — especially new inductees to our sport — with little or no expectation of acknowledgment. We call this collection of nautical notables *Latitude 38's Roster of Unsung Heroes*.

The remarkable sailors that you'll meet in these pages were all nominated for recognition by readers. (And there were more worthy nominees than we have room to introduce here, so we'll publish a second installment in the future.)

Alice Watts — "My candidate for unsung hero status would certainly be Alice Watts," says Captain Rick Whiting. "She's the ubiquitous first mate of the 82-ft scow schooner *Alma*, operated by the San Francisco Maritime National Historic Park at the Hyde St. Pier.

"Alice has served as mate on *Alma* for more than 15 years. She sails five or six days a week during the season, and runs the deck in a most professional way. Her dedication to teaching kids about sailing, the history and ecology of the Bay and the history of scow schooners is remarkable. Her ability to train the young crew members in running the vessel and teaching the kids is astounding and most professional."

Dave Yearsley seconds the motion: "She has engaged thousands of children and adults, including the disabled, cultural minorities, and at-risk youth in the arts of sailing and marlin-spike seamanship. Alice continues to delight all who board the *Alma* with her smiling presence and competence, while ably assisting Captain Jason Rucker in running the scow." (See www.nps.gov/safr)

Eric Arens — "This one is easy," says Jimmie Zinn. "I nominate Richmond Yacht Club's Eric Arens. This guy has been organizing and running major racing events for many years. The amount of time and effort he has so generously devoted to high quality racing on San Francisco Bay may be equaled by some, but nobody has done it better." (www.richmondyc.org)

Dan McGuire — Ted Biggs told us about the generous spirit of Watsonville's Dan McGuire. "He restores El Toros with at-risk, low-income youth in Watsonville,

then teaches them boat handling and sailing. I donated my grandfather's El Toro to him last year, and he invited me to an annual event where they put that year's boat project in the water and sailed it on a local lake with the kids.

"Not only did they rebuild a bristol woodie El Toro, but the normally rough-edged kids were softened by the experience. I doubt that they laugh and smile like that on a regular basis. Not only does Dan restore old neglected boats, he restores young neglected kids."

Paul Mixon — "My unsung sailing hero is former East Bay resident Captain Paul Mixon," says Joan Jackson. "For the past 14 years, he's organized a flotilla of African American non-sailors in the British Virgin Islands. For me, and many, many others, sailing in the BVI has been a life-enhancing experience.

"The Black Boaters Summit has been about teamwork, camaraderie and trying to bring the love of sailing to a group not well represented in the sailing



community. Typically around 95% of the BBS sailors have never set foot aboard a sailboat before.

"During the past 14 years, lifelong friendships have been formed and many marriages owe their beginnings to the BBS, including that of the ole captain himself, who recently married a lady he met dur-



LATITUDE'S UNSUNG HEROES

TED BIGGS

ing BBS 2009!"

Paul's flotillas are so well-liked that there's about a 60% repeat rate. Even so, he has introduced roughly 1,000 non-sailors to the sport through these catamaran cruises. Paul is now ready to retire, however. So this August's flotilla may be the last, unless someone comes forward to pick up the torch." (<http://bbs2011.blogspot.com>)

"It is so amazing to see the pure joy on the faces of our students when they're sailing."

Eric Anderson — "Eric Anderson has led the Peninsula Youth Sailing Foundation and its programs for many years," explains Dave Olson, "including five or six years past the time his own son left the program to go to college. His efforts have enabled many young folks to grow up as sailors. To me and many others

Left and below: Al Spector (far left) and Danette Davis (far right) share their vision and their passion with blind sailors of all ages.

he's an unsung hero." (www.pysf.us)

Ariane Paul — "Ariane Paul volunteers countless hours to Master Mariners and to Summer Sailstice," says Marianne Armand. "She puts together the boat building contest and organizes the bands — all for the love of the event, and getting people interested in sailing. Not only that but she works like a dog for Master Mariners. I think she more than qualifies as an unsung hero."

Al Spector & Danette Davis — Javier Jerez introduced us to the amazing blind sailing program run by Al Spector and Danette Davis. "Al put together a blind sailing program as an offshoot of his Marin Sailing School venture, and eventually led a blind crew to participate in both national and international regattas representing the U.S. and California. He later put on an international blind sailing



The work Dan McGuire does transforming neglected El Toros into usable sailing craft can help transform young lives.

event in our home waters of the Oakland Estuary, and most recently he tied up with The Treasure Island Sailing Center to train instructors to teach and sail with visually impaired sailors.

"Coupled with his motivation and energy is a fun-loving personality that makes everyone feel welcome and appreciated. He is truly an unsung hero," says Javier.

We consider Al's partner in the program, Danette Davis of Oakland's Lion's Center for the Blind, to be an equally remarkable hero. During races she serves as 'sighted crew', offering info on ship traffic and the proximity of competitors, while Al serves as captain and tactician. "The sailing program has been phenomenal," says Danette, "and it wouldn't have happened without Al's generosity.

"It is so amazing to see the pure joy on the faces of our students when they're sailing. You can see their confidence and self esteem increase almost immediately. Sailing is so perfect for the blind and visually impaired; there's so much information that comes to them through their other senses: They feel the wind on their faces and feel the boat heeling over, they hear the sails begin to flap when they are out of trim, and they feel the hull accelerate when everything is dialed in just right."

This program, which is mostly geared to adults, has so far had participants from 18 to 84. "And we now have a 94-year-old lady who wants to give sailing a try," says Danette. (www.marinsailingschool.com/blind-sailing.html)

Mike Gross — According to John Super and others, Mike Gross of the Monterey Peninsula and Santa Cruz YCs is an exceptional regional race officer. He's a U.S. Sailing judge and an umpire in training. "He will come to your



MARIN SAILING SCHOOL / LIONS CENTER FOR THE BLIND

SHARIN' THE LOVE —



PEGASUS PROJECT

Richard Gillette of 'Pegasus' has been a mentor to hundreds of kids, teaching them about respect and teamwork as well as sailing.

club and sit on a protest hearing about as quickly as my dog can make a steak disappear," says John.

"Almost every weekend Mike can be found doing jury or ump duty somewhere on the Bay. He also is happy to conduct a rules seminar or a 'how to do it' session for race committee people."

Blue Water Foundation founder Lee Stimmel often volunteers for man overboard drills — or "lawyer dunkings," as he calls them.



BLUE WATER FOUNDATION

Richard Gillette — "I'd like to nominate Captain Richard Gillette," says Erik Jones. "He skippers the 51-ft Alden ketch *Pegasus* for the Berkeley-based Pegasus Project, a nonprofit dedicated to educating youth and underprivileged members of the Bay Area about our environment, the Bay and sailing. He got me excited

"There is something magical about Richard. He is like an old soul with a connection to the sea and the earth."

about *Pegasus* and I've since recruited others to become volunteer crew.

"Captain Rich seems to spend every waking hour of every day recruiting volunteers, keeping the *Pegasus* running and finding new ways to reach out to children, military veterans including those who are disabled, cancer survivors, and many more. The man is tireless in his passion to help and educate others about our sport, and bring them into an environment that many would never have had a chance to see, had it not been for his efforts and those of the foundation he helps to run.

"It is an honor to sail with him aboard *Pegasus* and I can tell you first hand, that he has touched the lives of so many. They all walk away at least with smiles, and some disembark with a newly kindled interest in sailing. He is truly an inspiration and definitely a local hero."

Shana Bagley adds, "There is something magical about Richard. He is like an old soul with a connection to the sea and the earth. The world is always brighter after spending time with him." (www.pegasusvoyages.org)

Pegasus volunteers — In his typical selfless manner, Richard Gillette wrote in to nominate his volunteer crew: "The crew are all volunteers who give so much of their time, energy, knowledge and spirit to make it possible for us to take the disadvantaged youth of the San Francisco Bay Area out sailing. They give

so much!

"They often drive long distances and take time off work so these children can have a life-altering opportunity. The crew share their love of sailing and the Bay with these children and ignite a whole new perspective for them. They also share their spirits and hearts with each child. These volunteers really are the heroes that make the Pegasus Project (which has taken more than 8,000 children sailing) so powerful and able to touch so many lives!"

Nancy Novak — A related nomination is that of clinical psychologist Nancy Novak. Cathy Stierhoff explains, "She's the creator of Nancy's List, a grassroots organi-



zation committed to improving the lives of people who are living with cancer and those who love and care for them. As a cancer survivor herself, Nancy knows what it feels like to be isolated, frightened, and powerless. She transformed her experience and created an organization whose mission statement is: 'No one will ever go through cancer alone.'"

An important component of her work is Nancy's Club for children and teens whose lives have been touched by cancer, either through their own diagnosis or that of someone they love. She regularly takes club members on adventurous outings, including sailing trips on the

LATITUDE'S UNSUNG HEROES



LAURANNE LEE

Left: Despite her big boat prowess, Kit Stycket stills likes to goof around in El Toros. Above: High schoolers test their new skills off the Cityfront with the Blue Water Foundation.

Bay, thanks to Diane Andrews of the Sausalito-based Pearson 26 *Release*, and Richard Gillette of *Pegasus*.

Cathy writes, "Nancy, Diane and Rich have created an environment for these kids so that they can forget, for an afternoon, the trauma that they are living with; to escape and have fun!"

The kids' comments are the program's best testimonials: "When I was sailing with my mom and my brother, I forgot I even had cancer," said Gal, age 9. "This is the happiest day of my life," said three-year-old Harry. Both are leukemia survivors. (www.nancyslist.org)

Blue Water Foundation — Like the *Pegasus Project*, the San Francisco-based

Blue Water Foundation is all about getting kids out on the water to experience the fun of sailing and to expand their world view. This nomination comes to us from cruiser Marc Gounard, who volunteered to help out when he learned that the Blue Water's goal is to get every public school youngster out on the water before they graduate from high school.

The brainchild of founder Lee Stimmel, Blue Water's three boats can often be seen out on the Bay with smiling kids learning the ropes. The Peterson 46 *Alita* is based in Emeryville; the Frers 46 *Golden Bear* operates out of the S.F. Cityfront, as does Stimmel's own Hans Christian 43, which is used on special programs.

"Members of the San Francisco Police Department often come out on these field trips,"

explains longtime volunteer Lauranne Lee. "That allows kids to see officers as regular people, as their friends. I think they all get a lot out of it because neither group is in their element — sailing is a great 'leveler' because everyone has to work together.

"Getting out on the Bay is a real education for some of the disadvantaged kids who — believe it or not — don't know the difference between the Bay Bridge and the Golden Gate. Some say they have never seen either one, even though they live within the city limits!"

Anthony Sandberg — Ellen Galvin wrote in to nominate Anthony Sandberg of Berkeley's OCSC Sailing School. "I



ELLEN GALVIN

'Uncle Anthony' Sandberg of OCSC has long been a leader in bringing new blood into the sport of sailing.

don't know anyone else who has spent a lifetime teaching other people about the joys and camaraderie of sailing. I've certainly been the beneficiary of his expertise and his passion for the sport, and as soon as my three-year-old daughter is old enough, she's going to spend a week with 'Uncle Anthony' and his crew to learn how to sail. I'm not just talking about the skills to maneuver a boat, but also how to sail safely and with confidence, which includes showing respect for Mother Nature and for the rest of the sailing community. Oh, yeah, and Anthony also taught me how to tie those pesky knots!"

Kit Stycket — "My friend Kit has been helping kids learn to sail and grow up ever since her own teen years," says Peter Detwiler. "While she's probably most proud of her eight consecutive Sears Cup teams from the Richmond YC ('99-'06), I know how much she's helped scores of kids find their way through the Sea Scouts — two totally different methods of putting kids into boats, but she makes both approaches work. That's why she's my hero.

Clinical psychologist Nancy Novak has brightened the lives of many young cancer victims through the joys of sailing.



CATHY STIERHOFF / NANCY'S LIST

SHARIN' THE LOVE —

"Kit started sailing in the San Francisco YC junior program and with the Sea Scouts in Aquatic Park. And she's still active in making sure that teenage girls in Sea Scouts get all the respect they deserve from the guys. What matters is experience, competence, and respect — not gender. Some of her junior sailors needed more than a racing coach; they needed someone like Kit who would listen to them and keep them from wandering off into an adolescent haze. She took in more than a few kids when they needed something more than their families could offer — acting as a surrogate aunt."

Kit's list of personal racing successes is matched or exceeded by the triumphs of some of the kids she's mentored. She says, "While I'm flattered that a friend of mine nominated me for this honor, I feel it's not about me, but about the success of the young people I've coached." (www.corsair-ship22.org, www.ggyc.org, and www.richmondyc.org)



Shakespearean actor-turned-sailing mentor JP Watts skippers a Sea Education Adventures boat during a Drake's Bay cruise.

Kevin & Lori Wilkenson — Liz Diaz writes, "I'd like to nominate Kevin and Lori Wilkenson of the South Beach Yacht Club for going so far beyond the call of duty at our yacht club — while fully employed — to create such a vibrant and fun junior sailing program, and keep it

so dynamic for all these years! It has been chosen as the Best of the Bay." (www.southbeachyc.org)

Treasure Island Sailing Center staff — "I'd like to nominate the staff of the Treasure Island Sailing Center," says Grant Robbins. "The work they do introducing economically disadvantaged youth to sailing on the Bay at no, or low, cost is truly admirable. Their commitment to adaptive sailing and partnership with the Bay Area Association of Disabled Sailors (BAADS) is a great example of the wonderful work they do. And the fact that they do it all on a shoestring budget, from a reclaimed parking lot on Treasure Island, makes it all the more impressive." (www.tisailing.org)

Mark Miglio — Matthew Davidchuk salutes the work of Mark Miglio, program director for Sailing Education Adventures (SEA). "Mark works tirelessly for this nonprofit to introduce sailing to novices, and to contribute to a bare bones club



MARINE INSURANCE SPECIALISTS

Your best source for Yacht and Boat Insurance tailored to your needs and competitively priced

We Insure:

Sail or Power ♦ Classic or Contemporary
Fiberglass ♦ Aluminum ♦ Steel ♦ Wood

At Heritage Marine Insurance you will find knowledgeable insurance professionals who provide the best service and the finest coverage available today.

To be sure you're getting the best insurance value please contact us for a quote.

www.heritagemarineinsurance.com

800-959-3047

Fax 860-572-5919

classics@heritagemarineinsurance.com

COVER CRAFT

WE'VE MOVED!

Deep water access at KKMI.

Stop in to see our new shop!



All sewing in Tenara thread.

- Classic dodgers and biminis
- Drop-top folding dodgers
- Enclosures • Custom canvas

560 W. Cutting Blvd., #2
Richmond, CA 94804
Inside the KKMI boatyard

(510) 234-4400

Quality
Yacht
Canvas

LATITUDE'S UNSUNG HEROES

that stresses mentoring and community.

"I've recently read the book *Saving Sailing* by Nicholas D. Hayes and feel that SEA has the potential to be an organization that can re-invigorate sailing. By the way, I strongly recommend reading this book. It seems participation is way down, even from 10 years ago, and the younger generation is not sticking with it."

Matthew also thinks former director John Paul (JP) Watts deserves special recognition, as he's been contributing his time, energy and experience for the past 15 years or more. This salty British gent, who is a former Shakespearean actor and theater director, "gives of himself tirelessly." (www.sfsailing.org)

Afterguard Sailing Youth — Several readers alerted us to the good deeds done by Steve and Mary Swift Swan at their Afterguard Sailing Academy in Oakland. In addition to running their small sailing school, they offer low- or no-cost sailing courses for local youth.



RICHARD GILLETTE / PEGASUS PROJECT

Volunteer crewman Dogan Hannah shares his expertise with first-timer Nica aboard the Alden ketch 'Pegasus'.

"Our youth programs began in 2006 and are part of school curriculum by connecting math and science, plus building leadership skills," Mary explains. Kids from Oakland's Street Academy participate in a 40-week, once-a-week elective program that integrates maritime issues with math and science, while

kids from other high schools sail aboard Afterguard boats for phys. ed. credit.

"Our sailing program has not only helped to reduced the drop-out rate, but it has helped kids see a different world outside their three-block neighborhood and the route to and from school." (www.afterguard.net/youth)

It's a great compliment to the West Coast sailing community that it contains so many big-hearted people who are dedicated to sharing their love of sailing in so many ways. If you find their work inspiring, as we do, we suggest you take a deeper look into their programs and perhaps even volunteer to lend a hand (or donate a little cash). As the mentors profited here would probably agree, giving your time and expertise to others often comes with unanticipated rewards.

As Albert Einstein — arguably the smartest sailor ever to hold a tiller — famously said, "The value of a man resides in what he gives and not in what he is capable of receiving."

— **latitude/andy**

LOCH LOMOND MARINA

RARE OPPORTUNITY!
(1) 96-ft end-tie
Plus 26 to 46-ft
slips available

**Completely Rebuilt Marina • Gas & Diesel Fuel Dock • Free Pump Out Station
Modern Launch Ramp • Guest Slips Available • Marine Mechanical Boat Repair
Arena Marine Supply Store • Andy's Local Market • Bait Shop
Land or Sea Canvas • Windjammer Yacht Sales • Loch Lomond Yacht Club**

110 Loch Lomond Drive, San Rafael, CA 94901

Phone: (415) 454-7228 • Fax: (415) 454-6154

www.lochlomondmarina.com

Harbor Master – Pat Lopez • pat@lochlomondmarina.com

**MOVE-IN
SPECIAL**

★★★★★★★★

**THIRD MONTH
FREE!**

A NUMBERS GAME:

One of the most frequently asked questions by those considering the cruising lifestyle is: "How much does cruising cost?" Ask it and you'll likely get an answer that sounds as if it came straight from Buddha's mouth: "It costs as much as you have." As frustrating as that Zen-like response may be, it's the most accurate answer you'll get on the subject. But if you ask a current cruiser "How much does cruising cost *you*?" you'll likely gain some valuable insight into how expensive — or inexpensive — different styles of cruising can be.

We asked that very question in the May 20 edition of *Lectronic Latitude* and we received a number of illuminating responses. Allen

and Kate Barry of the DownEast 38 *Mendocino Queen*, who left San Francisco Bay in '93, are currently cruising in the Caribbean on \$1,500 a month. "However, it's important to understand that we never stay in marinas, and only eat out occasionally — usually inexpensive lunches," they note. "But we are having lots of fun and think it's a great way to retire."

Singlehander Chuck Losness of the Gulfstar 37 *Hale Moana* responded that he's quite content to cruise Mexico on \$350 a month — the same amount as a Mexican couple earning minimum wage would live on. You can find the details on Chuck's budget in *Letters*, where you'll also find reports from Kirk McGeorge

of the USVI-based Hylas 47 *Gallivanter* and the Faulkner family of the Colorado-based Tartan 41 *Hotspur*. Before their son was born, Cath and Kirk McGeorge spent about \$750 a month on their world cruise, and the Faulkners — parents Jim and Meri, kids Tim and Carolyne, and pets Bailey and Bad Kitty — cruise on less than \$2,000 per month in Mexico.

In *Sightings* you'll meet Cindy Holmes and Faith Tamarin who have nearly completed a 12-year circumnavigation aboard their Vanguard 32 *Carmen Miranda*, spending on average \$500-600 a month. And in *Changes in Latitudes*, Rob and Linda Jones share the details on their seven-year cruise aboard their Gemini 3000 *Cat 'n About*. Their monthly

Alana Carrara spent just \$500 a month for this view of the Sea of Cortez.

Third Day's Cost of Cruising, 2009:

	Jan	Feb	Mar	Apr	May	June
groceries/provisions	262.66	324.10	170.35	301.85	455.11	326.89
sundries	30.07	237.91	95.79	80.00	10.11	9.67
fuel/propane	63.74	135.45	64.38	47.73	189.66	157.48
restaurants/food carts	169.22	103.10	79.35	45.24	34.06	25.19
alcohol	8.46	44.27	0	0	0	26.67
taxi/bus	5.77	25.89	14.71	0	4.35	50.37
clothes	115.25	12.95	17.27	10.66	2.54	3.70
marina/mooring fees	56.43	176.69	4.14	3.46	91.82	19.78
phone/email	4.62	10.72	0	0	0	0
boat maintenance	23.08	23.41	206.08	869.38	0	0
boat repairs	38.46	102.29	315.00	165.38	650.00	91.85
spares/equipment	5.54	159.00	760.98	131.27	239.00	250.74
inland excursions	33.85	50.36	0	0	0	0
laundry	37.00	34.65	8.00	7.69	10.87	9.78
souvenirs/gifts	46.00	164.32	32.33	0	0	0
education	3.46	38.95	54.69	69.38	3.19	935.00
tips	19.23	23.65	0.40	10.00	4.35	11.11
boat insurance	175.00	175.00	175.00	175.00	175.00	175.00
medical	0	29.00	0	0	92.89	0
monthly totals	1098.11	1871.92	1998.46	1917.04	1990.17	2294.63

Notes:

March: Air conditioner, new battery charger, water filters, and dive compressor tune-up

April: Bought bottom paint

June: Sailrite & 1 year home schooling materials

THE COST OF CRUISING



budget for the first year was \$1,000, which they say they had no problem sticking to.

On page 98 of this issue, you'll find the story of Brian Coggan and Alana Carrara ('The Maiden & The *Lost Boy*'), two 20-somethings who returned at the beginning of June from a six-month Baja cruise aboard Brian's Wylie 28 *Lost Boy*. The couple say two kayaking trips they guided out of Loreto funded their entire time in Mexico. Three key decisions contributed to their ability to cruise on a \$500 monthly budget: eating a vegetarian diet on the boat, anchoring out, and rarely running the engine (they only used about 20 gallons of fuel during their entire six-

month trip, including the Bash home).

One of the most detailed reports came from the Boren family aboard the Port San Luis-based Hudson Force 50 *Third Day*. The Borens — Rich, Lori, Amy (13) and Jason (12) — started cruising during the '08 Baja Ha-Ha aboard their previous *Third Day*, a Pearson 365 (they upgraded a year ago). They've kept a detailed accounting of their monthly spending on their site, www.svthirdday.com.

"We post our monthly cruising numbers as a way to dispel the myth that you have to be wealthy or have to win the lottery to go cruising, especially as a family with kids," Rich explains.

BRIAN COGGAN

Third Day's Cost of Cruising, 2009 cont'd:

July	Aug	Sept	Oct	Nov	Dec	Totals	Avg
279.78	210.26	544.38	161.14	309.46	357.20	3703.18	308.60
737.43	109.93	112.04	96.17	0	151.69	1670.81	139.23
20.00	119.85	0	176.12	50.01	91.60	1116.02	93.00
68.95	33.16	56.69	11.12	42.04	150.52	842.40	70.20
40.00	28.40	0	24.74	0	3.85	176.39	14.70
0	0	0	0	15.38	36.78	153.25	12.77
116.00	0	39.35	0	0	1.54	319.26	26.60
192.59	7.58	240.58	67.04	10.23	43.85	914.19	76.18
25.00	0	0	13.79	0	3.85	57.98	4.83
485.22	7.60	305.48	0	375.00	19.23	2314.48	192.87
28.59	156.10	2183.57	0	83.13	124.53	3938.90	328.24
428.00	0	132.15	0	7.09	0	2113.77	176.15
579.04	19.01	214.47	0	0	25.69	922.42	76.87
3.70	13.29	6.82	0	9.45	0	141.25	11.77
140.17	0	40.30	0	0	49.52	472.64	39.39
16.19	0	0	0	0	7.69	1128.55	94.05
5.93	12.98	22.73	2.75	8.64	14.77	136.54	11.38
175.00	175.00	175.00	175.00	175.00	175.00	2100.00	175.00
4.37	0	0	0	79.35	379.27	587.88	48.74
3345.96	893.13	4073.56	727.87	1164.78	1636.58	22,012.21	1917.68

Notes:

July: LED replacement bulbs & spear guns

September: New anchor windlass

November: Haul-out

A NUMBERS GAME:

Third Day's Cost of Cruising, 2010 (nine months):

	Jan	Feb	Mar	Apr	May	Aug	Sept	Nov	Dec	Totals	Avg
groceries/provisions	292.73	240.62	581.41	209.58	209.58	216.30	338.15	240.93	200.33	3012.33	334.70
sundries	3.57	23.31	38.84	2.42	0	1.76	0	3.00	0	72.90	8.10
fuel/propane	123.81	50.92	67.82	211.79	256.00	196.32	469.24	52.80	123.60	1552.30	172.48
restaurants/food carts	107.45	102.77	128.07	178.94	55.65	66.16	79.49	23.69	66.14	808.36	89.82
alcohol	13.95	10.77	44.53	4.76	14.75	7.20	76.92	0	0	172.89	19.21
taxi/bus	0	28.92	39.50	23.87	23.00	19.28	0	0	20.96	155.53	17.28
clothes	12.31	15.00	28.80	22.18	0	7.20	9.23	0	0	94.71	10.52
marina/mooring fees	18.55	71.08	0	50.64	93.15	154.00	35.00	40.00	56.40	518.81	57.65
phone/email	4.77	80.92	42.37	42.31	42.31	40.00	51.69	50.30	42.30	396.97	44.11
boat maintenance	0	0	10.22	20.47	6.93	0	3.60	0	32.24	73.46	8.16
boat repairs	6.09	24.62	15.38	8.06	88.71	0	0	65.00	0	207.87	23.10
spares/equipment	42.92	38.15	26.15	0	0	184.16	0	0	0	291.39	32.38
inland excursions	0	0	0	0	4.56	0	0	0	0	4.56	0.51
laundry	16.87	2.08	0	9.98	10.00	0	0	0	0	38.93	4.33
souvenirs/gifts	12.73	19.23	12.50	29.87	75.43	0	2.38	28.24	209.19	389.58	43.29
education	11.54	0	0	9.48	0	0	0	39.86	0	60.88	6.76
tips	1.54	5.62	3.12	3.94	11.00	4.00	3.85	8.80	12.00	53.86	5.98
boat insurance	175.00	175.00	175.00	175.00	175.00	133.00	133.00	133.00	133.00	1407.00	156.33
medical	44.50	49.23	0	1.19	0	0	153.85	80.00	0	328.77	36.53
monthly totals	888.32	938.23	1213.70	1004.48	1072.78	1505.37	1356.40	765.62	896.16	9641.07	1071.23

Notes:

June, July & October not counted because they were not actively cruising in Mexico
May & August marina fees high due to transferring gear to their new boat

March groceries include provisions for summer cruising

September medical fees for new crown plus cleanings for the entire family

In reviewing their detailed expense sheets, shown above and on the previous pages, it's clear that during their first year, the Borens were still getting a handle on their expenses — the average monthly total for '09 was \$1,917 but that figure dropped last year to \$1,071. For a family of four!

Of course statistics can be misleading if all relevant factors aren't included, and last year's acquisition of the new *Third Day*, along with the sale price of the old one, were excluded from their totals because they weren't actual "cruising costs." The three months the family

Kids can help save you money — and create a masterpiece — at the boatyard by lending a helping hand . . . or fin.



COURTESY THIRD DAY

spent buying and outfitting the new boat, as well as moving aboard, were also excluded for the same reason. "We weren't actively cruising in Mexico," notes Rich. But he believes that their expenses would have remained essentially the same if they hadn't switched boats.

"It's all about anchoring out if you want to cruise on the cheap," insists Rich. "That mantra has kept us cruising in comfort for about what it would cost us to live under a bridge back in California!"

In addition to eschewing marinas, the

Boren family also made a point of hauling out at boatyards that would allow them to work on their own boat. "That



COURTESY THIRD DAY

"Amy and Jason loved cruising and didn't mind leaving their old lives behind," says Rich. It certainly is a good way to bring a family closer.

saved us about \$1,000," Rich estimates, "and the kids even pitched in."

Even with saving so much on their haul-out, that expense — along with some unexpected repairs — drove their monthly average up for this year, but Rich says that if those costs are subtracted, they're continuing to hit their \$1,000 per month budget.

As for the new boat, Rich says the costs associated with upgrading in size have been minor, but the upgrade in comfort for everyone onboard has been worth every penny. "Lori and I laugh at the size and scale of our new boat compared to the Pearson, but it sure has made living aboard with the kids easier."

Bill and Judy Rouse of Houston,

THE COST OF CRUISING



COURTESY THIRD DAY

Meri Faulkner of 'Hotspur' (left) and Lori Boren head into town on a cruiser's fuel run in Bahia de Los Angeles, Mexico. Cheaper than a taxi!

Texas, have a slightly different perspective from the Borens on what defines comfort aboard their Amel Super Maramu *BeBe*. "Cruising can certainly be done for less, but not in comfort," says Judy. "If we were cruising in a manner that was more like camping on the water, there is no way we'd still be enjoying it five years later."

Their preference for comfort is reflected in their very precise accounting of every penny spent since the start of their adventure in May '06. "Unlike every other cruiser we've met, we really do track every single penny," Judy insists. "Even if we buy a small bottle of water, that 50-cent item is recorded into a book we keep at the nav table."

With a work history in accounting,

Third Day's Cost of Cruising, 2011 (thru May):

	Jan	Feb	Mar	Apr	May	Totals	Avg
groceries/provisions	217.17	149.08	236.42	356.00	253.88	1212.55	242.51
sundries	0	0	4.17	14.00	12.77	30.94	6.19
fuel/propane	445.97	44.67	41.25	59.13	155.76	746.78	149.35
restaurants/food carts	124.32	98.33	129.17	64.00	54.53	470.35	94.07
alcohol	3.75	0	6.25	12.00	0	21.95	4.39
taxi/bus	28.13	31.36	40.83	35.00	39.93	175.28	35.05
clothes	0	30.51	20.00	22.61	0	73.12	14.62
marina/mooring fees	46.42	46.42	46.42	68.18	56.38	263.82	52.76
phone/email	40.65	40.65	40.65	40.65	114.52	277.12	55.42
boat maintenance	13.61	13.33	2217.58	0	0	2244.52	448.90
boat repairs	0	272.70	168.07	186.96	1225.28	1853.08	370.61
spares/equipment	0	0	0	0	103.18	103.18	20.36
inland excursions	79.67	41.67	0	0	0	118.34	23.67
laundry	4.17	10.00	0	0	0	14.17	2.83
souvenirs/gifts	29.88	16.67	0	0	34.19	80.74	16.15
education	0	0	0	57.00	18.91	75.91	15.18
tips	15.00	1.67	5.00	15.00	0.91	37.58	7.51
boat insurance	133.00	133.00	133.00	133.00	118.00	650.00	130.00
medical	0	46.50	3.95	0	643.27	693.72	138.74
monthly totals	1178.73	976.62	3092.75	1063.53	2831.52	9143.15	1828.63

Notes:

March: Haul-out & bottom job

May: \$100 for used dinghy

Boat repairs — Feb: new exchangers; Mar: outboard prop; Apr: rebuilt starter; May: transmission rebuild

such practices come naturally to Judy, who also goes so far as to calculate the currency conversion based on the rate at which they exchanged their money. "By the way, doing this provides *glaring* proof of the continual devaluation of the dollar worldwide."

At the end of every month, Judy to-

tals up all the daily expenditures and organizes them by category. "Most of the questions we get about our costs concern our 'Miscellaneous Boat Supplies' category," Judy notes. Indeed, a quick look at the table below — about halfway down — shows that the Rouses have spent 19% of their total expenditures over the past five years on boat supplies!

"That category contains every item purchased to clean the boat or to maintain anything in or on the boat, except for maintenance performed during haul-outs," explains Judy. "When you write down every expense, those little items that tend to get forgotten really do add up!"

If a \$500 monthly budget seems a little skimpy to you, but \$4,000 a month is a pipe dream, don't worry. Tons of families cruise comfortably — their own personal version of "comfort" — in the \$1,500-2,500 range. Just expect that your first year out will see you spending more as you adjust to the lifestyle, and budget accordingly. Before long, you'll find out exactly how much cruising costs *you* — and that's what you really wanted to know in the first place.

— **latitude/ladonna**

BeBe's Cost of Cruising, 2006-2010:

	5/06-4/07	5/07-4/08	5/08-4/09	5/09-4/10	Totals	%
	<i>E. Carib</i>	<i>E. Carib/VZ/ABC</i>	<i>S.Pac-NZ</i>	<i>Vanuatu-Malaysia</i>		
communication	575.20	561.57	873.48	475.38	2485.63	1.3
groceries	7091.46	6731.60	4192.69	5938.79	23,954.54	12.4
entertainment	2823.91	4128.15	2991.25	3400.78	13,344.09	6.9
transportation	521.73	1349.08	793.21	1002.39	3666.41	1.9
household & clothes	2851.26	2802.58	2483.41	3669.66	11,806.91	6.1
fuel/propane	2264.35	1371.25	2751.02	1683.34	8069.96	4.2
marina/mooring fees	4299.78	6558.20	3293.39	4060.74	18,212.11	9.5
customs fees	742.71	998.51	1903.45	1335.82	4980.49	2.6
misc. boat supplies	14,672.54	9784.78	6161.55	5976.03	36,594.90	19.0
other	984.49	1871.14	260.19	325.00	3440.82	1.8
laundry	139.68	145.42	108.81	183.64	577.55	0.3
tours/sightseeing	4011.00	0	4744.13	5777.71	14,532.84	7.5
misc & trips home	1598.39	352.72	0	3547.56	5498.67	2.9
panama canal	0	1209.00	0	0	1209.00	0.6
sailmail & weather	609.00	255.00	367.08	505.90	1736.98	0.9
charts/guides/flags	30.00	404.78	328.20	(188.31)	574.67	0.3
medical	6534.33	5787.30	1421.16	778.37	14,521.16	7.5
boat insurance	5432.49	5614.95	5588.88	5745.33	22,381.65	11.6
gifts	408.74	1269.70	1676.20	1714.73	5069.37	2.6
annual totals	55,591.06	51,195.73	39,938.10	45,932.86	192,657.75	100
haulouts	6415.97	4328.37	4755.94	0	15,500.28	8.1
amel spare parts	2513.99	1452.17	495.53	0	4461.69	2.3
grand totals	64,521.02	56,976.27	45,189.57	45,932.86	212,619.72	110.4

Notes:

Haul-outs are counted separately from monthly expenses

Sold Pacific guides/charts in fourth year



COURTESY BEBE

Judy Rouse counts every penny spent.

"You really *are* going to file the protest, aren't you?" My crew was adamant. "Those idiots hit us right in the stern and could have caused a serious collision. We can't let them get away with that kind of stuff on the course."

"Well, I don't know," I hemmed. "It's only a beer can race. I'll have a talk with their skipper, but I really don't want to waste the whole evening in a protest hearing. It's only a beer can race."

It was my crew who had hailed "protest" and put up the red flag, and now he was insisting that we follow through and see that maritime justice would be served. Even if it meant missing most of the post-race socializing and all of dinner. I had gone that route before, and there was no upside in it for us. Maybe my 'protestosterone level' was getting low, as another one of my crew suggested, because by the time we sat down for dinner I had pretty much decided not to file. Although everyone who had seen the collision was talking about it, and everyone had a different opinion.

"You probably tacked too close," suggested one racer who was a few lengths behind us at the mark. "And the burden of proof is on you to prove you didn't."

"That boat ran right up your transom!" insisted another witness. "He was overtaking and had to keep clear."

"I didn't see it, but I think you've got him DSQd for sure if you file the protest, and I'll be a witness," volunteered another racer between gulps of beer.

"Room, please! Room at the table!" hollered a female voice coming up from behind. It was Lee Helm, naval architecture grad student, squeezing in between me and my mainsheet trimmer. Her hair was still wet and she smelled a little like neoprene and Bay water — a telltale sign that she had been windsurfing instead of studying for the exam that she had used as a pretext for not being available to crew for me that night. She pulled up a chair, and before I could even introduce her to my crew, she went to work.

"Okay when did you, like, display the

flag?" she demanded.

"Immediately!" replied my crew. "I keep a protest flag in my PFD pocket. I was in the back of the boat, so after we rounded I tied it to the backstay. I used two rolling hitches to keep the luff taut."

"And did you hail?"

"Yes! Even before the flag went up, right when they hit us from behind. They had plenty of room to keep clear after our tack was complete."

"Let's use this spoon for your boat, and

roll from my plate and positioned it where the mark would be. "And I left a little extra room to make sure we could round."

"So did you go below close-hauled to get to the mark?"

"I never cranked the jib all the way in on the new tack," volunteered the jib trimmer. "I'd say were off the wind by, maybe, 10 or 20 degrees after we tacked."

"Now position the boats when you first crossed a close-hauled course after crossing head-to-wind," instructed Lee.

"Right," I said. "That's when the tack really ends, isn't it? Well, that's even better for us. We were here and the other boat had all the room they needed to avoid us. There were no other boats to windward. But instead he just came up a little bit, then bumped our stern and started yelling rule numbers at us."

"I totally almost forgot," Lee exclaimed as she handed me a sheet of paper with some freehand scribbles on it. "Here's the written protest, initiated by the RC. It names you and the other boat."

I couldn't read a word of it without my reading glasses. It seemed unusual for the race committee to willingly initiate a protest, but I vaguely remembered that it was legal, provided of course that the RC is staffed by certified masochists.

"I think I have your side of the incident pretty well defined," said Lee. "Now if you can, show me which table the other crew is at, I'll go data mine their side, then look for other people who saw it happen. Your boat can send a rep with me if you want."

"Wait a minute. What time is the hearing? I need to line up my

AMENDMENT TO THE SAILING INSTRUCTIONS

Rolling Mediation Hearings:

Unless there is serious damage or injury, protest hearings will be conducted according to the Rolling Mediation Hearing protocol:

The hearing may begin immediately after the RC has reason to believe that a written protest will be filed.

The hearing may adjourn and resume as necessary.

The location of the hearing may move about anywhere within the clubhouse during the course of the hearing.

Applicable sections of Racing Rules of Sailing, Part 5, are modified as follows:

RRS 61.2 (Protest Contents) is replaced with:

"A protest shall be in writing and need only contain sufficient information to identify the boats involved and the approximate time and place of the incident."

RRS 63.2 (Time and Place of Hearings), 63.3 (Right to be Present) and 63.4 (Interested Party) are deleted.

RRS 63.6 (Taking Evidence and Finding Facts) is replaced with:

"The protest committee shall take the evidence of all readily available parties to the hearing and of all readily available witnesses and other evidence it considers necessary. Any person who saw the incident may give evidence. At the discretion of the protest committee, any party to the hearing or any other person may question any person who gives evidence. The committee shall then find the facts and base its decision on them."

In-House Appeal:

After the decision is announced, a party to the hearing may, upon paying a \$120 fee, request that the decision be voided and the hearing repeated in accordance with the unmodified RRS and YRA standing sailing instructions, which call for a formal hearing on the second Monday following the race. No members of the original Rolling Mediation Hearing protest committee may participate in the hearing of an in-house appeal.

this fork for the other boat," Lee said as she moved some plates to clear a space for the two utensils. "Max, show me where the boats were when you crossed head-to-wind during your tack."

I added a knife to show wind direction, and positioned the boats as best as I remembered. My crew adjusted them a little, and I moved them back, but we finally agreed on the geometry.

"Now position the boats when your tack was complete."

I moved the spoon to represent my boat on course to the mark.

"That's below close-hauled, according to your wind arrow. Did you mean to show that you, like, overstood by that much?"

"We were right at the mark, maybe only two lengths away when we came out of the tack," I explained as I removed a dinner



witnesses! Who's on the Protest Committee? Who's on first?"

"Who's on first?" she repeated.

"I don't know!" I said, starting to get confused.

"Third base," she answered. "It's a rolling mediation hearing, Max. The PC is moi. We're having the hearing right now."

"Can they do that?" I asked, turning to my rules-expert crew.

Lee handed him another sheet of paper titled 'Amendment to Sailing Instructions, Rolling Mediation Hearings' that set out the guidelines for this procedure.

"It's the new approach to protest resolution for the beer can races," Lee explained. "I mean, it seems that everyone wants to talk about right-of-way incidents on the course, but no one ever wants to bother with a protest or a formal hearing. But, like, with the Rolling Mediation Hearing, the racers don't have to bother with anything. They can still talk about it all night. The Protest Committee, usually just one person, runs around the bar and the dining room interviewing everyone

involved, and the witnesses, and makes a decision."

"But that's a perversion of due process!" complained my crew.

"If you think we get the wrong result you can still escalate to a regular-format hearing a week from Monday," she said.

"For a \$120 filing fee!" my crew moaned, having just read all the way down to the bottom of the amendment.

"Who's on first?"

"For sure," grinned Lee. "That's to cover the three dinners for the Committee at the fancy upscale waterfront restaurant. Works for us starving grad students. I gotta go finish the hearing. I still have to talk to the other boat and to witnesses. You can tag along."

But before she could leave we were

interrupted by another sailor rushing up to Lee and thrusting a tablet computer practically in her face.

"Lee, ya gotta see this. Happened today . . ."

He swiped his fingers across the screen in some special gesture and a video clip started to play. It was an America's Cup catamaran, one of the new 45-ft one-designs, sailing at high speed. Then it executed a spectacular pitchpole.

"Crash. And. Burn," observed Lee. "That's what happens when you multiply all the hydrodynamic and aerodynamic thrust, lift and side forces, and go really fast, but still rely on hydrostatics for pitch stability. I mean, that's why there's a 'static' in 'hydrostatics.' The pitch restoring force is the same at 30 knots as it is at zero knots. But all the other forces go nuclear. So duh. Of course these things are going to be, like, pitchpole city . . ."

"How else are you going to resist pitchpoling?" asked my crew.

"You have a big airfoil wing pushing the boat, you have deep foils resisting side force and also adding some upward lift, you have foils steering, you have really,



Beer cans are laid-back affairs but only to a certain point — and collisions are often that point.

MAX EBB

really high speed so all the forces are huge, and then you rely on plain old-fashioned static displacement of the bows to keep the thing from going down the mine."

"So Lee, do you think that the big cats were a bad choice?"

"Maybe not for the 45s, if they want to make it like NASCAR. But for San Francisco Bay, they should probably add another 10 or 15 feet to the middle of each hull to make them AC55s or 60s. It wouldn't be such a hard retrofit. But for the 72s I think it's a bad choice to limit the number of foils. Pitch needs to be controlled by an active foil at the bow or the stern. And as long as they're going that fast, they might as well be fully hydrofoil-supported while we're at it. Fully foil-borne with three-axis control would be really cool and a lot safer."

"But no crash-and-burn without the pitchpoles," noted another crew.

"**B**ack to business," said Lee. "Do you know where the possible witnesses are sitting?"

I pointed out the tables with crews who

said they saw what happened, and decided to stay at my seat and finish dinner. My rules-expert crew, however, left his dinner half-finished and went with Lee to uphold our honor for the remainder of the rolling hearing.

"But that's a perversion of due process!"

"I think we're on pretty safe ground," he said when he returned to our table 15 minutes later. "Their diagram agrees perfectly with ours, and it shows that they had all the room they needed to avoid us after we first came to a close-hauled course after the tack."

We watched Lee move from table to table, and if the whole dining room wasn't talking about the incident before the process began, they all were certainly talking

about it by the time she was done.

"We have a decision," she announced over the dining room P.A. just before the race results were scheduled to be announced. "Max is, like, DSQd for infringing Racing Rule of Sailing 18.3a, which states, in part, that a boat that tacks within the three-length zone shall not cause another boat to sail above close-hauled to keep clear. We, er, I mean I, find that the boat astern came up to close-hauled, and to avoid contact, it would have had to come up higher."

"Does the rule really say that?" I asked my crew.

He flipped through his rule book. "I guess it does," he admitted. "It's a stricter standard than when you tack in front of another boat in open water, when it doesn't matter what course they have to assume in order to keep clear. At the mark, if they have to go up above close-hauled, I guess you're out. I think if we do the in-house appeal we can get them thrown out, too, for a rule 14 violation. But it'll cost \$120 bucks."

"It's only a beer can race . . ."

— max ebb



FREEDOM
FROM HIGH MAINTENANCE COSTS

SAN FRANCISCO BOAT WORKS

835 Terry A. François St., San Francisco, CA 94158
(415) 626-3275 Fax (415) 626-9172

CALL US - SEVEN DAYS A WEEK!

Be our guest for lunch at the historic Ramp Restaurant*

*Some restrictions apply



Interlux
yachtpaint.com

**SUMMER HEAT
MEANS
HOT
DISCOUNTS!**

And we're always available!

**REQUEST A HAUL-OUT
ONLINE!**

**ORDER PARTS
ONLINE!**

www.sfboatworks.com



Mark your calendars for these upcoming events at South Beach Yacht Club!

J/120 and IRC South Beach Invitational



PETER LYONS/WWW.LYONSIMAGING.COM

July 16-17 • South Beach Yacht Club
Pier 40 The Embarcadero, San Francisco

Open to all J/120s and IRC yachts.

Two days of buoy racing on San Francisco Bay in the flat waters and steady winds south of the Bay Bridge.

Saturday night post-race beer and no-host bar, and dinner menu

South Beach Yacht Club & Benicia Yacht Club
are proud to present the 23rd Annual

JAZZ CUP

SAN FRANCISCO TO BENICIA

MARGARET FAGO



Saturday, September 3

Labor Day Weekend

*Best in
Downwind
Racing*

Fantastic post-race party and overnight berthing • CalTrans says no bridge closure this year!

www.southbeachyachtclub.org • (415) 495-2295 • RearCommodore@southbeachyachtclub.org

WINDEX INNOVATION

WINDEX 15

Now with
Bird-Proof Spike!



Why Windex 15 is the
choice for most sailors:

- 15" wind vane (38 cm)
- Sapphire suspension bearing
- Adjustable tacking arms with tabs
- Vane and tabs feature reflectors for high visibility day and night
- Weighs just 3.9 ounces (111 grams)
- Stands 12.75" tall (32 cm)
- Bird-proof spike extends another 10" (24 cm) above vane to discourage birds from landing.

The versatile J-Base can be
purchased for Windex 15 to
allow top or side mounting.

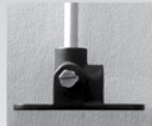

Contact us for your FREE copy
of the latest

DAVIS
catalog.

Davis Instruments 3465 Diablo Ave., Hayward, CA 94545 U.S.A.
Phone 800-678-3669 • Fax 510-670-0589 • E-Mail info@davisnet.com

www.davisnet.com

The Cure for the Common Career
Degree and certificate programs in
boatbuilding, yacht design and systems.



The Landing School
www.landingschool.edu

THE RACING

June was a whopper for racing action. We wrap up the month's racing action starting with the **Coastal Cup**, then move on to **Summer Sailstice**, **Spinnaker Cup**, and **18-ft Skiffs**. From there we catch up on the **Delta Ditch Run**, the **Spring Invitational**, **Woodies Invitational**, the **Sperry Top-sider NOOD Regatta**, and **Ullman Sails Long Beach Race Week**. Finally, we take a quick look at the **Etchells Worlds** and **Sausalito Hobie Regatta**. Enjoy!

Coastal Cup

It didn't take long for the 11 finishers in the Encinal YC's Coastal Cup to get down the coast. The first of June 15's starters to reach the finish off the west end of Catalina Island, Steve Stroub's Tiburon-based SC 37 *Tiburon* finished two days later at 6:11 a.m.



Steve Stroub

in 10-12 knots of breeze, only 45 hours after starting. But that 10-12 knots was a far cry from the 30-plus they saw throughout the race. "These were the biggest waves I've ever surfed, apart from in the Molokai Channel," said *Tiburon* navigator Will Paxton. "I didn't think she could do it, but she just rampaged. We were seeing sustained surfs of 20-plus knots and even put up a 23.5-knot top speed on the GPS. The bow wave was back at the primary winches!"

Paxton gave credit to a an old-style 77-sq-meter J/105 kite they brought along as a backup. After tearing their main four hours into the race, *Tiburon* sailed with a reef and that kite all the way to the finish.

"About a week before the race, I was thinking that the last time I did this race, I had to drop out because we blew up all of our kites," Stroub said. "So I called up the guy who bought my old J/105, and asked

Okay, so this isn't the Coastal Cup, but Steve Stroub's SC 37 'Tiburon' wasn't exactly available for photos while smashing down the coast.

him if we could buy back the kite. It's a 1.5-oz kite that I'd bought right before the rule changed (to allow larger spinnakers) and had only been used once. That sail rocked! It was about six feet short on the hoist and two feet short on the tack, and it was perfect."

But still, it wasn't smooth sailing for the 'sharks.' Fifty miles out from the finish, the steering system exploded, and they spent 45 minutes on their side, hove-to — or in certain cases, dry-heaving — while Paxton rebuilt the steering system.

"It was the epic downhill, heavy air, gear-busting race it's supposed to be," Paxton said.

Rufus Sjoberg and Dylan Benjamin aboard the former's 11 Meter *Skiff*sailingfoundation.org were not far behind, but came up short in their bid to unseat *Tiburon*. They settled for second overall, with another four hours of corrected time. Rounding out the podium was Brack Duker's SC 70 *Holua*.

Elapsed time honors went to Andrew McCorquodale's Open 60 *O Canada* which, like many of the boats, found pressure well offshore — *Tiburon* got as far as 120 miles off the coast at one point. *O Canada* covered the 360-mile course in 36h, 24m, 26s.

The big breeze took its toll on the fleet — 16 boats had started. But more striking was the fact that there were only 16 boats to begin with. According to Encinal YC Vice Commodore Victor Early, a combination of circumstances meant that no local option for the Safety At Sea Seminar — a requirement for 40% of the crew as the race is an offshore Category 2 event — was available beforehand.

"Our local instructor retired from doing the seminar," Early said. "US Sailing didn't select a new one until three months before the start, which didn't leave us enough time to promote it to the point where we could fill the class."

Filling the class is important if you're going to sponsor the seminar, as all the costs are incurred by the sponsor, and it's not inexpensive. As it was, the next available class wasn't scheduled



ERIK SIMONSON/WWW.H2OSHOTS.COM

until after the race.

We have to think that the club's new m.o. of switching between Catalina Island and Santa Barbara in alternate years also having an effect. Race veterans have told us that sailing the race in a trailerable boat is much easier when going to Santa Barbara than Catalina. For the latter, most outboard-powered smaller boats just hang a left after the finish, faced with an additional 25-mile sail and/or motor over to the mainland — if they don't sail the 18 miles down to Avalon first — often in little or no breeze. The island has its own eddy named after it, and it's typical to get very little breeze in the mornings, which can mean a complete restart after a downwind smash fest.

Although the leg into Santa Barbara after reaching Pt. Conception can be equally light, the logistics are a lot simpler.

Once in Santa Barbara, all the boats have to do is haul out, pack up, attend the trophies (or not) and get home. One racer posed a very good question.



ERIK SIMONSON/WWW.H2OSHOTS.COM



'Walloping Swede' rolls over a Moore 24 at the St. Francis YC-hosted Sperry Top-sider NOOD regatta. You'll find a wrap-up and results on p. 126.

"If we're finishing at an imaginary spot, then why can't it be off Pt. Conception?" the sailor said.

Another criticism leveled at this year's race was the fact that it started at 9:30 a.m. Not only did this mean ridiculously early dock times for people who ostensibly were cramming hard at work and home the night before, in order to be able to get out of town, it meant that they were starting at max flood! It turned out the breeze was pretty darn light, and the result was a complete restart at Mile Rock.

"We almost had to turn our engine on at one point just to keep from going up on the rocks," Paxton said of the early portion of Tiburon's race.

ENCINAL YC COASTAL CUP (6/15)

OVERALL — 1) **Tiburon**, SC 37, Steve Stroub; 2) **Skiffsailingfoundation.org**, 11 Meter, Rufus Sjoberg; 3) **Holua**, SC 70, Brack Duker; 4) **Bolt**, N/M 55, Craig Reynolds; 5) **Stealth Chicken**, Per-

ry 56, Tim Beatty. (16 boats)

PHRF 1-45 — 1) **Tiburon**; 2) **Skiffsailingfoundation.org**; 2) **Shenanigans**, J/120, Gary Winton. (3 boats)

PHRF 46+ — 1) **Peregrine**, Catalina 38, Steve Smolinskic. (3 boats, 1 finisher)

PHRF ≤ 0 — 1) **Holua**; 2) **Bolt**; 3) **Stealth Chicken**. (6 boats)

Complete results at: www.encinal.org

Summer Sailstice

The Summer Sailstice and YRA Spring 3 commemorated the Northern Hemisphere's celebration of sailing with chamber of commerce-like conditions on June 18. Thirty-six boats spread over three one design and four PHRF divisions enjoyed an absolutely stunning day on the Bay. Breeze that ranged from 10 to 20 knots, a ripping flood that kept the chop to a minimum, and pre-

dominately sunny skies made the sailing just about as perfect as you can get.

In the end, Gerry Brown's all-conquering Farr 38 *Mintaka 4* sailed away with the Summer Sailstice Perpetual Trophy and HDA G honors, while George Ellison's Schumacher 30 *Shameless* was tops among the SF 30s, Larry Baskin's Catalina 34.5 *Sea Spirit* took the HDA K honors and Dan Alvarez' JS 9000 *JetStream* carried the Sportboat division.

Bartz Schneider's *Expeditious* was the top Express 37, Kris Youngberg's *Tenacious* took the Islander 36 honors, and Tom Montoya's *Meliki* won the Santana 22 division by a mere two seconds!

SUMMER SAILSTICE AND YRA #3 (6/18)

HDA G (PHRF ≤ 123) — 1) **Minataka 4**, Farr 38, Gerry Brown; 2) **Ahi**, Santana 35, Andy Newell; 3) **Red Cloud**, Farr 36 mod., Don Ahrens. (10 boats)

SF 30 — 1) **Shameless**, Schumacher 30, George Ellison; 2) **Elusive**, Olson 911S, John Schoenecker; 3) **Gammon**, Tartan 10, Jeff Hutter. (4 boats)

HDA K (PHRF 126+) — 1) **Sea Spirit**, Catalina 34.5, Larry Baskin; 2) **Mimicat**, Hinckley 38, Robert Long; 3) **Truant**, Swan 38, Laurie Bolard/Hilary Lowe. (6 boats)

HDA SPORTBOAT — 1) **JetStream**, JS 9000, Dan Alvarez; 2) **Jazzy**, 1D35, Bob Turnbull; 3) **Centomiglia**, FT 10, Fabio Maino. (3 boats)

EXPRESS 37 — 1) **Expeditious**, Bartz Schneider; 2) **Stewball**, Bob Harford; 3) **Golden Moon**, Kame Richards. (4 boats)

ISLANDER 36 — 1) **Tenacious**, Kris Youngberg; 2) **Windwalker**, Richard Shoenhair/Greg Gilliom; 3) **Luna Sea**, Daniel Knox. (4 boats)

SANTANA 22 — 1) **Meliki**, Tom Montoya; 2) **Oreo**, Bobby Renz; 3) **Santa Maria**, Chris Giovacchini. (4 boats)

Complete results at www.yra.org.

Spinnaker Cup

The Monterey Peninsula and San

Brack Duker's SC 70 'Holua' finds a maelstrom off Land's End shortly after the start of the Encinal YC's Coastal Cup. Amazingly there wasn't much wind when this photo was taken.



THE RACING



LATITUDE/SUTTER



ALL PHOTOS LATITUDE/ROB EXCEPT WHERE NOTED

Clockwise from top-left — Fabio Maino's FT 10 'Centomiglia' enjoying champagne conditions during the YRA's Summer Sailstice race; in case you were wondering, this is what it looks like on the other side of the world in Lyttelton, New Zealand; 'Oreo' blasts downwind, weight-forward; 'The Catalina 42 'Tesa' looking pretty; Dan Alvarez' JS 9000 'JetStream' lit up headed down the Central Bay; George Ellison's Schumacher 30 'Shameless' powers upwind; a ripping flood had everyone giving Harding a wide berth; one thing the new-look America's Cup is missing . . . bold color; Tom Montoya's 'Meliki' won the Santana 22 division.

Francisco YCs' Spinnaker Cup brought out a quality fleet of 45 boats for what turned out to be an extremely pleasant trip down the coast on May 27. Although the fleet was greeted by drizzle at the 11 a.m. start, the sun followed not long after, and by the time the big boats passed Montara, the breeze joined in the fun as well. Surfing conditions kicked in as many boats reached Pigeon Point, and continued all the way across Monterey Bay.

Andy Costello's J/125 *Double Trouble* set the corrected time pace — with the help of navigator Trevor Baylis, Patrick Whitmarsh, Mark Breen and Gilles Combrison — finishing third on elapsed time and first overall on corrected. Charles James' *Bloom County* took the honors in Class B, while Frank Sloatman's J/111 *Invisible Hand* was tops in Class C, finishing less than a minute clear of Mark Dowdy's Express 37 *Eclipse*. Nicholas Sands' Sa-

bre 402 *Escapade* took Class D. Nathan Bossett's Express 27 *Elise* was the top singlehander and Jim Brainard's J35C *Brainwaves* was the top doublehanded boat.

Elapsed-time honors went to Bill Turpin's R/P 77 *Akela*, even though it failed to beat its record (7, 11m, 6s) from last year by about 40 minutes.



The division breakdowns this year were interesting to say the least, determined by rating and displacement/length ratios. While smart from the standpoint of giving the less downwind-oriented boats a better chance at some hardware, an unintended consequence was that some of the divisions were large relative to others, and likewise the rating bands. For instance, a light boat grouping, Division B, had five boats that ranged in downwind rating from an Olson 40 at 27, to a Moore 24 at 123! Division C, a heavier boat grouping

had 16 boats, ranging from Steve Stroub's SC 37 *Tiburon* at 6, to Warren Pelz' SC 27 *Rocinante* at 102, plus Express 27s, 37s, and oddly enough, a SC 40 that for all intents and purposes is about as close to an Olson 40 as you can come without actually being an Olson 40. Hopefully, this will get sorted next year when the race rides a wave of two good weather years in a row.

SPINNAKER CUP MONTEREY PENINSULA YC/ SFYC (5/27)

OVERALL — 1) **Double Trouble**, J/125, Andy Costello; 2) **War Pony**, Farr 36, Mark Howe; 3) In-

visible **Hand**, J/111, Frank Sloodman; 4) **Eclipse**, Express 37, Mark Dowdy; 5) **Serena**, Thompson 38, Dave Kuettel; 6) **Bloom County**, Mancebo 31, Charles James/Jon Stewart; 7) **Criminal Mischief**, R/P 45, Chip Megeath; 8) **Bustin' Loose**, Sydney 38, Jeff Pulford; 9) **Scorpio**, Wylie 42, John Siegel; 10) **Quiver**, N/M 36, Jeff McCord. (45 boats)

DIVISION A — 1) **Double Trouble**; 2) **War Pony**; 3) **Serena**. (11 boats)

DIVISION B — 1) **Bloom County**; 2) **For Pete's Sake**, Ultimate 24, Peter Cook; 3) **Spellbound**, Olson 40, Bob Gardiner. (5 boats)

DIVISION C — 1) **Invisible Hand**; 2) **Eclipse**, Express 37, Mark Dowdy; 3) **Bustin' Loose**. (16 boats)

DIVISION D — 1) **Escapade**, Catalina 402,

THE RACING

Nick Sands; 2) **Irish Lady**, Catalina 42, Mike & Pat Mahoney; 3) **Redhead**, Cal 40, Walter Smith. (5 boats)

DIVISION E — **Elise**, Express 27, Nathan Bossett; 2) **Brainwaves**, J35C, Jim Brainard; 3) **Plus Sixteen**, Olson 911, Paul Disario. (7 boats)

SINGLEHANDED — 1) **Elise**; 2) **S' Moore**, Moore 24, Wayne Crutcher; 3) **Temerity**, Olson 34, David Nabors. (4 boats)

DOUBLEHANDED — 1) **Brainwaves**; 2) **Plus Sixteen**; 3) **Pegasus**, J/35, Marc Sykes. (3 boats)

Complete results at: www.sfyc.org

18-ft Skiffs

The Golden Gate YC hosted the first of what it hopes will

be a series of regattas for the Bay's 18-ft Skiff sailors on June 4-5. Thanks to the club's efforts to work with the National Park Service, Aquatic Park served as a first-rate staging area for the event. The constant foot traffic provided a steady stream of curious non-sailors asking about the freakish-looking boats as the three-person teams rigged and derigged. With a starting line right off the entrance to Aquatic Park, the spectating was easy, too. After five races, JV Gilmour, Matt Van Rensselaer and helmsman Brian Maloof came out on top of the five-boat fleet.

"My life is never better than when I'm sailing one of these," Gilmour, who although he maintains the boat, handed off the helming duties to the PYSF's Maloof. In second, just one point back after a throwout were Morgan Gutenkunst, Kevin Richards and Trevor Bozina.

Weird weather that saw a light southerly predominate on Saturday, and a light southwesterly on Sunday resulted

The St. Francis YC's Woodies Invitational brought out the customary large fleet of some of the Bay's hardest-raced boats on June 4-5.

in a rare chance to race in light air on the Bay.

A fresh face on the 18-footer scene, Richmond YC's Joe Carter, just 17 years of age, got to spent the weekend sailing with some of the better 18-footer sailors on the Bay, Dan Malpas (on Saturday) and Pat Whitmarsh (on Sunday).

"Pat told me, there comes a time in every boy's life when he has to become a man," said. Carter, who's been sailing the boats regularly over at Richmond YC recently. Shortly thereafter, Whitmarsh handed Carter — who barely has the physique for a 29er — the tiller to steer his first 18-ft races, and the result was a 1-2 that launched them onto the podium.

The regatta also marked the debut of a new *Chad's Angels*. Skipper Mallory McCollum-Bozina and Katie Love teamed up with Skiff Sailing Foundation president(?) czar(?) spiritual advisor(?) Chad Freitas to race the recently re-habbed and pink-Awlgripped League boat which replaces the aged Grand Prix boat that McCollum-Bozina and Love sailed with Yvonne Galvez at last year's St. Francis regatta.

The regatta was organized by the Golden Gate YC's Dave Santori and Ellen Hoke, who have made it clear to the skiffies that they want to host more of these events in the future to help fill out the fleet's schedule, which so far has been limited to one or two events per year.

GGYC 18-ft SKIFF REGATTA (5/14-15)

18-FOOTERS— 1) **Red Boat**, JV Gilmour, 7 points; 2) **DCM Enterprises**, Morgan Gutenkunst, 8; 3) **Team Harken**, Pat Whitmarsh, 9. (5 boats)

Complete results at: www.ggyc.com

Delta Ditch Run

As with the 18-ft Skiffs, the weather's toll on the Delta Ditch Run on June 4 was dramatic. Only 22 of the 89 monohull racing entries were able to complete what turned out to be an upwind slog that was even gnarlier than last year's.

After a rainy, light-air start and slow crossing of San Pablo Bay, things started getting interesting for the fleet as it passed the Benicia Bridge. The forecast 10 knots-or-less out of the southeast turned into 18 to 30 knots from the east!



Joe Carter

LATITUDE/ROB



ALL PHOTOS ELLEN HOKE

Only two multihulls finished, Drew Scott's F-27 *Papillon*, and Jason Deal's Nacra 6.0 *Kitty Litter*. Three boats from the six-boat Cruise division also finished, but overall honors went to Mark Thomas' SC 37 *Wildcard*, which finished just after 9 p.m. to take the elapsed time honors as well.

Just a day after putting smiles on the faces of four high school-age winners of a San Francisco Architectural Foundation competition to design a student pavilion for America's Cup 34, Peter Stoneberg's Formula 40 *Shadow* lost the tip of her rig to a pitchpole.

Breaking with our common format, we're listing all of the monohull finishers in the results, as division breakdowns would be largely superfluous, and everyone who stuck this one out deserves a mention.

DELTA DTICH RUN STOCKTON SC (6/4)

MONOHULL — 1) **Wildcard**, SC 37, Mark & Anne Thomas; 2) **TBD**, Melges 32, Gregory Dyer; 3) **Dark Helmet**, Moore 24, Bill Erkelens; 4) **Stretch**, Hobie 33, Mark Schipper; 5) **E.T.**, Antrim 27, Tony English; 6) **Wild Rumpus**, SC 27, Stephanie Schwenk; 7) **Waves Ohes**, Moore 24, Matt McQueen; 8) **Moorigami**, Moore 24, John Siegel; 9) **Paddy Wagon**, Moore 24, Sean McBurney; 10) **Flying Tiger**, Moore 24, Vaughn Seifers; 11) **Marrakesh**, Express 34, Craig Perez; 12) **El Raton**, Express 27, Ray Lotto; 13) **Magic Bus**, Express 27, Paul Deeds; 14) **Ahi**, Santana 35, Andy Newell; 15) **Peaches**, Express 27, John Rivlin; 16) **Topper II**, Moore 24, Conrad Holbrook; 17) **Great White**, Express 27, Rachel Fogel; 18) **Dianne**, Express 27, Steve Katzman; 19) **Bad Hare Day**, Wylie wabbit, Erik Menzel; 20) **Ay Caliente!**, Beneteau 36.7,



SERGEI ZAVARIN



13 Folkboats sailed a four-race series that Dave Wilson's *Windansea* won with straight bullets.

The Knarrs also sailed four races, with Chris Perkins' *Three Boys and a Girl* besting 13 other boats for the win. The six IODs sailed a five-race series with Rich Pearce's *Fjaer* scoring a 2-2-1-1-2 for the win.

St.FYC WOODIES INVITATIONAL (6/4-5)

BIRD — 1) **Robin**, Cissy Kirane, 2 points; 2) **Skylark**, James Joseph, 5; 3) **Widgeon**, David Cobb, 6. (4 boats)

FOLKBOAT — 1) **Windansea**, Dave Wilson, 4 points; 2) **Polperro**, Pepter Jeal, 16; 3) **Elsie**, Michael Goebel, 19. (13 boats)

IOD — 1) **Fjaer**, Mark & Rich Pearce, 8 points; 2) **Xarifa**, Paul Manning, 9; 3) **La Paloma**, Jim Hennefer, 19. (6 boats)

KNARR — 1) **Three Boys and a Girl**, Chris Perkins, 10; 2) **Sophia**, Tom Reed, 17; 3) **Snaps**, Knud Wibroe, 21. (14 boats)

Complete results at: www.stfyc.org

OYRA Results

FULL CREW FARALLONES (6/11)

OVERALL — 1) **California Condor**, Antrim Class 40, Buzz Blackett; 2) **Kokopelli**², SC 52T, Lani Spund; 3) **Ocelot**, Fox 44, Kevin Flanigan/Greg Nelsen; 4) **War Pony**, Farr 36, Mark Howe; 5) **Dark & Stormy**, 1D35, Jonathon Hunt. (42 boats)

PHRO 1A — 1) **California Condor**; 2) **Kokopelli**²; 3) **Ocelot**. (5 boats)

PHRO 1 — 1) **War Pony**; 2) **Dark & Stormy**; 3) **Always Friday**, Antrim 27, John Liebenberg. (6 boats)

PHRO 2 — 1) **Split Water**, Beneteau 10R, David Britt; 2) **Sweet Okole**, Farr 36, Dean Treadway; 3) **Eclipse**, Express 37, Mark Dowdy. (11 boats)

PHRO 3 — 1) **Made Easy**, Beneteau 42, James Peterson; 2) **Ahi**, Santana 35, Andy Newell; 3) **Maggie**, C&C 37/40R, Dave Douglas. (11 boats)

SHS — 1) **Punk Dolphin**, Wylie 38, Jonathon Livingston. (7 boats, 1 finisher)

Complete results at: www.yra.org

In a sprit boat, this would almost be reasonable, but this year's Delta Ditch 'Beat' meant that the squiggles you see below are actually tacks! This was the course of Tony English's E.T.



LATTITUDE/ROB

Clockwise from top-left — the 18s take advantage of the light southerly; Trevor Bozina, Kevin Richards and Morgan Gutenkunst "three-stringing"; the winners; Brian Maloof, JV Gilmour, Dave Santori, Ellen Hoke and Matt Van Rensselaer.

Aaron Kennedy; 21) **Arc Angel**, Sonoma 30, Jack Tatum; 22) **Froggy Deux**, Merit 25, George Sirognannis. (66 starters)

Complete results at: www.stocktonsc.org

SFYC Spring Invitational

The San Francisco YC hosted its Spring Invitational for Melges 24s, J/105s, Express 37s and J/120s on the Circle also on June 4-5. Steve Madeira's *Mr. Magoo* took the J/120 title, while Kame Richards' *Golden Moon* was the top Express 37. Bruce Stone's *Arbitrage* was the top J/105, while Kristian Notto's *American Lady* took the Melges 24 honors.

SFYC SPRING INVITATIONAL (6/4-5)

EXPRESS 37 — 1) **Golden Moon**, Kame Rich-

ards, 6 points; 2) **Bullet**, Michael Maloney, 11; 3) **Expeditious**, Bartz Schneider, 12. (5 boats)

J/105 — 1) **Arbitrage**, Bruce Stone, 11; 2) **Blackhawk**, Scooter Simmons, 13; 3) **Dogot**, Phil Laby, 21. (16 boats)

J/120 — 1) **Mr. Magoo**, Steve Madeira, 10; 2) **Dayenu**, Don Payan, 12; 3) **Chance**, Barry Lewis, 13. (6 boats)

MELGES 24 — 1) **American Lady**, Kristian Notto; 2) **Abordage**, Erwan Le Gall, 12; 3) **Wilco**, Doug Wilhelm, 16. (5 boats)

Complete results at: www.stfyc.org

StFYC Woodies Inviational

On the Cityfront, also on June 4-5, the St. Francis YC hosted its Woodies Invitational for the Birds, Folkboats, IODs and Knarrs. After a two-race, ripping-flood series, Cissy Kirrane's *Robin* ruled the roost among the six Birds. The

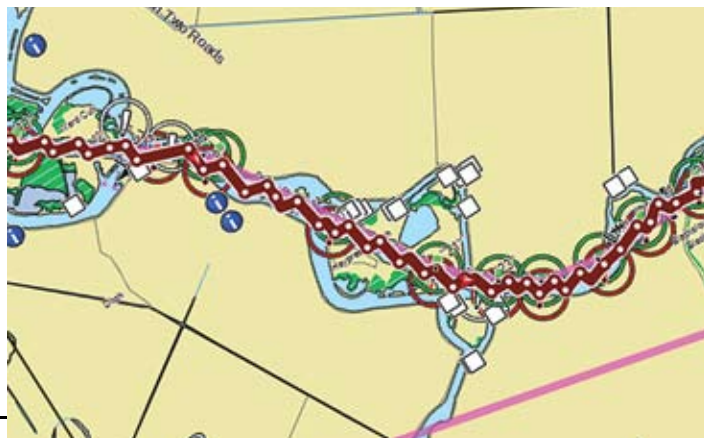

SIMON BELL

THE RACING

ONE WAY TO HALF MOON BAY (6/11)

OVERALL — 1) **Can O' Whoopass**, Cal 20, Richard vonEhrenkrook; 2) **Split Water**, Beneteau 10R, David Britt; 3) **Rhum Boogie**, Quest 33, Wayne Lamprey; 4) **Maggie**, C&C 37/40R, Dave Douglas; 5) **Whirlwind**, Wyliecat 30, Dan Benjamin. (26 boats)

PHRO 1A — 1) **Bodacious+**, 1D 48, John Clauser/Bobbi Tosse; 2) **Leglus**, Ohashi 52, Hiro Manami. (2 boats)



Ross Stein

PHRO 1 — 1)

Always Friday, Antrim 27, John Liebenberg; 2)

War Pony, Farr 36, Mark Howe; 3) **Low Speed**

Chase, Sydney 38, James Bradford. (4 boats)

PHRO 2 — 1)

Can O' Whoopass; 2)

Split Water; 3) **Rhum Boogie**. (7 boats)

PHRO 3 — 1)

Maggie; 2) **Green Buffalo**, Cal 40, Jim Quanci;

3) **Mimicat**, Hinckley 38, Robert Long. (8 boats)

SHS — 1) **Culebra**, Olson 34, Paul Nielsen; 2) **No Ka Oi**, Gibsea 42, Phil Mummah; 3) **Darwind**, Pearson Triton, Tom Watson. (5 boats)

Complete results at: www.yra.org

Sperry Top-Sider NOOD Regatta

The St. Francis YC's Sperry Top-Sider NOOD Regatta brought out 121 boats in nine one design divisions and one IRC division for five races June 25-26. With pressure in the high 20s to low 30s on Saturday, the sailors got a workout, and the results sheet saw plenty of letter scores.

Sailing on the Bay as a one design for probably the only weekend of the year, the Corsair 24s drew seven boats and BAMA's Ross Stein sailed his *Origami* to a straight-bullets win. The other multihull division, the 16-boat F-18 class, went — along with the class's West Coast Championship — to Ian Sammis' Long Beach-based **KANSAS**

The Melges 24s get mixed up at the massive Ullman Sails Long Beach Race Week. Sailing in shorts is fun every once in a while.

with a 1-2-1-1-5.

The 15-boat Laser division went to Hall Spars' rig designer and former Masters Worlds winner Scott Ferguson from Newport, Rhode Island, who ran away with the division, beating Russ Silvestri by 21 points. The 17-boat Radial division went to Leukemia Cup honorary skipper and lymphoma survivor Drake Jensen, on a tiebreaker with Domenic Bove.

The Weta trimarans drew a nicely sized fleet with 12 boats, won by dealer Dave Berntsen. Of the four one design keelboat classes, the Express 27s drew 10 boats, with Brendan Busch's hull #1 *Get Happy!!* taking the top honors. Nine J/24s also came out with Michael Whitfield's *TMC Racing* scoring only bullets and one second for the win. Bart Hackworth's *Gruntled* won the 14-boat Moore 24 class with a three-point margin. The J/105s were tops among the keelboats numbers-wise, and Bruce Stone's *Arbitrage* ran away with the win in the 17-boat fleet, finishing 11 points clear of the runner-up. In the IRC division, Wayne Koide's Sydney 36 *Encore* narrowly beat out the rest of the five boat division for the honors.

SPERRY TOP-SIDER NOOD REGATTA StFYC (6/25-26)

CORSAIR 24 — 1) **Origami**, Ross Stein, 5 points; 2) **Gaijin**, Peter Adams, 15; 3) **Blown Away**, Rick Hall, 20. (7 boats)

EXPRESS 27 — 1) **Get Happy!!**, Brendan Busch, 8, points; 2) **El Raton**, Ray Lotto, 9; 3) **Peaches**, John Rivlin, 19. (10 boats)

F-18 — 1) **KANSAS**, Ian Sammis, 10 points; 2) **Water Bison**, Alex Van Brunt, 17; 3) **Tiger**, Jason Moore, 26. (16 boats)

J/24 — 1) **TMC Racing**, Michael Whitfield, 6 points; 2) **On Belay**, Don Taylor, 14; 3) **Downtown Uproar**, Darren Cumming, 19 points. (9 boats)

J/105 — 1) **Arbitrage**, Bruce Stone, 8 points; 2) **Donkey Jack**, Rolf Kaiser, 19; 3) **Blackhawk**, Scooter Simmons, 20. (17 boats)

LASER — 1) **n/a**, Scott Ferguson, 10 points; 2) **Black Tulip**, Russ Silvestri, 31; 3) **Cabarete**, Ari Barshi, 31. (14 boats)

LASER RADIAL — 1) **Friendly Dragon**, Drake Jensen, 22; 2) **n/a**, Domenic Bove, 22; 3) **n/a**, Christine Neville, 28. (17 boats)

WETA — 1) **n/a**, Dave Berntsen, 6 points; 2) **Bobanja**, Robert Hyde, 14; 3) **Akahele!**, Bruce Fleming, 16. (12 boats)

MOORE 24 — 1) **Gruntled**, Bart Hack-



LATTITUDE/ROB

worth, 8 points; 2) **Adios**, Scott Walecka, 11; 3) **Banditos**, John Kernot, 14. (14 boats)

IRC — 1) **Encore**, Sydney 36, Wayne Koide, 8 points; 2) **TNT**, Brad Copper, 9; 3) **Mirthmaker**, A-35, Douglas Holm, 9. (19 boats)

Complete results at: www.stfyc.org

Ullman Sails Long Beach Race Week

After *Dark Star* mauled the marquee Farr 40 class in Ullman Sails Long Beach Race Week June 24-16 with three wins in seven races, including the last one that it didn't even need to sail, owner/skipper Jeff Janov was ready to talk: "It wasn't as easy as it looked."

Two days earlier Janov feared setting himself up for a fall — and, in fact, there was plenty of opportunity, from shifty light winds to bad starts and constant pressure from 10 other boats.

"The results don't show how tough the fleet is," said Janov, whose team also dominated the class's North Americans on the same waters a month earlier. "It's definitely an exercise in blood pressure management. I love it . . . most fun I've had."



RICH ROBERTS



Normally we don't cover intra-club events, but if we catch you looking this good, we might as well run your photo. 'B-line' and 'Vuja De' in the Richmond YC's Barbary Coast Race.

Dark Star's 17-point winning margin was the widest in any of the 15 classes contested by 150 boats. Three were resolved on tiebreaker countbacks: Gary Mozer's *Current Obsession* over David Gould's *Air Boss* in the J/105s, Steven Ernest's *Aimant de Fille* over Marty Burke's *Bella Vita* in the Beneteau 36.7s and John Laun's *Caper* over Chuck Nicholls' *CC Rider* in the J/120s.

Others weren't so close. Deneen Demourkas' nearest pursuer in the Farr 30s was her husband John, three points behind. Both sailed boats named *Groovederci*, she winning four races and he two of the other three, neither with a finish worse than third. But their sights for the fleet were on the Farr 30 Worlds to be run as part of the Big Boat Series in San Francisco in September.

Santa Barbara's Deneen Demourkas is president of the international class and debuted on the West Coast after

competing in Europe and the East Coast the last several years.

"I was here as a goodwill ambassador to get people up to speed," she said. "We should have at least 15 boats in San Francisco."

Tim Carter, sailing *Viral*, logged five firsts and two seconds to win the 16-boat Viper 640 class by 13 points, noting, "We had good boat speed, calling the lifts and keeping our heads outside the boat to avoid the kelp — and our Ullman Sails were great."

But the weekend didn't start well; *Viral* started prematurely in the first race on Friday but didn't realize it until "we were 300 yards up the course," Carter said. "We went back and picked off boats all around the course to finish first."

The biggest comeback win was in the Open 5.70s, the largest class, where dealer Jerome

Sammarcelli came from nine points behind in the last two races Sunday to win the 21-boat class.

PHRF Boat of the Week honors and a \$1,000 Precision Swiss Time watch went to David Team's TP 52 *Rebel Yell*, which posted a 1-1-3 score on corrected handicap time in the 10-boat Random Leg competition, followed by Ed Feo's Andrews 45, *Locomotion*, which won Sunday's race, and Bob Lane's Andrews 63, *Medicine Man*.

Mozer also collected a watch with *Current Obsession* as One Design Boat of the Week.

The Kent/Golison Family Trophy was won by Steve Wyman's J/80 crew on *Nununu*

Team Alamos Bay YC, with three first places — Catalina 37s with Chuck Clay

as skipper, Schock 35s with Michaelis and Viper 640s with Carter — won the Yacht Club Challenge. David Anderson and Neil Martin received the farthest travel award for coming from the UK to charter a Catalina 37. Complete results can be found by searching for "Ullman Sails Long Beach Race Week" in your favorite search engine.

— Rich Roberts

Sausalito YC Hobie Regatta

The Sausalito YC hosted its first annual Hobie cat regatta June 11-12. The regatta, with over 40 entrants competing in Hobie 16s, 18s and 20s, showcased multihull racing on the bay, on a Knox race course. With much of the fleet comprised of out-of-towners, organizers had to have been hoping for a more mellow day on the Bay, but the breeze had different ideas, and greeted the racers with some nuclear conditions that were scratching the high 30s!

It wasn't long before San Francisco and St. Francis YCs had dispatched extra rescue boats to help the Sausalito YC fleet deal with the carnage which in some cases spilled over into the shipping lanes and separated boats from sailors. Fortunately no one was hurt and no boats were lost completely, although many suffered breakdowns as severe as dismastings. The result of all the carnage on the first day, and that induced by the 25-knot second day, was more letter scores than numbers in the results!

Regardless, there were enough races finished to crown winners in all the fleets. In the Hobie Tiger and Wildcat division — both models are F-18s — Charles Froeb and Jim Johnstone

Bill Colombo, left, and Chris Corlett enjoy a nice lazy cruise around the Rockpile aboard 'Split Water' in the Full Crew Farallones on June 11.



THE RACING

emerged victorious after 1-1-DNF-DNS-DNS in the seven-boat division. Tim and Jane Parsons were the only team to finish every race in the Hobie 20s and took the honors in the 12-boat division. Brett and Michael Peterson squeaked past five other Hobie 18s to win that division. The Hobie 16s were divided into two divisions, with Adam Borcharding and Waseem Lufti taking A Division and Andrew Esler and Karina Cherif taking B Division.

Given that it doesn't have the facilities to launch a bunch of beach cats at the Club, Sausalito YC worked with Clipper Yacht Harbor to create a "Hobie Village" on the latter's peninsula in Sausalito that housed the entire fleet. By all accounts, the arrangement was a success, with many sailors beating the high cost of lodging in Marin County by camping out at the Hobie Village.

Etchells Worlds

The 2011 Etchells World Championship regatta was supposed to be a nine-race series, but San Diego's Bill Hardesty with crew Steve Hunt, Mandi Markee and Craig Leweck needed only eight races to take the title.

The win — Hardesty's and Hunt's second (they won their first in Chicago in '08), and Markee and Leweck's first — was far from a lock as the eighth race developed, with the team rounding the first three marks in 8th, 7th, and 7th respectively.

A right shift on the last downwind leg

A lovely evening for a Corinthian Friday Night Race; it's not often you're doing this with a spinaker up across the slot in June!



LATTITUDE/ROB

Andy Newell's Santana 35 'Ahi' just rumbling down the Bay during the Summer Sailstice Race.

allowed the team's USA 979 to pass five boats and round the last leeward gate in second place, which they were able to hang on to.

The Bay was well represented at the event, with Craig Healy winning that eighth race and finishing 10th overall, and Don Jesberg finishing fifth overall as the top Corinthian competitor, one spot ahead of ever-competitive Dennis Conner.

Peter Vessella finished in 16th place, Philippe Kahn finished in 53rd and Bill Melbostad finished in 80th due to equipment failure.

The win also marked the first time a full-time sailing journalist — Leweck edits the popular *www.sailingscuttlebutt.com* website — has ever won a legitimate world championship (ed. note: well done Craig!). Complete results are available at: www.etchellsworlds2011.com



LATTITUDE/JOHN

27th Annual

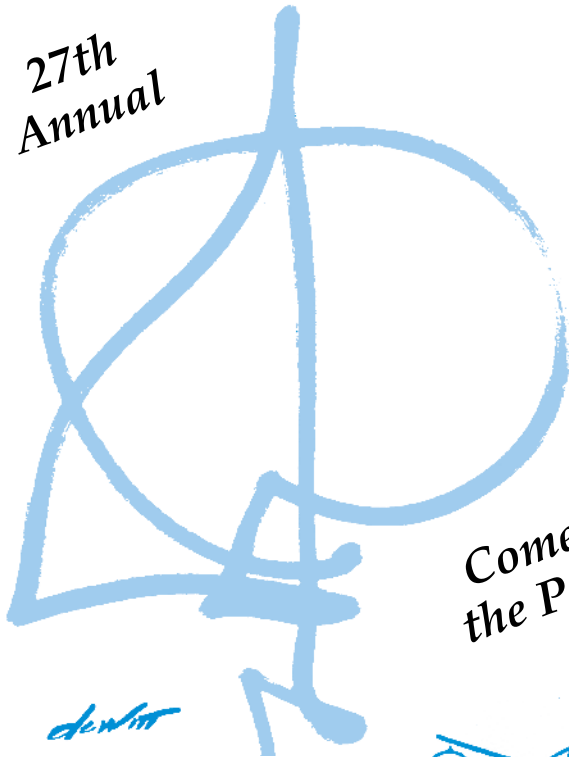

Come to the Party!



THE BAY VIEW BOAT CLUB AND THE ISLANDER BAHAMA FLEET invite all

'60s & '70s Vintage Fiberglass Sailboats

to the San Francisco

PLASTIC CLASSIC

REGATTA

and

Concours d'Elegance

Saturday, July 16

at the Bay View Boat Club and the waters of Pier 54

For more information visit our Web site: www.bvbc.org

Bay View Boat Club

489 Terry Francois Blvd., San Francisco, CA 94107

TROPHIES TO PRETTIEST BOAT AND FASTEST OVERALL

10 a.m. UNTIL DARK • RACE STARTS AT 1 p.m. • TROPHY PRESENTATION AT 7 p.m.



Set in a picturesque location in the heart of the Sacramento River Delta, the marina has 200 feet of fuel dock with gas and diesel, and Wi-Fi throughout the marina.

Enjoy our Rio Vista location, minutes from:

- ◆ Shopping
- ◆ Dining
- ◆ Entertainment



With almost 800 feet of guest docking, we have room for your friends and visitors – or for a club visit.

NEW BERTHER SPECIAL

Pay for six months rent in advance and get the seventh month **FREE**

RARE UNCOVERED SLIPS AVAILABLE!
(866) 774-2315

See us online at:
www.deltamarina.com
info@deltamarina.com



GUL

PERFORMANCE APPAREL

SUMMER 2011 TECHNICAL RANGE

- Wetsuits • Spraytops • Rashguards
- Gloves • Footwear • Surf Hoods

IN STOCK NOW AT

murrays

Toll-Free (800) 786-7245

www.murrays.com



DISTRIBUTED BY:

STRIGHT-MACKAY

stright-mackay.com

WORLD

With reports this month on **'Shoulder Season' Getaway Options**, a look inside a **Charter Junkie's Ditty Bag** and **Charter Notes**.

Late Summer Chartering: Still Plenty of Time to Plan and Go

As we write this, summer has just begun, and many travelers are undoubtedly putting the final touches on their plans for summer sailing vacations. How about you? If you're sitting there with a blank stare on your face because you don't even have the beginnings of a getaway game plan, fret not. There's still plenty of time to organize a late-summer escape — and sailing in late summer has some distinct advantages.

If you have school-age kids — or perhaps you're a school teacher yourself — you're probably forced to take only mid-summer vacations. But if not, we'd highly recommend that you travel shortly after Labor Day for a number of reasons. The first is obvious: After K-12 schools and colleges are back in session there are simply far fewer people — particularly North Americans — out traveling. That means there will be shorter lines at the airport, quicker checkouts at the charter base, fewer boats in the anchorages, fewer snorkelers in the prime dive spots, and quicker service if repairs are needed. Plus, shops, restaurants and hotels will all be less crowded, so you're likely to get better service than you would during the peak summer season when service staff are stressed out and exhausted. You might also get a better choice of boat types in the so-called shoulder season. And in some areas, as discussed below, you'll probably find much better sailing

It's easier to find a free mooring ball in the San Juans in September. Don't worry about the clouds, as they often bring a fresh breeze.

conditions.

Let's look at a few popular summer sailing venues: We absolutely love sailing in the Gulf and San Juan Islands of the Northwest, but so do thousands of other sailors. Consequently, during mid-summer the anchorages and waterside resorts tend to get quite crowded. So much so, in fact, that many sailors rush to secure a spot in early afternoon, rather than fully enjoying the extremely long days there by sailing until 8 or 9 p.m. The only other thing that's often disappointing in that lush green wonderland is the breeze — especially in the hottest months of mid-summer. As fall approaches, though, weather is typically more changeable, and that often leads to more wind. Up there, we never fret about approaching clouds, because we've had our most memorable stints of Northwest sailing under cloudy skies.

The points made above also apply, generally, to sailing in Maine and other parts of New England. The massive Chesapeake Bay estuary, for example, is often delightfully sunny and warm during mid-summer, but the breeze is typically very light or non-existent. But when the temperature begins to get cooler in September and early October, sailing conditions are generally much better. And, of course, there are fewer boats competing for space at quaint, centuries-old villages such as St. Michaels and Oxford.

Western Europe used to be a favorite getaway destination for North American travelers of all stripes, but lately they've been avoiding it like the plague due to the sky-high prices caused by the strength of the euro. In case you haven't heard, though, the relative value of the euro has been seriously sliding downward lately. And that makes the U.S. dollar stronger 'on the continent' that it has been for years — great news if you've been itching

to do some sailing in the Eurozone.

If you like to mix travel under sail with poking around ashore in culturally rich towns and harbors, it's hard to top Western Europe. And whether you choose to sail the coast of Brittany, the French Riviera, Corsica, Sardinia, Croatia, Spain's Balearic Islands, or Italy's Lipari Isles, they'll all be less crowded in late summer or early fall. Most Europeans vacation in August, eager to become bronzed by the summer sun, but by mid-September most sailing venues have a very different feel. Anchorages and stern-tie seawalls are much more manageable, while the sailing conditions are often much better.

Longtime Aegean charter skippers tell us the prime sailing grounds of the Greek Isles and the Turquoise Coast of Turkey see their most consistent sailing breezes in late May and mid-September. Here again, most European tourists — especially those from Northern Europe — seem to care a lot more about ideal conditions for body baking than sailing. As wonderful as the Greek Isles are to explore via sailboat, the most popular ones can get so crowded in mid-summer that some sailors find themselves avoid-



OF CHARTERING



TURKISH TOURISM

Spread: With its famous castle, Turkey's Bodrum Harbor is popular all summer, but less so in September. **Inset:** Blasting to Huahine in Tahiti's Leeward Islands.

ing famous places that they'd been eager to visit for years. And while the Turkish coast is never terribly crowded, it too is much more peaceful during the final weeks of summer.

You won't find huge bareboat fleets or crowded anchorages at any time of year in Tonga or the Leeward Islands of Tahiti. And because they're fed by trade winds, the Northern Hemisphere's mid-summer is as good a time as late summer to sail there. But here are a couple of arguments for considering one of these destinations this year in late-summer: At least half of Tahiti's visitors are Europeans, and as we said, they love to travel in mid-summer, particularly August, so in September you'll typically compete with fewer tourists for services ashore. Most cruisers have moved on by then also, so the anchorages will be even more tranquil — not that tranquility is ever in short supply in these dreamy isles.

Considering the size of Tonga's tiny bareboat fleet at Vava'u, and its seemingly endless assortment of idyllic,

well-protected anchorages, we can't imagine ever using the word 'crowded' to describe this mid-Pacific kingdom. In fact, our suggestion to you is to consider chartering there at its 'busiest' time of year, September 7-13, so you can take part in the fun-packed Regatta Vava'u. Combining low key racing with a full menu of shoreside activities, this event introduces both bareboaters and cruisers to the finer aspects of Tongan culture along with the warm hospitality of its ever-friendly people.

How's that for a full palette of late summer sailing options? With so many worthwhile possibilities, you really have no reason to sit around and sulk. So we suggest you fire up your computer, do some further research, and lock in a booking soon. That ought to put a smile on your face.

— latitude/andy

Always Pack Light But Don't Forget Your Ditty Bag

What's our advice on pack-

ing for a tropical charter vacation? Pack light. Very light. In fact, being longtime charter addicts ourselves, the best advice we can share with you is to pack everything you think you'll need, then dump it all out on the floor and leave half of it behind.

Seriously, the vast majority of charter bases are located in warm climates, where you'll spend most of your time in a swimsuit or shorts and a T-shirt. And in such places even the night spots are typically super-casual, so it really doesn't make sense to arrive with a suitcase or duffel bag big enough to carry a small farm animal — and possibly throw your back out in the process. Some frequent charterers have it down to a science, bringing no more gear than will fit in a carry-on bag.

Having said all that, there are a few essential items we'd suggest you bring on every charter, even if you wear the same swimsuit and tank top all week long.

In the most popular charter venues, such as the British Virgin Islands, bareboat operators have mechanics and riggers standing by who can jump into a chase boat and perform 'surgery' on your boat's systems within an hour of your call for help. Even so, there may be times when you need to tighten a few screws or improvise a simple repair that's not worth calling the fix-it squad for. In 20+ years of frequent chartering, we've never been on a bareboat yet that had a decent tool kit. Maybe it's because

Wherever you charter, bringing along a few simple tools can save you lots of time and frustration.



WORLD

they get ripped off, or perhaps the charter companies just don't want you messing with things. Who knows? But if you can honestly say you're mechanically inclined, we'd advise bringing along a few simple tools — pliers, screwdrivers, a rigging knife, or a multi-tool. We always do, and they've saved us hours of waiting around for help.

When you do long distance charters that take you far from your charter base, like, say, a one-directional trip from St. Lucia to Grenada, your need to improvise once in a while is likely to increase. We're not talking about doing major engine repairs or rebuilding an anchor windlass. But boats that get worked hard week after week are bound to have some bits and pieces shake loose once in a while, and it's nice to be able to whip out your trusty Leatherman and put things back together again.

Maybe it's just our bad luck, but on the boats we've chartered over the years the thing that's even more conspicuously absent than basic tools is 'cordage', as the old salts would say. You know, bits of line for securing gear on deck, or for



As any old salt will tell you, ya gotta have cordage! And it doesn't hurt to bring along a snatch block or two also.

tweaking your sail trim. Honestly, we haven't been on a bareboat yet that had any unused line other than docklines. So we bring a small variety. We use light stuff for lashing down kayaks, windsurfers or whatever other toys our entourage might have brought along.

A small amount of super-strong Spectra line can really come in handy when you need to make an emergency

repair because it is as strong as or stronger than wire. Once our buddy boat's mainsheet car ripped right off the traveler track when we were still a half day's sail from our destination. Thanks to the little coil of Spectra we'd brought along, we had it jury-rigged in less than 10 minutes, and the lashing lasted for the rest of the charter.

Although heavier line is bulky, we always bring a coil about 25 feet long — especially on catamaran charters — as well as a snatch block. We use them to rig a preventer on the main, to barber-haul the jib sheet lead for better sail shape, or, when going downwind on a cat, to wing out the clew of the headsail so it stays flat and full while bouncing over the swells. This little trick is especially useful with self-tending jibs on a foredeck track, which tend to lash around on every swell, making a god-awful racket belowdecks.

Another trick that can save you a lot of huffing and puffing, is rigging the snatch block so your main halyard leads to the capstan of your anchor windlass — thus letting the windlass do the work. If you've

Tortola BVI
Belize
The Grenadines

**UNIQUELY
TMM**

Marisa
TMM Belize

Most charter companies offer blue water & palm trees, but it takes the personalized care of people like Marisa to make your vacation a success.

Like Marisa, everyone at TMM is committed to your complete satisfaction. Our specialized three-location operation offers large company quality with small company service. A combination that is uniquely TMM.

TMM
Yacht Charters
Since 1979

catamarans • monohulls
motor yachts
ownership programs

 **www.AVINAUTICA.COM**

*The charter companies
you know and trust - for less !*

**Tahiti Flotilla
November
Join us!**

The Moorings **Footloose**
SAILING CHARTERS

Sunsail **le boat**

50 Destinations - 30 Countries

For great, personal service:
davidkory@gmail.com (925) 787-6893
Authorized Preferred Broker

OF CHARTERING

ever tried to raise a fully battened, big roach main by yourself in the tropical sun, you'll understand why we think this is a pretty slick trick.

The other group of extras we always bring along come from the drug store. When traveling to far-flung places you never know when you're going to feel a little funky, either from the pent-up stress that comes from rushing to get out of town, unfamiliar food, or whatever. And you never know when one of your charter guests is going to feel just a wee bit queasy, although not officially seasick. So we always bring along some good old Pepto-Bismol tablets, and some Imodium in case of more dire indigestion.

Most folks are smart about bringing an ample supply of sunblock these days, but not everyone thinks to bring an anti-itch lotion. Sailors who aren't used to being in the tropics — i.e. covering up before 'bug hour' — can become so rattled by mosquito or no-see-um bites that they can't think about anything else. And scratching them, of course, only leads to greater agony when the tiny bites

get infected. But after applying an over-the-counter antihistamine, such as Benadryl, most of the itching subsides, allowing the human pin cushions within your crew to rejoin the party.

Because we cherish a good night's sleep, we never travel without ear plugs, and we'd suggest you follow our lead. Not just so you can avoid the infernal blabbering of the two over-caffeinated salesmen sitting behind you on the plane, but so you sleep through the creaks and groans of an unfamiliar boat — and the cacophony of snoring performed by your shipmates every night. Yeah, we know, what about during rough weather? Whenever possible, we dive on our anchor to be sure it's well set, then we don't hesitate later to plug in and tune out. (But every skipper has to make his own set of safety rules.)

What else? A headlamp always seems to come in handy, not only for doing repairs in dark places, but for reading in



It's always smart to be prepared for boat bites, bug bites, upset tummies and sunburn. And whatever you do, don't forget the ear plugs.

poorly lit parts of your cabin. An extra handheld VHF often comes in handy, as does a handheld GPS, but at some point you have to put on the brakes and say, "Enough already," zip up your duffel and call it good. These are some of the essential items in our ditty bag. What travel accessories do you consider to be essential when chartering? (Write andy@latitude38.com)

— *latitude/andy*

Real People. Real Sailing. Real Fun.



Sail Cats | Power Cats
Monohulls | Trawlers
Bareboat | Skippered

Real Choices.

Choose CYOA and become part of the family. We've been providing beautifully maintained yachts, personal service and sensible prices to sailors since 1980.

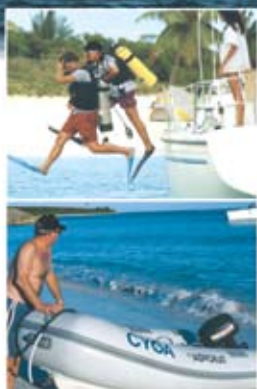

1-800-944-2962
info@cyoacharters.com
www.cyoacharters.com
St. Thomas USVI 00802

CYOA
YACHT CHARTERS

COME PLAY HOOKEY WITH US!

We sail 3 times a day, 7 days a week, and it is so much easier than having to clean all the bird crap off your boat, put up the sails, etc. We make sailing hookey easy...



\$10 discount off full fare on our Bay Cruises at 1pm and 3pm if you make your reservation at (800) 498-4228 and mention **Latitude 38**. Monday-Friday only. (Nobody plays hookey on weekends!)

WORLD OF CHARTERING

Charter Notes

One of the best ways we know to be successful in business is to fill a unique niche with no competition — that is, create a monopoly within a particular market. That doesn't happen often in the world of yacht chartering because many savvy skippers typically flock to the most desirable sailing destinations.

But we think we've discovered a remote chartering enterprise that has its niche completely sewn up. Where? On **Lake Titicaca**, which, as geography buffs and adventure travelers know, straddles the **Peru-Bolivia** border and, at 12,500 feet above sea level, is the **highest navigable waterway** on earth.

A company called **InkaSailing Charters** has built a modernistic lodge called Titilaka at the edge of this primeval body of water, and offers daysails on the



Want to do something truly special on your next vacation? How about daysailing on two-mile-high Lake Titicaca?

50-mile long lake aboard a **Hunter 31** named **Thaya**. We're not making this up — honest.

The last time we heard about a sailboat on Lake Titicaca was in a Tristan Jones book, and some people think he made the whole thing up. But this operation is for real, and its operators not

only **speak English**, but they've been certified by their national maritime authority.

Believe it or not, we've been to Lake Titicaca, but back then the closest things to sailboats that we saw were Thor Heyerdahl-style reed rafts that the local *indigenes* paddled from one village of reed huts to another. If someone had sailed up in a Hunter 31, we probably would have assumed we were hallucinating from the altitude, and needed another cup of coca tea to acclimate.

We must say, the more we look into this operation, the more we think that few places on the planet would be more unique to sail than this rugged, sparsely developed Andean lake that's literally perched on top of the world. See www.inkasailing.com for more info. And if you go check it out, be sure to report back to us.

SAN JUAN ISLANDS



Bareboat Charter Sailing

Fly to Bellingham, WA and set sail to explore the beautiful San Juan Islands! Charter bareboat or with a skipper. Our fleet of 33 sailboats and a growing fleet of trawlers offer you the newest vessels available for charter. All are maintained to the highest standards of preventive maintenance in the charter industry worldwide! (Airfare SFO/OAK to BLI approx. \$250)

Ask for our "\$100 Off" Latitude 38 Special!

CHARTER
40 Exceptional Yachts
from 30 - 49 feet



SCHOOL
AMERICAN SAILING ASSOCIATION

28 Years of Sailing Excellence

We certify more Bareboat Skippers than any other school in the Northwest!

1-800-677-7245 • sanjuansailing.com



BVI YACHT CHARTERS

Call: +1 888 615 4006
Or: +1 284 494 4289

BVI Yacht Charters is the first port of call for all yacht charters in the BVI and St Martin. Whether you are looking for a Catamaran or a Monohull, a week or just a few days, our professional team is on hand to make it work, your way.

BVI YACHT CHARTERS

** 10% off all new bookings when you mention this ad.

www.bviyc.com
charters@bviyc.com

BAJA HA-HA XVIII

BROUGHT TO YOU BY
THESE OFFICIAL SPONSORS



WWW.BAJA-HAHA.COM

The Rally Committee encourages you to patronize the advertisers who make this event possible – and take advantage of their Baja Ha-Ha Specials!
(Turn the page for more.)

Summer
is safe at
Paradise



Enjoy
your stay
with us!

011-52 (322) 226-6728 • www.paradisevillage.com
marina@paradisevillagegroup.com

Your
Yacht Club
South of the
Border



Home
of the
Banderas Bay
Regatta

Vallarta Yacht Club

<http://vallartayachtclub.org>
<http://banderasbayregatta.com>

Everything you need from a full service yacht club.

ARE YOU READY TO HA-HA?

As we go to press, this year's Baja Ha-Ha fleet is shaping up to be as diverse as ever. Nearly 100 boats are signed up already, ranging in size from 28 to 85 feet. As always, the backgrounds of their owners are as diverse as the boats they sail on.

The smallest so far is John Neely and Shannon Walker's Berkeley-based Caliber 28, and the largest is Mike and Dawn Hilliard's 85-ft schooner *Destiny*, from Friday Harbor, WA. You'll find the complete list at www.baja-haha.com.

If you're new to the event, let us explain that the Ha-Ha is a 750-mile cruisers' rally from San Diego to Cabo San Lucas, with stops along the way at Turtle Bay and Bahia Santa Maria.

You'll find frequent updates on this year's event on 'Lectronic Latitude' at www.latitude38.com. And look for a complete recap of the event in the December issue.

SELF-STEERING AND EMERGENCY RUDDERS



Factory
Direct

432 South 1st Street • Pt. Richmond, CA 94804
Toll Free: (888) 946-3826 • Tel: (510) 215-2010
email: scanmar@selfsteer.com • www.selfsteer.com

Nautical Books, Software, Charts and more!



WAYPOINT

621 - 4th St., Oakland, CA

www.waypoints.com • (510) 769-1547

RIGGING ONLY

Standing and running rigging, lifelines, furlers, winches, headsail poles, main slider systems, windlasses, travelers, wire terminals, blocks and more...
Expert advice for selection and installation.

Since
1984

www.riggingonly.com

(508) 992-0434 • sail@riggingonly.com



Award-winning Marine Communications Equipment

Handhelds • Mounted VHF • SSB • AIS

Visit one of our many West Coast dealers

www.icomamerica.com/marine

MARINA DE LA PAZ FULL SERVICE MARINA



Conveniently located downtown

Tel: 011-52 (612) 122-1646

Fax: 011-52 (612) 125-5900

email: marinalapaz@prodigy.net.mx

www.marinadelapaz.com

West Marine®

Call

1-800-BOATING

(1-800-262-8464)

for a catalog or the store nearest you.



Est. 1973

Almar Marinas

Everywhere you'd like to be
almar.com

BAJA HA-HA XVIII



Yachtfinders/Windseakers
in the heart of
San Diego's boating community
Specialists in cruising sailboat brokerage for 29 years
info@yachtfinders.biz • www.yachtfinders.biz
(619) 224-2349 • (866) 341-6189 toll-free
Fax (619) 224-4692

Let Marina El Cid
Welcome You to Mexico
A Cruiser's Paradise!
www.elcid.com
marinaelcidmzatlan@elcid.com.mx
011-52 (669) 916-3468

0036887
Serving Boaters
Since 1959

CRUISE WITH CONFIDENCE
See Our Half-Page Ad In This Issue
(800) 992-4443
www.marinersins.com
Newport Beach, CA • San Diego, CA
Burlingame, CA • Seattle, WA
Bradenton, FL • Puerto Vallarta, MX

Best Marina in Banderas Bay

MARINA RIVIERA NAYARIT
BY LA CRUISE
www.marinarivieranayarit.com
011-52 (322) 135-0798

PANTAENIUS
American Yacht Insurance
500 Mamaroneck Avenue Suite 318, Harrison, NY 10528
(914) 381-2066
Newport Shipyard: One Washington Street, Newport, RI 02840
(401) 619-1499
www.pantaenius.com
Germany • Great Britain
Monaco • Denmark
Austria • Spain • Croatia
Sweden • USA

MEET THE FLEET

Among the important dates to note (on next page) is *Latitude's* annual Mexico-Only Crew List Party & Baja Ha-Ha Reunion on September 7. There, hundreds of potential crew mix and mingle with Ha-Ha boat owners looking for extra watchstanders. To get a head start on the process, see our constantly updated free online Crew List at www.latitude38.com. As many Ha-Ha vets will confirm, the best way to prepare for doing the event on your own boat is to crew for someone else first.

IS THE PACIFIC PUDDLE JUMP IN YOUR FUTURE?

For many cruisers, the next logical step after cruising Mexican waters for a season or more is to hang a right and head west into the Pacific.

We call that annual springtime migration the **Pacific Puddle Jump**, and report on it heavily in the pages of *Latitude 38*. Making that 3,000-mile passage is one of the most thrilling accomplishments in the realm of sailing. Learn more online at www.pacificpuddlejumps.com.

VENTURA HARBOR BOATYARD

Full & Self Service Facility
(805) 654-1433
Two Travelifts • Haul Outs to 160 tons
www.vhby.com
Shoreside Work Slips • Emergency Repairs

Not just a marina – a cruiser's community
Your best destination across the Sea...
www.marina-mazatlan.com
011-52 (669) 669-2936 & 2937
elizarraga@marinamazatlan.com



Survive Your Dream
ECHO Tec Watermakers
604-925-2660 **www.hydrovane.com**



www.downwindmarine.com
2804 Cañon St., San Diego
(619) 224-2733 • (800) 269-0241



www.sandiegomarine.com
2636 Shelter Island Dr., San Diego
(619) 223-7159 • (800) 336-7369
Mexico 001-500-336-7369



www.sailingsupply.com
2822 Cañon Street, San Diego
(619) 225-9411 • (800) 532-3831

INTERNATIONAL HEALTH AND EVACUATION INSURANCE

HTH Worldwide
Best in cruisers medical insurance
for the Baja Ha-Ha and beyond
WWW.HEALTHISINTERNATIONAL.COM

BROUGHT TO YOU BY THESE OFFICIAL SPONSORS



- Ultra Anchors • Ultra Swivels
- Quickline Flat Rope & Reel • Ultra Trip Hooks
- Ultra Chain Grabs, Ultra Snubbers & Ultra Bridles



www.Quickline.us
www.UltraAnchors.us
sales@Quickline.us
714-843-6964

The World's Highest Quality Marine Products



La Paz Hotel Association

November 17: La Paz Baja Ha-Ha Beach Fiesta on the Malecón at the Papas and Beer restaurant.

011-52 (612) 122-4624
or (612) 125-6844

www.visitlapaz.org



A Full Service Boat Yard in Puerto Vallarta
88 ton Travelift • Parts • Service • Repairs

011-52 (322) 221-1800 www.opequimar.com
info@opequimar.com



Weather, Email and
Voice Solutions.

Satellite Phone Sales
and Rentals.

www.ocens.com

sales@ocens.com • (800) 746-1462

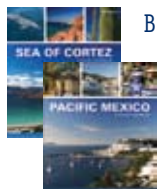

BLUE LATITUDE PRESS

The best cruising guides
for Pacific Mexico and
the Sea of Cortez

WWW.BLUELATITUDEPRESS.COM

IMPORTANT DATES

Sept. 7 — Mexico-Only Crew List Party & Baja Ha-Ha Reunion, Encinal YC in Alameda; 6-9 pm.

Sept. 10 — Final deadline for all entries.

Oct. 15 — Ha-Ha Welcome to San Diego Party, Downwind Marine, 12-4 pm. Ha-Ha entrants only.

Oct. 22 — Pacific Puddle Jump seminar, West Marine, San Diego, 5 pm.

Oct. 23, 9 am — Final deadline for all crew and skipper waivers, West Marine, San Diego.

Oct. 23, 11 am — Skipper's meeting, West Marine, San Diego. Skippers only please.

Oct. 23, 1 pm — Ha-Ha Halloween Costume Party and Barbecue, West Marine, San Diego.

Oct. 24, 11 am — S.D. Harbor Parade & Start of Leg 1

Oct. 29, 8 am — Start of Leg 2

Nov. 2, 7 am — Start of Leg 3

Nov. 4 — Cabo Beach Party

Nov. 5 — Awards presentations hosted by the Cabo Marina.

Baja Ha-Ha, LLC

c/o 15 Locust Ave., Mill Valley, CA 94941

WWW.BAJA-HAHA.COM

PLEASE NOTE: Correspondence relating to the event can be emailed to andy@baja-haha.com. Please don't call *Latitude 38* with questions. The Ha-Ha is a separate operation.



Located at
Grand Marina

www.bluepelicanmarine.com

(510) 769-4858

A Sailor's
Consignment
Chandlery

Dealer for Lavac Marine Toilets



Maritime Institute

FREE Mini-Seminars for Baja-HaHa Sailors

- Celestial Navigation • GPS • SARTS
- AIS • Encountering Major Ships at Sea

www.MaritimeInstitute.com

THE BOAT YARD AT GRAND MARINA

"Where Service Has Meaning"

Located
in Alameda

(510) 521-6100

www.boatyardgm.com



MARINE GROUP
BOAT WORKS.COM



HAUL-OUTS | BOAT REPAIR & PAINT | DRY STORAGE | MARINE STORE | PROP SHOP

SAN DIEGO BAY

1 (619) 427-6767

todd@marinegroupbw.com

SAN JOSE DEL CABO

01 52 1 (624) 105-6500

michelle@marinegroupcabo.com



CHARLIE'S CHARTS

Telling Cruisers Where to Go Since 1982!

Alaska / Canada • U.S. Pacific Coast
Mexico including Baja • Costa Rica • Polynesia • Hawaii

Helping cruisers get into the best coves and marinas, and directing them to shoreside facilities and local color found off the beaten path for nearly 30 years. Take us along on *your* adventure.

www.charliescharts.com • info@charliescharts.com

CHANGES

With reports this month on **Esprit** doing the Red Sea as deck cargo; from **Eros** on how Foxy Callwood met his wife on a TransAtlantic crossing; from **Auspice** on Mexico and the Marshall Islands; from **Azure II** on transiting the Corinth Canal; from **Leap of Faith** on four years in the Caribbean; from **Cat 'n About** on cruising on a 30-ft cat; and **Cruise Notes**.

Esprit — Peterson 46 The McWilliam Family Male to Marmaris (Boulder City, Nevada)

We just realized that we've visited a total of 12 countries, eight of them by our boat, the rest via planes, trains, and automobiles, in the last year. We've now also been on six of the world's seven continents. The only one we haven't been to is Antarctica, and we won't be visiting it

on *Esprit*. The big change in our plans occurred in February, after Scott and Jean Adam of the Marina del Rey-based Davidson 50 *Quest*, and their Seattle crew Phyllis MaCay and Bob Riggle, were murdered by Somali pirates in the Arabian Sea. So instead of taking our boat up the Red Sea on her bottom, we returned to India, then continued on to the Maldives where we put *Esprit* on a ship to Turkey.

While there were light winds in Male in the Maldives, we stripped our boat of as much windage as possible in preparation for her deck cargo passage up the windy Red Sea. It was expected that there would be at least 45 knots of apparent wind, green water over the bow of the ship, and sand storms.

One of our many frustrations involved trying to make travel arrangements without a specific load date for *Esprit*.

The Maldivé Islands are a strange place. Male, seen here, is packed to the gills, while the outer islands are mostly high-end resorts.

ESPRIT



Katie and the Capt of the 'BBC Everest' after 'Esprit was loaded.

on *Esprit*.

Fortunately, Emirates Airlines was accommodating. *Esprit* was supposed to load onto the *BBC Everest* around the 15th of March, and the loading of all the vessels was to take only two days. Well, the ship was three weeks late and it took five days to load all the boats.

On the way back to our hotel after the loading, the driver almost missed a turn in the dark, but overcompensated and drove his speedboat onto a reef! Typical of the boat operators in the Maldives. Fortunately, some divers from the ship jumped into the water to help get us off.

But if it wasn't one thing, it was another — and the next were Immigration and our travel agent. We got charged \$286 for a visa problem that friends in the same situation didn't have to pay anything for. Then our agent wanted to charge us \$750 to make changes that we didn't have to make to our flights.

Needless to say, we were happy to arrive in Dubai for a 14-hour layover on our way to Egypt and Turkey. While in Dubai, we rode the world's fastest elevator to the 124th floor of the world's tallest building, visited the world's largest shopping mall, got stuck in the sand during a 4-wheel-drive trip, and stayed in a by-the-hour hotel in the airport.

We found that Cairo, a city of 18 million, has a climate similar to that of Las Vegas — but doesn't have nearly as much vegetation. And that much of the city looks as though it's just been bombed. But we were lucky to have Sharif, an energetic 23-year-old Egyptologist, as our guide. He knew his stuff and really enjoyed his job. It would take a long time to report on all we saw.

Unfortunately, the people of Egypt — like the people in many of the countries

we visited in the past year — have not learned how to manage their trash. The result is that much of the populated areas are strewn with trash.

After arriving in Is-



tanbul, Turkey, we learned that the ship carrying *Esprit* had arrived earlier than expected. So we didn't get to spend much time in that great city. In fact, we had to take a 12-hour overnight bus ride to Marmaris, where we picked up *Esprit*. Turkey is a beautiful country!

Our boat was the last to be unloaded in Marmaris, and it was done during a big lightning storm. *SlapDash*, the boat unloaded before ours, was hit by lightning right after she got her hook down, and lost all her instruments.

By the time we got our boat docked in Netsel Marina and got back to our hotel room, we were drenched! Netsel Marina is nestled in a bay completely surrounded by high green hills, except for a small passage into the Aegean. It's a very pretty setting. We decided to leave *Esprit* there instead of moving her to Finike Marina, 140 miles to the east. The city of Marmaris is a quaint European style city, but with lots of tourist and marine stores. There's even a West Marine!

MALDIVES TOURISM



IN LATITUDES

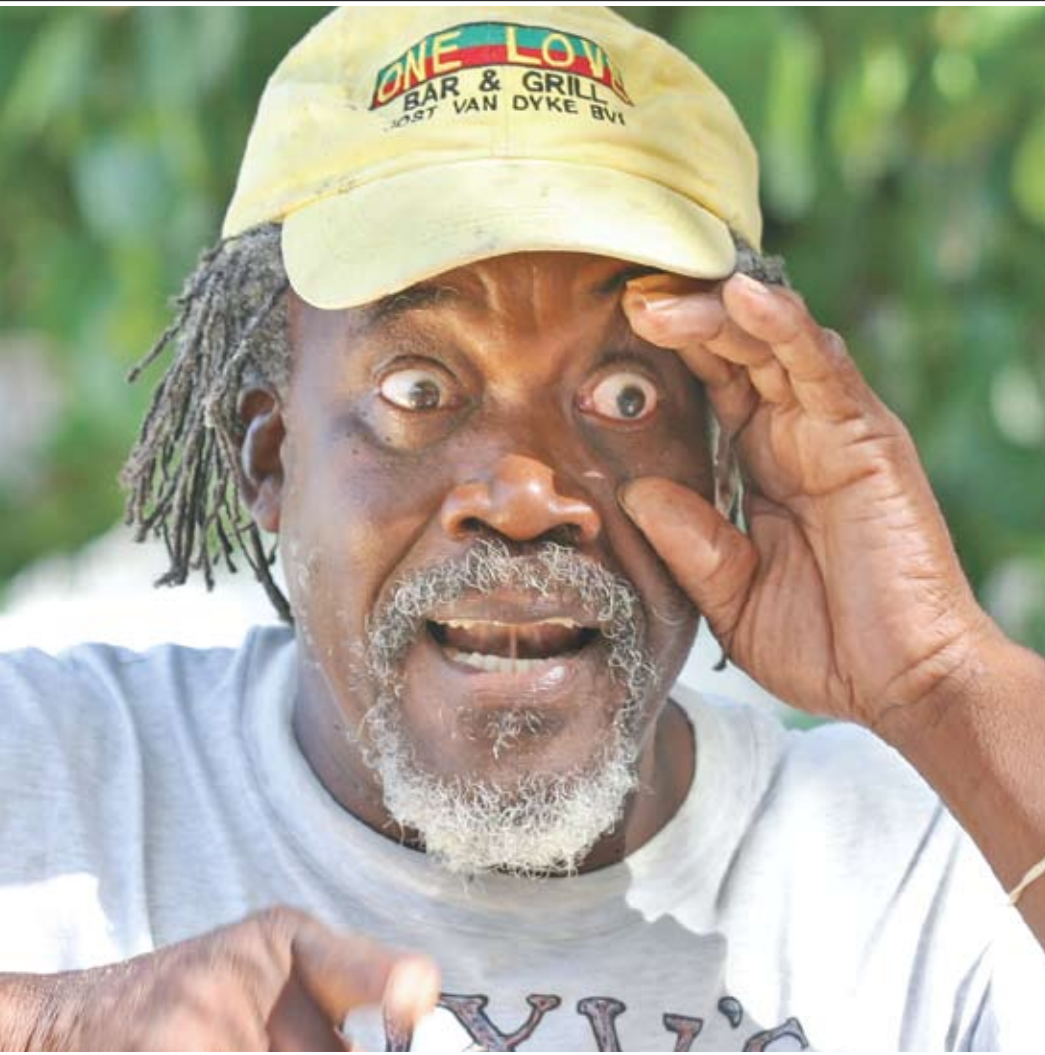

LATITUDE ARCHIVES

Insets left; One of the more typical Maldivian islands, and Netsel Marina in Turkey. Spread; The irrepressible Foxy Callwood.

We subsequently flew to London, then non-stop from London to Vegas. Since there was no food in our house in Boulder City, on our first morning back we went to breakfast at the local Coffee Cup Café, where we ordered either ham or sausage with eggs, hash browns and toast. What a treat after spending most of the previous year in countries without pork! We are now getting back into the groove of school and work, and will return to *Esprit* later for more adventures.

— katie 06/06/11

Eros — McMeek 103-ft Schooner Bill and Grace Bodle Tales of the Old Caribbean (Point Richmond)

A few months ago, we ran a *Changes* about Bill and Grace Bodle of Pt. Richmond, sailing their 70-year-old, 103-ft McMeek-designed schooner around the

Caribbean with just 21-year-old Patrick Delaney, as crew. Which is amazing, because Bill admits to being 77 and Grace happily says she's 70. In that *Changes* we promised that one day we'd let Bill tell you how they played a big part in Foxy — the notoriously fun and famous character behind Foxy's world famous bar and restaurant on Jost van Dyke in the British Virgins — meeting his wife Tessa. Well, that day has come. Here is how Bill tells the story, one that is so freewheelingly typical of the Caribbean back in the day.

"One day in the early '70s, Foxy started telling everyone he was going to sail to Europe with us aboard *Nordlys*, the 72-ft schooner we owned back then. At that point he hadn't even asked us if he could come along. It was fine with us, but we thought he was kidding, as we didn't think he'd close down his bar for the summer.

"We told him we'd come by late one night and give

him a few minutes to either get on the schooner or not. So we pulled into the little bay by Foxy's about midnight, and hollered into the darkness, 'If you're coming Foxy, get your butt out here right now!' We waited and waited, and just before the time limit expired, we were shocked to see Foxy being rowed out to our schooner by Mr. George, the vegetable man.



THE FOXY ARCHIVES

Nobody thought Foxy would close his wild bar for the summer.

"All Foxy had was a guitar, a short pair of pants, a sequined calypso shirt that some girl had made for him, and a sweater. His mother had boiled the sweater the night before to clean it, so it was about five sizes too small. Foxy doesn't have any shoes now, so he obviously didn't back then. And he was way too big for any foul weather gear we had aboard.

"The next land we saw was Pico in the Azores, and there was snow on the peaks. So you can imagine that Foxy had been freezing. In fact, when he was steering, he wrapped his feet in what had been his sweater to keep them warm.

"When we got to Gibraltar, which was a town with just one street of stores, there was a Moroccan shoe store with a huge pair of white shoes on display to attract attention. Foxy saw the huge shoes and shouted, 'Oh yeah, man, those are just what I need!' And he wore those crazy shoes the whole summer.

"Foxy was a huge hit in Yugoslavia and the smaller islands in Greece, because while the locals might have seen black men on television, most had never seen one in person. So they'd come up the gangway asking for him, and I'd call

The schooner 'Nordlys', where Foxy met Tessa while sailing across the Atlantic. 'Nordlys' was the first of the Bodles' three big schooners.



THE BODLE ARCHIVES

CHANGES

down to him down in the salon. 'Oh great!' Foxy would say, as he loved the attention. He'd grab his guitar and go down to the dock and entertain everyone. When mothers brought their kids to see him, Foxy would grab the kids' arms and pretend

BILLY 'WHITE SHOTES'



When Foxy saw the big white shoes, he saw a perfect fit.

he was a wild animal who was going to bite them with his big white teeth. They'd all shriek. At night, Foxy would lead entire small towns in parades, singing the calypso songs he'd taught them. They would have thrown him in jail if they'd had any idea how nasty the lyrics were.

"At the end of every summer, we'd stop at Terragona, Spain, for a month-long haulout. While there, Foxy asked if it was all right if he went to Munich. I don't think he even knew where Munich was, but he said he knew a woman up there. He did — and it turned out to be one of our charter guests. When he hadn't returned from Munich in a month, I had no choice but to fly to there to try to find him. There was, of course, no email or cell phones back then.

"When I got out of the plane, I told the taxi driver to take me to the Munich nightclub district. The driver thought I was looking for a hooker, because it was the middle of the day. 'Oh,' he said, 'you want to go to the Drugstore,' which was a nightclub. It was the very first place I stopped in the city of two million, and I asked the bartender if he'd seen a big West Indian guy. 'Oh, that would be Foxy,' the bartender replied. 'He was here this morning, but you missed him, as he just took a train to the mountain resort

Bill couldn't find Foxy in Munich because earlier that morning he'd taken a train to Garmisch, a most un-Jost van Dyke-like place.

BAVARIAN TOURISM



of Garmisch.'

"While in Munich, I met a friend from San Francisco, and we decided to take a side trip to London, where I could get some parts for the schooner's Caterpillar diesel. While in London, we went to a restaurant not far from Chelsea called the Tiddy Dolls. While there, we were tended to by the wine stewardess, who happened to be a very cute young blonde decked out in hot pants, boots and what have you. 'My name is Tess, boys,' she said. 'I'm wearing a sommelier's cup around my neck, but I don't know anything about wine. But if you tell me what you want, I'll bring it.'

"She ended up sitting with us and bullshitting, so we asked her when she got off work. 'When do you want me to get off?' she replied. 'Right now,' we said, 'and we can go to the 007 Club at the Hilton Hotel.' 'Blimey,' she said, 'I'd like to do that. Let's go right now.'

"While at the 007 Club, I apparently told her that she was welcome to sail across the Atlantic with us; all she had to do was meet us in Gibraltar in two weeks. I'd forgotten all about the invitation, of course, by the next morning.

"Well, Tessa hadn't forgotten about it, so when we showed up, with Foxy, in Gibraltar a little bit more than two weeks later, Tessa was there. When Foxy saw this beautiful blonde, his eyes almost bugged out of his head."

At this point Grace picks up the story.

"I'd flown home to Berkeley, where one day I opened the mail box to find a letter written in a very feminine hand addressed to 'Captain Bill'. 'What's been going on while on the schooner while I've been gone?' I wondered. So I steamed the letter open and read the letter. It went like, 'Dear Bill, where the heck are you. I've been waiting in this pisshole of Gibraltar for a week, and you haven't arrived yet. You said I could sail across the Atlantic with you. Where are you?'"

"So when Bill called to say they were leaving from Gibraltar that night, and that I could expect him in St. Thomas in about three weeks, I said that was great. Very casually, I also asked who was on the boat. Bill mentioned Foxy, Ian and all the other guys. He made no mention of any girls."

"It was on a 'need to know' basis," laughs Bill.

"What he didn't tell me is that there were three women with them. Ronda, Ian's girlfriend, a gal named Jo, and Tessa. I didn't



say a thing about suspecting there were women aboard, but I made sure I flew to St. Thomas before *Nordlys* arrived.

"In fact, the night I arrived, I was having dinner with Manfred, the well-known sailmaker, at the Hotel 1829, which has a great terrace overlooking the harbor. At about 7:30 p.m., I saw *Nordlys* sail in. 'Excuse me,' I told Manfred, 'I have to get down to the dock to see who gets off the schooner before they all escape.'

"Well, I got down to the dock before they tied up, and there was no Foxy — and Tessa wasn't there either."

"It was one of our best crossings ever," Bill jumps back in, "and people had gotten very friendly. In fact, Foxy and Tessa had fallen in love."

So why weren't Foxy and Tessa on the schooner when she arrived in St. Thomas?

"While we were sailing across the Atlantic," Bill remembers, "Foxy made some kind of deal with me, one that re-

IN LATITUDES



ALL PHOTOS COURTESY AUSPICE



If clear water is your thing, the Marshalls could be your place.

Spread: The flat waters of the lagoons make the Marshall Islands a great place for proas. Although crudely built, this one sailed fine. **Inset left:** "This isn't going to hurt a bit," Jim lied to an island patient. **Inset above:** A couple of island boys stand by a honking Yanmar diesel from World War II.

quired we stop at St. Barth first, so he could buy the dirt cheap booze for his bar in the British Virgins. I was up for the deal, but I said, 'Foxy, what about Albert, the Customs guy on Jost?' Foxy replied, 'We'll just land the booze on the beach. And,' he laughed, 'if Albert says anything, I'll kill him.'

"So we stopped at the free port of St. Barth, where Foxy bought endless cases of booze at ridiculously low prices. Then we sailed to the British Virgins, where we dropped all the booze, along with Foxy and Tessa, on the beach at the British Virgins. Finally, we sailed into Charlotte Amalie, St. Thomas."

It's been more than 40 years, and Foxy and Tessa are still together. But that's how things rolled back then.

— latitude/rs

Auspice — Schumacher 40 Jim Coggan Mexico and the South Pacific (Tiburon)

In late October of '07 — actually, the same day the Ha-Ha fleet departed San Diego — my wife Kim and sons Chris and Brian left San Francisco for Mexico. We sailed non-stop to Isla Guadalupe, which is a barren, uninhabited, Catalina-sized island 250 miles south of San Diego and 200 miles off the coast of Baja. We then rounded the corner at Cabo and sailed up into the Sea for Thanksgiving. Brian, Kim and I flew back to San Francisco, leaving Chris onboard in Puerto Escondido.

Kim and I then did a season of a month on, a month

off, 'commuter cruising' in Mexico. We had a wonderful time. But the problem became meeting the flight schedule back to San Francisco, and having to work our butts off just to meet payroll expenses. So in July of '08, I sailed over to San Carlos and left *Auspice* in Marina Seca, and returned to the mill. Don't get me wrong, I liked my work, and I'd known many of my patients for decades. But in February '09, I was fortunate to find an outstanding periodontist who wanted to take over my practice.

A month later, I loaded up our '82 Volvo with two solar panels, a DuoGen, chain, and all kinds of other stuff, and drove to San Carlos with Brian and Gordie Nash, dragging our Volvo's ass the whole way. Fortunately, Mexican Customs didn't blink an eye as we breezed across the border. Brian and Gordie drove back to San Francisco a week later, while *Auspice* went back into the water with a freshly painted bottom. Alas, she ran aground at the fuel dock that evening.

We, meaning *Auspice* and I, were on our way to the South Pacific, a lifelong dream of mine. Kim, a good sailor in her own right, but not a sailor at heart, finally decided that she'd better not let her old man sail over the horizon by himself. She didn't think that I could make it!

So she flew to Loreto with duffels fully packed, and arrived just as I was passing by. We wound up staying for Loreto Fest, stopped in La Paz for provisions, cleaned the bottom at Cabo, and off we went. It blew a gale off Cabo Falso, so we

Jim and Kim were all smiles about their relations with the people of the Marshall Islands. But they worry about the Marshallese youth.



AUSPICE

CHANGES

damaged the Edson binnacle during an accidental jibe at the very beginning of our crossing. It wasn't the most auspicious way to start a long voyage, but we arrived at Fatu Hiva less than 18 days later.

Kim might not look back on that passage as a high point in her life, but I'll tell you she's a real trooper and one courageous woman. I think I would have made it solo, but it would have been a much harder trip. But it was sharing that crossing with Kim, and all the special moments we had, that meant the most to me.

Auspice is an incredible boat. She's first and foremost a racing boat, but it turns out she's also an excellent cruiser for a couple. Every day I think about designer Carl Schumacher with admiration and respect, and I continue to feel privileged to have one of his boats. We've owned *Auspice* for 10 years now, and I want to thank Warwick 'Commodore' Tompkins for pointing us in her direction.

So far, we've done the usual Coconut Milk Run, with Kim doing all the passages. We spent the cyclone season in New Zealand in order to disassemble the rig, inspect the hardware, and re-head all the rod rigging. We didn't find any defects in the rigging, but we now have even greater confidence in the rig.

This season we sailed north of the equator to explore the Marshall Islands, where we met wonderful, happy people

A beautiful South Pacific sunset was spoiled by the presence of mostly Asian factory ships, depleting the fishery.



AUSPICE

Cruising the South Pacific suits Jim just fine.

living in very humble circumstances. The diving and snorkeling was the best, with 100-ft visibility the norm, and it sometimes being twice as much. The fishing was adequate as a source of food, but we sensed fishery depletion everywhere we went.

The islanders fish for subsistence and are not the problem. Indeed, it's sad to see them using nets along the beach to catch minnows, careful not to let a single one get away. No, the problems are the purse seiners and long liners, mostly from Asian countries. They pay big bucks to the governments of small island nations to plunder their waters, and pay little heed to international law. Foreign aid is evident throughout the island nations, and it mostly comes — surprise — from those countries that want access to the fisheries: Japan, Taiwan, Korea, China and the U.S. But virtually none of the aid trickles down to the common people, who have poor diets and terrible health problems as a result. So much could be accomplished with a strong preventive health program — especially if it could reach the kids in school.

As big as the problems are, these are wonderful people who have taught me so much. They frequently told me that the quality of life is more important than the longevity of life.

Majuro recently got some negative sailing press because of a series of thefts from yachts. These small island communities are virtually crime-free because everyone knows everyone else, and there are no secrets. What I observed was more along the lines of teenage pranks and petty thievery. And there were alcohol-related incidents, too. Nonetheless, Kim and I have felt safer out in the Pacific, even more so than in Mexico, which we loved and will return to, to say nothing of San Francisco or Los Angeles. There are no guns in the Pacific Islands.

I am currently solo atoll hopping back to Fiji, where I will hopefully reconnect with Kim in early July. We're thinking about then heading to Vanuatu, and then the Solomons for the '12 Pacific Arts Festival.

—jim 05/05/11

**Azure II — Leopard 47
The Pimentel Family
Greece
(Alameda)**

We — Rodney, Jane, and sons RJ and Leo — have just motored through the



3.9-mile Corinth Canal, which connects the Gulf of Corinth and the Saronic Gulf and which saved us from having to travel 450 miles around the Peloponnesus peninsula to get to Athens. The canal was started by Emperor Nero in 67 AD, but wasn't finished until the late 1800s by a French engineering company. Unusually, there is a hydraulically operated roadbed at each end of the canal that, instead of lifting up, sinks down into the water to let traffic pass over the waters of the canal. Cars sometimes have to wait up to an hour to get across. But when the bridge lifts up, children can often run out and catch fish that got trapped on the bridge.

We had a five-hour passage before getting to the entrance to the canal, at which point we radioed the canal office for clearance and waited for a few other boats to finish coming the other way. As we waited, a small group — five sailboats, two barges, a small motorboat and a super yacht — gathered around



AUSPICE

IN LATITUDES



PHOTOS COURTESY AZURE II

Spread; The 3.9 mile Corinth Canal. Insets: An aerial view of the canal, and 'Azure II' anchored off another beautiful Greek island.

the entrance. There was a long delay while a straggler on the other side of the canal finally made it through, and another delay as everyone got ready to start. The total waiting time was about two hours.

Then, one by one, we started motoring through the Canal, which has very steep walls that are as much as 150 feet high. Yet the canal is only 80 feet wide. Leo entertained himself swinging across the bow with a line hanging from the mast, then started playing 'fender walking', and then got into a fender fight with RJ. Jane recommends that mothers not permit this kind of activity.

After tying to the exit dock at the other end of the canal, we paid our fee of \$340 U.S. — which comes out to almost \$100/mile.

After transiting the canal, we headed for the islands near Athens. We wanted

to visit Athens, but decided it was preferable to berth at an island and take a ferry to the city rather than try to find a berth in the city. We first went to the island of Aigina, a popular weekend tourist spot for Athenians. It was a treat to provision at the large supermarket, as we actually found things like maple syrup, which we hadn't seen since arriving in the Med. Based on the cost, it's like liquid gold and therefore strictly rationed.

The ferry to Athens took 45 minutes, and we somehow packed in a few days of errands and sightseeing into one long day. The new Acropolis Museum was amazing, with glass underfoot that enables you to see the excavations below. From the museum, you can look through the huge windows at the ruins, and see what's left on the Acropolis after more than 2,500 years.

Our six weeks in Greece has agreed with us, and we're glad we have more time here. The people have been exceptionally friendly, and the well-publicized ailing economy hasn't jumped out at us. Things actually seemed much more depressed in Italy. We're definitely not going hungry either, as munching on gyros and baklava is too easy. Healthier fresh fish and Greek salads are plentiful, too. The Greek wines, however, are as tasteless as everyone warned they would be. So we are savoring our stash of Italian wines.

The weather and water are starting to warm up, and we've finally had a few days of swimming. The boat is behaving — and sometimes the kids are, too.

— rodney and jane 06/05/11

Readers — The Charlie Chaplin-style video the Pimentels made of their Corinth Canal transit is hilarious. Check it out by Googling 'Azure II + Pimentel'.

Leap of Faith — Antares 44 Cat Bob & Lynne Walsh Four Years Cruising the Carib (Carpenteria)

No one said cruising was going to be easy, but then nobody told us it was going to be quite so much fun!

My husband Bob and I, and our Aussie mix dog Mollie, have been cruising our 44-ft cat in the Eastern Caribbean for the past four years. Before heading to the tropics in the fall of '07, we agreed that

After a career of building luxury homes, Bob and Lynne decided to enjoy a stint of cruising on a luxury cat.



Veal, pork or lamb, all gyros are delicious.



CURTIS LEAP OF FAITH

CHANGES

safety at sea was essential. Knowing that it would normally be just Bob and I, and our dog, we both got certified for CPR.

Recently Bob had cause to use his training — on a goat! While making a routine beach landing, Mollie inadvertently herded a wild goat straight into the ocean. We called Mollie back to allow the goat to swim back to shore, but the freaked goat just continued out to sea. So Bob fired up the dinghy, chased the goat down, and herded it back toward the beach. All was going well, until just two feet from shore, when the goat slipped beneath the surface.

Bob jumped from the dinghy and hauled the goat onto the rocky shore. It wasn't breathing so Bob commenced CPR — no, not mouth-to-mouth! — but by pumping his chest and slapping his face. The goat coughed up salt water almost immediately, but then passed out again. Bob continued his CPR efforts until finally the goat let out a little "baaayyyy", and we both felt tremendous relief. We continued to soothe and stroke the goat until he finally was able to regain his wobbly legs and teeter off into the bushes.

Our having retired from building custom homes, before Bob and I set out, finding the right boat for us was a labor of love. But when we stepped onto the Antares 44 at the Miami Boat Show, we instantly knew that we'd found what we had been looking for. The layout was *Ille des Saintes, just south of Guadeloupe, is composed of two main islands and six rocks — all very French.*

the first thing that connected for me. The cockpit can be wide open or fully enclosed, and the spacious helm station makes it comfortable for long passages. Additionally, the 'galley down' in the port hull allows for an unusually large and well-appointed galley. The fit and finish were especially crucial for us, and the level of detail in the Antares made us feel as though we were still living in a custom home.

After taking delivery, we slowly worked our way through the Bahamas, enjoying those magnificent and unspoiled islands. We made it to Georgetown, also known as 'Chicken Harbor', because it's the last stop before the real passage-making begins, and therefore where a lot of cruisers who had intended to sail to the Caribbean chicken out. But we pressed on to the Virgin Islands, where we found the extra effort to get there was well worth it.

Thanks to the islands that protect the Sir Francis Drake Channel from the open ocean swells, there is great and easy flat-water sailing in the easterly trades. This last year we were able to spend enough time in the Virgins to discover out-of-the-way anchorages that seemed as though they'd been forgotten by time. We'd share these locations with you, but then they'd lose their undiscovered charm!

In addition to the fine sailing in the Virgins, there is also great snorkeling, scuba diving, kayaking, and hiking on the many trails ashore.

Both the U.S. and British Virgins offer the easy lifestyle. In the BVIs, for instance, you can easily sail into Road Harbor, Tortola, walk from the anchorage to a selection of markets, provision your boat, and be back on the boat within an hour. Set sail, and another hour later you can be dangling on the hook in a quiet anchorage, appreciating another beautiful sunset with a cool drink.

The many different Caribbean islands offer such a variety of experiences, and each has its own allure, so it's hard to decide where to go. But we must admit that the French islands are among our favorites, thanks to their patisseries, delectable assortment of imported cheeses, and shopping for clothes. And the locals have proven to be quite gracious, by maintaining a friendly and helpful demeanor — despite our inadvertently butchering their beautiful



language!

And yes, the language did cause us a few problems. For example, during our first visit to Ille des Saints, we needed some fuel for the dinghy, but when we got to the pumps, we had to choose between 'gazole' and 'essence'. After several moments of head scratching, we chose gazole because it sounded the most like gasoline. Alas, gazole is diesel. We can assure everyone that Honda gasoline outboards do not like to be run on diesel. Ours got us to the middle of the anchorage before it let out a big belch of black smoke and quit.

Living aboard a boat for extended periods of time is unlike anything we expected or experienced, and has its minor hardships, but there are many rewards in being able to explore the many beautiful islands, and each day has offered us the opportunity to understand their rich histories and meet the friendly locals. And we never tire of swimming in the warm, clear, turquoise waters. But best of all, we've developed friendships with

LATITUDE/RICHARD



French St. Martin.

FRENCH FOTO



IN LATITUDES



COURTESY ANTARES CATS

Like most catamaran owners, Bob and Lynne are big fans of the generous space on deck and inside the boat. This photo is of a sistership.

fellow cruisers that we expect will last a lifetime. We think you can expect these gifts, too, if you only have the courage to take your own *Leap Of Faith*.

— lynne 04/15/11

**Cat 'n About — Gemini 3000
Rob and Linda Jones
Glad We Went With What We Had
(Whidbey Island, WA)**

In the June issue of *Latitude*, there was a *Changes* about our cruising to 10 countries in seven years aboard our Gemini 3000. The publisher subsequently asked us for our views about ocean cruising on a relatively small cat. First, we'll explain why we did it, and second, how it worked out.

We purchased our Gemini 17 years ago, with the intention of buying a bigger cat when we were ready to go cruising. However, we decided to leave a little earlier. Once our daughter graduated from

high school and moved out, our friends told us, "Oh, she'll be back." Not wanting to be tied down, we quit our jobs, sold the house, got rid of everything else, and took off cruising.

Sure, we could have stayed and worked for another seven years — but we would have missed out on all the fun. We have not regretted our decision to go earlier on a smaller cat. Of course there have been times when we wished we had a bigger boat, usually when the weather has been bad. But with careful passage planning, it's been possible to avoid bad weather most of the time. It's also important to remember there are downsides to owning bigger boats: they are more expensive, they require more maintenance, and the systems are more complicated.

Ours is one of the few long distance cruising

boats that is powered by an outboard — a Honda 25. Our Gemini only carries 20 gallons of fuel in the built-in tanks, so we carry 50 more gallons in jerry jugs. Our 800-mile passage from Costa Rica to the Galapagos was in very light air, so we needed every drop of that fuel. And while twin diesels with lots of tankage might have been ideal — and much more expensive — we've nonetheless managed with just a single outboard.



A single Honda 25 has been good for 10,000 ocean miles.

Without a diesel(s) and alternators to create lots of a power, we have three solar panels on an arch that keep the batteries topped off. We have a 1000-watt inverter for 110-volt power. For the rare occasions when we need more 110-volt power, we have a portable Honda 2000 gas generator.

Cats are weight sensitive, so we only carry 50 gallons of water. We then make what we need with our PUR 80 water-maker. Although we're careful about weight, we do indulge ourselves in some instances. For example, we're from Seattle and enjoy a good espresso, so we have an espresso machine aboard.

We sleep on a queen-sized bed in the forward stateroom, converted one aft cabin to a storage area, and keep one of the aft staterooms open for guests. We have one friend who has crewed with us a lot, and he reports he's been quite happy with his cabin.

No matter what size boat you have, it's important to have the right guests. For if you have the wrong people, even

Take off years earlier on a small boat than they could have on a larger boat? Rob and Linda have no regrets.



COURTESY CAN 'N ABOUT

CHANGES

a very large boat suddenly can seem too small. Many *Latitude* readers have probably heard the adage, 'six for drinks, four for dinner, and two for sleeping over'. We think that's perfect, no matter what size cruising boat you might have. And the Gemini has a nice sized cockpit for entertaining

That said, 99% of the time it's been



The Jones' small cat did well in big seas.

just the two of us aboard *Cat 'n About*, and it's worked well. We're also happy with the way she's handled rough weather. When we sailed south in '04, we had 45-knot winds with 12-foot seas off the Oregon coast. Our Gemini 3000 handled it well.

Sailing up-wind against strong winds and big seas is, of course, a different matter. It's not our idea of fun, and our Gemini definitely doesn't like it. So if that's the type of sailing somebody wants to do, ours isn't the cat for them. But then most cats probably aren't. Having traveled more than 10,000 ocean miles with *Cat 'n About*, our opinion is that she's a great boat. We've been very happy with her.

We cruised full time for five of the first seven years, but for the last two years have been running a megayacht five months a year for a couple who like to cruise the Northwest in the summer. Our being from the Northwest, this is fun for us — although when there are just two of you running a 112-ft yacht, you wear many hats and are on 24/7.

For our first five years of cruising, our budget was \$1,000 U.S. a month. And it

After five years of full time cruising, the Jones now run a large motoryacht in the Northwest in the summers. The best of both worlds?

wasn't a problem sticking to it. Having 'commuter cruised' the last two years, our expenses have gone up because of air fares, boat storage, and just being back in the expensive United States. So when we're done working for the season, we immediately fly back to our boat so we don't fall into bad habits of spending on stuff we don't really want or need. Last season we blinked, and we went way over our monthly budget by walking out of an Apple store with a new iPad and iPod Touch — which are two very cool toys.

The point is, you can have a very fulfilling life while spending much less money when you live outside the United States. In the future, we will split our time between work, sailing in Mexico, and spending time at our little house in Guatemala, where we'll also do volunteer work.

By the way, the Ha-Ha remains one of our most fun memories in all the cruising we've done.

— rob and linda 05/15/11

Cruise Notes:

"What a fabulous spring we had in the Sea of Cortez," write Diana and Roger Frizzelle of the Alameda-based Catalina 470 **Di's Dream**. "After five Ha-Ha's, we didn't think it could get any better, but it did. Due to time constraints and other commitments, we couldn't go any farther north than Santa Rosalia, but Conception Bay and all the other anchorages on the way up were incredible. The water was fantastic, particularly after it reached our 80° threshold. And we love the fact that unlike on the mainland, there is no surf in the Sea, so we didn't have to make any wild beach landings. We're leaving *Di's Dream* down here for a few months, but will return in October to work south again after December's Banderas Bay Blast. P.S. We're so sorry about the passing of Rui Luis of Rooster Sails in Alameda. He was a good and gentle friend, and had a wonderful wit."

"I thought I was just going to sail to Mexico for the winter, but the people and culture of both Mexico and *gringo* cruisers has kept me here for six months," reports Ed Skeels of the Alameda-based O'Day 25 **Dos Gatos**. "But now that my tourist visa is about to expire, I'm going to set sail for Hawaii as soon as **Hurricane Adrian** passes by. I expect that it will take



at least 26 days. Later I will sail back to San Francisco.

"My boat is small and was cheaply built in '78," continues Skeels, "so I stripped her to bare plastic in '01, then re-glassed and reinforced her. I also replaced all her bits and her spar. With all the cruising gear, she's about 500 pounds overweight, and therefore a little boggy in light-air swells. My shortest 24-hour run has been 90 miles, but I've also have 24-hour runs of up to 140 miles. My boat was not designed for motoring, so either I sail or I stay home. I got some condescending attitudes about my boat's size from a few people before I left California, but nothing has broken and I've taken no water in the boat other than spray. That's better than some 'well-found boats' that I've seen along the way. And while my boat is admittedly cramped and doesn't have the ride of a larger boat, she's paid for and I know how to handle her. Furthermore, while in Mag Bay I met a Danish couple who sailed their 26-ft **Bika** all the way from Denmark, so I know what small boats can do."





SPREAD, LATITUDE/RICHARD; INSET, DI'S DREAM

Spread; We can't imagine why Roger and Di don't miss the beach landings and take-offs of mainland Mexico. Inset; Aqua Verde.

Having recently adopted two cats to go along with the one he already had, Skeels admits that he's entered "crazy cat person territory."

The **Mexico / Eastern Pacific hurricane season** began on June 1, and first up was *Adrian*, which like most early and late season Mexican hurricanes started developing well offshore near the Guatemalan border. With 120-knot winds, *Adrian* reached Category 4 (on a hurricane scale of 1 to 5) status on her northwest offshore track before simmering down to 20 knots hundreds of miles west of Puerto Vallarta. The rhumbline course from Cabo to Hawaii is WSW, which means there is a pretty decent chance that hurricanes, tropical storms or their remnants will cross that rhumbline. While it's true that none did in '10, 11 of them did in '09, including three hurricanes. So we hope Skeels and others sailing from Mexico to Hawaii after June 1 are careful or lucky.

Wayne Hendryx apparently can't get

enough of sailing his and Carol Baggerly's Brisbane-based Hughes 45 cat **Capricorn Cat**. So after three seasons of back-and-forth between Mexico and California, Hendryx took off in early June from La Paz for Hawaii, while Carol gets in a session with the grandkids back home. "I'm only going to be in Hawaii for about a month or two," laughs Wayne, "and will then sail back to California to get ready for the Ha-Ha."

It's not Hendryx's first trip to Hawaii. About 40 years ago he and a couple of friends sailed a 25-ft Pearson Ariel from San Francisco to Hawaii and back.

If sailing 4,500 miles seems like a long way to go for just six weeks in the Islands, that's nothing compared to what Ha-Ha and Doo-Dah vet Doug Thorne of the Alameda-based Celestial 48 **Tamara Lee Ann** is doing right now. He and a crew were to leave Alameda in mid-June for a passage to Hawaii. Thorne will then fly home for a couple of weeks of work, then after only a

week or so of sailing in the Islands, will sail back to California with another crew. "I just like to be out at sea," he told us.

Several times over the last few months we've reported that Fiji and Tonga are waging a battle over who controls **Minerva Reef**, which is a mostly submerged tiny bit of reef that provides the only protection for cruisers between Tonga/Fiji and New Zealand. Vessels from the Fijian Navy have gone so far as to force cruisers to leave the shelter, and now **Cirrus**, of Takaka, New Zealand, is reporting that the Fijian Navy has destroyed navigation beacons in the area. It would seem like a reasonable idea to give Minerva a wide berth until the situation there improves.



There's a big stink on over little Minerva.

Nancy Potter Tompkins reports that husband 'Commodore' has been cruising Micronesia for the last bunch of months aboard their Mill Valley-based Wylie 38+ **Flashgirl**, and that she was just about to fly to meet him in Pohnpei, one of the four states of the Federated States of Micronesia. With 300 inches of rain, Pohnpei is one of the wettest places on the planet.

"We'll be sailing back to New Zealand by November," says Nancy, "but I want everyone to be on notice that I'll be hosting an 80th birthday party for Commodore at the Presidio YC late next February. Yes, he's been sailing on the world's oceans for more than 79 years, starting out as a newborn baby kept in a drawer in the famous pilot schooner **Wander Bird**. Commodore survived a heart attack many years ago, but is so into *Flashgirl* that when he started ex-

'Commodore', styling in the South Pacific as only a man who has spent 79 years sailing the oceans of the world can.



NANCY TOMPKINS

CHANGES

periencing persistent chest pains back in the States, he still couldn't decide where to go first: Svendsen's in Alameda for boat parts, or the Kaiser Hospital in Marin County. While he decided that a visit to Svendsen's deserved top priority, he was lucky enough to make it to Kaiser to get four stents put in. I'll have to say this for Kaiser, our co-pay for the four stents and everything else was only about \$500. Armed with the stents, Commodore has subsequently been doing great singlehanded around Micronesia, and I can't wait to join him."

Talk about your good gigs, multiple Ha-Ha vet and "slow delivery captain" **Bill Hardesty** called the other day to say that he was about to depart on a good sailing gig — a 'no rush' delivery of a Bavaria 44 from St. Thomas in the U.S. Virgins to Trinidad. It's about 350 miles as the crow flies, but easily 600 miles if one is going to make the delivery a pleasure cruise — as Hardesty plans to do. He was calling to ask which navigation app we thought was the best. We told him that our favorite to date has been **Navionics** on our iPhone and iPad — which we as-



NASA

This photo from a NASA satellite shows that St. John in the U.S. Virgins is mostly national park and that there are many great anchorages.

sume is also available on Droids such as his. Any other recommendations?

The only thing that could mess with Hardesty's trip would be an early season Caribbean tropical storm or hurricane. According to NOAA's Climate Prediction

Center, they expect **12 to 18 named storms, 6 to 10 hurricanes, and 3 to 6 major hurricanes** in the upcoming season. You can tell how confident they are in their forecast by the gigantic margin of error they give themselves. The Climate Center cited "above-normal sea surface temperatures, a weakening La Niña, and the effect of the warm regime of the Atlantic multidecadal oscillation" as the reasoning behind their forecast.

According to Colorado State University, between 1950 and 2000, there were **an average of 9.6 storms per season**, with a high being 28 and the low being 4. Let's just hope that this year's hurricane season will be as easy on boating interests in the Caribbean/Atlantic as they have been the last several years.

We love getting mail such as the following letter from Jonny Kaplan:

"In January of '06, you ran a story about a guy who bought a Kendall 32 in Long Beach, sailed her down to Punta Mita, where he'd done a lot of surfing, and was about — with his lady friend — to sail down to Ecuador for less crowded

HAWAII

LONG TERM DRY STORAGE

Clear Customs at our dock

**GENTRY'S
KONA MARINA**

HONOKOHAU HARBOR

156°1'30" W
19°40'20" N

TOLL FREE **888-458-7896**

www.gentryskonamarina.com

The friendliest boatyard in Hawaii

Mathiesen Marine

For all of your electronics and electrical needs

Sales & Installation of all major brands
of marine electronics



RAYMARINE
CERTIFIED
TECHNICIAN

Visit our showroom
Friday & Saturday
9:30 to 3:30 or
by appointment at



ABYC
CERTIFIED
MASTER
MARINE TECH



GARMIN
AUTHORIZED INSTALLER

Emergy Cove Yacht Harbor
3300 Powell Street, Emeryville



MARINE ELECTRICAL
MARINE CORROSION
MARINE SYSTEMS
ABYC STANDARDS

(510) 350-6622 www.MathiesenMarine.com

FAST SHIPPING!

NEW AND USED SAILS!

Specializing in production boats and featuring the largest selection of stock sails available anywhere! Save with warehouse volume discounts on Stock Sails, Custom Sails, Sail Covers, Furlers and Accessories. All top Quality.



**All Fully
Guaranteed!**

- Full Batten Mains
- Furling Genoa's
- Storm Jibs
- Trysails
- Furling Units
- Custom Canvas
- Used Sails

THE SAIL WAREHOUSE

Ph. (831) 646-5346 www.thesailwarehouse.com

VOLVO PENTA

ENGINES • PARTS • SERVICE

We Ship Anywhere **1-800-326-5135**

Call us for your nearest Volvo Penta dealer
1-800-326-5135



HELMUT'S
MARINE SERVICE

(415) 453-1001
FAX: (415) 453-8460
www.helmutsmarine.com
619 Canal Street
San Rafael, CA 94901

MARINE SERVICE INC

AUTHORIZED POWER CENTER

surfing. I had looked at that Kendall right before he bought her, but chose a Westsail 28 instead. But now, all these years later, I find that I'm still in love with that Kendall, and would like to contact the guy who bought her and see if he might be interested in selling. Do you have any info on him?"

Before doing any research, we wanted to find out more about Kaplan. He filled us in: "I live aboard my Vancouver 25 **Opah** in Marina del Rey, but I'm a musician and right now I'm on tour in Europe. But this is the year I'd like to find my dream boat, which would be a Kendall 32 or a Westsail 32."

We knew right away that Kaplan was referring to Robert Crozier and Marta Mijelman of **Pacific Spirit**, whom we covered in the January '06 *Changes*. Crozier had lived a wild and admittedly self-destructive life, but after a couple of lost decades had managed a miraculous recovery to the point where he and his lady friend were all about surfing, sailing and eating the most healthy foods available. The total natural life. A month

later we received a note from them saying they had indeed left for Ecuador, but haven't heard from them since. If you're out there Robert, and you still own your Kendall, and you might want to sell her, contact Jonny at www.jonnykaplanmusic.com. If anyone checks Jonny's website, they'll find that he's a life-long musician who has played with many of the greats, but who has found the most success in Europe. We wish him the best of luck on his boat search.

In a historical note, the Kendall 32 was a mild success in the early '70s, but thanks to a brilliant marketing campaign, was eclipsed by the Westsail 32, which launched an entire sailing movement.



Robert Crozier and Marta Mijelman pose aboard 'Pacific Spirit' on the hook off Punta Mita in '06 just before leaving for Ecuador.

Yes, the Aussies are still coming to California to buy boats! Among the latest are 'Verdo' and Gabriela Verdon, who recently sold their house in the Noosa area of Queensland, Australia. Of all the boats in the world, the one that caught their eye was the Catalina 42 **Ohana Kai**, which had been circumnavigated by the

Your Boatyard in the Heart of Paradise



Large, fenced, secure dry storage area

Tahiti Customs policy has changed!
Foreign Flag vessels can stay on dry storage in our yard for up to 12 months out of 24.

Our Services |

HAULOUT

- Marine Travelift 25 tons
- Marine railway 120 tons
- Storage in adjustable steel cradles
- Fenced Yard

PAINTING

- Topsides, hull, bottom, varnish
- Brush, roller, spray

MECHANICAL WORK

- Inboard, outboard, diesel, gas
- All brands

REPAIRS

- Electrical repairs
- Refrigeration installation & repair
- Fiberglass & woodwork
- Welding, steel, stainless, aluminum

SAIL LOFT

- Sail repairs, biminis, dodgers, covers

STORE

- International, Pettit, Epiglass, Devoe
- Spares
- Fill U.S. gas cylinders

DO-IT-YOURSELFERS WELCOME!

BoatUS Cooperating Marina



Professional boatyard in the heart of Paradise



A Subsidiary of
The Moorings Yacht Charter, Ltd.

Raiatea Carenage will make sure
paradise is everything you expected.
Call, write, or sail in . . . we're here to serve you.

B.P. 1111 Uturoa Raiatea 98 735 Polynésie Française

Tel: (689) 600-545 ~ Fax: (689) 600-546 ~ VHF 68

Web site: <http://www.raiatea.com/carenage> ~ email: raiateacarenage@mail.pf

CHANGES

Martin family of Seattle, and was thus already equipped with all the cruising gear the Verdots want. It's something of a coincidence that the couple bought the boat locally, as they are very close friends of Dona de Mallorca, and the trio enjoyed many wild days of their youth in Palma and on big boats in the Med. Verdo, who has run a series of large yachts for many years, keeps mumbling to himself, "I just can't believe that we're buying a production boat!" As for Gabriela, who had important positions for both the Oracle and Alinghi America's Cup teams in Valencia, she's just thrilled at the prospect of being able to move aboard her new home about 10 days after first setting eyes on the Catalina 42. Having pretty much had their fill of the more populated areas of the world, the couple are looking to cruise the still unspoiled areas of the South Pacific, such as the Solomon Islands.

There was a time — before GPS and other cruising conveniences — when a **circumnavigation** was a pretty unusual accomplishment. It's still something to be very proud of, but it's no longer that unusual. For example, Jim Elfers, Har-



LATITUDE/NICK

Verdo and Gabriela, with a world of sailing experience around the world, came to Alameda to buy their cruising boat.

bormaster at **Puerto Los Cabos Marina** in San Jose del Cabo, wrote to say that he recently enjoyed dinner with the crews of three boats that had just completed circumnavigations, and a fourth boat

that had gone around had just passed through. "The three were Nikki Friend and Gar Duke of the Sausalito-based Pacific Seacraft 40 **DreamKeeper**; Uwe Dobers, Anne Crowley, and 8-year-old daughter Kara Dobers of the San Francisco-based Peterson 44 **Magnum**; and Cindy Holmes and Faith Tamarin of the San Francisco-based **Carmen Miranda**," wrote Elfers. "The previous circumnavigators who passed through a couple of weeks before were the Mather family aboard the Redondo Beach-based DownEast 45 **Blue Sky**, who completed a seven-year circumnavigation with their children Phoebe and Drake. I had them over to my place several times to swim with my kids, and we'd play the Electric Light Orchestra's *Mr. Blue Sky* on the car stereo as loud as it would go. Loved it!"

Elfers reports that **Puerto Los Cabos** has 180 operational slips, 30 of them at a discounted price — \$40 for boats under 40 feet, \$50/night for boats over 40 feet — because they don't have electricity. Elfers says these have proved so popular with cruising sailors that he often sells out. The author of the **Baja**



EFFICIENT. POWERFUL.
UNSURPASSED CUSTOMER SERVICE.

www.spectrawatermakers.com



Check out our website!

Scan with your Smart Phone

GOLDEN STATE DIESEL MARINE

PARTS

YANMAR • UNIVERSAL • WESTERBEKE
PERKINS • ISUZU • PATHFINDER • ATOMIC 4

SERVICE

DIESEL ENGINES

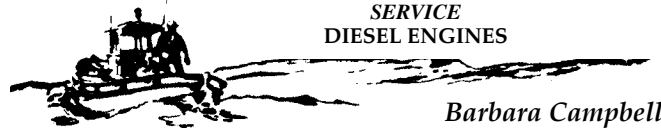

Barbara Campbell

351 EMBARCADERO
OAKLAND, CA 94606

(510) 465-1093

ATLANTIC 57 CATAMARAN™



THE ORIGINAL PILOTHOUSE CATAMARAN
o Designed for easy shorthanded cruising
o Spectacular windward performance
o Cored epoxy/glass/carbon construction

CHRIS WHITE DESIGNS
TEL: 508-636-6111
www.chriswhitedesigns.com

QUALITY CRUISING SAILS FOR LESS!



**MAINSAILS
MIZZENS
STAYSAILS
HEADSAILS
SPINNAKERS
SAILCOVERS
STRONGTRACK**

(707) 386-2490 • leesailscal@yahoo.com

2021 Alaska Packer Pl. • Grand Marina • Alameda, CA 94501

SAILMAKER TO THE WORLD

Bash, Elfers still sells autographed copies to folks coming through. As for this year's Bashing, he says the last couple of months have been normal — which means pretty rough.

"After enjoying the '10 Ha-Ha and cruising the mainland as far south as Barra, we accepted the invitation of sailing enthusiast Enrique Tovoillo of Mexico City to be crew on his J/24 **Copalago** on Valle de Bravo Lake, 100 miles from Mexico City," report Lisa Goldman and Neil Coleman of the Marina del Rey-based Young Son 35 **Gypsy**. "We accepted the invitation and sailed against some of the best sailors in Mexico, and also got to meet the sailing instructor for Felipe Calderon, the President of Mexico. Who knew he was such a sailing enthusiast? After an amazing weekend of sailing and enjoying ourselves at Enrique's awesome lake home, we got to stay at his beautiful Zona Rosa apartment in Mexico City. We took advantage of the opportunity to explore the amazing city, where Lisa had lived and studied back in the '80s. While there, we got news that a tsunami was expected at the Barra de Navidad Marina

where we'd left *Gypsy*. We watched the Mexican news on TV, and made daily calls to the marina, only to be told, "Your boat is fine." Thank goodness she was, and for the sailblogs, because fellow cruisers were the only ones providing accurate information. We returned to find that *Gypsy* was just as we had left her, except for a few marks on the fenders. As for our friend Enrique, look for him in this year's Baja Ha-Ha with his Catalina 37.

As if to prove how small the world of sailing is, Jane Pimentel of the Alameda-based Leopard 47 **Azure II** reports that while she and her family were at Sifnos, one of the least touristy of Greece's Cyclades islands, they "ran into **Eugenie Russell**, well-known skipper from Puerto Vallarta, the Ha-Ha, and a few years before that, Alameda. Eugenie



They say it's good to be 'green', but shots such as this — with your boat anchored off a taverna in Greece — make us green with envy.

was skippering a charterboat and sailing with Richard and Ursula, a couple of her students from the Bay Area. I've been in awe of Eugenie after reading about all her sailing exploits."

"This is our first season of cruising, and while we planned on going as far south as Z-town, we actually only made it as far as Bahia de Santiago," report Larry VanderWall and Melanie Montilla of the Alameda-based Hardin 45 **Hemi-**

Mexico Summer Savings

ENJOY MARINA EL CID at just \$.30/ft. day



*Complete, modern amenities
in the heart of Mexico's lush
tropical coastline.*

www.elcid.com
011-52 (669) 916-3468
gcevallos@marinaelcidmazatlan.com

The Cruiser's Home in Mexico



Save Your Aft!

Using one of our 1900+ patterns or your own pattern, let our craftsmen create a comfortable, durable, and stylish set of all-weather cushions for your cockpit. Find your custom, closed cell foam cushions at www.bottomsiders.com!

BottomSiders

BottomSiders
2305 Bay Avenue
Hoquiam, WA 98550

Call Toll Free: (800) 438-0633
cushions@bottomsiders.com
Fax: 360-533-4474

Let Hydrovane sail you home safely.



▲ Polar circumnavigator Adrian Flanagan.



Latest ARC survey —
Hydrovane again the
most popular wind vane.

Totally independent
self-steering system and
emergency rudder...
in place and ready to go.

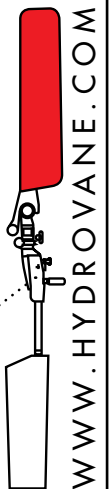

WWW.HYDROVANE.COM



SURVIVE YOUR DREAM

info@hydrovane.com PHONE 1.604.925.2660

CHANGES IN LATITUDES

sphere Dancer. We were just having too much fun and seeing too many great things to get any farther south. Maybe next year. This year's highlight was our 1,500-mile road trip to see the lava-buried church by Volcan Paricutin, Colonial Patzcuaro, the ruins at Tzintzuntzan, the artistic city of Morelia, and the millions of monarch butterflies just above Zitacuaro. We ended up going through three different military checkpoints to get to these places. There were lots of guns, but there was professional courtesy all around. At the last checkpoint, they even had us fill out a survey to rate how they did! They are trying to be tough on the drug problem, but easy on the people. What a concept! The folks at Customs and Immigration in San Diego could pick up a few pointers from the Mexicans.

Given that it's summer, a lot of *Latitude* readers are probably wondering if Andrew Vik of San Francisco will be returning to his Islander 36 **Geja** in the Med to flirt with lovely young women for the fourth year in a row. "Yup," Andrew



Few Bay Area sailors have worked as hard as Andrew to further international relations.

writes, "I'll be doing six weeks of sailing in the Adriatic from July 9 to August 20, which is the peak season. You can follow my route at <http://sailgeja.com>. I've got other crazy news, too. I've been chosen to be on a Norwegian reality dating show that will be shooting in San Francisco in the fall."

Giles Findlayson of the Encinitas-based Newport 41 **Petrel**, the courageous sailor who nearly lost both arms and his life when the dinghy he was riding in was run over by a Malaysian fishing boat in Langkawi in '09, reports that he's "come a long way" since the accident, has had some more physio Down Under,

and just returned from a second trip to his boat in Langkawi. This good friend of *Latitude* would like everyone to know that his **Island-to-Island Waterman Relay**, from Santa Barbara Island to Two Harbors on Catalina for SUPs, paddleboards and OC1s, has been

revived as a charity for the City of Hope. It will be held on October 8, the weekend after Buccaneer Days at Two Harbors. In addition to having gotten four years into a solo circumnavigation before the terrible accident, Findlayson had paddled from Catalina to the mainland more than 30 times.

Speaking of **Two Harbors**, the Santa Catalina Island Company has announced that their 700 moorings can now be reserved and paid for online. For a mooring Sunday through Thursday, you can make a reservation 90 days in advance. For moorings for Friday, Saturday and holidays, you have to wait until just after midnight on Thursday. For details on the program, see www.visittwoharbors.com.

— latitude



Arunga

Jim DeWitt

Jim DeWitt has been painting his entire life. And since he turned 81 this year, he has had plenty of practice!

Contact Pam in Point Richmond for details on commissioning Jim to paint anything you treasure!

DeWitt Art Gallery & Framing

121 Park Place, Point Richmond, CA 94801

(510) 236-1401 • www.jimdewitt.com • www.dewittgalleryandframing.com

Wednesday-Saturday 11:00-7:00 • Sunday 9:30-5:30

You're invited to...

Drop Anchor at the Pittsburg Marina!

- NEW GUEST DOCKS
- NEW FUEL DOCKS
- Valvtect Marine Fuels
- Saturday Farmer's Market in the summer
- Delta Discovery Cruises
- Many nearby restaurants



(925) 439-4958
www.pittsburgmarina.com

51 Marina Blvd. ~ Suite E
Pittsburg, CA 94565



MARINE ENGINE CO.

WESTERBEKE **Universal** **BETA MARINE**
DIESEL MARINE ENGINES

LICENSED DEALER FOR ABOVE

PERKINS • YANMAR • ATOMIC 4 • VOLVO

CALL NOW FOR LOW ENGINE QUOTES

- Engine Sales, Service and Parts
- Engine Repowering and Rebuilding
- Complete Marine Engine Service

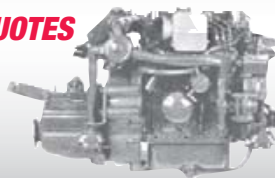

(415) 332-0455

Boat Loans



Marine Financial Services

Same people, same places,
new name, new look!

Dimen Financial is now
Sterling Associates. Now
you can look to Sterling for
the best rates and terms.



Northern
California

Bill Kinstler

(866) 486-2628

bill.boatloans@gmail.com

KATADYN SURVIVOR 35 WATERMAKER

The Survivor is a must for all sea-going vessels and is the most widely used emergency desalinator. It is used by the U.S. and international forces. It is able to produce 4.5 liters of drinkable water per hour. These are unused U.S. government surplus.

Reconditioned by Katadyn **\$950.**
Compare to factory new price: \$1,995.

For more information or
to place an order, please
call one of our sales reps.

Equipment Parts Sales
In the U.S.: (800) 417-2279
Outside the U.S.: (717) 896-9110



COMPUTER ABOARD?

CAPN & Digital Charts
AIS • WiFi • Cellular Amps
SatPhones: Iridium & Globalstar
HF SSB Radio & Pactor Modems
Wireless E-mail



SEATECH SYSTEMS™

800.444.2581 • 281.334.1174
info@sea-tech.com • www.sea-tech.com

Call for Info on SeaTech Packages and CAPN Demo Disk

Please read before submitting ad

Classy CLASSIFIEDS

Here's What To Do:

Write your ad. Indicate category. Remember price and contact info. We make final placement determination.

Count the words. Anything with a space before and after counts as one word. We will spell-check, abbreviate, edit, as necessary.

Mail your ad with check or money order, deliver to our office; **OR, for the best – and most exposure – of your classified ad...**

Submit your ad safely online with Visa, MasterCard or AmEx at: **www.latitude38.com**

Ad will be posted online within two business days, appear in the next issue of the magazine, and remain online until the following issue is released.

PERSONAL ADS

1-40 Words.....\$40
41-80 Words.....\$65
81-120 Words....\$90
Photo.....\$30

• Personal Advertising Only •
No business or promo ads except Non-Profit, Job Op, Business Op

'Trying to Locate' Ads are for those searching for lost boats/people – not shopping – and cost **\$10 for 20 words max**

FREE Online Ads are for a private party selling a boat for less than \$1,000 – or gear totalling under \$1,000. (One per person; must list prices in ad.)

All ads will be set to fit *Latitude 38* standard • Re-Run Ads: Same price, same deadline

BUSINESS ADS

\$70 for 40 Words Max

• All promotional advertising •
1 boat per broker per issue
Logo OK, but no photos/reversals
No extra bold type • Max: 12 pt font
Artwork subject to editor approval.
Biz ads will not appear on website.

DEADLINE

is **ALWAYS** the **18th at 5 pm**

for ad to appear in the next issue.

Due to our short lead time, deadlines are very strict and include weekends & holidays.

Sorry, but...

- No ads accepted by phone
- No ads without payments
- No billing arrangements
- No verification of receipt
- We reserve the right to refuse poor quality photos or illegible ads.

Latitude 38 15 Locust Ave, Mill Valley, CA 94941 Questions? (415) 383-8200, ext 104 • class@latitude38.com

WHAT'S IN A DEADLINE? Our Classified Deadline has always been the 18th of the month, and it's still pretty much a brick wall if you want to get your ad into the magazine. But it's not so important anymore when it comes to getting exposure for your ad. With our new system, your ad gets posted to our website within a day or so of submission. Then it appears in the next issue of the magazine. So you're much better off if you submit or renew your ad early in the month. That way your ad begins to work for you immediately. There's no reason to wait for the last minute.

LIFERAFT VIKING UKL 4 MAN VALISE. 2009, Richmond. \$1,600. Offshore Type E pack equipment. 2009 meets ISO I, DNV, and BV. Currently certified. Next service is 4/2012. Also, 2011 watermaker, Katadyn Survivor 35 Manual. In original box. \$1,500. Contact (510) 932-5673 or dougissurveyor@hotmail.com.

9-FT AVON INFLATABLE MODEL 280. ribbed, 2004. Novato, California. \$2,995. 2007 Mercury 6-horse 4-cycle engine (a few hours). 4 preservers, 2 paddles, Caulkin trailer, spare tire and jack, bimini top, seat, ribbed, floor boards, very little use, great tender. (Contact 415) 713-3794 or sara@sarahenydesign.com.

10-FT WEST MARINE COMPACT RIB. and outboard motor, 2003. San Jose, CA. \$2,700. West Marine Compact RIB 310, excellent condition \$1,500. Mercury 6hp 4-stroke outboard motor, external tank, excellent condition \$1,200. Both stored indoors. (408) 644-5216.

8-FT OPTI MISTRAW 2007. Monterey/ Carmel. \$1,500. Vanguard Club Racer. Blade bag, good use. North sail. Boat in excellent condition.

24 FEET & UNDER

22-FT SANTANA. Coyote Point. \$1,000. Great Bay boat. Good shape and sails well. Longshaft outboard included. Genoa and standard jib. Contact (650) 328-2249 or christov61@me.com.



22-FT CATALINA, 1986. Benicia Marina. \$4,000. Fresh bottom (Jan 2011), very good condition, tandem trailer, older 5hp Mariner, pop-up, swing keel, new lifelines, 3 sails good condition, fresh teak. Terrific first boat. Contact (530) 756-5024 or dawn-mike@sbcglobal.net.

20-FT FLICKA, 1983. \$29,000. Diesel 670 hours, self-furling head sail, new galley, enclosed head, autopilot, 2 anchors, inverter, barbecue, MOMS, 2 bilge pumps, custom zipper sail cover, lazy jacks, excellent condition, full standing headroom. Captain getting too old. (831) 338-4233.



18-FT I550 SPORTSBOAT, 2010. Sacramento. \$13,500/obo. The deal on the Best "Bang for the Buck" sportboat available just got better. We are heading out cruising this fall so everything must go. Price dropped to \$13,500 or best offer. This boat is a TON of fun to sail. Race ready for PHRF, Portsmouth or class racing. Registered trailer included. www.bens-boogers.blogspot.com. (916) 470-9446 or bendoolittle@hotmail.com.

24-FT ISLANDER BAHAMA, 1968. Pittsburg Marina. \$3,000/obo. Excellent Bay and Delta cruiser. 4hp outboard, 2 mains, 2 jibs, and a genny. Sleeps 4, galley and PortaPotti. Lots of gear. Recent bottom paint. Compass, VHF, fishfinder. (707) 964-1898 or knxtime@comcast.net.

DINGHIES, LIFERAFTS AND ROWBOATS



15-FT CATALINA CORONADO, 1975. Huntington Beach, CA. \$2,100. Excellent condition, very clean, good sails. Lots of controls, color coded lines. Trapeze lines with harness. Galvanized trailer, canvas cover. easy daysailer or aggressive racer. (714) 244-8720.



8-FT MONTGOMERY. Delta Marina, Rio Vista, CA. \$1,100. Purchased new 9-28-1990 from Seabird Sailing & Rowing, Berkeley, CA, stored under cover since. Top quality construction. Length 7'11", beam 4'2", weight 84 lbs., height 1'11". Soft canvas carrying case, two wooden oars w/oarlocks, and much more. Call for details. (925) 934-0709.

WOODRUM MARINE

Specializing in custom interior cabinetry, tables, cabinets, countertops, cabinsoles. For power or sail.

CARPENTRY
Mobile cabinet shop
Contact Lon Woodrum at:
415-420-5970
www.woodrummarine.com

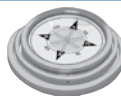

NOR-CAL COMPASS

Adjustment • Sales

Authorized Compass Repair

Hal McCormack • norcal.compass@verizon.net • Phone/Fax (415) 892-7177

N.E. MARINE TITLE

Coast Guard documentation • Title/lien searches • Transfers • Mortgage filing • Escrow services

Local closing facility for brokers or private transactions

30 years experience of doing it right the first time

1150 Ballena Blvd, Alameda, CA • (510) 521-4925

BOAT • LETTERING

alphaboatsue@aol.com • (510) 599-1197 • www.alphaboatgraphics.com

Creative and durable lettering and artwork for your boat



24-FT NEPTUNE, 1981. Santa Cruz, CA. \$3,995. Bottom paint 2010 over epoxied hull; Standing rigging 2007, tabernacle set up, ESSENTIAL for North Harbor access in Santa Cruz, Yamaha 6hp (100:1), KM, DF, VHF. Larsen sails (great shape). Lines led aft for easy singlehanding. Clean inside and out. I have owned and sailed this boat out of Santa Cruz for 17 years. Well maintained, ready to sail today. Many extras. Bought bigger boat, priced to sell. Contact (831) 588-3937 or tomhalderman@gmail.com.

26-FT RANGER, 1970. Fortman Marina, Alameda. \$4,200. Gary Mull design. New 135% headsail with Harken roller furling system 2007. Lazy jacks. New interior with custom gel cushions. New lifelines. Solid Bay boat. Ready to sail. Many extras. (925) 323-7081 or (209) 295-2270.



26-FT MACGREGOR 26X, 1997. Morro Bay State Park Marina. \$15,500/obo. 60hp Mercury Big Foot w/low hours and trailer. Golf, campground, restaurant across the street. Low monthly slip fee. Low transfer fee. Too much info to list. May trade for small RV. (805) 995-2640 or (805) 610-7397.



26-FT CONTESSA, 1973. Point Richmond. \$10,500. Boat is in solid working order. Great boat for on the Bay as well as distant ports. See John Vigor's *Twenty Small Boats to Take You Anywhere*. Contact sonar247-skipper@yahoo.com or (916) 202-5575.

27-FT ERICSON, 1971. San Diego. \$3,900. Tiller steering and O/B engine. Good shape and super stable. Visit website for details and photos at <http://ericson27insd.blogspot.com>. Email ericson27sd@gmail.com.



28-FT HUNTER 280, 1998. Tiburon. \$29,000. Original owner, pristine, power winch, 2 batteries and charger, autopilot, wind, speed, depth, Yanmar 18hp diesel (150 hrs), roller furler 110, rear winches, refurbished below, paint 2011, water heater, GPS, loaded. (415) 789-9522 or maccoffey@comcast.net.

25 TO 28 FEET



25-FT CATALINA C-250, 2000. Reno, Nevada. \$22,500. Excellent fresh water Tahoe boat. Wing keel, 9.9 Honda 4-stroke long shaft, Trail Rite trailer with mast raising system, CDI furler, 2 jibs, spinnaker, 2 anchors, canvas and cushion packages, pop top w/canvas, Edson wheel steering w/open cable upgrade, Ida sailor kick up rudder, enclosed marine head with holding tank, shore power, ST60 Tri-Data, Tacktick wind system, galley sink and stove, VHF radio, life sling, custom boat cover. Motivated seller. (775) 329-8543 or james3385@charter.net.



26-FT RANGER, 1978. Vallejo, CA. \$7,000. Tall rig. Two-year-old Nissan 9.8 four-stroke engine. Bottom in Dec, 2010. Jib and main, 1998. Rigging and life lines and deck paint, 2007. Battery, 2009, includes rescue lift. (707) 448-2040 or rs1186@aol.com.



CAL 2-25 / CAL 25 MK II, 1979. Alameda, CA. \$11,950 w/trailer. Make us an offer. Fiberglass sloop w/Yanmar diesel. Exceptionally well maintained one-family boat in freshwater until 2003. New sails / rigging 2004. Equipped with systems found on much larger boats. You'll be hard pressed to find better kept cleaner boat. All systems work! Fixed lead fin keel, raised cabin top. Beautiful varnished teak handrails, companionway rails, tiller, hatch boards. Details available upon request. Contact (408) 756-0370 or martythamm@aol.com.

27-FT HUNTER H27, 1989. South Lake Tahoe, CA. \$14,000. Has everything you need for family fun! Sails fast, sleeps 6, and is ready for you to enjoy NOW! Check out the website for photos and more details! <http://webpages.charter.net/tahoehunter270>. Email tahoehunter270@charter.net.

29 TO 31 FEET



27-FT ERICSON, 1978. Sausalito. \$8,500. Diesel, wheel, furling, autopilot, GPS, NEW: hatches, all rigging/lifelines, head, upholstery. Excellent condition. Ready to sail! www.flickr.com/photos/29512960/N07/sets/72157622552854149. Email cathouz@yahoo.com.

25-FT CATALINA, 1978. Vallejo. \$5,500. EZ-Load trailer, swing keel, pop top, Honda 9.9 4-stroke, brand new main, 4 headsails, balanced rudder, 2011 bottom job, new depth meter, VHF, solar panel, dinette, Porta-Potti. Boat is in great shape. Contact danielkaronis@sbcglobal.net or (707) 365-2291.



28-FT ALERION EXPRESS, 2007. Sausalito. \$89,000. *Lizbeth*. Hull #359, commissioned Jan. 2007. One of a kind, active fleet racer/winner. Factory teak and Ultrasuede interior, Tacktick instrumentation including NEMA interface, handheld remote, running rigging upgrades too extensive to list. Pineapple sails, Kevlar jib, asymmetrical spinnaker, removable Seldon carbon sprit, Lewmar 30 primary and secondary winches. Custom matching canvas including full boat cover, cockpit cushions, additional teak exterior trim, cockpit grate, more. A fully maintained and varnished yacht. Must see to appreciate. Contact (415) 608-6919 or miland2@ix.netcom.com.



30-FT OLSON 911SE, 1989. Pt. Richmond, CA. \$29,000. Fast racer/cruiser, well maintained, new standing rigging, recent sails: Quantum main, North jibs. GPS and speed/wind/depth instruments. Have roller furling jib gear. Contact (510) 260-6081 or (510) 234-2838 or craine.roger@gmail.com.



26-FT RANGER, 1972. Bodega Bay. \$4,750. New standing rigging, life lines, windows, cockpit cushions, and Tillerpilot in 2004. New Honda 9.9 outboard, new sails, roller furling, compass, and depth/knotmeter in 2003. Will deliver to SF Bay. (707) 823-3457 or euphonic@sonic.net.

30-FT ISLANDER BAHAMA, 1982. Alameda. \$12,900. Nice boat, good sails, chart plotter, BBQ, autopilot, fish finder, engine runs not at full speed. Lots of extras. Life vest, anchors, etc. Big Wheel steering. Located at Fortman Marina, 575 Jefferson St. n8cal@rocketmail.com.

30-FT BABA, 1980. Berkeley. \$45,000/obo. Beautiful, bluewater cruiser. Rebuilt Volvo diesel 70 hours. \$15k 2010 haulout: mast, re-rigged, barrier, furler jib, batteries, Cetol. Teak decks, windlass, autopilot, diesel heater, Bristol 6'6" interior. http://yachtsoffered.com/yachtsoffered.cfm?yachts_listingid=1291697&returntype=3. (510) 258-4053 or jchristianlloyd@yahoo.com.



RIGGING ONLY ■ SMALL AD, SMALL PRICES

Standing and running rigging, life lines, furling gear, winches, line, windlasses, travelers, wire and terminals, blocks, vang, and much more.
~ Problem solving and discount mail order since 1984 ~

www.riggingonly.com • (508) 992-0434 • sail@riggingonly.com

MARINE SURVEYS - Capt. Alan Hugenot

Accredited Marine Surveyor (since 2004) • (415) 531-6172
Yacht Master (USCG 200 tons - International) • Port Engineer •
Yacht Manager • Delivery Skipper • Boat Handling, Navigation
& Safety Instructor • Accepts MC & VISA



Jack D. Scullion
Yacht Services
jdsyachts@att.net
(510) 919-0001

Rigging
Electronics

Troubleshooting
Electrical Installations

We Gladly Install Gear You Provide

NEILPRYDE



SAILS



Rick Whiting • (415) 740-2924 • captain_rick@sbcglobal.net

STARBOARD YACHT DELIVERIES

Over 50,000 sea miles • Pacific, Caribbean, Atlantic
USCG Master 100 GT STCW • Power & Sail

30-FT OLSON, 1982. Santa Cruz. \$6,000. Ultralight boat. Double spreader rig, 10 bags of sails. 1.5hp outboard. Trailer. Needs work, great project boat. (831) 427-3032 or redsquid5@gmail.com.



30-FT TAHITI KETCH, 1949. Sausalito. \$34,500/obo. Kauri planked copper riveted to apitong. Ocean ready. Garmin GPSmap and HD radar, EPIRB, liferaft. Recent rig replacement. Reefer, replaced keelbolts and thru hulls/re-caulked. Rebuilt Yanmar 3GM. (415) 272-4203, 300 Napa St. #17. jody_boyle@yahoo.com.

30-FT CATALINA TALL RIG, 1982. Berkeley. \$21,500. Hauled out w/new bottom paint June. Exceptionally clean in/out. Dinghy w/3.5 & 9hp. Furling jib, main and spinnaker. Stern pulpit seating, custom interior woodwork many extras/w photos. (925) 687-3566 or (925) 330-2317 or thebushnells@comcast.net.



29-FT CAL, 1972. Novato. \$9,000. Great Bay/ocean cruiser/racer. New hull paint by pro. Atomic 4. Spinnaker and rigging, radial headsail (shown). 3 jibs (90, 110, 150), 7 winches, autopilot, digital depth and speedometer, 12V built-in refrigerator. Contact lagoonlyovers@sbcglobal.net or (415) 883-5365.



30-FT HUNTER SLOOP, 1993. Vallejo Boatyard. \$30,000 or cash+trade. This boat needs someone to sail it. In boatyard ready for inspection and a little TLC. Basically a one-owner with low engine miles. Interior is pristine. Quarterly maintenance by a diver, mostly original and used very little in the last 5 years. A nice find. When calling ask for Jill or John. Open to creative trades. Come see all the onboard extras and make an offer. (925) 228-7569 or (925) 957-6870 or jchioino@aol.com.

30-FT ONE DESIGN BIRD. Sausalito berth. \$14,500. Good condition. Tops in fleet. Just out of boatyard. (415) 302-7490.

30-FT NEWPORT II, 1979. San Francisco. \$17,000. Wheel steering, 16hp diesel, roller furling, main, 2 jibs, spinnaker all in VG condition. Autopilot, wind instruments, CNG SS stove, smart battery charger, inverter. Too much equipment to list. Email for list. SF Marina berth transferable. Contact (415) 564-5209 or bswanson1@sbcglobal.net.



30-FT LANCER C&C DESIGN, 1980. Marina Bay. \$25,000. Fractional sloop w/reliable Yanmar QM15 diesel engine. Redecorated cabin w/padded 6' head room, new cushion covers, tile counters, bamboo sole, appliances. Recently replaced electronics: speed, depth, VHF, GPS, chart plotter, CD stereo, 3 batteries w/trickle charger, bilge pump and instrument panel. Recently replaced on deck: mainsail and jib, safety lines, shrouds, traveler, dodger w/bimini, wheel pilot and roller furling. No blisters, recently hauled. Life jackets, tools, parts. She is a wonderful sailer and ready to go... Contact (916) 487-5351 or (916) 206-7556 or barronsdesign@surewest.net.

30-FT HUNTER 29.5, 1997. Tiburon. \$25,000. Clean, spacious interior, well maintained. Perfect for family outings or overnighting. Propane stove, oven, external fresh-water showers, swim platform. Three year-old sails in good shape plus asymmetrical spinnaker. (415) 994-0328 or kbelgum@gmail.com.

CS-30, 1985. Vallejo Yacht Club. \$29,000. Top quality Canadian racer/cruiser. Well maintained, Pineapple sails, new jib, reliable V-P diesel, extremely roomy 6'2" headroom. See website for full details, working overseas - no time to sail! <http://avocet.weebly.com>. (530) 389-4308 or svavocet@gmail.com.

CAL 2-29, 1975. Pt. Richmond. \$13,000. Great family cruiser for Delta, Bay, coast and club racing. Well maintained, fully equipped. Dry, updated interior, new stove, 3 batteries, wheel, Autohelm, dodger, swim ladder, VHF, GPS, spin. pole, sun shade, solar panel, Yanmar 18 diesel, folding prop, 2 anchors, buoy hook, windlass, and more. Full batten main, lazy jacks, roller furling, 155 genoa, new 110 and 125 jibs, replaced rigging and vang. Contact (925) 932-3679 or slbhdsgns@sbcglobal.net.



30-FT CHERUBINI HUNTER, 1978. Alameda, CA. \$14,000. Ample cabin room w/flawless interior. Reliable YSB12 12hp diesel. Wheel. Three headsails. New standing rigging '09. New Harken traveler '09. Sails like a dream. <http://picasaweb.google.com/Loughz/1978CherubiniHunter30Sailboat?authkey=Gv1sRgCJ6B7f6XprX5wE&fea>. (206) 618-6291 or LoughZS@Gmail.com.

30-FT CATALINA TALL, 1982. Stockton. \$27,800. Cherry clean, tiller pilot, loaded, newer everything, Low hours 2003 Universal 20 diesel, tranny and fuel tank, new 1500 watt Xantrex, Autohelm, Pineapple on Profurl, davits, hard dodger. New canvas. Pictures? (209) 614-4568 or (209) 846-1730 or deltasailing@hotmail.com.



30-FT CATALINA, 1976. Fortman, Alameda. \$18,600. Universal diesel 25 rebuilt 04/11, dodger, roller furling, spinnaker pole, VHF radio, two battery banks, H/C press. water, 2-burner stove/oven, microwave, refrigerator/12v and 120v, custom stern pulpit seats built-in, wheel steering, asymmetric spinnaker (Pineapple Sails), 130 XtraJib backup, dinghy w/9hp outboard. Boat has sailed to San Diego, in multiple Windjammer events, and up the Delta. Much more and a great value. (408) 219-4920 or steve@hulawyers.com.



29-FT LANCER POWERSAILER, 1985. Marina San Carlos, Guaymas, Mexico. \$25,000. I spent almost a year totally redesigning and rebuilding this boat. The link to my Craigslist ad lists most of its attributes. <http://phoenix.craigslist.org/evl/boa/2452263524.html>. (480) 968-4104 or buzoloco@aol.com.

29-FT FARALLON, 1972. Friday Harbor, Washington. \$15,000. Great cruising boat and liveaboard in sailing condition. Volvo power, 3-reef main, reefable working jib, genoa and drifter. All gear, dinghy and cradle included. One owner, documented. Strong construction, 45% ballast/displacement. Picture gallery available. axiulians@gmail.com.



33-FT RANGER, 1976. Alameda. \$12,500. Atomic Four. Roller furling jib. Hauled and painted 2010. Spinnaker and poles. Contact (925) 200-1950 or bobs@canamplumbing.com.

32 TO 35 FEET

35-FT J/105, 1997. Sausalito. \$79,000. J/105 #163, *Roxanne*, a proven race winner on the Bay, including Vallejo Race 2008, 2009, etc. Large sail inventory, full instruments, in excellent condition and ready to keep winning races. (415) 336-3367 or charlescjames@gmail.com.



32-FT ERICSON, 1969. Owl Harbor near Isleton. Best offer above \$9,000. Well built, well maintained older boat. Suitable for liveaboard or cruiser. New bottom paint. Holding tank, Atomic 4, autopilot, GPS, microwave, stereo, VHF, stove and barbecue on propane system, 5 sails. Contact (209) 572-2934 or phillips.fred5@gmail.com.

32-FT ERICSON, 1969. Owl Harbor near Isleton. Best offer above \$9,000. Well built, well maintained older boat. Suitable for liveaboard or cruiser. New bottom paint. Holding tank, Atomic 4, autopilot, GPS, microwave, stereo, VHF, stove and barbecue on propane system, 5 sails. Contact (209) 572-2934 or phillips.fred5@gmail.com.



MARINE SURVEYOR

Sharpe Surveying & Consulting. SAMS Accredited Marine Surveyor. Serving the San Francisco Bay and Delta.

RSharpe@SharpeSurveying.com • (510) 337-0706



MOBILE MARINE PUMP-OUT SERVICE

\$25 per pump up to 40 gallons. Includes fresh water flush and a packet of treatment. 20% discount for regularly scheduled service.

www.mobilepumpout.com • (415) 465-0149 • tim@mobilepumpout.com

FIBERGLASS REPAIR AND CONSTRUCTION

All water craft and boats. Excellent workmanship.

Any damage or new construction and modifications to your boat. (925) 628-0639 • grovecomposites@yahoo.com

boat bottom scrubbing & more . . .

415.331.SAIL william@gotzinc.com www.gotzinc.com



33-FT KALIK, 1980. Pier 39, San Francisco. \$12,750. Sleek baby Swan look masthead sloop with a coach roof cabin and semi-flush teak deck with deep fin keel and skegged spade rudder. Has brand new mainsail and 130 jib and 110 and 150 jibs, powered by 20hp 2-cylinder Yanmar diesel. Interior has private forehead cabin, four additional bunks, head, galley, dining and captains' tables. Only one owner, searching for someone to give it TLC. (415) 726-8870 or zulfi@cumali.com.

34-FT CAL, 1978. Brisbane. \$25,000/obo. Mark III edition. New 28hp Beta Marine engine and Schaefer 2100 roller furling. Raymarine wheel/pilot, Maxwell windlass, good sails, JRC radar and more. <http://lolitech.com>. (650) 224-4211 or stan.loll@gmail.com.



35-FT SANTANA, 1980. SF/Sausalito. \$18,000. 3 jibs, 3 mains, 3 spinnakers, 10 winches, radar, VHF, stereo, Volvo 18 hp w/new fresh water cooling, new mast, rod rigging, running rigging, halyards, new folding prop, topside teak, cushions, head, ice box and stove. (415) 652-2009 or (415) 929-0789.

32-FT WESTSAIL, \$42,500. Hull #417. Teak/mahogany interior: center table/fwd locker layout. 3 headsails, 1 stay sail, 1 drifter. Perkins 4-108. Needs new mainsail and boom. As is, where is. (650) 303-3901.

32-FT JEANNEAU ATTALIA, 1984. MDR. \$18,500. Racer/cruiser, all lines lead aft. Yanmar FWC, folding prop, hydraulic backstay, new batteries, new RWC pump, racing sails, new spinnaker, Tuff Luff. New anchor and rode. Tiller/pilot. Original Dacron sails. www.flickr.com/photos/windhorze/sets/72157626168401808/. Call (310) 592-5701.

33-FT RANGER, 1974. La Paz, BCS, MX. \$28,500. Ranger 33 refit to cruise. Bristol condition, turnkey, ready to sail. Possible owner finance with down. For full details and pictures call (303) 408-4696 or (720) 290-5604 or email svbrighid@gmail.com.



35-FT J/109, 2004. Coronado Cays. \$198,500. Winner, comfortable cruiser; best-equipped and maintained J/109 available in the West with every available option. Royal blue Ultrasuede interior, hot shower, dual GPS systems, Tack-ticks, removable radar, five sails, lazy jacks, Yanmar diesel. (858) 232-7500 or extixeno@aol.com.

35-FT NIAGARA, 1980. Sausalito. \$65,000. Canadian built cruiser by Hinterholler. South Pacific, Canada, Mexico vet. Radar, solar panels, wind generator, Spectra watermaker, diesel heater, Autohelm, serious ground tackle. Original layout, storage forward, walk through head and galley. (530) 913-2236 or svgambit@gmail.com.



34-FT CORONADO, 1970. Antioch. \$16,500. Easy singlehander: roller-furling jib, Dutchman mainsail. Autohelm, Garmin chartplotter, 2 VHF's. Hauled and painted 2010. New head and dodger, low hours on rebuilt A-4. Propane stove and cabin heater. (510) 676-4444.



32-FT RANGER, 1974. Alameda. \$14,500/obo. May 2011 New topside/bottom paint/batteries. Atomic Four. Many sails, hot water, internal halyards. Full race gear. Sleeps 5. Moving, must sell. Cash or trade. Contact for 2nd email: edhomer@hotmail.com. (813) 966-1334 or holorral@comcast.net.

35-FT PEARSON, 1969. Berkeley. Best offer over \$12,000. Bill Shaw, center-board, AP, GPS, DS. Roller furling, fridge, Yanmar diesel, 4 anchors. Call Ben. (510) 776-5836 or (510) 776-4592.



33-FT RANGER, 1976. Dana Point. \$14,000. Rebuilt Atomic 4, new mast, internal halyards, new standing rigging, Furlex, Autohelm, spinnaker gear, Martec folding prop. Many sails. Some electric, plumbing issues. 90-day Dana Point slip sublease possible. (949) 690-3058 or (949) 493-9552 or prwilliams1@cox.net.



COLUMBIA 34 MKII, 1973. SF Bay. \$42,000/land trades viable. \$10,000 off for cash/gold coins. 2+ decades at sea, meticulously outfitted. Yanmar diesel runs great. Roomy, 7' headroom. Great cruiser, great liveaboard. Pictures, details, contact at the website: <http://thepinkpanty.net>. Contact boat4sale@sappfire.net or (415) 692-1330.

36 TO 39 FEET

37-FT GULFSTAR, 1978. Berkeley Marina. \$20,000. Great boat to sail, roomy, comfortable, stable. Extensive rehab in 2002, new standing and running rigging, through hull fittings, roller furling, head, holding tank and more. 50hp Perkins. Needs bottom job. Contact Jim. (619) 244-2144 or jimhumphrey@cox.net.



CAL 36, 1965. Monterey. \$25,000. Fast classic. Veteran of many Mexico cruises. Fully restored. Everything but the hull is under 10 years old. Recent rig, engine, sails, electronics. Extra tankage. Optional full cruising gear available. Monterey slip rights. Request brochure. Email daaddle@gmail.com.

38-FT HUGHES, 1970. \$20,000/obo. S & S design, built in Canada 1970. Approximately 74 hrs. on near-new engine. Great Bay boat with slip available in Monterey or Moss Landing. (831) 915-4984.

37-FT RAFIKI, 1975. Brickyard Cove Marina. \$45,000/obo. In need of some TLC. Equipped with radar, depth sounder, refrigerator, Volvo diesel. New aluminum mast, standing rigging and Stay Lock fittings in 2000. Financial situation forces sale. Contact (415) 328-4273 or baysailor@sbcglobal.net.

CATALINA 36 MK II, 1995. Alameda, CA. \$81,000. Excellent condition, includes windlass, hot/cold pressurized water, inverter, VHF, electronics, low engine hours, 15hp Johnson motor and Zodiac inflatable. Contact (510) 523-4081 or roystark@aol.com.

TAYANA 37 MKII, 1987. Alameda. \$110,000. Excellent example of Bob Perry's classic blue water double ender. Great sails, recent rigging, upgraded electrics, modern instruments, comprehensively equipped. Ready to go cruising now. Currently in Alameda, California. www.andysignolyachting.com/drumad3. Contact andy@andysignolyachting.com or (408) 858-2639.



37-FT PACIFIC SEACRAFT. Crealock design, 1980. Moss Landing, CA. \$99,000. World class blue water performance cruiser. 6-foot plus headroom. This boat is cruise ready with GPS, radar, solar panel, wind generator, liferaft, cruising spinnaker, Raymarine wind instruments and more. Very well maintained. Recent haulout included LPU on spars, new standing rigging, bottom paint and thru-hulls. Also new external canvas and internal cushions throughout. Sailboat Hall of Fame inductee for outstanding design, comfort, performance and seaworthiness. (831) 588-8502 or kspirit90@yahoo.com.



36-FT HUNTER, 2004. South Beach, San Francisco. \$110,000. Dark blue hull which I believe is the only one on the Bay. Furling jib and main, dodger, nice interior, well maintained. She is a real beauty. (408) 375-4120 or stan.wilkison@yahoo.com.



Spaulding Wooden Boat Center
Youth Boatbuilding Program • Community Sails
Boatworks since 1956 • We Specialize in Wooden Boats
Become a Member! 501(c)(3)
www.spauldingcenter.org • (415) 332-3179



Afterguard Sailing Academy
The Affordable Way to ASA
ASA 101-Basics to Adv Ocean • Group & Private Instruction
Charters, Fun Sails, Youth Camps
(510) 535-1954 • www.afterguard.net



DOGGIEVENTURE – A doggie daycare on the go!
Morning or afternoon sessions available in San Francisco
In-home training and nail trimming (for cats, too!) in S.F. and outlying areas
www.doggieventure.com • (415) 314-7541



YOGA ON THE WATERFRONT IN SAN RAFAEL
Owner Julie Lucchesi is an avid sailor whose yoga classes uniquely address the needs of sailors.
\$15 drop in or 8 classes for \$88. www.bowyooga.com,
(510) 333-8846 or yogaforu2009@gmail.com.

ONLINE



OR OFFLINE



Latitude 38

will entertain and inform you.

ONLINE:

www.latitude38.com

OFFLINE:

at your favorite marine store.

39-FT FOLKES CUTTER, 1986. South San Francisco. \$38,000. Cutter-rigged steel bluewater cruiser/liveaboard. S. panels, refrig/freezer, radar, depth sounder, Yanmar 3-cyl., dinghy, SSB and VHF, mahogany/teak factory interior. Rewired and plumbing redone 6 years ago. (510) 290-8436 or joshuabewig@gmail.com.

37-FT CREALOCK CUTTER, 1980. Monterey. \$45,000. Ballenger tabernacled mast. New Yanmar w/saildrive, radar, GPS, easy access to all systems, 70gal diesel, 3 watertight bulkheads. Not in yacht condition, needs finish work. Great little sailing ship. Price firm. Email ddatpbio@gmail.com.

38-FT FARALLON CLIPPER #14. Tiburon. \$45,000. *Ouessant*. Built 1957, Stephens Bros. in Stockton. Excellent condition, well maintained. One owner since 1974. Many good sails, Volvo diesel engine. Full boat cover, loaded with equipment for Bay racing and cruising. Contact phbuck@sbcglobal.net or (415) 435-0936.



CAL CRUISING 36, 1971. San Pedro. \$25,000. Raised dinette, rebuilt diesel, Profurl, lazy jacks, hydraulic/tiller steering, Avon, windlass, SuperMax and Danforth anchors, Origo and electric stoves, pressure water, electric head, ample tankage, VHF, GPS, manuals, spare parts, more. Contact gercke@surfside.net or (909) 626-2858.

HANS CHRISTIAN 38T, 1977. Morro Bay, CA.. \$75,000. Beautiful black-hulled Hans Christian 38T, new engine/transmission, bottom paint 5-11, new dodger, solar panels, structurally sound, very "stock". (805) 595-7896 or (805) 544-5779 or tombaxterdc@yahoo.com.

40 TO 50 FEET



45-FT LOA RACER/CRUISER. Stockton Sailing Club. Now \$75,000/obo (was \$90,500). Laurie Davidson (Kiwi) Design with modifications by Carl Schumacher. This is a perfect liveaboard - roomy 3-cabin layout has "big boat winner" speed with furniture boat-Swan-like interior. Self tacker-jib roller furler with like-new fully battened North mainsail, cruise ready, with many extra sails. Shown by appointment only. Ray Lopez. (209) 772-9695.

41-FT MORGAN CLASSIC MODEL. 1991. San Carlos, Mexico. \$93,000. Cruiser, in primo condition, ready to go. Spacious interior - must see to appreciate. Recent survey. Use link for current photos, complete equipment list: <http://sailboatvagari.blogspot.com>. (520) 825-7551 or stanstreibig@gmail.com.



41-FT BARNETT CUSTOM SLOOP. \$149,500. 1986-2011. Around world vet. Singlehanded, glass composite, fast cruiser, 2 cabins, light and strong. Keel up refit. New: rod rigging, sails, rudder, engine, vac panel refrig, pilot, electrical, etc. For complete specs contact R. Humphrey or go to website <http://yachtsoffered.com> and search #1291703. Contact (510) 834-3261 or rhumphrey@sbcglobal.net.

44-FT BENETEAU OCEANIS 440, 1995. Sausalito berth. \$110,000, partnership considered. Excellent shape, cherry wood interior with 3 cabins, 3 heads. Garmin 10" HD color radar, weather. 11"3" inflatable 15hp, Autohelm ST7,000, Sea Frost. Contact Bob. (415) 713-9515 or bob.irby@marincounty.net.



43-FT MORGAN NELSON MAREK. 1985. Moss Landing. \$89,900. Total refit completed. New bottom and top hull paint. New rigging including Hi-Mod turnbuckles, new interior, ports, wiring. Engine room re-insulated, low hours on Perkins 108. New lifelines, plumbing, and Raymarine electronics. New radar and chart plotter. Autohelm refrigeration, windlass. Enclosed dodger. Two large berths, two large heads with shower. Comprehensive renovation. Well-respected cruising boat. Pictures at website. www.capitolareef.com. Contact Jay. (831) 464-0234 or (831) 464-0318 or capitolareef@yahoo.com.



40-FT JEANNEAU SO, 2000. Great Lakes. \$145,000. Two cabin, one head, roomy galley, huge lazarette. Located in one of the most beautiful sailing areas in the world (June to September) in the center of a thousand-mile arc across the northern Great Lakes. Countless intimate anchorages, islands, charming small town harbors, clear drinkable water. Currently in the North Channel of Lake Huron. A noncorrosive environment. Original zincs still look new. The boat has been in the water for only 20 months. Well cared for, lightly used, nicely equipped. We believe the space allocation and overall design of this boat to be better than any 40 footer and even the newer Jeanneau. Email Lynn to request an information package. (707) 823-3309 or lynnneed@sonic.net.



45-FT ALDEN COUNTESS KETCH. 1965. Fort Lauderdale, Florida. \$95,000. OPPORTUNITY! Circumnavigation cancelled due to seller's ill health. This classic sought-after, rugged Pearson-built yacht with full refit is available! Easily sailed, flush decks, all new windows and ports. From new engine, transmission, windlass, electronics and long list of cruising gear, this is a great deal. Please call broker for details and extensive equipment list. (954) 684-0424 or dosar@aol.com.

42-FT CASCADE, 1971. Alameda. \$39,000. Beautiful, good sailing boat. Mexico vet. Forward cabin sleeps up to five. Aft cabin sleeps two with separate head. Large, comfortable mid-cockpit, with hard dodger windshield. Jib, genny, cruising spinnaker. Radar, etc. Email deanmillican@comcast.net.



41-FT BENETEAU OCEANIS 411, 2001. Mediterranean. \$139,000. The perfect couple's cruising boat with offshore capabilities. Two-cabin owner's version. Designed by Groupe Finot and built by Beneteau in France. Well-equipped and meticulously maintained. Never chartered. Stored on the hard at least six months per year since new. Only 1,100 hours on Volvo 59hp engine. No sales tax, personal property tax, or value added tax for USA buyers. USCG Registered. Lying in the Med. Contact (415) 269-4901 or sail@voleauvent.com.



45-FT GARDEN YAWL. One off, double end, 3 years in restoration, 98% completed, cold-molded over original strip planked, new electric motor. \$60K as is, or \$? to finish. Contact (916) 847-9064 or stevebarber046@mac.com.

42-FT CATALINA, 1990. South Beach Harbor, San Francisco. \$99,500. Great condition. Extensive upgrades. Full spec at: <http://leluya.blogspot.com>. (650) 241-1440 or leluya123@gmail.com.



46-FT MORGAN 462, 1981. Vallejo Marina. \$160,000/obo. Bulletproof center-cockpit cruising ketch, keel-stepped masts, integral ballast, skeg-hung rudder, external chainplates, two cabins/heads, many new systems, immaculate. <http://s766.photobucket.com/albums/xx309/tmessenger/Morgan%20462%20Cruising%20Sailboat/?albumview=slideshow&tr>. (707) 334-3670 or baryb@aol.com.



40-FT O'DAY, 1986. Redwood City, CA. \$60,000. Great condition/great price. Very clean. New Yanmar and Wabasto heater. Liveaboard possibility for qualified owner. (650) 743-3422 or (650) 363-1390 or steve@spinnakersailing.com.

46-FT KELLY PETERSON, 1982. Morro Bay. \$189,000. Cruise ready with long list of equipment. 2 staterooms, 2 heads with new electric toilets, reefer and freezer, large center cockpit, etc. Comfortable and great sailing boat that's ready to go anywhere! www.facebook.com/pages/Kelly-Peterson-46-sailboat/172704439424234. (805) 459-1909 or woodeneye53@yahoo.com.



BENETEAU 473, 2004. Beautifully maintained, lavishly equipped, lightly used, three staterooms. Elite upgrades: electric winches, bow thruster, air conditioning, heating, generator, MaxProp, Yanmar engine, epoxy barrier, forward scanning sonar. Best 473 buy. Possible tax advantages! For complete info and photos visit: <http://yachtmicus.com>.



43-FT ROBERTS 434, 1997. Tomales Bay. \$65,000. Fantastic safe cruising boat ready for new family to cross oceans or explore Baja. Corten steel, 300hr Yanmar, 640w solar, watermaker, davits, windlass, good sails, Raymarine autopilot, plotter, radar. More at <http://sites.google.com/site/svfunkadelic/home>. Email svfunkadelic@gmail.com.



44-FT KELLY PETERSON. Cutter rigged sloop, 1977. South Coast/Turkey, Kemer Turkiz Marina. \$110,000. New: rigging, diesel tank, water tank, stove, water heater, thruhulls, dinghy engine, E120 radar, SSB radio, VHF radio, 300 ft galvanized chain. 1993 Perkins diesel rebuilt 2009, Maxwell windlass/washdown, 110/220 wiring, solar panels, KISS wind generator, PUR watermaker 5 sails including beautiful chute, 18tons, uncountable tools and spare parts. We have outaged her. (702) 767-8322 or (90) 535-088-0389 or jking38701@aol.com.

41-FT CT, 1970. Newport, tax free Oregon. \$59,900. Professionally maintained, fiberglass ketch, full keel. CT41 documented custom built, well founded, new bottom, rebuilt Perkins, non-skid deck, radar, depth finder, GPS, roller furling, Dickenson heater, new main. Contact (541) 234-6048 or (541) 294-3703 or kcdoni@netzero.net.



43-FT TASWELL, 1995. Bainbridge Island, WA. \$309,500. Pristine, center cockpit full enclosure, Leisure furl main, electric winch, RF genoa, low hours on main and 5kw genset, watermaker, chart plotter, radar, ESPAR heat, much more. <http://nxtues.wordpress.com>. (206) 295-1024 or ntuesday1995@hotmail.com.



44-FT TARTAN 4400, 2003. Channel Island Harbor. \$439,000, or trade?. Dark green hull, low hours, bow thruster, electric winches, VacuFlush heads, spinnaker, new batteries, recent bottom paint, numerous other options/upgrades. See test sail at YouTube.com, search Tartan 4400, our actual boat! www.youtube.com. (530) 318-0730 or amgjohn@sbcglobal.net.



41-FT NEWPORT, 1984. Bruno's Island Marina. \$55,000. Mexico vet, radar, GPS, autopilot, 40hp Universal diesel, solid rod rigging, 38 gal. fuel, 60 gal. water, sleeps 6, 8-ft dinghy with 9.9hp Nissan. Contact (707) 688-0814 or (707) 290-9535 or raaddink@yahoo.com. 1200 Brannan Island Rd.

51 FEET & OVER

53-FT BRUCE ROBERTS, 1996. Panama. \$375,000. *Jolka*, the aluminum sailing sloop is in very good condition. She was launched 2004, has only 500 hours on the big Yanmar 100hp. The survey made in 2008 assesses her replacement value for \$1.2M. She has everything. The detailed description and photos of equipment can be emailed on request. This vessel far exceeds the workmanship one expects in an aluminum boat. The interior joinery is superb and no expense was spared in the choice of equipment and materials. The workmanship and quality of this vessel is far above average and the accommodations below are sumptuous. This is absolutely a vessel for going to any corner of the world in comfort and safety. Email jolkaw@yahoo.com.



OFFSHORE PASSENGERMAKING INSTRUCTION IN THE SOUTH PACIFIC

John & Amanda Neal are dedicated to providing hands-on, documented instruction aboard their Hallberg-Rassy 46 *Mahina Tiare III*, drawing on their combined 544,000 miles and 69 years of experience. www.mahina.com • (360) 378-6131



PROFESSIONAL DELIVERY CAPTAINS

San Diego based, USCG Master 100 GT. Sail and power. ASA-certified instructional deliveries. Pacific Mexico and Baja Bash specialists. davidbrotherton@yahoo.com • www.boatdeliverycaptain.org • (619) 913-7834 •



TAILINGSYSTEMS, LLC

Tailing for all standard winches
www.tailinghook.com
salestailinghook@aol.com • (360) 427-9308

COMPLETE MARINE WOODWORK

Design / Restoration • Expert European Craftsmanship • Interior / Exterior Repairs / Maintenance • Marine Windows & Frame Replacement
Wood & Dry Rot Repairs • Varnish Work • Marine Painting
References Available • Reasonable Rates • Call (415) 331-6718

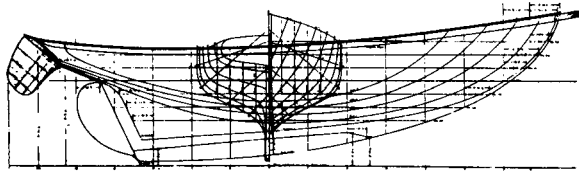

MAKELA BOATWORKS

Family owned since 1948

Wooden Boat Building • Repair and Restoration

19280 South Harbor Drive • Fort Bragg, CA 95437

(707) 964-3963

email: howard@makelaboatworks.com • www.Makelaboatworks.com



53-FT ISLANDER, 1979. Sausalito. \$129,000. Bruce King designed 53-ft cutter rigged, 4-cabin plus main saloon. Extensively equipped (Monitor wind vane, radar, heater, many custom improvements). Cosmetic refurbishment underway. Available for showing by owner after July 15. Contact (415) 250-4301 or jconnolly@ifpdialogue.org.



36-FT DANISH DOUBLE ENDER. 1926. Sausalito. \$35,000. Custom built in Nakskov Denmark in 1926, *Tehani* is a classic example of a Danish double ender. 36' on deck, 9.5' beam, 5.5 draft. Full iron keel. Cutter rigged. 4-yr-old 29hp Yanmar with low hours, new main, gennaker, and staysail. Rebuilt bronze Baby Blake head and refinished interior. 4-yr-old standing rigging. Full boat cover and bronze lifelines. Garmin chartplotter with integrated AIS receiver. Boat is ready to go. <http://picasaweb.google.com/pgaletani/Tehani?authkey=Gv1sRgCJ3btuK3k7LhEg&feat=directlink>. Contact (415) 246-7712 or pgaetani@gmail.com.



54-FT SAMPSON. Ferro Cement ketch, 1973. Emeryville. \$25,000/obo. MUST SELL. Work in progress. 13' beam, 85hp Perkins 4.236, 600 gals. diesel, 400 gals. fresh water, Raymarine GPS/sounder, 2000 lb. windlass, wind generator, hand carved teak. Contact (415) 238-2985 or joshuabartone@gmail.com.

MULTIHULLS

34-FT GEMINI 105MC, 2005. Redwood City, California. \$149,500. Great family or race boat. Perfect for San Francisco Bay, coast, Mexico, and beyond. Fast; easy to sail without heeling. Spacious deck and interior. Elegant and comfortable. See website details. <http://loonasea.gibbons.web.stanford.edu>. (650) 380-3343 or brian.j.gibbons@gmail.com.

CLASSIC BOATS



34-FT SUNSET SLOOP, 1967. Sausalito. \$24,500. Sunset Sloop, built 1967 Stone Boatyard Alameda. Beautiful classic, absolutely gorgeous in/ out. Turn key condition. Master Mariner winner 2004, 2006, 2007. Ready to race or cruise in style. Contact (415) 336-3367 or nizzaneoz@aol.com.



40-FT CREGER CATAMARAN, 1989. San Diego Area. \$32,000. Factory built wooden boat with fiberglass overlay. Strongly constructed. Will sail or motor safely anywhere. The cat comes with a lot of cruising gear. Some installation required, but not a ton. Also search Facebook name *Cat Flyingfree* for pictures and details if you are reading the printed magazine. www.facebook.com/media/set?set=a.103531009740381.5820.10002504461748&l=2d90d64faa. Contact (760) 630-4741 or (619) 208-0971 or mesozoid@yahoo.com.

35-FT ARTHUR ROBB LION, 1962. San Francisco Bay Area. \$45,000. Price reduction! Beautiful! Complete restoration in 2003-2005. Teak hull, copper riveted, bronze floors, new galley, head, sails, etc. Restoration too extensive to print here-complete documentation written and in photos. 2006 winner-Stone Cup. 2009 Master Mariners tee shirt boat. A great sailboat for racing, cruising or just day sailing. She is extremely well-maintained and ready for sailing! (707) 462-3507 or (707) 972-1376.

34-FT GEMINI 105M, 2000. Ventura Harbor. \$105,000. This is a very clean and well equipped catamaran that is ready for coastal cruising or longer passages. Blue water proven. Capable, comfortable, fast and fun. www.gemini105m-forsale.com. Contact (805) 217-3939 or dick.mahoney@gmail.com.

43-FT JOHN ALDEN #309N, 1930. Marina. \$85,000. Beautiful staysail schooner. Must sell, not living in Cali anymore. Recent hull, deck, wood spars upgrades. New rigging. 43hp diesel. Hull is cold-molded with Awlgrip paint. Documentation of all work, surveys available. Dry-dock. Email alden309n@gmail.com.

51-FT NEWICK TRIMARAN, 2003. Auckland. \$392,000. Newick's best, fast and beautiful, as usual, with unusually fine seagoing accommodations for five to seven. Superbly built, outfitted, and cared for by a meticulous, experienced owner. Photos, video, and specifications: www.trvlr.net.nz. Contact (707) 217-0581 or newnaut@gmail.com.



**1,000 Used Sails
Listed at
minneysyachtsurplus.com**

**We Buy Good Used Sails
and Marine Equipment**

MINNEY'S YACHT SURPLUS

1500 Newport Bl., Costa Mesa, CA

949-548-4192 • minneys@aol.com

"We keep boating affordable!"

WEDLOCK, RAMSAY & WHITING

Marine Surveyors

Vessel surveys,
consulting, deliveries.

Serving the
Bay Area
since 1980



www.norcalmarinesurveyors.com

(415) 505-3494

Ryan's Marine

*Specializing in Marine Electrical
Services for Your Boat*

- Electrical system installations from inverters to electronics packages
- Troubleshooting of existing systems
- Dealer for the complete Balmor product line
- Head and holding tank installations

Featuring
ESPAR
hydraulic heater
installations

MEMBER
ABYC
Setting Standards for Safer Boating

(510) 385-3842

Ryan Schofield
Owner since 1997

email:
rssailor@yahoo.com



34-FT GEMINI 105M, 2000. Pt. Richmond. \$114,000. Hull #660. World's most popular catamaran, comfortable cruise equipped with 3 headsails, traveler, davits, and more. 14' beam fits standard berths. Send email for list of equipment. Will consider trade down. More at <http://kirkstuff.com>. (510) 367-0500 or jadawallis@hotmail.com.



50-FT CATAMARAN, 2001. Whangarei, New Zealand. \$510,000. An exceptional 15.3 meters offshore cruising catamaran. Configured during construction as a comfortable and safe live aboard, capable of single handed passage making. Ron Given-designed, NZ built, launched in December 2001. Well known in Vanuatu, New Caledonia and New Zealand. Professionally maintained, fully refitted, in excellent condition. Lying Whangarei, NZ. More details at website, search listing #134528. www.theyachtmarket.com. (504) 201-3888 or amderne@yahoo.fr.

POWER & HOUSEBOATS

41-FT ROUGHWATER, 1982. Los Angeles. \$65,000. All fiberglass exterior, Perkins diesel, fast pilothouse trawler. All wood interior, typical RW41 in good condition. Anchor out for continuous sunny weeks, solar panels, on demand propane water heater without generator. Email jdtarle@hotmail.com.



36-FT HUNTER SEDAN CRUISER. 1964. San Rafael. \$7,500. Sedan Cruiser liveaboard in good shape, mechanically sound, needs head. Classic wooden boat model for savvy owner. Monthly slip cost \$675 (utilities included) at San Rafael Yacht Harbor, great marina location. (510) 409-9810 or richards.wilbur@gmail.com.



32-FT WINDSORCRAFT, 1992. Home-wood, CA. \$59,000. Price reduced \$30k - now \$59k - really want to sell! Style of wood, ease of fiberglass. Perfect for entertaining. 32' x 11'6", easily accommodates 8-10 guests. Glass hull, beautiful mahogany decks/interior. 2x Volvo big blocks, 350 +/- hours. GenSet, entertainment center, microwave, icemaker, refrigerator, electric grill, trash compactor, blender, VacuFlush head, central vac. Trailer and full cover included. (775) 848-5545 or em4bartz@aol.com.



31-FT ALBIN, 2000. Belvedere, CA. \$169,000. It's a Hummmddinger! Tournament Express. Beautifully equipped, maintained, and upgraded. Twin diesels, 500 hours, genset, heat/air. Comfortable, fast and stable with large cockpit. Perfect for fishing, weekending, viewing the America's Cup, or a club committee boat. 510-912-5800 for details. (707) 328-3775 or gvare71@gmail.com.

53-FT MATTHEWS, 1969. Richmond, CA. \$30,000/obo. Twin 871 Detroit, low hours, Webasto 80,000 BTU diesel heater, 3,000 watt inverter charger, excellent structural condition, Bay/Delta cruiser or liveaboard, excellent running condition, 21-knot cruise, 700 gal fuel capacity. Contact jodiannschrader@gmail.com or (808) 938-6105.



53-FT HATTERAS ED, 1984. Sausalito. \$219,000. I know, I'm a sailor too, but when it comes to waterfront habitat, you can't beat this 3bdm/3bath floating condo. Seaworthy, too! Think "outside the box", grab this great deal! More at <http://kirkstuff.com>. (510) 367-0500 or jadawallis@hotmail.com.

28-FT CARVER FLYBRIDGE, 1978. Sausalito. \$7,500. Spacious, comfortable floating home. Sleeps 4. Head with shower. Extensive storage. Remodeled. All work records available. Pictures available. Email floatinghome78@yahoo.com.

45-FT BAYLINER & SLIP, 1987. Pier 39. \$259,950. Think outside the box. 2 bedroom, 2 bath boat and slip at Pier 39 G Dock. Panoramic views of the Bay and City, front row seat for America's Cup from Sky Lounge. Contact (925) 628-9700 or envinnov@comcast.net.



34-FT CHB, 1976. Portland, Oregon. \$46,500. CHB, sleeps 7, full electronics, hot water, furnace, reefer/freezer, new genset, 2 heads with showers, aft cabin, dual steering, radar, 120 Lehman diesel, runs perfect at 1 1/2 gal/hour at 7 knots, 300 gal fuel, 200 gal water. Great vessel, always under cover. (503) 260-6872 or genelivingston@peoplepc.com.

35-FT CHRIS CRAFT CATALINA. sundeck, 1981. Sausalito berth. \$28,000/asking. Totally remodeled, clean, large salon and master w/large closet, separate shower in head. Great for home, floating office, cruiser. Good Chevy V-8's. Secure Sausalito berth, close to parking and tiled showers. May finance, lease option, or trade. (415) 999-5626.

43.5-FT LABELLE TRAWLER, 1983. Sausalito. \$125,000/obo. 360 view side tie adjacent to open space. Diesels w/500 hours, 7.5 Onan. Roomy glass-enclosed sundeck. Full canvas. X-large custom galley. Master has walkaround queen, tub + private guest stateroom with large bed, head. Outstanding workmanship/condition. May finance or trade. (415) 999-5626.

PARTNERSHIPS

CATALINA 42 MKII PARTNERSHIP. 3-cabin fully equipped for cruising, full electronics, SSB, watermaker, bimini, heater, liferaft, many more extras. Excellent condition and well maintained. Baja ready. 1/4 ownership for \$32,500 or offer. (925) 708-9547 or jljoe@gmail.com.

SAGA 409 PARTNERSHIP SFYC. Equity ownership in new Saga 409. Semi-custom Tony Castro design built by Westerly Marine. VacuFlush, flat screen TV, microwave, wine cellar. Electric halyard/mainsheet winch. Fast, easy to sail. Call or email for pics and specs. (415) 298-2080 or george@kiwi-properties.com.

BOAT SHARE FOR SALE. In established sailboat partnership: 1966 Ericson 35-ft sloop *Escape* is a well-maintained boat with a stable, safe design. She has classic lines and lots of exterior teak, with roller furling jib, lazy jacks and Atomic 4 engine. Excellently suited for day sails and over-nighters on the Bay, and nearby coastal waters. She is berthed in at the Richmond Yacht Club (RYC). New partner would have to join RYC per club rules. Interested parties contact Richard Seals (days & evenings) (510) 528-3123.

1/3 OR 1/2 SHARES. 44-FT Beneteau Oceanis 440. Sausalito. \$35,000. Excellent shape, cherry wood interior with 3 cabins, 3 heads. Garmin 10" HD color radar, weather. 11'3" inflatable 15hp, Autohelm ST7,000, Sea Frost. Contact Bob. (415) 713-9515 or bob.irby@marincounty.net.



CATALINA 30 SHARE. Sausalito. \$270/month. Docked in the best Marina in the Bay, w/parking just steps to boat, 5 minutes to Bay sailing. Many upgrades: wheel/diesel/newer performance mast/spars, furling, MaxProp, GPS, spinnaker, new cushions. Share \$270 month for 7 days max/month. Photo is sistership. Contact Leeloves2sail@hotmail.com or (415) 332-5442.

J-105 EQUITY PARTNERSHIP. Tiburon. Lightly used 2001 J-105 available for attractive equity partnership. Experienced J-Boat lovers only. Thanks. Email bronnerlehe@yahoo.com.



SOUTH OF THE BORDER

SAILING THE SEA OF CORTEZ. in La Paz, sailing with a MacGregor 26X or Herreshoff 28. More at www.sailing-baja.com. Contact (011-52) 612-123-5440 or info@hacienda-sol.com.

JUANCALITO PALAPA. Available for lease. Near Loreto. \$18,000. 100 feet from water, palapa with 23' trailer, carport, safe area, great landlord, potable water, fishing, diving, sailing, storage, great vacation getaway, lease renewable, great base for Sea of Cortez sailors! Airport/services - Puerto Escondido. For more info, email pandoless@yahoo.com.

MULTIHULL YACHT DESIGNER • MARINE SURVEYOR

John R. Marples, CMS • Certified, National Association of Marine Surveyors
Multihull Design Specialist • Pleasure and Commercial
Design office for Jim Brown Searunner, Seaclipper & Constant Camber Multihulls
www.searunner.com • (707) 343-1378 • marplesmarine@comcast.net

Sail, kayak, whale watch, or explore the majestic San Juan Islands!
Relax or take the helm aboard our 45' Jeanneau in the pristine Pacific Northwest.

Learn to sail from an experienced USCG captain.

4 guests max, 2 cabins - each with own head.

www.nwcharters.net



✪ **EXPERIENCED SAIL AND POWER SKIPPER** ✪
with over a dozen Cabo/La Paz returns and an additional 100k delivery miles
available for deliveries from any Mexican port north to the Mainland US.

Crew provided for bidding larger vessel deliveries if needed.

✪ rorykremer1@yahoo.com ✪



Get the Reliable, Powerful Wheel Pilot

Quiet & Dependable • Affordable • Built for Immersion
Easy Owner Installation • Low Power Consumption

831-687-0541

www.cptautopilot.com

BUSINESS FOR SALE



DIESEL FUEL FILTERING



Purify Diesel Fuel & Flush Tanks

Process scrubs, polishes, removes algae, dirt, sludge, rust, water, and foreign particles from diesel fuel. Includes internal tank washdown. Save your injectors, costly engine repair and down time.

Since 1989. Fully insured. Your berth or boat yard.

(510) 521-6797 Fax: (510) 521-3309

www.dieselfuelfilterings.com

Simply Great Sleep



Transform your mattress with our box-spring system and enjoy many relaxing nights aboard.

Froli

phone 888.463.7654
Nickle Atlantic, LLC
www.FroliSleepSystems.com



BLUE PELICAN MARINE
Nautical Consignments

*A Sailor's
Consignment
Chandlery*

NEW & USED BOAT GEAR
Open Tues.-Sat. 10 to 5 p.m.

510-769-4858
Located at Grand Marina
www.bluepelicanmarine.com

**Mobile Marine Navigation
Installations and Marine
Electrical Work
POWER
& SAIL**

**VESSEL
ELECTRIC**

GARMIN
certified installer

Raymarine
certified installer

Milltech Marine AIS **NAVPOD**

Brian Theobald • (415) 424-2204 • vesselelectric@yahoo.com



PLAN YOUR MEXICO GETAWAY NOW. at the brand-new, gorgeous Cielo Y Mar condos. Located in Punta Mita, 35 minutes from Puerto Vallarta, available to rent from private owner. On the beach, 10 feet from the water, they offer spectacular views of ocean and mountains, the biggest infinity pool in the area, an endless beach, great surf breaks, great fishing, tremendous views of whales, bird life and the islands. While uncrowded and tranquil, just a five-minute walk to several waterfront restaurants. Choose from a spacious, beautifully furnished one or three-bedroom unit, or an amazing two-story penthouse with lovely shade trellis on the top floor. See details at website: www.puntamitabeachfrontcondos.com. To reserve, call: Dona de Mallorca at (415) 599-5012.

WANTED

ANOTHER WONDERFUL FLOATING houseshare. I have had the delight of being on Issaquah Dock since March in a temporary houseshare that is coming to an end 8/1. Do you have a spare room available and would appreciate a respectful, mature and buoyant housemate? I have regular work in Mill Valley and enjoy a simple life. If you have or know of a situation close by, please give me a ring at (415) 272-3048. Thanks! Penny.

CATAMARAN HULLS CALIFORNIA. Fiberglass hulls only 20'-22' Tornado or equivalent. Contact (408) 529-9279 or bernardlc@sbcglobal.net.

GEAR

NEW 50-WATT POLYCRYSTALLINE. solar panels, \$250 each. Approximately 2' x 2'. Bought too many for a boat project and have some left over. Selling cheap to make them go away! 10-amp regulator, \$75. Call Rob in Sausalito at (503) 490-3305.

HENRI LLOYD OCEAN GORE-TEX. foul weather/Fujinon bino. Santa Cruz. Gear \$475/Bino \$750. Perfect gear for perfect storm! Red breathing, Gore-Tex Ocean Technology, Men's Large, ht. 6, chest 43-45, waist 38, inseam 33. Fujinon Techno-Stabi-14 x 40. Waterproof w/factory certificate. Image stabilized binoculars. (831) 325-6043.

ELECTRIC PROPULSION SYSTEMS. \$25,000. Two new, complete OSSA Powerlite systems. Each system includes 25kw generator, 27hp motor, touch-screen, throttle control, distribution box, wire, pumps and manuals. Original cost approx \$75,000 each. Will sacrifice for \$25,000 each or \$45,000 both (for catamaran). electricprop@gmail.com.

15' PARA TECH SEA ANCHOR. for boats to 40', \$450 (WM \$900), includes large swivel but no rode, like new, 9' Livingston dinghy \$400, Santa Cruz. (831) 295-3958 or multihuller@yahoo.com.

OUTBOUND 46 MAINSAIL, \$5,500. Carl Schumacher-designed Outbound 46 mainsail 7.7 Hood Vektron sailcloth, 52.00 X 18.50 X 54.00, 3 reefs, 6 full length battens, Antal 50 series batten hardware and Antal 50 series track slides, Sparcraft clear anodized boom and boom gooseneck with 3 internal reef sheaves at aft and forward boom ends, three reef lines, internal clew outhaul with purchase, Sparcraft rigid boom vang with purchase, vang lug on boom, boom preventer pad eyes on the boom, 53.00' Antal series 50 batten traveler track for back of the mast with Antal sail slide gate, EZ-JAX lazy jack system, standard mainsail cover and Hood Easi-Stow cradle mainsail cover. Contact Robin. (415) 332-4104.

MONITOR WIND VANE (OLDER). Santa Barbara. \$600. Older model (can't read serial number) Scanmar/Monitor wind vane that came with my boat. It worked, but I only sail locally and wanted a clear transom. Good to have if you're headed to the Baja Ha-Ha or offshore. Email mpbeach@mac.com.

PARATECH 18' PARANCHOR. And more. Paratech 18' Paranchor, wheel adaptor (Monitor). PUR: 06/35, Power Survivor 35 watermakers. Avon inflatable, new storm jibs. 20" R17, 12"-13"-14" RH props. Henry-Lloyd insulated XL suit, wet-dry suits, bangsticks, large round bronze portholes. Aluminum davits, 90W solar panel, headsails. (415) 497-3731 or brad-low@sbcglobal.net.

MISCELLANEOUS



PALADIN IS BACK-THANKS TO SO MANY. Thank you, Captain Fred Fegley & *Latitude 38*, for the heads up; KKMI for the opportunity; Kelly Hartgraves for enduring patience and Randy Sharpe for the report of your hammer! Thank you, Ged Delaney, of Kingman Yachts, for the 'voice of reason.' Big thanks to Lou, Jay & everyone at Whale Point Marine & Hardware; Tom & J at Blue Pelican; Mike at Sausalito West Marine; Mike & Kelly at Garhauer; The Folks at Bollin and Minneys; Steve at Harrison Marine; Rick at Harken. Thank you Captain Mark Munson; Johnson Hicks; Guy Stevens; 'Fortress' Pat; Nathan, 'The Cleat'; Bob T; Richard Finch; Jim & Mathew; Norm; Tim Sell, great photos and Kendall Blake, "stick with it young man, you're the future", Butler Rigging set things right aloft, thanks Jay, Howard, James & Mark, nice job. Special thanks to everyone at Berkeley Marine Center for your able help and direction and particularly Cree Partridge for leaving enough room to breathe in a tight ship. Peter Lawrence, thanks for staying in touch, hope to see you aboard. Smooth Sailing to all, Tucker & Tom Deming.

MARITIME DAY CELEBRATION. 300 Napa Street, Sausalito. Galilee Harbor 31st Anniversary, Saturday, August 6. Flea market, food, music, boat raffle. For info call Galilee Harbor or go to our website: www.galileeharbor.org. (415) 332-8554.

NAUTICAL FLEA MARKET. San Leandro Yacht Club, San Leandro Marina. \$25 per table. Saturday, July 16, 8am - 3pm. Nautical gear and more! Come early. Breakfast burritos. Lunch BBQ. Live music by the Back Water Boys. More info at <http://Sanleandroyc.org>. (510) 351-3102 or commodore1@sanleandroyc.org. 20 Mulford Point Drive.

TRAILERS

SAILBOAT TRAILER. Vacaville. \$2,900. Fits 25-ft to 27-ft sailboats. All points are adjustable, tandem axle with brakes. (707) 469-9163 or (925) 698-1100 or upde@comcast.net.

CLUBS & MEMBERSHIPS

SAN JOSE SAILING CLUB. For cruising, trailerable, and dinghy sailboats. Bay, Delta, lake, and ocean outings. Improve sailing skills; learn boating safety. Learn to maintain and upgrade your boat and equipment. Low dues. More information at www.sanjosessailingclub.com.

SINGLE SKIPPERS AND CREW of all abilities are invited to join the Single Sailors Association. Membership includes daysailing, raft-ups, invaluable onboard training, social events. Meetings held 2nd Thursday, Ballena Bay Yacht Club, more at www.bbyc.org. Social; 6:30 pm. Meeting; 7:30 pm. Guests welcome. www.singlesailors.org. (312) 402-3663.

PROPERTY SALE/RENT



GORGEOUS WATERFRONT HOME. w/30' boat dock. San Rafael. \$478,888. 2 BRs ensuite, 2.5ba, gated, end unit, approximately 1428 sq', F/P, decks off LR and DR, (new) washer/dryer. "An oasis of tranquility"! Furniture negotiable. Near 101 and 580. Call (415) 290-MONA (6662) or Mona@MonaMovesMarin.com.

BRICKYARD COVE PROPERTIES. Pt. Richmond. \$595,000 and up. Two lots, one home, available in Bay Area's "Sailor's Paradise". Enjoy America's Cup from your private deck! View each property on website or call. Private party, broker co-op welcome. <http://kirksstuff.com>. (510) 367-0500 or jadawallis@hotmail.com.

TRYING TO LOCATE

CAPTAIN GORDON KRUSIN of John Calley's 65-ft S&S Yawl *Barracuda II*, renamed *Olinka* - contact Jim Costalupes, regarding sea service time, at j.costalupes@sbcglobal.net or (775) 742-1004.

CAPTAIN BOB WILSON of 60-ft Gaff rigged schooner *Sea Runner* - contact Jim Costalupes, regarding sea service time, at j.costalupes@sbcglobal.net or (775) 742-1004.

BERTHS & SLIPS

SLIPS AVAILABLE. Aeolian Yacht Club, 20'/40' @ \$4.76 a foot. MUST be a club member. Join Aeolian now and bring in your boat. Initiation fee reduced to \$100 during our Membership Drive through September. Call (510) 456-5911 or (510) 769-9205.

SLIP FOR SALE AT PIER 39. 36 foot slip at dock C-34. \$8,000/obo. Contact (408) 335-3566 or (408) 483-6699 or cilaandcharlie@sbcglobal.net.

50-FT PRIME SLIP PIER 39, SF. \$50,000. F-Dock, Slip 11, east side. Protected from wind. Close to gangway, showers and marina office. Covered parking across street with special rates for owners. Contact (559) 355-6572 or sorch@tempest-edge.com.

CREW

EXPERIENCED CIRCUMNAVIGATOR. - schooner - seeks select crew for two challenging passage legs: Brazil to South Africa - October-December 2011; and South Africa to Australia - January-March 2012. Intermediate stops planned enroute, south Atlantic and Indian oceans. Must be healthy and fit with some experience, participate fully and share expenses. Call Mike Johnson (505) 466-6326 or email Claire at clairehorn@comcast.net.

JOB OPPORTUNITIES

YACHT BROKER. Vallarta Yachts is seeking an experienced yacht broker for our Mazatlan office. Good knowledge of sail and powerboat design, equipment and operation required. Experience boating in Mexico a plus. Send resume to: info@vallartayachts.net.

BUSINESS OPPORTUNITIES

MARINE CANVAS BUSINESS. for sale, Owner retires from the most successful marine canvas business in the Bay Area! 25 year reputation at a great waterfront location. Turn key operation with 90 days of training available to qualified buyers. Business offered at \$150K with a 6-week backlog of work orders and deposits in hand. Please send inquiries (principals only) to: pcanvas@sbcglobal.net.

LIVE THE DREAM MAUI, HAWAII. \$1,300,000. Highly successful sailing and snorkeling day charter business in beautiful Maui includes 2 USCG, 49 passenger, performance catamarans and all permits required. Well established, excellent reputation and following. Email sailingmaui@gmail.com.



Start Line Strategies Winning Legal Planning for Sport Programs

10 years America's Cup Experience
Sponsor & Venue Arrangements • Crew Contracts
Vessel Shipping Logistics • Charter Agreements

Ashley Tobin

(925) 324-3686 • amtobin@comcast.net

eMarine Systems

Solar PV /Wind Generators
High Output Alternators
Low Power Refrigeration
Inverters/Chargers/LED's

Located in the heart of Fort Lauderdale's Marina Mile District shipping worldwide.
Authorized Air X/Air Breeze/Whisper repair center

www.eMarineSystems.com
salesinfo@eMarineSystems.com
954-581-2505

MARINA DE LA PAZ FULL SERVICE MARINA
S.A. DE C.V.

Friendly, helpful, fully bilingual staff

All new hardwood docks • Wireless Internet
Dinghy landing with potable water
New protective piling & sheetpile breakwaters • And more!

TEL: 01152 612 122 1646
email: marinalapaz@prodigy.net.mx
www.marinadelapaz.com
Apdo. Postal 290, La Paz, 23000, Baja California Sur, Mexico

KISS-SSB

The Simple, Proven
Marine SSB
Ground Plane



- Easy to install
- Superior performance
- Fiberglass/wood boats
- Sail or power

See www.kiss-ssb.com for more info or to order.



'Electronic Latitude has lots of 'Unique Visitors'!

- 'Electronic Latitude can be found at www.latitude38.com
- Four or five great stories and photos every Monday/Wednesday/Friday
- Debuted in April, 2000

Subscribe today for FREE at:
www.latitude38.com

Jake ID *Personalized Webbing*

Lifetime warranty – your information will never come off. Black nylon with red lettering.

- Crew Gear Bag Zipper Pull ID.
- Floating Key Buoy ID. Will float 3 keys. Soft, durable, flexible, won't scratch equipment.
- Docklines personalized.
- Fender lines personalized. 3/8" dia., spliced one end, braided line, 15-ft length, white.

(530) 885-8017

www.JakeID.com

Marine Diesel Specialists

AT YOUR SLIP!



30 years experience • Universal/Westerbeke dealers
Repairs/Tune-ups all models • Engine Surveys, Instruction

BAY MARINE DIESEL

510-435-8870

baymarinediesel@comcast.net

THE RAMP

BAR OPEN EVERY DAY & EVENING

WEEKENDS

Brunch Served 9:30 am-5:00 pm

LIVE MUSIC

Saturdays ~ Salsa

Sundays ~ International sounds
with Outdoor BBQ 5:30-8:30 pm

WEEKDAYS

Lunch Served 11:00 am-3:30 pm

Happy Hour M-Th 5:00 pm-7:00 pm

855 Terry François St., San Francisco

www.theramprestaurant.com

(415) 621-2378

MORE ENERGY!

KEEP BATTERIES CHARGED!

- KISS wind generators
- Solar panels and MORE

USE BATTERIES EFFICIENTLY!

- LED lights
- Engel fridge/freezers
- Wonder Wash and more



www.svhotwire.com

727.943.0424

JUST YOU AND THE SEA...



...and the jacuzzi,
the 80-ft long pool, the surf,
the Punta Mita anchorage, and the 4-mile distant
Tres Marietas Islands

Punta Mita Beachfront Condos

Call Doña de Mallorca for reservations!

1.415.599.5012

www.puntamitabeachfrontcondos.com

ADVERTISERS' INDEX

AB Marine..... 54	Boat US..... 67	Diesel Fuel Filtering 162	Hansen Rigging 49	Lee Sails 150
Adventure Cat Charters 133	Boat Yard at Grand Marina, The..... 21	Dockwise Yacht Transport.... 62	Helms Yacht & Ship Brokers 167	Leukemia Cup 69
Almar Marinas..... 47	Bottom Siders..... 151	Downwind Marine..... 62	Hermit's Marine Service.... 148	Lewmar Marine..... 26
Antares Yachts 60	Brisbane Marina 90	Doyle Sails 25	Heritage Marine Insurance 110	Lifeline Batteries 57
Aqua Marine 53	BVI Yacht Charters..... 134	e Marine Systems 163	Heritage Yacht Sales..... 169	List Marine Enterprises 49
AVI Nautica..... 132	California Yacht Sales..... 167	Easom Rigging..... 57	Hogin Sails..... 28	Loch Lomond Marina..... 111
Bacon Sails & Marine Supplies..... 59	City Yachts..... 11	Emery Cove Yacht Harbor 53	Hood Sails..... 31	Lowrie Yacht Harbor..... 71
Bainbridge..... 33	Clipper Yacht Harbor.... 86, 87	Emeryville Marina 96	Hotwire Enterprises..... 164	Mack Sails..... 53
Baja Ha-Ha Sponsors 135, 136, 137	Club Nautique 22	Equipment Parts Sales..... 153	Hydrovane..... 151	Makela Boatworks..... 160
Bay Island Yachts 6	Coast Marine..... 58	Essex Credit Corp..... 38	Interlux Yacht Finishes..... 41	Manta Cat 166
Bay Marine Boatworks..... 45	Cover Craft..... 110	Farallone Yacht Sales..... 8, 9	Interphase Technologies 64	Marin Convention & Visitors Bureau 70
Bay Marine Diesel 164	Coyote Point Marina..... 63	Flying Cloud Yachts 167	Jake ID..... 164	Marina Bay Yacht Harbor 43
Bay View Boat Club..... 129	Cruise RO Water..... 101	Forespar..... 104	JK3 Nautical Enterprises 37	Marina de La Paz..... 163
Berkeley Marina..... 39	Cruising Yachts 7	Fortman Marina 71	KISS-SSB/Radioteck 163	Marina El Cid 151
Berkeley Marine Center 29	CYOA Yacht Charters..... 133	Garhauer Marine..... 17	Kissinger Canvas..... 67	Marina Puesta Del Sol 69
Beta Marine Engines..... 61	Davis Instruments..... 119	Gentry's Kona Marina 148	KKMI - Brokerage..... 169	Marina Riviera Nayarit..... 50
Blue Eagle Products 55	Delta Marina 129	Gianola Canvas Products.... 65	KKMI - Full Service Boatyard..... 172	Marina Village..... 30
Blue Pelican 162	Dept. of Boating & Waterways 27	Golden State Diesel Marine 150	Landing School, The 119	Marine Engine Co. 153
Blue Water Yacht Insurance ..42	DeWitt Studio 152	Grand Marina 2		Marine Outboard Co..... 24

Rooster

SAILS
 A REPAIR LOFT
 FAST TURNAROUND • CRUISERS, REPAIRS

In Memorium
 RUI LUIS
 1963-2011
*Rui will be missed,
 especially his wit and
 'larger than life'
 presence*

GREAT VALUES

WORLD CRUISER

 46' LIBERTY 458, '84 Asking \$179,000

COMFORTABLE LIVEBOARD

 36' FREEDOM, '86 \$65,000

CLASSIC

 32' DOWNEAST, '77 \$43,000

SAN DIEGO YACHTS
 Dreams for Sale
 (619) 370-8000
 www.sandiegoyachts.org

weatherguy.com

**Worldwide Marine Forecasts
 Cruising, Racing & Commercial**
 Packages Starting at \$65.00 USD

(866) 882-WXGY (9949) toll free
 (808) 291-WXGY (Mobile)
 (808) 254-2525 (Office)
 (808) 443-0889 (Fax)

 970 N Kalaheo Ave
 Suite C-104
 Kailua, Hawaii 96734
 info@weatherguy.com

www.weatherguy.com

1997 55' Custom-Built Cat

A world-class, U.S.-built and documented, charter/cruising cat built of FRP, with twin 50 hp Yanmars, GPS, autopilot, radar, VHF, SSB, and two steering stations. Sleeps 10, full galley, heads and showers, great ventilation, and extremely comfortable. Has flotation equipment for up to 50 people.

\$260,000 U.S.

*For more pictures and info go to:
 www.bluewaterhawaii.net
 or contact Dave at (808) 443-6282
 or bluewaterhawaii@gmail.com*



ADVERTISERS' INDEX – cont'd

Mariner's General Insurance..... 61	North Sails 34, 35	Rooster Sails 166	Spectra Watermakers 150	Vessel Electric..... 162
Maritime Institute..... 68	Opequimar Marine Center.. 59	Ryan's Marine..... 160	Sta-Lok Terminals 57	W.D. Schock Corp. 59
Marotta Yachts 170	Outboard Motor Shop 63	Sail California..... 14, 15	Start Line Strategies 163	Weatherguy.com 166
Mathiesen Marine 148	Owl Harbor Marina 55	Sail Warehouse, The 148	Stem to Stern 71	Wedlock, Ramsay & Whiting Marine Surveyors..... 160
Mazatlan Marine Center/ La Paz Yachts 10	Oyster Cove Marina 100	Sailrite Kits 44	Sterling Associates 153	West Marine..... 16.18.20
McDermott Costa Insurance.....65	Oyster Point Marina 58	Sal's Inflatable Services..... 105	Stright-Mackay 129	West Marine - Rigging..... 46
McGinnis Insurance..... 51	Pacific Crest Canvas 49	San Diego Yachts 166	Svendsen's Boat Works 23	Westpoint Harbor..... 56
Michael Wiest Yacht Sales .. 168	Pacific Rigging 101	San Francisco Boat Works 118	Svendsen's Marine 32	Westwind Precision Details.. 97
Milltech Marine Inc..... 40	Pacific Yacht Imports..... 13	San Juan Sailing 134	Swedish Marine 61	Whale Point Marine Supply..... 12
Minney's Yacht Surplus 160	Passage Yachts..... 5	Scandia Marine 60	The Multihull Company 168	White, Chris Designs..... 150
Modern Sailing School & Club..... 65	Pier 32 Marina 101	Scanmar International 55	The Ramp 164	Yachtfinders/Windseekers .. 10
Napa Valley Marina..... 36	Pineapple Sails 3	Schaefer Marine 63	TMM Yacht Charters 132	
New Era Yachts..... 168	Pittsburg Marina 153	Schoonmaker Point Marina 48	Tohatsu Outboard 51	
Nickle Atlantic 162	Punta Mita Beachfront Condos..... 165	Seacoast Marine Finance... 64	Trident Funding 4	
Norpac Yachts 171	Quantum Pacific..... 19	Seashine..... 68	Twin Rivers Marine Insurance..... 69	
North Beach Marine Canvas..... 97	Quickline..... 66	Seatech 153	Ullman Sails..... 70	
North Direct Sails..... 67	Raiatea Carenage Services..... 149	South Beach Harbor 52	US Sailing 105	
	Richardson Bay Marina 66	South Beach Riggers..... 97	Vallejo Marina 51	
	Richmond Yacht Club..... 91	South Beach Yacht Club 119	Ventura Harbor Boatyard..... 105	

**Don't forget to tell 'em...
 Latitude sent you!**





Flying Cloud Yachts



**Johns
Christian**

6400 Marina Drive
Long Beach, CA 90803

Sail • BROKERS • Power

www.yachtworld.com/fcyachts
flyingcloud@verizon.net

Phone (562) 594-9716
Fax (562) 594-0710



J/30, 1980 \$34,500



43' TASWELL, 1989 \$229,000



30' FISHERS Two: \$58,000 & \$29,000



35' COLUMBIA 10.7 \$49,900



57' BOWMAN, '78 \$164,500



25' LANCER powersailer w/trailer \$7,900



CF37, Transpac vet \$34,900



34' PACIFIC SEACRAFT, '88 \$104,000



41' FORMOSA CLIPPER, '80 \$89,000



44' HARDIN, offers



GEMINI CATAMARANS 4 available



42' KIWI, '85 \$34,000

APPROX. 100 LISTINGS ON OUR WEB SITE: www.flyingcloudyachts.com



49' Custom CC Motorsailer, '04
Global cruiser, CG-certified.
Ready to go. \$349,000



49' Dufour Prestige, '95
Great performance under sail
and at anchor. \$139,500



48' Tayana
Extensively tested bluewater cruiser.
Outstanding value! \$300,000



46' Hunter, '00
Huge layout and powerful sailing
style. All for \$195,000



41' Beneteau, '99
Stylish and functional for sailing,
cruising, entertaining. Just \$139,900



38' Baltic, '84
Created with quality Finnish craftsmanship.
Built for the sea. \$94,500

M U L T I H U L L S



CORSAIR 31R Extremely clean, with all the right stuff.
New boat coming: "Bring all offers." **\$113,000**



32' PDQ ALTAIR



NEW CORSAIR 750 DASH

CALIFORNIA
YACHT SALES

(619) 295-9669 • www.californiayachtsales.com



Helms
YACHT SALES INC.

www.helmsyacht.com • (510) 865-2511

Dealer for
Seawind Catamarans
Corsair Trimarans and
Dragonfly Trimarans



THE MULTIHULL COMPANY

THE WORLD'S LEADER IN MULTIHULL SALES AND SERVICE

www.multihullcompany.com

Let the world's largest international catamaran and trimaran brokerage, The Multihull Company, assist you with the purchase or sale of a multihull anywhere in the world.

The Multihull Company offers several distinct differences, from its pioneering buyer/broker program developed by founder Phillip Berman, himself a World Champion catamaran racer and author, to its international print advertisements that reach just the right buyers and sellers of catamarans, to its monthly newsletters that actually help readers understand the market, the latest trends in sailing, and even tackle the recent controversies about electric engines, helm station placement, daggerboards versus keels, etc., to our powerful online presence and social media know-how and U.S. and European boat show participation.

Visit us at www.multihullcompany.com and see why The Multihull Company is truly the choice for sailors around the world. We offer even the casual browser the means to understand the market with expert videos, articles and an extensive selection of catamarans and trimarans listed for sale.

FEATURED WEST COAST LISTINGS



43' CANTANA, 1999
San Francisco, CA
\$399,000



36' PDQ, 1994
Vashon Island, WA
\$149,000



40' FUSION, 2010
Vancouver, BC
\$550,000



50' MORELLI & MELVIN
Alameda, CA
\$999,000



53' CATANA, 1994
Newport Beach, CA
\$499,000



35' FONTAINE PAJOT TOBAGO
1994 Bainbridge Island, WA
\$149,950

SAN FRANCISCO SEATTLE FT. LAUDERDALE CHARLESTON FRANCE TURKEY TRINIDAD TORTOLA ST. MARTIN
Ph: 215-508-2704 Fax: 215-508-2706 email: info@multihullcompany.com



55' HALLMAN, '82
Fast, strong. Custom high grade construction. \$199,000



46' MORGAN, '81
Like new condition! Wonderful cruiser. Now only \$157,000.



44' NAUTICAT, '83
Well-maintained cutter rigged ketch. \$179,000



43' MAPLE LEAF, '84
Wonderful liveaboard restoration. Fabulous value. \$79,000



42' CATALINA MKII, '03
Three staterooms, rigged and ready to sail. Just \$195,900



36' ISLANDER, '76
West Coast classic. Clean, dodger, furler, more. Just \$36,995



2021 Alaska Packer Pl., Grand Marina, Alameda, CA 94501
sales@newerayachts.com • boatman@sbcglobal.net
(510) 523-5988 • www.newerayachts.com

Michael Wiest Yacht Sales

QUALITY PRE-OWNED SAILBOATS



44 BENETEAU, '95..... \$175,000



44' TARTAN, '75..... \$69,000



44' HUNTER DS, '05 \$199,000



42' HUNTER PASSAGE, '95..... \$110,000



41' BENETEAU, '99..... \$119,000



34' CATALINA, '86 \$35,000

CHECK THEM OUT AT
www.mwiest.com
then call (510) 601-5010 • Emeryville, CA



Maritime Yacht Brokerage

(510) 236-6633

fax: (510) 231-2355

530 West Cutting Blvd.

www.kkmi.com

yachtsales@kkmi.com

Pt. Richmond, CA 94804



HYLAS 46 (2002)

Powerful, go-fast cruising yacht for sailors with ambitious plans for comfortable offshore sailing. Set up for short-handed sailing, fully equipped with essentially every option. Meticulously maintained. **\$429,000**



BALTIC 42 DP (1984)

Since 1973, Baltic Yachts of Finland have been building comfortable, safe, long distance cruisers with very good sailing and performance characteristics. Doug Peterson design, superbly maintained, hull #29. Asking **\$149,000**



NELSON MAREK CUSTOM A 92-ft aluminum world cruiser. Recently repowered. Immaculate throughout and in perfect condition. **\$1,500,000**



FRERS 50' CUTTER (1947) German Frers, Sr., founder of the Frers yacht design dynasty, designed and built this classic wooden cutter for his own personal use. Without regard to cost, she's been restored and refit to better than new condition and shows true to her sailing heritage. Asking **\$295,000**



HINKLEY BERMUDA 40 MkII Yawl CB (1968)

Bill Tripp design is highly regarded for classic beauty, superb workmanship and quality details. New sails, dodger, intelligently updated. Excellent condition. Asking **\$147,000**



MUMM/FARR-OVINGTON 30 (1997) Solid and ready to sail at the highest level offshore or compete in the upcoming World Championships on SF Bay. Clean, well built, with many upgrades. Join the class today! **\$85,000**



SWAN 391 (1984) A beautiful flag blue Ron Holland design which is very well equipped and has had teak decks, engine and standing rigging replaced, and new sails that have never been used. Many extras. Asking **\$154,000**

HERITAGE

Yacht Sales

Live your Dreams



www.heritageyachts.com

Long Beach-Naples

Newport Beach

San Diego

Wilmington

866-569-2248

877-389-2248

760-402-3868

877-599-2248

Cell 310-995-9989



NEWPORT

62' Nautical Ketch, 1985
\$289,000



LA HARBOR

50' Santa Cruz, 1986
\$159,000



LONG BEACH

44' Morgan 440, 2005
\$261,900



LONG BEACH

40' Hunter 40.5, 1993
\$99,500



NEWPORT

33' Hans Christian Cutter
1988 **\$135,000**



NEWPORT

32' Catalina, 2005
\$105,000



Marotta Yachts of Sausalito

Brokers of Fine Sail and Motor Yachts

415-331-6200 • info@marottayachts.com • www.marottayachts.com

See at: www.marottayachts.com

NEW LISTING



61' C&C, 1971 Full specs up soon. Beautifully laid out; reportedly more than \$250k spent on her over the past 10 years. **\$299,000**

See at: www.marottayachts.com



53' HATTERAS, 1983 Over \$150k spent on improvements. Stabilized motor yacht in perfect shape, well equipped. **\$279,000**

See at: www.marottayachts.com



55' TAYANA CC CUTTER, 1988 Sturdy, well equipped vessel, outfitted by knowledgeable owners for world cruising. **\$249,000**

See at: www.marottayachts.com



41' SCEPTRE, 1993 Raised cabintop performance cruiser. Professionally maintained, only three owners. Bristol. **\$215,000**

See at: www.marottayachts.com



41' SCEPTRE RAISED CABINTOP CUTTER, 1985 Professionally maintained, updated electronics, more. **\$185,000**

See at: www.marottayachts.com



48' ISLANDER SLOOP, 1985 Pacem has had two long-term owners since new; shows beautifully today. New sails. **\$179,000**

See at: www.marottayachts.com

NEW LISTING



C&C 41, 1987 Very clean example of one of the best racer/cruiser designs ever built. Promises speed and control. **\$109,900**

See at: www.marottayachts.com

NEW LISTING



43' BENEteau 430, 1992 Three stateroom, very clean, never cruised or chartered. Transferable slip. Turn key package. **\$89,000**

See at: www.marottayachts.com

NEW LISTING

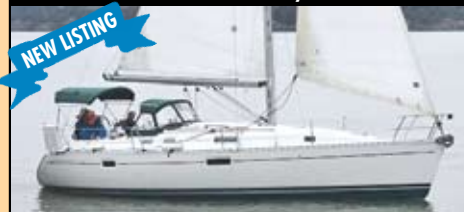

35' BENEteau OCEANIS 352, 1999 SUPER clean, less than 300 hrs on Yanmar dsl. Never chartered, cruised or raced. **\$85,000**

See at: www.marottayachts.com



30' BABA, 1982 Maintains crew for extended passages without sacrificing qualities of a great singlehander or weekender. **\$59,000**

See at: www.marottayachts.com

NEW LISTING



35' RAFIKI, 1978 As solidly built as the 37 and with cutaway forefoot so more nimble; considerably less expensive. **\$49,000**

See at: www.marottayachts.com

NEW LISTING



32' SABRE SLOOP, 1985 Rare on West Coast. A very nice Sabre example. Major refit '09 and shows nicely today. **\$44,500**

See at: www.marottayachts.com

NEW LISTING



35' MULL COLD-MOLDED SLOOP, 1972 Beautiful design. Freshly Awlgripp'd hull. Transferable Sausalito YH slip. **\$39,000**

See at: www.marottayachts.com



27' ERICSON, 1979 \$30k spent since '01. Less than 200 hrs on new 17 hp Yanmar 2GM20 dsl, new fuel tank, more. **\$17,900**

See at: www.marottayachts.com



26' CHEOY LEE FRISCO FLYER, 1968 Built as a show boat for a distributor in Seattle; one of the nicest we've seen. **\$13,900**

at 100 BAY STREET • SAUSALITO • CALIFORNIA 94965 since 1946

NORPAC YACHTS

1150 Brickyard Cove Rd., B9, Pt. Richmond, CA 94801
(510) 232-7200 • FAX (510) 232-7202
email: info@norpacyachts.com

THIS IS A GOOD TIME TO SELL!
We're Ready To SELL YOUR BOAT NOW: Just Call!

FOR MORE
SEE OUR
norpacyachts.com
WEBSITE



OLSON 30
A great racer/cruiser in nice shape, with lots of goodies and a galvanized trailer. See our website at www.norpacyachts.com for vast equipment list and many more photos. Now asking **\$13,950**



48' DUTCH CANAL BOAT by deVries Lentsch. Steel. Unique, comfortable cruiser for Bay/Delta. Diesel, tub, galley, fireplace, salon, convertible aft enclosure, beautiful decor, MORE! LIVEBOARD. A GEM! Now asking **\$209,950**



33' LAKE UNION DREAMBOAT CLASSIC by Blanchard. New Yanmar diesel, fresh finish, new bottom, largely restored. Covered Alameda berth and MORE! Great, solid classic cruiser. Asking **\$23,950**



46' ISLAND TRADER MOTORSAILER KETCH. F/G, dsl, in/out wheel steering, queen aft + double & single staterooms, 2 encl. heads w/showers+hub, AIS transponder, radar, AP, roomy, more! **\$89,950**



54' HERRESHOFF CENTER COCKPIT KETCH. Aft stateroom, 115hp 6-cyl dsl, full galley, AP, radar, GPS, dinghy+o/b, more! A big, comfortable, strongly-built, F/G, bluewater world cruiser from a fine designer, Faith comes with a lot of gear. Asking **\$199,500**



Established and unique SF Bay charter business featuring exotic dancers (girls and/or guys for ladies and/or gentlemen), liquor service, comfortable and spacious charter yacht w/tasteful traditional styling/decor. COI for 49 passengers. Turnkey operation. Possible seller financing. **\$295,000/offers**



36' ISLANDER Slp. Well respected and outstandingly popular Alan Gurney design. Wheel steering, dsl, full dbl linefiles w/pulpits, modified fin w/skeg-hung rudder, self-tailers, rigged for short-handed sailing, furling, well laid out and comfortable down below. New trans, dodger and MORE! Asking **\$34,950**



40' X-YACHTS X-119 HIGH-PERFORMANCE sloop. Renowned Danish performance cruiser/racer. Loaded with gear & high tech sails. Proven bluewater cruiser & race winner. **\$109,000**



36' STEEL KETCH by Hartog. Great builder/great designer! Strong 1985 bluewater cruiser loaded with diesel, radar, genset, watermaker, air/heat, RIB & O/B, O/S raft, windvane, wheel & LOTS MORE! Go anywhere cruiser. Needs some exterior maintenance updating. SUPER BOAT! Try **\$24,950**

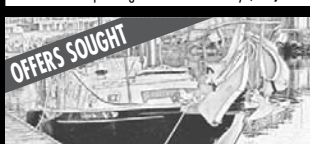

32' NANTUCKET CLIPPER MKIII. Yawl, dsl, exct. British craftsmanship, heavy F/G, wheel, good sails incl. spinn., GPS, depth, VHF, range+oven, frig, more! A seaworthy craft of high quality. A bargain at **\$14,950/offers**

Visit us at BEAUTIFUL & FRIENDLY Brickyard Cove Marina

SAIL

100' MEGA SLOOP Custom Offshore Performance Cruiser. Comfort & luxury, spacious, sleeps 17, loaded and near new. GREAT CHARTER POTENTIAL!!!..... Try 885,000

58' ALDEN Boothbay Ketch. Center PH cockpit, aft S/R, dsl, heavy glass, world cruiser. AWESOME!..... Asking 268,950

41' CF-41. Exquisite example of this revered Garden design with many custom features. Fiberglass, big diesel, teak deck, cabin heat & fireplace, tiled shower & head, gorgeous interior, alum. spars, full galley, refrigeration and much MORE! MUST SEE. Asking \$78,950

33+ ROYAL HUISMAN ALUMINUM Cutter by Alan Gurney; World class builder and designer. Yanmar diesel, new standing rig, nav station, liferaft & MORE! Family emergency forces 50% PRICE SLASH. Must sell NOW! This is way too cheap for this vessel!..... Asking 19,250

32' TAHITI KETCH, diesel, teak, partially restored and a BARGAIN..... Try 7,500

30' GARY MULLSloop THE SHADOW, by Eason Boat Works. Famous SF Bay racer completely rebuilt in near new or better condition. Diesel, excellent cold-molded construction. Ready to cruise/race and WIN!..... Asking \$74,950

30' RAWSON Cutter. Low hours diesel. Diesel range, much recent upgrading. Berth in Seattle's FRESH WATER Lake Washington w/sea access. New batteries, some new equipment still in box. Light/med Springtime cosmetics due. Unusually robust fiberglass construction. A solid & reliable Pacific Northwest cruiser with decades of fun & adventure ahead of her..... 19,950/Offers encouraged

130' CAMCRAFT Passenger Ship. Certified for 33 passengers overnight. Booked for the season. Virtual turnkey. Money and opportunity, working PNW..... 2,200,000

101' STEEL TUG with beautiful SAUSALITO BERTH. Great YTB, operational, fantastic opportunity. Loads of potential. Fabulous value!..... \$44,950/obo

100' Steel HIGH ENDURANCE ADVENTURE/CHARTER SHIP in Northern Caribbean. Turn-key operation. A great opportunity! MOTIVATED!..... REDUCED! 1,374,950

85' CLASSIC TUG, '23 Vancouver Shipyard. Recent CAT V-12 repower. Massive, beautiful and seaworthy. Perfect for Classic Tug Yacht..... 124,950/offers

62' ELCO 1926 CLASSIC MOTORYACHT. Twin dsl, gorgeous, elegant, comfortable. GREAT LIVEBOARD CRUISER. Must see! REDUCED! Offers encouraged!... 124,950

56' HOLIDAY MANSION Cruising Catamaran HOUSEBOAT. High-end custom interior, twins and MORE! Motivated seller has reduced her to..... 42,950/offers

56' LCM-6 STEEL Dive/Commercial Boat Conversion. Twin 671 diesels, alum. pilothouse & decks, & LOTS MORE!..... 29,950/offers

45' STEPHENS 1929 classic. Beautiful Gatsby-era motoryacht waiting to transport you back to the days of yachting in the grand style..... Try 75,000

43' MATTHEWS, '65, diesel. A gem! Loaded and beautiful..... Asking 69,450

42' GRAND BANKS Tvl. Aft cabin, F/B, Onan, twin dsls, radar. Excellent. Reduced!... 79,500

36' SEA RAY 360 aft cabin fly bridge express. Twins. Nice & a GREAT VALUE. Asking 34,950

34' CLASSIC LAKE UNION DREAMBOAT. We have TWO; a Blanchard and a Rathfon. Starting at a BARGAIN..... 17,500 Asking

33' CHRIS CRAFT Cavalier. Fresh twin GMC Marine 350s and MORE! This is a good buy on a good boat..... Asking 9,950

28' BAYLINER 2850 FLYBRIDGE SEDAN. New VOLVO/GM 300hp V8, economical & 30-MPH reported. Just completely refurbished & refitted to exceptional condition..... Asking 19,950

27' FARALLON Pilothouse, '86. F/G, twin 5L V8s, fast and seaworthy. Just detailed and very nice. Asking 51,950

22' ALUMINUM PLEASURE TUG. Bufflehead live/cruise. Loaded..... Asking 108,250



88' LUXURY MOTORSAILER Turkish Gulet Ketch. 7 staterooms with heads, showers, air & heat, plus crew's quarters. New CAT diesel, auxiliary genset. Large aft deck with canopy and side curtains. Recent FULL REFIT. Big 22' beam and MORE! \$1.2mil survey. Now Asking **\$349,900**



44' STEEL Canoe-stern cutter by Geo. Buhler/Fred Lagier & Sons. John Deere diesel. Stout steel construction. Awesome bluewater cruiser built to go to sea and stay there. Radar, GPS, etc. Here's your world beater! Asking **\$89,995**



57' BOWMAN Ketch. An AWESOME vessel completely equipped for world cruising. TOO MUCH TO LIST; must be seen. Has circumnavigated and also completed the Northwest Passage east to west. Seaworthy, comfortable and roomy, this is your ultimate bluewater cruising yacht. Asking **\$219,950**



49' CUSTOM Cold-Molded Ketch by Reliant. Beautiful Hankerson design. Powerful and seaworthy bluewater cruiser in great shape. Built '91. Yanmar diesel, furling, self-tailers, aux. genset, full galley, full electronics and MORE! MUST BE SEEN. Asking **\$119,950**

CALL (510) 232-7200 OR FREE (877) 444-5087
OR CALL GLENN DIRECT AT (415) 637-1181
FOR INFORMATION AND APPOINTMENTS



can you engineer a feeling?

Equipment and technology begin with some pretty simple principles of engineering.
Like, can it make your yacht feel better on the water and in your hands? Enjoy.

