

Latitude 38

OCTOBER 2010

VOLUME 400

# Latitude 38

VOLUME 400 October 2010

WE GO WHERE THE WIND BLOWS

OUR  
400<sup>TH</sup>  
ISSUE!

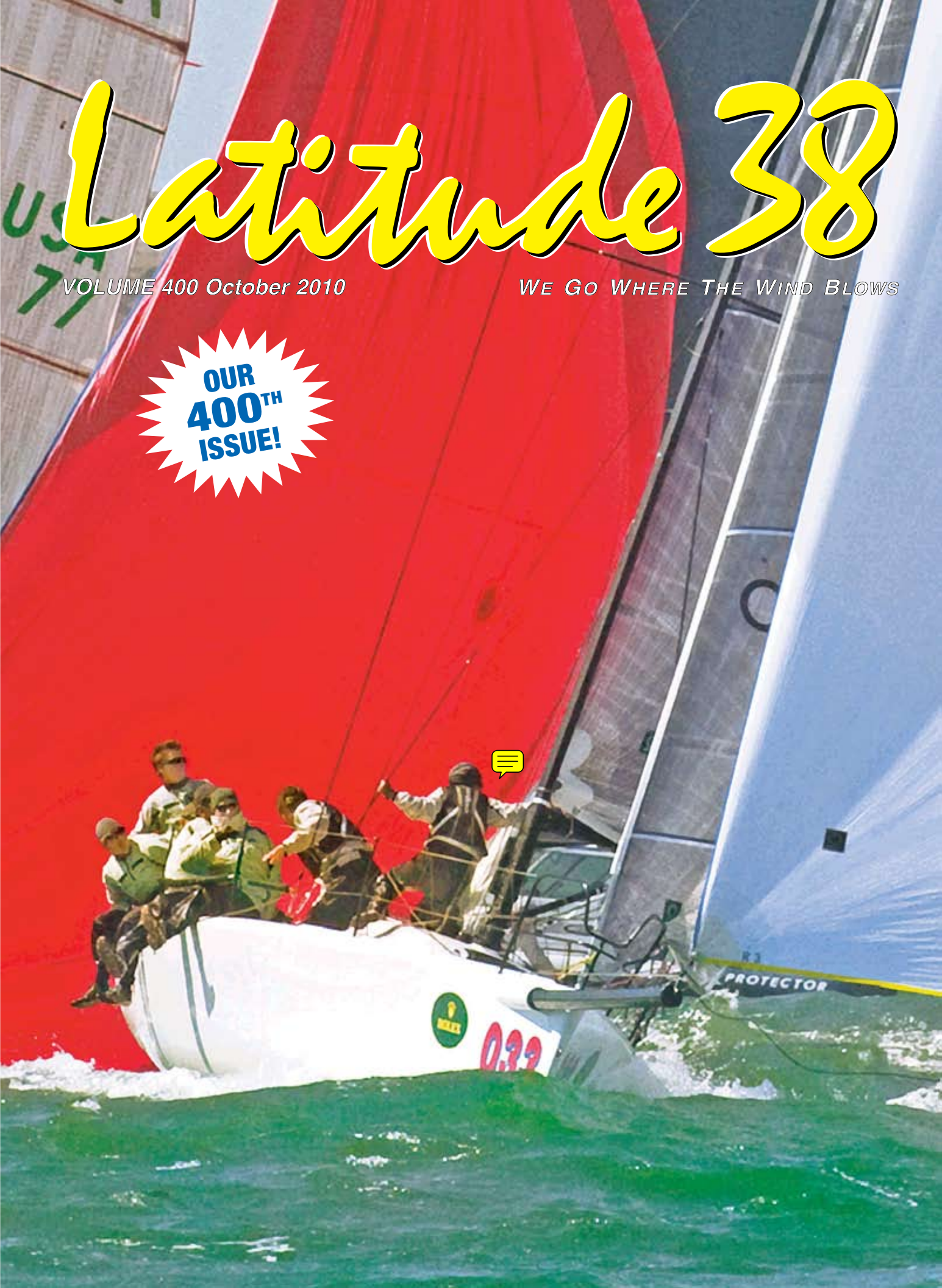

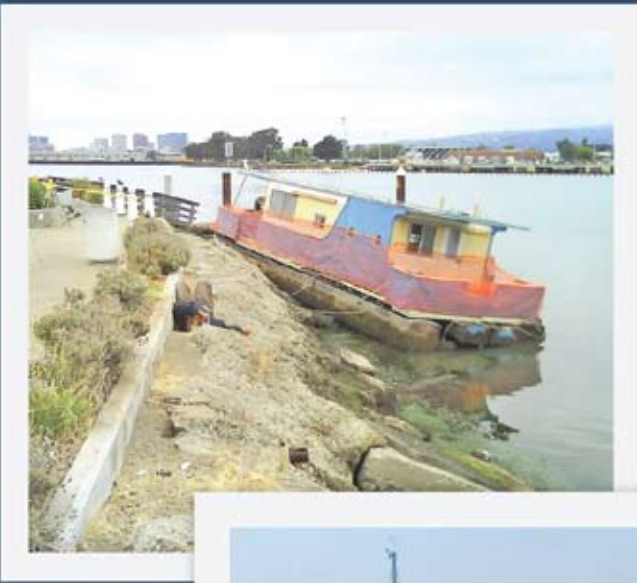

Too many  
undesirable  
elements collecting  
in your marina?



**GRAND MARINA. Safe, secure, clean, and beautiful.**

- Prime deep water concrete slips in a variety of sizes
- Great Estuary location at the heart of the beautiful Alameda Island
- Complete bathroom and shower facility, heated and tiled
- FREE pump out station open 24/7
- Full Service Marine Center and haul out facility
- Free parking
- Free WiFi on site!
- And much more...

<b>DIRECTORY of GRAND MARINA TENANTS</b>	
Bay Island Yachts .....	8
Blue Pelican Marine.....	176
The Boat Yard at Grand Marina ...	21
Lee Sails.....	149
Marine Lube.....	149
Pacific Crest Canvas.....	63
Pacific Yacht Imports .....	12
Rooster Sails .....	77



**GRAND MARINA**

ANDERSON-ENCINAL

**510-865-1200**

Leasing Office Open Daily  
2099 Grand Street, Alameda, CA 94501  
[www.grandmarina.com](http://www.grandmarina.com)

# A Family Affair

Ashley Perrin and “kid” brother Myles were the only sister/brother team sailing in this year’s Round Britain and Ireland Yacht Race, sailing their dad’s Capo 30, *Santana*. The race was sailed by 60 boats, all doublehanded, covering 2500 miles in everything from glassy calm conditions to gusty winds and large seas.

2500 miles of sailing provides plenty of memorable moments. “Mum and Dad” showing up at the various stops with home cooked meals...A bit of sibling bickering...Sailing for hours in the middle of the night in 30 knots of wind with a well behaved Pineapple spinnaker. “Loved the Pineapple spinnaker.”

*Santana* placed 1st in class 4 and won line honors at every stop.

*Santana*’s Pineapple Sails have served the Perrins well, over many years and many miles. Whether you are sailing around the Bay, around a country or two, or around the world, our commitment is to quality and performance.

Give us a call.

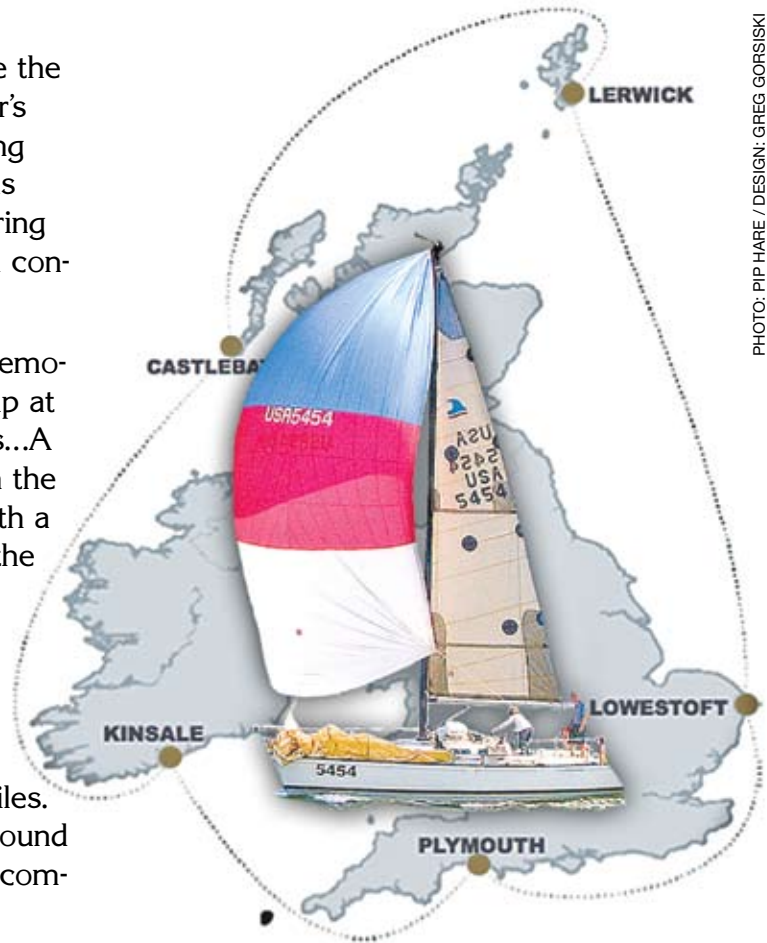

PHOTO: PIP HARE / DESIGN: GREG GORSISKI

***Santana***\*

YOUR DEALER FOR: Musto foul weather gear, Dubarry footwear and Headfoil 2

Sails in need of repair may be dropped off at:  
West Marine in Oakland, Alameda, or Richmond;  
or Svendsen’s in Alameda.

\*Powered by Pineapples



## **PINEAPPLE SAILS**

Phone (510) 522-2200

Fax (510) 522-7700

[www.pineapplesails.com](http://www.pineapplesails.com)

2526 Blanding Ave., Alameda, California 94501

# BOAT LOANS

*from*



Trident Funding

*"a fresh  
approach  
from people  
you can trust"*

*In Northern California call  
JOAN BURLEIGH  
(800) 690-7770*

*In Southern California call  
JEFF LONG  
MARGE BROOKSHIRE  
(888) 883-8634*

[www.tridentfunding.com](http://www.tridentfunding.com)

## CONTENTS

subscriptions	6
calendar	12
letters	22
loose lips	78
sightings	80
rolex big boat series	94
passin' through	104
tips on cheap cruising	110
baja ha-ha profiles, pt. II	116
max ebb: the wavy train	126
the racing sheet	130
world of chartering	142
changes in latitudes	150
classy classified	168
advertisers' index	180
brokerage	182

Cover: 32 Melges 32s hit the circle for their world championships.

Photo: Erik Simonson/[www.h2oshots.com](http://www.h2oshots.com)

Copyright 2010 Latitude 38 Publishing Co., Inc.

*Latitude 38* welcomes editorial contributions in the form of stories, anecdotes, photographs – anything but poems, please; we gotta draw the line somewhere. Articles with the best chance at publication must 1) pertain to a West Coast or universal sailing audience, 2) be accompanied by a variety of pertinent, in-focus digital images (preferable) or color or black and white prints with identification of all boats, situations and people therein; and 3) be legible. These days, we prefer to receive both text and photos electronically, but if you send by mail, anything you want back must be accompanied by a self-addressed, stamped envelope. **Submissions not accompanied by an SASE will not be returned.** We also advise that you not send original photographs or negatives unless we specifically request them; copies will work just fine. Notification time varies with our workload, but generally runs four to six weeks. Please don't contact us before then by phone or mail. Send all submissions to [editorial@latitude38.com](mailto:editorial@latitude38.com), or mail to Latitude 38 editorial department, 15 Locust Ave., Mill Valley, CA 94941. For more specific information, request writers' guidelines from the above address or see [www.latitude38.com/writers.html](http://www.latitude38.com/writers.html).

# Making Their U.S. Debut at the Annapolis Boat Show: Exciting New Models from Beneteau



**Beneteau Sense 50**

Beneteau has just introduced its newest line of boats with a whole new direction for living onboard in the 'open'. Life onboard SENSE is organized around:

- An innovative and spacious cockpit design and innovative deck layout
- Luxurious accommodations with tremendous storage
- Adapted to tomorrow's technologies

**U.S. debut at the Annapolis Sailboat Show October 7!**



**Beneteau First 30**



**Beneteau First 35**



**Beneteau Oceanis 58**



**Beneteau Oceanis 50**

## OCTOBER EVENTS

### BENETEAU RENDEZVOUS

OCT. 1-3 ■ Pt. Richmond

### ANNAPOLIS BOAT SHOW

OCT. 6-10 ■ Debut of new Beneteau models

### OPEN BOAT WEEKEND

OCT. 9-10

Marina Village, Alameda

### FIRST 30 FLEET FOUNDING MEETING

OCT. 15 ■ Encinal YC

## FALL PRICING SPECIALS

In effect until October 30



1220 Brickyard Cove Rd  
Pt. Richmond, CA  
p: 510-236-2633  
f: 510-234-0118

1070 Marina Village Pkwy #101  
Alameda, CA  
p: 510-864-3000  
f: 510-337-0565

[www.passageyachts.blogspot.com](http://www.passageyachts.blogspot.com) ■ [www.passageyachts.com](http://www.passageyachts.com)

## SELECT LISTINGS



**Beneteau 423, 2005**  
\$199,999



**Island Packet 40, 1998**  
\$225,000



**46' Amel Maramu, 1985**  
\$125,000



**39' Carroll Marine CM 1200**  
1995, \$59,900



**Catalina 36**  
Two from \$63,500



**C&C 35 MkII, 1983**  
\$51,900

### SAIL

50' Chinese Junk	1972	\$325,000
50' Hollman	1989	169,950
49' Beneteau 49	2009	380,000
47' Beneteau 473	2004	275,000
47' Beneteau 473 3-cabin	2006	329,000
47' Beneteau 473 3-cabin	2004	269,000
47' Beneteau First 47.7	2001	197,000
46' Amel Maramu	1985	125,000
46' Island Packet 465	2008	594,500
45' Beneteau First 45f5	1991	157,500
44' Tartan 4400	2003	439,000
43' Gulfstar CC	1979	85,000
42' Beneteau 423	2005	199,999
42' Cascade	1971	47,500
41' Tartan 4100	1996	224,500
40' Beneteau First 40	2010	276,394
40' C&C 37+	1989	96,000
40' Hardin Seawolf ketch	1970	70,000
40' Island Packet	1998	225,000
39' Carroll CM 1200	1995	59,900
38' Island Packet 380	1999	239,000
38' Tartan 3800	1995	129,000
37' C&C 37	1985	59,900
37' Pacific Seacraft	1984	129,000
37' Tartan 3700	2006	239,000
36' Cape Dory ketch	1984	89,900
36' CS Merlin	1988	62,500
36' Island Packet 350	1999	169,000
35' C&C 35 Mk III	1983	51,900
35' Dehler 35 CWS	1996	82,000
35' J/109	2003	160,000
35' Tung Hwa Fantasia	1979	74,900
34' Beneteau 343	2007	114,500
32' J/32	1997	87,500
31' Beneteau 31	2009	125,485
31' Beneteau First 310	1993	46,900
30' Juno Produktor Tore Holm sloop	1960	48,000

### POWER

42' Californian aft cabin	1987	119,950
38' PC True North	2007	369,000
34' Sea Ray 340	2006	134,900

## THINKING USED BOAT?

Stop by our Alameda  
Brokerage Office  
Open 7 Days a Week  
Large Selection  
Financing & Insurance Services

Expand your experience on the water.



## Meet the R27 Trailable Tug.

Nearly 50 sq. ft. of deck space – 25% larger than our original R25 – means easy access to the standard 180 HP Yanmar diesel, more storage, and a midship office with desk and chair. Cooks will love the full-service galley, while at the helm, standard bow and stern thrusters let you maneuver in even the tightest spaces. Solar panels are an option for 2011 on all Ranger models, including the new R27.

Come to Farallone Yacht Sales of Alameda and check out Ranger's Bristol Bay-inspired trawlers. We're the exclusive California dealer for Ranger Trailable Tugs, a family-owned company designing and building quality boats in the U.S. since 1958.

## Come see the new Ranger Tugs! Open Boat Weekend • October 8-9-10

### New Ranger Tugs in Stock (base price)

Ranger 29 Tug, 2011 ..... **JUST ARRIVED** .....\$224,937  
 Ranger 27 Tug, 2011 ..... **NEW MODEL!** .....149,937  
 Ranger 25-SC Tug, 2010..... **NEW MODEL!** .....129,937  
 Ranger 21-EC Tug, 2011. **ARRIVING THIS MONTH**..49,937

### Preowned Ranger Tugs at Our Docks

Ranger 29, 2010.....\$239,967  
 Ranger 25 Tug, 2010 .....145,000  
 Ranger 25 Tug, 2009 .....130,000  
 Ranger 21 Tug, 2009 .....50,000



**F A R A L L O N E**

Alameda (510) 523-6730  
 Newport Beach (949) 610-7190  
 San Diego (619) 523-6730

[www.faralloneyachts.com](http://www.faralloneyachts.com)

# SUBSCRIPTIONS

**YOU CAN NOW PAY FOR SUBSCRIPTIONS ONLINE! Check out our website.**

*Please allow 4-6 wks to process changes/additions, plus delivery time.*

eBooks email list. **Free!**

See [www.latitude38.com](http://www.latitude38.com) to download the entire magazine for free! Our eBooks are in PDF format, easy to use with Adobe Reader.

Email: \_\_\_\_\_

Enclosed \$36 for one year Third Class Postage (Delivery time 2-3 weeks; Postal Service will not forward third class; make address changes with us in writing.)

Enclosed \$55 for one year First Class Postage (Delivery time 2-3 days.)

Third Class Renewal  First Class Renewal (**current subs. only!**)

Gift Subscription Card to read from: \_\_\_\_\_

**NOTE: FPO/APO (military), Canada, Mexico, and subscriptions going to a correctional facility are first class only. Sorry, no foreign subscriptions.**

Name \_\_\_\_\_

Address \_\_\_\_\_

City \_\_\_\_\_ State \_\_\_\_\_ Zip \_\_\_\_\_

Phone: ( ) \_\_\_\_\_ Email: \_\_\_\_\_

**CREDIT CARD INFORMATION**  MASTERCARD  VISA  AMERICAN EXPRESS  
**Min. Charge \$12** Number: \_\_\_\_\_ Exp.: \_\_\_\_\_ csv: \_\_\_\_\_

## INDIVIDUAL ISSUE ORDERS

**Current issue = \$6.00 • With classy ad placed = \$5.00**

**Back Issues = \$7.00 (must indicate exact issue by month or vol. #)**

## DISTRIBUTION

We have a marine-oriented business/yacht club in California which will distribute copies of *Latitude 38*. (Please fill out your name and address and mail it to the address below. Distribution will be supplied upon approval.)

Please send me further information for distribution outside California

Business Name \_\_\_\_\_ Type of Business \_\_\_\_\_

Address \_\_\_\_\_

City \_\_\_\_\_ State \_\_\_\_\_ Zip \_\_\_\_\_

County \_\_\_\_\_ Phone Number \_\_\_\_\_

# Latitude 38

*"we go where the wind blows"*

Publisher/Exec. Editor ..... Richard Spindler ..... [richard@latitude38.com](mailto:richard@latitude38.com) ..... ext. 111  
 Associate Publisher..... John Arndt ..... [john@latitude38.com](mailto:john@latitude38.com) ..... ext. 108  
 Managing Editor ..... Andy Turpin ..... [andy@latitude38.com](mailto:andy@latitude38.com) ..... ext. 112  
 Editor ..... LaDonna Bubak ..... [ladonna@latitude38.com](mailto:ladonna@latitude38.com) ..... ext. 109  
 Racing Editor ..... Rob Grant ..... [rob@latitude38.com](mailto:rob@latitude38.com) ..... ext. 105  
 Contributing Editors ..... John Riise, Paul Kamen  
 Advertising Sales ..... John Arndt ..... [john@latitude38.com](mailto:john@latitude38.com) ..... ext. 108  
 Advertising Sales ..... Shawn Grassman ..... [shawn@latitude38.com](mailto:shawn@latitude38.com) ..... ext. 107  
 General Manager ..... Colleen Levine ..... [colleen@latitude38.com](mailto:colleen@latitude38.com) ..... ext. 102  
 Production/Web ..... Christine Weaver ..... [chris@latitude38.com](mailto:chris@latitude38.com) ..... ext. 103  
 Production/Photos..... Annie Bates-Winship ..... [annie@latitude38.com](mailto:annie@latitude38.com) ..... ext. 106  
 Bookkeeping..... Jessie Mowry ..... [jessie@latitude38.com](mailto:jessie@latitude38.com) ..... ext. 101

Directions to our office..... press 4  
 Subscriptions..... press 1,4  
 Classified..... [class@latitude38.com](mailto:class@latitude38.com) ..... press 1,1  
 Distribution ..... [distribution@latitude38.com](mailto:distribution@latitude38.com) ..... press 1,5  
 Editorial ..... [editorial@latitude38.com](mailto:editorial@latitude38.com) ..... press 1,6  
 Calendar..... [calendar@latitude38.com](mailto:calendar@latitude38.com)  
 Other email..... [general@latitude38.com](mailto:general@latitude38.com)

**Please address all correspondence by person or department name**

15 Locust Avenue, Mill Valley, CA 94941 • (415) 383-8200 Fax: (415) 383-5816  
[www.latitude38.com](http://www.latitude38.com)

# Catalina Sailboats Built for performance and pleasure – and value.

Catalina's philosophy is simple: Design boats to sail well and stand up to real world conditions. Make them comfortable and easy to maintain. And be sure they hold their value. That's why the closer you look at Catalina sailboats, the better they get – like the award-winning 445 at our docks now.

For over 35 years, Farallone Yachts of Alameda has been known for superior product knowledge, unparalleled service, and exceptional customer satisfaction. We're the exclusive Bay Area dealer for Catalina Sailing Yachts, the largest privately owned and operated manufacturer of U.S.-built sailing yachts in the world.



Best Full-Size  
Cruiser



Best Cruising Monohull  
Under 50 ft.

Come Walk  
Our Docks!  
Open Boat Weekend  
October 8-9-10

Catalina  Yachts

**BOATS ARE SELLING • LIST WITH US • TEN BOATS SOLD SINCE AUGUST!**

**New Catalina Yachts in Stock**

Catalina 445, 2010  
Catalina 375, 2010

**Preowned Catalina Yachts at Our Docks**

Catalina 42, 1993 .....	\$128,500
Catalina 42, 1996 .....	155,000
Catalina 400, 2004 .....	220,000
Catalina 400, 2001 .....	159,000
Catalina 400, 1997 .....	139,500
Catalina 36 MkII, 2005 .....	129,000
Catalina 36 MkII, 2004 .....	127,777
Catalina 36 MkII, 1999 .....	98,000
Catalina 36, 1986 .....	54,000
Catalina 36, 1983 .....	37,000

Catalina 350, 2004 .....	144,500
Catalina 350, 2004 .....	127,500
Catalina 350, 2008 .....	169,500
Catalina 34, 2007 .....	134,500
Catalina 34, 2004 .....	114,500
Catalina 320, 2004 .....	115,000
Catalina 320, 2000 .....	74,900
Catalina 320, 1999 .....	83,750
Catalina 310, 2007 .....	104,000

**Preowned Sailing Yachts at Our Docks**

Cavalier 45, 1985 .....	199,500
Hunter 42, 1994 .....	124,500
Fair Weather 39, 1985 .....	99,900
Hunter 37, 1987 .....	61,500

Hunter 36, 2004 .....	119,000
Islander 36, 1977 .....	39,900
Hunter 31, 2007 .....	84,900
Nonsuch 30, 1981 .....	49,000

**New Ranger Tugs in Stock (base price)**

Ranger 29 Tug, 2011 .....	<b>JUST ARRIVED</b> .....\$224,937
Ranger 27 Tug, 2011 .....	<b>NEW MODEL!</b> .....149,937
Ranger 25-SC Tug, 2010 .....	<b>NEW MODEL!</b> .....129,937
Ranger 21-EC Tug, 2011 .....	<b>ARRIVING THIS MONTH</b> ..49,937

**Preowned Ranger Tugs at Our Docks**

Ranger 29, 2010 .....	\$239,967
Ranger 25 Tug, 2010 .....	145,000
Ranger 25 Tug, 2009 .....	130,000
Ranger 21 Tug, 2009 .....	50,000



1070 Marina Village Pkwy  
Alameda, CA 94501  
(510) 523-6730

2801 West Coast Hwy  
Newport Beach, CA 92663  
(949) 610-7190

2353 Shelter Island Dr  
San Diego, CA 92106  
(619) 523-6730

F A R A L L O N E [www.faralloneyachts.com](http://www.faralloneyachts.com)

VISIT US ONLINE AT [WWW.BAYISLANDYACHTS.COM](http://WWW.BAYISLANDYACHTS.COM)



**PDQ 36**



NEW LISTING

1991, \$154,900

**MOORINGS 43**



1986 BENEteau, \$59,900

**TAYANA 48 DS**



2003, \$429,000

**FORMOSA 51**



1979, \$75,000

**C&C 32**



1984, \$31,500

**NORWEST 33**



1979, \$35,000

SISTERSHIP

**32' WESTSAIL**



1974. Perfect! \$74,900

**C&C 41**



1984, \$73,000

SISTERSHIP

**PETERSON 44**



1976, \$115,000

SISTERSHIP

**45' JOURNEY LR CAT**



Wave Piercing Bows  
High Cruising Speeds  
3 nautical miles  
per gallon at 15 knots  
Proven Offshore Design  
[journey@bayislandyachts.com](mailto:journey@bayislandyachts.com)  
<http://journeycatamarans.com>

In Grand  
Marina

**(510) 814-0400**

Fax (510) 814-8765

2099 Grand Street, Alameda, CA 94501

[www.bayislandyachts.com](http://www.bayislandyachts.com)

[yachtsales@bayislandyachts.com](mailto:yachtsales@bayislandyachts.com)

**YACHTWORLD.com**



"The chief mate of the Pequod was Starbuck, though born on an icy coast, seemed well adapted to endure hot latitudes...He was by no means ill-looking; quite the contrary. His pure tight skin was an excellent fit; and closely wrapped up in it. Starbuck seemed prepared to endure for long ages to come, and to endure always, as now; for be it Polar snow or torrid sun, like a patent chronometer, his interior vitality was warranted to do well in all climates."

— Herman Melville, 'Moby Dick', Chapter XXVI



**CLASSIC CANVAS  
STARBUCK CANVAS WORKS**  
**415-332-2509**

67 Liberty Ship Way, Sausalito, CA 94965



Now in our 42nd year!

See us at the  
**Annapolis  
Boat Show**  
Booth K-11

All Mack Sails are **Built to Last**  
*...and designed to be Fast*



Every  
Mack Sail  
is  
Made in  
Our  
Stuart, Fla.  
Sail Loft



Colin Mack and Travis Blain  
Partners in Mack Sails

High Quality and Great Customer Service  
Have Certainly Made Mack Sails...

*the Biggest Small Loft in the USA*



3129 SE DOMINICA TERR.  
STUART, FL 34997  
(772) 283-2306  
FAX (772) 283-2433

(800) 428-1384  
(772) 283-2306  
[INFO@MACKSAILS.COM](mailto:INFO@MACKSAILS.COM)  
[WWW.MACKSAILS.COM](http://WWW.MACKSAILS.COM)

Also See Us for Rigging, Hardware and Electronics — We Ship Everywhere





**Cruising Yachts, Inc.**

**Exclusive Dealer for Hunter, Jeanneau and Caliber Yachts**

**Half Moon Bay Rendez-BOO Cruise!**

**October 22-24, 2010**

**Call us for details**



**Just Arrived! 2011 Hunter 39**



**Just Arrived! 2011 Hunter 45DS**



**New Design! Jeanneau 42DS**



**New Model! Jeanneau 53**

**PRE CRUISED SPECIALS**

2006 Jeanneau 54 DS	\$549,000
2009 Jeanneau 50 DS	\$427,000
2008 Hunter 49	\$369,000
2000 Hunter 460	\$210,000
2004 Hunter 466	\$217,900
2003 Hunter 466	\$219,000
2007 Hunter 45 CC	\$275,000
1999 Hunter 450	\$189,000
1992 Morgan 45 CC	\$134,000
1983 Morgan Nelson 45	\$109,000
2005 Beneteau 44.7	\$235,000
2004 Hunter 420	\$195,000
2005 Bavaria 42	\$175,900
2007 Beneteau 423	\$219,900
1997 Catalina 42 MKII	\$138,500
2003 Hunter 426	\$188,000
1999 Hunter 420	\$120,000

**PRE CRUISED SPECIALS**

2005 Hunter 41	\$179,900
2005 Hunter 41 DS	\$187,000
1983 Newport 41 MK II	\$39,950
2008 Beneteau 40	\$189,000
1986 Beneteau 40.5	\$59,900
1993 Hunter 40.5	\$104,000
1980 Islander 40	\$69,900
1986 Passport 40	\$149,500
1930 Sloop 30 Square Mtr.	\$60,000
2003 Beneteau 393	\$135,000
2009 Jeanneau 39i	\$199,000
2009 Hunter 38	\$195,000
2006 Hunter 38	\$159,500
2000 Hunter 380	\$99,500
2004 Hunter 386 LE	\$130,500
1996 Hunter 376	\$85,000
1967 Tartan 37	\$35,000

**PRE CRUISED SPECIALS**

1995 Catalina 36 MKII	\$78,500
2000 Catalina 36 MKII	\$74,500
2007 Hunter 36	\$149,995
1994 Hunter 35.5	\$59,900
1992 Hunter 35.5	\$69,000
2004 Jeanneau 35	\$114,995
2002 Beneteau 331	\$74,500
2004 Hunter 33	\$89,900
1994 Hunter 33.5	\$48,750
1995 Hunter 33.6	\$52,900
1995 Catalina 320	\$59,500
1978 Dreadnought Ketch 32	\$29,800
2001 Hunter 320	\$54,900
2003 Hunter 326	\$59,900
1990 Hunter 32	\$35,750
2007 Hunter 31	\$89,900
2001 Hunter 290	\$49,900

**San Diego**  
(619) 681-0633

**Newport Beach**  
(949) 650-7245

**Alameda**  
(510) 521-5544

**Marina del Rey**  
(310) 822-9400

**Oxnard**  
(805) 791-2082

**[www.CruisingYachts.net](http://www.CruisingYachts.net)**

# SAIL MORE

## New Wyliecat 40

Displacement - 11,360  
Ballast - 6,360 (56%)  
Sail - 953 sq. feet

USCG Certificate of Inspection (COI) up to 25 passengers. Or go for a spin...solo.



## bemark YACHTS

HANSE AND WYLIECAT YACHTS  
AND SELECT BROKERAGE BOATS

310 Harbor Dr. Sausalito, CA  
415/332/2290

Larry R. Mayne 650/888/2324  
Dealer for Hanse of Northern  
California and Wyliecat Yachts  
hansenorcal.com

George Higbie 415/672/4123  
georgehigbie@mac.com

John Saul 415/332/6585  
bemarkyachts@gmail.com

## Yachtfinders/Windseakers in the heart of San Diego's boating community

2330 Shelter Island Dr. # 207, San Diego, CA 92106

info@yachtfinders.biz

(619) 224-2349

Toll Free (866) 341-6189

Go to  
[www.yachtfinders.biz](http://www.yachtfinders.biz)  
for all our 80+ listings!



47' BENETEAU 473, '04 \$249,000

This is an opportunity to own a magnificent, like-new Beneteau. She is ocean-going, fast, good looking, spacious, and very powerful.



45' HUNTER CC, '06 \$329,000

All the bells and whistles, and fewer than 100 engine hours. Owner is open to all offers. Bank will entertain short-sale offers.



45' MORGAN CC, '94 \$154,500

If you are searching for a beautiful yacht with a class feel to her and loads of space with a huge owner's stateroom, you've found her.



42' MULL, '85 \$140,000

Gary Mull designed a boat suited for our unique conditions on San Francisco Bay and with exceptional offshore capabilities.



42' PASSPORT, '81 \$118,500

As a testament to the success of the design, there's a high percentage of Passport 42 owners who have done extended offshore cruising.



38' ERICSON, '84 \$49,500

Bruce King designed a winner for both racing and cruising with this boat. Enjoy respectable performance and a comfortable layout.



36' CATALINA, '90 \$64,900

She shows well, as expected of a fresh-water yacht hauled annually for storage while home-ported in the Great Lakes. Now in California.



35' COOPER 353, '81 \$69,000

Designed by northwest naval architect Stan Huntingford and built in the reputable yard that makes Maple Leafs and Sceptre 41s.



32' ERICSON 32-200, '88 \$38,500

A very knowledgeable sailor set this boat up for extensive sailing trips. She would be an excellent boat for the Baja Ha-Ha and beyond!



30' HUNTER, '79 \$18,400

Great cruiser with diesel engine, simple, rigging and comfortable layout. Eight opening ports and two hatches for excellent ventilation.



29' LANCER, '78 \$9,400

This one is very clean, very pretty, and a very good deal. The sails, rig and hull appear to be in great shape. Check her out!



28' LIBERTY CUTTER, '80 \$29,500

Low engine hours and a full complement of like-new working sails. Pretty dark green hull and freshly painted decks this year.

San Francisco's yacht broker since 1969 ~ celebrating our 40th year!

# Cityyachts YACHTS AND THE CITY



Beneteau 370, 1991 \$79,000

**WE ARE  
OPEN DAILY  
9:00 A.M.  
to  
5:00 P.M.**



33' Hunter Sloop, 1980 \$29,900



Cal 39, 1979 \$34,000



Beneteau 33, 2002 \$78,500



Hinterhoeller 26C Nonsuch, 1981 \$25,000



46' Moody, 2000 \$397,000



Newport 30 MkIII, 1982 \$23,500



30' Cape Dory, 1978 \$32,500



Carver 30, 1993 \$59,900



47' Chris Craft Commander, '74 \$122,000



28' Blackfin, 1981, \$29,000

**10 MARINA BL. • SAN FRANCISCO, CA 94123 • Toll Free: 877-444-5091 • 415-567-8880**  
**FAX (415) 567-6725 • email: sales@citysf.com • website: www.citysf.com**



**PLEASE VISIT OUR FUEL DOCK AT GASHOUSE COVE MARINA • OPEN 7 DAYS A WEEK • 9AM TO 5PM**

# CALENDAR

## Non-Race

**Oct. 1** — Defibrillator & CPR training at San Joaquin YC, 3-6 p.m. Every cruiser should know CPR, and defibrillators are an essential part of a well-stocked med kit. Info, (925) 308-4920.

**Oct. 1-3** — Westsail Owners Rendezvous at San Leandro YC. Info, [www.westsail.org/\\_rendv/\\_canorth/index.html](http://www.westsail.org/_rendv/_canorth/index.html).

**Oct. 2** — Redwood City PortFest, a showcase of the waterfront. Live music, kids' activities, food, and beer garden. Info, [www.redwoodcityport.com](http://www.redwoodcityport.com) or (650) 306-4150.

**Oct. 2** — Pegasus Project Celebration Dinner at Berkeley YC with keynote speaker Mark Schrader of 'Around the Americas', 5-9:30 p.m. \$15 for BYC members & pre-sale, \$25 at the door. Proceeds go to Pegasus Project. Silent auction and raffle. Info, (510) 205-1069 or [www.pegasusproject.org](http://www.pegasusproject.org).

**Oct. 2, 16, 23, 30** — Sail aboard San Francisco Maritime National Historic Park's scow schooner *Alma*. Learn the Bay's history on this 3-hour voyage, leaving Hyde St. Pier at 1 p.m. \$40 adults, \$20 kids 6-15. Info, [www.nps.gov/safr](http://www.nps.gov/safr).

**Oct. 3-31** — Free sailing at Pier 40 every Sunday courtesy of BAADS. Info, (415) 281-0212 or [www.baads.org](http://www.baads.org).

**Oct. 6-27** — Wednesday Yachting Luncheon Series at St. Francis YC, 12-2 p.m., \$13.50. Enjoy lunch and a dynamic speaker every Wednesday. All YCs' members welcome. More info under the 'Events' tab at [www.stfyc.com](http://www.stfyc.com).

**Oct. 7** — 'Safely Sharing the Bay' by Capt. Peter Leib of Club Nautique at San Carlos West Marine, 6-8 p.m. Free. Info, (650) 593-2070.

**Oct. 7-11** — 41st Annual United States Sailboat Show, a.k.a. the Annapolis Boat Show. Info, [www.usboat.com](http://www.usboat.com).

**Oct. 7-12** — Hey, sailor, it's Fleet Week featuring the Blue Angels. Details can be found at [www.fleetweek.us](http://www.fleetweek.us).

**Oct. 9** — Martinez Marina Nautical Swap Meet from 8 a.m.-2 p.m. The last of the year. Info, (925) 313-0942.

**Oct. 9-10** — 18th Annual Northern California Women's Sailing Seminar at Island YC. Info, [www.iyc.org/wss.html](http://www.iyc.org/wss.html).

**Oct. 10** — Watch the final performance of the Blue Angels from the deck of *Gas Light*, the 72-ft replica of a scow schooner. \$85/person. Youth scholarship fundraiser. Info, [www.ggtss.org](http://www.ggtss.org), [acochran@pacbell.net](mailto:acochran@pacbell.net), (415) 251-8779.

**Oct. 12-Nov. 5** — *Lady Washington* and *Hawaiian Chieftain* return to the Bay and will offer tours. For dates, times, and details on booking passage, see [www.historicalseaport.org](http://www.historicalseaport.org).

**Oct. 14, 1882** — Legendary naval architect and writer William 'Billy' Atkin was born in the Big Apple.

**Oct. 14** — Single sailors of all skill levels are invited to the Single Sailors Association monthly meeting at Ballena Bay YC, 7:30 p.m. Info, [www.singlesailors.org](http://www.singlesailors.org) or (510) 233-1064.

**Oct. 16** — Ha-Ha Welcome to San Diego Party at Downwind Marine, 12-4 p.m. Info, [www.baja-haha.com](http://www.baja-haha.com).

**Oct. 16** — GPS for Mariners by USCGA Flotilla 17 on Yerba Buena, 8:30 a.m.-5 p.m. \$55. Info, [FSO-PE@flotilla17.org](http://FSO-PE@flotilla17.org).

**Oct. 16** — Chula Vista Marina's Swap Meet, 7 a.m.-12



### TAYANA 48 DECK SALON



**Tayana 54**  
**Tayana 58**  
**Tayana 64**  
**Tayana 72**



**1983 TAYANA 55**  
Just returned from the South Pacific. New LPU. Fully equipped. **\$315,000**



**2006 TAYANA 48 CC** South Pacific vet with everything you need to go. 3 stateroom version in great shape. **\$425,000**



**1997 TARTAN 4600**  
Custom Kevlar reinforced hull. Beautifully maintained. **\$299,500**



**2005 TAYANA 48 CC**  
Mexico vet. In great shape and loaded with everything you need. **\$469,000**



**1987 MORGAN CLASSIC 41**  
Hard dodger with full enclosure, solar, Yanmar diesel, autopilot, color plotter. **\$75,000**



**1984 TAYANA 37**  
This is the one you want. Perfect shape with lots of new upgrades and electronics! **\$129,500**



**1974 CHEOY LEE MIDSHIPMAN**  
Live aboard or cruise in this roomy CC ketch. 160 hours on 56hp Yanmar. **\$69,000**



**1979 BABA 30**  
Traditional Bob Perry cruiser in 30 feet. Clean and ready to sail. **\$54,900**

# Pacific Yacht Imports

[www.pacificyachtimports.net](http://www.pacificyachtimports.net)

Grand Marina • 2051 Grand St., Alameda, CA 94501  
Tel (510) 865-2541 • [tayana@mindspring.com](mailto:tayana@mindspring.com)



LATITUDE / JR

**Don't let the Blue Angels fly away without getting out on the Bay for the show.**



### MAZATLAN

Ray Watson & Jeannette Sarrasin  
 Toll free US/CAN:  
 1 (888) 716-7430  
 Phone/FAX:  
 011 52 (669) 913-3165  
 Email: Mazmarine@aol.com

### LA PAZ

Mike Rickman & Shelly R. Ward  
 Toll free US/CAN:  
 1 (877) 245-9689  
 Phone/FAX:  
 011 52 (612) 123-1948  
 Email: LaPazYachts@aol.com

### PUERTO VALLARTA

Clive & Theresa Sands  
 Toll free US/CAN:  
 1 (866) 573-1303  
 Phone/FAX:  
 011 52 (322) 297-4639  
 Email: PVYachtSales@aol.com

**WE SELL MORE BOATS THAN ANY OTHER BROKER IN MEXICO**



42' SPENCER SLOOP, 1974...\$75,000



42' CHEOY LEE GOLDEN WAVE, 1981...\$119,900



44' NORSEMAN 447 CC, 1984...\$259,000



57' BAYLINER 5788, 1998, Defiance...\$399,995

**Make your Mexican dream come true!**  
 Check out all listings at  
**www.mazmarine.com**



40' BRUCE ROBERTS CUTTERS...2 from \$79,000



42' CATALINA, 1991, 2-cabin...\$125,000



44' KELLY PETERSON CC, 1980...\$145,000



29' ROBALO SPORTFISHERS, MUST SELL! Both for \$70,000

**We Have The Boats! • All We Need Is YOU!**

## ACTIVITIES at MARINA MAZATLAN NOVEMBER thru APRIL

*Most of these events were brought to you compliments of*

**Mazatlan Yachts ~ Marina Services Mazatlan, Rick ~ Tony's Boat Management**

*Three great reasons to come to Marina Mazatlan!*

- Mazatlan Art Festival
- Thanksgiving Day Dinner and Dance
- Rick's Welcome Back Cruisers Tuna Night
- Pizza Night
- Pro-Mexico Christmas Bazaar
- New Year's Eve at Chili's Pepper
- Chili Cook-off and Bloody Mary Contest
- Music Hour Jam Sessions
- Dr. Levid talk on Health & Medicine
- Children's Day
- Pro-Mexico House Tour
- Carnival in Mazatlan third largest in the world
- Salsa Dance Lessons
- Coffee and cookies Wednesday mornings at Calypso Coffee Bar

*For more information call Toll Free (888) 716-7430*

**www.mazmarine.com**

## UniPower™ 900 Electric Radial® Winch

# Cabintop Powerhouse

© Yves RONZIERE / DURFOUR photo



**Stop sweating your halyards.** With a Harken UniPower™ 900 electric winch on your cabintop, you'll be able to raise your sails with the touch of a button. Even small yachts can now enjoy this cabintop convenience—the UniPower™ has a partially embedded motor to preserve headroom below.

**Need a hand with your sheets?** The Harken UniPower™ 900 also makes a great single-speed mainsheet or primary winch for boats up to 13 m (43'). Unlike typical powered winches, it's an energy-efficient solution with no power lost to retrofit gearing.

### BIG POWER, BIG ENERGY SAVINGS

Nearly one short ton of pulling power with this high efficiency winch and motor

### INTEGRATED SAFETY

Electronically limited to 900 kg (1984 lb) to stop sheet jams from overloading other hardware

### RADIAL® WINCH TECHNOLOGY

Line-friendly grip, quick installation, and smooth easing

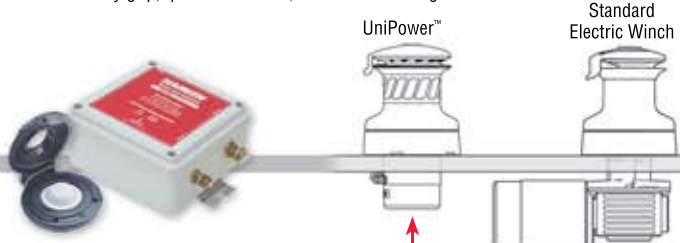

**MORE HEADROOM**  
New design saves between 50 and 83 mm (2"-3 1/4") of vertical headroom, perfect for smaller cabins

### FREE ACCESSORY KIT

UniPower™ winches include a waterproof switch and control box with electronic current limiter

# HARKEN®

INNOVATIVE SAILING SOLUTIONS

Tel: 262-691-3320, Email: harken@harken.com, Web: www.harken.com

## CALENDAR

p.m. Info, [boatslips@chulavistamarina.com](mailto:boatslips@chulavistamarina.com).

**Oct. 16-Nov. 13** — Boating Skills & Seamanship Course by USCGA Flotilla 12-3 on Coast Guard Island in Alameda, 9 a.m.-5 p.m. \$50 fee. Info, [uscga@att.net](mailto:uscga@att.net) or (510) 468-8013.

**Oct. 17** — 'Intro to Offshore Communications' by Gordon West & Shea Weston at San Diego (Rosecrans) West Marine, 3:30-5:30 p.m. Free. Info, [www.saildocs.com/sailmail/seminars](http://www.saildocs.com/sailmail/seminars).

**Oct. 18** — Downwind Marine's Cruisers' Seminar Series kicks off with Sailing Downwind: Techniques & Equipment, by Bruce Brown at Downwind Marine at 7:30 p.m., \$3. More seminars at same time and location. **10/19:** Cruising Mainland Mexico (Dick Markie); **10/20:** Outboard Motor Care for Cruising in Mexico (Tom Teevin); **10/21:** AIS: The Best Collision Avoidance System (Steven Gloor); **10/22:** Cruising the Sea of Cortez & Mexico (Shawn Breeding & Heather Bansmer); **10/26:** Staying Friends with Your Diesel Engine (CF Koehler); **10/28:** Solar Powered Battery Charging & Battery Systems (Rick Cullen); **10/28:** Cruising on 12 Volts (Barry Kessler); **10/29:** Cruising the Sea of Cortez & Mexico (Shawn Breeding & Heather Bansmer). Info, [www.downwindmarine.com](http://www.downwindmarine.com).

**Oct. 18** — 'Using Your Marine SSB Radio' by Gordon West & Shea Weston at San Diego (Rosecrans) West Marine, 1-5 p.m. \$25/person or \$30/couple. Reservations, [shea@yachtwire.net](mailto:shea@yachtwire.net).

**Oct. 19** — 'How to Get the Most Out of SailMail' by Jim & Sue Corenman and Shea Weston at Pt. Loma Assembly Hall in San Diego, 8:30 a.m.-4 p.m. \$50/person or \$75/couple. Reservations, [sysop@sailmail.com](mailto:sysop@sailmail.com).

**Oct. 21** — 'Emergencies at Sea' by John Connolly of Modern Sailing at San Carlos West Marine, 6-8 p.m. Free. Info, (650) 593-2070.

**Oct. 21** — Friends of SF Marina guest lecture by Dave Robinson of Sealife Conservation (sponsors of the Wyliecat 65 *Derek M. Baylis*) at Golden Gate YC, 6 p.m. Boat tours, no host bar and snacks. Donations welcome. Info, (415) 831-6322.

**Oct. 22** — Howl at the full moon on a Friday night.

**Oct. 24** — Sailing Speaker Series with Yoga for women. *Latitude's* Christine Weaver will discuss racing and cruising the Delta, 10 a.m.-noon at Bow Yoga Studio in San Rafael. \$30 for seminar, yoga and meditation classes. Info, (510) 333-8846.

**Oct. 24 & Nov. 7** — Cal Sailing Club's free introductory sail at Berkeley Marina, 1-4 p.m. Info, [www.cal-sailing.org](http://www.cal-sailing.org).

**Oct. 24** — Ha-Ha Halloween Costume Party & BBQ in San Diego West Marine parking lot. May the best pirate win!

**Oct. 25** — Baja Ha-Ha XVII Cruisers Rally starts from San Diego! Info, [www.baja-haha.com](http://www.baja-haha.com).

**Oct. 30** — SF Maritime Park's Sea Music Concert Series aboard *Balclutha* at Hyde St. Pier, 8-10 p.m. Featuring Lee Murdock. \$14. Info, (415) 447-5000 or [www.nps.gov/safr](http://www.nps.gov/safr).

**Oct. 30-31** — Gear & Boat Sale benefitting Richmond YC Foundation, 9 a.m. till dark. Lots of nautical gear and boats at bargain prices! Info, [www.richmondyc.org](http://www.richmondyc.org) then click the 'RYC Foundation' tab.

**Oct. 31, 1984** — The tanker *Puerto Rican* exploded in the Gulf of the Farallones, spilling 1.47 million gallons of oil. It sank with 365,500 gallons of bunker fuel aboard, and reportedly leaked for several years.

**Oct. 31** — Dress as your favorite sailor for Halloween.

**October, 1980** — It Was Thirty Years Ago, from a *Letter* by Sally Green:

Thought you might enjoy this article, written by a reporter who happened to be jogging on "lonely and windswept Ninini

# 43' Shannon Ketch

*Our Boat of the Month*

*s/v Celebration*



**For a detailed specifications sheet on this vessel or for any of our Exclusive Listings, please call Ed McGrath at (925) 209-7813 or email him at: [ed@mcgrathyachts.com](mailto:ed@mcgrathyachts.com)**



**McGrath Yachts**  
1070 Marina Village Parkway #106, Alameda, CA 94501  
(510) 521-5020 • [www.mcgrathyachts.com](http://www.mcgrathyachts.com)

# STEP ABOARD

at our dock

# SC<sup>37</sup>

Santa Cruz  
YACHTS



Fast Is Fun!

## SCORCHING SPEED! Plus:

Easier to sail, easier to manage.

Efficient design means smaller offshore crews to Mexico or Hawaii. Try it.

Call for a test sail... and hold on tight!



J/111

If you love to go sailing, you'll love this new 36-ft speedster. She's a pleasure daysailing, weekendng, or racing.



Summit 35

An already successful, just launched, dual-purpose IRC cruiser-racer, and all-around performer.

# SAIL

California

Alameda  
(510) 523-8500  
norman@sailcal.com  
steve@sailcal.com

www.sailcal.com • www.santacruzayachts.com

## CALENDAR

Point" and ran into three BYC women standing watch on the finishing line for the San Francisco to Kauai TransPac:

*I fell in with a band of yachties the other day.*

*They're different from the rest of us. I could tell that almost at once.*

*They live differently. They talk a different language. They approach things in a different manner.*

*Take this: The yachties were involved in one of the recent San Francisco to Kauai yacht races — as officials rather than entrants. This particular group of yachties had rented one of those little campers that sits on top of a small Japanese pickup truck.*

*Anyone else would feel cramped and uncomfortable inside. Not the yachties.*

*"It's just a Cal 20 with headroom," they said. A Cal 20 is a sailboat 20 feet long and not very wide at all. A Cal 20 with headroom, well, they made that sound plush.*

*I learned that there is a great schism among sailboaters. There are cruisers — people who like to go on long, leisurely voyages — and there are racers — people who continually threaten themselves with ulcers by screaming at each other to make boats go faster, and who argue at great length the things that potentially speed up a boat.*

*Most of the members of my band of yachties were racers. I compared them to a couple of cruisers not in the group.*

*The racers walk like cats on the prowl, looking for something to attack. I suppose they look for unhaunched downhauls, dropped topping lifts or loose running backstays, and plan to pounce without a second thought.*

*There's a practical glimmer in the eyes of the racers. They're intense and given to quick, granite-firm opinions.*

*Cruisers, on the other hand, or at least the ones I checked out, seem absolutely at one with the world. They wander about looking something between smug and dreamily content. Where a racer will stick fast to an opinion, a cruiser sometimes will argue both sides of the issue for you, and then tell you it doesn't really matter which is right.*

*There's something in common, though, between racer and cruiser. They know how to party.*

*P.S.: Since the race, this guy has bought his own boat. Obviously we ruined the lad!*

**Nov. 4** — 'Five Things You Should Know About Radar' by Richard Foregger of Club Nautique at San Carlos West Marine, 6-8 p.m. Free. Info, (650) 593-2070.

**Nov. 6** — Cruisers' Kick-Off Potluck at Downwind Marine in San Diego, 12-4 p.m. Info, [www.downwindmarine.com](http://www.downwindmarine.com).

### Racing

**Oct. 1-2** — 47th Annual San Diego to Ensenada Yacht Race. Southwestern YC, [www.southwesternyc.org](http://www.southwesternyc.org).

**Oct. 1-3** — Moore 24 Nationals in Santa Cruz. SCYC, [www.scyc.org](http://www.scyc.org).

**Oct. 2** — 30th Annual Women Skippers Regatta to benefit youth sailing. SYC, [www.sausalitoyachtclub.org](http://www.sausalitoyachtclub.org) or (415) 381-5475.

**Oct. 2** — Islander 36 Nationals hosted by GGYC. Info, [www.islander36.org/10race.html](http://www.islander36.org/10race.html).

**Oct. 2** — Around the Brothers Race. RYC, [www.richmondyc.org](http://www.richmondyc.org).

**Oct. 2** — Benicia YC Regatta. BenYC, [www.beniciayachtclub.com](http://www.beniciayachtclub.com).

**Oct. 2** — Fall Series #2. SSC, [www.stocktonssc.org](http://www.stocktonssc.org).

**Oct. 2-3** — Leukemia Cup Regatta, PHRF and one-design racing to benefit the Leukemia and Lymphoma Society.



# SAIL *California*

## YOUR PERFORMANCE YACHT SPECIALISTS

### ALAMEDA

1070 Marina Village Pkwy #108  
Alameda, CA 94501  
**(510) 523-8500**  
FAX (510) 522-0641

### SEATTLE

**SAIL NORTHWEST**  
7001 Seaview Ave. NW #140  
Seattle, WA 98117  
**(206) 286-1004**



sistership

**53' J/160, 2000, Novakane**  
Sailing World Boat of the Year.  
Asking **\$619,000**



**Santa Cruz 52, 1998, Hula**  
Deep draft for cruising, buoy and offshore.  
This boat has it all. Reduced to **\$495,000**



**J/122, TKO**  
Ready to win the Big Boat Series again!  
Asking **\$429,000**

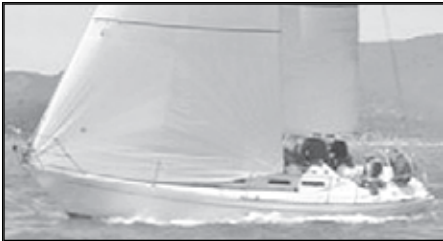

**Islander 36, 1972, Absolute**  
Best in fleet.  
Asking **\$45,000**



**Kernan 44, Wasabi**  
Turn key race winner.  
Asking **\$429,000**



**39' Schumacher, 1996, Recidivist**  
Well equipped, proven race winner.  
Asking **\$129,000**



**J/32, 2002, Tango**  
Well maintained and equipped.  
Asking **\$119,000**



**J/105s**  
We have seven from  
**\$75,000**



**40' Summit, 2008, Soozal**  
IRC super boat.  
Call for details.



**Custom Wylie 42, 1991, Scorpio**  
Proven winner, race ready.  
Asking **\$169,000**

77' Andrews, '03*.....	\$799,000	40' J/122, '07, TKO.....	Reduced \$429,000	35' 1D35, '00, Sweet Sensation.....	\$69,000
53' J/160, '00, Novakane.....	\$619,000	40' Summit, '08, Soozal.....	New Listing	34' J/34, '85, The Zoo*.....	\$29,900
52' Santa Cruz, '00, Isis.....	\$520,000	40' Avance, '85, Caribou*.....	\$119,000	34' MJM 34z, '05*.....	\$365,000
52' Santa Cruz, '99, Renegade.....	\$595,000	39' Schumacher, '96, Recidivist.....	\$129,000	34' Olson-Ericson, '89*.....	SOLD
52' Santa Cruz, '98, Hula.....	\$495,000	36' J/109, '03*.....	\$189,000	33' J/100, Hull #9, '05.....	\$106,000
52' TransPac with IRC mods, '03, Braveheart*.....	\$499,000	36' Islander 36, '72, Absolute.....	\$45,000	32' J/32, '02, Tango.....	\$119,000
48' J/145, Hull #9, '03*.....	\$675,000	35' J/105, '92, Hull #44, Orion.....	\$75,000	32' Catalina 320*.....	\$61,000
48' 1D48, '96, Cal Maritime.....	Pending \$99,000	35' J/105, '99, Life Is Good*.....	\$83,000	30' Knarr, '80.....	\$30,000
47' Valiant, '81, Sunchase.....	\$125,000	35' J/105, '00, Hull #347, Bald Eagle.....	\$109,000	29' MJM 29z, '07*.....	\$269,000
44' Kernan, Wasabi.....	\$429,000	35' J/105, '00, Hull #343, Nirvana.....	\$109,000	28' Alerion Express, '06*.....	\$99,000
44' J/44, '93, Halcyon Days*.....	\$285,000	35' J/105, '01, Hull #469, Streaker.....	\$115,000	26' J/80, '04, Heart Attack.....	New Listing \$34,900
42' Custom Wylie, Scorpio.....	\$169,000	35' J/105, '04, Hull #634, Flying Dutchman.....	\$124,900	26' Aquapro Raider, '02.....	\$59,000
41' J/124, '07, Fortuna.....	SOLD	35' J/35, '84, The Boss*.....	\$39,900		

\* Denotes Seattle Boats

# SAIL *California*

www.sailcal.com

email: norman@sailcal.com, steve@sailcal.com

DEALERS FOR THESE FINE YACHTS:

*Santa Cruz*  
— YACHTS —

*SUMMIT*  
YACHTS

**J.**  
BOATS

# CALENDAR

Hosted by SFYC, featuring keynote speaker Russell Coutts of America's Cup fame. Info, [www.leukemicup.org/sf](http://www.leukemicup.org/sf).

**Oct. 3** — El Toro Stampede. RYC, [www.eltoroyra.org](http://www.eltoroyra.org).

**Oct. 3** — YRA-OYRA Jr. Waterhouse. RYC, [www.yra.org](http://www.yra.org).

**Oct. 3** — Berkeley YC Chowder Series begins and continues every Sunday through March, except on Berkeley Midwinter weekends. BYC, [www.berkeleyyc.org](http://www.berkeleyyc.org).

**Oct. 9** — El Toro Corkscrew Slough Regatta. SeqYC, [www.eltoro.org](http://www.eltoro.org).

**Oct. 9-10** — Belvedere Cup, J/105 match racing. SFYC, [www.sfyf.org](http://www.sfyf.org).

**Oct. 15-17** — Wylie Wabbit Nationals. StFYC, [www.stfyf.com](http://www.stfyf.com).

**Oct. 16** — YRA-HDA Yankee Cup & YRA-ODCA Champion of Champions. IYC, [www.yra.org](http://www.yra.org).

**Oct. 16** — Fall Series #3. FLYC, [www.flyc.org](http://www.flyc.org).

**Oct. 16** — South Bay Championship. SeqYC, [www.sequoiayc.org](http://www.sequoiayc.org).

**Oct. 16** — Twin Island #3. SYC, [www.syc.org](http://www.syc.org).

**Oct. 16** — Doublehanded Race. TYC, [www.tyc.org](http://www.tyc.org).

**Oct. 16** — Oktoberfest Regatta, a pursuit race around Alcatraz for PHRF boats or a fun cruiser rally around TI. RYC, [www.richmondyc.org](http://www.richmondyc.org).

**Oct. 16-17** — SSS Vallejo 1-2, a mellow way to end the shorthanded season. Info, [www.sfbaysss.org](http://www.sfbaysss.org).

**Oct. 16-17** — Jessica Cup, fleet racing for big woodies. StFYC, [www.stfyf.com](http://www.stfyf.com).

**Oct. 16-17** — Joe Logan (Mercuries), Calvin Paige (Stars), and Albert T. Simpson (sportboat) Regattas. StFYC, [www.stfyf.com](http://www.stfyf.com).

**Oct. 17** — Lady Skippers Race. PresYC, [www.presidioyachtclub.org](http://www.presidioyachtclub.org).

**Oct. 17** — Singlehanded Race. TYC, [www.tyc.org](http://www.tyc.org).

**Oct. 23** — Ruth Gordon Schnapp Regatta, a fundraiser for Susan G. Komen for the Cure. Requires a woman to be at the helm. GGYC, [www.ggyc.com](http://www.ggyc.com).

**Oct. 23-24** — Fall Dinghy & Olympic Classes. StFYC, [www.stfyf.com](http://www.stfyf.com).

**Oct. 24** — Round the Island Race. SFYC, [www.sfyf.org](http://www.sfyf.org).

**Oct. 30** — Fall Series #4. FLYC, [www.flyc.org](http://www.flyc.org).

**Oct. 30** — Red Rock Race. TYC, [www.tyc.org](http://www.tyc.org).

**Oct. 30-31** — Team Race Championships. StFYC, [www.stfyf.com](http://www.stfyf.com).

**Oct. 30-31** — Great Pumpkin Regatta, a Halloween tradition. This year's theme is 'Rocky Horror Regatta!' RYC, [www.richmondyc.org](http://www.richmondyc.org).

**Oct. 30-Nov. 6** — 24th Annual Pro Am Regatta on Virgin Gorda, hosted by Bitter End YC. Info, [www.beyc.com](http://www.beyc.com).

**Nov. 6** — Summer's Last Gasp Race. HMBYC, [www.hmbyc.org](http://www.hmbyc.org).

**Nov. 6** — Midwinter #1 (Seaweed Soup Regatta). GGYC, [www.ggyc.org](http://www.ggyc.org).

**Nov. 6-7** — Match Race Champs. StFYC, [www.stfyf.com](http://www.stfyf.com).

**Nov. 6-7** — Monterey Invitational/Perry Cup #1 (Mercuries). MPYC, [www.mpyc.org](http://www.mpyc.org).

**Nov. 7** — Jack & Jill + 1, the woman-skippered triplehanded race on the Estuary. IYC, [www.iyc.org](http://www.iyc.org).

**Nov. 7** — Midwinter #1. SYC, [www.sausalitoyachtclub.org](http://www.sausalitoyachtclub.org).

**Nov. 7**, Redwood Cup #1. SeqYC, [www.sequoiayc.org](http://www.sequoiayc.org).

**Nov. 16** — YRA Year-Ends Awards Party, location TBA. Info, (415) 771-9500 or [www.yra.org](http://www.yra.org).

**Nov. 16** — The Big Sail: Stanford vs. Cal in J/105s. More fun than football! StFYC, [www.stfyf.com](http://www.stfyf.com).



## ULTRAFFEE® LS-1 & LSZ-1

The Ultrafeed® is a portable, cast iron power-house sewing machine with mechanical walking foot and Post-Pin clutching system. Try the LS-1 for straight stitch sewing or the LSZ-1 for zigzag and straight stitch sewing. Experience the superior performance and versatility of an Ultrafeed® today.



**VISIT US**  
Annapolis Boat Show  
October 7 - 11, 2010 / Tent H: 25, 26, 27

Free Catalog / 800.348.2769  
[www.sailrite.com](http://www.sailrite.com)

# NOT JUST GREAT SAILS, BUT WORLD CLASS SAILMAKERS!

**REPAIR, RECUT,  
UPGRADE...**

*Quantum does it!*

**Sail Repair:** From simple tears to extreme reconstruction  
**Re-Cuts:** Make your old sails work again  
**Conversions:** UV covers, roller furling, Dutchman, and more  
**Storage:** Low winter rates on sail storage  
**Same day, overnight service, removal, installation, and drop off and pick up service available!**



**Quantum Pacific**  
1230 Brickyard Cove Rd. Suite 200  
Point Richmond, CA 94801  
(510) 234-4334  
[dteakell@quantumsails.com](mailto:dteakell@quantumsails.com)  
[jthorpe@quantumsails.com](mailto:jthorpe@quantumsails.com)

# HAS CHRISTMAS COME EARLY?

Quality, strength **and** reliability, all wrapped up in over 35 years' experience. What more could you ask for!

At Sta-Lok we know what goes into producing top quality stainless steel rigging hardware. We also know that change is hard but we think you deserve the best. So go on, treat yourself!

**Make the change  
Make it...**

**STA-LOK®**

(Can't wait 'til Christmas? Then take a sneak peek at the Annapolis Sailboat Show, Booth YB16. See you there!)

**Sta-Lok Terminals Inc.**

(910) 399-5206

[www.stalokinc.com](http://www.stalokinc.com) [info@stalokinc.com](mailto:info@stalokinc.com)

2725-1B Old Wrightsboro Road, Wilmington, NC 28405



## SAUSALITO

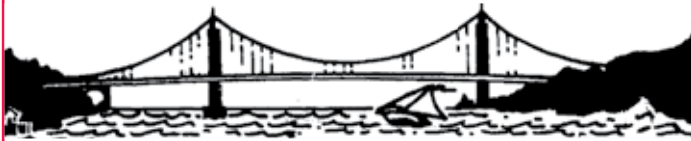

# LIST MARINE INC.

- Full service engine shop
- We service all makes
- Dockside facilities
- Mobile service trucks

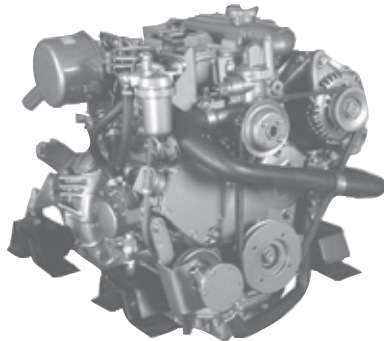

**YANMAR**  
marine 

P.O. BOX 2008 / 69 LIBERTY SHIP WAY • SAUSALITO, CA 94966  
Adjacent to Schoonmaker Pt. Marina

**415•332•5478**

[www.listmarine.com](http://www.listmarine.com)

# CALENDAR

## Remaining Summer Beer Can Regattas

**CAL SAILING CLUB** — Year-round Sunday morning dinghy races, intraclub only, typically in Laser Bahias and JY15s. Email Gary and Alistair at [racing\\_chair@cal-sailing.org](mailto:racing_chair@cal-sailing.org).

**COYOTE POINT YC** — Every Wednesday night through 10/27. Torin Knorr, (650) 863-2570 or [regatta@cpyc.com](mailto:regatta@cpyc.com).

**LAKE TAHOE WINDJAMMERS YC** — Every Wednesday night through 10/13. Pete Russell, (775) 721-0499.

**SANTA CRUZ YC** — Wet Wednesdays through 11/3. Greg Haws, (831) 425-0690 or [greg@scyc.org](mailto:greg@scyc.org).

**SEQUOIA YC** — Every Wednesday night through 10/13. Steve Holmstrom, (650) 400-8584 or [steve@toothwet.info](mailto:steve@toothwet.info).

**SHORELINE LAKE AQUATIC CENTER** — Catalina 14.2s every Thurs. night till 11/7. Lasers every Weds. night through October. John Stedman, (650) 940-9948 or (650) 965-7474.

Please send your calendar items by the 10th of the month to [calendar@latitude38.com](mailto:calendar@latitude38.com). If you're totally old-school, mail them to *Latitude 38* (Attn: Calendar), 15 Locust Avenue, Mill Valley, CA, 94941 or fax them to us at (415) 383-5816. But please, no phone-ins! Calendar listings are for marine-related events that either are free or don't cost much to attend. The Calendar is not meant to support commercial enterprises.

## October Weekend Tides

date/day	time/ht. LOW	time/ht. HIGH	time/ht. LOW	time/ht. HIGH
10/02Sat	0103/0.2	0837/4.6	1323/2.9	1913/5.5
10/03Sun	0202/0.1	0917/5.0	1426/2.3	2024/5.6
	<b>HIGH</b>	<b>LOW</b>	<b>HIGH</b>	<b>LOW</b>
10/09Sat	0125/5.4	0631/1.8	1253/6.6	1923/-0.9
10/10Sun	0224/5.1	0717/2.2	1334/6.5	2014/-0.8
	<b>LOW</b>	<b>HIGH</b>	<b>LOW</b>	<b>HIGH</b>
10/16Sat	0118/0.6	0841/4.9	1405/2.5	1938/4.8
10/17Sun	0210/0.8	0917/5.0	1456/2.1	2042/4.7
	<b>HIGH</b>	<b>LOW</b>	<b>HIGH</b>	<b>LOW</b>
10/23Sat	0046/4.7	0540/2.3	1152/5.9	1828/-0.2
10/24Sun	0131/4.6	0613/2.5	1222/5.9	1904/-0.3
10/30Sat	0703/4.8	1203/3.0	1739/5.1	
	<b>LOW</b>	<b>HIGH</b>	<b>LOW</b>	<b>HIGH</b>
10/31Sun	0023/0.2	0748/5.1	1317/2.4	1900/4.9

## October Weekend Currents

date/day	slack	max	slack	max
10/02Sat	0322	0627/2.9F	0953	1204/1.9E
	1530	1815/2.0F	2102	
10/03Sun		0020/4.0E	0420	0725/3.2F
	1042	1306/2.5E	1636	1923/2.5F
	2215			
10/09Sat	0315	0541/3.4E	0859	1149/3.4F
	1440	1754/5.4E	2144	
10/10Sun		0047/4.3F	0410	0630/2.9E
	0944	1234/3.0F	1522	1841/5.2E
	2237			
10/16Sat	0335	0653/2.8F	0952	1249/1.8E
	1602	1850/1.8F	2121	
10/17Sun		0030/3.0E	0427	0742/2.8F
	1036	1338/2.2E	1656	1949/2.1F
	2224			
10/23Sat	0231	0451/2.6E	0809	1058/2.6F
	1346	1701/4.4E	2053	2351/3.4F
10/24Sun	0315	0531/2.4E	0839	1133/2.5F
	1417	1741/4.6E	2131	
10/30Sat	0145	0453/3.1F	0825	1040/2.1E
	1410	1649/1.9F	1931	2251/3.8E
10/31Sun	0244	0551/3.2F	0914	1142/2.6E
	1522	1801/2.2F	2051	2354/3.7E

# THE BOAT YARD AT GRAND MARINA

"Where Service Has Meaning"

**Interlux**  
yachtpaint.com

**AWLGRIP**

**60-TON  
TRAVELIFT**



FEATURING  
TRINIDAD  
ANTI-FOULING PAINT BY  
**PETTIT**  
Go clean into the future.  
RATED "SUPERIOR" by  
Practical Sailor

Official  
Sponsor  
2010  
BAJA  
HA-HA

*The only yard to brush  
on your bottom paint!*

Dealers for:

**MAX-PROP**  
AUTOMATIC FEATHERING PROPELLERS

**GORI**  
marine

**Webasto**

PACKLESS SEALING SYSTEM  
**SHAFT SEAL**

**Lectra/San**

**SIDE-POWER**  
Thruster systems

**facnor**  
FURLING SYSTEMS INC.

**AQUAMARINE**  
FINE REVERSE OSMOSIS EQUIPMENT

## IT'S SIMPLE!

Call The Boat Yard at Grand Marina for the Lowest Bottom Prices!

~ COMPARE US WITH THE COMPETITION ~

- Prop and Shaft Work
- Mast & Rigging Repair
- Fiberglass & Blister Repair
- Gelcoat Repair
- Gas & Diesel Engine Service
- LPU Hull & Topside
- Electrical Repair & Installation

**CALL FOR A RESERVATION**

(510) 521-6100 • Fax (510) 521-3684

Located at Grand Marina • 2021 Alaska Packer Place, Alameda

[www.boatyardgm.com](http://www.boatyardgm.com)

# SCHOON- MAKER POINT MARI-



**160-Berth Marina in one of the most beautiful spots on the Bay**



- Visitor berths • Guest moorage up to 220 ft.
- 35-ft to 75-ft slips • Pumpouts • Marine services
- Dry Storage Available • Three-ton hoist
- Restaurant • Beach • Rowing • Kayaking

## Sausalito's Finest Marina

85 LIBERTY SHIP WAY, #205  
SAUSALITO, CA 94965

**415-331-5550**

**FAX 415-331-8523**

[www.schoonmakermarina.com](http://www.schoonmakermarina.com)

## LETTERS

### ↑↓ HE WORKED 12 HOURS A DAY, SEVEN DAYS A WEEK

I'm at home in St. Thomas, U.S. Virgins, sitting on the boat my husband built, waiting for Hurricane *Earl* to move along. I read *Latitude's* response to Eric and Jeanna Brown's letter about their desire to complete a Freya 39 from a bare hull. "Don't do it!" was my husband's first utterance.

But he loves the boat he built for us. One time I asked him what boat he would want if he won the lottery. "This one," he



COURTESY JEAN

'Jean' anchored off Lameshur Bay on St. John.

said. In fact, I wrote to *Latitude* back in April '00 asking for information about Ham radios, and mentioned we were building a boat and would move onto her in the summer. We missed that goal by a couple of months, but have been living on her since launching in October '00.

I'm writing because we have a suggestion for home builders — don't work at another job during the first six months of building your own boat. The idea is that it helps to get off to a good start. We were in one of our transition modes, so it was easier for us to adhere to the suggestion than it might be for others.

When we finally got back the Virgins with our new boat, after a successful sail from Galveston Bay, we visited friends at Gold Coast Yachts in St. Croix, where my husband had worked on and off since their beginning. Roger Hatfield, one of the founders, said an individual builder really has to finish a boat in three to four years or some 'life event' will intervene and the boat won't get finished. Our boat is simple, but nonetheless took about two years to build. My husband worked 12 hours a day, seven days a week for about three-quarters of that time.

*Latitude's* response really said it all. You have to have a passion like Rick Gio's in order to build your own boat. And you have to accept that building a boat yourself won't be any less expensive than buying a new one. In our case, building a boat was something my husband always wanted to do. He'd shaped surfboards and built little speedboats as a kid, and went to wooden boat building school. He has always been boat crazy, so he definitely had the passion necessary. And if you build your own boat, once you are finished, you are free to go wherever you wish.

Paula Ferguson  
Jean, Adams 13 meter  
St. Thomas, VI

### ↑↓ DITCH THE DIESEL!

I'll probably be pissing in the wind with my comment on the topic of 'removing a diesel in favor of an outboard', but here goes. The modern four-stroke, five-star outboards have the following advantages over diesels:

- They are quieter, as they have no hull vibration or diesel noise.
- They are more fuel efficient, as they use fewer gallons per hour at the lower throttle setting.
- They are easier to service, as you get no grease in the bilge.
- They maneuver better, as they are mounted on the transom.

# Birds Aren't The Only Ones Who Fly South For The Winter...



Let Svendsen's help you prepare for your voyage. Our store and full-service repair facilities are staffed by accomplished sailors and power boaters who have intimate, first-hand knowledge of your boating needs. Our expertise is your expertise – come see us today!

***Svendsen's. For All Real World Adventurers.***



**ENGINE  
SERVICE  
SPECIAL**

### **Inboards/Outboards**

**Only \$500\***

Drive Service • Replace Zincs  
Change Oil & Filter  
Engine Safety Inspection

*Mention code IO1010 to redeem*

*Specials end October 31, 2010. May not be combined with other offers.*

### **Sailboats**

**Only \$250\***

Change Oil & Filter  
Belt Adjustment  
Engine Safety Inspection

*Mention code SB1010 to redeem*



**SVENDSEN'S**

**Boat Works:** 510.522.2886 or [svendsens.com](http://svendsens.com)

**Chandlery:** 510.521.8454 or [svendsensmarine.com](http://svendsensmarine.com)

**Conveniently Located in the Alameda Marina at 1851 Clement Avenue**

# CRUISERS!

## Head for Downwind Marine!

Official  
Sponsor  
2010  
BAJA  
HA-HA

**SPECIAL CRUISER SEMINARS — \$3/person**  
7:30PM at Downwind Marine — Doors open at 7:15PM

- Mon 10/18 **Sailing Downwind with the Proper Gear and Technique** — Bruce Brown, Forespar & Hayn Marine
- Tues 10/19 **Cruising Mexico and PV Puddle Jump Seminar Preview** — Dick Markie, Dockmaster, Paradise Village Marina, PV
- Wed 10/20 **Outboard Motor Needs for Cruising in Mexico** — Tom Teevin, Aquarius Yacht Services/Veteran Cruiser
- Thurs 10/21 **AIS: The Best Collision Avoidance System** — Steven Gloor, GTS Consulting/Veteran Cruiser
- Fri 10/22 **Cruising the Sea of Cortez & West Coast Mexico** — Shawn Breeding & Heather Bansmer, Cruising Guide Authors
- Tues 10/26 **Staying Friends with Your Diesel Engine** — CF Koehler, Koehler Kraft/Veteran Cruiser
- Wed 10/27 **Solar Powered Battery Charging & Battery Systems** — Rick Cullen, President, Blue Sky Energy Systems, Inc.
- Thurs 10/28 **Cruising on 12 Volt Batteries, Alternators, Invertors: Tips and Troubleshooting** — Barry Kessler, Xantrex Repair Tech/CEO, Altra Regulators
- Fri 10/29 **Cruising the Sea of Cortez & West Coast Mexico** — Shawn Breeding & Heather Bansmer, Cruising Guide Authors
- Tues 11/2 **AIS: The Best Collision Avoidance System** — Steven Gloor, GTS Consulting/Veteran Cruiser
- Wed 11/3 **Intro to Offshore Communications for Cruisers** — Shea Weston, Offshore Outfitters
- Thur 11/4 **Outfitting for Safety at Sea & Life Raft Deployment Demo** — Bruce Brown, Rep for Switlik & SeaPac
- Tues 11/9 **Surviving a Haul-Out** — C.F. Koehler, Koehler Kraft/Veteran Cruiser
- Wed 11/10 **Intro to Offshore Communications for Cruisers** — Shea Weston, Offshore Outfitters
- Thurs 11/11 To Be Announced

### SPECIAL EVENTS

- Sat 10/16 **Baja Ha-Ha Welcome Potluck at Downwind Marine**  
Noon-4PM at our store, 2804 Cañon Street, San Diego  
Hot dogs & sodas for ALL customers plus potluck for Ha-Ha cruisers.  
8:30AM-5:00PM. One-day only discount prices for all during store hours. Product Reps on hand. See [www.downwindmarine.com](http://www.downwindmarine.com).
- Oct 18-22 **Downwind Morning Buddy Boat Meetings — ALL WEEK**  
10:00AM — Meet at Downwind Marine for coffee and donuts
- Tues 10/19 **SailMail Marine Communications Seminar**  
8:30AM-4:00PM. Join Jim & Sue Corenman and Shea Weston for a full one-day intensive training on Internet Email Service for Cruisers.  
\$50/person or \$75/couple — includes lunch!  
Point Loma Assembly Hall, 3035 Talbot Street, San Diego
- Sat 11/6 **Annual Downwind Cruisers' Kick-Off Potluck BBQ**  
Noon-4:00PM at our store, 2804 Cañon Street, San Diego. We bring sodas, burgers & hot dogs; cruisers bring salad, side dish or dessert to share. 8:30AM-5:00PM. Special Gifts for purchases over \$250!  
Product Reps on hand. See [www.downwindmarine.com](http://www.downwindmarine.com).

[www.downwindmarine.com](http://www.downwindmarine.com)

San Diego Marine Exchange



THE CRUISER'S CHANDLERY

2804 Cañon Street  
San Diego, CA 92106  
Phone: (619) 224-2733  
Toll-Free: (866) 289-0242  
Fax: (619) 224-7683  
info@downwindmarine.com

CRUISERS' NET, Ch. 68, from 8:30 am weekdays: WHX369

## LETTERS

- They are true marine engines.

If anyone doesn't believe me, we should have a contest. We each get five gallons of fuel, and we see who can get the far-



LATITUDE / RICHARD

**While not perfect, transom-hung outboards can be a 'big bang for the buck' semi-solution.**

thest. The 4-hp engine on my 27-ft boat will do four knots at 1,000 rpm while burning .2 gallons per hour motor-ing on a calm ocean. That works out to about 20 mpg. Even at half that in a head-

wind, I'm doing better than a diesel. And if the wind is blowing, I'm sailing. 'Ditch the diesel!' is what I say.

As for finishing a boat from a bare hull, *Latitude* is absolutely right that there isn't much of a saving in money. But you do get the boat the way you want it. I've built at least three of these boats myself — and eliminated the diesel each time. You can see the last boat I built at [www.jeanmondeau.blogspot.com](http://www.jeanmondeau.blogspot.com).

Yes, I became as focused as Rick Gio was. As soon as I got home after work at 5:30 p.m., I changed into my work clothes and didn't step off the boat before 10 p.m. And I didn't spend any time dreaming or drinking. On weekends I put in 20-hour days. I completed the boat in three months, taking seven weeks on the interior. It was, of course, a much smaller boat.

My best piece of advice is to have the boat trucked to your home and build her in the backyard — as I did. You'll save an astronomical amount of time and money. Plus it will save your marriage. By the way, my marriage is doing fine. In fact, my wife was the taskmaster, as this was her boat project. I let her talk me into it!

With regard to marine heads, I always swim upstream.

P.S. *Latitude* is the greatest magazine going!

Jean & Denise Mondeau  
Carmela, '75 Cal 2-27  
Madera

*Jean — Thank you for the very kind words.*

*According to experts, diesel engines are about 45% energy efficient, while gas engines are only 30% energy efficient. Diesel fuel also has 10 to 20% more energy per unit volume than does gasoline.*

*Wikipedia reports that an efficient turbo diesel gets 40% more miles per gallon than does a gas engine, even though a diesel engine is heavier. They cite the example of current model Skoda Octavias — whatever they are — using Volkswagen engines. The gas version gets 38.2 mpg, while the slightly more powerful diesel version gets 53.3 mpg. Indeed, 10 years ago Volkswagen was selling production model Lupos and Audi A-2s that got 74 mpg. No gas engine car has come anywhere close to that.*

*We suppose you'd have a chance of winning your bet because not many, if any, sailboats are equipped with 4-hp diesels. Nonetheless, small diesels, such as 12-hp models, merely sip fuel at low rpms, so we wouldn't recommend putting your pink slip up — or your taskmaster might have you working on yet another from-a-bare-hull job.*

*Your point that diesels are a little messier is well taken, and*





# THE DOYLE DIFFERENCE

Photography by Blake Jackson

Doyle Sailmakers has the right mix of performance, durability, value and service to earn your business. We understand that if a sail lasts twice as long, it costs you half as much. We won't over or under sell you. Our consultants will suggest a fair priced product, precisely tailored to your needs.

[www.doylesails.com](http://www.doylesails.com)  
[sanfrancisco@doylesails.com](mailto:sanfrancisco@doylesails.com)

BETTER ENGINEERED SAILS

**SLAM**



San Francisco  
Bill Colombo  
Dave Wilhite  
(510) 523-9411

# THE HEROIC TAILS OF ADVENTURE CAT!

PART IV

HAVE YOU BEEN SAILING WITH US YET? BE SURE TO JOIN US FOR A CRUISE THIS FALL BEFORE I TAKE MY CAT NAP FOR THE WINTER SEASON!



FALL IS BEAUTIFUL WEATHER FOR SAILING. OUR CRUISES ARE A FUN, AFFORDABLE WAY TO GET AN UP-CLOSE LOOK AT THE GOLDEN GATE BRIDGE, ALCATRAZ ISLAND, THE CITY SKYLINE AND THE ADORABLY LAZY SEA LIONS.

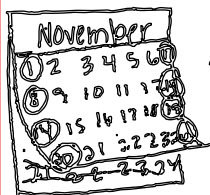
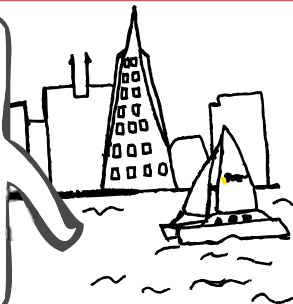

DURING OCTOBER, I TAKE PASSENGERS OUT FOR DAILY CRUISES AT 1:00PM, 3:00PM & 5:30PM AND IN NOVEMBER, WE SAIL ON WEEKENDS AT 1:00PM AND 4:00PM.



BOOK YOUR TICKETS SOON BEFORE WE "CAT NAP" FOR THE WINTER! CALL 1-800-498-4228 OR VISIT WWW.ADVENTURECAT.COM

## LETTERS

diesel doesn't smell so good either. But based on our experience with three outboard-powered sailboats — an Ericson 27, a Cal 25, and an Olson 30 — the outboards were awkward to use and didn't maneuver that well, particularly in reverse. Outboard-powered boats are also very poor performers in a sloppy sea, which you can often have when there is no wind. Lastly, experts will tell you that a well-cared-for diesel is much more reliable than a well-cared-for outboard, and diesels have much longer useful lifespans than do gas engines. Alas, diesels are considerably more expensive.

But it's a free world, so if you want to take an inboard diesel out of a sailboat and replace it with a gas outboard, that's your business. We'd just hesitate to recommend it to others.

By the way, anybody out there with a small boat and a small diesel willing to share information on their boat's fuel consumption in flat water?

### ↑↓ VINAIGRETTE FOR THE HEAD

When I retired in '97, I went to Florida and bought an old, but fine, Morgan Out Island 30 and moved aboard. She was the first boat I owned that was equipped with a working head. The boat's previous owner told me not to flush toilet paper down the head.

Shortly after buying the boat, and while she was still on the hard, I decided to check out all the plumbing and other systems that I figured would be hard to work on when she was back in the water. When I pulled the large gray ribbed hose that went from the toilet to the Electrosan. It was almost completely solid with calcium and other deposits. So I replaced all the flush-related plumbing and the toilet itself. Then I read everything I could about heads, what happens in them, and how to treat them.

For the next eight years, I flushed toilet paper and other flushable substances down the head. But at least once a week I treated the head with a 12-hour soaking of a half-cup of vinegar, and every three days I put in a tablespoon of vegetable oil, pumped a little, and left it in the system until the next morning.

I sold the boat eight years later, having never had a problem. I've talked to many cruisers about this subject, and most of them flush toilet paper down a well-cared-for head with no problem. Of course, if you use an old Montgomery Ward catalog for toilet paper, all bets are off.

Eldon McMullen  
ex-Slo-n-ezy, Morgan Out Island 30  
Planet Earth

Eldon — Some readers might think your vinegar and oil



LATITUDE / RICHARD

Salads are healthy for humans — and heads.

that doesn't happen, they should check with the next boatowner they see furiously beating a hose on the dock, as he's no doubt trying



# MODERN SAILING SCHOOL & CLUB

Sausalito, CA www.ModernSailing.com 800-995-1668

## Get your Coast Guard Captain's License.

Nov. 6 - Dec. 5  
work friendly schedule



**OUPV LICENSE**  
\$995

**100 TON LICENSE**  
\$1195

Our GUARANTEED, U.S. Coast Guard Approved course will prepare you for all elements of the exam, guide you through the application process, and conclude with on-site testing. Space is limited. Sign up today!

## Adventure Sailing with John Connolly



### GREECE & TURKEY

**LEG 1: April 20 - 30, 2011**  
(Skiathos - Lesvos)

**LEG 2: May 3 - 13, 2011**  
(Lesvos - Kos)

**Cost**  
\$2375 / berth  
\$4275 / cabin

**Obtain your ASA 106 Certification on either leg.**

### Spain / Morocco ONLY 2 SPOTS LEFT

**LEG 1: Oct. 30 - Nov. 11, 2010**  
(Mallorca-Gibraltar, via Spanish Coast)

**ASA 106**

**Cost**  
\$2475 / berth  
\$4450 / cabin



## Fall Dinner & Discussion Series at the Golden Gate Yacht Club



### Forecasting Marine Weather presented by NOAA

**Thursday, October 28 (6 - 9pm)**

Learn about weather patterns common to the central coast and their impact on the wind and waves. Explore the tools used to assess the current state of the ocean and atmosphere: satellite, RADAR and surface observations from buoy reports. And learn where to find these tools on the internet so you can make your own assessments.

**\$20 for members  
\$30 for non-members  
Must RSVP by  
calling (415) 331 - 8250.**

## Cooking at Sea Seminar

**Thursday, November 18 (6 - 9pm)**

Are you planning an overnight sailing trip? Wanna learn to make something other than sandwiches? Join us for this fun, tasty and educational seminar on cooking at sea! Topics covered will be provisioning for multiple day charters and recipe ideas. Dishes will be cooked on the spot with samples to taste!

## EMERGENCIES AT SEA with John Connolly

**West Marine, San Carlos**  
**Thursday, October 21 @ 6pm**

Join us at the Golden Gate Yacht Club as we discuss the 15 most common emergencies at sea and how to respond to them: demasting, engine failure, holes in the boat, crew overboard, etc.



## Upcoming Events

**October 2** - Docking Clinic (9am - 4pm)

**October 16** - Club Sail (10am - 4pm), BBQ @ 3:30pm

**October 17** - Refresher Course (9am - 4pm)

**October 21** - John Connolly's Emergencies at Sea @ West Marine, San Carlos

**October 23** - Full Moon Hike, Tennessee Valley (6 - 10pm) FREE!

**November 6** - Member Appreciation Day - BBQ and Charter Specials

## ASA OUTSTANDING SCHOOL 2009

# The Fix is In

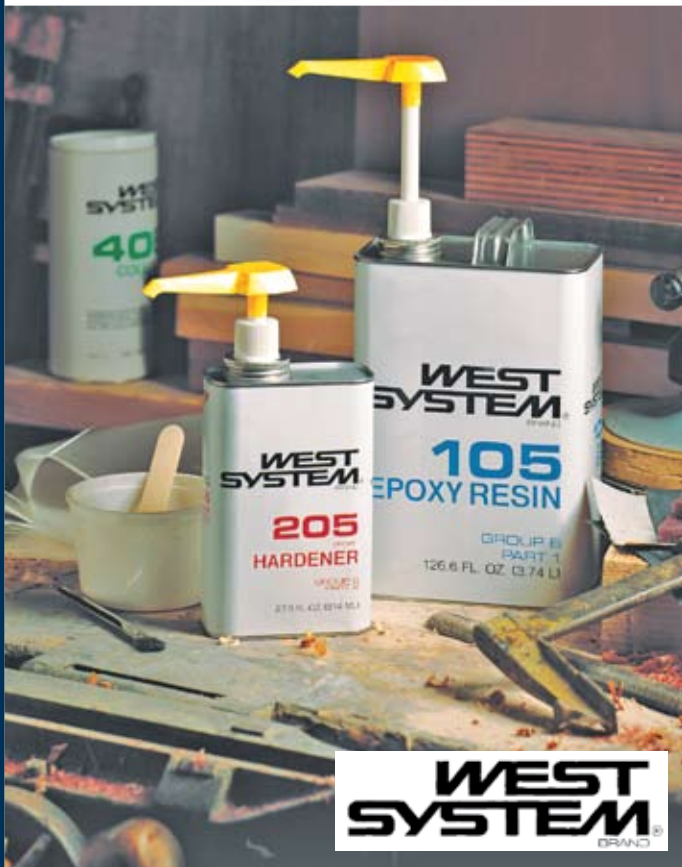

## West System® Brand Epoxy

For the almost limitless care and repair needs aboard a boat, the fix is in the can of WEST SYSTEM® Brand epoxy. Gluing, filling, coating, fairing—there's not much you can't do with this remarkable epoxy resin and the right filler(s). We've got the complete WEST SYSTEM Brand product line at West Marine. So the next time you need a fix, come on in!

**West Marine®**

Contact us for all of your Rigging Needs!  
**888-447-RIGG**

We have 17 stores in Northern California,  
 including our Alameda Sailing Superstore!  
 Visit [westmarine.com](http://westmarine.com) to find the store nearest you.

## LETTERS

to free such deposits from the hose. The oil is to keep all the rubber parts lubricated. In fact, some crews on charter boats in the Caribbean pump all the leftover salad and salad dressing down the heads to keep the soft parts in good working order.

It doesn't surprise us that someone who cleaned their hoses, treated their head and hoses with oil and vinegar, and pumped plenty of times, hasn't had any toilet problems. Most problems are caused by unknowing and/or uncaring guests who don't follow the rules. We once had an obviously disconnected head sitting on its side on Profligate, the seat heavily duct-taped shut, and a sign on it admonishing people not to use it. Despite all the implied and obvious imprecations, some numbskull ignored the sign, took the tape off, set it upright and pooped in it. You should have seen the crestfallen look on his face when he was told that he was going to have to clean it out.

### ↑↓ NO MORE THAN TWO 24-INCH LENGTHS

I'm up here in Ganges, British Columbia, on a powerboat charter with my parents and my daughter. We're celebrating the peeps' 66th anniversary — as in they've been married all that time! I saved the September *Latitude* to read on the trip, and I just got a bang out of the letter about marine heads and toilet paper.

I've been sailing since nobody knew what a holding tank was, and when the concept of them was finally explained, we all thought it was disgusting. Eew! Who would sail around with a tank full of poop? And we certainly wouldn't sail around with a bag full of nasty TP either! That's why God made fish! At Catalina, the opal eye — otherwise known as the 'poopy perch' — loved hanging around under the boats. Pumping the head was a sure way to create a mad feeding frenzy, much to the entertainment of my 10-year-old self! The poopy perch are hard to come by these days as everybody now has those dangled tanks. The fishing was a lot better back then, too.

Marine heads actually love TP in reasonable doses, and it's good for them as it helps clean out the hoses. The only time heads don't digest TP is when the hoses are constricted



LATITUDE / RICHARD

**Holly is cool with as much as two 24-inch lengths of toilet paper . . .**

by that nasty scaly stuff. This scuff builds up when people don't pump enough. I buy vast amounts of double-ply Costco TP for home and my Cal 40. None of that thin, scratchy stuff for me. As long as you don't put more than two 24-inch lengths of paper in per flush,

you're good to go. That includes your organic donation as well. If you need an additional wad of paper, flush the first batch first, then carry on as above.

When I used to skipper a big schooner for week-long charters, we — as many as 12 of us — all shared one head. Following the system described above, we didn't clog the head in 11 years. Sure, I had to explain how to use the head, which was always good for a few crude remarks and giggles, but we never had a problem. I'm sure glad we didn't sail around with all that used TP in bags. Besides, putting organic paper and poo in plastic bags is kind of silly if you think about it, as it can't decompose in landfill.

When we had our check-out session for the powerboat

California Certified  
Clean Marina

# BERKELEY MARINA



**Centrally located off Hwy. 80 at University Ave. • Fast Access to the Central Bay • Fuel Dock • Marine Center with 35 Ton Lift Capacity • Launch Ramp • Waterfront Hotel • Restaurants • Adventure Playground • 17 Acre Off-leash Dog Park • Picnic Sites • Deli and More...**



## Available Berths\*

84' Downwind Double, Live-aboard . . . . .	\$1,071.84/mo	50' Downwind Single, Live-aboard . . . . .	\$709.00/mo
65' Downwind Double, Live-aboard . . . . .	\$928.25/mo	48' Downwind Double, New Docks . . . . .	\$441.60/mo
65' Downwind Double . . . . .	\$783.25/mo	48' Downwind Double, New Docks . . . . .	\$441.60/mo
65' Crosswind Single, Live-aboard . . . . .	\$928.25/mo	41' Upwind Single . . . . .	\$472.32/mo
65' Crosswind Single . . . . .	\$783.25/mo	40' Downwind Double . . . . .	\$368.00/mo
60' Downwind Double . . . . .	\$621.00/mo	40' Downwind Double, Live-aboard . . . . .	\$513.00/mo
60' Upwind Single . . . . .	\$788.40/mo	36' Upwd 2-wide/Multihull, New Docks, Live-abd . .	\$832.47/mo
60' Downwind Double, New Docks . . . . .	\$585.00/mo	36' Upwind Double, New Docks . . . . .	\$343.73/mo
52' Upwind Double . . . . .	\$586.56/mo	36' Downwind 2-wide/Multihull, New Docks . . . . .	\$624.96/mo
52' Upwind Double . . . . .	\$586.56/mo	36' Downwind Double, New Docks . . . . .	\$312.48/mo
52' Upwind Double, Live-aboard . . . . .	\$731.56/mo	36' Upwind Double . . . . .	\$343.73/mo
50' Downwind Single . . . . .	\$564.00/mo	32' Downwind Double . . . . .	\$277.76/mo
50' Downwind Single . . . . .	\$564.00/mo	30' Upwind 2-wide/Multihull, New Docks . . . . .	\$572.88/mo

Berths subject to availability

\*all rental agreements & permits subject to approval of application and vessel inspection. Customer responsible for 1st month rent plus deposit, and all applicable fees.



**CITY OF BERKELEY**  
PARKS RECREATION AND WATERFRONT

**Berkeley Marina Office**  
**201 University Ave. • 510-981-6740**

Visit our website at: [www.ci.berkeley.ca.us/marina](http://www.ci.berkeley.ca.us/marina)

# Spin Doctor



## McLube Sailkote® Dry Lubricant

Every sailboat relies on gear that spins, or slides, or otherwise has to move to operate. And the easier those pieces of gear can move, the better they work. And the better *they* work, the less you and your crew have to work. So essentially what we have here is the classic "win-win situation". Which is why most sailboat racers, who care a lot about winning, use this stuff. Team McLube Sailkote® is remarkable in that it bonds to most any clean, dry surface and repels dirt, salt and grime that can gum up the works. It reduces friction and drag between surfaces in contact with air, water or other materials. The result is smoother operation of all the mechanical bits and pieces that you use for sail handling aboard. So give McLube Sailkote® a spin. You don't have to be a racer to be a winner!

Available in all West Marine stores in sizes from 6oz. to Gallons.

 **West Marine®**

We have 17 stores in Northern California, including our Alameda Sailing Superstore!

Visit [westmarine.com](http://westmarine.com) to find the store nearest you.

## LETTERS

we're on, we were told to not, under any circumstances, pump the holding tank overboard in U.S. waters. But we're in Canadian waters now, and they are fine with us dumping the tank — as long as we're in a deep-water area and not in a bay or a marina. Duh. The phrase the Canadians use is, "The solution to pollution is dilution." Be sure to pronounce it in Canadian, eh? I like how they think here.

Showering in the tropics? Sometimes a girl's gotta shower in private, but not always. It's kind of fun to wash outdoors. A few years ago, I got a delivery gig taking a good-sized cat from Florida to the Chesapeake. After a million breakdowns in 'the Ditch', we were finally able to go offshore and get into the Gulf Stream. One morning it was picture perfect out there, with no wind and flat, warm seas. As I had never swum in that particular piece of ocean, we stopped and went for a wash-



LATITUDE / RICHARD

... but the Costco economy pack would last 'One Square Sheryl' 41 years.

and-swim. One of my friends who came along wasn't a great swimmer, but she was up for the swim — as long as we didn't get too far away from the boat and had a line in the water. Once she was comfortable, we grabbed the soap and washed our hair and so forth. Smart ass that I am, I said, "Don't forget to wash your hoo." She replied by saying, "Give me your hand."(!) It turns out that she was drifting too far from the line in the water, was getting nervous, and wanted my hand to pull her closer to the line. We both almost drowned laughing, and still laugh about it years later.

I hope Anonymous gets over the 'camping' thing and realizes that there are as many ways to cruise as there are people doing it. Remember to 'think outside the box', sail with other people, and relax. It's really a lot of fun!

By the way, they don't just jump in the water and wash here in Canada — it's a bit nippy, eh!

Holly Scott  
Mahalo, Cal 40  
Alamitos Bay

*Holly — Don't let the popular and talented singer Sheryl 'Single Square' Crow hear you talk about 24-inch lengths of toilet paper. As she wrote in a message about environmentalism: "I propose a limitation be put on how many squares of toilet paper can be used during any one sitting." I think we Americans are an industrious enough people that we can make it work with only one square per restroom visit."*

*We don't know about the rest of you, but we think "industrious" is an unfortunate adjective to use when discussing using just one square of TP to clean up down there. A couple of uncouth sailors have suggested it might be why such a beautiful and talented woman as Crow is still single, but that's as disgusting as it is ridiculous.*

### ↑↓ ONLY IF IT PASSED THROUGH YOUR MOUTH FIRST

I've probably captained or crewed on at least 60 boats on short and long passages, taught on dozens more, and have owned several myself. Not on a single one of those boats was toilet paper ever allowed anywhere but in a little basket next to the head. And certainly never directly into the head itself.

# Rebuild vs. Repower What's right for you?

## Are you Happy With Your Present Boat?

Do you like its classic looks, strong construction and good sea keeping qualities? Chances are, you like everything about it... with one exception. Anyone who has ever owned a boat for more than a few years, will readily admit that there comes a point when the possibility of replacing an engine or two becomes a very real likelihood. To some, the mere thought of replacing their tired gas guzzling engines with a pair of new, fuel efficient diesels sounds great. To others, the task may appear somewhat daunting. After all, repowering any inboard is a little more involved than simply dropping a new outboard on your transom. In spite of its perceived complexity, repowering doesn't have to be a hassle.

## Engine Reliability is Paramount!

Engine selection is indeed important. Marine engines must, above all else, be reliable. Engine reliability is especially important in pleasure boats, where the capability of the crew to deal with mechanical problems may not equal that of crews on commercial vessels. Today's marine engines have a long life; however, eventually either major repairs or replacement may become necessary. That is the time to consider repowering.

## Cost vs. Value

It may be tempting to think that the value of a boat repowered with a new engine will increase enough to fully offset the cost of the new engine and its installation. Although the boat will be worth more with a new engine,

the increase in value in the used boat market may not equal your investment if you sell the boat. The same is generally true if you convert from gas to diesel. The boat's value will increase, but probably not enough to fully pay for the conversion. That said, you are considering the rebuild or repower because you want to use your boat, not sell it. And what is the value of having a reliable engine in your boat in terms of safety for your family?

## The Rebuild/Repower Trade-Off

Although rebuilding an existing engine normally poses few challenges, the installation of a new engine usually provides significant performance and economic advantages. Many parts and accessories of a rebuilt engine – alternator, starter, water pump, for example – are usually retained, and have an uncertain further life expectancy. All parts of a new power plant will be unused and the entire engine will carry a very valuable manufacturer's warranty. The new engine will be more reliable with state-of-the-art technology. In addition, new engines are typically more serviceable, provide superior performance, are cleaner running, and are much more fuel efficient. The reasons to repower far outweigh the excuses to rebuild.

## Repowering, Getting the Job Done Right

A successful repowering project involves two equally critical decisions; choosing the right engine for the boat and selecting a qualified installer. While engines can be precisely defined by their specifications, the installation of new engines requires reliance upon the engineering judgment and the skill of those doing the work. We can recommend an engine and refer you to a qualified Yanmar Dealer to perform the repower.

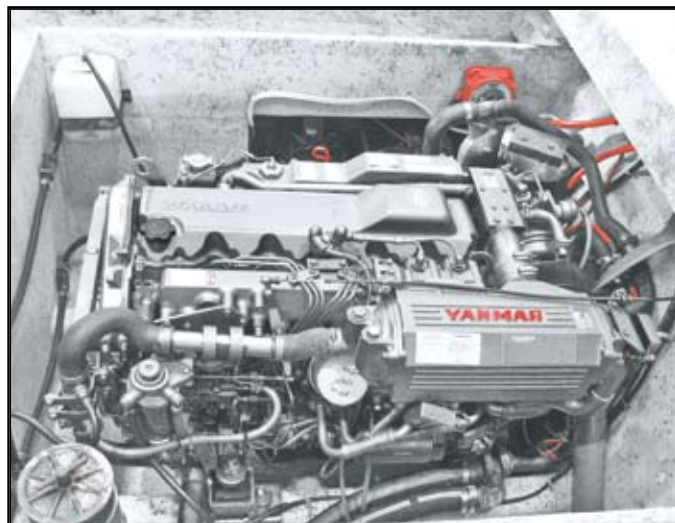

For more information on the full Yanmar line-up and to get a free copy of "The Boater's Guide to Successful Repowering", contact:

**DISTRIBUTOR:**  
Boatswain's Locker  
Costa Mesa, CA 92627  
866-908-2676  
[www.boatswainslocker.com](http://www.boatswainslocker.com)

**DEALER:**  
Coast to Coast Marine Diesel, Inc.  
San Pedro, CA 90731  
310-547-1700  
[www.coastmarinediesel.com](http://www.coastmarinediesel.com)

**DEALER:**  
Keefe Kaplan Maritime, Inc.  
Point Richmond, CA 94804  
510-235-5564  
[www.kkmi.com](http://www.kkmi.com)

**DEALER:**  
List Marine, Inc.  
Sausalito, CA 94965  
415-332-5478  
[www.listmarine.com](http://www.listmarine.com)

**DEALER:**  
Pacwest Marine & Industrial  
San Diego, CA 92106  
619-222-0475

**DEALER:**  
Total Yachts Works  
Mazatlan, Mexico  
669-913-4272  
[www.totallyachtworks.com](http://www.totallyachtworks.com)



**YANMAR**

**Legendary Reliability  
World Class Support**

# Monitor Windvane Gets Highest Scores in Customer Satisfaction in the 2009 ARC Gear Test

(Yachting World, Sept. 2009)

*The Monitor scored as follows (out of max 5):*

	Monitor	Brand X	Brand Y
Reliability	4.8	3.3	3.8
User Friendliness	4.0	2.8	3.4
Value for Money	4.0	3.2	3.1

- Monitor placed 4th on the Top Ten list of ALL products surveyed.
- Also rated BEST windvane in the 2008 ARC Gear Test



**THE GREEN SOLUTION!**

*The Monitor sailors "...found the product hard to criticize, with excellent performance."*

**SEE US AT THE ANNAPOLIS BOAT SHOW!**  
Tent C, #31

Learn more by visiting our website.

You'll find over 5,000 windvane installation photos. Check out a sistership!



**Official Sponsor**  
**2010 BAJA HA-HA**

FACTORY DIRECT  
**SCANMAR**  
INTERNATIONAL

**WWW.selfsteer.com**

432 South 1st St. • Pt. Richmond, CA 94804  
Tel: 510 215-2010 • Fax: 510 215-5005 • Toll Free: 888 946-3826  
email: scanmar@selfsteer.com

## LETTERS

Cleaning out a stuck head has to be one of the most heinous jobs on a boat. Furthermore, if Mr. Anonymous ever comes to Hawaii, he'll find that even the most luxurious charter boats don't allow toilet paper in the onboard heads. The typical passenger briefing goes something like: "Remember, if it hasn't passed through your mouth, it doesn't belong in the onboard toilet. This is one of the strictest rules we have, right up there with don't fall overboard!"

If this is indeed a 'deal breaker' for Mr. Anonymous and his spouse/partner — I hate to say it, especially as an instructor — but perhaps cruising isn't for them. And ditto everything the Wanderer said about total awareness of all of your crews' bodily sounds, smells, and so forth, as sounds and smells travel remarkably well in such a small space.

And double ditto on the taking a shower belowdecks thing. There is almost nothing a captain hates worse than hearing the water pump running because someone's taking a shower and draining the precious freshwater supply. It's why God gave us Solar Showers.

Mark Joiner  
Dolphin  
Wailea, Maui

*Readers — Due to the volume of mail on marine heads and showers, this topic will continue in the November issue.*

### ↑↓LOOKING FOR THE PERFECT BAY BOAT

I could use your readers' advice. I'm a partner in a 30-ft sailboat that is almost perfect for our purposes, which is daysailing on the Bay, often singlehanded or with non-sailors as passengers. She has the following good qualities:

- She's comfortable and spacious.
- She's a dry boat.
- She's low-maintenance, in part because she has no wood outside.
- She's a '00 boat, which means she's reasonably new.
- Her self-tacking jib makes her easy to singlehanded and easy to tack.
- And she's reasonably fast.

There's just one hitch. In 17 knots of wind, she starts to get unruly without a reef in the main. In 20+ knots of wind — in



SERGE ZAVARIN

**Greg would prefer not to heel over this much, and not to have to reef so often.**

other words, conditions we see every summer on the Bay — she's downright unmanageable. As a result, I have to reef and unreef several times during a daysail, and it's starting to feel like work.

So my question is whether there is a modern daysailer/weekend cruiser in the 30- to 35-ft range that will behave in winds in the mid-20s without 800 lbs of meat on the rail.

Greg Welch  
Planet Earth

*Greg — Even if you had your sails cut very flat for Bay conditions, and kept the traveller way down low to try to keep the boat on her feet, we can't think of a boat that's not going to*



**34th Annual**

**Saturday  
Dec 4 2010**

**Oakland/  
Alameda  
Estuary**

**Starting at  
5:30pm**

THIS YEAR'S THEME  
**Make The  
Season Bright**

Gold Star Sponsor



Celebrations on the Bay

Silver Star Sponsors

**Stem To Stern**



Enter your boat in the parade for a chance to win the \$500 Grand Prize or watch the parade from the waterfront in Alameda or at Jack London Square in Oakland.

We are collecting unwrapped toys and food for those in need.

# Lighted Yacht Parade

**[www.LightedYachtParade.com](http://www.LightedYachtParade.com)**

for more info and to register. Entry deadline: Dec. 3, 2010.

Entry fee: \$30 (incl a photo of your boat and a skippers goodie bag)

Hosted by Encinal Yacht Club, Oakland Yacht Club and Marina Village Yacht Harbor.



MARINA RIVIERA NAYARIT  
AT LA CRUZ

**MORE THAN 340 VESSEL  
CAPACITY (30-400 Ft)**

FUEL STATION - DRY DOCK - 150  
TON TRAVELIFT - YACHT CLUB

*El sueño hecho marina...*



*Come and enjoy our beautiful marina with first class  
services surrounded by spectacular views  
of the Banderas Bay.*



*"one of the best experiences, no hesitation in  
letting others know what a great place you have -  
thanks to all who made our stay so enjoyable"*

*Andrew Linney, www.nokaoi2.info*



**LAT 20°45'N / LON. 105°24'W**

Marina Riviera Nayarit, Marlin 39-A  
La Cruz de Huanacastle, Nayarit, MX 63734  
harbormaster@marinarivieranayarit.com  
Tel. (329) 295.5526 • Cel (322) 205.7467  
www.marinarivieranayarit.com

## LETTERS

be significantly overpowered in 25 knots of wind — even if she has 2,000 lbs of meat on the rail. For maximum performance, most boats need to be reefed at between 15 and 18 knots, and some as low as 12 knots. In 20 knots of wind, most smaller boats can benefit from two reefs.

You can get a good idea of what boat you might want based on the ratio of the sail area to the ballast. Since we're not up on that info for a lot of designs, we'll put the question to our readership. Is your 30- to 35-ft boat a stiffy? If so, what kind is she, and what tips do you have for sailing her flat?

Another way to avoid reefing is to plan carefully where you sail at what time of the day. For example, if you sail out of a marina in Alameda or the East Bay, you're less likely to reef if you sail to the Gate via Raccoon Strait and then back home via the Cityfront than if you do it in the opposite direction.

### ↑↓HEY, SHARK! GET OFF MY LINE!

I'm a bit surprised and disappointed that you published, on page 111 of the September issue, the photo of the idiot who caught and boated a shark during the Pacific Puddle Jump. Being people who love and respect the ocean, you should know that shark populations worldwide are quickly dwindling due to such practices as catching them, cutting off their fins for soup, and throwing them back to drown or bleed to death. In the future, let's not show photos of idiots gloating about their big shark catch, shall we?

P. Meyerhof  
Aphrodite, Islander 30 MKII  
Berkeley

P. — The shark populations of the world are indeed being decimated. For example, in '08, the last period for which we could find records, 75,000 lbs of thresher shark were landed by commercial fishermen in the Santa Barbara area, another 75,000 lbs in the San Diego area, 25,000 lbs in the Los Angeles area, and another 25,000 lbs in the rest of California. Again, this is just thresher shark, which is why you can find it in the

MICRONESIAN SHARK FOUNDATION



**It's shark harvesting such as this, not cruisers, that is decimating shark populations.**

fish section of just about any grocery store. To put this in some perspective, all of these areas are now landing only about 25% of the amount of thresher shark they got in '01, and just 10% of what they got in '82, which was the peak. The problem is almost certainly worse in Mexico, where the artisanal gillnet fishery goes after not just thresher shark, but also blue, hammerhead, white and Pacific angel sharks.

We don't claim to be experts, but it's our understanding that the United States, Mexico and international authorities have generally done a poor to abysmal job of protecting all fisheries, not just the shark fishery. Nonetheless, we don't think that Puddle Jumpers and other cruisers, who catch fish to eat them, rather than for commercial purposes, are the problem. But we'll happily remind all sailors that fish, like all other natural resources, from fresh water to oil, are in limited supply and should be consumed intelligently.

By the way, there's a big difference between gloating and having a laugh, and the cruiser in the photo was having a laugh.

EL SALVADOR

# ALL INCLUSIVE



Come and have a great time in the  
Second Annual Cruisers Rally in El Salvador.

Next March 12 to April 30, 2011



Visit El Salvador and do canopy, surf, rappel, rafting, walk in the mountains, discover beautiful towns, archeological sites, be captivated by its culture and folklore, shop, and enjoy a vibrant nightlife. Everything in one day; because El Salvador is all inclusive!



[www.elsalvadorrally.blogspot.com](http://www.elsalvadorrally.blogspot.com)



- The largest selection on the Bay. From basic to cutting edge.
- Factory-certified craftsmen. Navtec, Leisure Furl and Harken.
- In house, top-of-the-line machinery to build your custom rigging.
- Our direct purchasing assures you of the most competitive pricing.
- More than rigging, KKMI cares for your entire boat, making it safer and sail better.

## RIGGING SEMINAR

Learn from the pros how to take care of your rigging and more.

**Saturday, October 9, 10:00-Noon**  
**Pt. Richmond Boathouse**

For reservations, call (510) 235-5564  
 or email [mary@kkmi.com](mailto:mary@kkmi.com)

## THIS MONTH'S SPECIAL

**HARKEN** and  
**SCHAEFER**

Furling Systems

**35% OFF**  
 suggested list price

Plus: An additional **15% off**  
 our already discounted price  
 on all standing rigging.

**Pt. Richmond (510) 235-5564**  
**Sausalito (415) 332-5564**

**[www.kkmi.com](http://www.kkmi.com)**



## LETTERS

### ↑↓ INFERENCES AND ASSUMPTIONS

I get cranky when I see reports about sharks eating humans, such as in the September 17 *Lectronic*. The fact is that humans eat sharks to the point where they will not recover. I'm sure that you remember the days when the carcasses of large hammerheads lined the beaches in Baja and Punta de Mita, with only their fins removed. Are you suggesting that we get rid of the rest of the sharks? Shame on you!

Tom Steketee  
 Vermont

Tom — In that *Lectronic*, we reported that after landing a 12-ft tiger shark in the Bahamas, a fisherman noticed part of a human leg sticking out of its mouth. The shark was cut open and other human remains discovered. Using fingerprints, authorities were able to determine that it was the body of 43-year old Judson Newton, who had gone missing off so-called 'Jaws Beach' on New Providence Island, after he attempted to swim ashore from a disabled power boat.

Shame on us?! Please read the item again and try to find any recommendation, statement, suggestion, or even implication that sharks should be killed to save human lives. What a ridiculous idea. And what an even more preposterous idea to think we suggested anything of the sort.

### ↑↓ CRUISING AND 'UNSCHOOLING' WORKED FOR US

In response to Christine Currie's letter in the August issue, *Latitude* wrote, "No cruiser has ever told us that home schooling was easy." Well, we've homeschooled our daughter, Sequoia, for the last five years, including two seasons of cruising in Mexico, and it was certainly easier than dealing with the public school system in San Francisco!

Unfortunately, parents may think that 'homeschooling' involves re-creating the school environment at home, or on the boat, with the drudgery of textbooks and worksheets that have little relevance to the real world. It surprises me that many cruisers, who tend to think 'outside of the box' when it comes to their lifestyle, don't question whether our 'one size fits all' education system is right for every kid. We always felt sorry for cruising parents who spent hours a day butting heads with their kids over school work.

We adopted the 'unschooling' approach. Rather than following a traditional school curriculum, we looked for learning experiences in our day-to-day lives. Cruising in Mexico offered so many opportunities! When shopping, Sequoia calculated prices in pesos versus dollars. When we bought diesel, she converted liters to gallons. Baking was a great way to work with fractions, as we halved or doubled recipes.

In terms of science, we had identification books for fish, birds, and marine mammals, so Sequoia was our resident naturalist. After snorkeling, she'd identify all the fish she'd seen. When sailing, she'd scoop up jellyfish in a net. When dolphins rode our bow wave, she'd be on the bowsprit, cheering them on. And though she never wrote a report or took a test on cetaceans, I have no doubt that seeing these creatures in the wild has made a lasting impression on her and her life.

And though the cruising life can be full of activity, there is a lot of down time. Reading was a big part of everyday living for the whole crew. We also had lots of time for games. Multiplication War is a variation of the old card game that taught Sequoia her times tables. Bananagrams, a speedier version of Scrabble, is a family favorite. Scrambled States is a great way to learn U.S. geography. And trivia games like Brain Quest were a perfect diversion when we were underway.

Sequoia also spent time knitting and making jewelry. She

# A Perfect Fit for Any Vessel

You don't have to be a *Salty Dog* to find a great slip at Marina Bay.

Whether it's just for the weekend or a permanent berth, Marina Bay Yacht Harbor has room for yachts, multihulls, classics, and 'regular' boats too!

Slips are available in all shapes and sizes, with large end-ties open for multihulls or large yachts.

Convenient, sunny, and ready to welcome you to a new world of sailing from Marina Bay.



## Why stay at Marina Bay? Discover the difference...

### Marina Services and Amenities:

- Deep draft harbor
- Short sail to Central Bay & beyond
- Peaceful park setting
- Stunning City views
- Dock boxes & water at each slip
- Phone/DSL connections available
- Heated restrooms & showers
- Free pumpout stations
- Guest berthing available
- Shoreside storage units available
- Can accommodate vessels 20'-120'
- Easy freeway access
- On the San Francisco Bay Trail
- Electronic Gate Control on docks
- 30-amp & 50 amp shorepower
- Amini's Deli & General Store on site
- Salute E Vita Italian Ristorante on site
- The Boilerhouse Restaurant nearby
- Close to public transit & BART
- Nearby boatyards & chandleries
- Live bait (in season)
- Boat washdown stations
- Meeting & event facilities available
- Free Wi-Fi
- Free ice
- Laundry facilities
- Public launch ramp
- Video surveillance
- Ample free parking

**Marina Bay Yacht Harbor**

**(510) 236-1013**

**[www.MarinaBayYachtHarbor.com](http://www.MarinaBayYachtHarbor.com)**



# WHALE POINT MARINE & HARDWARE CO.

**A FAMILY OWNED & OPERATED BUSINESS FOR THREE GENERATIONS**  
**MARINE PARTS & ACCESSORIES, PLUS A COMPLETE HARDWARE STORE**

Go to [WhalePointMarine.com](http://WhalePointMarine.com) for additional discounts!

## AIR DRYR 1000



Handles up to 1000 cu. ft.  
Safe for marine use.  
**Now \$54<sup>99</sup>**

## PORTABLE HEATER

Indoor safe propane heater.



**Mr Heater**  
4,000-9,000 BTU: **NOW \$99<sup>99</sup>**

## DOCK-RITE Boat Fenders



6.5" x 21" • **NOW \$18<sup>99</sup>**  
8.5" x 27" • **NOW \$29<sup>99</sup>**

## DECK BRUSH with Handle



Extra long handle (5ft) with aluminum no-rust, threaded tip.  
**Now \$13<sup>98</sup>**

## OLIN FLARE KIT

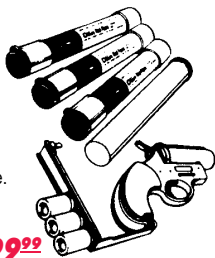

Model #544  
Includes case.

List \$149.99  
**Now \$99<sup>99</sup>**

## GUEST Battery Charger

Atomic Battery Chargers, 3 stage



Model...	Amp.	Bank	.....	List	.....	Now
2611	10	2	.....	\$179	.....	<b>\$124<sup>99</sup></b>
2613	15	3	.....	\$259	.....	<b>\$199<sup>99</sup></b>
2620	20	3	.....	\$289	.....	<b>\$269<sup>95</sup></b>

## RAYOVAC 6V Floating Lantern

**NOW \$7<sup>99</sup>**



Large size flashlight is waterproof, which means it floats and comes with 6V battery.

## FILTER 500 FGSS by Racor



Filter Element **Whale Pt \$9<sup>99</sup>**  
Filter Unit: List \$246.99  
**Whale Pt \$179<sup>99</sup>**

**205 Cutting Blvd, Corner of 2nd, Richmond**  
**510-233-1988 • FAX 233-1989**

Mon-Sat: 8:30am - 5pm • Sun: 10am - 4pm • [whalepoint@acehardware.com](mailto:whalepoint@acehardware.com)

Go to [WhalePointMarine.com](http://WhalePointMarine.com) for additional discounts!

## LETTERS

bought a recorder at a swap meet in La Paz, found two books about how to play it by asking on the morning net, and taught herself to read music. This is not to mention all the knots she learned to tie, how to drive the dinghy, and all the cool sailing stuff she would have never learned in school! The only task we gave her was to keep a travel journal. Because there were so many exciting things to write about, she was generally happy to comply.

One of the great things about cruising is that everyone is trying something new. Whether it's how to surf-land your dinghy or fix a finicky outboard, the learning process is a part of daily life. When your kids see you take on new challenges, struggle, fail, and (hopefully!) ultimately succeed, they'll be better prepared to do the same.

In terms of Christine Currie's particular situation, I can't say whether homeschooling is the right choice for her family, but I agree with *Latitude's* opinion that "most active young boys would get a better and more useful education cruising on a boat than they would caged up in almost any classroom in America, at least until high school age".

It seems to us that most kids are happy cruising until they are about 12, at which point living on a boat with your parents loses some of its appeal. Indeed, our daughter decided she wants to go back to school and will be entering eighth grade this fall. Compared to the dread with which I faced middle school, her enthusiasm is remarkable!

I've always tried to approach giving parenting advice the same way that one should go about giving anchoring advice. In other words, keep it to yourself! What works for some families may not work for others. But I can say that for our family, cruising and unschooling went together perfectly. We encourage other families to cast off the dock lines and figure out what works for them!

Susan Detwiler & Todd Huss  
Sugata, Hans Christian 38  
Emery Cove Marina

*Susan and Todd — So much of the education system in the United States seems ineffective and/or dated. About five years ago, we watched a KTVU 2 news segment in horror as the head of math for the Oakland Schools repeatedly declined to attempt to solve a grammar school-level math problem, such as what's 3 times 30. She begged off, saying it had been a while since she'd gone over such material. Had she seen it, Mrs. White, who did such a great job teaching us geometry at Skyline High in Oakland in the mid '60s, would have been furious.*

*Our son and daughter were lucky enough to be able to attend excellent public schools until middle school in Southern Marin, where most of the administrators, teachers and parents really cared. What a rarity! Even so, it wasn't a good fit for our son — and a lot of other boys — who seemed to be too kinetic to thrive in such a restrictive environment. We're sure our son would have gotten a better education if we'd taken him around the world on our boat, where he could have learned by doing and observing.*

*Education methods haven't seemed to progress much in the last 100 years, but some brilliant folks finally seem to be doing something about it — and at a pittance. Better yet, they are doing it in ways that are ideal for kids who are going cruising.*

*Consider 33-year-old Sal Khan, who was born and raised in New Orleans by a Calcutta-born mother and a Bangladesh-born father. Using basic and inexpensive equipment — we're talking a \$200 Camtasia recorder, free Smooth Draw 3 software, and an \$80 Wacom Bamboo Tablet on a PC — Khan has personally made more than 1,600 educational videos on everything*

**GARHAUER**  
MARINE HARDWARE

*GREAT  
GEAR*

See us at  
the Annapolis  
Boat Show



## Quality stanchions and gates from Garhauer

**W**hether you are replacing one stanchion or upgrading your entire boat, we manufacture a complete line of stanchions, bases and gates.

- Stanchion tubes available in 3 different tip styles
- Stanchions and gates can be made removable or with fixed bases.



**GARHAUER**  
MARINE HARDWARE

1082 West Ninth Street,  
Upland, California 91786

Phone: (909) 985-9993  
FAX: (909) 946-3913

email: [garhauer@garhauermarine.com](mailto:garhauer@garhauermarine.com)  
<http://www.garhauermarine.com>

# Svendensen's Marine is your one-stop shop.

As your exclusive Northern California  
authorized dealer for Laser Performance  
sailboats, we stock the **complete  
line of new Laser boats.**

We also stock **trailers and  
dollies by Seitech,  
EZ Loader  
and Kitty Hawk.**



**SVENDSEN'S  
MARINE**

Located in the Alameda Marina, at 1851 Clement Avenue  
510.521.8454 | svendsensmarine.com

## LETTERS

from basic arithmetic through the most sophisticated biology, chemistry, organic chemistry and physics, to a four-part series on the French Revolution. These courses — which are taught in 10-minute segments — are available to everyone in the world with internet access . . . for free! Khan says that since he already has a beautiful wife, a hilarious son, two Hondas and a decent house, his goal in life is to create the world's first free, world-class virtual school, where anyone can learn anything. He's gotten enthusiastic reviews from the likes of Bill Gates.

Could it be that the old education model of tens of thousands of well-intentioned, but perhaps not always the most talented or inspired, teachers facing an overwhelming number of distracted students in prison-like settings might be in for a change?



WWW.KHANACADEMY.ORG

**Could watching free videos from the Khan Academy be a solution to onboard home-schooling?**

What if all students could receive instruction from the most gifted 1% of the teachers in the country, and for a fraction of what education is costing today? And get education in areas they are really interested in?

If you're about to go cruising with a child, we recommend that you check out the Khan Academy, or something similar. If you check the list of free classes, we're pretty sure you'll see some you'd like to take yourself. And would that set a great example for your child?

By the way, we consider our iPad to be one of the finest educational tools ever. As long as you have internet access on your boat — which is getting more common and better all the time — you can find the answers to almost anything from science to history, and learn to appreciate things like music and art, while lying in your bunk. Over the years we wasted a lot of time reading junk novels while cruising, but now we've got a whole-grain diet of stuff to read at our beck and call. And very often for free.

### ↑↓ A TEAM CALIFORNIA CREWMEMBER'S PERSPECTIVE

I'm writing in response to Brian Trelivijg's July letter and Lee Turner's August letter about the way the Clipper Cup fleet was received in San Francisco. Speaking as a member of the *Team California* crew, the City of San Francisco, the Golden Gate YC, Customs and Immigration, and the State of California are not to blame for the poor fleet reception on April 4. *Latitude* is correct that these events are usually arranged and paid for by the race organization, not local governments.

The *Team California* entry was not "the State of California's representative," it was a boat branded by Clipper Ventures, the for-profit organization that owns one of the (now) nine boats in the around-the-world biennial 'race' it hosts for paying amateur crew. The State of California can barely cut me a paycheck, let alone dump bags of money into an aging fiberglass yacht flying a British flag with mostly British crew. This state was never part of any Clipper event. And, in fact, only six of the 42 crew were from California.

Governor Schwarzenegger promised nothing to Clipper Ventures or to their branded entry *Team California*. His office simply wrote a nice form letter sending his "best wishes for success." I have a similar letter that his office sent to me in '04



**PETTIT**  
  
**Simply better.**

Photo by Billy Black

## FLASH THEM SOMETHING VIVID TO REMEMBER.

DO IT WITH VIVID, THE HARD ABLATIVE ANTIFOULING THAT COMES IN 24 BRIGHT COLORS PLUS THE WHITEST WHITE AND THE BLACKEST BLACK. BURNISH IT TO A HARD, FAST RACING FINISH AND NOT ONLY WILL YOU FLY PAST THEM, YOU'LL GIVE THEM A FLEETING YET MEMORABLE GLIMPSE OF YOUR WILD SIDE.



[www.pettitpaint.com](http://www.pettitpaint.com) • 800-221-4466

# LETTERS

for representing the United States in a different international athletic competition.

Clipper Ventures used this letter, and Governor Schwarzenegger's fame, to market their event, and to imply that he was somehow endorsing *Team California* and that he would attend events at the San Francisco stopover. The fact that Schwarzenegger even sent this letter, and sent a representative to one crew event in San Francisco, was actually due to the efforts of Bob DeWitt of the Santa Cruz YC, and of my father, former Assemblyman William T. Bagley. Schwarzenegger was in the middle of the health care and budget crisis, and had no duty whatsoever to be in San Francisco late on a Sunday evening.

It is true that there were over-the-top welcomes and bon voyage ceremonies at different ports during the race, but they were all at ports where there was a bona fide, cold,



CLIPPER VENTURES

**There was great sailing and high adventure in the Clipper event . . .**

hard cash-paying sponsor — such as Hull, Qingdao, Singapore, Cape Breton Island, and Kinsale/Cork. The asking price for full sponsorship was in the realm of four million British pounds — about \$6 million U.S. There were

no "warm welcomes" in Rio, Port Kingston, or New York City, which, like San Francisco, didn't have a sponsor.

The stopovers at the sponsoring cities were also wisely held in conjunction with other non-sailing festivals, creating the appearance of a larger fan base. Making things more difficult for San Francisco, a stopover wasn't even confirmed until midway through the event. Clipper had never had a stopover in San Francisco before, and not many people — especially non-sailors — even knew the event existed. Furthermore, both the anticipated arrival of the fleet in San Francisco and the restart date changed almost daily because of multiple yacht breakages on the way to China and on the way to San Francisco. And the restart went from a weekend to a weekday. Consequently, it wasn't so easy for local sailors — or anyone else — to know when this was supposed to happen.

The anticipated arrival of *Team California* was uncertain because they lost the ability to communicate because of a dismasting. After the dismasting, *Team California* didn't have paper charts either, as the skipper, defying logic, jettisoned them into the Pacific. So the boat's position wasn't readily available.

The U.S. Immigration Service did the 70+ crew a favor by arriving at the yacht club after hours and processing all the boats at once. They could have made the crews stay onboard until the next day and processed them during normal business hours. The officials were professional and very patient.

I'm not sure what other "officials" should have attended the arrival of these boats. Our elected officials have jobs to do and families to care for, and there is no requirement that they attend every social event throughout the City. Again, *Team California* and her gracious escorts didn't arrive during normal business hours. Representatives from Mayor Newsom and Governor Schwarzenegger's offices did appear at a subsequent crew event, and gave kind and encouraging words to the participants.

**SAIL TO  
OUR NEW  
MARINA**

**NEW  
A&B DOCKS  
NOW OPEN!**  
Next docks  
coming soon

**Great Long-Term  
Lease Deals**

- Up to 15 Years •
- electricity
- deli facilities
- fire fighting system
- waste disposal
- fuel dock
- 24/7 security
- wi-fi

Official Sponsor  
2010  
BAJA  
HA-HA

LAT. 20°41'22"N • LONG 105°17'28"W



WWW.MARINANUEVOVALLARTA.COM

MONITORING VHF 16

PH: 52 (322) 29 77 000

HARBOR MASTER: JUAN S. ESTRADA

JUAN@MARINANUEVOVALLARTA.COM

Call us about our  
**FALL DISCOUNTS**  
in effect through the  
end of October!

# THE FINEST SAILS BEGIN WITH THE BEST SAILCLOTH

Our patented woven Vectran® sailcloth performs like the laminates with the durability of Dacron®, especially in roller furling applications. In fact, Vectran® is lighter, lower stretch, and retains its shape over a longer life than any sailcloth we've ever offered to cruising sailors. That's because Hood Vectran® is woven, not laminated to Mylar® film. And you can be sure that each sail we roll out is built by hand, with the same care and craftsmanship that has been the Hood hallmark for 50 years. To discuss your sailcloth needs – whether our state-of-the-art Vectran® or our soft, tight-weave Dacron® – give us a call today.

**HOOD** Sails & Service

**HOOD** New Sails

**HOOD** Sail Repairs

**HOOD** Furling Conversions

**HOOD** Pickup & Delivery

**Outbound Yachts**  
**New Outbound 52**  
with Hood Vektron  
Vertical Full Batten  
In-Mast Furling  
Mainsail and 135%  
Vektron Genoa

PHOTO COURTESY  
SWIFTSURE YACHTS

**HOOD**  
SAILMAKERS

**HOOD SAILMAKERS 466 Coloma Street, Sausalito, CA 94965**

**Call Robin Sodaro (800) 883-7245 (415) 332-4104 Fax (415) 332-0943 hoodsails@aol.com**

**Visit our website for Special Online Discount Pricing... [www.hoodsailmakers.com](http://www.hoodsailmakers.com)**

# AIS Made Easy!

Latest, most cost-effective collision-avoidance solution

AIS (Automatic Identification System) receivers enable AIS-capable chart plotters and navigation software to see other vessels. AIS transponders allow other vessels to see you.

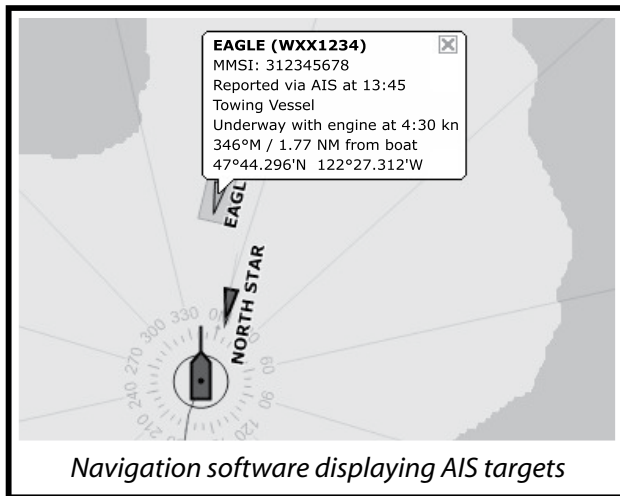

Milltech Marine offers complete, low-cost AIS solutions. Visit our web site for information on:

- ✿ AIS Receivers - featuring the Comar AIS-MULTI
- ✿ AIS Transponders - including Class B AIS
- ✿ Navigation Software
- ✿ Antennas, cables and other accessories



Order any product online and use coupon code "LAT38" to get free shipping in the U.S.

For more information contact:



(866) 606-6143  
www.MilltechMarine.com

## LETTERS

In actuality, on the night of arrival, all the crew wanted to do was have a few cold drinks, a meal that didn't come out of a tin, a shower, and some sleep. Other than one slab of warm beer at the dock from Clipper Ventures, all of the drinks and food at the Golden Gate YC were provided by joining crew, friends and family. Clipper did not sponsor this welcoming event.



LATITUDE / LADONNA

Logistically, there are few marinas that could have handled all nine of the 68-ft racing yachts. The people at the San Francisco Marina Yacht Harbor did their level best to accommodate all of the boats and the more than 200 crew. One cannot expect them to displace permanent slip holders. The harbor master was patient with the constant ingress and egress of the many crew throughout the two-week stopover. This is not the first port stop where the boats were not all right next to each other. Besides, after spending seven months together, sometimes distance is a good thing.

... but the organizers promised more of Governor Schwarzenegger and others than they should have.

Clipper Ventures repeatedly hinted that crew might get to meet Governor Schwarzenegger, and that the Jamaica crew might get to 'race' with Usain Bolt, the Jamaican sprinting star, and similar things. The crews were unnecessarily promised many things like this that never materialized. Other than soggy underpants for 10 months, not much in the Clipper race is free.

Shana Bagley  
'09/'10 Team California Crewmember

Shana — Thank you for a crewmember's perspective of the event.

### ⇕ SHIPPING BENEFITS SAILORS TOO

I can't help commenting on the September 15 *Letronic* item about boats having to take evasive action in the Oakland Estuary in order to not be hit by ships. Correspondent Goose Gossman — love the name! — wrote, "You really have to wonder where all the stuff in those big metal boxes is going — and if the enormous trouble humans go through to get it is worth the effort."

As a Port Commissioner at one of several ports in the Bay Area, I can answer that question. According to the U.S. Department of Transportation statistics, about 95% of United States foreign trade that passes through our port system is transported by water. That means most of our consumer goods — clothes, furniture, food, electronics, and so forth — come by ship. More than half of it comes to West Coast ports and moves east by rail or truck. In California, it's mostly through containers to Oakland, Los Angeles and Long Beach.

This transportation is far more fuel efficient and cost-effective than other methods of transportation. That's why the Department of Transportation is initiating a "Marine Highways Initiative" intended to move goods from port to port within the U.S., in addition to our current import/export activity.



## THE FINEST MARINA IN BAJA

**Marina CostaBaja, at the Gateway to the Sea of Cortez in La Paz, South Baja.**

Marina CostaBaja's protected location, concrete docks and double basin design offers controlled access to 250 prime slips for vessels ranging from 30-200 feet.

### OUR PRIME FACILITIES

Potable desalinated water • Secure dock boxes • Largest fuel dock in the area • Crew lounge  
 Pump out service • 24 hour security • Laundry service

### CALL US NOW AND ASK FOR SPECIAL SHORT AND LONG TERM SLIP RATES

While you are here receive a 10% discount at the SPA located at the new hotel CostaBaja Resort & Spa and special Golf Course rates. TOLL FREE: 01-866-409-9940

Visit CostaBaja, a master planned community and enjoy Golf or relax at the Beach Club or choose your future home among a variety of Condos, Villas and Townhouses.

**Discover the most beautiful bays, islands and marine life in what is known as "The Aquarium of the World".**



**COSTABAJA**

Unique living on the Sea of Cortez  
 marina • golf • residences

Gabriel Ley (Marina Manager)  
 info@costabajaresort.com  
 011 52 (612) 121-6225  
[www.marinacostabaja.com](http://www.marinacostabaja.com)



- NEW  
- USED  
- REFINANCE



# Boat Loans Made Easy®



Let our 29 years of experience go to work for you!

**Richard Tressler**  
866-377-3948 ext. 1047008

**www.essexcredit.com**

EQUAL CREDIT OPPORTUNITY LENDER

Loan Amounts from \$25,000  
Instant Loan Approvals\* • 90 Days to First Payment\*

\*Subject to Loan Program Guidelines and Credit Approval  
Reference Code = MAR931

## LETTERS

From the perspective of recreational mariners, most of the deepwater ports would not stay dredged if it weren't for shipping activity. Recreational boating revenue is usually not large



GOOSE GOSSMAN

**Trains move a ton of goods 500 miles using just one gallon of diesel. Ships do almost as well.**

enough to sustain the deeper drafts required for sailing vessels in many harbors, creeks, rivers and inland waterways. So, yes, it is worth the effort. And the next time your sailboat has to give way to a shipping vessel, give them a wave of thanks because they are both a major part of our Bay Area economy and critical to our boating community.

Lorianna Kastrop, First Mate  
Goose, Catalina 30  
South Beach  
Commissioner, Port of Redwood City

*Lorianna — Thank you for the letter. It seems counterintuitive — which is why some environmentalists and locavores have such a hard time getting their heads around it — but transporting goods, including food, by large ship is astonishingly fuel- and cost-efficient. We feel no guilt in buying cherries from Chile in the winter at big box stores because we know they got to us using less fuel per cherry than those arriving in corner markets from the Central Valley in the early summer. Nonetheless, we always stand a good watch so as not to be run down by a ship full of cherries, furniture, appliances, and all the rest.*

### ↑↓ SURE, THERE MIGHT BE WORSE THINGS IN LIFE

Not funny. I was hoping I could grab a copy of the September *Latitude* right after it hit the streets, but my stupid homeowner's association picked today to have sealant applied to our driveways — five months after they'd been paved! I



LATITUDE / RICHARD

**No worries when you can't get to a 'Latitude', because it will get to you online — for free!**

I could have left my car on the street, except that street sweeper schedules have us doing the 'musical parking spot' game every three hours. So I'm stuck in for two days. Now I know there are worse things that can befall a human than being denied immediate gratification of their *Latitude*, but

I consider it akin to having my hands tied behind my back. If I start to get the shakes, I'll walk over the Aeolian YC and pick up a copy.  
Carolyn Samit  
Alameda

*Carolyn — Thanks for the very kind words. You'll be happy to find out that Latitude is also available online — including back issues to May '07. While we know most readers prefer to hold the magazine in their hands, the photo reproductions online are spectacular!*

# COME VISIT COYOTE POINT MARINA:

*The Peninsula's Complete Recreational Destination!*



**Multihull  
side ties available  
up to 40 ft.**

## **BERTHING**

- Slips to 40' available
- Inside ties from \$85 per mo.
- Multihull side ties available
- Check out our rates!



## **FUEL DOCK & PUMP OUT**

- Open 7 days per week
- Gas and diesel available
- Check our prices
- Free pump outs



## **COYOTE POINT RECREATIONAL AREA – HOME TO:**

- Coyote Point Marina
- Poplar Creek Golf Course
- Coyote Point Park
- Captain's House Conference Center
- Beach, Picnic & BBQ Areas
- Coyote Point Yacht Club
- Dominic's Restaurant
- Magic Mountain Playground
- Coyote Point Museum
- Shoreline Trail

**COME FOR A VISIT – WE THINK YOU'LL STAY**

*Call us and mention this ad for a FREE Weekend Guest Berth*

**COYOTE POINT MARINA ~ 1900 Coyote Point Drive • San Mateo**

**650.573.2594**



- Factory-certified technicians. Dealers for B&G, Simrad and more.
- No one can install or service your boat's systems more efficiently than KKMI. Our floating ServiceShip saves you time and money.
- Our direct purchasing assures you of the most competitive pricing.
- More than electronics, KKMI cares for your entire boat, making it safer and sail better.

## ELECTRICAL SEMINAR

Learn about the correct tools and latest equipment, even 'how to' tips from our pro's 35 years of experience outfitting yachts for ocean voyaging.

**Saturday, October 16, 9:00-Noon  
Pt. Richmond Boathouse**

For reservations, call (510) 235-5564  
or email [mary@kkmi.com](mailto:mary@kkmi.com)

## THIS MONTH'S SPECIAL

**B&G H2000 owners:**

Here's your opportunity to upgrade to the new H3000 system. Use your existing sensors (wind, depth, speed and compass). Just replace your processor and one display (GFD) and use your existing FFDs. Call us for pricing... it's low to print!



**Pt. Richmond (510) 235-5564  
Sausalito (415) 332-5564  
[www.kkmi.com](http://www.kkmi.com)**

## LETTERS

### ↑↓ THE ART OF BOAT NAME PRONUNCIATION

A reader asked what cruisers do for health insurance. My out-of-country insurance coverage is probably applicable to only a few folks, but since you asked, I'm a retired soldier and insured under Tricare for Life. Since I'm also a qualified geezer citizen, I'm covered under Medicare as well.

Tricare for Life has issued me a statement declaring to any country that my insurance will cover me anywhere on the planet. Since more than a few military retirees become ex-pats and live abroad, out-of-country claims are routine for Tricare.

By the way, I had to show proof of my health insurance to the French consulate in San Francisco before they would give me a visa extension for French Polynesia beyond the normal six months. I, for one, want more than three months in those islands when I get there next year. By the way, the consulate was pretty adamant about not giving the extension without seeing proof of health insurance.

We'll see you on the Ha-Ha later this month. I did it in '00 with a different boat, a Maple Leaf 42, of the same name as the one I have now. I doubt that the Poobah will pronounce *Balquhiddier* any better this time than last, but I'm good with that. I made a bunch of cruising friends on the '00 rally, including some that I buddyboated with down south, and some with whom I crossed the Atlantic to Europe in '01. I'm looking forward to this year's Ha-Ha!

Don Patterson  
*Balquhiddier*, Hunter Passage 450  
Tacoma, WA

*Don — We're glad that you have the health insurance, but hope you never have to use it. Our apologies for mispronouncing your boat's name during the last Ha-Ha, but Gaelic, let alone Scottish Gaelic, has always been difficult for us. We promise to try harder this year.*

### ↑↓ ANOTHER MEMBER OF THE 'OVER 30 CLUB'

In the early '70s, Tom Wylie designed a half-tonner, built a mold, and popped out *Animal Farm* and *Hawkeye*. In succeeding years they would both win the World Half Ton Championship. Tom then tweaked the keel position and designed a fractional rig, and the popular Hawkfarm one-design class was born. I had been racing *Fledgling*, my 24-ft wood Golden Gate, and swapping season championships with George Schuldt on *Smoothie Too*. Schuldt and I both made the move to the Hawkfarm fleet at the same time. Mine was *Eclipse*, hull #9 of the original run of 10 boats. She was launched and commissioned in August of '76, and I've owned her ever since.

I was in the early stages of my career back then and not making a lot of money. In fact, the bank turned down my initial application for a boat loan. I went back to the loan officer, explained that sailing was what I did, and offered to double the downpayment. He then approved the loan. I had to sell *Fledgling*, my El Toro, and everything else that I had of value to make that downpayment.

I live in Alameda, and used to go down to Wylie Design Group each evening after work to watch the progress on *Eclipse*. It was interesting to watch the tension between Tom Wylie and Dave Roberts, the production manager. Tom would say, "Dave, we have to make them light." And Dave would respond, "Tom, we have to make them strong." The result was a remarkable 28-ft medium displacement stiff boat that sailed to her rating on San Francisco Bay and the Gulf of the Farallones in varying conditions during all times of year. And the design has stood the test of time.





[www.marina-mazatlan.com](http://www.marina-mazatlan.com)

468 slips from 30 to 260 feet length  
125/250 V 30, 50, 100 Amps.



For all reservation and details  
Contact: [elvira@marina-mazatlan.com](mailto:elvira@marina-mazatlan.com)  
[elviramarinamazatlan@gmail.com](mailto:elviramarinamazatlan@gmail.com)  
Phone: 011 52 669 2936  
Phone & fax: 011 52 669 669 2937

Real Estate  
[www.marinamazatlan.com.mx](http://www.marinamazatlan.com.mx)

## 2011 Summer Special Package!

Stay 5 months from June 1st to October 31st, 2011  
at USD \$ 0.24 cents per foot per day

plus 16% tax

Boat must be here from June 1st to October 31st, 2011.  
(metered power extra)

### 2011 WINTER CRUISING RATES: NOV. 1 2010. THRU MAY 31 2011.

SIZE OF BOAT	0' TO 41'	42' TO 60'	61' TO 90'	90' OVER
TIME OF STAY				
01 TO 07 DAYS	\$ 0.95	\$ 1.05	\$ 1.40	\$ 1.80
08 TO 29 DAYS	\$ 0.60	\$ 0.70	\$ 1.00	\$ 1.30
30 TO 90 DAYS	\$ 0.43	\$ 0.61	\$ 0.70	\$ 1.00
91 DAYS OR MORE	\$ 0.36	\$ 0.43	\$ 0.50	\$ 0.60

RATES, IN U.S. DOLLARS, ARE BASED ON DOCUMENTED LENGTH  
AND DO NOT INCLUDE 16 % TAX. 30 FOOT MINIMUM CHARGE.

Harbor Master : Jaime Ruiz email: [jaimeruiz@marina-mazatlan.com](mailto:jaimeruiz@marina-mazatlan.com)

# Sailing Away?

We build custom  
sails to suit your  
needs, your boat,  
your plans.



Keep cruising with  
**HOGIN SAILS**



- New racing or cruising sails
- Roller furling conversions
- All sails manufactured at our Alameda loft
- Repair and service
- Custom boom covers
- ATN spinnaker/genoa sleeves

In the Alameda Marina at  
1801-D Clement Ave., Alameda, CA 94501

**510.523.4388**

Mon-Fri 8:30am to 5pm  
Saturday by appointment only

[sales@hoginsails.com](mailto:sales@hoginsails.com)  
[service@hoginsails.com](mailto:service@hoginsails.com)  
[www.hoginsails.com](http://www.hoginsails.com)

## LETTERS

The Hawkfarm class qualified for the ODCA (One Design Class Association) in our first year on the water, and the enthusiasm of those original owners was infectious. We sought out racing opportunities wherever we could find them, including One-Design, Midget Ocean Racing Association (MORA), and Handicap Divisions Association (HDA). We even tried to get accepted into the Small Boat Racing Association (SBRA), but were turned down. When there was no yacht club-sponsored race for us, we set up our own Wylie Weekends and used rabbit starts. We raced almost every weekend, and often two days per weekend. I was the youngest and least experienced skipper in the group, and my learning curve was steep. But I had a talented group to show me how it was done.

Several of the original Hawkfarms had multi-generational crews, with young folks who had grown up in junior sailing



FRED HOFFMAN

**After 36 years, the Hawkfarm 'Eclipse' is still going strong.**

programs around the Bay. The formidable Patrys on *Man-face* slugged it out with the Vincents on *Mercedes*, the Nashes on *El Gavi-lan*, the Schuldts on *Cannonball*, the Lowells on *Flying Circus*, and later the Desenberges on *Sparrowhawk*. In addition to these family boats, there were also other highly-skilled skippers: Tony Thomas on the first Hawkfarm, *Heatwave*; Len Cheney on *Hotcakes*; Paul Altman on *Predator*; and Warren Sankey on *Jenerator*. The excitement and enthusiasm of the new fleet also drew attention from world-class sailors who often appeared on one or another of the boats. Folks like Kim Desenberg, Kame Richards, Bob Smith, Chris Corlett, and Dee Smith. Over time, *Eclipse* and I began to gradually move up into the middle of the fleet.

In those early years and into the early '80s, I built a crew from a group of underachieving rugby players who lived in Santa Cruz and loved sailing *Eclipse* on the Bay. We called them the Sweathogs, and they called me Mr. Kotter. They were big and strong, willing to learn, and were great fun to be around. Sweathog stories from those years abound, but two are truly memorable. On one race against Dee Smith, who has gone on to America's Cup and other world class sailing, the Sweathogs took umbrage at the way that they perceived he was treating their skipper. When we had cleared our finishing marks, they jumped Dee and threw him overboard. Dee took it in good humor, but I was appalled.

Before a postponement of another race off the Berkeley Circle, we drifted close to *Predator*. The Sweathogs reached out, grabbed *Predator's* lifelines, jumped aboard, and ducked down below to steal the lunches from their icebox before rushing back to *Eclipse*. Much to my distress, *Predator's* sandwiches were better than mine — and I never heard the end of it.

With the Sweathogs on board, *Eclipse* finally won a MORA Season Championship. But the Sweathogs just couldn't seem to get to the boat on time on race days, so I fired them and began to build a crew of 'adults'. Paul Altman immediately jumped on the now available Sweathogs. The next time we raced was during a very blustery day on the Bay, the kind of conditions the Sweathogs took pride in excelling in. My adult crew and I beat them by several boatlengths. Life was good!

Management  
Consulting  
Development



## Almar Marinas

Join one Almar Marina and you have reciprocal privileges at any of Almar's 17 locations from San Francisco to San Diego and out to Hawaii. Programs included in your slips fees:\*Boat Handling Classes\*Navigation Courses\*Electrical Courses\*Anchor Outs\*Seminars on Local Destinations.



EST. 1973

[almar.com](http://almar.com)

San Diego\*Cabrillo Isle Marina\*Marina del Rey\*Marina del Rey Marina\*Channel Islands Harbor\*Bahia Marina\*  
Anacapa Isle Marina\*Peninsula Marina\*Westport Marina\*Ventura Harbor\*Ventura Isle Marina\*San Francisco  
Bay\*Treasure Isle Marina\*Jack London Square\*Jack London Square Marina\*Oakland\*NEast Basin Marina  
\*NWest Basin Marina\*Embarcadero Marina\*Union Point Marina\*Alameda\*Ballena Isle Marina\*Martinez\*  
\*Martinez Marina\*CA Delta\*RiverPoint Landing\*Honolulu\*Kewalo Basin Harbor\*Oahu\*Iroquois Marina\*

Outboard Engine Owners:

## WE UNDERSTAND



When an engine dies, there's no walking home – just costly repairs, lost vacation time, and lost revenues.

**Don't find yourself in this boat. Regular maintenance prevents expensive repairs.**

We are *your* experts for outboard diagnostics, repair, repower, sales and service.



- Factory-trained and certified techs
- Open six days a week
- New and used engines bought and sold
- One-year warranty on all work performed and used engine sales
- Three-year warranty on all new engines

**You will *not* find this knowledge, reputation and network for less.**

## MARINE OUTBOARD

since 1990

OUTBOARD SALES, SERVICE, REPAIR, PARTS

**(415) 332-8020**

Nissan  
Tohatsu  
Johnson  
Evinrude



Honda  
Mariner  
Mercury  
Yamaha

**35 Libertyship Way • Sausalito, CA 94965**

**Conveniently located at Libertyship Marina**

*If we're not maintaining your outboard, you've missed the boat!*

## LETTERS

*Eclipse* went on to finish second in the '81 MORA long distance race to San Diego. After the race, the race crew flew home and the delivery crew — including my girlfriend Rose — flew in. A few days later we were bashing our way north into big, cold, square waves at Conception and later Arguello, when Rose decided the only way we were going to survive was to get some hot food into us. So she went below and prepared it. That's when I decided to ask her to marry me. She agreed, and we began growing new crew from the beginning. One of my favorite sailing photos is of the *Eclipse* National Champion crew taken in '86 at the San Francisco YC, with our shore support team of Rose, 3-year-old David, and 3-month-old Ben.

One of my greatest days on *Eclipse* occurred in the late '90s. With Rose and both my then-teenage sons aboard, we won our race. I remember feeling like it just didn't get any better than that.

After 35 years of racing and cruising *Eclipse*, I can honestly say that the boat has never disappointed me. Although we are sailing less than before, we are still racing and enjoying every sail. But with the kids now gone and other activities beckoning, I have sadly decided to put *Eclipse* up for sale. But I would like to thank the entire sailing community for the past 40 years of excellent sailing, support and friendship. The wonderful thing about this sailing is that there is always more to learn, and the boat, the wind, the water, and the sailors keep reminding us and teaching us.

Fred Hoffman  
*Eclipse*, Hawkfarm  
Marina Village, Alameda

### ↑↓ EQUAL TIME

In the September issue of *Latitude*, Stuart Gregor wrote demanding to know what Republican has done worse things than Massachusetts Senator John Kerry, who didn't pay taxes on the \$7 million sailboat he had built in New Zealand.

I give him Randy 'Duke' Cunningham, former U.S. Representative of San Diego, who while in office acquired the 34-ton motoryacht *Duke Stir*. To quote from the newspapers of the day, "On November 28, 2005, Cunningham pled guilty to tax evasion, conspiracy to commit bribery, mail fraud and



**Kerry and Cunningham, Democrat and Republican. Truly paragons of public service.**

wire fraud in federal court in San Diego. Among the many bribes Cunningham admitted receiving were the house sale at an inflated price, the free use of the yacht, a used Rolls-Royce, antique furniture, Persian rugs, jewelry, and a \$2,000 contribution for his daughter's college graduation party. With the plea bargain, Cunningham faced a maximum of 10 years. Had he fought the charges, he risked spending the rest of his life in prison."

In February of '06, Senator John Kerry introduced a bill, the Federal Pension Forfeiture Act, nicknamed the 'Duke



**WHEN IT'S TIME  
TO HAUL OUT,  
WE KNOW YOU  
HAVE A CHOICE.**

**HERE'S WHY YOU SHOULD CHOOSE BAY MARINE BOATWORKS.**

Of course, when it comes to getting your boat hauled out for repairs, there are more than a few boatyard choices in the Bay Area. However, as many sailors have discovered, there is only one boatyard that can conduct quality repairs at the right price, with no nasty surprises when it comes time to pay the bill – Bay Marine Boatworks. We can guarantee up-front pricing for our customers because we're a full-service boatyard in the full sense of the word. Which means we offer a full range of services for all types of sailboats, and solutions for all kinds of customers.

So call us today for details about our current promotion, and you'll discover that your best choice is to haul your sailboat out at Bay Marine, the sailor's boatyard.

- Collision Repair Work
- Fiberglass, Gelcoat & Painting
- Mast Stepping Rigging Work Mast Tuning
- Thru-hulls and Valves
- Drivelines and Engine Service
- Woodwork
- Welding & Metal Fabrication
- Electrical & Plumbing
- Sandblasting



310 W. Cutting Blvd.  
Pt. Richmond, Ca  
1-800-900-6646  
1-510-237-0140



*The Sailor's Boatyard*

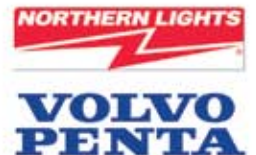

[www.baymarineboatworks.com](http://www.baymarineboatworks.com)



**South Beach Harbor is a great way to experience San Francisco. Boats of all sizes are welcome in our protected deepwater harbor. Bring your boat to South Beach and enjoy all the attractions of the city.**



- Two guest docks for boats up to 125'**
- 20 guest berths up to 50'**
- Casual and fine dining nearby**
- Adjacent to AT&T Park**
- Easy access to transportation**
- 24 hour security**
- Free pump-out stations**



**For Reservations:**  
 415.495.4911 (x0)  
 fax: 415.512.1351  
 sb.harbor@sfgov.org  
 www.southbeachharbor.com

# LETTERS

Cunningham Act', to prevent lawmakers who have been convicted of official misconduct from collecting taxpayer-funded pensions.

Jim Cooper  
 Kayaker  
 San Francisco

*Jim — Thank you for coming up with the specific example on the Republican side. But isn't there laugh-out-loud irony in John Kerry standing in judgment of another elected official, and then, despite being the richest man in the U.S. Senate, trying to stiff his own constituents out of half a million in taxes? As we said before, a pox on those on both sides of the aisle. The only mystery to us is how long it's going to be before the younger generations — who are the ones who are really going to get screwed — start sharpening the pikes and erecting guillotines.*

⇓ **MISSING DIGIT CLUB NOMINEE: JERRY GARCIA**

I'm not applying for *Latitude's* 'Missing Digit Club'; I'm nominating. Although he doesn't — or rather, didn't — sail, I'd like to nominate Jerry Garcia of the Grateful Dead. As some readers may know, he lost the middle finger of his right hand when he was four when his brother accidentally cut it off while



***Jerry's custom 3.5-finger guitar pick, symbolic of his membership in the missing digit club.***

chopping wood. Speaking as a sailor, I've found Garcia's music to be inspirational, entertaining and even informative. And he did some wonderful, nautically themed songs in the genre of old sea chanties on his collaborative CD with David Grisman called *Shady Grove*.

As an aside, I used *Ripple* as the first song in the soundtrack to the one-hour video I made of my '07 Ha-Ha adventure. (I'm still working on the video for my '09 Ha-Ha sail.) If all goes well, it won't be long before you'll be seeing my sailboat, *Sugar Magnolia*, sailing around the Bay — hopefully someday with a spinnaker carrying the Dead's SYF logo. I'd name my boat *China Cat Sunflower*, but I'm a monohull kind of guy.

Steve Hajnal  
 Sugar Magnolia, Kalik 33  
 Bay Area

*Steve — Ol' Jerry used to sometimes block the driveway at the Latitude office in Mill Valley with his big BMW while he got treatment from the chiropractor next door. Once we saw him around the corner at the 7-Eleven, hunched over to be inconspicuous while furtively grabbing a couple of fistfuls of candy bars. It just happened to be when he was on the front cover of Rolling Stone for the last time, and a bunch of hippie kids ran up to him and asked in disbelief, "Jerry, Jerry, is that you?" It made them realize that people don't look anything like they do glossed up on the covers of slick magazines.*

*There's a sailing angle to all this. Shady Grove was also the name of a fine album by the Grateful Dead's San Francisco contemporaries, Quicksilver Messenger Service, one of our favorite groups of the era. Another Hit Of Fresh Air, anyone? Quicksilver was headed by the charismatic Dino Valente, who after living on a houseboat on Richardson Bay, got flush and bought the*

*Come Visit Us Today!*

# SOUTH BEACH SAILING CENTER

at the  
beautifully renovated Pier 40 in San Francisco

## October To-Do List

*It's easy as 1-2-3*

- 1. Call Liz about new cushions*
- 2. Choose your style*
- 3. Go sailing!*

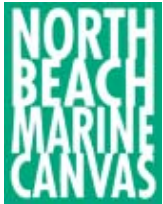

**415.543.1887**

**nbmc@earthlink.net**  
**www.northbeachmarinecanvas.com**  
**Pier 40, The Embarcadero**  
**South Beach Harbor, San Francisco**



## South Beach Riggers

**Winning  
Technology for  
the Hot Race or  
the Casual Cruise**

- Expert advice, sales and splicing of Vectran, Spectra, Technora, and Dacron by our certified splicer
- Professional survey and tune for your rig
- Standing and running rigging replacement
- Fabrication and hydraulics
- More than 100,000 miles racing and cruising experience



### TWO LOCATIONS

**399 Harbor Dr. • Clipper Marina • Sausalito • 415.331.3400**  
**Pier 40 • South Beach Harbor • San Francisco • 415.974.6063**

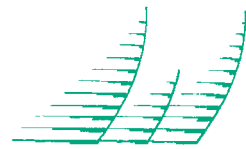

## Westwind

**Complete Yacht Care**

*Serving the entire Bay Area  
for more than 20 years*



*"Thanks Mike! Your team did an outstanding job on our boat. Can't remember it ever looking better. Thanks for your help."*

*- Marty Roher,  
Beneteau 36*



**(415) 661-2205**

Pier 40, South Beach on the Embarcadero • San Francisco

Call Toll Free **888-828-6789**



westwinddetailing@sonic.net  
**www.boatdetailing.com**



**Adjacent to South Beach Harbor and AT&T Park • Close to dozens of fantastic restaurants and shops**

# BLUE WATER YACHT INSURANCE

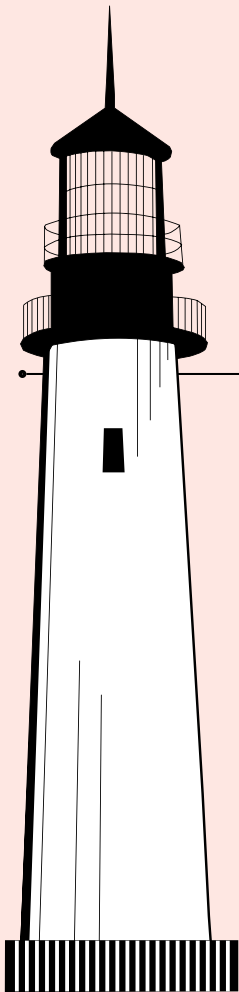

Blue Water Yacht Insurance covers more active cruising boats than any other marine agency in the Western Hemisphere, and is the leading innovator of insurance products for the offshore sailor.

## Our Insurance Programs Provide:

- Crew of two anywhere
- Worldwide Navigation
- Hawaii
- Caribbean
- South Pacific
- Mexico
- Charter Boats
- Multihulls
- Liveboards
- Racing Boats

## Quality Rated Insurance Companies

Boats aged 1 to 40 years • "Agreed Value"  
"All Risks" • "New for Old" replacement partial losses  
Hulls valued \$50,000 to \$2,500,000

## Worldwide Health Insurance

International and USA health insurance plans  
at affordable prices.



BLUE WATER  
INSURANCE  
JUPITER, FLORIDA • USA

Call Toll Free  
**(866) 463-0167**  
Fax: (866) 795-3707  
sales@bluewaterinsurance.com

Quote requests  
Visit our website

[www.bluewaterinsurance.com](http://www.bluewaterinsurance.com)

## LETTERS

65-ft schooner Brigadoon. The historic first design of L. Francis Herreshoff. Brigadoon was built on the East Coast in '24, sailed to the West Coast in the '40s by actor Sterling Hayden, and is now owned by former St. Francis YC Commodore Terry Klaus and his wife Patti. In fact, the Alameda-based Brigadoon



Dino had a vision . . .

was featured on page 89 of the July Latitude. Valente was the genuine mid-'60s San Francisco psychedelic rock 'n' roll article, as evidenced by fellow band member John Cipollina recalling how Quicksilver came together:

"It was Valente who organized the group. I can remember everything Dino said. We were all going to have wireless guitars. We were



LATITUDE / JR

. . . but it didn't always include taking care of the great schooner 'Brigadoon'.

real short dresses on, and they were gonna have tambourines with silver coins as the clappers. And I'm sitting there going, 'This guy is gonna happen, and we're gonna set the world on its ear.'"

The rock 'n roll lifestyle and maintaining wooden boats aren't always compatible, so it didn't surprise us when Klaus told us that Bridadoon wasn't in the best of condition when he purchased her from Valente in '76. But that's rock 'n' roll and old wooden schooners for ya!

## THE STATE COULDN'T SELL SHAVE ICE IN HELL

During the late '60s and early '70s, I was a member of Donald Wolbrink & Associates, a private consultant planning team that did a Master Plan for the expansion of the Ala Wai Harbor in Honolulu. As I remember, we were able to potentially increase the number of boats in the harbor by about 50%. As far as I know, the state never did implement the plan.

At one time, the state was interested in bringing people from the airport to the Ala Wai via commercial hydrofoil, hovercraft or fast cat boats. That plan did not go through because there was not enough vehicular access for emergencies or for the vehicles that would pick up the passengers. There probably still isn't enough access or room.

Another challenge the Ala Wai had was the amount of trash that comes down the Ala Wai Canal and into the harbor. When I lived on Oahu, the state had a trash intercepting facility right where the Canal entered the harbor.

When I lived in Hawaii, I remember that you could get a slip in the harbor for about \$2 or \$2.50/ft. That was the best deal in town at a 'primo' location. As a consequence, there were many two- and three-story high plywood 'junkers' in the harbor that were causing problems. The state later passed a rule requiring every boat in the marina to prove she could, under her own power, go out to a buoy that was about a mile away from the harbor and come back again. Boats that didn't pass the test had to be removed. This is when the fun began,





# Learning by doing...

Take your sailing to the next level!

*Alaska Eagle* is the perfect offshore sailing platform. Built for the Whitbread Round the World Race, she has proven her mettle over the past 28 years Orange Coast College has operated her. On all of our passages you will be intimately involved with the daily running of the boat, learning by doing. Sail changes, standing watch, steering in the calms and gales, *Alaska Eagle* voyages are for those who want to be involved.

## Easter Island - Puerto Montt - Nov 24 - Dec 13, 2010

**FEATURED LEG** Famous for Polynesian culture and giant Moai statues, Easter Island is a place most sailors only dream about. Sailing from the open anchorage, *Eagle* will head toward Puerto Montt, "the Gateway to Patagonia." The Humbolt current and weather systems will dictate the route *Alaska Eagle* will take as she moves toward the South American mainland and some remote little coves.



## Antigua - Panama Canal - May 3 - 20, 2011

**JUST ADDED** Naval history, white sand beaches and beautiful private yachts may entice you to arrive early for this leg. Once onboard, robust downwind sailing will be punctuated with stops as we head toward the Panama Canal. Going through the canal is, of course, the icing on the cake.

For an application or information on all our Adventure Sailing Voyages, look for *Alaska Eagle* at: **occsailing.com** or email: **karen@occsailing.com** or call **949-645-9412**.

The School of   
**SAILING & SEAMANSHIP**  
 \ Orange Coast College



### ADDITIONAL LEGS

- Newport Beach - Easter Island . . . . . Oct 30 - Nov 23, 2010
- Easter Island - Puerto Montt. . . . . Nov 24 - Dec 13, 2010
- Puerto Montt - Ushuaia . . . . . Dec 19 - Jan 11, 2011
- Ushuaia - S. Georgia - Buenos Aires . . . Feb 4 - Mar 7, 2011
- Buenos Aires - Rio de Janeiro . . . . . Mar 14 - Mar 28, 2011
- Rio - Antigua . . . . . Apr 1 - Apr 29, 2011
- Antigua - Panama . . . . . May 3 - May 20, 2011

**UNSURPASSED FACILITIES**

Ultra-wide slips and innovative concrete docks with round fingers. Beautiful restrooms and showers. Plenty of parking.



**CONVENIENCE**

All slips feature double 50-amp 125/250V power, free dock box, DSL phone line, and pumpout connections. Parking, WiFi and ice are complimentary.



**LOCATION**

Located in the heart of Silicon Valley, Westpoint Harbor is close to San Francisco and San Jose airports, and minutes from historic downtown Redwood City. At 50 acres, Westpoint enjoys more than 300 sunny days per year and is one of the largest recreational harbors in Northern California, with 12 feet of depth (MW).



"We race or go on a club cruise—out almost every week, so we needed a marina that was close to home and work. The great docks, amazing new facilities, warm weather and friendly and fun community made it a no-brainer: we are extremely happy with our choice of Westpoint Harbor." — Kathryn & Robin Weber, Catalina 375 Agave, Sequoia YC



[www.westpointharbor.com](http://www.westpointharbor.com)

650 224-3250

1529 Seaport Blvd., Redwood City, CA 94063

**LETTERS**

as many boats didn't have engines, and some that weren't really boats fell apart in the Travel-Lift slings before they could even be swung over land.

Unfortunately, the Ala Wai Harbor Master Plan was just one of many plans and studies that the people paid for but the state never implemented. We did a master plan for a new harbor in the area off Hawaii Kai, but that never happened either. We also did the state's five-year Statewide Comprehensive Outdoor Recreation Plan (SCORP), but I'm not sure if it was ever utilized.

Roger DeWeese  
Del Mar

Roger — A 10-year-old could have shown Hawaii state officials how to double the number of slips at the Ala Wai, which — duh — would have more than doubled the marina's revenue. Mind you, this was at a time when there was a 10- to 20-year waiting list for slips in that harbor and, as you pointed out, the state was charging some of the lowest slip rates in the country.

While there has been some improvement in utilization of space at the Ala Wai in the last 30 years, there is still room



LATITUDE / RICHARD

for much more. After all, there are still dozens of 30-ft boats in spaces that could easily accommodate 60- to 100-ft boats. It's as if the State of Hawaii is a farmer who owns 100 acres of the most fertile acreage in the world, but because he is stupid and/or lazy, lets 50% lie fallow.

**The mysteries of the Ala Wai include putting 30-ft boats in spaces that could accommodate 100-footers, and not cleaning up trash.**

It wouldn't be so bad, but the 'farmer' is working on behalf of taxpayers and boatowners.

The problem of trash floating down the Ala Wai Canal and into Ala Wai Yacht Harbor, or blowing into the harbor from adjacent streets, is a serious one. Because of wind and current, much of it collects in the southeast corner of the Ala Wai adjacent to Holomoana St. behind the Ilikai Hotel. Question: How hard would it be for a harbor employee to swing by that spot twice a day with a net on a pole and spend 20 minutes fishing the unsightly crap out of the water — as is done at other harbors around the world with even less of a problem? Answer: To our thinking, it wouldn't be hard at all.

**↑ ↓ CHARTERING FOR ANTIGUA SAILING WEEK**

My husband and I are longtime readers and admirers of Latitude. We sold our 44-ft Peterson in '08, and miss her every day. But we've decided to take a large group to Antigua Sailing Week for the first time next year, and would like your advice on the following:

- 1) What is the best type of boat to charter for us to view the races? And to participate in local, small-time races?
- 2) Do you have a recommendation for a charter company in Antigua? We are getting wild quotes of \$5,000/week. Is that considered reasonable?
- 3) Anything else you would like to recommend to us as first-timers?

My email address is [amcenany@yahoo.com](mailto:amcenany@yahoo.com) in case any charter captains can get in touch with us.

Anne McEnany  
Washington D.C.

# Been there, done that!

## So let us help you to get set for the Baja Ha-Ha!

Our friendly, knowledgeable Associates are ready to help you with all of your outfitting needs!



### **Bellevue, WA – Mike Griffith**

**13211 Northup Wy. • (425) 641-4065**

Mike has 60,000+ miles cruising experience in the South Pacific, Hawaii, West Coast, Canada and Alaska. Many of those miles were singlehanded. He is a former sailing instructor. He has owned and upgraded the same C&C 38 for over 30 years.



### **Sausalito – David Forbes**

**295 Harbor Dr. • (415) 332-0202**

In addition to teaching all levels of boating, David has captained various vessels from 40'-80' throughout the Caribbean, New England, Mediterranean, and Eastern Pacific. He currently owns a Colgate 26 and is active in the SF Bay Area Racing community.



### **Alameda – Dan Niessen**

**730 Buena Vista Ave. • (510) 521-4865**

Dan Niessen currently owns two boats and is an avid long distance cruiser and a certified sailing instructor.



### **Long Beach – Holly Scott**

**251 Marina Dr. • (562) 598-9400**

Captain Holly has been sailing all her life and has done so all over the world. She currently holds a 100-ton Masters License and loves to share her knowledge, experience and boating humor.



### **Newport Beach – Tom Stallings**

**900 West Coast Hwy. • (949) 645-1711**

Tom Stallings has over 35 years of boating experience and is a current Dana Point liveaboard. Along with his thousands of ocean miles, Tom is a licensed U.S. Merchant Marine Officer and U.S.C.G. Master.



### **San Diego – Louis Holmes**

**1250 Rosecrans Dr. • (619) 225-8844**

Louis has been an avid sailor for 22 years. He has over 6,000 miles of delivery experience, including two Mexico returns and a return from Hawaii, and over 10,000 miles of racing experience.

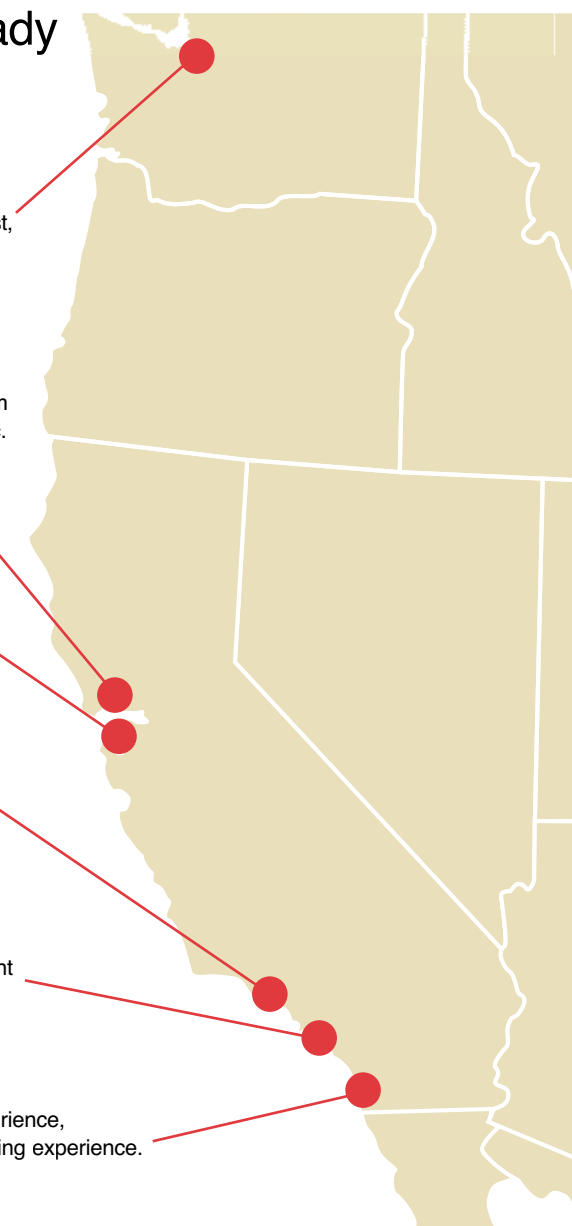

Over 300 stores nationwide!  
For the location nearest you,  
go to [westmarine.com](http://westmarine.com)

 **West Marine®**

# SHAFT SHARK

**The best rope,  
line and debris  
cutter there is!**

Two piece unit

For both power and sail

**Now available for  
sail drive systems.**



747 Aquidneck Ave.  
Middletown, RI 02842

**401-847-7960**

Fax: 401-849-0631

sales@ab-marine.com

[www.ab-marine.com](http://www.ab-marine.com)



# Gori propeller

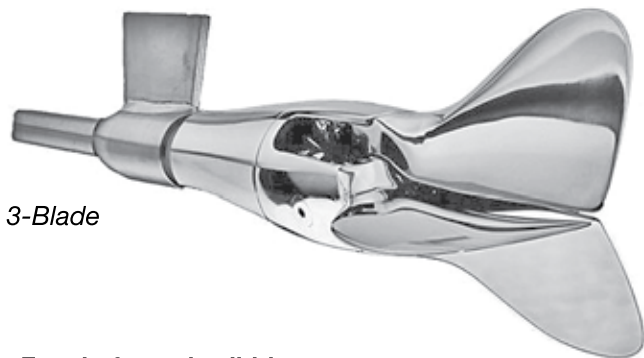

3-Blade

- For shafts and saildrives
- Both 2 & 3 blade available
- Lowest drag when sailing
- The champions choice



747 Aquidneck Ave.  
Middletown, RI 02842

**401-847-7960**

Fax: 401-849-0631

sales@ab-marine.com

[www.ab-marine.com](http://www.ab-marine.com)

**CALL US TODAY!**

**800-801-8922**

## LETTERS

Anne — If you're going to have a large group, which we'll assume is eight to 10 people, and you're going to want to watch the races, we recommend a catamaran. She'll have the room you need, plus a nicer motion in the considerable fleet slop off English Harbor's Pillars of Hercules, which is where you can best view the races. When it comes to local, casual races, it's going to be a problem because you probably won't be able to get insurance for that, and in any event those races tend to be cancelled during sailing week.

We did six Antigua Sailing Weeks with our Ocean 71 Big O — back when they were a full week instead of the upcoming April 24-29 version — and they were some of the highlights of our life. So if enough members of your group are enthusiastic sailors, we suggest that you charter a boat with the provision for racing in the event. No worries, as many sailors in the charter divisions aren't hot-shot racers, and you can skip a race or two if you want but still be part of all the festivities. But check with the Antigua Sailing Week website for details, as they are making changes to the event this year to make it more enjoyable for everyone, from the charterboat folks to the grand prix racers.

As wonderful as Antigua Sailing Week is, and as wild as the parties are — or at least used to be — we wonder if you wouldn't enjoy the Antigua Classic Regatta more. It's also based out of English and Falmouth Harbors, and will run from April



**If this is the kind of boat you'd like to see, we'd recommend that Classic or the Voiles.**

15-20. The event features traditional and 'spirit of tradition' boats from 26 to 155 feet. The boats are spectacularly beautiful — and even more breathtaking than modern racing machines when under sail. In addition to the racing, there is a Concours d'Elegance, a Music Night, a Classic Yacht Parade through the harbor, and, of course, Afternoon Gig Racing and a Cream Tea Party before the final night prize-giving. There are also many opportunities to crew. If you're more boat voyeurs than hard core racers, we'd recommend the Classic Regatta.

Another event you might want to consider is the St. Barth Bucket, March 24-27, which features 40 modern and classic megayachts of at least 100 feet in length. Captains of Industry, who aren't used to being told 'no', battle each other just to get a slot in the prestigious event so they can get a chance to battle each other on the water. Although it's fun rather than hard core racing, top crew are flown in from around the world, and the tiny harbor at Gustavia is cleared so the huge boats can be Med-tied on the quay for all to see. It's quite a sight and quite the scene. The viewing opportunities are excellent, and once the racing is over, it's only a few miles to the quiet beauty of the anchorages at Columbie, Baie St. Jean, Ile Foursche, Gouverneur's and Grand Saline. If you wanted see this event, you would charter out of St. Martin.

We have our '00 Leopard 45 catamaran 'ti Profligate in yacht management with BVI Yacht Charters, which is in the 'secondary' market, as opposed to The Moorings and Sunsail.



# Paradise Village™ MARINA

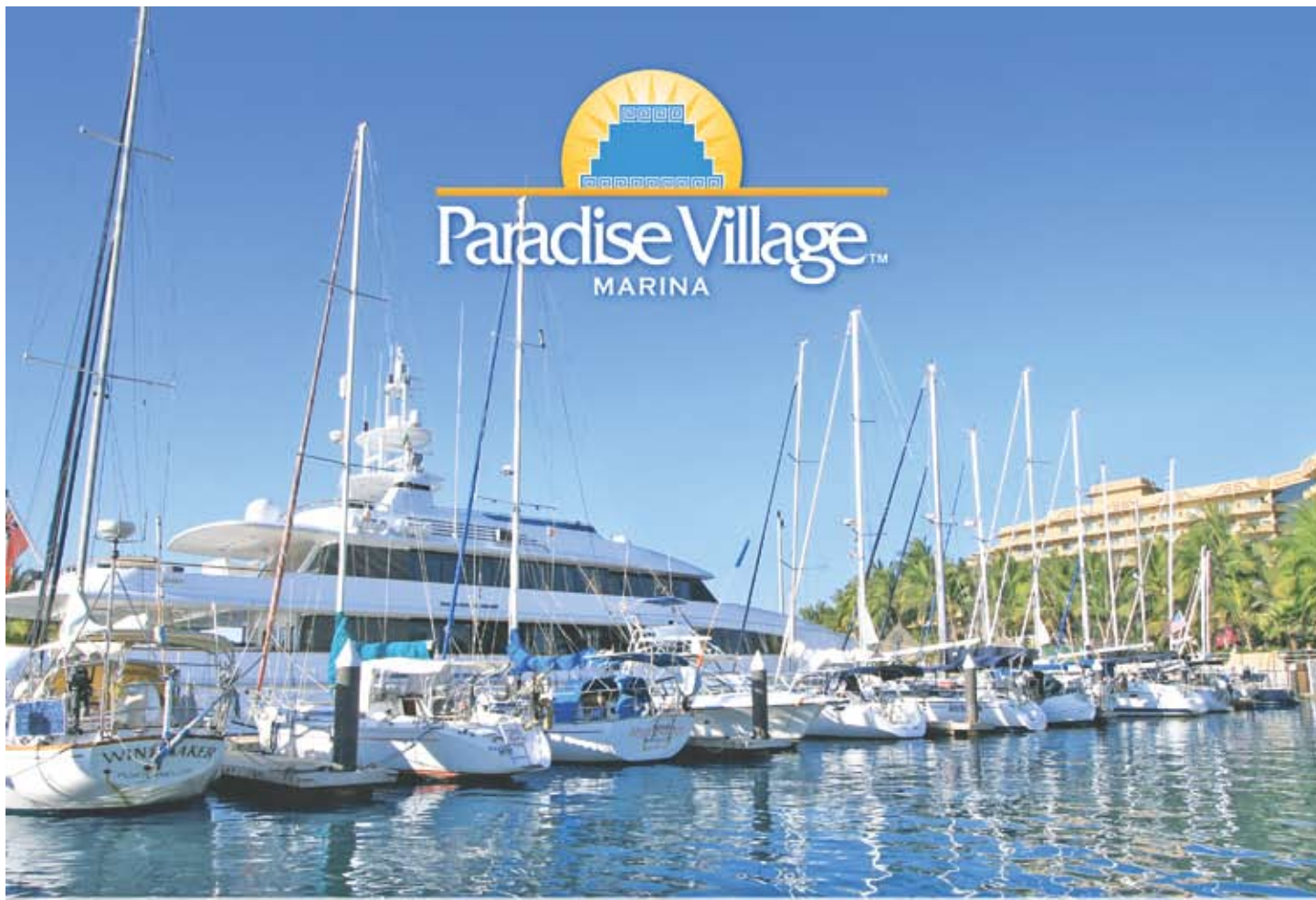

*Voted best Marina in Mexico*

## *Services:*

- Electrical service, 110/30 amps
- 220/50 amps, 3 phase 100 amps and 3 phase 480v
- Crystal Clear Potable Water
- Cable TV
- Garbage Collection
- Pump - out Station
- Fire Fighting Boat Protection
- 24 Hrs. Security
- Computerized gate access

## *Additional Services:*

- Vallarta Yacht Club
- Special area for marina guests
- Restrooms
- Lockers
- Showers
- Pool and jacuzzi
- Free access to all the facilities of our 5 star hotel
- White sand beach
- Dive tank refilled
- Propane refill
- Launch ramp

*World Class Marina*  
[www.paradisevillage.com](http://www.paradisevillage.com)



CONTACT US: [marina@paradisevillagegroup.com](mailto:marina@paradisevillagegroup.com)  
Phone & fax from U.S. 011-52-322-22-66728 · GPS Coordinates: 105° 17.9 W 20° 41.2 N



Vallarta Yacht Club

"CALL TODAY  
AND START  
ENJOYING YOUR  
BOAT AGAIN.  
WE WORK SO  
YOU CAN PLAY."



## BAY AREA BOAT WORKS



FULL SERVICE SHOP WITH DOCK ACCESS

- Offering Custom Hard Tops
- Maintenance Programs
- Mobile Service – We bring the boatyard to you
- Boat and Trailer Storage Available
- We Do It All – From Repowers to Custom Enclosures and Everything in Between

CALL TODAY AND  
START TO PLAY



## BAY AREA BOAT WORKS

25 THIRD STREET, SAN RAFAEL

(415) 454-BOAT (2628)

LICENSED & INSURED

[www.BayAreaBoatWorks.com](http://www.BayAreaBoatWorks.com)

## LETTERS

*Our cat, which sleeps eight, is a very busy little girl at \$5,500 to \$6,500 a week depending on the season, which will give some indication of the going rate in the secondary market. (By the way, some sailing magazines are asking \$4,100 for just one of the four cabins on their bareboat flotilla boats. Ouch!) You can also get a monohull that sleeps 10 for about the same price as 'ti Profligate.*

*No matter what event or boat you might chose, we think you'll have a great time.*

### ↑↓ JESSICA WATSON'S HUMBLE NATURE

I'm a recreational sailor on the Chesapeake Bay who recently had the opportunity to meet Jessica Watson, the Aussie teen who earlier in the year became the youngest sailor to complete a singlehanded non-stop circumnavigation via the Southern Ocean. She's an incredible person.

I started following Jessica's blog right after she had the collision with the ship during her trial run from the Sunshine Coast to Sydney. I was so impressed with the way she handled the criticism of her voyage that I promised I would make a comment and follow her as she sailed around the world. While I was doing this, a virtual community — we called ourselves 'Jess-oholics' — formed and became quite close.

One of the Jess-oholics made arrangements with her manager so we could have a private dinner with her while she was in New York City in early September to promote *True Spirit*, her new book, on television and with other media. There were 14 people at the dinner, including people who had flown in from Washington, Oklahoma, Georgia and other states. Jess was very gracious, and I was immediately impressed with her humble nature and good humor. On several occasions people told her that she had inspired them. Jess would reply by saying, "I'm going to have to talk to my brother, Tom, so that he can get my head back to size". Or, "If you really got to know me, you wouldn't think I'm so special."

This from a young woman who had just been on *Fox and Friends* and the *CBS Morning Show*, has the best selling book in Australia, is the ambassador for Perth 2011 Sailing, is Queensland's Ambassador for Tourism, has an exclusive contract with News Corp., and has just sailed around the world — solo, nonstop, and unassisted — at 16 years of age! By the way, she confirmed that her circumnavigation was entirely her idea, that she'd planned it for years, and she'd been the driving force behind it. There is a two-hour documentary of her adventure, narrated by Sir Richard Branson, that will be released soon.

The launch of Jess's book and the telling of her amazing voyage in the United States has been overshadowed, in my opinion, by what I believe was Abby Sunderland's hasty, poorly planned attempt to beat Jess's record, an attempt that ended when Sunderland had to be rescued in one of the most remote parts of the Southern Ocean. As I see it, the two attempts were as different as chalk and cheese. Jess's trip was a textbook example of how to do it. She had 10,000 miles of sailing experience before she left; her boat was the right boat; and she had been meticulously prepared. Yet it's been Abby's failed attempt that got all the publicity.

Jess was at the Long Beach Boat Show in early September. I hope lots of *Latitude* readers were able to meet her, as she has a special charismatic quality.

Richard Weills  
Shaba, Sabre 28  
Bowie, Maryland

*Richard — Not to detract from Watson's admittedly outstand-*

# Yacht owners trust **PACIFIC CREST CANVAS** for the best in design, service and quality.

## Still the Highest Quality Products at the Best Prices

- **Offshore Dodger™**

Welded aft handrail  
Bolt-on side handrails  
Lexan windshields

- **Baja Awning™**

Lightweight and waterproof  
Durable and easy to launch  
Multiple side screen configurations

- **Coastal Dodger™**

Affordable designs  
Same high quality materials  
Same superior workmanship

- **Cruiser's Awning™**

Easy setup off your dodger  
Flies with no bulky frame  
Comes with shade screens



Tom Knapp with his new Offshore Dodger on his new Catalina.

Open Monday-Friday 8:00-4:00  
Saturday by appointment  
**(510) 521-1938**



2021 Alaska Packer Place  
Alameda, CA 94501  
Grand Marina

[www.pacificcrestcanvas.com](http://www.pacificcrestcanvas.com)



**SEE US AT THE ANnapolis BOAT SHOW BOOTH C-65**

FREE QUOTES

**10,000 SAILS IN STOCK**

[www.BaconSails.com](http://www.BaconSails.com)

Search online – list updated daily

**BACON SAILS AND MARINE SUPPLIES**

116 Legion Avenue Annapolis MD 21401  
**(410) 263-4880**

## HANSEN RIGGING

RIG SHOP • 510.521.7027



**WINTER RE-RIG?**  
Now is the time to plan ahead!



Check our inventory of high performance line.

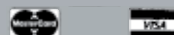

2307 Blanding Avenue, Suite G  
Alameda, CA 94501

[www.hansenrigging.com](http://www.hansenrigging.com)



**West Marine®  
Rigging Service**

# Your Sailing Resource!

Specialty Hardware • Technical Apparel

Visit [westmarine.com](http://westmarine.com) to shop our **New One Design** offerings



**Mobile Rigging Service Available**

**Complete Rigging Headquarters!**  
Installation • Lifelines • Running Rigging  
Standing Rigging • Dock & Anchor Lines

**SCHAEFER MARINE**

**FSE ROBLINE**  
WORLD CLASS YACHTING ROPES

**RONSTAN**

**POWERLITE**  
FIBER RIGGING

**Johnson**  
Marine Hardware

**NEW ENGLAND ROPES**  
TOGETHER IN MOTION

**SAMSON**

**facnor**  
FURLING SYSTEMS

**Hayn Marine**

**holmatro**  
marine equipment

**SmartRigging**  
The Intelligent Choice

**HARKEN**

**FORESPAR**

Contact us for all of your Rigging Needs!

**888-447-RIGG**

or visit our Onsite Rigging Locations in:

**Alameda, CA**

**San Diego, CA**

**Seattle, WA**

730 Buena Vista Ave.  
(510) 521-4865

1250 Rosecrans St.  
(619) 255-8844

1275 Westlake Ave. N  
(206) 926-0361

[westmarine.com/rigging](http://westmarine.com/rigging)

## LETTERS

ing achievement, but as we've stated before, we, along with all other sailing authorities, are against the concept of age-based sailing records. We feel even more strongly about it now that it's been demonstrated that there can be a such a large payday at the end — even for those who fail. Indeed, one of the most macabre aspects of the whole business is that the parents of the first youth who dies, particularly if in an agonizing way, will probably profit the most. So good on Jess, but to hell with the concept of age-based sailing records.

### ↑↓ **THANK YOU FOR YOUR SERVICE, McALEX!**

I just want to thank you and everyone at *Latitude* for everything you do. I have a boat in Sausalito — fortunately my best friends are watching over her — but I am currently deployed to Afghanistan to help civilians on the battlefield. A really good friend of mine sends me *Latitude* every month, and it's awesome to put on some music, read *Latitude*, and pretend



ALEX PEARCE

I'm back in the Bay! In fact, I just received the new *Latitude* today and I'm pumped to read it. I've also convinced one of my Army buddies, Michah Tudor, to move to Sausalito and buy a boat, so he's reading all the *Classy Classifieds*, and asking me a lot of questions about all the makes and models.

Anyway, add Afghanistan to the list of 'weird places where *Latitude 38* is read!

Sgt. Michael Alex 'McAlex' Pearce  
Shrimp Louie, Cal 29  
Sausalito / Afghanistan

**McAlex's friend Michah stows 'Latitude' in a leg pocket when he goes out on missions in Afghanistan. See you soon, boys!**

through the magazine. By the way, readers may remember you from a profile we did on you in the February issue, shortly before you shipped off.

We don't know about anyone else, but we'd like to see Americans start driving 74-mpg diesel vehicles so this country can become as energy independent as possible and bring all our fine young men and women — and money — back from the sands of the Middle East.

### ↑↓ **READY AND WILLING TO CREW FOR PIRATES**

My wife and I are very interested in participating as crew in the Pirates for Pupils event on Banderas Bay. We have attended the Banderas Bay Regatta twice, but won't be able to attend next spring because of a conflict.

Our plans are to purchase a 45-ft boat and move her to the Vallarta YC in two years, then live aboard for five months a year. We really like the Vallarta YC community and are looking forward to becoming part of the family.

Stephen W. Dale  
Playpen 2, Hunter 320  
Oakland YC  
[www.playpen2.com](http://www.playpen2.com)

Stephen — The Pirates for Pupils Spinnaker Run for Charity is the last day of the Banderas Bay Blast, which this year will be held December 1-3, ending at Paradise Marina the day



**Celebrate the Boating Lifestyle!**



Discover

Brisbane  
Marina



From Hwy 101, take the Sierra Point Pkwy exit and follow the signs to the marina.

400 Sierra Point Parkway  
Brisbane, CA 94005

**(650) 583-6975**

[www.ci.brisbane.ca.us](http://www.ci.brisbane.ca.us)

[harbormaster@ci.brisbane.ca.us](mailto:harbormaster@ci.brisbane.ca.us)

**GREAT LOCATION!** Just minutes to Central Bay sailing.

**GREAT RATES!** Starting at \$5.90/foot!

**MARINA GREEN** with picnic/BBQ areas, Bay Trail Access and FREE Wi-Fi.

**HOME OF THE  
SIERRA POINT YACHT CLUB**



**Harbor 25**



**HARBOR 25**

Enjoy Sailing in Style and Comfort

The Harbor 25 is a stunning design with classic looks, a roomy cockpit, beautiful interior, inboard engine, and self-tacking roller furling jib.

**Harbor 20**



**HARBOR 20**

The Boat that Brings Fun Back to Sailing

With its huge cockpit, a self-tacking jib, a roller furler, and an electric motor, the Harbor 20 is the perfect daysailer.

In Marina del Rey:  
**THE YACHT EXCHANGE**  
310.305.9192

**W.D. Schock CORP.**

Est. 1946

[www.wdschock.com](http://www.wdschock.com)

In Sacramento:  
**INLAND SAILING CO.**  
916.859.3436

# SEA FROST®



## COOL IT YOURSELF!

Refrigeration has never been easier. Sea Frost's compact and powerful, 12-volt BD refrigeration conversion kit comes pre-charged and ready for owner installation.

**Sea Frost...Quality at an affordable price!**

### Local Dealers:

Anderson Refrigeration Co. • Alameda, CA  
(510) 521-3111

Pooler Refrigeration Service • Alameda, CA  
(510) 523-3495

**www.seafrost.com**

## LETTERS

before the Vallarta YC's huge annual Cruisers' Chili Cook-Off for Charity.

The Banderas Bay Blast is a joint effort of the Punta Mita Yacht & Surf Club and the Vallarta YC, and features 'absolutely nothing serious' cruiser-style racing. Race one is from either Paradise Marina to La Cruz or from Punta Mita to La Cruz, whichever the boatowner wants to do. Race two is from La Cruz to Punta Mita. Race three, which is also the Pirates for Pupils, is the 12-mile spinnaker run from Punta Mita to Paradise Marina. It's all lovely, moderate-breeze, flat-water sailing in the tropics.



**Anyone for flat-water sailing in the tropics?**

But there's much more to the Blast, including the annual costume-party opening of the Punta Mita Y&SC, plus maybe a cruiser surf contest, the big water balloon drop from the Sky Bar at the Riviera Nayarit Marina, the Blast Night at Philo's, and we can't remember what else. Oh yeah, new this year is a hot tub stuffing at the big hot tub beneath the Vallarta YC.

The best way to get a ride in the Blast is to put your name out — as you have done — or to just show up ready to sail. With the help of sailmaker Mike Danielson of the Vallarta YC and his loft in La Cruz, you and your wife are certain to be able to get a spot on one of the 30 or so participating cruising boats.

↑↓ **WHERE'S THE OUTRAGE?**  
How come no outrage from Latitude regarding the Coast Guard's having to rescue John Innes and his Catalina 27 Amica off Fort Bragg? Singlehanded a small boat in those conditions should be sufficient fodder for you folks to condemn his stupidity much as you did with Abby Sunderland. Just a thought.

Orlando Duran  
San Francisco

Orlando — That's a fair question. Our thoughts are that there are some major differences: 1) Innes is a 29-year-old adult, not a 16-year-old. 2) Innes put his own money on the line, and was mature enough to use some of his limited resources intelligently — such as to buy a survival suit. 3) Innes spent three years personally upgrading nearly every bit of his boat rather than having hired hands try to do it in a couple of weeks. 4) Innes actively responded to the rough weather in the best way possible, by heaving to and setting a parachute anchor. 5) Innes was sailing on his own rather than being constantly advised on what to do by a shore team. 6) Innes sailed a common cruising route during what is considered to be the proper season. 7) The Coast Guard only had to go 55 miles offshore to find Innes, and thus didn't require a government to spend hundreds of thousands dollars to charter a commercial airliner to find him. We won't even touch the question of motivation.

We suppose that some folks might point to the tragic death of 13-year-old motorcycle racer Peter Lenz, who was recently killed at the Indianapolis Speedway after falling off his bike and being struck by a motorcycle being driven by a 12-year-old, and say there is no difference between that and what the singlehanded teen circumnavigation aspirants are trying to do. We're not familiar enough with motorcycle racing to comment on the wisdom of youth races — apparently many top racers

## The Real Cordless Winch Handle

Designed For A Sailboat  
Lightweight: 6.4 lbs & Weather, Resistant!



Winner of 2010 NMMA Innovation Award

# WinchRite®

Visit us at: [www.sailology.com](http://www.sailology.com)

(888) 939-2455

[info@sailology.com](mailto:info@sailology.com)

See us in Annapolis! Oct 7-11 Booth H13

WinchRite® is a registered trademark of Sailology, LLC

# Own a dock on San Francisco Bay! Perfect Location - Great Investment

40' Monthly Rent \$352.00

EMERY COVE  
YACHT HARBOR

**BUY A SLIP** – Save money & earn equity! Save 1/3 of your rental cost. Enjoy big tax savings as a slip owner. Emery Cove Yacht Harbor is the only marina on the Bay with FEE SIMPLE (not a grounds lease) dockminium ownership.

**OR RENT A SLIP** – 35-60' slips, rates from \$8.80 to \$9.80.

**MARINA GUARD®** – Cutting edge electrical ground fault monitoring system.

**WIRELESS INTERNET** – Free

Mathiesen Marine  
Michael Wiest Yacht Sales  
Emeryville Yacht Club  
on premises



**CALL FOR A MARKETING PACKAGE • 510-428-0505**  
3300 Powell Street, Emeryville, CA 94608 • [www.emerycove.com](http://www.emerycove.com) • Email: [info@emerycove.com](mailto:info@emerycove.com)

**METTEC**  
TITANIUM FASTENERS & PRODUCTS

**IMPROVES BOAT SPEED**  
HALF THE WEIGHT OF STAINLESS STEEL

BY USING TITANIUM FASTENERS YOU OBTAIN THE FOLLOWING ADVANTAGES:

- Cheaper than stainless steel over time.
- Reduced boat displacement.
- Reduced tipping moment.
- Non corrosive - more corrosion resistant than stainless steel.
- Carbon fiber compatible.
- Durable and reusable.
- High strength levels - minimum ultimate tensile strength 130-190ksi.

Carson City Nevada, USA (775) 246-8200  
[WWW.METTEC.COM](http://WWW.METTEC.COM)

## Ballenger Spar Systems, Inc.

Custom Racing and Cruising Spars  
Expert Design and Consultation

- Carbon and Aluminum spars
- Rod and wire rigging
- Hi-tech and conventional halyards
- Spar kits, extrusion
- Repair and modification
- Custom fabrication, waterjet and CNC
- Hardware, sheaves, spreaders
- Bay Area pick-up and delivery
- **Discounts** on halyards, standing rigging, deck hardware, furlers, Navtec integral cylinders
- 35 years experience!

**Call about Carbon Spars.**  
Masts • Booms • Poles

[www.ballengerspars.com](http://www.ballengerspars.com)

831/763-1196  
831/763-1198 (fax)

The Best Marine Products from the World, for the USA.

# Worth Every Dollar

WE'LL BE THERE!

- Newport Int'l Boat Show
- Annapolis Sailboat/Powerboat Shows
- Ft. Lauderdale Int'l Boat Show

Stop by and say  
"AHOY!"

- Ultra Anchors
- Ultra Bow Rollers
- Quickline Flat Rope & Reel
- Ultra Swivels
- Ultra Trip Hooks
- Ultra Chain Grabs, Ultra Snubbers & Ultra Bridles



[www.UltraAnchors.us](http://www.UltraAnchors.us)  
8700 Warner Ave., Suite #110  
Fountain Valley, CA 92708  
sales@quickline.us • 714-843-6964



## McGinnis Insurance

Since 1972

Knowledge  Commitment  
Reliability  Service



*Large and small, we do them all!*

Call us at: **800-486-4008**

[mcginnisins@aol.com](mailto:mcginnisins@aol.com)

License #0570469

## LETTERS

started when they were five — but it should be noted that most motorcycle racing authorities don't let just anybody show up and race. They require an applicant to submit a resume demonstrating two years of riding experience, which must be verified. The applicant must also demonstrate competence to a senior rider. Furthermore, there are age limits on the size of bikes youths are permitted to race. In other words, while youth motorcycle racing is a potentially dangerous pursuit, it's done in a controlled environment where there are standards of participation for the safety of the rider and other competitors. There are similar experience standards for almost all singlehanded races, and it's our understanding that none of the teen circumnavigation aspirants would have even qualified for the Singlehanded TransPac.

By the way, we think your describing what Innes did as "stupidity" reflects much worse on you than it does him. We think Innes did everything right — including immediately thanking those who rescued him — and we look forward to his getting another boat and taking off again soon.

### ↑↓ FISHING LINE TROUBLES OFF BAJA

We had a major incident during last year's Ha-Ha that might be educational for folks headed south this year. Because of the relatively heavy weather forecast for the second and third days of the Ha-Ha, about half of the fleet followed the Grand Poobah's suggestion of taking shelter for the night at Bahia San Quintin.

The next morning we and everybody else continued on in 25-knot winds and 12- to 15-ft seas. But at 30° 06'N, 115° 59'W, which is approximately 15 miles SSE of San Quintin and about 10 miles offshore, the wing on the keel of our Hunter 410 snagged at roughly the midpoint of a 400-yard long piece of hook-laden, yellow 3/4-inch polypro line used for commercial fishing. Soon we found ourselves with the two ends trailing 200 yards behind our boat, dragging two large floats.

Because of the rough conditions and our being trapped on the line, we couldn't bring *Passage II* up into the wind to drop sail or reduce the pressure of the line on our keel. Because of the pressure of the boat on the line, we couldn't grapple it high enough to cut it. We were afraid to start the engine because of the possibility that the prop might also get caught in the line. Going into the water to cut the line would have been far too risky given the very rough conditions.

We were overtaken by a couple of other boats before *Profligate*, bringing up the rear of the boats that had spent the night in San Quintin, arrived and offered assistance. The big cat stayed with us as we made various unsuccessful attempts to get free of the line. Our sincere thanks to the experienced crew of *Profligate*, as given the rough conditions, it was an unbelievably good feeling to have them right there with us.

Ultimately, the Grand Poobah suggested that the best option was for us to head to the shelter at Punta Baja, an anchorage about 20 miles away, dragging the line behind us. Once in calmer waters, we could free our boat from the line. It was our only good option, so we took it, hoping for some luck along the way. The first luck we had was bad. Because of the drag from the line, it was extremely difficult to control our boat. So while going down the face of a wave, we accidentally jibed and broke some fittings at the gooseneck. Things had gone from bad to worse, so it was even more reassuring to have *Profligate* standing by.

But then we had some good luck. A huge following wave lifted our stern so high that the thick line fell off our keel! A cheer went up from *Profligate* when they heard the news. We

# WORLD'S #1 MAINSAIL FURLER

Leisure Furl In-Boom Furling Systems, Allow You To Easily Hoist or Reef from the Safety of the Cockpit.



See the Leisure Furl Advantage at the Annapolis Boat Show

- Elegant Tapered Styling
- 5 Year Limited Warranty
- Carbon or Aluminum



**FORESPAR**<sup>®</sup>  
**LEISURE FURL**

Tel: 949 858-8820 • [www.forespar.com](http://www.forespar.com)



OPTIMIZED FOR ENGINES UP TO **140 HP**

## Advanced blade design makes fixed props obsolete!

Introducing the world's first feathering prop to offer lower drag, higher efficiency, and fully adjustable forward and reverse pitch. Faster motoring and sailing speeds – improved fuel efficiency – legendary VariProp quality standards.

**VARIPROFILE — MORE FOR LESS!**

207-354-7064 | [info@variropusa.com](mailto:info@variropusa.com) | [www.variropusa.com](http://www.variropusa.com)



## CUSTOM HARD TOPS *Power or Sail*



Wavestopper hard tops  
Full service canvas & upholstery  
Dodgers, biminis  
Custom molded roof tops  
**(707) 812-8108**  
[baysidecanvas3@aol.com](mailto:baysidecanvas3@aol.com)



*serving the entire Bay Area*

## DURABLE GOODS

Better Materials  
Thoughtful, Innovative Designs  
Top Quality Workmanship



All sewing in Tenara thread

- Classic dodgers and biminis
- Drop-top folding dodgers
- Enclosures • Custom canvas

1230 Brickyard Cove Road, #106  
Pt. Richmond, CA 94801  
In Brickyard Cove Marina

**(510) 234-4400**

Quality  
Yacht  
Canvas



## MARINE INSURANCE SPECIALISTS

**Your best source for Yacht and Boat Insurance  
tailored to your needs and competitively priced**

**We Insure:**

Sail or Power ♦ Classic or Contemporary  
Fiberglass ♦ Aluminum ♦ Steel ♦ Wood

At Heritage Marine Insurance you will find knowledgeable insurance professionals who provide the best service and the finest coverage available today.

*Please contact us for a quote*

[www.heritagemarineinsurance.com](http://www.heritagemarineinsurance.com)

**800-959-3047**

Fax 860-572-5919

Email: [classics@heritagemarineinsurance.com](mailto:classics@heritagemarineinsurance.com)

## LETTERS

advised them that we were dropping out of the Ha-Ha to go to Punta Baja to check the keel and deal with rigging issues, and that we no longer needed them to stand by.

We made it to Punta Baja, where several other boats had taken shelter, and where we spent a restless, windy night with additional rigging problems. Until the wind quieted down, I was not able to repair a partially furled jib that had us swinging around on the anchor. The next day we were able to use the main halyard to make a sling to hold up the boom, repair the jib, and replace some badly frayed lines. We headed back to San Quintin that day, then did an overnight to Marina Coral in Ensenada, where we'd spent six months with *Passage II* some 10 years before. We then had the boat hauled to inspect the rudder, the prop shaft, the keel, the keel bolts and so forth. There was no lasting damage.

It was a close call, but an amazing experience that we'll never forget.

Jim Cassidy & Lucy Lowe  
*Passage II*, Hunter 410  
Channel Islands

*Readers — Jim and Lucy wrote the above as a general letter to friends a short time after the incident last November. They mentioned it to us when we saw them in Puerto Vallarta in March, and we asked them to let us share it with our readers so everyone will be aware of the danger of fishing lines off the coast of Baja. Such lines can be a real problem. Profligate snagged one of her lines on one in a previous Ha-Ha, and somebody had to go into the water to clear it. Fortunately, it was relatively calm, as it would have been difficult and dangerous in rough weather.*

*Fish and lobster traps are also major hazards on the way from San Diego to Cabo. The day after we stood by *Passage II*,*



LATITUDE / RICHARD

*After standing by 'Passage II', 'Profligate' came to the aid of 'Eagle' off Cedros Island.*

*we went to the rescue of another Ha-Ha boat that had gotten its rudder fouled in some kind of fish trap/net five miles south of Cedros. We launched our dinghy and sent three of our crew over to help. By this time the wind and seas had died down, but there was still a large swell running. Profligate crewman Don Hall spent about 20 minutes in the water cutting the boat free.*

*While the fish and lobster traps are in relatively shallow water, there are other big fishing lines far out to sea, and they are often very poorly marked. So keep your eyes open and be careful out there — particularly between Cedros Island and Turtle Bay, where there are lots of fishing lines and traps.*

⇕ **TO WHAT END DID I GO CRUISING?**

In my last correspondence, I was belly-aching about the difficulties of the 'Thorny Path', about the herding instinct of some cruisers, and about bashing 1,500 miles against the trades from the East Coast of the U.S. to the Eastern Caribbean. As some will remember, my original plan was to singlehand around the world starting from California. That plan was dashed when the Coast Guard transferred me to the East Coast for my last tour of duty. Fine, I thought, I'll just start my circumnavigation from Newport, Rhode Island — which is what I did in September of '07.



*A quiet, well-protected cove with ample parking and amenities*



# ❖ EAST BAY ❖ OPEN SPACE

Three great opportunities from the East Bay's finest marina:

- **60-ft Berth** – Hard to find large berth now available
- **Covered Berth** – Sun protection for brightwork
- **Office Space** – Ideal brokerage/sales office at the water's edge

Fortman Marina – an impressive history updated with contemporary amenities

*Considering a move?*  
Contact us for excellent rates:

**(510) 522-9080**

**[www.fortman.com](http://www.fortman.com)**



**shadetree**  
fabric shelters

- Sun/Rain awning, self supported, no halyard.
- Rigid, folding, flexible frame. "Stands on lifeline".
- Waterproof, marine grade construction throughout.
- Easy up & down. Stows complete in 10"x36" bag.
- Designed for use in true cruising conditions.
- Stock models for up to 50ft LOA \$300-\$800.
- Custom designs also available.

[www.shadetreefabricshelters.com](http://www.shadetreefabricshelters.com)

email: [info@shadetreefabricshelters.com](mailto:info@shadetreefabricshelters.com)

1-888-684-3743 1-251-987-1229

## **BETA MARINE WEST**

**Beta Marine Diesel Engines and Generators**

With Dealers in:

- Los Angeles
- San Pedro
- Wilmington
- Santa Barbara
- Newport Beach
- Morro Bay
- Ventura
- San Diego
- Hawaii

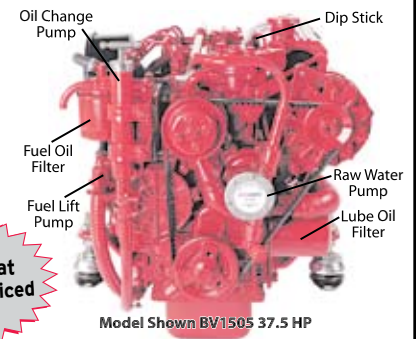

Model Shown BV1505 37.5 HP

**HIRSCHFELD YACHT LLC**  
Marine Repair and Installation Specialists  
Full Service Shop with Dockside Access

Electrical	Engines	Outdrives
Generators	Inboard/Outboards	Propellers
Controls	Installation	Transmissions

**[www.betamarinewest.com](http://www.betamarinewest.com)**

**415-332-3507**

**39 Liberty Ship Way, Sausalito 94965**

# Yacht Portraits

Watercolor

Oil Painting

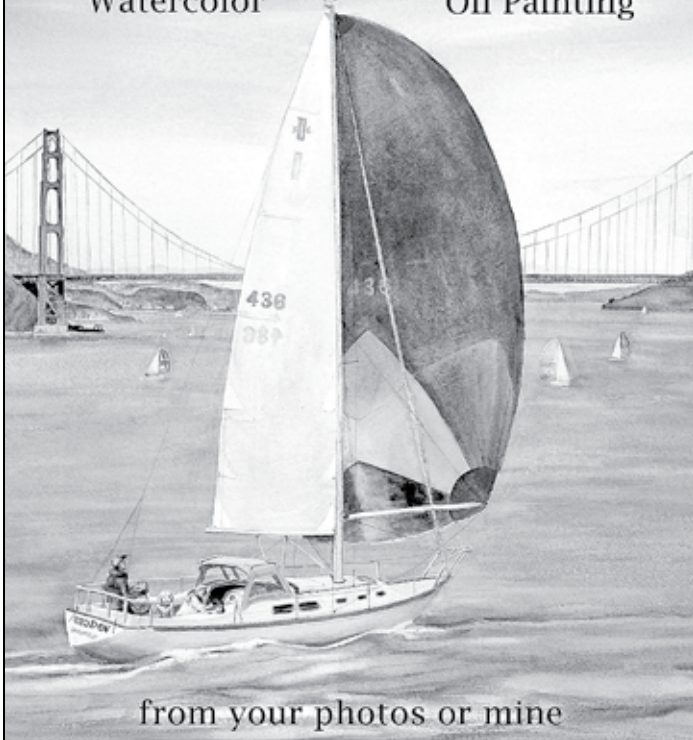

from your photos or mine

MargaretFago.com

510 522-1309

# LETTERS

Much has happened since then. The bottom line is that I spent the winter of '08-'09 sailing down-island through the Leewards and Windwards, during which time I realized that I wasn't getting the pleasure that I'd expected from the cruise. It's not that I didn't have magical moments or that every waking moment was misery, but rather I had a consistent low-grade anxiety about my slow progress. So after leaving my Westsail 32 *Christa* in Grenada for the '09 hurricane season, I sailed her to Naples, Florida, where I spent last winter. By the time this letter reaches print, I will probably have trucked *Christa* back to my beloved Sausalito.

The funny thing is that I truly enjoy sailing and the ocean. But the totality of the circumstances — my being alone the vast majority of the time, the letdown of not very many legs being beam or broad reaches, and my naïve pre-conceived expectations

COURTESY CHRISTA



'Christa' at anchor in one of the many beautiful places Christian visited.

compelled me to stop and reassess. I realized that there are many ways to experience the ocean, and that my intended trip doesn't have to be done in one shot, or finish in the same decade it was begun — or even with the

same boat it was begun on. I also realized that starting my journey against the tradewinds was an enormous mistake.

It took a taste of the cruising life for me to flesh out my personal cruising philosophy. I now think that few people are geared for solo sailing, let alone taking years to sail around the world singlehanded. I have a deep respect for those who have done it, but it's not for me. I always knew I didn't want to go around alone, but I figured that I would endure it to achieve my goal of a circumnavigation. It took me almost two years of singlehanded to figure out that doing it alone was going to be a deal-breaker.

While I never suffered from a debilitating loneliness, I nonetheless felt lonely sometimes. But things can be confusing, because while I saw couples who were cruising in marital bliss, I saw others who cruised in marital disharmony. Some married people even envied me because of the apparent freedom I enjoyed being single. I finally decided that the grass always seems greener on the other side of the fence.

I did learn that I had the boat, the skills, and the mental state to sail around the world alone. But I kept asking myself, "To what end?" For families traveling with children, the obvious answer is the experience and education children derive from such an experience, as well as the strengthening of family ties. Indeed, it seemed to me that it was the families, more than anyone, who thrived on cruising. But for me solo, I had doubts. I'd set the goal for myself many years before, and I simply continued with year after year of preparation, with no clue that the reality might be different from the dream. My first year of cruising was pretty exciting, but then the luster of the cruising life started to wear off.

Finding one's balance is as important in cruising as it is in life. Some cruisers are able to just plop the anchor down, head ashore for 48 hours of touring, then on day three weigh anchor and head to the next destination. I can't roll like that because, among other things, it takes me two days to recover from a passage. This is why some people I met while cruising have made it 75% of the way around the world while I was still in the Caribbean analyzing the weather for the trip to the

## McDERMOTT COSTA

insurance brokers - est. 1938

### Commercial Operations

- COMMERCIAL POLICIES  
Marinas, Yards,  
Yacht Clubs,  
Brokers,  
Shipwrights

### Pleasure Yachting

- YACHT & BOAT POLICIES  
Offshore, Coastal,  
Inland and  
Liveaboards



Lic. #OB21939

**Bill Fowler**  
MCDERMOTT COSTA INSURANCE  
(925) 606-6606 Fax (510) 357-3230





# VOLVO PENTA

**VOLVO  
PENTA**  
POWER CENTER



**PARTS • ENGINES • SERVICE • WARRANTY**

*Had a Fun Summer? Call Now for  
Service or Repower and Keep Your Boat Happy!*



**AUTHORIZED GAS/DIESEL POWER CENTER**

*Serving Northern California and Hawaii*

[www.helmutsmarine.com](http://www.helmutsmarine.com) • (800) 326-5135

**MARINE SERVICE INC.**

619 CANAL STREET, SAN RAFAEL, CA 94901  
415-453-1004 • FAX 415-453-8460

**UPGRADE • REPAIR • REPLACEMENT**



**Sausalito Marine**

**Electrical Shop** "The Project Place"

300 Harbor Dr., Sausalito, CA 94965

**(415) 332-9030**

**WINTER DISCOUNTS IN EFFECT!**

**October 15-January 15**

Mention this ad for a

**20% Discount on All Labor**

One-year warranty on all parts and labor

- Is your charging system leaving you feeling listless?
- Considering that major re-fit, re-wire, equipment upgrade or modification?
- Have gremlins invaded your electrical system?

**CONTACT US TODAY FOR AN  
ON BOARD CONSULTATION**

**(415) 332-9030**

[www.sausalitomarine.com](http://www.sausalitomarine.com) • [info@sausalitomarine.com](mailto:info@sausalitomarine.com)

**SAVE**  
on North Sails  
quality, durability  
& performance!

**NORTH SAILS  
direct**

It's easy to measure your own boat  
and SAVE on the world's best  
cruising and racing sails. Log on to  
[northsailsdirect.net](http://northsailsdirect.net)  
or call 888-424-7328.

Free tape  
measure  
with every  
order!

**CAPTAIN'S COURSES**  
Classroom classes in 15 cities and now Online!



**Captain's License**

U.S. Coast Guard approved courses and testing. Approved for Veterans.

**Now is the ideal time to get a Captain's License!**

Fall courses are scheduled in San Rafael, Newport Beach, Santa Barbara, Long Beach and San Diego, **or** enroll for the **ONLINE** course and take the test at any of our facilities on your way South.

Of Special Interest for **Baja Ha-Ha** cruisers:  
**Oct. 16-17 & 23-24** - Lee Chesneau's **BASIC WEATHER** (Levels I & II weekend courses) as well as the Meteorology course for professionals

Official Sponsor  
2010 BAJA HA-HA

To enroll or for more info: [www.MaritimeInstitute.com](http://www.MaritimeInstitute.com)  
or **CALL TOLL FREE 888-262-8020**

**MARITIME INSTITUTE**

**FULL SERVICE MOBILE RIGGING**

- *Competitive Rates*
- *Firm labor quotes on most projects*
- *17 years experience*



Call John Hansen



*Alameda*  
**(510)815-4420**  
*yachtcheck@yahoo.com*

## LETTERS

next island. Different strokes for different folks.

Maybe my sailing journey would have continued with the right helpful sailing partner. I marveled that couples and whole sailing families were able to get away so rapidly and easily. I guess it's common sense because they had anywhere from two to five times as many people to do the same amount of work. So the things I thought about while raising the anchor probably never occurred to those on boats with more crew. But



COURTESY CHRISTA

**Christian found that solo sailing wasn't as fulfilling as he'd hoped.**

solo was — and is — my current lot in life, and I wasn't about to let that stop me from cruising.

Over time, though, being single is one of the reasons why I metaphorically ran aground. But there were others. During my time in the Coast Guard, I spent nearly all my time at sea or engaged in nautical

endeavors. I'd also had been living aboard *Christa* for nine years before I took off from Newport. As a result, the ocean had become less of a novelty, and I think I got burned out.

It seems to me that being burned out manifested itself in a sense of intellectual stagnation. I was inbound to a dinghy dock with my friend Tom from *Sandpiper* when I experienced what I think was one of the critical moments in my life. We soon passed a guy in the cockpit of a weather-beaten boat. He was a wrinkled, old singlehander, with cancerous skin and unwashed hair, peering at us through beady eyes. He was sketchy. Although he was only kidding, Tom said, "Dude, that's gonna be you." Not me, brother. That will not be me.

It wasn't long after that incident that I decided to tack. Because of my good fortune and 20 years of service in the Coast Guard, I had many options. In fact, even if I'd become cloaked in sailing bliss, I likely would have stopped sailing anyway, or at the least been churned into turmoil, and it would have had nothing to do with my diminished enthusiasm for cruising. No, the real reason, and a major driver of what I'm viewing as my sailing sabbatical, was the passage of a post-9/11 Congressional bill that allows me to have my tuition paid by the Veterans Administration — with help from the Dominican University of San Rafael endowment. When the opportunity to further my education presented itself so clearly, I decided to pounce.

I initially had some feelings of embarrassment about my change in course, especially since I had sung from the treetops about my plan of sailing around the world. I wondered what the followers of my blog would say. A few people have criticized my decision, but none of them were cruising friends who are aware of the sub-surface rigors of the cruising life. It was the armchair sailors who questioned my sanity.

I regret nothing of the last three years — with the exception of my starting my cruising on the Thorny Path. Even though I was out for less than three years, it proved to be a positive experience. I enjoyed many of the things that other cruisers rave about, such as the people you meet along the way, the cultures, the awesome power of the sea, and palms swaying in the breeze. I experienced all of that. I just think my journey around the world will be a little lazier than I intended. I was nailed to the dock for three months in Florida before returning to San Rafael, a working stiff again, but I find myself viewing my sailing footage again and again. Must not have been that bad. Give up? Never!

# NEW VJ v-grip Jammer



**antal**

EURO MARINE TRADING, INC. / 62 HALSEY STREET UNIT M  
NEWPORT, RI 02840 / TEL: 401.849.0060 TOLL FREE: 800.222.7712  
[WWW.EUROMARINETRADING.COM](http://WWW.EUROMARINETRADING.COM)

## RICHARDSON BAY MARINA formerly Kappas Marina

MODERN FACILITIES IN A WELL-PROTECTED HARBOR

Concrete  
Dock System

Well Maintained  
Facilities

Beautiful  
Surroundings

- DEEP WATER BERTHS:  
BASIN AND CHANNEL  
DREDGED
- CARD KEY SECURITY SYSTEM
- DOCK CARTS
- PUMP OUT STATION
- AMPLE PARKING
- CLEAN SHOWER AND  
TOILET FACILITIES
- WITHIN WALKING  
DISTANCE: MARKET/DELI,  
LAUNDROMAT,  
RESTAURANT
- AT EACH BERTH:  
LARGE STORAGE BOX,  
METERED ELECTRICITY,  
PHONE HOOKUPS, WATER

**BERTH YOUR BOAT IN SAUSALITO**

415 332-5510 [www.richardsonbaymarina.com](http://www.richardsonbaymarina.com)  
100 Gate Six Road, Sausalito • Fax 415 332-5812



**CDI**  
Cruising Design, Inc.

The best value and reliability

- Mainsail and Jib reefing
- The only U.S. patented furling system for Cruising Spinnakers
- Manage all your sails safely from the cockpit!

**607.749.4599**

[www.sailcdi.com](http://www.sailcdi.com)

[sailcdi@verizon.net](mailto:sailcdi@verizon.net)

Salt Harbor Studio  
877.344.SALT (7258)  
www.SaltHarborStudio.com



## Nautical Holiday Cards

# SAL'S

INFLATABLE SERVICES, INC.



Achilles  
Hypalon  
Inflatable  
Tender



Four-Person  
VIKING RescYou

## No Matter How Far You Sail

- Baja Ha-Ha
- South Pacific
- TransPac

## SALES • SERVICE • RENTALS

- GPIRBs
- LIFERAFTS
- EPIRBs
- FLARES
- SURVIVAL SUITS



PHONE (510) 522-1824 FAX (510) 522-1064

1914 Stanford Street, Alameda, CA 94501  
salsinflatables@sbcglobal.net • www.salsinflatableservices.com

## LETTERS

P.S. Thank you *Latitude*, as you're probably one of the few sailing magazines that would publish a story about a cruise that didn't end in total bliss.

Christian Allaire, (USCG, Ret.)  
Christa, Westsail 32  
San Rafael  
www.christianallaire.com

Christian — Interesting letter. But why would you feel embarrassed or give a hoot what anybody else thought about your change in plans? It's your life, so live it whatever the hell way you want to. Besides, what cruiser doesn't change his/her plan with every change in the tide?

The thing we think throws a lot of first-time cruisers is that there is no right or proper way to do it. So much freedom can be disorienting. People wonder if they should be like Mike Harker and go around in 11 months, or like Paul and Susan Mitchell and take 25 years. The truth is that people cruise in different ways on different boats for different reasons — and with lots of different results. A few people hate it, most like it quite a bit — especially on a six-months-on, six-months-off basis — and some absolutely can't live any other way.

Breaks are good for cruisers. As we've noted before, after we had our Ocean 71 Big O in the Caribbean for about six years, we just got fed up with the whole program. So we sailed her down to Venezuela, threw off all the crew, and put her on the hard. We didn't know when we'd come back, and simply stopped thinking about her. It was a big load off our mind at the time. Nine months later, we couldn't wait for Hugo Chavez to resign from power — this was after his coup. When he did resign, we caught the first plane from the U.S. allowed back in Venezuela. That started another six years of perhaps the most fun we ever had with Big O. The moral is that 'vacations' from cruising can be very beneficial to your cruising pleasure. Indeed, it's one of the reasons why six months of cruising, followed by six months of doing something else, is so popular.

For some cruisers, keeping the boat up, making new friends, exploring ashore, diving, surfing and combinations of other activities provide all the stimulation they want. Others need more. In places like the Caribbean and the South Pacific, mental stimulation can be a little hard to come by. Fortunately, the internet is becoming more easily and economically available and, if used intelligently, can be the gateway to all the mental stimulation one might need.

We also agree with you that starting out on the Thorny Path might have been a mistake. That's a lot of nasty upwind, upcurrent work for any boat, let alone a Westsail 32, a design that doesn't excel on that point of sail. In some ways it probably would have been easier for you to sail from Newport to Thailand than from Newport to and around the Caribbean.

So enjoy school and life in Sausalito. And no worries — if by late October you find the weather has gotten too cold and the classes too boring, we'll have saved a slot for you and Christa in the Ha-Ha. Lord knows you wouldn't be lonely in a fleet of 600 other cruisers.

In a typical month, we receive a tremendous volume of letters. So if yours hasn't appeared, don't give up hope.

We welcome all letters that are of interest to sailors. Please include your name, your boat's name, hailing port and, if possible, a way to contact you for clarifications.

By far the best way to send letters is to email them to richard@latitude38.com. You can also mail them to 15 Locust, Mill Valley, CA, 94941, or fax them to (415) 383-5816.

# SAILBOATS ONLY

[www.hiddenharbormarina.com](http://www.hiddenharbormarina.com)



**Peace and tranquility  
in the middle of it all.®**

**HONDA  
MARINE**  
IT'S ALL ABOUT POWER.

**caribe**  
INFLATABLES

**Aquapro**  
INFLATABLES



**HONDA  
MARINE**  
IT'S ALL ABOUT POWER.

**TOHATSU**  
outboards

**Achilles**

We've been *THE* Bay Area authority for  
inflatables and outboards for more than 35 years.

Call us today for quotes.

**Voyager Marine**

1296 State St.

P.O. Box 246, Alviso, CA 95002-0246

**(408) 263-7633 • (800) 700-7633**

Open Tuesday thru Saturday



**REPAIR  
REPAIR  
REPAIR**

**NOW AT  
GRAND  
MARINA**

**ROOSTER SAILS  
A REPAIR  
LOFT**

**YOUR ROLLER  
FURLER UV COVER  
SPECIALIST**

**ROOSTER SAILS**

2021 Alaska Packer Place, Box 18, Alameda  
**(510) 523-1977**

[www.roostersails.com](http://www.roostersails.com) • [rui@roostersails.com](mailto:rui@roostersails.com)

Open M-Th 9-6 • Fri 9-5 • Sat by appt.

Owned and Operated by Rui Luis • Experienced Sail Repair and Fabrication

**NOW OFFERING NEW CRUISING SAILS!**

**SAIL REPAIR SPECIALISTS • COMPETITIVE RATES • RECUTS • CONVERSIONS**

## THE RELIABILITY'S BUILT IN!



All boats powered by Honda Marine engines.

**HONDA**  
**MARINE**  
PROVEN



We offer complete service on all Honda outboards and inflatable boats and take pride in providing the kind of customer satisfaction that you expect from Honda.



**The Dinghy Doctor**  
1271 Scott Street  
San Diego, CA 92106  
Tues-Sat, 9am-5pm  
**(619) 804-6921**  
www.thedinghydoctor.com

2 blocks off Shelter Island

### BF20

- Unsurpassed fuel economy
- Shallow water drive
- Largest displacement in its class (21.4 CI)
- Hi Output alternator (12 amps)

AB, Achilles, Zodiac, Walker Bay, repair kits, engine parts, and everything you will need in Mexico.

Always wear a personal flotation device while boating and read your owner's manual.

## LOOSE LIPS

The Hottest Spot on Earth.

Santa Barbara no longer holds the record, and judging from this photo taken when *Profligate* was anchored off Stearns Wharf, it seems an unlikely candidate to have ever been. But Santa



LATITUDE / NICK

With typical summer days looking like this, Santa Barbara hasn't set any record highs this year.

Barbara did indeed once hold the record for the hottest place on the planet. It was so hot that flying birds dropped dead out of the sky. And it's not as if it happened that long ago either.

Back when we started *Latitude* aboard our Bounty II *Flying Scud* at Sausalito's Clipper Yacht Harbor in '77, Bob and Gail Jensen berthed *Simoon*, the Columbia 50 they would take to the South Pacific a number of times in those pre-GPS days, a few slips away. *Simoon* is the English spelling of the Arabic word 'simoom', which means 'to poison', and refers to a particularly hot and dust-laden local wind that primarily blows in the Sahara, Palestine, Israel, Jordan, Syria, and the deserts of the Arabian Peninsula.

We say 'primarily' because, according to Wikipedia, there has been one case of a simoom in North America. That happened on the afternoon of June 17, 1859, at — you guessed it — Santa Barbara. The temperature that morning was a typical 75°, and it would return to that in the early evening. But at about 1 p.m., super hot winds filled with dust began to blow down toward the sea from the Santa Ynez mountains directly in back of the city. By 2 p.m., the air temperature had reached an astonishing 133°! By the way, this temperature wasn't recorded by some drunken gaucho with a drug store thermometer, but rather by scientists on a U.S. Coastal Survey Vessel that just happened to be right offshore.

According to the official government report, "Calves, rabbits and cattle died on their feet. Fruit fell from trees to the ground scorched on the windward side; all vegetable gardens were ruined. A fisherman in a rowboat made it to shore at the Goleta sandspit with his face and arms blistered as if he'd been exposed to a blast furnace."

Years later a temperature of 136° was recorded somewhere in the Middle East to take the 'world's hottest' record, while 75 years later, a temp of 134° was recorded in Death Valley, setting a new U.S. record.

The only weather records set this year at Santa Barbara have been for the most fog and probably the coldest water. The water was so cold that we maintained an iceberg watch when we sailed across the channel to Santa Cruz Island in September.

For the nearly 200 boatowners who signed up for the Ha-Ha that starts at the end of this month, the Pacific Coast of Baja is cooler than most years, but it's still 82° at Cabo San Lucas and up to 85° just inside the Sea of Cortez. We don't know about you, but we can't wait to take the heat.

— richard

## COAST MARINE

& INDUSTRIAL SUPPLY INC.

398 Jefferson St. San Francisco - On the Wharf.

Call **Bruce Becker: (415) 673-1923**  
**800-433-8050**

Fax (415) 673-1927

**LIFE RAFT**  
Sales & Service



U.S.C.G. Approved Testing Facility

- ★ U.S.C.G. life raft facility for Solas commercial yacht and fisherman rafts
- ★ COMAR DEBARKATION LADDERS
- ★ COMAR PILOT LADDERS
- ★ COMAR WORK LADDERS
- ★ All U.S.C.G. approved

**GUINNESS** WORLD RECORD "World's longest tested ladder 320ft."

Major Distributor for:



**Pains Wessex**  
Safety Systems

**STEARNS**



IN SAN DIEGO CALL OCEANS WEST 619 544-1900

# Sailing faster has never been this easy

North's patented **NorDac Radian™** warp-oriented polyester sailcloth is the world's first to combine superior low-stretch radial performance with the durability, easy handling and mildew resistance of non-laminated woven polyester. If you're looking for more performance from a woven sail, *this is BIG!*

To learn more about Radian, visit [www.northsails.com/Radian.aspx](http://www.northsails.com/Radian.aspx) or call your North Sails representative today.

**FREE!**  
**ONE YEAR**  
**SAIL CARE**  
**& REPAIR**  
with purchase of a new North sail\*



\*Restrictions may apply. Contact your North Sails representative for details.

*Better by Design*

**Sausalito** 415-339-3000

**San Rafael - Sail Care** 415-453-2142

**Channel Islands** 805-984-8100

**Marina Del Rey** 310-827-8888

**Long Beach** 562-795-5488

**Costa Mesa - Sail Care** 949-645-4660

**San Diego** 619-224-2424

[www.northsails.com](http://www.northsails.com)



# Radian



## OYSTER POINT Marina/Park



*A full service marina located in South San Francisco with berthing and guest dockage available*

For information and pricing call

**(650) 952-0808**

[www.smharbor.com/oysterpoint](http://www.smharbor.com/oysterpoint)

## 2010 MODEL CLEARANCE

**Reliable in Mexico... And Everywhere!**

*Our 2010 Model Clearance is your best chance to get a great price on a reliable outboard for Mexico.*

Tune-ups and spares too...



**Engine Service Center**

Auxiliary and outboard repair, upgrade & service. Be ready for the season!

POWERED BY

**HONDA  
MARINE**



© 2010 American Honda Motor Co., Inc.

Always wear a personal flotation device while boating and read your owner's manual.

5-year warranty standard on all new Honda outboard engines purchased.

Check with participating dealers for complete details.

Limited Repos  
Remain!

**Outboard Motor Shop**  
Where the professionals shop!

**(510) 533-9290**

[www.outboardmotorshop.com](http://www.outboardmotorshop.com)

333 Kennedy St., Oakland, CA 94606 • Fax 510-533-3374

# SIGHTINGS

## the (good) fortune 400

If you look on the spine of this issue, you'll see that it's the 400th issue of *Latitude 38*. When I took the Crazy Horse Canyon Road turn-off on Highway 101 on my way back from the printer in Santa Barbara in March of '77 to drop off the first copies of the first issue in Santa Cruz — something I vividly remember — I never dreamed that the 40-page issue created with \$2,000 savings would become what it has in the ensuing 33+ years. And that it would lead to things like the

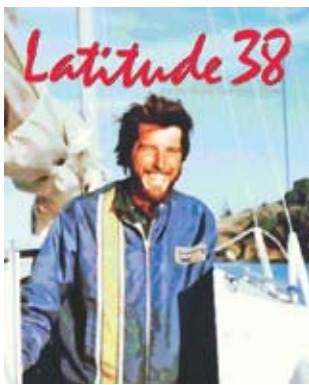

**Richard Spindler, aboard his Bounty II 'Flying Scud' at anchor at Paradise Park, Tiburon, 1976, thinking to himself, "I think I'll start a sailing magazine."**

Baja Ha-Ha and a host of other sailing events in Mexico, as well as *Lectronic Latitude*. Even more shocking is that I, who had been an ultra casual, semi-irresponsible semi-hippie, would abruptly be transformed into the workaholic that I remain, unfortunately, to this day. (I know my life sounds as if it's one of endless leisure and sailing pleasure, but the reality is actually just a tad different.)

On the occasion of this milestone, I'd like to again sincerely thank the three groups who have made it all possible. First, you the readers, without whom the magazine would have no reason to exist. Second, all of the great advertisers — and please take a bow, Kame and Sally of Pineapple Sails for having supported us with a full-page in the same spot for all 400 issues. And certainly not the least, the group of incredibly hard-working people who have labored at *Latitude* over the years,

employees who have always gone the extra mile to produce the best possible issues they could. Thank you, thank you, and thank you.

But on this particular milestone, I'd especially like to thank a subgroup — those of you who have taken the time to send letters to the editor. These letters have inspired me to think, laugh, scream, and produce just about every other reaction known to man, though usually not all from just one letter. The letters have provided me with a unique place and opportunity to dispense factual information that I've gathered over the decades, as well as opinions, musings — and even the occasional uncontrolled, written-in-the-middle-of-the-night rant. What fun!

Having written and/or edited, taken photos for, and laid out something in the realm of 14,000 editorial pages over the years, I'm happy to say I still get a kick out of it.

Once again a sincere and heartfelt thanks to every one of you who has been a part of *Latitude 38*.

— richard spindler, publisher

## a rompin', stompin' schooner race

When "nothing breaks and nobody gets hurt" during a race on the Bay, most local sailors figure they've had a pretty successful day of competition. But the third annual Great San Francisco Schooner Race, August 28, had to be measured by a completely different yardstick. With sustained winds in the low-to-mid 30s, gusting to 40, there were plenty of torn sails, all sorts of vintage gear failures, and probably more bruises than anyone could count. But as one excited finisher put it, "Hey, at least no one had to be hospitalized." By all accounts, it was one heck of a wild ride that won't soon be forgotten — and more fun than a dozen light-air daysails put together.

During the post-race party at the San Francisco YC, the adrenaline was still pumping within many crew members as they swapped tales about near broaches, mid-race heroics, and sheets of white water that washed down the leeward gunwales, soaking jib trimmers to the skin. Great stuff!

continued on outside column of next sightings page

## west harbor is

Just in time for the Rolex Big Boat Series last month, the City finished the dredging of San Francisco's West Harbor, home to San Francisco Marina, Golden Gate YC, and St. Francis YC. It took about two months, but the dredging not only deepened the channel from 12 to 18 feet, but also widened it.

Bright Winn, port captain at GGYC, also reports that a 100-ft temporary dock will soon be installed on the south face

**Screamin' schooners — spread, 'Regulus' made a splash in the third annual Great San Francisco Schooner Race; inset right, 'Californian' skipper George Sutherland has his hands full as the guest helmsman aboard 'Eros'; inset below, Billy Martinelli's 'Gas Light' and Jeff Hawkins' race-winning 'Jakatan' grind through a breeze-on Saturday on the Cityfront.**



JOHN SKORIAK



## freshly dredged

of the club. "When the entire harbor is rebuilt next year," says Winn, "we'll have four 50-ft berths, plus a 50-ft end tie." Winn notes that "in his day" the club was busy with cruise-ins, but the silting of the harbor coupled with the deterioration of their City-owned docks meant a decline in visitors. "We're looking forward to the day when we can again be the great hosts we once were," Winn says.

— *ladonna*

## schooner race — cont'd

As in previous years, the contest was set up as a pursuit race, where starts were substantially staggered based on handicaps so that — in theory — all boats would finish at close to the same time. This year, the entire course was laid out in the unbridled air of the Central Bay, which meant every boat — whether gaff-rigged or marconi — was able to run the entire zig-zagging course at her full potential.

Sadly, though, the rowdy conditions took such a toll on the fleet that only 10 out of 17 starters finished. The most serious mishap occurred aboard Ed Witt's 50-ft gaffer *Regulus*, which lost her steering so close to Alcatraz that she was in danger of washing up on the rocks

continued on outside column of next sightings page



# SIGHTINGS

## schooner race — cont'd

before crewmen had a chance to rig her emergency steering gear. Alan Olson's 85-ft steel schooner *Seaward* was forced to retire after both her headsails shredded, and the modern 86-ft gaffer *Kaiulani* nearly had to quit also when her mains'l split. But skipper Chris Johnson and his crew somehow managed to tuck in a reef above the tear and finish the course. Meanwhile, aboard the exquisite 115-ft *Eros*, two 3/8-inch stainless steel bolts holding a jib fairlead sheared off under the load as if they were matchsticks. The splendid 65-ft Herreshoff *Brigadoon* didn't suffer any major breakage, but diehard racer Terry Klaus was forced to kick on his engine and retire in order to avoid a downed windsurfer and the windsurfer's rescue boat.

Despite all the carnage and calamity, though, we'd bet all who competed would agree it was a glorious day on the water; the sort of rompin' stompin' joy ride that makes Bay sailing world-famous. And just having the rare opportunity to watch so many meticulously cared-for traditional yachts racing hell-for-leather was certainly worth

continued on outside column of next sightings page

## update from the

Sam Keston, mate aboard the *Derek M. Baylis* — a research vessel for Sea Life Conservation — reported last month that the boat was off the coast of Fort Bragg, mapping the sea floor.

"We've teamed up with Chris Goldfinger and his students from Oregon State University to map part of the San Andreas Fault that has never been observed up to this point, says Keston. "To do this, we've rigged something called a 'multi-beam sonar' — think depth sounder on steroids — to the side of the boat and are making passes in a grid-like formation. What's so exciting about this is that it's the first time a sonar such as this has been hung from the side of a sailboat (their typical



**Gettin' groovy on the Med** — Find Andrew Vik's report on his third summer cruise in the Med aboard 'Geja' in 'Changes'. From anchoring in idyllic Greek lagoons (above) to diving into the Adriatic (spread) to swimming with Italian locals (right), it sounds like a good trip.



## derek m. baylis

research vessel is a converted trawler). While some might think that downsizing from a 300,000-lb research vessel to a svelte 35,000-lb 65-ft WylieCat would mean sacrificing data collecting performance, so far the opposite has been true.

"The *Derek M. Baylis* is turning out to be the ideal vessel for this type of research. Our underside is very smooth and similar to a modern racing sailboat, so water flows over it very easily with no disruptive bubbles, unlike larger power research vessels. Sails stabilize the boat and make it more comfortable than a powerboat when we are beam to the sea. When it's windy we can turn the motor

continued in middle column of next sightings page

## schooner race — cont'd

a few bruises, sore muscles and soggy shoes. (For complete results, see [www.sfyf.org](http://www.sfyf.org).)

San Francisco YC organizers are already jotting down ideas to make next August's event bigger and better. And with any luck they'll attract even more splendid schooners to the party. The one suggestion we'd offer is, perhaps they needn't pray quite so hard for wind.

— andy

## how to shower aboard *profligate*

Don't know how to take a shower when cruising? We're not surprised. Based on the September-issue inquiry by Mr. Anonymous on the subject, and some of the responses published in this month's *Letters*, a lot of people don't know how to do it. We hope the accompanying photos and text answer all your questions.

Showering when cruising is actually very simple. 1) Go on deck, or to the back steps or the sugar scoop. 2) Arrange your water source, be it the outdoor shower or SunShower. 3) Get naked — unless you're in a place where it will get you arrested. 4) Let the soap and water fly. 5) If possible, shower with friends — it saves water and helps reach those hard-to-get places on your back. Besides, there will be more giggles. 6) Sun dry. What could be easier or more natural? Plus you'll save money on laundry by not using towels.

We know some cynics out there might suspect that we set up the accompanying shower photos. Not true. The photos were taken at the King Harbor YC the day after the Santa Barbara to Redondo Beach Race in '08. And as all the witnesses can attest — and there were plenty of them — the showering broke out spontaneously.

And lest anyone think the women in the photos are ringers, nothing could be farther from the truth. Not only had each one been instrumental in rescuing the three-person crew of the flipped trimaran *Existential Blowout* the day before, all of them have extensive sailing experience. In fact, we'd like to introduce them (see the spread on the next page).

The young lady aiming the nozzle from above is 21-year-old Rachel E. She spent five years cruising Mexico and the South Pacific to Australia aboard her family's Marquesas 53 *Rhapsody*. "We always showered on the transom because it was much more fun," she said. Upon the family's return home, she finished high school, then did a short stint at UC before enrolling at a university in China for 18 months of intensive study of Mandarin and Chinese culture. After doing this year's King Harbor Race on *Profligate*, she took off to a prestigious school in the Northeast where she'll continue her major in Chinese. For those curious about the effects on educational development of cruising during one's youth, Dana, Rachel's younger brother, who also did the family cruise, just started classes at Stanford after taking a gap year to work and travel in China.

The one getting showered in the photo is Mary F. During a long backpacking trip, she found herself working at Rick's Bar, the former cruising center in Zihua, where she crossed paths with Andy 'Mr. Puddle Jump' Turpin of *Latitude* in the spring of '07. As Mary was adventurous and came from a family of watersports enthusiasts, Turpin suggested she do a Ha-Ha. Six months later, she showed up at the Crew List Party and signed on with Wayne Hendryx and Carol

continued on outside column of next sightings page



LATTITUDE / RICHARD

**Mary helps Rachel get all the suds out of her hair.**

# SIGHTINGS

## showers — cont'd

Baggerly's Hughes 45 *Capricorn Cat*. Over the next 18 months, Mary sailed on a number of boats in Mexico. "For some reason, owners always encouraged me to shower on deck." She subsequently fell in love, and she and her guy ran a 100-ft yacht together for a season. The duo are now running another large yacht, having spent last winter in the Bahamas, and are currently aboard the yacht in Knoxville, Tennessee, of all places. An enthusiastic outdoor shower person during her sailing years, Mary, we suspect, mostly showers inside now.

The starboard scrubber is Heather C. who, while walking through the Monterey Peninsula YC in '06, spotted David Addleman, owner of the Cal 36 *Eupsychia*, sitting alone at the end of the bar. She liked what she saw and, Heather being Heather, walked up to him and said, "We should have sex!" The two spent the winter cruising Mexico on the Cal, came back to Monterey for the summer, then did the Ha-Ha

continued on outside column of next sightings page

## baylis

off or slow it down, reducing vibration and further increasing the accuracy of the instrumentation. And our fuel consumption has been almost too small to measure. As I write this, we've been out for over a week, running a generator 24/7, and still have managed an average of less than two gallons per hour. That's more than a tenfold fuel saving over their conventional boat. This isn't just good for our carbon footprint, but it allows us to stay out at sea longer and not waste time returning to the dock to refuel.

"Life aboard the boat has been great.



*A little help from your friends — Cherie and Heather lend Mary a helping hand while Rachel provides the wet stuff. Showering on a boat can be whatever you make it.*

## — cont'd

We haven't yet finished off the fresh veggies, but we are limiting our hot water showers. The only issue we've had is that the autopilot has been a bit finicky and will need some new parts when we come in to refuel. If the weather stays as nice as it's been we will continue doing this through early October, at which point we'll shift gears and resume our work tagging and identifying great white sharks near the Farallon Islands."

Go to [www.sealifeconservation.org](http://www.sealifeconservation.org) for more on their mission.

— ladonna

## showers — cont'd

and another winter season in Mexico. "Hell no, we never showered inside," laughs Heather. "In Mexico where it was warm, we'd use the SunShower. Up north, where it was cold, we'd heat some water in a kettle, put it in the SunShower, then shower outside. One advantage of showering naked, at least in the U.S. and Mexico — as opposed to the French Islands of the Caribbean — is that not too many people want to anchor near you."

Although David and Heather have gone their separate ways, they now both sail on Santa Cruz 50s. David bought his *X* in Malaysia, while Heather, when not tied up in film projects, crews on *Bay Wolf*, the Santa Cruz 50 that does corporate events, charters and sunset cruises out of Sausalito.

The port scrubber is Cherie S. Back in '91, Cherie and Jean Leiting, her Southern California partner in international mischief and

continued on outside column of next sightings page



LATITUDE / RICHARD

# SIGHTINGS

## showers — cont'd

adventures, decided they wanted to the Ha-Ha, so they flew up to the Ha-Ha party in Alameda. Cherie found the guy she wanted to crew with — Greg Retkowski, owner of the Morgan Out Island 41 *Sirocco*. "He wouldn't take me because his boat was already full of girls," says Cherie. "But I told him I would eventually get on his boat, he just didn't know it yet." Cherie and Jean ended up doing the Ha-Ha on Tom LaFleur's San Diego-based Swan 53 *Mistress*. But Cherie was right, a month later she was on *Sirocco* with Greg at the beginning of what became a two-year cruise to Florida via the Canal, the Cayman Islands, Puerto Rico and Cuba.

"Taking a shower inside a cruising boat is like wearing a bathing suit in a swimming pool," she says, although we don't think it's quite the metaphor she was looking for. "You don't go on a boat to be comfortable and have luxuries, you go to be out in nature." Cherie has subsequently done two more Ha-Ha's and all kinds of other sailing. She and Greg, who crewed aboard *Raven* this summer, are to

continued on outside column of next sightings page

## the resurrection

They say cats have nine lives. But until we heard about the rebirth of the PDQ 32 cat *Catalyst* — which capsized and was subsequently abandoned off the North Coast on July 7 — we thought that old adage applied only to felines, not to two-hulled sailboats.

After surviving her traumatic ordeal in the frigid waters off Fort Bragg, owner Kristy Lugert assumed that her newly-purchased dream boat was a total loss, and that she'd never see it again. But by sheer luck, the overturned hull showed up in a North Coast 'doghole' a few days later near the Mendocino County town of Albion.

Unbeknownst to Kristy and her crew



'Arabella' takes a ferry wake in style.



**Lookin' goooooood! Summer weather finally hit the Bay full force in September. There wasn't a weekend in the entire month that didn't see the Bay abuzz with boats. Besides local boats, dozens of southbound cruisers stopped in for a visit (read about seven of them starting on page 104). Here, 'Wanderbird' flies toward the Gate.**

## of catalyst

mates, Steve McCarthy and Greg McCuen — who were recuperating from their near-death rescue during the days following the incident — Kristy's brother, Jerry, took it upon himself to salvage the battered hull. With the help of his friend Les Waterman and others, they successfully towed the hull out of the rocky doghole to the safety of Albion Bay. After pumping her out and making a variety of repairs, including replacing the starboard rudder with a new one fabricated by a local fisherman, they towed *Catalyst* to the Bay behind Waterman's vintage 54-ft Chris-Craft, with Kristy at the helm. Friends Matt Bisset and Daniel Gray also came

continued in middle column of next sightings page



The folks on 'Peg' were all smiles.

## showers — cont'd

be married on October 10, the ninth anniversary of their meeting at Ha-Ha Crew List Party. "And yes," she says as if it were obvious, "we plan to sail in Mexico with somebody this winter, because winter isn't winter unless you sail in Mexico." As for Leightner, Cherie's original partner in mischief, as of late September she was doing a sea trial of a Gulfstar 47 in anticipation of buying it. A real nature-loving gal, Jean took her showers outdoors, too. "Jean doesn't know it yet," laughs Cherie, "but we're going to do the '11 Ha-Ha on her new boat. And we're going to take our showers outdoors, too!"

That's our shower story. If you do it differently, particularly if you have documenting photos, we'd love to hear from you.

— richard

## the sense of sailing

Having grown up sailing on the Hudson River and Long Island Sound, I've always loved being on the water. As an adult, I developed moderate hearing loss, and later, from undetected Lyme disease, I quite unexpectedly went deaf.

Before I became profoundly deaf, a sailing friend got me on crew in races, but I soon gave up because I couldn't understand the skipper's commands. I recently moved to the East Bay, still loving to be on the water and dreaming of sailing on the Bay, but hearing loss can cripple your self-confidence. I retired and figured that was that. Then I heard about BAADS.

The Bay Area Association of Disabled Sailors ([www.baads.org](http://www.baads.org)) is a sailing club run by disabled and able-bodied volunteers. The current commodore is Ed Gallagher, who is blind. BAADS is a mix of 100-200 sailors and volunteers, some able-bodied, some blind, some deaf, and some with significant physical disabilities. With six 303s and 11 Liberties, BAADS has the world's largest Access dinghy fleet in one place. The boats are rigged so people with mobility limitations or limited core strength can sail.

I started lessons in one such dinghy with an experienced BAADS sailor whose face I had to see to understand instructions. I knew the basic terminology from the sailing I'd done in the past so those words posed no difficulty. But more complex explanations about wind power, tacking, and currents took me a while to understand. Not that the understanding was hard; the hearing was.

After half a dozen nerve-racking days in strong winter winds in McCovey Cove, always with an instructor, I decided I would feel more comfortable in a bigger boat, so I switched to keelboat sailing. I spent most of the next two months of Sundays on *Orion*, an Islander 36, learning to drive the boat. Ed knew the boat like the back of his hand. When he took the helm, I saw how he sensed the boat's motion with his body, and how he felt the wind on his face and the sea's pressure on the wheel. During my turn at the helm, I practiced feeling the boat's progress. I learned to pay attention to the boat, not to the water rushing by. In short, I learned to trust the boat.

I decided that it was time to transfer what I had learned to dinghies. My first time out, I found that I was no longer scared when the dinghy sped upwind, heeling dramatically. I soon soloed with confidence. Now most Saturdays find me in McCovey Cove, practicing with whatever the winds give me. On Sundays, I go out in one of the group's four keelboats: *Orion*; *Raven*, a Freedom 20; *Heidi*, a Ranger 23; and *Tashi*, a Catalina 30.

So far I've sailed The Slot and tacked across Raccoon Strait. I have

continued on outside column of next sightings page



Margreta at the helm.

COURTESY BAADS



The helmsman of 'Island Girl' watches for traffic, and there was a lot of it!

## baads — cont'd

a lot more to learn — and I have to get stronger to crank that jib tight — but being out there with the wind and the water gives this deaf old girl new confidence.

My current project is to find nautical terminology in American Sign Language. When both the skipper and hard of hearing or deaf crew understand each other, we can move on to more advanced sailing, sooner and more safely. Thank goodness the boats always understand.

— margreta von pein

## the revenge of the evil mahi

"Honey, I'm really sick." These are not the words you want to hear from your husband when he's three days out of Honolulu on a singlehanded delivery to the Bay.

"It was the fish, wasn't it?" I asked as my fingers tapped 'ciguatera' into the Google search box. The day before, when he was 200 miles offshore, Rob had caught the biggest mahi mahi (dorado) of his life, and now he was as sick as he'd ever been. No way it could have been a coincidence.

I asked him to describe his symptoms and, as *Wikipedia's* page detailing the symptoms of ciguatera loaded on my screen, Rob rattled off all but the last two on the list: Nausea, vomiting, diarrhea, intestinal cramps, extreme weakness and fatigue, muscle and joint pain, severe headache, dizziness, tingling and/or numbness in the lips, mouth, and limbs, and hot/cold temperature reversal (cold things feel hot, hot things feel cold).

Without the presence of those last two, his symptoms could have been attributable to just about any foodborne illness. Besides, everyone knows that pelagic fish — those that spend their lives in the open ocean, such as mahi and tuna — don't carry ciguatera.

Ciguatera poisoning is an incurable disease caused by a naturally occurring neurotoxin produced by algae that live near tropical and sub-tropical reefs. Little fish eat the algae, then bigger reef-dwellers, such as barracuda and grouper, eat the little guys. The more little fish they consume, the more ciguatoxin — which is not harmful to fish — accumulates in their flesh. The toxin is extremely temperature-resistant, so no amount of cooking or freezing will make tainted fish safe for humans to eat. And since there is no cure for ciguatera — the toxin has to pass through your body the old-fashioned way — the only treatment is supportive care, i.e. fluid replacement and Depends.

While this may sound horrific — and if you're currently curled in the fetal position spouting from both ends, it most certainly is horrific — the reality is that ciguatera is one of the most common fishborne illnesses in the tropics. In some parts of the Caribbean, you'd be hard pressed to find someone who *hasn't* had it. In fact, *Latitude 38* Managing Editor Andy Turpin, who lived in the Caribbean for a number of years, suffered a bad case of it after unwittingly eating barracuda (he'd been told it was a different type of fish). "I really thought I was going to die," he recalled when I told him about Rob's plight. His words were not terribly comforting.

Two hours after Rob's initial sat phone call, during which I "encouraged" him to turn around, he called back to report that he was on course for Nawiliwili on Kauai. Oh yeah, and his lips, tongue, hands, and feet were tingling and going numb.

Having scoured the web in the preceding hours, I learned that ciguatera has, in fact, been linked to the occasional mahi, but is rarely fatal. I instructed Rob to take frequent small sips of water dosed with the electrolyte supplement Emergen-C and do what he could to rest, warning him that if he had any trouble breathing, he was to set off the EPIRB immediately, as that could be a precursor to lung paralysis.

Over the next two days, as Rob retched his way toward Kauai and

continued on outside column of next sightings page

## catalyst

along on the adventure.

The trip south wasn't easy, but it was a piece of cake compared to the ill-fated delivery attempt in early July. What will become of the mastless cat is now up to Jerry, who bought her for a dollar. An



COURTESY CATALYST

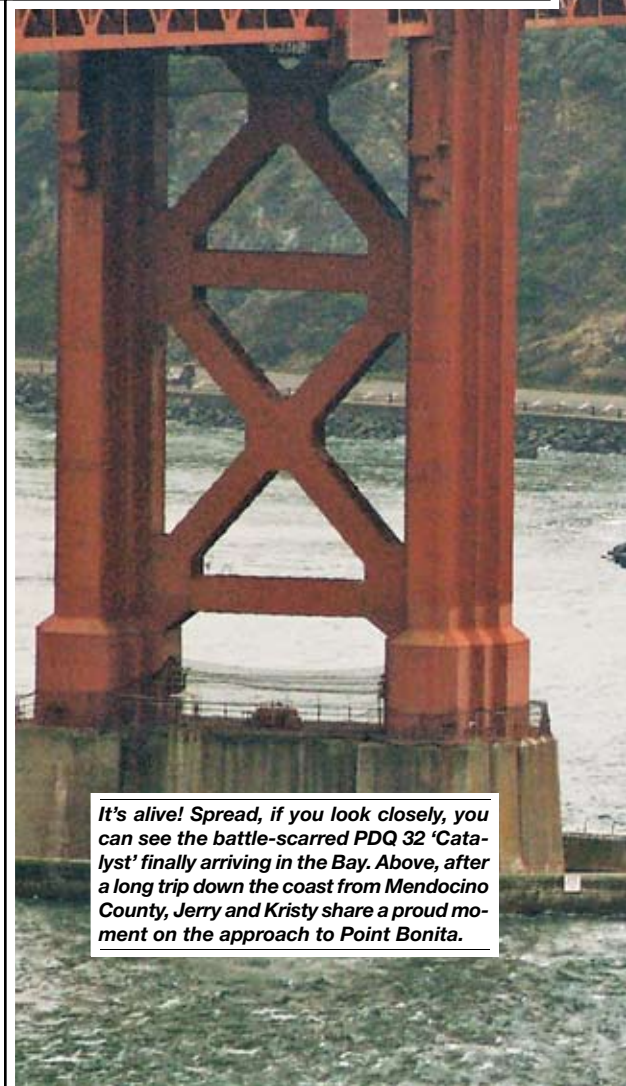

*It's alive! Spread, if you look closely, you can see the battle-scarred PDQ 32 'Catalyst' finally arriving in the Bay. Above, after a long trip down the coast from Mendocino County, Jerry and Kristy share a proud moment on the approach to Point Bonita.*



## — cont'd

engineer by profession, he just couldn't resist the challenge to refloat her and bring her back to life.

Kristy, by the way, has received an insurance settlement and may soon be shopping for a new boat. And she has undoubtedly thanked her father profusely for having the foresight to rent an EPIRB from Boat U.S. for the delivery, which was instrumental in saving the three crew members' lives.

If you're heading offshore this fall, be aware that not only are EPIRBs available for rent from a variety of sources, but so are liferafts of all sizes, various types of transponders, and satellite phones.

— andy

## mahi — cont'd

I booked a flight to Lihue, Nawiliwili YC members Maryann Holden and Rich Jensen coordinated a 'welcoming committee' to help an exhausted Rob land. As the boat cleared the breakwater, Rich jumped aboard from the club's Whaler. "I stuck out my hand and said, 'Hi, I'm Rich,'" he recalled later. "He said, 'I'm Rob, and I have to sit down *right now*.' Then he just sort of slumped onto the seat."

A very experienced solo sailor himself — he's sailed his Beneteau First 38s5 *Jazz* all over the North and South Pacific — Rich had no trouble dropping the sails, rigging some docklines, and pulling the boat into a slip at the yacht harbor. After securing the boat, I took one look at Rob and knew the worst was over. Clearly exhausted and very weak, he was more lucid than he'd been in three days, and was finally able to hold down food and water. He decided to hold off on going to a doctor, hoping a solid night's sleep and some real food would do just as well for a fraction of the cost. It did.

The following morning, I called the Department of Health in Lihue

continued on outside column of next sightings page



# SIGHTINGS

## mahi — cont'd

to find out if they'd be interested in testing the refrigerated remains of what's come to be known as the 'evil mahi'. "Oooh, yes!" gushed Lab Administrator Jan Ishibashi. We set a time to drop off the fish later in the day.

In the meantime, Rich and Maryann brought over a Cigua-Check fish testing kit they'd picked up at the local fishing supply store. Vaguely reminiscent of a pregnancy test but infinitely more complicated, the test promised to give an "accurate result in less than one hour." Following the instructions to the letter — a process that took much longer than an hour — resulted in the fish testing positive for ciguatera.

But when we mentioned our positive result to the folks at the Health Department, looks were exchanged. "I think those tests are junk," scoffed Jan. Epidemiologist Luke Hasty took a slightly more diplomatic tack. "While I wouldn't say they're *always* wrong," he said, "I wouldn't rely on them." In fact, while the company that makes the tests doesn't offer an official accuracy rate, members of online fishing forums claim that every fish they've ever tested has turned the stick blue, causing them to seriously question the test's usefulness.

continued on outside column of next sightings page

## calling for help

We first ran Newport Beach-based ham guru Gordon West's feature article 'The Idiot's Guide to Marine SSB' in the October '07 issue of *Latitude*. The response to the piece was so tremendous that we ran it again in the fall of '08 and '09, and uploaded the full article to the Features section of our website so everyone could benefit from Gordon's experience.

With the October issue already jam-packed, we didn't have room to run the whole feature this month. So instead of waiting until the November issue, we're running the most important part of Gordon's article — Calling for Help over the SSB — and suggest that you read the full article at [www.latitude38.com/features/SSB.html](http://www.latitude38.com/features/SSB.html).

— ladonna



**A fish tale — Clockwise from here: Rob has caught many mahi, such as this one on another transpacific delivery two years ago, but has never fallen ill; he is also meticulous about filleting and refrigerating his catch; ciguatera is most commonly found in reef predators, such as barracuda, grouper, red snapper, amberjack, and Spanish mackerel, but rarely in pelagic fish, so Jan Ishibashi and Dr. Luke Hasty of the Hawaii Health Department were as eager as we were to find out if the 'evil mahi' was tainted; according to an expensive Cigua-Check test, it was.**

SPREAD & UPPER RIGHT: AARON DUNLAP; OTHERS: LATITUDE / LADONNA

## over the ssb

### Calling for Help over the SSB

Radio signals within the SSB short-wave spectrum refract off the ionosphere and come back to earth hundreds to thousands of miles away without the need for communication satellites and/or ground stations. Each marine SSB radio frequency band has a very predictable skywave bounce 'bulls-eye'. If you choose a band that's too high, your signal will skip over the other station. If you choose a frequency that's too low, your signal won't go far enough to reach the other station.

The following is a good guide for choosing the band of frequencies that will target your first skywave bounce:

2 MHz: 200-400 miles

4 MHz: 400-600 miles

continued in middle column of next sightings page

## mahi — cont'd

Dr. Hasty informed us that the lab testing would take a couple weeks, and would include testing for scombroid, an illness that results from eating decaying fish. "The fish may not be 'bad'," Dr. Hasty said, "but it has a bacteria on it that produces histamine, which is what makes people sick." Though some of the symptoms are similar to ciguatera, even Dr. Hasty admitted that it was unlikely to be the cause of Rob's illness. "From all indications," he told us, "Rob appears to have had ciguatera. And if the test comes back positive, this would be the first documented case of mahi-caused ciguatera in the Pacific."

While we waited for the results, we prepped the boat for the replacement delivery skipper, said goodbye to our new friends Rich and Maryann, and flew home. It's been a month, almost to the day, since Rob's little adventure, and he's now fully recovered, with none of the potential long-term side effects that have been reported by some.

Two weeks after our return home, Dr. Hasty emailed the unsurprising results of the scombroid test: "No detectable level [of histamine] in the specimen," he wrote. But his next email, received just a few days before this issue went to press, threw us for a loop: "I've just received the U.S. FDA ciguatoxin testing report on your fish samples, and the result was negative. Obviously, that begs the question, 'What caused the illness?' I have no answer."

And it seems unlikely we'll ever get an answer. Having limited resources — not to mention far better things to do — Dr. Hasty will not be ordering any more tests. All we know for sure is that something in that mahi made Rob very sick. "I should have known that fish was bad," he said. "As I was filleting it, Metallica's 'Am I Evil' was playing on the stereo . . . really loud."

— ladonna



LATITUDE / LADONNA

Maryann Holden and Rich Jensen didn't hesitate to help a sailor in need.

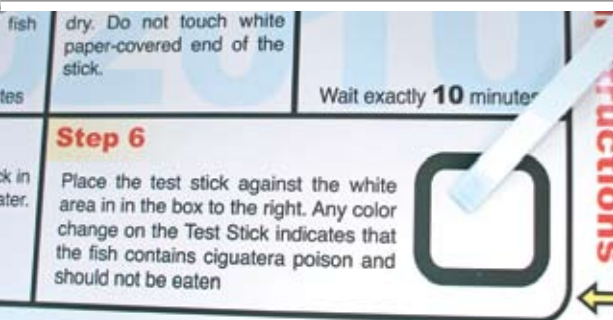

## the america's cup, as you see it

With bated breath, the sailing world has been waiting for months for a definitive announcement regarding the 34th America's Cup. On September 13, it got a little satisfaction with the announcement that the next Cup match will be contested in hard-wing 72-ft catamarans in '13. While there had been plenty of what has turned out to be true speculation in regard to the AC 72 catamaran, the 2013 date was a bit of a surprise, as was the announcement that the new, annual series of traveling events leading up to the Cup — dubbed the "America's Cup World Series" — would start in '11 in a one-design 45-ft hard-wing cat. The AC 45 will allow new teams a chance to come to grips with the new technology before building their custom AC 72s with 130-ft tall wings for '12. Another very pleasant surprise is that, once the AC 72s come online, the AC 45s will be sailed for a "Youth America's Cup."

On the heels of the announcement, we asked *Lectronic Latitude* readers to provide their opinions on the developments. We asked them to tell us what they thought about the use of multihulls, the use of wings, the World Series, and the youth program. We also asked what they thought the Bay's chances are of hosting the next Cup, and we asked them to give their ages and whether or not they'd ever sailed a multihull. The reaction to the use of catamarans was by and large very positive, even from the bulk of the respondents who identified themselves as monohull sailors. Age seemed not to have any bearing on the responses — although half of the respondents declined to state.

- "The America's Cup boats should be absolutely the most unconventional, high-technology, highest-performance, wind-powered vessels ever

continued on outside column of next sightings page

# SIGHTINGS

## america's cup — cont'd

seen by humankind . . . I want the most radical and expensive designs that today's computers can come up with. Period." — Robert Reed

• "If you could drive a faster car than Dario Franchitti, would you watch the Indy 500?" — Sam Minervi

• "I prefer to sail monohulls; but the way multis have been screaming around the planet in the past few years, coupled with the fact that my

8-year-old kid watched the last America's Cup with me, jumping off the couch when BMW Oracle raised up on one ama and peeled away from Alinghi, convinces me that this is the wave of the future."

— Javier Jerez

• "Herreshoff proposed catamarans for the Cup ages ago. Bring on the new tech!"

— Captain Iggy

Some expressed concern that the use of

wings, and to a lesser extent the use of multis, would make it difficult for the sailing public to identify with the race.

• "Cats are great, but 99% of people cruise and race monohulls. Part of watching the competition is to imagine yourself in their positions. I just can't relate to huge fixed-wing cat sailing." — Craig Alger

Father of three young sailors, Tom Price said that while he appreciated multihulls, "there are seemingly significant downstream effects" from the decision.

• "I am curious if our modern sailing luminaries and trendsetters have considered the impact this decision will have on youth sailing programs; namely existing fleet investments. We all know how much the sailing community is struggling to get youth involved in the sport so, at this critical juncture in sailing history, I am concerned our next generation of youth sailors will look at monohull dinghies as 'like, so yesterday.'"

Speaking of youth, the response to the youth circuit was overwhelmingly positive. And at least one reader sees a potential benefit to Generation Y at large.

• "The youth team will help the world if it can get kids' heads out of their iPhone, texting, OMG, WTF lives!" — Gary Lind

The response to the America's Cup World Series was positive almost across the board, but ratings on the probability that the next Cup will come to the Bay were, by and large, below the 50% mark.

Although there were a number of reasons cited, including the AC 72s' being too fast for racing on the Bay, most of the doubts were based on the perceived nature of City politics and the potential for interruption from the "environmental camp."

• "Forty percent. I think Larry and Russell would like it here, but the risk of litigation from even one cranky 'environmental' wacko puts the whole thing at risk." — Rich Jepsen

• "I'm concerned that the prospects for San Francisco's hosting the event may actually be at risk simply because the only real determinant is the City itself, in all its weirdness, which could be thinking that the task is now easier. All the bland reassurances of support by the huge variety of 'parties' may not instill sufficient confidence in anyone who has knowledge of the history in dealing with this gang. I still give it a 50/50 shot, as the venue competitors have equally messy reputations for doing what they say . . . or as stated by Mercurio in Romeo and Juliet, 'A plague o' both your houses!'" — Roving John

continued on outside column of next sightings page

SKIDMORE OWINGS & MERRILL LLP



An America's Cup Village could look like this.

ssb

6 MHz: 600-1200 miles

8 MHz: 800-1600 miles

12 MHz: 1200-2400 miles

16 MHz: 1600-3200 miles

22 MHz: 2200-4000 miles-plus

26 MHz: unpredictable

There are six Coast Guard Global Maritime Distress and Safety System (GMDSS) channel/frequencies:

2182, the distress channel

4125 (4S)

6215 (6S)

8291 (8S)

12,290 (12S)

16,420 (16S)



Melgii madness — Catch all the action from the Melges 32 Worlds in Racing Sheet.

**— cont'd**

The Coast Guard or other international rescue agencies monitor them 24 hours a day. U.S. Coast Guard monitors out of Hawaii, Guam, Alaska, San Francisco, New Orleans, Miami and Norfolk.

Warning! Remember that different bands have different ranges. If you make an emergency call on 2182 when you're halfway between Mexico and the Marquesas, it's very unlikely anybody is going to hear you. If you check the earlier chart, you'll see that you'd actually want to transmit on 12,290 (12S) where the range would be 1,200 to 2,400 miles.

— *gordon west*

**america's cup — cont'd**

• *"I think the tight schedule is a huge challenge."* — Antonio Rico  
At least one respondent wasn't bothered by the drawbacks.

• *"One hundred percent. Bay Area sailors want the Cup to be sailed in the Bay. Larry wants it sailed here, Gavin [Brady] wants it here, the Golden Gate YC wants it here, Latitude 38 wants it here . . . 100%. Let's do it!"* — Pat Ireland

Thanks to everyone who responded. We didn't have enough room to fit everyone's comments, but we appreciate your input just the same. If there's one thing we've learned from this exercise, it's that *Latitude* readers aren't afraid of change. This led us to think that maybe a progressive place like San Francisco is exactly the spot to host the most radical America's Cup ever. We have more particulars on the announcement in this month's *Racing Sheet*, which you'll find on page 130.

—rob



# ROLEX BIG BOAT SERIES

**A**t first blush, the 46th Rolex Big Boat Series appeared rather unremarkable. Absent were the four straight days of breeze into the 30s and sunny skies. Although the 98 boats in four IRC and five one design divisions eclipsed last year's 95 in four and seven respectively, the median waterline got smaller. But look a little closer, and you see that despite these differences, this year's event had some really remarkable aspects that made it every bit the regatta as last year's, if not more.

First of all, the weather, perhaps the most maligned — for good reason — part of this year's event had a silver lining. Despite the fact that the sun didn't show up really until Saturday afternoon, making for an admittedly unphotogenic regatta, the fog, cutoff low, and cooler inland temperatures that provided upper-level cloud cover and made for a gray Bay almost all weekend long, also provided some of the most visitor-friendly conditions in a while. With rare, and highly-variable wind angles, the breeze consistently trumped current as the major strategic factor. And local knowledge? You could throw at least some of it out the window.

Thursday's two races were sailed in pea-soup fog and breeze that peaked at around the mid-20s, which made for some challenging navigating and close calls with other boats and commercial traffic that provided the perfect test.

"Quite honestly we were lucky that a crewmember brought a handheld GPS aboard so that we were able to find marks," said 1D35 division winner Jon Hunt. "We were blundering around, overstanding marks and looking for marks where they were supposed to be, not exactly there. There were fog horns everywhere, it was disorienting, challenging steering with no visual reference, and the ferries and commercial traffic kept appearing out of nowhere. There was big stress in finding laylines, keeping track of competitors, and staying away from big steel bows, but big relief when the finish line came out of the fog."

As the breeze got lighter through the weekend, never getting much higher than the mid-teens, another benefit was that it made for a less physically taxing event.

"You didn't get off the water feeling like you'd been in a heavyweight wrestling match," observed J/120 division winner Don Payan. "Usually, you get off the water and you're black and blue and sore. This was very civilized."

Unfortunately, the weather did make for an abbreviated Bay Tour on Sunday and no race to Pt. Bonita for the second year in a row.

Where last year's headline-grabbing class was IRC A, this year it was the Melges 32s, the only grand prix one design class in America at the moment, sailing their pre-worlds at the event. Along with the IRC A divisions, the 32s provided the bulk of the top-level pros found on the docks, both sailors and coaches, as well as the international flair — the regatta boasted entries from New Zealand, Canada, Mexico, the Czech Republic, Japan and Great Britain. This year marked the first time since probably the Farr 40 days of yore that there was a big concentration of talent present at the Rolex Big Boat Series.

## Melges 32

The Melges 32s represented the smallest boats at this year's Rolex Big Boat Series, but drew the largest fleet, and so sailed



LATTITUDE/ROB

*Stefano Nicolussi, Luca Faravelli, Federico Michetti and skipper Luca Lalli are all smiles after winning the Melges 32 division at the Rolex Big Boat Series; spread, a handful of the 27 boats roll toward Alcatraz on Friday afternoon; inset, hike!!*

DANIEL FORSTER/ROLEX



— GRAND PRIX ALL THE WAY



ERIK SIMONSON/WWW.H2OSHOTS.COM

# ROLEX BIG BOAT SERIES

DANIEL FORSTER/ROLEX



**Mick Shlens and Mark Jones' TP 52 'Flash' pokes a hole through Thursday's gloom.**

for a Rolex and the Commodore's Cup. So how grand prix was this fledgling class for whom the regatta was a warm-up to its second-ever World Championship the following week? Enough that St. Francis YC PRO John Craig had to make an announcement at the skippers' meeting that RIBs would be strictly prohibited from tying up to the guest docks, and that any additional trailers that made their way to the parking lot east of the club and were hooked into the power grid — which incidentally covered every available outlet on that end of the building — would have to keep their cords tidy, because well, there were just too many of each!

Twenty-seven-year-old former 470 sailor, Italian Luca Lalli's *B-lin* — named for a colloquial expression that adorned his first 470 — won the tight division with no local knowledge other than an animated web-based current map aboard. Carrying a one point lead into the final race, Lalli dispatched his closest competition with a bullet in the final race.

"Basically we just tried to control our competition on the starting line," Lalli said. "When [Jeff Ecklund's] *Star* went for the harbor, we knew we had won the regatta."

While doing that without any local knowledge aboard is remarkable in and of itself, it's all the more so when you consider that *B-lin* sails with only basic electronics.

"We don't sail with GPS," Lalli said. "That made it difficult in the fog situation, but we had focused one learning where the stationary buoys were."

Lalli and his crew of Italian aces like

Lorenzo Brassani, Flavio Favini and Melges Europe's Federico Michetti along with Stefano Nicolusi, Luca Faravela, Carlo Zermini and Lorenzo Del Rio reigned supreme in a class replete with America's Cup, Volvo Ocean Race and Olympic talent. Talent like

Stu Bannatyne, the Wilmot brothers, the Greenhalgh brothers, Jonathon McKee, Morgan Larson, Tony Rey, John Lovell, Scott Nixon, Chris Larson, Gavin Brady, and on, and on, and on, and on. The coaching ranks were just as star-studded with people like Dee Smith, Trevor Baylis and Dave Ullman following their charges around in RIBs all weekend long.

There were so many good sailors in

*Spread, 'Vincitore' and 'Wasabi' cross tacks; inset left, Dale Williams with the spoils of victory; inset middle, Colin Booth and Jim Mitchell join Ricardo Brockmann and 'Peligrsoso' owner Lorenzo Berho for the official hand-over; inset right, Jorge Ripstein's 'Patches' made 'Vincitore' work for it.*

the class that some of them had to finish deep, and you'd be surprised to see where many of them ended up. The top local boat was John Kilroy Jr.'s *Samba Pa Ti* in seventh place, while Don Jesberg's *Viva* ended up in 11th, Philippe Kahn's *Pegasus MotionX* in 14th, and Stephen Pugh's *Taboo* finished in 16th.

But all those big names didn't seem to bother Lalli, who works for his family's construction business.

"We know we aren't slow, and we're happy about that," Lalli said. "Next week, we go to the World Championship, and we know we can win."

Turns out, he was right, and you can see the pictures in this month's Racing Sheet.

## IRC A

While not large at only five boats, IRC



LATITUDE/ROB



LATITUDE/ROB



DANIEL FORSTER/ROLEX



# — GRAND PRIX ALL THE WAY

A was a high-quality fleet that featured some truly grand prix programs that hailed from the U.S., Canada, Mexico, and nominally New Zealand. The biggest boat in the regatta, Lorenzo Berho's Kernan 68 *Peligroso*, was never able to shake the 52s that made up the rest of the division. Defending champion Jim Mitchell and his electric blue R/P 52 *Vincitore* were back to defend their title against last year's runner up, Mark Jones and Mick Shlens' TP 52 *Flash*, Ashley Wolfe's TP 52 *Mayhem*, and Rolex Big Boat Series newcomer Jorge Ripstein and his TP 52 *Patches*.

Mitchell, a Chicagoan now based out of Geneva who races only in North America and sails under the burgee

of the Royal New Zealand Yacht Squadron, left no stone unturned in defense of his trophy. Mitchell recruited an all-star crew that included talent like helmsman Chris Dickson, project manager Rodney Keenan, boat captain Colin Booth, Rodney Daniel, Scott Beavis, Bob Wylie, Jamie Gale, Hayden Goodrick,

Martin Hannon, Simon Minoprio, and Jack To-liver. They were joined by Andres Soriano and Ricardo Brockmann.

That turned out to be a good call, as just like last year, the division win — with it a Rolex and the St. Francis Perpetual — came down to the last race of the regatta. Going into Sunday's race, *Vincitore* and the Reichel/Pugh-designed *Patches* were tied on points at 12 apiece after a wild series. With former match racing world champion and Louis Vuitton Cup skipper Peter Holmberg calling the shots and some of Southern California's best, like Bruce Cooper, Steve Dodd, Keith Kilpatrick, and Erik Shap-

main, backing him up, Ripstein steered his new-to-him and newly-IRC'd boat to four straight bullets after a DSQ in Race 2, setting the stage for a dogfight that saw the two boats launch into a tacking duel shortly after the start on the Cityfront course: *Vincitore* gained the advantage off the starting line and only looked back to make sure they were between their competition and the next shift, finishing the race 30 seconds ahead of *Patches* on corrected time.

"Usually you plan it all out and it doesn't happen like you want it to," Dickson said. "This was one of those times that it worked out. Having said that . . . they still had a good shot at it. At the last mark with all that work done, we still needed to make up 10-15 seconds on our time to beat them."

Just like last year, Mitchell was quick to point out that as sweet as the win was, it was all the better that his dad, who got him into sailing, was there to see it again, watching the racing from a chase boat.

"I've had three great years of memories here with my dad," he said.

Still, Mitchell said the win was bittersweet, as it was his last regatta with the three-year-old boat. Acapulco-based Brockmann — a longtime campaigner, Most recently in his Concordia 47 *Ruahatu* — made Mitchell an offer that was too good to refuse, with the hand-over planned for the conclusion of racing. Mitchell said he'd been playing around with the idea of going slightly bigger when he got a call out of the blue.

"Ricardo contacted me and said, 'I really love your boat, and I want to buy it,' and that made up my mind," Mitchell said.

Mitchell explained that in anticipation of a crop of TP 52s coming to North America, he and his team analyzed what would make the most sense, and 55-feet seemed to be about the right size for buoy racing, his beloved Mackinac races, and

**Robbie Haines and Dan Woolery make a winning combo on 'Soozal'. The duo have won the West Coast IRC Championship two years running.**



LATITUDE/ROB

maybe a TransPac in the future.

"It should give us a little more speed off the starting line to get clear of everyone else, and be just that much faster offshore," he said.

Construction on the new boat is already underway at Davie Norris Boat-builders in Christchurch, New Zealand — which came through the recent 7.1 earthquake unscathed — and with a projected launch date of June. Mitchell said that though it will be tight, there's a good chance he'll be at next year's Rolex Big Boat Series with his new steed.

*Patches* — which seemed to excel in the lighter air on Friday, Saturday and Sunday — proved to be very competitive, remarkable given the timeframe Ripstein had to prepare her. The boat's first race was the Santa Barbara to King Harbor Race in early August. Immediately after she was hauled, her keel bulb was sent to Mexico to have another 800 pounds added to it while she was being reconfigured for IRC with split topmast backstays and a squaretop main that was purchased on E Bay from the Russian Audi Med Cup team. Finished just in time to make the trip north, the boat proved to be just the right weapon for Ripstein, a seasoned campaigner who has owned some of the West Coast's most storied race boats such as *Nitissima*, *Persephone* and most recently, the ILC 46 *Wasabi*.



DANIEL FORSTER/ROLEX

# ROLEX BIG BOAT SERIES

## IRC B

Sailing for the City of San Francisco Perpetual Trophy, IRC B turned out to be a competitive division despite great disparity in the age range of the seven boats that contested it. Dan Woolery and his Pt. Richmond-based King 40 *Soozal* dominated their division as they've done in just about everything they've entered since the boat was launched in January of last year. Woolery and tactician Robbie Haines were so good, in fact, that they wrapped up the regatta with a day to spare, although it didn't stop them from going out for fun on Sunday.

"If you come out to race, you don't backpedal," Woolery said. "So we decided to go out and stay out of everyone's way, since there was a three-way tie behind us. But, we ended up right in the middle of everyone anyway."

Woolery had many of his regulars aboard, including Gary Sadamori, Greg Felton, Chris Lewis, Dave Gruver, Matt Siddens, Andy McCormick and Pete McCormick. Conspicuously absent was project manager Scott Easom, who had already committed to one of his other projects, Lani Spund's *Kokopelli*<sup>2</sup>.

As it turned out, *Koko* finished the regatta in second, breaking a three-way tie despite not being an IRC design and having been designed about 17 years prior to *Soozal*. Amazingly enough, the boat *Koko* beat was the '85 Reichel/Pugh 47 *Flyer*, successfully campaigned on the Bay by Bill Twist in the IOR heyday under the *Bladerunner* livery. The classic speedster, unlike a lot of boats from her era, is in great shape beat a purpose-built IRC racer, an IRC-optimized Farr 40, an IRC-optimized IMS boat and an IMS boat to finish on the podium — pretty impressive

**'Masquerading' as 'Arbitrage' — due to a recalcitrant rudder bearing, Bruce Stone drove a borrowed boat to victory in the J/105 class.**

for a true warhorse from a bygone era.

After his two years of beating the pants off all comers, we asked Woolery what he had planned next now that he's carted off the West Coast IRC Championship for the second year running.

"We got a slip down in Dana Point, so the boat is going to get a coat of bottom paint, the roller furling gear will go on and we're going to do some cruising in Southern California over the winter," Woolery said. "After that we may head to the Florida regattas next winter after Big Boat Series, depending on the economy. It doesn't make much sense to take the boat over there if there aren't going to be many boats."

Although he wouldn't commit to it, he said there's chance he may go bigger.

"I've been thinking about a 52," he said, "I haven't made up my mind yet. But I would really like to keep this great crew together."

## IRC C

The Richard Rheem Perpetual went to IRC C this year, and in somewhat of a departure, the division was organized not around a particular rating band, but rather a typeform: ultralight sportboats under 50 ft that typically struggle under IRC. After sailing as a David among Goliaths last year and still coming in second, Dale Williams' Kernan 44 *Wasabi* was the Goliath in her division this year, racing against a pair of J/125s, a pair of Farr 36s and a Santa Cruz 37. *Wasabi* lived up to her billing as the scratch boat, scoring straight bullets to close out the series with an extraneous one.

"It was never in the bag," Williams said. "When you're racing on San Francisco Bay, you are never secure."

As it turns out, *Wasabi* only walked away with one race, and finished a little over a minute ahead of the next boat in another. The rest were all within about 45 seconds, due in no small part to a crew that included Craig Fletcher, Richie Eggerman, Steve Baumhoff, Garrett Greenhalgh, Drew Harper, Kernan, David Oborn, Malcolm Park, Pete Heck, Greg Williams and tactician Kevin Miller.

At the trophy presentation, Williams made special mention of his



DAVE KEANE/WWW.DAVEKEANE.COM

**The J/105s soak downwind in the mellow (but finally sunny) conditions on Sunday.**

late friend and boat partner Mike Campbell — with whom *Wasabi* was started a couple years ago — dedicating the win to him and saying that it was the realization of "a dream" they had shared.

While it may not have been Williams' last regatta with the boat, he's already got a new one in the works — a 54-footer from Kernan.

## IRC D

Tom Brott probably never thought he'd go home with a Rolex after his first Big Boat Series, but the Long Beach-based J/109 sailor did just that by winning the seven-boat IRC D division. In the process, Brott not only got his name on the Keefe-Kilborn Perpetual, but dethroned the division's defending champ in the process.

"The lighter air really helped us," he said, explaining that *Electra* was rated with her overlapping headsails, whereas most Bay Area boats get rated without them because they get used so little in Central Bay racing.

But the winning effort nearly didn't get underway for Brott and his crew of tactician Harry Pattison, Leslie Baehr, Tom Parry, Will Vrooman, Jay Doerrer, Paul Corrigan and Mike Crawford, when a jib halyard snafu during race one left



DANIEL FORSTER/ROLEX

# — GRAND PRIX ALL THE WAY



nial perch as the largest one design class this year, but not by much. Twenty-four of the Bay's top boats showed up to compete for the Atlantic Perpetual trophy and a Rolex, and as can be expected, there were no freebies. The top bullet-getter was Scooter Simmons' *Blackhawk*, but the adage that consistency wins regattas proved true for Bruce Stone's *Arbitrage*. Stone, last year's runner-up, scored only one bullet the entire regatta — in the first race — but counted nothing lower than a seventh to finish six points clear of *Blackhawk*.

That kind of consistency would be remarkable in and of itself, but given the fact that Stone and his tactician Brent Draney and crew Stu Johnstone, Julia Lankford, Bob Dearborn and Mike Strauss had to do it on two different boats makes it all the more remarkable. After winning the Bay's J/105 season with sticky rudder bearings, Stone decided to

replace them before the Rolex Big Boat Series. On day one, the replacements had become so stiff that Stone was able to steer downwind with only his hip. *Arbitrage* was up to the task and Stone managed to score a 1-4, but by the end of the day felt he had to make a change.

"I called (previous national champion) Tom Coates, and the first thing he said was, 'don't tell me you broke your boat!'" Stone said.

Coates offered up his *Masquerade* to the *Arbitrage* crew. Stone said they had a diver check the bottom and the report was encouraging, so they set about tuning the rig and crossed their fingers. "We went out and got a 2-3 on Friday, so we felt pretty good about our chances after that," he said.

Stone, who races J/105s on both coasts, incidentally won not only the Bay's Fleet 1 championship this year, but also Newport, Rhode Island's Fleet 14 series, thus consolidating the titles for at least a year.

Perennial contender and defending champion Chris Perkins hadn't sailed his *Good Timin'* all year long as he'd been working for BMW Oracle Racing as their CFO and spending any free sailing time qualifying for the IKC back in August. After a Z-flag penalty in the first race, Perkins managed to claw his way back into fourth, just behind Jeff Litfin and John Case's *Mojo*, while Rolf Kaiser's *Donkey Jack* rounded out the top-five.

## J/120

The J/120s can always be counted on

them with a DNF to start the event.

"With a DNF in that first race, we were coming from behind the whole regatta," Brott said "But, it was having a great crew, and Harry, and being able to concentrate on driving that did it."

Going into the last race, Brott and his team needed only to put a boat between them and defending champion Gerry Sheridan's *Tupelo Honey*. They ended up getting two boats between them to eke out the win in the incredibly tough division where the top-three finishers were separated by only one point.

## J/105

Due to the abundance of Melges 32s, the J/105s were knocked off their peren-

**Chris Boome, left, and Kame Richards sailed 'Golden Moon' to a convincing win in the Express 37 class; the Expresses box-in the R/C boat.**



LATTITUDE/LADONNA



KATY WEBER

# ROLEX BIG BOAT SERIES

to provide one of the closest divisions in the Rolex Big Boat Series, and this year was no exception. It did however break from tradition in a couple ways. First, unlike the last three years running, where the regatta has come down to the final leg of the final race, this year's winner was neither Steve Madeira's *Mr. Magoo* or Barry Lewis' *Chance*. In the second major change for the class, it was Don Payan's *Dayenu* that walked off with the title.

"I've lost on a tiebreaker and been second or third before, but this was the first time I've won as owner," Payan said. "It was a fun regatta and it was such a thrill to win it finally after all these years of being the bridesmaid."

Payan and tactician Peter Cameron's victory was pretty emphatic: three bullets and nothing lower than a fifth over seven races in the eight-boat division.



**Tom Brott sailed his J/109 'Electra' to a win in IRC D in his first Rolex Big Boat Series.**

"The trick in the Big Boat Series is consistency," he said. "This fleet is so competitive, you cannot expect to win it if you have a bad race. For the first time

we were very consistent."

But while *Dayenu's* scores may have been consistent on paper, they required a lot of fighting to get that way. Payan cited Saturday morning's race as an example.

"We had to do a penalty turn shortly after the start and were in seventh around the last weather mark," he said. "Peter made an amazing call to stay right and deep. Uncharacteristically, I kept my mouth shut, and we went from seventh to second. When we did that I said to myself, 'we can win this thing.'"

Cameron, local rigger and electronics specialist who counts in his resume serving as boat captain aboard the late Irv Loube's *Bravuras* and Bob Garvie's *Bullseye* was a late pickup on an established crew that included Steve Bates, Tom Warren, John Verdoia, Michael Cal-

## 2010 ROLEX BIG BOAT SERIES RESULTS

YACHT	OWNER	YACHT CLUB	1	2	3	4	5	6	7	TOTAL
<b>IRC A</b>										
1. <b>Vincitore</b>	Jim Mitchell	Royal New Zealand YS	1	1	3	2	2	3	4	16
2. <b>Patches</b>	Jorge Ripstein	Acapulco	2	6/DSQ	1	1	1	1	5	17
3. <b>Flash</b>	Mick Shlens/Mark Jones	King Harbor YC	3	2	2	4/SCP	5	2	1	19
<b>IRC B</b>										
1. <b>Soozal</b>	Dan Woolery	Richmond YC	4	1	2	3/SCP	1	2	1	14
2. <b>Kokopelli<sup>2</sup></b>	Lani Spund	Royal Ocean Racing Club	5	2	5	5	3	1	2	23
3. <b>Flyer</b>	Rob Sjostedt	Corsair YC	2	4	1	3	7/SCP	4	3	24
<b>IRC C</b>										
1. <b>Wasabi</b>	Dale Williams	St. Francis YC	1	1	1	1	1	1	1	7
2. <b>August Ice</b>	Richard Ferris	Tahoe YC	3.5	3	3	2	2	3	2	18.5
3. <b>Double Trouble</b>	Andy Costello	Corinthian YC	2	2	2	3	3	2	7/RAF	21
<b>IRC D</b>										
1. <b>Electra</b>	Tom Brott	Seal Beach YC	4	8/DNF	1	1	2	1	2	19
2. <b>Tupelo Honey</b>	Gerry Sheridan	South Beach YC	1	4	3	4	1	2	5	20
3. <b>Hawkeye</b>	Frank Morrow	USNA Squadron	3	1	2	6	3	3	3	20
<b>MELGES 32</b>										
1. <b>B-lin Sailing</b>	Luca Lalli	CN Marina di Carrara	5	3	4	3	18	1	1	35
2. <b>Bliksem</b>	Pieter Taselaar	New York YC	2	1	8	2	19	7	8/ZFP	47
3. <b>Red</b>	Joe Woods	Royal Torbay YC	1	12	6	5	14	5	8	51
<b>J/105</b>										
1. <b>Arbitrage</b>	Bruce Stone	St. Francis YC	1	4	2	3	5	7	5	27
2. <b>Blackhawk</b>	Scooter Simmons	San Francisco YC	5	1	4	11	1	10	1	33
3. <b>Mojo</b>	Jef Litfin/John Case	NA	4	2	7	4	12	5	7	41
<b>J/120</b>										
1. <b>Dayenu</b>	Don Payan	St. Francis YC	3	1	5	1	2	1	2	15
2. <b>Mr. Magoo</b>	Steve Madeira	St. Francis YC	7	2	1	3	1	4	3	21
3. <b>Desdemona</b>	Barry Lewis	San Francisco YC	1	5	2	4	3	2	7	24
<b>EXPRESS 37</b>										
1. <b>Golden Moon</b>	Kame Richards/Bill Bridge	Encinal YC	2	1	1	2	3	1	1	11
2. <b>Eclipse</b>	Mark Dowdy	San Francisco YC	1	4	3	3	1	3	4	19
3. <b>Elan</b>	Bill Riess	Richmond YC	4	2	6	1	2	2	7	24
<b>1D35</b>										
1. <b>Dark and Stormy</b>	Jon Hunt	SSS	1	2	1	1	1	1	1	8
2. <b>Ebb Tide</b>	Masakazu Toyama	Seabornia YC	2	1	5	4	2	5	4	23
3. <b>Zsa Zsa</b>	Stan Glaros	Corinthian YC	5	3	3	5	3	2	3	24

# — GRAND PRIX ALL THE WAY

COURTESY DAYENU



The 'Dayenu' crew — front row from left, Tom Warren, Kurt Hemmingsen; second row, from left, Peter Cameron, Debra Hong, Don Payan, EJ Rowland, Steve Bates, Jeff MacDougall, Mike O'Callaghan, John Verdoia, and Randy Smith; right — 'Dayenu' soaking downwind.

lahan, Kurt Hemmingsen, Debra Hong, Jeff MacDougall and EJ Rowland.

"Our regular tactician moved back east, during the final stretch of the season," Payan said. "We said, 'what are we going to do?' I called Peter, who came on for Aldo. The crew was skeptical of breaking in a tactician that late in the season, but he's been great. He's very good at the coaching element of tactics and he has really high standards."

Even so, like any tactician, Cameron wasn't right all the time. At the start of the final race, he thought that *Dayenu* was over early and wanted to restart, but Warren, who was up on the bow, disagreed.

"Peter said, 'we're over,' and Tommy yelled back and said, 'we're not,' and Peter said 'we're over,' and Tommy yelled back again and said 'we're not.' All the boats around us were laughing."

Knowing they had to get only a fifth or better to win the regatta, they sailed conservatively for the rest of the race, and still ended up finishing second.

## Express 37

While the headline-grabbing might have come from the newest one design class at the Rolex Big Boat Series, you just can't beat consistency, and '10 marked the 20th year the Express 37s have participated as a class in the Rolex Big Boat Series. After two straight years of this class's winner getting a watch, it was the Melges 32s' turn this year. So it shouldn't have been too much of a disappointment for Kame Richards' *Golden Moon*, which repeated as the division's winner, picking up his fourth title in eight years.

"We look mean and obnoxious on paper, and in reality we're quite polite,"



DANIEL FORSTER/ROLEX

Richards said.

On paper Richards and his crew, which included boat partner Bill Bridge, Aimee Daniel, Andrew Hura, Brad Jeffrey, Eliza Paulling, Jeannette Daroosh, Mike Mannix, Todd Hedin, Tom Paulling, and guest tactician Chris Boome, won their division convincingly with a 2-1-1-2-3-1-1 to finish eight points clear of Mark Dowdy's *Eclipse*. Richards was quick to attribute that to his crew.

"I was looking at all the YRA and Wednesday night races we did and a huge percentage of our crew sailed everything. Everyone had done everything together over and over so the mechanics of sailing the boat were delightful. We had exactly one guest, and that was Chris, and he's really good."

Another helpful guest was a brand new touchscreen chartplotter.

"On the first two days it was wonderful," Richards said. "We never would have done that well without that piece of equipment, and the best thing is that you can figure out how to make it work without getting the manual out."

*Golden Moon* carried three new sails, which Richards, whom you probably know owns Pineapple Sails in Alameda, said didn't hurt.

"We replaced the main, which I didn't

feel bad about because it would have been its seventh Big Boat Series," he said.

Although the class's numbers were down by one, Richards said that it worked out in his favor. Perennial campaigner Mick Shlens, who typically races his well-sailed *Blade Runner* and came on strong last year to finish just two points shy of *Golden Moon*, has been chartering Mark Jones' TP 52 *Flash* throughout the year, and sailed the latter boat this year in IRC A.

"I thanked him profusely for sailing in the 52 class," Richards said.

## 1D35s

The 1D35 division slipped in attendance this year, with two-time winner Gary Boell having moved on to a Flying Dutchman. In his place, class newcomer Jon Hunt wasted no time in assuming the role of division winner, posting five bullets and a second in the seven-race series to wrap up the title with Sunday's race to spare. Although they didn't need to leave the dock on Sunday, Hunt's crew aboard *Dark And Stormy* sailed the last race for good measure and won it too!

"We had a memorable and remarkable Big Boat Series," Hunt said. "Our crew worked flawlessly and we had a bit of extra speed every now and then thanks to

# ROLEX BIG BOAT SERIES

our trimmers, who were constantly working to find something extra. As helmsman I still have 'two degrees up!!,' 'one degree down!!,' 'right there!!,' and, 'shut up and concentrate!!' ringing in my ears."

Hunt didn't pull any punches in recruiting a high-level crew, getting Olympic coach Rodney Hagebols to call the shots for the team of Nedko Vassilev, Howard Bentley, Kim Stuart, Michaela Draper, Sherry Smith, Ron Wizelman and Tone Chin.

"We won our class by getting good starts, not engaging in useless boat for boat confrontations, working on boat speed on the first weather leg, rounding the weather mark leading or in the top 2-3, and then defending downwind," Hunt said.

He's only had *Dark And Stormy* for 1.5 years, and said he's been sailing slower boats, "but not at this level," for at least 15 years. His result suggests he's a quick study, and he seems pretty happy with the boat.

"The 1D is the best speed for the dollar available on the used boat market as far as I am concerned," he said. "There

is some good one design racing, good camaraderie and cooperation amongst the owners, a large loyal crew pool, and it has a carbon mast that can be turbo'ed. It's an older design that's still on the leading edge and available for less than \$100K."

Returning for a third year in a row was Masakazu Toyama's *Ebb Tide* team from Japan. A crowd favorite at the awards ceremony, the always-smiling Toyama and his team narrowly beat Stan Glaros' *Zsa Zsa* to defend their runner-up title from '09.

**T**he Rolex Big Boat Series is the bellwether big boat regatta on the West Coast and the signals it put out were pretty positive. There are new boats on the way, and at least one of those will be replacing a competitive boat that will stay on the West Coast.

There are also a couple new projects in the 40-plus-ft range slated to come online pretty darn quickly, which is a great sign. The presence of Big Boat Series newcomers bodes well for the

future of the event also; hopefully the fact that some of them enjoyed success will encourage other to take the plunge and join the fun. Right now it seems as though half the SoCal 52 fleet is for sale, and if those boats ever get in the hands of people who want to sail their planing boats at planing speeds, then we could see a viable revival of the TP 52 in its most perfect venue.

But as much as the "new" is essential for the growth of the event, the continued presence of the Rolex Big Boat Series stalwarts provides the base on which the regatta can build. And the stalwarts not only showed up this year, but in many cases really ramped up their programs.

Certainly a big challenge for the organizers will be to offset the loss of the Melges 32s, which although likely to come back, probably will not do so in the numbers seen this year. But given the St. Francis YC's track record with finding solutions, the gray gloom may have occluded marks and ferries, but it hasn't occluded the Rolex Big Boat Series' bright future.

— **latitude**/rg

CUSTOM GEAR FOR YOUR REGATTA OR TEAM

**BIG BOATS**  
LITTLE BOATS

**BIG EVENTS**  
LITTLE EVENTS

*We've got you covered!*

**PIRATES + LAIR**  
WWW.PIRATESLAIR.COM  
CALL: 888.SAIL.BUM

Gill Hanes Pro-Fit GILDAN PORT AUTHORITY

T-SHIRTS & CAPS  
POLOS & SHORTS  
SCREEN PRINTING  
MOISTURE WICKING  
DYE-SUBLIMATION  
TECHNICAL GEAR  
EMBROIDERY  
DESIGN

OFFICIAL GEAR SUPPLIER  
MOUNT GAY RUM  
BARBADOS  
WWW.PIRATESLAIR.COM

CUSTOM REGATTA GRAPHICS HERE

©2010 Mount Gay Distilleries Ltd., Mount Gay® Barbados Rum, 40% Alc/Vol., Imported by Rémy Cointreau USA, Inc., New York, N.Y. Eclipse Design™ Be Confident. Drink Responsibly.

# Electrifying Results!

## 1st and 2nd in the most competitive Rolex Big Boat Series IRC class



Results on the race course are testament to the quality of the boat, the crew and the pre-race preparation...

### Results in IRC B:

<i>Soozal</i>	Dan Woolery	First Place
<i>Kokopelli<sup>2</sup></i>	Lani Spund	Second Place

Both boats prepared by Easom Rigging with electric hydraulics and electric winch packages.

"Soozal is the best IRC boat on the planet."  
- Norman Davant



*Kokopelli<sup>2</sup>*



*Harken electric winch*

Congratulations to Dan Woolery and his crew on *Soozal* and Lani Spund and the crew of *Kokopelli<sup>2</sup>*.

Let us show you how easy it can be to sail the Bay.

### Easom Racing and Rigging

1150 Brickyard Cove Rd. Suite B1  
Point Richmond, CA 94801

**(510) 232-SAIL (7245)**

[www.easomrigging.com](http://www.easomrigging.com)



# PASSIN' THROUGH

Every fall, the Bay Area brims with visitors — tourists in the City, migrating birds in the trees, and cruisers on the Bay. The latter group is an eclectic bunch. Some have gleaming new, factory-finished yachts, others sail older but still serviceable production boats, and a handful are kickin' it old-skool with owner-built beauties.

In the following pages, you'll meet the crew of seven transient boats that passed through the Bay Area last month, and you'll find their cruising styles are as diverse as their boats. From the Norwegian couple who've sailed halfway around the world on a pocket cruiser to the French family who've made the same journey on a luxury catamaran. From the folks whose trip down the coast from Victoria was their first offshore passage to the Vancouver-based couple who sailed to Chile, spent a winter on the Beagle Channel, returned to Vancouver, and are once again on their way south. Though their stories are different, they're all fascinating.

Over the next couple months, if you find yourself anchoring next to someone with a distant hailing port or a foreign courtesy flag, take a moment to welcome them to San Francisco Bay. If you see a new boat in your marina's transient slip, offer them a ride to the grocery store or West Marine (something *always* breaks on the way down the coast). By all means, invite them over for a cup of tea or a cold brew. But remember that these folks are on 'cruising time' — which just means that you'll be highly entertained by real-life sea stories for as long as you have available. That's never a bad thing!

— *latitude*/ladonna



**Karina C**, Spencer 35, Nanaimo, B.C. — Some cruisers have saltwater running through their blood; Jay and Anita Bigland have music running through theirs. A retired music teacher, Jay started sailing on a Thunderbird in the early '80s. Over the years, the couple traded out boats, finally settling on *Karina C* in '01. "We lived in Prince George and would spend our summers on the boat," Jay explained, as he pulled out his Martin backpacker guitar. "Anita and I are lifers — married 34 years," he continued, plucking a few strings absentmindedly. "This is what she said to me on our first date . . . ." and he started playing 'Dream a Little Dream' as Anita sang along.

But it was, in fact, Jay's dream to go cruising. "He said to me, 'Wouldn't you like to get away from the cold and snow?'" recalled Anita. "I suggested getting a condo in Palm Springs, but he said that would be too expensive, and that it would be so much cheaper on our own boat. We've never spent so much money as we did refitting *Karina*!"

"When some people go into an old folks' home, they wonder 'what if,'" Jay said by way of explanation. "I'm not going to wonder. But we're more concerned with each other than with the boat, so if either one of us said we were done, we'd stop."

*Karina C* is entry #161 in the Baja Ha-Ha, which kicks off at the end of this month, and both say they're really looking forward to it. "We'll probably leave the boat in Mexico and commuter cruise for awhile," said Jay. When asked what got him interested in sailing in the first place, Jay said that they'd been on their powerboat many years ago when he looked out and saw a bunch of sailboats plying the waters of Howe Sound. "I turned on the radio and this was playing . . . ." We were once again serenaded, this time to Christopher Cross's classic 'Sailing'.







**Comocean**, Catalina 42, Blaine, WA — Gary and Sonia Hurt believe in living their life by design. "I got this book on tape called 'Life By Design' and it really changed my life," said Sonia. "The basic premise is to figure out what you want in life — in our case, it was to go cruising — and then every decision you make from that point on is made with your end goal in mind." The Hurts worked up a seven-year plan that included buying a boat, selling their house, and quitting their jobs — Gary's as a database administrator, Sonia's as a marketing director.

First came the boat, which they bought in Anacortes in '01. "We put it in charter while we still lived in Sonora," Gary explained. "With what we saved in taxes, it really worked for us." Next came paying off the boat, which meant selling their house. "I started selling all our stuff years before the house sold," laughed Sonia. "She became an eBay Power Seller," added Gary. Then, in '07, they retired — though Gary still consults for the same company — and moved to Washington to live aboard full-time. "It's funny," said Sonia. "We lived in Sonora for many years and had just a handful of friends. In just six months, we had more friends in Blaine than we ever had in California."

The Hurts chose an excellent weather window to make their way down from Neah Bay. "We came down nonstop; it was our first overnight passage," said Gary. "We had a wonderful beam reach till we reached Reedsport, and the wind just died." Consequently, they're among of the handful of cruisers who didn't have any breakages on the trip south.

As for their future plans, they say they'd originally planned to cruise six-and-six. Not the typical six months in Mexico, six months at home — remember, they'd sold the house. No, they were going to spend waii for summers. "But after the five days of no sleep coming down here," said Sonia, "this might be a once in a lifetime trip." But don't give up on them yet. As Gary noted, "you may get used to it."

**Bika**, Contessa 26, Stavanger, Norway — Two weeks after being turned down for a home loan in '03, Henrik Nor-Hansen and Nina Nilsen bought their 26-ft *Bika* thinking she'd be a starter boat. "But then we began reading about pocket cruising," Henrik recalled, "so we decided to stay with *Bika*." Originally planning a three-year cruise, the couple set out from Norway in '05 and haven't looked back.

That's not to say they haven't strayed from *Bika* on occasion. "We haven't been on the boat the entire time," said Nina. "We go back to Norway for a few months at a time so I can work [as an environmental engineer]. One winter, we spent eight months caretaking an isolated cabin in northern Canada, and we hope to spend this winter housesitting in Anchorage." (As a novelist and poet, Henrik can work anywhere.)

In fact, it's been more than a year since their last big ocean crossing, which was a particularly rough trip from the Bahamas to Cape Hatteras. "We saw five waterspouts in one day," recalled Henrik. "It was raining so hard that the seas were flattened."

Surviving the deluge, the couple spent some time exploring America aboard *Bika*, from the Great Lakes to Texas. There they completed a major refit. But instead of taking the time and expense to sail the little red boat through the Panama Canal, they put her on a truck bound for the Bay. "It was much cheaper," said Henrik, "plus I wanted to see San Francisco."

*Bika* and her crew arrived in May, spent some time in the driveway of a friend's Central Valley home working on a few leftover projects, and have been bouncing around the Bay for the rest of the summer. They left last month, bound for Mexico and, ultimately, Norway.

When asked about her favorite place visited during their trip so far, Nina hedged. "I don't like saying I have a favorite because that takes away from all the other wonderful places we've been. But I will say that Morocco was the biggest surprise — the people were super friendly — and we've really fallen in love with the Bay. Sailing here is serious business. For us, San Francisco is a very inspiring city and we can't wait to come back."



# PASSIN' THROUGH

ALL PHOTOS LATITUDE / LADONNA

**Riki Tiki Tavi**, Coast 36, Victoria, B.C. — A homebuilt boat is always impressive — all those long hours! — even if it isn't very pretty. But when it's as beautiful and well-built as Ray and Marnie Summers' *Riki Tiki Tavi*, you just have to sit in awe. "I built her from scratch — laid up her hull in a one-off mold — over the course of seven years," said Ray, a retired industrial tool designer, adding that he stretched the original design by two feet. Asked if he felt building the boat himself was worth it, Ray said "We saved about 50% but I'd never do it again — next time I'd just buy a production boat!"

Having spent the last four years cruising the Gulf Islands and dreaming about warmer lands, Ray and Marnie decided to fully commit to the cruising lifestyle by selling their home. "We didn't want to wait around on the porch waiting for the kids to come around," laughed Marnie.

They set off on their first offshore passage early last month, intending on a non-stop trip to San Diego before spending the winter in Mexico then heading off to the Marquesas and, ultimately, New Zealand. "We didn't mean to pull in to San Francisco Bay," said Ray, "but we were battered by a storm a week ago and some things broke."

They planned on spending a couple weeks in the Bay, working on the boat and recuperating from their beating. "It was so bad at one point that Ray told me to draw the drapes and to not look out," Marnie recalled with a smile. "I said this better not happen again or I'm selling the boat and getting a Winnebago!"



**Bravo**, Kelly Peterson 46, Seattle — Some trips down the coast are more exciting than others. Count *Bravo's* among the former. Adam and Cindi Kerner left Seattle's Shilshole Marina bound for Coos Bay with crew Mike and Kirk aboard. Adam, Cindi and Mike had taken seasickness meds, but Kirk, an experienced offshore racer who'd never been seasick in his life, chose not to. Unfortunately, a beam sea proved too much for Kirk's iron stomach and he succumbed.

"We were concerned about him getting dehydrated," said Adam, "so we made sure he was getting plenty of electrolyte replacements." Then in the middle of the night off the Oregon coast, Mike called Adam down below — Kirk was passed out and lying halfway in the head, half out. "At first we thought he might have fallen and hurt his back," recalled Adam, "but when I saw the little cartoon Xs in his eyes, I realized we had a real problem."

Assuming Kirk was suffering from extreme dehydration, they headed straight for Newport. Cindi escorted him to the hospital, where he was put on two IVs. But when he didn't perk up — which usually happens almost immediately — the ER staff did a blood work-up. That's when the red flags started flying.

"His blood hematocrit level was half what it should have been — he was bleeding



**Kir-Tidou**, Privilege 495, Les Sable d'Olonne, France — For the past eight years, the Bonnefille family — parents Thierry and Dulce, and kids Mathieu and Eva — have cruised halfway across the globe aboard *Kir-Tidou*, and have loved every minute of it. "We left when Matt was six and Eva three," said proud papa Thierry. The Bonnefilles left their then-homeport of Belgium in '02, and took their time exploring their way across the Atlantic to Brazil. "We didn't want to miss anything," Thierry laughed.

But not all of their journey has been by boat. Once they arrived in South America, they rented an RV to explore inland. "We spent six months in the motorhome exploring Argentina, Bolivia, Peru, Chile," Thierry said. "We even drove the motorhome onto a ferry and 'sailed' the Patagonian Canals."

Having slowly worked their way north through the Caribbean, the family spent two months in Cuba. "For us, it was a fantastic trip," Thierry said. "We met incredible people, and found they have top-notch education and medical facilities." But he noted that life is very difficult for Cubans. "The man who cleaned my boat for very little money was a nuclear engineer."

From there, the Bonnefilles sailed to Puerto Rico, Colombia, and San Blas before transiting the Panama Canal this February. They took a little time exploring Costa Rica and Mexico before heading off for Hawaii — a 32-day journey — then to San Diego. "Schooling is very difficult when we're underway," Thierry reported, "so we try to not do many crossings."

As it is in every family with teens, getting the kids to do schoolwork takes dedication and discipline. "Every morning is school-time," Thierry said, kindly overlooking the fact that we were providing quite a distraction for the kids, now 14 and 11, respectively. "Dulce teaches languages and arts, and I teach sciences."

*Kir-Tidou* spent a few months in San Diego, where the family made many friends, before heading up the coast to the Bay. They planned to stick around the area for a month before heading back to San Diego — if the boat doesn't sell by then. "The kids want to go to a real school and meet other kids," said Thierry. They plan to sell the boat (see *Kir-Tidou's* ad in this month's *Classy Classifieds*), then return to Portugal, Dulce's home country and where they have a house. "When Eva goes to university," said Thierry, "we'll buy another boat and continue travelling."

internally," Cindi said. Kirk was packed up into an ambulance for the hour-long drive to a bigger hospital. "They had to give him four units of blood on the trip and four more in the operating room."

Once in the OR, surgeons repaired four tears in blood vessels between the esophagus and the stomach — all caused by violent vomiting. "The doctor said that if we'd continued on to Coos Bay, we'd have arrived with a dead crewmember," recalled Adam with a shudder. *Bravo* headed for the Bay with no more drama to report.

As for their future cruising plans aboard *Bravo*, which they've owned for eight years, Adam and Cindi are open. Cindi, a hospital pharmacy director, doesn't retire until November — she took a month off to make the trip south — so she and Adam, a retired architect, will wait until December to head south of the border. "We want to see Central America, but otherwise have no hard and fast plans."

The one thing they are firm on is their philosophy on life. "I was diagnosed with breast cancer in June," Cindi said. "I had radiation therapy and I'm fine, but it, coupled with Kirk's situation, really cemented the fact that, no matter what you want to do, you should just get out and do it." Amen to that!



# PASSIN' THROUGH



**Mia II**, 43-ft Laurent Giles-designed woodie, Victoria, B.C. — Paul Smulders and Julie Newton aren't strangers to the Bay. Not only did Paul, a Dutch boatbuilder, spend time here 30 years ago aboard the homebuilt 53-footer *Puppeteer*, but he and Julie passed through five years ago on their first southbound trip together aboard *Mia II*.

"We spent a year and a half fixing stuff the previous owner Bob had done — we call them 'Bob Jobs' — and finally left in the fall of '05," said Julie. But Julie had been working on more than the boat in that time. As a custom shirtmaker and alternative transportation activist, Julie's life had been, until she met Paul, landbound. "I knew if I wanted to go on this trip, I had to reinvent myself."

Excited about the future, Julie became even more frugal than she already was. "I would walk rather than spend \$2.25 on the bus because I knew how far that would go

## The Simple Choice For Fresh Water

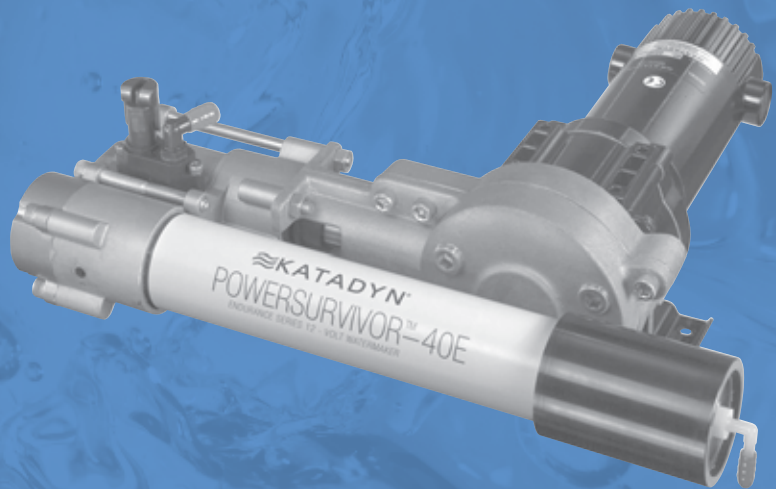

Katadyn PowerSurvivor Watermakers are small, reliable and easy to maintain. That's why they are the best selling watermakers for cruising sailors.

Making your own fresh drinking water is a great addition for the independent lifestyle. Katadyn watermakers are simple in design, moderately priced and have proven reliability.

For about \$3,400, it's a great way to improve life onboard.

800.755.6701 • [www.katadyn.com](http://www.katadyn.com)

**KATADYN**<sup>®</sup>  
MAKING WATER DRINKING WATER

in Mexico," she noted. The couple credits their frugality with stretching out their cruising time.

Once they left Sausalito in '05, Paul and Julie took their time heading south to Baja, then on down to Acapulco. "It got too hot, so we moved on."

They were able to get a 21-day permit to visit the Galapagos but, shortly before their permit expired, they were hit by a service vessel. "Most people only get to stay for three weeks," laughed Julie, "but we got to stay for two months!" Of course, they spent four months in Ecuador effecting repairs, but that also served to prepare the boat for the rough trip down the coast of South America to the channels of southern Chile.

"We spent 21 hard-core days beating against the current down the coast of Peru," said Julie, noting that they didn't stop because they'd been told Peru wasn't cruiser friendly. "Since then, we've heard otherwise."

Once they reached Chile, the pair say they were treated like royalty. "But we bucked, *bucked* down that coast,"

recalled Julie. "We could only move on days with no wind, otherwise we had to stay put." In all, the trip down to Puerto Montt at the northern end of the Patagonia Canals took 54 days.

Exploring the canals took another month or two — "There is nothing, absolutely *nothing* there in the way of civilization," said Julie — before arriving in Ushuaia. They spent the winter moving between Ushuaia and Puerto Williams,

*"I'll take the title of 'cruiser' — it's better than staying ashore!"*

with Julie even getting a job teaching English.

During their stay, Julie grew concerned that she had breast cancer. "A walleyed gynecologist in Ushuaia — I didn't know which eye was the good one — said I was ok, but I knew it wasn't right." So once spring arrived, *Mia* found herself heading back north to Puerto Montt, dodging bergie bits as she went.

Paul and Julie then headed to the Marquesas, where they spent a couple months cruising before reaching to Hawaii. They spent another couple months exploring the islands, then made the three-week leap to Canada in May '08.

Back in the land of socialized medicine, Julie found out that she did indeed have cancer. She ultimately underwent a mastectomy, radiation, and chemotherapy. "The whole nine yards," she said. "But I talk about it in the past tense now. It was two years of hell, but getting here yesterday was wonderful — it's still hitting me that we're going cruising again."

Paul and Julie planned to stay on the Bay for a couple of weeks before heading south. "We'll be out for five years, at least," said Paul. "Maybe indefinitely." They plan to cruise the South Pacific, New Zealand, Tasmania, and all the spots they missed their first time out.

"Someone at Galilee Harbor called me a 'cruiser', not meaning it in a bad way," noted Julie. "I'll take the title of 'cruiser' — it's better than staying ashore!"

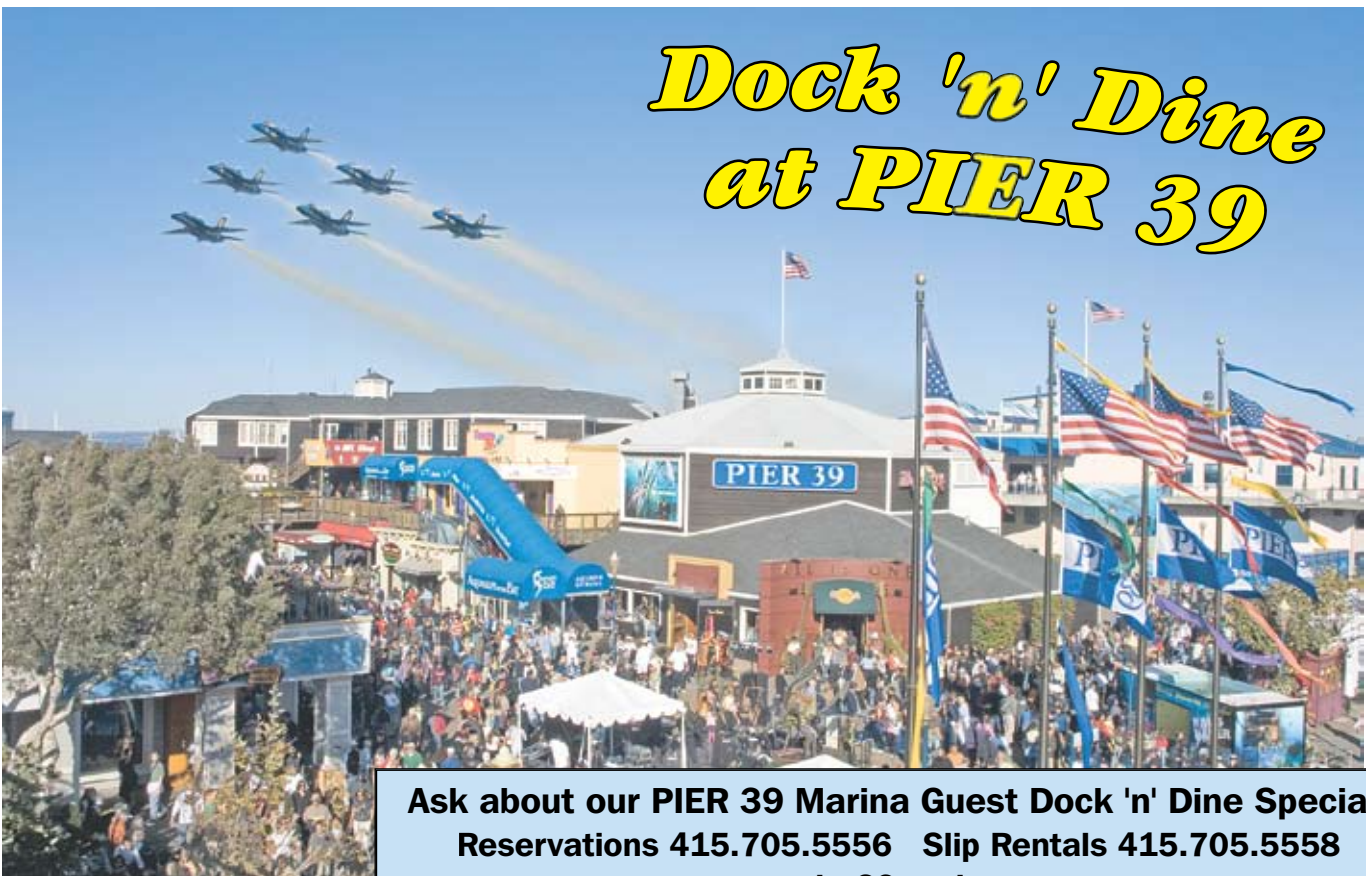

**Dock 'n' Dine  
at PIER 39**

**Ask about our PIER 39 Marina Guest Dock 'n' Dine Special!**  
**Reservations 415.705.5556 Slip Rentals 415.705.5558**  
**[www.pier39marina.com](http://www.pier39marina.com)**

# TOP TEN TIPS

Given the fact that the global and U.S. economies have been struggling, we asked noted sailing skinflint David Wegman for some tips on circumnavigating the economic downturn by cruising

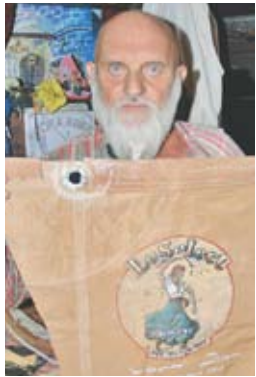

**The Ultimate Recycler with his art on a bit of his old mainsail.**

on the ultra cheap. Wegman built his 32-ft Block Island schooner *Afrigan Queen* 30 years ago, did an eight-year circumnavigation, and for the last 12 years has been cruising the Caribbean six months a year.

Wegman is the perfect sailor for the task, because he has always carried sailing thrift to the extreme — even during boom times and even while spending months at a time at St. Barth, potentially the most expensive island in the Caribbean. “Yeah, I’m cheap,” he thunders proudly. “I’m even cheaper than Jim Green, and he and his wife Anna started the second of his three circumnavigations aboard his wooden 10 Meter *Tango II* with just \$150.”

Despite being ultra thrifty, Wegman has countless friends in some of the nicest places on earth between Bequia and Maine, picks up new ones like dogs do fleas, hosts free art and music schools wherever he goes to encourage people of all ages to get in touch with their creative side, and has more fun in life than just about anyone.

The concept of this article was for Wegman to give us his Top Ten Tips For Circumnavigating the Recession on the Cheap, but as we were dealing not just with a professional artist, but with an artist who sees humor in just about everything, it came as no surprise that he quickly ran off the canvas. Nonetheless, here are his tips:

**Lord only knows how long someone else used this chain before Wegman got it, but it's still holding strong.**



## 1) Learn to Live Simply

“That means doing without all kinds of gadgets and stuff that cost money but always need repairing. I laugh when people ask me if I have a watermaker. My awning is my watermaker. I have a 30-gallon water tank and 10 gallons in jerry jugs, and that’s always been plenty for me — even during my circumnavigation. I don’t have a shower because they’re a big waste of space and water. When it’s time to wash up, I put my copper tea kettle on the stove for exactly four minutes, and take an outdoor shower. The water is warm, and I know the air will be warm because I only sail in the tropics.

“And what’s with these people who own boats that have heads with toilets, and galleys with sinks? I’ve got two buckets. The yellow one is for washing dishes on deck, the black one is to shit in — so you don’t want to mix them up. These ultra simple head and shower systems have worked just fine for me for 40 years, and I’ve never once had to clear a clogged toilet. In fact, most of the time I don’t even use the black bucket to take a dump in, as I’ve found a comfortable place to squat up by the windlass.

“While sailors probably waste the most money on useless electronic gadgets, a few of them are actually worthwhile. I’ve got no problem with a \$100 handheld GPS. In fact, I had one for 15 years until I couldn’t read the screen anymore. I’ll probably even get another one some day. And perhaps the best electronic thing I ever bought was my Icom 700 SSB radio. For during my circumnavigation, I could call home from places like Tonga via phone patches. The SSB is old now, but still works great.

“The electronic things that I think are the biggest wastes of money are knotmeters, wind instruments, depth-sounders and all the electronic crap like that. Who needs wind instruments when you can hang some yarn from the rigging? Who needs a depthsounder in the tropics where the water is clear? Sure, it might make sense to have one up north where the water is murky and it gets foggy, but who wants to sail up there? I used to have a VHF radio, but then the antenna got so corroded it fell off the mast and into the water. I didn’t think the VHF was any great loss. Somebody later gave me a handheld VHF, but I haven’t found

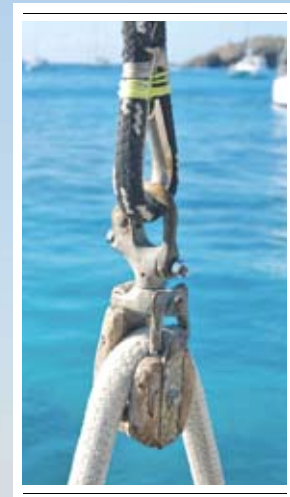

much use for it.

“And no, I don’t have an EPIRB. But I do have a life-ring with the letters ‘TFB’ stenciled on it. They stand for ‘Too Fucking Bad’ — which is perfect for anybody who falls overboard. You just can’t let yourself do that. And I don’t believe there’s any such thing as a ‘safety harness’. In the case of my schooner, she’s got so much rigging you’d have to be pretty damn clumsy to fall overboard. But I’ll tell you something that did scare me. I recently delivered a big Hunter from Key West to St. Martin, and the roller furling came undone in 40 knots of wind. I had to go forward, and I couldn’t find anything to hold onto up there. I was scared.

“When it comes to safety, my dinghy is my liferaft. If *Afrigan Queen* sinks, I’ll grab all the water I can and hop into the dinghy I built. Naturally, I’d also take my passport, whatever money I have — and probably my sewing machine. But water is the big thing, because I could easily rig some kind of sail on my dinghy and get somewhere pretty quickly, particularly in the Caribbean where the wind always blows.”

# FOR CIRCUMNAVIGATING THE RECESSION



*Spread; In Wegman's world view, we're all part of one big family. So when he does 'Sundays at Columbie' with his schooner, everyone is invited. Insets left; The 'Queen' doesn't have the latest blocks or winches. Inset right; The 'Queen' as a children's playground.*

## 2) Never Pass a Dumpster Without Jumping In — Or At Least Taking a Look

"All the rigging on my boat came from boatyard dumpsters. Normally you wouldn't keep the same standing rigging for 30 years, as I have done, but all my stuff is oversized, so I figure it's still good.

"Almost all of my original sails came from dumpsters, too. The only sail I added prior to my '89-'98 circumnavigation was a headsail I bought for \$1,000 from sailmaker Manfred Dietrich in St. Thomas. I did a lot of handwork on that sail to keep the cost down. But in the end, the sail didn't really cost me anything. In fact, I made money on it. For after my circumnavigation, I cut the sail into 70 panels of about 16 inches by 24 inches each. I made sure each piece had a grommet or bit of bolt rope to give it that nautical feel, then I silk-screened a copy of one of my paintings on them, and topped it off by dating and signing them. I then sold them for 25 euro each — which back then was about \$35 U.S.

— or a total of about \$2,000. Just this year I cut up my mainsail from '86. I'll get another 70 panels, or about another \$2,000 out of that. 'Optimum recycling' is what I call it when you get complete use out of something, then sell what's left for 100% more than you paid for it.

"I don't pass many flea markets either, as you can find good deals at them also. But nothing beats boatyard dumpsters. A long time ago, I found a \$3,000 cello in a dumpster on St. John in the U.S. Virgins. It was too big for my schooner, so I cut it down to a stand-up bass. I take my bass to all the jams — although I sometimes bring my guitars and harmonicas, too. Hey, someday you got to see the guitar of mine that Keith Richards autographed on New Year's Eve of '00 at Foxy's on Jost van Dyke. Normally you autograph the face of a guitar with something soft like a felt pen, but we'd been drinking quite a

bit and all we had was a ballpoint pen. Keith wasn't shy about digging into the face of the guitar with that pen either. But we had a great time playing together for hours that night.



"I don't ever buy anchor chain either, because I can find that for free. When most sailors see their chain getting a little rusty, they freak out and buy new stuff, leaving the old chain lying around in the boatyard. As long as the links are fat, I'll use the chain. Whenever my current chain gets close to needing to be replaced, I just keep my eye out on the docks and in the yards. It's never hard to find free chain. Wait a minute, I now recall once paying \$100 for some anchor chain — but it was \$600 worth of chain."

## 3) Engines and Transmissions Don't Have to Be Expensive

"Thirty years ago, my boat started out with a used two-cylinder Yanmar diesel that I paid \$700 for. After using it for 30 years, I'm now selling it for \$800. You see, I upgraded a few years ago when I heard about a guy in the British Virgins who had a 3-cylinder Yanmar diesel from a genset. The cheapest new Yanmar diesel is \$5,000, and that's for a tiny one. But I got this great used one for only \$1,500. I just threw it on deck and left it at Manfred's sail loft until I hauled my boat the following season. Meanwhile, while checking out a junk pile at a boatyard in St. Thomas, I found a transmission for the engine. The yard owner told me it was mine for the taking. It took a little work to adapt the transmission to the engine and to get everything to fit,

*Wegman, seen here with Shaliz Koleni of Marin and the skull and femur of Kenny, a long dead sailor, never gives up on old friends.*



# TOP TEN TIPS

but the combination has worked really well.

"Not that I waste much money on diesel. After all, I've got a sailboat, so I sail. Besides, what's the rush? And the few times I do use the diesel, I run the engine at very low speed, burning hardly any fuel at all. I cruise six months a year, during which time I burn a total of about eight gallons."



*Wegman's Aries vane is a loose as they come — and thus works great.*

#### **4) Don't Spend More Than About \$150 On Your Dinghy/Outboard.**

"I designed my own rowing dinghy in a couple of hours by cutting the cardboard cover of a notebook into 12 pieces and taping them together to create a 12-inch model of what I wanted. Then I lofted it onto graph paper. The only materials you need to build a dinghy like mine are three sheets of quarter-inch ply, sawdust, epoxy, and some drywall screws. It only takes three days to build a dinghy, and that's not even working all day. I had my first one for 15 years, and I've had my current one for four years. And anybody who knows me knows that I don't baby my dinghies, so they are super durable.

"I don't want to brag, but my dinghies are the best you'll ever find. In fact, if you build one like mine, you won't even want an outboard. I had a British Seagull outboard once, but it wasn't worth the trouble. And I'm speaking as a guy who used to build dragsters from scratch behind the back of my dad's machine shop. No, I always row.

"It takes me 15 minutes to row a mile, and it doesn't cost me a cent. The nicest part is that I don't have to listen to a

*Wegman's rowing dinghy may not be finished to yacht standards, but it's cheap, functional and durable.*



noisy engine, smell a stinky engine, or go to the gym to keep from going into cardiac arrest — like people with outboard-powered dinghies. They'll be going in for heart surgery while I'm rowing back to my boat, that's for sure. You know how I'll know when my sailing days are over? When I can't row between my boat and the shore. But I'm only 65, so I've still got a lot of sailing left in me."

#### **5) Know How to Fix Stuff**

"As I mentioned, I grew up around a machine shop in the Midwest and built a dragster from scratch, so I became familiar with and confident with all kinds of tools and techniques. They have all served me well on boats. Family farmers have always had to know how to fix just about everything they own themselves, which is why they always have an easier time cruising than do retired doctors, lawyers and accountants. Let me give you some examples.

"I paid \$400 for an Aries windvane. It's a really great piece of equipment even though I've had to rebuild it from time to time. The Aries vanes are famous for the bushings freezing up, but that's because the Teflon bushings are too tight. The bearings have to be loose! So a lot of folks who think their Aries are no good or are broken just need to take the shaft out and enlarge those Teflon bushings. My Aries is 25 years old and works like it's brand new because I keep the bushings as loose as an old pair of shoes.

"I've got three anchors: a 60-lb CQR, which is the big mama, a little Bruce lunch hook, and a big Danforth. I didn't buy any of them. The Bruce was bent, but all I had to do was put it in a vise and straighten the shank. Another anchor had been thrown away because of a loose fitting. I welded it up in a few minutes, and it was as good as new. I didn't have to fix the third one, as somebody just gave it to me. You'd be surprised what other sailors will give you when they're replacing stuff — and so many sailors replace stuff for no good reason.



"One of my best fix-its was in Thailand. When I got there in '96, my wood masts were so rotten that I sawed them off at deck level and let them fall into the water. I wasn't sure how I was going to replace them, but then somebody told me there was a Proctor aluminum mast in a ditch next to Dim's Dine and Dance, which was Tristan Jones' old hangout at Ao Chalong Bay, Phuket. The only problem was that the mast was curved like a banana. But I dragged the thing up to a nearby expansion bridge, tied each end of the mast to the bridge, and started to work on the bend with a Spanish windlass. After two days, the mast still wasn't straight, but it was reasonably close. So I put it in my dinghy and floated it out to *Afrigan Queen*. The only problem was that it was still five feet too short for the mainsail. I solved that problem by carving a piece of wood the size of the interior of the mast and using it as the step. That was in '95, so it's been working fine for 15 years. And that included lots of 40- to 50-knot winds off the coast of South Africa."

#### **6) Always Anchor Out — If You Can't Get A Free Berth.**

"For example, when you pull up to the yacht club at Richard's Bay in South



# FOR CIRCUMNAVIGATING THE RECESSION



*Wegman's Sunday at Columbie aboard 'Afrigan Queen' has a mild resemblance to neo-impressionist Georges Seurat's 'A Sunday afternoon on the Island of La Grande Jatte', wouldn't you agree?*

Africa, they give you a free bottle of champagne and a free berth for a month. That's the way it should be everywhere! While there, I met a guy who needed his two Wharram charter cats painted to look 'native'. So I painted African symbols on them for \$1,000. That was a good thing, because I'd arrived at Richard's Bay with zero money. The painting job paid for my ticket back to Maine for the summer. But something like that always works out.

"And if you have to leave your boat while you return home for the summer, don't pay extravagant slip fees. While in Borneo, for example, I heard about an old Muslim guy with a dock at Lumatt who was supposed to be reliable. So I met him, and he said he'd stay on my boat for \$1 a day. When I got back six months later, my boat was just fine. By the way, after leaving the boat with him, I took the train up to Chang Rai and Chang Mai in northern Thailand, where I loaded up on inexpensive sarongs that I took back to Maine that summer and sold for a healthy profit.

"During my circumnavigation, I left my boat for long periods in Costa

Rica, Tahiti, New Zealand, Borneo, and South Africa — and I never had to pay more than one or two dollars a day. I know this was a while back, but if you're patient and ask around, you can find great deals. The only problem I had leaving my boat anywhere was in Costa Rica. When I returned, I shook out a sail bag and a bushmaster snake slithered out of it and chased me down the bowsprit.

"When I go

to the States for the summer these days, I leave my boat on a mooring at Coral Bay, St. John, U.S. Virgins. I've got a lot of friends there, so they look after her a bit. But if there's a hurricane and she gets destroyed, well, her time will have simply come. I'm not going to worry about it."

## **7) Keep Your Haul-Outs Cheap By Doing Your Own Work and By Working Quickly**

"Maintenance on my boat, which I cruise in the Caribbean six months a year, costs me \$500 a year. I haul every two years and spend \$1,000. Before I haul out, I go to Sea Chest in St. Thomas and buy a gallon of Motar epoxy topsides paint for \$35. I paint the topsides of my boat every two years whether she needs it or not. Now a lot of folks will pay \$300 a gallon for bottom paint. Not me. I look up the rasta guys who work in the boatyards, because when they paint

a boat bottom, they always have a little left over, and they dump it into a five-gallon drum. I give them \$100 for that five gallons of mongrel bottom paint, and slap it on. During the haulout, I also put in a new cutlass bearing, which is about \$70, and maybe \$30 in zincs.

"But to be thrifty, you have to do your own work, and you have to work hard, because the cost of lay days will kill you. I mean it. There's no dicking around during a haul-out. You work sun-up to sundown. I do my haulouts in four days, and you shouldn't take any longer."

## **8) Don't Forget The Sewing Machine**

"Way back when, I bought a hand-crank Singer zig-zag sewing machine on a lark for \$20. There wasn't much foot tension, so it wasn't good for much more than dresses. So I put copper tubing over the shaft and slide to beef up the tension so I could use it on sails, awnings, dodgers, side curtains, cushions and I don't know what else. It's now strong enough to sew through four or five layers of sail material, but you need an 18-gauge needle and polyester thread. The 12- and 14-gauge needles and cotton thread are for ladies' dresses.

"You probably won't believe this, but that sewing machine has come in so handy that in 25 years I've never gotten around to putting it back in the box. In fact, as I said before, if I ever had to abandon ship, I'd get into my dinghy with water, my passport and money — and

*Looking a lot like Mr. Natural, Wegman rides to his own colorful tune, both as a self-deprecating circumnavigator and an artist.*



*"I have no insurance!" Wegman shouts each time someone dives off the spreaders.*



# TOP TEN TIPS

that sewing machine!

"Another valuable item is my folding bike. I found mine in Key West and mailed it to my boat in St. John for \$40. It's really nice having a bike when you need to go to the laundromat, store, or just to explore. You just don't want to ride up hills."

## 9) Watch Where You Spend Your Money So That You Don't Waste It

"When I went around, I did it on about \$10,000 a year. Of that, \$2,000 was for food, \$3,000 was for the boat, and the remaining \$5,000 was for booze. Just think how little I could have spent if I didn't drink. But I do. If someone has \$1,000 a month, they can cruise and drink at happy hour every day of the week at all the places I've ever been.

"It's easy to eat inexpensively by just eating simple food and participating in lots of potlucks. If it's just me on the boat, I'll usually eat ashore at some inexpensive place. But for long passages, I'll stock up my schooner with rice, beans, tinned butter from New Zealand, and long-lasting fresh stuff like pumpkin

squash.

"During passages, I make a lot of bread on the stove-top. All you need is flour, molasses, oats, corn meal and whatever else might taste good in it. For example, a lot of times I'll throw chopped up onions, garlic, sun dried tomatoes or olives in my bread. I always like to try something new. Anyway, I got my bread down perfect. I usually use 1/3 whole wheat flour and 2/3 white. I cook it on

*"Just think how little I could have spent if I didn't drink. But I do."*

real low heat for an hour in one of those real cheap aluminum pots you get in Asia. After it cooks to a golden brown, you flip it over for half an hour. It's the best bread in the world — and a big staple in my passage-making diet.

"Fishing keeps the food budget down, too. I only fish when I'm on a passage, but I catch some big fish. I use the best — a Cuban hand reel, 200 feet of 500-lb test line, some wire leader, and a yellow feather on a chrome sinker with red eyes and two stainless hooks. You let out 150 feet of line, using a bike inner tube as a shock absorber with 15-ft of slack in the monofilament. When a fish hits, it stretches the inner tube, comes to an abrupt halt, and sets the hook. I've gotten some 100-pound tuna that way. No, I don't use a gaff. I just yank the fish over the low rail. Sure, about 20% get away or are taken by sharks, but I like the simplicity of my method.

"I also brew beer on my boat in five-gallon jugs. It takes 14 days. You bottle it in four days, and 10 days later you drink it from plastic Coke bottles. It's important to siphon it out of the five-gallon container to the plastic Coke bottles so you don't get any scum. It tastes delicious — even though I drink it warm because I don't have refrigeration."

## Spud Point Marina

Just 50 miles from the Golden Gate

Want to get away from the traffic, noise and pollution in the Bay Area? Bodega Bay is the place for you (and your boat). Spud Point Marina has berths up to 80' @ \$8 per foot/month...

*Enjoy the Fun, Sun and Salmon in Bodega Bay*

1818 Westshore Road, Bodega Bay 94923 (707) 875-3535  
spudpoint@sonoma-county.org spudpointmarina.org

# FOR CIRCUMNAVIGATING THE RECESSION

## 10) Spend Most Of Your Time In the Less Expensive Places

"Polynesia is very expensive. The Philippines are very inexpensive — and they are just as beautiful. Dinner is a buck or two, and a beer is a buck."

## 11) The Other Side Of Thrift Is Making Money

"If you're doing a circumnavigation, there are always ways to make money. For example, I worked as a welder for two months on a barge in New Zealand. That was enough for my ticket back to Maine for the summer. During my circumnavigation, I would always sail for six or seven months, then come back to the States for the summers. I'd always bring exotic stuff back to sell.

"While doing my trip, I sold paintings and did other artwork. For example, while in Borneo I was hired to create posters discouraging the locals from killing fish with bombs and fertilizer. One was even presented to the President of Malaysia. I also wrote a book about Squeaky and Morris, two cockroaches who got thrown



*Wegman admits that this bowsprit turnbuckle looks a little funky, but he says it's still plenty strong.*

off a cruise ship in a bag of garbage and drifted ashore in Malaysia. It didn't make the *New York Times* Best Seller List, but I made some money.

"And remember, a few dollars in art supplies can bring big returns. I did a lot of paintings in pastels because they were easy to carry and work with. I would get \$700-\$800 dollars for each painting. And I don't want to hear any of that 'I'm not an artist' nonsense. I teach art for free just about everywhere I go. It's not hard. Some people mistakenly feel you need all kinds of fancy supplies and stuff. Baloney. My friend Bruce Hein of the

Seattle-based *Woodwind* does all his paintings using Rust-o-leum paint. They look terrific and he's sold a lot of them."

**L**augh if you want at Wegman's ideas — we often do — but we can assure you that he doesn't just talk, he walks the walk. And having borrowed his self-designed and self-built dinghy, we're going to try to build one with him for ourselves next spring.

For the record, David Wegman has a studio over the famous Le Select Bar in St. Barth; an interest in Tallship Trading, which is a T-shirt silkscreen company in Coral Bay, St. John, U.S. Virgins; a studio in Key West; an RV in an orchard outside Saratoga, New York, where he grows tomatoes; and a commune-like place in Maine he bought with 10 others from the Caribbean many years ago. During this year's Carnival, Wegman came dressed as Aunt Jemima, wearing blackface and a mammy outfit he made using his beloved sewing machine.

— *latitude/rs*

## STAY FOCUSED WITH OUR EYE SAFE NO-STING FORMULA



Z Blok sunscreen's new non-greasy formula will not burn or irritate your eyes. So you can concentrate on winning the race or just enjoying a great day on the water. Z Blok is also fragrance free.

Z Blok is the official sunscreen of the PUMA Ocean Racing Team. Skipper Kenny Read said:

*"The UV protection is excellent. Every member of the team is a true believer. We have put Z Blok to a tough test that few others can. Most importantly, we have experienced no eye stinging or irritation and we use it every day."*

Visit [zbloksun.com](http://zbloksun.com)  
or call 508.995.9511

**OFFICIAL SUNBLOCK OF THE  
PUMA OCEAN RACING TEAM**

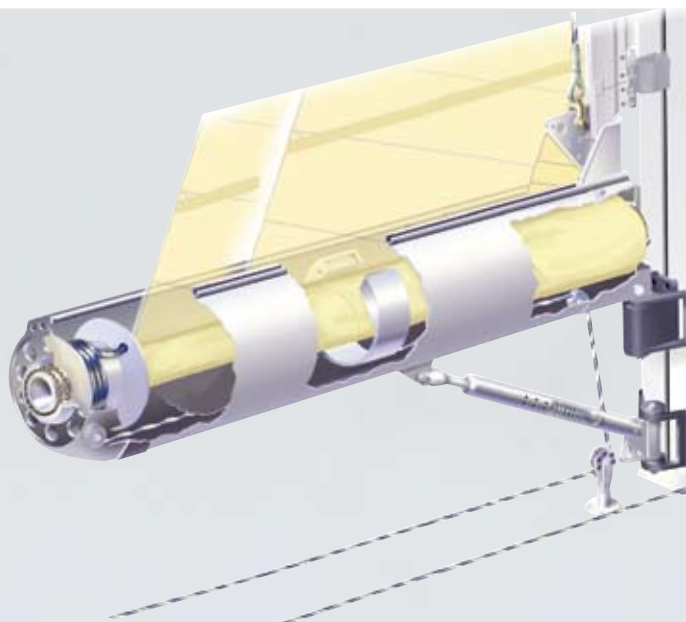

## FURL ON THE FLY.

With Schaefer's innovative boom furling system and patented articulating sail track, you can reef your main on any point of sail - all from the safety of the cockpit. Trouble free reefing and furling - just what you would expect from Schaefer Marine.

**SCHAEFER**  
LEGENDARY STRENGTH

508.995.9511  
SCHAEFERMARINE.COM

# BAJA HA-HA PROFILES, PT II —

When we reached the entry deadline for this year's Baja Ha-Ha cruiser's rally late last month, we were struck by the irony of the fleet totals. Despite the dour recession, last year's total of 193 was an all-time high, and this year's 188 is a close second.

But perhaps those numbers have more to do with pragmatism than irony. The way we figure it, the 2010 fleet members probably belong to one of two groups, the first being comprised of folks who've been working toward the goal of long-term cruising for so long that virtually nothing is going to stop them from realizing their dreams. And we'd guess that the others are sailors who may not have much cash flow, but figure, "What the heck? The boat's paid for and it's a whole lot cheaper to live in Mexico, so let's set a course for *mañanaland*."

As in years past, 2010 Ha-Ha'ers come from a wide range of backgrounds and the boats they sail on are equally diverse. You'll meet a slew of them here, in this second installment of mini-profiles, and the remainder next month.



Mexico awaits Leanne and Jack of 'Red Sky'.

**Red Sky — Moody 54**  
**Jack & Leanne Hembrow**  
**Brisbane, Australia**

*Noteworthy:* This Aussie couple has already done several South Pacific rallies. After the Ha-Ha they plan to eventually transit the Panama Canal and join the ARC Europe Rally in May 2011.

**Content — Perry/Litton 47**  
**William Holmes & Paula Collins**  
**Homer, AK**

*Quote:* What's the most interesting thing about this 1979 Robert Perry-designed cutter? "It's paid for!"

**Windfall — Maple Leaf 42**  
**Sam & Nancy Cockrell, Portland, OR**  
*Noteworthy:* For Sam and Nancy the



Sam and Nancy will 'go around' on 'Windfall'.

Ha-Ha will be the beginning event in their proposed circumnavigation. After cruising Mexico, they'll head to the South Pacific.

**Sudden Stops Necessary —**  
**Beneteau First 38s5**

**Chet Chauhan, San Francisco**

*Quote:* "I hope to be the first British, Kenyan-born sailor of East Indian descent to sign up for the Ha-Ha 2010."

**'O — Davidson 44**

**Robert & Bobbie Kuschel**  
**Redwood City**

*Noteworthy:* This aluminum-hulled, Laurie Davidson-designed, fractional sloop is a former racer that supposedly helped break the IOR rule.



Robert and Bobbie's 'I'O' is Aussie-built.

**Sulaco — Swan 371**

**Glenn Brake, Marina del Rey**

*Quote:* "The last time I went down the Baja and back up was in a Columbia 24 with a 6hp outboard. This trip should be more friendly."

**Symphony — Fuji 32**

**Joel Tuttle, San Francisco**

*Quote:* "Realize your dream of casting off and sailing into the unknown, knowing that in years to come today's dream will be tomorrow's reality."



**Mazu — Outbound 46**

**Mel & Elaine Bryson, Rainier, OR**

*Noteworthy:* The Baja Ha-Ha will be the initial leg of the realization of a long-delayed dream that originated in Lahaina, Maui in '78; namely, to sail to the South Pacific on an open-ended voyage. Let the adventures begin!"

**Double Dharma — Hunter 466**

**Dale & Dena Snearly, San Leandro**

*Quote:* "Shift change! We have retired and are beginning our new life as full-time cruisers exploring the beautiful waters of the world."

**Coppertop — Bayfield 32**

**Paul Moran, Brookings, OR**

*Noteworthy:* After the rally, Paul plans to do a Pacific circuit: the Puddle Jump to French Polynesia, north to Hawaii, then home to the Pacific Northwest.

**Wind Rose — Cabo Rico 40**

**Walter & Patricia Simmons**  
**Los Angeles**

*Quote:* "The *Wind Rose* has taken good care of the Simmons family. She has helped us to weather storms, strengthen family ties, nurture a sense of adventure, and renew our faith. Now she will show

# SAILING TO SUNNIER LATITUDES



Above: The fleet rides a fresh breeze south from Turtle Bay under sunny skies. Spread: Hikers stretch their sea legs during the rest stop at Bahia Santa Maria.

**Island Time — Seawind 1000 cat**  
**Larry & Nancy Robertson**  
**Dana Point**

*Quote:* "I'm hoping this is a good experience for my wife," says Larry, "so she will want to really go cruising when I retire."



This crew is eager for some 'Island Time'.

**Barramundi — Seawind 1000 cat**  
**Steve & Pam Ellsworth**  
**Newport Beach**

*Quote:* How do they describe their attitude toward the Ha-Ha? "The 3 'F's: Friends, fun and frickin' warm weather!"

**Santorini — Mariner 48**  
**Dawn Fleming & Thomas Clifford**  
**Wilmington**

*Quote:* "We saw this boat for sale at a boat show in 2001, then hung the broker's flyer on our refrigerator, dreaming about owning her one day. Five years later, we tracked down the owner and found out he had her listed for sale. We bought her and sailed her to her new home in SoCal. So dream big dreams. They do come true!"

**Seasilk — Hylas 46**  
**Craig Blasingame & Sue Steven**  
**Coronado**

*Quote:* "We've looked forward to doing the Ha-Ha ever since we bought Seasilk as our liveaboard home four years ago."

**Bonnie Lass — Catalina/Morgan 440**  
**Bill & Lorell Alexander, Tiburon**

*Noteworthy:* Bill and Lorell have no plans to return home. Instead they'll "just keep going south."

**Setting Sun — Pearson 323**  
**George Johnstone, San Rafael**

*Quote:* Why did George enter the Ha-

us the world beyond Southern California."

**Sonrisa — Baba 40**  
**Scott Bowen**  
**Green Cover Springs, FL**

*Quote:* "I've waited for this part of my life to start since I was 12 years old. Now, it's all about the journey ahead. I've discovered that it's never too late to



The 'Sonrisa' crew is all smiles.

have a happy childhood. But the second one is up to me, nobody else."

**Rosebud — Cal 36**  
**Greg Rodgers, San Pedro**

*Quote:* "Rosebud is hull #1 of this Cal

36 design; still going strong and looking to stretch her legs."

**Dodger Too — Tartan 37**  
**Leif & Jackie Watson**  
**Edmonton, AB, Canada**

*Quote:* "We built her in '83, spent two years in the Med, crossed the Atlantic, and now have spent a long time on the West Coast. She has looked after us well and we are sure she will continue to do so."

**C'est La Vie — Amel Mango 52**  
**Bob Bohn, Anacortes, WA**

*Quote:* "Going where the weather suits my clothes."

**Otter — Westsail 32**  
**Greg & Joyce Parfitt, Scappoose, OR**

*Quote:* "We have dreamed of this first leg of our trip for so many years. It's so exciting that it's finally becoming a reality instead of a dream."

**La Condessa del Mar**  
**Herreshoff 65 schooner**

*Quote:* "La Condessa is a comfortable, heavy sea cruiser and needs to get over being dock-bound."

LATITUDE / ANDY

# BAJA HA-HA PROFILES, PT II —

Ha? "It is too cold here!"

**Gratitude — Island Packet 485**

**Mike Irwin, Alamitos Bay**

*Quote:* "Any time spent sailing is not deducted from your life expectancy."

**Abagwit — Niagara 35**

**Werner Landry & Allison Sherwood  
San Diego**

*Noteworthy:* The name *Abagwit* is a Micmac Indian word meaning "in the cradle of waves."

**Taverna — Catalina 470**

**Sal & Debbie Vitale, San Francisco**

*Quote:* "We're finally getting underway!"

**Fixin' To — Hylas 44**

**Jim & Sharon MacIntosh  
San Francisco**

*Noteworthy:* In 2002 Jim passed a Catalina 22 that was advertised for sale on a country road in central Oklahoma, and his sailing passion was sparked to life. He named the boat *Sudden Impulse* and took sailing lessons on Oklahoma

lakes. Sharon was coaxed into First Mate training and the dreams began.



*An impulse led Jim and Sharon to 'Fixin' To'.*

**Phambili — Given 45**

**Tommy Lorenzo & Fiona Coleman  
Victoria, BC**

*Noteworthy:* This Ron Given-designed hull was built on Saltspring Island by Bill Moseley, who sailed her to New Zealand

and back with his wife Dominique.

**Seabird — Swan 51**

**Lou & Marge Freeman, Ventura**

*Quote:* "This is our annual 'push the boat' opportunity." *Seabird* has done three previous Ha-Has.

**Intuition — C&C 37XL**

**Ron & Connie Holbrook, Tacoma, WA**

*Noteworthy:* In addition to doing the '05 Ha-Ha, *Intuition* has done three Chicago-Mac races, the Van Isle 360, and numerous Swiftsures.

**Ticket — Beneteau 47.3**

**Rick Niello, Sausalito**

*Noteworthy:* Rick started sailing at age 10 and still loves it.

**Wyspa — Baltic 55 DP**

**Roger Waterman, Del Mar**

*Quote:* "Life is for living!"

**Touchrain — Ericson 38**

**Michael & Jan Wilson, Olympia, WA**

*Noteworthy:* *Touchrain's* previous

**Let Hydrovane sail you home safely.**



▲ Polar circumnavigator Adrian Flanagan.

**YACHTING** MONTHLY October 2006  
100 best bits ever

Latest ARC survey –  
Hydrovane again the  
most popular wind vane.

Totally independent self-steering system and emergency rudder... in place and ready to go.

WWW.HYDROVANE.COM



SURVIVE YOUR DREAM

**info@hydrovane.com PHONE 1.604.925.2660**

*Welcome to Mazatlan...*



*Marina El Cid style!*

A CRUISER'S PARADISE IN THE HEART OF MEXICO'S LUSH TROPICAL COASTLINE AND BEAUTIFUL ISLANDS

*Complete, Modern Amenities, Including  
Marina-Wide High Speed Wireless Internet Connections!*



**www.marinaselcid.com**  
011-52 (669) 916-3468  
marinaelcidmazatlan@elcid.com.mx

*The Cruiser's Home in Mexico*

# SAILING TO SUNNIER LATITUDES



Jan and Michael of 'Touchrain'.

owner bought her with his earnings from acting in *Free Willy*. He had the only speaking part at the car wash scene!

**Bright Angel — Mason 44**  
**Bob & Linda Hargreaves**  
**Olympia, WA**

*Quote:* "We've sold the house, sold the furniture, sold the kids (oh wait, they left on their own) and moved aboard. . . The Ha-Ha will be the first, giant leap into our long-awaited and much-anticipated new cruising life!"

**Hand Full — Islander 34**  
**Tiffin & Neil Rife, Half Moon Bay**

*Noteworthy:* When approaching from astern, you'll know it's *Hand Full* ahead of you, as she bears the handprints of all four crew members on her transom.

**Dragon's Toy — Island Packet 37**  
**Tom Kohrs & Cary Purvis, Freeport**

*Quote:* "Fate has had us crossing each other's path for the last 15 years. We both did the '06 and '08 Ha-Ha's but never met until we signed on to do

Tom and Cary of 'Dragon's Toy'.



a delivery from Panama to Florida early last year. We have been inseparable ever since."

**Moonbeam — Seidelmann 299**  
**Scott Dobias, Long Beach**

*Quote:* "Moonbeam may be small, but she's packed full of treasures."

**Ohana — Beneteau 45f5**  
**Steve Hocking & Marika Edler**  
**Eagle Point, OR**

*Noteworthy:* To Steve and Marika the Ha-Ha is synonymous with romance. They got engaged during the '08 Ha-Ha.

**Serendipity — Gozzard 36**  
**Hugh & Anne Jenings**  
**Port Ludlow, WA**

*Quote:* "Time to quit talking and just do it."

**Kanga — Valiant 40**  
**Jim Hassberger & Jeanne Harvey**  
**Coos Bay, OR**

*Noteworthy:* Jim and Jeanne plan to winter in Mexico, and are strongly con-



Remote Satellite Systems

888.989.8199 • [www.remotesatellite.com](http://www.remotesatellite.com)

**GLOBAL COMMUNICATION BREAKTHROUGH  
JUST IN TIME FOR OFF SHORE CRUISING!**



Isat Phone Pro

- Special equipment priced as low as \$495
- World wide coverage
- Airtime as low as \$19.90 per month and \$0.80 per minute
- We can ship today!



Sailor 150 Fleet Broadband

- Broadband Internet at Sea
- Data and Internet capability
- Voice

# BAJA HA-HA PROFILES, PT II —

sidering doing the 2011 Puddle Jump.

**Rocinante — Beneteau 473**  
**Cooper & Phil Patterson, San Diego**  
*Quote:* "Slow is smooth, smooth is fast!"

**Sound Effect — Dufour 385**  
**Jim & Connie Merritt, Tacoma, WA**  
*Quote:* "After a decade of sailing in Seattle we want to see how good we look in sunglasses!"

**Sterling — Catalina 34**  
**Byron Cleary, Sausalito**  
*Quote:* "If you are first, you are last!"

**Enchantress — Liberty 49**  
**Melinda Morgan & Steve Cross**  
**Port Ludlow, WA**  
*Noteworthy:* This may be the only boat in the Ha-Ha fleet with a hand-carved figurehead.

**Music — Nordic 44**  
**Gail Lapetina & John McCartney**  
**Bellingham, WA**  
*Quote:* "After years of sailing Washington, Canada and California, we're

looking forward to warm balmy breezes and margaritas!"



*Gail and John will make beautiful 'Music'.*

**Tara — Caliber 28**  
**Jonathan Neely & Shannon Walker**  
**San Francisco**  
*Quote:* "If there is clear water, good beer, and great sailing, then count me in!"

**Moonbow — Crowther 38**  
**Richard McCredle, Dana Point**  
*Quote:* "Sail Fast Live Slow."

**JaneO — Privilege 39**  
**Scott & Christine Emmons**  
**Redwood City**  
*Quote:* "We're home-schooling our 17-year-old son. Are there any Algebra II teachers doing the rally?"

**Peregrine Spirit — Ericson 380**  
**Tony & Kathleen Van Houweling**  
**San Diego**  
*Quote:* "Doing the rally as crew in 2002 was wonderful. But doing it on my boat in 2010 is a dream come true!"

**Exit Strategy**  
**Jeanneau Sun Odyssey 46.5**  
**Steve Ginder, Dana Point**  
*Quote:* "Old guys rule!"

**Magda Jean — Valiant 40**  
**Michael & Katharine Bird, San Diego**  
*Quote:* "The rally will be the beginning of our life as rootless cruisers."

**Legacy — C&C 34**  
**Lewis & Willa Keizer, San Francisco**  
*Noteworthy:* Lewis is an independent (heretical) Bishop who plans to offer Sun-

*Welcome to La Paz!*



**IN DOWNTOWN  
LA PAZ**

*Join us for the*  
**BAJA HA-HA BEACH PARTY**  
 Thursday, November 18, 4-7 pm  
 at Papas & Beer Beach Club

All new hardwood docks  
 Dinghy landing with potable water  
 New protective piling & sheetpile breakwaters  
 Wireless Internet · and more!

*Friendly, helpful, fully bilingual staff*

TEL: 011 52 612 122 1646  
 email: [marinalapaz@prodigy.net.mx](mailto:marinalapaz@prodigy.net.mx)  
[www.marinadelapaz.com](http://www.marinadelapaz.com)

Apdo. Postal 290, La Paz, 23000, Baja California Sur, Mexico



OUR ANNUAL  
FALL SALE ENDS OCTOBER 6!  
CALL ONE OF OUR  
PARTICIPATING LOFTS  
BELOW FOR A QUOTE!

Ullman  
Sails

An Investment in Performance

<p><b>Newport Beach</b>                  2710 S. Croddy Way                  Santa Ana, CA                  92704                  Dave Ullman                  Bruce Cooper                  Erik Shampain                  Keith Magnussen                  Scott Poe                  (714) 432-1860</p>	<p><b>Marina del Rey/ King Harbor</b>                  Mike George                  (310) 645-0196</p> <p><b>Ventura</b>                  3639 E. Harbor Blvd.,                  #111                  Ventura, CA 93001                  Gary Swenson                  Deke Klatt                  (805) 644-9579</p> <p><b>Santa Barbara</b>                  Ken Kieding                  (805) 965-4538</p>	<p><b>Santa Cruz</b>                  Brent Ruhne                  Ruhne Racing                  (831) 295-8290 cell</p> <p><b>Arizona</b>                  Bruce Address                  (602) 499-3844</p> <p><b>San Francisco/ Sausalito</b>                  (Racing Sails Only)                  Robin Sodaro                  466 Coloma St.                  Sausalito, CA 94965                  (415) 332-4117</p>
---	---	--

*Visit our website:*  
[www.ullmansailswestcoast.com](http://www.ullmansailswestcoast.com)



# SAILING TO SUNNIER LATITUDES

day communion services to interested cruisers.

**Equinox — Jeanneau Sun Odyssey 40  
Don Whittington & Debbie Roemer  
Santa Cruz**

*Quote:* "We're thrilled that the Baja Ha-Ha will be our first big sailing adventure!"

*Debbie and Don of 'Equinox' are psyched up.*



**Dilligaf — Jeanneau DS49  
William Teasdale, Bellevue, WA**

*Noteworthy:* The word *Dilligaf* was used when things went wrong or went well aboard the submarine *Jallao*, which William served aboard.

**Kamekazi — Columbia 41  
Patrick Scroggin, Anacortes, WA**

*Quote:* "Hand over the booze and the wenches, and nobody will get hurt."

**Black Pearl — Cal 30  
Garrett Jolly, Port San Luis**

*Quote:* "When I bought *Black Pearl* for \$4,000, she was dirty, smelly, and what most people would consider a piece of junk. I did all the work myself to bring her back, and worked on other people's boats to save enough money for the equipment I needed. Now, although she won't win any beauty contests, she is strong, well-equipped, seaworthy, and ready for the Ha-Ha and beyond."

**Tumbleweed — Corsair F-31  
Matt Daniel & Paul Boyd, Seattle, WA**

*Noteworthy:* They plan to trailer

*Tumbleweed* from Cabo to Seattle.

**C'est La Vie — Catalina 470  
Keith & Susan Levy, Richmond**

*Noteworthy:* Keith and Susan did the Ha-Ha 10 years ago and spent most of the last decade cruising Mexico, then to the islands of the South Pacific, New Zealand, Australia, the Marshall Islands and Hawaii.

**Jubilee II — Islander 36  
Barry & Joyce Ivers, Sausalito**

*Noteworthy:* This hull was the last Islander 36 built in Costa Mesa. It was given to the shop foreman as a gift, and he took 10 years to finish her.

**Princess Anna — Mainship 390  
Michael McGuire  
Channel Islands Harbor**

*Quote:* "We missed the '08 rally due to engine trouble, but we're rarin' to go in 2010."

**Bateau Frowe — Jeanneau DS 43  
Susan French & Tom Rowe  
Marina del Rey**

*Noteworthy:* Susan and Tom point out

**Welcome to La Paz**  
**BAJA HA-HA**  
*Beach Party at Papas & Beer*  
**Beach Club**  
**THURSDAY, NOVEMBER 18TH**  
 mexican folk dancing  
 live music by jurassic rock  
 food & drinks from 4-7 pm  
 door prizes and much more  
 free for first fifty  
 2010 baja ha-ha participants  
 everyone welcome  
 www.visitlapaz.org

# BAJA HA-HA PROFILES, PT II

that their boat name is "almost unpronounceable in Spanish."

**La Brisa — Morgan 45**  
**Gene Brown, San Diego**

*Noteworthy:* The previous owner was Michael Crawford of the *Phantom of the Opera* musical. As a result, Gene says he sometimes has an urge to start singing.

**Pacific Destination — Catalina 30**  
**Greg Buur, King Harbor**

*Quote:* "Untie the docklines and let's go."

**Firefly — Catalina 470**  
**Ted Silvas & Brenda Jewell**  
**San Francisco**

*Noteworthy:* Part of Ted and Brenda's preparation for the cruising life was doing bareboat charters out of St. Martin, St. Lucia and Tahiti.

**El Tiburon — Passport 42**  
**John Stanec & Luke Ashcroft**  
**Emery Cove**

*Noteworthy:* This boat is a two-time



*Meet Christine and Howard of 'Notre Reve'.*

Pacific Cup finisher that was featured on the cover of the 2000 Pac Cup program.

**Notre Reve — Island Packet 40**  
**Howard & Christine Ward**  
**Chandler, AZ**

*Quote:* "This is our first rally, and also our attempt to permanently untie from the docks. We hope to continue on after the rally and see where time and tides

will take us."

**Kokomo — Sabre 425**  
**Becky & Denny Flannigan**  
**Tacoma, WA**

*Quote:* "It's a hop, skip and a jump to Cabo. So let's start resess."

**Sea Chaser — Cal 2-27**  
**George Dorius, Coos Bay, OR**

*Noteworthy:* "Start small and dream big," says George. His is the smallest boat in this year's fleet.

**SEAduction — Catalina 42 MkII**  
**Dan Lawler, Salt Lake City, UT**

*Quote:* "When I crewed on my first Ha-Ha, I thought of it as a once-in-a-lifetime experience. But it was so much fun, I thought, 'Why only do it once?' So I bought my own boat, and this is my third time!"

*Time out!* That's enough introductions for one month. But you can meet the rest right here in November.

— *latitude/andy*



## Combine Wind & Solar For Complete Power



### Introducing The All New SB3024i/iL DUO-Option

Finally a charge controller that can serve as both a solar charging unit and wind/hydro diversion controller at the same time.

Blue Sky Energy, Inc. manufactures a wide range of solar charge controllers. Visit our website for more information.

- Shown with optional digital display
- DUO-Option supports 20 amp diversion with software upgrade
- 40 amp diversion upgrade available with high current adapter module
- Diverts excess solar power to a useful purpose

800-493-7877 or 760-597-1642  
2598 Fortune Way, Suite K, Vista, CA 92081 USA

E-mail: [sales@blueskyenergyinc.com](mailto:sales@blueskyenergyinc.com)  
Web: [blueskyenergyinc.com](http://blueskyenergyinc.com)

Blue Sky Energy Inc. gets rave reviews in *Practical Sailor* read the article at [blueskyenergyinc.com](http://blueskyenergyinc.com)

QUALITY.....RELIABILITY.....BLUE SKY ENERGY, CHANGING THE WAY SOLAR IS USED EVERYDAY

# BAJA HA-HA XVII

**A RECORD  
195 BOATS  
HAVE SIGNED  
UP!**

**BROUGHT TO YOU BY  
THESE OFFICIAL SPONSORS**

Turn the page for more →

**Yachtfinders/Windseakers**  
in the heart of  
San Diego's boating community  
Specialists in cruising sailboat brokerage for 28 years  
info@yachtfinders.biz • www.yachtfinders.biz  
**(619) 224-2349 • (866) 341-6189** toll-free  
Fax (619) 224-4692

**WWW.BAJA-HAHA.COM**

The Rally Committee encourages you to patronize the advertisers who make this event possible – and take advantage of their Baja Ha-Ha Specials!

**OPEQUIMAR**  
MARINE CENTER CENTRO MARINO

A Full Service Boat Yard in Puerto Vallarta  
88 ton Travelift • Parts • Service • Repairs  
011-52 (322) 221-1800 [www.opequimar.com](http://www.opequimar.com)  
info@opequimar.com

Your Yacht Club  
South of the  
Border



Home  
of the  
Banderas Bay  
Regatta

*Vallarta Yacht Club*

<http://vallartayachtclub.org>  
<http://banderasbayregatta.com>

Everything you need from a full service yacht club.

## GIVE THEM A SEND-OFF

As you may have heard, this year's entry total of 195 boats tops last year's all-time record.

If you'd like to help send this year's fleet on its way, be aware that fleet members will parade past the western tip of Shelter Island at 10 a.m., Monday, October 25, on their way out to the 11 a.m. start. A fireboat will salute them with a shower of spray, and a variety of TV and print reporters will be on hand to capture the excitement.

If you're not familiar with the event, let us explain that the Ha-Ha is a 750-mile cruisers' rally from San Diego to Cabo San Lucas, with stops along the way at Turtle Bay and Bahia Santa Maria.

You'll find frequent updates on this year's event, in addition to all sorts of other hot sailing topics at Latitude's 3-times-weekly news portal, 'Lectronic Latitude' (found at [www.latitude38.com](http://www.latitude38.com).)

Summer  
is safe at  
Paradise



Enjoy  
your stay  
with us!

**Paradise Village**  
BEACH RESORT & SPA

011-52-322-22-66728 • [www.paradisevillage.com](http://www.paradisevillage.com)  
marina@paradisevillagegroup.com

**Nautical Books, Software, Charts  
and more!**



**WAYPOINT**

621 - 4th St., Oakland, CA

[www.waypoints.com](http://www.waypoints.com) • (510) 769-1547

**RIGGING  
ONLY**

Standing and running rigging, lifelines, furlers, winches, headsail poles, main slider systems, windlasses, travelers, wire terminals, blocks and more...  
Expert advice for selection and installation.

Our 26th Year!  
[www.riggingonly.com](http://www.riggingonly.com)  
(508) 992-0434 • [sail@riggingonly.com](mailto:sail@riggingonly.com)

**ICOM**

Award-winning Marine Communications Equipment

Handhelds • Mounted VHF • SSB • AIS

Visit one of our many West Coast dealers

[www.icomamerica.com/marine](http://www.icomamerica.com/marine)

**MONITOR**  
INFORMATION  
**auto-helm**  
WINDSHIELD

**SOS** Emergency  
Rudder  
**Saye's Rig**

**SCANMAR** Factory  
Direct  
INTERNATIONAL

432 South 1st Street • Pt. Richmond, CA 94804  
Toll Free: (888) 946-3826 • Tel: (510) 215-2010  
email: [scanmar@selfsteer.com](mailto:scanmar@selfsteer.com) • [www.selfsteer.com](http://www.selfsteer.com)

**West Marine**

Call

**1-800-BOATING**  
(1-800-262-8464)

for a catalog or the store nearest you.



Est. 1973

**Almar Marinas**

Everywhere you'd like to be  
[almar.com](http://almar.com)

# BAJA HA-HA XVII



## spinlock



The experts in rope handling  
and personal safety.

[www.spinlockusa.com](http://www.spinlockusa.com)



## HITCHIN' A RIDE SOUTH

Last month's Mexico-Only Crew List Party and Baja Ha-Ha Reunion on at the Encinal YC served its purpose by linking dozens of potential crew members with skippers in need of additional watch-standers.

If you missed that shindig and would really like to spend some quality time south of the border, you might still be able to find a ride by visiting our online Crew List at [www.latitude38.com](http://www.latitude38.com). It's constantly updated.

## IS THE PACIFIC PUDDLE JUMP IN YOUR FUTURE?

For many cruisers, the next logical step after cruising Mexican waters for a season or more is to hang a right and head west into the Pacific.

We call that annual springtime migration the **Pacific Puddle Jump**, and report on it heavily in the pages of *Latitude 38*. Making that 3,000-mile passage is one of the most thrilling accomplishments in the realm of sailing. Learn more online at [www.pacificpuddlejump.com](http://www.pacificpuddlejump.com).

## VENTURA HARBOR BOATYARD

Full & Self Service Facility

(805) 654-1433

Two Travelifts • Haul Outs to 160 tons

[www.vhby.com](http://www.vhby.com)

Shoreside Work Slips • Emergency Repairs



Not just a marina – a cruiser's community  
Your best destination across the Sea...

[www.marina-mazatlan.com](http://www.marina-mazatlan.com)

011-52 (669) 669-2936 & 2937

[elizarraga@marinamazatlan.com](mailto:elizarraga@marinamazatlan.com)



Survive Your Dream

**ECHO Tec Watermakers**

604-925-2660

[www.hydrovane.com](http://www.hydrovane.com)



[www.downwindmarine.com](http://www.downwindmarine.com)

2804 Cañon St., San Diego

(619) 224-2733 • (800) 269-0241



[www.sandiegomarine.com](http://www.sandiegomarine.com)

2636 Shelter Island Dr., San Diego

(619) 223-7159 • (800) 336-7369

Mexico 001-500-336-7369



[www.sailingsupply.com](http://www.sailingsupply.com)

2822 Cañon Street, San Diego

(619) 225-9411 • (800) 532-3831

0D36887

Serving Boaters  
Since 1959

## Cruise with Confidence

See Our Half-Page Ad In This Issue

(800) 992-4443

[www.marinersinsurance.com](http://www.marinersinsurance.com)

**MARINERS**  
GENERAL INSURANCE GROUP

Newport Beach, CA • San Diego, CA  
Burlingame, CA • Seattle, WA  
Bradenton, FL • Puerto Vallarta, MX



Let Marina El Cid  
Welcome You to Mexico

A Cruiser's Paradise!

[www.elcid.com](http://www.elcid.com)

[marinaelcidmazatlan@elcid.com.mx](mailto:marinaelcidmazatlan@elcid.com.mx)

011-52 (669) 916-3468

## ¿ MEXICO BOUND ?

GERRY

SEA OF CORTEZ CHARTS

Accurate Navigation Charts & Guides

ELECTRONIC and PAPER

[www.GerryCruise.com](http://www.GerryCruise.com)

## Best Marina in Banderas Bay



MARINA RIVIERA NAYARIT  
BY LA CRUISE

[www.marinarivieranayarit.com](http://www.marinarivieranayarit.com)

(52)3221350798

## The Ultimate Boat Organization Software

Perfect for the Ha-Ha and all offshore cruising:

- Digitally organize all your boat's documents & specifications
- Store manuals, diagrams, pictures, renewals & registrations
- Keep track of maintenance items required & completed
- Save for quick access all your favorite service providers



[www.BoatServiceLog.com](http://www.BoatServiceLog.com)

**SEE THE  
PRE-START  
BOAT PARADE  
10:00 AM OCTOBER 25  
SHELTER ISLAND  
SAN DIEGO**

**BROUGHT TO YOU BY THESE  
OFFICIAL SPONSORS**

**WWW.BAJA-HAHA.COM**



• Ultra Anchors • Ultra Swivels  
• Quickline Flat Rope & Reel • Ultra Trip Hooks  
• Ultra Chain Grabs, Ultra Snubbers & Ultra Bridles



[www.Quickline.us](http://www.Quickline.us)  
[www.UltraAnchors.us](http://www.UltraAnchors.us)  
sales@Quickline.us  
714-843-6964

*The Best Marine Products from the World, for the USA.*

**KATADYN**  
MAKING WATER DRINKING WATER

Watermakers that improve the cruising lifestyle.

**(800) 755-6701 • [www.katadyn.com](http://www.katadyn.com)**  
email: marine@katadyn.com

**MARITIME INSTITUTE**  
INCORPORATED

Advanced Training for safer, more enjoyable passagemaking!

**888-262-8020**  
[www.maritimeinstitute.com](http://www.maritimeinstitute.com)

USCG Approved Classroom & Online Courses

**Blue Sky ENERGY**

'Solar Boost' charge controllers that combine solar/wind/hydro output for cruisers.

**(800) 493-7877 [www.blueskyenergyinc.com](http://www.blueskyenergyinc.com)**

**La Paz Hotel Association**

November 18: La Paz Baja Ha-Ha Beach Fiesta on the Malecón at the Papas and Beer restaurant.

**011-52 (612) 122-4624**  
or **(612) 125-6844**  
[www.visitlapaz.org](http://www.visitlapaz.org)



**IMPORTANT DATES**

**Oct. 16** — Ha-Ha Welcome to San Diego Party, Downwind Marine, 12-4 pm. Ha-Ha entrants only.

**Oct. 23** — Informational Meeting about the Pacific Puddle Jump, West Marine, San Diego, 5 pm.

**Oct. 24, 9 am** — Final deadline for all crew and skipper waivers, West Marine, San Diego.

**Oct. 24, 11 am** — Skipper's meeting, West Marine, San Diego. Skippers only please.

**Oct. 24, 1 pm** — Ha-Ha Halloween Costume Party and Barbecue, West Marine, San Diego.

**Oct. 25, 10 am** — Fleet Parade through San Diego Harbor

**Oct. 25, 11 am** — Start of Leg 1

**Oct. 30, 8 am** — Start of Leg 2

**Nov. 3, 7 am** — Start of Leg 3

**Nov. 5** — Cabo Beach Party

**Nov. 6** — Awards presentations hosted by the Cabo Marina.

**Baja Ha-Ha, LLC**  
c/o 15 Locust Ave.  
Mill Valley, CA 94941

**WWW.BAJA-HAHA.COM**

PLEASE NOTE: Correspondence relating to the event can be emailed to [andy@baja-haha.com](mailto:andy@baja-haha.com). Please don't call *Latitude 38* with questions. The Ha-Ha is a separate operation.

**MARINA DE LA PAZ**  
**FULL SERVICE MARINA**

Conveniently located downtown

Tel: 011-52 (612) 122-1646  
Fax: 011-52 (612) 125-5900  
email: [marinalapaz@prodigy.net.mx](mailto:marinalapaz@prodigy.net.mx)  
[www.marinelapaz.com](http://www.marinelapaz.com)



**BLUE PELICAN MARINE**  
Nautical Consignments

*A Sailor's Consignment Chandlery*

Dealer for Lavac Marine Toilets

Located at Grand Marina

**[www.bluepelicanmarine.com](http://www.bluepelicanmarine.com)**  
**(510) 769-4858**



**Dedicated AIS Collision Avoidance**

**vespermarine**

"A really amazing piece of gear. I can tell it was designed by a sailor?"

**(858) 405-5810**  
**[www.vespermarine.com](http://www.vespermarine.com)**



**AIS WatchMate**

**THE BOAT YARD AT GRAND MARINA**

"Where Service Has Meaning"

Located in Alameda **(510) 521-6100**  
**[www.boatyardgm.com](http://www.boatyardgm.com)**

**Colligo Marine™**

Bringing innovative solutions to the marine industry.

Colligo Dux™ synthetic standing rigging • Emergency shroud kits  
Bridle plate mooring systems • Furlers and much more.

**(480) 703-3675**  
**[www.colligomarine.com](http://www.colligomarine.com)**



# MAX EBB

"Where did all the water go?" I almost said it out loud when I saw the angle of the gangway and the mud flats around the edges of the harbor.

My having neglected to check the tide table that morning, and having been away from the marina all week, this came as a surprise. I couldn't remember ever seeing it this low. Even the normally floating dock under the boat hoist was hard aground, listing over to one side and showing more freeboard than usual.

Lee Helm had talked me into crewing for a friend of hers, a university professor who had just bought a new sport boat, presumably made possible by a lucrative consulting project. It was not the kind of boat I was used to sailing: fractional with a roller furling, one-size-fits-all jib, big bowsprit with asymmetrical masthead spinnakers, very deep keel, twin rudders, and a deck-mounted boom, just like the Open 60s. Lee had promised that I would not have to hike very hard, and the clear morning air this time of year suggested we were in for a day of easy light air sailing.

If we could ever get out of the harbor, that is. This thing had a keel draft appropriate for a boat at least twice its size.

"Lee, I think the bottom is too close to the top," I said as the hoist beam swung out over the seawall with the boat hanging from the chain. Viewed from that grounded float, it was much higher up in the air than I'm used to.

"Keel is, like, all the way up," Lee advised me as she pressed the down button.

There was not quite enough chain to lower the boat all the way down to the water, so we had to release our lifting tackle wires to get the hoist hook free of the tackle. Once free, even with the keel retracted, the bulb planted itself in the mud and the boat rolled over to one side.

"Uh, Lee, isn't this going to block the hoist till the tide comes up?" I asked

when she and the skipper joined me down on the dock next to the boat.

"I have fiendish plan," she replied, and hopped aboard. She unclipped the spinnaker halyard from the launching tube, connected a spinnaker sheet to the halyard, connected another spinnaker sheet to that one, and handed the end to me. I was now holding a line attached to the masthead that was many boatlengths long.

"Just walk over to that dock on the other side of the fairway and pull," she said.

The plan was fairly obvious. And once we had several people pulling, it seemed to work. The long halyard heeled the boat way over until the keel came free, and with the boat floating on its bilge we were able to slide it over to the guest dock where there was a little more water. But Lee was not happy with the result, for some reason.

"Solitons," she said as she pointed to the fairway that led from the dock area to more open water.

"Yes, those are nice ones. Robust structures for water waves, aren't they?" observed the professor.

It took me a while to figure out what they were looking at. It was those little waves, not much more than ripples, washing into the boat hoist area. But instead of coming in groups like normal waves, they were coming in one at a time, about 10 or 12 seconds apart. There was

not a breath of wind blowing, so the water between these little waves was dead flat.

"Notice that these waves don't have a trough," explained Lee. "Only a single moving crest, and no dispersion of energy into multiple crests and troughs as the wave advances, like the way a

deep-water wave disperses into a wave train."

"How is that possible?" I asked. "I seem to remember you trying to convince me that a wave is always losing energy to the wave behind it, and that the wave

*Small dinghies with fully retractable centerboards have advantages over their less flexible sisters.*



PETER LYONS / WWW.LYONSMAGING.COM

energy travels at only half the speed of the waves in a group of waves, if I have that right."

"For sure, in deep water," she replied. "Shallow water is different. You can, like, think of the wave as being slowed down by the bottom till it matches the speed of the wave energy. Then, if the shape of the wave is right, there are nonlinearities that tend to pull the wave back together, balancing the standard linear forces that would make the wave come apart."

"I guess seeing is believing," I said as I watched another solitary wave crest sweep over the shoal.

"How fast do you think they're moving?" Lee asked.

"I'd say about two knots, maximum," I guessed. "Maybe one-and-a-half."

"That means the water is about three inches deep," she informed me after hitting some buttons on her calculator watch. The waves move at the critical depth Froude number, which is the square root of gravity times depth."

"It works out that evenly?" I asked.

"Purely non-dimensional," she explained. "Gravitational acceleration is in feet per second squared. Multiply by



DUGALD DUNCAN

*A modern re-enactment of the soliton (ahead of boat) in the Union Canal near Edinburgh, where the phenomenon was observed by Scott Russell in 1834.*



depth and you have feet squared per second squared. Take the square root of the whole thing and you have feet per second, which is the critical speed of a shallow water wave. Speed over square root of gravity times depth is also known as the depth Froude number. And the wave resistance curves of boats totally do interesting things as they transition through this speed."

Lee produced a cellphone with a large screen that displayed a graph of water depth versus time, something I could understand.

"At least another hour until we have enough water to get out of here," she sighed. "Even with the keel all the way up."

We stowed gear on the boat, bent on the mainsail, loaded the spinnaker in the launcher, and synchronized our watches. But after every possible pre-race preparation we could think of, the water depth was still too shallow even for our retracted keel.

"Might as well wait back in the yacht club bar," I suggested, and we retreated to an inside table with a view of the launch area.

"Solitons were first identified by ship designer Scott Russell in 1834," said our professor-skipper after we had warm caffeinated drinks in hand. "He was watching some horses tow a barge down a canal near Edinburgh when the towline broke. He described a 'wave of translation' continuing out ahead of the barge, and followed it down the canal for miles on horseback. The math wasn't fully worked out till the 1960s, when the term 'soliton' was coined. Russell is

*"I would argue that racing Snipes was more tactical and, in some ways, more interesting than what we do in modern boats," I countered.*

better known for his hull design theories and his early demonstrations of the Doppler shift — he's the first person to put trumpet players on a railroad car."

"A soliton sounds a lot like a tidal bore, I would think," I said.

"No, tidal bores are more like shock waves, and usually involve a lot of turbulence and energy dissipation, similar to a hydraulic jump. But a soliton can exist

as a smooth wave form with almost no turbulence. Two solitons can even pass right through each other."

"Does the timing of those waves correspond to the time between the offshore swells?"

"Either that or it's, like, the natural frequency of the outer harbor," Lee surmised. "You'd have to time the waves during several different low tides to see if they correlate with variations in the offshore swell period."

The skipper looked at her watch, looked out at the harbor, and checked the start time again. "It's going to be close," she concluded, but we took comfort in the presence of several other crews waiting out the tide at nearby tables. With any luck there would be a postponement.

"Back when I started racing," I reminisced, "it was all in boats like Lightnings and Snipes. The centerboards came up flush with the bottom, the rudders kicked up or came off, and if the hull still drew too much water, to get past the mud we would all get out and push. A low tide never made us late for a start."

"But then, you were stuck sailing a Lightning or a Snipe," Lee pointed out.

"The racing was good," I countered. "And I would argue that it was more tactical and, in some ways, more interesting than what we do in modern boats.

And the great thing was that those same boats we were racing could also sail to the beach for a family picnic. Maybe that's why we usually had 20 or more for the local races, and upward of 60 at the annual regattas."

"Max remembers big," Lee remarked.

"Multi-purpose or so-called family boats are still being sold," said our skipper. "But people who want to race will naturally go for faster boats."

"Even so," I argued, "The utility of any

boat is diminished when it needs deep water to sail. Even with sportboats with retracting keels, you still need the keel crane to pull the thing up, and that's usually not part of the onboard equipment. I don't think I'd want to own any small sailboat that I couldn't sail up to a beach."

"It wouldn't be hard to design these boats with fully retractable foils," Lee

# MAX EBB

suggested. "They're most of the way there already."

"It's the single-purpose, only-good-for-racing marketing," proclaimed a sailor from the next table.

"The marketing is just following consumer demand," said another crew at his table. "These are the boats that we want to sail."

"No, it's the technology," interjected a crew from the table on the other side of ours. "Carbon and epoxy make these fast boats possible."

"It's really the rating rules!" added another sailor. "The new designs are so deep these days that there are hardly any big race boats that can even use the harbor. The rule doesn't penalize deep draft like it should."

"The culture of sailing has changed," insisted someone at the first table. "And the folks who want family picnics at the beach are all buying Jet Skis."

"Everyone's forgotten," repeated the first sailor from the other table, "that the tactical game is better in heavier boats."

With about six points of unresolved



MAX EBB

**Wave energy converts to solitons — crests but no troughs — across the shallow mudflat between a stranded dinghy and the shore.**

contention flying between the two tables surrounding ours, we decided that the solitons were now moving a little faster and the water depth, which Lee reminded us varies by the square of the soliton speed, must have increased. We decided

to give it a try.

The keel was all the way up, everyone was hiking hard to one side, and the little outboard was churning away at full power. We finally slid over the mud into just slightly deeper water.

"Note the angle of our Kelvin wave train," Lee said as we powered out over the shallows, still heeled way over. "Normally, all the wave energy is, like, contained within a wedge having sides at 19 degrees 28 minutes to the centerline. But that's in deep water, where the group velocity is half of the phase velocity. Remember that diagram I drew a few months ago when we met for lunch on the bridge over the lagoon in the office park?"

"How could I forget?"

"If you construct the same diagram with the wave energy moving closer to wave profile speed, the angle becomes wider. I'll show you after the race."

To my great relief, Lee forgot all about her Kelvin wave train diagram. It's left as an exercise for the reader.

— max ebb

**Owl Harbor MARINA**

Beautiful 20 acre greenbelt park

- Up to 30' no power/inside tie @ \$4.50 per foot
- 30'- 50' berths @ \$5.50 per foot
- Home of Andreas Cove Yacht Club

Located on Seven Mile Slough, just off the San Joaquin River

1550 W. Twitchell Island Road • Isleton, CA 95641  
916.777.6055 • [www.owlharbor.com](http://www.owlharbor.com)

OFFICIAL SPONSOR OF

Latitude 38's  
Delta Doo Dah 2  
July 31 - August 6



# The Newest Class on the Bay

## The Antrim Class 40

Congratulations to Buzz Blackett on his new Antrim Class 40, **California Condor**. The newest member of the fleet, which is already one of the most popular ocean racing classes in Europe, was built at Berkeley Marine Center.



The yard that works for you!

[www.berkeleymarine.com](http://www.berkeleymarine.com)



## KISSINGER CANVAS

Marine Canvas & Interiors  
STEVEN KISSINGER  
**(925) 825-6734**  
Covering the Entire Bay Area



- Biminis
- Boat Covers
- Cushions
- Sail Covers
- Headliners
- Awnings

## DODGERS

Side handrails and window covers included.

### OPTIONS

Aft handrail, dodger cover, sailing bimini.

*Free Estimates and Delivery*

**Service of the Month**

**MAINTENANCE**

While we're at your boat we can take care of your regular maintenance needs too!  
*More sailing, less work.*

**ADDITIONAL SERVICES**  
Bilge Cleaning • Detailing • Maintenance Washdown • Carpet & Cushion Cleaning

**Fully Insured & Marina Approved**  
*Serving the Bay Area Since 1986*  
Call now for a Free Estimate

**510 428-2522 or 415 457-6300**  
**[www.seashine.net](http://www.seashine.net)**

# THE RACING

Wow! That was a busy month Between the **Finn Gold Cup**, some big news on the **America's Cup** front, the **Melges 32 Worlds**, the **Express 27 Nationals**, the **Windjammers Race**, **Sarcoma Cup**, **Jazz Cup**, **Richmond Riviera Regatta**, and a whole host of other things you'll find in these pages, if you weren't sailing or at least spectating, where've you been?

## Finn Gold Cup

Briton Ed Wright put a wrong to right on September 4 by winning the Finn Gold Cup on the Bay. It's been an enigma of the class that the former world number one had never won a world title. He had come close on a number of occasions,



Ed Wright

but during the six day-regatta in San Francisco, he put together an incredibly consistent performance to take the Finn world title in the best possible way by dominating and winning the medal race. Spaniard

Rafa Trujillo took the Silver while another Brit, Giles Scott took the Bronze.

The final day started with race 11 for the rest of the fleet with Dutchman Pieter-Jan Postma leading round the top mark ahead of Swede Daniel Birgmark and Spaniard Alejandro Muscat. Birgmark took the lead on the first downwind and led round the remainder of the course to take his second race win of the week to finish 12th overall. Another Swede, Bjorn Allansson sailed well notching a second while third place went to Croatia's Marin Misura, securing him kept him 11th overall.

Oscar flag for free pumping downwind was raised on the first downwind leg and stayed up for the rest of the day with the

**Andy Casey, Phil Ramming, Forrest Gay and coach Robbie Dean made up 'Team California'.**



wind reaching 17 knots during the medal race for the top 10, which followed soon after race 11 was completed. This meant that Oscar had been raised on each and every downwind leg of the championship, giving the Jury very little to do.

The big question for the medal race was whether second placed Rafa Trujillo would go for gold or protect silver. It was obvious within minutes what his strategy would be as he stuck to third placed Giles Scott like glue and covered his wind all the way round the course. Scott was faster downwind and broke through twice but he couldn't gain enough boats to take the silver medal from the Spaniard.

Meanwhile, the regatta leader by 13 points, Ed Wright, won the pin end start and powered away, never headed during the entire race. He initially headed to the left and then crossed back to the middle without ducking a single transom. He rounded the top mark just ahead of Gasper Vincec, American Zach Railey, Thomas Le Breton, Brendan Casey, Mark Andrews, Andrew Mills, Trujillo, Ivan Kljakovic Gaspic and Scott. With Scott in last place Trujillo had done his work well.

Scott immediately went low and passed three boats leaving Trujillo at the back. With Wright sailing away from the fleet, the fight was now on for silver. Trujillo rounded the gate just behind Scott, but within a few tacks was back in control and taking Scott to the left hand side, which he thought was not favoured. Also going this way were Railey and Mills and they crossed back in second and third. Trujillo and Scott also came back into the fleet closer than Trujillo has planned and again Scott passed Trujillo downwind. But he needed to take two boats to take the silver from Trujillo.

It was a nervous last downwind for the Spaniard as Scott sailed away and he was left behind. Scott caught up the pack ahead but could not take any boats and finished ninth to take bronze, with Trujillo crossing in tenth to take the silver.

A clearly happy Wright said, "I am so excited. It's something I have been working on for a



ALL PHOTOS THIS PAGE LATITUDE/ROB EXCEPT WHERE NOTED

while. Last year I got close, but this year I did it. The last couple of days have been the best of the regatta. Really windy and really difficult sailing, but I am really so happy. I am tired, but it doesn't matter. It's over now."

Wright is renowned for being the fittest sailor in the fleet but commented, "I was surprised how fit the others guys were out there. But it does make a difference. It's nice to feel fresh each morning. I have put a lot of effort into this year did quite a lot of training over the summer and changed my body shape. Everything was gearing up towards this event. I am really happy."

"It was brutal at times. Just great sailing. The boat is a powerful boat and it's so taxing sailing here. I loved every minute of the week. Rafa has been training hard as well and was sailing fast. But it was good to actually get out there on the track and actually do some real sailing. I only had to get seventh in the final race and I managed to win it, which was even better so I am really happy with that."

"I just needed to stay near Giles and Rafa and it was apparent straight after the start that they were messing around



**The Berkeley Circle delivered for the 86 Finn sailors who showed up August 29 to September 4 for the Olympic singlehander's world championship, the Gold Cup; inset Rafa Trujillo.**

with each other so I could just sail my own race. I just kept a loose cover on them and it made life a lot easier. To win the last race is great. I feel like I am sailing fast and really excited going forward to the next event."

Fourth placed Railey said, "It was a good race and very intense. I went in fourth and very close with Thomas but I had a shot at third. So I wanted to try and push Giles back as much as I could, as he had to be last and I had to win the race, it was a tall order and I ended up second but he sailed very well after that."

"But I'll take fourth at a world championship, though it is disappointing not to be on the podium. That was the goal. I think I averaged a fifth and that was part of the goal coming in as we thought that would be enough for the podium, but there were three other sailors here who just sailed a little bit better than me. Ed, Rafa and Giles were the three best sailors here this week."

"It's probably the best regatta I have

sailed this year and if I can build on that this winter and work on stuff, then we'll get ready for the 2011 season.

Silver medalist Trujillo talked about his race strategy. "This morning I did my planning with my coach and we had two options. Either try to win the Gold Cup depending on the wind conditions or protect the silver. After we saw the weather conditions, we realized it would have been impossible to catch Ed and he made a fantastic start, so I tried to slow down Giles as I thought I was faster upwind though he was clearly faster downwind."

"I made a pretty good job of that and we had a nice fight with each other. I took him to the left and thought it was all over but we had more pressure and better shift and he made a fantastic job of the downwind. He was just flying and I was really worried he would catch up enough boats to take the Silver.

But congratulations to Ed and Giles and all the other Finn sailors here because I think we have had a really tough week."

"Now I have promised myself one or two months with no hiking! I think we have hiked enough in the last month. I am now 34 years old and this is my third Olympic campaign and I need to take care of myself. This kind of event is not good for me. There are a lot of juniors here at 1.95 metres and they were pushing us really hard."

[www.finngoldcup.com](http://www.finngoldcup.com)

### America's Cup Update

The match for the 34th America's Cup will be contested aboard hard-wing 72-ft catamarans in 2013. That was the main message from BMW Oracle Racing's press conference in Valencia on September 13.

While there had been plenty of what has turned out to be true speculation with regard to the AC 72 catamaran, the '13 date was a bit of a surprise, as was the announcement that the new, annual series of traveling events leading up to the Cup — dubbed the "America's Cup World Series" — would start in '11 with a one design 45-ft hard wing cat. The AC 45s will allow new teams a chance to come to grips with the new technology before building their custom AC 72s and 130-foot-tall, 2,800-sq.-foot wings for 2012. Another very pleasant surprise is that once the AC 72s come online, the AC 45s will be sailed for a "Youth America's Cup."

So what was the reasoning behind one of the most dramatic shifts in the history of the Cup?

"The America's Cup should be the best sailors in the world sailing the fastest boats on the planet," BMW Oracle

**Former Bay Area guy Louis Nady got some post-race moral support from Ed Bennett; the pair were 2-1 on the 1972 US Olympic team and were some of the first to quit their jobs and train full-time.**



# THE RACING

ERIK SIMONSON/WWW.H2OSHOTS.COM

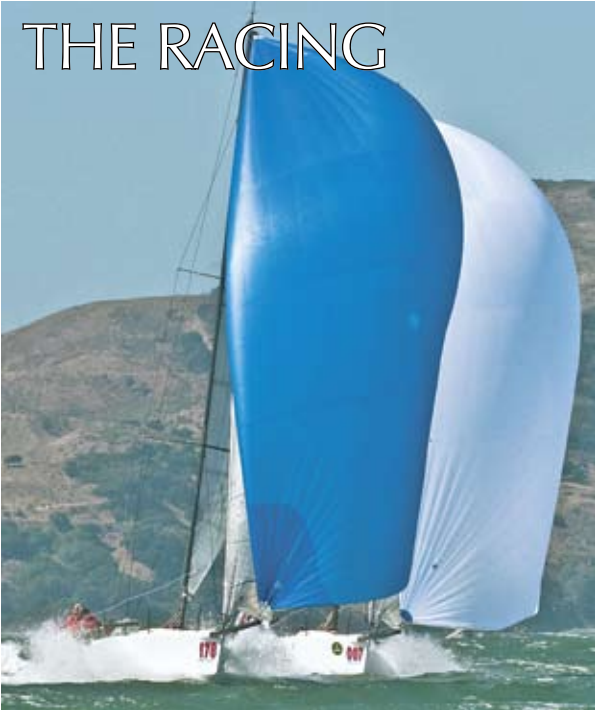

ERIK SIMONSON/WWW.H2OSHOTS.COM



ERIK SIMONSON/WWW.H2OSHOTS.COM



ELLEN HOKE/WWW.ELLENHOKE.COM



ELLEN HOKE/WWW.ELLENHOKE.COM



**Clockwise from above — Blast-off!** After a slow Rolex Big Boat Series, the Melges 32s got the best the Circle can bring for their World Championship September 22-25. Due to its late-breaking nature and the fact it was right after the Rolex Big Boat Series, we'll have to leave you with these photos; powering away from a weather mark; the flock takes flight; William 'Elvis' Douglass and the 'Goombay Smash' Girls; 'Bronco' gets launched; the celeb factor was high, here Russell Coutts signs autographs before a day's racing; feel small next to that sailplan? Luca Lalli (not pictured here, you can find him in the BBS feature) won.

Racing CEO Russell Coutts said in the conference call with reporters after the announcement. "If you looked at AC 32, there were a lot of sailors in their 40s and 50s; we want to bring that age range down. All of the crew are going to have super critical roles."

The new AC 72s will have a beam of 46 feet, and displace only 15,500 pounds. With a defined weight and stability, and given the fact the hulls have scantling

requirements for the outer skins, the boats should prove to be in a pretty tight ballpark.

Cup boats have to be the biggest, baddest boats out there; otherwise, there's nothing that sets them apart from the rest of the crowd. In the 12 meter era, maxi boats in the 80-ft range were the only monohulls that were larger and faster, but due to the fact that they were offshore-oriented and generally lower-tech, they

didn't effectively upstage the 12s and the Cup.

The problem with using monohulls is that of comparison: in today's world, there are canting-keeled monohulls like *Speedboat*, *ICAP leopard*, *Wild Oats XI* and the former *Alfa Romeo* that are already in the 100-ft range, and incredibly expensive to build — effectively the J Class of our era. Any smaller monohull would seem pedestrian by comparison, and anything



SHARON GREEN/WWW.ULTIMATESAILING.COM



ELLEN HOKE/WWW.ELLENHOKE.COM



larger would not only be prohibitively expensive, but severely limit the available venues due to the excessive draft required — even with a canting keel, which would in turn, require an engine — to provide the stability for a big monohull's commensurate sailplan.

Granted, *Alinghi 5* and *USA* dwarf the AC 72; but in the arena of both cost and logistics, multihulls that big are so far-fetched that it's unlikely we'll ever see anything like them again. The AC 72s will not have powered sailing systems, and will be demountable, allowing them to be packaged and shipped in 747 cargo plane,

a significantly less expensive option than the super-jumbo — and aged — Antonov cargo planes required to move around a V5 IACC boat. The AC 45s, on the other hand, go even farther in this direction: they will be able to be packed into 45-foot high-cube shipping containers. Coutts said that the performance of the AC 72s will be within a knot upwind and within a couple knots downwind of the monsters from AC 33.

Wing sails provide the most lift for the drag they produce, and unlike soft sails, don't require constant replacement. This should ultimately should see some sav-

ings for teams, which will now only build the maximum allotment of eight wing elements and buy gennakers. Multihulls lend themselves to wing sails because of the loads involved — remember that *USA's* mainsheet load went from 20 tons to 2 tons when they switched to the wing in the buildup to AC 33. The new rules will also allow the boats to be sailed with only 11 crewmembers — a significant savings in payroll for the teams, something that Coutts said represents at least 60% of their teams' budgets.

One theme to come out of our *'Lectronic Latitude* reader survey last month was

# THE RACING

the lamentation that traditional match racing tactics will become less important in multihulls. To a large extent this is true, and thank God for that! By AC 32, traditional match racing tactics had come to consist of getting into the box, dialing up and drifting backwards, sails luffing for three minutes. Gone were the days of

furious circling and using spectator boats as picks. There were few tacking duels as the confidence the teams had in their weather modeling encouraged them to stay in phase and try and take advantage of any perceived straight-

line speed edge.

Multis will allow more opportunity for passing on the race course — something that was all but non-existent in AC 32 — as their speed varies so much with regard to trim. If they're not optimally sailed, speed suffers at a higher percentage of their potential for a given condition.

Coutts also said he envisions shorter weather legs so that the boats round the first mark "nose-to-tail."

"In a high-performance multihull, you have to be precise in approaching marks," he said. "In these boats a reaching course could be tactical."

If sailing is going to make the jump to a wider audience and grab the attention of non-sailors, then the intricate particulars of match racing need to be minimized. In most professional sports a simple understanding of a few basic rules is all you need to know to understand what you're watching. Sailing's rules are far too complex to teach to someone who, to start with, doesn't know what port and

**Alan O' Driscoll's D-Class Catamaran 'Beowulf V' smokes into Benicia on the way to a new course record in the 25-mile Jazz Cup.**

starboard are. Plus, there is no real imperative that the America's Cup should be obligated to propagate the use of a set of arbitrary (albeit widely agreed-upon) rules.

In auto racing, which is probably the closest analog to sailboat racing on the worldwide stage, there is no pre-start beyond the establishment of pole positions. There are no pre-start tactics involved; the race starts when it starts, not five minutes before. The cars go around turns and down straightaways, and these features provide context for the viewer.

Would the Bay be too small to host these monsters? Coutts said that they've calculated that the AC 72s should be capable of making three laps of the main part of the Bay in about 45 minutes.

At first blush, this might seem to further the argument that the Bay is too small for these beasts to race on. But in response to our survey, one reader posed the question, "When was the last time natural marks were used in the America's Cup?"

In fact that's one thing that Coutts touched on in the conference call, saying that it would be more visually compelling for television if a course could run past landforms. Here at *Latitude 38*, we've long since given up on trying to get photos of boats racing offshore. Why? because one rhetorical question this poses is, "does a boat racing offshore look any more exciting than a boat close to land?" The only answer we can come up with is that in general, it doesn't. To take it a step further, having the variegated Bay as a backdrop would make for even more compelling visuals.

Imagine for a second what a course that started off Treasure Island, left Alcatraz to starboard, Red Rock to Port, Angel Island to port, Yellow Bluff to port, and back down to Treasure Island would look like. There would be parking lots where the race would effectively re-start. There would be straightaways where these machines would tear up and down the Bay at mach speeds in full view of huge numbers of people.

Using all of the Bay and its micro-climates and current variations would allow opportunities for passing lanes that don't exist in most venues. Which to our minds makes the Bay a prime option. Actually, check that, the only option.



CHRISTOPHER HARVEY

**JetStream in the Jazz Cup.**



JIM GOSSMAN

Coutts said that the consideration of having the multiple venues in the America's Cup World Series also pointed to the AC 72, as the cats will be highly adaptable to prevailing conditions and across the 5- to 33-knot wind range prescribed by the protocol.

"They'll be completely powered up in 5 knots, and you can de-power the wing pretty effectively," Coutts said.

That would play well into sailing the boats in the Bay's highly geographically-varied conditions also, as it would put a premium on the ability to change gears quickly.

Although a '14 date for the next match would have better played into the chances that the Bay will host it, we still think there's a chance. A high-powered organizing committee including people like Peter Stoneberg, Tom Perkins, Malin Burnham, and John Sangmeister, is proceeding at full speed with efforts to get the Cup



COURTESY BEOWULF V



**With the ebb, things got a little interesting at the buoy during the Jazz Cup.**

here.

"The City has said unequivocally that they can be ready for a Cup match in 2013," Stoneberg said. "The City has known that it would be a possibility and have been planning for it all along — it won't change the attitude of the City.

Coutts said there were a few main considerations for having the match in '13. Chief among them was to get the event back on track as soon as possible. Second was that having a three-year cycle effectively cuts a team's budget — which he estimated at between 40 and 100 million euros — by 25%. The third was that they didn't want the Cup to be competing for exposure with the FIFA World Cup in 2014.

Since the announcement, the Golden Gate YC has announced that '87 Australian Cup skipper Iain Murray — who

incidentally was a co-drafter of the IACC rule and intended it to be a skiff-like boat — will be the regatta director, which bodes well for the event as far as we can tell.

But what about America's chances for getting the next match? That, only a handful of people really know, and we're

not them. But what we can tell you is that there are some things you can do that would help the case. First of all, if you haven't already done so, fan the Bring America's Cup 34 to San Francisco Bay Facebook page, and implore all of your Facebook friends to do the same — let's try to multiply the page's 5,000-plus fans many times over. Second, send an email of sup-

port to Mayor Gavin Newsom at [gavin.newsom@sfgov.org](mailto:gavin.newsom@sfgov.org). Finally, possibly one of the most visible and effective ways to get right to BMW Oracle Racing's top brass would be to sail this year's Leukemia Cup, where Coutts will be the keynote speaker at Saturday night's dinner.

Then cross your fingers!

### Express 27 Nationals

A quality fleet of 16 Express 27s showed up at the Encinal YC September 10-12 for their national championship, and it took all seven races in the no-throut series to determine the winner.

After finishing second in Sunday's first race, Will Paxton and Zack Anderson's Richmond YC-based *Motorcycle Irene* held a one-point lead over three-time defending season champion Tom Jenkins' *Witchy Woman*. Jenkins had won that race, his fourth which set the stage for a final-race showdown between the two boats. With Brendan Busch's hull number one *Get Happy!!* just eight points behind, neither could afford to drive the other all the way back in the fleet.

When all was said and done, Paxton and Anderson won the race and the regatta. *Witchy Woman*, which had finished second, was ultimately chucked on a protest by another boat that dropped them to third and allowed *Get Happy!!* to slip into second.

"My match racing practice at the Lanes' really helped out," Paxton said of the pre-start in the last race.

"The regatta featured its customary buoy racing on Friday and Sunday on the Circle, and a distance race to Pt. Bonita on Saturday, which turned out to be a grueling affair. Starting off Treasure Island the fleet were forced to buck a four-knot flood out the Gate to Pt. Bonita, albeit in good breeze. Then, they were forced to sail in an ebb down the Estuary **Bob Harford's Express 37 'Stewball' steamrolls her way to Benicia.**



JIM GOSSMAN

# THE RACING

where it got agonizingly light.

Paxton and Anderson were joined by trimmer Matt Noble, fresh off six months on the East Coast where he was working on the shore team for Alex Jackson's Juan K 100 *Speedboat*. For the first day Mini sailor Emma Creighton filled in on bow for weekend bow girl Molly Robinson. They were joined by, wait . . . there wasn't anyone else? That's right, in a class where any competitive entry sails with five sailors, *Motorcycle Irene* was sailed by only four.

"We proved it can be done," Paxton said.

The youngest sailor in the regatta was 12-year-old Miya Miller who helped John Rivlin sail his *Peaches* to fifth overall.

"Miya did a great job," Rivlin said. "All on board were amazed at her boat feel and overall great attitude."

Also getting high marks were Encinal YC regatta chair Dan Pruzan and PRO Tony Shaffer, who everyone we talked to said put on a first class event.

*EXPRESS 27 NATIONALS (ENCINAL YC 9/10-12, 7r, 0t)*

1) **Motorcycle Irene**, Zack Anderson/Will Paxton, 12 points; 2) **Get Happy!!**, Brendan Busch,

**Sarcoma Cup founder and Sarcoma survivor Nat Criou and '10 Sarcoma Cup winner Kim Desenberg. The event grossed over \$32,000, with all of the operating costs covered by sponsorship.**

23; 3) **Witchy Woman**, Tom Jenkins, 31; 4) **Wile E Coyote**, Dan Pruzan, 37; 5) **Peaches**, John Rivlin, 38. (16 boats)

Complete results at: [www.encinal.org](http://www.encinal.org)

## Jazz Cup

Over one hundred boats showed up September 4 for the South Beach and Benicia YC's Jazz Cup. They were rewarded with a day that just got sunnier and breezier as it wore on.

Starting at Treasure Island in a light ebb, the reverse-start fleet was soon running hard down San Pablo Bay in breeze that reached the high teens toward the finish 25 miles away in Benicia.

Alan O' Driscoll's resurrected D-Class Catmaran *Beowulf V* took advantage of the conditions and set a new course record of just under 2 hours and 10 minutes to take elapsed-time honors, while Charlie Watt's Antrim 27 *Head Rush* corrected out as the first overall monohull. The Jazz Cup perpetual, awarded to the top finisher from either South Beach or Benicia YC went to the former and Doug Gooding's Islander 36 *Moondoggie*.

As you'd guess with a name like that, music played a big part in the after-sailing revelery, and the upper floor of the Benicia YC was jumping to what was probably one of the tightest bands we've ever heard at a regatta party. Complete results can be found at [www.southbeachyc.org](http://www.southbeachyc.org).

## Windjammers

Bill Turpin's R/P 77 *Akela* has been on a record-setting tear lately, most recently in



LATITUDE/ROB

the Spinnaker Cup, and Turpin and co-skippers Dave Janes and Doug Baker were hoping for yet another record for their big boat in this year's 68th Windjammers Race. But it wasn't to be, with a high-pressure system making for a race so slow on September 4 that a third of the fleet dropped out somewhere along the 67-mile racetrack from the St. Francis YC to Santa Cruz YC.

*Akela* finished after 9h, 17m, well off the record pace, and well down the leaderboard in Division A, won by Santa Cruz local Morgan Larson aboard the Melges 32 *Warpath*. In Division B, Mark Thomas' CM 1200 *Raven* finished nearly an hour ahead of the other three finishers in Division B.

Now, you'd figure that of all the divisions, the slowest boats in Division C



LARRY PHILLIPS

## THE BOX SCORES

Frankly we ran a lot short on space this month, so we have just a limited selection of results for you; we'll be wrapping up the rest of series that are coming to an end in next month's issue.

*GOLDEN GATE YC FRIDAY NIGHT SERIES FINAL CUMULATIVE (9r, 2t)*

SPINNAKER — 1) **Pajarito**, Ranger 23, Joe

Sheehy, 11 points; 2) **Late Harvest**, J/120, Modern Sailing, 18; 2) **Whisper**, J/105, Marc Vayn, 20. (6 boats)

NON-SPINNAKER — 1) **Mary Belle Bright**, Coronado, Bright Winn, 14; 2) **Snafu**, Canadian Sailcraft, Maurice Quillen, 17; 3) **Banana**, Cal 2-29, Wayne Carley, 18. (7 boats)

Complete results at: [www.ggyc.com](http://www.ggyc.com)

*BALLENA BAY YC FRIDAY NITE GRILLERS SERIES (12r, 2t)*

PHRF — 1) **Tortfeasor**, Olson 34, Jeff Rude, 13 points; 2) **Dixie**, Pearson 10M, Dan Watson, 34; 2) **Legendary**, Jeanneau 41, Dave Edwards, 39. (10 boats)

Complete results at: [www.bbyc.org](http://www.bbyc.org)





If you have to get dunked, the Encinal YC pool is the place to do it, not the Estuary; bottom right, from left to right, Express 27 National Champions Matt Noble, Will Paxton, Emma Creighton, Molly Robinson and Zack Anderson ask Brendan Busch: 'Hey didn't you read the sign?'

would show the highest rate of retirement, but this wasn't the case. Nine of the 11 starters finished, and when the corrected times had been calculated, David Nabors' Olson 34 *Temerity* came out on top, finishing an hour ahead of Dylan Benjamin's Dogpatch 26 *Moonshine*. Nabors and his crew of daughter Annika, Deb Fehr and Paul Harris kept the boat moving through the night and never gave up despite seeing goose eggs on the speedo at times. Nabors said that Fehr had the quote of the race.

"Deb pointed out after we had tied up

in S.C. after the race, 'You know, nobody even mentioned bagging it and motoring in,'" he said.

#### WINDJAMMERS RACE (SANTA CRUZ YC 9/3)

OVERALL — 1) **Warpath**, Melges 32, Morgan Larson; 2) **Raven**, CM 1200, Mark Thomas; 3) **Ocelot**, Fox 44, Kevin Flanigan; 4) **Chayah**, 1D48, Jesse Cartee; 5) **Scorpio**, Wylie 42, John Siegel. (31 boats)

PHRF A — 1) **Warpath**; 2) **Ocelot**; 3) **Chayah**. (10 boats)

PHRF B — 1) **Raven**; 2) **Scorpio**; 3) **RAM**, J/130, Robert Milligan. (10 boats)

PHRF C — 1) **Temerity**, Olson 34, David Nabors; 2) **Moonshine**, Dogpatch 26, Dylan Benjamin; 3) **Redhead**, Cal 40, Walter Smith. (11 boats)

Complete results at: [www.windjammersrace.org](http://www.windjammersrace.org)

#### Sarcoma Cup

A venue change didn't hurt the third edition of the Sarcoma Cup, which drew an impressive fleet of boats to Berkeley YC August 28-29. Split between six one design and two PHRF divisions, 67 boats showed up for Saturday's buoy racing, with 84 registered for the weekend. The J/105 fleet led the charge, drawing 17 boats, followed closely by the Open 5.70s with a whopping 13 boats! Nine Express 27s, five Wabbits, five Alerion Expresses and five Viper 640s were joined by 13 PHRF boats on two courses, one on the Circle and another on Southampton. With the breeze a little lighter than the 30-plus knots seen in the Slot closer to the Gate that day, there weren't a whole lot of letter scores in the results.

Adam Spiegel's *Jam Session* took the J/105 division, while Tom Baffico's nameless, brand-new Open 5.70 carried that division — some boats had traveled from Southern California — in his first regatta in the boat since trading down in size from an Express 27. Two-time defending season champion Tom Jenkins and his crew from the Morro Bay YC on *Witchy Woman* took the Express 27 division, while Tim Russell's *Weckless* was the top Wabbit. Ralf Morgan's *Ditzzy* took

the Alerion Express 28's, while the Viper 640 honors went to Ike van Cruyningen's *Ilex*. PHRF A went to Henry King's Frers 40 One Ton *Jeannette*, while Daniel Coleman's Olson 25 *Balein* handled everyone else in PHRF B.

After the boats hit the dock and the sailing gear was hung out to dry, it was time for the après-sail. With kegs and wine providing the lubricity, those who didn't end up in an ambulatory food coma after the dinner spread put out by the club hit the dance floor for some shake 'n' bake to live music — and even a karaoke performance by a J/105 sailor who will go unnamed. There was a silent auction and chair massages for the weary, and probably more than a few bleary-eyed sailors who showed up for Sunday's pursuit race, won by Kim Desenberg's Wabbit *Mr. McGregor*. The J/105s and Alerion Expresses sailed another day of buoy racing. The event raised \$32,000 to help the significantly underfunded sarcoma research, while 100% of the event cost was covered by sponsorship. You can find complete results at [www.sarcomacup.org](http://www.sarcomacup.org).

#### Richmond Riviera Regatta

When members of the Richmond Yacht Club voted earlier this year to "Give Where You Live," and hold a charity regatta for Richmond-based charities, some said it was the first time that the club had acknowledged the serious problems in its own city. The Richmond Riviera Regatta [richriv.com](http://richriv.com) on August 21-22 was envisioned as being a little different from the other two huge regattas the club holds each year, the Big Daddy and the Great Pumpkin. Because of the late August date, the event was envisioned as an ideal Rolex Big Boat Series tune up regatta. So the format was three buoy races on Saturday, and a classic long Bay Tour race on Sunday.

Two course areas were used: a "deep water" course, with a Treasure Island starting area again similar to the RBBS with all the wind the Slot can deliver, plus the "Riviera" course in the vicinity

#### CORINTHIAN YC FRIDAY NIGHT SUMMER SERIES FINAL (8r, 0t)

NON SPINNAKER 3 — 1) **Chica**, Cal 20, Ted Goldbeck, 12 points; 2) **Roadrunner**, Ranger 23, Gregory Demetruilas, 13; 3) **Sweet Reward**, Santana 22, Craig McDow, 20. (6 boats)

NON-SPINNAKER 1 — 1) **Q**, Schumacher 40, Glenn Isaacson, 9 points; 2) **Willow**, Centurion

40s, Bob Braid, 18; 3) **Jarlen**, J/35, Robert Bloom, 22. (12 boats)

NON SPINNAKER 2 — 1) **Mimicat**, Hinckley 38, Robert Long, 8 points; 2) **Fantasea Islander**, Islander 28, Kevin Reilly, 17; 3) **Maxine**, Yankee 30, Stephen Spoja, 20. (9 boats)

J/105 — 1) **Alchemy**, Walter Sanford, 14 point; 2) **Yikes!**, Peter Stoneberg, 15; 3) **VIM**, Garry Gast, 28. (9 boats)

SPINNAKER 2 — 1) **Nothing Ventured**, Melges 24, Duane Yoslov, 20 points; 2) **Shenanigans**, Express 27, Bill Moore, 26; 3) **Tiburion**, SC 37, Steve Stroub, 26. (16 boats)

SPINNAKER 3 — 1) **Wuda Shuda**, Soverel 26 OB, Craig Page, 11 points; 2) **Big Wow!**, Rhodes 19, William Royall, 13; 3) **Spirit**, Alerion 28, Nancy Rogers, 23. (7 boats)

Complete results at: [www.cyc.org](http://www.cyc.org)

# THE RACING

of Southampton, with North Bay courses, mellow winds and an easier delivery for boats with no motors. Entered boats could select their course area, and fleet splits were done from there.

Longtime RYC sailors said this may have been the first time RYC held racing on the cityfront. Conditions on that course were classic midsummer building breeze, with mild currents that made racing a battle of boatspeed and handling. Sunday's highlight was the Harding Gybe and a final weather mark rounding at Point Knox which created a "to set or not to set" dilemma in order to clear the Point Blunt buoy and go downwind to the finish line in the Berkeley Circle. On the Riviera Course there was also plenty of breeze, but the course was sheltered somewhat by Angel Island. The left became favored on the beats, but there were plenty of big shifts so it was possible to climb the ladder upwind.

The Etchells sailed as a one design



**Cal Maritime will be headed to France at the end of the month for the Student Yachting World Cup.**

class and along with the PHRF fleets the total was 35 boats. The parties were amazing for a new regatta. About 300 people attended "A Taste of Richmond"

on Friday night, which was the main fundraiser for the event, including a silent auction and the Freddie and the Freeloaders jazz band. Saturday night was the classic RYC party with Fast Times, a great 80s cover band (they were immediately rebooked for the Great Pumpkin — don't miss it), and Blue Lizard, a classic rock band on Sunday for the Prizegiving Party.

A long list of sponsors and donors for this regatta appears on the web page at [richriv.com](http://richriv.com). The regatta raised about \$30,000 for four Richmond charities: Bay Area Rescue Mission, Richmond Emergency Food Pantry, Rubicon Programs and Youth Enrichment Strategies. These are some of the groups doing good in Richmond right now, and the members of the Richmond YC are proud to support them in this small way.

— Scott & Eva Gordon

## Keelhaulers head for France

Cal Maritime will be the first West

## Check Out Rob Grant's Weekend Racing Wrap-Up

(Almost)  
Every Monday  
on  
*Electronic  
Latitude*



Photo: Peter Lyons  
[www.lyonsimaging.com](http://www.lyonsimaging.com)

SUBSCRIBE AT

[www.latitude38.com](http://www.latitude38.com)

3/6

Join Us!

ISLANDER 36 ASSOCIATION

**I-36 Nationals Regatta**  
Saturday, October 2, 2010  
Golden Gate Yacht Club

Race for bragging rights and cool prizes! Two or more races with a starting time of 12:00.

**Fall Meeting and Awards Dinner**  
Saturday, November 6, 2010  
Oakland Yacht Club

Celebrating the 2010 Racing and Cruising Season with dinner, awards, and our famous door prize raffle.

Visit [www.Islander36.org](http://www.Islander36.org) to join the Association and sign-up for our racing and cruising events.

Coast team to compete for the U.S. in the 30-year history of the Student Yachting World Cup October 23-29 in La Rochelle, France. The Keelhaulers won the right to represent the U.S. by taking college sailing's offshore championship, the Kennedy Cup, last fall.

Jessica Bernhard, Cole Davis, John Gray, Sara Himes, Sean Kelly, Sebastien Laleau, Thor Proulx, Kyle Vanderspek, Matt Van Rensselaer, and Evan Wamamaker will be trying to become the second-ever American team to win the event, which is sailed in Grand Surprise 32s.

"This is going to be a great opportunity to compete against the best student sailors in the world," said Cal Maritime's Sailing director Susan "Charlie Arms-Cartee." "But it is also going to be a huge challenge for us. Not only do we have to recover quickly from a lengthy overnight flight from San Francisco to Paris and train ride to La Rochelle, but we have to compete in a new venue with unfamiliar local weather conditions on a boat that will be new to us."

The Keelhaulers will be racing against

20 other teams from around the world, and the school is engaged in a fundraising effort to help offset the costs of the trip.

"It will cost us around \$40,000 to get them there and back, feed and house them, and pay all of our entry fees," Arms-Cartee said. "We're off to a good start, but we're reaching out to alumni, friends, supporters and the business community to help us with contributions big and small."

The team also has opportunities for larger donors to place sponsorship logos on the hull and sails during the competi-



YVANN ZEDDA

*Michel Desjoyeaux's brand new 'Foncia' will be headed away from France in the route du Rhum come November. Note the double chines.*

tion. They've set up a special TeamUSA blog, linked to the Academy's homepage at [www.csum.edu](http://www.csum.edu) or directly at <http://followteamusa.csum.edu>. There are detailed reports, photos and videos about



## Help Cal Maritime's Sailors Compete on the International Stage

Last year, the cadet sailors of The California Maritime Academy, Vallejo, CA, captured the National Collegiate Offshore Sailing Championship and designation as Team USA in the annual Student Yachting World Cup in La Rochelle, France October 23-29.

They will be competing against some of the world's top college teams. They are the first West Coast team to enter in the 30-year history of the Cup and could become only the second American team ever to take the top prize.

Your tax-deductible contribution of any size will help assure our ability to compete. Make payments to:  
**The California Maritime Academy Foundation**  
**World Cup Fund**  
 200 Maritime Academy Drive  
 Vallejo, CA 94590

See The Racing Sheet here for more details. Visit [www.csum.edu](http://www.csum.edu) for reports, photos and videos as the team prepares for and competes in the week-long Cup competition.



# THE RACING

their preparations, and this will be the primary outlet for updates during the event. Contributions can be made c/o The California Maritime Academy Foundation, 200 Maritime Academy Drive, Vallejo, CA 94590, and flagged for the World Cup Team Fund or online via the TeamUSA site. If you're interested in getting a sponsor logo on the boat during the regatta, contact Jennifer Whitty at (707) 654-1246 to find out more about that.

## A Cat North Americans

Seven West Coast sailors made the trek to the southwest shores of Lake Erie and the North Cape YC in LaSalle Michigan September 14-17 for the A Class Catamaran North Americans. A strong fleet of 43 boats including the likes of Randy Smyth, Matt Struble and five-time defending champion Lars Guck was almost complete — the only person missing was former world champ Pete Melvin, who had to skip the regatta to unveil the AC 72s in Valencia with BMW Oracle Racing.

With breeze that ranged from 5 to 25 knots the venue threw just about every challenge in the book at the fleet and the



**Santa Cruz's Paul Allen on his way to a fifth at the A-Cat North Americans in Michigan last month.**

West Coast sailors proved they were up to the task. San Diego's Struble finished three points clear of Rhode Islander Guck to win the regatta. Long Beach's Craig Yandow ended up in fourth, right behind

Floridian Smyth, and Santa Cruz's Paul Allen rounded out the top-five.

## Prince of Wales

St. Francis YC's Shawn Bennett and his team of Adam Roberts, Tom Purdy, and Melissa Purdy Feagin beat some of the country's best match racers to win the Prince of Wales Bowl for the U.S. Match Racing Championship on September 19.

Carrying over the momentum gained from defeating three-time champion Dave Perry in the semifinals the day before, Bennett upended number one seed Taylor Canfield in the finals by winning three straight races for his first Prince of Wales Bowl title. Bennett's team was a perfect 5-0 in the semifinal and finals combined and won the last seven races of their championship to finish the event with an 11-3 record overall. Two of their three losses came to Canfield and Perry in the round robin stage. Hosted by the Bayview YC in Detroit, the regatta was sailed in Ultimate 20s.

"It's a surprise more than anything," said Bennett. "I think the conditions came together for us. I've sailed a lot on Melges



**CELEBRATING OUR  
26th YEAR OF SERVICE**

## SAN FRANCISCO BOAT WORKS

835 Terry A. François St., San Francisco, CA 94158  
(415) 626-3275 Fax (415) 626-9172

[www.sfboatworks.com](http://www.sfboatworks.com) [info@sfboatworks.net](mailto:info@sfboatworks.net)

Be our guest for lunch at the historic Ramp Restaurant\*

\*Some restrictions apply



**for Savings!**

**TIME MARCHES ON...  
But boating weather  
is still perfect in  
the Bay Area!**

**Mention this ad for a  
"Fall Is Back"  
Discount**



24s, which are similar. The crew did a great job on calling the puffs. Taylor is a great starter but we were able to sneak by him."

Bennett was quick to compliment his crew after the win. "Tom Purdy was on bow and did an excellent job getting the sails up and down. Adam Roberts was trimming. He's a 470 sailor and did a great job too. Melissa Purdy Feagin connected the puffs for us and I think that made a huge difference."

By virtue of his win, Bennett qualified to represent the U.S. in the 2011 ISAF Nations Cup. He'll also receive an invitation to race in the 2011 Knickerbocker Cup and 2011 Ficker Cup, Grade 2 events and World Tour qualifiers.

#### Le Prof on the Prowl

On 20th September 2010 at 1533 hours, FONCIA, Michel Desjoyeaux' new 60 foot Imoca 60, was launched in Port-La-Forêt.

This latest VPLP/Verdier design, whose design was completed back in January, has been built and assembled in record time (6 months). Desjoyeaux and

his team now have 40 days to get the feel for the boat prior to the start of the Route du Rhum on 31st October 2010.

"Someone once said that the stage after 'demanding' was 'a real drag,'" Desjoyeaux said. "Well, I think I'm still at the upper stage! I've been involved in the whole thing, from the design through to tightening bolts in the yard. Of my 4 boats, I reckon I'll know this one best. To know the boat inside out has always been my leitmotif: the more you know about how



AMORY ROSS

*From left, Shawn Bennett, Adam Roberts, Melissa Purdy Feagin, and Tom Purdy are the new Prince of Wales Bowl champions and head for a Grade 2 match racing event.*

it's made, the better you can use it, even more so when the discovery period in the marine environment is short".



## Bluerush Boardsports

### STAND UP PADDLE CENTER NOW OPEN IN SAUSALITO

Full Service Sales & Rentals

Featuring **SLAM** Sportswear

C4 Bark Infinity Pearson Starboard  
Jimmy Lewis NSP SurfTech Laird  
Paddle Surf Hawaii Everpaddle Quickblade  
Werner Kialoa Kaenon Da Kine

**CLIPPER YACHT HARBOR**  
400 Harbor Drive, Suite A  
[www.bluerushboardsports.com](http://www.bluerushboardsports.com)  
(415) 339-9112



# WORLD

With a special report this month on **The Prime Sailing Venues of the Lesser Antilles.**

## **Eastern Caribbean Chartering: A Multinational Patchwork of Islands**

Here in the Bay Area we've had the dreariest summer in recent memory — *w-a-a-y* too many cold, gray days, and far too few splendidly sunny ones. No wonder we find ourselves jonesing for a sunny tropical sailing vacation. And we'd be willing to bet you feel the same.

So this month we'll take a look at some enticing possibilities for warm winter getaways in the sun-kissed isles of the Eastern Caribbean.

First, a little background. As every sailor worth his salt knows, the 500-mile chain of islands between the Virgin Islands and Grenada comprises one of the most idyllic cruising grounds on earth. With the promise of easterly trade winds blowing practically every day of the year, hundreds of well-protected anchorages, ample shoreside infrastructure, and perennially sunny skies, it's no surprise that more yacht chartering is done within this island chain — which cartographers call the Lesser Antilles — than anywhere else on Earth.

Beyond the region's physical characteristics though, much of its allure, when compared to other prime charter venues, is its multiculturalism. As every grade-school scholar should know, in the 1600s and 1700s, during the Colonial Era, European nations battled ferociously for control of these island

***Down in the British Virgins, where sailing is definitely a way of life, you'll find boats of all descriptions.***

gems. When the smoke finally cleared in the late 1700s England, France, Spain, Holland, Denmark and Sweden had all planted their flags in the turf of one island or another. And while most of these isles have now become independent countries, they all still maintain strong cultural links to their ancestral mother nations. As a result, traveling among them is an ever-changing cultural feast.

As cruising sailors quickly learn after arrival here, there are so many worthwhile places to explore, you could literally spend years sailing the Antilles chain and still not see them all. So the first task for prospective charterers with only a week or two to spare is to choose a portion of the group to sail in. For our purposes here, we'll break down the choices as follows: The Virgin Islands, the Northern Leewards, Antigua and Barbuda, the Middle Antilles, and the Grenadines and Grenada.

Before we discuss the distinguishing characteristics of each venue, though, we should point out that you can find well-maintained, late-model bareboats — both monohulls and catamarans — in each of these areas. (In the largest chartering markets, such as the BVI and St. Maarten, 'second tier' companies also offer slightly older boats at discounted prices.)

The Eastern Caribbean is also home to many of the world's finest crewed charter yachts. So if you're feeling flush, or have a special reason to splurge, you can choose from an eye-popping selection of luxury yachts, whose professional crews will spoil you with round-the-clock service. Most crewed yachts are based at either Antigua, St. Maarten or the British Virgin Islands, but by special arrangement many will pick up and drop off passengers just about anywhere along the

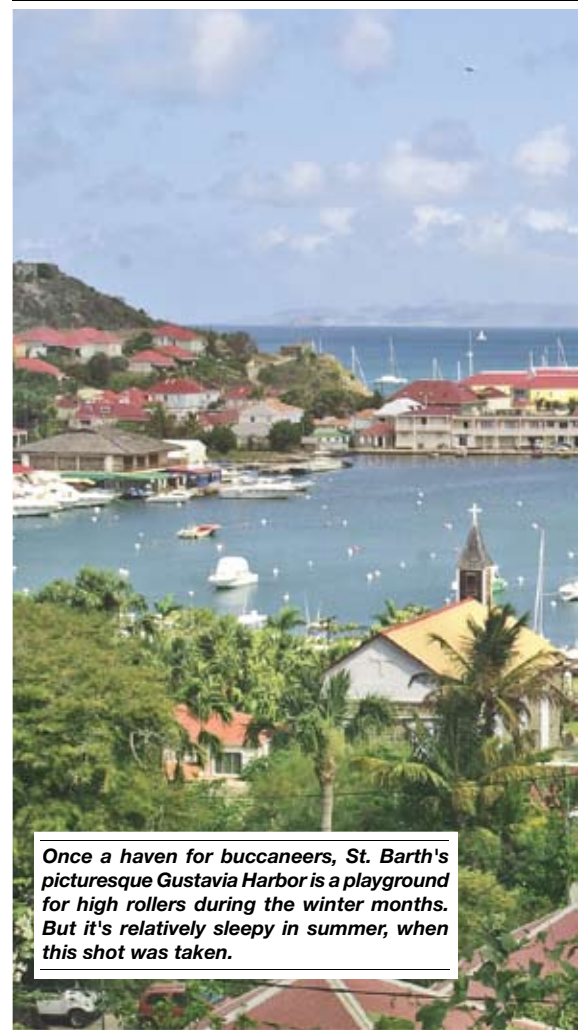

***Once a haven for buccaneers, St. Barth's picturesque Gustavia Harbor is a playground for high rollers during the winter months. But it's relatively sleepy in summer, when this shot was taken.***

island chain.

Only a few islands can boast non-stop flights from major U.S. gateways, but every island with a bareboat base is well served by short-hop flights from the major Caribbean hubs: Puerto Rico, St. Maarten and Barbados. While several Caribbean airlines offer island-hopper flights, American Airlines is the dominant force in the region, offering integration of both international and local flights — which means you can save yourself some hassle by checking your bags all the way from SFO, LAX or SEA to, say, Antigua, Guadeloupe or Grenada.

Another flight note concerns frequent flyer miles. We always suggest using your miles for travel to the Caribbean, as you tend to get a much better deal than when flying to other destinations. American charges you only 25,000 to 35,000 miles for a round trip to your final Caribbean destination, while a typical economy-class ticket might cost \$650 to \$1,000. By contrast, for an 'award ticket' to Europe you'll have to shell out nearly double that amount of miles, despite the



LATITUDE / ANDY

# OF CHARTERING

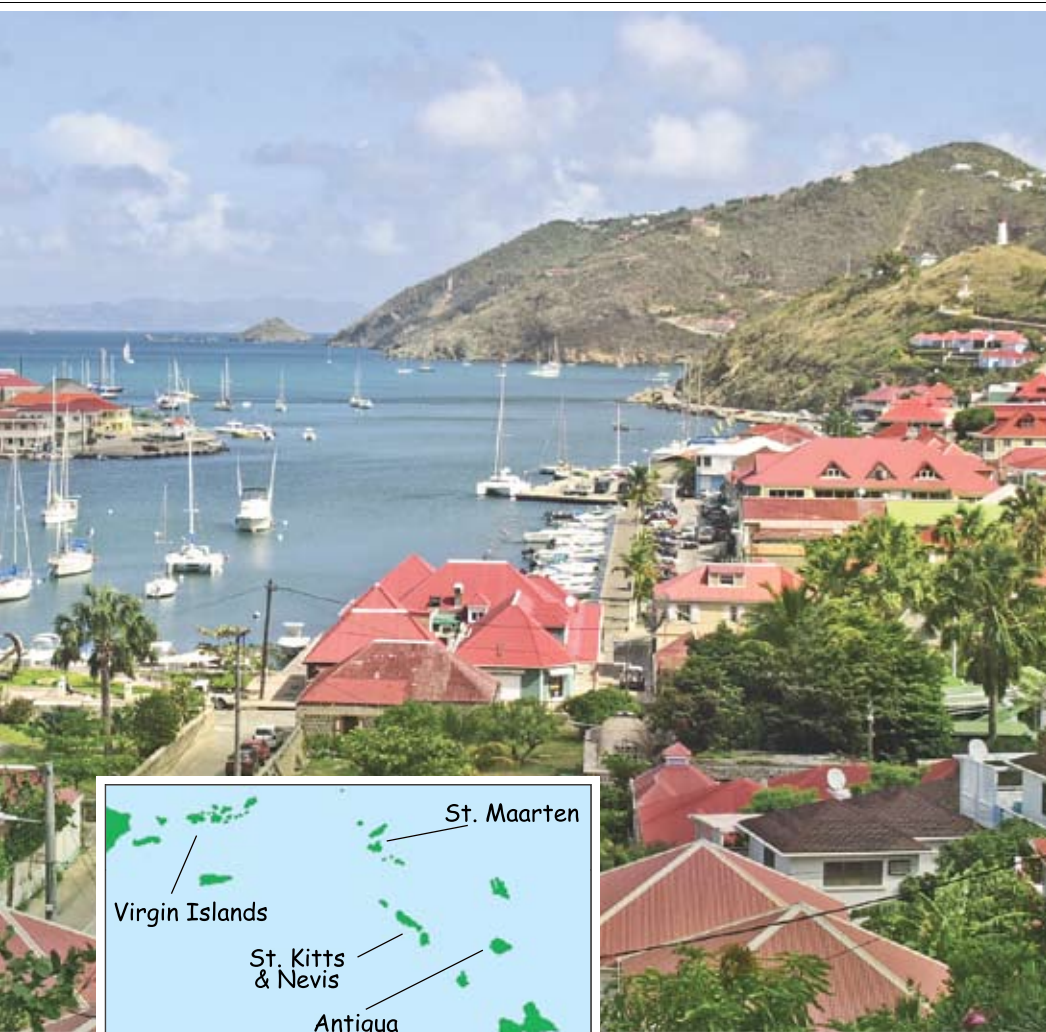

LATITUDE / ANDY

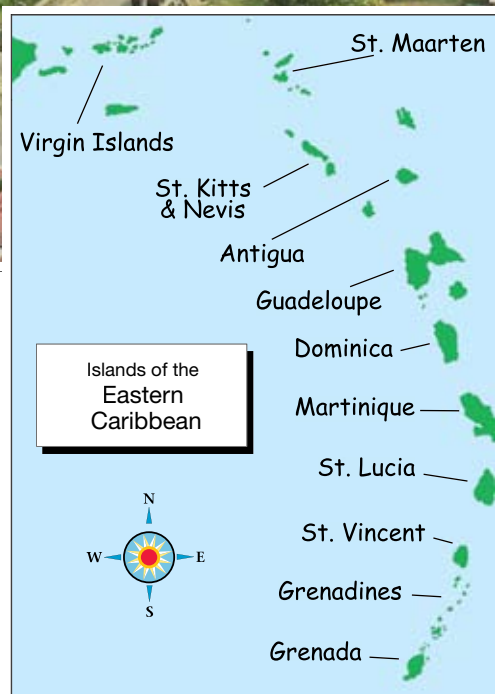

fact that there are many bargain flights to 'the Continent'. If you have miles on United or other carriers with limited Caribbean penetration, consider using them to get to Puerto Rico, then pay for an island-hopper from there to your final destination.

Most basic travelers' concerns are relatively painless in these islands. While Euros are used in the French islands and Eastern Caribbean (EC) dollars are used in most English-speaking islands, good

old American greenbacks are accepted almost everywhere, as are debit and credit cards. Be warned, however, that while ATMs are found in all airports and major towns, smaller and more remote islands may not have them.

Similarly, a wide variety of fresh provisions can be found on all large islands, while supplies at smaller isles will be limited. That said, every bareboat company in the region offers provisioning packages, designed to save you time and hassle. The goods you order in advance will typically be placed aboard your boat prior to your arrival.

If you're like us, part of the attraction of a sailing cruise in foreign waters is getting away from phones, faxes, TV and email. However, if you do need to

stay in touch, there's pretty good cell reception these days throughout the islands. But we suggest you become crystal clear on the roaming charges before leaving home. WiFi connections are becoming more prevalent every year, but you'll rarely find the level of bandwidth that you're used to at home.

Naturally, French is the official language of all the French islands, but with economies that depend on tourism, most shopkeepers, restaurateurs and service personnel speak at least some English also. On the Dutch islands, virtually everyone speaks English. And, of course, in all the formerly British isles English is the official language, although it might take you a while to get used to the subtleties of the distinctly Caribbean *patois* spoken by islanders.

As you peruse the following snapshots of key Caribbean sailing grounds, you may find it hard to choose just one section to sail in. If so, we suggest you consider doing a one-directional charter. Although you'll usually have to pay extra for the boat to be delivered back to its home base, such itineraries allow you to maximize the number of places you visit, while eliminating back-tracking — and, if you plan it right, minimizing windward sailing. Guadeloupe to the British Virgins in 10 or 12 days is a good example. We've done that trip twice ourselves. Whatever your game plan, though, we'd strongly discourage you from planning an itinerary so ambitious that you find yourself rushing from point A to point B. After all, one of your goals should be to relax and slow way down to the blissfully laid-back

***One of the joys of making landfall in the French Islands is the availability of genuine French pastries and piping-hot baguettes.***



KENT BENEDICT

# WORLD

pace of Caribbean living.

With that, let's look at the factors that distinguish one potential chartering venue from another.

*The Virgin Islands* — By far, more chartering takes place in the U.S. and British Virgin Islands than anywhere else in the Caribbean or the wider world. And the British half of the archipelago gets the lion's share of it. As you've undoubtedly read time and again, the BVI is the hands-down favorite choice for first-time charterers due to its well-protected waters, traveler-friendly infrastructure and the close proximity of its many islands. You can easily stop at one island for lunch and another for dinner with a snorkeling stop or two in between.

We've lived in these islands and done the 'BVI milk run' dozens of times, but we still never tire of sailing these waters. We'd be remiss, however, if we didn't point out that during the peak winter season the most popular anchorages can get pretty crowded — although the recession has substantially diminished this problem.



LATITUDE / ANDY

*In the British Virgins, "limin'" is a favorite pastime. That is, chillin' out and relaxing at a decidedly laid-back pace.*

Because water-borne tourism is the biggest 'cash crop' here, the government took unprecedented steps long ago to insure the longevity of its touristic ap-

peal. For example, the waters of the entire country are now a marine preserve, virtually all popular anchorages are peppered with well-maintained overnight moorings, and there are no high-rise buildings in the entire country.

Thanks to the availability of moorings, the aspect of chartering that's usually the most stressful for neophytes — anchoring — is virtually eliminated, and the coral on the sea floor now gets much less damage than previously. Because charter operations here are larger than almost anywhere else, fix-it boats can normally make a 'house call' to your boat in any anchorage within hours of a breakdown.

The must-see stops here are practically household names in the world of sailing: the boulder-strewn grottoes called The Baths and the world-renowned Bitter End Yacht Club (both on Virgin Gorda); the famous barefoot party bar on Jost Van Dyke called Foxy's; the idyllic, palm-lined crescent called Cane Garden Bay on Tortola; and the Norman Island treasure caves, where, according to a

"We had a true, worry-free 14 days of sailing. We got everything we asked for and then some!"  
A satisfied BVI Yacht Charters Guest

Join us at the Annapolis Boat Show 2010. Booth D42!



Call: +1 888 615 4006  
Or: +1 284 494 4289

BVI Yacht Charters is the first port of call for all yacht charters in the BVI. Whether you are looking for Bareboat or Crewed yachts, a Catamaran or a Monohull, a week or just a few days, our professional team is on hand to make it work, your way.

**BVI YACHT CHARTERS**  
[www.bviyc.com](http://www.bviyc.com)  
[charters@bviyc.com](mailto:charters@bviyc.com)

**Sail Mexico Aboard the Schooner Seaward ~ Winter 2011**

**Answer the 'Call of the Sea' Adventure Voyages to Mexico's Sea of Cortez**

Contact us now! Limited Availability!

**Be part of the adventure.** This is a hands-on opportunity for all levels of sailors to enjoy the pristine beauty of Baja and camaraderie with your shipmates.

<b>Log Angeles to Cabo San Lucas</b>	January 7-19
<b>La Paz to La Paz</b>	January 25-30
<b>La Paz to Cabo San Lucas</b>	February 28-March 5
<b>Cabo San Lucas to Los Angeles</b>	March 8-22
<b>Los Angeles to San Francisco</b>	March 24-29

These trips share the educational spirit of Call of the Sea's mission and help support our Youth Programs. *Seaward* is an 82-ft USCG-inspected vessel owned by Call of the Sea, a non-profit educational organization.

[www.CalloftheSea.org](http://www.CalloftheSea.org) • (415) 331-3214 • [info@callofthesea.org](mailto:info@callofthesea.org)



# OF CHARTERING

highly questionable legend, buccaneers once stashed their ill-gotten booty. After a week of sailing here, most first-timers will have built up enough confidence to sample more challenging sailing 'down island' — as the locals say.

*The Northern Leewards* — The 90-mile Anegada passage separates the BVI from the northern end of the Leeward Antilles, where the half-French, half-Dutch island of St. Martin/St. Maarten is the principal charter base. From here, you could sail all the way to Grenada by line-of-sight navigation. That is, your next target would never be beyond your range of vision. So, needless to say, inter-island sailing distances are relatively short and navigation is relatively easy throughout the chain.

If you like cultural diversity, chartering out of St. Maarten should be high on your wish list. This sophisticated French/Dutch island offers duty-free shopping, casino gambling, many fine restaurants and at least one world-famous nude beach. But only a day's

sail away, at either the Dutch islands of Saba or St. Eustatius, or the formerly British islands of St. Kitts and Nevis, you'll think you've stepped back in time due to their minimal development and 'old Caribbean' flavor. Mix in a visit to the chic French island of St. Barth — favorite isle of rock stars, royalty and tabloid celebs — and you've got a charter itinerary that offers something for everyone.

Some of the region's highlights are world-class diving at Saba, climbing the battlements of the historic Brimstone Hill fortress on St. Kitts, visiting Nevis' thoughtfully refurbished plantation-



DEBBIE COLLIER

**On Barbuda, Codrington is the only real town. And this friendly watering hole is the most popular place for a cool brew.**

hotels, and clubbin' in St. Maarten.

The lay of the land is such that you can do a highly-varied tour in a week, and the inter-island passages are often lively.

**Real People. Real Sailing. Real Fun.**

Sail Cats | Power Cats  
Monohulls | Trawlers  
Bareboat | Skipped

**Real Choices.**

Choose CYOA and become part of the family. We've been providing beautifully maintained yachts, personal service and sensible prices to sailors since 1980.

1-800-944-2962  
info@cyoacharters.com  
www.cyoacharters.com  
St. Thomas USVI 00802

**CYOA**  
YACHT CHARTERS

Tortola BVI  
Belize  
The Grenadines

**UNIQUELY**  
**TMM**

Most charter companies offer blue water & palm trees, but it takes the personalized care of people like Marisa to make your vacation a success.

Like Marisa, everyone at TMM is committed to your complete satisfaction. Our specialized three-location operation offers large company quality with small company service. A combination that is uniquely TMM.

**TMM**  
Yacht Charters  
Since 1979

catamarans • monohulls  
motor yachts  
ownership programs

Marisa  
TMM Belize

# WORLD

*Antigua and Barbuda* — In the world of sailing, the two-island nation of Antigua and Barbuda is best known for its annual springtime Sailing Week — the Caribbean's biggest and most prestigious regatta — which draws entries from up and down the island chain, as well as from Europe and North America. But racers often miss some of the island's more unique attractions, such as exploring colonial-era hilltop battlements and the refurbished buildings of Nelson's Dockyard, where England's West Indies Squadron once serviced its warships.

Tourism folks like to say Antigua has a beach for every day of the year. We're not so sure about that arithmetic, but we'll concede that there are *plenty* of them, in addition to a wealth of secluded anchorages within the reefs and islets of its northeast side.

But the thing that literally every racer — and most charterers — miss here is the sister island of Barbuda. With only a tiny population, a couple of small hotels and minimal infrastructure, this oblong, reef-fringed island is truly a 'sleeper' among Caribbean destinations. We think



LATITUDE / ANDY

**Light air? No worries. One of the goals of every Caribbean charter should be to chill out, slow down and find your 'inner beachbum'.**

the tranquility of its endless white-sand beaches and the promise of excellent snorkeling on unspoiled reefs make it

well worth the 50-mile round-trip sail from Antigua's north coast.

*The Middle Antilles* — For lack of a better name, we'll refer to the large French islands of Guadeloupe and Martinique, plus the formerly British isle of Dominica — which is sandwiched between them — as the Middle Antilles.

Both Guadeloupe and Martinique offer a mix of big city sophistication and the funky charm of waterside fishing villages. Relatively few Americans focus their travels on either island, or on Dominica, which is one of the least-developed islands in the entire Caribbean. But to our way of thinking that makes them all the more appealing. Unlike their drier northern cousins, these large islands have lush rainforests, rivers, waterfalls, and plenty of home-grown agriculture. Because both Guadeloupe and Martinique are departments of France (like our states), their citizens enjoy full rights as French citizens, trips to Paris are considered to be "domestic flights," and the supermarkets carry a wide range of

**Income? Moorage?  
Tax Saving?**  
Ask Bellhaven about the advantages of charter boat ownership.

**Bellhaven  
Yacht Sales  
& Charters**

- San Juans
- Gulf Islands
- Desolation Sound

Power & Sail Charters  
ASA Sailing & Power School

[www.bellhaven.net](http://www.bellhaven.net)  
[bellhaven@bellhaven.net](mailto:bellhaven@bellhaven.net)  
877-310-9471

BELLINGHAM, WA



**VALLEJO MARINA**

*Gateway to the Bay & Delta*

**Ask us about our FALL SPECIALS on guest docking**

- Competitive Rates!
- Ample Guest Dock
- Full Service Boat Yard and Chandlery
- 2 Restaurants for Breakfast, Lunch, Cocktails and Dinner
- Covered and Open Berths



**(707) 648-4370** • Fax (707) 648-4660  
42 Harbor Way • Vallejo, CA 94590  
[www.ci.vallejo.ca.us](http://www.ci.vallejo.ca.us) [marina@ci.vallejo.ca.us](mailto:marina@ci.vallejo.ca.us)

**How to Read  
Latitude 38  
in the Azores:**

Download our eBooks  
**FREE!**

[www.latitude38.com](http://www.latitude38.com)



# OF CHARTERING

French delicacies. Needless to say, you can find fine French cuisine in the cities, plus authentically flaky — in the best sense of the word — pastries.

In this central stretch of the Antilles, inter-island passages tend to be substantially more challenging than in the Virgins or down-island in the closely-clustered Grenadines. Neophytes might consider that fact to be daunting, but more experienced sailors tend to define 20 to 25 knots on the beam as big fun. While sailing in the lee of these tall, mountainous islands you'll often find relatively gentle land breezes and flat water.

Among our favorite spots here are Martinique's St. Pierre, whose one-time sophistication earned it the moniker 'Paris of the Caribbean' before nearby Mt. Pelée erupted violently in 1902, wiping out all but two survivors: a cobbler who was at work in his cellar and a murderer, condemned to an isolated cell. Despite that grim history, the town has been fastidiously restored, and its museum is well worth a look.

On Dominica, a must-see for every sailor is a guided small boat ride up the heavily jungled Indian River, near the town of Portsmouth. And if you like to hike, don't miss the chance to explore the island's primeval rainforest via well-established trails.

When visiting Guadeloupe, our favorite stopovers are at near-shore Pigeon Island, which boasts some of the best snorkeling and diving in the Caribbean in its Cousteau National Park, and the idyllic cluster of islands called Les Saintes, where life is slow and sweet.

*The Grenadines and Grenada* — Most St. Lucians probably wouldn't be pleased with us for lumping their island in with its southern neighbors. But we'll do so



LATITUDE / ANDY

**A family sailing vacation in the Eastern Caribbean is sure to yield lasting memories — and your kids will never be bored.**

here because many Grenadine charters begin at the long-established charter bases of St. Lucia's Marigot Bay and Rodney Bay.

Another tall, lush island with prolific

## Custom Canvas & Interiors



The Gianola Family has been designing and fabricating custom canvas and interiors since 1969. Gianola Canvas Products offers you the best in quality, more choices, and personal service.



265-B Gate 5 Road  
Sausalito, CA 94965  
(415) 332-3339  
www.gianolacanvas.com



*A wild downwind ride.*

A new 20-foot club racer with carbon-fiber keel, spars, bowsprit and rudder. Lightweight and trailerable.

LOA	LWL	Beam	Draft	Displ.	Spar
19' 6"	18' 0"	5' 11"	4' 6"	835	Carbon

*Ready to Race for \$24K*

landingschoolboats.com

207-985-7976

# WORLD OF CHARTERING

agriculture, St. Lucia's most famous attractions for sailors are the twin tooth-like peaks called the Pitons. Most sailors simply marvel at their verdant beauty from the comfort of their cockpits while anchored at nearby Soufriere Bay. But if you're fit and full of energy, a hike to the top of either pinnacle will give you a spectacular panoramic view.

The large, agricultural island of St. Vincent defines the northern end of the Grenadines. While lush and beautiful, its main attraction for sailors is its charter bases, located in the far south. The Grenadines themselves are a cluster of small islands and cays, renowned for easy sailing in protected waters, with short hops between anchorages.

Like the Virgin Islands to the north, the entire cluster of Grenadine islands, from Bequia in the north to Grenada in the south, are part of one broad archipelago, but somewhere along the line it got chopped in half. As a result, the relatively large island of Carriacou — where islanders still build hand-hewn sloops on the beach — is aligned with Grenada. Regardless of which end you start at,



LATITUDE / ANDY

**The Eastern Caribbean is full of curious things, such as this rocky pinnacle near Antigua, which is officially named the Kingdom of Redonda.**

it's easy to clear into and out of either country. And given enough time — 10 days or more — it would be wonderful to explore this entire string of gems in one direction or the other.

For us, the highlights here are kicking back in the tranquil anchorages and

friendly beach bars of Bequia, snorkeling on the massive reefs of the Tobago Cays, seeing if we can catch a glimpse of an international celeb at the uniquely upscale island of Mustique, and watching the shipwrights practice their ancient artistry on Carriacou.

Grenada itself is a charming island with one of the most beautiful harbors — St. George's — we've ever seen. If you begin or end your charter there, be sure to take a taxi tour of the island's rich interior and you'll soon know why it's long been known as the 'spice island'.

This once-over-lightly overview of the Lesser Antilles doesn't even begin to describe all that these islands have to offer. But hopefully we've given you enough food for thought to inspire you to expand your research.

There's no doubt about it, winter is on its way. To ease the pain, our advice is to shanghai a crew of spirited sailors and lock in a booking for a winter getaway in the Antilles. We think you'll find that it's the perfect antidote for the gray sky blues.

— latitude/andy

WINDEX INNOVATION

**WINDEX 15**  
Now with **Bird-Proof Spike!**

**Why Windex 15 is the choice for most sailors:**

- 15" wind vane (38 cm)
- Sapphire suspension bearing
- Adjustable tacking arms with tabs
- Vane and tabs feature reflectors for high visibility day and night
- Weighs just 3.9 ounces (111 grams)
- Stands 12.75" tall (32 cm)
- Bird-proof spike extends another 10" (24 cm) above vane to discourage birds from landing.

The versatile J-Base can be purchased for Windex 15 to allow top or side mounting.

Contact us for your FREE copy of the latest **DAVIS** catalog.

**Davis Instruments** 3465 Diablo Ave., Hayward, CA 94545 U.S.A.  
Phone 800-678-3669 • Fax 510-670-0589 • E-Mail info@davisnet.com  
[www.davisnet.com](http://www.davisnet.com)

**Advanced LED Navigation Lighting**

See us at the Annapolis Boat Show at the North East Rigging Systems booth #L6-8

Super Bright  
Waterproof  
Multiple Color Configurations  
Excellent Viewing Angles  
Lifetime Warranty

Available at: **SVENDSEN'S MARINE**

Call or visit our website to learn more about our quality lighting products.

[www.LunaseaLighting.com](http://www.LunaseaLighting.com)  
1.800.272.0170

RoHS compliant **FC CE**

**LUNASEA LIGHTING**

# LOCH LOMOND MARINA

**Slips Available:  
53-ft, 46-ft  
and 40-ft**

**Completely Rebuilt Marina • Gas & Diesel Fuel Dock • Free Pump Out Station  
Modern Launch Ramp • Guest Slips Available • Marine Mechanical Boat Repair  
Arena Marine Supply Store • Andy's Local Market • Bait Shop  
Land or Sea Canvas • Windjammer Yacht Sales • Loch Lomond Yacht Club**

**110 Loch Lomond Drive, San Rafael, CA 94901**

**Phone: (415) 454-7228 • Fax: (415) 454-6154**

**www.lochlomondmarina.com**

**Harbor Master – Pat Lopez • pat@lochlomondmarina.com**



**Bilge Steam Cleaning Oil Changes**

Professional service at your slip!!!



**Fuel Polishing**

**Tank Cleaning**



**QUALITY CUSTOM CRUISING SAILS FOR LESS!**

**LEE SAILS**

**NOW  
10%  
OFF**

**MAINSAILS  
MIZZENS  
STAYSAILS  
HEADSAILS  
SPINNAKERS  
SAILCOVERS  
STRONGTRACK**

(510) 290-0955 • leesailsnc@yahoo.com

2021 Alaska Packer Pl. • Grand Marina • Alameda, CA 94501

**SAILMAKER TO THE WORLD SINCE 1947**

**DF DIESEL FUEL FILTERING**



**Purify Diesel Fuel & Flush Tanks**

Process scrubs, polishes, removes algae, dirt, sludge, rust, water, and foreign particles from diesel fuel. Includes internal tank washdown. Save your injectors, costly engine repair and down time.

Since 1989. Fully insured. Your berth or boat yard.

**(510) 521-6797 Fax: (510) 521-3309**

**www.dieselfuelfilterings.com**



**MARINE BATTERIES**

**LIFELINE**  
...the heart of your system®

Available at the following local marine chandleries and service distributors:



**ALAMEDA**

- Alameda Prop & Machine
- Fortman Marina Store
- The Boatyard at Grand Marina
- Star Marine
- Svendsen's Chandlery

**BENICIA**

- Cruising Seas Services

**MARTINEZ**

- Diablo Marine

**OAKLAND**

- Golden State Diesel
- Outboard Motor Shop

**OAKLEY**

- Big Break Marina

**RICHMOND**

- Swedish Marine

- Bay Marine

**SAUSALITO**

- Sausalito Marine

**AMERICAN BATTERY • Hayward, CA • (510) 259-1150**

# CHANGES

With reports this month from **Cocokai** on the death of Ducky in the Solomon Islands; from **Geja** in Albania and Greece; from **X** in Malaysia; from **Niki Wiki** on satisfactory but inexpensive surgery in Guatemala; from **Sea Level** in Fiji on the flipping of the cat Anna; and **Cruise Notes**.

## **Cocokai — 65-ft Schooner Jennifer & Coco Sanders, Greg King The Death of Ducky the Dog (Long Beach)**

It's with great sadness that I have to report the passing of our lab Ducky, the best dog ever! In the last month or so she had been weakening, but we were hopeful, as she seemed to be doing all right after a visit to the vet in Vanuatu last month. She was having fewer seizures and even started swimming again.

But three days ago, Ducky started going downhill fast. Her legs could no longer consistently support her, and she was going blind and deaf. We put her in her big bed in the aft cockpit, babied her with special meals, and held her food and water in front of her because she could no longer sense them with her nose. She could hardly move.

Two days ago we arrived at beautiful Marau Sound on the southern tip of Guadalcanal in the Solomon Islands, and anchored off of Tavanipupu Isle. This lovely large bay is protected by many islands, and is very serene and peaceful. We decided that it would be the perfect final resting place for our Ducky. As her heart still beat strongly, it took until yesterday afternoon for us to get up the courage to give her the fatal injection. But as her quality of life was all but gone, we had no choice.

*Coco and Jennifer's wonderful years cruising the South Pacific with their black lab Ducky will never be forgotten.*

Giving Ducky the injection — with Greg holding her for me — was the most difficult thing I've had to do in my life. We took Ducky up on the foredeck for the afternoon, set her under a shady tarp in the cooling breeze, then gave her lots of hugs and kisses. After we said our last goodbyes, we gave her the shot. She slowly went into her final sleep with me cradling her head in my arms. At least she was with us in a friendly environment and not in some scary vet's office. After a little ceremony, we laid her to rest in the lovely bay.

For those who haven't had dogs, all this may seem silly. But it's been a very emotional time for us, and it's hard to accept that our loving companion is gone. We're trying not to be too sad by remembering all the wonderful moments we had with her. Ducky passed on at nearly 13, which is about 91 in 'human years'. So she had a long, full life for a big dog. Besides, how many labs get to adventure around the Pacific, snorkeling with family, chasing and being chased by sea lions, tackling turtles, barking at dolphins, swimming with whales, running and rolling on sandy beaches, patrolling the decks for flying fish during crossings, and protecting us from all perceived dangers?

So goodbye our beloved Ducky, The Duchess of Alamitos Bay, now resting in peace at lat 09°49.1S, long 160°51.1E.

—jen 09/15/10

## **Geja — '76 Islander 36 Andrew Vik Getting Groovy in the Med (San Francisco)**

It's time to hang up the Speedos for the winter, as my third straight summer of cruising the Med aboard *Geja* — the San Francisco-based Islander 36 that I bought sight-unseen through an '07

*'Lectronic Latitude* article — has come to an end.

As of my last report, two Swedish crewmembers and I had just completed an overnight sail from Montenegro to Orikum Marina near Vlorë in mysterious Albania. Once checked into the country — a process handled efficiently and at no charge by the Italian marina staff — we took the communal mini-bus to the



scruffy seaside town of Vlorë for our first glimpse of Albanian life. The town itself was shabby in what I consider a Mazatlan sort of way, and featured little in the way of historic architecture. Its beaches, however, stretched for miles to the south of town, and were somewhat lively until sunset. The bay is certainly beautiful, and had Albanian leaders not isolated the country from the rest of world for decades, the area might have become a worthy tourist destination.

A full day in the region seemed to be enough, so we sailed on, crossing paths with just the second sailboat in as many days. A sometimes boisterous sail south brought us to Himara, a small beach town attracting residents from the nation's capital of Tirana. It was a pleasant place, though its many relatively swanky bars were empty. Since it was still July, perhaps it was too early in the season to find a good party. In any event, the three of us were feeling a bit sick to our stomachs, despite having eaten at only the nicer restaurants.

COCOKAI



*Greg made up a bit for the loss of Ducky by landing a mahi.*

COCOKAI





GEJA

**For Vik, the highest 'wow-factor' of his third summer season in the Med was provided by Fiskardhon, Kefallinia in the Greek Isles.**

Continuing along Albania's mountainous coast, we checked out two awesome lunch anchorages, where steep cliffs backed sandy white beaches and turquoise 77 degree water. Eerily, we had both wonderful anchorages to ourselves. One such anchorage was just six miles from the tip of lively Corfu, Greece. Nonetheless, there were no other pleasure boats; just a fishing boat or two. In fact, during three days of transiting the coast of Albania, we caught glimpses of only three other sailboats. For those who don't care for the crowds of the Med, this would be the place to be — in fair weather anyway. Call me overly social, but to me being in proximity to other people is one of the big attractions of cruising.

Sarandë, just spitting distance from Greece, was our southernmost Albanian stop. It is the nicest of the large Albanian coastal towns. The bay is surrounded by bland looking residential high rises,

most of which are half-finished and where progress has stopped. Check-in was handled efficiently by an agent for 35 euros, while a berth on their clean, pleasant, and secure commercial dock cost just five euros a night. Unlike the large and scary officials in Montenegro, the folks in this port were very welcoming, perhaps appreciative of our effort to visit Albania. The waterfront hosted a lively *passaggiata* each night, though the numerous bars were again empty. Even the open-air nightclub, which could host as many as 1,000, was heavily staffed but had few paying customers.

Albania, the mysterious country near the center of the Med, was certainly worth a visit. The locals were shy, nice, and always helpful. The prices were really low, and the countryside is wonderful — as we discovered by renting a car for a day. Unfortunately, the coastal towns are architecturally uninteresting, with few monuments of any

sort. In fact, the most unique structures are the small, round concrete bunkers that dot the coast and interior. Starting in '72, the Albanian government told the citizens to spend all their free time building these odd, heavily-fortified circular huts. Over the next 20 years, an astonishing 700,000 of them were built. Alas, there are no funds to remove these reminders of the paranoid communist past.



GEJA

From Sarandë, the Greek island of Corfu was clearly visible, and onward we ventured to begin a few weeks of cruising the Greek islands of the Ionian Sea. Just an hour's sail from Albania, we encountered a lush, green coastline, busy with small private yachts of all types and vintages. The check-in process was no less cumbersome than in non-E.U. countries such as Croatia and Montenegro, requiring stops at multiple agencies. Unlike in the E.U. countries of Italy and Slovenia, where checking in a foreign boat is free, Greece charged 60 euros to enter. The Greeks are also known to inconsistently apply taxes to foreign boats that stay in the country for longer than 90 days.

Corfu town, just 15 miles from Sarandë, lacks a proper guest harbor, and its grimy public quay is rat-infested. Fortunately, Mandraki, the private yacht club, had a berth for us. And what a stunning location the club has, just below the north side of Corfu's massive town fortress. The stroll into town involved meandering through two tunnels

Over 700,000 of these lasting monuments to communist central planning and paranoia were built in Albania starting in the '70s.

Over 700,000 of these lasting monuments to communist central planning and paranoia were built in Albania starting in the '70s.



GEJA

# CHANGES

and over a footbridge to reach the heart of Corfu, a bustling university town that — thank to centuries of Venetian control — resembles Italy more than it does the rest of Greece. Corfu was the perfect weekend stop, with impressive nightlife and a convenient place to exchange the

Swedish crew for two Finns.

Given its size, Corfu actually didn't have much in the way of interesting nautical destinations, so it wasn't until we reached Paxos that the well-known nautical 'wow-factor' of Greece became apparent. Lakka, on the northern tip of Paxos, was excellent, with a huge turquoise bay and a perfectly cozy town. Further south, Gaios is an enormously popular town where little diesel and water trucks deliver their goods directly to your berth on the quay. The exposed western side of Paxos is stunning, with steep white cliffs plunging vertically into the clear sea, and there are numerous caves that can be explored in calm weather. Little Anti-Paxos, a stone's throw south from Paxos, has some spectacular beach coves — so spectacular that they seemed to attract every charter and excursion boat in the region.

**Vik has found that female crew improve morale.**

From the so-called 'Emerald Bay' on Anti-Paxos, we set sail for Parga on the mainland, just 12 miles away. About halfway across — and while we were enjoying a lively beam reach — the thundercloud to starboard that I'd been monitoring decided to 'erupt'. With the first drop in temperature and windshift, we quickly doused all sail. It was a good

**San Francisco-based 'Geja' found the calm water quays of the Ionian Sea to be just to her liking. But she also thrived in brisk winds.**

thing we did, because within minutes the sea to starboard became a frothy white, the likes of which I'd never seen before while on the water. Even with the motor running, all attempts to hold course against the wind and sloppy seas were in vain. Fortunately, we had sea room astern, and rode with the wind back to the familiar harbor in Gaios.

The following day, the Finnish girls and I made an uneventful 30-mile sail to Preveza on the mainland — though I did keep a wary eye on every cloud in the sky. Preveza has a long town quay with space for dozens of boats. Unlike in Croatia, Greece seldom fits its quays with lazy lines, which means everyone has to drop their anchor while backing up to the quay, hoping not to cross the anchor chains of other boats. With an inexperienced female crew and *Geja's* manual windlass, I was worried that we'd have problems. But pint-sized Vilja, who is a competitive fitness pole-dancer, was more than up to the task, muscling the 20 kg Bruce anchor up and down with enthusiasm.

Safely moored in Preveza, we noticed another contrast to Croatia. A similar spot in Croatia would have cost between 30 and 40 euros per night, including lazy lines, water, and electricity. While Preveza didn't have any such amenities, it cost nothing to stay the night. That's right, *nada!* *Geja* has solar panels, and I managed to connect a hose to a nearby irrigation system, so we were all set. As a result, the girls and I paid for just one mooring during the week, and that a reasonable 28 euros back at the Mandraki Harbor in Corfu. For the rest of the stay, the three of us spent a total of just 160 euros for berthing, onboard food, and fuel. A typical week in Croatia would have cost at least twice as much. No wonder few cruisers stick around Croatia for very long.

My next crew included Rob and Christine Aronen, vets of the '06 *Ha-ha* on their former boat *Nomad*. Now landlocked in Luxembourg, they are always happy to get their sailing fix on *Geja*. Along with Mari, a Swede who lives in San Francisco, we thoroughly explored the most interesting part of the Greek part of the Ionian Sea — meaning Lefkas and its surrounding islands. While the Aegean Sea of eastern Greece is known for its wind, particularly in



July and August, the Ionian is supposed to be mellow. This, however, proved to be absolutely not the case during our visit, as the wind howled. It made for great sailing, although some local knowledge would have been useful, as the winds wrap wildly around the half-dozen or so significant — and tall — islands of the region.

The more we moored in Greece, the more interesting it became. For not only does a spot on the quay cost nothing, there seem to be no rules about where one may settle in. We often found complete chaos, and crossed anchor chains were common. We saw boats Med-moor to light poles and to each other, while squeezing into impossibly narrow spots. The flotilla charter fleets have the benefit of a staff member who gets in a dinghy and directs anchor placement and takes lines to shore. Knowing how to park a boat is apparently not a requirement for chartering a boat in Greece.

Overall, the Ionian Islands of Greece

GEJA



GEJA





# IN LATITUDES

ALL PHOTOS COURTESY GEJA

as even decent restaurants don't have seats on the bowls or toilet paper. How Third World is that? A totable toilet seat would be good cruising gear in Greece. But the biggest disappointment was the lack of a party scene. Despite our being there at the highest of high season, there was simply no decent partying aside from Corfu town. For a guy like me who appreciates a good night out, this part of Greece was not the place to be during the prime summer weeks.



**Customers of the big charter boats in Greece were packed in like sardines.**

In the November *Latitude* I'll wrap up my report of my third season in the Med — during which time I returned to the east coast of Italy and to Croatia — but I'll share some basic facts now. I was on the go for 81 days with 20 different crew, and visited 50 different places in five countries. I logged 1,400 miles, covering 43% of them under sail alone. The engine was on for 200 hours. Marinas are costly in the Med, and this summer we were typically charged between 40 and 50 euros a night, with the high being 60 euros. We stayed in marinas for 26 nights, though about half of those stays were avoidable. But sometimes paying for a mooring makes crew changes much easier, and sometimes it's good to give your boat a good scrub down and/or hunker down in bad weather.

But cruising the Med doesn't have to be expensive. Avoiding marinas is the best way to save. Groceries cost somewhat more than in the U.S., although

**For Finns Heini and Vilja, Leg Four crew, the blue skies and waters of Greece were a nice change from the greys of Finland.**



GEJA



**Clockwise from lower right; Mandraki Harbor. Greek food is simple and healthful. A blue water cove of Anti-Paxos. At Gaios, the water truck comes right to your boat. These kinds of crowded conditions make it clear that 'Geja' wasn't in Albania anymore. Another view of a cove at Anti-Paxos.**

were a real treat. Fiskardhon on Kefallinia, was my favorite town harbor, while the cliff-backed day anchorage on Atokos provided the greatest wow-factor. Skorpios, Jackie Onassis' private island, was off-limits, while the "hurricane hole" at Vliho Bay near tacky Nidri was chock full of sailboats that would have fit right in with the anchored-out fleet on Sausalito's Richardson Bay.

Unlike Croatia's centuries-old buildings of limestone, Greece's earthquake-prone villages feature more modern construction and lots of color. The locals are lively and helpful, and those whose services we needed were fluent in English. The country's well-known economic problems were not noticeable to us, aside from a few conspicuously empty storefronts on main streets and a euro that cost about 20% less than in the previous two summers. Traditional restaurant

dishes such as *moussaka* could be had for about eight euros, though a couple of two-euro pitas were plenty filling. My only caution would be to watch out for the inexpensive table wine, which was bad more often than not.

There are some downsides to Greece, though minor. The stunningly scenic, steep-sided mountains we often had to anchor in 50 feet or more. Free mooring on those town quays is awesome, but without any electric connections, so you often find yourself next to boats running generators — and sometimes throughout the night. The regional transit systems are poorly designed, which caused some problems for my crew. The toilet situation is also poor,

# CHANGES

Americans should appreciate that we pay less for packaged products than pretty much anywhere in the western world. A 'proper' two-course dinner with wine starts at 25 euros, though a hearty tuna pizza and a glass of house wine go for less than 10 — and even less than that in Italy. I pay 180 euros per year for full comprehensive boat insurance — though it took an inside connection to get full coverage for a boat that's 34 years old.

Another thing some Americans take for granted is the ease with which we can acquire specialty marine products. In the U.S., thousands of specialized marine parts are available off the shelf at a nearby West Marine, and many thousands more can be obtained within days from any of hundreds of online retailers. Not so in Europe. While

there are chandleries, they are mostly independent retailers carrying limited inventory. Ordering parts from elsewhere requires that the shopkeeper order it for you — assuming that some distributor in the country even stocks it. In Italy, you can't count on the shopkeeper to speak English — or any other foreign language. On top of the ordering hassles, you can expect to pay about 50% more for marine parts in Europe. In the case of *Geja*, it's far easier and less expensive for me to carry needed parts and spares with me on the flight from the States than to try to track them down in that part of the world.

Aside from the furler meltdown that I'll report on next month, *Geja* held up

***It seems that there is no end to the beautiful Greek islands that dot the blue waters of the Ionian Sea. This little lovely is Parga.***

AZURE II



***Vilja, pole-dancer and anchor-lifter.***

GEJA



like a champ! The toolbox was hardly opened during the summer, a sure sign of a trouble-free cruise and good off-season planning. *Geja* is a sweet, stiff ride, and her U.S. flag, San Francisco hailing port, and salty looks generated a buzz at nearly every place we stopped. It was the summer of a lifetime — for a third year in a row! As always, the options for next summer are to sail or sell. Stay tuned!

— andrew 09/20/10

## **X — Santa Cruz 50 David Addleman Cruising Malaysia (Monterey)**

After spending a few years cruising Mexico with my Cal 36 *Eupsychia* — which I still have for sale — I bought a Santa Cruz 50 in Johor Bahru, Malaysia, and christened her *X*. After hauling her at Raffles Marina in nearby Singapore, I set out on my first trip — a three-day voyage to the 200-mile distant island of Pulau Tioman.

Far from the noise and smog of steaming Singapore and the hectic shipping in the vicinity of the export center, Tioman is a lush, mountainous island that makes her popular with tourists — as well as monkeys, cobras, butterflies, and other animals of the tropical rainforest. The island has a nice marina, a friendly island culture, many quiet places to anchor, and fabulous reefs for snorkeling. Not far north of the equator, the water is plenty warm. Groceries, fuel, and duty-free alcohol are all readily available. There is also a small international airport on the island, which made it easy for me to commute back to California.

Like everywhere I've been in Malaysia, the meals were very inexpensive, no matter if I was dining out or preparing them myself. Lunch and dinners usually cost \$2 or \$3, and somehow they manage to sell cans of Heineken for just 45 cents.

If I wanted to be thrifty, I would go to the open air markets, where I could buy a bag of fruit and veggies for 50 cents. Although they almost give the stuff away, the fruit and vegetables — of which I recognized about half — are of the highest quality. Malaysian beef, on the other hand, is very tough.

Pulau Tioman has a small cruiser community. Most of the cruisers are Aussies and Kiwis who



are doing a one- to two-year loop of that part of the world. They tend to favor heavy steel or ferro-cement boats. There's also a bunch of Germans and a few other European cruisers mixed in, but Americans seem to think this part of Malaysia is dangerous. The cruising culture is similar to that of Mexico in the sense that there's always a great deal of socializing going on. Since most Malaysians are Muslim, and most Aussies who aren't larrakins are pretty conservative, you don't have people drinking tequila shots out one another's belly-buttons like some cruisers do in Mexico. But it's still the same cruising lifestyle that I find so satisfying.

After a couple of months at Pulau Tioman, I sailed east across what some claim are the pirate-infested waters of the South China Sea to Borneo. There had been some official reports of attacks on shipping, and while there is much folklore of cruisers being attacked, there were no recent verifiable evidence of it

# IN LATITUDES

ALL PHOTOS COURTESY THE X-MAN



**Spread; Typical Equatorial Belt clouds as seen from the harbor at Laubaun on the island of Borneo. Insets from left: Why should David freak about pirates when there is malaria? The Rainforest World Music Festival is a big deal. In fact, even the locals put on their party hats and started squawkin'.**

that I could find. My only precaution was to swing well south of the Anambas Islands, which seemed to be the nexus of the problems for ships.

The whole piracy issue was a little worrisome to me, but I took comfort in the fact that I've got X so stripped down that I don't think any pirates would bother with her. Since I bought the boat, I've probably removed 2,000 pounds of what I considered to be excess stuff. Things like 100 pounds of paper charts, parts for boat systems that are no longer on the boat, heavy winch handles, brass clocks, and four mirrors. I only need one mirror — if that! I just leave the stuff on the dock and it disappears right away. X also has more heavy batteries than I want, so as soon as I find out which are the best, I'll get rid of the others.

Removing a ton of unneeded weight from my eight-ton 50-footer has made

a noticeable difference in performance — particularly in the weather conditions common in this part of the South China Sea. There is generally no wind at all — as one could deduce from the fact that I've done a lot of 50 and 75-mile days with a Santa Cruz 50. Mind you, this is an ultralight boat that will sail at almost five knots in just five knots of true wind.

It's true that X's sails are pretty pathetic, but still, if you look at weather charts for the Equatorial Belt, they're filled with random arrows without flags. Conditions are so docile that I haven't seen a single wave in seven months! It's like sailing on Lake Tahoe. The only time you get wind is in a squall, and then it's too much wind. Anyway, I spent five

beautiful moonlit nights sailing — except when I had to motor to keep from drifting backward into shipping lanes — the 400 miles until I dropped my hook in the Santubong River near Kuching, Sarawak, Borneo. For the record, Borneo is the third largest island in the world, with 73% of the land mass owned by Indonesia, 26% by Malaysia, and 1% by oil-rich Brunei.

There were a few cruisers when I arrived at the Santubong River, but with the approach of the Rainforest World Music Festival, the number of cruising boats

grew to 30. The festival is a famous showcase of world music performed by hundreds of musicians, and is attended by thousands of music enthusiasts. Each day began with orderly musical presentations in intimate workshops, but by the time the evening rain started falling, it had become a massive and muddy dance party. After the festival, I remained anchored in the river for a few weeks, enjoying the nearby city of Kuching, relaxing, and making friends.

Needing to find a marina where I could store X so I could return to California for a month, I continued northeast along Borneo's coast to Labuan, which has a reasonably good marina. It's about \$300 a month for my 50-footer, which I think is dirt cheap. Muslim Malaysia is supposedly so safe that you never have to lock your boat. We'll see when I return

**Many Americans would be shocked to see how 'first world' and upscale many parts of Malaysia are. Per capita income is almost \$15,000.**



**Not all the (tourist) women in Muslim Malaysia wear burqas.**



X-MAN

X-MAN

# CHANGES

this month.

Like most Malaysian cities I've visited, Labuan is surprisingly as modern and glistening as any in the world. People have nice houses and new cars, and seem affluent. It's all the oil, gas and minerals in Malaysia. Everybody is very friendly and there have been absolutely



**The Labuan Marina makes the Ala Wai look tawdry.**

no personal safety issues. Processing papers at Labuan, as in all other major ports, was easy and nearly free. The cruisers all seem to have a wonderful time, so no wonder I can't wait to get back.

So far I have been singlehanded — and loving it. I stand watch when there's wind, which isn't often, and practice guitar, cook wonderful meals, read, or just gaze at the passing world. I sleep during the frequent calms.

I've only had two equipment failures in seven months, and they were minor. The anchor windlass had a couple of failures that I should have foreseen and been able to prevent. And the refrigerator apparently had a slow leak and stopped cooling my beer. After a few hours of looking around the shops in Kuching, I found a bottle of refrigerant and the parts to fix everything.

After loading up with cheap beer in duty-free Labuan, I'm not sure where I'll go. I don't like to make plans any more than two days out, but some cruising friends in Malaysia just wrote to say they are headed to Kudat, Borneo, so I may follow them there. On the other hand, I like the idea of sailing to Palau, the former U.S. Territory 2,500 miles to the east, which is noted for spectacular World War II wreck diving. The downside of that is that it's pretty close to the typhoon zone, so we'll just have to see.

— david 09/05/10

**Malaysian veggies — as well as fruit — are delicious and inexpensive. Malaysian beef is inexpensive, too, but it's very tough.**



X-MAN

## **Niki Wiki — Gulfstar Sailmaster Terry and Jonesy Morris Medical Care Outside the U.S. (Chula Vista)**

Prior to doing the Ha-Ha four years ago, we wrote the following: "We quit our jobs, sold the house, sold the car and furniture, and got rid of all our stuff. We're now living aboard our 50-ft Gulfstar Sailmaster *Niki Wiki* about to start an open-ended cruise to Mexico, Central America, thru the Panama Canal, and into the Caribbean. We're going wherever our vagabond spirits take us."

Most recently our spirits have taken us to Guatemala, which is where we were when we read that the editor of *Latitude* was asking cruisers what they do about health insurance. The time of his request couldn't have been better, for two weeks ago I had emergency laparoscopic surgery to remove my gallbladder. The total cost was \$5,000 U.S. That included three nights and four days in the upscale and modern university hospital in Guatemala City. This cost included the surgeon, anesthesiologist, and primary care doctor fees, as well as all tests, medications, and follow-up care. It was one of my best hospital experiences, and I've had six other surgeries, all in the United States.

We have been cruising full-time for four years throughout Mexico, Central America, Panama, Colombia, and now Guatemala, without health insurance. Due to pre-existing health conditions, we are virtually uninsurable except through employer group policies — which means we'd have to work and not cruise. We made the decision to budget for unplanned medical care, and just took off cruising to live.

So far, we have been quite happy with the medical and dental services we have received. Jonesy, my husband, had an urgent and extensive root canal and crown procedure in El Salvador. It was done by an endodontist who was trained in the States. The total cost for two dentists and the crown was \$350. We have had routine teeth cleanings and check-ups for between \$25 to \$40, and filling repairs for \$25 — all by English-speaking dentists. A walk-in, same-day mammogram at a private hospital was \$35, with the typed radiologist report and films available for pick-up the next day.



Routine blood-work is done inexpensively on demand at laboratories.

Both Colombia and Guatemala advertise medical tourism, which is why people travel to these countries to get elective or other surgeries not covered by their insurance. It's done at greatly reduced prices. There are English-speaking individuals who will arrange whatever medical services you might require. Among the cruising community there are always other folks who will gladly give recommendations of doctors, dentists, and lab work. We have often relied upon this network, and have never been disappointed.

I'm recovering rapidly while lounging by the pool and playing Mexican Train dominoes. We are looking forward to leaving this hurricane hole in the Rio Dulce at 'Mario's Marina and Summer Camp for Cruisers' so that come November we can head back out to sea to explore Belize and the Bay Islands of Honduras.

— terry 09/20/10



*Inset; Terry, minus her gall bladder, and Jonesy in the Rio Dulce. Spread; Can you identify this month's 'Mystery Island'? We're stumped.*

**Sea Level — Schionning 49  
Jim and Kent Milski  
Surfing and Flipping  
(Colorado)**

To give you an idea of how cold the California coast has been this summer, Jim came back from his and Kent's cat at Vuda Point, Fiji, to surf Imperial Beach, which is just south of San Diego. "Thanks to a cold upwelling, it was 59 degrees. That's terrible!" he said.

No kidding. Especially when you've become accustomed to surfing the warm waters of Mexico and the South Pacific. "The water had to be 80 or 82 degrees in Fiji when we left," continued Jim. "It's 'no wetsuit' surfing in the tropics — although we do wear a light suit if we're going to be snorkeling for an extended period of time. Another nice thing about surfing in the South Pacific is that unlike some places in Mexico, there are no sea urchins."

The downside of surfing in French Polynesia, of course, is that you are almost always surfing the edge of a reef. "We haven't seen a sand beach since Mexico," laughs Jim. "During every session, I'll make contact with the reef a couple of times. But the good news is that the reefs are kind of flat instead of being jagged."

Like most surfers, Milski didn't want to reveal the lesser known locations he's surfed, but he says he's found good surf in the Tuamotus, and great surf in French Polynesia. One of the well-known spots he hit was Huahine. "There's one break for longboards, and another for short boards," he says. "While there, we met Liz Clark of the Santa Barbara-based Cal 40 *Swell*. What a jewel of a person. She's just wonderful!"

Jim and Kent were in Niue when Kelly Wright arrived on the ship that rescued him after *Anna*, his New Mexico-based Atlantic 57 catamaran,

flipped and had to be abandoned. "We'd seen the storm coming on the GRIB files," says Jim. "In fact, we — along with two Aussie boats and a Belgian boat — saw what was coming while we were up at Palmerston, so we rushed to Niue to grab mooring buoys. It was a good thing, because we had gusts into the mid-40s come through. We assume that the guys on *Anna* saw the GRIB files, too."

**Niue, known for rocks, not good anchoring.**

"When you get GRIB files from SailMail," Milski continued, "you can also pull one down that shows how much moisture there is in certain areas. The chart comes out shaded or black where there is lots of moisture, so you know it's a low. We could all see it. And when Wright says they were hit by over 60 knots of wind, I believe him. For there were some guys from Indiana on a boat called *Bubbles* flying a chute toward Tonga, the opposite way *Anna* was headed, and they got hit by 60 knots. Fortunately, they got the chute down in time. We later attended a weather class in Tonga, where the instructor explained that *Anna* had flipped in an area where two lows had come together."

Kent, who spoke extensively with Wright and his crewman Glen McConchie, said she was told that the cat had paused when she was heeled over about 45 degrees. "Kelly and I both gave each other that 'she's gonna come back down' look," McConchie told her, "but then she continued all the way over."

McConchie had some other advice for Kent. "Don't ever mount the EPIRB high up in the salon. Even though I was inside *Anna*, since she was flipped I had to dive down into the water mixed with

**Cruising cats have become more popular in the last 10 years. They are most popular, however, when they are right side up.**



SPREAD, COCOKAI; INSET, NIKI WIKI

DENISE DE MENCE

LATTU DENICK

# CHANGES

boat debris to try to get the EPIRB. I bet that it took me 18 dives before I was able to get it. Part of the problem is that it's very disorienting when the cat is flipped, so I spent a lot of time looking for it on the wrong side of the bulkhead."

McConchie was also able to answer the question of why he couldn't get out the escape hatch. Over the years, some escape hatches on cats have leaked or even been holed. As a result, *Anna* was built with a solid plastic window instead of a hatch. A hammer was mounted next to it so the window could be smashed in the case of an emergency. Unfortunately, the window was too strong for the blows from the hammer — as well as for blows from a fire extinguisher and anchor! So having been inside the hull for 15 hours, McConchie ultimately had to swim out a deck hatch in what had become the bottom of the flipped cat.

While the flipping of *Anna* proved that even very large cruising cats can capsize if greatly overpowered, Jim and Kent are confident their *Sea Level* won't because they are very conservative with how much sail they set. Not only did they sail from Mexico to Polynesia with two reefs in the main at all times, but they now often sail with just a headsail and no main at all.

"Having sailed *Sea Level* so many miles now, we've learned that in reasonably strong winds we sail almost as fast without the main as we do with it," says Jim. "And it's always much more comfortable with less sail. We might only do 6.5 knots instead of 7 knots, but if we get hit by a big squall, we can quickly furl the headsail or even more quickly release the sheets. I also really like the idea that *Sea Level* doesn't have the mini-keels that *Anna* had in addition to her daggerboards. It's my understanding the blast of wind blew *Anna* around until she was beam to the seas, at which point the cat tripped on her leeward mini-keel. I've

**Wayne and Carol are headed to the South Pacific after years in Mexico. They sail conservatively, so they don't fear flipping 'Cap Cat'.**



also seen cats that have a lot of control lines run through sheet-stoppers to a single winch. I don't like that. We have dedicated winches for each mainsail control line, so they can all be released instantly. Kent and I are aware that it's possible that our cat could flip, but because of how we sail, we're confident that she won't.

When back in San Diego, the Milskis stayed with Wayne Hendryx and Carol Baggerly aboard their Hughes 45 *Capricorn Cat*. "We're aware that cats have the potential to flip," says Hendryx, "which is why we are very conservative with how much sail area we carry. After buying the cat from Blair Grinols, we got hit by 35 to 45 knots of wind while sailing south off the Central Coast of California. But as we had no main up and only 25% of the genoa unfurled, the boat handled the conditions so well that we could enjoy dinner while the autopilot drove. We usually take the main down at night, and even during the day we'll often sail with one or two reefs. With cats, a couple of reefs don't slow you much."

"Blair brought *Capricorn Cat* 5,000 miles home from the Marshalls on three different occasions," continues Wayne. "He told me that he often got going to weather so fast that the cat would leap over the crests and come slamming down. His solution was to furl the genoa completely, triple-reef the main — and deploy a Gale Rider drogue from the transom — even though he was sailing to weather! It worked

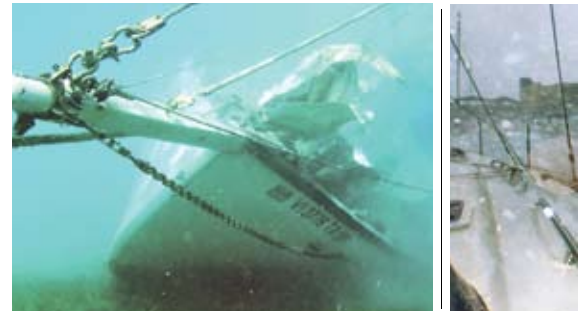

great for him."

As for the Milskis, they are delighted with the cat that Jim built from a kit. "*Sea Level* is the perfect boat for us," Jim says. "And what's really neat, is that she's always teaching us how she likes to be sailed. It makes it really fun."

Jim and Kent are also really enjoying the international group of cruisers they're meeting in the South Pacific. "There are quite a few Europeans out here," says Kent, "many of them with brand new or near-new boats. And just about all of them are equipped with first class stuff. They're good sailors, too."

"We've also run into about 10 boats that were bought in the U.S. by Aussies, Kiwis, or Europeans, and that are being sailed to New Zealand and Australia," says Jim. "The belief is that they can be sold for a big enough profit to pay for their year or two of cruising. Of course, there are still a number of very adventurous folks on smaller boats and even smaller budgets. We met one couple on an engine-less 29-footer that took 40 days to make it from the Pacific Northwest to San Francisco. You can imagine the stories they have to tell."

— latitude/rs 09/09/10

COURTESY ELVIS



# IN LATITUDES

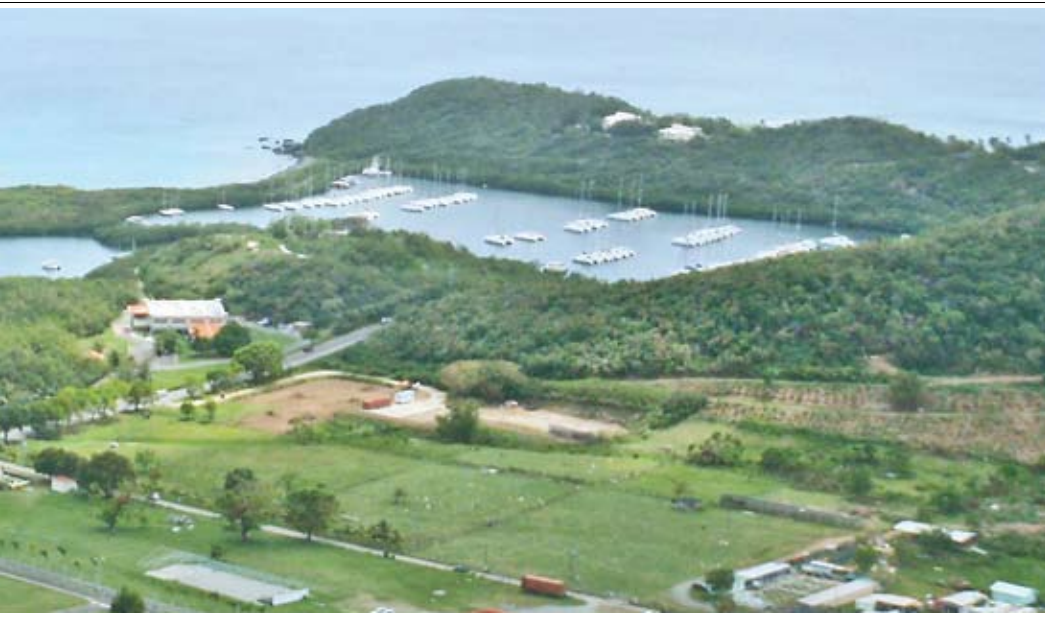

SUNKEN BOAT PHOTO BY FRANKLIN TULLOCH; ALL OTHERS BY KARL ILLACKER

**Top spread and right; Paraquita Lagoon served the charterboats well. Middle; During a lull in 'Earl'. Left; A boat on the bottom at St. John.**

## Cruise Notes:

The streak of boating interests in the northeastern **Lesser Antilles** not being hit hard by a hurricane in many years was nearly broken in late August and early September by the trickster **Earl**. He was forecast to be a mild Category 1 hurricane that would sweep to the northeast of the islands at a reasonably safe distance. Further, all the islands would be in the least dangerous southwest quadrant. But you can't trust a hurricane any more than you can trust a politician, and at the last minute *Earl* not only strengthened to a become a powerful Category 4 hurricane with winds to 125 knots, but decided not to veer as far to the northwest as he was supposed to. That meant the islands from Antigua to the U.S. Virgins got a bigger scare and were hit harder than originally expected. As he closed on the islands, *Earl* also became a much broader storm. The result was that all the boats on the south side of islands — such as Tortola in the British Virgins, the center of the bareboat charter universe — which had land

between them and the leading edge of the hurricane, ended up being lashed by the southerly winds of *Earl's* tail. Getting lashed by southerly winds from a hurricane that passes to the northeast of you in the northern hemisphere is weird, but that's what can happen if the hurricane covers a large enough area. The following is an eye-witness report from a frequent *Latitude* contributor — who doesn't want his name used because he doesn't want his insurance company to know his boat was in the British Virgins and not 400 miles to the south at Grenada, and outside the hurricane zone:

"My boat and I were at Village Cay Marina on the south side of **Tortola** near The Moorings base. *Earl* started with winds from the northwest at 45 to 48 knots, but as we had the tall island between him and us, and no fetch, it wasn't bad. But by 10 p.m., the wind had backed 90 to 100 degrees and was coming out of the south at 70 knots! Everyone who had secured their boat for northwest winds scrambled to adjust their lines for winds from the south. The two sets of wind instruments atop my 70-ft mast read a constant 74-78 knots from the south for three hours during the

worst of it, with a high gust of 86 knots. I'd removed everything I could from the outside of my boat, and had her secured by 12 strong lines. While Tortola suffered lots of downed trees and power lines, and there was no electricity or lighting at night, my boat wasn't damaged. In fact, there was no damage to any of the 25 other boats in the marina. However, many of the boats anchored or moored out — and even commercial vessels including inter-island ferries — were badly damaged."

It was odd how *Earl's* tail had done most of the damage, and the pattern of destruction was equally unusual. Some boats were lost at **St. Barth** — where boatowners had been told to expect only 40 knots — and a big sailing vessel was lost at **St. Kitts**. On the other hand, we got few reports of damage at the huge sailing center of **St. Martin**, and the folks at the yard in Spanishtown on **Virgin Gorda** said they didn't have any boats blow over. Thanks to the great hurricane hole at **Paraquita Lagoon** on the south side of Tortola, the Sunsail and The Moorings charter yachts did fine, as did our Leopard 45 cat **'ti Profligate** and the other boats in the BVI Yacht Charters fleet. Indeed, just two days after *Earl* passed, *'ti* went out on charter. The boats at Tortola's West End/Soper's Hole, on the other hand, were hit pretty hard because they had no protection from the northwesterly winds coming from the leading edge of *Earl*.

Tom Larson, who did the Ha-Ha in '05 with his wife Amy aboard their Tiburon-based Yorktown 35 **Sandpiper**, then nearly circumnavigated, reports that there was quite a bit of damage to boats on the exposed south side of St. John in the U.S. Virgins. "*Earl* took out all 10 boats at Chocolate Hole, four boats at Cruz Bay, and several others in Coral Bay — even though we only got sustained winds of about 40 knots and gusts up to

**'Earl' surprised everyone by suddenly becoming so well-defined. The breadth of the storm brought southerly winds to many islands.**

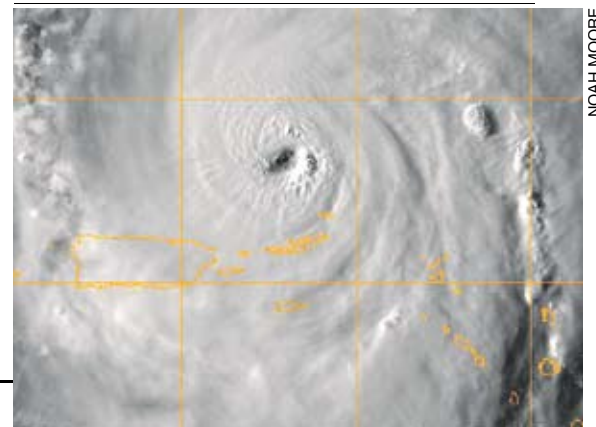

NOAH MOORE

# CHANGES

60 knots.”

The bottom line is that *Earl* could have been a much more destructive storm. So the Eastern Caribbean’s streak of good luck continues. But keep your fingers crossed, because hurricane season doesn’t end there until December 1.

To prove once again how quickly and abruptly cruisers change their plans, Tom and Amy Larsen spent nine months in Australia before deciding to sail *Sandpaper* up the Red Sea and then cross the Atlantic. They stopped in St. John in the Caribbean to visit some friends, expecting to continue on up to Charleston, South Carolina, to look for work. But while they were having a “few rums” the night before they were to leave, the charter trawler *Sadie Sea* pulled up to the waterfront bar where they were drinking. To make a long story short, they bought the trawler and sold *Sandpaper*, and are now in the charter trade in the Virgins.

While all of Mexico’s strong hurricanes have stayed offshore so far this summer, that’s not to say that the **Vallarta Coast** didn’t get clobbered by Mother Nature. According to John and Gilly Foy of the



DICK MARKIE DISASTER PHOTOS

**When the bridge for the main highway over the Rio Ameca collapsed, this boy finally had an acceptable excuse for being late to school.**

Alameda and La Cruz-based Catalina 42 **Destiny**, it rained over 13 inches in one night! Sure, summer is the rainy season on the Mexican mainland, but that was a month’s worth of rain in less

than 24 hours. The result was that a 150-ft section of the northbound two-lane bridge between Puerto Vallarta and Nuevo Vallarta collapsed in the middle of the night. With the separate southbound bridge carrying Highway 200 traffic having to be closed to check for damage, the tens of thousands of people to the north of the river, as well as all the supplies coming from Guadalajara, didn’t have a way across or around the raging river. So people who absolutely had to get to the other side of the river gathered in the parking lot in front of the Vallarta YC at Nuevo Vallarta, and were eventually transported to Marina Vallarta and the downtown area by an armada of 150 boats of every size, shape and description. Farther up the Vallarta Coast, the popular surfing/tourist town of **Sayulita** was completely cut off after its connecting bridge to the main road collapsed. Mexico being Mexico, roads were quickly cleared and ways were found to get people and goods where they needed to go. By the time anyone in the Ha-Ha fleet makes it to the Vallarta



## INSURING YACHTS FOR OVER 50 YEARS

Providing Cruisers and Racers All Over the World  
with Prompt, Reliable Service since 1959

Contact Us for a Quote



Exclusive  
**MARINERS Odyssey®** Program

- Mexico
- South America
- South Pacific
- Caribbean
- Mediterranean

**Racing Sailboat Program**

- TransPac
- Pacific Cup
- PV / Cabo Races
- Caribbean Regattas

[www.marinersins.com](http://www.marinersins.com)

**QUALITY COVERAGE AVAILABLE IN MEXICO**

Mariners Insurance Mexico offers insurance programs for health, homes, autos, motorcycles and yachts in Mexico.

[www.marinersmexico.com](http://www.marinersmexico.com)

Corporate Office: 206 Riverside Ave., Suite A, Newport Beach, CA 92663 / Ins. Lic. #0D36887

Seattle  
800-823-2798

N. California  
boomeins@aol.com  
800-853-6504

L.A./Orange Co.  
800-992-4443

San Diego  
800-639-0002

Official Sponsor  
**2010  
BAJA  
HA-HA**

Puerto Vallarta  
52-322-297-6440

East Coast  
Bradenton, FL  
800-914-9928



area in mid-November, the rainy season will have ended, and we're confident the major problems will have been sorted out. As for the jungle along the Vallarta Coast, it said to be growing like never before. It's going to be something to see before mid-November, when the end of the rainy season and the drop in humidity naturally trim it back.

"We motorsailed our family's nomadic 97-ft brigantine **Talofa** on a Baja Bash last month after five great years in the Sea of Cortez," write Beau, Lianne and Clint Bryan. "We departed Cabo San Lucas on July 7 into the usual 30+ knots off Cabo Falso, but from then on the wind and seas progressively eased off, allowing our group of eight adults, a two-year-old, and two dogs to really begin to enjoy ourselves. We caught a large yellowtail and eight Pacific bonito. Peter Domeq, our midnight watch captain — who is also founder of San Jose del Cabo's cultural/community center Raices & Brazos, and its in-house restaurant Sabor de Amor — prepared delicious sashimi platters and many other gourmet pescatarian

meals. We anchored at both Bahia Santa Maria and San Juanico to surf a small south swell. On July 19, a dozen days out of Cabo, **Talofa** eased into her slip in Channel Islands Harbor in Oxnard. From now until the October 24 start of Ha-Ha XVII — we had so much fun we've got to do it again — we'll be taking groups of six passengers on multi-day sails to the Channel Islands. In addition, we'll be showing up for **Buccaneer Day** at Two Harbors, Catalina, on October 2. We had a piratical time at Buccaneer Day in '05, so we'll be bringing extra black powder this year. So ye boarders, beware!"

Once you get a taste of the warm waters of Mexico, it's hard to stay in chilly California, isn't it?



**Uninhibited pirates, saucy wenches with pistols, Buffalo Milks all along the bar — it's a recipe for . . . well, you never can tell.**

"Our experiences with health services in Mexico are very much in line with what you reported in the September 20 'Lectronic,'" writes Jimmie Zinn of the Point Richmond-based Morgan 38 **Dry Martini**. "On three separate occasions we encountered competent care, modern facilities, great service, and very reason-

## Your Boatyard in the Heart of Paradise



Large, fenced, secure dry storage area

**Tahiti Customs policy has changed!**  
Foreign Flag vessels can stay on dry storage in our yard for up to 12 months out of 24.

### Our Services |

#### HAULOUT

- Marine Travelift 25 tons
- Marine railway 120 tons
- Storage in adjustable steel cradles
- Fenced Yard

#### PAINTING

- Topsides, hull, bottom, varnish
- Brush, roller, spray

#### MECHANICAL WORK

- Inboard, outboard, diesel, gas
- All brands

#### REPAIRS

- Electrical repairs
- Refrigeration installation & repair
- Fiberglass & woodwork
- Welding, steel, stainless, aluminum

#### SAIL LOFT

- Sail repairs, biminis, dodgers, covers

#### STORE

- International, Pettit, Epiglass, Devoe
- Spares
- Fill U.S. gas cylinders

#### DO-IT-YOURSELFERS WELCOME!

BoatUS Cooperating Marina



Professional boatyard in the heart of Paradise



A Subsidiary of  
The Moorings Yacht Charter, Ltd.

Raiatea Carenage will make sure  
paradise is everything you expected.

Call, write, or sail in . . . we're here to serve you.

B.P. 1111 Uturoa Raiatea 98 735 Polynésie Française

Tel: (689) 600-545 ~ Fax: (689) 600-546 ~ VHF 68

Web site: <http://www.raiatea.com/carenage> ~ email: [raiateacarenage@mail.pf](mailto:raiateacarenage@mail.pf)

# CHANGES

able cost. However, we did have one negative incident that justifies a word of caution. While in La Paz, Jane and I went for dental hygiene appointments with a local dentist who had been highly recommended by some of the stationary cruisers in La Paz. Jane saw the woman on Tuesday, and I was scheduled for Thursday. When Jane returned from her appointment, she reported being surprised to learn she had three loose fillings that would need to be replaced. But the red flag went up when, during my Thursday appointment, I was told that I had three loose fillings, too. What a coincidence! Jane naturally cancelled her appointment. While taking care of business back home eight weeks later, I paid a visit to my dentist of 30 years. He advised me that my three loose fillings had miraculously tightened back up by themselves! Although I don't like telling a story like this because it's certainly not typical of Mexico, I think it's important that people know about such experiences. In nearly four years of cruising in Mexico, this was one of only two slightly troubling experiences we had."

We're big believers in the truth be-



LATITUDE/NICK

**"I have some very good news for you, senorita. The cause of your discomfort is a loose tooth. No, really, I'm not making this up."**

ing told, Jimmie, so we're glad that you shared your and Jane's less-than-satisfactory dental experience. It reminds us that a dentist popular with cruisers in Puerto Vallarta was accused of some-

thing similar. Like you, we think these are isolated instances. The good thing is that ultra low prices in Mexico mean that it doesn't cost much to get a second opinion. And because the cruiser community is so tight, such scoundrels are quickly exposed. Open wide!

By the way, after reading the report that Terry Morris of the Gulfstar Sailmaster 50 **Niki Wiki** had a very satisfactory laparoscopic surgery to remove her gall bladder in Guatemala at a price of \$5,000 for everything, a *Latitude* staffer was stunned. Her partner had had the same operation at Marin General in Marin County, and the bill came to \$80,000.

**Two "hot girls" looking for a killer** to sail with them as crew. In order to prove once again that truth is stranger than fiction, we present the following 'Crew Wanted' ad that appeared on Craigslist:

"This is a chance of a lifetime! My best girlfriend and I are planning to come into some money soon. We plan on living the dream, buying a large sailboat and just traveling around the world. Although

You're invited to...



# Drop Anchor

at the Pittsburg Marina!



**(925) 439-4958**  
[www.pittsburgmarina.com](http://www.pittsburgmarina.com)  
 51 Marina Blvd. ~ Suite E  
 Pittsburg, CA 94565

- NEW GUEST DOCKS
- NEW FUEL DOCKS
- Valvtect Marine Fuels
- Saturday Farmer's Market in the summer
- Delta Discovery Cruises
- Delta View Golf Course
- Many nearby restaurants

OFFICIAL SPONSOR



quite adventurous, we are only two small young girls, thus quite defenseless. Well, we could theoretically defend ourselves, but we will most likely be drunk most of the time and thus not in the right state to be on the lookout for pirates or rapists. I'm not sure I would be very good shooting a pirate with double vision. I tried going to the gun range, while hammered, to practice, but for some reason they would not rent me a gun. I tried explaining my fear of pirates, but that just got me physically carried out. Apparently yelling, 'But how will I fight the pirates? They could come at any moment!' caused some sort of distrust between me the gun range man. Personally, I think he must have been on some sort of power trip. Anyway, all we need is one strong, fearless man to kill any pirates we come across. If you have killed a man before, that could be a plus. If you have any pirate-killing experience, you are a definite shoo-in. You may be the luckiest man you know and the envy of all your friends. You will be able to travel the world, lie in the sun all day with two hot girls, and explore a different city every week without a care

in the world — except pirates. I cannot stress this enough. We may from time to time ask you to help fish or man the sails, but your main concern and number one enemy is pirates. Also, if you are anything like Kurt Russell in *Captain Ron*, we encourage you to apply."

"The **Reef Shipping** supply ship arrived in Niue today, and upside-down on deck was the Atlantic 57 catamaran **Anna** that had flipped on her way to Tonga in August," report Bruce and Alene Balan of the Northern California-based Cross 45 trimaran **Migration**. "We don't know the cat's final destination, but it's very sad because she was a beautiful boat when upright the last two times we saw her — which was at the boatyard in Whangarei, New Zealand, in February, when we were hauled, and



MIGRATION

**The Atlantic 57 catamaran 'Anna', daggerboards pointing to the sky, leaves Niue as deck cargo presumably bound for New Zealand.**

then again in Lifuka, Tonga, a few days before she departed for Niue."

"As for ourselves," the couple continue, "we arrived Niue last week after sailing upwind from Tonga. We just had to return to Niue, as we really love this island. We missed the whales here last year because we didn't arrive until Oc-

## Welcome Baja Ha-Ha Cruisers...

To the three best Marinas in Southern California!

Whether you're heading north or south or simply want to find somewhere to stay for a while, our marinas...

**Ventura West Marina, Dana West Marina and Harbor Island West Marina** are the places to stay for convenience, comfort and friendliness.



Ventura West Marina  
805.644.8266  
1198 Navigator Drive  
Ventura CA 92001  
[www.venturawestmarina.com](http://www.venturawestmarina.com)

Dana West Marina  
949.493.6222  
24500 Dana Pt Harbor Dr  
Dana Point CA 92629  
[www.danawestmarina.com](http://www.danawestmarina.com)

Harbor Island West Marina  
619.291.6440  
2040 Harbor Island Drive  
San Diego CA 92101  
[www.harborislandwest.com](http://www.harborislandwest.com)

# CHANGES

tober. There haven't been many whales yet this year, but it might all change, as three whales came through the mooring field this morning. We instantly grabbed our masks and jumped in, and had a wonderful 15-minute swim with them. The water was crystal clear, and between trips to the surface to breathe, the whales just floated calmly beneath us. Awesome!"

**Convergence**, the cat ketch-rigged Wylie 65 with freestanding masts owned by West Marine founder Randy Repass and his wife Sally-Christine, was first to finish in the Sail Indonesia Rally that started from Darwin in late August. According to the ever-more legendary Commodore Tompkins of the Mill Valley-based Wylie 38+ **Flashgirl**, who was along as crew with his wife Nancy, "The 550-mile event to Banda was billed as a race, but was so low-intensity as to be more of a cruise. There were several 50-ft catamarans with us, but it was all downwind in moderate breezes, allowing *Convergence* to average just under 10 knots."

Nancy had a more feminine take on



NANCY POTTER

*The residents of Banda were happy to put out a big welcome for Randy, Sally-Christine, Commodore, Nancy, and the rest of the fleet.*

the event. "It was a bit confusing because there were at least four events within Sail Indonesia starting at the same time: 1) Race to Banda, 2) Race to Ambon, 3) Rally to Banda, and 4) Rally to Kupang.

*Convergence* was entered in the race to Banda along with 10 other boats. The sailing instructions had such a short time limit that only three boats finished in time. It was a bit lumpy crossing the Arafura Sea, but the seas smoothed out nicely once we got inside the island group. When we arrived in Banda — one of the famous 'spice islands' of old, where nutmeg was discovered — the locals made quite a fuss over us. It turns out that Indonesia has invested some serious money in promoting sailing and tourism, and we were the beneficiaries."

Currently in the process of touring Bali, Java, Borneo and Sulawesi, Commodore and Nancy will soon return to *Flashgirl* in Queensland, Australia, and resume their cruise north inside the Great Barrier Reef. As for *Convergence*, we presume she's continuing on her way through Indonesia toward Malaysia and Thailand. As we mentioned in a previous *Cruise Notes*, quite a number of Ha-Ha vets were among the 120 or so boats signed up for one of the Sail Indonesia fleets. Sail Indonesia is

## Ventura Harbor Boatyard

A First Class Full Service Facility

(805) 654-1433

Official Sponsor  
2010  
BAJA  
HA-HA



S/V Talofa

Two Travelifts ~ Haul Outs to 160 Tons  
Experienced Staff \* Competitive Rates

"Do-It-Yourselfers Welcome"

1415 Spinnaker Drive, Ventura, CA 93001

www.vhby.com

## ENSENADA'S ONLY RESORT MARINA

**\$12.60 PER FOOT**

SHUTTLE SERVICE TO USA! AVAILABLE

Enjoy our 2 month special rate that includes, live aboard, access to our amenities, complimentary weekly shuttle to town, WIFI & Cable T.V. service included. Plus get a preferred discount on clearance assistance with Customs. Only fuel dock in Ensenada | Pets are welcome

OFFER EXPIRES ON NOVEMBER 30, 2010. RESERVATION CODE: CRUISERS 2010  
Rates shown are in USD. Additional taxes/fees or restrictions may apply.

FOLLOW US IN:  
f t

HOTEL CORAL AND MARINA

1 (866) 302-0066 | VHF 71  
marina@hotelcoral.com  
www.hotelcoral.com

noted for not being the most organized event, so it's still unclear which of these boats started and how they might have finished.

"We're slowly bringing our Island Packet 370 **Kwanesum** back to the Bay Area, having left Virginia in September of '08," report Ellen and Randy Hasseness. "Our boat is currently under the watchful eye of Tim at Land Sea Marina in Golfito, Costa Rica, as we're back in the States taking a break from hurricane season to visit family and friends. Come October, we'll head northwest to Mexico and ultimately San Francisco Bay. As you can tell, we don't move too quickly, but we've had wonderful adventures. Like the Wanderer, we saw 36-year-old Russian Andre Melnichenko's futuristic-looking 396-ft mega motoryacht **A** in St. Barth. After a wonderful trip down the Leewards and Windwards, and stops at Bonaire, Curacao, Cartagena and the San Blas Islands, we transited the Canal. When heading to Flamenco Marina to fuel up for our trip to Costa Rica, we saw **A** anchored there, too. What we're

really hoping to see is the Ha-Ha group off the coast of Baja in early November. We'll be going in the 'wrong' direction, but what the heck. While there is still lots for us to see, we can't wait to sail beneath the Golden Gate Bridge, flying the flags of all the countries we've visited. We'll definitely have big grins on our faces as we cover the last few miles to our new 'boat home' at the Oakland YC. Rum at 5 o'clock!"

Think what you may of Swiss **Ernesto Bertarelli's** stewardship of the America's Cup, but he has stepped up when it comes to helping protect the **Chagos Archipelago** in the middle of the Indian Ocean. Administered by Great Britain as a British Indian Ocean Territory, the Chagos group lies 300 miles south of the Maldives, and is at roughly the midpoint



*The Chagos Archipelago in the Indian Ocean, one of the most pristine marine environments left, and a favorite of adventurous cruisers.*

between Sri Lanka and Madagascar. It's comprised of seven atolls that contain more than 60 islands. The remote Chagos is regarded as having some of the cleanest waters and healthiest reef systems in the world. It's also considered to be one of the greatest cruising destinations in the world. 'Mr. Alinghi' offered more than \$5 million to support the region's newly designated Marine Protected

New Member  
Showers and  
Laundry Facilities  
Now Open!

NEW SLIPS!

Now taking reservations  
for 40' to 60'

# Emeryville Marina

ON THE BAY

When you call Emeryville Marina Home...  
...call this your backyard!

Free Wi-Fi  
and Video  
Surveillance

Slips from 20-65 ft  
Full Amenities - including  
Fuel Dock & Pumpout Station

(510) 654-3716

www.emeryvillemarina.com

# CHANGES

Area (MPA), which covers a quarter million square miles of ocean surrounding the archipelago, and includes blanket restrictions on commercial fishing.

There has been no checking out for Steve Schmidt of the Caribbean-based custom cruising Santa Cruz 70 **Hotel California, Too**. It must be more than a decade ago that he and his then-wife Barbara, who had been living in Saratoga, sailed to the Caribbean aboard one of the more basic ultralight cruising boats ever. After a few years of cruising, Barbara decided to return to the 'real world' in Santa Barbara, first living on land and now on another sailboat. Steve, on the other hand, has continued to race and cruise in the sunny Caribbee. We'd last seen him in Antigua in '05, so we didn't even recognize each other when we crossed paths in the marina in Santa Barbara in September. He reports that even after all this time, he's still passionate about sailing in the Caribbean and racing, both on his SC70 and on other big boats. Steve spends eight or nine months a year in the Caribbean, then about three or four months in the Santa

Barbara area where he has family and loved ones.

"Hola! I just wanted to alert everyone headed south to the fact that the sea lions that deserted Pier 39 a while back seem to have taken up residence here in Ensenada," reports **Harry Hanssen**. "There are about 300 to 400 of them. While tourists are sold food to feed the sea lions at Pier 39, feeding them in Ensenada can get you arrested!"

We doubt the **sea lions** in Ensenada are the same as those at Pier 39, but sea lions are a problem nonetheless. They pile on boats in such numbers that they've sunk even large ones, their endless barking can make sleep almost impossible for those on boats and in waterfront homes — and they are inattentive when operating motor vessels. As the *L.A. Times* reported last July, two Orange County sheriff's deputies had a problem when they lured a sea lion — who had been nipping at people on a dock — onto their boat for release

away from humans. While the deputies were in the boat's main control area, the sea lion snuck over to the foul-weather station, which has a secondary steering wheel and set of controls. Before the deputies knew it, the patrol boat's emergency lights, deck lights and various other equipment began going off and on, and the boat "seemed to be steering itself." Upon investigation, the sea lion was found sitting in the operator's seat, randomly flipping switches. A helm hog, the sea lion tried to bite the deputies when they tried to displace him. In full compliance with the terms of the Marine Mammal Act, the sea lion was chased away with water from a hose.

More bad luck. After suffering a severe break when his leg got caught on a wildly flapping genoa sheet, Greg Dorland of the Tahoe-based Catana 52 **Escapade** reports that his boat was hit by lightning while in Annapolis. It's not clear when Dorland's leg and/or *Escapade* will be ready to cruise again. If you're one of the ones about to begin a season or more of cruising, count your blessings, be safe — and don't forget to write!

Come to Mexico and repair your boat at

# OPEQUIMAR

MARINE CENTER CENTRO MARINO

Puerto Vallarta



88-ton (max) Travelift!  
Length to 100'  
Width to 23'

México AEROTRON RIVIERA NAYARIT PUERTO VALLARTA

www.aerotron.com El Paraíso del Pacífico Mexicano Where Mexico Comes to Life

www.opequimar.com

fuel dock • full service boatyard • brokerage • 88-ton Travelift

Your secret paradise...

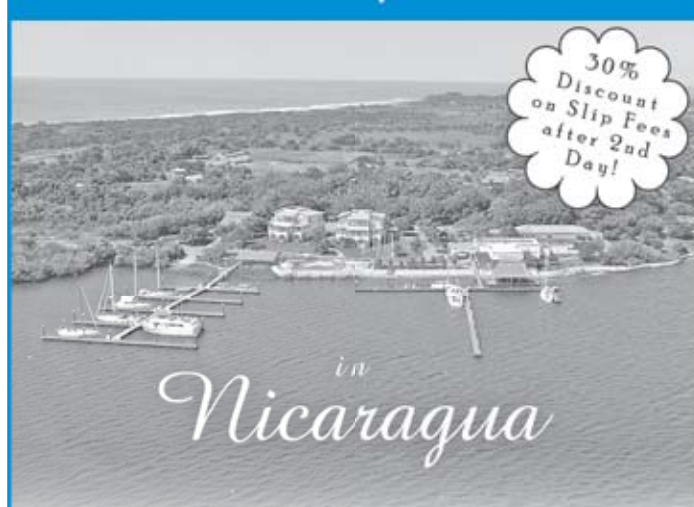

30% Discount on Slip Fees after 2nd Day!

in Nicaragua

Located in a beautiful sheltered lagoon on the north Pacific coast of Nicaragua, Marina Puesta del Sol is your premier cruising destination in Central America.



Marina Puesta del Sol  
RESORT

Aserradores, Nicaragua ♦ 011 (from US and Canada) 505-8880-0019  
info@marinaps.com ♦ www.marinapuestadelisol.com ♦ USA 408-588-0017

# It's Beautiful, It's Private, It's Home



Making boating easier – and more fun! – is what Oyster Cove is all about. That's why we rate number one with many Bay Area boaters. Oyster Cove is an exclusive yet reasonable facility of 219 berths, accommodating pleasurecraft in slips up to 60-ft long. **Oyster Cove is the private Peninsula marina closest to bluewater boating.** No other private Peninsula marina is better situated or offers nicer, fresher surroundings.

## OYSTER COVE MARINA

385 OYSTER POINT BOULEVARD #8A,  
SOUTH SAN FRANCISCO

**(650) 952-5540**

- Berths 30 feet to 60 feet
- Double Finger Concrete Slips
- Five Minutes from SFO
- Heated Dressing Rooms & Showers
- Laundry Room
- Nightly Security Patrol
- Complimentary Ice
- End Ties Available at \$5.95/Ft!

[www.oystercovemarina.net](http://www.oystercovemarina.net)

### HAWAII

## LONG TERM DRY STORAGE

*Clear Customs at our dock*

## GENTRY'S KONA MARINA

HONOKOHAU HARBOR

156°1'30" W  
19°40'20" N

TOLL FREE **888-458-7896**

[www.gentryskonamarina.com](http://www.gentryskonamarina.com)

The friendliest boatyard in Hawaii

[weatherguy.com](http://www.weatherguy.com)

## Worldwide Marine Forecasts Cruising, Racing & Commercial

Packages Starting at \$65.00 USD

(866) 882-WXGY (9949) toll free  
(808) 291-WXGY (Mobile)  
(808) 254-2525 (Office)  
(808) 443-0889 (Fax)



970 N Kalaheo Ave  
Suite C-104  
Kailua, Hawaii 96734  
[info@weatherguy.com](mailto:info@weatherguy.com)

[www.weatherguy.com](http://www.weatherguy.com)

## CZZ ZARAGOZA MARINE

*You always be safe with Us, over fifty years serving you*

Find AB INFLATABLES  
only with Us in Zaragoza Mexico.



## CZZ ZARAGOZA MARINE

AUTHORIZED DISTRIBUTOR OF:



### CONTACT:

2926 Francisco Medina Ascencio, Puerto Vallarta, Jalisco, México.  
Phone number: (322) 22 6 32 32 - [info@zaragoza.com.mx](mailto:info@zaragoza.com.mx) - ID: 62°13'8284  
Web page: [www.zaragoza.com.mx](http://www.zaragoza.com.mx) We ship to all Mexico.  
Follow us on <http://facebook.com/zaragozamarine> and <http://twitter.com/zaragozamarine>

Please read before submitting ad

# Classy CLASSIFIEDS

## Here's What To Do:

**Write your ad.** Indicate category. Remember price and contact info. We make final placement determination.

**Count the words.** Anything with a space before and after counts as one word. We will spell-check, abbreviate, edit, as necessary.

**Mail your ad** with check or money order, deliver to our office; **OR, for the best - and most exposure - of your classified ad...**

**Submit your ad safely online** with Visa, MasterCard or AmEx at: **www.latitude38.com**

Ad will be posted online within two business days, appear in the next issue of the magazine, and remain online until the following issue is released.

## PERSONAL ADS

1-40 Words.....\$40  
41-80 Words.....\$65  
81-120 Words....\$90  
Photo.....\$30

• Personal Advertising Only •  
No business or promo ads except Non-Profit, Job Op, Business Op

**'Trying to Locate' Ads** are for those searching for lost boats/people - not shopping - and cost **\$10 for 20 words max**

**FREE Online Ads** are for a private party selling a boat for less than \$1,000 - or gear totalling under \$1,000. (One per person; must list prices in ad.)

All ads will be set to fit *Latitude 38* standard • Re-Run Ads: Same price, same deadline

## BUSINESS ADS

**\$70 for 40 Words Max**

• All promotional advertising •  
1 boat per broker per issue  
Logo OK, but no photos/reversals  
No extra bold type • Max: 12 pt font  
Artwork subject to editor approval.  
Biz ads will not appear on website.

## DEADLINE

is **ALWAYS** the **18th at 5 pm**

for ad to appear in the next issue.

*Due to our short lead time, deadlines are very strict and include weekends & holidays.*

**Sorry, but...**

- No ads accepted by phone
- No ads without payments
- No billing arrangements
- No verification of receipt
- We reserve the right to refuse poor quality photos or illegible ads.

*Latitude 38* 15 Locust Ave, Mill Valley, CA 94941 Questions? (415) 383-8200, ext 104 • class@latitude38.com

**WHAT'S IN A DEADLINE?** Our Classified Deadline has always been the 18th of the month, and it's still pretty much a brick wall if you want to get your ad into the magazine. But it's not so important anymore when it comes to getting exposure for your ad. With our new system, your ad gets posted to our website within a day or so of submission. Then it appears in the next issue of the magazine. So you're much better off if you submit or renew your ad early in the month. **That way your ad begins to work for you immediately.** There's no reason to wait for the last minute.

## DINGHIES, LIFERAFTS AND ROWBOATS

**11-FT AMI AC-330, 2006.** Alameda. \$1,600/obo. Inflatable, grey, easy planing catamaran design, max 20hp removable floor boards. Good condition, used only 7 months, purchased brand new 11/08, all details on website: [www.amiboats.com/boats/advanced.html](http://www.amiboats.com/boats/advanced.html). **MUST SELL.** (530) 277-8155 or cattmarine@gmail.com.

**TWO BOATS, ALAMEDA, CA.** \$2,500 and \$675. 16-ft traditional dory. Oak, cedar, copper rivets, bronze screws, no ply, no glass. 2 pair varnished oars, sewn leathers (motor well). Excellent condition; \$2,500. 8'4" glass dinghy with oars. Better than new. Holds 4, plus small motor; \$675. (510) 830-7982.

**10-FT ACHILLES INFLATABLE, 2001.** Stockton, California. \$2,500. With 2001 4-stroke 9.9 Honda. Less than 20 hours on both. (520) 850-7761 or namaste\_crew@yahoo.com.

**BOLGER 'DINGHY' CARTOPPER 11' 6".** \$1,450/obo. Spirit sail, row or small outboard. Fiberglass over marine plywood. New condition. (530) 865-7532.

## 24 FEET & UNDER



**14-FT SWALLOW, 2009.** Santa Barbara. \$4,500. Andrew Wolstenholme design from England, professionally built in Washington State 2009, plywood and epoxy clinker construction. Gaff main, Harken roller furling jib, rigged for single-handed sailing, paddle and yoleh, cover. Complete with King road trailer and spare tires. Owner reluctantly selling for health reasons. Based in Santa Barbara. A unique and ideal family boat, which is great fun to sail. [venbed@gmail.com](mailto:venbed@gmail.com).

**24-FT MELGES.** Alameda Boatyard. \$20,000. Hull #14. Race ready. Full boat covers. Contact Frank. (512) 750-5735 or [cabosportsfrank@yahoo.com](mailto:cabosportsfrank@yahoo.com).

**22-FT CATALINA, 1981.** Davis, CA. \$1,950/obo. Swing-keel 15hp self-starting Tohatsu (just tuned). Dual batteries, Pop-Top w/curtain, 4 sails, trailer, owner disabled, some neglect. Fresh-water boat. On trailer. Best offer \$1,650-1,950. (530) 756-0874.

**19-FT WEST WIGHT POTTER, 2001.** Folsom Marina #B37. \$9,500. Complete package, including trailer with extension hitch, sails, sail covers, stove, Porta-Potti, cushions, 4-stroke 5hp Nissan motor, etc. Sleeps 4. Contact for complete details. (916) 409-0988 or [bhuth@wavecable.com](mailto:bhuth@wavecable.com).



**20-FT 'NESS' SHETLAND SAILBOAT.** 2006. Sebastopol. Best offer. Handbuilt sailboat with 22' Magic Trail trailer. Balanced lug or gaff sail rig with motor well and 2.5hp 4-stroke Yamaha motor. Mahogany lapstrake epoxy resin construction. 4-6 capacity. (707) 829-8405 or [jstamp@sbcglobal.net](mailto:jstamp@sbcglobal.net).



**21-FT SEAPEARL, 1986.** Tempe, AZ. \$6,000/obo. SeaPearl "ketch cat" sailboat with teak/mahogany deck, galvanized trailer, dual ballast, centerboard, antifoul paint, cushions, motormount, cover, center and captain's seat. This is a fun boat! [www.marine-concepts.com](http://www.marine-concepts.com). Contact Kevin (602) 821-0284, (480) 759-0318 or [k-mart@cox.net](mailto:k-mart@cox.net).

**24-FT COLUMBIA CHALLENGER, 1964.** Stockton. \$3,500/obo. Price slashed \$1,000 for quick sale. Proven racer, new self-tacking/working jibs, swell main, crunchy spinnaker, smooth bottom, sink w/ice chest, pulpits, tabernacle mast, clean, rigged, sail ready. Newer trailer included. (209) 476-1381 or [phil.hendrix@excite.com](mailto:phil.hendrix@excite.com).

**16-FT SAILING DORY, 2006.** Napa, CA. \$5,600. Glued lapstrake meranti plywood construction, white oak gunwales, mahogany seats and interior finished bright. Sails great with spritsail, centerboard and rudder mounted on wineglass stern. A real attention getter. Price includes boat with sailing gear, oars, trailer and custom cover. 2hp Honda available if desired. (707) 265-8415 or [roormann@vom.com](mailto:roormann@vom.com).

Yacht Repair  
Design / Consulting  
Custom Interiors  
Exterior Joinery



## STEVE'S MARINE WOODWORK

60 C Libertyship Way, Sausalito  
[jonessail@aol.com](mailto:jonessail@aol.com) • (415) 332-2500

## N.E. MARINE TITLE

Coast Guard documentation • Title/lien searches • Transfers • Mortgage filing • Escrow services  
Local closing facility for brokers or private transactions  
30 year experience of doing it right the first time

1150 Ballena Blvd, Alameda, CA • (510) 521-4925



## NOR-CAL COMPASS

Adjustment • Sales

Authorized Compass Repair

Hal McCormack • [norcal.compass@verizon.net](mailto:norcal.compass@verizon.net) • Phone/Fax (415) 892-7177

## BOAT • LETTERING

[alphaboatsue@aol.com](mailto:alphaboatsue@aol.com) • (510) 599-1197 • [www.alphaboatgraphics.com](http://www.alphaboatgraphics.com)

Creative and durable lettering and artwork for your boat



**20-FT OPEN 5.70 #189 MANIC, 2007.** Redwood City Dry Boat Storage. \$24,000/obo. French built white hull, OD sails, 2 spinnakers (1 new), trailer with lights, dual rudders, depth sounder, Rockbox GPS, lifting straps, keel hoist, full waterproof boat cover, excellent shape, dry sailed, covered. Turnkey fun, fast sportboat, growing OD fleet. [www.vimeo.com/14167375](http://www.vimeo.com/14167375). (509) 637-3761 or [chrismloyd@gorge.net](mailto:chrismloyd@gorge.net).



**20-FT SANTANA, 1972.** San Diego. \$3,900. Trailer, 2.5hp O/B, 2 mains, genoa, jib and 2 spinnakers. Cushions, full cover, lifelines, stanchions, pulpit. Very clean. Race ready or overnight to the island. (760) 727-8910 or (760) 802-2034 or [servpro8724@roadrunner.com](mailto:servpro8724@roadrunner.com).

**ZEPHYR AND TRAILER WANTED.** Please email. [farwest33@netzero.net](mailto:farwest33@netzero.net).



**23-FT RANGER, 1976.** Antioch. CA. \$3,400. Strong and FAST design perfect for Bay/Delta. Double life lines. Manual & electric bilge pumps. 30amp shore power with charger. All sails in great condition. 3 headsails, spinnaker with all gear, new UK Powerhead mainsail. Headfoil. 4 self-tailing winches. Topsides and spars repainted. Mariner 8 HP outboard runs perfectly. Dry holds, solid keelbolts, great interior. Custom cockpit cushions. Turn key! Jump on and go sailing! (925) 597-0441 or [steve60ingram@yahoo.com](mailto:steve60ingram@yahoo.com).

**20-FT PSC FLICKA, 1992.** San Carlos, Mexico. \$30,000. Beautiful Flicka, single-handers package, radar, solar, Espar D2 and much more... Can deliver. Price has been reduced! Check out website and email me with questions, Randy. <http://picasaweb.google.com/sirena.jh/Dulcinea02?authkey=Gv1sRgCLWk1t-B3fXvCA#>. [randy.ramirez@sbcglobal.net](mailto:randy.ramirez@sbcglobal.net).

## 25 TO 28 FEET

**26-FT LAGUNA, 1986.** Redding. \$10,000. With 93 trailer, full set North sails, A-spinnaker never used, roller furling, spare sails, interior carpets and cushions plus cockpit cushions, wheel steering, remote throttle on 7.5 Honda, salon table needs rebuilding. (530) 549-4337.

**27-FT PACIFIC SEACRAFT ORION.** 1980. Channel Islands, CA. \$38,000 or Trade. The boat is undergoing last stages of restoration and upgrades. Sterling paint, new mast, boom, new North Sails, Yanmar 2GM20F diesel, new Raymarine electronics. Lots and lots of extras included. Finished value estimated over \$50K. Need a quick sale, as-is where-is. No owner finance but interesting trades with cash considered. (805) 701-8160 or (800) 200-8839 or [ross@maritimesurveyors.com](mailto:ross@maritimesurveyors.com).



**28-FT ISLANDER, 1984.** Ventura, CA. \$21,900/obo. Nicest I-28 anywhere, this is the one you've been waiting for, 2nd owner, low-hours Yanmar, dodger/bimini, stereo, VHF, Lowrance GPS w/chip, Adler Barbour refrigeration, ST4000 autopilot, hot/cold pressure water, wheel, roller furler, spinnaker gear, outboard hoist, legal head, bottom painted 7/2009. (805) 772-7915 [gregandangiew@juno.com](mailto:gregandangiew@juno.com).

**26-FT MACGREGOR, 1997.** \$7,900/obo. 3 sails, 1 main, 2 jibs. Includes bimini and cockpit side canvas. Rear ladder, anchor, gas stove, bathroom, sail covers and rigging. Engine 1997 8hp, 4-cycle Honda. Very low use, runs perfectly. Bottom epoxy barrier coated. The boat has always been kept on trailer. (415) 342-3181 or [anne-christine@comcast.net](mailto:anne-christine@comcast.net).

**26-FT ZAP, 1979.** \$5,900. Bruce King called this boat, "One of my favorite designs." It's a surfin' ultralite that was so far ahead of its time, YRA made a rule change to disqualify it. Very well constructed and in excellent condition. See more: <http://zap26sail.blogspot.com>. Call (510) 277-2291.



**CAL 2-27, 1977.** San Mateo. \$7,900. Self-tending jib, main, spinnaker, spinnaker pole, whisker pole, new standing rigging, spreader and halyards (2009), VHF, knotmeter, depth meter, solar panel, new tiller, compass, battery and antenna, electric and manual bilge pump, ice box, new holding tank w/sea outlet, teak interior, inflatable dinghy, standing head room, great running Atomic 4, regularly maintained and ready to sail. Great family boat for Bay and Delta. (571) 236-6942 or [rudder\\_web@web.de](mailto:rudder_web@web.de).

**25-FT CATALINA, 1978.** Chamanche. \$5,500/obo. Good condition, E-Z load trailer, drop keel, main and jib included, lazy jacks, new mainsail/tiller covers, two-year-old interior cushions with Sunbrella upholstery, pop top, anchor, fenders, folding galley dinette table, swim ladder, retracting motor mount (outboard not included), extra galley dinette cushions for fold-down bed. (209) 223-2183 or [oannio@comcast.net](mailto:oannio@comcast.net).



**27-FT ERICSON, 1978.** Berkeley, CA. \$10,000. Excellent condition and consistently maintained. Great Bay and coastal cruiser. Sleeps 4. Rugged for singlehanding with all lines leading aft. Wheel with pedestal compass, lifelines and nonskid deck. Alcohol stove, sink, icebox and 20 gallon freshwater tank. New holding tank w/sea outlet. Atomic 4 in top condition. Sails include main w/2 reef points, 155 Mylar, 150 and 110 Dacron, 85% w/Harken roller. Spinn rigging. White with green deck and stripe. (925) 376-9361 or [patflaharty@gmail.com](mailto:patflaharty@gmail.com).

**28-FT HERRESHOFF KETCH, 1950.** San Rafael. \$5,000. Proudly traditional, seaworthy craft built by Lester Ferris (original plans included). Sound wood hull, full keel, all sails, 30hp inboard, Bruce/Danforth anchors, 7' dinghy, GPS, VHF. (415) 261-3958 or [woodydsailor@hotmail.com](mailto:woodydsailor@hotmail.com).



**27-FT ERICSON, 1978.** San Rafael. \$11,000. Good shape. Wheel, jib furling, diesel. Fresh bottom in March (no blisters). Recently spent \$8,000 in upgrades, all new thru hulls, dripless packing gland, muffler. Beautiful interior. Call days. (415) 265-0907 or [gafalbo@comcast.net](mailto:gafalbo@comcast.net).



**27-FT NOR'SEA, 1980.** Moss Landing, CA. \$16,000. Tough little blue water cruiser, safe, easy to handle junk rig, many offshore mods, Fiji vet, aft cabin. Check link for pictures and detailed info at [www.kabai.com/seablossom](http://www.kabai.com/seablossom). Contact (408) 218-9604 or [Kabai@yahoo.com](mailto:Kabai@yahoo.com).

**27-FT ERICSON, 1972.** Gas House Cove, Marina Green S.F. \$6,000. 4 Sale, partnership, trade, lease. Ericson 27 with longshaft outboard. Quiet Gas House Cove slip. Sale \$6,000, partner \$3,000 plus 1/2 slip, lease \$200 plus slip, trade 30-35 footer. Contact Peter. (707) 350-6647 or [pshrive@yahoo.com](mailto:pshrive@yahoo.com).

**27-FT PACIFIC SEACRAFT ORION.** 1979. Alameda, CA. \$48,500. *Aphrodite* gave us great memories and adventures in Mexico. Great condition and cruise ready. Cutter rig, Yanmar diesel, Capehorn windvane, 2 Uni-Solar panels, new asymmetrical spinnaker, propane s/o, dodger, more. Surveyed July 2010. Call (530) 392-5651.

**25-FT PACIFIC SEACRAFT, 1976.** Marina Green. \$10,995/obo. Great bay boat, convenient Marina Green berth \$208/mo, \$1,250 transfer fee or move. Roller reefing, sleeps 5, 8hp inboard diesel. Call email pics. (530) 284-6618, (530) 284-6642 or [blugoose@gmail.com](mailto:blugoose@gmail.com).

**27-FT EXPRESS, 1982.** Alameda. Second owner, never raced. Excellent condition. Full sail inventory. 4hp Yamaha. Trailer. Under full boat cover since new. (510) 845-0858.

**MACGREGOR 26M, 2004.** \$25,000. Trailer and dinghy included. Clean Delta boat, kept in covered storage during winter. Extensive optional equipment. All lines brought aft with jib downhaul. 50hp Evinrude outboard with low hours; serviced 3/10-new water pump. Bottom paint 2008. (707) 374-5627.



**27-FT ERICSON, 1976.** Alameda (Ballena Marina). \$7,500. Sloop-rigged sailboat. Wheel steering with tiller attachment. Standing and running rigging in good condition. 18hp 2-cyl diesel inboard. Self-furling jib added in April 2008. (510) 205-1973 or [mary\\_wilmot@hotmail.com](mailto:mary_wilmot@hotmail.com).

**CATALINA 250 WATER BALLAST.** 1996. Stockton Sailing Club. \$12,950/obo. Roller furling (with cover), Edson pedestal steering, Boomkicker, depth and speedometer, kick up rudder, spare tiller, bimini, life vests (auto inflatable), Honda 9.9 engine, Tandem trailer with mast raising system, sail cover. (559) 479-2094 or [kbernstein@gmail.com](mailto:kbernstein@gmail.com).

## WOODRUM MARINE

Specializing in custom interior cabinetry, tables, cabinets, countertops, cabinsoles. For power or sail.

**CARPENTRY**  
Mobile cabinet shop  
Contact Lon Woodrum at:  
**415-420-5970**  
[www.woodrummarine.com](http://www.woodrummarine.com)

### THE BANDING KIT

A Complete Emergency Repair Kit for use on mast, boom, pole, hose and more. Recommended by the Pacific Cup Yacht Club.

**Don't wait for an emergency!**

415-785-3700 • [www.allusa.com/banding](http://www.allusa.com/banding)



## MikeMaurice @ YachtsDelivered.com

Power - 45 Years Experience - Sail  
Expert- No. Pacific/4Seasons & Bar Crossings  
China-Alaska +1-503-310-7590 - Caribbean

### MARINE SURVEYS by Captain Alan Hugenot

Naval Architect • Yacht Delivery Skipper

Accredited Marine Surveyor (SAMS)

Bay or Delta • No Travel Charges • MC / VISA / AmEx  
[alan@captainhugenot.com](mailto:alan@captainhugenot.com) • (415) 531-6172





**ALPENGLLOW LIGHTS** 406.889.3586

**Hand Crafted, High-Efficiency Area Light**  
LED Swivel Reading and Berth Lights in Chrome or Titanium (Brass) Finish

Brighten your cabin with better light quality, superior color rendition, and lower battery drain! Selection of wood choices for fixtures. Splash-proof and Night-vision models available. Dual power for bright light or gentle glow, and two levels of red.



Alpenglow Lights, LLC, P. O. Box 415, Eureka, MT 59917  
debi@alpenglowlights.com • www.alpenglowlights.com



**Save Your Aft!**

Using one of our 1900+ patterns or your own pattern, let our craftsmen create a comfortable, durable, and stylish set of all-weather cushions for your cockpit. Find your custom, closed cell foam cushions at [www.bottomsiders.com](http://www.bottomsiders.com)!

**SEE US AT THE ANNAPOLIS BOAT SHOW OCT. 7-11**

**BottomSiders**  
2305 Bay Avenue  
Hoquiam, WA 98550

Call Toll Free: (800) 438-0633  
cushions@bottomsiders.com  
Fax: 360-533-4474

**BAY MARINE SURVEY, LLC**

**JESSE BRODY, SAMS-AMS**

- Pre-purchase and insurance condition & value surveys
- Comprehensive inspections with detailed reports
- Based in Berkeley and serving all of San Francisco Bay

 SOCIETY OF ACCREDITED MARINE SURVEYORS®

 STANDARDS 43YC ACCREDITED

[WWW.BAYMARINESURVEY.COM](http://WWW.BAYMARINESURVEY.COM)  
415.342.0757

**COMPUTER ABOARD?**

CAPN & Digital Charts  
AIS • WiFi • Cellular Amps  
SatPhones: Iridium & Globalstar  
HF SSB Radio & Pactor Modems  
*Wireless E-mail*



**SEATECH SYSTEMS™**  
800.444.2581 • 281.334.1174  
info@sea-tech.com • www.sea-tech.com  
Call for Info on SeaTech Packages and CAPN Demo Disk

SEE US AT THE ANNAPOLIS BOAT SHOW



**27-Ft O'DAY, 1978.** San Rafael, CA. \$9,900. Great sailing boat - consistently sailed, maintained and upgraded. Clean turnkey race winner. Comfortable cruiser. Yanmar diesel. Dual AGM's, inverter, Martec folding prop. Dripless shaft seal. ProFurl AP with remote. (415) 269-3140 or windride27@gmail.com.



**27-Ft CATALINA, 1977.** Redondo Beach. \$9,500/obo. Completely restored. Atomic 4 inboard gas great condition! VHF, handheld GPS. NEW: mainsail, jib furling, all paint, compass, depth sounder, lots more. Please email me for full list and more photos! (818) 726-5098 or pascalenyby@gmail.com.

**27-Ft CATALINA, 1978.** Berkeley. \$5,900/obo. Joy. Unique w/custom portholes, roller furling. Ready to sail, upgraded chainplates, recently tuned rig. Running Atomic 4. Huge owner network. Coastal cruiser. Liveboard ready. Transferable slip. [www.flickr.com/photos/53701147@N07/](http://www.flickr.com/photos/53701147@N07/). (310) 903-9501 or lobster@brindze.com.

**29 TO 31 FEET**



**28-Ft HAWKFARM, 1976.** Alameda. \$16,000/offer. Eclipse. Excellent condition. Immaculately maintained by original owner. Fully equipped. Ready to race or cruise. Bay or Ocean. Storied racing career, comfortable cruiser. New Yanmar inboard diesel. Many sails. Electronic package. Many extras. (510) 522-4006 or fredric.hoffman@gmail.com.



**29-Ft PEARSON TRITON, 1966.** Redwood City. \$5,000/obo. Turnkey-ready, well-maintained classic offshore cruiser. Raced on 7/17/2010, placing 2nd out of 7 Tritons in the annual BVBC Plastic Classic. Photos on Craig's List. Bought bigger boat, must sell. See more at <http://sfbay.craigslist.org/boa/>. (650) 780-9914 or chuckmillar@gmail.com.

**25-Ft MERIT, 1974.** Richmond Yacht Club. \$3,500. New standing and running rigging. New bottom paint. 2002 Honda 5hp outboard long shaft. (925) 462-8257 or (510) 610-8879 or glenn.davis40@comcast.net.

**31-Ft HUNTER, 1984.** Ballena Isle Marina, Alameda, CA. \$25,000. Very good condition. Full dodger, roller furler, Quest 150 custom genoa, spinnaker pole, Raymarine radar/chartplotter and autopilot, cockpit table, Yanmar diesel, VHF radio, CD with 6 speakers, low wattage inverters, (2) new batteries, 2009 bottom paint, H/C pressurized water, (2) burner stove with oven, BBQ, inflatable mini-dinghy, self climbing Top Climber. All Coast Guard required safety equipment, charts and books, (2) anchors and rode, Buoy hook. Too much more to list. (775) 626-2679 or (775) 722-1600 or pcscarli@aol.com.

**25-Ft CATALINA 250 WATER BALLAST.** 1995. Benicia. \$17,988. With trailer and mast raising system. 8hp Honda 4-stroke long shaft, all new navy blue canvas, snorkel, wheel cover, carpets, etc. Wheel w/pedestal. Boat is immaculate. Will not disappoint. Very hard to find. (707) 696-9600 or cogswell1777@yahoo.com.



**CATALINA 30 MK I, 1979.** Rio Vista. \$8,900. Tiller, Atomic 4 good runner, recent 110 genoa w/roller furling, interior woodwork in very good shape. (559) 284-2144 or oblomenow@gmail.com.

**25-Ft CATALINA 250 WATER BALLAST.** 1995. Benicia. \$17,988. With trailer and mast raising system. 8hp Honda 4-stroke long shaft, all new navy blue canvas, snorkel, wheel cover, carpets, etc. Wheel w/pedestal. Boat is immaculate. Will not disappoint. Very hard to find. (707) 696-9600 or cogswell1777@yahoo.com.



**Repair, Restoration & New Construction**  
**(510) 522-2705**

**Fred Andersen Boat & Woodworks**

**STARBOARD YACHT DELIVERIES**

Over 50,000 sea miles • Pacific, Caribbean, Atlantic  
USCG Master 100 GT STCW • Power & Sail

**Rick Whiting • (415) 740-2924 • captain\_rick@sbcglobal.net**



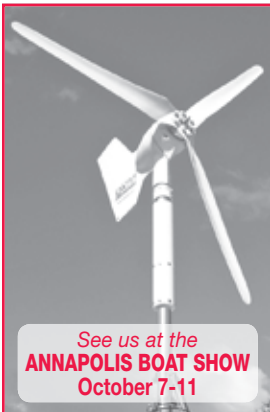

## MORE ENERGY!

### KEEP BATTERIES CHARGED!

- KISS wind generators
- Solar panels and MORE

### USE BATTERIES EFFICIENTLY!

- LED lights
- Engel fridge/freezers
- Wonder Wash and more



See us at the  
**ANNAPOLIS BOAT SHOW**  
October 7-11

[www.svhotwire.com](http://www.svhotwire.com)

**727.943.0424**

## Marine Diesel Specialists AT YOUR SLIP!



30 years experience • Universal/Westerbeke dealers  
Repairs/Tune-ups all models • Engine Surveys, Instruction

**BAY MARINE DIESEL**

**510-435-8870**

[baymarinediesel@comcast.net](mailto:baymarinediesel@comcast.net)

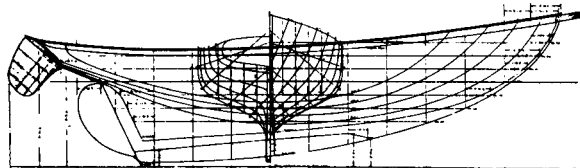

## MAKELA BOATWORKS

Family owned since 1948

**Wooden Boat Building • Repair and Restoration**

19280 South Harbor Drive • Fort Bragg, CA 95437

**(707) 964-3963**

email: [howard@makelaboatworks.com](mailto:howard@makelaboatworks.com) • [www.Makelaboatworks.com](http://www.Makelaboatworks.com)

**FAST SHIPPING!**

## NEW AND USED SAILS!

Specializing in production boats and featuring the largest selection of stock sails available anywhere! Save with warehouse volume discounts on Stock Sails, Custom Sails, Sail Covers, Furlers and Accessories. All top Quality.

**All Fully Guaranteed!**

- Full Batten Mains
- Furling Genoa's
- Storm Jibs
- Trysails
- Furling Units
- Custom Canvas
- Used Sails

**THE SAIL WAREHOUSE**

**THE SAIL WAREHOUSE**

**Ph. (831) 646-5346**    [www.thesailwarehouse.com](http://www.thesailwarehouse.com)



**33-FT HANS CHRISTIAN, 1980.** San Diego. \$119,000. Change of plans! Fully refitted for S. Pacific voyage. New Yanmar, electronics, watermaker, sails, rigging, batteries, solar, canvas, dinghy and spares. Loads of cruising gear. Ready to go. (619) 319-0136.



**34-FT PEARSON, 1984.** Wilmington. \$41,250. Original owner. Fin keel. Great condition with 110 genoa and blade storm jib. Autopilot, propane stove/oven, wheel steering, battery charger, H&C pressure water, must see, 20 hp original Yanmar diesel engine. [pinkclan4@comcast.net](mailto:pinkclan4@comcast.net).

**34-FT HUNTER, 1984.** Sausalito, CA. \$24,900. If you can find a cruise-ready sailboat at this price, take it! This is a 34-ft sailboat that could leave for Mexico tomorrow. Just fill up the water and fuel and turn left after leaving the Golden Gate. Any takers? This is an excellent, first time boat that is rigged for singlehanded and operates well under all conditions. I love this boat, but I am now the owner of another boat, so it is time to sell. This Hunter is priced to move. Photos and a detailed description of the boat can be found at: <http://witchdoctorsailboat.webs.com>. (415) 497-6116 or [medicrene@yahoo.com](mailto:medicrene@yahoo.com).

## 36 TO 39 FEET



**36-FT ALLIED PRINCESS, 1977.** San Rafael, CA. \$40,000. This well regarded cruising ketch has undergone a major refit over the last five years, including new rigging, electronics, sails, and hull LP paint. The boat has had three owners, and all maintenance documents, including original delivery manuals are onboard. (707) 364-0801 or [rkhurt@comcast.net](mailto:rkhurt@comcast.net).



**35-FT COOPER 353, 1981.** San Diego. \$64,900. Roomy, solid coastal cruiser. Excellent condition with many improvements. New engine, batteries, wind generator, nav equipment. Good looking boat inside and out. Divorce sale. See details and pictures at: <http://picasaweb.google.com/114099174294335707289/Cooper353#>. (928) 699-0986.

**37-FT GULFSTAR, 1978.** Berkeley Marina. \$27,500. Great boat to sail, roomy, comfortable and very stable. Extensive rehab in 2002, new standing and running rigging, thru-hull fittings, roller furling, head and holding tank and more. (619) 244-2144 or [jimhumphrey@cox.net](mailto:jimhumphrey@cox.net).



**32-FT ERICSON, 1971.** Bruno's Island, Isleton. \$18,900. Great cruising and Bay boat. Well maintained, excellent mahogany interior, new bottom paint. Three headsails, spinnaker, lines led back, self-tailing winches, Yanmar diesel, LectraSan sanitation, depth sounder, knotmeter. (510) 207-0111 or (510) 525-3572 or [don@dondommer.com](mailto:don@dondommer.com).



**39-FT CAL, 1980.** Berkeley. \$59,000. Great Bay and Delta boat. Lots of upgrades completed in the last 12 months. Terrific sailing qualities and offshore capable. Maintenance records and photos available, Perkins 4-108 with wide range of sails. (916) 208-3606 or [gary.greule@gmail.com](mailto:gary.greule@gmail.com).



## OFFSHORE PASSAGEMAKING INSTRUCTION IN THE SOUTH PACIFIC

John & Amanda Neal are dedicated to providing hands-on, documented instruction aboard their Hallberg-Rassy 46 *Mahina Tiare III*, drawing on their combined 502,000 miles and 66 years of experience.

[www.mahina.com](http://www.mahina.com) • (360) 378-6131

*Going Somewhere?* **Mexico • Caribbean • South Pacific**

Stop by our office and take a bundle of *Latitude 38* along with you.

*We promise you'll be a hero for sharing them with other cruisers!*

**Latitude 38 • 15 Locust Ave • Mill Valley, CA • (415) 383-8200 • Open M-F 9-5**



**38-FT CAT KETCH, \$49,000, ASKING.** This easily handled Halsey Herreshof-designed Cat Ketch 38 has unstayed carbon fiber masts: no standing rigging to worry about, no foresails to contend with. She averaged 7-8 knots from Puerto Vallarta to Napa. The hull is of sandwich construction with Airex closed-cell foam. The Caribbean pine interior features two private cabins, each with a head (one of which has a composting toilet). She is well equipped with radar, autopilot, watermaker, ultraviolet water purifier, fuel system algae remover, new Awlgrip paint and brand new sails. (707) 254-0220.

**38-FT HUGHES, 1970.** Monterey, CA. \$21,000/make offer. Canadian built S&S design. Sound hull, low hours on nearly new diesel engine. Sails nicely, needs TLC & newer/upgraded equipment. (831) 915-4984 or coffina@sbcglobal.net.

**37-FT TARTAN, 1976.** Maryland. \$34,000. Bahamas, Caribbean? Budget cruiser, go now. Good old boat. New Harken furler, radar, SSB, solar, '08 FB main, windlass, AP, frig, inverter. Centerboard missing, sweet sailing S&S design. If not now, when? (301) 974-2620 or tw33432@yahoo.com.



**38-FT ALAJUELA, 1976.** Sequim, Washington. \$129,000. Well maintained and equipped 38-ft FRP cutter. Stoutly built for offshore cruising. Many improvements including new engine 2005. Go to blogspot for full details and photos: <http://alajuela38.blogspot.com>. (360) 683-8662 or svselah@yahoo.com.

**37-FT CREALOCK CUTTER, 1980.** Monterey. \$45,000. Ballenger tabernacled mast. New Yanmar w/saildrive, radar, GPS, easy access to all systems, 70gal diesel, 3 watertight bulkheads. Not in yacht condition, needs finish work. Great little sailing ship. Price firm. Email ddatpbio@gmail.com.



**38-FT KETTENBURG, 1956.** 3 Available. "Nice boat!", "Beautiful boat!", "Gorgeous boat!" heard many times from other boaters during every sail. Enjoy character, admiration, and fantastic sailing while sustaining the heritage. More details at: [www.sailk38.com](http://www.sailk38.com). (916) 847-9064 or steve@paradigmpilgrim.com.

**36-FT HUNTER 356, 2003.** Alameda. \$92,900. Beautiful boat. Very spacious interior. New bottom paint. Save thousands over buying through a brokerage. See all details and photos on the listed web page. <http://web.mac.com/laynegalloway>. (801) 419-4100 or laynegalloway@msn.com.



**HANS CHRISTIAN 38 MK II, 1985.** Savannah, Georgia. \$80,000 motivated. Price lowered!! New epoxy glass hull, shaft, MaxProp, cutlass and stuffing box, 300' of 3/8 HT chain primary, 100' 3/8 HT on 300' rode secondary ground tackle from Svendsen's Aug. '09, new keel-cooled Frigoboat unit, new Lectra-Scan. Raymarine radar and chartplotter. Two mains-one full batten, 130 jib, staysail, storm sail, inner forestay blooper sail. Ready for Med or Fiji. (404) 354-3855, (770) 710-7079 or joe\_millsaps@yahoo.com.



**38-FT HUNTER 380, 2001.** San Diego, CA. \$119,000. Well loved Hunter 380 for sale by owner. Lots of equipment and extras... ready to go! Go to her website for pics and full specs: [www.hunter380.com](http://www.hunter380.com), or call us and we will fax or email them to you. (909) 721-2095 or (909) 721-0891 or dcafr2@yahoo.com.

**37-FT ALBERG, 1980.** Port Townsend. \$60,000. Excellent condition, well maintained. Lots of sails. Profurl roller furling, Volvo diesel, windlass, monitor and Autohelm self-steering, GPS, VHF and sideband radios. Bruce anchor, 200' chain dinghy and outboard, recent survey. Contact James. (360) 765-3222 or jarsulich@olympus.net.

**39-FT FREYA IN STEEL, 1974.** Oxnard, CA. \$35,000/obo. Freya Halvorsen 39 steel sloop. Insulated, rebuilt 85hp Ford diesel. Autopilot, radar, GPS, fridge, shower, hot water. Hood roller furling, hydraulic windlass, sounder, dodger, refurbished aluminum mast/boom. 8-ft dinghy. (805) 200-6089 or traim69@hotmail.com.

**37-FT PEARSON INVICTA YAWL, 1967.** Oakland, CA. \$25,000. Monitor vane, solar panels, hard dodger, windlass, heavy anchors, roller furling, recent bottom, new propane stove, heater, chart plotter, charger, stereo. Needs Westerbeke diesel installed, new hatch secured. Ready for cruising. (707) 758-4417 or trilightsailor@gmail.com.

**39-FT SWAN 391, 1986.** Puerto Vallarta, Mexico. \$149,000. 39'10" LOA, designed by Ron Holland. Excellent condition with low engine hours. Major refit 2007-2010 with new standing & running rigging, batteries & charging, windlass, etc. VHF, SSB, W/Fx, B&G instruments. Email ilalovic@hotmail.com.

## 40 TO 50 FEET



**43-FT 435 BENETEAU, 1985.** Marina del Rey. \$129,000. A rare pedigree French export. Open checkbook refit and maintenance. Huge equipment list. Tall rig. 12 ST Lewmar's, Harken, low-time Perkins, all B&G's w/pilot, custom panel, Furuno radar/GPS. Perfect teak decks. Huge aft stateroom. Navtec and Quantum, etc. Swan looks-Frers speed. Sistership in book "World's Best Sailboats". Timeless beauty. Turnkey. (310) 666-4546 or (310) 550-0742 or berniefried@gmail.com.

**40-FT HUNTER LEGEND, 1986.** La Paz, MX. \$68,000. Cruise ready for the 2010/11 season, full electronics, comfortable performance cruiser. Constantly upgraded with newer equipment. Call or write for details and pictures. Save money by buying in Mexico. (530) 957-2810 or gregondetente@gmail.com.



**45-FT SPARKMAN & STEPHENS.** Seafarer Yawl, 1962. San Francisco. \$75,000. Yacht *Soltura*. Built in Holland in 1962 of hand-laid fiberglass. Seven Seafarer 45's were built, and their high quality of construction is evident. Great size for the Bay, Delta and Pacific. Sea-kindly and easily handled by two people. Contact Jerry. (415) 435-3513 or gsrmsley@yahoo.com.



**40-FT PETERSON IOR, 1979.** Singlar Marina, Guaymas, Mexico. \$90,000. Alum. hull, Pathfinder 50, watermaker, electric windlass, 66 Bruce, Profurl, hard vang, spinnaker/whisker poles, full batten 3 reef main, Strong Track, 5 headsails, boom brake, winches-2 3-speed, 5 self tailing, radar, GPS, depth sounder, autopilot, windvane, 2 solar panels, 100 amp alternator, 8 AGM, 2 inverters, stove/oven, Lavac head, refrigerator-7.2 cubic ft. (435) 513-1556 or s.blues1@yahoo.com.

**46-FT PETERSON CUTTER, 1981.** \$165,000. Change of plans. Ready to cruise, everything new! MaxProp and shaft, Xantrex inverter. All Raymarine electronics, autopilot, Furuno radar, water and fuel tanks, Lofrans, cruising Mylar main+135%. Spin & sock, Furlex, Awlgrip hull and deck. (805) 469-3014.



**43-FT ROBERTS 434.** Corten Steel Pilothouse, 1997. Tomales Bay. \$75,000. Serious offshore cruiser ready to go. Corten steel, modern underbody, Yanmar 75 turbo 350hrs, radar, watermaker, 640w solar, Lofrans windlass, good sails with cockpit sail handling. See more at <http://sites.google.com/site/svfunkadelic/>. Email svfunkadelic@gmail.com.



### SMALL AD, SMALL PRICES • RIGGING ONLY

Standing and running rigging, life lines, furling gear, winches, line, windlasses, travelers, wire and terminals, blocks, vangs, and much more.

~ ~ ~ Problem solving and discount mail order are our specialties ~ ~ ~  
[www.riggingonly.com](http://www.riggingonly.com) • (508) 992-0434 • email: [sail@riggingonly.com](mailto:sail@riggingonly.com)

*Need Crew? Latitude 38 Crew List A Boat to Crew on?*

Visit our website and sign up as Skipper or Crew • It's Free

Find out about our next Crew Party at:

[www.latitude38.com/crewlist/Crew.html](http://www.latitude38.com/crewlist/Crew.html) or call (415) 383-8200



### PROFESSIONAL DELIVERY CAPTAINS

San Diego based, USCG Master 100 GT. Sail and power.

ASA-certified instructional deliveries. Pacific Mexico and Baja Bash specialists.

[davidhbrotherton@yahoo.com](mailto:davidhbrotherton@yahoo.com) • [www.boatdeliverycaptain.org](http://www.boatdeliverycaptain.org)  
 • (619) 913-7834 •

### COMPLETE MARINE WOODWORK

Design / Restoration • Expert European Craftsmanship • Interior / Exterior  
 Repairs / Maintenance • Marine Windows & Frame Replacement  
 Wood & Dry Rot Repairs • Varnish Work • Marine Painting  
 References Available • Reasonable Rates • Call (415) 331-6718

# Mathiesen Marine

For all of your electronics and electrical needs

*End of Season Sale - Lowest prices of the year on all brands of electronics!*

Raymarine Mobile Showroom on site  
Saturday & Sunday, October 16th & 17th



3300 Powell Street, Emeryville

(510) 350-6622 [www.MathiesenMarine.com](http://www.MathiesenMarine.com)



## Donate your Boat

**Cars, Trucks, RVs, & Real Estate**

We handle all DMV & Smog  
Running or Not

**Tax Deduction**

**BLUEWATER NETWORK** | **800-324-7432**

"Proceeds help **Bluewater Network** reduce greenhouse gases, clean up our air and water, and protect marine mammals and wildlife."

We are always  
looking out for you!

American Yacht Insurance for boats over  
26 feet. We provide cover for any flag  
registration or navigation.



**PANTAENIUS**  
American Yacht Insurance

Germany • Great Britain • Monaco  
Denmark • Austria • Spain • Croatia  
Sweden • USA\*

500 Mamaroneck Avenue Suite 318  
Harrison, NY 10528  
Phone (914) 381-2066

Newport Shipyard  
One Washington Street  
Newport, RI 02840  
Phone (401) 619-1499

[www.pantaenius.com](http://www.pantaenius.com)

\*Pantaenius America Ltd. is a licensed insurance agent licensed in all 50 states. It is an independent corporation incorporated under the laws of New York and is a separate and distinct entity from any entity of the Pantaenius Group.

## WEDLOCK, RAMSAY & WHITING Marine Surveyors

Vessel surveys,  
consulting, deliveries.

Serving the  
Bay Area  
since 1980



[www.norcalmarinesurveyors.com](http://www.norcalmarinesurveyors.com)

**(415) 505-3494**

**44-FT KELLY PETERSON, 1977.** Kemer/Antalya Turkey. \$90,000.00. Fully loaded/ready for cruising. Perkins 4236/1993 90hp engine rebuilt 2009. 5 sails including beautiful chute. In process of installing Raymarine HD radar. PUR watermaker, solar panels, KISS wind generator, 2009 AGM batteries, much, much more. Located on the beautiful Turquoise Coast at Kemer/Antalya, Turkey. See marina website: [www.Kemerturkizmarina.com](http://www.Kemerturkizmarina.com). Will be on board October/November. Rent paid to May 2011. [jking38701@aol.com](mailto:jking38701@aol.com).

**41-FT MORGAN CLASSIC MODEL.** 1991. San Carlos, Mexico. \$98,000. Primo condition. Equipped and ready to cruise. Center cockpit, great liveaboard, must see to appreciate roominess. Recent survey. See blog for equipment list and current photos, <http://sailboatvagari.blogspot.com>. Contact (520) 825-7551 or [stanstreb@gmail.com](mailto:stanstreb@gmail.com).



**44-FT CATALINA MORGAN 440, 2005.** Napa. \$220,000. In great condition. Completely set up for cruising and has sailed to Tahiti and back. Roller furling, inner forestay, autopilot, radar, chartplotter, dodger, 120 Vac inverter, 600 AH battery bank with quick charge system, 75hp diesel engine, VHF, stereo, 2 zone cabin HVAC, refrigerator and freezer, watermaker, dinghy davits, 4 sails including asymmetrical spinnaker. Call Denny for more details. (707) 486-0412.

**J/41, 1985 SPINDELETT MARINA.** Isleton. \$210,000. Race, V-berth, interior, refrigerator, radar, 2 auto and 2 years in Mexico.



**40-FT FORMOSA KETCH, 1975.** Marina Bay, Richmond. \$25,000. 40ft O.A., 34ft O.D. Glass hull. Partially rebuilt 2001-present. Replaced items with new includes engine, masts, electrical, electronics, etc. Excellent liveaboard. Complete inventory. (415) 302-9944 or [mpayne@camarin.org](mailto:mpayne@camarin.org).

**45-FT DOWNEASTER CC, 1980.** La Paz, Mexico. \$Best offer. This California-built boat was refit in 2004. Our plans have changed and we will make this an excellent deal for new owner. Can be seen at website: [www.mazmarine.com](http://www.mazmarine.com). (941) 204-3271 or [kruzn2004@aol.com](mailto:kruzn2004@aol.com).



**GULFSTAR 43 MK II.** center cockpit ketch, 1979. San Diego Pier 32. \$89,000. Much loved ketch, easily handled by two. Great liveaboard with 2 cabin, 2 head layout, great galley. Perkins 4-108. Continually maintained. Ready for cruising, just add electronics and go. See detailed specifications and photos at [www.svDreamKetcher.com](http://www.svDreamKetcher.com). (805) 558-9969 or [skipper@svDreamKetcher.com](mailto:skipper@svDreamKetcher.com).



**50-FT HERRESHOFF CARIBBEAN.** 1978. Napa Marine. \$199,500. 14.5' beam, 6' draft, Perkins 6-354, radar/AP/SSB-Ham, VHF, Probe, 6-person raft, spares, tools, dinghy/motor. Fresh interior refinish. Not a fire sale. Serious inquiries only. [www.sailboatlistings.com](http://www.sailboatlistings.com). Call (707) 834-4798.

**50-FT FD-12, 1981.** Mexico. Unsinkable 50-ft cutter, AK/Mexico/SoPac vet. Superb galley in pilothouse: generous counter space, good daylight and view. Berths for 5-6 in 2 staterooms forward and master stateroom aft (privacy for parents w/children or guests). More at [www.svdaydreamer.com](http://www.svdaydreamer.com). Call (928) 717-8812.

**40-FT DELPHIA GT TALL RIG 2 CABIN.** 2008. Sausalito, CA. \$268,000. Rare combination of high performance sailing AND hand crafted old-world mahogany interior. Built tough for the Baltic; built beautifully for comfort and sophisticated tastes, this import is LOADED. Dealer demo with ocean coastal shakedown and SF Bay demo sails the only mileage. PRACTICALLY NEW. Serious inquiries only, this boat MUST be seen. Full specs and pictures on dedicated website: <http://delphia40gt.info>. Leave contact info or call John at (415) 332-5209.

**INTERNET FRAUD.** Recently, we've been getting more reports of a new twist in Internet scams, so we feel compelled to warn you once again about this unfortunate aspect of human nature. The newest scam is for someone to give you a check for \$2,500 over the asking price, (or a deposit), to cover test drive fees, inspection or delivery costs. They have transporters available. Then they will ask you to cash the check and pay the transporters or drivers, keeping your cut. Then, much later, the bank informs you that the check was no good. You will be out the \$2,500. We recommend that you don't even respond to the initial email inquiry. For more info on these cons, see: [www.craigslist.com/about/scams.html](http://www.craigslist.com/about/scams.html). Brave New World.





**41-FT BENETEAU OCEANIS 411, 2001.** Mediterranean. \$139,000. The perfect couple's cruising boat with offshore capabilities. Two cabin owner's version. Designed by Groupe Finot and built by Beneteau in France. Well-equipped and meticulously maintained. Never chartered. Stored on the hard at least six months per year since new. Only 1,100 hours on Volvo 59hp engine. No sales tax, personal property tax, or value added tax for USA buyers. USCG Registered. Lying in the Med. (415) 269-4901 or sail@voleauvent.com.

**48-FT ISLANDER, 1985.** Sausalito. \$185,000. This is a classic Ted Brewer design built by Islander. Pristine condition, 3-year renovation just completed. Just about everything is new, sails, rigging, plumbing, pumps, etc. Call or email for all the information. (415) 846-6919 or sailonbaby@gmail.com.

**40-FT HANS CHRISTIAN CHRISTINA.** 1988. Peninsula. \$125,000. Modern design, light teak interior, Pullman berth and aft stateroom, Cape Horn self-steering, self-tailing winches, sails beautifully. Plans changed, not using it very much. Contact via email or leave message on phone. HCchristina40@gmail.com or (650) 563-5686.



**51-FT STEEL KETCH.** Super world cruiser, Ventura. \$119,900. 51' overall, 44' on deck, 40' at water line, beam 12'11", draft 5'10". Ford Lehman, 80hp diesel engines with low hours. *Felicity* has radar, AP, dodger, inverter, furling jib and genoa, Bristol condition paint and varnish, mahogany interior with many other features. Built in Holland with the finest quality of steel construction, and has been professionally maintained by her owners for the past 25 years. This is a stout, well-built offshore cruiser. She has a draft of less than six feet and 250 gallons of fresh water capacity. Email for more information and pictures. Market value: \$165,000. Now: \$119,900. Replacement cost exceeds 1 million dollars. (805) 290-6119 or (805) 650-8888 ext: 133 or dennis@survivalsystems.com.



**55-FT FIBER STEEL, 1980.** River View Marina, Sacramento \$Make offer/Must sell. 72' LOA, 16' beam, F/C, 671 main engine with 300 hrs. 15KW gen, 1100 gals. diesel, 500 gals. fresh water, ketch rig. New sails, 6'6" head room, sleeps 8. Dinghy and new electronics, 385' 3/8 ht chain, 2000 lb windlass, 2 heads, shower, ice maker, 2 refrigerators/freezers. Great liveaboard with liveaboard slip. 7 minutes to downtown Sacto. Possible trades? Health forces sale. (916) 208-4141 or seahawk2mexico@gmail.com.

## 51 FEET & OVER



**65-FT FREEDOM, 1981.** Berkeley Marina, L. Dock. \$65,000. Fiberglass/balsa core, 200hp Volvo Penta diesel, about 100hr. 3-carbon fiber mast, sail plan not finished, bottom kept up - in good shape, boat needs work. This is one big boat! 18-ft beam, lots of headroom. Contact (510) 701-5846 or ronwmail@yahoo.com.



## CLASSIC BOATS

**27-FT SEA ISLANDER, 1954.** Alameda. \$12,000. 32 ft. overall, sloop rig, mahogany on oak, bronze fastenings, new diesel engine, 90% new oversized standing and running rigging. Professionally and lovingly maintained. Serious inquiries only. (925) 933-4252 or (510) 506-8578 or sandrabackovich@sbcglobal.net.

## MULTIHULLS

**42-FT KURT HUGHES CRUISING CAT.** \$10,000/obo. Both hulls are about 65% complete, but unfinished. The builder ran out of time and money. Hulls have been turned. Includes the plans. (805) 461-0434 or (805) 235-7937 or michaelcurtis7982@sbcglobal.net.



**32-FT PDQ, 1997.** SFYC. \$129,900. Price reduced. Absolutely Bristol. Survey/refit 2009. New sails, batteries (5), dodger, engines (100hrs). Two 135W solar panels. Raymarine plotter/radar/tridata instrumentation. Spinnaker. Central heat/AC, microwave/instant hot water/frig. Bose sound system with flat TV and more. Must see. Replacement value 200k. (415) 497-1350.

**50-FT PRIVILEGE 495, 2002.** San Diego. \$680,000. French built Privilege 495. Great condition, ready to sail. In San Diego in October. See more at <http://catamarankertidou.blogspot.com>. (619) 208-9985 or thierrybonnefille@yahoo.fr.

**45-FT CASAMANCE, 1988.** San Carlos, Mexico. \$195,000. Fantastic Fountain Pajot catamaran proven blue water cruiser. 3 staterooms plus tool room. Roller furling main and headsails. Diesel generator, 160 amp alternator and 24 GPH watermaker. Email for photos, additional information. (209) 743-6275 or (209) 694-4609 or vik@inreach.com.



**34-FT CROSS TRIMARAN, 1980.** La Paz, Baja California. \$10,000. This Cross 34 Trimaran lost its mast 2 months ago; it is now stored out of the water at Marina Singlar in La Paz. It has dagger boards, kickup rudder, retractable bow sprit, watermaker, radar, dinghy, wind generator, great sails and much cruising equipment. It needs a new mast (3-5 available in La Paz) and work to fix cracks in the deck. (619) 992-8496 or trimarandan@hotmail.com.

**31-FT CORSAIR F31, 1995.** Ventura. \$84,000. Aft cabin F31 set up for singlehanded sailing. Factory modified transom-hung rudder. 2 full suits of sails, GPS chartplotter, autopilot and wind speed/direction/depth. Trailer w/stainless disc brakes. Many more upgrades. See more at [www.corsairf31forsale.com](http://www.corsairf31forsale.com). Email bangorang16@aol.com.

**35-FT MARPLES CC.** \$20,000/obo. Hulls completed; Yanmar diesel installed, 5 bags of new sails, mast, boom, winches, rigging, super prop, anchors, and most everything needed to complete the boat. Marplescc35@yahoo.com.

## POWER & HOUSEBOATS

**37-FT CHRIS-CRAFT CONSTELLATION.** 3 cabins, 1963. Emeryville. \$13,000. Great liveaboard! Classic, spacious, large windows, lots of storage, very clean. Sleep 6. New beautiful twin engines, head, carpets, fridge. Needs some underwater hull repair, estimated at \$6,000. (510) 904-2297 or zorarise@yahoo.com.

**32-FT NORDIC TUG, 1998.** Benicia. \$140,000. Rugged construction, fuel efficient, reliable, solid and stable: cruise in comfort and safety. 220 Cummins diesel (312 hrs.), Northern Lights genset, bowthruster, full electronics, transom door. Recently cruised R/T to Catalina - Mexico anyone? (707) 297-6535.

**54-FT SAGAR 16 METER BARGE, 2002.** Central France. \$290,000. Custom built for all navigable waterways. 2 Brms, 2 bath. Complete inventory for comfortable cruising. See website for photos and complete inventory. Sagar has a two-year waiting list for new build. Owner financing. See more at <http://web.me.com/cbroussard/Acadia/Welcome.html>. Email pat1083@sbcglobal.net.



**65-FT WOOD CLASSIC, 1939.** Heavy built ex-trawler. GMC 12V-71, 21-kw generator. Full electronics. Lots of equipment. Ready to go. Would make great conversion. Will consider any reasonable offer. More pics/details: (707) 964-5423 or ancona@mcn.org.

**32-FT GRAND BANKS, 1967.** Ocean Springs, MS. \$45,000/obo. Really nice. Buy as-is or I can finish. There is not \$10,000 left. New photos coming online. Lots of work done here by me. Bought larger boat. <http://webworldusa.com/gbforsale.html>. (805) 637-9748 or sundaymorning2@hotmail.com.

### JORDAN SERIES DROGUE

Revolutionary Storm Survival Device  
"As if by magic, stability appears out of wild movement"  
Ace Sailmakers <http://JordanSeriesDrogue.com>  
860 739-5999 [AceSailmakers@yahoo.com](mailto:AceSailmakers@yahoo.com)

### Latitude 38 eBooks

FREE ★ AVAILABLE WORLDWIDE ★  
[www.latitude38.com/ebooks.html](http://www.latitude38.com/ebooks.html)

### MULTIHULL YACHT DESIGNER • MARINE SURVEYOR

John R. Marples, CMS • Certified, National Association of Marine Surveyors  
Multihull Design Specialist • Pleasure and Commercial  
Design office for Jim Brown Searunner, Seaclipper & Constant Camber Multihulls  
[www.searunner.com](http://www.searunner.com) • (707) 343-1378 • [marplesmarine@comcast.net](mailto:marplesmarine@comcast.net)

### boat bottom scrubbing & more . . .

415.331.7215 [william@gotzinc.com](mailto:william@gotzinc.com) [www.gotzinc.com](http://www.gotzinc.com)

*Simply Great Sleep*

Transform your mattress with our box-spring system and enjoy many relaxing nights aboard.

**Froli**

phone 888.463.7654  
Nickle Atlantic, LLC  
www.FroliSleepSystems.com

See us at the Annapolis Boat Show

**BLUE PELICAN MARINE**  
Nautical Consignments

*A Sailor's Consignment Chandlery*

Official Sponsor  
2010  
BAJA  
HA-HA

**510-769-4858**  
Located at Grand Marina  
www.bluepelicanmarine.com

Mobile Marine Navigation  
Installations and Marine  
Electrical Work

**Vessel Electric**

Serving all corners of the Bay:  
North, South, East -  
and San Francisco!

**Raymarine**  
certified installer

Milltech Marine AIS **NAVPOD**

Brian Theobald • (415) 424-2204 • vesselelectric@yahoo.com

**ATLANTIC 57 CATAMARAN™**

THE ORIGINAL PILOTHOUSE CATAMARAN

- o Designed for easy shorthanded cruising
- o Spectacular windward performance
- o Cored epoxy/glass/carbon construction

**CHRIS WHITE DESIGNS**  
TEL: 508-636-6111  
www.chriswhitedesigns.com

**PARTNERSHIPS**

**1/4 NON-EQUITY PARTNERS IN Coronado 27.** Nice interior, two jibs, solid outboard, kayak. Great berth at Sausalito Yacht Harbor. First right to boat, 1 week out of four, when available other weeks. \$150/month. For info or photos: flyboar@aol.com.

**CATALINA 34 50% EQUITY partnership,** Santa Cruz Harbor. \$24,000. 1989 Catalina 34 in excellent condition. Lower harbor. Full access. Great partners. (559) 312-5550, (559) 855-8277 or ark4021@gmail.com.

**J/120 PARTNERSHIP.** South Beach Marina, San Francisco. 50% equity ownership. Excellent condition 1998. Great sailboat for Bay racing and/or family cruising. Fully equipped with racing and cruising inventory. Great location next to AT&T Park. Serious buyers only. (650) 477-7905 or mcbowman@pacbell.net.

**SAIL THE BAY BARGAIN.** 1/3 deeded partnership in Catalina 27, berthed at Treasure Island, 200 hr. on new Yanmar diesel, new bottom paint, 3 jibs, reefable main, whisker pole, well equipped. 1/3 use, will train, \$4,000, share monthly expenses. (415) 282-0875.

**BENETEAU 393 PARTNERSHIP.** Sausalito. \$500. Clean, well maintained fast cruiser. Upgraded interior, winches, prop, diesel, full electronics, classic main, fully equipped. Qtr usage non-equity; may consider 1/8 or equity arrangement or sale. <http://marigotgroup.com/strider>. (415) 332-4401, (415) 331-4900 or 393@marigotgroup.com.



**42-FT SAILBOAT** in Bahamas/Caribbean. I'm offering partial ownership shares in my very well-equipped Hunter Passage 42 CC, currently located in the Bahamas. Co-owners may sail it there or may take it down into the Caribbean. \$40K for 1/4 ownership (3 consecutive months' usage each year) or \$70K for 1/2 ownership (6 consecutive months' usage each year). See the following website for more info. <http://sites.google.com/site/hendrickssailing>. (801) 792-1421 or DougHndrx@gmail.com.

**PARTNER/S FOR SOUTH OF BORDER.** San Rafael. Brewer ketch 45'- project for (time-share Mexico Cent/Am). Need partner/s in LLC. Solid boat, needs TLC. (512) 358-0031 or telebob@gmail.com.

**SAGA 409 SAILBOAT PARTNERSHIP.** Belvedere, CA. Equity ownership interest in new Saga 409 cruising sloop berthed at San Francisco Yacht Club. Semi-custom Tony Castro design built by Westerly Marine. Dual staterooms, separate stall shower, Vacuflush, Garmin chartplotter, flat screen TV, stereo, microwave, wine cellar. Spectra full-batten main with Doyle Stack Pack and lazy jacks, roller furling jib, electric halyard/mainsheet winch, Yanmar diesel, 3-blade folding prop, much more. Fast, easy to sail, great for entertaining. \$150K plus \$200/mo. (415) 298-2080 or george@kiwi-properties.com.



**SOUTH OF THE BORDER**



**PLAN YOUR MEXICAN GETAWAY NOW.** at the brand-new, gorgeous Cielo Y Mar condos. Located in Punta Mita, 35 minutes from Puerto Vallarta, available to rent from private owner. On the beach, 10 feet from the water, they offer spectacular views of ocean and mountains, the biggest infinity pool in the area, an endless beach, great surf breaks, great fishing, tremendous views of whales, bird life and the islands. While uncrowded and tranquil, just a five-minute walk to several waterfront restaurants. Choose from a spacious, beautifully furnished one or three-bedroom unit, or an amazing two-story penthouse with lovely shade trellis on the top floor. To reserve, call: Dona de Mallorca at (415) 599-5012. See details: [www.puntamitabeachfrontcondos.com](http://www.puntamitabeachfrontcondos.com).



**CHARTER DIRECT & SAVE \$\$\$\$.** Owner's time available for discount charter. Beautiful Robertson & Caine 4600 cat, *Hope*, featured in *Latitude 38*. Based in beautiful Belize. Book direct and save big bucks. [pettyd@comcast.net](mailto:pettyd@comcast.net).

**SailTime: The Hassle Free Alternative to Boat Ownership**

Join SailTime for a non-equity membership on our 2011 Hunter 36 – no hidden fees – just \$695 a month.  
**www.SailTime.com • (415) 869-2861**

**Offshore/Coast Passagemaking Mexico 2010-11 • Leg 1-Baja Ha-Ha**  
Learn passagemaking and cruising skills from sailing veteran: daily hands on participation in instruction material, sailing drills and safety checks. Captain references w/combined 85 years experience. 805-481-4567  
**Instruction / Itinerary / Package Details • www.cruisingexpeditions.com**





**VALLARTA CATAMARAN CHARTER.** Puerto Vallarta. Low season rates! Come sail with us on famous *HumuHumu* in perfect Banderas Bay conditions. Full day, Long Weekend or Costa Alegre Discovery Cruise. Vallarta has it all! [www.catpv.com](http://www.catpv.com). (760) 681-7825 or (760) 975-5850 or [info@catpv.com](mailto:info@catpv.com).



**OFFSHORE/COASTAL** Passagemaking Instruction. Build passagemaking and cruising skills. Captain ref. w/combined 85 years experience. Limited sailing experience OK, eagerness to get involved, understanding you're on an adventure, safety of the boat and your fellow crew members comes first. See more at [www.cruisingexpeditions.com](http://www.cruisingexpeditions.com). (805) 481-4567.

## TRADE

**MOVING TO CARIBBEAN!** Arizona. \$400,000. Looking to trade/sell 3+ year-old successful cigar lounge/business worth \$400K in Arizona for a 38-ft or larger sailboat. Ready to start new chapter in our lives. Serious inquiries only. [www.BigSticksFineCigars.com](http://www.BigSticksFineCigars.com). (602) 810-1665 or [trade@bigsticksfinecigars.com](mailto:trade@bigsticksfinecigars.com).

**TRADE FOR BOAT WORK.** and/or slip fees. Sailing Monterey. \$Negotiable. Trade sailing with or w/o lessons. Crealock 37 in Monterey for boat work and/or slip fees. [ddatpbio@gmail.com](mailto:ddatpbio@gmail.com).

**TRADE PROPERTY** for cruising sailboat 32ft-larger. Two lots in Clearlake: 1) view lot in Kono Tayee, utilities paved road, etc. Appraised 1990 @ \$19,900. 2) lot on the shoreline, suitable for dock. Appraised 1994 @ \$8,800. Copy of appraisals on request. [carlo@surewest.net](mailto:carlo@surewest.net).



## GEAR

**PRO FURL MODEL B35M \$1,000/OBO.** Pro Furl Model B35M with seven lengths of foil. Excellent condition. (209) 223-2183 or [oannio@comcast.net](mailto:oannio@comcast.net).

**AUTOPROP FEATHERING PROP.** Chamanche. \$2,000/obo. Model H5-470, in mint condition, suitable for Beneteau, Catalina, Jeanneau, Hunter, Caliber, or other sail boats of about 40-ft. Check [www.ab-marine.com](http://www.ab-marine.com) for suitability for your boat. [www.ab-marine.com](http://www.ab-marine.com). (209) 223-2183 or [oannio@comcast.net](mailto:oannio@comcast.net).

**NEW: PARATECH15, FIORENTINO12.9.** Paranchors-Drogues. Windvane wheeladapter, storm jibs, folding mast steps, Mastmate, MOM8, Blipper. Lift-crane: Forespar Motormate/ Cargomate-Garhauer. Walker tafflog, Drivesaver, rigid boomvang, windlasses, Force10 keroheater, Avon motor bracket, solar, inverters, Dometic 3way, anchors, headsails, Davis sextant, winches: Arco40s, Southcoast. (415) 497-3731 or [brad-low@sbcglobal.net](mailto:brad-low@sbcglobal.net).

**YANMAR 50 HP DIESEL ENGINE 4JH2E.** Santa Cruz. \$2,000. 1997 engine in Catalina 42. In running condition for testing and inspection. Strong four-cylinder engine that starts easily, no smoking or overheating. Gear box (KM4A) not working. (831) 685-8823 or [danasc40@sbcglobal.net](mailto:danasc40@sbcglobal.net).

**BIG RIG MAST AND BOOM.** Costa Mesa. \$10,000. Mast 79' 2" length, heavy wall. Oval section 14"x10.5" tapers to 9.5". Includes 4 sails and 30-ft boom. Includes shrouds, stays and Hood furling. Excellent condition. (949) 548-4192 or [minneys@aol.com](mailto:minneys@aol.com).

**74-FT MAST.** designed for catamaran. Best offer. (415) 269-5165.

**UNIVERSAL M25XPB 26HP.** diesel in-board. Seattle area. \$5,000. Like new-149 hours. Currently installed in my sailboat in Winslow Wharf Marina (Bainbridge Island). Come see it run. Includes prop, shaft, panel, fuel filter, cooling system, throttle/shift control. \$5,000 FIRM or trade toward 30'+ 5th wheel/travel trailer. (360) 643-9113 or [jn5289@yahoo.com](mailto:jn5289@yahoo.com).

**52' PEARSON 37 MAST.,** rigging and sails. Monterey/Pacific Grove. \$Best offer. The sails and rigging are unused, and the mast is in fine condition. Mast size is 8" x5 1/2". (831) 649-1249 or (831) 419-1051 or [loomis15885@att.net](mailto:loomis15885@att.net).

**SAIL COVERS.** Loch Lomond Marina, San Rafael. \$800/obo. Sail covers - Pacific/aqua blue - brand new for 14' 4" main boom and 10' mizzen boom. Never been on boat. (415) 302-9841 or (415) 342-2508, 110 Loch Lomond Drive or email [chriscoykendall@att.net](mailto:chriscoykendall@att.net).

## MISCELLANEOUS

**TEAK WOOD DECKING FROM BURMA.** Magalia, CA. Best offer. Teak decking Burmese old growth, not plantation. Bought Oct. 1981 from American Marine Singapore. Builders of Grand Banks Yachts. Invoice shows 629 bd' 134 at 12', approx 2081' 11/2"x9/16" finished 4 sides, with 1/4x1/4 notch cut in. Kept inside and dry, like new. Have original paperwork. Selling as one unit \$9,000/obo. 44 books, authors: Hayden, Hal Roth, Donald Street, Williams, Hiscok. (530) 873-1179, (530) 873-7086 or [hudolo@yahoo.com](mailto:hudolo@yahoo.com).

## CLUBS & MEMBERSHIPS

**SINGLE SKIPPERS AND CREW** of all abilities are invited to join the Single Sailors Association. Membership includes daysailing, raft-ups, invaluable onboard training, social events. Meetings held 2nd Thursday, Ballena Bay Yacht Club, [www.bbvc.org](http://www.bbvc.org). Social; 6:30 pm. Meeting; 7:30 pm. Guests welcome. More info at [www.singlesailors.org](http://www.singlesailors.org). (510) 233-1064.

## PROPERTY SALE/RENT



**HOME FOR RENT** with deep water berth, Alameda. \$3,150. 3 bedroom 2 1/2 bath home on the water with private 36-ft boat dock plus dinghy dock. Views of the San Francisco Bay from every room. Spacious and open, approx 2300 sq feet of living space with cathedral ceilings and filled with bright natural light. Huge master bedroom suite with private upper deck overlooking the Bay. Private gate entry with direct access to your boat. Quick access to San Francisco. Attached two-car garage plus plenty of off-street parking, laundry room, large kitchen with breakfast area. This home also may be made available furnished. Must see! More at <http://picasaweb.google.com/SumaLandscaping/BallenaBest?authkey=Gv1sRgCIH42v2yutqW8wE&feat=directlin>. (510) 421-8000 or [susanfrank@comcast.net](mailto:susanfrank@comcast.net).



**WORKING WATERFRONT OFFICE(S).** Pt. Richmond. \$1,000/month. Timberwharf Office(s): Overlooking Santa Fe Canal and the KKMI Marina. 1,000 square feet, easily divided. Includes two private restrooms. \$1,000 per month plus utilities. Contact Paul Kaplan: [www.kkmi.com](http://www.kkmi.com). (510) 235-5564 or [paul@kkmi.com](mailto:paul@kkmi.com).

**AMERICAN SAILOR SELLING.** harbour-side home. Whangarei, New Zealand. \$US 400,000 FIRM. Fully-furnished home, pool, gardens overlooking harbour in the Onerahi suburb of Whangarei - a major re-outfitting port in Northland New Zealand. Extensive SW Pacific and Kiwi cruising community with spectacular local sailing. Intermittently lived NZ 40 years - ten in house - now at age 72 simplifying life and moving back aboard our one-off 40' Kauri cutter on marina. Website for details and 130 Flickr photos: [www.americankiwihome.com](http://www.americankiwihome.com). (303) 494-3154 or [neptune@ecentral.com](mailto:neptune@ecentral.com).



**BOATERS PARADISE.** St. Petersburg, FL. Extraordinary views, 237' on deep water. 3BR, 3.5BA, huge garage and workshop, big lot, dock 100', boat lift, cul-de-sac. Minutes to Gulf of Mexico, 45 minutes to Tampa airport. For full details, Google MLS 7472362. (727) 698-3000 or [hercomesthesun8888@yahoo.com](mailto:hercomesthesun8888@yahoo.com).

## BERTHS & SLIPS

**EMERY COVE MARINA.** 45-FT slip for sale. Emeryville. \$39,900. 45-ft downwind slip at the end of B dock for sale. Easy access to the Bay in the best marina in the area. Priced to sell. [rojbrown@me.com](mailto:rojbrown@me.com).

**50-FT PRIME SLIP PIER 39, SF** \$46,000. F-Dock, Slip 11, east side. Protected from wind. Close to gangway, showers and marina office. Covered parking across street with special rates for owners. (559) 355-6572 or [scorch@tempest-edge.com](mailto:scorch@tempest-edge.com).

**36' SLIP, SF PIER 39 \$8,750.** "C" Dock, Slip 26. Marina offers special parking privileges at Pier 39 garage. (831) 624-4910 or [ted@twjohnston.com](mailto:ted@twjohnston.com).

## MARINE ENGINE CO.

Complete Engine Services • Gas & Diesel  
30 Years Experience • Reasonable Rates  
Tune-Ups • Oil Changes • Engine Rebuilding, etc.  
(415) 332-0455

**For the best - and most exposure - of your classified ad...**  
submit your ad safely online at: [www.latitude38.com](http://www.latitude38.com).

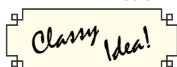

Your ad will be posted online within two business days, appear in the next issue of the magazine, and remain online until the following issue is released.



## Get the Reliable, Powerful Wheel Pilot

Quiet & Dependable • Affordable • Built for Immersion  
Easy Owner Installation • Low Power Consumption  
831-687-0541 [www.cptautopilot.com](http://www.cptautopilot.com)

## YOGA FOR SAILORS ON THE WATERFRONT

Gentle yoga class at Oakland YC Saturdays 8-9 am starting Sept. 4. Beginners welcome! Donation-based; all proceeds benefit Alameda Food Bank. See [www.bowoyoga.com](http://www.bowoyoga.com). [yogaforu2009@gmail.com](mailto:yogaforu2009@gmail.com), (415) 785-4530, (510) 333-8846



# GOLDEN STATE DIESEL MARINE

PARTS  
YANMAR • UNIVERSAL • WESTERBEKE  
PERKINS • ISUZU • PATHFINDER • ATOMIC 4

SERVICE  
DIESEL ENGINES

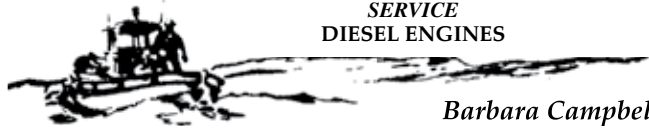

Barbara Campbell

351 EMBARCADERO  
OAKLAND, CA 94606

(510) 465-1093

Oil Paintings  
by  
Ian Wilson-Dick

Open Studio  
October 9-10 & 16-17  
or by appointment  
Visit our new studio in  
Petaluma, California  
(707) 769-9588



[www.ianwilson-dick.com](http://www.ianwilson-dick.com)



**1,000 Used Sails  
Listed at  
[minneysyachtsurplus.com](http://minneysyachtsurplus.com)**

**We Buy Good Used Sails  
and Marine Equipment**

**MINNEY'S YACHT SURPLUS**

1500 Newport Bl., Costa Mesa, CA  
949-548-4192 • [minneys@aol.com](mailto:minneys@aol.com)

*"We keep boating affordable!"*

## KATADYN SURVIVOR 35 WATERMAKER

The Survivor is a must for all sea-going vessels and is the most widely used emergency desalinator. It is used by the U.S. and international forces. It is able to produce 4.5 liters of drinkable water per hour. These are unused U.S. government surplus.

Reconditioned by Katadyn **\$950.**  
Compare to factory new price: \$1,995.

For more information or  
to place an order, please  
call one of our sales reps.

Equipment Parts Sales  
In the U.S.: (800) 417-2279  
Outside the U.S.: (717) 896-9110



## CREW

**80-FT SCHOONER.** Leaving For Mexico Mid-November. Destination Puerto Vallarta. Captain seeking several passengers/crew. Experience the adventure of a lifetime. For details contact: [phschrtiama@hotmail.com](mailto:phschrtiama@hotmail.com).

## PERSONALS

**SEEKING SAILMATE.** Very attractive lady, slender, great figure, smart, 60, Sonoma County, loves sailing. Former boat owner desires fun, interesting, sexy man for possible LTR. Love nature, cooking, reading, music, dancing, very liberal worldview. Have sight deficit but not to worry. [gardenia@sonic.net](mailto:gardenia@sonic.net).

## JOBS WANTED

**CARETAKER.** Pets, garden, family, and project manager while you're cruising or racing. Bilingual educator, arborist, native of Marin, non-smoker. References. Call Marlaina. (707) 951-3254 or email [aspenseer@yahoo.com](mailto:aspenseer@yahoo.com).

## JOB OPPORTUNITIES

**GOOD BOAT WORKER WANTED.** Trade for 50% ownership Cal 25. On trailer, we can locate conveniently. Finish boat for 1/2 title ownership. Hull, deck and rigging are restored. Have all deck hardware and equipment to finish. Need labor and completion effort to finish this boat. Have 3DL sail set and extra gear to make this a great boat. I need to work with a partner to finish it because I've taken work out of state and can't be present. Will work out a good partnership deal to go forward fairly. Just want to finish this project. I have the fabrication and support capability, I am looking for a facilitator partner. (408) 500-2038 or [hurricaneagain@yahoo.com](mailto:hurricaneagain@yahoo.com).

**BOAT SALES PERSON.** Work in a beautiful tropical environment - knowledge of power and sail is a necessity, good with people, friendly, comfortable office. Spanish and English is a big plus. Email [tropicaljob@gmail.com](mailto:tropicaljob@gmail.com).

**DOCK MAINTENANCE WORKER.** East Bay. Large East Bay marina is seeking a self-motivated dock maintenance worker. Ideal candidate will possess plumbing, electrical and carpentry skills. Boating experience a plus. Must be willing to work Sundays. Full time w/ benefits, salary DOQ. Fax resume to (415) 421-3167 or email [MarinaEstuary@yahoo.com](mailto:MarinaEstuary@yahoo.com).

## BUSINESS OPPORTUNITIES

**SAILS! SAILS! SAILS! SAILS!** Major sailmakers' California sales office/territory. Well established, low overhead, Grand Marina location. Owner retiring. Will train. Sailing experience, people skills a must. \$10K. Terms available. Fun part-time job for semi-retired sailor/sailorette. [leesailsnc@yahoo.com](mailto:leesailsnc@yahoo.com).

**EARN YOUR LIVING ON THE WATER!** Currently Servicing SF East Bay Area. Well-established and respected boat-based holding tank pumpout service with great clientele for sale. Excellent part-time income with real potential for growth. Turnkey operation includes 21' Boston Whaler Outrage, professionally-maintained 2005 Mercury 90hp four-stroke outboard and complete, top-of-the line onboard pumpout equipment, galvanized Pacific dual axle trailer and a very low-mileage 1996 Ford E-250 tow vehicle. Will sell all or part and will train. (925) 429-4490 or [matt@head-honcho.net](mailto:matt@head-honcho.net).



**STEARNS WHARF.** Charter Business. Santa Barbara Harbor. \$Best Offer. Seeking parties interested in operating a coastal cruising business from Stearns Wharf which may include gray whale watching, sunset cruises, dinner cruises, etc. Contact (805) 897-1969 or [Sriedman@SantaBarbaraCA.gov](mailto:Sriedman@SantaBarbaraCA.gov).



**NEED  
CASH  
FAST?**

Advertise your **USED MARINE GEAR**  
in our *Classy Classifieds*

**THIS STUFF SELLS FAST!**

Deadline is the 18th at 5pm. See page 168 for details.

Bay Racing...  
Where the action is!

2011 RACING  
IS COMING  
*FAST!*



Plan to promote in *Latitude 38's*  
**2011 Northern California**  
**SAILING CALENDAR**

For more information contact: [john@latitude38.com](mailto:john@latitude38.com) or [shawn@latitude38.com](mailto:shawn@latitude38.com)

# JUST YOU AND THE SEA...

...and the jacuzzi,  
the 80-ft long pool, the surf,  
the Punta Mita anchorage, and the 4-mile distant  
Tres Marietas Islands

## Punta Mita Beachfront Condos

*Call Doña de Mallorca for reservations!*

**1.415.599.5012**

**[www.puntamitabeachfrontcondos.com](http://www.puntamitabeachfrontcondos.com)**

## ADVERTISERS' INDEX

AB Marine..... 60	Blue Pelican ..... 176	Davis Instruments..... 148	Golden State Diesel Marine 178	KKMI - Full Service Boatyard ..... 188
Adventure Cat Charters ..... 26	Blue Sky Energy ..... 122	DeWitt Studio ..... 181	Grand Marina ..... 2	KKMI - Rigging ..... 36
Islander 36 Fleet ..... 138	Blue Water Yacht Insurance.. 56	Diesel Fuel Filtering ..... 149	Hansen Rigging ..... 63	KKMI - Systems/Electronics .. 48
Almar Marinas ..... 51	Bluerush Boardsports ..... 141	Downwind Marine..... 24	Harbor Island West Marina..... 163	Landing School, The ..... 147
Alpenglow Marine Lights ... 170	Bluewater Network..... 174	Doyle Sails ..... 25	Harken ..... 14	Larry R. Mayne Yacht & Ship Broker ..... 10
American Battery ..... 149	Boat Yard at Grand Marina, The ..... 21	Easom Rigging..... 103	Helms Yacht & Ship Brokers/ West Coast Multihulls ..... 182	Lee Sails ..... 149
Bacon Sails & Marine Supplies ..... 63	Boatswain's Locker ..... 31	El Salvador Rally/ Bahia del Sol ..... 35	Helmut's Marine Service..... 73	List Marine Enterprises ..... 20
Baja Ha-Ha Beach Party .... 121	Bottom Siders..... 170	Emery Cove Yacht Harbor.... 67	Heritage Marine Insurance... 70	Loch Lomond Marina ..... 149
Baja Ha-Ha Sponsors ..... 123, 124, 125	Brisbane Marina ..... 65	Emeryville Marina ..... 165	Heritage Yacht Sales..... 185	Lunasea Lighting ..... 148
Ballenger Spars..... 67	BVI Yacht Charters..... 144	Equipment Parts Sales..... 178	Hidden Harbor Marina..... 77	Mack Sails..... 8
Bay Area Boat Works ..... 62	Cal Maritime Academy..... 139	Essex Credit Corp..... 46	Hogin Sails..... 50	Makela Boatworks..... 172
Bay Island Yachts ..... 8	Call Of The Sea ..... 144	Euro Marine Trading ..... 75	Hood Sails..... 43	Marina Bay Yacht Harbor .... 37
Bay Marine Boatworks..... 53	CDI/Cruising Design ..... 75	Fago, Margaret Artist..... 72	Hotel Coral & Marina ..... 164	Marina de la Paz ..... 120
Bay Marine Diesel..... 172	City Yachts..... 11	Farallone Yacht Sales..... 6, 7	Hotwire Enterprises..... 172	Marina El Cid ..... 118
Bayside Canvas ..... 69	Coast Marine..... 78	Ferreteria Zaragoza ..... 167	Hydrovane..... 118	Marina Mazatlan ..... 49
Bellhaven Yacht Sales & Charters..... 146	Costa Baja Resort & Marina..... 45	Flying Cloud Yachts ..... 184	Ian Wilson-Dick, Artist..... 178	Marina Nuevo Vallarta ..... 42
Berkeley Marina..... 29	Cover Craft..... 70	Forespar..... 69	John Beery Yachts ..... 183	Marina Puesta Del Sol ..... 166
Berkeley Marine Center ..... 129	Coyote Point Marina..... 47	Fortman Marina..... 71	Katadyn ..... 108	Marina Riviera Nayarit..... 34
Beta Marine Engines..... 71	Cruising Yachts ..... 9	Garhauer Marine..... 39	Kissinger Canvas..... 129	Marina Village..... 33
	CYOA Yacht Charters..... 145	Gentry's Kona Marina ..... 167	KKMI - Brokerage..... 184	Marine Lube ..... 149
		Gianola Canvas Products... 147		



*Jim DeWitt is 80! He's looking great!*

**deWitt**

**Join us in celebrating  
Jim DeWitt's 80<sup>th</sup> year!**

The entire month of November,  
we will be having a retrospective show  
of Jim's work through the years.

A reception to visit with Jim  
and view the art collection will be held  
Thursday, November 18 • 5:30-8 p.m.

**DeWitt Art Gallery & Framing**

121 Park Place, Point Richmond, CA 94801

(510) 236-1401 • (800) 758-4291

[www.jimdewitt.com](http://www.jimdewitt.com)

[www.dewittgalleryandframing.com](http://www.dewittgalleryandframing.com)

Wednesday-Saturday 11:00-7:00

Sunday 9:30-5:30

## ADVERTISERS' INDEX *cont'd*

Marine Outboard Co..... 52	North Direct Sails..... 73	Quantum Pacific..... 19	South Beach Harbor ..... 54	Vessel Electric..... 176
Mariner's General Insurance ..... 160	North Sails - San Francisco .. 79	Quickline..... 68	South Beach Riggers..... 55	Voyager Marine..... 77
Maritime Institute..... 74	Opequimar Marine Center..... 166	Raiatea Carenage Services ..... 161	Spud Point Marina ..... 114	W.D. Schock Corp. .... 65
Marotta Yachts ..... 186	Orange Coast College..... 57	Remote Satellite Systems .... 119	Sta-Lok Terminals ..... 20	weatherguy.com..... 167
Mathiesen Marine ..... 174	Outboard Motor Shop..... 79	Richardson Bay Marina ..... 75	Starbuck Canvas ..... 8	Wedlock, Ramsay & Whiting Marine Surveyors ..... 174
Mazatlan Marine Center / La Paz Yachts..... 13	Owl Harbor Marina ..... 128	Rooster Sails ..... 77	Surveyor - Jesse Brody..... 170	West Marine..... 28, 30, 59
McDermot Costa Insurance .. 72	Oyster Cove Marina ..... 167	Sail California..... 16, 17	Svendsen's Boat Works ..... 23	West Marine - Rigging..... 64
McGinnis Insurance..... 68	Oyster Point Marina ..... 79	Sail Warehouse, The ..... 172	Svendsen's Marine ..... 40	Westpoint Harbor..... 58
McGrath Yachts..... 15	Pacific Crest Canvas ..... 63	Sailrite Kits ..... 18	The Dinghy Doctor ..... 78	Westwind Precision Details... 55
Mettec, Inc..... 67	Pacific Rigging ..... 74	Sal's Inflatable Services..... 76	TMM Yacht Charters..... 145	Whale Point Marine Supply ..... 38
Michael Wiest Yacht Sales . 183	Pacific Yacht Imports..... 12	Salt Harbor Studio..... 76	Trident Funding ..... 4	White, Chris Designs ..... 176
Milltech Marine Inc..... 44	Pantaenius America, Inc. ... 174	San Francisco Boat Works . 140	Ullman Sails..... 120	WinchRite / Sailology ..... 66
Minney's Yacht Surplus ..... 178	Paradise Village..... 61	Sausalito Marine Electrical Shop..... 73	Vallejo Marina ..... 146	Yachtfinders/Windseakers ... 10
Modern Sailing School & Club ..... 27	Passage Yachts..... 5	Scanmar International ..... 32	Variprop USA ..... 69	
Napa Valley Marina Yachts 182	Pettit Paint..... 41	Schoonmaker Point Marina .. 22	Ventura Harbor Boatyard... 164	
Nickle Atlantic/ Froli Sleep Systems..... 176	Pier 39 Marina ..... 109	Sea Frost ..... 66		
Norpac Yachts ..... 187	Pineapple Sails ..... 3	Seashine..... 129		
North Beach Marine Canvas ..... 55	Pirate's Lair ..... 102	Seatech ..... 170		
	Pittsburg Marina ..... 162	Shadetree Fabric Shelter ..... 71		
	Punta Mita Beachfront Condos ..... 180			



# M U L T I H U L L S



**SEAWIND 1160** Call us about charter test sail.



**CHRIS WHITE HAMMERHEAD 54**



**PDQ 32 ALTAIR**  
Two boats from \$139,000.



**CORSAIR 24 MKII**  
\$34,000.



**GEMINI 105M**  
\$124,000.



**36' SEAWIND 1000XL, 2001**  
Two boats from \$169,000.



**CORSAIR SPRINT 750**  
2 starting at \$49,500.



**31' CORSAIR, 1998**  
\$105,000.



Dealer for Seawind Catamarans  
and Corsair Trimarans

[www.helmsyacht.com](http://www.helmsyacht.com)  
**(510) 865-2511**



**CORSAIR 28CC, 2005**  
\$89,900.  
Corsair 28AC, 1998  
\$59,000.

## SERVING THE BOATING COMMUNITY SINCE 1957



**37' ISLANDER SLOOP**  
1968 • \$21,900



**32' CORONADO AFT CABIN**  
1973 • \$19,950



**35' AMUTHON STEEL SLOOP**  
1966 • \$18,500



**56' FOUNTAINE PAJOT MARQUISES**  
2001 • \$595,000



**44' SIRENA**  
1988 • \$109,000



**36' BENETEAU 361**  
1999 • \$89,500



**45' C&L EXPLORER CUTTER**  
1979 • \$59,500



**47' COLIN ARCHER STEEL PH KETCH** • 1972 • \$69,500



**39' PEARSON 390 CENTER COCKPIT** • 1972 • \$32,500



**40' NEWPORTER STAYSAIL SCHOONER** • 1957 • \$29,500



**48' C&C PH CUTTER**  
1982 • \$95,000

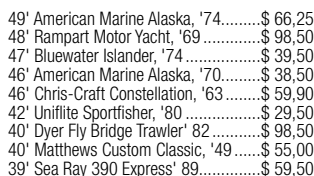

- 49' American Marine Alaska, '74.....\$ 66,250
- 48' Rampart Motor Yacht, '69.....\$ 98,500
- 47' Bluewater Islander, '74.....\$ 39,500
- 46' American Marine Alaska, '70.....\$ 38,500
- 46' Chris-Craft Constellation, '63.....\$ 59,900
- 42' Uniflite Sportfisher, '80.....\$ 29,500
- 40' Dyer Fly Bridge Trawler' 82.....\$ 98,500
- 40' Matthews Custom Classic, '49.....\$ 55,000
- 39' Sea Ray 390 Express' 89.....\$ 59,500
- 39' Sea Ray 390 Express, '89.....\$ 49,500
- 38' Chris-Craft 382 Commander '85...\$ 89,500
- 30' Chris-Craft, '68.....\$ 6,200



## NAPA VALLEY MARINA YACHTS

**(866) 363-8882 • (707) 252-8011**

1200 Milton Road • Napa, CA 94559

[www.napavalleymarina.com](http://www.napavalleymarina.com)

Marina • Boatyard • Chandlery • Brokerage

Dealers for  
**YANMAR**

**Interlux**  
yachtpaint.com

Distributors for *Brownell*  
Boat Stands

# Michael Wiest Yacht Sales

## QUALITY PRE-OWNED SAILBOATS



51' BENETEAU 510, '92..... \$189,000



49' BENETEAU SLOOP, '07..... \$445,000



47' SORENSEN CELERE, '88... \$359,000



45' MORGAN STARRATT, '79 .... \$49,000



44' SWAN, '74..... \$125,000



44' HUNTER ..... CALL



44' TARTAN 4475, '75..... \$79,000



43' IRWIN MkII, '88 ..... \$119,900



42' HUNTER PASSAGE, '95..... \$99,000



40' BAVARIA SLOOP, '01 ..... \$179,000



36' BENETEAU 361, '00..... \$99,500



36' HUNTER 356, '03..... \$99,500



33' HUNTER SLOOP, '91 ..... \$39,500



32' CATALINA 320, '98 ..... \$65,000

CHECK THEM OUT AT

[www.michaelwiestyachtsales.com](http://www.michaelwiestyachtsales.com)

then call

**(510) 601-5010**

Emeryville, CA

# JOHN BEERY YACHTS

Welcomes

## DICK MAY

Dick has returned to the Bay Area to offer his 40 years of experience selling new and used sailboats to Northern California



*Dick May and John Beery*

sailors. He has unmatched experience and product knowledge, giving the buyer or seller a distinct advantage when trading up or finding that perfect boat.

## John Beery Yachts

*Originally established in 1958*

John Beery Yachts has helped thousands of sailors buy, sell and learn to sail on San Francisco Bay. Founder John Beery is recognized for both his sailing and business success.

*For first class service,  
list your boat with John Beery Yachts*

### Featured Brokerage



**42' Valiant, 2003**

The ultimate blue-water cruiser in immaculate condition.

Cal 31, 1979...\$17,500

Mariner Square, Alameda

**(510) 521-2727**

*For more information and listings,  
please visit:*

[www.johnbeeryyachts.com](http://www.johnbeeryyachts.com)

Dick May • Kenn Wright  
Rosivaldo Rocha



# Flying Cloud Yachts



**Hans Christian** **GEMINI**

6400 Marina Drive  
Long Beach, CA 90803

Sail • BROKERS • Power  
www.yachtworld.com/fcyachts  
flyingcloud@verizon.net

Phone (562) 594-9716  
Fax (562) 594-0710



**BENETEAU 473, '05 \$265,000**



**46' HYLAS, '06 \$595,000**

## TWO CATALINA 380s



2001 Hard Dodger,  
LOADED! \$140,000  
1998 Real nice! \$115,000



**43' TASWELL, '89 \$259,000**



**36' HUNTER, '05 ~~\$124,900~~ \$109,500**



**37' CF SLOOP, '78 \$24,900**



**38' HANS CHRISTIAN, '86 \$149,500**



**IRWIN 42, '77 \$59,500**



**47' GILS CATAMARAN, '02 Make Offer**



**GEMINI CATAMARANS, 4 from \$49,900**



**42' CATALINA, '93 ~~\$118,000~~ \$109,000**

APPROX. 100 LISTINGS ON OUR WEB SITE: [www.flyingcloudyachts.com](http://www.flyingcloudyachts.com)



## Maritime Yacht Brokerage

**(510) 236-6633 • fax: (510) 231-2355**  
**yachtsales@kkmi.com • www.kkmi.com**  
**530 W. Cutting Blvd., Pt. Richmond, CA 94804**

LIST WITH US! Ask us  
about our Maritime  
Protection Program



**SWAN 40** (1996) Frers design, exceptionally well maintained, 2-cabin performance cruiser. Awl-grip Flag Blue hull, comprehensive sail inventory, and full in-slip cover. Asking \$299,000



**HINCKLEY BERMUDA 40 MkII Yawl CB** (1968) Bill Tripp design is highly regarded for classic beauty, superb workmanship and quality details. New sails, dodger, intelligently updated. Excellent condition. Asking \$147,000



**LITTLE HARBOR 51** (1996) Very comfortable Ted Hood designed pilothouse with full stand-up headroom and 360° visibility. Set up for shorthanded sailing and superbly maintained by an experienced owner. Asking \$619,000



**JARVIS NEWMAN 36** (1978) Classic flybridge 'lobster boat' of Maine build quality. Single engine (160 hours), queen V-berth with enclosed head. Excellent condition, well maintained and lightly used. Asking \$129,000



**SWAN 45** (2003) Race or cruise. *Rancho Deluxe* won her class in the TransPac and was second twice in the Big Boat Series. This boat has all the gear to go cruising and is in perfect condition. \$525,000



**BALTIC 42 DP** (1984) Since 1973, Baltic Yachts of Finland have been building comfortable, safe, long distance cruisers with very good sailing and performance characteristics. Doug Peterson design, superbly maintained, hull #29. Asking \$165,000



**NELSON MAREK CUSTOM A** 92-ft aluminum world cruiser. Recently repowered. Immaculate throughout and in perfect condition. \$1,500,000



# HERITAGE

Yacht Sales

*Live your Dreams*



Long Beach-Naples  
Newport Beach  
Wilmington

231 North Marina Dr. 866-569-2248  
829 Harbor Island Dr. 877-389-2248  
Berth 202 Peninsula Rd. 877-599-2248  
Cell. 310-995-9989

[www.heritageyachts.com](http://www.heritageyachts.com)

## FEATURED LISTING

46' HYLAS  
2006  
LA HARBOR  
\$599,500



SISTERSHIP

65' MacGregor  
PH 1994  
\$220,000



50' Garden Steel  
Ketch 1969  
\$149,000



49' Transpac  
1984  
\$189,900



45' Hunter Legend  
1986  
\$79,000



40' Catalina  
1998  
\$129,000



38' Downeast  
1979  
\$49,000



## YOUR SOUTHERN CALIFORNIA ALERION EXPRESS DEALER

33' Alerion Express  
2011



28' Alerion Express  
2011





# Marotta Yachts of Sausalito

Brokers of Fine Sail and Motor Yachts

415-331-6200 • info@marottayachts.com • www.marottayachts.com

See at: [www.marottayachts.com](http://www.marottayachts.com)



**50' STEPHENS, 1966** Stephens were all expensive custom builds and this is a prime example. Over \$500k spent on her since '04; updated inside/out but retains her original stately lines and elegant ambiance. Possible Sausalito transferable slip. **\$227,000**

See at: [www.marottayachts.com](http://www.marottayachts.com)



**41' SCEPTRE RAISED CABINTOP CUTTER, 1985** Professionally maintained local boat shows VERY nicely inside and out. Leisure Furl in-boom system w/Hood main, Harken roller furler and 105% Hood jib, updated electronics, more. **\$195,000**

See at: [www.marottayachts.com](http://www.marottayachts.com)



**40' BENEteau FIRST 40.7, 2003** The First 40.7 combines the excitement of a sleek racer with all the comforts of a luxurious cruiser. This one is a well-equipped beauty that shows new inside and out. She's the deep version (preferable for the Bay). **\$169,000**

See at: [www.marottayachts.com](http://www.marottayachts.com)



**43' HANS CHRISTIAN, 1978** Classic offered for sale by original owner. New teak decks (this was a \$40,000 job alone!), Awlgrippd hull, updated interior, optional larger diesel and Telstar performance keel. **\$159,000**

See at: [www.marottayachts.com](http://www.marottayachts.com)



**37' HUNTER 376, 1999** Very spacious, light and airy, this vessel shows as new; must see to appreciate. Out-of-country owners motivated; offers encouraged. Sausalito Yacht Harbor slip can be arranged. **\$97,000**

See at: [www.marottayachts.com](http://www.marottayachts.com)



**48' C&C LANDFALL CUTTER, 1980** Landfall is C&C's first large boat w/emphasis on cruising. This one is a spacious 3-cabin, 2-head cutter that's VERY competitively priced and lying in a transferable Sausalito slip. Motivated owner is encouraging offers. **\$89,000**

See at: [www.marottayachts.com](http://www.marottayachts.com)



**32' CATALINA 320, 1998** Very clean (down below shows as new) and well fit out (chartplotter, AP, heat/AC, dodger, bimini, etc.) deep draft model that's competitively priced and lying in a transferable Sausalito slip – a nice turn key package! **\$74,950**

See at: [www.marottayachts.com](http://www.marottayachts.com)



**41' MORGAN OUT ISLAND, 1979** Center cockpit ketch. Never cruised and fresh water kept, she shows much newer than actual age. Note all new stainless steel ports. **\$64,000**, offers encouraged.

See at: [www.marottayachts.com](http://www.marottayachts.com)



**38' INGRID SLOOP, 1984** Clean, never cruised, one owner example of this classic John Atkins design. A modern adaptation of pilot boats designed by Colin Archer for North Sea conditions, the Ingrid is the gold standard for capable cruisers. **\$59,000/Offers**

See at: [www.marottayachts.com](http://www.marottayachts.com)



**36' UNION CUTTER, 1980** Heavily built full keel canoe sterned classic, designed by Robert Perry and built by the renowned Union yard in Taiwan. Repowered, aluminum mast, rerigged. Offers encouraged. Competitively priced at **\$59,000**

See at: [www.marottayachts.com](http://www.marottayachts.com)



**38' C&C, 1980** C&C is known for producing fast, good looking and well built boats, and this is a prime example: she shows very nicely (especially her oiled Burma teak interior), is competitively priced and sails like a witch – a very nice combination. **\$49,000**

See at: [www.marottayachts.com](http://www.marottayachts.com)



**38' MORGAN, 1981** Morgans are well known for quality construction and seaworthiness; high D/L ratio of 265 and long fin keel provide a comfortable ride in the Bay's boisterous conditions. Very clean in and out, with recent, dark blue Awlgrip. **\$45,000**

See at: [www.marottayachts.com](http://www.marottayachts.com)



**40' CHALLENGER KETCH, 1973** Recently Awlgrippd in beautiful Flag Blue, renewed brightwork, incredibly spacious below with 6'5" headroom. **\$43,500**

See at: [www.marottayachts.com](http://www.marottayachts.com)



**35' PEARSON SLOOP, 1981** Built in Rhode Island to typical Pearson standards, this is one of the last 35s built and has been a local boat since 1983. In very nice shape, priced right and lying in a transferable Sausalito Yacht Harbor slip. A nice package! **\$35,000**

See at: [www.marottayachts.com](http://www.marottayachts.com)



**34' HUNTER, 1984** Very roomy 34-footer in nice shape with transferable Sausalito Yacht harbor slip. Note deep draft, Yanmar diesel, custom hard dodger, oversize winches, radar and chartplotter. Competitively priced by motivated owner. Offers encouraged. **\$24,900**

at 100 BAY STREET • SAUSALITO • CALIFORNIA 94965 since 1946

# NORPAC YACHTS

**We Are SELLING Our Boats & NEED MORE LISTINGS!**  
**THIS is the time: LIST YOUR BOAT with NORPAC!**

1150 Brickyard Cove Rd., B9, Pt. Richmond, CA 94801

(510) 232-7200 • FAX (510) 232-7202

email: info@norpacyachts.com

FOR MORE  
SEE OUR

norpacyachts.com

WEBSITE

Offers Encouraged



**39' BENETEAU 393 LIKE NEW!** Light use. Dsl, dodger, 2 private stms, 2 heads w/showers, furling, self-tailers, new genny, main, Pryde 95 & 150 jibs, wheel/pedestal, pulpits, inverter, full galley mid-ship, conv w/ settee/ship's table, ++ **\$149,950**



**41' CT-41.** Exquisite example of this revered Garden design w/many custom features. Fiberglass, big dsl, teak deck, cabin heat & fireplace, tiled shower & head, gorgeous interior, alum. spars, full galley, refrigeration & much MORE! MUST SEE... Asking **\$78,950**



**133' CAR FERRY** Conversion: Office/Studio. Ultra spacious. Fully operational. Set up for very comfortable living and working. Ice Class, built in Norway. Fine condition. Absolutely unique and VERY cool. Rare opportunity. **\$375,000**



**40' X-YACHTS X-119 SLOOP.** Famous Danish builder, racer-cruiser one design by Neils Jeppesen. Loaded with gear, radar, new Volvo Penta diesel in 2000 and MORE! Proven ocean winner in Melbourne-Osaka Race. Asking **\$109,000**



**48' DUTCH CANAL BARGE** by DeVries. STEEL. Unique cruising liveboard for Bay and Delta. Comfort and character. Diesel, tub, galley, fireplace, salon, convertible aft enclosure, beautiful decor, plus MORE! Asking **\$219,000** /Offers



**36' ISLANDER** Sloop. Well respected and outstandingly popular Alan Gurney design. Wheel steering, dsl, full dbl lineflines w/pulpits, modified fin w/skeg-hung rudder, self-tailers, rigged for short-handed sailing, furling, well laid out and comfortable down below. New trans, dodger and MORE! Asking **\$44,950**



**38' CLASSIC ENGLISH KETCH.** Award winning beauty, fine condition. Pitch pine over oak, copper riveted. Dsl, dodger, new teak decks, radar, gorgeous interior & MORE! **\$99,950**



**38' CLASSIC ENGLISH KETCH.** Award winning beauty, fine condition. Pitch pine over oak, copper riveted. Dsl, dodger, new teak decks, radar, gorgeous interior & MORE! **\$99,950**



**36' STEEL HARTOG KETCH.** Robust bluewater cruising doubled-ender, 1985. Low hours diesel, radar genset, air conditioning, watermaker, RIB and outboard, O/S liferaft, vane, wheel, pulpits, 2x course lifelines and MORE! GREAT BARGAIN on a go anywhere cruiser! Asking **\$49,950**



**101' STEEL TUG** in downtown Sausalito. This great YTB is operational, a fantastic opportunity with loads of potential! Bring your imagination, she's awesome, highly desirable & a fabulous value. Asking **\$44,950**

## Visit us at BEAUTIFUL & FRIENDLY Brickyard Cove Marina

**SAIL**  
100' MEGA SLOOP Custom Offshore Performance Cruiser. Comfort & luxury, spacious, sleeps 17, loaded and near new. GREAT CHARTER POTENTIAL!!!! Asking 975,000

58' ALDEN Boothbay Ketch. Center PH cockpit, aft S/R, dsl, heavy glass, world cruiser. AWESOME! Asking 268,950

38' INGRID Ketch by Atkins. Great extra STOUT BLUE WATER CRUISER. Glass double-ender, refit & upgraded, vane, diesel, furling, RADAR & MORE! Asking 51,950

38' CLASSIC English Ketch by Reg Freeman. Breathtaking beauty. **Reduced by 25,000!** Asking 99,950

33+ ROYAL HUISMAN ALUMINUM Cutter by Alan Gurney; World class builder and designer. Yanmar diesel, new standing rig, nav station, liferaft & MORE! Family emergency forces 50% PRICE SLASH. Must sell NOW! This is way too cheap for this vessel! Asking 19,250

32' GULF P/H by Wm. Garden. Diesel, F/G and MORE. Asking 13,950

32' ARIES Sloop. Double-ender by Tom Gilmer, F/G, dsl, bluewater cruiser... Asking 22,950

30' STEEL Slocum's Spray replica by Roberts. Dsl, new, unfinished project.. 14,900/Offers

30' TRIMARAN by Aynnaught. Folding, trailerable pocket cruiser. REDUCED. Asking 29,500

24' MELGES class racer with trailer and outboard. Fast and fair..... Asking 17,950

**POWER**  
130' CAMCRAFT Passenger Ship. Certified for 33 passengers overnight. Booked for the season. Virtual turnkey. Money and opportunity, working PNW..... 2,200,000

100' Steel HIGH ENDURANCE ADVENTURE/CHARTER SHIP in Panama. Turnkey operation. A great opportunity! MOTIVATED! Asking 1,500,000

85' CLASSIC TUG, '23 Vancouver Shipyard. Recent CAT V-12 repower. Massive, beautiful and seaworthy. Perfect for Classic Tug Yacht..... 179,950/offers

50' TRUMPY TRAWLER, Long range, great layout, 671 N-Series diesel. Needs TLC. A great boat!..... 44,950/offers

48' DUTCH CANAL Barge. Beautiful & comfortable Sausalito liveboard. Steel, diesel. MUST BE SEEN!..... Asking 219,000

45' STEPHENS 1929 classic. Beautiful Gatsby-era motoryacht waiting to transport you back to the days of yachting in the grand style..... Try 75,000

**43' CLASSIC EXPRESS CRUISER By CALLIS. Total & magnificent professional restoration.** Beautiful, stunning, ALL VARNISHED TEAK 1923 head-turner, copper riveted, tasteful & completely modernized & updated systems. MANDARIN has a fascinating history & is an important part of the West Coast Yachting tradition. Now **VASTLY REDUCED** to a fraction of her restoration cost! **MUST SELL NOW!** Asking 98,950

43' MATTHEWS, '65, diesel. A gem! Loaded and beautiful..... Asking 69,450

42' GRAND BANKS Tvl. Aft cabin, F/B, Onan, twin dsls, radar. Excellent..... 121,000

36' SEA RAY 360 aft cabin fly bridge express. Twins. Nice & a GREAT VALUE. Asking 34,950

34' CLASSIC LAKE UNION DREAMBOAT. We have TWO; a Blanchard and a Rathfon. Starting at a BARGAIN..... 17,500 Asking

28' BAYLINER 2850 FLYBRIDGE SEDAN. New VOLVO/GM 300hp V8, economical & 30+MPH reported. Just completely refurbished & refitted to exceptional condition..... Asking 19,950

27' FARALLON Pilothouse, '86. F/G, twin 5L V8s, fast and seaworthy. Just detailed and very nice..... Asking 51,950

22' ALUMINUM PLEASURE TUG. Bufflehead live/cruise. Loaded..... Asking 108,250



**43' POLARIS** Canoe-Stern Cutter. Proven cruiser. Dsl, furling, wheel steering, full galley, 14'6" beam, enclosed marine head w/shower, ship's table/settee, windlass and a great deal more! Wonderful Robt. Perry design and a great opportunity. Asking **\$129,950**



**43' D.M. CALLIS CLASSIC** 1923 Custom Express Cruiser, Mandarin. TEAK masterpiece. Famous from Roaring '20s on: Catalina, Hollywood, etc. Now exquisitely & totally refit with modern everything discreetly incorporated & true to designer's original intent. Exceedingly rare opportunity; AND she is fast! **Ask \$98,950**



**43' NEW ZEALAND-BUILT CENTER COCKPIT ENDEAU YAWL** Diesel, wheel, binnacle, dodger, cabin heater, great layout and more! Vessel requires significant work but will be an outstanding cruising boat when completed. MUST SEE! SHE'S A BARGAIN! Asking **\$24,950**/Offers



**57' BOWMAN** Ketch. An AWESOME vessel completely equipped for world cruising. TOO MUCH TO LIST; must be seen. Has circumnavigated and also completed the Northwest Passage east to west. Seaworthy, comfortable and roomy, this is your ultimate bluewater cruising yacht. Asking **\$219,950**



**44' STEEL** Canoe-stern cutter by Geo. Buhler/Fred Lagier & Sons. John Deere diesel. Stout steel construction. Awesome bluewater cruiser built to go to sea and stay there. Radar, GPS, etc. Here's your world beater! Asking **\$89,995**



**49' CUSTOM** Cold-Molded Ketch by Reliant. Beautiful Hankerson design. Powerful and seaworthy bluewater cruiser in great shape. Built '91. Yanmar diesel, furling, self-tailers, aux. genset, full galley, full electronics and MORE! MUST BE SEEN. Asking **\$119,950**

**CALL (510) 232-7200 OR FREE (877) 444-5087**  
**OR CALL GLENN DIRECT AT (415) 637-1181**  
**FOR INFORMATION & INSPECTION APPOINTMENTS**



**Your Complete Maritime  
Service Centers**

## **PT RICHMOND**

*services including:*

**ENGINE SERVICE  
ELECTRICAL  
RIGGING  
& MORE**

## **SAUSALITO**

*now scheduling for:*

**BOTTOM WORK  
FIBERGLASS  
PAINTING  
WELDING**

**3** Seminars scheduled!  
Rigging, Electrical &  
Diesel Engine Maintenance  
this October in the KKMI  
Boathouse in Pt. Richmond  
Call (510) 235-5564 or visit  
[kkmi.com](http://kkmi.com) as seminars will fill up!

*"Thanks to the whole KKMI team for the fantastic job they did on our Mason 44, 'Arione'. From our first contact, when Art called at 7am from somewhere off the Oregon coast, we felt confident that KKMI was going to get everything working, and you did. We're now on our way to the Baja Ha-Ha with renewed confidence in our new systems. Thanks so much!"*  
Jaye Eldridge & Art Stiers

KKMI Richmond, 530 W. Cutting Blvd., Pt. Richmond, CA 94804 (510) 235-KKMI (5564)  
KKMI Sausalito, 420 Harbor Drive, Sausalito, CA 94965 (415) 332-KKMI (5564)  
[www.KKMI.com](http://www.KKMI.com) for yard info, rates & more about KKMI Pt. Richmond & KKMI Sausalito