

Latitude 38

OCTOBER 2010

VOLUME 400

Latitude 38

VOLUME 400 October 2010

WE GO WHERE THE WIND BLOWS

OUR
400TH
ISSUE!

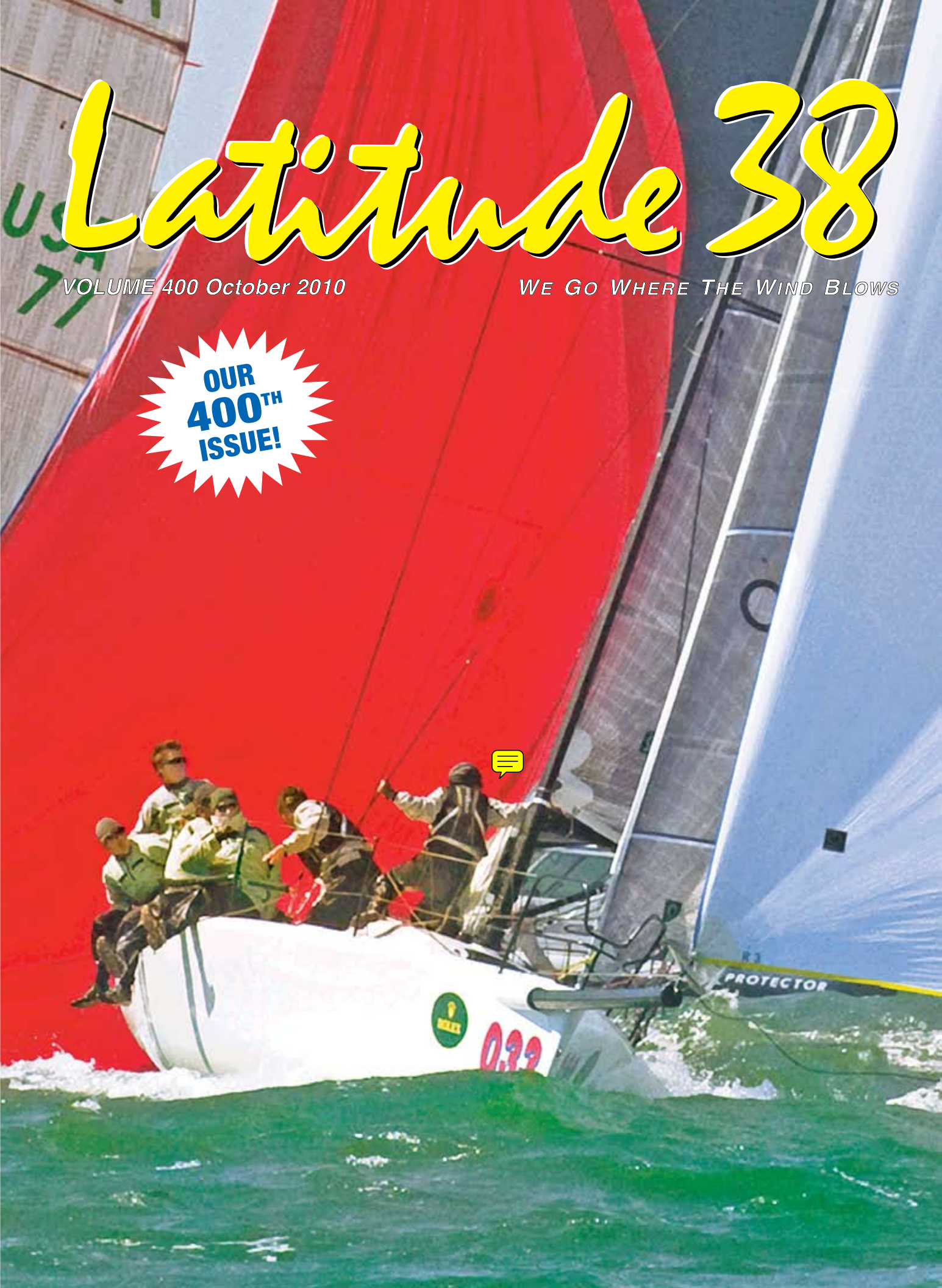

ROLEX BIG BOAT SERIES

At first blush, the 46th Rolex Big Boat Series appeared rather unremarkable. Absent were the four straight days of breeze into the 30s and sunny skies. Although the 98 boats in four IRC and five one design divisions eclipsed last year's 95 in four and seven respectively, the median waterline got smaller. But look a little closer, and you see that despite these differences, this year's event had some really remarkable aspects that made it every bit the regatta as last year's, if not more.

First of all, the weather, perhaps the most maligned — for good reason — part of this year's event had a silver lining. Despite the fact that the sun didn't show up really until Saturday afternoon, making for an admittedly unphotogenic regatta, the fog, cutoff low, and cooler inland temperatures that provided upper-level cloud cover and made for a gray Bay almost all weekend long, also provided some of the most visitor-friendly conditions in a while. With rare, and highly-variable wind angles, the breeze consistently trumped current as the major strategic factor. And local knowledge? You could throw at least some of it out the window.

Thursday's two races were sailed in pea-soup fog and breeze that peaked at around the mid-20s, which made for some challenging navigating and close calls with other boats and commercial traffic that provided the perfect test.

"Quite honestly we were lucky that a crewmember brought a handheld GPS aboard so that we were able to find marks," said 1D35 division winner Jon Hunt. "We were blundering around, overstanding marks and looking for marks where they were supposed to be, not exactly there. There were fog horns everywhere, it was disorienting, challenging steering with no visual reference, and the ferries and commercial traffic kept appearing out of nowhere. There was big stress in finding laylines, keeping track of competitors, and staying away from big steel bows, but big relief when the finish line came out of the fog."

As the breeze got lighter through the weekend, never getting much higher than the mid-teens, another benefit was that it made for a less physically taxing event.

"You didn't get off the water feeling like you'd been in a heavyweight wrestling match," observed J/120 division winner Don Payan. "Usually, you get off the water and you're black and blue and sore. This was very civilized."

Unfortunately, the weather did make for an abbreviated Bay Tour on Sunday and no race to Pt. Bonita for the second year in a row.

Where last year's headline-grabbing class was IRC A, this year it was the Melges 32s, the only grand prix one design class in America at the moment, sailing their pre-worlds at the event. Along with the IRC A divisions, the 32s provided the bulk of the top-level pros found on the docks, both sailors and coaches, as well as the international flair — the regatta boasted entries from New Zealand, Canada, Mexico, the Czech Republic, Japan and Great Britain. This year marked the first time since probably the Farr 40 days of yore that there was a big concentration of talent present at the Rolex Big Boat Series.

Melges 32

The Melges 32s represented the smallest boats at this year's Rolex Big Boat Series, but drew the largest fleet, and so sailed



LATTITUDE/ROB

Stefano Nicolussi, Luca Faravelli, Federico Michetti and skipper Luca Lalli are all smiles after winning the Melges 32 division at the Rolex Big Boat Series; spread, a handful of the 27 boats roll toward Alcatraz on Friday afternoon; inset, hike!!

DANIEL FORSTER/ROLEX



— GRAND PRIX ALL THE WAY



ERIK SIMONSON/WWW.H2OSHOTS.COM



ROLEX BIG BOAT SERIES

DANIEL FORSTER/ROLEX



Mick Shlens and Mark Jones' TP 52 'Flash' pokes a hole through Thursday's gloom.

for a Rolex and the Commodore's Cup. So how grand prix was this fledgling class for whom the regatta was a warm-up to its second-ever World Championship the following week? Enough that St. Francis YC PRO John Craig had to make an announcement at the skippers' meeting that RIBs would be strictly prohibited from tying up to the guest docks, and that any additional trailers that made their way to the parking lot east of the club and were hooked into the power grid — which incidentally covered every available outlet on that end of the building — would have to keep their cords tidy, because well, there were just too many of each!

Twenty-seven-year-old former 470 sailor, Italian Luca Lalli's *B-lin* — named for a colloquial expression that adorned his first 470 — won the tight division with no local knowledge other than an animated web-based current map aboard. Carrying a one point lead into the final race, Lalli dispatched his closest competition with a bullet in the final race.

"Basically we just tried to control our competition on the starting line," Lalli said. "When [Jeff Ecklund's] *Star* went for the harbor, we knew we had won the regatta."

While doing that without any local knowledge aboard is remarkable in and of itself, it's all the more so when you consider that *B-lin* sails with only basic electronics.

"We don't sail with GPS," Lalli said. "That made it difficult in the fog situation, but we had focused one learning where the stationary buoys were."

Lalli and his crew of Italian aces like

Lorenzo Brassani, Flavio Favini and Melges Europe's Federico Michetti along with Stefano Nicolusi, Luca Faravela, Carlo Zermini and Lorenzo Del Rio reigned supreme in a class replete with America's Cup, Volvo Ocean Race and Olympic talent. Talent like

Stu Bannatyne, the Wilmot brothers, the Greenhalgh brothers, Jonathon McKee, Morgan Larson, Tony Rey, John Lovell, Scott Nixon, Chris Larson, Gavin Brady, and on, and on, and on, and on. The coaching ranks were just as star-studded with people like Dee Smith, Trevor Baylis and Dave Ullman following their charges around in RIBs all weekend long.

There were so many good sailors in

Spread, 'Vincitore' and 'Wasabi' cross tacks; inset left, Dale Williams with the spoils of victory; inset middle, Colin Booth and Jim Mitchell join Ricardo Brockmann and 'Peligrsoso' owner Lorenzo Berho for the official hand-over; inset right, Jorge Ripstein's 'Patches' made 'Vincitore' work for it.

the class that some of them had to finish deep, and you'd be surprised to see where many of them ended up. The top local boat was John Kilroy Jr.'s *Samba Pa Ti* in seventh place, while Don Jesberg's *Viva* ended up in 11th, Philippe Kahn's *Pegasus MotionX* in 14th, and Stephen Pugh's *Taboo* finished in 16th.

But all those big names didn't seem to bother Lalli, who works for his family's construction business.

"We know we aren't slow, and we're happy about that," Lalli said. "Next week, we go to the World Championship, and we know we can win."

Turns out, he was right, and you can see the pictures in this month's Racing Sheet.

IRC A

While not large at only five boats, IRC



LATTITUDE/ROB



LATTITUDE/ROB



DANIEL FORSTER/ROLEX

— GRAND PRIX ALL THE WAY

A was a high-quality fleet that featured some truly grand prix programs that hailed from the U.S., Canada, Mexico, and nominally New Zealand. The biggest boat in the regatta, Lorenzo Berho's Kernan 68 *Peligroso*, was never able to shake the 52s that made up the rest of the division. Defending champion Jim Mitchell and his electric blue R/P 52 *Vincitore* were back to defend their title against last year's runner up, Mark Jones and Mick Shlens' TP 52 *Flash*, Ashley Wolfe's TP 52 *Mayhem*, and Rolex Big Boat Series newcomer Jorge Ripstein and his TP 52 *Patches*.

Mitchell, a Chicagoan now based out of Geneva who races only in North America and sails under the burgee

of the Royal New Zealand Yacht Squadron, left no stone unturned in defense of his trophy. Mitchell recruited an all-star crew that included talent like helmsman Chris Dickson, project manager Rodney Keenan, boat captain Colin Booth, Rodney Daniel, Scott Beavis, Bob Wylie, Jamie Gale, Hayden Goodrick,

Martin Hannon, Simon Minoprio, and Jack To-liver. They were joined by Andres Soriano and Ricardo Brockmann.

That turned out to be a good call, as just like last year, the division win — with it a Rolex and the St. Francis Perpetual — came down to the last race of the regatta. Going into Sunday's race, *Vincitore* and the Reichel/Pugh-designed *Patches* were tied on points at 12 apiece after a wild series. With former match racing world champion and Louis Vuitton Cup skipper Peter Holmberg calling the shots and some of Southern California's best, like Bruce Cooper, Steve Dodd, Keith Kilpatrick, and Erik Shap-

main, backing him up, Ripstein steered his new-to-him and newly-IRC'd boat to four straight bullets after a DSQ in Race 2, setting the stage for a dogfight that saw the two boats launch into a tacking duel shortly after the start on the Cityfront course: *Vincitore* gained the advantage off the starting line and only looked back to make sure they were between their competition and the next shift, finishing the race 30 seconds ahead of *Patches* on corrected time.

"Usually you plan it all out and it doesn't happen like you want it to," Dickson said. "This was one of those times that it worked out. Having said that . . . they still had a good shot at it. At the last mark with all that work done, we still needed to make up 10-15 seconds on our time to beat them."

Just like last year, Mitchell was quick to point out that as sweet as the win was, it was all the better that his dad, who got him into sailing, was there to see it again, watching the racing from a chase boat.

"I've had three great years of memories here with my dad," he said.

Still, Mitchell said the win was bittersweet, as it was his last regatta with the three-year-old boat. Acapulco-based Brockmann — a longtime campaigner, Most recently in his Concordia 47 *Ruahatu* — made Mitchell an offer that was too good to refuse, with the hand-over planned for the conclusion of racing. Mitchell said he'd been playing around with the idea of going slightly bigger when he got a call out of the blue.

"Ricardo contacted me and said, 'I really love your boat, and I want to buy it,' and that made up my mind," Mitchell said.

Mitchell explained that in anticipation of a crop of TP 52s coming to North America, he and his team analyzed what would make the most sense, and 55-foot seemed to be about the right size for buoy racing, his beloved Mackinac races, and

Robbie Haines and Dan Woolery make a winning combo on 'Soozal'. The duo have won the West Coast IRC Championship two years running.



LATITUDE/ROB

maybe a TransPac in the future.

"It should give us a little more speed off the starting line to get clear of everyone else, and be just that much faster offshore," he said.

Construction on the new boat is already underway at Davie Norris Boat-builders in Christchurch, New Zealand — which came through the recent 7.1 earthquake unscathed — and with a projected launch date of June. Mitchell said that though it will be tight, there's a good chance he'll be at next year's Rolex Big Boat Series with his new steed.

Patches — which seemed to excel in the lighter air on Friday, Saturday and Sunday — proved to be very competitive, remarkable given the timeframe Ripstein had to prepare her. The boat's first race was the Santa Barbara to King Harbor Race in early August. Immediately after she was hauled, her keel bulb was sent to Mexico to have another 800 pounds added to it while she was being reconfigured for IRC with split topmast backstays and a squaretop main that was purchased on E Bay from the Russian Audi Med Cup team. Finished just in time to make the trip north, the boat proved to be just the right weapon for Ripstein, a seasoned campaigner who has owned some of the West Coast's most storied race boats such as *Nitissima*, *Persephone* and most recently, the ILC 46 *Wasabi*.



DANIEL FORSTER/ROLEX

ERIK SIMONSON/WWW.H2OSHOTS.COM



ROLEX BIG BOAT SERIES

IRC B

Sailing for the City of San Francisco Perpetual Trophy, IRC B turned out to be a competitive division despite great disparity in the age range of the seven boats that contested it. Dan Woolery and his Pt. Richmond-based King 40 *Soozal* dominated their division as they've done in just about everything they've entered since the boat was launched in January of last year. Woolery and tactician Robbie Haines were so good, in fact, that they wrapped up the regatta with a day to spare, although it didn't stop them from going out for fun on Sunday.

"If you come out to race, you don't backpedal," Woolery said. "So we decided to go out and stay out of everyone's way, since there was a three-way tie behind us. But, we ended up right in the middle of everyone anyway."

Woolery had many of his regulars aboard, including Gary Sadamori, Greg Felton, Chris Lewis, Dave Gruver, Matt Siddens, Andy McCormick and Pete McCormick. Conspicuously absent was project manager Scott Easom, who had already committed to one of his other projects, Lani Spund's *Kokopelli*².

As it turned out, *Koko* finished the regatta in second, breaking a three-way tie despite not being an IRC design and having been designed about 17 years prior to *Soozal*. Amazingly enough, the boat *Koko* beat was the '85 Reichel/Pugh 47 *Flyer*, successfully campaigned on the Bay by Bill Twist in the IOR heyday under the *Bladerunner* livery. The classic speedster, unlike a lot of boats from her era, is in great shape beat a purpose-built IRC racer, an IRC-optimized Farr 40, an IRC-optimized IMS boat and an IMS boat to finish on the podium — pretty impressive

'Masquerading' as 'Arbitrage' — due to a recalcitrant rudder bearing, Bruce Stone drove a borrowed boat to victory in the J/105 class.

for a true warhorse from a bygone era.

After his two years of beating the pants off all comers, we asked Woolery what he had planned next now that he's carted off the West Coast IRC Championship for the second year running.

"We got a slip down in Dana Point, so the boat is going to get a coat of bottom paint, the roller furling gear will go on and we're going to do some cruising in Southern California over the winter," Woolery said. "After that we may head to the Florida regattas next winter after Big Boat Series, depending on the economy. It doesn't make much sense to take the boat over there if there aren't going to be many boats."

Although he wouldn't commit to it, he said there's chance he may go bigger.

"I've been thinking about a 52," he said, "I haven't made up my mind yet. But I would really like to keep this great crew together."

IRC C

The Richard Rheem Perpetual went to IRC C this year, and in somewhat of a departure, the division was organized not around a particular rating band, but rather a typeform: ultralight sportboats under 50 ft that typically struggle under IRC. After sailing as a David among Goliaths last year and still coming in second, Dale Williams' Kernan 44 *Wasabi* was the Goliath in her division this year, racing against a pair of J/125s, a pair of Farr 36s and a Santa Cruz 37. *Wasabi* lived up to her billing as the scratch boat, scoring straight bullets to close out the series with an extraneous one.

"It was never in the bag," Williams said. "When you're racing on San Francisco Bay, you are never secure."

As it turns out, *Wasabi* only walked away with one race, and finished a little over a minute ahead of the next boat in another. The rest were all within about 45 seconds, due in no small part to a crew that included Craig Fletcher, Richie Eggerman, Steve Baumhoff, Garrett Greenhalgh, Drew Harper, Kernan, David Oborn, Malcolm Park, Pete Heck, Greg Williams and tactician Kevin Miller.

At the trophy presentation, Williams made special mention of his



The J/105s soak downwind in the mellow (but finally sunny) conditions on Sunday.

late friend and boat partner Mike Campbell — with whom *Wasabi* was started a couple years ago — dedicating the win to him and saying that it was the realization of "a dream" they had shared.

While it may not have been Williams' last regatta with the boat, he's already got a new one in the works — a 54-footer from Kernan.

IRC D

Tom Brott probably never thought he'd go home with a Rolex after his first Big Boat Series, but the Long Beach-based J/109 sailor did just that by winning the seven-boat IRC D division. In the process, Brott not only got his name on the Keefe-Kilborn Perpetual, but dethroned the division's defending champ in the process.

"The lighter air really helped us," he said, explaining that *Electra* was rated with her overlapping headsails, whereas most Bay Area boats get rated without them because they get used so little in Central Bay racing.

But the winning effort nearly didn't get underway for Brott and his crew of tactician Harry Pattison, Leslie Baehr, Tom Parry, Will Vrooman, Jay Doerrer, Paul Corrigan and Mike Crawford, when a jib halyard snafu during race one left



DANIEL FORSTER/ROLEX

— GRAND PRIX ALL THE WAY



nial perch as the largest one design class this year, but not by much. Twenty-four of the Bay's top boats showed up to compete for the Atlantic Perpetual trophy and a Rolex, and as can be expected, there were no freebies. The top bullet-getter was Scooter Simmons' *Blackhawk*, but the adage that consistency wins regattas proved true for Bruce Stone's *Arbitrage*. Stone, last year's runner-up, scored only one bullet the entire regatta — in the first race — but counted nothing lower than a seventh to finish six points clear of *Blackhawk*.

That kind of consistency would be remarkable in and of itself, but given the fact that Stone and his tactician Brent Draney and crew Stu Johnstone, Julia Lankford, Bob Dearborn and Mike Strauss had to do it on two different boats makes it all the more remarkable. After winning the Bay's J/105 season with sticky rudder bearings, Stone decided to

replace them before the Rolex Big Boat Series. On day one, the replacements had become so stiff that Stone was able to steer downwind with only his hip. *Arbitrage* was up to the task and Stone managed to score a 1-4, but by the end of the day felt he had to make a change.

"I called (previous national champion) Tom Coates, and the first thing he said was, 'don't tell me you broke your boat!'" Stone said.

Coates offered up his *Masquerade* to the *Arbitrage* crew. Stone said they had a diver check the bottom and the report was encouraging, so they set about tuning the rig and crossed their fingers. "We went out and got a 2-3 on Friday, so we felt pretty good about our chances after that," he said.

Stone, who races J/105s on both coasts, incidentally won not only the Bay's Fleet 1 championship this year, but also Newport, Rhode Island's Fleet 14 series, thus consolidating the titles for at least a year.

Perennial contender and defending champion Chris Perkins hadn't sailed his *Good Timin'* all year long as he'd been working for BMW Oracle Racing as their CFO and spending any free sailing time qualifying for the IKC back in August. After a Z-flag penalty in the first race, Perkins managed to claw his way back into fourth, just behind Jeff Litfin and John Case's *Mojo*, while Rolf Kaiser's *Donkey Jack* rounded out the top-five.

J/120

The J/120s can always be counted on

them with a DNF to start the event.

"With a DNF in that first race, we were coming from behind the whole regatta," Brott said "But, it was having a great crew, and Harry, and being able to concentrate on driving that did it."

Going into the last race, Brott and his team needed only to put a boat between them and defending champion Gerry Sheridan's *Tupelo Honey*. They ended up getting two boats between them to eke out the win in the incredibly tough division where the top-three finishers were separated by only one point.

J/105

Due to the abundance of Melges 32s, the J/105s were knocked off their peren-

Chris Boome, left, and Kame Richards sailed 'Golden Moon' to a convincing win in the Express 37 class; the Expresses box-in the R/C boat.



LATTITUDE/LADONNA



KATY WEBER

ROLEX BIG BOAT SERIES

to provide one of the closest divisions in the Rolex Big Boat Series, and this year was no exception. It did however break from tradition in a couple ways. First, unlike the last three years running, where the regatta has come down to the final leg of the final race, this year's winner was neither Steve Madeira's *Mr. Magoo* or Barry Lewis' *Chance*. In the second major change for the class, it was Don Payan's *Dayenu* that walked off with the title.

"I've lost on a tiebreaker and been second or third before, but this was the first time I've won as owner," Payan said. "It was a fun regatta and it was such a thrill to win it finally after all these years of being the bridesmaid."

Payan and tactician Peter Cameron's victory was pretty emphatic: three bullets and nothing lower than a fifth over seven races in the eight-boat division.



Tom Brott sailed his J/109 'Electra' to a win in IRC D in his first Rolex Big Boat Series.

"The trick in the Big Boat Series is consistency," he said. "This fleet is so competitive, you cannot expect to win it if you have a bad race. For the first time

we were very consistent."

But while *Dayenu's* scores may have been consistent on paper, they required a lot of fighting to get that way. Payan cited Saturday morning's race as an example.

"We had to do a penalty turn shortly after the start and were in seventh around the last weather mark," he said. "Peter made an amazing call to stay right and deep. Uncharacteristically, I kept my mouth shut, and we went from seventh to second. When we did that I said to myself, 'we can win this thing.'"

Cameron, local rigger and electronics specialist who counts in his resume serving as boat captain aboard the late Irv Loube's *Bravuras* and Bob Garvie's *Bullseye* was a late pickup on an established crew that included Steve Bates, Tom Warren, John Verdoia, Michael Cal-

2010 ROLEX BIG BOAT SERIES RESULTS

YACHT	OWNER	YACHT CLUB	1	2	3	4	5	6	7	TOTAL
IRC A										
1. Vincitore	Jim Mitchell	Royal New Zealand YS	1	1	3	2	2	3	4	16
2. Patches	Jorge Ripstein	Acapulco	2	6/DSQ	1	1	1	1	5	17
3. Flash	Mick Shlens/Mark Jones	King Harbor YC	3	2	2	4/SCP	5	2	1	19
IRC B										
1. Soozal	Dan Woolery	Richmond YC	4	1	2	3/SCP	1	2	1	14
2. Kokopelli²	Lani Spund	Royal Ocean Racing Club	5	2	5	5	3	1	2	23
3. Flyer	Rob Sjostedt	Corsair YC	2	4	1	3	7/SCP	4	3	24
IRC C										
1. Wasabi	Dale Williams	St. Francis YC	1	1	1	1	1	1	1	7
2. August Ice	Richard Ferris	Tahoe YC	3.5	3	3	2	2	3	2	18.5
3. Double Trouble	Andy Costello	Corinthian YC	2	2	2	3	3	2	7/RAF	21
IRC D										
1. Electra	Tom Brott	Seal Beach YC	4	8/DNF	1	1	2	1	2	19
2. Tupelo Honey	Gerry Sheridan	South Beach YC	1	4	3	4	1	2	5	20
3. Hawkeye	Frank Morrow	USNA Squadron	3	1	2	6	3	3	3	20
MELGES 32										
1. B-lin Sailing	Luca Lalli	CN Marina di Carrara	5	3	4	3	18	1	1	35
2. Bliksem	Pieter Taselaar	New York YC	2	1	8	2	19	7	8/ZFP	47
3. Red	Joe Woods	Royal Torbay YC	1	12	6	5	14	5	8	51
J/105										
1. Arbitrage	Bruce Stone	St. Francis YC	1	4	2	3	5	7	5	27
2. Blackhawk	Scooter Simmons	San Francisco YC	5	1	4	11	1	10	1	33
3. Mojo	Jef Litfin/John Case	NA	4	2	7	4	12	5	7	41
J/120										
1. Dayenu	Don Payan	St. Francis YC	3	1	5	1	2	1	2	15
2. Mr. Magoo	Steve Madeira	St. Francis YC	7	2	1	3	1	4	3	21
3. Desdemona	Barry Lewis	San Francisco YC	1	5	2	4	3	2	7	24
EXPRESS 37										
1. Golden Moon	Kame Richards/Bill Bridge	Encinal YC	2	1	1	2	3	1	1	11
2. Eclipse	Mark Dowdy	San Francisco YC	1	4	3	3	1	3	4	19
3. Elan	Bill Riess	Richmond YC	4	2	6	1	2	2	7	24
1D35										
1. Dark and Stormy	Jon Hunt	SSS	1	2	1	1	1	1	1	8
2. Ebb Tide	Masakazu Toyama	Seabornia YC	2	1	5	4	2	5	4	23
3. Zsa Zsa	Stan Glaros	Corinthian YC	5	3	3	5	3	2	3	24

— GRAND PRIX ALL THE WAY



COURTESY DAYENU

The 'Dayenu' crew — front row from left, Tom Warren, Kurt Hemmingsen; second row, from left, Peter Cameron, Debra Hong, Don Payan, EJ Rowland, Steve Bates, Jeff MacDougall, Mike O'Callaghan, John Verdoia, and Randy Smith; right — 'Dayenu' soaking downwind.

lahan, Kurt Hemmingsen, Debra Hong, Jeff MacDougall and EJ Rowland.

"Our regular tactician moved back east, during the final stretch of the season," Payan said. "We said, 'what are we going to do?' I called Peter, who came on for Aldo. The crew was skeptical of breaking in a tactician that late in the season, but he's been great. He's very good at the coaching element of tactics and he has really high standards."

Even so, like any tactician, Cameron wasn't right all the time. At the start of the final race, he thought that *Dayenu* was over early and wanted to restart, but Warren, who was up on the bow, disagreed.

"Peter said, 'we're over,' and Tommy yelled back and said, 'we're not,' and Peter said 'we're over,' and Tommy yelled back again and said 'we're not.' All the boats around us were laughing."

Knowing they had to get only a fifth or better to win the regatta, they sailed conservatively for the rest of the race, and still ended up finishing second.

Express 37

While the headline-grabbing might have come from the newest one design class at the Rolex Big Boat Series, you just can't beat consistency, and '10 marked the 20th year the Express 37s have participated as a class in the Rolex Big Boat Series. After two straight years of this class's winner getting a watch, it was the Melges 32s' turn this year. So it shouldn't have been too much of a disappointment for Kame Richards' *Golden Moon*, which repeated as the division's winner, picking up his fourth title in eight years.

"We look mean and obnoxious on paper, and in reality we're quite polite,"



DANIEL FORSTER/ROLEX

Richards said.

On paper Richards and his crew, which included boat partner Bill Bridge, Aimee Daniel, Andrew Hura, Brad Jeffrey, Eliza Paulling, Jeannette Daroosh, Mike Mannix, Todd Hedin, Tom Paulling, and guest tactician Chris Boome, won their division convincingly with a 2-1-1-2-3-1-1 to finish eight points clear of Mark Dowdy's *Eclipse*. Richards was quick to attribute that to his crew.

"I was looking at all the YRA and Wednesday night races we did and a huge percentage of our crew sailed everything. Everyone had done everything together over and over so the mechanics of sailing the boat were delightful. We had exactly one guest, and that was Chris, and he's really good."

Another helpful guest was a brand new touchscreen chartplotter.

"On the first two days it was wonderful," Richards said. "We never would have done that well without that piece of equipment, and the best thing is that you can figure out how to make it work without getting the manual out."

Golden Moon carried three new sails, which Richards, whom you probably know owns Pineapple Sails in Alameda, said didn't hurt.

"We replaced the main, which I didn't

feel bad about because it would have been its seventh Big Boat Series," he said.

Although the class's numbers were down by one, Richards said that it worked out in his favor. Perennial campaigner Mick Shlens, who typically races his well-sailed *Blade Runner* and came on strong last year to finish just two points shy of *Golden Moon*, has been chartering Mark Jones' TP 52 *Flash* throughout the year, and sailed the latter boat this year in IRC A.

"I thanked him profusely for sailing in the 52 class," Richards said.

1D35s

The 1D35 division slipped in attendance this year, with two-time winner Gary Boell having moved on to a Flying Dutchman. In his place, class newcomer Jon Hunt wasted no time in assuming the role of division winner, posting five bullets and a second in the seven-race series to wrap up the title with Sunday's race to spare. Although they didn't need to leave the dock on Sunday, Hunt's crew aboard *Dark And Stormy* sailed the last race for good measure and won it too!

"We had a memorable and remarkable Big Boat Series," Hunt said. "Our crew worked flawlessly and we had a bit of extra speed every now and then thanks to

ROLEX BIG BOAT SERIES

our trimmers, who were constantly working to find something extra. As helmsman I still have 'two degrees up!!,' 'one degree down!!,' 'right there!!,' and, 'shut up and concentrate!!' ringing in my ears."

Hunt didn't pull any punches in recruiting a high-level crew, getting Olympic coach Rodney Hagebols to call the shots for the team of Nedko Vassilev, Howard Bentley, Kim Stuart, Michaela Draper, Sherry Smith, Ron Wizelman and Tone Chin.

"We won our class by getting good starts, not engaging in useless boat for boat confrontations, working on boat speed on the first weather leg, rounding the weather mark leading or in the top 2-3, and then defending downwind," Hunt said.

He's only had *Dark And Stormy* for 1.5 years, and said he's been sailing slower boats, "but not at this level," for at least 15 years. His result suggests he's a quick study, and he seems pretty happy with the boat.

"The 1D is the best speed for the dollar available on the used boat market as far as I am concerned," he said. "There

is some good one design racing, good camaraderie and cooperation amongst the owners, a large loyal crew pool, and it has a carbon mast that can be turbo'ed. It's an older design that's still on the leading edge and available for less than \$100K."

Returning for a third year in a row was Masakazu Toyama's *Ebb Tide* team from Japan. A crowd favorite at the awards ceremony, the always-smiling Toyama and his team narrowly beat Stan Glaros' *Zsa Zsa* to defend their runner-up title from '09.

The Rolex Big Boat Series is the bellwether big boat regatta on the West Coast and the signals it put out were pretty positive. There are new boats on the way, and at least one of those will be replacing a competitive boat that will stay on the West Coast.

There are also a couple new projects in the 40-plus-ft range slated to come online pretty darn quickly, which is a great sign. The presence of Big Boat Series newcomers bodes well for the

future of the event also; hopefully the fact that some of them enjoyed success will encourage other to take the plunge and join the fun. Right now it seems as though half the SoCal 52 fleet is for sale, and if those boats ever get in the hands of people who want to sail their planing boats at planing speeds, then we could see a viable revival of the TP 52 in its most perfect venue.

But as much as the "new" is essential for the growth of the event, the continued presence of the Rolex Big Boat Series stalwarts provides the base on which the regatta can build. And the stalwarts not only showed up this year, but in many cases really ramped up their programs.

Certainly a big challenge for the organizers will be to offset the loss of the Melges 32s, which although likely to come back, probably will not do so in the numbers seen this year. But given the St. Francis YC's track record with finding solutions, the gray gloom may have occluded marks and ferries, but it hasn't occluded the Rolex Big Boat Series' bright future.

— latitude/rg

CUSTOM GEAR FOR YOUR REGATTA OR TEAM

BIG BOATS
LITTLE BOATS
BIG EVENTS
LITTLE EVENTS

We've got you covered!

PIRATES + LAIR
WWW.PIRATESLAIR.COM
CALL: 888.SAIL.BUM

Gill Hanes Pro-Fit GILDAN PORT AUTHORITY

T-SHIRTS & CAPS
POLOS & SHORTS
SCREEN PRINTING
MOISTURE WICKING
DYE-SUBLIMATION
TECHNICAL GEAR
EMBROIDERY
DESIGN

OFFICIAL GEAR SUPPLIER
MOUNT GAY RUM
BARBADOS
WWW.PIRATESLAIR.COM

CUSTOM REGATTA GRAPHICS HERE

©2010 Mount Gay Distilleries Ltd., Mount Gay® Barbados Rum, 40% Alc/Vol., Imported by Rémy Cointreau USA, Inc., New York, N.Y. Eclipse Design™ Be Confident. Drink Responsibly.

Electrifying Results!

1st and 2nd in the most competitive Rolex Big Boat Series IRC class



Results on the race course are testament to the quality of the boat, the crew and the pre-race preparation...

Results in IRC B:

<i>Soozal</i>	Dan Woolery	First Place
<i>Kokopelli²</i>	Lani Spund	Second Place

Both boats prepared by Easom Rigging with electric hydraulics and electric winch packages.

"Soozal is the best IRC boat on the planet."
- Norman Davant



Kokopelli²



Harken electric winch

Congratulations to Dan Woolery and his crew on *Soozal* and Lani Spund and the crew of *Kokopelli²*.

Let us show you how easy it can be to sail the Bay.

Easom Racing and Rigging

1150 Brickyard Cove Rd. Suite B1
Point Richmond, CA 94801

(510) 232-SAIL (7245)

www.easomrigging.com



PASSIN' THROUGH

Every fall, the Bay Area brims with visitors — tourists in the City, migrating birds in the trees, and cruisers on the Bay. The latter group is an eclectic bunch. Some have gleaming new, factory-finished yachts, others sail older but still serviceable production boats, and a handful are kickin' it old-skool with owner-built beauties.

In the following pages, you'll meet the crew of seven transient boats that passed through the Bay Area last month, and you'll find their cruising styles are as diverse as their boats. From the Norwegian couple who've sailed halfway around the world on a pocket cruiser to the French family who've made the same journey on a luxury catamaran. From the folks whose trip down the coast from Victoria was their first offshore passage to the Vancouver-based couple who sailed to Chile, spent a winter on the Beagle Channel, returned to Vancouver, and are once again on their way south. Though their stories are different, they're all fascinating.

Over the next couple months, if you find yourself anchoring next to someone with a distant hailing port or a foreign courtesy flag, take a moment to welcome them to San Francisco Bay. If you see a new boat in your marina's transient slip, offer them a ride to the grocery store or West Marine (something *always* breaks on the way down the coast). By all means, invite them over for a cup of tea or a cold brew. But remember that these folks are on 'cruising time' — which just means that you'll be highly entertained by real-life sea stories for as long as you have available. That's never a bad thing!

— *latitude*/ladonna



Karina C, Spencer 35, Nanaimo, B.C. — Some cruisers have saltwater running through their blood; Jay and Anita Bigland have music running through theirs. A retired music teacher, Jay started sailing on a Thunderbird in the early '80s. Over the years, the couple traded out boats, finally settling on *Karina C* in '01. "We lived in Prince George and would spend our summers on the boat," Jay explained, as he pulled out his Martin backpacker guitar. "Anita and I are lifers — married 34 years," he continued, plucking a few strings absentmindedly. "This is what she said to me on our first date" and he started playing 'Dream a Little Dream' as Anita sang along.

But it was, in fact, Jay's dream to go cruising. "He said to me, 'Wouldn't you like to get away from the cold and snow?'" recalled Anita. "I suggested getting a condo in Palm Springs, but he said that would be too expensive, and that it would be so much cheaper on our own boat. We've never spent so much money as we did refitting *Karina*!"

"When some people go into an old folks' home, they wonder 'what if,'" Jay said by way of explanation. "I'm not going to wonder. But we're more concerned with each other than with the boat, so if either one of us said we were done, we'd stop."

Karina C is entry #161 in the Baja Ha-Ha, which kicks off at the end of this month, and both say they're really looking forward to it. "We'll probably leave the boat in Mexico and commuter cruise for awhile," said Jay. When asked what got him interested in sailing in the first place, Jay said that they'd been on their powerboat many years ago when he looked out and saw a bunch of sailboats plying the waters of Howe Sound. "I turned on the radio and this was playing" We were once again serenaded, this time to Christopher Cross's classic 'Sailing'.



Comocean, Catalina 42, Blaine, WA — Gary and Sonia Hurt believe in living their life by design. "I got this book on tape called 'Life By Design' and it really changed my life," said Sonia. "The basic premise is to figure out what you want in life — in our case, it was to go cruising — and then every decision you make from that point on is made with your end goal in mind." The Hurts worked up a seven-year plan that included buying a boat, selling their house, and quitting their jobs — Gary's as a database administrator, Sonia's as a marketing director.

First came the boat, which they bought in Anacortes in '01. "We put it in charter while we still lived in Sonora," Gary explained. "With what we saved in taxes, it really worked for us." Next came paying off the boat, which meant selling their house. "I started selling all our stuff years before the house sold," laughed Sonia. "She became an eBay Power Seller," added Gary. Then, in '07, they retired — though Gary still consults for the same company — and moved to Washington to live aboard full-time. "It's funny," said Sonia. "We lived in Sonora for many years and had just a handful of friends. In just six months, we had more friends in Blaine than we ever had in California."

The Hurts chose an excellent weather window to make their way down from Neah Bay. "We came down nonstop; it was our first overnight passage," said Gary. "We had a wonderful beam reach till we reached Reedsport, and the wind just died." Consequently, they're among of the handful of cruisers who didn't have any breakages on the trip south.

As for their future plans, they say they'd originally planned to cruise six-and-six. Not the typical six months in Mexico, six months at home — remember, they'd sold the house. No, they were going to spend waii for summers. "But after the five days of no sleep coming down here," said Sonia, "this might be a once in a lifetime trip." But don't give up on them yet. As Gary noted, "you may get used to it."

Bika, Contessa 26, Stavanger, Norway — Two weeks after being turned down for a home loan in '03, Henrik Nor-Hansen and Nina Nilsen bought their 26-ft *Bika* thinking she'd be a starter boat. "But then we began reading about pocket cruising," Henrik recalled, "so we decided to stay with *Bika*." Originally planning a three-year cruise, the couple set out from Norway in '05 and haven't looked back.

That's not to say they haven't strayed from *Bika* on occasion. "We haven't been on the boat the entire time," said Nina. "We go back to Norway for a few months at a time so I can work [as an environmental engineer]. One winter, we spent eight months caretaking an isolated cabin in northern Canada, and we hope to spend this winter housesitting in Anchorage." (As a novelist and poet, Henrik can work anywhere.)

In fact, it's been more than a year since their last big ocean crossing, which was a particularly rough trip from the Bahamas to Cape Hatteras. "We saw five waterspouts in one day," recalled Henrik. "It was raining so hard that the seas were flattened."

Surviving the deluge, the couple spent some time exploring America aboard *Bika*, from the Great Lakes to Texas. There they completed a major refit. But instead of taking the time and expense to sail the little red boat through the Panama Canal, they put her on a truck bound for the Bay. "It was much cheaper," said Henrik, "plus I wanted to see San Francisco."

Bika and her crew arrived in May, spent some time in the driveway of a friend's Central Valley home working on a few leftover projects, and have been bouncing around the Bay for the rest of the summer. They left last month, bound for Mexico and, ultimately, Norway.

When asked about her favorite place visited during their trip so far, Nina hedged. "I don't like saying I have a favorite because that takes away from all the other wonderful places we've been. But I will say that Morocco was the biggest surprise — the people were super friendly — and we've really fallen in love with the Bay. Sailing here is serious business. For us, San Francisco is a very inspiring city and we can't wait to come back."



PASSIN' THROUGH

ALL PHOTOS LATITUDE / LADONNA

Riki Tiki Tavi, Coast 36, Victoria, B.C. — A homebuilt boat is always impressive — all those long hours! — even if it isn't very pretty. But when it's as beautiful and well-built as Ray and Marnie Summers' *Riki Tiki Tavi*, you just have to sit in awe. "I built her from scratch — laid up her hull in a one-off mold — over the course of seven years," said Ray, a retired industrial tool designer, adding that he stretched the original design by two feet. Asked if he felt building the boat himself was worth it, Ray said "We saved about 50% but I'd never do it again — next time I'd just buy a production boat!"

Having spent the last four years cruising the Gulf Islands and dreaming about warmer lands, Ray and Marnie decided to fully commit to the cruising lifestyle by selling their home. "We didn't want to wait around on the porch waiting for the kids to come around," laughed Marnie.

They set off on their first offshore passage early last month, intending on a non-stop trip to San Diego before spending the winter in Mexico then heading off to the Marquesas and, ultimately, New Zealand. "We didn't mean to pull in to San Francisco Bay," said Ray, "but we were battered by a storm a week ago and some things broke."

They planned on spending a couple weeks in the Bay, working on the boat and recuperating from their beating. "It was so bad at one point that Ray told me to draw the drapes and to not look out," Marnie recalled with a smile. "I said this better not happen again or I'm selling the boat and getting a Winnebago!"



Bravo, Kelly Peterson 46, Seattle — Some trips down the coast are more exciting than others. Count *Bravo's* among the former. Adam and Cindi Kerner left Seattle's Shilshole Marina bound for Coos Bay with crew Mike and Kirk aboard. Adam, Cindi and Mike had taken seasickness meds, but Kirk, an experienced offshore racer who'd never been seasick in his life, chose not to. Unfortunately, a beam sea proved too much for Kirk's iron stomach and he succumbed.

"We were concerned about him getting dehydrated," said Adam, "so we made sure he was getting plenty of electrolyte replacements." Then in the middle of the night off the Oregon coast, Mike called Adam down below — Kirk was passed out and lying halfway in the head, half out. "At first we thought he might have fallen and hurt his back," recalled Adam, "but when I saw the little cartoon Xs in his eyes, I realized we had a real problem."

Assuming Kirk was suffering from extreme dehydration, they headed straight for Newport. Cindi escorted him to the hospital, where he was put on two IVs. But when he didn't perk up — which usually happens almost immediately — the ER staff did a blood work-up. That's when the red flags started flying.

"His blood hematocrit level was half what it should have been — he was bleeding



Kir-Tidou, Privilege 495, Les Sable d'Olonne, France — For the past eight years, the Bonnefille family — parents Thierry and Dulce, and kids Mathieu and Eva — have cruised halfway across the globe aboard *Kir-Tidou*, and have loved every minute of it. "We left when Matt was six and Eva three," said proud papa Thierry. The Bonnefilles left their then-homeport of Belgium in '02, and took their time exploring their way across the Atlantic to Brazil. "We didn't want to miss anything," Thierry laughed.

But not all of their journey has been by boat. Once they arrived in South America, they rented an RV to explore inland. "We spent six months in the motorhome exploring Argentina, Bolivia, Peru, Chile," Thierry said. "We even drove the motorhome onto a ferry and 'sailed' the Patagonian Canals."

Having slowly worked their way north through the Caribbean, the family spent two months in Cuba. "For us, it was a fantastic trip," Thierry said. "We met incredible people, and found they have top-notch education and medical facilities." But he noted that life is very difficult for Cubans. "The man who cleaned my boat for very little money was a nuclear engineer."

From there, the Bonnefilles sailed to Puerto Rico, Colombia, and San Blas before transiting the Panama Canal this February. They took a little time exploring Costa Rica and Mexico before heading off for Hawaii — a 32-day journey — then to San Diego. "Schooling is very difficult when we're underway," Thierry reported, "so we try to not do many crossings."

As it is in every family with teens, getting the kids to do schoolwork takes dedication and discipline. "Every morning is school-time," Thierry said, kindly overlooking the fact that we were providing quite a distraction for the kids, now 14 and 11, respectively. "Dulce teaches languages and arts, and I teach sciences."

Kir-Tidou spent a few months in San Diego, where the family made many friends, before heading up the coast to the Bay. They planned to stick around the area for a month before heading back to San Diego — if the boat doesn't sell by then. "The kids want to go to a real school and meet other kids," said Thierry. They plan to sell the boat (see *Kir-Tidou's* ad in this month's *Classy Classifieds*), then return to Portugal, Dulce's home country and where they have a house. "When Eva goes to university," said Thierry, "we'll buy another boat and continue travelling."

internally," Cindi said. Kirk was packed up into an ambulance for the hour-long drive to a bigger hospital. "They had to give him four units of blood on the trip and four more in the operating room."

Once in the OR, surgeons repaired four tears in blood vessels between the esophagus and the stomach — all caused by violent vomiting. "The doctor said that if we'd continued on to Coos Bay, we'd have arrived with a dead crewmember," recalled Adam with a shudder. *Bravo* headed for the Bay with no more drama to report.

As for their future cruising plans aboard *Bravo*, which they've owned for eight years, Adam and Cindi are open. Cindi, a hospital pharmacy director, doesn't retire until November — she took a month off to make the trip south — so she and Adam, a retired architect, will wait until December to head south of the border. "We want to see Central America, but otherwise have no hard and fast plans."

The one thing they are firm on is their philosophy on life. "I was diagnosed with breast cancer in June," Cindi said. "I had radiation therapy and I'm fine, but it, coupled with Kirk's situation, really cemented the fact that, no matter what you want to do, you should just get out and do it." Amen to that!



PASSIN' THROUGH



Mia II, 43-ft Laurent Giles-designed woodie, Victoria, B.C. — Paul Smulders and Julie Newton aren't strangers to the Bay. Not only did Paul, a Dutch boatbuilder, spend time here 30 years ago aboard the homebuilt 53-footer *Puppeteer*, but he and Julie passed through five years ago on their first southbound trip together aboard *Mia II*.

"We spent a year and a half fixing stuff the previous owner Bob had done — we call them 'Bob Jobs' — and finally left in the fall of '05," said Julie. But Julie had been working on more than the boat in that time. As a custom shirtmaker and alternative transportation activist, Julie's life had been, until she met Paul, landbound. "I knew if I wanted to go on this trip, I had to reinvent myself."

Excited about the future, Julie became even more frugal than she already was. "I would walk rather than spend \$2.25 on the bus because I knew how far that would go

The Simple Choice For Fresh Water

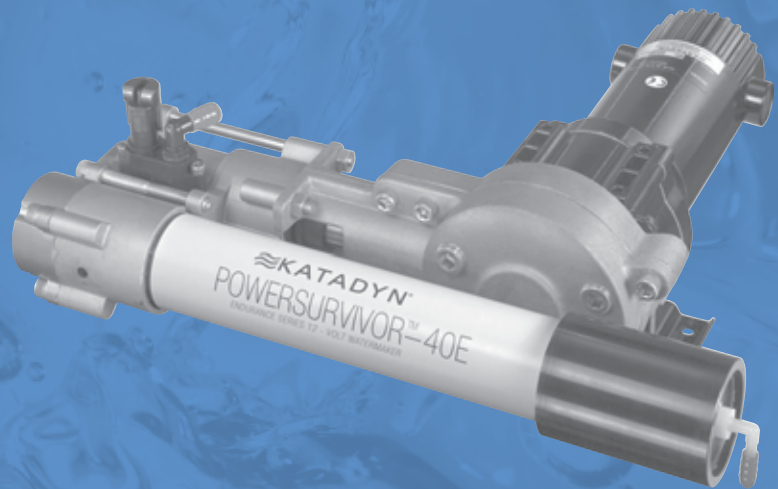

Katadyn PowerSurvivor Watermakers are small, reliable and easy to maintain. That's why they are the best selling watermakers for cruising sailors.

Making your own fresh drinking water is a great addition for the independent lifestyle. Katadyn watermakers are simple in design, moderately priced and have proven reliability.

For about \$3,400, it's a great way to improve life onboard.

800.755.6701 • www.katadyn.com

KATADYN[®]
MAKING WATER DRINKING WATER

in Mexico," she noted. The couple credits their frugality with stretching out their cruising time.

Once they left Sausalito in '05, Paul and Julie took their time heading south to Baja, then on down to Acapulco. "It got too hot, so we moved on."

They were able to get a 21-day permit to visit the Galapagos but, shortly before their permit expired, they were hit by a service vessel. "Most people only get to stay for three weeks," laughed Julie, "but we got to stay for two months!" Of course, they spent four months in Ecuador effecting repairs, but that also served to prepare the boat for the rough trip down the coast of South America to the channels of southern Chile.

"We spent 21 hard-core days beating against the current down the coast of Peru," said Julie, noting that they didn't stop because they'd been told Peru wasn't cruiser friendly. "Since then, we've heard otherwise."

Once they reached Chile, the pair say they were treated like royalty. "But we bucked, *bucked* down that coast,"

recalled Julie. "We could only move on days with no wind, otherwise we had to stay put." In all, the trip down to Puerto Montt at the northern end of the Patagonia Canals took 54 days.

Exploring the canals took another month or two — "There is nothing, absolutely *nothing* there in the way of civilization," said Julie — before arriving in Ushuaia. They spent the winter moving between Ushuaia and Puerto Williams,

"I'll take the title of 'cruiser' — it's better than staying ashore!"

with Julie even getting a job teaching English.

During their stay, Julie grew concerned that she had breast cancer. "A walleyed gynecologist in Ushuaia — I didn't know which eye was the good one — said I was ok, but I knew it wasn't right." So once spring arrived, *Mia* found herself heading back north to Puerto Montt, dodging bergie bits as she went.

Paul and Julie then headed to the Marquesas, where they spent a couple months cruising before reaching to Hawaii. They spent another couple months exploring the islands, then made the three-week leap to Canada in May '08.

Back in the land of socialized medicine, Julie found out that she did indeed have cancer. She ultimately underwent a mastectomy, radiation, and chemotherapy. "The whole nine yards," she said. "But I talk about it in the past tense now. It was two years of hell, but getting here yesterday was wonderful — it's still hitting me that we're going cruising again."

Paul and Julie planned to stay on the Bay for a couple of weeks before heading south. "We'll be out for five years, at least," said Paul. "Maybe indefinitely." They plan to cruise the South Pacific, New Zealand, Tasmania, and all the spots they missed their first time out.

"Someone at Galilee Harbor called me a 'cruiser', not meaning it in a bad way," noted Julie. "I'll take the title of 'cruiser' — it's better than staying ashore!"

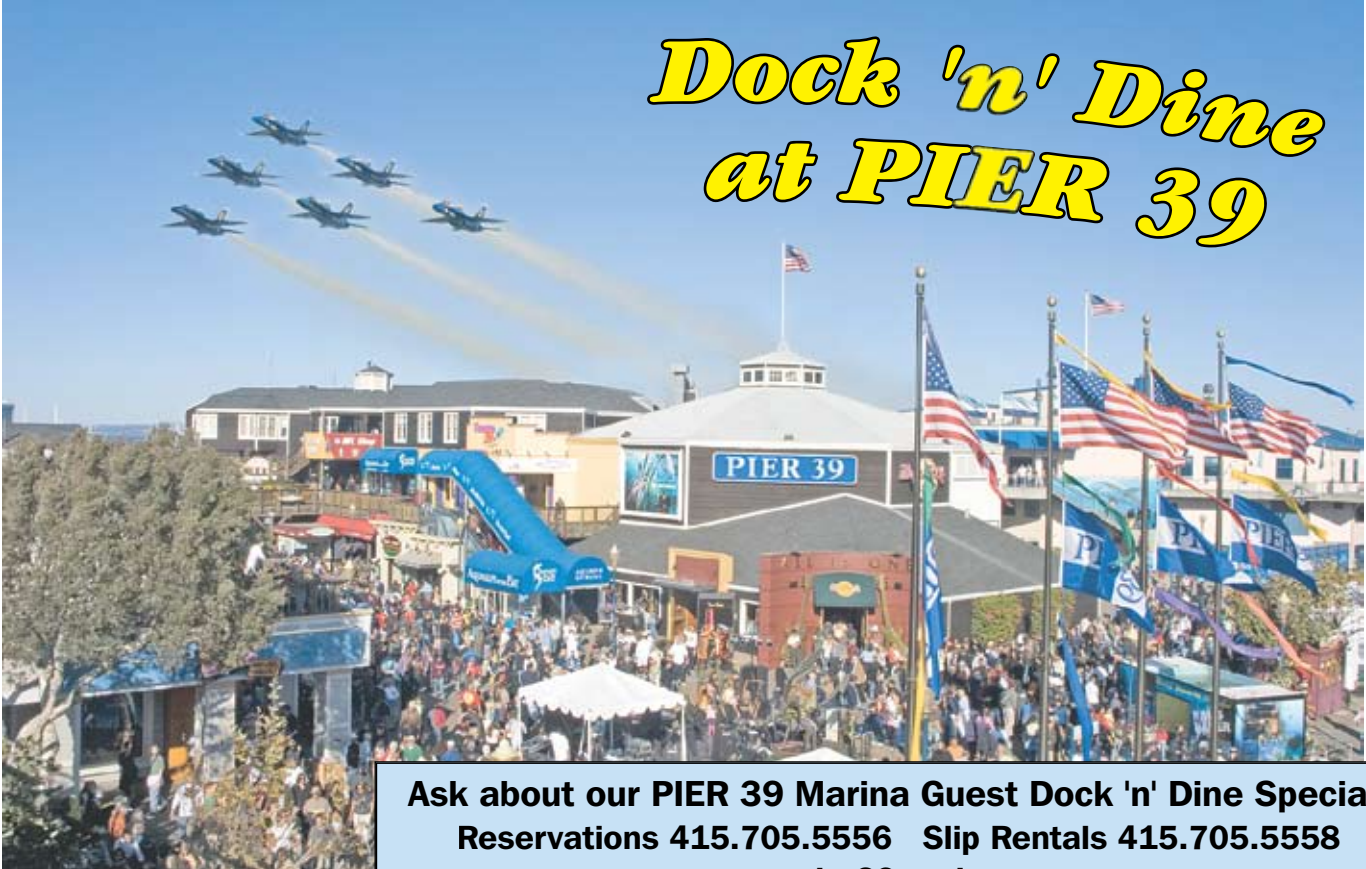

**Dock 'n' Dine
at PIER 39**

Ask about our PIER 39 Marina Guest Dock 'n' Dine Special!
Reservations 415.705.5556 Slip Rentals 415.705.5558
www.pier39marina.com

TOP TEN TIPS

Given the fact that the global and U.S. economies have been struggling, we asked noted sailing skinflint David Wegman for some tips on circumnavigating the economic downturn by cruising on the ultra cheap. Wegman built his 32-ft Block Island schooner *Afrigan Queen* 30 years ago, did an eight-year circumnavigation, and for the last 12 years has been cruising the Caribbean six months a year.



The Ultimate Recycler with his art on a bit of his old mainsail.

Wegman is the perfect sailor for the task, because he has always carried sailing thrift to the extreme — even during boom times and even while spending months at a time at St. Barth, potentially the most expensive island in the Caribbean. “Yeah, I’m cheap,” he thunders proudly. “I’m even cheaper than Jim Green, and he and his wife Anna started the second of his three circumnavigations aboard his wooden 10 Meter *Tango II* with just \$150.”

Despite being ultra thrifty, Wegman has countless friends in some of the nicest places on earth between Bequia and Maine, picks up new ones like dogs do fleas, hosts free art and music schools wherever he goes to encourage people of all ages to get in touch with their creative side, and has more fun in life than just about anyone.

The concept of this article was for Wegman to give us his Top Ten Tips For Circumnavigating the Recession on the Cheap, but as we were dealing not just with a professional artist, but with an artist who sees humor in just about everything, it came as no surprise that he quickly ran off the canvas. Nonetheless, here are his tips:

Lord only knows how long someone else used this chain before Wegman got it, but it's still holding strong.



1) Learn to Live Simply

“That means doing without all kinds of gadgets and stuff that cost money but always need repairing. I laugh when people ask me if I have a watermaker. My awning is my watermaker. I have a 30-gallon water tank and 10 gallons in jerry jugs, and that’s always been plenty for me — even during my circumnavigation. I don’t have a shower because they’re a big waste of space and water. When it’s time to wash up, I put my copper tea kettle on the stove for exactly four minutes, and take an outdoor shower. The water is warm, and I know the air will be warm because I only sail in the tropics.

“And what’s with these people who own boats that have heads with toilets, and galleys with sinks? I’ve got two buckets. The yellow one is for washing dishes on deck, the black one is to shit in — so you don’t want to mix them up. These ultra simple head and shower systems have worked just fine for me for 40 years, and I’ve never once had to clear a clogged toilet. In fact, most of the time I don’t even use the black bucket to take a dump in, as I’ve found a comfortable place to squat up by the windlass.

“While sailors probably waste the most money on useless electronic gadgets, a few of them are actually worthwhile. I’ve got no problem with a \$100 handheld GPS. In fact, I had one for 15 years until I couldn’t read the screen anymore. I’ll probably even get another one some day. And perhaps the best electronic thing I ever bought was my Icom 700 SSB radio. For during my circumnavigation, I could call home from places like Tonga via phone patches. The SSB is old now, but still works great.

“The electronic things that I think are the biggest wastes of money are knotmeters, wind instruments, depth-sounders and all the electronic crap like that. Who needs wind instruments when you can hang some yarn from the rigging? Who needs a depthsounder in the tropics where the water is clear? Sure, it might make sense to have one up north where the water is murky and it gets foggy, but who wants to sail up there? I used to have a VHF radio, but then the antenna got so corroded it fell off the mast and into the water. I didn’t think the VHF was any great loss. Somebody later gave me a handheld VHF, but I haven’t found

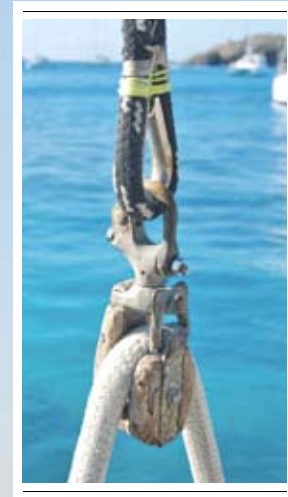

much use for it.

“And no, I don’t have an EPIRB. But I do have a life-ring with the letters ‘TFB’ stenciled on it. They stand for ‘Too Fucking Bad’ — which is perfect for anybody who falls overboard. You just can’t let yourself do that. And I don’t believe there’s any such thing as a ‘safety harness’. In the case of my schooner, she’s got so much rigging you’d have to be pretty damn clumsy to fall overboard. But I’ll tell you something that did scare me. I recently delivered a big Hunter from Key West to St. Martin, and the roller furling came undone in 40 knots of wind. I had to go forward, and I couldn’t find anything to hold onto up there. I was scared.

“When it comes to safety, my dinghy is my liferaft. If *Afrigan Queen* sinks, I’ll grab all the water I can and hop into the dinghy I built. Naturally, I’d also take my passport, whatever money I have — and probably my sewing machine. But water is the big thing, because I could easily rig some kind of sail on my dinghy and get somewhere pretty quickly, particularly in the Caribbean where the wind always blows.”

FOR CIRCUMNAVIGATING THE RECESSION



Spread; In Wegman's world view, we're all part of one big family. So when he does 'Sundays at Columbie' with his schooner, everyone is invited. Insets left; The 'Queen' doesn't have the latest blocks or winches. Inset right; The 'Queen' as a children's playground.

2) Never Pass a Dumpster Without Jumping In — Or At Least Taking a Look

"All the rigging on my boat came from boatyard dumpsters. Normally you wouldn't keep the same standing rigging for 30 years, as I have done, but all my stuff is oversized, so I figure it's still good.

"Almost all of my original sails came from dumpsters, too. The only sail I added prior to my '89-'98 circumnavigation was a headsail I bought for \$1,000 from sailmaker Manfred Dietrich in St. Thomas. I did a lot of handwork on that sail to keep the cost down. But in the end, the sail didn't really cost me anything. In fact, I made money on it. For after my circumnavigation, I cut the sail into 70 panels of about 16 inches by 24 inches each. I made sure each piece had a grommet or bit of bolt rope to give it that nautical feel, then I silk-screened a copy of one of my paintings on them, and topped it off by dating and signing them. I then sold them for 25 euro each — which back then was about \$35 U.S.

— or a total of about \$2,000. Just this year I cut up my mainsail from '86. I'll get another 70 panels, or about another \$2,000 out of that. 'Optimum recycling' is what I call it when you get complete use out of something, then sell what's left for 100% more than you paid for it.

"I don't pass many flea markets either, as you can find good deals at them also. But nothing beats boatyard dumpsters. A long time ago, I found a \$3,000 cello in a dumpster on St. John in the U.S. Virgins. It was too big for my schooner, so I cut it down to a stand-up bass. I take my bass to all the jams — although I sometimes bring my guitars and harmonicas, too. Hey, someday you got to see the guitar of mine that Keith Richards autographed on New Year's Eve of '00 at Foxy's on Jost van Dyke. Normally you autograph the face of a guitar with something soft like a felt pen, but we'd been drinking quite a

bit and all we had was a ballpoint pen. Keith wasn't shy about digging into the face of the guitar with that pen either. But we had a great time playing together for hours that night.



"I don't ever buy anchor chain either, because I can find that for free. When most sailors see their chain getting a little rusty, they freak out and buy new stuff, leaving the old chain lying around in the boatyard. As long as the links are fat, I'll use the chain. Whenever my current chain gets close to needing to be replaced, I just keep my eye out on the docks and in the yards. It's never hard to find free chain. Wait a minute, I now recall once paying \$100 for some anchor chain — but it was \$600 worth of chain."

3) Engines and Transmissions Don't Have to Be Expensive

"Thirty years ago, my boat started out with a used two-cylinder Yanmar diesel that I paid \$700 for. After using it for 30 years, I'm now selling it for \$800. You see, I upgraded a few years ago when I heard about a guy in the British Virgins who had a 3-cylinder Yanmar diesel from a genset. The cheapest new Yanmar diesel is \$5,000, and that's for a tiny one. But I got this great used one for only \$1,500. I just threw it on deck and left it at Manfred's sail loft until I hauled my boat the following season. Meanwhile, while checking out a junk pile at a boatyard in St. Thomas, I found a transmission for the engine. The yard owner told me it was mine for the taking. It took a little work to adapt the transmission to the engine and to get everything to fit,

Wegman, seen here with Shaliz Koleni of Marin and the skull and femur of Kenny, a long dead sailor, never gives up on old friends.



TOP TEN TIPS

but the combination has worked really well.

"Not that I waste much money on diesel. After all, I've got a sailboat, so I sail. Besides, what's the rush? And the few times I do use the diesel, I run the engine at very low speed, burning hardly any fuel at all. I cruise six months a year, during which time I burn a total of about eight gallons."



Wegman's Aries vane is a loose as they come — and thus works great.

4) Don't Spend More Than About \$150 On Your Dinghy/Outboard.

"I designed my own rowing dinghy in a couple of hours by cutting the cardboard cover of a notebook into 12 pieces and taping them together to create a 12-inch model of what I wanted. Then I lofted it onto graph paper. The only materials you need to build a dinghy like mine are three sheets of quarter-inch ply, sawdust, epoxy, and some drywall screws. It only takes three days to build a dinghy, and that's not even working all day. I had my first one for 15 years, and I've had my current one for four years. And anybody who knows me knows that I don't baby my dinghies, so they are super durable.

"I don't want to brag, but my dinghies are the best you'll ever find. In fact, if you build one like mine, you won't even want an outboard. I had a British Seagull outboard once, but it wasn't worth the trouble. And I'm speaking as a guy who used to build dragsters from scratch behind the back of my dad's machine shop. No, I always row.

"It takes me 15 minutes to row a mile, and it doesn't cost me a cent. The nicest part is that I don't have to listen to a

Wegman's rowing dinghy may not be finished to yacht standards, but it's cheap, functional and durable.



noisy engine, smell a stinky engine, or go to the gym to keep from going into cardiac arrest — like people with outboard-powered dinghies. They'll be going in for heart surgery while I'm rowing back to my boat, that's for sure. You know how I'll know when my sailing days are over? When I can't row between my boat and the shore. But I'm only 65, so I've still got a lot of sailing left in me."

5) Know How to Fix Stuff

"As I mentioned, I grew up around a machine shop in the Midwest and built a dragster from scratch, so I became familiar with and confident with all kinds of tools and techniques. They have all served me well on boats. Family farmers have always had to know how to fix just about everything they own themselves, which is why they always have an easier time cruising than do retired doctors, lawyers and accountants. Let me give you some examples.

"I paid \$400 for an Aries windvane. It's a really great piece of equipment even though I've had to rebuild it from time to time. The Aries vanes are famous for the bushings freezing up, but that's because the Teflon bushings are too tight. The bearings have to be loose! So a lot of folks who think their Aries are no good or are broken just need to take the shaft out and enlarge those Teflon bushings. My Aries is 25 years old and works like it's brand new because I keep the bushings as loose as an old pair of shoes.

"I've got three anchors: a 60-lb CQR, which is the big mama, a little Bruce lunch hook, and a big Danforth. I didn't buy any of them. The Bruce was bent, but all I had to do was put it in a vise and straighten the shank. Another anchor had been thrown away because of a loose fitting. I welded it up in a few minutes, and it was as good as new. I didn't have to fix the third one, as somebody just gave it to me. You'd be surprised what other sailors will give you when they're replacing stuff — and so many sailors replace stuff for no good reason.



"One of my best fix-its was in Thailand. When I got there in '96, my wood masts were so rotten that I sawed them off at deck level and let them fall into the water. I wasn't sure how I was going to replace them, but then somebody told me there was a Proctor aluminum mast in a ditch next to Dim's Dine and Dance, which was Tristan Jones' old hangout at Ao Chalong Bay, Phuket. The only problem was that the mast was curved like a banana. But I dragged the thing up to a nearby expansion bridge, tied each end of the mast to the bridge, and started to work on the bend with a Spanish windlass. After two days, the mast still wasn't straight, but it was reasonably close. So I put it in my dinghy and floated it out to *Afrigan Queen*. The only problem was that it was still five feet too short for the mainsail. I solved that problem by carving a piece of wood the size of the interior of the mast and using it as the step. That was in '95, so it's been working fine for 15 years. And that included lots of 40- to 50-knot winds off the coast of South Africa."

6) Always Anchor Out — If You Can't Get A Free Berth.

"For example, when you pull up to the yacht club at Richard's Bay in South

FOR CIRCUMNAVIGATING THE RECESSION



Wegman's Sunday at Columbie aboard 'African Queen' has a mild resemblance to neo-impressionist Georges Seurat's 'A Sunday afternoon on the Island of La Grande Jatte', wouldn't you agree?

Africa, they give you a free bottle of champagne and a free berth for a month. That's the way it should be everywhere! While there, I met a guy who needed his two Wharram charter cats painted to look 'native'. So I painted African symbols on them for \$1,000. That was a good thing, because I'd arrived at Richard's Bay with zero money. The painting job paid for my ticket back to Maine for the summer. But something like that always works out.

"And if you have to leave your boat while you return home for the summer, don't pay extravagant slip fees. While in Borneo, for example, I heard about an old Muslim guy with a dock at Lumatt who was supposed to be reliable. So I met him, and he said he'd stay on my boat for \$1 a day. When I got back six months later, my boat was just fine. By the way, after leaving the boat with him, I took the train up to Chang Rai and Chang Mai in northern Thailand, where I loaded up on inexpensive sarongs that I took back to Maine that summer and sold for a healthy profit.

"During my circumnavigation, I left my boat for long periods in Costa

Rica, Tahiti, New Zealand, Borneo, and South Africa — and I never had to pay more than one or two dollars a day. I know this was a while back, but if you're patient and ask around, you can find great deals. The only problem I had leaving my boat anywhere was in Costa Rica. When I returned, I shook out a sail bag and a bushmaster snake slithered out of it and chased me down the bowsprit.

"When I go

to the States for the summer these days, I leave my boat on a mooring at Coral Bay, St. John, U.S. Virgins. I've got a lot of friends there, so they look after her a bit. But if there's a hurricane and she gets destroyed, well, her time will have simply come. I'm not going to worry about it."

7) Keep Your Haul-Outs Cheap By Doing Your Own Work and By Working Quickly

"Maintenance on my boat, which I cruise in the Caribbean six months a year, costs me \$500 a year. I haul every two years and spend \$1,000. Before I haul out, I go to Sea Chest in St. Thomas and buy a gallon of Motar epoxy topsides paint for \$35. I paint the topsides of my boat every two years whether she needs it or not. Now a lot of folks will pay \$300 a gallon for bottom paint. Not me. I look up the rasta guys who work in the boatyards, because when they paint

a boat bottom, they always have a little left over, and they dump it into a five-gallon drum. I give them \$100 for that five gallons of mongrel bottom paint, and slap it on. During the haulout, I also put in a new cutlass bearing, which is about \$70, and maybe \$30 in zincs.

"But to be thrifty, you have to do your own work, and you have to work hard, because the cost of lay days will kill you. I mean it. There's no dicking around during a haul-out. You work sun-up to sundown. I do my haulouts in four days, and you shouldn't take any longer."

8) Don't Forget The Sewing Machine

"Way back when, I bought a hand-crank Singer zig-zag sewing machine on a lark for \$20. There wasn't much foot tension, so it wasn't good for much more than dresses. So I put copper tubing over the shaft and slide to beef up the tension so I could use it on sails, awnings, dodgers, side curtains, cushions and I don't know what else. It's now strong enough to sew through four or five layers of sail material, but you need an 18-gauge needle and polyester thread. The 12- and 14-gauge needles and cotton thread are for ladies' dresses.

"You probably won't believe this, but that sewing machine has come in so handy that in 25 years I've never gotten around to putting it back in the box. In fact, as I said before, if I ever had to abandon ship, I'd get into my dinghy with water, my passport and money — and

Looking a lot like Mr. Natural, Wegman rides to his own colorful tune, both as a self-deprecating circumnavigator and an artist.



"I have no insurance!" Wegman shouts each time someone dives off the spreaders.



TOP TEN TIPS

that sewing machine!

"Another valuable item is my folding bike. I found mine in Key West and mailed it to my boat in St. John for \$40. It's really nice having a bike when you need to go to the laundromat, store, or just to explore. You just don't want to ride up hills."

9) Watch Where You Spend Your Money So That You Don't Waste It

"When I went around, I did it on about \$10,000 a year. Of that, \$2,000 was for food, \$3,000 was for the boat, and the remaining \$5,000 was for booze. Just think how little I could have spent if I didn't drink. But I do. If someone has \$1,000 a month, they can cruise and drink at happy hour every day of the week at all the places I've ever been.

"It's easy to eat inexpensively by just eating simple food and participating in lots of potlucks. If it's just me on the boat, I'll usually eat ashore at some inexpensive place. But for long passages, I'll stock up my schooner with rice, beans, tinned butter from New Zealand, and long-lasting fresh stuff like pumpkin

squash.

"During passages, I make a lot of bread on the stove-top. All you need is flour, molasses, oats, corn meal and whatever else might taste good in it. For example, a lot of times I'll throw chopped up onions, garlic, sun dried tomatoes or olives in my bread. I always like to try something new. Anyway, I got my bread down perfect. I usually use 1/3 whole wheat flour and 2/3 white. I cook it on

"Just think how little I could have spent if I didn't drink. But I do."

real low heat for an hour in one of those real cheap aluminum pots you get in Asia. After it cooks to a golden brown, you flip it over for half an hour. It's the best bread in the world — and a big staple in my passage-making diet.

"Fishing keeps the food budget down, too. I only fish when I'm on a passage, but I catch some big fish. I use the best — a Cuban hand reel, 200 feet of 500-lb test line, some wire leader, and a yellow feather on a chrome sinker with red eyes and two stainless hooks. You let out 150 feet of line, using a bike inner tube as a shock absorber with 15-ft of slack in the monofilament. When a fish hits, it stretches the inner tube, comes to an abrupt halt, and sets the hook. I've gotten some 100-pound tuna that way. No, I don't use a gaff. I just yank the fish over the low rail. Sure, about 20% get away or are taken by sharks, but I like the simplicity of my method.

"I also brew beer on my boat in five-gallon jugs. It takes 14 days. You bottle it in four days, and 10 days later you drink it from plastic Coke bottles. It's important to siphon it out of the five-gallon container to the plastic Coke bottles so you don't get any scum. It tastes delicious — even though I drink it warm because I don't have refrigeration."

Spud Point Marina

Just 50 miles from the Golden Gate

Want to get away from the traffic, noise and pollution in the Bay Area? Bodega Bay is the place for you (and your boat). Spud Point Marina has berths up to 80' @ \$8 per foot/month...

Enjoy the Fun, Sun and Salmon in Bodega Bay

1818 Westshore Road, Bodega Bay 94923 (707) 875-3535
spudpoint@sonoma-county.org spudpointmarina.org

FOR CIRCUMNAVIGATING THE RECESSION

10) Spend Most Of Your Time In the Less Expensive Places

"Polynesia is very expensive. The Philippines are very inexpensive — and they are just as beautiful. Dinner is a buck or two, and a beer is a buck."

11) The Other Side Of Thrift Is Making Money

"If you're doing a circumnavigation, there are always ways to make money. For example, I worked as a welder for two months on a barge in New Zealand. That was enough for my ticket back to Maine for the summer. During my circumnavigation, I would always sail for six or seven months, then come back to the States for the summers. I'd always bring exotic stuff back to sell.

"While doing my trip, I sold paintings and did other artwork. For example, while in Borneo I was hired to create posters discouraging the locals from killing fish with bombs and fertilizer. One was even presented to the President of Malaysia. I also wrote a book about Squeaky and Morris, two cockroaches who got thrown



Wegman admits that this bowsprit turnbuckle looks a little funky, but he says it's still plenty strong.

off a cruise ship in a bag of garbage and drifted ashore in Malaysia. It didn't make the *New York Times* Best Seller List, but I made some money.

"And remember, a few dollars in art supplies can bring big returns. I did a lot of paintings in pastels because they were easy to carry and work with. I would get \$700-\$800 dollars for each painting. And I don't want to hear any of that 'I'm not an artist' nonsense. I teach art for free just about everywhere I go. It's not hard. Some people mistakenly feel you need all kinds of fancy supplies and stuff. Baloney. My friend Bruce Hein of the

Seattle-based *Woodwind* does all his paintings using Rust-o-leum paint. They look terrific and he's sold a lot of them."

Laugh if you want at Wegman's ideas — we often do — but we can assure you that he doesn't just talk, he walks the walk. And having borrowed his self-designed and self-built dinghy, we're going to try to build one with him for ourselves next spring.

For the record, David Wegman has a studio over the famous Le Select Bar in St. Barth; an interest in Tallship Trading, which is a T-shirt silkscreen company in Coral Bay, St. John, U.S. Virgins; a studio in Key West; an RV in an orchard outside Saratoga, New York, where he grows tomatoes; and a commune-like place in Maine he bought with 10 others from the Caribbean many years ago. During this year's Carnival, Wegman came dressed as Aunt Jemima, wearing blackface and a mammy outfit he made using his beloved sewing machine.

— *latitude/rs*

STAY FOCUSED WITH OUR EYE SAFE NO-STING FORMULA



Z Blok sunscreen's new non-greasy formula will not burn or irritate your eyes. So you can concentrate on winning the race or just enjoying a great day on the water. Z Blok is also fragrance free.

Z Blok is the official sunscreen of the PUMA Ocean Racing Team. Skipper Kenny Read said:

"The UV protection is excellent. Every member of the team is a true believer. We have put Z Blok to a tough test that few others can. Most importantly, we have experienced no eye stinging or irritation and we use it every day."

Visit zbloksun.com
or call 508.995.9511

**OFFICIAL SUNBLOCK OF THE
PUMA OCEAN RACING TEAM**

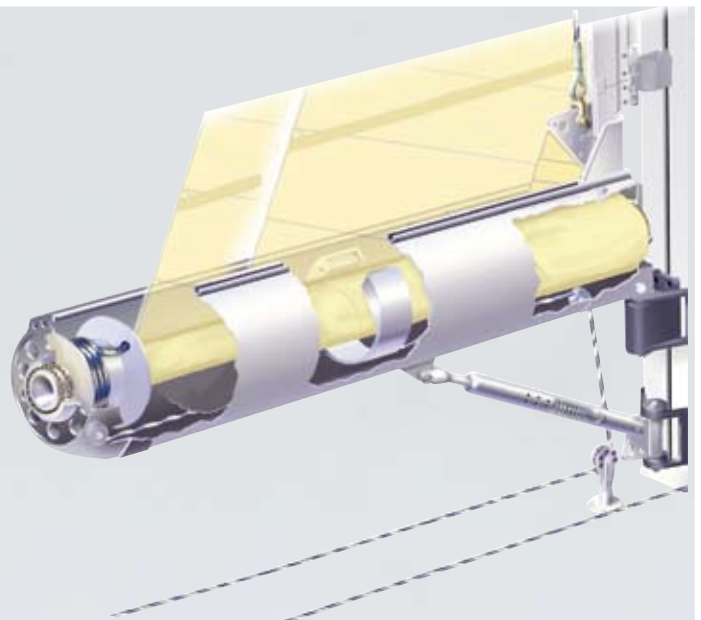

FURL ON THE FLY.

With Schaefer's innovative boom furling system and patented articulating sail track, you can reef your main on any point of sail - all from the safety of the cockpit. Trouble free reefing and furling - just what you would expect from Schaefer Marine.

SCHAEFER
LEGENDARY STRENGTH

508.995.9511
SCHAEFERMARINE.COM

BAJA HA-HA PROFILES, PT II —

When we reached the entry deadline for this year's Baja Ha-Ha cruiser's rally late last month, we were struck by the irony of the fleet totals. Despite the dour recession, last year's total of 193 was an all-time high, and this year's 188 is a close second.

But perhaps those numbers have more to do with pragmatism than irony. The way we figure it, the 2010 fleet members probably belong to one of two groups, the first being comprised of folks who've been working toward the goal of long-term cruising for so long that virtually nothing is going to stop them from realizing their dreams. And we'd guess that the others are sailors who may not have much cash flow, but figure, "What the heck? The boat's paid for and it's a whole lot cheaper to live in Mexico, so let's set a course for *mañanaland*."

As in years past, 2010 Ha-Ha'ers come from a wide range of backgrounds and the boats they sail on are equally diverse. You'll meet a slew of them here, in this second installment of mini-profiles, and the remainder next month.



Mexico awaits Leanne and Jack of 'Red Sky'.

Red Sky — Moody 54
Jack & Leanne Hembrow
 Brisbane, Australia

Noteworthy: This Aussie couple has already done several South Pacific rallies. After the Ha-Ha they plan to eventually transit the Panama Canal and join the ARC Europe Rally in May 2011.

Content — Perry/Litton 47
William Holmes & Paula Collins
 Homer, AK

Quote: What's the most interesting thing about this 1979 Robert Perry-designed cutter? "It's paid for!"

Windfall — Maple Leaf 42
Sam & Nancy Cockrell, Portland, OR
Noteworthy: For Sam and Nancy the



Sam and Nancy will 'go around' on 'Windfall'.

Ha-Ha will be the beginning event in their proposed circumnavigation. After cruising Mexico, they'll head to the South Pacific.

Sudden Stops Necessary —
Beneteau First 38s5

Chet Chauhan, San Francisco

Quote: "I hope to be the first British, Kenyan-born sailor of East Indian descent to sign up for the Ha-Ha 2010."

'O — Davidson 44
Robert & Bobbie Kuschel
 Redwood City

Noteworthy: This aluminum-hulled, Laurie Davidson-designed, fractional sloop is a former racer that supposedly helped break the IOR rule.



Robert and Bobbie's 'I'O' is Aussie-built.

Sulaco — Swan 371

Glenn Brake, Marina del Rey

Quote: "The last time I went down the Baja and back up was in a Columbia 24 with a 6hp outboard. This trip should be more friendly."

Symphony — Fuji 32

Joel Tuttle, San Francisco

Quote: "Realize your dream of casting off and sailing into the unknown, knowing that in years to come today's dream will be tomorrow's reality."



Mazu — Outbound 46

Mel & Elaine Bryson, Rainier, OR

Noteworthy: The Baja Ha-Ha will be the initial leg of the realization of a long-delayed dream that originated in Lahaina, Maui in '78; namely, to sail to the South Pacific on an open-ended voyage. Let the adventures begin!"

Double Dharma — Hunter 466

Dale & Dena Snearly, San Leandro

Quote: "Shift change! We have retired and are beginning our new life as full-time cruisers exploring the beautiful waters of the world."

Coppertop — Bayfield 32

Paul Moran, Brookings, OR

Noteworthy: After the rally, Paul plans to do a Pacific circuit: the Puddle Jump to French Polynesia, north to Hawaii, then home to the Pacific Northwest.

Wind Rose — Cabo Rico 40

Walter & Patricia Simmons
 Los Angeles

Quote: "The *Wind Rose* has taken good care of the Simmons family. She has helped us to weather storms, strengthen family ties, nurture a sense of adventure, and renew our faith. Now she will show

SAILING TO SUNNIER LATITUDES



Above: The fleet rides a fresh breeze south from Turtle Bay under sunny skies. Spread: Hikers stretch their sea legs during the rest stop at Bahia Santa Maria.

Island Time — Seawind 1000 cat
Larry & Nancy Robertson
Dana Point

Quote: "I'm hoping this is a good experience for my wife," says Larry, "so she will want to really go cruising when I retire."



This crew is eager for some 'Island Time'.

Barramundi — Seawind 1000 cat
Steve & Pam Ellsworth
Newport Beach

Quote: How do they describe their attitude toward the Ha-Ha? "The 3 'F's: Friends, fun and frickin' warm weather!"

Santorini — Mariner 48
Dawn Fleming & Thomas Clifford
Wilmington

Quote: "We saw this boat for sale at a boat show in 2001, then hung the broker's flyer on our refrigerator, dreaming about owning her one day. Five years later, we tracked down the owner and found out he had her listed for sale. We bought her and sailed her to her new home in SoCal. So dream big dreams. They do come true!"

Seasilk — Hylas 46
Craig Blasingame & Sue Steven
Coronado

Quote: "We've looked forward to doing the Ha-Ha ever since we bought Seasilk as our liveaboard home four years ago."

Bonnie Lass — Catalina/Morgan 440
Bill & Lorell Alexander, Tiburon

Noteworthy: Bill and Lorell have no plans to return home. Instead they'll "just keep going south."

Setting Sun — Pearson 323
George Johnstone, San Rafael

Quote: Why did George enter the Ha-

us the world beyond Southern California."

Sonrisa — Baba 40
Scott Bowen
Green Cover Springs, FL

Quote: "I've waited for this part of my life to start since I was 12 years old. Now, it's all about the journey ahead. I've discovered that it's never too late to



The 'Sonrisa' crew is all smiles.

have a happy childhood. But the second one is up to me, nobody else."

Rosebud — Cal 36
Greg Rodgers, San Pedro

Quote: "Rosebud is hull #1 of this Cal

36 design; still going strong and looking to stretch her legs."

Dodger Too — Tartan 37
Leif & Jackie Watson
Edmonton, AB, Canada

Quote: "We built her in '83, spent two years in the Med, crossed the Atlantic, and now have spent a long time on the West Coast. She has looked after us well and we are sure she will continue to do so."

C'est La Vie — Amel Mango 52
Bob Bohn, Anacortes, WA

Quote: "Going where the weather suits my clothes."

Otter — Westsail 32
Greg & Joyce Parfitt, Scappoose, OR

Quote: "We have dreamed of this first leg of our trip for so many years. It's so exciting that it's finally becoming a reality instead of a dream."

La Condessa del Mar
Herreshoff 65 schooner

Quote: "La Condessa is a comfortable, heavy sea cruiser and needs to get over being dock-bound."

LATITUDE / ANDY

BAJA HA-HA PROFILES, PT II —

Ha? "It is too cold here!"

Gratitude — Island Packet 485

Mike Irwin, Alamitos Bay

Quote: "Any time spent sailing is not deducted from your life expectancy."

Abagwit — Niagara 35

**Werner Landry & Allison Sherwood
San Diego**

Noteworthy: The name *Abagwit* is a Micmac Indian word meaning "in the cradle of waves."

Taverna — Catalina 470

Sal & Debbie Vitale, San Francisco

Quote: "We're finally getting underway!"

Fixin' To — Hylas 44

**Jim & Sharon MacIntosh
San Francisco**

Noteworthy: In 2002 Jim passed a Catalina 22 that was advertised for sale on a country road in central Oklahoma, and his sailing passion was sparked to life. He named the boat *Sudden Impulse* and took sailing lessons on Oklahoma

lakes. Sharon was coaxed into First Mate training and the dreams began.



An impulse led Jim and Sharon to 'Fixin' To'.

Phambili — Given 45

**Tommy Lorenzo & Fiona Coleman
Victoria, BC**

Noteworthy: This Ron Given-designed hull was built on Saltspring Island by Bill Moseley, who sailed her to New Zealand

and back with his wife Dominique.

Seabird — Swan 51

Lou & Marge Freeman, Ventura

Quote: "This is our annual 'push the boat' opportunity." *Seabird* has done three previous Ha-Has.

Intuition — C&C 37XL

Ron & Connie Holbrook, Tacoma, WA

Noteworthy: In addition to doing the '05 Ha-Ha, *Intuition* has done three Chicago-Mac races, the Van Isle 360, and numerous Swiftsures.

Ticket — Beneteau 47.3

Rick Niello, Sausalito

Noteworthy: Rick started sailing at age 10 and still loves it.

Wyspa — Baltic 55 DP

Roger Waterman, Del Mar

Quote: "Life is for living!"

Touchrain — Ericson 38

Michael & Jan Wilson, Olympia, WA

Noteworthy: *Touchrain's* previous

Let Hydrovane sail you home safely.



▲ Polar circumnavigator Adrian Flanagan.

YACHTING MONTHLY October 2006
100 best bits ever

Latest ARC survey – Hydrovane again the most popular wind vane.

Totally independent self-steering system and emergency rudder... in place and ready to go.

WWW.HYDROVANE.COM



HYDROVANE
SINCE 1968

SURVIVE YOUR DREAM

info@hydrovane.com PHONE 1.604.925.2660

Welcome to Mazatlan...



Marina El Cid style!

A CRUISER'S PARADISE IN THE HEART OF MEXICO'S LUSH TROPICAL COASTLINE AND BEAUTIFUL ISLANDS

Complete, Modern Amenities, Including Marina-Wide High Speed Wireless Internet Connections!



www.marinaselcid.com
011-52 (669) 916-3468
marinaelcidmazatlan@elcid.com.mx

The Cruiser's Home in Mexico

SAILING TO SUNNIER LATITUDES



Jan and Michael of 'Touchrain'.

owner bought her with his earnings from acting in *Free Willy*. He had the only speaking part at the car wash scene!

Bright Angel — Mason 44
Bob & Linda Hargreaves
Olympia, WA

Quote: "We've sold the house, sold the furniture, sold the kids (oh wait, they left on their own) and moved aboard. . . The Ha-Ha will be the first, giant leap into our long-awaited and much-anticipated new cruising life!"

Hand Full — Islander 34
Tiffin & Neil Rife, Half Moon Bay

Noteworthy: When approaching from astern, you'll know it's *Hand Full* ahead of you, as she bears the handprints of all four crew members on her transom.

Dragon's Toy — Island Packet 37
Tom Kohrs & Cary Purvis, Freeport

Quote: "Fate has had us crossing each other's path for the last 15 years. We both did the '06 and '08 Ha-Ha's but never met until we signed on to do

Tom and Cary of 'Dragon's Toy'.



a delivery from Panama to Florida early last year. We have been inseparable ever since."

Moonbeam — Seidelmann 299
Scott Dobias, Long Beach

Quote: "Moonbeam may be small, but she's packed full of treasures."

Ohana — Beneteau 45f5
Steve Hocking & Marika Edler
Eagle Point, OR

Noteworthy: To Steve and Marika the Ha-Ha is synonymous with romance. They got engaged during the '08 Ha-Ha.

Serendipity — Gozzard 36
Hugh & Anne Jenings
Port Ludlow, WA

Quote: "Time to quit talking and just do it."

Kanga — Valiant 40
Jim Hassberger & Jeanne Harvey
Coos Bay, OR

Noteworthy: Jim and Jeanne plan to winter in Mexico, and are strongly con-



Remote Satellite Systems

888.989.8199 • www.remotesatellite.com

**GLOBAL COMMUNICATION BREAKTHROUGH
 JUST IN TIME FOR OFF SHORE CRUISING!**



Isat Phone Pro

- Special equipment priced as low as \$495
- World wide coverage
- Airtime as low as \$19.90 per month and \$0.80 per minute
- We can ship today!



Sailor 150 Fleet Broadband

- Broadband Internet at Sea
- Data and Internet capability
- Voice

BAJA HA-HA PROFILES, PT II —

sidering doing the 2011 Puddle Jump.

Rocinante — Beneteau 473
Cooper & Phil Patterson, San Diego
Quote: "Slow is smooth, smooth is fast!"

Sound Effect — Dufour 385
Jim & Connie Merritt, Tacoma, WA
Quote: "After a decade of sailing in Seattle we want to see how good we look in sunglasses!"

Sterling — Catalina 34
Byron Cleary, Sausalito
Quote: "If you are first, you are last!"

Enchantress — Liberty 49
Melinda Morgan & Steve Cross
Port Ludlow, WA
Noteworthy: This may be the only boat in the Ha-Ha fleet with a hand-carved figurehead.

Music — Nordic 44
Gail Lapetina & John McCartney
Bellingham, WA
Quote: "After years of sailing Washington, Canada and California, we're

looking forward to warm balmy breezes and margaritas!"



Gail and John will make beautiful 'Music'.

Tara — Caliber 28
Jonathan Neely & Shannon Walker
San Francisco
Quote: "If there is clear water, good beer, and great sailing, then count me in!"

Moonbow — Crowther 38
Richard McCredle, Dana Point
Quote: "Sail Fast Live Slow."

JaneO — Privilege 39
Scott & Christine Emmons
Redwood City
Quote: "We're home-schooling our 17-year-old son. Are there any Algebra II teachers doing the rally?"

Peregrine Spirit — Ericson 380
Tony & Kathleen Van Houweling
San Diego
Quote: "Doing the rally as crew in 2002 was wonderful. But doing it on my boat in 2010 is a dream come true!"

Exit Strategy
Jeanneau Sun Odyssey 46.5
Steve Ginder, Dana Point
Quote: "Old guys rule!"

Magda Jean — Valiant 40
Michael & Katharine Bird, San Diego
Quote: "The rally will be the beginning of our life as rootless cruisers."

Legacy — C&C 34
Lewis & Willa Keizer, San Francisco
Noteworthy: Lewis is an independent (heretical) Bishop who plans to offer Sun-

Welcome to La Paz!



**IN DOWNTOWN
 LA PAZ**

Join us for the
BAJA HA-HA BEACH PARTY
 Thursday, November 18, 4-7 pm
 at Papas & Beer Beach Club

All new hardwood docks
 Dinghy landing with potable water
 New protective piling & sheetpile breakwaters
 Wireless Internet · and more!

Friendly, helpful, fully bilingual staff

TEL: 011 52 612 122 1646
 email: marinalapaz@prodigy.net.mx
www.marinadelapaz.com

Apdo. Postal 290, La Paz, 23000, Baja California Sur, Mexico



OUR ANNUAL
 FALL SALE ENDS OCTOBER 6!
 CALL ONE OF OUR
 PARTICIPATING LOFTS
 BELOW FOR A QUOTE!

Ullman
Sails

An Investment in Performance

<p>Newport Beach 2710 S. Croddy Way Santa Ana, CA 92704 Dave Ullman Bruce Cooper Erik Shampain Keith Magnussen Scott Poe (714) 432-1860</p>	<p>Marina del Rey/ King Harbor Mike George (310) 645-0196</p> <p>Ventura 3639 E. Harbor Blvd., #111 Ventura, CA 93001 Gary Swenson Deke Klatt (805) 644-9579</p> <p>Santa Barbara Ken Kieding (805) 965-4538</p>	<p>Santa Cruz Brent Ruhne Ruhne Racing (831) 295-8290 cell</p> <p>Arizona Bruce Address (602) 499-3844</p> <p>San Francisco/ Sausalito (Racing Sails Only) Robin Sodaro 466 Coloma St. Sausalito, CA 94965 (415) 332-4117</p>
---	--	---

Visit our website:
www.ullmansailswestcoast.com

SAILING TO SUNNIER LATITUDES

day communion services to interested cruisers.

**Equinox — Jeanneau Sun Odyssey 40
Don Whittington & Debbie Roemer
Santa Cruz**

Quote: "We're thrilled that the Baja Ha-Ha will be our first big sailing adventure!"

Debbie and Don of 'Equinox' are psyched up.



**Dilligaf — Jeanneau DS49
William Teasdale, Bellevue, WA**

Noteworthy: The word *Dilligaf* was used when things went wrong or went well aboard the submarine *Jallao*, which William served aboard.

**Kamekazi — Columbia 41
Patrick Scroggin, Anacortes, WA**

Quote: "Hand over the booze and the wenches, and nobody will get hurt."

**Black Pearl — Cal 30
Garrett Jolly, Port San Luis**

Quote: "When I bought *Black Pearl* for \$4,000, she was dirty, smelly, and what most people would consider a piece of junk. I did all the work myself to bring her back, and worked on other people's boats to save enough money for the equipment I needed. Now, although she won't win any beauty contests, she is strong, well-equipped, seaworthy, and ready for the Ha-Ha and beyond."

**Tumbleweed — Corsair F-31
Matt Daniel & Paul Boyd, Seattle, WA**

Noteworthy: They plan to trailer

Tumbleweed from Cabo to Seattle.

**C'est La Vie — Catalina 470
Keith & Susan Levy, Richmond**

Noteworthy: Keith and Susan did the Ha-Ha 10 years ago and spent most of the last decade cruising Mexico, then to the islands of the South Pacific, New Zealand, Australia, the Marshall Islands and Hawaii.

**Jubilee II — Islander 36
Barry & Joyce Ivers, Sausalito**

Noteworthy: This hull was the last Islander 36 built in Costa Mesa. It was given to the shop foreman as a gift, and he took 10 years to finish her.

**Princess Anna — Mainship 390
Michael McGuire
Channel Islands Harbor**

Quote: "We missed the '08 rally due to engine trouble, but we're rarin' to go in 2010."

**Bateau Frowe — Jeanneau DS 43
Susan French & Tom Rowe
Marina del Rey**

Noteworthy: Susan and Tom point out

Welcome to La Paz
BAJA HA-HA
Beach Party at Papas & Beer
Beach Club
THURSDAY, NOVEMBER 18TH
 mexican folk dancing
 live music by jurassic rock
 food & drinks from 4-7 pm
 door prizes and much more
 free for first fifty
 2010 baja ha-ha participants
 everyone welcome
 www.visitlapaz.org

BAJA HA-HA PROFILES, PT II

that their boat name is "almost unpronounceable in Spanish."

**La Brisa — Morgan 45
Gene Brown, San Diego**

Noteworthy: The previous owner was Michael Crawford of the *Phantom of the Opera* musical. As a result, Gene says he sometimes has an urge to start singing.

**Pacific Destination — Catalina 30
Greg Buur, King Harbor**

Quote: "Untie the docklines and let's go."

**Firefly — Catalina 470
Ted Silvas & Brenda Jewell
San Francisco**

Noteworthy: Part of Ted and Brenda's preparation for the cruising life was doing bareboat charters out of St. Martin, St. Lucia and Tahiti.

**El Tiburon — Passport 42
John Stanec & Luke Ashcroft
Emery Cove**

Noteworthy: This boat is a two-time



Meet Christine and Howard of 'Notre Reve'.

Pacific Cup finisher that was featured on the cover of the 2000 Pac Cup program.

**Notre Reve — Island Packet 40
Howard & Christine Ward
Chandler, AZ**

Quote: "This is our first rally, and also our attempt to permanently untie from the docks. We hope to continue on after the rally and see where time and tides

will take us."

**Kokomo — Sabre 425
Becky & Denny Flannigan
Tacoma, WA**

Quote: "It's a hop, skip and a jump to Cabo. So let's start resess."

**Sea Chaser — Cal 2-27
George Dorius, Coos Bay, OR**

Noteworthy: "Start small and dream big," says George. His is the smallest boat in this year's fleet.

**SEAduction — Catalina 42 MkII
Dan Lawler, Salt Lake City, UT**

Quote: "When I crewed on my first Ha-Ha, I thought of it as a once-in-a-lifetime experience. But it was so much fun, I thought, 'Why only do it once?' So I bought my own boat, and this is my third time!"

T*ime out!* That's enough introductions for one month. But you can meet the rest right here in November.

— *latitude/andy*



Combine Wind & Solar For Complete Power



Introducing The All New SB3024i/iL DUO-Option

Finally a charge controller that can serve as both a solar charging unit and wind/hydro diversion controller at the same time.

Blue Sky Energy, Inc. manufactures a wide range of solar charge controllers. Visit our website for more information.

- Shown with optional digital display
- DUO-Option supports 20 amp diversion with software upgrade
- 40 amp diversion upgrade available with high current adapter module
- Diverts excess solar power to a useful purpose

Blue Sky Energy Inc. gets rave reviews in *Practical Sailor* read the article at blueskyenergyinc.com

800-493-7877 or 760-597-1642
2598 Fortune Way, Suite K, Vista, CA 92081 USA

E-mail: sales@blueskyenergyinc.com
Web: blueskyenergyinc.com

QUALITY.....RELIABILITY.....BLUE SKY ENERGY, CHANGING THE WAY SOLAR IS USED EVERYDAY

BAJA HA-HA XVII

**A RECORD
195 BOATS
HAVE SIGNED
UP!**

**BROUGHT TO YOU BY
THESE OFFICIAL SPONSORS**

Turn the page for more →

Yachtfinders/Windseakers
in the heart of
San Diego's boating community
Specialists in cruising sailboat brokerage for 28 years
info@yachtfinders.biz • www.yachtfinders.biz
(619) 224-2349 • (866) 341-6189 toll-free
Fax (619) 224-4692

WWW.BAJA-HAHA.COM

The Rally Committee encourages you to patronize the advertisers who make this event possible – and take advantage of their Baja Ha-Ha Specials!

OPEQUIMAR
MARINE CENTER CENTRO MARINO

A Full Service Boat Yard in Puerto Vallarta
88 ton Travelift • Parts • Service • Repairs
011-52 (322) 221-1800 www.opequimar.com
info@opequimar.com

Your
Yacht Club
South of the
Border



Home
of the
Banderas Bay
Regatta

Vallarta Yacht Club

<http://vallartayachtclub.org>
<http://banderasbayregatta.com>

Everything you need from a full service yacht club.

GIVE THEM A SEND-OFF

As you may have heard, this year's entry total of 195 boats tops last year's all-time record.

If you'd like to help send this year's fleet on its way, be aware that fleet members will parade past the western tip of Shelter Island at 10 a.m., Monday, October 25, on their way out to the 11 a.m. start. A fireboat will salute them with a shower of spray, and a variety of TV and print reporters will be on hand to capture the excitement.

If you're not familiar with the event, let us explain that the Ha-Ha is a 750-mile cruisers' rally from San Diego to Cabo San Lucas, with stops along the way at Turtle Bay and Bahia Santa Maria.

You'll find frequent updates on this year's event, in addition to all sorts of other hot sailing topics at Latitude's 3-times-weekly news portal, 'Lectronic Latitude' (found at www.latitude38.com.)

Summer
is safe at
Paradise



Enjoy
your stay
with us!

Paradise Village
BEACH RESORT & SPA

011-52-322-22-66728 • www.paradisevillage.com
marina@paradisevillagegroup.com

**Nautical Books, Software, Charts
and more!**



WAYPOINT

621 - 4th St., Oakland, CA

www.waypoints.com • (510) 769-1547

**RIGGING
ONLY**

Standing and running rigging, lifelines, furlers, winches, headsail poles, main slider systems, windlasses, travelers, wire terminals, blocks and more...
Expert advice for selection and installation.

Our
26th Year! www.riggingonly.com
(508) 992-0434 • sail@riggingonly.com

ICOM

Award-winning Marine Communications Equipment

Handhelds • Mounted VHF • SSB • AIS

Visit one of our many West Coast dealers

www.icomamerica.com/marine

MONITOR
INFORMATION
auto-helm
WINDLASSES

SOS Emergency
Rudder
Say's Rig

SCANMAR Factory
Direct
INTERNATIONAL

432 South 1st Street • Pt. Richmond, CA 94804
Toll Free: (888) 946-3826 • Tel: (510) 215-2010
email: scanmar@selfsteer.com • www.selfsteer.com

West Marine

Call

1-800-BOATING

(1-800-262-8464)

for a catalog or the store nearest you.



Est. 1973

Almar Marinas

Everywhere you'd like to be
almar.com

BAJA HA-HA XVII



spinlock



The experts in rope handling and personal safety.

www.spinlockusa.com



HITCHIN' A RIDE SOUTH

Last month's Mexico-Only Crew List Party and Baja Ha-Ha Reunion on at the Encinal YC served its purpose by linking dozens of potential crew members with skippers in need of additional watch-standers.

If you missed that shindig and would really like to spend some quality time south of the border, you might still be able to find a ride by visiting our online Crew List at www.latitude38.com. It's constantly updated.

IS THE PACIFIC PUDDLE JUMP IN YOUR FUTURE?

For many cruisers, the next logical step after cruising Mexican waters for a season or more is to hang a right and head west into the Pacific.

We call that annual springtime migration the **Pacific Puddle Jump**, and report on it heavily in the pages of *Latitude 38*. Making that 3,000-mile passage is one of the most thrilling accomplishments in the realm of sailing. Learn more online at www.pacificpuddlejump.com.

VENTURA HARBOR BOATYARD

Full & Self Service Facility

(805) 654-1433

Two Travelifts • Haul Outs to 160 tons

www.vhby.com

Shoreside Work Slips • Emergency Repairs



Not just a marina – a cruiser's community
Your best destination across the Sea...

www.marina-mazatlan.com

011-52 (669) 669-2936 & 2937
elizarraga@marinamazatlan.com



Survive Your Dream

ECHO Tec Watermakers

604-925-2660

www.hydrovane.com



www.downwindmarine.com

2804 Cañon St., San Diego

(619) 224-2733 • (800) 269-0241



www.sandiegomarine.com

2636 Shelter Island Dr., San Diego

(619) 223-7159 • (800) 336-7369

Mexico 001-500-336-7369



www.sailingsupply.com

2822 Cañon Street, San Diego

(619) 225-9411 • (800) 532-3831

0D36887

Serving Boaters Since 1959

Cruise with Confidence

See Our Half-Page Ad In This Issue

(800) 992-4443

www.marinersinsurance.com

MARINERS
GENERAL INSURANCE GROUP

Newport Beach, CA • San Diego, CA
Burlingame, CA • Seattle, WA
Bradenton, FL • Puerto Vallarta, MX



Let Marina El Cid
Welcome You to Mexico

A Cruiser's Paradise!

www.elcid.com

marinaelcidmazatlan@elcid.com.mx
011-52 (669) 916-3468

¿ MEXICO BOUND ?

GERRY

SEA OF CORTEZ CHARTS

Accurate Navigation Charts & Guides

ELECTRONIC and PAPER

www.GerryCruise.com

Best Marina in Banderas Bay



MARINA RIVIERA NAYARIT
BY LA CRUISE

www.marinarivieranayarit.com

(52)3221350798

The Ultimate Boat Organization Software

Perfect for the Ha-Ha and all offshore cruising:

- Digitally organize all your boat's documents & specifications
- Store manuals, diagrams, pictures, renewals & registrations
- Keep track of maintenance items required & completed
- Save for quick access all your favorite service providers



www.BoatServiceLog.com

**SEE THE
PRE-START
BOAT PARADE
10:00 AM OCTOBER 25
SHELTER ISLAND
SAN DIEGO**

**BROUGHT TO YOU BY THESE
OFFICIAL SPONSORS**

WWW.BAJA-HAHA.COM



- Ultra Anchors • Ultra Swivels
- Quickline Flat Rope & Reel • Ultra Trip Hooks
- Ultra Chain Grabs, Ultra Snubbers & Ultra Bridles



www.Quickline.us
www.UltraAnchors.us
sales@Quickline.us
714-843-6964

The Best Marine Products from the World, for the USA.

KATADYN
MAKING WATER DRINKING WATER

Watermakers that improve the cruising lifestyle.

Watermakers that improve the cruising lifestyle.

(800) 755-6701 • www.katadyn.com
email: marine@katadyn.com

MARITIME INSTITUTE
INCORPORATED



Advanced Training for safer, more enjoyable passagemaking!

888-262-8020

www.maritimeinstitute.com

USCG Approved Classroom & Online Courses



'Solar Boost' charge controllers that combine solar/wind/hydro output for cruisers.

(800) 493-7877 www.blueskyenergyinc.com



La Paz Hotel Association

November 18: La Paz Baja Ha-Ha Beach Fiesta on the Malecón at the Papas and Beer restaurant.

011-52 (612) 122-4624
or (612) 125-6844

www.visitlapaz.org

IMPORTANT DATES

- Oct. 16 — Ha-Ha Welcome to San Diego Party, Downwind Marine, 12-4 pm. Ha-Ha entrants only.
- Oct. 23 — Informational Meeting about the Pacific Puddle Jump, West Marine, San Diego, 5 pm.
- Oct. 24, 9 am — Final deadline for all crew and skipper waivers, West Marine, San Diego.
- Oct. 24, 11 am — Skipper's meeting, West Marine, San Diego. Skippers only please.
- Oct. 24, 1 pm — Ha-Ha Halloween Costume Party and Barbecue, West Marine, San Diego.
- Oct. 25, 10 am — Fleet Parade through San Diego Harbor
- Oct. 25, 11 am — Start of Leg 1
- Oct. 30, 8 am — Start of Leg 2
- Nov. 3, 7 am — Start of Leg 3
- Nov. 5 — Cabo Beach Party
- Nov. 6 — Awards presentations hosted by the Cabo Marina.

Baja Ha-Ha, LLC
c/o 15 Locust Ave.
Mill Valley, CA 94941

WWW.BAJA-HAHA.COM

PLEASE NOTE: Correspondence relating to the event can be emailed to andy@baja-haha.com. Please don't call *Latitude 38* with questions. The Ha-Ha is a separate operation.

MARINA DE LA PAZ
FULL SERVICE MARINA
Conveniently located downtown
Tel: 011-52 (612) 122-1646
Fax: 011-52 (612) 125-5900
email: marinalapaz@prodigy.net.mx
www.marinelapaz.com

BLUE PELICAN MARINE
Nautical Consignments
A Sailor's Consignment Chandlery
Dealer for Lavac Marine Toilets
Located at Grand Marina
www.bluepelicanmarine.com
(510) 769-4858

Dedicated AIS Collision Avoidance

vespermarine
"A really amazing piece of gear. I can tell it was designed by a sailor!"
(858) 405-5810
AIS WatchMate www.vespermarine.com

THE BOAT YARD AT GRAND MARINA

"Where Service Has Meaning"

Located in Alameda **(510) 521-6100**
www.boatyardgm.com

Colligo Marine
Bringing innovative solutions to the marine industry.
Colligo Dux™ synthetic standing rigging • Emergency shroud kits
Bridle plate mooring systems • Furlers and much more.
(480) 703-3675
www.colligomarine.com

MAX EBB

"Where did all the water go?" I almost said it out loud when I saw the angle of the gangway and the mud flats around the edges of the harbor.

My having neglected to check the tide table that morning, and having been away from the marina all week, this came as a surprise. I couldn't remember ever seeing it this low. Even the normally floating dock under the boat hoist was hard aground, listing over to one side and showing more freeboard than usual.

Lee Helm had talked me into crewing for a friend of hers, a university professor who had just bought a new sport boat, presumably made possible by a lucrative consulting project. It was not the kind of boat I was used to sailing: fractional with a roller furling, one-size-fits-all jib, big bowsprit with asymmetrical masthead spinnakers, very deep keel, twin rudders, and a deck-mounted boom, just like the Open 60s. Lee had promised that I would not have to hike very hard, and the clear morning air this time of year suggested we were in for a day of easy light air sailing.

If we could ever get out of the harbor, that is. This thing had a keel draft appropriate for a boat at least twice its size.

"Lee, I think the bottom is too close to the top," I said as the hoist beam swung out over the seawall with the boat hanging from the chain. Viewed from that grounded float, it was much higher up in the air than I'm used to.

"Keel is, like, all the way up," Lee advised me as she pressed the down button.

There was not quite enough chain to lower the boat all the way down to the water, so we had to release our lifting tackle wires to get the hoist hook free of the tackle. Once free, even with the keel retracted, the bulb planted itself in the mud and the boat rolled over to one side.

"Uh, Lee, isn't this going to block the hoist till the tide comes up?" I asked

when she and the skipper joined me down on the dock next to the boat.

"I have fiendish plan," she replied, and hopped aboard. She unclipped the spinnaker halyard from the launching tube, connected a spinnaker sheet to the halyard, connected another spinnaker sheet to that one, and handed the end to me. I was now holding a line attached to the masthead that was many boatlengths long.

"Just walk over to that dock on the other side of the fairway and pull," she said.

The plan was fairly obvious. And once we had several people pulling, it seemed to work. The long halyard heeled the boat way over until the keel came free, and with the boat floating on its bilge we were able to slide it over to the guest dock where there was a little more water. But Lee was not happy with the result, for some reason.

"Solitons," she said as she pointed to the fairway that led from the dock area to more open water.

"Yes, those are nice ones. Robust structures for water waves, aren't they?" observed the professor.

It took me a while to figure out what they were looking at. It was those little waves, not much more than ripples, washing into the boat hoist area. But instead of coming in groups like normal waves, they were coming in one at a time, about 10 or 12 seconds apart. There was

not a breath of wind blowing, so the water between these little waves was dead flat.

"Notice that these waves don't have a trough," explained Lee. "Only a single moving crest, and no dispersion of energy into multiple crests and troughs as the wave advances, like the way a

deep-water wave disperses into a wave train."

"How is that possible?" I asked. "I seem to remember you trying to convince me that a wave is always losing energy to the wave behind it, and that the wave

Small dinghies with fully retractable centerboards have advantages over their less flexible sisters.



PETER LYONS / WWW.LYONSMAGING.COM

energy travels at only half the speed of the waves in a group of waves, if I have that right."

"For sure, in deep water," she replied. "Shallow water is different. You can, like, think of the wave as being slowed down by the bottom till it matches the speed of the wave energy. Then, if the shape of the wave is right, there are nonlinearities that tend to pull the wave back together, balancing the standard linear forces that would make the wave come apart."

"I guess seeing is believing," I said as I watched another solitary wave crest sweep over the shoal.

"How fast do you think they're moving?" Lee asked.

"I'd say about two knots, maximum," I guessed. "Maybe one-and-a-half."

"That means the water is about three inches deep," she informed me after hitting some buttons on her calculator watch. The waves move at the critical depth Froude number, which is the square root of gravity times depth."

"It works out that evenly?" I asked.

"Purely non-dimensional," she explained. "Gravitational acceleration is in feet per second squared. Multiply by



DUGALD DUNCAN

A modern re-enactment of the soliton (ahead of boat) in the Union Canal near Edinburgh, where the phenomenon was observed by Scott Russell in 1834.



depth and you have feet squared per second squared. Take the square root of the whole thing and you have feet per second, which is the critical speed of a shallow water wave. Speed over square root of gravity times depth is also known as the depth Froude number. And the wave resistance curves of boats totally do interesting things as they transition through this speed."

Lee produced a cellphone with a large screen that displayed a graph of water depth versus time, something I could understand.

"At least another hour until we have enough water to get out of here," she sighed. "Even with the keel all the way up."

We stowed gear on the boat, bent on the mainsail, loaded the spinnaker in the launcher, and synchronized our watches. But after every possible pre-race preparation we could think of, the water depth was still too shallow even for our retracted keel.

"Might as well wait back in the yacht club bar," I suggested, and we retreated to an inside table with a view of the launch area.

"Solitons were first identified by ship designer Scott Russell in 1834," said our professor-skipper after we had warm caffeinated drinks in hand. "He was watching some horses tow a barge down a canal near Edinburgh when the towline broke. He described a 'wave of translation' continuing out ahead of the barge, and followed it down the canal for miles on horseback. The math wasn't fully worked out till the 1960s, when the term 'soliton' was coined. Russell is

"I would argue that racing Snipes was more tactical and, in some ways, more interesting than what we do in modern boats," I countered.

better known for his hull design theories and his early demonstrations of the Doppler shift — he's the first person to put trumpet players on a railroad car."

"A soliton sounds a lot like a tidal bore, I would think," I said.

"No, tidal bores are more like shock waves, and usually involve a lot of turbulence and energy dissipation, similar to a hydraulic jump. But a soliton can exist

as a smooth wave form with almost no turbulence. Two solitons can even pass right through each other."

"Does the timing of those waves correspond to the time between the offshore swells?"

"Either that or it's, like, the natural frequency of the outer harbor," Lee surmised. "You'd have to time the waves during several different low tides to see if they correlate with variations in the offshore swell period."

The skipper looked at her watch, looked out at the harbor, and checked the start time again. "It's going to be close," she concluded, but we took comfort in the presence of several other crews waiting out the tide at nearby tables. With any luck there would be a postponement.

"Back when I started racing," I reminisced, "it was all in boats like Lightnings and Snipes. The centerboards came up flush with the bottom, the rudders kicked up or came off, and if the hull still drew too much water, to get past the mud we would all get out and push. A low tide never made us late for a start."

"But then, you were stuck sailing a Lightning or a Snipe," Lee pointed out.

"The racing was good," I countered. "And I would argue that it was more tactical and, in some ways, more interesting than what we do in modern boats.

And the great thing was that those same boats we were racing could also sail to the beach for a family picnic. Maybe that's why we usually had 20 or more for the local races, and upward of 60 at the annual regattas."

"Max remembers big," Lee remarked.

"Multi-purpose or so-called family boats are still being sold," said our skipper. "But people who want to race will naturally go for faster boats."

"Even so," I argued, "The utility of any

boat is diminished when it needs deep water to sail. Even with sportboats with retracting keels, you still need the keel crane to pull the thing up, and that's usually not part of the onboard equipment. I don't think I'd want to own any small sailboat that I couldn't sail up to a beach."

"It wouldn't be hard to design these boats with fully retractable foils," Lee

MAX EBB

suggested. "They're most of the way there already."

"It's the single-purpose, only-good-for-racing marketing," proclaimed a sailor from the next table.

"The marketing is just following consumer demand," said another crew at his table. "These are the boats that we want to sail."

"No, it's the technology," interjected a crew from the table on the other side of ours. "Carbon and epoxy make these fast boats possible."

"It's really the rating rules!" added another sailor. "The new designs are so deep these days that there are hardly any big race boats that can even use the harbor. The rule doesn't penalize deep draft like it should."

"The culture of sailing has changed," insisted someone at the first table. "And the folks who want family picnics at the beach are all buying Jet Skis."

"Everyone's forgotten," repeated the first sailor from the other table, "that the tactical game is better in heavier boats."

With about six points of unresolved



MAX EBB

Wave energy converts to solitons — crests but no troughs — across the shallow mudflat between a stranded dinghy and the shore.

contention flying between the two tables surrounding ours, we decided that the solitons were now moving a little faster and the water depth, which Lee reminded us varies by the square of the soliton speed, must have increased. We decided

to give it a try.

The keel was all the way up, everyone was hiking hard to one side, and the little outboard was churning away at full power. We finally slid over the mud into just slightly deeper water.

"Note the angle of our Kelvin wave train," Lee said as we powered out over the shallows, still heeled way over. "Normally, all the wave energy is, like, contained within a wedge having sides at 19 degrees 28 minutes to the centerline. But that's in deep water, where the group velocity is half of the phase velocity. Remember that diagram I drew a few months ago when we met for lunch on the bridge over the lagoon in the office park?"

"How could I forget?"

"If you construct the same diagram with the wave energy moving closer to wave profile speed, the angle becomes wider. I'll show you after the race."

To my great relief, Lee forgot all about her Kelvin wave train diagram. It's left as an exercise for the reader.

— max ebb

Owl Harbor MARINA

Beautiful 20 acre greenbelt park

- Up to 30' no power/inside tie @ \$4.50 per foot
- 30'- 50' berths @ \$5.50 per foot
- Home of Andreas Cove Yacht Club

Located on Seven Mile Slough, just off the San Joaquin River

1550 W. Twitchell Island Road • Isleton, CA 95641
916.777.6055 • www.owlharbor.com

OFFICIAL SPONSOR OF

Latitude 38's
Delta Doo Dah 2
July 31 - August 6

The Newest Class on the Bay

The Antrim Class 40

Congratulations to Buzz Blackett on his new Antrim Class 40, **California Condor**. The newest member of the fleet, which is already one of the most popular ocean racing classes in Europe, was built at Berkeley Marine Center.



The yard that works for you!

www.berkeleymarine.com

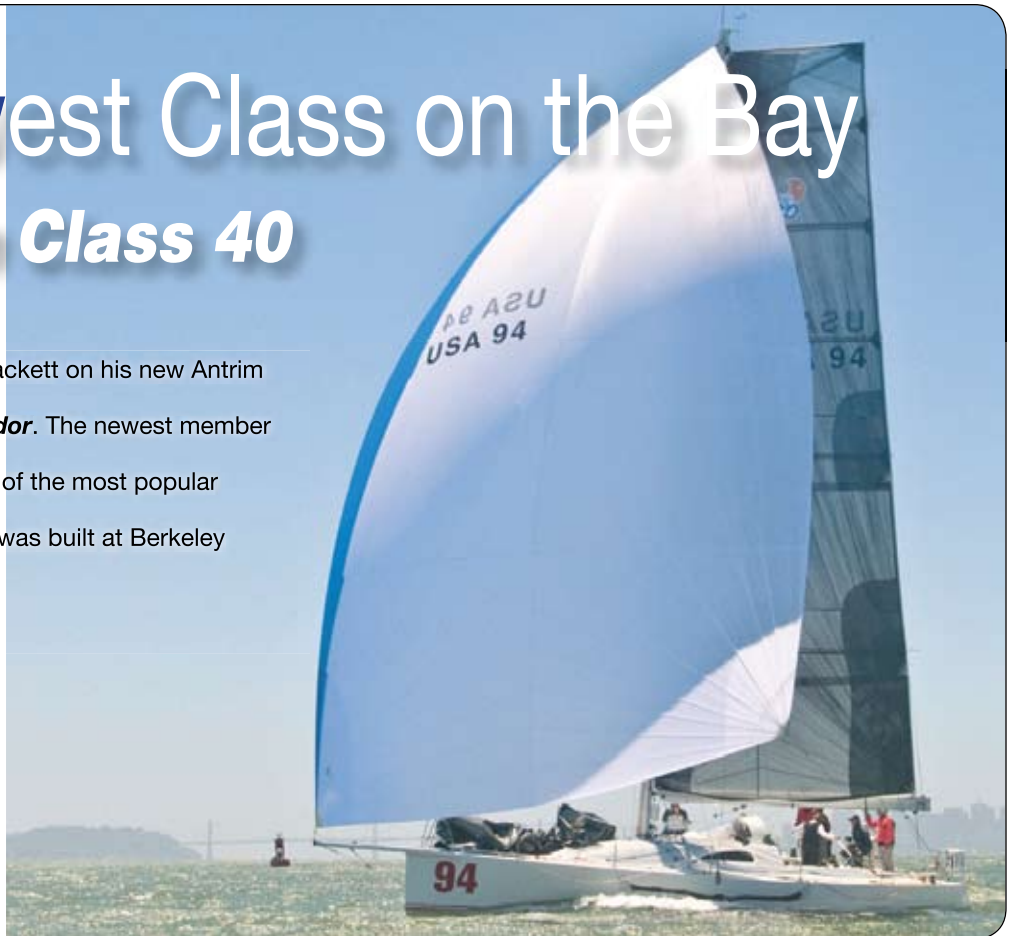

KISSINGER CANVAS

Marine Canvas & Interiors
STEVEN KISSINGER

(925) 825-6734

Covering the Entire Bay Area



- Biminis
- Boat Covers
- Cushions
- Sail Covers
- Headliners
- Awnings

DODGERS

Side handrails and window covers included.

OPTIONS

Aft handrail, dodger cover, sailing bimini.

Free Estimates and Delivery

SEASHINE

Service of the Month

MAINTENANCE

While we're at your boat we can take care of your regular maintenance needs too!

More sailing, less work.

ADDITIONAL SERVICES

Bilge Cleaning • Detailing • Maintenance Washdown • Carpet & Cushion Cleaning

Fully Insured & Marina Approved

Serving the Bay Area Since 1986

Call now for a Free Estimate

510 428-2522 or 415 457-6300

www.seashine.net

THE RACING

Wow! That was a busy month Between the **Finn Gold Cup**, some big news on the **America's Cup** front, the **Melges 32 Worlds**, the **Express 27 Nationals**, the **Windjammers Race**, **Sarcoma Cup**, **Jazz Cup**, **Richmond Riviera Regatta**, and a whole host of other things you'll find in these pages, if you weren't sailing or at least spectating, where've you been?

Finn Gold Cup

Briton Ed Wright put a wrong to right on September 4 by winning the Finn Gold Cup on the Bay. It's been an enigma of the class that the former world number one had never won a world title. He had come close on a number of occasions,



Ed Wright

but during the six day-regatta in San Francisco, he put together an incredibly consistent performance to take the Finn world title in the best possible way by dominating and winning the medal race. Spaniard

Rafa Trujillo took the Silver while another Brit, Giles Scott took the Bronze.

The final day started with race 11 for the rest of the fleet with Dutchman Pieter-Jan Postma leading round the top mark ahead of Swede Daniel Birgmark and Spaniard Alejandro Muscat. Birgmark took the lead on the first downwind and led round the remainder of the course to take his second race win of the week to finish 12th overall. Another Swede, Bjorn Allansson sailed well notching a second while third place went to Croatia's Marin Misura, securing him kept him 11th overall.

Oscar flag for free pumping downwind was raised on the first downwind leg and stayed up for the rest of the day with the

Andy Casey, Phil Ramming, Forrest Gay and coach Robbie Dean made up 'Team California'.



wind reaching 17 knots during the medal race for the top 10, which followed soon after race 11 was completed. This meant that Oscar had been raised on each and every downwind leg of the championship, giving the Jury very little to do.

The big question for the medal race was whether second placed Rafa Trujillo would go for gold or protect silver. It was obvious within minutes what his strategy would be as he stuck to third placed Giles Scott like glue and covered his wind all the way round the course. Scott was faster downwind and broke through twice but he couldn't gain enough boats to take the silver medal from the Spaniard.

Meanwhile, the regatta leader by 13 points, Ed Wright, won the pin end start and powered away, never headed during the entire race. He initially headed to the left and then crossed back to the middle without ducking a single transom. He rounded the top mark just ahead of Gasper Vincec, American Zach Railey, Thomas Le Breton, Brendan Casey, Mark Andrews, Andrew Mills, Trujillo, Ivan Kljakovic Gaspic and Scott. With Scott in last place Trujillo had done his work well.

Scott immediately went low and passed three boats leaving Trujillo at the back. With Wright sailing away from the fleet, the fight was now on for silver. Trujillo rounded the gate just behind Scott, but within a few tacks was back in control and taking Scott to the left hand side, which he thought was not favoured. Also going this way were Railey and Mills and they crossed back in second and third. Trujillo and Scott also came back into the fleet closer than Trujillo has planned and again Scott passed Trujillo downwind. But he needed to take two boats to take the silver from Trujillo.

It was a nervous last downwind for the Spaniard as Scott sailed away and he was left behind. Scott caught up the pack ahead but could not take any boats and finished ninth to take bronze, with Trujillo crossing in tenth to take the silver.

A clearly happy Wright said, "I am so excited. It's something I have been working on for a



ALL PHOTOS THIS PAGE LATITUDE/ROB EXCEPT WHERE NOTED

while. Last year I got close, but this year I did it. The last couple of days have been the best of the regatta. Really windy and really difficult sailing, but I am really so happy. I am tired, but it doesn't matter. It's over now."

Wright is renowned for being the fittest sailor in the fleet but commented, "I was surprised how fit the others guys were out there. But it does make a difference. It's nice to feel fresh each morning. I have put a lot of effort into this year did quite a lot of training over the summer and changed my body shape. Everything was gearing up towards this event. I am really happy."

"It was brutal at times. Just great sailing. The boat is a powerful boat and it's so taxing sailing here. I loved every minute of the week. Rafa has been training hard as well and was sailing fast. But it was good to actually get out there on the track and actually do some real sailing. I only had to get seventh in the final race and I managed to win it, which was even better so I am really happy with that."

"I just needed to stay near Giles and Rafa and it was apparent straight after the start that they were messing around



The Berkeley Circle delivered for the 86 Finn sailors who showed up August 29 to September 4 for the Olympic singlehander's world championship, the Gold Cup; inset Rafa Trujillo.

with each other so I could just sail my own race. I just kept a loose cover on them and it made life a lot easier. To win the last race is great. I feel like I am sailing fast and really excited going forward to the next event."

Fourth placed Railey said, "It was a good race and very intense. I went in fourth and very close with Thomas but I had a shot at third. So I wanted to try and push Giles back as much as I could, as he had to be last and I had to win the race, it was a tall order and I ended up second but he sailed very well after that."

"But I'll take fourth at a world championship, though it is disappointing not to be on the podium. That was the goal. I think I averaged a fifth and that was part of the goal coming in as we thought that would be enough for the podium, but there were three other sailors here who just sailed a little bit better than me. Ed, Rafa and Giles were the three best sailors here this week."

"It's probably the best regatta I have

sailed this year and if I can build on that this winter and work on stuff, then we'll get ready for the 2011 season.

Silver medalist Trujillo talked about his race strategy. "This morning I did my planning with my coach and we had two options. Either try to win the Gold Cup depending on the wind conditions or protect the silver. After we saw the weather conditions, we realized it would have been impossible to catch Ed and he made a fantastic start, so I tried to slow down Giles as I thought I was faster upwind though he was clearly faster downwind."

"I made a pretty good job of that and we had a nice fight with each other. I took him to the left and thought it was all over but we had more pressure and better shift and he made a fantastic job of the downwind. He was just flying and I was really worried he would catch up enough boats to take the Silver.

But congratulations to Ed and Giles and all the other Finn sailors here because I think we have had a really tough week."

"Now I have promised myself one or two months with no hiking! I think we have hiked enough in the last month. I am now 34 years old and this is my third Olympic campaign and I need to take care of myself. This kind of event is not good for me. There are a lot of juniors here at 1.95 metres and they were pushing us really hard."

www.finngoldcup.com

America's Cupdate

The match for the 34th America's Cup will be contested aboard hard-wing 72-ft catamarans in 2013. That was the main message from BMW Oracle Racing's press conference in Valencia on September 13.

While there had been plenty of what has turned out to be true speculation with regard to the AC 72 catamaran, the '13 date was a bit of a surprise, as was the announcement that the new, annual series of traveling events leading up to the Cup — dubbed the "America's Cup World Series" — would start in '11 with a one design 45-ft hard wing cat. The AC 45s will allow new teams a chance to come to grips with the new technology before building their custom AC 72s and 130-foot-tall, 2,800-sq.-foot wings for 2012. Another very pleasant surprise is that once the AC 72s come online, the AC 45s will be sailed for a "Youth America's Cup."

So what was the reasoning behind one of the most dramatic shifts in the history of the Cup?

"The America's Cup should be the best sailors in the world sailing the fastest boats on the planet," BMW Oracle

Former Bay Area guy Louis Nady got some post-race moral support from Ed Bennett; the pair were 2-1 on the 1972 US Olympic team and were some of the first to quit their jobs and train full-time.



THE RACING

ERIK SIMONSON/WWW.H2OSHOTS.COM

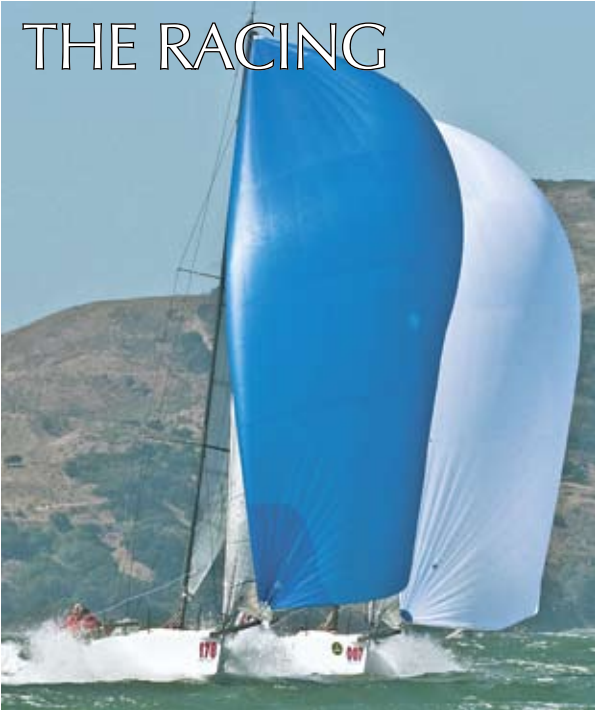

ERIK SIMONSON/WWW.H2OSHOTS.COM



ERIK SIMONSON/WWW.H2OSHOTS.COM



ELLEN HOKE/WWW.ELLENHOKE.COM



ELLEN HOKE/WWW.ELLENHOKE.COM



Clockwise from above — Blast-off! After a slow Rolex Big Boat Series, the Melges 32s got the best the Circle can bring for their World Championship September 22-25. Due to its late-breaking nature and the fact it was right after the Rolex Big Boat Series, we'll have to leave you with these photos; powering away from a weather mark; the flock takes flight; William 'Elvis' Douglass and the 'Goombay Smash' Girls; 'Bronco' gets launched; the celeb factor was high, here Russell Coutts signs autographs before a day's racing; feel small next to that sailplan? Luca Lalli (not pictured here, you can find him in the BBS feature) won.

Racing CEO Russell Coutts said in the conference call with reporters after the announcement. "If you looked at AC 32, there were a lot of sailors in their 40s and 50s; we want to bring that age range down. All of the crew are going to have super critical roles."

The new AC 72s will have a beam of 46 feet, and displace only 15,500 pounds. With a defined weight and stability, and given the fact the hulls have scantling

requirements for the outer skins, the boats should prove to be in a pretty tight ballpark.

Cup boats have to be the biggest, baddest boats out there; otherwise, there's nothing that sets them apart from the rest of the crowd. In the 12 meter era, maxi boats in the 80-ft range were the only monohulls that were larger and faster, but due to the fact that they were offshore-oriented and generally lower-tech, they

didn't effectively upstage the 12s and the Cup.

The problem with using monohulls is that of comparison: in today's world, there are canting-keeled monohulls like *Speedboat*, *ICAP leopard*, *Wild Oats XI* and the former *Alfa Romeo* that are already in the 100-ft range, and incredibly expensive to build — effectively the J Class of our era. Any smaller monohull would seem pedestrian by comparison, and anything



SHARON GREEN/WWW.ULTIMATESAILING.COM



ELLEN HOKE/WWW.ELLENHOKE.COM



larger would not only be prohibitively expensive, but severely limit the available venues due to the excessive draft required — even with a canting keel, which would in turn, require an engine — to provide the stability for a big monohull's commensurate sailplan.

Granted, *Alinghi 5* and *USA* dwarf the AC 72; but in the arena of both cost and logistics, multihulls that big are so far-fetched that it's unlikely we'll ever see anything like them again. The AC 72s will not have powered sailing systems, and will be demountable, allowing them to be packaged and shipped in 747 cargo plane,

a significantly less expensive option than the super-jumbo — and aged — Antonov cargo planes required to move around a V5 IACC boat. The AC 45s, on the other hand, go even farther in this direction: they will be able to be packed into 45-foot high-cube shipping containers. Coutts said that the performance of the AC 72s will be within a knot upwind and within a couple knots downwind of the monsters from AC 33.

Wing sails provide the most lift for the drag they produce, and unlike soft sails, don't require constant replacement. This should ultimately should see some sav-

ings for teams, which will now only build the maximum allotment of eight wing elements and buy gennakers. Multihulls lend themselves to wing sails because of the loads involved — remember that *USA's* mainsheet load went from 20 tons to 2 tons when they switched to the wing in the buildup to AC 33. The new rules will also allow the boats to be sailed with only 11 crewmembers — a significant savings in payroll for the teams, something that Coutts said represents at least 60% of their teams' budgets.

One theme to come out of our *'Lectronic Latitude* reader survey last month was

THE RACING

the lamentation that traditional match racing tactics will become less important in multihulls. To a large extent this is true, and thank God for that! By AC 32, traditional match racing tactics had come to consist of getting into the box, dialing up and drifting backwards, sails luffing for three minutes. Gone were the days of

furious circling and using spectator boats as picks. There were few tacking duels as the confidence the teams had in their weather modeling encouraged them to stay in phase and try and take advantage of any perceived straight-

line speed edge.

Multis will allow more opportunity for passing on the race course — something that was all but non-existent in AC 32 — as their speed varies so much with regard to trim. If they're not optimally sailed, speed suffers at a higher percentage of their potential for a given condition.

Coutts also said he envisions shorter weather legs so that the boats round the first mark "nose-to-tail."

"In a high-performance multihull, you have to be precise in approaching marks," he said. "In these boats a reaching course could be tactical."

If sailing is going to make the jump to a wider audience and grab the attention of non-sailors, then the intricate particulars of match racing need to be minimized. In most professional sports a simple understanding of a few basic rules is all you need to know to understand what you're watching. Sailing's rules are far too complex to teach to someone who, to start with, doesn't know what port and

Alan O' Driscoll's D-Class Catamaran 'Beowulf V' smokes into Benicia on the way to a new course record in the 25-mile Jazz Cup.

starboard are. Plus, there is no real imperative that the America's Cup should be obligated to propagate the use of a set of arbitrary (albeit widely agreed-upon) rules.

In auto racing, which is probably the closest analog to sailboat racing on the worldwide stage, there is no pre-start beyond the establishment of pole positions. There are no pre-start tactics involved; the race starts when it starts, not five minutes before. The cars go around turns and down straightaways, and these features provide context for the viewer.

Would the Bay be too small to host these monsters? Coutts said that they've calculated that the AC 72s should be capable of making three laps of the main part of the Bay in about 45 minutes.

At first blush, this might seem to further the argument that the Bay is too small for these beasts to race on. But in response to our survey, one reader posed the question, "When was the last time natural marks were used in the America's Cup?"

In fact that's one thing that Coutts touched on in the conference call, saying that it would be more visually compelling for television if a course could run past landforms. Here at *Latitude 38*, we've long since given up on trying to get photos of boats racing offshore. Why? because one rhetorical question this poses is, "does a boat racing offshore look any more exciting than a boat close to land?" The only answer we can come up with is that in general, it doesn't. To take it a step further, having the variegated Bay as a backdrop would make for even more compelling visuals.

Imagine for a second what a course that started off Treasure Island, left Alcatraz to starboard, Red Rock to Port, Angel Island to port, Yellow Bluff to port, and back down to Treasure Island would look like. There would be parking lots where the race would effectively re-start. There would be straightaways where these machines would tear up and down the Bay at mach speeds in full view of huge numbers of people.

Using all of the Bay and its micro-climates and current variations would allow opportunities for passing lanes that don't exist in most venues. Which to our minds makes the Bay a prime option. Actually, check that, the only option.



CHRISTOPHER HARVEY

JetStream in the Jazz Cup.



JIM GOSSMAN

Coutts said that the consideration of having the multiple venues in the America's Cup World Series also pointed to the AC 72, as the cats will be highly adaptable to prevailing conditions and across the 5- to 33-knot wind range prescribed by the protocol.

"They'll be completely powered up in 5 knots, and you can de-power the wing pretty effectively," Coutts said.

That would play well into sailing the boats in the Bay's highly geographically-varied conditions also, as it would put a premium on the ability to change gears quickly.

Although a '14 date for the next match would have better played into the chances that the Bay will host it, we still think there's a chance. A high-powered organizing committee including people like Peter Stoneberg, Tom Perkins, Malin Burnham, and John Sangmeister, is proceeding at full speed with efforts to get the Cup



COURTESY BEOWULF V



With the ebb, things got a little interesting at the buoy during the Jazz Cup.

here.

"The City has said unequivocally that they can be ready for a Cup match in 2013," Stoneberg said. "The City has known that it would be a possibility and have been planning for it all along — it won't change the attitude of the City.

Coutts said there were a few main considerations for having the match in '13. Chief among them was to get the event back on track as soon as possible. Second was that having a three-year cycle effectively cuts a team's budget — which he estimated at between 40 and 100 million euros — by 25%. The third was that they didn't want the Cup to be competing for exposure with the FIFA World Cup in 2014.

Since the announcement, the Golden Gate YC has announced that '87 Australian Cup skipper Iain Murray — who

incidentally was a co-drafter of the IACC rule and intended it to be a skiff-like boat — will be the regatta director, which bodes well for the event as far as we can tell.

But what about America's chances for getting the next match? That, only a handful of people really know, and we're

not them. But what we can tell you is that there are some things you can do that would help the case. First of all, if you haven't already done so, fan the Bring America's Cup 34 to San Francisco Bay Facebook page, and implore all of your Facebook friends to do the same — let's try to multiply the page's 5,000-plus fans many times over. Second, send an email of sup-

port to Mayor Gavin Newsom at gavin.newsom@sfgov.org. Finally, possibly one of the most visible and effective ways to get right to BMW Oracle Racing's top brass would be to sail this year's Leukemia Cup, where Coutts will be the keynote speaker at Saturday night's dinner.

Then cross your fingers!

Express 27 Nationals

A quality fleet of 16 Express 27s showed up at the Encinal YC September 10-12 for their national championship, and it took all seven races in the no-throut series to determine the winner.

After finishing second in Sunday's first race, Will Paxton and Zack Anderson's Richmond YC-based *Motorcycle Irene* held a one-point lead over three-time defending season champion Tom Jenkins' *Witchy Woman*. Jenkins had won that race, his fourth which set the stage for a final-race showdown between the two boats. With Brendan Busch's hull number one *Get Happy!!* just eight points behind, neither could afford to drive the other all the way back in the fleet.

When all was said and done, Paxton and Anderson won the race and the regatta. *Witchy Woman*, which had finished second, was ultimately chucked on a protest by another boat that dropped them to third and allowed *Get Happy!!* to slip into second.

"My match racing practice at the Lanes' really helped out," Paxton said of the pre-start in the last race.

"The regatta featured its customary buoy racing on Friday and Sunday on the Circle, and a distance race to Pt. Bonita on Saturday, which turned out to be a grueling affair. Starting off Treasure Island the fleet were forced to buck a four-knot flood out the Gate to Pt. Bonita, albeit in good breeze. Then, they were forced to sail in an ebb down the Estuary **Bob Harford's Express 37 'Stewball' steamrolls her way to Benicia.**



JIM GOSSMAN

THE RACING

where it got agonizingly light.

Paxton and Anderson were joined by trimmer Matt Noble, fresh off six months on the East Coast where he was working on the shore team for Alex Jackson's Juan K 100 *Speedboat*. For the first day Mini sailor Emma Creighton filled in on bow for weekend bow girl Molly Robinson. They were joined by, wait . . . there wasn't anyone else? That's right, in a class where any competitive entry sails with five sailors, *Motorcycle Irene* was sailed by only four.

"We proved it can be done," Paxton said.

The youngest sailor in the regatta was 12-year-old Miya Miller who helped John Rivlin sail his *Peaches* to fifth overall.

"Miya did a great job," Rivlin said. "All on board were amazed at her boat feel and overall great attitude."

Also getting high marks were Encinal YC regatta chair Dan Pruzan and PRO Tony Shaffer, who everyone we talked to said put on a first class event.

EXPRESS 27 NATIONALS (ENCINAL YC 9/10-12, 7r, 0t)

1) **Motorcycle Irene**, Zack Anderson/Will Paxton, 12 points; 2) **Get Happy!!**, Brendan Busch,

Sarcoma Cup founder and Sarcoma survivor Nat Criou and '10 Sarcoma Cup winner Kim Desenberg. The event grossed over \$32,000, with all of the operating costs covered by sponsorship.

23; 3) **Witchy Woman**, Tom Jenkins, 31; 4) **Wile E Coyote**, Dan Pruzan, 37; 5) **Peaches**, John Rivlin, 38. (16 boats)

Complete results at: www.encinal.org

Jazz Cup

Over one hundred boats showed up September 4 for the South Beach and Benicia YC's Jazz Cup. They were rewarded with a day that just got sunnier and breezier as it wore on.

Starting at Treasure Island in a light ebb, the reverse-start fleet was soon running hard down San Pablo Bay in breeze that reached the high teens toward the finish 25 miles away in Benicia.

Alan O' Driscoll's resurrected D-Class Catmaran *Beowulf V* took advantage of the conditions and set a new course record of just under 2 hours and 10 minutes to take elapsed-time honors, while Charlie Watt's Antrim 27 *Head Rush* corrected out as the first overall monohull. The Jazz Cup perpetual, awarded to the top finisher from either South Beach or Benicia YC went to the former and Doug Gooding's Islander 36 *Moondoggie*.

As you'd guess with a name like that, music played a big part in the after-sailing revelery, and the upper floor of the Benicia YC was jumping to what was probably one of the tightest bands we've ever heard at a regatta party. Complete results can be found at www.southbeachyc.org.

Windjammers

Bill Turpin's R/P 77 *Akela* has been on a record-setting tear lately, most recently in



LATITUDE/ROB

the Spinnaker Cup, and Turpin and co-skippers Dave Janes and Doug Baker were hoping for yet another record for their big boat in this year's 68th Windjammers Race. But it wasn't to be, with a high-pressure system making for a race so slow on September 4 that a third of the fleet dropped out somewhere along the 67-mile racetrack from the St. Francis YC to Santa Cruz YC.

Akela finished after 9h, 17m, well off the record pace, and well down the leaderboard in Division A, won by Santa Cruz local Morgan Larson aboard the Melges 32 *Warpath*. In Division B, Mark Thomas' CM 1200 *Raven* finished nearly an hour ahead of the other three finishers in Division B.

Now, you'd figure that of all the divisions, the slowest boats in Division C



LARRY PHILLIPS

THE BOX SCORES

Frankly we ran a lot short on space this month, so we have just a limited selection of results for you; we'll be wrapping up the rest of series that are coming to an end in next month's issue.

GOLDEN GATE YC FRIDAY NIGHT SERIES FINAL CUMULATIVE (9r, 2t)

SPINNAKER — 1) **Pajarito**, Ranger 23, Joe

Sheehy, 11 points; 2) **Late Harvest**, J/120, Modern Sailing, 18; 2) **Whisper**, J/105, Marc Vayn, 20. (6 boats)

NON-SPINNAKER — 1) **Mary Belle Bright**, Coronado, Bright Winn, 14; 2) **Snafu**, Canadian Sailcraft, Maurice Quillen, 17; 3) **Banana**, Cal 2-29, Wayne Carley, 18. (7 boats)

Complete results at: www.ggyc.com

BALLENA BAY YC FRIDAY NITE GRILLERS SERIES (12r, 2t)

PHRF — 1) **Tortfeasor**, Olson 34, Jeff Rude, 13 points; 2) **Dixie**, Pearson 10M, Dan Watson, 34; 2) **Legendary**, Jeanneau 41, Dave Edwards, 39. (10 boats)

Complete results at: www.bbyc.org



If you have to get dunked, the Encinal YC pool is the place to do it, not the Estuary; bottom right, from left to right, Express 27 National Champions Matt Noble, Will Paxton, Emma Creighton, Molly Robinson and Zack Anderson ask Brendan Busch: 'Hey didn't you read the sign?'

would show the highest rate of retirement, but this wasn't the case. Nine of the 11 starters finished, and when the corrected times had been calculated, David Nabors' Olson 34 *Temerity* came out on top, finishing an hour ahead of Dylan Benjamin's Dogpatch 26 *Moonshine*. Nabors and his crew of daughter Annika, Deb Fehr and Paul Harris kept the boat moving through the night and never gave up despite seeing goose eggs on the speedo at times. Nabors said that Fehr had the quote of the race.

"Deb pointed out after we had tied up

in S.C. after the race, 'You know, nobody even mentioned bagging it and motoring in,'" he said.

WINDJAMMERS RACE (SANTA CRUZ YC 9/3)

OVERALL — 1) **Warpath**, Melges 32, Morgan Larson; 2) **Raven**, CM 1200, Mark Thomas; 3) **Ocelot**, Fox 44, Kevin Flanigan; 4) **Chayah**, 1D48, Jesse Cartee; 5) **Scorpio**, Wylie 42, John Siegel. (31 boats)

PHRF A — 1) **Warpath**; 2) **Ocelot**; 3) **Chayah**. (10 boats)

PHRF B — 1) **Raven**; 2) **Scorpio**; 3) **RAM**, J/130, Robert Milligan. (10 boats)

PHRF C — 1) **Temerity**, Olson 34, David Nabors; 2) **Moonshine**, Dogpatch 26, Dylan Benjamin; 3) **Redhead**, Cal 40, Walter Smith. (11 boats)

Complete results at: www.windjammersrace.org

Sarcoma Cup

A venue change didn't hurt the third edition of the Sarcoma Cup, which drew an impressive fleet of boats to Berkeley YC August 28-29. Split between six one design and two PHRF divisions, 67 boats showed up for Saturday's buoy racing, with 84 registered for the weekend. The J/105 fleet led the charge, drawing 17 boats, followed closely by the Open 5.70s with a whopping 13 boats! Nine Express 27s, five Wabbits, five Alerion Expresses and five Viper 640s were joined by 13 PHRF boats on two courses, one on the Circle and another on Southampton. With the breeze a little lighter than the 30-plus knots seen in the Slot closer to the Gate that day, there weren't a whole lot of letter scores in the results.

Adam Spiegel's *Jam Session* took the J/105 division, while Tom Baffico's nameless, brand-new Open 5.70 carried that division — some boats had traveled from Southern California — in his first regatta in the boat since trading down in size from an Express 27. Two-time defending season champion Tom Jenkins and his crew from the Morro Bay YC on *Witchy Woman* took the Express 27 division, while Tim Russell's *Weckless* was the top Wabbit. Ralf Morgan's *Ditzzy* took

the Alerion Express 28's, while the Viper 640 honors went to Ike van Cruyningen's *Ilex*. PHRF A went to Henry King's Frers 40 One Ton *Jeannette*, while Daniel Coleman's Olson 25 *Balein* handled everyone else in PHRF B.

After the boats hit the dock and the sailing gear was hung out to dry, it was time for the après-sail. With kegs and wine providing the lubricity, those who didn't end up in an ambulatory food coma after the dinner spread put out by the club hit the dance floor for some shake 'n' bake to live music — and even a karaoke performance by a J/105 sailor who will go unnamed. There was a silent auction and chair massages for the weary, and probably more than a few bleary-eyed sailors who showed up for Sunday's pursuit race, won by Kim Desenberg's Wabbit *Mr. McGregor*. The J/105s and Alerion Expresses sailed another day of buoy racing. The event raised \$32,000 to help the significantly underfunded sarcoma research, while 100% of the event cost was covered by sponsorship. You can find complete results at www.sarcomacup.org.

Richmond Riviera Regatta

When members of the Richmond Yacht Club voted earlier this year to "Give Where You Live," and hold a charity regatta for Richmond-based charities, some said it was the first time that the club had acknowledged the serious problems in its own city. The Richmond Riviera Regatta richriv.com on August 21-22 was envisioned as being a little different from the other two huge regattas the club holds each year, the Big Daddy and the Great Pumpkin. Because of the late August date, the event was envisioned as an ideal Rolex Big Boat Series tune up regatta. So the format was three buoy races on Saturday, and a classic long Bay Tour race on Sunday.

Two course areas were used: a "deep water" course, with a Treasure Island starting area again similar to the RBBS with all the wind the Slot can deliver, plus the "Riviera" course in the vicinity

CORINTHIAN YC FRIDAY NIGHT SUMMER SERIES FINAL (8r, 0t)

NON SPINNAKER 3 — 1) **Chica**, Cal 20, Ted Goldbeck, 12 points; 2) **Roadrunner**, Ranger 23, Gregory Demetruilas, 13; 3) **Sweet Reward**, Santana 22, Craig McDow, 20. (6 boats)

NON-SPINNAKER 1 — 1) **Q**, Schumacher 40, Glenn Isaacson, 9 points; 2) **Willow**, Centurion

40s, Bob Braid, 18; 3) **Jarlen**, J/35, Robert Bloom, 22. (12 boats)

NON SPINNAKER 2 — 1) **Mimicat**, Hinckley 38, Robert Long, 8 points; 2) **Fantasea Islander**, Islander 28, Kevin Reilly, 17; 3) **Maxine**, Yankee 30, Stephen Spoja, 20. (9 boats)

J/105 — 1) **Alchemy**, Walter Sanford, 14 point; 2) **Yikes!**, Peter Stoneberg, 15; 3) **VIM**, Garry Gast, 28. (9 boats)

SPINNAKER 2 — 1) **Nothing Ventured**, Melges 24, Duane Yoslov, 20 points; 2) **Shenanigans**, Express 27, Bill Moore, 26; 3) **Tiburón**, SC 37, Steve Stroub, 26. (16 boats)

SPINNAKER 3 — 1) **Wuda Shuda**, Soverel 26 OB, Craig Page, 11 points; 2) **Big Wow!**, Rhodes 19, William Royall, 13; 3) **Spirit**, Alerion 28, Nancy Rogers, 23. (7 boats)

Complete results at: www.cyc.org

THE RACING

of Southampton, with North Bay courses, mellow winds and an easier delivery for boats with no motors. Entered boats could select their course area, and fleet splits were done from there.

Longtime RYC sailors said this may have been the first time RYC held racing on the cityfront. Conditions on that course were classic midsummer building breeze, with mild currents that made racing a battle of boatspeed and handling. Sunday's highlight was the Harding Gybe and a final weather mark rounding at Point Knox which created a "to set or not to set" dilemma in order to clear the Point Blunt buoy and go downwind to the finish line in the Berkeley Circle. On the Riviera Course there was also plenty of breeze, but the course was sheltered somewhat by Angel Island. The left became favored on the beats, but there were plenty of big shifts so it was possible to climb the ladder upwind.

The Etchells sailed as a one design



Cal Maritime will be headed to France at the end of the month for the Student Yachting World Cup.

class and along with the PHRF fleets the total was 35 boats. The parties were amazing for a new regatta. About 300 people attended "A Taste of Richmond"

on Friday night, which was the main fundraiser for the event, including a silent auction and the Freddie and the Freeloaders jazz band. Saturday night was the classic RYC party with Fast Times, a great 80s cover band (they were immediately rebooked for the Great Pumpkin — don't miss it), and Blue Lizard, a classic rock band on Sunday for the Prizegiving Party.

A long list of sponsors and donors for this regatta appears on the web page at richriv.com. The regatta raised about \$30,000 for four Richmond charities: Bay Area Rescue Mission, Richmond Emergency Food Pantry, Rubicon Programs and Youth Enrichment Strategies. These are some of the groups doing good in Richmond right now, and the members of the Richmond YC are proud to support them in this small way.

— Scott & Eva Gordon

Keelhaulers head for France

Cal Maritime will be the first West

Check Out Rob Grant's Weekend Racing Wrap-Up

(Almost)
Every Monday
on
*Electronic
Latitude*



Photo: Peter Lyons
www.lyonsimaging.com

SUBSCRIBE AT

www.latitude38.com

3/6

Join Us!

ISLANDER 36 ASSOCIATION

I-36 Nationals Regatta
Saturday, October 2, 2010
Golden Gate Yacht Club

Race for bragging rights and cool prizes! Two or more races with a starting time of 12:00.

Fall Meeting and Awards Dinner
Saturday, November 6, 2010
Oakland Yacht Club

Celebrating the 2010 Racing and Cruising Season with dinner, awards, and our famous door prize raffle.

Visit www.Islander36.org to join the Association and sign-up for our racing and cruising events.

Coast team to compete for the U.S. in the 30-year history of the Student Yachting World Cup October 23-29 in La Rochelle, France. The Keelhaulers won the right to represent the U.S. by taking college sailing's offshore championship, the Kennedy Cup, last fall.

Jessica Bernhard, Cole Davis, John Gray, Sara Himes, Sean Kelly, Sebastien Laleau, Thor Proulx, Kyle Vanderspek, Matt Van Rensselaer, and Evan Wamamaker will be trying to become the second-ever American team to win the event, which is sailed in Grand Surprise 32s.

"This is going to be a great opportunity to compete against the best student sailors in the world," said Cal Maritime's Sailing director Susan "Charlie Arms-Cartee." "But it is also going to be a huge challenge for us. Not only do we have to recover quickly from a lengthy overnight flight from San Francisco to Paris and train ride to La Rochelle, but we have to compete in a new venue with unfamiliar local weather conditions on a boat that will be new to us."

The Keelhaulers will be racing against

20 other teams from around the world, and the school is engaged in a fundraising effort to help offset the costs of the trip.

"It will cost us around \$40,000 to get them there and back, feed and house them, and pay all of our entry fees," Arms-Cartee said. "We're off to a good start, but we're reaching out to alumni, friends, supporters and the business community to help us with contributions big and small."

The team also has opportunities for larger donors to place sponsorship logos on the hull and sails during the competi-



YVANN ZEDDA

Michel Desjoyeaux's brand new 'Foncia' will be headed away from France in the route du Rhum come November. Note the double chines.

tion. They've set up a special TeamUSA blog, linked to the Academy's homepage at www.csum.edu or directly at <http://followteamusa.csum.edu>. There are detailed reports, photos and videos about



Help Cal Maritime's Sailors Compete on the International Stage

Last year, the cadet sailors of The California Maritime Academy, Vallejo, CA, captured the National Collegiate Offshore Sailing Championship and designation as Team USA in the annual Student Yachting World Cup in La Rochelle, France October 23-29.

They will be competing against some of the world's top college teams. They are the first West Coast team to enter in the 30-year history of the Cup and could become only the second American team ever to take the top prize.

Your tax-deductible contribution of any size will help assure our ability to compete. Make payments to:
The California Maritime Academy Foundation
World Cup Fund
 200 Maritime Academy Drive
 Vallejo, CA 94590

See The Racing Sheet here for more details. Visit www.csum.edu for reports, photos and videos as the team prepares for and competes in the week-long Cup competition.



THE RACING

their preparations, and this will be the primary outlet for updates during the event. Contributions can be made c/o The California Maritime Academy Foundation, 200 Maritime Academy Drive, Vallejo, CA 94590, and flagged for the World Cup Team Fund or online via the TeamUSA site. If you're interested in getting a sponsor logo on the boat during the regatta, contact Jennifer Whitty at (707) 654-1246 to find out more about that.

A Cat North Americans

Seven West Coast sailors made the trek to the southwest shores of Lake Erie and the North Cape YC in LaSalle Michigan September 14-17 for the A Class Catamaran North Americans. A strong fleet of 43 boats including the likes of Randy Smyth, Matt Struble and five-time defending champion Lars Guck was almost complete — the only person missing was former world champ Pete Melvin, who had to skip the regatta to unveil the AC 72s in Valencia with BMW Oracle Racing.

With breeze that ranged from 5 to 25 knots the venue threw just about every challenge in the book at the fleet and the



Santa Cruz's Paul Allen on his way to a fifth at the A-Cat North Americans in Michigan last month.

West Coast sailors proved they were up to the task. San Diego's Struble finished three points clear of Rhode Islander Guck to win the regatta. Long Beach's Craig Yandow ended up in fourth, right behind

Floridian Smyth, and Santa Cruz's Paul Allen rounded out the top-five.

Prince of Wales

St. Francis YC's Shawn Bennett and his team of Adam Roberts, Tom Purdy, and Melissa Purdy Feagin beat some of the country's best match racers to win the Prince of Wales Bowl for the U.S. Match Racing Championship on September 19.

Carrying over the momentum gained from defeating three-time champion Dave Perry in the semifinals the day before, Bennett upended number one seed Taylor Canfield in the finals by winning three straight races for his first Prince of Wales Bowl title. Bennett's team was a perfect 5-0 in the semifinal and finals combined and won the last seven races of their championship to finish the event with an 11-3 record overall. Two of their three losses came to Canfield and Perry in the round robin stage. Hosted by the Bayview YC in Detroit, the regatta was sailed in Ultimate 20s.

"It's a surprise more than anything," said Bennett. "I think the conditions came together for us. I've sailed a lot on Melges



**CELEBRATING OUR
26th YEAR OF SERVICE**

SAN FRANCISCO BOAT WORKS

835 Terry A. François St., San Francisco, CA 94158
(415) 626-3275 Fax (415) 626-9172

www.sfboatworks.com info@sfboatworks.net

Be our guest for lunch at the historic Ramp Restaurant*

*Some restrictions apply



for Savings!

**TIME MARCHES ON...
But boating weather
is still perfect in
the Bay Area!**

**Mention this ad for a
"Fall Is Back"
Discount**



24s, which are similar. The crew did a great job on calling the puffs. Taylor is a great starter but we were able to sneak by him."

Bennett was quick to compliment his crew after the win. "Tom Purdy was on bow and did an excellent job getting the sails up and down. Adam Roberts was trimming. He's a 470 sailor and did a great job too. Melissa Purdy Feagin connected the puffs for us and I think that made a huge difference."

By virtue of his win, Bennett qualified to represent the U.S. in the 2011 ISAF Nations Cup. He'll also receive an invitation to race in the 2011 Knickerbocker Cup and 2011 Ficker Cup, Grade 2 events and World Tour qualifiers.

Le Prof on the Prowl

On 20th September 2010 at 1533 hours, FONCIA, Michel Desjoyeaux' new 60 foot Imoca 60, was launched in Port-La-Forêt.

This latest VPLP/Verdier design, whose design was completed back in January, has been built and assembled in record time (6 months). Desjoyeaux and

his team now have 40 days to get the feel for the boat prior to the start of the Route du Rhum on 31st October 2010.

"Someone once said that the stage after 'demanding' was 'a real drag,'" Desjoyeaux said. "Well, I think I'm still at the upper stage! I've been involved in the whole thing, from the design through to tightening bolts in the yard. Of my 4 boats, I reckon I'll know this one best. To know the boat inside out has always been my leitmotif: the more you know about how



AMORY ROSS

From left, Shawn Bennett, Adam Roberts, Melissa Purdy Feagin, and Tom Purdy are the new Prince of Wales Bowl champions and head for a Grade 2 match racing event.

it's made, the better you can use it, even more so when the discovery period in the marine environment is short".



Bluerush Boardsports

STAND UP PADDLE CENTER NOW OPEN IN SAUSALITO

Full Service Sales & Rentals

Featuring **SLAM** Sportswear

C4 Bark Infinity Pearson Starboard
Jimmy Lewis NSP SurfTech Laird
Paddle Surf Hawaii Everpaddle Quickblade
Werner Kialoa Kaenon Da Kine

CLIPPER YACHT HARBOR
400 Harbor Drive, Suite A
www.bluerushboardsports.com
(415) 339-9112



WORLD

With a special report this month on **The Prime Sailing Venues of the Lesser Antilles.**

Eastern Caribbean Chartering: A Multinational Patchwork of Islands

Here in the Bay Area we've had the dreariest summer in recent memory — *w-a-a-y* too many cold, gray days, and far too few splendidly sunny ones. No wonder we find ourselves jonesing for a sunny tropical sailing vacation. And we'd be willing to bet you feel the same.

So this month we'll take a look at some enticing possibilities for warm winter getaways in the sun-kissed isles of the Eastern Caribbean.

First, a little background. As every sailor worth his salt knows, the 500-mile chain of islands between the Virgin Islands and Grenada comprises one of the most idyllic cruising grounds on earth. With the promise of easterly trade winds blowing practically every day of the year, hundreds of well-protected anchorages, ample shoreside infrastructure, and perennially sunny skies, it's no surprise that more yacht chartering is done within this island chain — which cartographers call the Lesser Antilles — than anywhere else on Earth.

Beyond the region's physical characteristics though, much of its allure, when compared to other prime charter venues, is its multiculturalism. As every grade-school scholar should know, in the 1600s and 1700s, during the Colonial Era, European nations battled ferociously for control of these island

Down in the British Virgins, where sailing is definitely a way of life, you'll find boats of all descriptions.

gems. When the smoke finally cleared in the late 1700s England, France, Spain, Holland, Denmark and Sweden had all planted their flags in the turf of one island or another. And while most of these isles have now become independent countries, they all still maintain strong cultural links to their ancestral mother nations. As a result, traveling among them is an ever-changing cultural feast.

As cruising sailors quickly learn after arrival here, there are so many worthwhile places to explore, you could literally spend years sailing the Antilles chain and still not see them all. So the first task for prospective charterers with only a week or two to spare is to choose a portion of the group to sail in. For our purposes here, we'll break down the choices as follows: The Virgin Islands, the Northern Leewards, Antigua and Barbuda, the Middle Antilles, and the Grenadines and Grenada.

Before we discuss the distinguishing characteristics of each venue, though, we should point out that you can find well-maintained, late-model bareboats — both monohulls and catamarans — in each of these areas. (In the largest chartering markets, such as the BVI and St. Maarten, 'second tier' companies also offer slightly older boats at discounted prices.)

The Eastern Caribbean is also home to many of the world's finest crewed charter yachts. So if you're feeling flush, or have a special reason to splurge, you

can choose from an eye-popping selection of luxury yachts, whose professional crews will spoil you with round-the-clock service. Most crewed yachts are based at either Antigua, St. Maarten or the British Virgin Islands, but by special arrangement many will pick up and drop off passengers just about anywhere along the

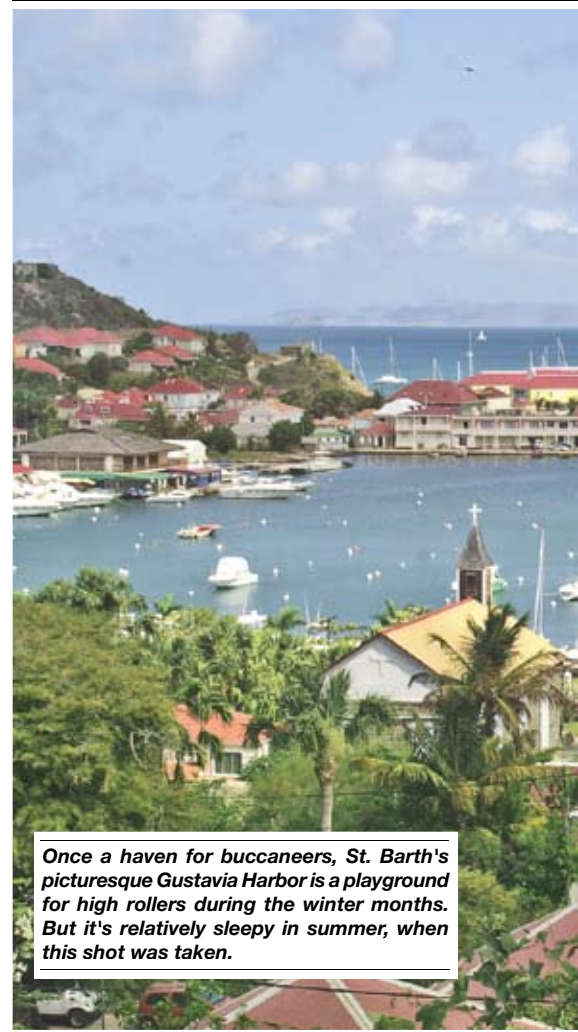

Once a haven for buccaneers, St. Barth's picturesque Gustavia Harbor is a playground for high rollers during the winter months. But it's relatively sleepy in summer, when this shot was taken.

island chain.

Only a few islands can boast non-stop flights from major U.S. gateways, but every island with a bareboat base is well served by short-hop flights from the major Caribbean hubs: Puerto Rico, St. Maarten and Barbados. While several Caribbean airlines offer island-hopper flights, American Airlines is the dominant force in the region, offering integration of both international and local flights — which means you can save yourself some hassle by checking your bags all the way from SFO, LAX or SEA to, say, Antigua, Guadeloupe or Grenada.

Another flight note concerns frequent flyer miles. We always suggest using your miles for travel to the Caribbean, as you tend to get a much better deal than when flying to other destinations. American charges you only 25,000 to 35,000 miles for a round trip to your final Caribbean destination, while a typical economy-class ticket might cost \$650 to \$1,000. By contrast, for an 'award ticket' to Europe you'll have to shell out nearly double that amount of miles, despite the



LATITUDE / ANDY

OF CHARTERING

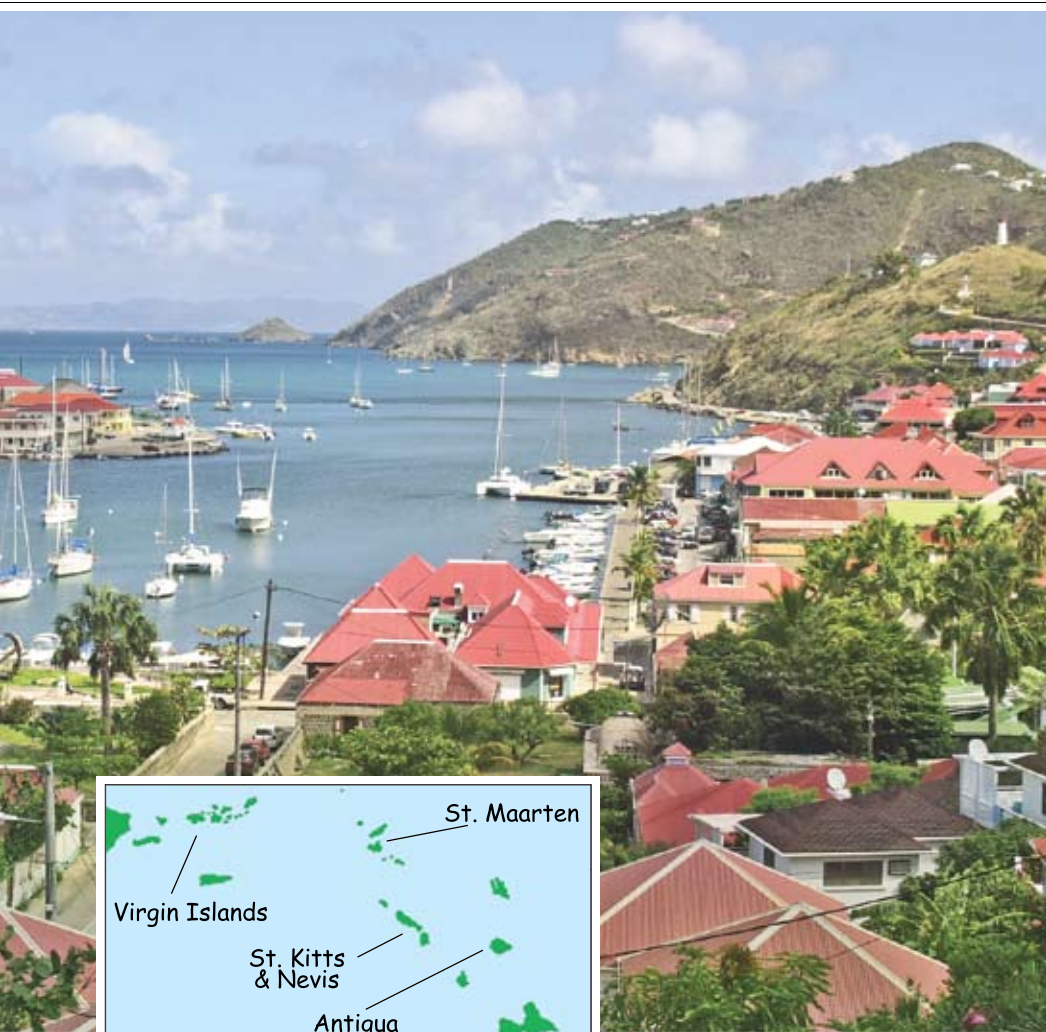

LATITUDE / ANDY

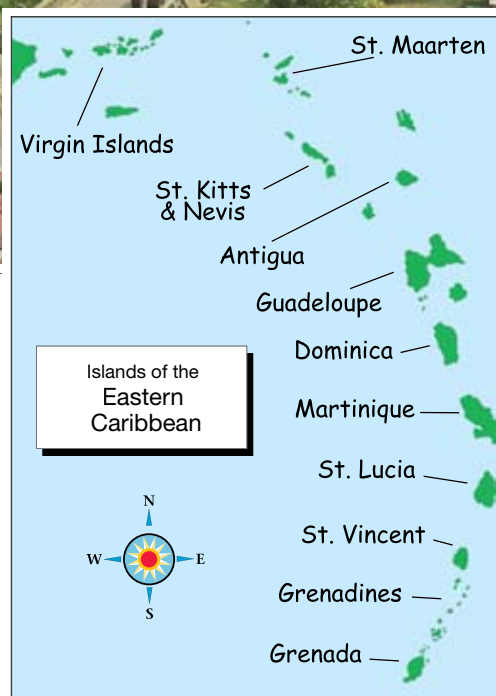

fact that there are many bargain flights to 'the Continent'. If you have miles on United or other carriers with limited Caribbean penetration, consider using them to get to Puerto Rico, then pay for an island-hopper from there to your final destination.

Most basic travelers' concerns are relatively painless in these islands. While Euros are used in the French islands and Eastern Caribbean (EC) dollars are used in most English-speaking islands, good

old American greenbacks are accepted almost everywhere, as are debit and credit cards. Be warned, however, that while ATMs are found in all airports and major towns, smaller and more remote islands may not have them.

Similarly, a wide variety of fresh provisions can be found on all large islands, while supplies at smaller isles will be limited. That said, every bareboat company in the region offers provisioning packages, designed to save you time and hassle. The goods you order in advance will typically be placed aboard your boat prior to your arrival.

If you're like us, part of the attraction of a sailing cruise in foreign waters is getting away from phones, faxes, TV and email. However, if you do need to

stay in touch, there's pretty good cell reception these days throughout the islands. But we suggest you become crystal clear on the roaming charges before leaving home. WiFi connections are becoming more prevalent every year, but you'll rarely find the level of bandwidth that you're used to at home.

Naturally, French is the official language of all the French islands, but with economies that depend on tourism, most shopkeepers, restaurateurs and service personnel speak at least some English also. On the Dutch islands, virtually everyone speaks English. And, of course, in all the formerly British isles English is the official language, although it might take you a while to get used to the subtleties of the distinctly Caribbean *patois* spoken by islanders.

As you peruse the following snapshots of key Caribbean sailing grounds, you may find it hard to choose just one section to sail in. If so, we suggest you consider doing a one-directional charter. Although you'll usually have to pay extra for the boat to be delivered back to its home base, such itineraries allow you to maximize the number of places you visit, while eliminating back-tracking — and, if you plan it right, minimizing windward sailing. Guadeloupe to the British Virgins in 10 or 12 days is a good example. We've done that trip twice ourselves. Whatever your game plan, though, we'd strongly discourage you from planning an itinerary so ambitious that you find yourself rushing from point A to point B. After all, one of your goals should be to relax and slow way down to the blissfully laid-back

One of the joys of making landfall in the French Islands is the availability of genuine French pastries and piping-hot baguettes.



KENT BENEDICT

WORLD

pace of Caribbean living.

With that, let's look at the factors that distinguish one potential chartering venue from another.

The Virgin Islands — By far, more chartering takes place in the U.S. and British Virgin Islands than anywhere else in the Caribbean or the wider world. And the British half of the archipelago gets the lion's share of it. As you've undoubtedly read time and again, the BVI is the hands-down favorite choice for first-time charterers due to its well-protected waters, traveler-friendly infrastructure and the close proximity of its many islands. You can easily stop at one island for lunch and another for dinner with a snorkeling stop or two in between.

We've lived in these islands and done the 'BVI milk run' dozens of times, but we still never tire of sailing these waters. We'd be remiss, however, if we didn't point out that during the peak winter season the most popular anchorages can get pretty crowded — although the recession has substantially diminished this problem.



LATITUDE / ANDY

In the British Virgins, "limin'" is a favorite pastime. That is, chillin' out and relaxing at a decidedly laid-back pace.

Because water-borne tourism is the biggest 'cash crop' here, the government took unprecedented steps long ago to insure the longevity of its touristic ap-

peal. For example, the waters of the entire country are now a marine preserve, virtually all popular anchorages are peppered with well-maintained overnight moorings, and there are no high-rise buildings in the entire country.

Thanks to the availability of moorings, the aspect of chartering that's usually the most stressful for neophytes — anchoring — is virtually eliminated, and the coral on the sea floor now gets much less damage than previously. Because charter operations here are larger than almost anywhere else, fix-it boats can normally make a 'house call' to your boat in any anchorage within hours of a breakdown.

The must-see stops here are practically household names in the world of sailing: the boulder-strewn grottoes called The Baths and the world-renowned Bitter End Yacht Club (both on Virgin Gorda); the famous barefoot party bar on Jost Van Dyke called Foxy's; the idyllic, palm-lined crescent called Cane Garden Bay on Tortola; and the Norman Island treasure caves, where, according to a

"We had a true, worry-free 14 days of sailing. We got everything we asked for and then some!"
A satisfied BVI Yacht Charters Guest

Join us at the Annapolis Boat Show 2010. Booth D42!



Call: +1 888 615 4006
Or: +1 284 494 4289

BVI Yacht Charters is the first port of call for all yacht charters in the BVI. Whether you are looking for Bareboat or Crewed yachts, a Catamaran or a Monohull, a week or just a few days, our professional team is on hand to make it work, your way.

BVI YACHT CHARTERS
www.bviyc.com
charters@bviyc.com

Sail Mexico Aboard the Schooner Seaward ~ Winter 2011

Answer the 'Call of the Sea' Adventure Voyages to Mexico's Sea of Cortez

Contact us now! Limited Availability!

Be part of the adventure. This is a hands-on opportunity for all levels of sailors to enjoy the pristine beauty of Baja and camaraderie with your shipmates.

Log Angeles to Cabo San Lucas	January 7-19
La Paz to La Paz	January 25-30
La Paz to Cabo San Lucas	February 28-March 5
Cabo San Lucas to Los Angeles	March 8-22
Los Angeles to San Francisco	March 24-29

These trips share the educational spirit of Call of the Sea's mission and help support our Youth Programs. *Seaward* is an 82-ft USCG-inspected vessel owned by Call of the Sea, a non-profit educational organization.

www.CalloftheSea.org • (415) 331-3214 • info@callofthesea.org

OF CHARTERING

highly questionable legend, buccaneers once stashed their ill-gotten booty. After a week of sailing here, most first-timers will have built up enough confidence to sample more challenging sailing 'down island' — as the locals say.

The Northern Leewards — The 90-mile Anegada passage separates the BVI from the northern end of the Leeward Antilles, where the half-French, half-Dutch island of St. Martin/St. Maarten is the principal charter base. From here, you could sail all the way to Grenada by line-of-sight navigation. That is, your next target would never be beyond your range of vision. So, needless to say, inter-island sailing distances are relatively short and navigation is relatively easy throughout the chain.

If you like cultural diversity, chartering out of St. Maarten should be high on your wish list. This sophisticated French/Dutch island offers duty-free shopping, casino gambling, many fine restaurants and at least one world-famous nude beach. But only a day's

sail away, at either the Dutch islands of Saba or St. Eustatius, or the formerly British islands of St. Kitts and Nevis, you'll think you've stepped back in time due to their minimal development and 'old Caribbean' flavor. Mix in a visit to the chic French island of St. Barth — favorite isle of rock stars, royalty and tabloid celebs — and you've got a charter itinerary that offers something for everyone.

Some of the region's highlights are world-class diving at Saba, climbing the battlements of the historic Brimstone Hill fortress on St. Kitts, visiting Nevis' thoughtfully refurbished plantation-



DEBBIE COLLIER

On Barbuda, Codrington is the only real town. And this friendly watering hole is the most popular place for a cool brew.

hotels, and clubbin' in St. Maarten.

The lay of the land is such that you can do a highly-varied tour in a week, and the inter-island passages are often lively.

Real People. Real Sailing. Real Fun.



Sail Cats | Power Cats
Monohulls | Trawlers
Bareboat | Skipped

Real Choices.

Choose CYOA and become part of the family. We've been providing beautifully maintained yachts, personal service and sensible prices to sailors since 1980.



1-800-944-2962
info@cyoacharters.com
www.cyoacharters.com
St. Thomas USVI 00802

CYOA
YACHT CHARTERS



Tortola BVI
Belize
The Grenadines

UNIQUELY
TMM



Marisa
TMM Belize

Most charter companies offer blue water & palm trees, but it takes the personalized care of people like Marisa to make your vacation a success.

Like Marisa, everyone at TMM is committed to your complete satisfaction. Our specialized three-location operation offers large company quality with small company service. A combination that is uniquely TMM.

TMM
Yacht Charters
Since 1979

catamarans • monohulls
motor yachts
ownership programs

WORLD

Antigua and Barbuda — In the world of sailing, the two-island nation of Antigua and Barbuda is best known for its annual springtime Sailing Week — the Caribbean's biggest and most prestigious regatta — which draws entries from up and down the island chain, as well as from Europe and North America. But racers often miss some of the island's more unique attractions, such as exploring colonial-era hilltop battlements and the refurbished buildings of Nelson's Dockyard, where England's West Indies Squadron once serviced its warships.

Tourism folks like to say Antigua has a beach for every day of the year. We're not so sure about that arithmetic, but we'll concede that there are *plenty* of them, in addition to a wealth of secluded anchorages within the reefs and islets of its northeast side.

But the thing that literally every racer — and most charterers — miss here is the sister island of Barbuda. With only a tiny population, a couple of small hotels and minimal infrastructure, this oblong, reef-fringed island is truly a 'sleeper' among Caribbean destinations. We think



LATITUDE / ANDY

Light air? No worries. One of the goals of every Caribbean charter should be to chill out, slow down and find your 'inner beachbum'.

the tranquility of its endless white-sand beaches and the promise of excellent snorkeling on unspoiled reefs make it

well worth the 50-mile round-trip sail from Antigua's north coast.

The Middle Antilles — For lack of a better name, we'll refer to the large French islands of Guadeloupe and Martinique, plus the formerly British isle of Dominica — which is sandwiched between them — as the Middle Antilles.

Both Guadeloupe and Martinique offer a mix of big city sophistication and the funky charm of waterside fishing villages. Relatively few Americans focus their travels on either island, or on Dominica, which is one of the least-developed islands in the entire Caribbean. But to our way of thinking that makes them all the more appealing. Unlike their drier northern cousins, these large islands have lush rainforests, rivers, waterfalls, and plenty of home-grown agriculture. Because both Guadeloupe and Martinique are departments of France (like our states), their citizens enjoy full rights as French citizens, trips to Paris are considered to be "domestic flights," and the supermarkets carry a wide range of

**Income? Moorage?
Tax Saving?**
Ask Bellhaven about the advantages of charter boat ownership.

Bellhaven Yacht Sales & Charters

- San Juans
- Gulf Islands
- Desolation Sound

Power & Sail Charters
ASA Sailing & Power School

www.bellhaven.net
bellhaven@bellhaven.net
877-310-9471

BELLINGHAM, WA

VALLEJO MARINA

Boat U.S. COOPERATING MARINA

Gateway to the Bay & Delta

Ask us about our FALL SPECIALS on guest docking

- Competitive Rates!
- Ample Guest Dock
- Full Service Boat Yard and Chandlery
- 2 Restaurants for Breakfast, Lunch, Cocktails and Dinner
- Covered and Open Berths

(707) 648-4370 • Fax (707) 648-4660
42 Harbor Way • Vallejo, CA 94590
www.ci.vallejo.ca.us marina@ci.vallejo.ca.us

How to Read Latitude 38 in the Azores:

Download our eBooks **FREE!**

www.latitude38.com

OF CHARTERING

French delicacies. Needless to say, you can find fine French cuisine in the cities, plus authentically flaky — in the best sense of the word — pastries.

In this central stretch of the Antilles, inter-island passages tend to be substantially more challenging than in the Virgins or down-island in the closely-clustered Grenadines. Neophytes might consider that fact to be daunting, but more experienced sailors tend to define 20 to 25 knots on the beam as big fun. While sailing in the lee of these tall, mountainous islands you'll often find relatively gentle land breezes and flat water.

Among our favorite spots here are Martinique's St. Pierre, whose one-time sophistication earned it the moniker 'Paris of the Caribbean' before nearby Mt. Pelée erupted violently in 1902, wiping out all but two survivors: a cobbler who was at work in his cellar and a murderer, condemned to an isolated cell. Despite that grim history, the town has been fastidiously restored, and its museum is well worth a look.

On Dominica, a must-see for every sailor is a guided small boat ride up the heavily jungled Indian River, near the town of Portsmouth. And if you like to hike, don't miss the chance to explore the island's primeval rainforest via well-established trails.

When visiting Guadeloupe, our favorite stopovers are at near-shore Pigeon Island, which boasts some of the best snorkeling and diving in the Caribbean in its Cousteau National Park, and the idyllic cluster of islands called Les Saintes, where life is slow and sweet.

The Grenadines and Grenada — Most St. Lucians probably wouldn't be pleased with us for lumping their island in with its southern neighbors. But we'll do so



LATITUDE / ANDY

A family sailing vacation in the Eastern Caribbean is sure to yield lasting memories — and your kids will never be bored.

here because many Grenadine charters begin at the long-established charter bases of St. Lucia's Marigot Bay and Rodney Bay.

Another tall, lush island with prolific

Custom Canvas & Interiors



The Gianola Family has been designing and fabricating custom canvas and interiors since 1969. Gianola Canvas Products offers you the best in quality, more choices, and personal service.



265-B Gate 5 Road
Sausalito, CA 94965
(415) 332-3339
www.gianolacanvas.com



A wild downwind ride.

A new 20-foot club racer with carbon-fiber keel, spars, bowsprit and rudder. Lightweight and trailerable.

LOA	LWL	Beam	Draft	Displ.	Spar
19' 6"	18' 0"	5' 11"	4' 6"	835	Carbon

Ready to Race for \$24K

landingschoolboats.com

207-985-7976

WORLD OF CHARTERING

agriculture, St. Lucia's most famous attractions for sailors are the twin tooth-like peaks called the Pitons. Most sailors simply marvel at their verdant beauty from the comfort of their cockpits while anchored at nearby Soufriere Bay. But if you're fit and full of energy, a hike to the top of either pinnacle will give you a spectacular panoramic view.

The large, agricultural island of St. Vincent defines the northern end of the Grenadines. While lush and beautiful, its main attraction for sailors is its charter bases, located in the far south. The Grenadines themselves are a cluster of small islands and cays, renowned for easy sailing in protected waters, with short hops between anchorages.

Like the Virgin Islands to the north, the entire cluster of Grenadine islands, from Bequia in the north to Grenada in the south, are part of one broad archipelago, but somewhere along the line it got chopped in half. As a result, the relatively large island of Carriacou — where islanders still build hand-hewn sloops on the beach — is aligned with Grenada. Regardless of which end you start at,



LATITUDE / ANDY

The Eastern Caribbean is full of curious things, such as this rocky pinnacle near Antigua, which is officially named the Kingdom of Redonda.

it's easy to clear into and out of either country. And given enough time — 10 days or more — it would be wonderful to explore this entire string of gems in one direction or the other.

For us, the highlights here are kicking back in the tranquil anchorages and

friendly beach bars of Bequia, snorkeling on the massive reefs of the Tobago Cays, seeing if we can catch a glimpse of an international celeb at the uniquely upscale island of Mustique, and watching the shipwrights practice their ancient artistry on Carriacou.

Grenada itself is a charming island with one of the most beautiful harbors — St. George's — we've ever seen. If you begin or end your charter there, be sure to take a taxi tour of the island's rich interior and you'll soon know why it's long been known as the 'spice island'.

This once-over-lightly overview of the Lesser Antilles doesn't even begin to describe all that these islands have to offer. But hopefully we've given you enough food for thought to inspire you to expand your research.

There's no doubt about it, winter is on its way. To ease the pain, our advice is to shanghai a crew of spirited sailors and lock in a booking for a winter getaway in the Antilles. We think you'll find that it's the perfect antidote for the gray sky blues.

— latitude/andy

WINDEX INNOVATION

WINDEX 15
Now with **Bird-Proof Spike!**



Why Windex 15 is the choice for most sailors:

- 15" wind vane (38 cm)
- Sapphire suspension bearing
- Adjustable tacking arms with tabs
- Vane and tabs feature reflectors for high visibility day and night
- Weighs just 3.9 ounces (111 grams)
- Stands 12.75" tall (32 cm)
- Bird-proof spike extends another 10" (24 cm) above vane to discourage birds from landing.

The versatile J-Base can be purchased for Windex 15 to allow top or side mounting.



Contact us for your FREE copy of the latest **DAVIS** catalog.

Davis Instruments 3465 Diablo Ave., Hayward, CA 94545 U.S.A.
Phone 800-678-3669 • Fax 510-670-0589 • E-Mail info@davisnet.com
www.davisnet.com

Advanced LED Navigation Lighting

See us at the Annapolis Boat Show at the North East Rigging Systems booth #L6-8



Super Bright
Waterproof
Multiple Color Configurations
Excellent Viewing Angles
Lifetime Warranty

Available at: **SVENDSEN'S MARINE**

Call or visit our website to learn more about our quality lighting products.

www.LunaseaLighting.com
1.800.272.0170

RoHS compliant **FC CE**

LUNASEA LIGHTING

LOCH LOMOND MARINA

**Slips Available:
53-ft, 46-ft
and 40-ft**

**Completely Rebuilt Marina • Gas & Diesel Fuel Dock • Free Pump Out Station
Modern Launch Ramp • Guest Slips Available • Marine Mechanical Boat Repair
Arena Marine Supply Store • Andy's Local Market • Bait Shop
Land or Sea Canvas • Windjammer Yacht Sales • Loch Lomond Yacht Club**

110 Loch Lomond Drive, San Rafael, CA 94901

Phone: (415) 454-7228 • Fax: (415) 454-6154

www.lochlomondmarina.com

Harbor Master – Pat Lopez • pat@lochlomondmarina.com



Bilge Steam Cleaning Oil Changes

Professional service at your slip!!!

MarineLube 877 744-2244
www.MarineLube.biz



Fuel Polishing

Tank Cleaning

QUALITY CUSTOM CRUISING SAILS FOR LESS!

LEE SAILS

**NOW
10%
OFF**

**MAINSAILS
MIZZENS
STAYSAILS
HEADSAILS
SPINNAKERS
SAILCOVERS
STRONGTRACK**

(510) 290-0955 • leesailsnc@yahoo.com

2021 Alaska Packer Pl. • Grand Marina • Alameda, CA 94501

SAILMAKER TO THE WORLD SINCE 1947

DF DIESEL FUEL FILTERING



Purify Diesel Fuel & Flush Tanks

Process scrubs, polishes, removes algae, dirt, sludge, rust, water, and foreign particles from diesel fuel. Includes internal tank washdown. Save your injectors, costly engine repair and down time.

Since 1989. Fully insured. Your berth or boat yard.

(510) 521-6797 Fax: (510) 521-3309

www.dieselfuelfilterings.com



MARINE BATTERIES

LIFELINE
...the heart of your system®

Available at the following local marine chandleries and service distributors:



ALAMEDA

- Alameda Prop & Machine
- Fortman Marina Store
- The Boatyard at Grand Marina
- Star Marine
- Svendsen's Chandlery

BENICIA

- Cruising Seas Services

MARTINEZ

- Diablo Marine

OAKLAND

- Golden State Diesel
- Outboard Motor Shop

OAKLEY

- Big Break Marina

RICHMOND

- Swedish Marine

- Bay Marine

SAUSALITO

- Sausalito Marine

AMERICAN BATTERY • Hayward, CA • (510) 259-1150

CHANGES

With reports this month from **Cocokai** on the death of Ducky in the Solomon Islands; from **Geja** in Albania and Greece; from **X** in Malaysia; from **Niki Wiki** on satisfactory but inexpensive surgery in Guatemala; from **Sea Level** in Fiji on the flipping of the cat Anna; and **Cruise Notes**.

Cocokai — 65-ft Schooner Jennifer & Coco Sanders, Greg King The Death of Ducky the Dog (Long Beach)

It's with great sadness that I have to report the passing of our lab Ducky, the best dog ever! In the last month or so she had been weakening, but we were hopeful, as she seemed to be doing all right after a visit to the vet in Vanuatu last month. She was having fewer seizures and even started swimming again.

But three days ago, Ducky started going downhill fast. Her legs could no longer consistently support her, and she was going blind and deaf. We put her in her big bed in the aft cockpit, babied her with special meals, and held her food and water in front of her because she could no longer sense them with her nose. She could hardly move.

Two days ago we arrived at beautiful Marau Sound on the southern tip of Guadalcanal in the Solomon Islands, and anchored off of Tavanipupu Isle. This lovely large bay is protected by many islands, and is very serene and peaceful. We decided that it would be the perfect final resting place for our Ducky. As her heart still beat strongly, it took until yesterday afternoon for us to get up the courage to give her the fatal injection. But as her quality of life was all but gone, we had no choice.

Coco and Jennifer's wonderful years cruising the South Pacific with their black lab Ducky will never be forgotten.

Giving Ducky the injection — with Greg holding her for me — was the most difficult thing I've had to do in my life. We took Ducky up on the foredeck for the afternoon, set her under a shady tarp in the cooling breeze, then gave her lots of hugs and kisses. After we said our last goodbyes, we gave her the shot. She slowly went into her final sleep with me cradling her head in my arms. At least she was with us in a friendly environment and not in some scary vet's office. After a little ceremony, we laid her to rest in the lovely bay.

For those who haven't had dogs, all this may seem silly. But it's been a very emotional time for us, and it's hard to accept that our loving companion is gone. We're trying not to be too sad by remembering all the wonderful moments we had with her. Ducky passed on at nearly 13, which is about 91 in 'human years'. So she had a long, full life for a big dog. Besides, how many labs get to adventure around the Pacific, snorkeling with family, chasing and being chased by sea lions, tackling turtles, barking at dolphins, swimming with whales, running and rolling on sandy beaches, patrolling the decks for flying fish during crossings, and protecting us from all perceived dangers?

So goodbye our beloved Ducky, The Duchess of Alamitos Bay, now resting in peace at lat 09°49.1S, long 160°51.1E.

—jen 09/15/10

Geja — '76 Islander 36 Andrew Vik Getting Groovy in the Med (San Francisco)

It's time to hang up the Speedos for the winter, as my third straight summer of cruising the Med aboard *Geja* — the San Francisco-based Islander 36 that I bought sight-unseen through an '07

'Lectronic Latitude article — has come to an end.

As of my last report, two Swedish crewmembers and I had just completed an overnight sail from Montenegro to Orikum Marina near Vlorë in mysterious Albania. Once checked into the country — a process handled efficiently and at no charge by the Italian marina staff — we took the communal mini-bus to the



scruffy seaside town of Vlorë for our first glimpse of Albanian life. The town itself was shabby in what I consider a Mazatlan sort of way, and featured little in the way of historic architecture. Its beaches, however, stretched for miles to the south of town, and were somewhat lively until sunset. The bay is certainly beautiful, and had Albanian leaders not isolated the country from the rest of world for decades, the area might have become a worthy tourist destination.

A full day in the region seemed to be enough, so we sailed on, crossing paths with just the second sailboat in as many days. A sometimes boisterous sail south brought us to Himara, a small beach town attracting residents from the nation's capital of Tirana. It was a pleasant place, though its many relatively swanky bars were empty. Since it was still July, perhaps it was too early in the season to find a good party. In any event, the three of us were feeling a bit sick to our stomachs, despite having eaten at only the nicer restaurants.

COCOKAI



Greg made up a bit for the loss of Ducky by landing a mahi.

COCOKAI





GEJA

For Vik, the highest 'wow-factor' of his third summer season in the Med was provided by Fiskardhon, Kefallinia in the Greek Isles.

Continuing along Albania's mountainous coast, we checked out two awesome lunch anchorages, where steep cliffs backed sandy white beaches and turquoise 77 degree water. Eerily, we had both wonderful anchorages to ourselves. One such anchorage was just six miles from the tip of lively Corfu, Greece. Nonetheless, there were no other pleasure boats; just a fishing boat or two. In fact, during three days of transiting the coast of Albania, we caught glimpses of only three other sailboats. For those who don't care for the crowds of the Med, this would be the place to be — in fair weather anyway. Call me overly social, but to me being in proximity to other people is one of the big attractions of cruising.

Sarandë, just spitting distance from Greece, was our southernmost Albanian stop. It is the nicest of the large Albanian coastal towns. The bay is surrounded by bland looking residential high rises,

most of which are half-finished and where progress has stopped. Check-in was handled efficiently by an agent for 35 euros, while a berth on their clean, pleasant, and secure commercial dock cost just five euros a night. Unlike the large and scary officials in Montenegro, the folks in this port were very welcoming, perhaps appreciative of our effort to visit Albania. The waterfront hosted a lively *passaggiata* each night, though the numerous bars were again empty. Even the open-air nightclub, which could host as many as 1,000, was heavily staffed but had few paying customers.

Albania, the mysterious country near the center of the Med, was certainly worth a visit. The locals were shy, nice, and always helpful. The prices were really low, and the countryside is wonderful — as we discovered by renting a car for a day. Unfortunately, the coastal towns are architecturally uninteresting, with few monuments of any

sort. In fact, the most unique structures are the small, round concrete bunkers that dot the coast and interior. Starting in '72, the Albanian government told the citizens to spend all their free time building these odd, heavily-fortified circular huts. Over the next 20 years, an astonishing 700,000 of them were built. Alas, there are no funds to remove these reminders of the paranoid communist past.



GEJA

From Sarandë, the Greek island of Corfu was clearly visible, and onward we ventured to begin a few weeks of cruising the Greek islands of the Ionian Sea. Just an hour's sail from Albania, we encountered a lush, green coastline, busy with small private yachts of all types and vintages. The check-in process was no less cumbersome than in non-E.U. countries such as Croatia and Montenegro, requiring stops at multiple agencies. Unlike in the E.U. countries of Italy and Slovenia, where checking in a foreign boat is free, Greece charged 60 euros to enter. The Greeks are also known to inconsistently apply taxes to foreign boats that stay in the country for longer than 90 days.

Corfu town, just 15 miles from Sarandë, lacks a proper guest harbor, and its grimy public quay is rat-infested. Fortunately, Mandraki, the private yacht club, had a berth for us. And what a stunning location the club has, just below the north side of Corfu's massive town fortress. The stroll into town involved meandering through two tunnels

Over 700,000 of these lasting monuments to communist central planning and paranoia were built in Albania starting in the '70s.

Over 700,000 of these lasting monuments to communist central planning and paranoia were built in Albania starting in the '70s.



GEJA

CHANGES

and over a footbridge to reach the heart of Corfu, a bustling university town that — thank to centuries of Venetian control — resembles Italy more than it does the rest of Greece. Corfu was the perfect weekend stop, with impressive nightlife and a convenient place to exchange the

Swedish crew for two Finns.

Given its size, Corfu actually didn't have much in the way of interesting nautical destinations, so it wasn't until we reached Paxos that the well-known nautical 'wow-factor' of Greece became apparent. Lakka, on the northern tip of Paxos, was excellent, with a huge turquoise bay and a perfectly cozy town. Further south, Gaios is an enormously popular town where little diesel and water trucks deliver their goods directly to your berth on the quay. The exposed western side of Paxos is stunning, with steep white cliffs plunging vertically into the clear sea, and there are numerous caves that can be explored in calm weather. Little Anti-Paxos, a stone's throw south from Paxos, has some spectacular beach coves — so spectacular that they seemed to attract every charter and excursion boat in the region.

Vik has found that female crew improve morale.

From the so-called 'Emerald Bay' on Anti-Paxos, we set sail for Parga on the mainland, just 12 miles away. About halfway across — and while we were enjoying a lively beam reach — the thundercloud to starboard that I'd been monitoring decided to 'erupt'. With the first drop in temperature and windshift, we quickly doused all sail. It was a good

San Francisco-based 'Geja' found the calm water quays of the Ionian Sea to be just to her liking. But she also thrived in brisk winds.

thing we did, because within minutes the sea to starboard became a frothy white, the likes of which I'd never seen before while on the water. Even with the motor running, all attempts to hold course against the wind and sloppy seas were in vain. Fortunately, we had sea room astern, and rode with the wind back to the familiar harbor in Gaios.

The following day, the Finnish girls and I made an uneventful 30-mile sail to Preveza on the mainland — though I did keep a wary eye on every cloud in the sky. Preveza has a long town quay with space for dozens of boats. Unlike in Croatia, Greece seldom fits its quays with lazy lines, which means everyone has to drop their anchor while backing up to the quay, hoping not to cross the anchor chains of other boats. With an inexperienced female crew and *Geja's* manual windlass, I was worried that we'd have problems. But pint-sized Vilja, who is a competitive fitness pole-dancer, was more than up to the task, muscling the 20 kg Bruce anchor up and down with enthusiasm.

Safely moored in Preveza, we noticed another contrast to Croatia. A similar spot in Croatia would have cost between 30 and 40 euros per night, including lazy lines, water, and electricity. While Preveza didn't have any such amenities, it cost nothing to stay the night. That's right, *nada!* *Geja* has solar panels, and I managed to connect a hose to a nearby irrigation system, so we were all set. As a result, the girls and I paid for just one mooring during the week, and that a reasonable 28 euros back at the Mandraki Harbor in Corfu. For the rest of the stay, the three of us spent a total of just 160 euros for berthing, onboard food, and fuel. A typical week in Croatia would have cost at least twice as much. No wonder few cruisers stick around Croatia for very long.

My next crew included Rob and Christine Aronen, vets of the '06 *Ha-ha* on their former boat *Nomad*. Now landlocked in Luxembourg, they are always happy to get their sailing fix on *Geja*. Along with Mari, a Swede who lives in San Francisco, we thoroughly explored the most interesting part of the Greek part of the Ionian Sea — meaning Lefkas and its surrounding islands. While the Aegean Sea of eastern Greece is known for its wind, particularly in



July and August, the Ionian is supposed to be mellow. This, however, proved to be absolutely not the case during our visit, as the wind howled. It made for great sailing, although some local knowledge would have been useful, as the winds wrap wildly around the half-dozen or so significant — and tall — islands of the region.

The more we moored in Greece, the more interesting it became. For not only does a spot on the quay cost nothing, there seem to be no rules about where one may settle in. We often found complete chaos, and crossed anchor chains were common. We saw boats Med-moor to light poles and to each other, while squeezing into impossibly narrow spots. The flotilla charter fleets have the benefit of a staff member who gets in a dinghy and directs anchor placement and takes lines to shore. Knowing how to park a boat is apparently not a requirement for chartering a boat in Greece.

Overall, the Ionian Islands of Greece

GEJA



GEJA



IN LATITUDES

ALL PHOTOS COURTESY GEJA

as even decent restaurants don't have seats on the bowls or toilet paper. How Third World is that? A totable toilet seat would be good cruising gear in Greece. But the biggest disappointment was the lack of a party scene. Despite our being there at the highest of high season, there was simply no decent partying aside from Corfu town. For a guy like me who appreciates a good night out, this part of Greece was not the place to be during the prime summer weeks.



Customers of the big charter boats in Greece were packed in like sardines.

In the November *Latitude* I'll wrap up my report of my third season in the Med — during which time I returned to the east coast of Italy and to Croatia — but I'll share some basic facts now. I was on the go for 81 days with 20 different crew, and visited 50 different places in five countries. I logged 1,400 miles, covering 43% of them under sail alone. The engine was on for 200 hours. Marinas are costly in the Med, and this summer we were typically charged between 40 and 50 euros a night, with the high being 60 euros. We stayed in marinas for 26 nights, though about half of those stays were avoidable. But sometimes paying for a mooring makes crew changes much easier, and sometimes it's good to give your boat a good scrub down and/or hunker down in bad weather.

But cruising the Med doesn't have to be expensive. Avoiding marinas is the best way to save. Groceries cost somewhat more than in the U.S., although

For Finns Heini and Vilja, Leg Four crew, the blue skies and waters of Greece were a nice change from the greys of Finland.



Clockwise from lower right; Mandraki Harbor. Greek food is simple and healthful. A blue water cove of Anti-Paxos. At Gaios, the water truck comes right to your boat. These kinds of crowded conditions make it clear that 'Geja' wasn't in Albania anymore. Another view of a cove at Anti-Paxos.

were a real treat. Fiskardhon on Kefallinia, was my favorite town harbor, while the cliff-backed day anchorage on Atokos provided the greatest wow-factor. Skorpios, Jackie Onassis' private island, was off-limits, while the "hurricane hole" at Vliho Bay near tacky Nidri was chock full of sailboats that would have fit right in with the anchored-out fleet on Sausalito's Richardson Bay.

Unlike Croatia's centuries-old buildings of limestone, Greece's earthquake-prone villages feature more modern construction and lots of color. The locals are lively and helpful, and those whose services we needed were fluent in English. The country's well-known economic problems were not noticeable to us, aside from a few conspicuously empty storefronts on main streets and a euro that cost about 20% less than in the previous two summers. Traditional restaurant

dishes such as *moussaka* could be had for about eight euros, though a couple of two-euro pitas were plenty filling. My only caution would be to watch out for the inexpensive table wine, which was bad more often than not.

There are some downsides to Greece, though minor. The stunningly scenic, steep-sided mountains we often had to anchor in 50 feet or more. Free mooring on those town quays is awesome, but without any electric connections, so you often find yourself next to boats running generators — and sometimes throughout the night. The regional transit systems are poorly designed, which caused some problems for my crew. The toilet situation is also poor,



GEJA

GEJA

CHANGES

Americans should appreciate that we pay less for packaged products than pretty much anywhere in the western world. A 'proper' two-course dinner with wine starts at 25 euros, though a hearty tuna pizza and a glass of house wine go for less than 10 — and even less than that in Italy. I pay 180 euros per year for full comprehensive boat insurance — though it took an inside connection to get full coverage for a boat that's 34 years old.

Another thing some Americans take for granted is the ease with which we can acquire specialty marine products. In the U.S., thousands of specialized marine parts are available off the shelf at a nearby West Marine, and many thousands more can be obtained within days from any of hundreds of online retailers. Not so in Europe. While

there are chandleries, they are mostly independent retailers carrying limited inventory. Ordering parts from elsewhere requires that the shopkeeper order it for you — assuming that some distributor in the country even stocks it. In Italy, you can't count on the shopkeeper to speak English — or any other foreign language. On top of the ordering hassles, you can expect to pay about 50% more for marine parts in Europe. In the case of *Geja*, it's far easier and less expensive for me to carry needed parts and spares with me on the flight from the States than to try to track them down in that part of the world.

Aside from the furler meltdown that I'll report on next month, *Geja* held up

It seems that there is no end to the beautiful Greek islands that dot the blue waters of the Ionian Sea. This little lovely is Parga.

AZURE II



Vilja, pole-dancer and anchor-lifter.

GEJA



like a champ! The toolbox was hardly opened during the summer, a sure sign of a trouble-free cruise and good off-season planning. *Geja* is a sweet, stiff ride, and her U.S. flag, San Francisco hailing port, and salty looks generated a buzz at nearly every place we stopped. It was the summer of a lifetime — for a third year in a row! As always, the options for next summer are to sail or sell. Stay tuned!

— andrew 09/20/10

X — Santa Cruz 50 David Addleman Cruising Malaysia (Monterey)

After spending a few years cruising Mexico with my Cal 36 *Eupsychia* — which I still have for sale — I bought a Santa Cruz 50 in Johor Bahru, Malaysia, and christened her *X*. After hauling her at Raffles Marina in nearby Singapore, I set out on my first trip — a three-day voyage to the 200-mile distant island of Pulau Tioman.

Far from the noise and smog of steaming Singapore and the hectic shipping in the vicinity of the export center, Tioman is a lush, mountainous island that makes her popular with tourists — as well as monkeys, cobras, butterflies, and other animals of the tropical rainforest. The island has a nice marina, a friendly island culture, many quiet places to anchor, and fabulous reefs for snorkeling. Not far north of the equator, the water is plenty warm. Groceries, fuel, and duty-free alcohol are all readily available. There is also a small international airport on the island, which made it easy for me to commute back to California.

Like everywhere I've been in Malaysia, the meals were very inexpensive, no matter if I was dining out or preparing them myself. Lunch and dinners usually cost \$2 or \$3, and somehow they manage to sell cans of Heineken for just 45 cents.

If I wanted to be thrifty, I would go to the open air markets, where I could buy a bag of fruit and veggies for 50 cents. Although they almost give the stuff away, the fruit and vegetables — of which I recognized about half — are of the highest quality. Malaysian beef, on the other hand, is very tough.

Pulau Tioman has a small cruiser community. Most of the cruisers are Aussies and Kiwis who



are doing a one- to two-year loop of that part of the world. They tend to favor heavy steel or ferro-cement boats. There's also a bunch of Germans and a few other European cruisers mixed in, but Americans seem to think this part of Malaysia is dangerous. The cruising culture is similar to that of Mexico in the sense that there's always a great deal of socializing going on. Since most Malaysians are Muslim, and most Aussies who aren't larrakins are pretty conservative, you don't have people drinking tequila shots out one another's' belly-buttons like some cruisers do in Mexico. But it's still the same cruising lifestyle that I find so satisfying.

After a couple of months at Pulau Tioman, I sailed east across what some claim are the pirate-infested waters of the South China Sea to Borneo. There had been some official reports of attacks on shipping, and while there is much folklore of cruisers being attacked, there were no recent verifiable evidence of it

IN LATITUDES



ALL PHOTOS COURTESY THE X-MAN



Spread; Typical Equatorial Belt clouds as seen from the harbor at Laubaun on the island of Borneo. Insets from left: Why should David freak about pirates when there is malaria? The Rainforest World Music Festival is a big deal. In fact, even the locals put on their party hats and started squawkin'.

that I could find. My only precaution was to swing well south of the Anambas Islands, which seemed to be the nexus of the problems for ships.

The whole piracy issue was a little worrisome to me, but I took comfort in the fact that I've got X so stripped down that I don't think any pirates would bother with her. Since I bought the boat, I've probably removed 2,000 pounds of what I considered to be excess stuff. Things like 100 pounds of paper charts, parts for boat systems that are no longer on the boat, heavy winch handles, brass clocks, and four mirrors. I only need one mirror — if that! I just leave the stuff on the dock and it disappears right away. X also has more heavy batteries than I want, so as soon as I find out which are the best, I'll get rid of the others.

Removing a ton of unneeded weight from my eight-ton 50-footer has made

a noticeable difference in performance — particularly in the weather conditions common in this part of the South China Sea. There is generally no wind at all — as one could deduce from the fact that I've done a lot of 50 and 75-mile days with a Santa Cruz 50. Mind you, this is an ultralight boat that will sail at almost five knots in just five knots of true wind.

It's true that X's sails are pretty pathetic, but still, if you look at weather charts for the Equatorial Belt, they're filled with random arrows without flags. Conditions are so docile that I haven't seen a single wave in seven months! It's like sailing on Lake Tahoe. The only time you get wind is in a squall, and then it's too much wind. Anyway, I spent five

beautiful moonlit nights sailing — except when I had to motor to keep from drifting backward into shipping lanes — the 400 miles until I dropped my hook in the Santubong River near Kuching, Sarawak, Borneo. For the record, Borneo is the third largest island in the world, with 73% of the land mass owned by Indonesia, 26% by Malaysia, and 1% by oil-rich Brunei.

There were a few cruisers when I arrived at the Santubong River, but with the approach of the Rainforest World Music Festival, the number of cruising boats

grew to 30. The festival is a famous showcase of world music performed by hundreds of musicians, and is attended by thousands of music enthusiasts. Each day began with orderly musical presentations in intimate workshops, but by the time the evening rain started falling, it had become a massive and muddy dance party. After the festival, I remained anchored in the river for a few weeks, enjoying the nearby city of Kuching, relaxing, and making friends.

Needing to find a marina where I could store X so I could return to California for a month, I continued northeast along Borneo's coast to Labuan, which has a reasonably good marina. It's about \$300 a month for my 50-footer, which I think is dirt cheap. Muslim Malaysia is supposedly so safe that you never have to lock your boat. We'll see when I return

Many Americans would be shocked to see how 'first world' and upscale many parts of Malaysia are. Per capita income is almost \$15,000.



X-MAN

Not all the (tourist) women in Muslim Malaysia wear burqas.



X-MAN

CHANGES

this month.

Like most Malaysian cities I've visited, Labuan is surprisingly as modern and glistening as any in the world. People have nice houses and new cars, and seem affluent. It's all the oil, gas and minerals in Malaysia. Everybody is very friendly and there have been absolutely



The Labuan Marina makes the Ala Wai look tawdry.

no personal safety issues. Processing papers at Labuan, as in all other major ports, was easy and nearly free. The cruisers all seem to have a wonderful time, so no wonder I can't wait to get back.

So far I have been singlehanded — and loving it. I stand watch when there's wind, which isn't often, and practice guitar, cook wonderful meals, read, or just gaze at the passing world. I sleep during the frequent calms.

I've only had two equipment failures in seven months, and they were minor. The anchor windlass had a couple of failures that I should have foreseen and been able to prevent. And the refrigerator apparently had a slow leak and stopped cooling my beer. After a few hours of looking around the shops in Kuching, I found a bottle of refrigerant and the parts to fix everything.

After loading up with cheap beer in duty-free Labuan, I'm not sure where I'll go. I don't like to make plans any more than two days out, but some cruising friends in Malaysia just wrote to say they are headed to Kudat, Borneo, so I may follow them there. On the other hand, I like the idea of sailing to Palau, the former U.S. Territory 2,500 miles to the east, which is noted for spectacular World War II wreck diving. The downside of that is that it's pretty close to the typhoon zone, so we'll just have to see.

— david 09/05/10

Malaysian veggies — as well as fruit — are delicious and inexpensive. Malaysian beef is inexpensive, too, but it's very tough.



X-MAN

Niki Wiki — Gulfstar Sailmaster Terry and Jonesy Morris Medical Care Outside the U.S. (Chula Vista)

Prior to doing the Ha-Ha four years ago, we wrote the following: "We quit our jobs, sold the house, sold the car and furniture, and got rid of all our stuff. We're now living aboard our 50-ft Gulfstar Sailmaster *Niki Wiki* about to start an open-ended cruise to Mexico, Central America, thru the Panama Canal, and into the Caribbean. We're going wherever our vagabond spirits take us."

Most recently our spirits have taken us to Guatemala, which is where we were when we read that the editor of *Latitude* was asking cruisers what they do about health insurance. The time of his request couldn't have been better, for two weeks ago I had emergency laparoscopic surgery to remove my gallbladder. The total cost was \$5,000 U.S. That included three nights and four days in the upscale and modern university hospital in Guatemala City. This cost included the surgeon, anesthesiologist, and primary care doctor fees, as well as all tests, medications, and follow-up care. It was one of my best hospital experiences, and I've had six other surgeries, all in the United States.

We have been cruising full-time for four years throughout Mexico, Central America, Panama, Colombia, and now Guatemala, without health insurance. Due to pre-existing health conditions, we are virtually uninsurable except through employer group policies — which means we'd have to work and not cruise. We made the decision to budget for unplanned medical care, and just took off cruising to live.

So far, we have been quite happy with the medical and dental services we have received. Jonesy, my husband, had an urgent and extensive root canal and crown procedure in El Salvador. It was done by an endodontist who was trained in the States. The total cost for two dentists and the crown was \$350. We have had routine teeth cleanings and check-ups for between \$25 to \$40, and filling repairs for \$25 — all by English-speaking dentists. A walk-in, same-day mammogram at a private hospital was \$35, with the typed radiologist report and films available for pick-up the next day.



Routine blood-work is done inexpensively on demand at laboratories.

Both Colombia and Guatemala advertise medical tourism, which is why people travel to these countries to get elective or other surgeries not covered by their insurance. It's done at greatly reduced prices. There are English-speaking individuals who will arrange whatever medical services you might require. Among the cruising community there are always other folks who will gladly give recommendations of doctors, dentists, and lab work. We have often relied upon this network, and have never been disappointed.

I'm recovering rapidly while lounging by the pool and playing Mexican Train dominoes. We are looking forward to leaving this hurricane hole in the Rio Dulce at 'Mario's Marina and Summer Camp for Cruisers' so that come November we can head back out to sea to explore Belize and the Bay Islands of Honduras.

— terry 09/20/10



Inset; Terry, minus her gall bladder, and Jonesy in the Rio Dulce. Spread; Can you identify this month's 'Mystery Island'? We're stumped.

**Sea Level — Schionning 49
Jim and Kent Milski
Surfing and Flipping
(Colorado)**

To give you an idea of how cold the California coast has been this summer, Jim came back from his and Kent's cat at Vuda Point, Fiji, to surf Imperial Beach, which is just south of San Diego. "Thanks to a cold upwelling, it was 59 degrees. That's terrible!" he said.

No kidding. Especially when you've become accustomed to surfing the warm waters of Mexico and the South Pacific. "The water had to be 80 or 82 degrees in Fiji when we left," continued Jim. "It's 'no wetsuit' surfing in the tropics — although we do wear a light suit if we're going to be snorkeling for an extended period of time. Another nice thing about surfing in the South Pacific is that unlike some places in Mexico, there are no sea urchins."

The downside of surfing in French Polynesia, of course, is that you are almost always surfing the edge of a reef. "We haven't seen a sand beach since Mexico," laughs Jim. "During every session, I'll make contact with the reef a couple of times. But the good news is that the reefs are kind of flat instead of being jagged."

Like most surfers, Milski didn't want to reveal the lesser known locations he's surfed, but he says he's found good surf in the Tuamotus, and great surf in French Polynesia. One of the well-known spots he hit was Huahine. "There's one break for longboards, and another for short boards," he says. "While there, we met Liz Clark of the Santa Barbara-based Cal 40 *Swell*. What a jewel of a person. She's just wonderful!"

Jim and Kent were in Niue when Kelly Wright arrived on the ship that rescued him after *Anna*, his New Mexico-based Atlantic 57 catamaran,

flipped and had to be abandoned. "We'd seen the storm coming on the GRIB files," says Jim. "In fact, we — along with two Aussie boats and a Belgian boat — saw what was coming while we were up at Palmerston, so we rushed to Niue to grab mooring buoys. It was a good thing, because we had gusts into the mid-40s come through. We assume that the guys on *Anna* saw the GRIB files, too."

Niue, known for rocks, not good anchoring.

"When you get GRIB files from SailMail," Milski continued, "you can also pull one down that shows how much moisture there is in certain areas. The chart comes out shaded or black where there is lots of moisture, so you know it's a low. We could all see it. And when Wright says they were hit by over 60 knots of wind, I believe him. For there were some guys from Indiana on a boat called *Bubbles* flying a chute toward Tonga, the opposite way *Anna* was headed, and they got hit by 60 knots. Fortunately, they got the chute down in time. We later attended a weather class in Tonga, where the instructor explained that *Anna* had flipped in an area where two lows had come together."

Kent, who spoke extensively with Wright and his crewman Glen McConchie, said she was told that the cat had paused when she was heeled over about 45 degrees. "Kelly and I both gave each other that 'she's gonna come back down' look," McConchie told her, "but then she continued all the way over."

McConchie had some other advice for Kent. "Don't ever mount the EPIRB high up in the salon. Even though I was inside *Anna*, since she was flipped I had to dive down into the water mixed with

Cruising cats have become more popular in the last 10 years. They are most popular, however, when they are right side up.



SPREAD, COCOKAI; INSET, NIKI WIKI

DENISE DE MENICE



LATTU DENICK

CHANGES

boat debris to try to get the EPIRB. I bet that it took me 18 dives before I was able to get it. Part of the problem is that it's very disorienting when the cat is flipped, so I spent a lot of time looking for it on the wrong side of the bulkhead."

McConchie was also able to answer the question of why he couldn't get out the escape hatch. Over the years, some escape hatches on cats have leaked or even been holed. As a result, *Anna* was built with a solid plastic window instead of a hatch. A hammer was mounted next to it so the window could be smashed in the case of an emergency. Unfortunately, the window was too strong for the blows from the hammer — as well as for blows from a fire extinguisher and anchor! So having been inside the hull for 15 hours, McConchie ultimately had to swim out a deck hatch in what had become the bottom of the flipped cat.

While the flipping of *Anna* proved that even very large cruising cats can capsize if greatly overpowered, Jim and Kent are confident their *Sea Level* won't because they are very conservative with how much sail they set. Not only did they sail from Mexico to Polynesia with two reefs in the main at all times, but they now often sail with just a headsail and no main at all.

"Having sailed *Sea Level* so many miles now, we've learned that in reasonably strong winds we sail almost as fast without the main as we do with it," says Jim. "And it's always much more comfortable with less sail. We might only do 6.5 knots instead of 7 knots, but if we get hit by a big squall, we can quickly furl the headsail or even more quickly release the sheets. I also really like the idea that *Sea Level* doesn't have the mini-keels that *Anna* had in addition to her daggerboards. It's my understanding the blast of wind blew *Anna* around until she was beam to the seas, at which point the cat tripped on her leeward mini-keel. I've

Wayne and Carol are headed to the South Pacific after years in Mexico. They sail conservatively, so they don't fear flipping 'Cap Cat'.



also seen cats that have a lot of control lines run through sheet-stoppers to a single winch. I don't like that. We have dedicated winches for each mainsail control line, so they can all be released instantly. Kent and I are aware that it's possible that our cat could flip, but because of how we sail, we're confident that she won't.

When back in San Diego, the Milskis stayed with Wayne Hendryx and Carol Baggerly aboard their Hughes 45 *Capricorn Cat*. "We're aware that cats have the potential to flip," says Hendryx, "which is why we are very conservative with how much sail area we carry. After buying the cat from Blair Grinols, we got hit by 35 to 45 knots of wind while sailing south off the Central Coast of California. But as we had no main up and only 25% of the genoa unfurled, the boat handled the conditions so well that we could enjoy dinner while the autopilot drove. We usually take the main down at night, and even during the day we'll often sail with one or two reefs. With cats, a couple of reefs don't slow you much."

"Blair brought *Capricorn Cat* 5,000 miles home from the Marshalls on three different occasions," continues Wayne. "He told me that he often got going to weather so fast that the cat would leap over the crests and come slamming down. His solution was to furl the genoa completely, triple-reef the main — and deploy a Gale Rider drogue from the transom — even though he was sailing to weather! It worked

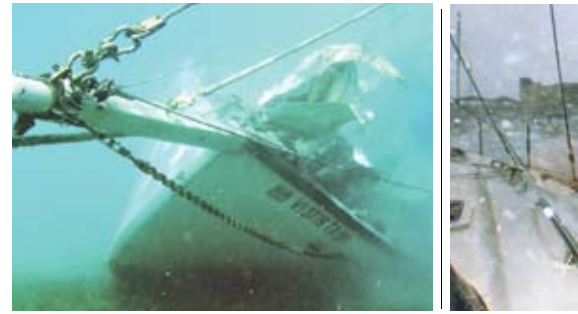

great for him."

As for the Milskis, they are delighted with the cat that Jim built from a kit. "*Sea Level* is the perfect boat for us," Jim says. "And what's really neat, is that she's always teaching us how she likes to be sailed. It makes it really fun."

Jim and Kent are also really enjoying the international group of cruisers they're meeting in the South Pacific. "There are quite a few Europeans out here," says Kent, "many of them with brand new or near-new boats. And just about all of them are equipped with first class stuff. They're good sailors, too."

"We've also run into about 10 boats that were bought in the U.S. by Aussies, Kiwis, or Europeans, and that are being sailed to New Zealand and Australia," says Jim. "The belief is that they can be sold for a big enough profit to pay for their year or two of cruising. Of course, there are still a number of very adventurous folks on smaller boats and even smaller budgets. We met one couple on an engine-less 29-footer that took 40 days to make it from the Pacific Northwest to San Francisco. You can imagine the stories they have to tell."

— latitude/rs 09/09/10



IN LATITUDES

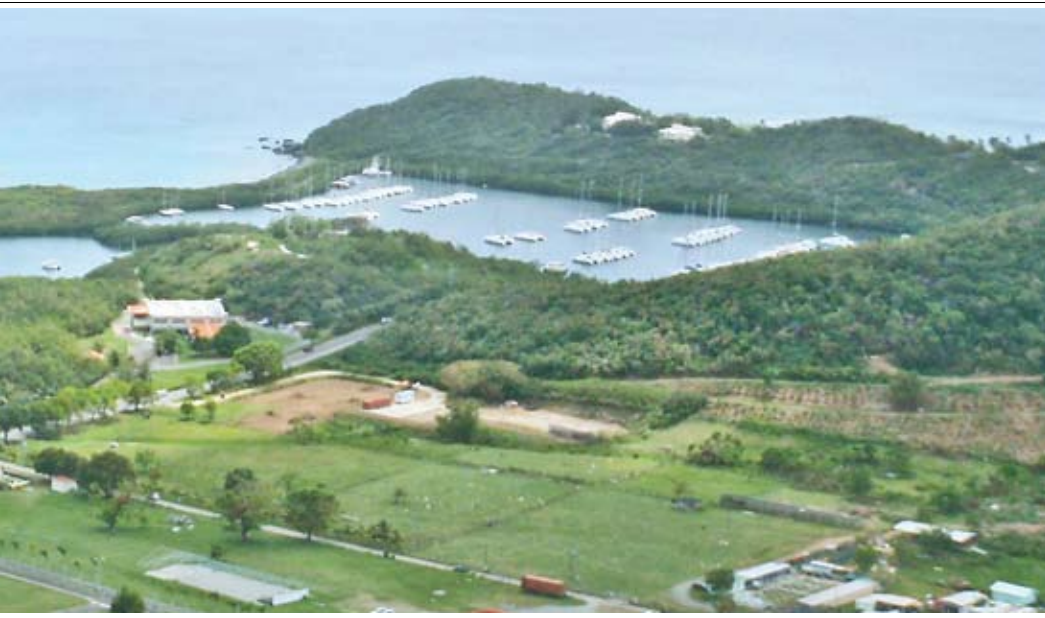

Top spread and right; Paraquita Lagoon served the charterboats well. Middle; During a lull in 'Earl'. Left; A boat on the bottom at St. John.

Cruise Notes:

The streak of boating interests in the northeastern **Lesser Antilles** not being hit hard by a hurricane in many years was nearly broken in late August and early September by the trickster **Earl**. He was forecast to be a mild Category 1 hurricane that would sweep to the northeast of the islands at a reasonably safe distance. Further, all the islands would be in the least dangerous southwest quadrant. But you can't trust a hurricane any more than you can trust a politician, and at the last minute *Earl* not only strengthened to a become a powerful Category 4 hurricane with winds to 125 knots, but decided not to veer as far to the northwest as he was supposed to. That meant the islands from Antigua to the U.S. Virgins got a bigger scare and were hit harder than originally expected. As he closed on the islands, *Earl* also became a much broader storm. The result was that all the boats on the south side of islands — such as Tortola in the British Virgins, the center of the bareboat charter universe — which had land

between them and the leading edge of the hurricane, ended up being lashed by the southerly winds of *Earl's* tail. Getting lashed by southerly winds from a hurricane that passes to the northeast of you in the northern hemisphere is weird, but that's what can happen if the hurricane covers a large enough area. The following is an eye-witness report from a frequent *Latitude* contributor — who doesn't want his name used because he doesn't want his insurance company to know his boat was in the British Virgins and not 400 miles to the south at Grenada, and outside the hurricane zone:

"My boat and I were at Village Cay Marina on the south side of **Tortola** near The Moorings base. *Earl* started with winds from the northwest at 45 to 48 knots, but as we had the tall island between him and us, and no fetch, it wasn't bad. But by 10 p.m., the wind had backed 90 to 100 degrees and was coming out of the south at 70 knots! Everyone who had secured their boat for northwest winds scrambled to adjust their lines for winds from the south. The two sets of wind instruments atop my 70-ft mast read a constant 74-78 knots from the south for three hours during the

worst of it, with a high gust of 86 knots. I'd removed everything I could from the outside of my boat, and had her secured by 12 strong lines. While Tortola suffered lots of downed trees and power lines, and there was no electricity or lighting at night, my boat wasn't damaged. In fact, there was no damage to any of the 25 other boats in the marina. However, many of the boats anchored or moored out — and even commercial vessels including inter-island ferries — were badly damaged."

It was odd how *Earl's* tail had done most of the damage, and the pattern of destruction was equally unusual. Some boats were lost at **St. Barth** — where boatowners had been told to expect only 40 knots — and a big sailing vessel was lost at **St. Kitts**. On the other hand, we got few reports of damage at the huge sailing center of **St. Martin**, and the folks at the yard in Spanishtown on **Virgin Gorda** said they didn't have any boats blow over. Thanks to the great hurricane hole at **Paraquita Lagoon** on the south side of Tortola, the Sunsail and The Moorings charter yachts did fine, as did our Leopard 45 cat **'ti Profligate** and the other boats in the BVI Yacht Charters fleet. Indeed, just two days after *Earl* passed, *'ti* went out on charter. The boats at Tortola's West End/Soper's Hole, on the other hand, were hit pretty hard because they had no protection from the northwesterly winds coming from the leading edge of *Earl*.

Tom Larson, who did the Ha-Ha in '05 with his wife Amy aboard their Tiburon-based Yorktown 35 **Sandpiper**, then nearly circumnavigated, reports that there was quite a bit of damage to boats on the exposed south side of St. John in the U.S. Virgins. "*Earl* took out all 10 boats at Chocolate Hole, four boats at Cruz Bay, and several others in Coral Bay — even though we only got sustained winds of about 40 knots and gusts up to

'Earl' surprised everyone by suddenly becoming so well-defined. The breadth of the storm brought southerly winds to many islands.

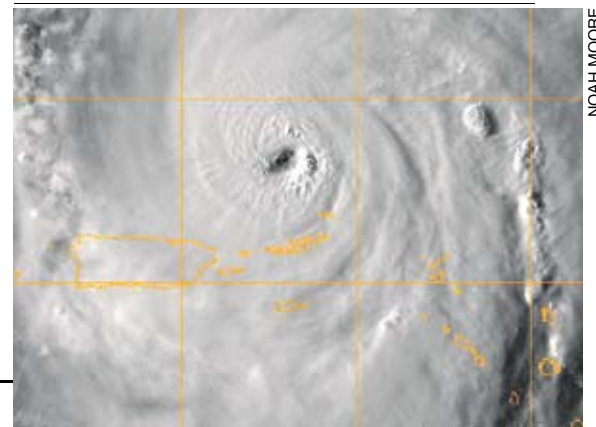

SUNKEN BOAT PHOTO BY FRANKLIN TULLOCH; ALL OTHERS BY KARL ILLACKER

NOAH MOORE

CHANGES

60 knots.”

The bottom line is that *Earl* could have been a much more destructive storm. So the Eastern Caribbean’s streak of good luck continues. But keep your fingers crossed, because hurricane season doesn’t end there until December 1.

To prove once again how quickly and abruptly cruisers change their plans, Tom and Amy Larsen spent nine months in Australia before deciding to sail *Sandpaper* up the Red Sea and then cross the Atlantic. They stopped in St. John in the Caribbean to visit some friends, expecting to continue on up to Charleston, South Carolina, to look for work. But while they were having a “few rums” the night before they were to leave, the charter trawler *Sadie Sea* pulled up to the waterfront bar where they were drinking. To make a long story short, they bought the trawler and sold *Sandpaper*, and are now in the charter trade in the Virgins.

While all of Mexico’s strong hurricanes have stayed offshore so far this summer, that’s not to say that the **Vallarta Coast** didn’t get clobbered by Mother Nature. According to John and Gilly Foy of the



DICK MARKIE DISASTER PHOTOS

When the bridge for the main highway over the Rio Ameca collapsed, this boy finally had an acceptable excuse for being late to school.

Alameda and La Cruz-based Catalina 42 **Destiny**, it rained over 13 inches in one night! Sure, summer is the rainy season on the Mexican mainland, but that was a month’s worth of rain in less

than 24 hours. The result was that a 150-ft section of the northbound two-lane bridge between Puerto Vallarta and Nuevo Vallarta collapsed in the middle of the night. With the separate southbound bridge carrying Highway 200 traffic having to be closed to check for damage, the tens of thousands of people to the north of the river, as well as all the supplies coming from Guadalajara, didn’t have a way across or around the raging river. So people who absolutely had to get to the other side of the river gathered in the parking lot in front of the Vallarta YC at Nuevo Vallarta, and were eventually transported to Marina Vallarta and the downtown area by an armada of 150 boats of every size, shape and description. Farther up the Vallarta Coast, the popular surfing/tourist town of **Sayulita** was completely cut off after its connecting bridge to the main road collapsed. Mexico being Mexico, roads were quickly cleared and ways were found to get people and goods where they needed to go. By the time anyone in the Ha-Ha fleet makes it to the Vallarta



INSURING YACHTS FOR OVER 50 YEARS

Providing Cruisers and Racers All Over the World
with Prompt, Reliable Service since 1959

Contact Us for a Quote



Exclusive
MARINERS Odyssey® Program

- Mexico
- South America
- South Pacific
- Caribbean
- Mediterranean

Racing Sailboat Program

- TransPac
- Pacific Cup
- PV / Cabo Races
- Caribbean Regattas

www.marinersins.com

QUALITY COVERAGE AVAILABLE IN MEXICO

Mariners Insurance Mexico offers insurance programs for health, homes, autos, motorcycles and yachts in Mexico.

www.marinersmexico.com

Corporate Office: 206 Riverside Ave., Suite A, Newport Beach, CA 92663 / Ins. Lic. #0D36887



Seattle
800-823-2798

N. California
boomeins@aol.com
800-853-6504

L.A./Orange Co.
800-992-4443

San Diego
800-639-0002

Puerto Vallarta
52-322-297-6440

East Coast
Bradenton, FL
800-914-9928



area in mid-November, the rainy season will have ended, and we're confident the major problems will have been sorted out. As for the jungle along the Vallarta Coast, it said to be growing like never before. It's going to be something to see before mid-November, when the end of the rainy season and the drop in humidity naturally trim it back.

"We motorsailed our family's nomadic 97-ft brigantine **Talofa** on a Baja Bash last month after five great years in the Sea of Cortez," write Beau, Lianne and Clint Bryan. "We departed Cabo San Lucas on July 7 into the usual 30+ knots off Cabo Falso, but from then on the wind and seas progressively eased off, allowing our group of eight adults, a two-year-old, and two dogs to really begin to enjoy ourselves. We caught a large yellowtail and eight Pacific bonito. Peter Domeq, our midnight watch captain — who is also founder of San Jose del Cabo's cultural/community center Raices & Brazos, and its in-house restaurant Sabor de Amor — prepared delicious sashimi platters and many other gourmet pescatarian

meals. We anchored at both Bahia Santa Maria and San Juanico to surf a small south swell. On July 19, a dozen days out of Cabo, **Talofa** eased into her slip in Channel Islands Harbor in Oxnard. From now until the October 24 start of Ha-Ha XVII — we had so much fun we've got to do it again — we'll be taking groups of six passengers on multi-day sails to the Channel Islands. In addition, we'll be showing up for **Buccaneer Day** at Two Harbors, Catalina, on October 2. We had a piratical time at Buccaneer Day in '05, so we'll be bringing extra black powder this year. So ye boarders, beware!"

Once you get a taste of the warm waters of Mexico, it's hard to stay in chilly California, isn't it?



Uninhibited pirates, saucy wenches with pistols, Buffalo Milks all along the bar — it's a recipe for . . . well, you never can tell.

"Our experiences with health services in Mexico are very much in line with what you reported in the September 20 'Lectronic,'" writes Jimmie Zinn of the Point Richmond-based Morgan 38 **Dry Martini**. "On three separate occasions we encountered competent care, modern facilities, great service, and very reason-

Your Boatyard in the Heart of Paradise



Large, fenced, secure dry storage area

Tahiti Customs policy has changed!
Foreign Flag vessels can stay on dry storage in our yard for up to 12 months out of 24.

Our Services |

HAULOUT

- Marine Travelift 25 tons
- Marine railway 120 tons
- Storage in adjustable steel cradles
- Fenced Yard

PAINTING

- Topsides, hull, bottom, varnish
- Brush, roller, spray

MECHANICAL WORK

- Inboard, outboard, diesel, gas
- All brands

REPAIRS

- Electrical repairs
- Refrigeration installation & repair
- Fiberglass & woodwork
- Welding, steel, stainless, aluminum

SAIL LOFT

- Sail repairs, biminis, dodgers, covers

STORE

- International, Pettit, Epiglass, Devoe
- Spares
- Fill U.S. gas cylinders

DO-IT-YOURSELFERS WELCOME!

BoatUS Cooperating Marina



Professional boatyard in the heart of Paradise



A Subsidiary of
The Moorings Yacht Charter, Ltd.

Raiatea Carenage will make sure
paradise is everything you expected.
Call, write, or sail in . . . we're here to serve you.

B.P. 1111 Uturoa Raiatea 98 735 Polynésie Française

Tel: (689) 600-545 ~ Fax: (689) 600-546 ~ VHF 68

Web site: <http://www.raiatea.com/carenage> ~ email: raiateacarenage@mail.pf

CHANGES

able cost. However, we did have one negative incident that justifies a word of caution. While in La Paz, Jane and I went for dental hygiene appointments with a local dentist who had been highly recommended by some of the stationary cruisers in La Paz. Jane saw the woman on Tuesday, and I was scheduled for Thursday. When Jane returned from her appointment, she reported being surprised to learn she had three loose fillings that would need to be replaced. But the red flag went up when, during my Thursday appointment, I was told that I had three loose fillings, too. What a coincidence! Jane naturally cancelled her appointment. While taking care of business back home eight weeks later, I paid a visit to my dentist of 30 years. He advised me that my three loose fillings had miraculously tightened back up by themselves! Although I don't like telling a story like this because it's certainly not typical of Mexico, I think it's important that people know about such experiences. In nearly four years of cruising in Mexico, this was one of only two slightly troubling experiences we had."

We're big believers in the truth be-



LATITUDE/NICK

"I have some very good news for you, senorita. The cause of your discomfort is a loose tooth. No, really, I'm not making this up."

ing told, Jimmie, so we're glad that you shared your and Jane's less-than-satisfactory dental experience. It reminds us that a dentist popular with cruisers in Puerto Vallarta was accused of some-

thing similar. Like you, we think these are isolated instances. The good thing is that ultra low prices in Mexico mean that it doesn't cost much to get a second opinion. And because the cruiser community is so tight, such scoundrels are quickly exposed. Open wide!

By the way, after reading the report that Terry Morris of the Gulfstar Sailmaster 50 **Niki Wiki** had a very satisfactory laparoscopic surgery to remove her gall bladder in Guatemala at a price of \$5,000 for everything, a *Latitude* staffer was stunned. Her partner had had the same operation at Marin General in Marin County, and the bill came to \$80,000.

Two "hot girls" looking for a killer to sail with them as crew. In order to prove once again that truth is stranger than fiction, we present the following 'Crew Wanted' ad that appeared on Craigslist:

"This is a chance of a lifetime! My best girlfriend and I are planning to come into some money soon. We plan on living the dream, buying a large sailboat and just traveling around the world. Although

You're invited to...

Drop Anchor

at the Pittsburg Marina!



(925) 439-4958
www.pittsburgmarina.com
 51 Marina Blvd. ~ Suite E
 Pittsburg, CA 94565

- NEW GUEST DOCKS
- NEW FUEL DOCKS
- Valvtect Marine Fuels
- Saturday Farmer's Market in the summer
- Delta Discovery Cruises
- Delta View Golf Course
- Many nearby restaurants



OFFICIAL SPONSOR



quite adventurous, we are only two small young girls, thus quite defenseless. Well, we could theoretically defend ourselves, but we will most likely be drunk most of the time and thus not in the right state to be on the lookout for pirates or rapists. I'm not sure I would be very good shooting a pirate with double vision. I tried going to the gun range, while hammered, to practice, but for some reason they would not rent me a gun. I tried explaining my fear of pirates, but that just got me physically carried out. Apparently yelling, 'But how will I fight the pirates? They could come at any moment!' caused some sort of distrust between me the gun range man. Personally, I think he must have been on some sort of power trip. Anyway, all we need is one strong, fearless man to kill any pirates we come across. If you have killed a man before, that could be a plus. If you have any pirate-killing experience, you are a definite shoo-in. You may be the luckiest man you know and the envy of all your friends. You will be able to travel the world, lie in the sun all day with two hot girls, and explore a different city every week without a care

in the world — except pirates. I cannot stress this enough. We may from time to time ask you to help fish or man the sails, but your main concern and number one enemy is pirates. Also, if you are anything like Kurt Russell in *Captain Ron*, we encourage you to apply."

"The **Reef Shipping** supply ship arrived in Niue today, and upside-down on deck was the Atlantic 57 catamaran **Anna** that had flipped on her way to Tonga in August," report Bruce and Alene Balan of the Northern California-based Cross 45 trimaran **Migration**. "We don't know the cat's final destination, but it's very sad because she was a beautiful boat when upright the last two times we saw her — which was at the boatyard in Whangarei, New Zealand, in February, when we were hauled, and



MIGRATION

The Atlantic 57 catamaran 'Anna', daggerboards pointing to the sky, leaves Niue as deck cargo presumably bound for New Zealand.

then again in Lifuka, Tonga, a few days before she departed for Niue."

"As for ourselves," the couple continue, "we arrived Niue last week after sailing upwind from Tonga. We just had to return to Niue, as we really love this island. We missed the whales here last year because we didn't arrive until Oc-

Welcome Baja Ha-Ha Cruisers...

To the three best Marinas in Southern California!

Whether you're heading north or south or simply want to find somewhere to stay for a while, our marinas...

Ventura West Marina, Dana West Marina and Harbor Island West Marina are the places to stay for convenience, comfort and friendliness.



Ventura West Marina
805.644.8266
1198 Navigator Drive
Ventura CA 92001
www.venturawestmarina.com

Dana West Marina
949.493.6222
24500 Dana Pt Harbor Dr
Dana Point CA 92629
www.danawestmarina.com

Harbor Island West Marina
619.291.6440
2040 Harbor Island Drive
San Diego CA 92101
www.harborislandwest.com

CHANGES

tober. There haven't been many whales yet this year, but it might all change, as three whales came through the mooring field this morning. We instantly grabbed our masks and jumped in, and had a wonderful 15-minute swim with them. The water was crystal clear, and between trips to the surface to breathe, the whales just floated calmly beneath us. Awesome!"

Convergence, the cat ketch-rigged Wylie 65 with freestanding masts owned by West Marine founder Randy Repass and his wife Sally-Christine, was first to finish in the Sail Indonesia Rally that started from Darwin in late August. According to the ever-more legendary Commodore Tompkins of the Mill Valley-based Wylie 38+ **Flashgirl**, who was along as crew with his wife Nancy, "The 550-mile event to Banda was billed as a race, but was so low-intensity as to be more of a cruise. There were several 50-ft catamarans with us, but it was all downwind in moderate breezes, allowing *Convergence* to average just under 10 knots."

Nancy had a more feminine take on



NANCY POTTER

The residents of Banda were happy to put out a big welcome for Randy, Sally-Christine, Commodore, Nancy, and the rest of the fleet.

the event. "It was a bit confusing because there were at least four events within Sail Indonesia starting at the same time: 1) Race to Banda, 2) Race to Ambon, 3) Rally to Banda, and 4) Rally to Kupang.

Convergence was entered in the race to Banda along with 10 other boats. The sailing instructions had such a short time limit that only three boats finished in time. It was a bit lumpy crossing the Arafura Sea, but the seas smoothed out nicely once we got inside the island group. When we arrived in Banda — one of the famous 'spice islands' of old, where nutmeg was discovered — the locals made quite a fuss over us. It turns out that Indonesia has invested some serious money in promoting sailing and tourism, and we were the beneficiaries."

Currently in the process of touring Bali, Java, Borneo and Sulawesi, Commodore and Nancy will soon return to *Flashgirl* in Queensland, Australia, and resume their cruise north inside the Great Barrier Reef. As for *Convergence*, we presume she's continuing on her way through Indonesia toward Malaysia and Thailand. As we mentioned in a previous *Cruise Notes*, quite a number of Ha-Ha vets were among the 120 or so boats signed up for one of the Sail Indonesia fleets. Sail Indonesia is

Ventura Harbor Boatyard

A First Class Full Service Facility

(805) 654-1433



Official Sponsor
2010
BAJA
HA-HA

S/V Talofa

Two Travelifts ~ Haul Outs to 160 Tons
Experienced Staff * Competitive Rates

"Do-It-Yourselfers Welcome"

1415 Spinnaker Drive, Ventura, CA 93001

www.vhby.com

ENSENADA'S ONLY
RESORT MARINA

\$12.60 PER FOOT

SHUTTLE SERVICE TO USA! AVAILABLE

Enjoy our 2 month special rate that includes, live aboard, access to our amenities, complimentary weekly shuttle to town, WIFI & Cable T.V. service included. Plus get a preferred discount on clearance assistance with Customs. Only fuel dock in Ensenada | Pets are welcome

OFFER EXPIRES ON NOVEMBER 30, 2010. RESERVATION CODE: CRUISERS 2010
Rates shown are in USD. Additional taxes/fees or restrictions may apply.

FOLLOW US IN:



HOTEL CORAL AND MARINA

1 (866) 302-0066 | VHF 71
marina@hotelcoral.com
www.hotelcoral.com

noted for not being the most organized event, so it's still unclear which of these boats started and how they might have finished.

"We're slowly bringing our Island Packet 370 **Kwanesum** back to the Bay Area, having left Virginia in September of '08," report Ellen and Randy Hasseness. "Our boat is currently under the watchful eye of Tim at Land Sea Marina in Golfito, Costa Rica, as we're back in the States taking a break from hurricane season to visit family and friends. Come October, we'll head northwest to Mexico and ultimately San Francisco Bay. As you can tell, we don't move too quickly, but we've had wonderful adventures. Like the Wanderer, we saw 36-year-old Russian Andre Melnichenko's futuristic-looking 396-ft mega motoryacht **A** in St. Barth. After a wonderful trip down the Leewards and Windwards, and stops at Bonaire, Curacao, Cartagena and the San Blas Islands, we transited the Canal. When heading to Flamenco Marina to fuel up for our trip to Costa Rica, we saw **A** anchored there, too. What we're

really hoping to see is the Ha-Ha group off the coast of Baja in early November. We'll be going in the 'wrong' direction, but what the heck. While there is still lots for us to see, we can't wait to sail beneath the Golden Gate Bridge, flying the flags of all the countries we've visited. We'll definitely have big grins on our faces as we cover the last few miles to our new 'boat home' at the Oakland YC. Rum at 5 o'clock!"

Think what you may of Swiss **Ernesto Bertarelli's** stewardship of the America's Cup, but he has stepped up when it comes to helping protect the **Chagos Archipelago** in the middle of the Indian Ocean. Administered by Great Britain as a British Indian Ocean Territory, the Chagos group lies 300 miles south of the Maldives, and is at roughly the midpoint



The Chagos Archipelago in the Indian Ocean, one of the most pristine marine environments left, and a favorite of adventurous cruisers.

between Sri Lanka and Madagascar. It's comprised of seven atolls that contain more than 60 islands. The remote Chagos is regarded as having some of the cleanest waters and healthiest reef systems in the world. It's also considered to be one of the greatest cruising destinations in the world. 'Mr. Alinghi' offered more than \$5 million to support the region's newly designated Marine Protected

New Member
Showers and
Laundry Facilities
Now Open!

NEW SLIPS!

Now taking reservations
for 40' to 60'

Emeryville Marina

ON THE BAY

When you call Emeryville Marina Home...
...call this your backyard!

Free Wi-Fi
and Video
Surveillance

Slips from 20-65 ft
Full Amenities - including
Fuel Dock & Pumpout Station

(510) 654-3716

www.emeryvillemarina.com

CHANGES

Area (MPA), which covers a quarter million square miles of ocean surrounding the archipelago, and includes blanket restrictions on commercial fishing.

There has been no checking out for Steve Schmidt of the Caribbean-based custom cruising Santa Cruz 70 **Hotel California, Too**. It must be more than a decade ago that he and his then-wife Barbara, who had been living in Saratoga, sailed to the Caribbean aboard one of the more basic ultralight cruising boats ever. After a few years of cruising, Barbara decided to return to the 'real world' in Santa Barbara, first living on land and now on another sailboat. Steve, on the other hand, has continued to race and cruise in the sunny Caribbee. We'd last seen him in Antigua in '05, so we didn't even recognize each other when we crossed paths in the marina in Santa Barbara in September. He reports that even after all this time, he's still passionate about sailing in the Caribbean and racing, both on his SC70 and on other big boats. Steve spends eight or nine months a year in the Caribbean, then about three or four months in the Santa

Barbara area where he has family and loved ones.

"Hola! I just wanted to alert everyone headed south to the fact that the sea lions that deserted Pier 39 a while back seem to have taken up residence here in Ensenada," reports **Harry Hanssen**. "There are about 300 to 400 of them. While tourists are sold food to feed the sea lions at Pier 39, feeding them in Ensenada can get you arrested!"

We doubt the **sea lions** in Ensenada are the same as those at Pier 39, but sea lions are a problem nonetheless. They pile on boats in such numbers that they've sunk even large ones, their endless barking can make sleep almost impossible for those on boats and in waterfront homes — and they are inattentive when operating motor vessels. As the *L.A. Times* reported last July, two Orange County sheriff's deputies had a problem when they lured a sea lion — who had been nipping at people on a dock — onto their boat for release

away from humans. While the deputies were in the boat's main control area, the sea lion snuck over to the foul-weather station, which has a secondary steering wheel and set of controls. Before the deputies knew it, the patrol boat's emergency lights, deck lights and various other equipment began going off and on, and the boat "seemed to be steering itself." Upon investigation, the sea lion was found sitting in the operator's seat, randomly flipping switches. A helm hog, the sea lion tried to bite the deputies when they tried to displace him. In full compliance with the terms of the Marine Mammal Act, the sea lion was chased away with water from a hose.

More bad luck. After suffering a severe break when his leg got caught on a wildly flapping genoa sheet, Greg Dorland of the Tahoe-based Catana 52 **Escapade** reports that his boat was hit by lightning while in Annapolis. It's not clear when Dorland's leg and/or *Escapade* will be ready to cruise again. If you're one of the ones about to begin a season or more of cruising, count your blessings, be safe — and don't forget to write!

Come to Mexico and repair your boat at

OPEQUIMAR

MARINE CENTER CENTRO MARINO

Puerto Vallarta

88-ton (max) Travelift!
Length to 100'
Width to 23'

México AEROTRON RIVIERA NAYARIT PUERTO VALLARTA

www.aerotron.com El Paraíso del Pacífico Mexicano Where Mexico Comes to Life

www.opequimar.com

fuel dock • full service boatyard • brokerage • 88-ton Travelift

Your secret paradise...

30% Discount on Slip Fees after 2nd Day!

in Nicaragua

Located in a beautiful sheltered lagoon on the north Pacific coast of Nicaragua, Marina Puesta del Sol is your premier cruising destination in Central America.

Marina Puesta del Sol RESORT

Aserradores, Nicaragua ♦ 011 (from US and Canada) 505-8880-0019
info@marinaps.com ♦ www.marinapuestadelisol.com ♦ USA 408-588-0017

It's Beautiful, It's Private, It's Home



Making boating easier – and more fun! – is what Oyster Cove is all about. That's why we rate number one with many Bay Area boaters. Oyster Cove is an exclusive yet reasonable facility of 219 berths, accommodating pleasurecraft in slips up to 60-ft long. **Oyster Cove is the private Peninsula marina closest to bluewater boating.** No other private Peninsula marina is better situated or offers nicer, fresher surroundings.

OYSTER COVE MARINA

385 OYSTER POINT BOULEVARD #8A,
SOUTH SAN FRANCISCO

(650) 952-5540

- Berths 30 feet to 60 feet
- Double Finger Concrete Slips
- Five Minutes from SFO
- Heated Dressing Rooms & Showers
- Laundry Room
- Nightly Security Patrol
- Complimentary Ice
- End Ties Available at \$5.95/Ft!

www.oystercovemarina.net

HAWAII

LONG TERM DRY STORAGE

Clear Customs at our dock

GENTRY'S KONA MARINA

HONOKOHAU HARBOR

156°1'30" W
19°40'20" N

TOLL FREE **888-458-7896**

www.gentryskonamarina.com

The friendliest boatyard in Hawaii

[weatherguy.com](http://www.weatherguy.com)

Worldwide Marine Forecasts Cruising, Racing & Commercial

Packages Starting at \$65.00 USD

(866) 882-WXGY (9949) toll free
(808) 291-WXGY (Mobile)
(808) 254-2525 (Office)
(808) 443-0889 (Fax)



970 N Kalaheo Ave
Suite C-104
Kailua, Hawaii 96734
info@weatherguy.com

www.weatherguy.com

CZZ ZARAGOZA MARINE

You always be safe with Us, over fifty years serving you

Find AB INFLATABLES
only with Us in Zaragoza Mexico.



CZZ ZARAGOZA MARINE

AUTHORIZED DISTRIBUTOR OF:



CONTACT:

2926 Francisco Medina Ascencio, Puerto Vallarta, Jalisco, México.
Phone number: (322) 22 6 32 32 - info@zaragoza.com.mx - ID: 62°13'8284
Web page: www.zaragoza.com.mx We ship to all Mexico.
Follow us on <http://facebook.com/zaragozamarine> and <http://twitter.com/zaragozamarine>

Please read before submitting ad

Classy CLASSIFIEDS

Here's What To Do:

Write your ad. Indicate category. Remember price and contact info. We make final placement determination.

Count the words. Anything with a space before and after counts as one word. We will spell-check, abbreviate, edit, as necessary.

Mail your ad with check or money order, deliver to our office; **OR, for the best - and most exposure - of your classified ad...**

Submit your ad safely online with Visa, MasterCard or AmEx at: **www.latitude38.com**

Ad will be posted online within two business days, appear in the next issue of the magazine, and remain online until the following issue is released.

PERSONAL ADS

1-40 Words.....\$40
41-80 Words.....\$65
81-120 Words....\$90
Photo.....\$30

• Personal Advertising Only •
No business or promo ads except Non-Profit, Job Op, Business Op

'Trying to Locate' Ads are for those searching for lost boats/people - not shopping - and cost **\$10 for 20 words max**

FREE Online Ads are for a private party selling a boat for less than \$1,000 - or gear totalling under \$1,000. (One per person; must list prices in ad.)

All ads will be set to fit *Latitude 38* standard • Re-Run Ads: Same price, same deadline

BUSINESS ADS

\$70 for 40 Words Max

• All promotional advertising •
1 boat per broker per issue
Logo OK, but no photos/reversals
No extra bold type • Max: 12 pt font
Artwork subject to editor approval.
Biz ads will not appear on website.

DEADLINE

is **ALWAYS** the **18th at 5 pm**

for ad to appear in the next issue.

Due to our short lead time, deadlines are very strict and include weekends & holidays.

Sorry, but...

- No ads accepted by phone
- No ads without payments
- No billing arrangements
- No verification of receipt
- We reserve the right to refuse poor quality photos or illegible ads.

Latitude 38 15 Locust Ave, Mill Valley, CA 94941 Questions? (415) 383-8200, ext 104 • class@latitude38.com

WHAT'S IN A DEADLINE? Our Classified Deadline has always been the 18th of the month, and it's still pretty much a brick wall if you want to get your ad into the magazine. But it's not so important anymore when it comes to getting exposure for your ad. With our new system, your ad gets posted to our website within a day or so of submission. Then it appears in the next issue of the magazine. So you're much better off if you submit or renew your ad early in the month. **That way your ad begins to work for you immediately.** There's no reason to wait for the last minute.

DINGHIES, LIFERAFTS AND ROWBOATS

11-FT AMI AC-330, 2006. Alameda. \$1,600/obo. Inflatable, grey, easy planing catamaran design, max 20hp removable floor boards. Good condition, used only 7 months, purchased brand new 11/08, all details on website: www.amiboats.com/boats/advanced.html. **MUST SELL.** (530) 277-8155 or cattmarine@gmail.com.

TWO BOATS, ALAMEDA, CA. \$2,500 and \$675. 16-ft traditional dory. Oak, cedar, copper rivets, bronze screws, no ply, no glass. 2 pair varnished oars, sewn leathers (motor well). Excellent condition; \$2,500. 8'4" glass dinghy with oars. Better than new. Holds 4, plus small motor; \$675. (510) 830-7982.

10-FT ACHILLES INFLATABLE, 2001. Stockton, California. \$2,500. With 2001 4-stroke 9.9 Honda. Less than 20 hours on both. (520) 850-7761 or namaste_crew@yahoo.com.

BOLGER 'DINGHY' CARTOPPER 11' 6". \$1,450/obo. Spirit sail, row or small outboard. Fiberglass over marine plywood. New condition. (530) 865-7532.

24 FEET & UNDER



14-FT SWALLOW, 2009. Santa Barbara. \$4,500. Andrew Wolstenholme design from England, professionally built in Washington State 2009, plywood and epoxy clinker construction. Gaff main, Harken roller furling jib, rigged for single-handed sailing, paddle and yoleh, cover. Complete with King road trailer and spare tires. Owner reluctantly selling for health reasons. Based in Santa Barbara. A unique and ideal family boat, which is great fun to sail. venbed@gmail.com.

24-FT MELGES. Alameda Boatyard. \$20,000. Hull #14. Race ready. Full boat covers. Contact Frank. (512) 750-5735 or cabosportsfrank@yahoo.com.

22-FT CATALINA, 1981. Davis, CA. \$1,950/obo. Swing-keel 15hp self-starting Tohatsu (just tuned). Dual batteries, Pop-Top w/curtain, 4 sails, trailer, owner disabled, some neglect. Fresh-water boat. On trailer. Best offer \$1,650-1,950. (530) 756-0874.

19-FT WEST WIGHT POTTER, 2001. Folsom Marina #B37. \$9,500. Complete package, including trailer with extension hitch, sails, sail covers, stove, Porta-Potti, cushions, 4-stroke 5hp Nissan motor, etc. Sleeps 4. Contact for complete details. (916) 409-0988 or bhuth@wavecable.com.



20-FT 'NESS' SHETLAND SAILBOAT. 2006. Sebastopol. Best offer. Handbuilt sailboat with 22' Magic Trail trailer. Balanced lug or gaff sail rig with motor well and 2.5hp 4-stroke Yamaha motor. Mahogany lapstrake epoxy resin construction. 4-6 capacity. (707) 829-8405 or jstamp@sbcglobal.net.



21-FT SEAPEARL, 1986. Tempe, AZ. \$6,000/obo. SeaPearl "ketch cat" sailboat with teak/mahogany deck, galvanized trailer, dual ballast, centerboard, antifoul paint, cushions, motormount, cover, center and captain's seat. This is a fun boat! www.marine-concepts.com. Contact Kevin (602) 821-0284, (480) 759-0318 or k-mart@cox.net.

24-FT COLUMBIA CHALLENGER, 1964. Stockton. \$3,500/obo. Price slashed \$1,000 for quick sale. Proven racer, new self-tacking/working jibs, swell main, crunchy spinnaker, smooth bottom, sink w/ice chest, pulpits, tabernacle mast, clean, rigged, sail ready. Newer trailer included. (209) 476-1381 or phil.hendrix@excite.com.

16-FT SAILING DORY, 2006. Napa, CA. \$5,600. Glued lapstrake meranti plywood construction, white oak gunwales, mahogany seats and interior finished bright. Sails great with spritsail, centerboard and rudder mounted on wineglass stern. A real attention getter. Price includes boat with sailing gear, oars, trailer and custom cover. 2hp Honda available if desired. (707) 265-8415 or roormann@vom.com.

Yacht Repair
Design / Consulting
Custom Interiors
Exterior Joinery



STEVE'S MARINE WOODWORK

60 C Libertyship Way, Sausalito
jonessail@aol.com • (415) 332-2500

N.E. MARINE TITLE

Coast Guard documentation • Title/lien searches • Transfers • Mortgage filing • Escrow services
Local closing facility for brokers or private transactions
30 years experience of doing it right the first time

1150 Ballena Blvd, Alameda, CA • (510) 521-4925



NOR-CAL COMPASS

Adjustment • Sales

Authorized Compass Repair

Hal McCormack • norcal.compass@verizon.net • Phone/Fax (415) 892-7177

BOAT • LETTERING

alphaboatsue@aol.com • (510) 599-1197 • www.alphaboatgraphics.com

Creative and durable lettering and artwork for your boat

20-FT OPEN 5.70 #189 MANIC, 2007. Redwood City Dry Boat Storage. \$24,000/obo. French built white hull, OD sails, 2 spinnakers (1 new), trailer with lights, dual rudders, depth sounder, Rockbox GPS, lifting straps, keel hoist, full waterproof boat cover, excellent shape, dry sailed, covered. Turnkey fun, fast sportboat, growing OD fleet. www.vimeo.com/14167375. (509) 637-3761 or chrismloyd@gorge.net.



20-FT SANTANA, 1972. San Diego. \$3,900. Trailer, 2.5hp O/B, 2 mains, genoa, jib and 2 spinnakers. Cushions, full cover, lifelines, stanchions, pulpit. Very clean. Race ready or overnight to the island. (760) 727-8910 or (760) 802-2034 or servpro8724@roadrunner.com.

ZEPHYR AND TRAILER WANTED. Please email. farwest33@netzero.net.



23-FT RANGER, 1976. Antioch. CA. \$3,400. Strong and FAST design perfect for Bay/Delta. Double life lines. Manual & electric bilge pumps. 30amp shore power with charger. All sails in great condition. 3 headsails, spinnaker with all gear, new UK Powerhead mainsail. Headfoil. 4 self-tailing winches. Topsides and spars repainted. Mariner 8 HP outboard runs perfectly. Dry holds, solid keelbolts, great interior. Custom cockpit cushions. Turn key! Jump on and go sailing! (925) 597-0441 or steve60ingram@yahoo.com.

20-FT PSC FLICKA, 1992. San Carlos, Mexico. \$30,000. Beautiful Flicka, single-handers package, radar, solar, Espar D2 and much more... Can deliver. Price has been reduced! Check out website and email me with questions, Randy. <http://picasaweb.google.com/sirena.jh/Dulcinea02?authkey=Gv1sRgCLWk1t-B3fXvCA#>. randy.ramirez@sbcglobal.net.

25 TO 28 FEET

26-FT LAGUNA, 1986. Redding. \$10,000. With 93 trailer, full set North sails, A-spinnaker never used, roller furling, spare sails, interior carpets and cushions plus cockpit cushions, wheel steering, remote throttle on 7.5 Honda, salon table needs rebuilding. (530) 549-4337.

27-FT PACIFIC SEACRAFT ORION. 1980. Channel Islands, CA. \$38,000 or Trade. The boat is undergoing last stages of restoration and upgrades. Sterling paint, new mast, boom, new North Sails, Yanmar 2GM20F diesel, new Raymarine electronics. Lots and lots of extras included. Finished value estimated over \$50K. Need a quick sale, as-is where-is. No owner finance but interesting trades with cash considered. (805) 701-8160 or (800) 200-8839 or ross@maritimesurveyors.com.



28-FT ISLANDER, 1984. Ventura, CA. \$21,900/obo. Nicest I-28 anywhere, this is the one you've been waiting for, 2nd owner, low-hours Yanmar, dodger/bimini, stereo, VHF, Lowrance GPS w/chip, Adler Barbour refrigeration, ST4000 autopilot, hot/cold pressure water, wheel, roller furler, spinnaker gear, outboard hoist, legal head, bottom painted 7/2009. (805) 772-7915 gregandangiew@juno.com.

26-FT MACGREGOR, 1997. \$7,900/obo. 3 sails, 1 main, 2 jibs. Includes bimini and cockpit side canvas. Rear ladder, anchor, gas stove, bathroom, sail covers and rigging. Engine 1997 8hp, 4-cycle Honda. Very low use, runs perfectly. Bottom epoxy barrier coated. The boat has always been kept on trailer. (415) 342-3181 or anne-christine@comcast.net.

26-FT ZAP, 1979. \$5,900. Bruce King called this boat, "One of my favorite designs." It's a surfin' ultralite that was so far ahead of its time, YRA made a rule change to disqualify it. Very well constructed and in excellent condition. See more: <http://zap26sail.blogspot.com>. Call (510) 277-2291.



CAL 2-27, 1977. San Mateo. \$7,900. Self-tending jib, main, spinnaker, spinnaker pole, whisker pole, new standing rigging, spreader and halyards (2009), VHF, knotmeter, depth meter, solar panel, new tiller, compass, battery and antenna, electric and manual bilge pump, ice box, new holding tank w/sea outlet, teak interior, inflatable dinghy, standing head room, great running Atomic 4, regularly maintained and ready to sail. Great family boat for Bay and Delta. (571) 236-6942 or rudder_web@web.de.

25-FT CATALINA, 1978. Chamanche. \$5,500/obo. Good condition, E-Z load trailer, drop keel, main and jib included, lazy jacks, new mainsail/tiller covers, two-year-old interior cushions with Sunbrella upholstery, pop top, anchor, fenders, folding galley dinette table, swim ladder, retracting motor mount (outboard not included), extra galley dinette cushions for fold-down bed. (209) 223-2183 or oannio@comcast.net.



27-FT ERICSON, 1978. Berkeley, CA. \$10,000. Excellent condition and consistently maintained. Great Bay and coastal cruiser. Sleeps 4. Rugged for singlehanding with all lines leading aft. Wheel with pedestal compass, lifelines and nonskid deck. Alcohol stove, sink, icebox and 20 gallon freshwater tank. New holding tank w/sea outlet. Atomic 4 in top condition. Sails include main w/2 reef points, 155 Mylar, 150 and 110 Dacron, 85% w/Harken roller. Spinn rigging. White with green deck and stripe. (925) 376-9361 or patflaharty@gmail.com.

28-FT HERRESHOFF KETCH, 1950. San Rafael. \$5,000. Proudly traditional, seaworthy craft built by Lester Ferris (original plans included). Sound wood hull, full keel, all sails, 30hp inboard, Bruce/Danforth anchors, 7' dinghy, GPS, VHF. (415) 261-3958 or woodydsailor@hotmail.com.



27-FT ERICSON, 1978. San Rafael. \$11,000. Good shape. Wheel, jib furling, diesel. Fresh bottom in March (no blisters). Recently spent \$8,000 in upgrades, all new thru hulls, dripless packing gland, muffler. Beautiful interior. Call days. (415) 265-0907 or gafalbo@comcast.net.



27-FT NOR'SEA, 1980. Moss Landing, CA. \$16,000. Tough little blue water cruiser, safe, easy to handle junk rig, many offshore mods, Fiji vet, aft cabin. Check link for pictures and detailed info at www.kabai.com/seablossom. Contact (408) 218-9604 or Kabai@yahoo.com.

27-FT ERICSON, 1972. Gas House Cove, Marina Green S.F. \$6,000. 4 Sale, partnership, trade, lease. Ericson 27 with longshaft outboard. Quiet Gas House Cove slip. Sale \$6,000, partner \$3,000 plus 1/2 slip, lease \$200 plus slip, trade 30-35 footer. Contact Peter. (707) 350-6647 or pshrive@yahoo.com.

27-FT PACIFIC SEACRAFT ORION. 1979. Alameda, CA. \$48,500. *Aphrodite* gave us great memories and adventures in Mexico. Great condition and cruise ready. Cutter rig, Yanmar diesel, Capehorn windvane, 2 Uni-Solar panels, new asymmetrical spinnaker, propane s/o, dodger, more. Surveyed July 2010. Call (530) 392-5651.

25-FT PACIFIC SEACRAFT, 1976. Marina Green. \$10,995/obo. Great bay boat, convenient Marina Green berth \$208/mo, \$1,250 transfer fee or move. Roller reefing, sleeps 5, 8hp inboard diesel. Call email pics. (530) 284-6618, (530) 284-6642 or blugoose@gmail.com.

27-FT EXPRESS, 1982. Alameda. Second owner, never raced. Excellent condition. Full sail inventory. 4hp Yamaha. Trailer. Under full boat cover since new. (510) 845-0858.

MACGREGOR 26M, 2004. \$25,000. Trailer and dinghy included. Clean Delta boat, kept in covered storage during winter. Extensive optional equipment. All lines brought aft with jib downhaul. 50hp Evinrude outboard with low hours; serviced 3/10-new water pump. Bottom paint 2008. (707) 374-5627.



27-FT ERICSON, 1976. Alameda (Ballena Marina). \$7,500. Sloop-rigged sailboat. Wheel steering with tiller attachment. Standing and running rigging in good condition. 18hp 2-cyl diesel inboard. Self-furling jib added in April 2008. (510) 205-1973 or mary_wilmot@hotmail.com.

CATALINA 250 WATER BALLAST. 1996. Stockton Sailing Club. \$12,950/obo. Roller furling (with cover), Edson pedestal steering, Boomkicker, depth and speedometer, kick up rudder, spare tiller, bimini, life vests (auto inflatable), Honda 9.9 engine, Tandem trailer with mast raising system, sail cover. (559) 479-2094 or kbernstein@gmail.com.

WOODRUM MARINE

Specializing in custom interior cabinetry, tables, cabinets, countertops, cabinsoles. For power or sail.

CARPENTRY
Mobile cabinet shop
Contact Lon Woodrum at:
415-420-5970
www.woodrummarine.com

THE BANDING KIT

A Complete Emergency Repair Kit for use on mast, boom, pole, hose and more. Recommended by the Pacific Cup Yacht Club.

Don't wait for an emergency!

415-785-3700 • www.allusa.com/banding



MikeMaurice @ YachtsDelivered.com

Power - 45 Years Experience - Sail
Expert- No. Pacific/4Seasons & Bar Crossings
China-Alaska +1-503-310-7590 - Caribbean

MARINE SURVEYS by Captain Alan Hugenot

Naval Architect • Yacht Delivery Skipper

Accredited Marine Surveyor (SAMS)

Bay or Delta • No Travel Charges • MC / VISA / AmEx
alan@captainhugenot.com • (415) 531-6172





ALPENGLLOW LIGHTS 406.889.3586

Hand Crafted, High-Efficiency Area Light
LED Swivel Reading and Berth Lights in Chrome or Titanium (Brass) Finish

Brighten your cabin with better light quality, superior color rendition, and lower battery drain! Selection of wood choices for fixtures. Splash-proof and Night-vision models available. Dual power for bright light or gentle glow, and two levels of red.



Alpenglow Lights, LLC, P. O. Box 415, Eureka, MT 59917
debi@alpenglowlights.com • www.alpenglowlights.com



Save Your Aft!

Using one of our 1900+ patterns or your own pattern, let our craftsmen create a comfortable, durable, and stylish set of all-weather cushions for your cockpit. Find your custom, closed cell foam cushions at www.bottomsiders.com!

SEE US AT THE ANNAPOLIS BOAT SHOW OCT. 7-11

BottomSiders
2305 Bay Avenue
Hoquiam, WA 98550

Call Toll Free: (800) 438-0633
cushions@bottomsiders.com
Fax: 360-533-4474

BAY MARINE SURVEY, LLC

JESSE BRODY, SAMS-AMS

- Pre-purchase and insurance condition & value surveys
- Comprehensive inspections with detailed reports
- Based in Berkeley and serving all of San Francisco Bay

 SOCIETY OF ACCREDITED MARINE SURVEYORS®

 STANDARDS 43YC ACCREDITED

WWW.BAYMARINESURVEY.COM
415.342.0757

COMPUTER ABOARD?

CAPN & Digital Charts
AIS • WiFi • Cellular Amps
SatPhones: Iridium & Globalstar
HF SSB Radio & Pactor Modems
Wireless E-mail



SEATECH SYSTEMS™
800.444.2581 • 281.334.1174
info@sea-tech.com • www.sea-tech.com
Call for Info on SeaTech Packages and CAPN Demo Disk

SEE US AT THE ANNAPOLIS BOAT SHOW



27-Ft O'DAY, 1978. San Rafael, CA. \$9,900. Great sailing boat - consistently sailed, maintained and upgraded. Clean turnkey race winner. Comfortable cruiser. Yanmar diesel. Dual AGM's, inverter, Martec folding prop. Dripless shaft seal. ProFurl AP with remote. (415) 269-3140 or windride27@gmail.com.



27-Ft CATALINA, 1977. Redondo Beach. \$9,500/obo. Completely restored. Atomic 4 inboard gas great condition! VHF, handheld GPS. NEW: mainsail, jib furling, all paint, compass, depth sounder, lots more. Please email me for full list and more photos! (818) 726-5098 or pascalenyby@gmail.com.

27-Ft CATALINA, 1978. Berkeley. \$5,900/obo. Joy. Unique w/custom portholes, roller furling. Ready to sail, upgraded chainplates, recently tuned rig. Running Atomic 4. Huge owner network. Coastal cruiser. Liveboard ready. Transferable slip. www.flickr.com/photos/53701147@N07/. (310) 903-9501 or lobster@brindze.com.

29 TO 31 FEET



28-Ft HAWKFARM, 1976. Alameda. \$16,000/offer. Eclipse. Excellent condition. Immaculately maintained by original owner. Fully equipped. Ready to race or cruise. Bay or Ocean. Storied racing career, comfortable cruiser. New Yanmar inboard diesel. Many sails. Electronic package. Many extras. (510) 522-4006 or fredric.hoffman@gmail.com.



29-Ft PEARSON TRITON, 1966. Redwood City. \$5,000/obo. Turnkey-ready, well-maintained classic offshore cruiser. Raced on 7/17/2010, placing 2nd out of 7 Tritons in the annual BVBC Plastic Classic. Photos on Craig's List. Bought bigger boat, must sell. See more at <http://sfbay.craigslist.org/boa/>. (650) 780-9914 or chuckmillar@gmail.com.

25-Ft MERIT, 1974. Richmond Yacht Club. \$3,500. New standing and running rigging. New bottom paint. 2002 Honda 5hp outboard long shaft. (925) 462-8257 or (510) 610-8879 or glenn.davis40@comcast.net.

31-Ft HUNTER, 1984. Ballena Isle Marina, Alameda, CA. \$25,000. Very good condition. Full dodger, roller furler, Quest 150 custom genoa, spinnaker pole, Raymarine radar/chartplotter and autopilot, cockpit table, Yanmar diesel, VHF radio, CD with 6 speakers, low wattage inverters, (2) new batteries, 2009 bottom paint, H/C pressurized water, (2) burner stove with oven, BBQ, inflatable mini-dinghy, self climbing Top Climber. All Coast Guard required safety equipment, charts and books, (2) anchors and rodes, Buoy hook. Too much more to list. (775) 626-2679 or (775) 722-1600 or pcscarli@aol.com.

25-Ft CATALINA 250 WATER BALLAST. 1995. Benicia. \$17,988. With trailer and mast raising system. 8hp Honda 4-stroke long shaft, all new navy blue canvas, snorkel, wheel cover, carpets, etc. Wheel w/pedestal. Boat is immaculate. Will not disappoint. Very hard to find. (707) 696-9600 or cogswell1777@yahoo.com.



CATALINA 30 MK I, 1979. Rio Vista. \$8,900. Tiller, Atomic 4 good runner, recent 110 genoa w/roller furling, interior woodwork in very good shape. (559) 284-2144 or oblomenow@gmail.com.



Repair, Restoration & New Construction
Fred Andersen Boat & Woodworks (510) 522-2705

STARBOARD YACHT DELIVERIES

Over 50,000 sea miles • Pacific, Caribbean, Atlantic
USCG Master 100 GT STCW • Power & Sail

Rick Whiting • (415) 740-2924 • captain_rick@sbcglobal.net

29-FT ERICSON, 1972. S.F. Marina. \$16,500. Immaculate ocean cruiser/racer. Optional slip. Inboard Atomic-4, galley, head, sleeps 6. Roller furling headsail. Easy singlehand. All new: main, genoa, standing and running rigging, whisker pole, radio, mast antenna, charger, more. Racing setup. (415) 658-1826 or ewilliams924@yahoo.com.

30-FT MORGAN, 1970. Berkeley. \$9,300. 24hp Universal diesel, feathering propeller, tiller. Standing, most running rigging replaced 4 years ago. Lifelines 2 years, new bottom this August, 3 headsails, drifter, newer main. 6'2" headroom, dinette. (510) 490-5500 or (510) 366-5449 or mpainter@comcast.net.



30-FT CONTEST, 1970. Stockton, CA. \$6,800. Built in Holland. Heavy duty trailer. New bottom job. Two sets of sails. One tan bark set unused. New spinnaker and storm main and jib. Nice mahogany interior. Busted but complete A4 is on trailer. Email for pics/info. (530) 355-1338 or bobe@cwo.com.

30-FT PEARSON, DELTA. \$7,800. Price reduced. NEW bottom last May. 2002 model Volvo diesel, cabin heater, clean and ready. Call for info. If you have called before, I was out of town. Please call again. (916) 777-5510 or (916) 217-6908 or chardonnaymoon@att.net.



29-FT CAL, 1972. Novato. \$12,500. Newly painted hull by pro. Atomic 4 runs great. Spinnaker, radial headsail (shown). 3 jibs (90,110,150), 7 winches, 2 mainsails - all VG condition. Autopilot, 12V refrigerator, whisker pole, battery charger. (415) 883-5365 or lagoonlovers@sbcglobal.net.

30-FT CATALINA, 1976. Paradise Cay, Tiburon. \$17,900. Universal Atomic 4 gas engine and transmission, completely rebuilt by Jacobson machine. Self-furling jib, rigged for spinnaker. Surveyed, bottom cleaned and painted Aug 2007. New propeller shaft, bearings, fathometer, exhaust system, hoses and bilge pump. (Possible partnership). (415) 342-3181 or anne-christine@comcast.net.

30-FT CS, 1985. Vallejo Yacht Club. \$29,000. Top quality Canadian-built family cruiser. Well maintained, full sail inventory, new Pineapple jib, reliable V-P diesel, extremely roomy 6'2" headroom. Working overseas - no time to sail! See website for full details: <http://avocet.weebly.com>. (530) 389-4308 or svavocet@gmail.com.



J/29, 1985, SEATTLE. \$18,500. Great race record, masthead rig, hydraulic backstay, B&G, stereo, rod rigging. Restored in 2002. Will take J/24 on trade. (253) 288-0117 or mandmstudios@q.com.

30-FT BABA CUTTER, 1981. Antofagasta, Chile. \$54,000. Roller furler, genoa, stormsails, drifter with sock, extensive ground tackle, Yanmar 30 with good spare inventory. Inflatable with 2hp Honda outboard. Delivery negotiable. (907) 299-1068 or jemkob@hotmail.com.

ISLANDER 30 MK II, 1971. Moss Landing Harbor District. \$7,500. 4-cyl gas inboard (Palmer P60). Fiberglass hull w/ teak trim. 3-burner alcohol stove/oven, BBQ. Depth/fishfinder, CB and VHF radio. Recent work: Sept '09 hauled out, tuned up, oil change, new head, replaced through hulls and zincs. Sails include spinnaker, 2 storm jibs, 100% & 130% genoa. Mahogany interior. 5 lifejackets, lots of extras. Sleeps 4 comfortably. Good solid boat. Ready to sail. Take over slip. (831) 915-6783 or (831) 659-1921 or drbradcase@sbcglobal.net.



30-FT SANTANA 3030PC, 1982. Ventura. \$27,000. Race or cruise. 2-cyl Yanmar 267hrs. New headliner/cabin sole/electrical panels. New rod rigging. Harken traveler/genoa leads. Harken roller furler, dodger, H/C pressure shower, CNG stove/oven. Full sail inventory. Too much to list. (805) 581-9220 or dnclaws@aol.com.

30-FT SEIDELMANN 299, 1979. Pelican Harbor, California. \$37,000. MUST SELL. 135mph speed, fin keel, accommodations, modulations, fishfinder, knotmeter. Slip available to qualified buyer.

SOLD

30-FT ISLANDER BAHAMA, 1981. Fortman Marina, Alameda. \$16,000/obo. GPS, dodger, wheel steering, furling jib, ext sails. Strong diesel engine. Clean boat. Owner getting old, need to sell. Please call or email. (209) 984-2085 or bkseeker@sbcglobal.net.

32 TO 35 FEET



32-FT VALIANT, 1980. San Francisco. \$45,000. Proven bluewater cruiser, roller furling jib, 3-cylinder Universal diesel, windvane, radar, autopilot, SSB and VHF radios, anchor winch and all-chain rode. Hot water, shower, propane stove w/ oven. 6-man liferaft. (415) 601-5666 or ken@keltonconstruction.com.

34-FT SAN JUAN, 1984. \$30,000. Price reduced for quick sale. Fast comfortable, blue water cruiser, excellent condition. 6' headroom, galley, sleeps six, rod rigging. Roller furling headsail, 150% genoa, main, working jib. 3GMD Yanmar, Achilles dinghy, large bimini. Original owner. (510) 420-8956 or nino@access-print.com.



35-FT YOUNG SUN CUTTER, 1981. San Carlos, Mexico. \$74,800. Blue water cruiser, located in San Carlos, Mexico, ready to sail the world, full cruise equipped, more information on our website, or email. <http://youngsun.squarespace.com/specs>. (970) 259-5102 or mohrmonte@gmail.com.

34-FT CATALINA, 1987. Monterey. Popular 34-footer in very good condition. Sale by moving owner. Ready to sail, standard rig, roller-furling, spacious and clean interior, draft 5'7", lots of instruments, autopilot, well maintained diesel engine. Priced for quick sale. For more details, email sailcata34@gmail.com.

35-FT ERICSON, 1974. Downtown Sausalito. \$31,500. Upwind slip with view of Angel Island from the cockpit, forest green canvas, dodger, roller furling, gennaker, D.S., K.M., VHF, GPS, Yanmar diesel-950 hrs. A very pretty boat. (707) 357-1309.

32-FT CATALINA C320, 2004. Dana Point Harbor. \$98,750. 100 hours, excellent condition, Collinite detail, new bottom paint, 2 new batteries, professionally rebedded, adjusted rigging, modified pulpit and roller fits 30-ft slip (32' LOA). Owned since new, photos on request, extras. (949) 842-1032 or jnaki@cox.net.

32-FT SABRE, 1985. Sausalito Yacht Harbor. \$51,500. Replaced/new '09: all cushions, propane stove/oven, GPS, VHF, stereo, batteries, all hoses, jib, steering cables, running rigging and engine heat exchanger. Westerbeke 21hp diesel. Canvas dodger. Avon 9-ft dinghy. manukai41@yahoo.com.

34-FT HUNTER 33.5T, 1991. Point Richmond, CA. \$35,000. For sale by original owners; impeccably maintained. Full-battened main w/Dutchman flaking system, roller furling jib, autopilot, 27hp Yanmar, inflatable dinghy with outboard included. Photos and additional information at website: <http://ssmay2.blogspot.com>. ssmay@mindspring.com.



34-FT TIFFANY JAYNE, 1983. Richmond YC. \$39,500. Perfect for SF Bay and beyond. Beautiful, fast (PHRF132) and responsive. Delightful to sail. In the spirit of the Alerion for 1/3 the price. One owner. Superb condition. <http://sites.google.com/site/tiffanyjaneforsale/>. (510) 525-0279 or rpackard@berkeley.edu.



34-FT J/105, 1994. San Francisco. \$82,500. Hull #83, pre-scrimp boat is for sale. Lightly used. Minimum class weight, wheel package, excellent condition. (650) 380-1583 or josephandresen@mac.com.

32-FT ISLANDER, 1976. SF Pier 39, Slip C-26. \$9,500/obo. Extensive work on rigging, engine, and hull in 2005. Last 3 years neglected due to illness. Interior good condition. Exterior needs TLC. Same owner since 1998. Must see to appreciate. To be sold as is. (831) 624-4910 or ted@twjohnston.com.



superwind.com



THIS COULD BE YOU...

Let the Classy Classified business ads work for you.

Submit online at:

www.latitude38.com

Ted's Marine Refrigeration

Available November-May: Guaymas, San Carlos & Sonora, Mexico
10 years experience, Mexico/US • New Systems, Design, Troubleshooting • Refit & Retrofit Icebox
Construction • AC/DC Engine Drive, Holding Plates, Environmentally Friendly Refrigerants
EPA Certified Since '96 ☆ a290anna@gmail.com ☆ (408) 656-0549

MARINE SURVEYOR

Sharpe Surveying & Consulting. SAMS Accredited Marine Surveyor.
Serving the San Francisco Bay and Delta.

RSharpe@SharpeSurveying.com • (510) 337-0706

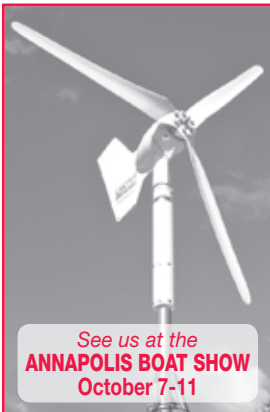

MORE ENERGY!

KEEP BATTERIES CHARGED!

- KISS wind generators
- Solar panels and MORE

USE BATTERIES EFFICIENTLY!

- LED lights
- Engel fridge/freezers
- Wonder Wash and more



See us at the
ANNAPOLIS BOAT SHOW
October 7-11

www.svhotwire.com

727.943.0424

Marine Diesel Specialists AT YOUR SLIP!



30 years experience • Universal/Westerbeke dealers
Repairs/Tune-ups all models • Engine Surveys, Instruction

BAY MARINE DIESEL

510-435-8870

baymarinediesel@comcast.net

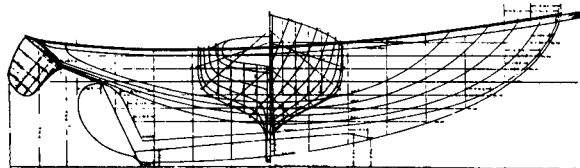

MAKELA BOATWORKS

Family owned since 1948

Wooden Boat Building • Repair and Restoration

19280 South Harbor Drive • Fort Bragg, CA 95437

(707) 964-3963

email: howard@makelaboatworks.com • www.Makelaboatworks.com

FAST SHIPPING!

NEW AND USED SAILS!

Specializing in production boats and featuring the largest selection of stock sails available anywhere! Save with warehouse volume discounts on Stock Sails, Custom Sails, Sail Covers, Furlers and Accessories. All top Quality.

All Fully Guaranteed!

- Full Batten Mains
- Furling Genoa's
- Storm Jibs
- Trysails
- Furling Units
- Custom Canvas
- Used Sails



THE SAIL WAREHOUSE

VISA **MasterCard**

Ph. (831) 646-5346 www.thesailwarehouse.com



33-FT HANS CHRISTIAN, 1980. San Diego. \$119,000. Change of plans! Fully refitted for S. Pacific voyage. New Yanmar, electronics, watermaker, sails, rigging, batteries, solar, canvas, dinghy and spares. Loads of cruising gear. Ready to go. (619) 319-0136.



34-FT PEARSON, 1984. Wilmington. \$41,250. Original owner. Fin keel. Great condition with 110 genoa and blade storm jib. Autopilot, propane stove/oven, wheel steering, battery charger, H&C pressure water, must see, 20 hp original Yanmar diesel engine. pinkclan4@comcast.net.

34-FT HUNTER, 1984. Sausalito, CA. \$24,900. If you can find a cruise-ready sailboat at this price, take it! This is a 34-ft sailboat that could leave for Mexico tomorrow. Just fill up the water and fuel and turn left after leaving the Golden Gate. Any takers? This is an excellent, first time boat that is rigged for singlehanded and operates well under all conditions. I love this boat, but I am now the owner of another boat, so it is time to sell. This Hunter is priced to move. Photos and a detailed description of the boat can be found at: <http://witchdoctorsailboat.webs.com>. (415) 497-6116 or medicrene@yahoo.com.

36 TO 39 FEET



36-FT ALLIED PRINCESS, 1977. San Rafael, CA. \$40,000. This well regarded cruising ketch has undergone a major refit over the last five years, including new rigging, electronics, sails, and hull LP paint. The boat has had three owners, and all maintenance documents, including original delivery manuals are onboard. (707) 364-0801 or rkhut@comcast.net.



35-FT COOPER 353, 1981. San Diego. \$64,900. Roomy, solid coastal cruiser. Excellent condition with many improvements. New engine, batteries, wind generator, nav equipment. Good looking boat inside and out. Divorce sale. See details and pictures at: <http://picasaweb.google.com/114099174294335707289/Cooper353#>. (928) 699-0986.

37-FT GULFSTAR, 1978. Berkeley Marina. \$27,500. Great boat to sail, roomy, comfortable and very stable. Extensive rehab in 2002, new standing and running rigging, thru-hull fittings, roller furling, head and holding tank and more. (619) 244-2144 or jimhumphrey@cox.net.



32-FT ERICSON, 1971. Bruno's Island, Isleton. \$18,900. Great cruising and Bay boat. Well maintained, excellent mahogany interior, new bottom paint. Three headsails, spinnaker, lines led back, self-tailing winches, Yanmar diesel, LectraSan sanitation, depth sounder, knotmeter. (510) 207-0111 or (510) 525-3572 or don@dondommer.com.



39-FT CAL, 1980. Berkeley. \$59,000. Great Bay and Delta boat. Lots of upgrades completed in the last 12 months. Terrific sailing qualities and offshore capable. Maintenance records and photos available, Perkins 4-108 with wide range of sails. (916) 208-3606 or gary.greule@gmail.com.



OFFSHORE PASSAGEMAKING INSTRUCTION IN THE SOUTH PACIFIC

John & Amanda Neal are dedicated to providing hands-on, documented instruction aboard their Hallberg-Rassy 46 *Mahina Tiare III*, drawing on their combined 502,000 miles and 66 years of experience.

www.mahina.com • (360) 378-6131

Going Somewhere? **Mexico • Caribbean • South Pacific**

Stop by our office and take a bundle of *Latitude 38* along with you.

We promise you'll be a hero for sharing them with other cruisers!

Latitude 38 • 15 Locust Ave • Mill Valley, CA • (415) 383-8200 • Open M-F 9-5



38-FT CAT KETCH, \$49,000, ASKING. This easily handled Halsey Herreshof-designed Cat Ketch 38 has unstayed carbon fiber masts: no standing rigging to worry about, no foresails to contend with. She averaged 7-8 knots from Puerto Vallarta to Napa. The hull is of sandwich construction with Airex closed-cell foam. The Caribbean pine interior features two private cabins, each with a head (one of which has a composting toilet). She is well equipped with radar, autopilot, watermaker, ultraviolet water purifier, fuel system algae remover, new Awlgrip paint and brand new sails. (707) 254-0220.

38-FT HUGHES, 1970. Monterey, CA. \$21,000/make offer. Canadian built S&S design. Sound hull, low hours on nearly new diesel engine. Sails nicely, needs TLC & newer/upgraded equipment. (831) 915-4984 or coffina@sbcglobal.net.

37-FT TARTAN, 1976. Maryland. \$34,000. Bahamas, Caribbean? Budget cruiser, go now. Good old boat. New Harken furler, radar, SSB, solar, '08 FB main, windlass, AP, frig, inverter. Centerboard missing, sweet sailing S&S design. If not now, when? (301) 974-2620 or tw33432@yahoo.com.



38-FT ALAJUELA, 1976. Sequim, Washington. \$129,000. Well maintained and equipped 38-ft FRP cutter. Stoutly built for offshore cruising. Many improvements including new engine 2005. Go to blogspot for full details and photos: <http://alajuela38.blogspot.com>. (360) 683-8662 or svselah@yahoo.com.

37-FT CREALOCK CUTTER, 1980. Monterey. \$45,000. Ballenger tabernacled mast. New Yanmar w/saildrive, radar, GPS, easy access to all systems, 70gal diesel, 3 watertight bulkheads. Not in yacht condition, needs finish work. Great little sailing ship. Price firm. Email ddatpbio@gmail.com.



38-FT KETTENBURG, 1956. 3 Available. "Nice boat!", "Beautiful boat!", "Gorgeous boat!" heard many times from other boaters during every sail. Enjoy character, admiration, and fantastic sailing while sustaining the heritage. More details at: www.saik38.com. (916) 847-9064 or steve@paradigmpilgrim.com.

36-FT HUNTER 356, 2003. Alameda. \$92,900. Beautiful boat. Very spacious interior. New bottom paint. Save thousands over buying through a brokerage. See all details and photos on the listed web page. <http://web.mac.com/laynegalloway>. (801) 419-4100 or laynegalloway@msn.com.



HANS CHRISTIAN 38 MK II, 1985. Savannah, Georgia. \$80,000 motivated. Price lowered!! New epoxy glass hull, shaft, MaxProp, cutlass and stuffing box, 300' of 3/8 HT chain primary, 100' 3/8 HT on 300' rode secondary ground tackle from Svendsen's Aug. '09, new keel-cooled Frigoboat unit, new Lectra-Scan. Raymarine radar and chartplotter. Two mains-one full batten, 130 jib, staysail, storm sail, inner forestay blooper sail. Ready for Med or Fiji. (404) 354-3855, (770) 710-7079 or joe_millsaps@yahoo.com.



38-FT HUNTER 380, 2001. San Diego, CA. \$119,000. Well loved Hunter 380 for sale by owner. Lots of equipment and extras... ready to go! Go to her website for pics and full specs: www.hunter380.com, or call us and we will fax or email them to you. (909) 721-2095 or (909) 721-0891 or dcafr2@yahoo.com.

37-FT ALBERG, 1980. Port Townsend. \$60,000. Excellent condition, well maintained. Lots of sails. Profurl roller furling, Volvo diesel, windlass, monitor and Autohelm self-steering, GPS, VHF and sideband radios. Bruce anchor, 200' chain dinghy and outboard, recent survey. Contact James. (360) 765-3222 or jarsulich@olympus.net.

39-FT FREYA IN STEEL, 1974. Oxnard, CA. \$35,000/obo. Freya Halvorsen 39 steel sloop. Insulated, rebuilt 85hp Ford diesel. Autopilot, radar, GPS, fridge, shower, hot water. Hood roller furling, hydraulic windlass, sounder, dodger, refurbished aluminum mast/boom. 8-ft dinghy. (805) 200-6089 or traim69@hotmail.com.

37-FT PEARSON INVICTA YAWL, 1967. Oakland, CA. \$25,000. Monitor vane, solar panels, hard dodger, windlass, heavy anchors, roller furling, recent bottom, new propane stove, heater, chart plotter, charger, stereo. Needs Westerbeke diesel installed, new hatch secured. Ready for cruising. (707) 758-4417 or trilightsailor@gmail.com.

39-FT SWAN 391, 1986. Puerto Vallarta, Mexico. \$149,000. 39'10" LOA, designed by Ron Holland. Excellent condition with low engine hours. Major refit 2007-2010 with new standing & running rigging, batteries & charging, windlass, etc. VHF, SSB, W/Fx, B&G instruments. Email ilalovic@hotmail.com.

40 TO 50 FEET



43-FT 435 BENETEAU, 1985. Marina del Rey. \$129,000. A rare pedigree French export. Open checkbook refit and maintenance. Huge equipment list. Tall rig. 12 ST Lewmar's, Harken, low-time Perkins, all B&G's w/pilot, custom panel, Furuno radar/GPS. Perfect teak decks. Huge aft stateroom. Navtec and Quantum, etc. Swan looks-Frers speed. Sistership in book "World's Best Sailboats". Timeless beauty. Turnkey. (310) 666-4546 or (310) 550-0742 or berniefried@gmail.com.

40-FT HUNTER LEGEND, 1986. La Paz, MX. \$68,000. Cruise ready for the 2010/11 season, full electronics, comfortable performance cruiser. Constantly upgraded with newer equipment. Call or write for details and pictures. Save money by buying in Mexico. (530) 957-2810 or gregondetente@gmail.com.



45-FT SPARKMAN & STEPHENS. Seafarer Yawl, 1962. San Francisco. \$75,000. Yacht *Soltura*. Built in Holland in 1962 of hand-laid fiberglass. Seven Seafarer 45's were built, and their high quality of construction is evident. Great size for the Bay, Delta and Pacific. Sea-kindly and easily handled by two people. Contact Jerry. (415) 435-3513 or gsrusemy@yahoo.com.



40-FT PETERSON IOR, 1979. Singlar Marina, Guaymas, Mexico. \$90,000. Alum. hull, Pathfinder 50, watermaker, electric windlass, 66 Bruce, Profurl, hard vang, spinnaker/whisker poles, full batten 3 reef main, Strong Track, 5 headsails, boom brake, winches-2 3-speed, 5 self tailing, radar, GPS, depth sounder, autopilot, windvane, 2 solar panels, 100 amp alternator, 8 AGM, 2 inverters, stove/oven, Lavac head, refrigerator-7.2 cubic ft. (435) 513-1556 or s.blues1@yahoo.com.

46-FT PETERSON CUTTER, 1981. \$165,000. Change of plans. Ready to cruise, everything new! MaxProp and shaft, Xantrex inverter. All Raymarine electronics, autopilot, Furuno radar, water and fuel tanks, Lofrans, cruising Mylar main+135%. Spin & sock, Furlex, Awlgrip hull and deck. (805) 469-3014.



43-FT ROBERTS 434. Corten Steel Pilothouse, 1997. Tomales Bay. \$75,000. Serious offshore cruiser ready to go. Corten steel, modern underbody, Yanmar 75 turbo 350hrs, radar, watermaker, 640w solar, Lofrans windlass, good sails with cockpit sail handling. See more at <http://sites.google.com/site/svfunkadelic/>. Email svfunkadelic@gmail.com.



SMALL AD, SMALL PRICES • RIGGING ONLY

Standing and running rigging, life lines, furling gear, winches, line, windlasses, travelers, wire and terminals, blocks, vangs, and much more.

~ ~ ~ Problem solving and discount mail order are our specialties ~ ~ ~
www.riggingonly.com • (508) 992-0434 • email: sail@riggingonly.com

Need Crew? Latitude 38 Crew List A Boat to Crew on?

Visit our website and sign up as Skipper or Crew • It's Free

Find out about our next Crew Party at:

www.latitude38.com/crewlist/Crew.html or call (415) 383-8200



PROFESSIONAL DELIVERY CAPTAINS

San Diego based, USCG Master 100 GT. Sail and power.

ASA-certified instructional deliveries. Pacific Mexico and Baja Bash specialists.

davidhbrotherton@yahoo.com • www.boatdeliverycaptain.org
 • (619) 913-7834 •

COMPLETE MARINE WOODWORK

Design / Restoration • Expert European Craftsmanship • Interior / Exterior
 Repairs / Maintenance • Marine Windows & Frame Replacement
 Wood & Dry Rot Repairs • Varnish Work • Marine Painting
 References Available • Reasonable Rates • Call (415) 331-6718

Mathiesen Marine

For all of your electronics and electrical needs

End of Season Sale - Lowest prices of the year on all brands of electronics!

Raymarine Mobile Showroom on site
Saturday & Sunday, October 16th & 17th



3300 Powell Street, Emeryville

(510) 350-6622 www.MathiesenMarine.com



Donate your Boat

Cars, Trucks, RVs, & Real Estate

We handle all DMV & Smog
Running or Not

Tax Deduction

BLUEWATER NETWORK | **800-324-7432**

"Proceeds help **Bluewater Network** reduce greenhouse gases, clean up our air and water, and protect marine mammals and wildlife."

We are always
looking out for you!

American Yacht Insurance for boats over
26 feet. We provide cover for any flag
registration or
navigation.



PANTAENIUS
American Yacht Insurance

Germany • Great Britain • Monaco
Denmark • Austria • Spain • Croatia
Sweden • USA*

500 Mamaroneck Avenue Suite 318
Harrison, NY 10528
Phone (914) 381-2066

Newport Shipyard
One Washington Street
Newport, RI 02840
Phone (401) 619-1499

www.pantaenius.com

*Pantaenius America Ltd. is a licensed insurance agent licensed in all 50 states. It is an independent corporation incorporated under the laws of New York and is a separate and distinct entity from any entity of the Pantaenius Group.

WEDLOCK, RAMSAY & WHITING Marine Surveyors

Vessel surveys,
consulting, deliveries.

Serving the
Bay Area
since 1980



www.norcalmarinesurveyors.com

(415) 505-3494

44-FT KELLY PETERSON, 1977. Kemer/Antalya Turkey. \$90,000.00. Fully loaded/ready for cruising. Perkins 4236/1993 90hp engine rebuilt 2009. 5 sails including beautiful chute. In process of installing Raymarine HD radar. PUR watermaker, solar panels, KISS wind generator, 2009 AGM batteries, much, much more. Located on the beautiful Turquoise Coast at Kemer/Antalya, Turkey. See marina website: www.Kemerturkizmarina.com. Will be on board October/November. Rent paid to May 2011. jking38701@aol.com.

41-FT MORGAN CLASSIC MODEL. 1991. San Carlos, Mexico. \$98,000. Primo condition. Equipped and ready to cruise. Center cockpit, great liveaboard, must see to appreciate roominess. Recent survey. See blog for equipment list and current photos, <http://sailboatvagari.blogspot.com>. Contact (520) 825-7551 or stanstreb@gmail.com.



44-FT CATALINA MORGAN 440, 2005. Napa. \$220,000. In great condition. Completely set up for cruising and has sailed to Tahiti and back. Roller furling, inner forestay, autopilot, radar, chartplotter, dodger, 120 Vac inverter, 600 AH battery bank with quick charge system, 75hp diesel engine, VHF, stereo, 2 zone cabin HVAC, refrigerator and freezer, watermaker, dinghy davits, 4 sails including asymmetrical spinnaker. Call Denny for more details. (707) 486-0412.

J/41, 1985 SPINDETT MARINA. Isleton. \$210,000. Race, V-berth, interior, refrigerator, radar, 2 auto and 2 years in Mexico.



40-FT FORMOSA KETCH, 1975. Marina Bay, Richmond. \$25,000. 40ft O.A., 34ft O.D. Glass hull. Partially rebuilt 2001-present. Replaced items with new includes engine, masts, electrical, electronics, etc. Excellent liveaboard. Complete inventory. (415) 302-9944 or mpayne@camarin.org.

45-FT DOWNEASTER CC, 1980. La Paz, Mexico. \$Best offer. This California-built boat was refit in 2004. Our plans have changed and we will make this an excellent deal for new owner. Can be seen at website: www.mazmarine.com. (941) 204-3271 or kruzn2004@aol.com.



GULFSTAR 43 MK II. center cockpit ketch, 1979. San Diego Pier 32. \$89,000. Much loved ketch, easily handled by two. Great liveaboard with 2 cabin, 2 head layout, great galley. Perkins 4-108. Continually maintained. Ready for cruising, just add electronics and go. See detailed specifications and photos at www.svDreamKetcher.com. (805) 558-9969 or skipper@svDreamKetcher.com.



50-FT HERRESHOFF CARIBBEAN. 1978. Napa Marine. \$199,500. 14.5' beam, 6' draft, Perkins 6-354, radar/AP/SSB-Ham, VHF, Probe, 6-person raft, spares, tools, dinghy/motor. Fresh interior refinish. Not a fire sale. Serious inquiries only. www.sailboatlistings.com. Call (707) 834-4798.

50-FT FD-12, 1981. Mexico. Unsinkable 50-ft cutter, AK/Mexico/SoPac vet. Superb galley in pilothouse: generous counter space, good daylight and view. Berths for 5-6 in 2 staterooms forward and master stateroom aft (privacy for parents w/children or guests). More at www.svdaydreamer.com. Call (928) 717-8812.

40-FT DELPHIA GT TALL RIG 2 CABIN. 2008. Sausalito, CA. \$268,000. Rare combination of high performance sailing AND hand crafted old-world mahogany interior. Built tough for the Baltic; built beautifully for comfort and sophisticated tastes, this import is LOADED. Dealer demo with ocean coastal shakedown and SF Bay demo sails the only mileage. PRACTICALLY NEW. Serious inquiries only, this boat MUST be seen. Full specs and pictures on dedicated website: <http://delphia40gt.info>. Leave contact info or call John at (415) 332-5209.

INTERNET FRAUD. Recently, we've been getting more reports of a new twist in Internet scams, so we feel compelled to warn you once again about this unfortunate aspect of human nature. The newest scam is for someone to give you a check for \$2,500 over the asking price, (or a deposit), to cover test drive fees, inspection or delivery costs. They have transporters available. Then they will ask you to cash the check and pay the transporters or drivers, keeping your cut. Then, much later, the bank informs you that the check was no good. You will be out the \$2,500. We recommend that you don't even respond to the initial email inquiry. For more info on these cons, see: www.craigslist.com/about/scams.html. Brave New World.





41-FT BENETEAU OCEANIS 411, 2001. Mediterranean. \$139,000. The perfect couple's cruising boat with offshore capabilities. Two cabin owner's version. Designed by Groupe Finot and built by Beneteau in France. Well-equipped and meticulously maintained. Never chartered. Stored on the hard at least six months per year since new. Only 1,100 hours on Volvo 59hp engine. No sales tax, personal property tax, or value added tax for USA buyers. USCG Registered. Lying in the Med. (415) 269-4901 or sail@voleauvent.com.

48-FT ISLANDER, 1985. Sausalito. \$185,000. This is a classic Ted Brewer design built by Islander. Pristine condition, 3-year renovation just completed. Just about everything is new, sails, rigging, plumbing, pumps, etc. Call or email for all the information. (415) 846-6919 or sailonbaby@gmail.com.

40-FT HANS CHRISTIAN CHRISTINA, 1988. Peninsula. \$125,000. Modern design, light teak interior, Pullman berth and aft stateroom, Cape Horn self-steering, self-tailing winches, sails beautifully. Plans changed, not using it very much. Contact via email or leave message on phone. HCchristina40@gmail.com or (650) 563-5686.

51 FEET & OVER



65-FT FREEDOM, 1981. Berkeley Marina, L. Dock. \$65,000. Fiberglass/balsa core, 200hp Volvo Penta diesel, about 100hr. 3-carbon fiber mast, sail plan not finished, bottom kept up - in good shape, boat needs work. This is one big boat! 18-ft beam, lots of headroom. Contact (510) 701-5846 or ronwmail@yahoo.com.



51-FT STEEL KETCH. Super world cruiser, Ventura. \$119,900. 51' overall, 44' on deck, 40' at water line, beam 12'11", draft 5'10". Ford Lehman, 80hp diesel engines with low hours. *Felicity* has radar, AP, dodger, inverter, furling jib and genoa, Bristol condition paint and varnish, mahogany interior with many other features. Built in Holland with the finest quality of steel construction, and has been professionally maintained by her owners for the past 25 years. This is a stout, well-built offshore cruiser. She has a draft of less than six feet and 250 gallons of fresh water capacity. Email for more information and pictures. Market value: \$165,000. Now: \$119,900. Replacement cost exceeds 1 million dollars. (805) 290-6119 or (805) 650-8888 ext: 133 or dennis@survivalsystems.com.



55-FT FIBER STEEL, 1980. River View Marina, Sacramento \$Make offer/Must sell. 72' LOA, 16' beam, F/C, 671 main engine with 300 hrs. 15KW gen, 1100 gals. diesel, 500 gals. fresh water, ketch rig. New sails, 6'6" head room, sleeps 8. Dinghy and new electronics, 385' 3/8 ht chain, 2000 lb windlass, 2 heads, shower, ice maker, 2 refrigerators/freezers. Great liveaboard with liveaboard slip. 7 minutes to downtown Sacto. Possible trades? Health forces sale. (916) 208-4141 or seahawk2mexico@gmail.com.

CLASSIC BOATS

27-FT SEA ISLANDER, 1954. Alameda. \$12,000. 32 ft. overall, sloop rig, mahogany on oak, bronze fastenings, new diesel engine, 90% new oversized standing and running rigging. Professionally and lovingly maintained. Serious inquiries only. (925) 933-4252 or (510) 506-8578 or sandrabackovich@sbcglobal.net.

MULTIHULLS

42-FT KURT HUGHES CRUISING CAT. \$10,000/obo. Both hulls are about 65% complete, but unfinished. The builder ran out of time and money. Hulls have been turned. Includes the plans. (805) 461-0434 or (805) 235-7937 or michaelcurtis7982@sbcglobal.net.



32-FT PDQ, 1997. SFYC. \$129,900. Price reduced. Absolutely Bristol. Survey/refit 2009. New sails, batteries (5), dodger, engines (100hrs). Two 135W solar panels. Raymarine plotter/radar/tridata instrumentation. Spinnaker. Central heat/AC, microwave/instant hot water/frig. Bose sound system with flat TV and more. Must see. Replacement value 200k. (415) 497-1350.

50-FT PRIVILEGE 495, 2002. San Diego. \$680,000. French built Privilege 495. Great condition, ready to sail. In San Diego in October. See more at <http://catamarankertidou.blogspot.com>. (619) 208-9985 or thierrybonnefille@yahoo.fr.

45-FT CASAMANCE, 1988. San Carlos, Mexico. \$195,000. Fantastic Fountain Pajot catamaran proven blue water cruiser. 3 staterooms plus tool room. Roller furling main and headsails. Diesel generator, 160 amp alternator and 24 GPH watermaker. Email for photos, additional information. (209) 743-6275 or (209) 694-4609 or vik@inreach.com.



34-FT CROSS TRIMARAN, 1980. La Paz, Baja California. \$10,000. This Cross 34 Trimaran lost its mast 2 months ago; it is now stored out of the water at Marina Singlar in La Paz. It has dagger boards, kickup rudder, retractable bow sprit, watermaker, radar, dinghy, wind generator, great sails and much cruising equipment. It needs a new mast (3-5 available in La Paz) and work to fix cracks in the deck. (619) 992-8496 or trimarandan@hotmail.com.

31-FT CORSAIR F31, 1995. Ventura. \$84,000. Aft cabin F31 set up for singlehanded sailing. Factory modified transom-hung rudder. 2 full suits of sails, GPS chartplotter, autopilot and wind speed/direction/depth. Trailer w/stainless disc brakes. Many more upgrades. See more at www.corsairf31forsale.com. Email bangorang16@aol.com.

35-FT MARPLES CC. \$20,000/obo. Hulls completed; Yanmar diesel installed, 5 bags of new sails, mast, boom, winches, rigging, super prop, anchors, and most everything needed to complete the boat. Marplescc35@yahoo.com.

POWER & HOUSEBOATS

37-FT CHRIS-CRAFT CONSTELLATION. 3 cabins, 1963. Emeryville. \$13,000. Great liveaboard! Classic, spacious, large windows, lots of storage, very clean. Sleep 6. New beautiful twin engines, head, carpets, fridge. Needs some underwater hull repair, estimated at \$6,000. (510) 904-2297 or zorarise@yahoo.com.

32-FT NORDIC TUG, 1998. Benicia. \$140,000. Rugged construction, fuel efficient, reliable, solid and stable: cruise in comfort and safety. 220 Cummins diesel (312 hrs.), Northern Lights genset, bowthruster, full electronics, transom door. Recently cruised R/T to Catalina - Mexico anyone? (707) 297-6535.

54-FT SAGAR 16 METER BARGE, 2002. Central France. \$290,000. Custom built for all navigable waterways. 2 Brms, 2 bath. Complete inventory for comfortable cruising. See website for photos and complete inventory. Sagar has a two-year waiting list for new build. Owner financing. See more at <http://web.me.com/cbroussard/Acadia/Welcome.html>. Email pat1083@sbcglobal.net.



65-FT WOOD CLASSIC, 1939. Heavy built ex-trawler. GMC 12V-71, 21-kw generator. Full electronics. Lots of equipment. Ready to go. Would make great conversion. Will consider any reasonable offer. More pics/details: (707) 964-5423 or ancona@mcn.org.

32-FT GRAND BANKS, 1967. Ocean Springs, MS. \$45,000/obo. Really nice. Buy as-is or I can finish. There is not \$10,000 left. New photos coming online. Lots of work done here by me. Bought larger boat. <http://webworldusa.com/gbforsale.html>. (805) 637-9748 or sundaymorning2@hotmail.com.



JORDAN SERIES DROGUE

Revolutionary Storm Survival Device
"As if by magic, stability appears out of wild movement"
Ace Sailmakers <http://JordanSeriesDrogue.com>
860 739-5999 AceSailmakers@yahoo.com

Latitude 38 eBooks

FREE ★ AVAILABLE WORLDWIDE ★
www.latitude38.com/ebooks.html

MULTIHULL YACHT DESIGNER • MARINE SURVEYOR

John R. Marples, CMS • Certified, National Association of Marine Surveyors
Multihull Design Specialist • Pleasure and Commercial
Design office for Jim Brown Searunner, Seaclipper & Constant Camber Multihulls
www.searunner.com • (707) 343-1378 • marplesmarine@comcast.net

boat bottom scrubbing & more . . .

415.331.7215 william@gotzinc.com www.gotzinc.com

Simply Great Sleep

Transform your mattress with our box-spring system and enjoy many relaxing nights aboard.

frolli

phone 888.463.7654
Nickle Atlantic, LLC
www.FrolliSleepSystems.com

See us at the Annapolis Boat Show

BLUE PELICAN MARINE
Nautical Consignments

A Sailor's Consignment Chandlery

Official Sponsor
2010
BAJA
HA-HA

510-769-4858
Located at Grand Marina
www.bluepelicanmarine.com

Mobile Marine Navigation
Installations and Marine
Electrical Work

Vessel Electric

Serving all corners of the Bay:
North, South, East -
and San Francisco!

Raymarine
certified installer

Milltech Marine AIS **NAVPOD**

Brian Theobald • (415) 424-2204 • vesselelectric@yahoo.com

ATLANTIC 57 CATAMARAN™

THE ORIGINAL PILOTHOUSE CATAMARAN

- o Designed for easy shorthanded cruising
- o Spectacular windward performance
- o Cored epoxy/glass/carbon construction

CHRIS WHITE DESIGNS
TEL: 508-636-6111
www.chriswhitedesigns.com

PARTNERSHIPS

1/4 NON-EQUITY PARTNERS IN Coronado 27. Nice interior, two jibs, solid outboard, kayak. Great berth at Sausalito Yacht Harbor. First right to boat, 1 week out of four, when available other weeks. \$150/month. For info or photos: flyboar@aol.com.

CATALINA 34 50% EQUITY partnership, Santa Cruz Harbor. \$24,000. 1989 Catalina 34 in excellent condition. Lower harbor. Full access. Great partners. (559) 312-5550, (559) 855-8277 or ark4021@gmail.com.

J/120 PARTNERSHIP. South Beach Marina, San Francisco. 50% equity ownership. Excellent condition 1998. Great sailboat for Bay racing and/or family cruising. Fully equipped with racing and cruising inventory. Great location next to AT&T Park. Serious buyers only. (650) 477-7905 or mcbowman@pacbell.net.

SAIL THE BAY BARGAIN. 1/3 deeded partnership in Catalina 27, berthed at Treasure Island, 200 hr. on new Yanmar diesel, new bottom paint, 3 jibs, reefable main, whisker pole, well equipped. 1/3 use, will train, \$4,000, share monthly expenses. (415) 282-0875.

BENETEAU 393 PARTNERSHIP. Sausalito. \$500. Clean, well maintained fast cruiser. Upgraded interior, winches, prop, diesel, full electronics, classic main, fully equipped. Qtr usage non-equity; may consider 1/8 or equity arrangement or sale. <http://marigotgroup.com/strider>. (415) 332-4401, (415) 331-4900 or 393@marigotgroup.com.



42-FT SAILBOAT in Bahamas/Caribbean. I'm offering partial ownership shares in my very well-equipped Hunter Passage 42 CC, currently located in the Bahamas. Co-owners may sail it there or may take it down into the Caribbean. \$40K for 1/4 ownership (3 consecutive months' usage each year) or \$70K for 1/2 ownership (6 consecutive months' usage each year). See the following website for more info. <http://sites.google.com/site/hendrickssailing>. (801) 792-1421 or DougHndrx@gmail.com.

PARTNER/S FOR SOUTH OF BORDER. San Rafael. Brewer ketch 45'- project for (time-share Mexico Cent/Am). Need partner/s in LLC. Solid boat, needs TLC. (512) 358-0031 or telebob@gmail.com.

SAGA 409 SAILBOAT PARTNERSHIP. Belvedere, CA. Equity ownership interest in new Saga 409 cruising sloop berthed at San Francisco Yacht Club. Semi-custom Tony Castro design built by Westerly Marine. Dual staterooms, separate stall shower, Vacuflush, Garmin chartplotter, flat screen TV, stereo, microwave, wine cellar. Spectra full-batten main with Doyle Stack Pack and lazy jacks, roller furling jib, electric halyard/mainsheet winch, Yanmar diesel, 3-blade folding prop, much more. Fast, easy to sail, great for entertaining. \$150K plus \$200/mo. (415) 298-2080 or george@kiwi-properties.com.



SOUTH OF THE BORDER



PLAN YOUR MEXICAN GETAWAY NOW. at the brand-new, gorgeous Cielo Y Mar condos. Located in Punta Mita, 35 minutes from Puerto Vallarta, available to rent from private owner. On the beach, 10 feet from the water, they offer spectacular views of ocean and mountains, the biggest infinity pool in the area, an endless beach, great surf breaks, great fishing, tremendous views of whales, bird life and the islands. While uncrowded and tranquil, just a five-minute walk to several waterfront restaurants. Choose from a spacious, beautifully furnished one or three-bedroom unit, or an amazing two-story penthouse with lovely shade trellis on the top floor. To reserve, call: Dona de Mallorca at (415) 599-5012. See details: www.puntamitabeachfrontcondos.com.



CHARTER DIRECT & SAVE \$\$\$\$. Owner's time available for discount charter. Beautiful Robertson & Caine 4600 cat, *Hope*, featured in *Latitude 38*. Based in beautiful Belize. Book direct and save big bucks. pettyd@comcast.net.

SailTime: The Hassle Free Alternative to Boat Ownership

Join SailTime for a non-equity membership on our 2011 Hunter 36 – no hidden fees – just \$695 a month.

www.SailTime.com • (415) 869-2861

Offshore/Coast Passagemaking Mexico 2010-11 • Leg 1-Baja Ha-Ha

Learn passagemaking and cruising skills from sailing veteran: daily hands on participation in instruction material, sailing drills and safety checks. Captain references w/combined 85 years experience. 805-481-4567

Instruction / Itinerary / Package Details • www.cruisingexpeditions.com



VALLARTA CATAMARAN CHARTER. Puerto Vallarta. Low season rates! Come sail with us on famous *HumuHumu* in perfect Banderas Bay conditions. Full day, Long Weekend or Costa Alegre Discovery Cruise. Vallarta has it all! www.catpv.com. (760) 681-7825 or (760) 975-5850 or info@catpv.com.



OFFSHORE/COASTAL Passagemaking Instruction. Build passagemaking and cruising skills. Captain ref. w/combined 85 years experience. Limited sailing experience OK, eagerness to get involved, understanding you're on an adventure, safety of the boat and your fellow crew members comes first. See more at www.cruisingexpeditions.com. (805) 481-4567.

TRADE

MOVING TO CARIBBEAN! Arizona. \$400,000. Looking to trade/sell 3+ year-old successful cigar lounge/business worth \$400K in Arizona for a 38-ft or larger sailboat. Ready to start new chapter in our lives. Serious inquiries only. www.BigSticksFineCigars.com. (602) 810-1665 or trade@bigsticksfinecigars.com.

TRADE FOR BOAT WORK. and/or slip fees. Sailing Monterey. \$Negotiable. Trade sailing with or w/o lessons. Crealock 37 in Monterey for boat work and/or slip fees. ddatpbio@gmail.com.

TRADE PROPERTY for cruising sailboat 32ft-larger. Two lots in Clearlake: 1) view lot in Kono Tayee, utilities paved road, etc. Appraised 1990 @ \$19,900. 2) lot on the shoreline, suitable for dock. Appraised 1994 @ \$8,800. Copy of appraisals on request. carlo@surewest.net.



GEAR

PRO FURL MODEL B35M \$1,000/OBO. Pro Furl Model B35M with seven lengths of foil. Excellent condition. (209) 223-2183 or oannio@comcast.net.

AUTOPROP FEATHERING PROP. Chamanche. \$2,000/obo. Model H5-470, in mint condition, suitable for Beneteau, Catalina, Jeanneau, Hunter, Caliber, or other sail boats of about 40-ft. Check www.ab-marine.com for suitability for your boat. www.ab-marine.com. (209) 223-2183 or oannio@comcast.net.

NEW: PARATECH15, FIORENTINO12.9. Paranchors-Drogues. Windvane wheeladapter, storm jibs, folding mast steps, Mastmate, MOM8, Blipper. Lift-crane: Forespar Motormate/ Cargomate-Garhauer. Walker tafflog, Drivesaver, rigid boomvang, windlasses, Force10 keroheater, Avon motor bracket, solar, inverters, Dometic 3way, anchors, headsails, Davis sextant, winches: Arco40s, Southcoast. (415) 497-3731 or brad-low@sbcglobal.net.

YANMAR 50 HP DIESEL ENGINE 4JH2E. Santa Cruz. \$2,000. 1997 engine in Catalina 42. In running condition for testing and inspection. Strong four-cylinder engine that starts easily, no smoking or overheating. Gear box (KM4A) not working. (831) 685-8823 or danasc40@sbcglobal.net.

BIG RIG MAST AND BOOM. Costa Mesa. \$10,000. Mast 79' 2" length, heavy wall. Oval section 14"x10.5" tapers to 9.5". Includes 4 sails and 30-ft boom. Includes shrouds, stays and Hood furling. Excellent condition. (949) 548-4192 or minneys@aol.com.

74-FT MAST. designed for catamaran. Best offer. (415) 269-5165.

UNIVERSAL M25XPB 26HP. diesel in-board. Seattle area. \$5,000. Like new-149 hours. Currently installed in my sailboat in Winslow Wharf Marina (Bainbridge Island). Come see it run. Includes prop, shaft, panel, fuel filter, cooling system, throttle/shift control. \$5,000 FIRM or trade toward 30'+ 5th wheel/travel trailer. (360) 643-9113 or jn5289@yahoo.com.

52' PEARSON 37 MAST., rigging and sails. Monterey/Pacific Grove. \$Best offer. The sails and rigging are unused, and the mast is in fine condition. Mast size is 8" x5 1/2". (831) 649-1249 or (831) 419-1051 or loomis15885@att.net.

SAIL COVERS. Loch Lomond Marina, San Rafael. \$800/obo. Sail covers - Pacific/aqua blue - brand new for 14' 4" main boom and 10' mizzen boom. Never been on boat. (415) 302-9841 or (415) 342-2508, 110 Loch Lomond Drive or email chriscoykendall@att.net.

MISCELLANEOUS

TEAK WOOD DECKING FROM BURMA. Magalia, CA. Best offer. Teak decking Burmese old growth, not plantation. Bought Oct. 1981 from American Marine Singapore. Builders of Grand Banks Yachts. Invoice shows 629 bd' 134 at 12', approx 2081' 11/2"x9/16" finished 4 sides, with 1/4x1/4 notch cut in. Kept inside and dry, like new. Have original paperwork. Selling as one unit \$9,000/obo. 44 books, authors: Hayden, Hal Roth, Donald Street, Williams, Hiscok. (530) 873-1179, (530) 873-7086 or hudolo@yahoo.com.

CLUBS & MEMBERSHIPS

SINGLE SKIPPERS AND CREW of all abilities are invited to join the Single Sailors Association. Membership includes daysailing, raft-ups, invaluable onboard training, social events. Meetings held 2nd Thursday, Ballena Bay Yacht Club, www.bbvc.org. Social; 6:30 pm. Meeting; 7:30 pm. Guests welcome. More info at www.singlesailors.org. (510) 233-1064.

PROPERTY SALE/RENT



HOME FOR RENT with deep water berth, Alameda. \$3,150. 3 bedroom 2 1/2 bath home on the water with private 36-ft boat dock plus dinghy dock. Views of the San Francisco Bay from every room. Spacious and open, approx 2300 sq feet of living space with cathedral ceilings and filled with bright natural light. Huge master bedroom suite with private upper deck overlooking the Bay. Private gate entry with direct access to your boat. Quick access to San Francisco. Attached two-car garage plus plenty of off-street parking, laundry room, large kitchen with breakfast area. This home also may be made available furnished. Must see! More at <http://picasaweb.google.com/SumaLandscape/BallenaBest?authkey=Gv1sRgCIH42v2yutqW8wE&feat=directlin>. (510) 421-8000 or susanfrank@comcast.net.



WORKING WATERFRONT OFFICE(S). Pt. Richmond. \$1,000/month. Timberwharf Office(s): Overlooking Santa Fe Canal and the KKMI Marina. 1,000 square feet, easily divided. Includes two private restrooms. \$1,000 per month plus utilities. Contact Paul Kaplan: www.kkmi.com. (510) 235-5564 or paul@kkmi.com.

AMERICAN SAILOR SELLING. harbour-side home. Whangarei, New Zealand. \$US 400,000 FIRM. Fully-furnished home, pool, gardens overlooking harbour in the Onerahi suburb of Whangarei - a major re-outfitting port in Northland New Zealand. Extensive SW Pacific and Kiwi cruising community with spectacular local sailing. Intermittently lived NZ 40 years - ten in house - now at age 72 simplifying life and moving back aboard our one-off 40' Kauri cutter on marina. Website for details and 130 Flickr photos: www.americankiwihome.com. (303) 494-3154 or neptune@ecentral.com.



BOATERS PARADISE. St. Petersburg, FL. Extraordinary views, 237' on deep water. 3BR, 3.5BA, huge garage and workshop, big lot, dock 100', boat lift, cul-de-sac. Minutes to Gulf of Mexico, 45 minutes to Tampa airport. For full details, Google MLS 7472362. (727) 698-3000 or hercomesthesun8888@yahoo.com.

BERTHS & SLIPS

EMERY COVE MARINA. 45-FT slip for sale. Emeryville. \$39,900. 45-ft downwind slip at the end of B dock for sale. Easy access to the Bay in the best marina in the area. Priced to sell. rojbrown@me.com.

50-FT PRIME SLIP PIER 39, SF \$46,000. F-Dock, Slip 11, east side. Protected from wind. Close to gangway, showers and marina office. Covered parking across street with special rates for owners. (559) 355-6572 or scorch@tempest-edge.com.

36' SLIP, SF PIER 39 \$8,750. "C" Dock, Slip 26. Marina offers special parking privileges at Pier 39 garage. (831) 624-4910 or ted@twjohnston.com.

MARINE ENGINE CO.

Complete Engine Services • Gas & Diesel
30 Years Experience • Reasonable Rates
Tune-Ups • Oil Changes • Engine Rebuilding, etc.
(415) 332-0455

For the best - and most exposure - of your classified ad...
submit your ad safely online at: www.latitude38.com.

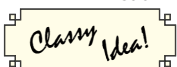

Your ad will be posted online within two business days, appear in the next issue of the magazine, and remain online until the following issue is released.



Get the Reliable, Powerful Wheel Pilot

Quiet & Dependable • Affordable • Built for Immersion
Easy Owner Installation • Low Power Consumption
831-687-0541 www.cptautopilot.com

YOGA FOR SAILORS ON THE WATERFRONT

Gentle yoga class at Oakland YC Saturdays 8-9 am starting Sept. 4. Beginners welcome! Donation-based; all proceeds benefit Alameda Food Bank. See www.bowoyoga.com. yogaforu2009@gmail.com, (415) 785-4530, (510) 333-8846



GOLDEN STATE DIESEL MARINE

PARTS
YANMAR • UNIVERSAL • WESTERBEKE
PERKINS • ISUZU • PATHFINDER • ATOMIC 4

SERVICE
DIESEL ENGINES

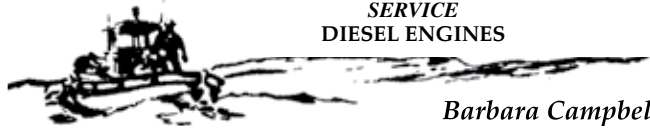

Barbara Campbell

351 EMBARCADERO
OAKLAND, CA 94606

(510) 465-1093

Oil Paintings
by
Ian Wilson-Dick

Open Studio
October 9-10 & 16-17
or by appointment
Visit our new studio in
Petaluma, California
(707) 769-9588



www.ianwilson-dick.com



**1,000 Used Sails
Listed at
minneysyachtsurplus.com**

**We Buy Good Used Sails
and Marine Equipment**

MINNEY'S YACHT SURPLUS

1500 Newport Bl., Costa Mesa, CA

949-548-4192 • minneys@aol.com

"We keep boating affordable!"

KATADYN SURVIVOR 35 WATERMAKER

The Survivor is a must for all sea-going vessels and is the most widely used emergency desalinator. It is used by the U.S. and international forces. It is able to produce 4.5 liters of drinkable water per hour. These are unused U.S. government surplus.

Reconditioned by Katadyn **\$950.**
Compare to factory new price: \$1,995.

For more information or
to place an order, please
call one of our sales reps.

Equipment Parts Sales
In the U.S.: (800) 417-2279
Outside the U.S.: (717) 896-9110



CREW

80-FT SCHOONER. Leaving For Mexico Mid-November. Destination Puerto Vallarta. Captain seeking several passengers/crew. Experience the adventure of a lifetime. For details contact: phschrtiama@hotmail.com.

PERSONALS

SEEKING SAILMATE. Very attractive lady, slender, great figure, smart, 60, Sonoma County, loves sailing. Former boat owner desires fun, interesting, sexy man for possible LTR. Love nature, cooking, reading, music, dancing, very liberal worldview. Have sight deficit but not to worry. gardenia@sonic.net.

JOBS WANTED

CARETAKER. Pets, garden, family, and project manager while you're cruising or racing. Bilingual educator, arborist, native of Marin, non-smoker. References. Call Marlaina. (707) 951-3254 or email aspenseer@yahoo.com.

JOB OPPORTUNITIES

GOOD BOAT WORKER WANTED. Trade for 50% ownership Cal 25. On trailer, we can locate conveniently. Finish boat for 1/2 title ownership. Hull, deck and rigging are restored. Have all deck hardware and equipment to finish. Need labor and completion effort to finish this boat. Have 3DL sail set and extra gear to make this a great boat. I need to work with a partner to finish it because I've taken work out of state and can't be present. Will work out a good partnership deal to go forward fairly. Just want to finish this project. I have the fabrication and support capability, I am looking for a facilitator partner. (408) 500-2038 or hurricaneagain@yahoo.com.

BOAT SALES PERSON. Work in a beautiful tropical environment - knowledge of power and sail is a necessity, good with people, friendly, comfortable office. Spanish and English is a big plus. Email tropicaljob@gmail.com.

DOCK MAINTENANCE WORKER. East Bay. Large East Bay marina is seeking a self-motivated dock maintenance worker. Ideal candidate will possess plumbing, electrical and carpentry skills. Boating experience a plus. Must be willing to work Sundays. Full time w/ benefits, salary DOQ. Fax resume to (415) 421-3167 or email MarinaEstuary@yahoo.com.

BUSINESS OPPORTUNITIES

SAILS! SAILS! SAILS! SAILS! Major sailmakers' California sales office/territory. Well established, low overhead, Grand Marina location. Owner retiring. Will train. Sailing experience, people skills a must. \$10K. Terms available. Fun part-time job for semi-retired sailor/sailorette. leesailsnc@yahoo.com.

EARN YOUR LIVING ON THE WATER! Currently Servicing SF East Bay Area. Well-established and respected boat-based holding tank pumpout service with great clientele for sale. Excellent part-time income with real potential for growth. Turnkey operation includes 21' Boston Whaler Outrage, professionally-maintained 2005 Mercury 90hp four-stroke outboard and complete, top-of-the line onboard pumpout equipment, galvanized Pacific dual axle trailer and a very low-mileage 1996 Ford E-250 tow vehicle. Will sell all or part and will train. (925) 429-4490 or matt@head-honcho.net.



STEARNS WHARF. Charter Business. Santa Barbara Harbor. \$Best Offer. Seeking parties interested in operating a coastal cruising business from Stearns Wharf which may include gray whale watching, sunset cruises, dinner cruises, etc. Contact (805) 897-1969 or Sriedman@SantaBarbaraCA.gov.



**NEED
CASH
FAST?**

Advertise your **USED MARINE GEAR**
in our *Classy Classifieds*

THIS STUFF SELLS FAST!

Deadline is the 18th at 5pm. See page 168 for details.

Bay Racing...
Where the action is!

2011 RACING IS COMING *FAST!*



Plan to promote in *Latitude 38's*
**2011 Northern California
SAILING CALENDAR**

For more information contact: john@latitude38.com or shawn@latitude38.com

JUST YOU AND THE SEA...

...and the jacuzzi,
the 80-ft long pool, the surf,
the Punta Mita anchorage, and the 4-mile distant
Tres Marietas Islands

Punta Mita Beachfront Condos

Call Doña de Mallorca for reservations!

1.415.599.5012

www.puntamitabeachfrontcondos.com

ADVERTISERS' INDEX

AB Marine.....	60	Blue Pelican	176	Davis Instruments.....	148	Golden State Diesel Marine	178	KKMI - Full Service Boatyard	188
Adventure Cat Charters	26	Blue Sky Energy	122	DeWitt Studio	181	Grand Marina	2	KKMI - Rigging	36
Islander 36 Fleet	138	Blue Water Yacht Insurance..	56	Diesel Fuel Filtering	149	Hansen Rigging	63	KKMI - Systems/Electronics ..	48
Almar Marinas	51	Bluerush Boardsports	141	Downwind Marine.....	24	Harbor Island West Marina.....	163	Landing School, The	147
Alpenglow Marine Lights ...	170	Bluewater Network.....	174	Doyle Sails	25	Harken	14	Larry R. Mayne Yacht & Ship Broker	10
American Battery	149	Boat Yard at Grand Marina, The	21	Easom Rigging.....	103	Helms Yacht & Ship Brokers/ West Coast Multihulls	182	Lee Sails	149
Bacon Sails & Marine Supplies	63	Boatswain's Locker	31	El Salvador Rally/ Bahia del Sol.....	35	Helmut's Marine Service.....	73	List Marine Enterprises	20
Baja Ha-Ha Beach Party	121	Bottom Siders.....	170	Emery Cove Yacht Harbor....	67	Heritage Marine Insurance... 70		Loch Lomond Marina	149
Baja Ha-Ha Sponsors	123, 124, 125	Brisbane Marina	65	Emeryville Marina	165	Heritage Yacht Sales.....	185	Lunasea Lighting	148
Ballenger Spars.....	67	BVI Yacht Charters.....	144	Equipment Parts Sales.....	178	Hidden Harbor Marina.....	77	Mack Sails.....	8
Bay Area Boat Works	62	Cal Maritime Academy.....	139	Essex Credit Corp.....	46	Hogin Sails.....	50	Makela Boatworks.....	172
Bay Island Yachts	8	Call Of The Sea	144	Euro Marine Trading	75	Hood Sails.....	43	Marina Bay Yacht Harbor	37
Bay Marine Boatworks.....	53	CDI/Cruising Design	75	Fago, Margaret Artist.....	72	Hotel Coral & Marina	164	Marina de la Paz	120
Bay Marine Diesel.....	172	City Yachts.....	11	Farallone Yacht Sales.....	6, 7	Hotwire Enterprises.....	172	Marina El Cid	118
Bayside Canvas	69	Coast Marine.....	78	Ferreteria Zaragoza	167	Hydrovane.....	118	Marina Mazatlan	49
Bellhaven Yacht Sales & Charters.....	146	Costa Baja Resort & Marina.....	45	Flying Cloud Yachts	184	Ian Wilson-Dick, Artist.....	178	Marina Nuevo Vallarta	42
Berkeley Marina.....	29	Cover Craft.....	70	Forespar.....	69	John Beery Yachts	183	Marina Puesta Del Sol	166
Berkeley Marine Center	129	Coyote Point Marina.....	47	Fortman Marina.....	71	Katadyn	108	Marina Riviera Nayarit.....	34
Beta Marine Engines.....	71	Cruising Yachts	9	Garhauer Marine.....	39	Kissinger Canvas.....	129	Marina Village.....	33
		CYOA Yacht Charters.....	145	Gentry's Kona Marina	167	KKMI - Brokerage.....	184	Marine Lube	149
				Gianola Canvas Products... 147					



Jim DeWitt is 80! He's looking great!

deWitt

**Join us in celebrating
Jim DeWitt's 80th year!**

The entire month of November,
we will be having a retrospective show
of Jim's work through the years.

A reception to visit with Jim
and view the art collection will be held
Thursday, November 18 • 5:30-8 p.m.

DeWitt Art Gallery & Framing

121 Park Place, Point Richmond, CA 94801

(510) 236-1401 • (800) 758-4291

www.jimdewitt.com

www.dewittgalleryandframing.com

Wednesday-Saturday 11:00-7:00

Sunday 9:30-5:30

ADVERTISERS' INDEX *cont'd*

Marine Outboard Co..... 52	North Direct Sails..... 73	Quantum Pacific..... 19	South Beach Harbor 54	Vessel Electric..... 176
Mariner's General Insurance 160	North Sails - San Francisco .. 79	Quickline..... 68	South Beach Riggers..... 55	Voyager Marine..... 77
Maritime Institute..... 74	Opequimar Marine Center..... 166	Raiatea Carenage Services 161	Spud Point Marina 114	W.D. Schock Corp. 65
Marotta Yachts 186	Orange Coast College..... 57	Remote Satellite Systems 119	Sta-Lok Terminals 20	weatherguy.com..... 167
Mathiesen Marine 174	Outboard Motor Shop..... 79	Richardson Bay Marina 75	Starbuck Canvas 8	Wedlock, Ramsay & Whiting Marine Surveyors 174
Mazatlan Marine Center / La Paz Yachts..... 13	Owl Harbor Marina 128	Rooster Sails 77	Surveyor - Jesse Brody..... 170	West Marine..... 28, 30, 59
McDermot Costa Insurance .. 72	Oyster Cove Marina 167	Sail California..... 16, 17	Svendsen's Boat Works 23	West Marine - Rigging..... 64
McGinnis Insurance..... 68	Oyster Point Marina 79	Sail Warehouse, The 172	Svendsen's Marine 40	Westpoint Harbor..... 58
McGrath Yachts..... 15	Pacific Crest Canvas 63	Sailrite Kits 18	The Dinghy Doctor 78	Westwind Precision Details... 55
Mettec, Inc..... 67	Pacific Rigging 74	Sal's Inflatable Services..... 76	TMM Yacht Charters..... 145	Whale Point Marine Supply 38
Michael Wiest Yacht Sales . 183	Pacific Yacht Imports..... 12	Salt Harbor Studio..... 76	Trident Funding 4	White, Chris Designs 176
Milltech Marine Inc..... 44	Pantaenius America, Inc. ... 174	San Francisco Boat Works . 140	Ullman Sails..... 120	WinchRite / Sailology 66
Minney's Yacht Surplus 178	Paradise Village..... 61	Sausalito Marine Electrical Shop..... 73	Vallejo Marina 146	Yachtfinders/Windseakers ... 10
Modern Sailing School & Club 27	Passage Yachts..... 5	Scanmar International 32	Variprop USA 69	
Napa Valley Marina Yachts 182	Pettit Paint..... 41	Schoonmaker Point Marina .. 22	Ventura Harbor Boatyard... 164	
Nickle Atlantic/ Froli Sleep Systems..... 176	Pier 39 Marina 109	Schaefer Marine 115		
Norpac Yachts 187	Pineapple Sails 3	Schoonmaker Point Marina .. 22		
North Beach Marine Canvas 55	Pirate's Lair 102	Sea Frost 66		
	Pittsburg Marina 162	Seashine..... 129		
	Punta Mita Beachfront Condos 180	Seatech 170		
		Shadetree Fabric Shelter 71		



M U L T I H U L L S



SEAWIND 1160 Call us about charter test sail.



CHRIS WHITE HAMMERHEAD 54



PDQ 32 ALTAIR
Two boats from \$139,000.



CORSAIR 24 MKII
\$34,000.



GEMINI 105M
\$124,000.



36' SEAWIND 1000XL, 2001
Two boats from \$169,000.



CORSAIR SPRINT 750
2 starting at \$49,500.



31' CORSAIR, 1998
\$105,000.



Dealer for Seawind Catamarans
and Corsair Trimarans

www.helmsyacht.com
(510) 865-2511



CORSAIR 28CC, 2005
\$89,900.
Corsair 28AC, 1998
\$59,000.

SERVING THE BOATING COMMUNITY SINCE 1957



37' ISLANDER SLOOP
1968 • \$21,900



32' CORONADO AFT CABIN
1973 • \$19,950



35' AMUTHON STEEL SLOOP
1966 • \$18,500



56' FOUNTAINE PAJOT MARQUISES
2001 • \$595,000



44' SIRENA
1988 • \$109,000



36' BENETEAU 361
1999 • \$89,500



45' C&L EXPLORER CUTTER
1979 • \$59,500



47' COLIN ARCHER STEEL PH KETCH • 1972 • \$69,500



39' PEARSON 390 CENTER COCKPIT • 1972 • \$32,500



40' NEWPORTER STAYSAIL SCHOONER • 1957 • \$29,500



48' C&C PH CUTTER
1982 • \$95,000

49' American Marine Alaska, '74.....	\$ 66,250
48' Rampart Motor Yacht, '69.....	\$ 98,500
47' Bluewater Islander, '74.....	\$ 39,500
46' American Marine Alaska, '70.....	\$ 38,500
46' Chris-Craft Constellation, '63.....	\$ 59,900
42' Uniflite Sportfisher, '80.....	\$ 29,500
40' Dyer Fly Bridge Trawler' 82.....	\$ 98,500
40' Matthews Custom Classic, '49.....	\$ 55,000
39' Sea Ray 390 Express' 89.....	\$ 59,500
39' Sea Ray 390 Express, '89.....	\$ 49,500
38' Chris-Craft 382 Commander '85...	\$ 89,500
30' Chris-Craft, '68.....	\$ 6,200



NAPA VALLEY MARINA YACHTS

(866) 363-8882 • (707) 252-8011

1200 Milton Road • Napa, CA 94559

www.napavalleymarina.com

Marina • Boatyard • Chandlery • Brokerage

Dealers for
YANMAR

Interlux
yachtpaint.com

Distributors for *Brownell*
Boat Stands

Michael Wiest Yacht Sales

QUALITY PRE-OWNED SAILBOATS



51' BENETEAU 510, '92..... \$189,000



49' BENETEAU SLOOP, '07..... \$445,000



47' SORENSEN CELERE, '88... \$359,000



45' MORGAN STARRATT, '79 \$49,000



44' SWAN, '74..... \$125,000



44' HUNTER CALL



44' TARTAN 4475, '75..... \$79,000



43' IRWIN MkII, '88 \$119,900



42' HUNTER PASSAGE, '95..... \$99,000



40' BAVARIA SLOOP, '01 \$179,000



36' BENETEAU 361, '00..... \$99,500



36' HUNTER 356, '03..... \$99,500



33' HUNTER SLOOP, '91 \$39,500



32' CATALINA 320, '98 \$65,000

CHECK THEM OUT AT

www.michaelwiestyachtsales.com

then call

(510) 601-5010

Emeryville, CA

JOHN BEERY YACHTS

Welcomes

DICK MAY

Dick has returned to the Bay Area to offer his 40 years of experience selling new and used sailboats to Northern California



Dick May and John Beery

sailors. He has unmatched experience and product knowledge, giving the buyer or seller a distinct advantage when trading up or finding that perfect boat.

John Beery Yachts

Originally established in 1958

John Beery Yachts has helped thousands of sailors buy, sell and learn to sail on San Francisco Bay. Founder John Beery is recognized for both his sailing and business success.

*For first class service,
list your boat with John Beery Yachts*

Featured Brokerage



42' Valiant, 2003

The ultimate blue-water cruiser in immaculate condition.

Cal 31, 1979...\$17,500

Mariner Square, Alameda

(510) 521-2727

*For more information and listings,
please visit:*

www.johnbeeryyachts.com

Dick May • Kenn Wright
Rosivaldo Rocha



Flying Cloud Yachts



Hans Christian

GEMINI

Sail • BROKERS • Power

www.yachtworld.com/fcyachts
flyingcloud@verizon.net

MEMBER
Boat Wizard
M.L.S.
PETERBOROUGH

6400 Marina Drive
Long Beach, CA 90803

Phone (562) 594-9716
Fax (562) 594-0710



BENETEAU 473, '05 \$265,000



46' HYLAS, '06 \$595,000

TWO CATALINA 380s



2001 Hard Dodger,
LOADED! \$140,000
1998 Real nice! \$115,000



43' TASWELL, '89 \$259,000



36' HUNTER, '05 ~~\$124,900~~ \$109,500



37' CF SLOOP, '78 \$24,900



38' HANS CHRISTIAN, '86 \$149,500



IRWIN 42, '77 \$59,500



47' GILS CATAMARAN, '02 Make Offer



GEMINI CATAMARANS, 4 from \$49,900



42' CATALINA, '93 ~~\$118,000~~ \$109,000

APPROX. 100 LISTINGS ON OUR WEB SITE: www.flyingcloudyachts.com



Maritime Yacht Brokerage

(510) 236-6633 • fax: (510) 231-2355
yachtsales@kkmi.com • www.kkmi.com
530 W. Cutting Blvd., Pt. Richmond, CA 94804

LIST WITH US! Ask us
about our Maritime
Protection Program



SWAN 40 (1996) Frers design, exceptionally well maintained, 2-cabin performance cruiser. Awl-grip Flag Blue hull, comprehensive sail inventory, and full in-slip cover. Asking \$299,000



HINCKLEY BERMUDA 40 MkII Yawl CB (1968) Bill Tripp design is highly regarded for classic beauty, superb workmanship and quality details. New sails, dodger, intelligently updated. Excellent condition. Asking \$147,000



LITTLE HARBOR 51 (1996) Very comfortable Ted Hood designed pilothouse with full stand-up headroom and 360° visibility. Set up for shorthanded sailing and superbly maintained by an experienced owner. Asking \$619,000



JARVIS NEWMAN 36 (1978) Classic flybridge 'lobster boat' of Maine build quality. Single engine (160 hours), queen V-berth with enclosed head. Excellent condition, well maintained and lightly used. Asking \$129,000



SWAN 45 (2003) Race or cruise. *Rancho Deluxe* won her class in the TransPac and was second twice in the Big Boat Series. This boat has all the gear to go cruising and is in perfect condition. \$525,000



BALTIC 42 DP (1984) Since 1973, Baltic Yachts of Finland have been building comfortable, safe, long distance cruisers with very good sailing and performance characteristics. Doug Peterson design, superbly maintained, hull #29. Asking \$165,000



NELSON MAREK CUSTOM A 92-ft aluminum world cruiser. Recently repowered. Immaculate through-out and in perfect condition. \$1,500,000

HERITAGE

Yacht Sales

Live your Dreams



Long Beach-Naples
Newport Beach
Wilmington

231 North Marina Dr. 866-569-2248
829 Harbor Island Dr. 877-389-2248
Berth 202 Peninsula Rd. 877-599-2248
Cell. 310-995-9989

www.heritageyachts.com

FEATURED LISTING

46' HYLAS
2006
LA HARBOR
\$599,500



SISTERSHIP

65' MacGregor
PH 1994
\$220,000



50' Garden Steel
Ketch 1969
\$149,000



49' Transpac
1984
\$189,900



45' Hunter Legend
1986
\$79,000



40' Catalina
1998
\$129,000



38' Downeast
1979
\$49,000



YOUR SOUTHERN CALIFORNIA ALERION EXPRESS DEALER

33' Alerion Express
2011



28' Alerion Express
2011





Marotta Yachts of Sausalito

Brokers of Fine Sail and Motor Yachts

415-331-6200 • info@marottayachts.com • www.marottayachts.com

See at: www.marottayachts.com



50' STEPHENS, 1966 Stephens were all expensive custom builds and this is a prime example. Over \$500k spent on her since '04; updated inside/out but retains her original stately lines and elegant ambiance. Possible Sausalito transferable slip. **\$227,000**

See at: www.marottayachts.com



41' SCEPTRE RAISED CABINTOP CUTTER, 1985 Professionally maintained local boat shows VERY nicely inside and out. Leisure Furl in-boom system w/Hood main, Harken roller furler and 105% Hood jib, updated electronics, more. **\$195,000**

See at: www.marottayachts.com



40' BENEteau FIRST 40.7, 2003 The First 40.7 combines the excitement of a sleek racer with all the comforts of a luxurious cruiser. This one is a well-equipped beauty that shows new inside and out. She's the deep version (preferable for the Bay). **\$169,000**

See at: www.marottayachts.com



43' HANS CHRISTIAN, 1978 Classic offered for sale by original owner. New teak decks (this was a \$40,000 job alone!), Awlgrippd hull, updated interior, optional larger diesel and Telstar performance keel. **\$159,000**

See at: www.marottayachts.com



37' HUNTER 376, 1999 Very spacious, light and airy, this vessel shows as new; must see to appreciate. Out-of-country owners motivated; offers encouraged. Sausalito Yacht Harbor slip can be arranged. **\$97,000**

See at: www.marottayachts.com



48' C&C LANDFALL CUTTER, 1980 Landfall is C&C's first large boat w/emphasis on cruising. This one is a spacious 3-cabin, 2-head cutter that's VERY competitively priced and lying in a transferable Sausalito slip. Motivated owner is encouraging offers. **\$89,000**

See at: www.marottayachts.com



32' CATALINA 320, 1998 Very clean (down below shows as new) and well fit out (chartplotter, AP, heat/AC, dodger, bimini, etc.) deep draft model that's competitively priced and lying in a transferable Sausalito slip – a nice turn key package! **\$74,950**

See at: www.marottayachts.com



41' MORGAN OUT ISLAND, 1979 Center cockpit ketch. Never cruised and fresh water kept, she shows much newer than actual age. Note all new stainless steel ports. **\$64,000**, offers encouraged.

See at: www.marottayachts.com



38' INGRID SLOOP, 1984 Clean, never cruised, one owner example of this classic John Atkins design. A modern adaptation of pilot boats designed by Colin Archer for North Sea conditions, the Ingrid is the gold standard for capable cruisers. **\$59,000/Offers**

See at: www.marottayachts.com



36' UNION CUTTER, 1980 Heavily built full keel canoe sterned classic, designed by Robert Perry and built by the renowned Union yard in Taiwan. Repowered, aluminum mast, riggered. Offers encouraged. Competitively priced at **\$59,000**

See at: www.marottayachts.com



38' C&C, 1980 C&C is known for producing fast, good looking and well built boats, and this is a prime example: she shows very nicely (especially her oiled Burma teak interior), is competitively priced and sails like a witch – a very nice combination. **\$49,000**

See at: www.marottayachts.com



38' MORGAN, 1981 Morgans are well known for quality construction and seaworthiness; high D/L ratio of 265 and long fin keel provide a comfortable ride in the Bay's boisterous conditions. Very clean in and out, with recent, dark blue Awlgrip. **\$45,000**

See at: www.marottayachts.com



40' CHALLENGER KETCH, 1973 Recently Awlgrippd in beautiful Flag Blue, renewed brightwork, incredibly spacious below with 6'5" headroom. **\$43,500**

See at: www.marottayachts.com



35' PEARSON SLOOP, 1981 Built in Rhode Island to typical Pearson standards, this is one of the last 35s built and has been a local boat since 1983. In very nice shape, priced right and lying in a transferable Sausalito Yacht Harbor slip. A nice package! **\$35,000**

See at: www.marottayachts.com



34' HUNTER, 1984 Very roomy 34-footer in nice shape with transferable Sausalito Yacht harbor slip. Note deep draft, Yanmar diesel, custom hard dodger, oversize winches, radar and chartplotter. Competitively priced by motivated owner. Offers encouraged. **\$24,900**

at 100 BAY STREET • SAUSALITO • CALIFORNIA 94965 since 1946

NORPAC YACHTS



1150 Brickyard Cove Rd., B9, Pt. Richmond, CA 94801
(510) 232-7200 • FAX (510) 232-7202
 email: info@norpacyachts.com

We Are SELLING Our Boats & NEED MORE LISTINGS!
THIS is the time: LIST YOUR BOAT with NORPAC!



133' CAR FERRY Conversion: Office/Studio. Ultra spacious. Fully operational. Set up for very comfortable living and working. Ice Class, built in Norway. Fine condition. Absolutely unique and VERY cool. Rare opportunity. **\$375,000**



40' X-YACHTS X-119 SLOOP. Famous Danish builder, racer-cruiser one design by Neils Jeppesen. Loaded with gear, radar, new Volvo Penta diesel in 2000 and MORE! Proven ocean winner in Melbourne-Osaka Race. Asking **\$109,000**



48' DUTCH CANAL BARGE by DeVries. STEEL. Unique cruising liveboard for Bay and Delta. Comfort and character. Diesel, tub, galley, fireplace, salon, convertible aft enclosure, beautiful decor, plus MORE! Asking **\$219,000** /Offers



39' BENETEAU 393 LIKENEW! Light use. Dsl, dodger, 2 private stms, 2 heads w/showers, furling, self-tailers, new genny, main, Pryde 95 & 150 jibs, wheel/pedestal, pulpits, inverter, full galley mid-ship, conv w/ settee/ship's table, ++ **\$149,950**



41' CT-41. Exquisite example of this revered Garden design w/many custom features. Fiberglass, big dsl, teak deck, cabin heat & fireplace, tiled shower & head, gorgeous interior, alum. spars, full galley, refrigeration & much MORE! MUST SEE... Asking **\$78,950**



MAKE MONEY AND HAVE FUN!
 Established and unique SF Bay charter business featuring exotic dancers (girls and/or guys for ladies and/or gentlemen), liquor service, comfortable and spacious charter yacht w/tasteful traditional styling/ decor. COI for 49 passengers. Turnkey operation, owner retiring. Asking **\$295,000**/pos. seller financing.



TRY AN OFFER
36' ISLANDER Slp. Well respected and outstandingly popular Alan Gurney design. Wheel steering, dsl, full dbl lineflines w/pulpits, modified fin w/skeg-hung rudder, self-tailers, rigged for short-handed sailing, furling, well laid out and comfortable down below. New trans, dodger and MORE! Asking **\$44,950**



EXQUISITE CLASSIC
38' CLASSIC ENGLISH KETCH. Award winning beauty, fine condition. Pitch pine over oak, copper riveted. Dsl, dodger, new teak decks, radar, gorgeous interior & MORE! **\$99,950**



MAKE AN OFFER
36' STEEL HARTOG KETCH. Robust bluewater cruising doubled-ender, 1985. Low hours diesel, radar genset, air conditioning, watermaker, RIB and outboard, O/S liferaft, vane, wheel, pulpits, 2x course lifelines and MORE! GREAT BARGAIN on a go anywhere cruiser! Asking **\$49,950**



BERTHED IN SAUSALITO
101' STEEL TUG in downtown Sausalito. This great YTB is operational, a fantastic opportunity with loads of potential! Bring your imagination, she's awesome, highly desirable & a fabulous value. Asking **\$44,950**

Visit us at BEAUTIFUL & FRIENDLY Brickyard Cove Marina

SAIL
 100' MEGA SLOOP Custom Offshore Performance Cruiser. Comfort & luxury, spacious, sleeps 17, loaded and near new. GREAT CHARTER POTENTIAL!!!! Asking 975,000
 58' ALDEN Boothbay Ketch. Center PH cockpit, aft S/R, dsl, heavy glass, world cruiser. AWESOME! Asking 268,950
 38' INGRID Ketch by Atkins. Great extra STOUT BLUE WATER CRUISER. Glass double-ender, refit & upgraded, vane, diesel, furling, RADAR & MORE! Asking 51,950
 38' CLASSIC English Ketch by Reg Freeman. Breathtaking beauty. **Reduced by 25,000!** Asking 99,950
 33+ ROYAL HUISMAN ALUMINUM Cutter by Alan Gurney; World class builder and designer. Yanmar diesel, new standing rig, nav station, liferaft & MORE! Family emergency forces 50% PRICE SLASH. Must sell NOW! This is way too cheap for this vessel! Asking 19,250
 32' GULF P/H by Wm. Garden. Diesel, F/G and MORE Asking 13,950
 32' ARIES Sloop. Double-ender by Tom Gilmer, F/G, dsl, bluewater cruiser... Asking 22,950
 30' STEEL Slocum's Spray replica by Roberts. Dsl, new, unfinished project.. 14,900/Offers
 30' TRIMARAN by Aynnaught. Folding, trailerable pocket cruiser. REDUCED. Asking 29,500
 24' MELGES class racer with trailer and outboard. Fast and fair Asking 17,950

50' TRUMPY TRAWLER, Long range, great layout, 671 N-Series diesel. Needs TLC. A great boat!..... 44,950/offers
 48' DUTCH CANAL Barge. Beautiful & comfortable Sausalito liveboard. Steel, diesel. MUST BE SEEN! Asking 219,000
 45' STEPHENS 1929 classic. Beautiful Gatsby-era motoryacht waiting to transport you back to the days of yachting in the grand style..... Try 75,000
43' CLASSIC EXPRESS CRUISER By CALLIS. Total & magnificent professional restoration. Beautiful, stunning, ALL VARNISHED TEAK 1923 head-turner, copper riveted, tasteful & completely modernized & updated systems. MANDARIN is a fascinating history & is an important part of the West Coast Yachting tradition. Now **VASTLY REDUCED** to a fraction of her restoration cost! **MUST SELL NOW!** Asking 98,950

43' MATTHEWS, '65, diesel. A gem! Loaded and beautiful..... Asking 69,450
 42' GRAND BANKS Tvl. Aft cabin, F/B, Onan, twin dsls, radar. Excellent..... 121,000
 36' SEA RAY 360 aft cabin fly bridge express. Twins. Nice & a GREAT VALUE. Asking 34,950
 34' CLASSIC LAKE UNION DREAMBOAT. We have TWO; a Blanchard and a Rathfon. Starting at a BARGAIN 17,500 Asking
 28' BAYLINER 2850 FLYBRIDGE SEDAN. New VOLVO/GM 300hp V8, economical & 30+MPH reported. Just completely refurbished & refitted to exceptional condition Asking 19,950
 27' FARALLON Pilothouse, '86. F/G, twin 5L V8s, fast and seaworthy. Just detailed and very nice Asking 51,950
 22' ALUMINUM PLEASURE TUG. Bufflehead live/cruise. Loaded..... Asking 108,250



GREAT PROJECT BOAT
43' NEW ZEALAND-BUILT CENTER COCKPIT ENDEAN YAWL Diesel, wheel, binnacle, dodger, cabin heater, great layout and more! Vessel requires significant work but will be an outstanding cruising boat when completed. MUST SEE! SHE'S A BARGAIN! Asking **\$24,950**/Offers



OFFERS INVITED
57' BOWMAN Ketch. An AWESOME vessel completely equipped for world cruising. TOO MUCH TO LIST; must be seen. Has circumnavigated and also completed the Northwest Passage east to west. Seaworthy, comfortable and roomy, this is your ultimate bluewater cruising yacht. Asking **\$219,950**



GO ANYWHERE
44' STEEL Canoe-stern cutter by Geo. Buhler/Fred Lagier & Sons. John Deere diesel. Stout steel construction. Awesome bluewater cruiser built to go to sea and stay there. Radar, GPS, etc. Here's your world beater! Asking **\$89,995**



SELL NOW!
49' CUSTOM Cold-Molded Ketch by Reliant. Beautiful Hankerson design. Powerful and seaworthy bluewater cruiser in great shape. Built '91. Yanmar diesel, furling, self-tailers, aux. genset, full galley, full electronics and MORE! MUST BE SEEN. Asking **\$119,950**

CALL (510) 232-7200 OR FREE (877) 444-5087
OR CALL GLENN DIRECT AT (415) 637-1181
FOR INFORMATION & INSPECTION APPOINTMENTS



**Your Complete Maritime
Service Centers**

PT RICHMOND

services including:

**ENGINE SERVICE
ELECTRICAL
RIGGING
& MORE**

SAUSALITO

now scheduling for:

**BOTTOM WORK
FIBERGLASS
PAINTING
WELDING**

3 Seminars scheduled!
Rigging, Electrical &
Diesel Engine Maintenance
this October in the KKMI
Boathouse in Pt. Richmond
Call (510) 235-5564 or visit
kkmi.com as seminars will fill up!

"Thanks to the whole KKMI team for the fantastic job they did on our Mason 44, 'Arione'. From our first contact, when Art called at 7am from somewhere off the Oregon coast, we felt confident that KKMI was going to get everything working, and you did. We're now on our way to the Baja Ha-Ha with renewed confidence in our new systems. Thanks so much!"
Jaye Eldridge & Art Stiers

KKMI Richmond, 530 W. Cutting Blvd., Pt. Richmond, CA 94804 (510) 235-KKMI (5564)
KKMI Sausalito, 420 Harbor Drive, Sausalito, CA 94965 (415) 332-KKMI (5564)
www.KKMI.com for yard info, rates & more about KKMI Pt. Richmond & KKMI Sausalito