

Latitude 38

VOLUME 399 September 2010

WE GO WHERE THE WIND BLOWS

Latitude 38

SEPTEMBER 2010

VOLUME 399

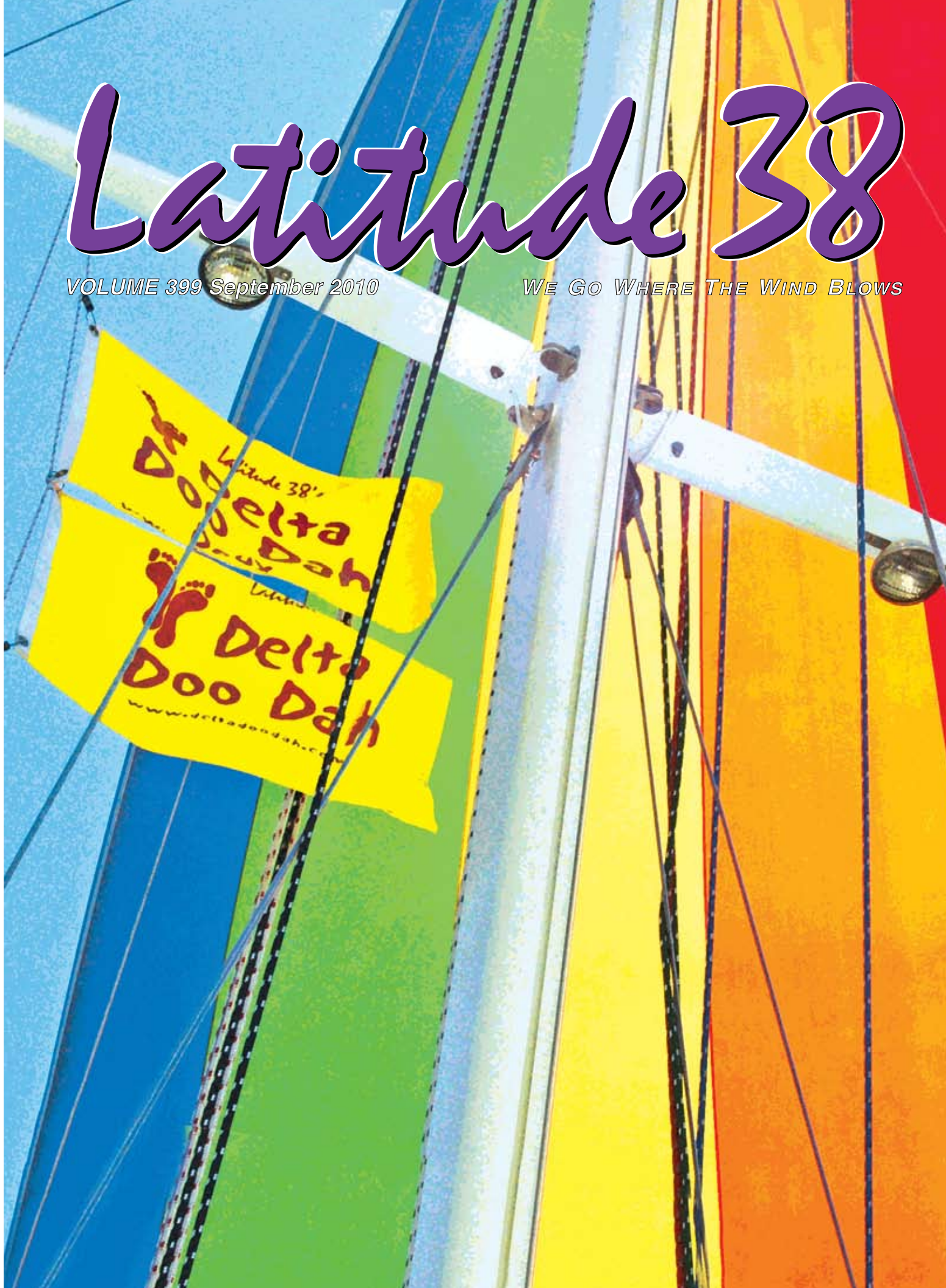

DELTA DOO DAH

This summer may well come to be known as 'The Summer That Never Was'. Bay sailors are accustomed to the biting winds so typical of summer here, but this year they were less than thrilled with a persistent marine layer that hid the sun behind a veil of gray for most of the month of July, as well as much of August. In fact, according to the National Weather Service, this July was San Francisco's coolest since 1971, with an average daily high of 63 degrees (the average July high is 72). So it was with great anticipation that the participants in the second annual Delta Doo Dah — aka, Delta Doo Dah Deux — prepared themselves and their boats for a week of basking in the Delta sun.

Thought up over a bottle of wine at the company Christmas party, the Doo Dah was intended to encourage folks to explore their own backyard. Considering the entry fee was just \$49 — which included a T-shirt, burgee and swag bag, not to mention free moorage at three marinas or yacht clubs — we assumed the inaugural event's 30-boat entry list would fill up fast after registration opened on *Lectronic Latitude*, but we were surprised that it took only two days. Clearly folks were looking for a good excuse to use their boats, and we intended to show them a good time. By all accounts, that first Doo Dah exceeded everyone's expectations, and we all looked forward to a repeat performance.

Since the response was so tremendous last year, we increased the entry list to 50 for the Deux, while keeping the low entry fee, in hopes of accommodating everyone who wanted to join. With 20 more slots, we figured it might take an extra day to fill the list. Imagine our surprise when, after opening registration on March 15, we were 'sold out' within 12 hours!

Little did these eager sailors know, come July, just how eager they would be for the Doo Dah to start.

While the official start of the event was the following morning, most of the fleet gathered at Tradewinds Sailing School & Club in Richmond on Friday, July 30, for a potluck-cum-skippers' meeting. Some came by car, but many boats started their trip a little early by descending on event sponsor Marina Bay

Yacht Harbor. As the crowd huddled on Tradewinds' sheltered patio, Doo Dah'ers got a chance to see just what they'd be missing — or, rather, *not* missing — over the following week: biting winds and gray skies. "Welcome to Marina Bay, where it's always this warm," joked Harbormaster Steve Orosz.

So many delicious dishes — paella, fruit salad, enchiladas, brownies, pie

— were heaped onto the lone potluck table that another had to be put into service. The wine and beer fellow Doo Dah'ers brought to the party helped loosen tongues for the introduction portion of the evening, before 'Doodettes' Christine Weaver and yours truly ended the festivities with prizes from Trinitas Cellars, Little Venice YC and Glen Cove Marina. "You should probably know,"

ALL PHOTOS LATITUDE / DOODETTE LADONNA UNLESS NOTED



GARY RYAN



ERIK JONES



BETTY ADAMS

The inspiration for the Doo Dah logo.

after opening registration on March 15, we were 'sold out' within 12 hours!



— HERE COMES THE SUN

Christine announced, "that next week's forecast for the Delta is 85 degrees and 15 knots — every single day."

The crowd roared.

Walking the docks the next morning, we saw more than one sailor decked out in full foul weather gear. "The guys are all making fun of me," said one such dressed up gal, "but I'm just gonna laugh when they're freezing their butts off out

there!"

One thing's certain: while her precaution wasn't in vain, it wasn't necessary for long. Almost as soon as the fleet sailed under the Richmond Bridge around 11 a.m., the fog gave way to sun and 15 knots out of the south, making for a fantastic broad reach up San Pablo Bay.

The relief the 120 or so dreary-weary Doo Dah'ers felt upon leaving the gray

behind was evidenced by happy chatter on the event's working channel. "I want to thank the 'Doodettes' for a beautiful sail," chimed one voice. "Yeah, I'm finally stripped down to my shorts," said another. But the highlight of the gaiety was instigated by 10-year-old Elani Cassero of the Hunter 30 *Volaré* when she started a G-rated joke-telling session. "I don't think I've ever heard sailors tell such clean jokes," noted Doo Dah vet Adam Correa from the Santa Cruz 27 *Bozo*.



DANA MELLON MAJORS



Doo Dah Debauchery — (top row, l to r) The kids from 'Petite Sirah' and 'Bayeti' were deadly foes in battle; Potato Slough at sunset; "Again!" two-year-old Tyler Mellon Majors cried after being dropped off the Catalina 320 'La Vida' to the waiting arms of Uncle David; 'Moor'ea' barrelled through the fleet in an effort to quickly leave the fog behind; (middle row) Brian Jones isn't quite sure what to make of husband Erik's PDA; Valencio Grygier played the joker; beach party fun at Franks Tract; (bottom row) Sundowner time aboard the Catalina 42 'Neener'; 'Doo Dog' Tess from the Rawson 30 'Dora' played a mean game of fetch; Ben Mewes and Ed Dietz duke it out in dinghies; Mycah Landes paddles her stress away.



DELTA DOO DAH

Thanks to a strong flood that lasted all day, boats reached their destinations quickly. Some broke off for Benicia or Glen Cove, while others took advantage of their speed to make it closer to Pittsburg Marina, site of Sunday's Welcome to the Delta Party.

“These are the most beautiful bathrooms I’ve ever seen,” Katherine Smith of the Pearson 35 *Carousel* gushed about Pittsburg Marina’s facilities. In fact, the marina recently completed a total revamp, including beautifully appointed heads. Once too silted-in for easy keelboat access, the marina was recently dredged, which allowed every boat in the fleet to make it in, even at low tide — though the deep drafters, such as Ben and Lucie Mewes’s Van de Stadt 41 *Georgia*, which draws nearly eight feet, may have left the next day with a little less paint on the bottom of their keels.

As boats trickled in throughout the day — while dodging moving targets in a high-speed waterskiing competition that was taking place just outside the marina on New York Slough — folks acclimated themselves to the warm weather by taking to the water. Stand-up paddle boards (SUPs), dinghies, and water cannons were broken out and put to good use.

Soon the rockin’ sounds of the Mike Osborn Band drew the group to the *Island Serenade*, the cruise boat belonging to party hosts Steve and Heather Ingram of Delta Discovery Cruises.

Eating, dancing, and drinking — not necessarily in that order — ensued, culminating in a second round of prize-giving, including gift certificates to Owl Harbor Marina. But even though the party was over, the socializing continued between boats late into the night.

The next morning saw a veritable exodus out of the marina as boats made their way to Bethel Island, the next stop. “I don’t know why they’re all in such a hurry,” commented Nate Oleson of the Catalina 36 *Lady Jane* as he watched the parade pass him by. “I think we’ll stick around a little while to enjoy the nice accommodations.”

Another day of spectacular sailing conditions inspired a handful of boats — the Ericson 29 *Moor’ea*, the Mariner 31 *Gitana Vela*, and the Ranger 23 *Rigel*



The official 'Voice of the Doo Dah Deux', Lucie Mewes.



— to take the 'long way' around Franks Tract, while the rest of the fleet made their way to tiny Boyd's Harbor. There, Bethel Island resident — and its loudest cheerleader — Peter Yates shoehorned everyone in with apparent ease. “We moved a few permanent boats out to anchor in Franks Tract to make room,” explained Peter.

In fact, four five-boat-deep raft-ups formed to accommodate the fleet — 47 boats, in all. For a number of partici-

pants, this was a very new experience. “We’ve never rafted up before,” Linda Stafford of the Catalina 375 *Hotel California* said — with only the slightest hint of nervousness — as we readied to throw her our lines.

In addition to marshalling the fleet into the massive raft-up, Peter, as he had done last year, organized a beach party across Franks Tract, where Doo



Doo Dah Debauchery — (top row, l to r) Whisker pole diving at its finest; skurfing on a SUP; the fleet crammed in like sardines at Boyd's Harbor; Katherine from 'Carousel', Peter Yates, and Katherine Anderson enjoyed the beach party as much as anyone; (middle row) Alisa and John Cassero from 'Volare' jumped for joy when they won the Ronstan Air Arch; if Brian Forster of the Newport 30 Mk II 'No Agenda' looks familiar, it's probably because you were a 'Partridge Family' fan — he played Chris; a dinghy racer gets ambushed at the finish line; 'Flibbertigibbet's Jim Adams tears across the race course; (bottom row) the girls try to lure the boys off the fun Jet Ski but the boys aren't having it; Jay and Mycah throw da shaka while Maceo stands watch; Wayne and Karen Edney spent 10 years building their gorgeous Bristol Channel Cutter 'Odyssey'; Wha'SUP? The boys battled to keep each other off the board.



Dah'ers enjoyed Jet Skis, SUPs, a Hobie cat, and sundry water toys. Peter's fiancée Katherine Anderson played hostess, providing everyone with refreshments and snacks.

The day ended with a fantastic tri tip buffet laid out by Kim and Rob Brunham, owners of The Rusty Porthole, followed by a karaoke jam session with Peter and friends.

Each morning, Doo Dah'ers were treated to the 'Voice of the Doo Dah', Lucie Mewes, cheerily leading the daily net. Tuesday morning was especially busy with folks announcing their plans for the upcoming three free days, when participants get to choose their own adventure. The fleet broke up with different groups heading to Mildred Island, Walnut Grove, and Potato Slough, and a number of boats exploring on their own.

Some moved daily, others were content to simply sit in one spot, doing little more than picking blackberries, racing dinghies, hosting sundowners, or picking waterfights in which the kids from the Islander 36 *Petite Sirah* and the Islander 30 *Bayeti* soundly defeated their much-older foes (ouch!).

Friday morning — the final day of the rally — came all too soon, with that day's net concluding with bittersweet thanks to all the participants, organizers, and

DELTA DOO DAH

sponsors. Doo Dah'ers scattered across the Delta chimed in about how much they had enjoyed their week away from the oppressive fog of the Bay, and how much they were looking forward to the Doo Dah Hoopla Party at Stockton Sailing Club, while at the same time wishing it would never end.

But what a way go out!

Stockton SC — famous for its hospitality — once again hosted the fleet, and once again impressed everyone with their generosity. Not only did they provide shuttle service to the grocery store and West Marine, but also offered up their dinghy fleet for some lighthearted racing. 'Doodette' Christine and her skipper, Jonathan Guttoff, organized the races between FJs, El Toros, and Opti-like prams — "It was a simple upwind-downwind; what we call a 'single sausage'," Christine said — offering *Latitude 38* hats to everyone who started. That simple bribe brought out 17 eager racers who gave every indication of having a total blast.

"I haven't sailed an El Toro in de-



TOM PRICE

Tom Price hosted three wounded vets aboard his Beneteau 473 'Vitesse'.

cares," hollered Richard Schaper of the Catalina 30 *Ebenezer II* as he scooted by. "I haven't had so much fun either!" He must not have been lying, as he turned around for a second lap after finishing first in his class.

As soon as the racers returned to the dock, their noses dragged them up to the pavilion where the club had laid out its always-scrumptious BBQ dinner. Before the classic rock band Last Call got every-

one on their feet, we Doodettes doled out the remaining prizes, including items from Sol Light, Port Visors, Shockles, and the much-coveted inflatable boom tent from Ronstan — which had been thoroughly tested aboard one 'committee boat' for the duration of the Doo Dah (see www.deltadoodah.com/sponsors for the full list of prizes).

During one late-night jam session on Potato Slough, someone suggested writing a Doo Dah anthem, one that perfectly described the event and its effect on the fleet. A few songs later, we realized that George Harrison had already done it for us:

Little darling, the smiles returning to the faces

Little darling, it seems like years since it's been here

Here comes the sun

Here comes the sun

And I say, it's all right

— **latitude /ladonna**

Owl Harbor MARINA

Beautiful 20 acre greenbelt park in the Heart of the Delta

- Up to 30' no power/inside tie @ \$4.50 per foot
- 30'- 50' berths @ \$5.50 per foot
- Home of Andreas Cove Yacht Club

Located on Seven Mile Slough, just off the San Joaquin River

1550 W. Twitchell Island Road • Isleton, CA 95641
916.777.6055 • www.owlharbor.com

OFFICIAL SPONSOR OF

Latitude 38's
Delta Doo Dah 2
July 31 - August 6

You're invited to...

Drop Anchor at the Pittsburg Marina!



- NEW GUEST DOCKS
- NEW FUEL DOCKS
- Valvtect Marine Fuels



OFFICIAL SPONSOR

Call us at
(925) 439-4958

or visit us at
www.pittsburgmarina.com
51 Marina Blvd. ~ Suite E
Pittsburg, CA 94565



- Saturday Farmer's Market in the summer
- Delta Discovery Cruises
- Delta View Golf Course
- Many nearby restaurants



VALLEJO MARINA



Gateway to the Bay & Delta

JOIN US FOR THOSE WARM SUMMER NIGHTS!

- Competitive Rates!
- Ample Guest Dock
- Full Service Boat Yard and Chandlery
- 2 Restaurants for Breakfast, Lunch, Cocktails and Dinner
- Covered and Open Berths



(707) 648-4370 • Fax (707) 648-4660

42 Harbor Way • Vallejo, CA 94590

www.ci.vallejo.ca.us marina@ci.vallejo.ca.us

FULL SERVICE MOBILE RIGGING

- *Competitive Rates*
- *Firm labor quotes on most projects*
- *17 years experience*



Call John Hansen



Alameda
(510)815-4420

yachtcheck@yahoo.com

LITTLE BOATS,

For many years we at *Latitude* have been trying to pound home the importance of being ultra safety conscious when riding in a dinghy. We were initially motivated by something like six people being killed in a horrific two-dinghy accident in the Caribbean in the '80s. Then, about 15 years ago, the owner of a Long Beach-based Bowman 57 was killed by a panga in a hit and run accident at Punta Mita, Mexico. Our concern grew a few

"The main bones in both my arms had 90-degree breaks and were attached to my body by little more than skin."

years ago when a couple riding their slow dinghy into the harbor at Gustavia, St. Barth, to celebrate their just-completed circumnavigation, were overtaken by the Kiwi skipper of a megayacht operating a big inflatable at high speed. If memory serves us, the man in the smaller dinghy was killed and his wife lost her leg.

While he wasn't in his own dinghy when the accident happened, Max de Ram, a Swiss sailor for whom a Northern California friend often crewed in the South Pacific, was severely injured in another dinghy accident. De Ram was swimming near his just shaken down Gunboat 66 cat at an anchorage off Corsica when he was almost hit by some Italians in a dinghy. When the dinghy operator threw the engine into reverse to get farther away, it sucked de Ram's arms into the spinning prop. De Ram suffered such severe damage to his arms

and other parts of his body that he was in the hospital for months. The 70 year-old lifelong sailor is still alive, but he's a shadow of his once-vibrant self, and had to sell his catamaran.

The victim of the most recent dinghy tragedy we have to report is 59-year-old Giles Finlayson of Encinitas, who was severely injured and nearly killed off Langkawi, the popular island stop for cruisers off the west coast of Peninsular Malaysia. The terrible accident happened in late December, in the fourth year of Finlayson's sailing/surfing safari aboard his Newport 41 *Petrel*.

The son of prolific actor, director and writer Robert Douglas — who dropped his last name for professional purposes at the urging of studio chief Jack Warner — Giles remembers Elizabeth Taylor coming over to swim nude in their pool every week, and was pushed into surfing by Rex Harrison in front of the actor's Malibu home. But instead of 'going Hollywood', Finlayson became a Southern California all-around waterman, enjoying surfing, sailing, diving and paddleboarding along the coast and out at the Channel Islands. He not only paddleboarded from Catalina to Manhattan Beach 10 times in the Catalina Classic, but also four times from the Isthmus to Point Vicente in another competition, and yet another three times on his own. His best time in the Classic was 5 hours and 59 minutes. "I've been in tune with the ocean my whole life," he says.

Finlayson worked as a contractor on a lot of big custom homes in Malibu

and Los Angeles, and eventually bought a Newport 41. While he's owned his Newport 41 for 20 years, he didn't catch the cruising bug until '03. He got the bug at a most unusual time — while doing a Baja Bash aboard Dennis Conner's R/P 47 *Stars & Stripes* following the '03 Puerto Vallarta Race. As a result of seeing the light on the Bash, Finlayson committed himself to going on a long sailing/surfing safari.

To quickly summarize Finlayson's sailing adventures to date, almost all of which have been singlehanded, he departed for Mexico in the fall of '05, and in the spring of '06 started his 27-day passage to the Marquesas. He spent Christmas of '07 in Tahiti and Christmas of '08 in Australia — where he'd been thinking about immigrating until he found out more about all the dangers lurking in the waters of northern Queensland. After doing the Sail Indonesia Rally, followed by the Sail Malaysia Rally in '09, he spent Christmas of '09 at Langkawi, Malaysia.

In one of the strangest coincidences we've heard of, as part of the Sail Malaysia Rally, Finlayson, who isn't the biggest group kind of guy, joined a tour of the Loh Guan Lye Specialist Centre, which is a hospital in the Malaysian megalopolis of Penang. He and other rally members were given a tour of the upper floor Presidential Suite of the hospital. "If I ever need treatment," Finlayson jokingly told one of the members of the group, "this is where I'm going to come." It was harrowingly prescient, for three weeks later, on December 27, Finlayson was the victim of a terrible accident that would result in his spending close to four weeks recuperating in that very Presidential Suite.

ALL PHOTOS LATITUDE/RICHARD



By coincidence, the Wanderer was in Langkawai two weeks after 'Finlayson' was run down. He took this photo of a typical Malaysian fishing boat in the same spot where Finlayson and a fellow cruiser were run over and left for dead, apparently to the dismay of none of the local law enforcement.





to keep his head above water. It was then that I realized that he had no use of his arms. With Giles kicking his legs, I managed to get him back to the dinghy and pull him in. I then called to the offending boat for help, but the skipper, who was wearing a white hat or turban, just motored away at speed.”

Fortunately, another fishing boat came along and towed Giles and Geoff — still in Geoff’s dinghy — the short distance back to the fuel dock. A Canadian doctor on a cruising boat administered first aid to try to stop the bleeding. An unconscious Finlayson was then taken to the local clinic in Langkawi, where the staff decided that his injuries were beyond their capabilities. He was put on a small ferry and taken to a Muslim government hospital in Kedah, the state capital of Alor Setar. Finlayson did not have the best experi-

During an interview aboard *Profligate* last month, Finlayson told *Latitude* about the accident.

“Longtime Perth sailmaker Geoffrey Moore of the Adams 42 *Beach House on the Moon* and I had just filled our 10 jury jugs with gas and diesel at the fuel dock at Telaga Harbour — which is an imitation Med harbor and marina protected by two big artificial islands — and put them in the dinghy. It was about 3 p.m., and we began to motor out the narrow entrance channel. Before we passed the lighthouse at the end of the channel, I sensed that Geoffrey had suddenly sped up, so I looked down at his hand on the throttle. As I did, the bow of what I would later learn was a 30-ft wooden fishing boat doing 20 knots, suddenly came into my field of vision.

“I instinctively covered my head with my arms and tried to bail out of the dinghy. But there wasn’t time. The next thing I knew, both of my arms had been severely injured by the prop. The main bones in both arms had 90-degree breaks, and both arms were connected to

Although Finlayson is all too familiar with how one’s life can change in an instant, he can still smile and considers himself lucky.

my body by little more than skin. There was blood everywhere, and in my dazed state of mind I assumed that I was going to die. Just before losing consciousness, I saw that the fishing boat had stopped about 150 feet farther along. I was later told that Moore repeatedly yelled at the man to come and help, but he simply took off in the other direction. Nonetheless, I’m a walking miracle, because it was truly miraculous that Geoff was able to get me back into the dinghy before I drowned.”

In writing about the incident, long time cruiser Fred Roswold of the Seattle-based *Serendipity 43 Wings* quotes Moore as follows: “I saw Giles in a pool of bloody water and gasping to stay afloat. I dove into the water and swam to him

ence there.

“Among other things, the bones in my arms weren’t properly aligned, so they subsequently couldn’t heal, not all of the screws were put into one of the plates attached to the bone, and one of the screws for the plates was interfering with a nerve. And despite my calls for water that night, none of the nurses would bring me any. When the doctor visited me the morning after the opera-

Telaga Harbour, an imitation Med-like marina, located at Langkawi, Peninsular Malaysia. This photo was taken from the fuel dock.



LITTLE BOATS,

tion on my arms, he was surprised to see a pool of my blood on the floor. He told me I needed a transfusion.”

Finlayson was then transferred to the Loh Guan Lye Specialist Centre in the big city of Penang, and put in the very Presidential Suite he'd visited on the tour a

"They didn't have cutting edge technology, but it was beautiful how they cared for me."

short time before. "I was in such terrible condition upon arrival that they made me put my thumbprint to a document that said they wouldn't be responsible if I died. But the people at that hospital, who represented a variety of religions, were absolutely fantastic. They may not have had the cutting edge technology we have here in the States, but there were three or four people with me at all times, and they did their very best with what they had. It was just beautiful how they cared for me, particularly Nora Beh, an executive at the hospital who had guided the tour I'd taken several weeks before."

After a month stay in the hospital, Finlayson was offered the free use of a magnificent penthouse by Mr. Oh Kean Shen — 'Mr. O' — a wealthy Malaysian who owns, in addition to a bank and other stuff, a large shipyard that serves the huge Malaysian fishing fleet, the Malaysian Navy and the Malaysian Coast Guard. Out of the goodness of his heart, Mr. O stopped by the hospital three times to see how Finlayson was doing, and was about the only one who tried to get Malaysian authorities to catch the

So far eight screws and one plate — see penny for size reference — have been removed from Finlayson's arm. But the fix-it work isn't done.



perpetrator.

Ultimately, Finlayson declined Mr. O's generous offer of the penthouse, because he didn't want to be stuck in a huge city where he didn't have many friends, particularly in his very weakened condition. So for a month Finlayson took up residence in a \$100/night waterfront room at the five-star resort at Rebak Island, Langkawi, just a few miles from the site of the accident. Finlayson says that Samir, the manager of the hotel, and his staff couldn't have been more kind or helpful. "The people there were the nicest people in the world." In addition, he was visited frequently by Moore, and given much care by Helen MacKinnon, Moore's girlfriend. Another benefit of the location is that it has a boatyard popular with world cruisers. Friends brought *Petrel* to the yard, where she remains hauled out today.

Finlayson arrived back in the United States on April 1 thanks to the help of many friends. Mike Perry, an American living in Australia, J.P. Cruise, a paddleboarder/surfer/sailor from Manhattan Beach, and Leslie Baron were three of the most instrumental in raising enough money to bring Finlayson back to the States, and to fly Paul Parizeau, a racer out of the San Diego YC, down to Malaysia to accompany him back. He was in no condition to carry his X-rays, let alone his baggage.

Since his return and getting set up at his home in Encinitas, Finlayson has been seeing Dr. Nicholas Rose, a hand and arm specialist in Newport Beach, to try to undo the damage done at the first hospital in Malaysia. When Finlayson visited with us aboard *Profligate* in San Diego in mid-July, he'd had a total of three operations, and was slated to have another so he could close the fingers on his right hand. "My advice to anyone with serious injuries such as mine is to try to get back to the States for medical care. If you have a relatively simple medical issue — such as a gall bladder problem — it's not a big deal in the Third World, but for complicated medical problems, I think the U.S. has the best doctors."

When we saw Finlayson in July, he had limited use of his



hands and arms. He told us that he'd tried swimming twice, but couldn't yet fully extend one arm, and wasn't able to close the fingers of his right hand. In addition, both his arms are extremely weak. He goes to the gym regularly, but so far his doctor has limited him to 10-pound weights. For a guy used to going up and down his mast by himself, and paddling 32 miles across the Catalina Channel, it's been very difficult to accept his injuries. But to use one of Giles's favorite expressions according to the gang at Two Harbors, "It's going to take a bullet to stop me."

Mental health is, of course, just as important as physical health. Finlayson says he relives the accident every day, and he understandably has some good days and some bad days. But generally speaking, he's just thankful to be alive and have the care and concern of friends. His ultimate goal — as one would expect

— BIG IMPACT



We love the panganeros of Mexico, but sometimes they operate their boats at reckless speeds. If the panga's high bow keeps you from seeing the driver, you know he can't see you either.

of a consummate waterman — is to get back to his boat and resume the cruising he loved so much. As such, his limited exercise regimen includes pulling on lines, as he will have to do with halyards if he can resume cruising. Despite the prospect of a long period of recovery, Finlayson is optimistic and determined — although he acknowledges he may have to cruise with crew.

Just prior to going to press, we spoke with Finlayson again, and learned he'd had another operation a few days before. "Dr. Rose realigned my radius bone — which had been snapped in half in the accident — on my right arm and put in a new titanium plate. The bone had never healed because it hadn't been properly aligned, and they'd put the plate in crooked without enough screws. The old hardware had been riding on the ulnar nerve, which prevented me from being able to close the fingers on my

right hand. But now I can grab things with my right hand again! It's incredible news. When I told Dr. Rose the next day, he just started laughing with joy.

"Being able to close the fingers on your hand may not seem that important to some, but if you're a swimmer or paddleboarder or sailor, it's critical," says Finlayson. "I have so much to be thankful for. I'm so lucky. It's going to take about a year for my right arm to heal again completely, at which time I hope to have 80 to 90% of normal use. I'm cautiously optimistic."

The trouble with Finlayson's left arm is a problem with the elbow that prevents him from being able to stretch it out all the way. "When I stretch, my left arm is three inches shorter than my right arm. It results in major limitations, so Dr. Rose is thinking about operating on it in December. My hope and goal is to be able to singlehand again, but I'll just have to see. Every day is a new day, and I do what I can to get exercise. After all, I

know that I'll need every ounce of muscle if I'm to singlehand again."

According to *Wings'* Fred Roswold, Finlayson is not the only cruiser to be a victim of a hit and run in Malaysian waters. Roswold reports that the crew of the yacht *Bara* were run down by an outboard-powered tour boat while traveling in their dinghy off the Hole in the Wall Restaurant near Langkawi. That accident was witnessed by a local businessman, who identified the operator of the tour boat that fled the scene. Restitution was paid.

Roswold also reports that Joel and Christian — no last names available — of the yacht *Maeva* reported being hit on two separate occasions while in their dinghy by boats traveling at high speed. They now carry — and wave — a giant Malaysian flag whenever they are in their dinghy and are approached by a fast boat. While neither Joel nor Christian was injured in the two incidents, their Zodiac inflatable and their outboard were destroyed. In the one case, the tour operator acknowledged his company's responsibility and paid for some, if not all, of the damages.

The consular staff at the U.S. Embassy in Kuala Lumpur told Finlayson that there was another American cruiser who had been the victim of an on-the-water hit and run. The embassy wouldn't provide the sailor's name, but on May 25 of last year, the *Bangkok Post* reported that Kenneth Wayne, a 63-year-old American sailor, had gone missing off the east coast of Malaysia after his boat had been hit by an unknown vessel. For what it's worth, in general the U.S. embassy in

Giles hopes not only to be able to fully extend his left arm, but also to regain enough use of both arms to continue on around the world.



LITTLE BOATS, BIG IMPACT

Malaysia wasn't particularly helpful to Finlayson. For example, they promised to visit him on several occasions, but never did.

After Finlayson's accident, Moore filed a police report on his behalf and provided a detailed description of the operator of the vessel and the boat. But life is cheap in that part of the world, so the authorities don't seem particularly motivated. Besides, there are 10,000 fishing boats in Malaysia, and most of them look similar to the one that hit Finlayson. The authorities at Langkawi did hold at least one public meeting with tour operators to highlight the problem. Concern was expressed, but Roswold doesn't think much if anything has changed.

"Operators of the fishing and tour boats in Malaysian waters still get little in the way of training, licensing or supervision. On-the-water law enforcement



The famous 'long-tail' boats of Thailand are notorious for being loud — and being operated in a reckless manner. Watch out!

is notably absent. The Telaga Harbour waterway where Finlayson was hit still doesn't have a posted speed limit. So the situation for cruising yachtsmen riding in their dinghies in Malaysia remains dangerous. One must also suspect that the same is true in Thailand, where the many high-speed long-tail boats would be just as dangerous."

But we at *Latitude* must remind all sailors that terrible dinghy accidents aren't limited to Southeast Asia. They happen all over the world, and because they often happen in resort or vacation areas, they usually aren't well-publicized.

You simply cannot count on anyone but yourself to watch out for your safety, no matter if you're in a dinghy off Mexico, Morocco or Malaysia. Since you're always vulnerable in a dinghy, you must constantly be on the alert for developing threats. It's not that hard, but you have to be vigilant. And if you're in your dinghy at night, make sure it's well lit, and keep your eyes peeled for unlit boats and dinghies being recklessly operated at high speed, for they are everywhere. As has been tragically proven too many times, they can maim or kill you.

— **latitude**/rs

Celebrate the Boating Lifestyle!



Discover

Brisbane
Marina



GREAT LOCATION! Just minutes to Central Bay sailing.

GREAT RATES! Starting at \$5.90/foot!

MARINA GREEN with picnic/BBQ areas, Bay Trail Access and FREE Wi-Fi.

**HOME OF THE
SIERRA POINT YACHT CLUB**



From Hwy 101, take the Sierra Point Pkwy exit and follow the signs to the marina.

**400 Sierra Point Parkway
Brisbane, CA 94005**

(650) 583-6975

www.ci.brisbane.ca.us

harbormaster@ci.brisbane.ca.us

LOCH LOMOND MARINA

**Slips Available:
62-ft, 53-ft, 46-ft
and 40-ft**

**Completely Rebuilt Marina • Gas & Diesel Fuel Dock • Free Pump Out Station
Modern Launch Ramp • Guest Slips Available • Marine Mechanical Boat Repair
Arena Marine Supply Store • Andy's Local Market • Bait Shop
Land or Sea Canvas • Windjammer Yacht Sales • Loch Lomond Yacht Club**

110 Loch Lomond Drive, San Rafael, CA 94901

Phone: (415) 454-7228 • Fax: (415) 454-6154

www.lochlomondmarina.com

Harbor Master – Pat Lopez • pat@lochlomondmarina.com



2010 MODEL CLEARANCE

Reliable in Mexico... And Everywhere!



Our 2010 Model Clearance is your best chance to get a great price on a reliable outboard for Mexico.

Tune-ups and spares too...



Engine Service Center

Auxiliary and outboard repair, upgrade & service. Be ready for the season!

POWERED BY

**HONDA
MARINE**



© 2010 American Honda Motor Co., Inc.
Always wear a personal flotation device while boating and read your owner's manual.
5-year warranty standard on all new Honda outboard engines purchased.
Check with participating dealers for complete details.

Limited Repos
Remain!

Outboard Motor Shop
Where the professionals shop!

(510) 533-9290

www.outboardmotorshop.com

333 Kennedy St., Oakland, CA 94606 • Fax 510-533-3374

THE RELIABILITY'S BUILT IN!

**HONDA
MARINE
PROVEN**

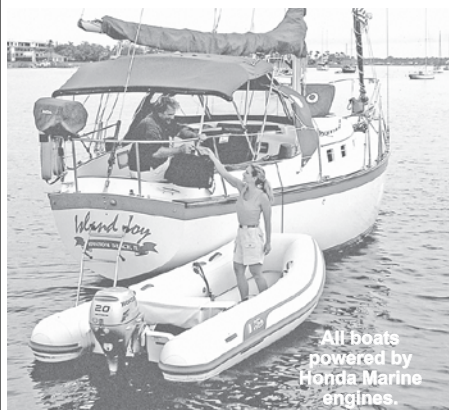

All boats powered by Honda Marine engines.



We offer complete service on all Honda outboards and inflatable boats and take pride in providing the kind of customer satisfaction that you expect from Honda.



The Dinghy Doctor
1271 Scott Street
San Diego, CA 92106
Tues-Sat, 9am-5pm
(619) 804-6921

www.thedinghydoctor.com

2 blocks
off Shelter
Island

BF20

- Unsurpassed fuel economy
- Shallow water drive
- Largest displacement in its class (21.4 CI)
- Hi Output alternator (12 amps)

AB, Achilles, Zodiac, Walker Bay, repair kits, engine parts, and everything you will need in Mexico.

Always wear a personal flotation device while boating and read your owner's manual.

FAST, ROWDY & FUN —

It takes most cruisers years of planning and preparation before they're ready to tackle a patch of ocean like the South Pacific. But when they finally do become psyched up and fully supplied, it's mighty tough to deter them from their long-anticipated travel plans. Per-



Michael and Gloria of 'Paikea Mist' celebrate crossing the equator — at 8 knots in 12-ft seas — with a cup of Mexican grog.

haps that's why — despite a struggling world economy and threats of a strong El Niño influence on South Pacific weather — more boats registered for our 2010 Pacific Puddle Jump Rally than any time in its 15-year history. The final tally: 217 boats from 19 countries!

As regular readers know, ever since *Latitude* editors coined the phrase Pacific Puddle Jump years ago, we've dedicated a lot of time, effort and ink to celebrating the annual springtime migration from the West Coast of the Americas to French Polynesia. Why? Because we think making that passage is a major accomplishment within the realm of sailing. If you were to circumnavigate via the tropics, this 3,000-mile crossing would be the longest stretch of open water you'd face where you had no chance of a stopover en route.

We should clarify that we use the word "rally" very loosely when referring to this international collection of boats and crews. Although the majority of them typically jump off for Polynesia from either Puerto Vallarta, Mexico, or Panama City, Panama, others leave from a variety of points along the West Coast — and it's pretty rare for even two boats to set sail on the same day. So, in contrast to more highly structured cruising rallies with specific schedules, where entrants pay a fee to be shepherded by a committee boat, the Puddle Jump Rally is merely a loose association of westbound crews who trade weather info and get to know each other along the way via HF radio

nets. Many never actually meet face to face until they arrive in the islands.

This year, after we worked out a sweet deal for fleet members with Papeete-based Tahiti Yacht Agents, new boats started signing up for the rally in droves. For a small fee, all fleet members got exemptions from having to post the normally required security "bonds" upon arrival. Plus, they got cleared in and out, and were allowed to buy fuel duty-free.

Shortly before the optimum springtime weather window opened up, we helped foster camaraderie within the fleet by hosting PPJ Kick-off Parties at the Vallarta YC (February 6) in Nuevo Vallarta's Paradise Village Resort, and at the Balboa YC in Panama City (March 6). Then in mid-June we joined forces with Tahiti Tourism and the Papeete Port Authority to welcome the fleet to Polynesia at the three-day Tahiti-Moorea Sailing Rendezvous (featured in our July issue).

So how did this year's crossing compare to previous years? Well, whether you blame it on El Niño, global warming, global cooling, the alignment of the stars and planets, or the Obama administration, the fact is that this year's crossing seemed to be a bit windier than usual with lumpier seas. And, of course, there were practically as many reactions to those conditions as there were boats in the fleet.

Some, who'd done a number of previous ocean crossings, thought this trip was relatively easy: "The passage was quicker than planned and easier than our prior passages," reported Bill and Sue Grun of the Colorado-based *J/160 Avante*. They set out from the Galapagos in mid-April. Others thought the confused seas whacking them from several directions — especially north of the equator — were going to drive them bonkers. "There were some rough days when just getting out of the berth was a chore," remembers Alex Viterbi of the California-based *Hylas 49 Terrapin Flyer*. He left from Cabo San Lucas in late April.

Of course, making generalizations about conditions in such a vast pool of water is about as useful as an empty can of Hinano beer.

But *generally*, boats crossing via the Galapagos seemed to have a smoother time of it this year.

Behan Gifford of the Washington-based *Stevens 47 Totem*, who stepped up early on to act as one of several de facto group leaders, summarized her family's

"We bobbed around in the doldrums, and screamed along in the trades."

crossing this way: "Overall, much of this passage was right out of the textbook. We left (out of Puerto Vallarta) with the evening land breeze and sailed our way offshore. Things broke, but nothing serious. We bobbed around in the doldrums, and screamed along in the trades. We reefed and unreefed countless times. In fact, my husband Jamie and our crew-

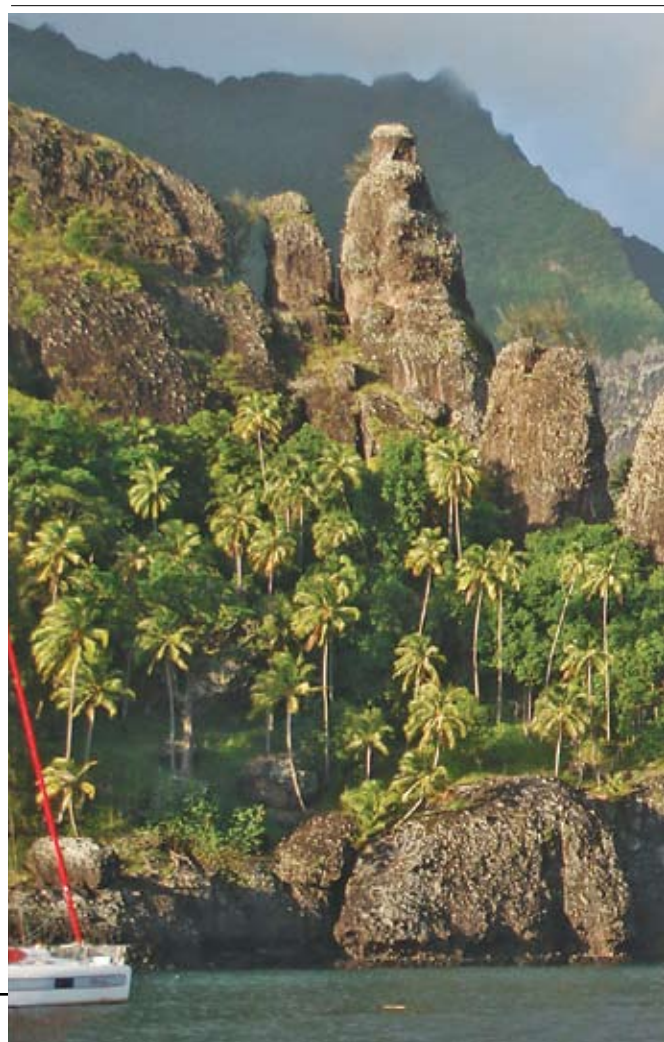

PACIFIC PUDDLE JUMP RECAP

man Ty were downright slaphappy when they wrestled with the reefing lines for the 12th time one afternoon."

One aspect of this year's crossing that was shockingly unique compared to previous years, was the number of emergencies. A severe crew injury led to a mid-ocean medevac, and two other fleet boats had to be abandoned at sea — all were 'firsts' in the Rally's history.

On April 1, while sailing in strong winds and big seas close to the exact middle of the passage, an accidental jibe aboard Rudy Heessels' Washington-based Beneteau First 36s7 *Wind Child* resulted in life-threatening injuries to crewman Michael Kalahar, 57. The colossal effort (detailed in our May issue) to save his life would inspire any red-blooded American to stand up and salute the stars and stripes. Like a scene out of

End of the rainbow indeed. We've run a lot of images of Fatu Hiva's Bay of Virgins before, but this one says it all.

The Perfect Storm, four specially trained Air National Guardsmen parachuted onto the scene in the dark of night from a long-range Coast Guard C-130. The parascuemen were able to stabilize Kalahar, then later transferred him to a Liberian-flagged container ship and stayed with him until they and their patient could be airlifted to a U.S. medical facility by a flock of four Marine Corps aircraft. We're happy to report that Kalahar is now A-okay.

On May 12, British skipper Robert William Marshall, 42, and his Taiwanese fiancée Yung-Ching Cheng, 29, were taken aboard a Belgian tanker after their Westsail 32 *Stray Dog* began sinking from unknown causes while en route to the Marquesas.

Six weeks later, long after successfully completing the Jump, newlyweds Louie van Praag, 36, an Australian, and his



American wife Alicia, 27, had to abandon *Tar Baby II* after dismasting near Niue. Ironically, she too was a sturdy Westsail 32. The young couple was picked up safely by a Taiwanese longliner.

As you'll see by the table on the following page, most of the fleet suffered breakage that's fairly typical: blown sails, uncooperative autopilots, broken gooseneck fittings, etc.

But at least two boats had to abort their crossings, and turn back to Mexico to make repairs. Jeff and Judy Wahl's Polynesian dreams were put on hold when their South Dakota-based Wellington 47 *Island Mistress* took on water that ruined essential gear. They returned safely to PV. Don and Marie Irvin had to turn back *twice*: "Both times we were close enough that it made sense," explains Don. Once they finally got going again in late April, though, their luck improved dramatically: They saw better weather than most boats that had departed before them, and made the crossing aboard their Hallberg-Rassy 46 *Freezing Rain* in 22 days.

As we've been told by hundreds of offshore sailors, a long ocean passage tends to be a blend of highs and lows. For most of this year's Puddle Jumpers, the lows were days in the doldrums with little or no wind, frightening squalls, and/or the simple monotony of day after day alone on the ocean. But the low point for Doug Schuch of the USVI-based Morgan 46 *Fellow Traveler* was when he was forced to make an unplanned pit stop at the Galapagos after his crew became



FAST, ROWDY & FUN —

anxious and wanted to get off. Undeterred, however, Doug completed the 3,000-mile leg from there to Polynesia's Gambier archipelago singlehanded.

For Bill and Kathi Cuffel of the Seattle-based J/42 *Jarana*, one of the lows was "having to fight off the booby birds that tried to land on the boat. The cheeky devils were very persistent and fought back!" says Kathi.

For Frank and Karen Taylor aboard the North Carolina-based St. Francis 50 cat *Tahina*, a definite low was noting how little marine life they saw offshore, then coming across "15 large Japanese fishing vessels line-fishing the heck out of the waters in grid patterns."

As Alex on *Terrapin Flyer* notes though, once a long passage has been



As Lori of 'Trim' can confirm, one chore that every passage-maker has to attend to before setting out is buying and storing provisions.

completed, "the high points are much more easily recalled: Each sunset was a time for celebration; the serene, sublime days of sunshine that blended into one another; and, of course, fresh sashimi."

The highs also make much better reading. Vince Wawrzynski of the San Diego-based Catalina 45 *Fidelis* recalls, "The high point came 300 miles west of the Galapagos when the tuna were biting everything I offered."

Gene Dennis and Gloria Watson of the San Carlos, Mexico-based Island Packet 44 *Pincoya* say, "The highest point for us was in the northern trades using our gennaker for six days and nights — a

2010 PACIFIC PUDDLE JUMP PASSAGE DATA

Although many more sailors did the Puddle Jump this year, those who responded to our questionnaire give a representative sampling of passage data.

Boat Name	Boat Make & Length	Captain & Crew	Boat's Homeport	Departed From / Date	Landfall & Date	Days Xing	Miles Xing	Eqtr X Long.	Engine Hours	Best 24 Hr	Worst 24 Hr	# Fish Cght	Breakage & Breakdowns
<i>A Cappella</i>	Valiant 42	Ed & Cornelia Gould	Half Moon Bay, CA	Galapagos 4/15	Hiva Oa 5/5	19	3,000	N/A	24 hrs	200	113	0	mainsail tear
<i>Alobar</i>	Island Packet 350	Joel Ungar	Santa Barbara	N/A	N/A	27	N/A	N/A	N/A	N/A	N/A	N/A	genoa tear
<i>Aphrodite</i>	Amel Maramu 46	Tom Deasy & Mary Ellen Mullane	Santa Cruz, CA	Puerto Vallarta 5/10	Hiva Oa, 5/31	21	2,974	130°	70 hrs	195	80	5	Ham/SSB problems; mainsail tear
<i>Avante</i>	J/160	Bill & Sue Grun	Telluride, CO	Galapagos 4/17	Hiva Oa 5/3	16	3,070	91°	6 hrs	240	150	6	generator impeller failed
<i>Bint al Khamseen</i>	Caliber 40	Ken & Susan FitzGerald	Seattle, WA	La Paz, MX 3/17	Hiva Oa 4/10	24	N/A	131°	141 hrs	155	N/A	0	blocks on wind vane system
<i>Delos</i>	Amel 53	Brian Trautman & Erin Russ	Seattle, WA	Mexico 3/26	Hiva Oa 4/21	18	2,900	130°	30 hrs	199	120	4	generator; propane hose broke
<i>Dignity</i>	Lagoon 41 cat	Helen & Steve Southwood	New York, NY	Galapagos 4/12	Fatu Hiva 5/3	21	2,984	N/A	N/A	195	80	4	blown light air sail
<i>Dream Caper</i>	F/P 42 cat	Portia Igarashi & Steven Stecher	Corte Madera, CA	Galapagos 4/17	Fatu Hiva 5/6	19	2,889	N/A	43 hrs	192	123	3	turnbuckle toggle; blown spinnny; etc
<i>Elixir</i>	F/P 42 cat	Dr Simon & Jane Elix	Darwin Australia	Puerto Vallarta 3/30	Nuku Hiva 4/19	20	2,800	129°	80 hrs	180	100	10	lost topping lift; freezer defrosted
<i>Fellow Traveler</i>	Morgan 46	Douglas Schuch	St John, USVI	Panama 3/16	Gambiers 4/18	33	3,816	88°	80 hrs	165	81	2	eng freeze plug & wtr pump failed
<i>Fidelis</i>	Catalina 45	Vince Wawrzynski	San Diego	Panama City 3/15	Nuku Hiva, 4/12	26	4,000	105°	8 hrs	211	130	10	lost a lure to a monster fish
<i>Fly Aweigh</i>	Catalina 45	Allan & Alison Gabel	Channel Islands, CA	Puerto Vallarta 3/23	Hiva Oa 4/14	22	N/A	129°	70 hrs	165	80	0	halyard shackle; AIS failure
<i>Freezing Rain</i>	Hallberg-Rassy 46	Don & Marie Irvin	Astoria, OR	Puerto Vallarta 4/25	Hiva Oa 5/18	22	2,989	126°	59 hrs	168	112	0	watermaker; reefer; generator; etc
<i>Ghost</i>	Hanse 47	Brad & Kat McMaster	Southampton, UK	Galapagos 5/4	Nuku Hiva 5/25	21	3,000	87°	72 hrs	150	115	3	diagonal stay failure
<i>Hokimai</i>	Farr 46	Neil Burson	New Zealand	Cabo San Lucas	N/A	20	N/A	N/A	36 hrs	205	110	5	none
<i>Ile de Grace</i>	F/P cat 44	Jon & Jennifer Glaudemans	Annapolis, MD	Galapagos 3/20	Hiva Oa 4/15	21	3,000	91°	100 hrs	210	60	0	none
<i>Island Mistress</i>	Wellington 47	Jeff & Judy Wahl	Yankton, SD	Puerto Vallarta 12/1	Huatulco 1/1	...	note: boat took on water, thus major vessel mechanics were ruined; returned to PV						
<i>Jarana</i>	J/42	Bill & Kathi Cuffel	Seattle, WA	Puerto Vallarta 4/9	Hiva Oa 4/29	19	2,700	129°	24 hrs	197	98	0	autopilot drowned; spinnny tear
<i>Kamaya</i>	Stevens 50	Rayle-Berkowitz family	Hood River, OR	Galapagos 4/15	Fatu Hiva, 5/2	16	2,900	N/A	9 hrs	204	140	2	gen wtr pump; old batteries failed
<i>Kijiro</i>	Lavranos 31	John & Jean Ranahan	Lorain, OH	Galapagos 5/1	Hiva Oa 5/22	22	3,000	N/A	24 hrs	170	60	5	engine problems
<i>Mary Powell</i>	Discovery 37	Stephen Dolman	Vancouver, BC	LaCruz 3/11	Hiva Oa 3/31	20	2,817	132°	5 hrs	170	93	10	broken shroud wires
<i>Nakia</i>	Hans Christian 33	John Gratton	San Francisco, CA	Hilo, HI 4/3	Nuku Hiva, 4/22	20	2,240	140°	70 hrs	135	60	0	windvane; steering cable
<i>Nikita</i>	Hallberg-Rassy 40	David & Rae Ann Duer	Seattle, WA	Galapagos 4/29	Fatu Hiva 5/16	17	2,900	N/A	12 hrs	178	158	0	bolt broke on furling head
<i>Northfork</i>	Amel 53	Mark Hayden	Incline Village, NV	Panama 7/5	Fatu Hiva 7/21	17	N/A	N/A	25 hrs	N/A	N/A	N/A	blown sails; generator impeller
<i>Oso Blanco</i>	Nordhavn 64	Ann & Eric Bloomquist	Ashland, WI	Puerto Vallarta 4/1	Nuku Hiva 4/17	16	2,714	128°	all	212	180	2	none
<i>Paikaea Mist</i>	Beneteau Custom 50	Michael & Gloria Hanssmann	Vancouver, BC	La Cruz 3/20	Hiva Oa 4/8	18	2,730	128°	44 hrs	210	40	0	baby stay; masthead halyard block
<i>Pincoya</i>	Island Packet 44	Gene Dennis & Gloria Watson	San Carlos, MX	Puerto Vallarta 3/21	Hiva Oa 4/11	22	2,850	130°	112 hrs	180	45	4	boom separated from gooseneck
<i>Proximity</i>	Swan 41	Rod Lambert & Liz Lehmsberg	San Francisco, CA	La Cruz 3/23	Marquesas 4/16	24	N/A	126°	105 hrs	186	82	0	mileage log; wind generator
<i>Puerto Seguro</i>	Morgan 38	Esteban & Maria Font	Florida	Galapagos 4/6	Fatu Hiva 4/30	24	3,200	85°	72 hrs	150	90	6	none
<i>Pylades</i>	Van de Stadt 39	Fergus Quinlan & Kay Cronin	Galway, Ireland	Galapagos	N/A	20	N/A	83°	few	166	121	0	none
<i>Reflections No. 1</i>	Alexander 30	Alex Kao & Leah Prentice	Vancouver, BC	Galapagos 4/20	Fatu Hiva 5/15	24	3,000	88°	144 hrs	151	90	3	autopilot; snapped fishing rod
<i>Renova</i>	Cape Dory 36	John Fremont & Naomi Tabata	Campbell River, BC	Galapagos 4/9	Hiva Oa 5/1	23	3,032	N/A	30 hrs	154	106	3	furling drum; steering bearings
<i>Soggy Paws</i>	CSY 44	Dave & Sherry McCampbell	Marathon, FL	Galapagos 3/10	Gambiers 4/6	27	3,520	N/A	N/A	145	90	0	none
<i>Sula</i>	Brandlemayer 41	Betty & Herb Weston	Tacoma, WA	Puerto Vallarta 4/26	Hiva Oa 5/17	22	3,003	126°	100 hrs	180	47	0	Autopilot; heat exchanger; tranny
<i>Tagish</i>	Brent Swain 36	Brian Vezin	Vancouver	La Cruz Mexico 3/26	Fatu Hiva 4/22	26	2,850	129°	82 hrs	132	70	0	main sheet tear; shroud unraveled
<i>Tahina</i>	St Francis 50 cat	Karen & Frank Taylor	Wilmington, NC	Galapagos 4/24	Hiva Oa 5/1	15	3,103	88°	55 hrs	152	151	2	nothing significant
<i>Tar Baby II</i>	West sail 32	Louie & Alicia van Praag	Australia	Puerto Vallarta 3/14	Hiva Oa 4/12	29	N/A	130°	96 hrs	130	30	2	tiller/pilot failed, improvised repair
<i>Tenaya</i>	Hallberg-Rassy 40	Jim & Katie Thomsen	San Diego	Galapagos	N/A	19	3,965	89°	98 hrs	189	92	3	jib head shackle broke
<i>Terrapin Flyer</i>	Hylas 49	Alex Viterbi	Mammoth Lakes, CA	Cabo San Lucas 4/25	Nuku Hiva 5/14	19	2,900	135°	12 hrs	175	120	5	a few leaks
<i>Totem</i>	Stevens 47	Gifford family	Eagle Harbor, WA	Puerto Vallarta 4/1	Hiva Oa, 4/21	21	2,950	129°	30 hrs	193	103	0	SSB failed; masthead tricolor failed
<i>Trim</i>	Del Rey 50'	Ken & Lori Newell	Long Beach, CA	La Cruz 3/26	Hiva Oa 5/15	22	2,820	130°	68 hrs	178	95	0	gooseneck fitting
<i>Verite</i>	Catana 50 cat	Piersons Overseas Ltd	BVI	Galapagos 3/14	Hiva Oa 3/27	14	N/A	N/A	N/A	270	N/A	N/A	sail halyard eye & stitching
<i>Whoosh</i>	Pearson 42	Jack & Patricia Tyler	St. Pete, FL	Galapagos 4/15	Hiva Oa 5/6	21	3,113	N/A	20 hrs	193	78	0	none

PACIFIC PUDDLE JUMP RECAP

controversial undertaking. During that time the winds were 12 to 21 knots with 6- to 10-foot seas. That really smoothed out our sailing and was very exciting."

The biggest thrill for Brian Traut-

"Three red-footed boobies spent the night on the bow about 350 miles shy of the Galapagos."

man and Erin Russ of the Seattle-based Amel 53 *Delos* was "diving at Isla San Benedicto (350 miles off the Mexican mainland). It added miles to our course, but we got to ride giant manta rays for a week!"

Rod Lambert of the San Francisco-based Swan 41 *Proximity* recalls, "The high was being alone on the ocean with the love of my life. Elisabeth and I were both very happy — the desolation of it was amazing and awe-inspiring."

For Mark Hayden of the Nevada-based Amel 53 *Northfork*, "The high point was when a pod of dolphins swam with us as

we headed into the Galapagos."

Aboard the Ireland-based Van de Stadt 39 *Pylades*, Fergus Quinlan and Kay Cronin recall, "High points were the stars at night without light pollution, and jumping rays."

Jim and Katie Thomsen enjoyed the "beautiful sunrises and sunsets, and the solitude," aboard their San Diego-based Hallberg-Rassy 40 *Tenaya*, plus "visits from bottlenose dolphins, Risso's dolphins, pilot whales and a sperm whale that swam right next to the boat. Also, three red-footed boobies spent the night on the bow about 350 miles shy of the Galapagos."

Aboard *Totem*, the Gifford family loved the "sunsets in the ITCZ, with spectacular clouds and colors, sharing dinner in the cockpit, and the great sailing days, when we thought, 'Now this is what people talk about!'"

The high point for Ed and Cornelia Gould of the Half Moon Bay-based *A Cappella* was clocking a 200-mile day. "Pretty good for a Valiant 42."

For Louis and Alicia on *Tar*

Baby II the best part of the trip was "a couple of really calm days with no wind and no swell. It is amazing how calm the ocean can be way out there," says Alicia. "The rare days when we had about 15 knots of wind and light seas were also cherished!"

Aboard the New York-based Lagoon 41 cat *Dignity*, "The high point was sailing with a pod of 30 to 40 short-finned pilot whales for two hours," recalls Steve Southwood.

"Making landfall at Easter Island after so many years of research, anticipation, and fear" was the high point for Dave and Sherry McCampbell of the Florida-based CSY 44 *Soggy Paws*.

But for Allan and Alison Gabel of the Channel Islands-based Catalina 45 *Fly Aweigh* "The best part was swimming across the equator! The wind was dead and the seas were flat, so three of us jumped overboard and swam across the equator, while the fourth kept the boat beside the swimmers. Then, as they were drying off, we drifted north again, giving our fourth crewmember a chance to swim across as well. That felt fabulous! We offered a few treats to Neptune, of

course: some wine and a popsicle."

Equator-crossing celebrations have always been an uplifting part of this transit — often involving wearing wacky costumes, sharing a toast with King



FLY AWEIGH

After their swim, the entire crew of 'Fly Aweigh' — Allan (behind), Alison, Tiffany and Greg — dressed up to toast King Neptune.

Neptune and forcing new 'shellbacks' to eat or drink some noxious concoction.

Aboard the San Francisco-based Hans Christian 33 *Nakia*, John Gratton recalls, "We drank some rum and poured a hefty amount over the side for Neptune. This was our fifth equator crossing, and it seems like every time we send more and more booze to the King while asking for good weather."

In the same vein, John Ranahan of the Ohio-based Lavranos 31 *Kijiro* set an unusually high bar by sharing some of his precious 1919 Angostura Trinidadian rum with the lord of the oceans.

Jack and Patricia Tyler's equator-crossing anecdote about what took place aboard their St. Petersburg, FL-based Pearson 42 *Whoosh* made us cringe: "We suited up in appropriate King Neptune and Fair Maiden costumes, positioned our camera and snapped a photo. But just then an unexpected swell tossed the boat, and the \$1,000 camera took a header from the companionway to the cabin sole." The photo reportedly turned out great, but the camera was toast.

For many sailors, one of the most impressive parts of a long crossing is making landfall. Some are overcome by



AQUILA

FAST, ROWDY & FUN —

emotion, while others simply feel a great sense of relief.

Ken and Susan FitzGerald of the Seattle-based Caliber 40 *Bint al Khamseen* report: "We were ecstatic. Couldn't get enough of the scents of the island."

Behan of *Totem* agreed: "The smells were overwhelming — earthy, spicy, floral. . . It's amazing how your senses are sharpened by time spent on the big blue."

Ed and Cornelia of *A Cappella* note: "We were excited, but could hardly walk after almost three weeks at sea."

Brian of *Delos* says: "I felt exhilaration, excitement, and the most incredible craving for a cheeseburger and a beer."

"We were very tired, as we came in at midnight when it was pitch black," recall Dr. Simon and Jane Elix of the Australia-based Fountaine-Pajot 42 cat *Elixir*. "The next morning we awoke to the most surreal sight: the volcanic peaks of Nuku Hiva looming above us!"

No matter where you set out from, completing the Puddle Jump is no small



TENAYA

Jim Thomsen of San Diego-based Hallberg-Rassy 40 'Tenaya' strikes a pose with his catch of the day — a nice Mahi.

feat, and the lessons learned along the way are well worth heeding. Fleet members offered the following advice to future Puddle Jumpers:

"The destination is well worth the effort! Get a long-stay visa before you leave your home country. Three months here

is definitely not long enough!" say John Fremont and Naomi Tabata of the British Columbia-based Cape Dory 36 *Renova*.

Vince of *Fidelis*: "Stay out of the mid-Pacific ITCZ. I crossed near the Galapagos with its attendant wind patterns, went to 5°S and made the bulk of my transit there. I had good winds while listening to the lamentations of others."

Ann and Eric Bloomquist of the Wisconsin-based Nordhavn 64 *Oso Blanco*: "French Polynesia is a mysterious, wonderful place with lots of adventure and things to learn."

Gene of *Pincoya*: "Bring dive gear. We would have lost our anchor gear in coral without the ability to go down and unravel it from the coral canyons. Also, get those new sails ahead of time instead of trying to make your old ones last. Bring beer and booze. We're still drinking Mexican beer here in the Societies where it costs more than \$2 per can, and vodka or rum is \$35 for a fifth."

David and Rae Ann of *Nakia*: "Relax and keep it reefed. Going slow is not a

Your Boatyard in the Heart of Paradise



Large, fenced, secure dry storage area

Tahiti Customs policy has changed!
Foreign Flag vessels can stay on dry storage in our yard for up to 12 months out of 24.



A Subsidiary of
The Moorings Yacht Charter, Ltd.

Our Services |

HAULOUT

- Marine Travelift 25 tons
- Marine railway 120 tons
- Storage in adjustable steel cradles
- Fenced Yard

PAINTING

- Topsides, hull, bottom, varnish
- Brush, roller, spray

MECHANICAL WORK

- Inboard, outboard, diesel, gas
- All brands

REPAIRS

- Electrical repairs
- Refrigeration installation & repair
- Fiberglass & woodwork
- Welding, steel, stainless, aluminum

SAIL LOFT

- Sail repairs, biminis, dodgers, covers

STORE

- International, Pettit, Epiglass, Devoe
- Spares
- Fill U.S. gas cylinders

DO-IT-YOURSELFERS WELCOME!

BoatUS Cooperating Marina



Professional boatyard in the heart of Paradise

Raiatea Carenage will make sure
paradise is everything you expected.
Call, write, or sail in . . . we're here to serve you.

B.P. 1111 Uturoa Raiatea 98 735 Polynésie Française

Tel: (689) 600-545 ~ Fax: (689) 600-546 ~ VHF 68

Web site: <http://www.raiatea.com/carenage> ~ email: raiateacarenage@mail.pf

PACIFIC PUDDLE JUMP RECAP

sin."

Don of *Freezing Rain*: "Make sure you have several methods of getting weather info and make sure your SSB email setup for SailMail or Winlink works before you depart. As long as you have good communications, you will have support for trouble-shooting breakdowns. Take lots of spare parts."

Brian of *Delos*: "There are really big

*"Just do it.
Leaving the mainland
is the hardest part."*

fish out there. Buy twice as many lures as you think you'll need, because you'll lose lots of them until you get it down. They don't need to be huge. We got large fish on small to medium lures. But only use steel leader and a minimum of 90-lb test for reels (400m) and 300-lb for

handlines. If you use a reel, buy a good quality one, not a cheapo brand. It will more than pay for itself. And bring a hatchet for splitting open coconuts!"

Jim and Katie of *Tenaya*: "Be prepared for the places you'll be visiting. Have guidebooks for land as well for as anchorages in order to get the most out of your visit. Attempting to speak the language, no matter how badly, is always well received. Smile, be humble and thankful."

Tim Rayle and Ruth Berkowitz of the Oregon-based *Stevens 50 Kamaya*: "Go to the Galapagos first and get an *autografo* (cruising permit) so you can stay a long time and really get a feel for the animals."

Alex Kao and Leah Prentice of the Vancouver, BC-based *Alexander 30 Reflections No. 1*: "Just do it. Leaving the mainland is the hardest part. Everyone stalls as much as they can, but once



PUPPY

If we had to guess, we'd say this shot of Natasha and Anatoli of the LA-based Westsail 32 'Puppy' was taken in Tahaa's Coral Gardens.

you're off, it's good."

Brad and Kat McMaster of the UK-based *Hanse 47 Ghost*: "Keep the key boat systems simple, redundant and non-integrated, and don't set unrealistic expectations. It isn't about the miles per day, it's about arriving at the other end while caring thoughtfully for your crew and their experiences."

Rod of *Proximity*: "Don't fall into 'chasing your tail' during preparation. We

The Simple Choice For Fresh Water

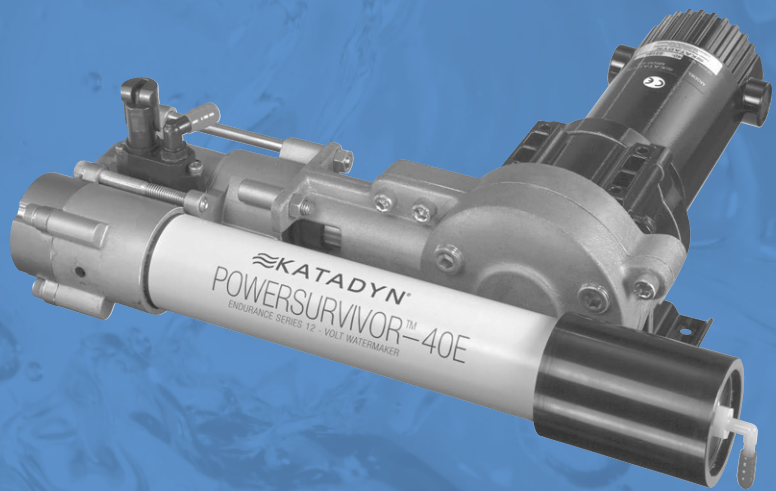

Katadyn PowerSurvivor Watermakers are small, reliable and easy to maintain. That's why they are the best selling watermakers for cruising sailors.

Making your own fresh drinking water is a great addition for the independent lifestyle. Katadyn watermakers are simple in design, moderately priced and have proven reliability.

For about \$3,400, it's a great way to improve life onboard.

800.755.6701 • www.katadyn.com

KATADYN
MAKING WATER DRINKING WATER

FAST, ROWDY & FUN —

watched many people work themselves into a near-panic trying to gather and assimilate each and every document on the Puddle Jump website, as well as attend each and every seminar. Just prepare well, then give yourself some time to relax. Also, don't be afraid to get away from the herd. Although our fellow cruisers are wonderful people, and we love 'em, there are many wonderful local people along the way you'll want to meet too."

Steve of *Dignity*: "If sailing from the Galapagos, make 2°S as soon as possible but don't cross 4°S until you reach 130°W. This keeps you in the favorable current for much longer and gives a much better sail to Fatu Hiva — which is a much more stunning landfall than Hiva Oa."

Simon of *Elixir*: "If starting from Mexico, cross the equator early and get into the southern trades and current. Once you start hooking the big fish, we found it best to heave to! Stick to the pelagic fish, as ciguatera (found in some reef fish) is *nasty*."

Doug of *Fellow Traveler*: "Don't follow



PAIKEA MIST

About 300 miles off Mexico, Michael couldn't resist checking the view from the top of 'Paikaea Mist's mast as the breeze began to fill in.

the crowd. Go to the Gambiers."

Joel Ungar of the Santa Barbara-based Island Packet 350 *Alobar*: "Listen and learn as much as you can. Keep lots of spares, and from time to time check the screws that hold the roller-furling foils together."

Jon and Jennifer Glaudemans of the Annapolis, MD-based Fountaine-Pajot 44 cat *Ile de Grace*: "Relax, watch for chafe, and bring a lot of books."

Dave and Sherry of *Soggy Paws*: "For those doing the same route we did — via the Galapagos, Easter Island and Pitcairn — leave a little earlier in the year, and build in some time for 'delay points'. Get the Galapagos *autografo* (cruising permit) and allow enough time in the Galapagos to enjoy it. Getting there early means you can enjoy the anchorages without having to share them with 200 other cruisers."

Michael Rafferty of the San Diego-based Islander Freeport 36 *Aquila*: "Have a watermaker, plenty of cedar plugs for fishing, and bring lots of paper towels!"

Herb and Betty Watson of the Tacoma, WA-based Brandlemayer 41 *Sula*: "If you take crew, check them out by sailing around before you make the passage. Ideally, do several overnights."

Kathi of *Jarana*: "The best advice I was given was to get audio books for my

Let Hydrovane sail you home safely.



▲ Polar circumnavigator Adrian Flanagan.



Latest ARC survey — Hydrovane again the most popular wind vane.

Totally independent self-steering system and emergency rudder... in place and ready to go.



SURVIVE YOUR DREAM

info@hydrovane.com PHONE 1.604.925.2660

REPAIR REPAIR REPAIR

NOW AT GRAND MARINA

ROOSTER SAILS
A REPAIR LOFT

YOUR ROLLER FURLER UV COVER SPECIALIST

ROOSTER SAILS

2021 Alaska Packer Place, Box 18, Alameda
(510) 523-1977

www.roostersails.com • rui@roostersails.com

Open M-Th 9-6 • Fri 9-5 • Sat by appt.

Owned and Operated by Rui Luis • Experienced Sail Repair and Fabrication

NOW OFFERING NEW CRUISING SAILS!

SAIL REPAIR SPECIALISTS • COMPETITIVE RATES • RECUTS • CONVERSIONS

PACIFIC PUDDLE JUMP RECAP

MP3 player. It saved my sanity. Also good crew really helps in every way. Ours was a total hero."

Michael and Gloria Hanssmann of the Vancouver, BC-based Beneteau 50 *Pai-kea Mist*: "Be open-minded and flexible in your approach; be willing to change routes, watches, and, of course, sails in order to make the most of your crossing. Prepare yourselves and your boats well,

"Above all else, trust your boat. She truly is at home in the blue water!"

and above all else, trust your boat. She truly is at home in the blue water!"

This year's Pacific Puddle Jump is one that won't soon be forgotten, as it featured a record number of entries,

several dramatic rescues, and conditions so challenging that a group of first mates has banded together — seriously — to form the Flying Wives Club, in anticipation of their boats' future ocean crossings.

For many sailors, doing the Jump is not only a *passage*, but a *rite of passage* — or an entry on their 'bucket list' — that they anticipate for years, if not decades. As we write this, in fact, a new batch of dreamers is already solidifying their plans for the 2011 crossing.

If you'd like to learn more about the voyage and our associated Tahiti events, consider attending one of our free Puddle Jump seminars: October 23 in San Diego at West Marine (5 p.m.; 1250 Rosecrans); in late January (date TBA) at the Seattle Boat Show; or in mid-April at the Strictly Sail Pacific show (date TBA).



MARIA FONT

Catching and boating this shark in mid-ocean brought out the animal in Estaban Font of the Argentina-based Morgan 38 'Puerto Seguro'.

And if you're ready to register, our new online sign-up process should be up and running by the end of this month at www.pacificpuddlejumps.com.

There's no doubt about it. The Pacific is one big patch of water. Perhaps that's why so many sailors seem to hear its call so clearly.

— **latitude/andy**

Welcome Baja Ha-Ha Cruisers...

To the three best Marinas in Southern California!

Whether you're heading north or south or simply want to find somewhere to stay for a while, our marinas...

Ventura West Marina, Dana West Marina and Harbor Island West Marina are the places to stay for convenience, comfort and friendliness.



Ventura West Marina
805.644.8266
1198 Navigator Drive
Ventura CA 92001
www.venturawestmarina.com

Dana West Marina
949.493.6222
24500 Dana Pt Harbor Dr
Dana Point CA 92629
www.danawestmarina.com

Harbor Island West Marina
619.291.6440
2040 Harbor Island Drive
San Diego CA 92101
www.harborislandwest.com

'ROUND THE WORLD

The big trend in long distance cruising during the last 10 years has been the dramatic increase in the number of multihulls, almost all of which are catamarans. Ironically, though, in the early days of cruising multihulls, trimarans rather than catamarans were the most popular. Since we don't hear much about cruising trimarans these days, it was nice to hear from Anne and Don Taber of Santa Cruz, who completed a five-year circumnavigation on Father's Day of last year aboard their Marples 44 Redwood Coast II. Don built the trimaran himself over a five-year period, 25 years ago. Below, Anne shares some tales from their lap around the planet, as well as a few thoughts on monohulls versus multihulls for cruising.

Don has been a multihull sailor since the '70s, and nothing would persuade him to turn to a monohull. But



Don and Anne Taber kicking back in Malaysia during a five-year circumnavigation aboard their Marples 44 trimaran 'Redwood Coast II'.

he stopped proselytizing years ago. I'm a former monohull sailor, but I can't imagine ever going back to the chaos of cooking on a monohull in a following sea, or having to sleep wedged into a bunk. It's hard to beat the comfort of sleeping on an almost-always level boat, but the downside is that the mooring fees can be shockingly expensive. For instance, we were charged \$9/ft./night at Finike, Turkey, because *Redwood Coast's* footprint is 120 sq. meters. And the Finike Marina was one of the less expensive ones.

The good side of having a boat that covers a large area is that there's lots of room to move around, and there's plenty of deck space for solar panels. *Redwood Coast*, for example, had six 70-watt solar panels on the amas. As a result, during our five-year cruise we never once plugged into shore power. Furthermore, we never had to run the engine in order to keep our house batteries charged or keep the refrigerator cold. During our Zihuatanejo-to-Zihuatanejo circumnavigation we ran our engine a total of just 1,800 hours in four years.

Monohullers frequently inquire about

our trimaran's top speeds. While *Redwood Coast* can hit double digits fairly easily, it's hard to maintain such speeds over several days or even 24 hours. In fact, we found our trimaran's most surprising performance to be in super light winds.

Don and I had cruised extensively on *Redwood Coast* prior to our circumnavigation, and we couldn't help but notice how many more large cruising catamarans are out there these days. What are the pros and cons of each? We don't really have an opinion because we haven't had any experience on large cats.

The following are some of the highlights from our circumnavigation.

We left Santa Cruz in the winter of '04 and made it down to Zihua in time for SailFest in January of '05. That year Z-town turned out to be the best place, weatherwise, from which to head across to the Marquesas. Our passage was 18 days. An injection pump repair in Mexico turned out to be the precursor to our engine 'blowing up' in Taiohae. After a couple of days of troubleshooting, Don determined that the valve was stuck in the piston. The engine manufacturer assured us that they would send a replacement long block to Tahiti as soon as possible. Being engineless, it would have been foolish for us to try to sail in and out of the tricky lagoon entrances of the Tuamotus, so we had to forget those. In fact, the only way we could enter the reef at Tahiti was by tying our dinghy between our main hull and starboard ama and powering into the anchorage at Marina Taina at four knots.

"ASAP" for the engine manufacturer meant it arrived by air five weeks later. We'd spent the waiting period clearing out the engine room, and stripping the motor of parts we would reuse. Twenty-four hours after taking delivery of the long block, Don had the engine up and running!

After adventures in French Polynesia,

we made the jaunt up to Penrhyn in the Northern Cooks, then continued along the northern route via Suvarrow, American Samoa, Samoa, and Tonga. Once New Zealand weather guru Bob McDavitt gave us the green light for the passage

"As a result, during our five-year cruise, we never once plugged into shore power."

from Tonga to New Zealand, we were off. We made the 1,100-mile trip in 5.5 days, at an average of 8.3 knots.

After a season in Opua in the Bay of Islands, we sailed back to Fiji. Our first destination was Kandavu, which is often overlooked by yachties because it's an all-day uphill sail from Suva. We found a fantastic anchorage in Daku Bay, not far from an island resort. Since the island is remote and technical support is nonexistent, Don, who's an electrician by trade, was asked to look at the installation of a solar array. The resort owner, tired of having to run a generator 24/7, seized the opportunity to hire Don to get things



ALL PHOTOS COURTESY REDWOOD COAST II

— ON THREE HULLS

straight over a period of several weeks. Friends Chris and Nancy Zingler on the Brewer 44 *Amulet* dropped anchor and volunteered to help on the project.

During the couple of weeks it took the guys to get everything sorted out, the owner asked if we were interested in managing the resort for three months until the new managers arrived. It didn't take much convincing, so after a month of cruising in the area we took over as temporary managers of the 30-bed beach resort. This happenstance job would turn out to be the highlight of our years of traveling. As Kandavu is home almost exclusively to Fijians, as opposed to Fijians of Indian descent, we really got to experience the culture and made great friends. It was a very sad day when our time was up. Having spent the entire cruising season in Fiji, we decided to return to New Zealand for the summer cyclone season.

By then we'd made plans to do a circumnavigation. We briefly revisited Fiji, stopped by Vanuatu, then set sail for Darwin in time to join the Indonesia Rally that helps with cruising permits

'Redwood Coast II' tucked into an anchorage in Turkey, where Anne supplemented their kitty by opening the first foreign West Marine store.

and other paperwork. Indonesia is a vast and intriguing country, and was quite the experience during Ramadan. We avoided the crush of yachts in the rally, and slowly moved on to Malaysia and Thailand. We'd originally entertained the idea of spending a second season in Southeast Asia, but the heat and humidity proved to be too much for us.

Our crossing of the Indian Ocean, with a pit stop at Uligan in the Maldives, was uneventful. Surprisingly, we really enjoyed our stops at both Oman and Yemen, as the people were extremely friendly and curious. Not once did we feel uneasy being Americans in the Arab world. The dreaded trip up the Red Sea wasn't as bad as we had anticipated. In fact, we think the Baja Bash is much worse. After all, there is

an untold number of anchorages on the west coast of the Red Sea, and therefore no need to crash north when the wind is blowing hard. By the time we got free of Port Said along Egypt's Mediterranean coast, we were glad to turn our backs



The tri's footprint means moorage can be expensive; with the room for six 70W solar panels, the Tabers never had to plug into shorepower.

on Egypt. The constant demand for *bak-sheesh* had been overwhelming.

Once we'd made landfall in Turkey, we heard that West Marine was opening its first overseas franchise — in Istanbul! As a former manager of the Santa Cruz store, I had participated in a number of store openings and was eager to assist the new owners in their endeavor. A kind and encouraging word from West Marine founder Randy Repass convinced West-Marine/Turkey to hire me. Thus began another extremely satisfying foreign work experience. For six weeks I worked with the local store staff to turn a huge empty box into a brand spankin' new West Marine! It so happened that the company owns most of the marinas in Turkey, and therefore we were able to get an extra-wide Med-moor slip in the Kalamis Marina in Istanbul — something normally very hard to come by.

By the time we left Turkey in July, it was high time for us to get going west. After all, we wanted to get to Gibraltar no later than the beginning of October. So we breezed through Greece, Sicily, Sardinia, the Balearic Islands and mainland Spain. We arrived in Gibraltar just in time to miss the first storm of the season, which was so wicked that it destroyed much of the already fragile breakwater and put a freighter on the rocks.

Our Atlantic crossing featured mostly light winds, and was one of our slowest passages. We made the crossing with *Moorea* and *Ohana Kai*, two Seattle boats



'ROUND THE WORLD

that were also on the homestretch of circumnavigations. We arrived in Martinique on Christmas Eve of '08. In short order, we headed south along the Windward Islands and on to the ABC's, Cartagena and the San Blas Islands. We transited the Panama Canal without any problems.

Once we got back into the Pacific, we pretty much hurried through Costa Rica and Mexico, with only occasional stops. Our trip up the Baja coast featured the usual misery. We had 30 knots of wind off Big Sur and gale-force winds in Monterey Bay. In other words, our welcome home was a whipping from the weather. We returned to our home port of Santa Cruz on Father's Day '09.

Reading in the June issue about the group passage through Pirate Alley brought back memories of our trip through that area in the spring of '08. Having arrived with the first group of yachts in Salalah, Oman, from the Maldives, we hooked up with the Norwegian



'Redwood Coast II' is capable of double-digit speeds in the right conditions, but it's her light air performance that really makes her shine.

yachts *Stormsvalen* and *Uterus* — no, that's not a typo! — for the 600-mile trip to Aden, Yemen. We took the usual precautions like running without navigation lights at night and staying in close proximity of each other. Don came up with the brilliant idea of selecting a Canadian/US Coast Guard VHF channel

for communication between us as all three boats had Icom VHF's.

A British navy ship was in Salalah for repairs and yachts were encouraged to "register" their particulars with them. The area off the coast of Somalia, south of the Horn of Africa, is especially prone to attacks on merchant ships. The northern Somalian coast, opposite of Yemen, is frequented by boats smuggling human cargo from Somalia to Yemen. The traffickers are the ones that have been responsible for attacks on yachts in previous years.

Luckily for us the European coalition forces patrol these waters and are keeping an eye on things. The first night, around 10 p.m., we had our first encounter with the watchdogs. A helicopter circled our little convoy a couple of times with infrared lights, then took off. A short while later we saw a ship's silhouette in the moonlight, slowly approaching us without any kind of light. The ship

DON'T
LABOR
ONE MORE
DAY
ON TIME-CONSUMING
BOAT PROJECTS!

SAN FRANCISCO BOAT WORKS

835 Terry A. François St., San Francisco, CA 94158
(415) 626-3275 Fax (415) 626-9172

CALL US - SEVEN DAYS A WEEK!

Be our guest for lunch at the historic Ramp Restaurant*

*Some restrictions apply



**We'll save you time
and money with
summer discounts
and specials!***

**REQUEST A HAUL-OUT ONLINE!
ORDER PARTS ONLINE!
www.sfboatworks.com**



— ON THREE HULLS

shadowed us for some time and failed to respond to calls on the VHF. We were reasonably sure it was a war ship and it was confirmed when they reappeared the next morning.

The skipper of the German warship contacted Tom on *Stormsvalen* and apologized for not answering us the previous night. He went on to explain that they were conducting a covert operation and had to maintain radio silence. He knew all about our group, as the info we submitted to the British was passed along to all coalition ships patrolling the area. In hindsight we probably would have done approaching freighters a big favor by displaying our running lights at night to let them know we were friendly sailboats and not a pack of outlaws waiting to pounce on them.

All of us were a bit on edge given the reputation of the area. One night while on watch, captain Don decided to pass the time by fixing the battery monitor that had started giving off weird readings. With *Stormsvalen*, *Uterus* and *Red-*

wood Coast II traveling in a diamond formation, with a mile or so in between us, Don started trouble-shooting. As we spent most of the trip motor-ing in very light air, we kept both the radar going and the VHF on our "private" channel.

Unbeknownst to him, Don accidentally turned on the running lights. Some time later he heard Tom and Benjamin engaged in excited conversation in their native tongue. Thinking nothing of it, Don continued undeterred. What finally got his attention was when both *Stormsvalen* and *Uterus* were closing in on us. Before long both boats came



The tri's shallow draft means that commonly-found ordinary ways are sufficient for hauling out — a boon in less developed areas.

close enough to yell across. Having failed to answer them on the VHF earlier, the Norwegians were convinced that we'd been boarded by pirates and had turned on our lights to show we were in distress. Nothing like a little excitement when emotions are already running high!

— anne taber



FREE CRANE FREE LAYDAYS

You will never see a crane charge or layday charge when we pull your rig at our dockside location.

Why pay more for less?

Best Service • Best Value • Best Results!

Call now for a quote...



Easom Racing and Rigging

1230 Brickyard Cove Rd., Suite 102
Point Richmond, CA 94801

(510) 232-SAIL (7245)

www.easomrigging.com

BAJA HA-HA PROFILES, PT I

Remember Bill Murray's classic 1993 film *Ground Hog Day*? We're reminded of it each fall when the Ha-Ha rolls around again: "Really? It's that time again?" But don't get us wrong, we love doing this San Diego to Cabo San Lucas rally year after year even more than we love Murray's hilarious flick.

And it's not that we have to keep doing the rally over again until we get it right. Whether by sheer genius or dumb luck, we seem to have found the perfect formula for a fun-filled cruising rally right from the start: pick a route that lends itself to multiple stopovers in gorgeous, well-protected anchorages; set up guidelines for safety, but keep the rules to a minimum; and encourage sailors of all stripes to join in the PG-rated fun.

With stops en route to Cabo at Bahia Tortugas and Bahia Santa Maria, the Ha-Ha game plan is one that's required very little tweaking since the event's inception in '94 — a fact that's born out by the number of repeat customers who sign up every year. Here then, are members of the Baja Ha-Ha 'Class of 2010' — listed in the order they signed up. (*The first of three monthly installments.*)

Thee Amazing Grace — Vector 39
David Bloom & Karin McGinley
Long Beach

Noteworthy: *Thee Amazing Grace* was built in Seattle in 1979, in dry storage until commissioning in '86; in dry dock until '94; but never sailed until David and Karin bought her in '96.

Piko — Wauquiez Pretorien 35
Lauren Buchholz & Lauren Smith
Seattle, WA

Noteworthy or Quote: Owner Lauren Buchholz has done every project on the boat herself, including a full repower.



Robert will hang a left aboard 'Day Dream'.

Day Dream — J/122
Robert Day, San Francisco

Quote: So, you go under the Golden Gate Bridge and turn left, right?

Cat's Meow — Catalina 36
Nancy & Mike DeMauro, Richmond

Noteworthy: Nancy's crew for the run to the Cape will be her older brother Mike.

Noho 'ana — Jeanneau 37
Heather McKnight & Peter Lewis
Marina del Rey

Noteworthy: When they were moored at Catalina on their previous boat, a Catalina 30, Heather said, "I could live on a boat — just not this one." They've been living aboard *Noho 'ana* for the past eight years "and love it."

Last Resort — Catalina 470
Dick & Sharon Drechsler
Marina del Rey

Noteworthy: Set up for comfortable liveaboard cruising, this boat has a washer-dryer and a 45" plasma TV.

Di's Dream — Catalina 470
Roger & Diana Frizzelle
San Francisco

Quote: The two-time Ha-Ha vets say, "We're doing it again in 2010! This time we plan to stay gone!"



Meet the 'WindChime' crew.

WindChime — Hunter 430
Neal Albrektsen, San Diego

Quote: After many years of watching the fleet sail out from San Diego Bay, it is finally my turn to sail with the Ha-Ha fleet.

Dolfin — Crealock 37
Bill Meanley, San Diego

Noteworthy: Bill, Patty and their daughter Kelly did a 20,000-mile family cruise aboard this same boat throughout the South Pacific and back by way of Canada from '87 through '89.

El Tiburon — Tayana 47
Sarah Powell & Darrell Erickson
San Francisco



Quote: "I am just about to jump out of my skin! We have been planning this escape for 14 years!"



The 'El Tiburon' crew is rarin' to go.

Braveheart — MacGregor 65
Bob Callaway, Pleasant Harbor, WA

Quote: "I intend to have an all-female crew for the fun of it!"

Andiamo III — Hans Christian 43
The Reynolds family
Olympia, WA

Quote: "Our family has been serving the US Army for 11 years. We have spend most of those years away from one another because of deployment in support of OEF or OIF or Homeland Security. We have made the decision to separate from

— SAILING TO SUNNIER LATITUDES



A previous Ha-Ha fleet sets sail from Bahia Tortugas at the start of Leg Two. By this point the fleece and foulies have been stowed away.

the military in order to sail our dream while our kids are young. The Baja Ha-Ha is how we decided to get ourselves going."

Arione — Mason 44
Art Stiers & Jaye Eldridge
Anacortes, WA

Noteworthy: Captain Art and crewman Max Stiers will both celebrate Halloween birthdays during Leg Two of the Ha-Ha.



Art and Jaye of 'Arione' are all smiles.-

Norwegian Steam — Jason 35
Alan Westhagen, Seattle, WA
Noteworthy: Alan has owned this Ted Brewer-designed cutter for 34 years.

Robon III — Columbia 50
Dale Walter, San Francisco
Quote: "The things you regret most in life are the risks you did not take."

Cygnus — Sabre 402
Gerald Kitchen, Sausalito
Noteworthy: "The most interesting thing about my entry is that I am able to share a long ocean cruise with dear and experienced friends. The most senior among them, Bruce Munro, owns an identical boat."

Independence — J/32
Joel & Danielle Wells, San Francisco
Quote: "The boat, just like its owners, is at its best in the warm sun and blue waves."

Loose Pointer — Kelly-Peterson 44
Dan Best & Kathryn Sieck
San Francisco
Noteworthy: From '04 to '06 Dan and Kathryn did a Pacific circuit that included Galapagos to Polynesia, Tonga to Hawaii, and Hawaii to San Francisco.

Finarrow — Swan 38
Jim & Cathy Revard, Sitka, AK
Quote: "We'll point her south this summer. But you know how it goes: Man plans and the gods laugh."

Sweet Cherri — Columbia 36
Joshua & Julia Siudyla, Alameda
Noteworthy: The couple has only owned this boat for a year, but they hope doing the Ha-Ha "will be the beginning of a lifetime of cruising."

Althea — O'Day 28
Shawn Passeri & Cindy Spangler
Antioch
Noteworthy or Quote: "We have the equipment of a 45' sailboat compacted into a 28' footer."

Blade — Valiant Esprit Nordic 37
Ed & Karen Lare, San Diego
Quote: "It's about time," say Ed and Karen, who've owned this boat for 26 years.

MissTeak — Morgan 45
Chip & Katie Prather, Dana Point
Quote: "We're wild and crazy cruising people who love to line dance!"



The 'Miss Teak' crew: "All together now..."

Venti — Fontaine Pajot Mahe 36
Lori & Ken Styles, Berkeley
Quote: "We just wanna have fun."

Pua'ena — Outbound 44
Mark & Dorothy Hazlett
Waikiki YC, HI
Noteworthy: Talk about dedication, having sailed from Hawaii to participate in this year's rally, the Hazletts will have traveled more than three times the rally distance to get to the starting line!

Hotel California — Hunter 376
Rick Rheingans & Pam Coite
Alameda
Quote: "We've been hearing about the rally every year from friends who have done it and are still out there. We can't wait to join them."

LATITUDE / ANDY

BAJA HA-HA PROFILES, PT I



Barritt and Renee of 'Serendipity'.

**Serendipity — Kelly-Peterson 44
Barritt Neal & Renee Blaul
San Diego**

Quote: "Serendipity was the last Peterson 44s built," explains Barritt, "and she has always taken great care of us throughout the years."

Liberty — C&C 37

Russell Cooper, San Francisco

Noteworthy: Russell tells us that one of the most interesting things about his boat is that there's a pirate rubber chicken aboard. "It's a long story," he says, and we want to hear it.

**Dancer — Hylas 44
Charles & Patricia Skerry
Marina del Rey**

Quote: "We are working on it."

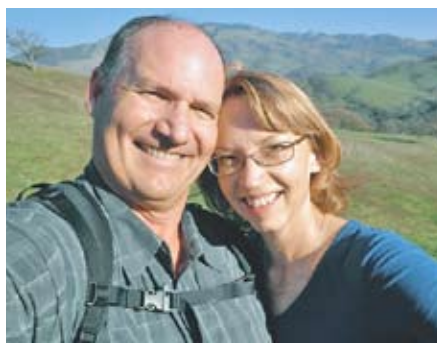

The 'Charisma' crew is testing the waters.

**Charisma — Tayana 37
Bob Johnson, Berkeley**

Quote: Why did Bob sign up? "I'm tired of reading about the Ha-Ha and wishing I was there!" he says. "This year is the 'test year'. Next year we'll come back and do the Puddle Jump."

**Another Girl — Santa Cruz 50
Jim Bewley, Richmond**

Noteworthy: Over the years, Jim has logged thousands of sea miles, including Honolulu to Berkeley in '60s, LA to Mazatlan in the early '70s and two previous Ha-Has.

**Tribute — Beneteau 473
Bruce Crockard & Ed York
Long Beach**

Noteworthy: Each summer since *Tribute* was launched, boat partners Bruce and Ed have taken her to the Channel Islands for at least three weeks.

**Mind Magic — Newport 41 MkII
Dennis & Pamela Young
Long Beach**

Quote: What's their attitude toward breaking away on the Ha-Ha? "It's been a long time coming!" They've owned *Mind Magic* for 17 years.

**Camelot — Catalina 470
Thomas & Lori Jeremiason
Alameda**



RICHARDSON BAY MARINA

formerly Kappas Marina

MODERN FACILITIES IN A WELL-PROTECTED HARBOR

Concrete
Dock System

Well Maintained
Facilities

Beautiful
Surroundings

- DEEP WATER BERTHS: BASIN AND CHANNEL DREDGED
- CARD KEY SECURITY SYSTEM
- DOCK CARTS
- PUMP OUT STATION
- AMPLE PARKING
- CLEAN SHOWER AND TOILET FACILITIES
- IN WALKING DISTANCE: MARKET/DELI, LAUNDROMAT, RESTAURANT
- AT EACH BERTH: LARGE STORAGE BOX, METERED ELECTRICITY, WATER, PHONE HOOKUPS

BERTH YOUR BOAT IN SAUSALITO

415 • 332 • 5510 www.richardsonbaymarina.com

100 Gate Six Road, Sausalito • Fax (415) 332-5812

— SAILING TO SUNNIER LATITUDES



Tom and Lori of 'Camelot' are going aound.

Noteworthy: "This will be the first leg in a planned circumnavigation, which will end with us taking up residence somewhere besides California."

**Salt Shaker — Cape Dory Cutter 36
Richard & Mardi Brayton
Sausalito**

Quote: "As the old saying goes, 'Those that talk don't know; those that know don't talk,'" says Richard. "I'm hoping to come home from this not talking too much."

**Fullshell — Catalina/Morgan 440
Eric & Marilyn Anderson
San Francisco**

Quote: "I've done the Ha-Ha rally twice," says Eric, "and there is no better way to start the cruising life — either as a laid-back transit or a competitive race."

**Balquhider — Hunter Passage 450
Don & Stella Patterson, Tacoma, WA**

Quote: "Been there, done that, got the T-shirt, and I want to do it again," says Don, a veteran of the 2000 Ha-Ha. And this time he's wisely bringing along Stella too.

**Hotel California — Catalina 375
Michael & Linda Stafford
San Francisco**

Noteworthy: "We toured *Hotel California* at Strictly Sail Pacific in '08 as a new Catalina model, then bought her used at the same boat show the following year."

**Voyager — Cooper 42
Jack & Canole Nieman, Homer, AK**

Noteworthy: After the rally, the Niemans will sail on to Hawaii.

Toucan — Tanton 43 cat

Kevin Belcastro, San Francisco

Noteworthy: *Toucan* did the Ha-Ha in both '98 and '99 with previous owners. "This boat is designed to be simple and nearly sail herself," says Kevin. "We're putting that design to the test."

Sans Souci — Gulf 32

**Gary Kunz & Julie Demaree
Portland, OR**

Quote: "May the sun be blazing, the wind be brisk, and my stomach be calm," says Gary.

Is the youngest Ha-Ha'er aboard 'Feliz'?



Anna Stockel heads to Hawaii in the 2000 Singlehanded TransPac.

Use the Autopilot Favored by Singlehanded Racers

**Because for More than 30 Years ALPHA PILOTS
Have Delivered the Highest Performance,
Reliability and Low Power Consumption
These Competitors Demand!**

Why buy an Alpha Autopilot? We'll make your boating more fun!

Singlehanded skippers have proven that the world's best autopilot can steer almost as well as they can, save battery power, be more reliable than most crew members, and almost never break down. But, what really counts is how much more enjoyable your boating can be with an Alpha Pilot!

Please visit our web site at www.alphamarinesystems.com or call **1-800-257-4225** and let our knowledgeable staff discuss how we can put pleasure in pleasure boating.



A World Class Product Built in the USA

Alpha Marine Systems, Inc. 6809 96th Avenue SE, Mercer Island, WA 98040

(800) 257-4225 (206) 275-1200 email sales@alphamarinesystems.com Web site www.alphamarinesystems.com

BAJA HA-HA PROFILES, PT I

Feliz — O'Day 37

The Grumper-Malm Family Berkeley

Quote: "When I asked my three-year-old daughter if I should fill out this event registration, she asked me if they had any toys in Mexico," says Hanna. "I told her yes, put her to bed, and filled out the form."

Valparaiso — Irwin 52

Joe & Susan Arnold, Portland, OR

Quote: "I would like to say, 'Same old ship, different day,'" Joe says, "however 'It's about time' is more appropriate."

Rambler — Ericson 32

Tom Bradley & Linda Hackett Corona del Mar

Noteworthy: Tom says he's built, rigged, raced and delivered boats for other people for 30 years. "This one is for me," he said, "and now I get to do things the right way for me."

Procyon — Gozzard 44 MkII

Randy & Sheri Schneider Sunriver, OR

Noteworthy: Randy and Sheri have

cruised from the East Coast to Australia over the past eight years. "Now we're ready to cruise our favorite part of the world — the Mexican Riviera."



The 'Procyon' crew has cruised the Pacific.

Sundancer — Bluewater Vagabond 47

Heather Reimer Vancouver, BC

Noteworthy: Sundancer is a new boat to Heather, who plans to circumnavigate. "I'm doing the Ha-Ha to shake out the sails on a new purchase," she said.

Rose of Erin — Hughes 40

Damon & Erin Cruz, Juneau, AK

Quote: "If you're going to Mexico, why not go with new-found friends who can help with paperwork, and know where the best food is?"

Bravo — Wauquiez 36

Aaron & Sherry Wengenheim San Francisco

Noteworthy: Aaron has been sailing most of his life, and has owned Bravo for 10 years. He bemoans the fact they have to return immediately after the rally.

Taya — Island Packet 45

Clifford & Lynne Quesnel Montreal, QC

Noteworthy: The Quesnels' crew are a pair of Siamese cats, Napoleon and Pacha.

At Last — Skye 51

Scott Neal, San Diego

Quote: "I dreamed about owning a Skye 51 for 12 years before buying At Last," says Ha-Ha vet Scott.

Self-Steering and Emergency Rudders

Join us
at the Crew
Party Sept. 8
at EYC

#1

Servo Pendulum with
optional emergency rudder
BEST FOR MOST BOATS

auto-helm

windvane

Auxiliary Rudder/Trimtab

NO LINES —
EMERGENCY RUDDER
PERFECT FOR DAVITS

Saye's Rig

Pendulum trimtab on
main rudder

FOR HYDRAULIC STEERING/HIGH FREEBOARD

SOS

Emergency Rudder

BREAKS DOWN AND
STOWS UNDER DECK

VISIT OUR UPDATED WEBSITE

3,000 BOATS AND MORE THAN 5,000 PHOTOS (added daily)

www.selfsteer.com

FACTORY DIRECT

SCANMAR

INTERNATIONAL

432 South 1st St. • Pt. Richmond, CA 94804
Tel: 510 215-2010 • Fax: 510 215-5005
Toll Free: 888-WINDVANE (946-3826)
email: scanmar@selfsteer.com

Welcome to La Paz!

MARINA DE LA PAZ

FULL SERVICE MARINA

IN DOWNTOWN
LA PAZ

Join us for the
BAJA HA-HA BEACH PARTY

Thursday, November 18, 4-7 pm
at Papas & Beer Beach Club

All new hardwood docks
Dinghy landing with potable water
New protective piling & sheetpile breakwaters
Wireless Internet · and more!

Friendly, helpful, fully bilingual staff

TEL: 011 52 612 122 1646
email: marinalapaz@prodigy.net.mx

www.marinadelapaz.com

Apdo. Postal 290, La Paz, 23000, Baja California Sur, Mexico

— SAILING TO SUNNIER LATITUDES

Misty Blue — Cascade 44
Ken & Mary Ruth Frazee
Friday Harbor, WA

Noteworthy: Ken and Ruth have sailed *Misty Blue* up and down the Oregon/Washington coast several times, up the Inside Passage five times, and once around Vancouver Island.

Jasdip — Passport 40
Crit Dowler, Alameda

Noteworthy: Crit and husband Dan signed up for the '03 Ha-Ha but Dan was diagnosed with stage 4 melanoma before the start. "He died two years ago," Crit explains. "I promised him I'd fiberglass some of his ashes into the boat and carry on. So carry on I must!"

Shemya — Hunter 41
Tom McCarten, St. Augustine, FL

Quote: "I'm looking forward to finally doing some downwind sailing."

Slow Dance — Hunter Legend 37
Bill Sumner, Channel Islands

Noteworthy: Bill plans to cruise Mexico for the next several months with

three friends — Pat Anderson, Darrin Smith and Nat Sumner — returning next spring.

"Our boat is a thoroughbred: she sails like she's running on tracks and points like a hound dog."

Rainbow — Crowther 36 cat
Clifford Shaw, Emery Cove

Noteworthy: *Rainbow* was built in Australia and sailed to San Francisco on an 18-month honeymoon cruise under her first owner, then cruised to Alaska for 18 months under owner #2.

Intrepid — Swan 44 MkII
Carl Bertelsen, Marina del Rey

Quote: "Intrepid is a thoroughbred chomping at the bit to be heading down the coast. We just have to hold on; she will sail herself south."

Flibbertigibbet — O'Day 34
Jim & Betty Adams
Discovery Bay

Quote: "Doing the '08 Baja Ha-Ha was the most fun we ever had! Time to repeat that experience!"

Caprice — Seawind 1160 cat
Dan & Carol Seifers
Point Richmond

Quote: "After sailing across the Pacific and talking to friends who have sailed the Baja Ha-Ha, we decided that this had to be our next 'great adventure.'"

R3 — Beneteau First 42
Randy & Ramona Garrett
Coos Bay, OR

Quote: "Our boat is a thoroughbred: she sails like she's running on tracks and points like a hound dog."

Apeiron — Com-Pac 27/2
David Vecera & Linda Cramer
San Diego

Noteworthy: David and Linda plan to continue south to the Galapagos, then sail home.

Welcome to La Paz

BAJA HA-HA

Beach Party at **Papas & Beer** Beach Club

THURSDAY, NOVEMBER 18TH

mexican folk dancing
live music by jurassic rock
food & drinks from 4-7 pm
door prizes and much more
free for first fifty
2010 baja ha-ha participants
everyone welcome

MARINA DE LA PAZ
SABEEV

VISTA CORAL
MARINA ESTADOS

LA PAZ

www.visitlapaz.org

CLUB DE YATER PALMIRA

COSTABAJA

BAJA HA-HA PROFILES, PT I

Diamond Girl — Beneteau 393

**Larry & Nelda Read
Bellingham, WA**

Noteworthy: Larry and Nelda say they've been boarded twice by the Coast Guard.

Varuna — Pearson 367 Mitchell & Elizabeth West Portland, OR

Noteworthy: Varuna is starting her second career as a liveboard boat, after a 10-year respite in Washington state.

Sarah Jean II — Saga 43 Norm & Beth Cooper Vancouver, BC

Quote: "Too much of a good thing can be wonderful!"

Rocinante — Beneteau First42 Bob Lesnett, Pt. Richmond

Noteworthy: Bob is a retired race car driver taking on a new passion.

Santosha — Catana 471 The Finnerty family Ventura



Meet Tammy, Patrick and Jack of 'Santosha'.

Quote: "You will only regret the things you didn't do, so time to cut the dock lines and live, explore, and sail!"

Tropicana — Gulfstar 60 David Perry, Alameda

Quote: David has earned his living

as an officer in both the Navy and the merchant marine

Duct Tape — Cal 29 Sig & Phyllis Horneman Berkeley

Quote: Phyllis says "The Ha-Ha will reveal new places, new people, and satisfy the sailing addiction. It's a win-win-win."

Sundance — Beneteau M38 Richard Donker & David Remp San Francisco

Quote: "Another check-off on the bucket list."

We'll give it a rest here, and pick up where we left off next month.

In the meantime, if you'd like to meet and mingle with several hundred members of this year's fleet, consider showing up at our Mexico-Only Crew List Party and Baja Ha-Ha Reunion Wednesday, September 8 at Alameda's Encinal YC (6 to 9 p.m.)

— *latitude/andy*

SAL'S

INFLATABLE SERVICES, INC.

ATTENTION OFFSHORE CRUISERS!

**Deadline:
Sept. 6**



FREE, Live, Freshwater Liferaft Safety Class

This is a unique opportunity to get the best possible experience with a liferaft *before* going offshore.

Limited space is available to join an actual liferaft deployment and boarding class immediately preceding the *Latitude 38* Crew List Party.

Location: Encinal Yacht Club pool, Alameda

Date: Wednesday, Sept. 8 **Time:** 3:00-5:00 p.m.

Bring a lifejacket, swimwear, a towel, and dry clothing.

No cost, but reservations and a refundable \$25 deposit are required.

PHONE (510) 522-1824 FAX (510) 522-1064

1914 Stanford Street, Alameda, CA 94501

salsinflatables@sbcglobal.net • www.salsinflatableservices.com

Reserve
Your EPIRB
or Raft Rental
Now!

BAJA HA-HA XVII

**150+
BOATS
SIGNED UP
SO FAR!**

**BROUGHT TO YOU BY
THESE OFFICIAL SPONSORS**

Turn the page for more →

Yachtfinders/Windseakers
in the heart of
San Diego's boating community
Specialists in cruising sailboat brokerage for 28 years
info@yachtfinders.biz • www.yachtfinders.biz
(619) 224-2349 • (866) 341-6189 toll-free
Fax (619) 224-4692

WWW.BAJA-HAHA.COM

The Rally Committee encourages you to patronize the advertisers who make this event possible – and take advantage of their Baja Ha-Ha Specials!

OPEQUIMAR
MARINE CENTER CENTRO MARINO

A Full Service Boat Yard in Puerto Vallarta
88 ton Travelift • Parts • Service • Repairs
011-52 (322) 221-1800 www.opequimar.com
info@opequimar.com

Your Yacht Club
South of the
Border



Home
of the
Banderas Bay
Regatta

Vallarta Yacht Club

<http://vallartayachtclub.org>
<http://banderasbayregatta.com>

Everything you need from a full service yacht club.

ARE YOU READY TO HA-HA?

With the September 10 entry deadline fast approaching, more than 150 boats have signed up for this year's rally, and more are added daily. If you're on the fence about joining this year's southbound migration, we'll remind you that your "To Do List" will never be complete, so don't fall prey to procrastination. As thousands of rally vets would tell you, at some point you've just got to forget the list and "Do it!" You'll find the complete list at www.baja-haha.com.

If you're not familiar with the event, let us explain that the Ha-Ha is a 750-mile cruisers' rally from San Diego to Cabo San Lucas, with stops along the way at Turtle Bay and Bahia Santa Maria.

You'll find frequent updates on this year's event, in addition to all sorts of other hot sailing topics at *Latitude's* 3-times-weekly news portal, *Lectronic Latitude* (found at www.latitude38.com.)

Summer
is safe at
Paradise



Enjoy
your stay
with us!

Paradise Village
BEACH RESORT & SPA

011-52-322-22-66728 • www.paradisevillage.com
marina@paradisevillagegroup.com

**Nautical Books, Software, Charts
and more!**



WAYPOINT

621 - 4th St., Oakland, CA

www.waypoints.com • (510) 769-1547

**RIGGING
ONLY**

Standing and running rigging, lifelines, furlers, winches, headsail poles, main slider systems, windlasses, travelers, wire terminals, blocks and more...
Expert advice for selection and installation.

Our 26th Year! www.riggingonly.com
(508) 992-0434 • sail@riggingonly.com

ICOM

Award-winning Marine Communications Equipment

Handhelds • Mounted VHF • SSB • AIS

Visit one of our many West Coast dealers

www.icomamerica.com/marine

MONITOR
LINEWARE
auto-helm
WINDLASSES

SOS Emergency
Rudder
Saye's Rig

SCANMAR Factory
Direct
INTERNATIONAL

432 South 1st Street • Pt. Richmond, CA 94804
Toll Free: (888) 946-3826 • Tel: (510) 215-2010
email: scanmar@selfsteer.com • www.selfsteer.com

West Marine

Call

1-800-BOATING
(1-800-262-8464)

for a catalog or the store nearest you.



Est. 1973

Almar Marinas

Everywhere you'd like to be
almar.com

BAJA HA-HA XVII



spinlock



The experts in rope handling
and personal safety.

www.spinlockusa.com



MEET THE FLEET

Among the important dates to note (at right) is *Latitude's* annual Mexico-Only Crew List and Ha-Ha Party, September 8. There, hundreds of potential crew mix and mingle with Ha-Ha boat owners who are looking for extra watch-standers. Get a head start on the process at our constantly updated Crew List site at www.latitude38.com. As many Ha-Ha vets will confirm, the best way to prepare for doing the event in your own boat is to crew for someone else first.

VENTURA HARBOR BOATYARD

Full & Self Service Facility

(805) 654-1433

Two Travelifts • Haul Outs to 160 tons

www.vhby.com

Shoreside Work Slips • Emergency Repairs



Let Marina El Cid
Welcome You to Mexico

A Cruiser's Paradise!

www.elcid.com

marinaelcidmizatlan@elcid.com.mx

011-52 (669) 916-3468



Not just a marina – a cruiser's community
Your best destination across the Sea...

www.marina-mizatlan.com

011-52 (669) 669-2936 & 2937

elizarraga@marinamizatlan.com

¿ MEXICO BOUND ?

GERRY

SEA of CORTEZ CHARTS

Accurate Navigation Charts & Guides

ELECTRONIC and PAPER

www.GerryCruise.com

Best Marina in Banderas Bay



MARINA RIVIERA NAYARIT

BY LA CRUISE

www.marinarivieranayarit.com

(52)3221350798

The Ultimate Boat Organization Software

Perfect for the Ha-Ha and all offshore cruising:

- Digitally organize all your boat's documents & specifications
- Store manuals, diagrams, pictures, renewals & registrations
- Keep track of maintenance items required & completed
- Save for quick access all your favorite service providers



www.BoatServiceLog.com

IS THE PACIFIC PUDDLE JUMP IN YOUR FUTURE?

For many cruisers, the next logical step after cruising Mexican waters for a season or more is to hang a right and head west into the Pacific.

We call that annual springtime migration the **Pacific Puddle Jump**, and report on it heavily in the pages of *Latitude 38*. Making that 3,000-mile passage is one of the most thrilling accomplishments in the realm of sailing. Learn more at www.pacificpuddlejump.com.



Survive Your Dream

ECHO Tec Watermakers

604-925-2660

www.hydrovane.com



www.downwindmarine.com

2804 Cañon St., San Diego

(619) 224-2733 • (800) 269-0241



www.sandiegomarine.com

2636 Shelter Island Dr., San Diego

(619) 223-7159 • (800) 336-7369

Mexico 001-500-336-7369



www.sailingsupply.com

2822 Cañon Street, San Diego

(619) 225-9411 • (800) 532-3831

0D36887

Serving Boaters
Since 1959

MARINERS
GENERAL INSURANCE GROUP

Cruise with Confidence

See Our Half-Page Ad In This Issue

(800) 992-4443

www.marinersinsurance.com

Newport Beach, CA • San Diego, CA
Burlingame, CA • Seattle, WA
Bradenton, FL • Puerto Vallarta, MX

BROUGHT TO YOU BY THESE OFFICIAL SPONSORS

WWW.BAJA-HAHA.COM

**CREW
LIST PARTY
SEPTEMBER 8
ENCINAL YC
6-9 PM**



- Ultra Anchors • Ultra Swivels
- Quickline Flat Rope & Reel • Ultra Trip Hooks
- Ultra Chain Grabs, Ultra Snubbers & Ultra Bridles



www.Quickline.us
www.UltraAnchors.us
sales@Quickline.us
 714-843-6964

The Best Marine Products from the World, for the USA.



KATADYN
 MAKING WATER DRINKING WATER

Watermakers that improve the cruising lifestyle.

(800) 755-6701 • www.katadyn.com
 email: marine@katadyn.com



MARITIME INSTITUTE
 INCORPORATED

Advanced Training for safer, more enjoyable passagemaking!

888-262-8020
www.maritimeinstitute.com

USCG Approved **Classroom & Online Courses**



Blue Sky
 ENERGY

'Solar Boost' charge controllers that combine solar/wind/hydro output for cruisers.

(800) 493-7877 www.blueskyenergyinc.com



La Paz Hotel Association

November 18: La Paz Baja Ha-Ha Beach Fiesta on the Malecón at the Papas and Beer restaurant.

011-52 (612) 122-4624
 or **(612) 125-6844**
www.visitlapaz.org

IMPORTANT DATES

Sept. 8 — Mexico-Only Crew List and Baja Ha-Ha Party, Encinal YC in Alameda; 6-9 pm.

Sept. 10 — Final deadline for all entries.

Oct. 16 — Ha-Ha Welcome to San Diego Party, Downwind Marine, 12-4 pm. Ha-Ha entrants only.

Oct. 23 — Informational Meeting about the Pacific Puddle Jump, West Marine, San Diego, 5 pm.

Oct. 24, 9 am — Final deadline for all crew and skipper waivers, West Marine, San Diego.

Oct. 24, 11 am — Skipper's meeting, West Marine, San Diego. Skippers only please.

Oct. 24, 1 pm — Ha-Ha Halloween Costume Party and Barbecue, West Marine, San Diego.

Oct. 25, 10 am — Fleet Parade through San Diego Harbor

Oct. 25, 11 am — Start of Leg 1

Oct. 30, 8 am — Start of Leg 2

Nov. 3, 7 am — Start of Leg 3

Nov. 5 — Cabo Beach Party

Nov. 6 — Awards presentations hosted by the Cabo Marina.

Baja Ha-Ha, LLC
 c/o 15 Locust Ave.
 Mill Valley, CA 94941

WWW.BAJA-HAHA.COM

PLEASE NOTE: There is no phone number for the Baja Ha-Ha Rally Committee. Please don't call *Latitude 38* with questions. The Ha-Ha is a separate operation.



MARINA DE LA PAZ
FULL SERVICE MARINA

Conveniently located downtown

Tel: 011-52 (612) 122-1646
 Fax: 011-52 (612) 125-5900
 email: marinalapaz@prodigy.net.mx
www.marinelapaz.com



BLUE PELICAN MARINE
 Nautical Consignments

A Sailor's Consignment Chandlery

Located at Grand Marina Dealer for Lavac Marine Toilets

www.bluepelicanmarine.com
(510) 769-4858

Dedicated AIS Collision Avoidance



vespermarine

"A really amazing piece of gear. I can tell it was designed by a sailor."

(858) 405-5810
www.vespermarine.com

THE BOAT YARD AT GRAND MARINA

"Where Service Has Meaning"

Located in Alameda **(510) 521-6100**
www.boatyardgm.com



Colligo MarineTM

Bringing innovative solutions to the marine industry.

Colligo DuxTM synthetic standing rigging • Emergency shroud kits
 Bridle plate mooring systems • Furlers and much more.

(480) 703-3675
www.colligomarine.com

MAX EBB

Bang! Crash! Bang! There was no mistaking the sound of the mainsail slatting. We were out of wind.

I had not really planned to get any sleep during my off-watch. In fact it wasn't even an official off-watch, because this was just a one-day race down the coast and watches had not been set. There'd been plenty of wind and we were making excellent time, but the finish could be well after midnight if we hit a calm spot, so I decided to rest in a quarter berth while conditions were stable. Fresh hands might be needed for the approach to the finish, when the wind can get goofy.

Bang! Crash! Bang! The pleasant sound of water bubbling past the hull just a few inches from my ear had disappeared, and another set of swells caused the main boom to fling itself across the boat three or four times.

"Everyone to leeward!" shouted the watch captain. "And you swabs down below, too," someone yelled down the main hatch. "No lollygagging on the high side."

I was not amused. I yawned an expletive but obediently crawled out of one berth and into the corresponding berth on the downhill side. From here I could see Lee Helm at the chart table, dimly lit by the red instrument lights.

"Speed?" I yawned as the mainsail crashed and slatted again.

"Goose eggs," she answered.

"How far to finish?"

"No way we'll get there for dinner. We might even miss the midnight chili."

"Glad I got some rest," I said. "I think most of the crew have been at it since the start. We'll need some fresh talent," I said through another yawn, "to get this thing moving in the light stuff."

"Tee up the windseeker for a peel change," called the watch captain.

"I already told them how to turn all this wave energy into propulsion," Lee said. "But on a boat like this, I only make dissenting suggestions once, then keep it zipped."

It was the expected call. The windseeker is a very light non-overlapping full-hoist jib, with a wind range of "zero to one," according to the sailmaker on board.

I heard the forward hatch slide open, and felt the boat shudder as our biggest foredeck crew jumped down the hatch to pull out the sail. At the same time I

could hear the forward jib lead track being readjusted, and then hear and feel more heavy feet on deck as the change sheet was strung through the block and attached to the clew of the new sail.

The pawls in the big winch right over my head clattered as the slack was taken in, blotting out the sound of the bag unzipping and the head and tack of the sails being pulled out to attach to the new halyard and tack pin.

"Hoist!" I heard the call from the cockpit.

Now there was another winch rattling as a length of halyard tail equal to the full length of our jib luff made its way around one of the halyard winches.

"I wish they would just hand-over-hand it when there's no load," I complained to Lee.

"Boys," Lee shrugged.

There was more noise on deck as the old jib was pulled down.

"Slowly there!" yelled someone on deck. "We can flake it as it comes down."

All this time the mainsail was still slatting from side to side as each set of swells rolled the boat. We must have drifted around so they were coming at us beam-on. I could feel the occasional attempts by the driver to scull the boat back to his preferred course.

A new sound was added to the mix after the lazy running backstay was brought forward, probably to avoid chafe on the main. With each roll of the boat there was a loud clang as it hit the leeward shroud.

Then they tried a tack. Much running around, the amplified clatter of large winches with no load on them, and multiple sculling pulses from the tiller.

The watch captain called down for people below to switch sides again, but Lee said not to bother — which was a

good call because we tacked back after two more minutes of slatting.

"Speed?" I asked Lee again.

"Still goose eggs," she sighed. "Zero point zero."

The mainsail made a particularly loud crash and bang, and some of the water droplets that had condensed on



TEAM GROUPAMA

the plastic and carbon sailcloth shook loose and found their way through the hatch and into my bunk.

"Can't you do something?" I joked.

"I totally already told them how to turn all this wave energy into propulsion," she said. "But that sailmaker guy knows better. On a big boat like this, with the professionals calling the shots, I only make dissenting suggestions once, and then I keep it zipped."

That was out of character for Lee, but she knew the protocol.

Lee turned back to her instruments and I tried to relax despite the crashing and banging. It felt as if we were inside a floating metal fatigue machine.

"What's our ground speed average since we tacked?" demanded a loud voice from the cockpit.

"We're going, like, backwards," Lee added after reading off the time-averaged ground speed and course from the GPS



Slow goin' — On her Jules Verne quest, 'Groupama' was slowed by waves as much as by lack of wind.

chartplotter.

This was all the sailmaker could handle. He announced that he needed some rest, told the crew on deck to do the best they could with what they had, and to let him know as soon as there was any wind at all. He came down into the cabin and found a pipe berth all the way aft.

"Now's your chance," I whispered to Lee.

She nodded, and stepped halfway up the ladder.

"Let's try some different trim settings," she suggested. "First let's put the backstay all the way on to flatten the main as flat as it will go. No runners or checks, we want maximum mast bend."

"Don't we want the sail to be full for light air?" asked the mainsail trimmer.

"No, that just makes it take longer to shed the starting vortex each time the flow reverses," answered Lee, sounding as if she actually expected this to be completely understood by the stockbro-

ker who was trimming the sail.

I could hear the hydraulic pump handle working as the rig tension went up. Then Lee called for the vang to be let off completely and the mainsheet eased, allowing the compressed air in the vang cylinder to lift the boom up a couple of feet higher than where it had been when it was held up by the mainsail.

"This works even better," I heard her explain, "when you hold up the boom end with a 'back lift,' which is a topping lift that goes from a little way up the backstay to the end of the boom."

"We could use the regular topping lift," suggested one of the crew.

"Nah. Gets in the way of the mainsail leech half the time. And we also need to, like, pull the traveler all the way over to one side, and rig a positioner to keep the boom locked on centerline."

"A positioner?" three of the crew asked simultaneously.

"Sure. It's like another mainsheet going to the other end of the traveler. Tie a spare line to the mainsheet bail on the boom, then bring it down to the deck on

the side opposite the traveler car. Then we have three-point support for the boom to totally lock it in place. On centerline and high enough to make the sail megatwisty, but also mega-flat, which we do with mega-mast bend."

"Twisted and flat," repeated the mainsail trimmer. "With boom locked on centerline. Interesting."

"Permanent backstay is at max allowable," reported the crew who had been pumping away at the hydraulics for the last several minutes.

"And outhaul on," added Lee.

I heard what I assumed was the "positioner" being tensioned via the secondary winch over my bunk.

Then the next set of swells started the boat rolling again. The crashing and banging was gone.

"How do you want the jib trimmed?" asked a voice from the cabin top.

"Same way. Flat, twisted and clew on centerline."

"Jib clew on centerline?" questioned the jib trimmer.

"For sure. Didn't you have a toy sailboat when you were a kid, with one jib sheet that went right to the mast? It still worked, right?"

"Okay, I'll try anything once."

"Move the jib sheet lead block way back and put on both sheets," Lee instructed. "And, like, trim those runners away from the mast a little, just so they don't make all that noise. And steer to keep us rolling in the wave troughs."

She had to give the driver, who could not see or sense the direction of the waves, a compass course to steer.

The rolling, of course, only got worse. But the crashing, banging and slatting were almost gone, replaced by a swishing sound as both sails twisted and flopped from side to side like two giant swim fins. And then I heard water moving past the side of the boat again.

"Off the peg!" shouted the mainsail trimmer. "Speed is zero point six and climbing."

The speed continued to build, and there was a group cheer when we hit one full knot. In a few minutes we were averaging about 1.4, with a burst of 1.9 in a particularly steep set of swells.

"Wish we had known about this during Pac Cup this year," remarked the mainsail trimmer. "We broke more gear in zero wind than we did in the squalls."

"I'll bet it works even better on older boats with shallower keels," said another crew, "because they roll more in beam

MAX EBB

seas."

The sound of water moving past the hull brought the sailmaker back on deck.

"I see you guys found a little scrap of wind," he said after he had taken a peek at the knotmeter.

"No, just wave action," they informed him. "But it's enough to get us out of this hole."

When the sailmaker went up, Lee came down and plotted a course that she hoped would take us back into the wind and almost to the finish line without finding another parking lot. She gave the driver a course to steer.

"We're just like a powerboat in this mode," I observed. "This is the first time I've ever heard you give a driver a compass course to steer. Usually it's just 'best VMG' or 'fastest boat speed,' maybe with a modifier like 'sail a little on the fat side' or 'as low as you can go without losing control.' I guess when we're wave powered we can just aim and go."

"Within limits, Max. We still can't go up-wave or down-wave. But the polar sure looks totally different than when

we're sailing."

"My routing software would have trouble with this," I observed.

"Sure would. And as boats get faster, it gets more important to add wave effects to the polars. Take *Groupama* on their round-the-world record trip. They were slowed down as much by waves as by light wind, so the routing was, like, based as much on sea state as on wind forecasts."

"Does this mean we'll need to use a different set of polars for each sea condition? Shouldn't be a problem for a computer."

"It adds three new dimensions at least. Instead of calculating or measuring a speed value for each wind angle times each wind speed, you need a new set of speed predictions for each wave angle relative to the wind, each wave height, and each wave period. If there are n points per dimension, the total number of data points becomes n to the fifth power instead of n squared. We're

talking, like, hundreds of thousands of VPP speed predictions instead of just 50 or 100 to get a set of polars. And that's for a very simple sea state with only regular waves. To do it right you really need a statistical description of the sea spectrum with several parameters. These can probably be deduced from the fetch and with wind field history, but still, it's going to be a whole new ball game in routing software."

We rolled along at 1.4 to 1.6 knots for another hour or so, then found some real wind and changed back to the big genoa. I decided I was "on watch" again and took over for an exhausted trimmer. We could practically smell the chili as we approached the finish line.

Then we hit the kelp.

"Lee, are you going to show them how to make your keel flossing rig?" I asked.

"I already told them how to do it," she yawned. "They'll ask me again when they're ready."

— max ebb

There's No Place I'd Rather Be...

Thanks to BoatU.S. Insurance.

BoatU.S. Insurance gives me such peace of mind, nothing else matters when I'm out here on the water. That's the beauty of a policy from BoatU.S. Insurance specialists work with me helping select the perfect options for my boating lifestyle.

- ◆ Low Rates, Broad Coverage
- ◆ 24/7 Claims Service from Boating Experts
- ◆ Discount for Boating Safety Courses
- ◆ Flexible Payment Plans
- ◆ Policies developed for Boaters by Boaters

If you want truly care-free boating, don't settle for anything less than BoatU.S. Marine Insurance.

BoatU.S.
MARINE INSURANCE

Call **1-800-283-2883**
mention priority code 4848
or apply online at BoatUS.com/insurance.

All policies subject to limits and exclusions. Installment fees apply to payment plans.

New Member Showers and Laundry Facilities Now Open!

Emeryville Marina

ON THE BAY

NEW SLIPS!

Now taking reservations for 40' to 60'

*When you call Emeryville Marina Home...
...call this your backyard!*

Free Wi-Fi and Video Surveillance

Slips from 20-65 ft
Full Amenities - including
Fuel Dock & Pumpout Station

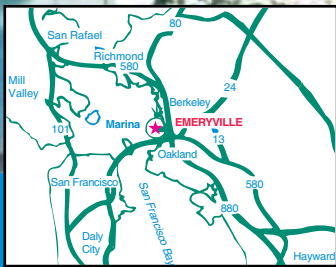

MARINAS
International

(510) 654-3716

www.emeryvillemarina.com

CUSTOM HARD TOPS Power or Sail



Wavestopper hard tops
Full service canvas & upholstery
Dodgers, biminis
Custom molded roof tops
(707) 812-8108
baysidecanvas3@aol.com

Bayside Canvas
serving the entire Bay Area



Port Townsend, WA
since 1975

Featuring:

Port Lights in 316 Stainless Steel, Bronze and Copolymers starting at \$109.95

New full line of inflatables starting at \$596 + free shipping



**See us at the ANNAPOLIS BOAT SHOW
October 7-11**

Deck Wash
Cleats • Handrails
and Other
Marine Hardware



See catalog on the website:

www.newfoundmetals.com

Toll Free: 888.437.5512
nfm@newfoundmetals.com • 360.385.3315

THE RACING

In this month's Racing Sheet, we take a look at the **International Knarr Championship**, then the **Aldo Alessio Regatta**. Following that, we recap a romper-stomper of a **Ronstan Bridge to Bridge**, which took place amidst the **18-ft Skiff International Regatta**. We break up the racing write-ups with an interview with **Dee Smith** before taking a quick look at the San Francisco YC's **Melges Race Week**. We also check in with the **Finn Silver Cup** before reliving the **Santana 22 Nationals** and an **America's Cupdate**. Enjoy!

IKC

The International Knarr Championship came to the Bay August 8-14 and when the deciding final race was finished, the Bay's Jon Perkins came out on top. In finishing eight-points clear of his older brother Chris, Perkins won the event for

the third time — his first on the Bay — to become the second-winningest skipper in the 42-year history of the regatta. Perkins and his crew of Melissa and Tom Purdy and Larry Swift led the regatta from day one and never

Perkins said played to his favor. Perkins and the dynamic sibling duo of Tom and Melissa Purdy have been sailing together in the IKC for the last six years, while Swift was new to the boat this year. While main trimmer Melissa — a Whitbread veteran — and bowguy Tom — an accomplished dinghy and big boat sailor — certainly punch above their weight, they don't pack the pounds like many of the brawny Knarr sailors.

"Being on the Cityfront helped us a lot," Perkins said. "We're about 200 pounds lighter than everyone else, so we enjoy being able to come into the beach and play the shifts."

Perkins and the Purdys finished second in the IKC in Copenhagen, Denmark last year, having come very close to winning it all, and Jon said the weight difference isn't really a downwind advantage. But it isn't always a disadvantage.

"There are big differences between the wood and glass boats," Perkins said. "But even with our weight disadvantage, in a wood boat we do just fine in the breeze because they twist more."

Perkins said his team got a good boat draw. It was the same, incidentally, as his older brother's. All the boats are provided by the local fleet, and each team sails four different boats over the course of the eight-race series. The differences between the boats are pretty big according to Chris Perkins; thus, they are ranked into four different categories, and each team gets a boat from each of the categories during the week.

Chris Perkins took second overall behind his little brother after starting the day tied with Dane Soren Pehrsson, who finished third. The two teams didn't match race each other at the start, which worked in Chris Perkins' favor. After a throwout, Pehrsson dropped a fifth while Perkins dropped a ninth, meaning that if they both beat each other up on their way to the back of the fleet, Pehrsson would come out ahead.

"We just went out there and tried to get a good start," Perkins said. "The Danes were in a boat that I don't think they were comfortable in, and we had a really



LATITUDE/ROB

SERGEI ZAVARIN/WWW.ULTIMATE-YACHTSHOTS.SMUGMUG.COM

LATITUDE/ROB



Jon Perkins

looked back.

"Six years ago here, we were in a similar situation, but we were tied with my brother going into the last race and he ended up winning," Jon Perkins said. "We're really psyched to have pulled it off this year at home."

Perkins said that a comeback in Race 7 was the biggest factor in their win. After getting buried at the start, they fought all the way back to 2nd.

"If we hadn't done that, it would have been a completely different picture (on the final day)," he said.

Out on the race course the 26-boat field saw a westerly breeze most of the week with 4 knots of food. This made getting to the beach essential, something

Third place finishers trimmer Mikael, tactician Soren and skipper Soren Pehrsson, representin' DEN.



LATITUDE/ROB

good boat."

We put that question to Pehrsson.

"No, it was a good boat," Pehrsson said. "Chris had a really good start, and we couldn't get away cleanly."

Pehrsson told us that in Scandinavia, almost all the boats are fiberglass, and all have aluminum masts — something he said the U.S. fleet is considering allowing next year — which makes the boats much more evenly matched. Still, he said the level of the U.S. fleet has improved dramatically since they first started coming here.

"Three years ago here, the top four boats were all Danish," he said, before smiling. "Of course neither of the Perkins sailed that year."

INTERNATIONAL KNARR CHAMPIONSHIP (St. FRANCIS YC 8/8-14, 8r, 1t)

1) **Jon Perkins**, USA, 11 points; 2) **Chris Perkins**, USA, 23; 3) **Soren Pehrsson**, DEN, 28; 4) **Lars Gottfredson**, DEN, 40; 5) **Sean Svendsen**, USA, 50.5. (26 boats)

Complete results at: www.stfyc.org

Aldo Alessio Regatta

The St. Francis YC's Aldo Alessio Re-



LATTITUDE/ROB

The 42nd International Knarr Championship brought out an international field for a bash around the Bay August 8-14. Insets: the only major casualty of the week was a rig; Chris Perkins

gatta drew eight J/120s, 16 J/105s and a nine-boat IRC division July 31- August 1. The latter sailed for the rating rule's West Coast Championship. Scooter Simmons' *Blackhawk* took the J/105 honors on a countback after tying Bruce Stone's *Arbitrage* with 11 points. Phil Laby and Rich Pipkin's *Racer X* finished just three points back.

Barry Lewis' *Chance* finished two points clear of John Wimer's *Desdemona* to win the J/120 division with a bullet in the last race. *Chance* scored a bullet in the last race after the two started it tied on points.

In what had to be just about the closest IRC regatta on the Bay since last year's Rolex Big Boat Series, Dan Woolery's Richmond YC-based King 40 *Soozal* won the IRC West Coast Champion title for the second straight year. Woolery finished only two points ahead of Brad Copper's Tripp 43 *TNT*, which not only won a race, but went into the final skirmish tied on points with *Soozal*. Sy Kleinman's Schu-

macher 54 *Swiftsure II* also won a race — by one second over *TNT* — en route to a third place finish.

St. FRANCIS YC ALDO ALESSIO REGATTA (7/31-8/1, 4r, 0t)

J/105 — 1) **Blackhawk**, Scooter Simmons, 11 points; 2) **Arbitrage**, Bruce Stone, 11; 3) **Racer X**, Phil Laby/Rich Pipkin, 14. (16 boats)

J/120 — 1) **Chance**, Barry Lewis, 8 points; 2) **Desdemona**, John Wimer, 10; 3) **Mr. Magoo**, Steve Madeira, 13. (8 boats)

IRC — 1) **Soozal**, King 40, Dan Woolery, 7 points; 2) **TNT**, Tripp 43, Brad Copper, 9; 3) **Swiftsure II**, Schumacher 54, Sy Kleinman, 13. (9 boats)

Complete results at: www.stfyc.org

Ronstan Bridge to Bridge

A high pressure system had sent temperatures into the stratosphere the day before, killing the breeze. So the Bay retaliated on August 25, exacting its revenge on the f eet

turned out for the Ronstan Bridge to Bridge race.

The breeze peaked in the low 30s and was accompanied by a 3.5-knot ebb for the 7.5-mile classic run from the Gate to Yerba Buena Island, hammering the 57 entries: 37 kiteboarders, 13 Formula boardsailors, 13 18-ft skiffs and Donald Montague's kite-powered foiling trimaran. By the time the safety boats had recovered all the stragglers, only 33 of them had finished. While the Formula boards had the best finishing record of all the disciplines — 12 made it the whole way — it was the 18-ft skiffs that charged into top-three spots overall.

Australians Michael Coxon, Trent Barnabas and Thurlow Fisher on *Thurlow Fisher Lawyers* took a conservative line off the start, staying well-clear of the South Tower Demon — which nearly claimed American Howie Hamlin's brand new 18-ft skiff after a capsize shortly after the start — and rocketed down the course at speeds approaching 25 knots, finishing in just over 24 minutes. Next in were Kiwis Alex Vallings, Josh McCormack and Weta designer Chris Kitchen aboard *CT Sailbattens*, followed shortly thereafter by Aussies Herman Winning, Peter Harris, and Euan McNichol aboard *Appliances Online*. The top kiter was the Bay's Chip Wasson, in fourth, with Aussies John Winning, Andrew Hay and David Gibson aboard the 18-ft skiff *Yandoo* in fifth. Steve Sylvester, the top boardsailor came in sixth.

The attrition included not just the "normal" stuff like broken bowsprits, but also some pretty serious injuries. *Skiffsailing.org* skipper, the Bay Area's Chad Freitas, went to the hospital with suspected broken ribs. *Maersk Line* skipper Kiwi Graham Catley suffered a gash

Donald Montague's trippy-looking, kite-powered foiling tri showed awesome speed in the Ronstan Bridge to Bridge when she was able to stay up on the foils — not an easy task in the ebb chop.



THE RACING

ERIK SIMONSON/WWW.H2OSHOTS.COM



LATTITUDE/ROB



Clockwise from above — Yvonne Galvez, Katie Love and Mallory McCollum finished the first all women's entry in the 18-skiff regatta; the ladies get their old boat moving; the Coxon/Links/Fisher connection won five races, and the regatta; the biggest fleet ever assembled here; 'Thurlow Fisher Lawyers' leads 'Panasonic' down a run; 'Appliances Online' may look like a woody, but she's one of the more advanced boats in the fleet; Pat Whitmarsh, Mark Breen and Joe Penrod sending it in the ebb-induced moguls off Treasure Island.

SHARON GREEN/WWW.ULTIMATESAILING.COM



SHARON GREEN/WWW.ULTIMATESAILING.COM



in his leg that went down to the bone and required a trip to the hospital for 40 stitches after he bled out all over the St. Francis YC locker room's floor after removing his wetsuit. [ed.note: when wearing a compressive garment like a wetsuit while suffering a laceration, basic first responder training says it's best to leave it for the doctor to take off.] Sadly, the pitchpole that led to the injury was avoidable: it was caused by the wake of a large sportfisher out spectating the race (with several well-known Bay Area sailors aboard).

Plenty of skiffs had near-misses and multiple capsizes en route to the finish. The only American skiff to finish, *Tangles' Harken Express*, sailed by the Bay's Pat Whitmarsh, Mark Breen and Joe Penrod had a romper-stomper trip down the Bay,

including two capsizes within sight of the finish.

"We got outside the Gate and we were like, 'What are we doing here?'" Whitmarsh said.

The trio managed to get all the way down near Treasure Island before their first flip, but the trip there wasn't exactly routine.

"At one point both Pat and I were in the water dragging behind the boat," Penrod said. "It was my second time off the boat in thirty seconds, but Mark reacted quickly, grabbed the tiller and oversheeted the main and the spinnaker so we could get back on board."

"I knew there was something wrong when I looked around and realized I was the only guy on the boat," Breen joked.

RONSTAN BRIDGE TO BRIDGE (ST. FRANCIS YC 8/25, 1)

OVERALL — 1) **Thurlow Fisher Lawyers**, Michael Coxon/Trent Barnabas/Thurlow Fisher; 2) **CT Sailbattens**, Alex Vallings/Josh McCormack/Chris Kitchen; 3) **Appliances Online**, Herman Winning/Peter Harris/Euan McNichol; 4) **Chip Wasson** (kite); 5) **Yandoo**, John Winning/Andrew Hay/David Gibson. (57 boats, boards or kites)

Complete results at: www.stfyc.org

18-ft Skiff Regatta

One of the Bay's most reliable spectacles, the 18ft Skiff International Regatta, hosted by the St. Francis Yacht Club brought some of the world's best skiff sailors to the Bay August 22-26. Aussie Michael Coxon, on his first visit here, overcame a stumbling entrance by winning five of the last eight races to hold



ERIK SIMONSON/WWW.H2OSHOTS.COM



SHARON GREEN/WWW.ULTIMATESAILING.COM

ERIK SIMONSON/WWW.H2OSHOTS.COM



off another Aussie, Herman Winning, who incidentally won three, by a solitary point.

Howie Hamlin, an original instigator and two-time winner of the event, won the other race in a mid-regatta move before falling victim to the nature of the class that lives on the edge of catastrophe — in this case three crashes including one instigated by Winning and, indirectly, Coxon.

"I'm really impressed with Michael Coxon's sailing," Hamlin said. "He's never been here and he comes in and figures it out right away."

A two-time winner of the JJ Giltinan International Trophy, the 18s' world championship, Coxon sailed *Thurlow Fisher Lawyers* with a confident crew of Aaron Links and Trent Barnabas, who

have won three and five Giltinans as crew, respectively.

"It's hard to overtake boats, there are no passing lanes," Coxon said. "But the biggest thing is staying upright. It's a different thing over here. It's great to beat these guys in their home waters, and it was really special winning the Bridge race."

The 10-race series became a nine-race series when Wednesday's first race was abandoned — the first time in the nine-year history of the event when the mogul field off Alcatraz became a graveyard for 18-ft skiffs, with six capsizing where the 30-plus knot breeze met the 3.5-knot ebb. One, Jonathon Whitty, Tom Anderson and James Hozack's *Panasonic*, broke their rudder right at the waterline.

"We didn't even go out because we

knew it wasn't going to be a race," said *Tangles' Harken Express* skipper Patrick Whitmarsh. "It was validating when they called it."

The race seven abandonment set up Coxon and Winning for a showdown deadlock, each with 11 points, going into the last race. Just after the gun went off, all three were sailing on starboard tack toward the seawall fronting the St. Francis YC when Hamlin, on starboard, and Winning, on port, collided, flattening Hamlin's *CST Composites* and sending crew Matt Noble and Fritz Lanzinger in the water.

Back at the Crissy Field staging area, Winning explained.

"We had Coxon to leeward of us, and normally when you get close to the shore you can call 'water,' which means the boat

THE RACING

above you has to tack, and he was calling it on us. I thought it was too early, but we then called it on Howie [because] it's a basic rule and we all have to abide by it. In hindsight, we definitely should have ducked Howie."

He said he expected even the easy going Hamlin to be steamed, and he

was right. After Hamlin and his crew hauled their skiff ashore, Winning approached and was first met by veteran crew member Fritz Lanzinger as Hamlin tidied up some gear. They all engaged in several minutes of animated discussion of the incident, and then parted with cool handshakes.

But perhaps the best story to come out of the event was that of the American boats. Six of the ten boats on the continent showed up for the event, chief among them the five Bay Area boats. The Bay Area fleet added another this year in the form of Skip and Jody McCormack's *Harken Black*, recently acquired from Team Pegasus. The McCormacks, who you might remember just finished sailing their Mumm 30 doublehanded to Hawaii in this year's Pacific Cup, teamed up with Paul Allen and on little practice managed to finish 10th in the 14 boats fleet, just behind the Bay's Whitmarsh, sailing with Mark Breen and Joe Penrod.

This year was the first year there was an all-womens team. Mallory McCollum-Bozina, Yvonne Galvez and Katie Love dragged out a beat up, leaky, old Grand Prix boat owned by the Skiff Sailing Foundation, and managed to at least get part way around the course on multiple

Miami-based sailor Luke Lawrence leads Southern Californian Caleb Paine down a run at the '10 Finn Silver Cup hosted by St. Francis YC.

days. Although they scored no finishes, the drastically underweight trio dubbed "Chad's Angels" after Skiff Foundation president Chad Freitas, were able to keep the powerful boat upright much of the time despite only having 10 days practice together on the eighteen.

"Our boat is really old," Love said. "But the guys in the foundation have first crack on the newer boats, because they have definitely paid their dues."

Galvez — whose husband Paul is an accomplished I-14 sailor who crewed for Freitas along with McCollum's husband Trevor Bozina — said it was a little nerve-racking to hear the boat make popping sounds while they were sailing. On the first day, the T-ball fittings on the lower shrouds zippered all the way through the bottom part of the rig, and they experienced multiple other gear failures on the boat throughout the week.

"It's one of those thing," Yvonne Galvez said. "When you have confidence in the boat you can push harder and not worry about breaking things. We'll get there."

Love, who grew up sailing Lasers with McCollum on the Bay had previously crewed with Galvez on I-14s, so when she went calling around to find a couple girls to make a team, she knew who to talk to.

"I kept trying to find people," Love said. "Before I convinced these two, no one else either had time, or desire, and I was just nuts enough to keep going."

18-FT SKIFF INTERNATIONAL REGATTA (ST. FYC 8/22-26, 9r, 1t)

1) **Thurlow Fisher Lawyers**, Michael Coxon/Aaron Links/Trent Barnabas, 10 points; 2) **Appliances Online**, Herman Winning/Peter Harris/Euan McNichol, 11; 3) **Yandoo**, John Winning/David Gibson/Andrew Hay, 20; 4) **CST Composites**, Howie Hamlin/Fritz Lanzinger/Matt Noble; 5) **CT Sailbattens**, Alex Vallings/Chris Kitchen/Josh McCormack. (14 boats)

Complete results at: www.sfyf.org

An Interview With Dee Smith

Tooling around the San Francisco YC during the Melges Race Week last month, we saw a familiar face in the crowd of assembled coaches and sailors. After a double-take we realized it was Bay Area product Dee Smith, so we cornered him on a two-year-old promise for a quick interview.

LATITUDE/ROB



Dee Smith



ERIK SIMONSON/WWW.H2OSHOTS.COM



ERIK SIMONSON/WWW.H2OSHOTS.COM

Smith has sailed at the highest levels of the sport in everything from the Admiral's Cup to America's Cup campaigns and the Southern Ocean legs of the Volvo Ocean Race: frankly he's done too much to mention. He's also carved out a career as a coach and project manager that spans much of the sport's continuum right up to some of the largest maxi boats of the last decade. Smith knows how to win, and you'd be hard-pressed to find someone more tactically adroit at coming out of heavy traffic looking golden. Before all that, Smith was a part of the late Carl Schumacher's breakthrough win at the '79 Quarter Ton North Americans that sent the designer on a path to recognition. Smith is a Bay Area guy through and through, but he's called Annapolis home for the last decade or so. A few years ago Smith was diagnosed with an aggressive lung cancer — he was never a smoker — that put everything on hold for awhile and very nearly had him knocking on heaven's door. A couple years back we asked for an interview, and he declined, saying that

LATITUDE/ROB





Clockwise from top left — The Melges 32s blast downwind at Melges Race Week; a Melges 24 gets heeled over like the 'North Face'; not a reassuring thing to see from a committee boat; the 32s just flat-out fly when the breeze gets up.

he'd rather wait until he was back to work again. Well, we caught him back at work, which has taken on a new meaning as Russell Coutts has tapped him to be the North American agent for his brainchild, the RC 44 — one of the world's few grand prix classes that's poised to finally start making inroads into the U.S.

Latitude 38: So how's your health these days?

Dee Smith: I've been dealing with some different health situations, but I've been lucky with the cancer. The first bone fusion I had done in Spain a few years ago had to be redone in February and I'm just getting back to work. Right now I'm here working with Pieter Taselaar's Melges 32 team *Bliksem* on the Bay's local knowledge. I'm also working on getting the RC 44s off the ground in the States. I've sold three so far, two in Europe and one in the

U.S. We've got a circuit of U.S. regattas coming up starting in Miami in December and then on to San Diego in March.

38: Tell us a little more about the boats.

DS: They're marketed as a boat for the top, but anybody can sail them; we're trying to get the message out that it's a really good, fun boat with an incredibly good feet organization. (ed. note: almost all the logistics of boat transport, setup and regatta support are handled by the class.) They're the Formula 1 of feet racing. The boats are built in Europe, so depending on the exchange rate, they cost about the same to get to the starting line as a Farr 40. But for your money, you get an all-carbon boat that will last forever. They're a

lot cheaper to store and ship because they fit on a container-sized cradle; they're actually cheaper to ship across country than a Melges 32, unless you do that yourself. The electronics come with the boat and can't be changed, so there's no extra money spent there and you don't need a full-time B.N. because the boat is so easily stored when it's not sailing. The sails are a lot bigger, but you only have one more pro than a Melges 32. They're so powered up you can race them in three knots of wind! Two people can pick up the carbon fiber keel fin and mast. The boat weighs 7,850 pounds and 4,850 of it is in the bulb.

38: What else do you have going on right now?

DS: Hap Fauth brought me in to get his R/P 69 mini-maxi *Bella Mente* program going in the right direction. He's a fantastically positive person and looked at the modifications we were forced to make [ed. note: they included an entirely new hull abaft admiships, shorter rig and new sails] as a learning experience. Once we made the changes we started winning immediately. After a successful year-and-a-half we're getting to the point where we've maximized the boat and I think Hap is thinking about building a new one. Other than that I've been sailing with a TP 52 program in Annapolis.

38: Speaking of Annapolis, how do you like it out there?

DS: I really like the friendly, warm people. I don't like the weather. Fall and spring are beautiful but the summers and winters are hard. I miss the mountains and the Bay and the people here.

38: Speaking of the Bay, why do you think high-end big boat sailing is so depressed here as of late?

Luke Lawrence brandishes the Stars & Stripes after his win at the Silver Cup. Might he reprise this pose at an Olympic Games somewhere down the road? That's probably down the road a ways, but he's off to a good start. Rio '16 anyone?



THE RACING

DS: There's a lack of high-end experience at the pro realm in bringing new owners into the sport. Us older guys have gone on to greener pastures because if you want to sail in the good f eets, you have to go where they are and where the money is. There's a younger pro group coming up here that is making inroads — they're excellent people and sailors, and they'll fuel the next wave here. The economic situation here doesn't help. I've been staying in the City this week and I'm amazed at how slow it is! You remember what it was like 10 years ago. You couldn't even get into the Balboa Cafe on a weekend night. I went in there this weekend and it was empty. People with money are fleeing California. It takes something to make something, you have to have something for people to want to get into the sport. That's not to say you can't do it, but you have get to a certain mass before it will.

38: What else needs to happen to get more interest in the higher end of the sport?

DS: Three things. We've got to get away from the Corinthian model of non sponsorship. Second, I was just at a pro-am regatta on Nantucket in IODs, and everyone was talking about what nice boats they are. They are nice boats, but you don't really ever have to make any quick decisions or be thinking a few moves ahead, like you do on faster boats. I think that maybe people are scared of sailing these types of boats; we need to re-educate the sailing population in America. The third is the issue of crew: owners have

to be willing to get and train a consistent group of crew. [ed. note: the advent of the Farr 40 and its mixed pro-am model — a cost-saving measure — had a side effect of elevating the game of a whole cadre of amateurs.]

38: What's your take on IRC?

DS: IRC is good at what it was meant to do, and that's to be a club racing rule for existing boats. We have good racing under it in the mini-maxi class but the boats are all new and were all built to the typeform. IRC is the best salesman for my RC 44. Under the rule, above 50 feet you can have a fast boat, but below that you have to have a slow, heavy boat. Would you like to sail upwind and downwind around a course at 7.5 knots, or would you rather sail upwind at 8 knots and downwind at 25?

38: Between IRC, ORR and ORC, there are sure a lot of rules out there. Is that helping or hurting?

DS: The reason we don't have good international big boat sailing right now is that the Australian events are mostly IRC, while the TransPac and Bermuda Race are ORR and many of the events in Europe are sailed under ORC. How do you configure your boat between those three rules? Why would you want to spend the money? Owners are tired of spending useless money to do it. First off, standardize the way they measure sails! But what we really need to do is throw all the rules away and have someone who everyone respects come up a with an open, pub-



ERIK SIMONSON/WWW.H2OSHOTS.COM

Just some more planing porn from the San Francisco YC's Melges Race Week August 20-22. Does that look fun to you? It does to us.

lished rule for everyone. The secret rules that change every year are dumb, because we all know what will make a boat go fast and rate well under them. We need to accept that it will typeform, and lock the rule in for five years right off the bat; you need that kind of stability and you

THE BOX SCORES

We don't have the time or manpower to chase down all the results, so please post them on your club's website or send them directly to the Racing Editor at rob@latitude38.com. Our format is to include the name of the boat, the type and length of boat, and the first and last names of the owner(s). We'll do our best to get that info into *Latitude 38* and *Lectronic Latitude*.

WEEKEND:

SFYC SUMMER KEELBOAT REGATTA (8/14-15, 5r, 0t)

EXPRESS 37 — 1) **Golden Moon**, Kame Richards, 12 points; 2) **Eclipse**, Mark Dowdy, 13; 3) **Elan**, Bill Riess. (5 boats)

J/105 — 1) **Arbitrage**, Bruce Stone, 11 points; 2) **Jam Session**, Adam Spiegel; 15; 3) **Donkey Jack**, Rolf Kaiser, 24. (15 boats)

Complete results at: www.sfyc.org

SOUTH BEACH YC J/120 & IRC REGATTA (8/21-22, 4r, 0t)

IRC — 1) **Soozal**, King 40, Dan Woolery, 10

points; 2) **Inspired Environments**, Beneteau 40.7, Timothy Ballard, 11; 3) **Tupelo Honey**, Elan 40, Gerry Sheridan, 13. (7 boats)

J/120 — 1) **Mr. Magoo**, Steve Madeira, 7 points; 2) **Chance**, Barry Lewis, 9; 3) **Desdemona**, John Wimer, 11. (7 boats)

Complete Results at: www.southbeachyc.org

WEEKNIGHT:

OAKLAND YC SWEET 16 SERIES CUMULATIVE (5r, 2t)

PHRF ≤ 150 — 1) **Golden Moon**, Express 37, Kame and Sally Richards, 3 points; 2) **Cassiopeia**, Islander 36, Kit Wiegman, 8; 3) **JetStream**, JS9000, Dan Alvarez, 9. (8 boats)

PHRF 151-200 — 1) **Popeye & I**, Cal 9.2, Ruth Summers, 3.5 points; 2) **Morning Dew**, Kiwi 29, Vince Boley, 3.5; 3) **Lelo Too**, Tartan 30, Emile Carles, 8. (6 boats)

PHRF 201+ — 1) **Chile Pepper**, Santana 25, Dave Lyman, 5 points; 2) **Blueberry**, Nonsuch 22, John Foster, 6. (2 boats)

MULTIHULL — 1) **Triple Play**, F-31, Richard Keller, 3 points; 2) **Sunbow 3**, Corsair Sprint 750, Ken Johnson, 4; 3) **Rice Rocket**, Corsair 750,

Gary Helms, 9. (3 boat)

NON-SPINNAKER — 1) **Iskra**, Mercury, Paul Mueller, 3 points; 2) **Torrid**, Aphrodite 101, Larry Westland, 5; 3) **Kiwa**, Ericson 32-2, Warren Taylor, 5. (5 boats)

COLUMBIA 5.5 — 1) **Sea Biscuit**, Peter Szaz, 4 points; 2) **Alert**, Liem Dao, 4; 3) **Wings**, Mike Jackson, 6. (5 boats)

MERIT 25 — 1) **Bewitched**, Laraine Salmon, 3 points; 2) **Dire Straits**, J/24, Robin Ollivier, 6; 3) **Bandido**, George Gurrola, 7. (=4 boats)

Complete results at: www.oaklandyachtclub.org

ISLAND YC ISLAND NIGHTS SUMMER '10 #2 (8/6)

PHRF < 168 — 1) **JetStream**, JS9000, Dan Alvarez; 2) **Uno**, Wyliecat 30, Steve Wonner; 3) **Wile E Coyote**, Express 27, Dan Pruzan. (6 boats)

PHRF 168 RATERS — 1) **Bandido**, Merit 25, George Gurrola; 2) **Phantom**, J/24, John Guilford; 3) **Bewitched**, Merit 25, Laraine Salmon. (5 boats)

PHRF > 168 — 1) **Lelo Too**, Tartan 30, Emile Carles; 2) **Wuvulu**, Islander 30, John New; 3) **Tinker**, Wilderness 21, Matthew Beall. (3 boats)

SANTANA 22s — 1) **Spitfire**, Tom McIntyre; 20



shouldn't be dingling someone for coming up with a good idea. I've had some good conversations with (US Sailing President) Gary Jobson about this and he's on it. But most of all, you have to make the people buying the boats happy.

Melges Race Week

The San Francisco YC and PRO Vicki Sodaro hosted an extremely competitive

Melges Race Week on the Berkeley Circle August 20-22. The final installment of the three-regatta Melges California Cup, the event featured 11 Melges 24s and 13 Melges 32s. Sailed in breeze that ranged from the mid-teens to the mid-20s with the attendant Circle slop, the regatta proved a test for both designs, which are definitely designed to be powered up in the light-to-medium range.

There were plenty of spectacular wipeouts, and the fog line that teased the racecourse throughout the weekend provided ample opportunity for passing lanes.

Ten of the 24s were absolutely crushed by Dan Kaseler's *pTeron* which finished with a 3-1-1-1-1-1-2 to win the regatta by a whopping 26 points. Second, third and fourth places were separated by a point between them.

Former Melges 24 sailor and part-time Bay Area resident John Kilroy, Jr. and his *Samba Pa Ti* won the Melges 32 division, which was replete with some of the world's top talent, including multiple Volvo Race winner and *Samba* tactician Stu Bannatyne.

Other heavyweights in the fleet included America's Cup vet Tony Rey, and John Porter, who won the class at the Rolex Big Boat series two years ago and has a couple significant Melges 24 titles to his name.

The standing world champion Pieter Taselaar's *Bliksem* finished second with young Aussie pro sailor and *Morning Light* skipper Jeremy Wilmot showing Taselaar the way. With the build-up to the class's Worlds immediately following the Rolex Big Boat Series, there was a large coaching presence out there for what's become America's only truly grand prix class. It seemed as if there were almost as many RIBs at the dock at SFYC as there were Melges 32s.

MELGES RACE WEEK (SAN FRANCISCO YC 7/20-22, 8r, 1t)

Atuna Matata, Bill King. (2 boats)
NON-SPINNAKER — 1) **Svenska**, Peterson 34, Fred Minning. (1 boat)
Complete results at: www.iyc.org

SOUTH BEACH YC FRIDAY NIGHT SERIES SECOND HALF (CUMULATIVE) (5r, 1t)

SPINNAKER (PHRF ≤ 99) — 1) **Jolly Mon**, J/105, Chris Chamberlin, 5 points; 2) **Alpha Puppy**, 1D35, Alex Farrell, 13; 3) **pHat Jack**, Express 37, Bob Lugliani, 17. (7 boats)

SPINNAKER (PHRF 100+, 2r, 0t) — 1) **North-ern Light**, Santana 35, Rod Neathery, 5 points; 2) **Highlighter**, Islander 36, William Hackel, 9; 3) **Spirit of Elvis**, Santana 35, Martin Cunningham, 11. (10 boats)

NON-SPINNAKER (PHRF ≥154 2r, 0t) — 1) **007**, J/105 Bruce Blackie, 5 points; 2) **Carmelita**, Catalina 42, Christian Lewis, 6; 3) **Rollover**, Catalina 34, Lynn Guerra, 13. (11 boats)

NON-SPINNAKER (PHRF 155+ 2r, 0t) — 1) **Star Ranger**, Ranger 26, Simon James/Tim Walsh, 4 points; 2) **Synergizer**, Ericson 28, Larry Weinhoff, 8; 3) **Double Play**, Yankee 30-2, RDK Partners, 12. (7 boats)

CATALINA 30 (2r, 0t) — 1) **Huge**, Bill Woodruff/Tanya Keen/Peter Birch/Russell Houlston, 6 points; 2) **Adventure**, Jack McDermott, 8; 3) **Dancing**

Bear, Joe Askins/Ray Hall, 11. (11 boats)
Complete results at: www.southbeachyc.com

SAUSALITO YC SUMMER SUNSET SERIES # 3 (8/24)

SPINNAKER — 1) **Roxanne**, J/105, Charles James; 2) **Ohana**, Beneteau 47, Steve Hocking; 3) **Hazardous Waste**, J/105, Chuck Cihak. (6 boats)
NON-SPINNAKER — 1) **J Hawk**, J/133, Dale Fleming. (1 boat)

Complete results at: www.syconline.org

TIBURON YC FRIDAY NIGHT RACING #14 (7/16)

DIVISION 1 (PHRF < 162) — 1) **Natural Blonde**, J/105, Bobby McInerney; 2) **Miramar**, Frers 41, Jeff Brucia; 3) **Hurricane Gulch**, C&C 33 Richard Selmeier. (44 boats)

DIVISION 2 (PHRF >163) — 1) **Siento El Viento**, C&C 29, Ian Matthew; 2) **Meritime**, C&C 30, Gary Proctor. (2 boats)

Complete results at: www.tyc.org

GOLDEN GATE YC FRIDAY NIGHT SERIES #8 (8/13)

SPINNAKER — 1) **Pajarito**, Ranger 23, Joe Sheehy; 2) **Late Harvest**, J/120, Modern Sailing; 2) **IF and only IF**, Folkboat, Gary Fung. (4 boats)

NON-SPINNAKER — 1) **Mary Belle Bright**,

Coronado, Bright Winn; 2) **Snafu**, Canadian Sail, Maurice Quillen; 2) **Top Cat**, Nonsuch 30, Sal Balisteri. (4 boats)

Complete results at: www.ggyc.com

CORINTHIAN YC FRIDAY NIGHT SERIES # 20 (8/20)

NON SPINNAKER 3 — 1) **Chica**, Cal 20, Ted Goldbeck; 2) **Roadrunner**, Ranger 23, Gregory Demetruilas; 3) **Sweet Reward**, Santana 22, Craig McDow. (3 boats)

NON-SPINNAKER 1 — 1) **Willow**, Centurion 40s, Bob Braid; 2) **Q**, Schumacher 40, Glenn Isaacson; 3) **Jarlen**, J/35, Robert Bloom. (7 boats)

NON SPINNAKER 2 — 1) **Seaya**, Catalina 380, Mark Thompson; 2) **Mimicat**, Hincley 38, Robert Long; 3) **Summer Sailstice**, Ranger 33, John Arndt. (6 boats)

J/105 — 1) **Donkey Jack**, Rolf Kaiser. (1 boat)
SPINNAKER 2 — 1) **Yucca**, 8 Meter, Hank Easom; 2) **Shenanigans**, Express 27, Bill Moore; 2) **Nothing Ventured**, Melges 24, Duane Yoslov. (5 boats)

SPINNAKER 3 — 1) **Spirit**, Alerion 28, Nancy Rogers; 2) **Wuda Shuda**, Soverel 26 OB, Craig Page; 3) **Big Wow!**, Rhodes 19, William Royall. (3 boats)

Complete results at: www.tyc.org

THE RACING

MELGES 24 — 1) **pTeron**, Dan Kaseler, 11 points; 2) **12happythoughts**, David Brede, 37; 3) **Personal Puff**, Dan Hauserman, 38. (11 boats)

MELGES 32 — 1) **Samba Pa Ti**, John Kilroy Jr., 17 points; 2) **Bliksem**, Pieter Taselaar, 24; 3) **Warpath**, Steve Howe, 29.60. (13 boats)

Complete results at: www.sfyf.org

Finn Silver Cup

Luke Lawrence won the 2010 Finn Silver Cup, the class's junior world title, on August 24. Remembering the milestone will no doubt be easy as it coincided with the Miami sailor's 20th birthday. Lawrence got off to an early lead in the nine race, one-throwout regatta, which started on August 20 and was sailed exclusively on the Central Bay.

"Winning this event was my main goal this year," Lawrence said. "I have trained hard since spring with my coach John Bertrand. My learning curve has been great. It has been quite stressing at time with difficult sailing conditions and good competition. I am happy because I was able today to go out there and do the job!"

The final race started after a general recall. Coinciding with a record-setting



LATITUDE/ROB

Michael Andrews, with crew Shawn Grassman and Wayne Best won the '10 Santana 22 Nationals.

heatwave, the race was run in light and fuky conditions that saw the regatta lead change during the race. Southern Californian Caleb Paine was first to the top mark while Lawrence rounded in 11th

place. The run against the ebb provided the biggest opportunities to gain or lose. While the top five sailed the run down the middle of the course, Aussie Oliver Tweddell and Lawrence went close to the shore and reaped the benefit of the current relief while making big gainers.

Lawrence ended up taking the title by a scant three points from European Junior champion, Greek Ioannis Mitakis and Tweddell — sailing in his first Finn event after starting sailing the boat only four months ago.

FINN SILVER CUP (ST. FRANCIS YC 7/20-24, 9r, 1t)

1) **Luke Lawrence**, USA 22 points; 2) **Ioannis Mitakis**, GRE, 25; 3) **Oliver Tweddell**, AUS, 26.5. (15 boats)

Complete results at: www.stfyf.org

Santana 22 Nationals

The 14 Santana 22s that showed up at Encinal YC July 31-August 1 for their nationals were rewarded with great breeze for the five-race series sailed on the Emeryville flats.

A look at the race scores suggests that

STAY FOCUSED WITH OUR EYE SAFE NO-STING FORMULA



Z Blok sunscreen's new non-greasy formula will not burn or irritate your eyes. So you can concentrate on winning the race or just enjoying a great day on the water. Z Blok is also fragrance free.

Z Blok is the official sunscreen of the PUMA Ocean Racing Team. Skipper Kenny Read said:

"The UV protection is excellent. Every member of the team is a true believer. We have put Z Blok to a tough test that few others can. Most importantly, we have experienced no eye stinging or irritation and we use it every day."

Visit zbloksun.com or call 508.995.9511

OFFICIAL SUNBLOCK OF THE PUMA OCEAN RACING TEAM

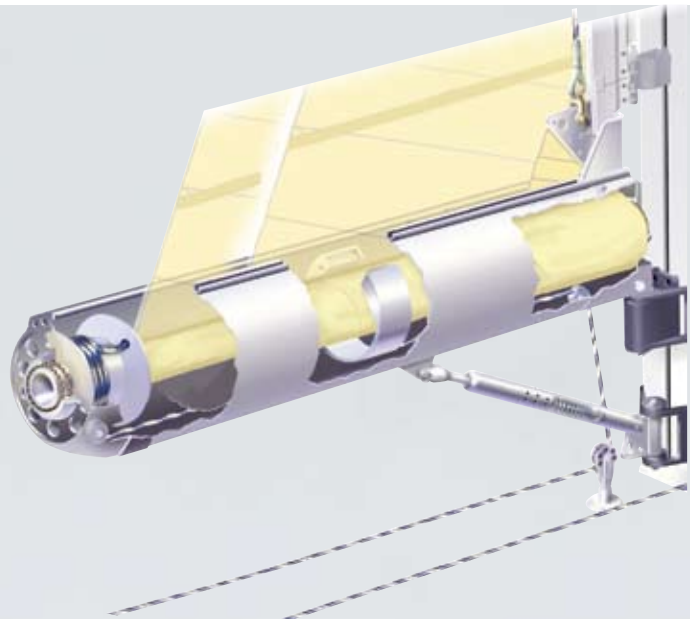

FURL ON THE FLY.

With Schaefer's innovative boom furling system and patented articulating sail track, you can reef your main on any point of sail - all from the safety of the cockpit. Trouble free reefing and furling - just what you would expect from Schaefer Marine.

SCHAEFER
LEGENDARY STRENGTH

508.995.9511
SCHAEFERMARINE.COM

Encinal YC's Michael Andrews, with crew Shawn Grassman and Wayne Best on *Bonito* won going away, but according to the sailors, it was a lot closer than that for the multiple national champions.

The trio started off the regatta by winning Saturday's three races. The deltas were very close, with only seconds separating the top three for many of the races.

"It was very close all day," Andrews said prior to Sunday's racing. "The fact that we have three serious contenders and this many boats is great for the class."

Runner-up and '09 Season Champion Tom Montoya's *Meli'ki* posted a pair of bullets on Sunday to finish three points behind *Bonito* and five ahead of third-place Mike Kennedy's *Pariah*.

A highlight of the post-race activities was a visit by class patriarch Ernie Rideout, who won the regatta two years ago and finally retired from boat ownership this year when he donated his boat — at the age of 93!

SANTANA 22 NATIONALS (ENCINAL YC 7/31-8/1, 5r, 0t)

1) **Bonito**, Michael Andrews, 7 points; 2) **Meli'ki**, Tom Montoya, 10; 3) **Pariah**, Mike Kennedy, 15. (14 boats)

Complete results at: www.encinal.org

America's Cup-date

So how much do you wanna bet that the match for the 34th America's Cup will be sailed on San Francisco Bay? In the wake of news on August 24, that the City would not seek a one-time exemption from the California Environmental Quality Act for the infrastruc-



ERIK SIMONSON/WWW.H2OSHOTS.COM

The Tuna fleet doing what it does best — blasting along on a breezy, sloppy Bay.

ture improvements necessary for a Cup village, we are all but certain that the next Cup match will be held in Europe. In case you missed it, this editor made a rather

TO DEFEAT BLOOD CANCER IT WILL TAKE THE BEST SCIENTISTS, THE TOP DOCTORS AND THE FINEST LABORATORIES. NOT TO MENTION, A CREW OF SAILORS.

Raise a sail to find a cure. The fifth annual Leukemia Cup Regatta benefiting The Leukemia & Lymphoma Society is October 2nd and 3rd at The San Francisco Yacht Club in Belvedere, CA. VIP dinner featuring America's Cup champion, Russell Coutts.

Register at: leukemicup.org/sf



THE
**LEUKEMIA
CUP
REGATTA**

The Leukemia & Lymphoma Society

Photo courtesy of David Dibble

THE RACING

lackluster appearance on KQED's *Forum* the previous Friday morning, at which time the Mayor's office — represented by Kyri McClellan — made it very clear that they would be going after the one-time exemption to the environmental review required by the CEQA.

So why the change of heart? We're guessing that Mayor Newsom has wisely realized that the chances of the 34th America's Cup coming to the Bay are so slim that it's not worth pursuing the exemption. The environmental community has rightly argued that one-time exemptions — the first of which was enacted last October for the City of Industry's bid for an NFL team — represent a slippery slope for the state, as they create an opportunity for big-business to circumvent environmental protections.

With BMW Oracle Racing giving the City a September 30 draft-plan deadline in the middle of August, the keystone CEQA exemption would have been a monumental, if not impossible, undertaking. According to McClellan, the bill would have had to be introduced and signed by the end of the legislative session on



LATITUDE/ROB

The first three of the St. Francis YC's 10 brand-new J/22s slated for team racing have arrived.

August 31.

With pretty much all other pending legislation finalized, this would have meant that the exemption would have

been a stand-alone bill — introduced in the last seven days of the session, and extremely challenging to pass. As of August 20, McClellan said that the City had been talking with some of the Bay Area's representatives in Sacramento in order to find one willing to introduce the bill. In attempting to make the case for the exemption in an article in the *Chronicle* last week, Newsom argued that there was no way the Cup would come to the Bay without the exemption.

He's right. But what Newsom either didn't realize, or felt he couldn't acknowledge at the time, was that even with the exemption, there is a very small chance that the match for the 34th Cup will come to the Bay.

Much of the debate has pivoted on what we believe is the correct view that Larry Ellison would like to see the Cup contested on the Bay. But we just don't think it's as simple as that. Ellison has a day job and so has delegated the running of the team to his CEO, Russell Coutts. We can't imagine Coutts would have signed on without making it clear that

PV11 DEL REY YACHT CLUB PRESENTS
PUERTO VALLARTA RACE SERIES
 MARINA DEL REY TO PUERTO VALLARTA
 2.11.2011

EARLY ENTRY DEADLINE OCTOBER 15: \$200 DISCOUNT!

310.823.4664 www.PV11.org

McGinnis Insurance
 Since 1972

Knowledge Commitment
Reliability Service

Large and small, we do them all!

Call us at: **800-486-4008**
mginnsins@aol.com

License #0570469

all the decisions were his and his alone as he attempts to realize the vision he first thought — incorrectly — he would be seeing through with Ernesto Bertarelli in '07 with AC 32.

If Coutts and Ellison were concerned solely with defending the Cup, they would host the event here in a heartbeat, as an event on the Bay would likely bring fewer challengers into a venue with some distinct hometown advantages. But it would seem that both have an abiding interest in doing what's best for the Cup. And what's best — according to many pundits — for the Cup, from the standpoint of attracting more teams, more commercial sponsorship, more worldwide profile, and a sustainable existence, is to hold AC 34 in Europe.

Coutts also has two important things to consider. The first is that if the rumors are true, one or more European countries are offering big money to land the event, and let's face it, Coutts is not running a charity. The second is not pissing off his constituents — the professional sailors — who would be paying about 28%

more income tax if the event were in the U.S. than they would pay working under the 12% cap on income tax that was present in Valencia for the 32nd match. Don't kid yourself into thinking this isn't a significant concern for someone like Coutts — he would be giving up a pretty significant chunk of change himself if the rumors of his salary being in the mid seven-figure range are true.

Consider all of this in light of the fact that the nearly all-Kiwi team is based out of Valencia this year, and there are just too many indications that the event won't come here in '13 or '14. We think Newsom



COURTESY BMW ORACLE RACING

Can the red carpet overcome the green tape in the way of an America's Cup village on San Francisco Bay? Right now, it doesn't look promising.

understood this when he decided to no longer seek the CEQA exemption. Who knows, if BMW Oracle Racing successfully defends wherever the Cup lands, there just might be a chance we could get the next one.

SEPTEMBER SPECIAL

**FREE*
ENGINE TUNE-UP
WITH BOTTOM JOB
OR COMPARABLE
PROJECT**

**WE WORK SO
YOU CAN PLAY...
AND WE'LL
PROVE IT!**

**FULL
SERVICE
SHOP
WITH
DOCK
ACCESS**



MOBILE SERVICE



**WE BRING THE BOAT YARD
TO YOU!**

**BAY AREA
BOAT WORKS**

25 THIRD STREET
SAN RAFAEL
(415) 454-BOAT (2628)
INFO@BAYAREABOATWORKS.COM

www.BayAreaBoatWorks.com



**Adjust idle, compression test, spark plugs and more based on engine. Call for details.*

With a special report this month on **Three Elegant Ladies** who ply Bay water with grace and style, plus miscellaneous **Charter Notes**.

Tall Masts on the Bay: A Tale of Three Schooners

In an era when typical consumers seem to crave anything and everything that's ultra-modern, synthetic and built in China, it's refreshing to know that hundreds of Bay Area sailors still revere old-time nautical traditions. The annual Master Mariner's regatta, for example, attracts dozens of lovingly cared-for vintage woodies to their annual spring-time contest, and last month's Great San Francisco Schooner Race brought out close to 20 splendid S.F. Bay-based schooners, three of which are licensed to charter.

They are: the 115-ft (LOA) *Eros*, the 85-ft (LOA) *Seaward*, and the 78-ft (LOA) *Freda B*. Each one is focused on different niches within the charter market, which we'll tell you about here.

If you know anything about the pedigree of the spectacular schooner *Eros*, you're probably wondering how this European-built hull can legally charter in U.S. waters. After all, the 90-year-old Jones Act still restricts foreign-built hulls from chartering here, supposedly in order to protect American ship-building. Yeah, we know, "What American ship-building?"

Apparently that's the question that renowned nautical preservationist Elizabeth Meyer asked during her bid to win

Although there are modern upgrades elsewhere, the main salon aboard 'Eros' is true to its 1939 styling.

an exemption so that her famous 1934 J-Class sloop *Endeavour* could legally charter in U.S. waters. She eventually did win the battle, which elevated her beloved 130-footer to a special legal status. The way we understand it, this created a legal loophole that only vintage vessels of a certain tonnage can sail through. *Eros*, which is 103 feet on deck, meets the strict criteria for the exemption too. In fact, just last month her owners, Bill and Grace Bodle, received their Coast Guard certification, making her the largest sailing yacht available for charter on the Bay.

As we explained in our October 2009 feature on this exquisite Marconi-rigged schooner, she was built in England in 1939 for the daughter and son-in-law of a British Lord, and had a remarkably colorful history before arriving in the Bay in the late 1980s. Not only had she been commandeered by the Royal Navy before her owners took a single cruise aboard her — she participated in the famous evacuation at Dunkirk, in addition to patrolling the English coast — but she served for many years as a floating playground for Greek shipping tycoon Stavros Niarchos — renowned as the world's first billionaire.

Bill and Grace ran across *Eros* often in the Med during the Niarchos years, as they ran charters for years aboard their previous schooners, *Nordlys*, *Grace* and *Panda*, splitting seasons between the Caribbean and the Med.

The story of how they came to own *Eros*, however, is a long one. The capsule version is that a German businessman bought her in 1991 and commissioned Alameda's Stone Boat Yard — which was then owned by Bill and Grace — to refit her from stem to stern. The mind-numbing process included removing her entire interior and each of her 3-inch-thick Burma teak planks,



so her steel skeleton could be refurbished.

Thirty men worked on her day-in and day-out for about a year, before the German ran out of money. He settled the delinquent yard bill by signing over the stripped-down hull to Bill and Grace. When you see *Eros* today, that seems like a sweet deal. But, in fact, it took another 18 years, countless hours of labor, and buckets full of cash before she was finally finished and able to sail again last summer.

As you can imagine, a daysail, overnight charter or week-long cruise aboard *Eros* won't come cheaply. But if you can afford the price of admission, we can't think of a more worthwhile reason to splurge. This vintage thoroughbred's restoration is truly museum-quality.

Today *Eros* can comfortably accommodate up to eight guests in four double cabins, and will be equipped while on charter with small boats for sailing, paddling, water skiing or snorkeling.



OF CHARTERING



TOM BRICHTA

It took 18 years to fully restore the classic 1939 schooner 'Eros'. She's a nautical work of art, seen here blasting across the Bay.

Her elegant main salon has been preserved exactly as it was when launched, apart from the addition of a piano and a plasma TV that disappears from view when not in use.

The galley, however, is state-of-the-art, as Grace — who was trained as a Cordon Bleu chef in France — loves to whip up all sorts of exotic cuisine. The schooner will carry a crew of six while on charter.

Bill and Grace have successfully chartered their schooners all over the world. As Grace explains, "Our guests have included captains of industry, movie directors, yacht designers, avid sailors, the rich and famous, and the not-so-rich and not-so-famous.

"The common thread among them has been a love of sailing coupled with a desire to relax in a unique and private setting, away from the pressures and

stresses of normal life."

For the remainder of the summer, she'll be available for short charters on San Francisco Bay. Then in late October she'll sail out the Gate bound for Panama.

There, she'll be available for charters for several months in the Las Perlas Islands and the San Blas Islands, before repositioning to the Eastern Caribbean. There, Bill and Grace plan to cruise and charter within the 500-mile island chain between the Virgin Islands and Grenada,

and we wouldn't be surprised to see *Eros* participate in any of the Caribbean's classic yacht regattas — where museum-quality vintage yachts are the norm.

Oh, and we should mention also that if money is no object, the crew can arrange to have the ultimate charter toy on board: one of Graham Hawkes' deep flight submersibles and a professional instructor! For more info call (510) 439-8830, or see www.schooneros.com.

Although *Eros* is a hard act to follow, the staysail schooner *Seaward* also has plenty to crow about. Since her arrival in the Bay five years ago, this 85-ft steel schooner has served as the flagship and floating classroom for the Sausalito-based nonprofit Call of the Sea, which is primarily dedicated to youth sailing programs. And in doing so she's sparked curiosity about a broad range of disciplines in the minds of *thousands* of young scholars.

Co-founder and primary skipper Alan Olson says, "Our 3-hour program, Bay Explorations, gives students a rich, hands-on experience aboard a traditional sailing vessel, as they learn about Bay and California coastal history, practice navigation and seamanship, and explore the unique environment of the San Francisco Bay."

The program's curriculum is designed to mesh with fourth- and fifth-grade California state standards in social studies and science, but can be adapted to other grade levels also. "With a large sailing vessel as a teaching platform," Alan ex-

During Seaward's Mexico cruises, activities strike a balance between education, exertion and simply catching up on relaxation.



WOODY SKORIAK

WORLD

plains, "students receive an invigorating outdoor program that inspires inquiry and understanding."

It's been an awfully long time since we were in the fourth or fifth grade, but these programs sound more engaging and fun than any field trip we ever took. In addition to learning about the Bay's marine ecology and early California history, kids get to raise sails, take a turn at the helm and do a bit of hands-on traditional navigation, using charts, a compass and a good old-fashioned taffrail log.

But such programs are only a portion of what *Seaward* has to offer. Built in '88 for both comfortable inshore chartering and challenging offshore passage-making, she carries the highest possible US Coast Guard stability rating for exposed waters, and has a smooth and comfortable motion.

In addition to her youth education programs, she's also available for a variety of private group charters with up to 40 passengers, as well as Saturday morning Family Adventure sails (on selected weekends), sunset sails, and



WOODY SKORIAK

Whether young and old, everyone gets a chance to pitch in and learn the ropes during *'Seaward's* Mexico cruises.

educator outreach sails where teachers get an advanced look at the elements of the schooner's educational programs.

Regular readers probably know all that, but they may not know that she's also offering some very special opportunities this winter outside the Bay, as she's heading for the sunny latitudes of Mexico. From early January through late March *Seaward* will offer a series of cruises in and around the Sea of Cortez, in addition to the southbound and northbound legs at either end of the schedule that are great for those who are eager to test their mettle or earn sea time toward a Coast Guard captain's license. If time allows, stops on the transit legs may include Cedros Island, Magdalena Bay, and possibly a day-long visit to the protected whale breeding grounds of San Ignacio Lagoon.

As Alan points out, these 6- to 15-day programs are ideal for folks who can't make the timing of the Baja Ha-Ha rally or can't afford the time and money to go cruising on their own boat.

Within the schedule there's also a Sea Scout leg, and a Rotary leg focused on bringing school books, supplies and clothing to the remote fishing villages in

Real People. Real Sailing. Real Fun.



Sail Cats | Power Cats
Monohulls | Trawlers
Bareboat | Skippered

Real Choices.

Choose CYOA and become part of the family. We've been providing beautifully maintained yachts, personal service and sensible prices to sailors since 1980.



1-800-944-2962
info@cyoacharters.com
www.cyoacharters.com
St. Thomas USVI 00802

CYOA
YACHT CHARTERS

BETA MARINE WEST

Beta Marine Diesel Engines and Generators

With Dealers in:

- Los Angeles
- San Pedro
- Wilmington
- Santa Barbara
- Newport Beach
- Morro Bay
- Ventura
- San Diego
- Hawaii

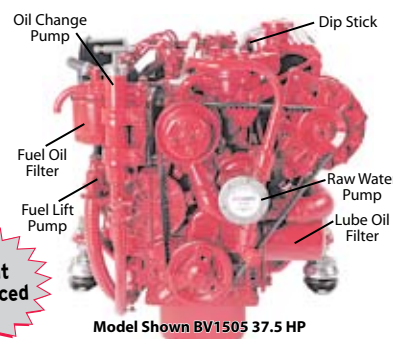

The engine that can be serviced easily!

Model Shown BV1505 37.5 HP

HIRSCHFELD YACHT LLC
Marine Repair and Installation Specialists
Full Service Shop with Dockside Access

Electrical	Engines	Outdrives
Generators	Inboard/Outboards	Propellers
Controls	Installation	Transmissions

www.betamarinewest.com
415-332-3507
39 Liberty Ship Way, Sausalito 94965

OF CHARTERING

the Sea of Cortez.

"*Seaward's* goal this year will be to expand the Rotary-sponsored mission," explains supporter John Skoriak, "while making sure that there is also plenty of time for fun, exploring, adventure and experiencing Mexican culture. This year *Seaward* will also host local Mexican youth groups on board for several-day or week-long legs.

"As in previous years, the passengers will typically be a mix of adults, both male and female, couples and singles, and perhaps even a young trainee crew member doing a semester at sea to learn the ropes.

"A typical winter crew may include passengers who have never sailed before, as well as experienced hands from local sailing schools and yacht clubs.

"Under the watchful eyes of *Seaward's* experienced captains and professional crew, passengers assist in every phase of operating the boat, from hoisting sails to steering, from navigation to anchoring, from cooking to cleaning. It's all part of the adventure!

"Sailors who have some experience, but have never done an ocean passage, often sign up for the ocean legs, Los Angeles to Cabo, or the trip back to San Francisco."

Seaward's home berth is in Sausalito at the Bay Model Visitors Center. For more info about all of her programs call (800) 401-7835 or visit the website: www.callofthesea.org.

The latest addition to the Bay's charter fleet is the 78-ft gaff schooner *Freda B*, which arrived here in June. Built of steel in '92 in Florida, this black-hulled beauty was designed specifically for chartering.



WOODY SKORIAK

Taking a turn at the helm of a splendid schooner like 'Seaward' while roaring along in Mexico's sunny latitudes. What could be better?

Although buying her in a down economy may seem like a bit of a gamble, her new owners, Paul Dines and Marina O'Neil of S.F. Bay Adventures, know from experience that there's a substantial



Tortola BVI
Belize
The Grenadines

**UNIQUELY
TMM**

Most charter companies offer blue water & palm trees, but it takes the personalized care of people like Marisa to make your vacation a success.

Like Marisa, everyone at TMM is committed to your complete satisfaction. Our specialized three-location operation offers large company quality with small company service. A combination that is uniquely TMM.



TMM
Yacht Charters
Since 1979

catamarans • monohulls
motor yachts
ownership programs



Marisa
TMM Belize

"We had a true, worry-free 14 days of sailing. We got everything we asked for and then some!"
A satisfied BVI Yacht Charters Guest





BVI YACHT CHARTERS

Call: +1 888 615 4006
Or: +1 284 494 4289

BVI Yacht Charters is the first port of call for all yacht charters in the BVI. Whether you are looking for Bareboat or Crewed yachts, a Catamaran or a Monohull, a week or just a few days, our professional team is on hand to make it work, your way.

BVI YACHT CHARTERS
www.bviyc.com
charters@bviyc.com

WORLD

demand in the Bay Area for traditionally rigged vessels. And apparently their hunch is already paying off. They had their first paid charter aboard her the day after receiving their official Coast Guard multi-passenger certification in mid-July (for up to 46 guests).

For years, Paul and Marina have been booking charters of all types on other people's boats, as well as on their own 32-ft Grand Banks trawler *Simba*, which used to belong to Paul's sailing mentor, the late Charlie Merrill. They'll continue to do so, but they really wanted to be able to offer a traditional sailing craft whose schedule they completely controlled.

Marina explains, "Paul and I had been looking all over for a larger schooner, but everything we saw on the market was wooden, and we really wanted steel. In January, we finally heard about this one, and she seemed perfect for our needs."

Getting this sleek gaffer to the Bay was a story in itself. When Paul and Marina took the plunge a few months ago, the Atlantic hurricane season was fast approaching. Paul did some work on her in Florida, then shipped her from



WOODY SKORIAK

The new girl on the Sausalito waterfront is a fine addition to that nautical town's legacy of traditional sailing craft.

Fort Lauderdale to Ensenada, Mexico. From there, he and his crew sailed her to Sausalito in only three and a half days.

After arriving at her new homeport, she was soon re-named *Freda B*, in honor of O'Neil's grandmother, who was raised in Mill Valley and worked on liberty ships in Sausalito during WWII.

One of the good things about the 'new girl in town' is that you don't need to book the whole boat to enjoy a sail aboard her. She's slated to run 13 scheduled sails per month, which are individually ticketed. These include Friday evening sunset sails, an evening sail on every full moon, and weekend sails that focus on natural history and wildlife — from 9 a.m. to noon every Saturday and Sunday. Naturalist Trish Mirabella comes along on these to enhance the passengers' awareness and understanding of the Bay's natural ecosystems. "One of the great things about Trish," says Marina, "is that she's really enthusiastic, and she speaks both 'kid' and 'adult', if you know what I mean." We do. It's not every tour guide who can easily relate to kids and engage them in science.

In a similar vein, Paul is in the process of putting together special programs for

COAST MARINE

& INDUSTRIAL SUPPLY INC.
398 Jefferson St. San Francisco - On the Wharf.

Call **Bruce Becker:** (415) 673-1923
800-433-8050
Fax (415) 673-1927



LIFE RAFT
Sales & Service



U.S.C.G. Approved Testing Facility

- ★ U.S.C.G. life raft facility for Solas commercial yacht and fisherman rafts
- ★ COMAR DEBARKATION LADDERS
- ★ COMAR PILOT LADDERS
- ★ COMAR WORK LADDERS
- ★ All U.S.C.G. approved



"World's longest tested ladder 320ft."

Major Distributor for:









IN SAN DIEGO CALL OCEANS WEST 619 544-1900



OYSTER POINT

Marina/Park



A full service marina located in South San Francisco with berthing and guest dockage available

For information and pricing call

(650) 952-0808

www.smharbor.com/oysterpoint

OF CHARTERING

the Point Reyes Bird Observatory. "There are all sorts of special niche markets that can be tapped into. And this boat is great for special sails with a particular theme."

In the future, overnight trips, possibly outside the Gate, may also be offered, as *Freda B* has eight bunks. For the time being, though, she'll stick to her scheduled sails, while also offering a variety of customized group charters: nautical weddings, corporate teambuilding, the spreading of ashes, regatta spectating, Angel Island picnics, student sailing programs, you name it.

While many Bay boats make similar offerings, we don't know of any others that enthusiastically attend the annual NorCal Pirate Festival in Vallejo each August. Marina says she can hardly wait to sail up the river next year aboard *Freda B*, with a boat-load of fully costumed swashbucklers lining the bulwarks. Sounds like fun to us.

"We're over the moon about *Freda B*," says Marina. "How many times in life do you really get to live your dreams?" Point

well taken. We wish them the best of luck. For more info call (415) 331-0444, or see: www.sfbayadventures.com.

Generations ago schooners and square-riggers were the dominant breed on the Bay. But these days, of course, their numbers are few — all the more reason to spend some time aboard any or all of these three lovely ladies.

— andy

Charter Notes

While we're on the subject of newly certified charter boats in the Bay, we're happy to report that Captain Kirk Miller recently obtained a multi-passenger Cer-

Partners Paul and Marina (at the wheel) shared a happy moment with their crew shortly after 'Freda B' arrived on the Bay.

tificate of Inspection (COI) for his sweet **Santa Cruz 50 Bay Wolf**. Although she can now legally charter with **25 passengers**, Kirk says, "We are focusing on groups of up to 20 passengers with 12-15 being the ideal number." Either



WOODY SKORIAK

Sail Mexico Aboard the Schooner Seaward ~ Winter 2011



Answer the 'Call of the Sea'
Adventure Voyages to
Mexico's Sea of Cortez

Contact us now! Limited Availability!

Be part of the adventure. This is a hands-on opportunity for all levels of sailors to enjoy the pristine beauty of Baja and camaraderie with your shipmates.

Log Angeles to Cabo San Lucas	January 7-19
La Paz to La Paz	January 25-30
La Paz to Cabo San Lucas	February 28-March 5
Cabo San Lucas to Los Angeles	March 8-22
Los Angeles to San Francisco	March 24-29

These trips share the educational spirit of Call of the Sea's mission and help support our Youth Programs.

Seaward is an 82-ft USCG-inspected vessel owned by Call of the Sea, a non-profit educational organization.

www.CalloftheSea.org • (415) 331-3214 • info@callofthesea.org

HASTY HEART

Custom SF Bay Charters

Special Rates for Charter Captains



You imagine it — we'll plan it.

61-ft Swan

(415) 690-7245 or www.sailhastyheart.com

WORLD OF CHARTERING

way, that's a big step up from his previous 'six-pack' (as in six passenger) rating.

"We have been having a great time with the boat," says Kirk, "taking groups out under the Gate and showing them some real fast sailing. She's a total joy to sail: fast, responsive, and she has a long racing history that includes a strong showing in the in the 1998 Pacific Cup."

Kirk encourages active participation, making the pitch that chartering with him is a "great opportunity to sail on a legendary racing yacht without the hassle or expense of owning the boat."

He offers a wide range of group charter options, from weddings to teambuilding and everything in between. But his boat's racing pedigree is what attracts most customers. After all, as her designer, Bill Lee, famously said, "Fast is fun!"

One thing about Kirk's operation that's well worth pointing out is that



If you agree that fast is fun, consider spending a day with Captain Kirk aboard the record-setting SC 50 'Bay Wolf'.

he **donates 10% of his gross** (not net) revenues to nonprofits including Big Brothers Big Sisters, Guide Dogs for the Blind, the Spaulding Wooden Boat

Center, Operation Smile, and others. Guests can pick the charity of their choice. We tip our hats to him for that and would encourage other operations to follow suit if they can.

For more info on *Bay Wolf's* charter offerings, see www.sfbaysail.com.

We'd also like to say a heartfelt *happy birthday* to Jay Gardner and the crew at **Adventure Cat Sailing Charters**, who are celebrating their **19th year in business** this month.

As a **special promotion** to *Latitude* readers they'll take \$19 off every Bay Cruise or Sunset Cruise on September 19, which brings the cost down close to what it was when they started

nearly two decades ago — we're talking about a Bay Cruise for only \$11.00 or \$26.00 for a Sunset Cruise. Sounds like a party that's well worth attending. Happy birthday, guys!

To sign up, call (800) 498-4228 or visit www.adventurecat.com.

SAUSALITO



LIST MARINE INC.

- Full service engine shop
- We service all makes
- Dockside facilities
- Mobile service trucks

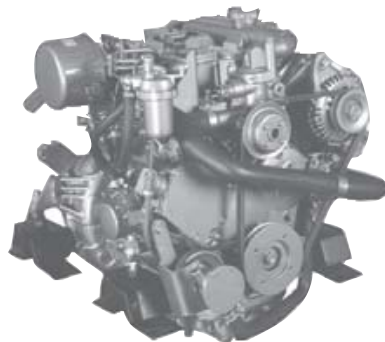

P.O. BOX 2008 / 69 LIBERTY SHIP WAY • SAUSALITO, CA 94966
Adjacent to Schoonmaker Pt. Marina

415•332•5478

www.listmarine.com

Have Bundle - Will Travel

Planning to travel to some far-flung destination?

If you're planning to fly out to meet friends in Mexico, the Caribbean or the South Pacific, why not stop by the *Latitude 38* office before you leave and pick up a bundle of magazines to share with cruisers?

We promise you'll be a hero — and you will probably earn a few beers for your efforts.

The *Latitude 38* office is open 9-5 weekdays and is located at 15 Locust Ave., Mill Valley, CA 94941 • Call (415) 383-8200 for directions.



What's a summer day's cruise in the Pacific Northwest?

How about 17 hours of daylight!!!

Bellhaven Yacht Sales & Charters

- San Juans
- Gulf Islands
- Desolation Sound

**Power & Sail Charters
ASA Sailing &
Power School**

www.bellhaven.net
bellhaven@bellhaven.net

877-310-9471

BELLINGHAM, WA

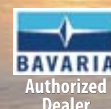



Lowrie Yacht Harbor INC.

*In central Marin, convenient to Delta & Golden Gate
Family owned & operated since 1948*

- **\$6.50** per foot – Best Rates this side of the Bay
- 25' - 65' Berths Available
- Surge and Wind Protected – Out of the Fog
- Convenient Location – Warm and Sunny
- Whole Foods & Trader Joe's Nearby
- Office Space Available

(415) 454-7595

40 Pt. San Pedro Rd., San Rafael, CA 94901
New Harbor Office Hours: M-F 9:30-4:30

AQUAMARINE

Watermakers Since 1987

SPARKLING FRESH WATER, POWER, AND REFRIGERATION FROM THE SEVEN SEAS

110 VOLT / BELT DRIVE



AQUAMARINE



MODULAR KIT

HYDRAULIC



MYTGEN 150



12 VOLT DC



UPGRADE MOUNT



316 S/S REMOTE PANEL

AquaGen combines the quality, simplicity & reliability of AquaMarine, Inc. watermakers with the durability of the Kubota 150 amp 12V diesel generators. This compact low fuel consuming AquaGen is a powerhouse, capable of producing up to 150 amps, and 8 up to 62 GPH of fresh potable water from any water source. Make fresh water, refrigeration, and also charge your batteries all at the same time! A hydraulic pump may also be added to run your dive compressure, windless, bow thruster, or emergency bilge pump. Ideal for longterm cruisers or weekend wanderers. We custom engineer our systems to fit any size vessel or cabin site. Electric, Hydraulic, or Belt Driven Modular Kits are also available. Visit our Website for more information.

QUALITY AT AFFORDABLE PRICES.

LIFETIME WARRANTY ON PUMP HEAD AND PRESSURE VESSELS.

AquaMarine, Inc., 58 Fawn Lane (P.O. Box 55) Deer Harbor, WA 98243 USA
(800)or(360) 376-3091 Fax (360) 376-3243

www.aquamarineinc.net

THE HEROIC TAILS OF ADVENTURE CAT!

PART III



"I REMEMBER BACK WHEN I WAS JUST A LITTLE KITTEN AND MY OWNERS DREAMED UP THE IDEA TO BUILD A LARGE CATAMARAN. THEY LOVED SAILING SO MUCH AND WANTED OTHER PEOPLE TO EXPERIENCE THE BEAUTIFUL SAN FRANCISCO BAY."



"HERE WE ARE 19 YEARS LATER USING NATURAL WIND POWER TO TAKE PASSENGERS OUT FOR DAILY CRUISES. UNLIKE FUEL, THE COST OF WIND HAS STAYED REALLY AFFORDABLE OVER THE YEARS...FREE!"

HELP US CELEBRATE OUR 19TH BIRTHDAY!

WE'RE OFFERING \$19 OFF ALL
ADULT TICKETS ON SEPTEMBER 19.
TO SIGN UP, CALL (800) 498-4228
AND MENTION THIS AD.

SORRY, NO WEB-BASED RESERVATIONS
ON THIS SPECIAL DEAL.

CHANGES

With reports this month from **No Name** on cruising Mexico for eight months aboard a 30-footer; from **Nanu** on emergency surgery south of the border; from **Azure II** on cruising the Med with a 5th grader and a 7th grader; from **Digital** on medical problems before and while cruising; a cruiser's **Mini-Guide to Santa Barbara**; and **Cruise Notes**.

No Name — Catalina 30 Bob Bahlman and Margie Hewes Eight Months On A Catalina 30 (Sausalito / Lake Tahoe)

Bob and Margie's original plan was to sell their home in Tahoe, then buy a boat bigger than their Catalina 30 in order to "go anywhere for as long as we wanted."

But when the housing market went in the dumps, they decided to take their home off the market, rent it as a vacation rental, and cruise Mexico in the boat they already had.

"We're so glad we ended up doing it the way we did," says Bob, "because it gave us a chance to find out if we really liked

cruising before pouring a lot of money into a much bigger boat. We discovered that we really do like cruising, and the next time we go out, we want to do it for an indefinite period of time. But the Catalina was a great boat for an eight-month trial in Mexico."

"No Name had everything we needed and was really great," agrees Margie, "but it was a little bit like camping. So now that we know we love cruising and want to go out for a much longer period of time, our next boat will have many more creature comforts. She will also be quite a bit bigger, as we really got nailed going into Turtle Bay on the way back. It was like white-water rafting."

One of the benefits of a simple boat is that there is much less to go wrong.

With Margie being a personal trainer and spin instructor, there was no need for 'No Name' to be outfitted with a windlass. She was it!

"The only mechanical problem we had in eight months of cruising was with an electrical part of the engine ignition. But once I brought the part down from the States and replaced the bad one, it was the end of our problems. On the other hand, we met a lot of other cruisers on bigger and more complicated boats who got bogged down with engine, transmission and other problems."

The couple started their Mexico adventure by doing the '09 Ha-Ha. Unlike most one-season cruisers, they travelled all the way down the coast of mainland Mexico to Huatulco, which is about 350 miles southeast of Acapulco. "It wasn't until we got down there that we found the really clear blue water and white sand beaches that we'd been dreaming about," says Margie. "On the way back north, of course, we discovered that the Sea of Cortez has beautiful blue water and white sand beaches, too."

"Our impetus for heading that far south was a conversation with a woman who recommended we visit Puerto Escondido," remembers Bob. "But it was Huatulco that we really liked. We spent 15 days in a marina and really enjoyed ourselves. One of the best parts was that we met lots of cruisers who were really 'out there'. Because if you're passing through Huatulco, you're not a one-season cruiser, but either someone who is returning from a long cruise or just taking off on one."

Despite going with just a 30-footer, the couple brought along some toys, including kite boards, a gas-powered hookah, dive equipment and much more. The one thing they wished they'd brought, but didn't, were bikes. Both are very much into physical fitness, and thought the bikes would have given them much more cardio, in addition to more mobility on land.

A diver for more than 20 years, Margie was knocked out by the El Bajo sea mound that comes to within about 60 feet of the surface in the Sea of Cortez. "It had the most sea life we saw anywhere on our trip. Among other things, there were lots of big green moray eels, the kind you only find in deeper water. We really recommend El Bajo."

While having a simple

LATITUDE/RICHARD



Finally, clear blue water and white sand beaches in Mexico.



boat has much going for it, it also means there will be some inconveniences. For example, there is not a lot of room on a 30-footer to store a dinghy on deck. So they either towed it behind the boat or had to go to all the trouble of breaking it down and storing it in the quarter berth each time they made a significant passage. And then they had to put it all back together and launch it when they wanted to use it again. But they didn't seem that put out by only having an eight-foot dinghy with a 2-hp outboard — augmented by a two-person inflatable kayak.

No Name was also one of the few full-time cruising boats without a windlass. "This is my windlass," laughed Bob, pointing to Margie. "I was a personal trainer at the Mill Valley Health Club & Spa," she said, "so damn right I pulled the anchor up hand over hand."

Having learned from their eight months of cruising, Bob and Margie currently plan to sit on their house and wait for the housing market to recover

LATITUDE/NICK



IN LATITUDES



LATITUDE/NICK

"The incision was this long," says Rachael, indicating the length of the cut with her hands. Her hands also describe how tall the stack of hundreds probably would have had to be to pay for the same surgery in the United States. Meanwhile, Eric feigns how he felt after surgery.

before selling it and downsizing to a condo. "When we move up to a bigger boat, we want to pay cash for her," Bob explains.

— latitude 08/05/10

Nanu — Ericson 29 Rachael Nemcsok / Eric Sorensen Surgery South Of the Border (Half Moon Bay)

We've read many reports in *Latitude* about how often cruising plans change. Ours have changed more times than Eric and I have fingers and toes. We've also read plenty of stories in *Latitude* about how good and economical medical care can be in Mexico. Little did we know that we would experience it firsthand.

Eric and I met in Puerto Vallarta in '08. He'd already singlehanded from Half Moon Bay to southern Mexico, and had sailed back up to Puerto Vallarta to visit his parents. I'm a mining engineer, and

I was in Vallarta on a work break from my job at a silver mine in central Mexico. Eric swept me off my feet by, among other things, teaching me how to sail. So I quit my job and moved aboard with him. You can imagine how thrilled my family back in Canada was.

When we cruised the Sea of Cortez that summer, this girl from a small town in Ontario found just about everything from the cactus to the goofy booby birds to be as interesting as anything I'd ever seen before. Although the crystal clear waters lured us to stay longer, by August the sweltering heat of the Sea finally became more than we could bear. After putting *Nanu* on the hard at Marina Seca, Eric returned to work in California and I to work in Canada.

Eric returned to *Nanu* after four months, then did the Bash back to California.

I was relieved when he called to tell me he'd finally gotten the boat tied up back in her berth in Half Moon Bay. It was a very short-lived relief, for after being home for only six hours, Eric lost control of his bike going down a steep switchback road, and slammed head-first into a parked car at an estimated 50 mph. He suffered severe brain hemorrhaging, fractured both of his eye sockets, collapsed both lungs, had a compound fracture in his right tibia, ruptured his spleen, and had other injuries.

Despite the horrific accident, Eric was back in full action by October. I quit my job again, and joined him in California to help prepare *Nanu* for a cruise to Ecuador. Having looked into it, Eric decided that Ecuador — with its temperate climate, lack of lightning, and low cost — would be a good place to leave the boat for a summer before we would head across the South Pacific.

We crossed the border into Mexico in December of '09, and welcomed in the new year at La Cruz. We love Mexico for the beautiful scenery and wonderful people! We took our time heading south, hitting lesser known anchorages and staying longer than planned in some places to mingle with long-lost friends or have dinner with new ones. We caught excellent surf at Quimixto, rowed up the jungle river at Tenancatita, and knocked down coconuts for eating at Carrizol — to name just a few of the fun things we did. We were the happiest couple that

Whenever Rachael had to get on the radio to call for help, other cruisers would respond — even at 3 a.m.

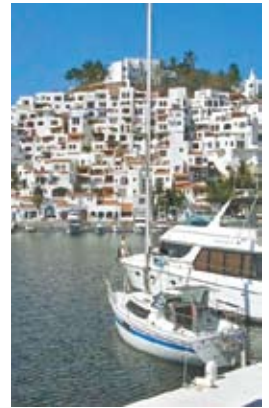

LATITUDE/RICHARD

Eric was first taken to the doctor at the Las Hadas Resort.



LATITUDE/NICK

CHANGES

the world had ever seen.

But on January 22, while anchored in Carrizol Cove, which is about four miles northwest of Manzanillo, things started to go bad. After a wonderful dinner with friends Linda and Mike aboard their boat *Tranquilo*, Eric began to complain

of a sore stomach. Neither of us thought much about it, but that night he began to vomit violently. His condition worsened the next day, so that afternoon Mike and Linda, plus Kevin from *Tashee*, convinced Eric to see a doctor.

Unfortunately for Eric, Gatorade doesn't cure ilius.

Eric and I were taken aboard *Tranquilo* and rushed to the Las Hadas Resort, where Mike and Linda had arranged to have the doctor waiting. After poking and prodding at Eric's now swollen and painful stomach, the doctor diagnosed him as having an intestinal infection caused by something he'd eaten. After giving Eric an injection of what we believe to be a painkiller and an antibiotic, he sent us on our way with some Gatorade. He said Eric needed to return the next day for one more shot. The visit at the luxury resort hotel cost us \$120.

Eric was still having stomach problems when he visited the doctor the next day, but the doctor reassured us that Eric would be fine, and that he could eat again.

That night, Eric only managed to down a little pea soup before he had to lie down because of the pain. Even the emergency pain medication couldn't mask his severe discomfort. By 3 a.m. I was desperate for help. I had no luck

With Eric healthy once again, he and Rachael enjoyed a sundowner in San Diego after the Bash and before continuing to Half Moon Bay.

hailing *Tranquilo* on the VHF, but Kasey on *Isis* and Kevin on *Tashee* responded. Within 15 minutes, Berke, Kasey's husband, had dinghied over and was taking us to shore. Questioning the night clerks at Las Hadas, we learned that we had two options for healthcare in Manzanillo. The public hospital, which the clerks said was inexpensive but didn't offer the best care, or the Echauri Medical Clinic. Echauri was recommended by all the clerks, although they said it was more expensive. Burke, Eric and I piled into a cab and headed there at 3:30 a.m..

Eric was immediately taken to a doctor's office, and after a knowledgeable, English-speaking female doctor felt around his abdomen, she ordered x-rays. When the x-rays were returned, the doctor explained that Eric probably had a blockage of his intestines — but she wanted to speak with a specialist. Despite the hour, the specialist was called immediately, and Eric was put on an IV.

While waiting for the specialist to arrive, I was asked if we were willing to pay for the "recommended procedures" to ensure that Eric got the best healthcare they could offer. "Of course," I said.

When Dr. Rivera arrived, he used modern ultrasound equipment to outline the area where Eric's intestines were blocked, and followed his digestive track to make sure there were no other complications. After unsuccessfully trying to clear Eric's intestines without surgery, the Dr. Rivera said Eric had to go under the knife. If not, his intestines would rupture. However, they wouldn't operate without a downpayment of \$776, payable in cash or by Visa.

Surgery revealed that Eric had an ilius, which is an intestinal blockage caused by scar tissue. When the doctors in the U.S. removed Eric's spleen following the bike accident, his intestines sustained scars, which eventually healed over completely. But closing off that part of his intestine led to his inability to

digest food as before, and eventually resulted in his swollen stomach and lots of pain.

Eric had a three-hour surgery that morning. Dr. Rivera assured me that the surgery had gone exceptionally well, and that all Eric needed was rest.

The doctor escorted me to Eric's hospital room — a clean, private room with a private shower and toilet. There was a small bed for



a visitor, air-conditioning, and cable TV. Despite all of the comforts, what Eric most wanted was for me to read him the articles from *Latitude* that we'd saved on his laptop. Over the course of about three days, I read him the December and January *Latitudes* over and over again, explaining in depth what the photos looked like.

In the four days that Eric and I spent at the hospital, we got to know the nurses and doctors. Everyone spoke a little bit of English, and most doctors were nearly fluent. Everyone went out of their way to make Eric and me as comfortable as possible. Eric's condition stabilized surprisingly fast, and by the fourth day his bowels were doing what they should be doing. The surgeon bade us farewell, and reminded us to return in five days to remove the stitches.

When we walked out of the hospital, Eric had a new 15-inch incision down the center of his abdomen, with 18 stitches and a smaller drainage hole on his left

GARY GATOR



LATITUDE/NICK



IN LATITUDES



BOTH PHOTOS COURTESY AZURE II

Spread; A little overdressed for Ibiza, Jane gets a free minute while, inset, the Pimentel males scale the peak above Dragonera.

side. The total bill for our stay and the operation was \$2,066, which is probably a little less — LOL — than it would have been in the States.

Five days later, Eric called the surgeon at his home and made an appointment to have the stitches removed. Walking into the clinic that night, Eric was greeted like a rock star! The nurses and doctors jumped to their feet and rushed over to shake his hand, then hurried to find Dr. Rivera. Eric's stitches were removed within 10 minutes of our arrival. After asking him how much we owed the hospital for removing the stitches, Dr. Rivera chuckled, shook our hands, and gave me a hug. "Nada," he said. He ushered us out of the door after reminding Eric not to do any lifting or heavy exercise.

Eric's recovery was a mental and physical learning experience for both of us. For example, we got to know each

other really well. And I soon became competent at lifting 6½-gallon water jugs from our Fatty Knees dinghy onto the deck of *Nanu*, something I hadn't been able to do before. There were fun parts, too. Other cruisers giggled when they saw me rowing Eric to shore, and unable to drink alcohol for a month, Eric took me out on a lot of ice cream dates.

The experience confirmed that the cruising community is full of the most wonderful people from around the globe. You all know who you are. And that cruisers can get wonderful and inexpensive medical care in Mexico.

— rachael 04/16/10

Azure II — Leopard 47 Cat The Pimentel Family Gibraltar to The Balearics (Alameda)

[The following are a series of reports from Rodney, Jane, and their 7th and 5th graders, RJ and Leo.]

We spent five days at Marina Bay Marina in Gibraltar, which is a great location because it's near the town center and airport. We said goodbye to friends Nani and Noelani after a great week, and walked them to the airport! Gibraltar is the only place I've been where a busy street crosses a runway. There are gates that go down when a plane is landing or taking off, but other than that, you just walk across the runway.



AZURE II

Everything must be dual purpose, so the kayak doubles as a diving platform.

Gibraltar is unusual because it's located in Spain, but has its alliances with Britain. The British took Gibraltar from Spain in 1704, and have held it ever since despite the fact that Spain has tried to take it back 14 times.

We wanted to see the 'Rock', so we all took the cable car to the top. The famous Barbary macaques — aka monkeys — roam freely at the peak, and don't hesitate to steal candy from a baby. From the top we were able to walk down and see Saint Michael's cave, the Great Siege Tunnels that were hand dug by the Brits in the 1700s, and the Moorish Castle. RJ and I were not satisfied with just taking the cable car to the top, so the next day we climbed to the top and then back down the back side. There are amazing views from the summit, as you can see Africa to the south and Spain to the north. — Rodney.

07/24/2010 — We left Gibraltar on Friday at noon, and spent the night anchored off the beach just inside the

Leo and RJ, resting in the hammock, are having Med cruising experiences that they'll likely be laughing about for the rest of their lives.



AZURE II

CHANGES

breakwater in Fuengirola, Spain. We arrived at 8 p.m., but there were still 90 minutes of sunlight left. Even though we are at latitude 36, the sun doesn't set until 9:30 p.m., so the beach was packed with swimmers until 10 p.m. The coast of this part of Spain is lined with high-rises, and the towns seem impersonal compared with the quaint villages of the Azores and Portugal. On the way here, we passed the Sierra Nevada Mountains and anchored in Playa San Francisco. Are we in Spain or California? — Rodney

07/31/2010 — We spent five nights in Puerto Almerimar in the south of Spain as we waited for the weather to change.

Our plan is to stop in Cartagena on our way to Alicante. In Almerimar, we had to Med-moor for the first time. This is where you tie

In Europe, old is better than new.

the bow or stern to a concrete wharf, and either anchor or grab a mooring line in the middle of the channel. Securing our cat in this fashion is very scary, as you can easily hit the concrete wharf in the process of getting settled. The other unusual thing about Med-mooring is that you need some way to get from the boat to the concrete pier. Many boats use an aluminum ramp or wooden plank to span the gap. In the spirit of everything on our cat needing to have a dual purpose, we use our kayak as a *passerelle*, which is the Med name for such a ramp.

The southern coast of Spain is very arid, and has sandy cliffs but no trees. The Spaniards figured out the best use for this dry sparse land was growing

Ibiza is the most x-rated island in the world. In fact, naked mud-bathing is pretty tame compared to what goes on in the nightclubs.

things in greenhouses. It's strange to see that most of the flat part of this coast is covered in white plastic. From the sea it almost looks like patches of snow running down to the water. There are over 300 days of sunshine here per year, so the coast is also being assaulted by large resorts. There aren't many safe anchorages along this coast, so we've had to stay in marinas. We're ready to get to the Balearics so we can anchor — and save some moola. — Rodney

08/03/2010 — We spent three nights in Cartagena until our friends Sanna and Ville from Finland joined us. Sanna was our *au pair* 10 years ago when Leo was born. It was wonderful to spend time together, and it sure didn't seem as if a decade had passed since we'd seen them last.

Cartagena is trying to transform itself from a military port to a tourist destination, so they are investing big bucks to highlight the historical sites. Since Cartagena has a natural harbor, the Romans had an extensive settlement here. We toured some of the Roman ruins, including an amphitheater. Visiting a town with history is *mucho* more interesting than visiting the manufactured cities along the coast.

The Spanish Navy still has a base in Cartagena. The perimeter of the marina is surrounded with warships, including even a submarine. We visited the Naval Museum, which had an impressive collection of antiques from when Spain ruled the world. Some of the most fascinating items were the maps of the world before the Spanish had sailed around South Africa. Spain, of course, was located as the center of the world in all the maps. — Rodney

08/12/2010 — Yesterday we had a dreamy 50-mile reach from Ibiza to Mallorca, as it blew 10 to 15 knots on the beam with settled seas. We're continuing to explore the main Balearic Islands, as they were our primary destination when we left the Caribbean. They are known to have cliff-lined anchorages, crystal clear water, and soft sandy beaches. They are also known to be very crowded in August, the holiday month in Europe. But we haven't found it to be any more crowded than any other popular summer destination.

There are three main island in the Balearics — Mallorca, Menorca and Ibiza



— and a few smaller ones. Each has a unique personality. We just spent a week on Formentera, one of the smaller islands, and Ibiza. Formentera turned out to be the naked island, with lots of natural mud baths and young people. We survived. Next we moved on to Ibiza, known around the world as the party island. We nonetheless managed to find some family-friendly spots with excellent snorkeling. RJ and Leo thought the water looked like a pool, and were thrilled to jump off the boat. The weather has been fantastic, although a little on the warm side. The beauty of being on the hook is that you just jump overboard to cool off.

As I write this, we're anchored at Port d'Andratx on the south coast of Mallorca, the biggest of the Balearic islands. Port d'Andratx is a well-sheltered, affluent area with gorgeous houses built into the cliffs. We'll probably spend a week to 10 days at Mallorca before heading on to Menorca, the last of the Balearics. The strange thing to us has been

AZURE II

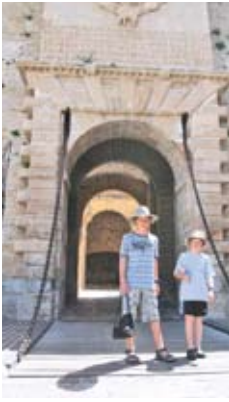

AZURE II



IN LATITUDES



PHOTOS COURTESY AZURE II

Spread; If you have a boat, you can escape the crowds of Mallorca at places like Dragonera. Inset; RJ takes another leap into the future.

the lack of American boats. We haven't seen one since leaving the Azores. There has also been a shortage of 'kid boats'. Rodney seems to have the boat dialed in, because he's actually been taking time off to read *Latitude*. So we must be cruising! — Jane

New Report — We're still in Mallorca, and we like it better than we imagined. We had heard it was crazy crowded, but with a boat, it's easy to get away from the masses by going to a remote anchorage. We'll probably be here another few days before going north to Menorca, the smallest of the major islands.

We started home-schooling a few weeks ago, but we had to ditch the traditional Calvert curriculum and put together what I hope is a more flexible and friendly program. I sourced a variety of 'best practices' for key subjects. We've started with math, Spanish and

typing, and have gently added writing and geography. History and science are a bit less structured, but also included. We still have some whining, but it feels amazingly better. — Jane

— the pimentels 08/15/10

Digital — Morgan Out-Island 41 John and Carol Stubbs Florida to California (Fort Lauderdale)

For all of Carol Stubbs' medical misfortunes in the last couple of years, she has a remarkably bright disposition. Her medical problems started just before she and her husband John departed Fort Lauderdale on a two-year cruise down the Western Caribbean, through the Panama Canal, and up the Pacific Coast to San Diego.

While still in Miami, she stumbled getting from a pier onto *Digital*. "I fell onto a stanchion, breaking a rib,

fracturing three others, and puncturing a lung," she says with a characteristic laugh.

John and Carol are big scuba divers, but her injuries kept Carol on the surface for quite a while. "When we got to Belize, I did a little test dive down to 80 feet, but it left me sick for three days. So only John got to dive at the famous Blue Hole in Belize."

"I dove down to 180 feet, and it was pretty interesting," says John, "particularly at about 80 feet where there were all kinds of sharks. Although the Blue Hole is perhaps the most famous dive site in Belize, I thought that many of the other reefs were actually much better. Long Cay, for example, is a really excellent dive."

"The good news," John continues, "is that there are still lots of fish in the Western Caribbean, so the fishing is really good. For example, if you know how to cook them, the barracuda are really delicious."

Barracuda? What about ciguatera poisoning?

"It's true, you can't eat barracuda caught off Florida because of the toxins they get from the reefs," John says, "but everybody eats them in Belize without a problem. And they are tasty."

John and Carol cruise with two big dogs. Hennesy is their pit bull and Marley is their collie mix. "Nobody tries to steal anything from our boat," laughs

'Why me?' wonders a just-awoken Carol of 'Digital'. If you had her share of physical misfortunes, you'd be asking the same thing.



John found the reef diving in Belize to be terrific.

COURTESY BELIZE TOURISM



LATITUDE/NICK

CHANGES

Carol.

Oddly enough, Hennesy loves to fish. "She'll watch the tip of the pole all day, and when it starts to twitch, she gets all excited," says John.

"When we get the fish aboard, Hennesy kills it by eating the head," says

Carol. "It doesn't matter how big or what kind of fish it is, she eats the head. Then she leaves the rest for us."

Carol's next medical problem arose while they were at anchor about 40 miles from Salina Cruz in southern Mexico. "She was in terrible pain," says

John, "so we set off the 911 on our Spot Messenger. By the way, I love that thing and highly recommend it

for all sailors. We later learned that the Americans at Spot couldn't get anybody in Mexico to come out and get Carol, so they called the American Embassy in Mexico, which called the Mexican Embassy, which called the Mexican Navy in Salina Cruz and demanded to know why they weren't helping us. So they headed our way."

Not knowing what was going on, after five hours John weighed anchor and headed for Salina Cruz. "I had to get my wife to help," he says. But just after he did, the Mexican Navy showed up in a drug-running type boat. Carol was taken onto that boat and transferred to another boat halfway to Salina Cruz, where she was given mild pain medication. Once they got to Salina Cruz, she was put in a hospital for a week.

"All the people were just wonderful," remembers Carol. "My problem was gallstones. But after my getting treated in the hospital for seven days, they didn't

Barracuda look nasty the world over. But the Stubbs report that they are safe to eat — in the western Caribbean — and taste delicious.



COURTESY BARNEY

charge us a cent!"

John had a much harder time getting to Salina Cruz. In order to get Carol taken off, he'd had to anchor *Digital* once again, this time in deep water with the wind gusting to 45 knots. He didn't mind being there, but the captain of the 150-ft navy vessel said he'd been ordered to tow *Digital* in. Attempts to ease the ship up to *Digital* to pass a line by hand failed, so eventually they shot a line to the Morgan Out-Island. With John unable to raise the anchor by himself, he eventually had to abandon it as well as all the line and rode. He wasn't very happy about it, but things were about to get worse.

Once the tow was underway, the captain of the navy ship insisted that John put the sails up. After being hit by a strong squall, *Digital* suffered a torn main and the jib sheet got fouled in the prop. Once inside the breakwater at Salina Cruz, control of *Digital* was passed on to a man in a small boat — who promptly let the Out-Island blow onto the rocks. Fortunately, there wasn't too much damage.

"What else can go wrong?" John thought to himself. "I had no sails, my engine didn't work, I had a crack in my hull, and I didn't know where my wife was." What else went wrong is that the commander of the port facility, a new guy, got weird.

"He interrogated me for two hours, asking me really stupid stuff like who my brother was. He wanted me to check into the country, but we'd already done that — and had proof. Finally I got really upset and said that I needed to find my wife. He kind of backed off. After the bomb and drug dogs got done sniffing my boat, the commander became nice and said, "You can go find your wife now." After that, he and everyone else was really friendly. Very, very friendly. We'd meet in all their offices, have lunch with them, that kind of stuff. They ended up being wonderful."

Once Carol recovered, the couple cruised up the coast without trouble — until they anchored off Los Arcos in Banderas Bay. "Carol suddenly started having seizures, something she'd never experienced before," says John. "She had 12 of them in one day, so we called for assistance over the VHF, but nobody heard us. So we went ashore and called an ambulance. Once the ambulance was on its way, I had to return to the boat because it had dragged there before and



because the dogs don't do well alone."

"It was really weird," says Carol, "because when the ambulance arrived, the woman paramedic tried to blame John for my seizures! She was crazy and kept making these ridiculous accusations. 'Fuck you!' I finally said, 'it has nothing to do with John.' Then I walked down to the water's edge to swim back to *Digital*. But as soon as I hit the water, I had a seizure. I recovered, but then had another one. Before long I had sand coming out of my mouth and everything. Two great young Mexican guys, who had seen some of my previous seizures, rushed over to help. They told me they'd be happy to drive me to the hospital in their truck if I would pay for the gas. So I did."

Carol was taken to the American Hospital in Puerto Vallarta for diagnosis and treatment. Her medication, which costs \$88/week, is expensive but has greatly reduced the number of seizures.

But no, that wasn't the end of her physical woes. Carol had to stay alone on *Digital* in Marina Vallarta because John had previously been robbed of his

IN LATITUDES



LATITUDE/NICK

Men and ships rot in port. And based on the Stubbs' experience, bikes rust on boats. Would a coat of WD-40 have helped?

passport in Acapulco, and had to return to Texas to get a replacement. Concerned about his wife's health, John had arranged for some people in the area to keep an eye on her.

"Our dinghy was in the water and losing air," says Carol, "so I got the extension cord and the Shop Vac to pump it up. Unfortunately, there was water in the dinghy, I was barefoot, and the live end of the extension cord dropped into the water. I was getting shocked like crazy and started to shake. Juanito, a guy on a nearby boat who was keeping an eye on me, and who knew my medical history, assumed I was having another seizure. I grabbed the extension cord and tried to pull it apart from the Shop Vac plug, but I started getting shocked even more and couldn't even let go of it. Juanito finally figured out what was going on and ripped the cord out of my hand."

"For the next 3.5 hours I lay on the dock, with my whole body feeling like

pins and needles," says Carol. But it was also the first time in three days that I didn't have a seizure. So when I told John over the phone, he said, "That's really great. Now all I have to do is fire up the gen set and attach the leads to your nipples with alligator clips and you won't have any more seizures."

Carol laughed like crazy when she heard that.

Anyway, John and Carol didn't have any more problems on their way to San Diego, and we're thankful for that.

— latitude 07/15/10

Santa Barbara A Sailor's Mini-Guide

When it comes to beautiful harbors, none in Southern California can match the nearly 1,200-berth Santa Barbara Municipal Harbor. The view from boats toward the white sand, green grass and palm-lined shore, backed by the green foothills of the Riviera and Montecito, and the up to 4,000-ft tall Santa

Ynez Mountains may not be quite as gorgeous as Beaulieu sur Mer in the South of France, but it's close.

The Santa Barbara YC, located on the sand, just a winch handle's toss from the surf, has only one end-tie for yacht club members with reciprocal privileges. You get one night free, then up to a week at 60 cents/ft/night (for up to seven nights). Since there is only one berth, reservations are highly recommended, and there's no guarantee they'll have space.



LATITUDE/RICHARD

Santa Barbara surf . . . ah, not so appealing.

If the YC dock is taken, you have to come to the head of the harbor to Harbormaster's Dock to sign up for a slip and have dye tabs put in your heads. In recent years the fees have jumped from 60 cents/ft/night to 90 cents/ft/night. You can stay for two weeks, and if you're willing to pay double, you can stay another two weeks. If you leave for five days after the first two-week period, you can come back for two more weeks and get the lower rate once again. The harbor does not accept reservations, and does not guarantee they will have a slip for you. If you're a cheapskate or the marina is full, you can anchor off Ledbetter Beach or to the east of Stearns Wharf between the limiting buoys. The latter is much more popular right now, with 75 boats on the hook to Ledbetter's zero. If there's a good swell running down the Santa Barbara Channel, you may roll your brains out. The permit for tying your dinghy to the harbor dinghy dock costs \$50 a year — no matter if you come in for one day or 365 days. So

David Crosby's 60-ft schooner 'Mayan' has been in the harbor a long time. You can have her for a mil, and rights to the berth for another mil.



LATITUDE/NICK

CHANGES

some folks tie their dinghy to Stearns Wharf and climb one of the tall ladders. When we checked the dinghies there, one had a baby sea lion in it and another had snagged on a piling and was getting destroyed. For some silly reason jumping off the wharf is prohibited.

COURTESY ISIS

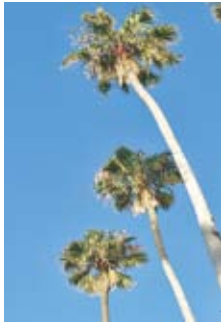

Palms and blue sky, two Santa Barbara signatures — despite frequent fog.

Because of all the commercial activity — oil rig support vessels, the fishing and urchin fleets, and countless tourists — and the pleasure boat activity, Santa Barbara is an unusually busy and interesting harbor. Nonetheless, it's kept clean, and the berth-holder heads and showers are decent enough. Within a very short distance of the marina is lots of nice sand to lie on and grassy picnic areas with benches and BBQs. But the water is cold — 59 degrees in August! — littered with seaweed, and a not very appealing color.

Santa Barbara has a strong Spanish history and favor that can be seen in the public and many commercial buildings, many of which are within easy walking or biking distance of the harbor. If you've got a broken leg, there are buses that run up State Street — the main shopping and restaurant area — from the base of Stearns Wharf, which is also worth a visit. The best distance walk is east from the harbor along Shoreline Drive, which turns into West Cabrillo, which turns into East Cabrillo. You want to continue all the way to East Beach, because if you don't, you'll miss all the lovely young women in bikinis playing beach volleyball.

There's a bike path along this same route, but you'll want to keep on going

Need to haul in Santa Barbara on your way to the Ha-Ha? Damon Hulst has a Marine Transport to lift you out. And 'Profligate's' original mast.

COURTESY ELVIS



as close to the water as you can, past the Four Seasons Biltmore Resort, to Fernald Point, where the road ends and you have to turn back. The walking and biking trips both take about an hour at a leisurely pace, and feature some lovely views. If you don't have a bike, you can rent one at the foot of State Street. If you're a lap swimmer, the 50-meter Los Banos del Mar public pool is but a stone's throw from the northwest side of the harbor. The fee is reasonable, but for some reason it's only open for short times at weird hours.

If you need a car to drive to Costco in Goleta, Enterprise will pick you up from the harbor. If you need a vacation from the boat after a rough trip down the coast, you might want to use the car to drive: by the mansions of Montecito; up windy and dramatic Gibraltar Road to Camino Cielo, then along the ridge of the Santa Ynez Mountains; down to the wineries of the Santa Ynez Valley; or even to Red Rock or the wild back country destinations of Figueroa Mountain and Zaca Station. You can do most of these in a full day or a few in half a day.

For eats, we like the little sushi place at the head of the harbor for lunch, and the tiny Minnow Cafe, a few feet away, for breakfast. For those who like to stretch their legs, we recommend State Street's All India all-you-can eat lunch buffet for \$10, and Saigon Restaurant for Pho for lunch or dinner. This being a tourist town, there are 100 other restaurants of all types and prices on and around State Street within easy walking distance. If you have crew that need to leave your boat or crew that need to join your boat, the train station is just a quarter mile from the harbor. It only takes about two hours for the train to get to downtown L.A., but for some reason it takes about four days to get to the Bay Area — which is why they call it the Coastal Turtle.

For shopping, Doña de Mallorca likes the little Mexican market at the corner of Castillo and West Montecito, which is about a half-mile from the harbor. "The people who run it are so friendly!" The closest big market is Ralph's a mile away on West Castillo, while the closest Trader Joe's is about a mile-and-a-half away at Milpas and the 101 freeway. They are easy to walk to, but if you're buying refrigerated items or heavy stuff, you probably want to take a taxi back.

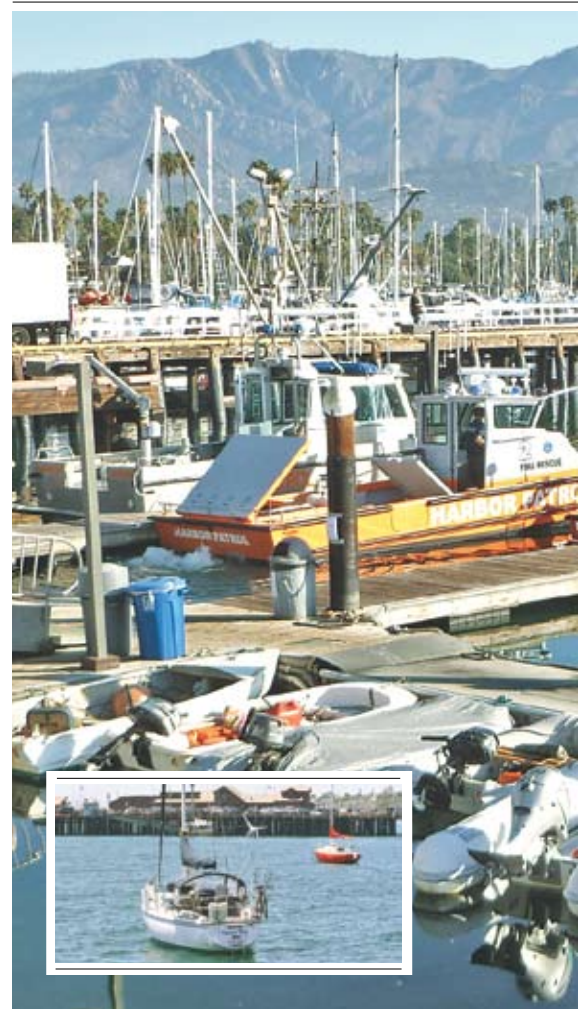

There is a basic West Marine in the harbor and a more extensively stocked one near Trader Joe's. If you need to haul your boat, our friend Damon Hulst runs Harbor Marine Works, the only yard in the harbor, and will happily lift your boat.

Santa Barbara is not only a great place to stop on your way south — hopefully for the start of the Ha-Ha — but is also the gateway to 25-mile distant Santa Cruz Island. Our old friend Mike Pyzel, who still has the Cal 28 *Caballo Blanco* that he bought in '71 and sailed in the first Singlehanded TransPac in '79, says it's a nice reach across to the island and a nice reach back. He should know, as he's made the crossing a mind-boggling 600 times!

— latitude 08/18/10

Cruise Notes:

All other things being equal, the bigger the catamaran, the less likely she is to flip — but it's still possible. This was proven in early August about 120 miles west of Niue when American Kelly



Spread; The Harbormaster's dock at Santa Barbara. Inset above; The Los Banos pool. Inset left; Two of the 75 anchored-out boats.

Wright's Atlantic 57 **Anna** was blown over by winds gusting to at least 62 knots. The cat reportedly had been sailing normally in less than 20 knots of wind under a reefed main and a self-tacking jib, when a squall approached that looked no different than any of the others in the previous 24 hours. But this squall packed a terrific punch. Before Wright, who is from Santa Fe, and crewman Glen McConchie, who is from Christchurch, New Zealand, could get both the sails down, the cat was already going over. The men would spend about 15 hours on the overturned cat before their EPIRB brought a Royal New Zealand Air Force Orion, which in turn directed the ship **Forum Pacific** to their rescue. Both of the men were in good physical condition when they were picked up. **Anna**, which is a lighter and longer version of Chris White's respected Atlantic 55 design, was launched in Chile in May of '09. She was then sailed 8,000 miles in the South Pacific, and was on

her way to Tonga to help with whale research when she went over and ultimately had to be abandoned. According to Wright's website, he previously owned an Atlantic 42, switched to a powercat, then switched back to the big sailing cat. Wright reports having 30,000 miles of ocean experience.

Unable to reach Wright by press time, we spoke with designer Chris White, who has been sailing **Javelin**, his Atlantic 55 cat, in the Caribbean for much of 2010. White said **Anna** is only the second of his cats to have flipped in 20 years, the other being an Atlantic 42 on Lake Michigan. White, who had been communicating with Wright by email, told *Latitude* that both capsizes were from wind alone and had the following in common: 1) Neither captain thought a capsizes was a possibility until it was too late. 2) Both boats were under autopilot all the way through the capsizes. And, 3) The mainsheet didn't get eased or released.

White thinks it's important for all sailors — but cat sailors in particular — to understand that

as the wind speed doubles, the force on the sails quadruples. So in the case of **Anna**, where the wind went from under 20 knots to over 60 knots, the pressure on the sails increased by more than nine times! White recommends that cats be well-reefed in areas of squalls, partly because they don't lose much speed by being reefed; that the autopilot be turned off several minutes before a squall hits; that a human take the helm and be ready to luff up or bear off depending on the circumstances; that sheets, especially the main sheet, be ready to be eased quickly; and that the engine be started in case there is a massive windshift and help is needed bringing the cat into the wind to drop the sails.

"**Anna** was a well-built and extremely seaworthy catamaran," White told us. "Her loss has been the proverbial 'wake up call' to all of us who sail catamarans. The cruising catamaran is normally so forgiving that we can get lulled into complacency, so we have to remain vigilant and have a plan for dealing with sudden massive increases in wind speed and changes in wind direction." For White's detailed analysis, visit www.chriswhitedesigns.com.

Update: On August 19, about 20 days after **Anna** flipped, she somehow drifted unscathed through the East Passage of the outer reef at Vava'u, Tonga, but was then damaged on an island. She was later taken to a mooring at Neiafu. There is a great YouTube video titled 'Atlantic 57 catamaran capsizes'. After 15 hours on a upturned cat, the two crew members look as though they'd just come aboard after a great swim. The moral is if you're going to flip a cat, do it in the tropics! And if you're going to flip in cool or cold waters, have full wetsuits or survival suits.

Double Update: After this month's *Changes* went to press, we received much more information on the capsizing of **Anna**. Please see *Sightings*.

Doing it backwards? Having sailed from Australia to New Zealand to Hawaii to Alaska, Dan and Carol are getting ready to sail to Mexico.



CHANGES

Shortly after we got the news of *Anna* flipping, Dan and Carol Seifers of the Pt. Richmond-based *Seawind 1160* (38-foot) **Caprice** took an end-tie across the way from **Profligate** in Santa Barbara. In their 60s, the couple decided to sell their Gemini cat and fly to Australia to buy the *Seawind*. Not only did they buy her, they also cruised her to New Zealand, then all the way to Alaska, then back down to the Bay Area. Knowing they have their open ocean sailing chops, we asked Dan what sail they carried when they had up to 37 knots of wind from Arguello to Conception. "We shortened down to a triple-reefed main with no headsail," he replied, "and we were still doing 9 knots." Seifers agrees with White, that as long as there is a decent breeze, a reef doesn't slow a cat much. After a visit to Catalina, the Seifers will leave their boat in San Diego for a month prior to doing the Ha-Ha and cruising in Mexico.

Pat Rains of the *San Diego Log* has been reporting that the new administration in Panama has passed laws that, when implemented, will allow foreign-registered pleasure boats to stay in



ESCAPADE

One of the many great things about Panama is that the veggie man delivers. And he delivers quality fruit and vegetables.

the country for one or two years — as opposed to what had effectively been a 90-day limit. The cruising permits used to be good for 90 days followed by a 90-day renewal, but Rains says at the end of

'09, some officials would make boatowners leave the country for 72 hours before allowing them to return for a renewal. The new one-year Sailing and Navigation license will be \$5 per year, renewable for a year. The annual Temporary Registration fee for pleasure boats will be another \$180 for boats over 32 feet, and will be renewable for a second year. Rains reports that a new Mariner's Visa is in the works that would be good for 90 days, with a 90-day extension, followed by a 180-day extension. Assuming all these changes do get implemented, it's terrific news for cruisers in and headed to Panama, which is the cruiser favorite in the region. Keep in mind that these rules do not apply to the Canal Zone, which is controlled by the Canal Authority.

"Hey now from Tamarindo, Costa Rica!" writes Stefan Ries of the Banderas Bay, Mexico-based *Triton 28 Mintaka*. "Here's my thumbnail guide to anchorages in Costa Rica: The waves at Tamarindo are of a short period, and there are 100 people out learning to surf. So after a month without much sailing, I'm



OPTIMIZED FOR
ENGINES UP TO
140 HP

Advanced blade design makes fixed props obsolete!

Introducing the world's first feathering prop to offer lower drag, higher efficiency, and fully adjustable forward and reverse pitch. Faster motoring and sailing speeds – improved fuel efficiency – legendary VariProp quality standards.

VARIPROFILE — MORE FOR LESS!

207-354-7064 | info@variprofusa.com | www.variprofusa.com

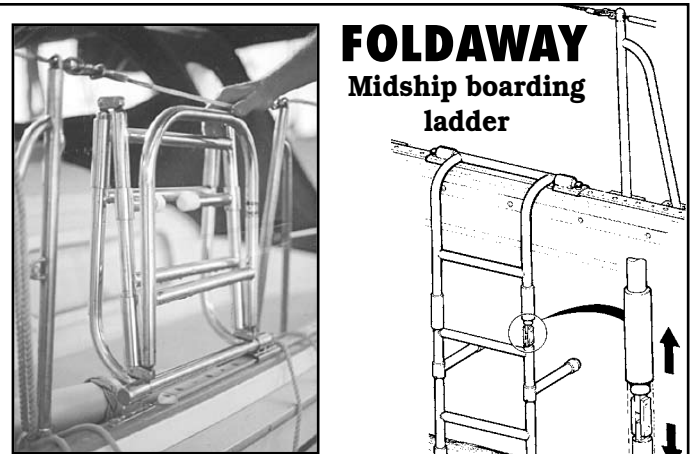

FOLDAWAY Midship boarding ladder

Constructed entirely of polished marine grade stainless steel for superior strength and corrosion resistance. Extended it serves as a swimming ladder as well as for dockside and dinghy boarding. It folds twice to become a compact unit which secures to lifelines or stows in the lazarette.

An innovative locking system assures strength and safety.

MYSTIC STAINLESS & ALUMINUM

(860) 572-9999 Fax (860) 536-2326

www.mysticstainless.com

Fabricators of World Class Custom Marine Hardware

moving again. I had a quiet and peaceful time in the Playa Coco area, where I collected plenty of rainwater, did lots of reading, and completed some small boat projects. Playa Hermosa had the clearest water, and I was able to pick up a WiFi signal on the boat. Playa Panama was the calmest and most protected anchorage, while Mata de Cana had a nice little store ashore. Playa Blanca, which is where I went after I buckled my surfboard at Ollie's Point, had a beautiful beach. After being kicked out of Ollie's for the second time by park rangers, I won't be going back. I spent the last week at Bahia Brasilito, which was lovely. Tomorrow I'll set sail for the Gulf of Nicoya, at which point I'll begin to head back to Banderas Bay to resume work at the Palladium Resort on November 1."

Why did the rangers kick Reis out of Ollie's? "It's \$15 for a day pass," he explained, "and I just don't want to pay that much to surf in Costa Rica."

Readers may recall that Ries is the young German who, since '06, had lived aboard his Coronado 25 **Ky-Mani** at

various locations between Cabo and Puerto Vallarta, most recently just outside the surf line of the Burro's surf spot on the north shore of Banderas Bay. About a year ago his boat was destroyed after she went on the rocks following a sudden blow. Ries' budget for his replacement cruiser was \$5,000, and he managed to pick up the Triton 28 and take off on his current seven-month, sailing-surfing safari to Central America. We love tales such as his, as it once again proves that the important thing is not the size of the boat, but the size of the character of the sailor in the boat. We don't know for sure, but we'll bet 10 cents that Ries is cruising on less than \$500 a month.

Keeping score on Fiji. "We've just



Kent and Jim Milski of 'Sea Level' couldn't stop laughing when they got the bill at an Indian restaurant in Fiji — \$5.50 for the two of them! arrived in Fiji and checked in with the help of the Royal Suva YC," report Jim and Kent Milski of the Colorado-based Schionning 49 cat **Sea Level**. "The club automatically gets a 5 on a scale of 10 from us because of the low cost of services. And they show recent U.S. movie releases for \$4.50 — for the two of us!

SCHOONMAKER POINT MARINA

• IN SAUSALITO •



Call the Marina Office
for more information

415•331•5550

FAX 415•331•8523

or check our web site at
www.schoonmakermarina.com

85 LIBERTY SHIP WAY, #205
SAUSALITO, CA 94965



160 Berth Marina in one of the most beautiful spots on the Bay

- Visitor berths • Guest moorage able to handle yachts up to 200 ft.
- Dry storage • Waterfront Offices • Three-ton Hoist • Windsurfing
- Deli • Beach • Rowing • Kayaking • Yacht clubs always welcome

CHANGES

Last night we ate at a local Indian restaurant, and the bill came to \$5.50 — again, for the two of us. The fact is that Fiji also has the least expensive taxis of anywhere we've been, and among the most friendly people. So that brings their score up to a 9 or 9.5. The only drawback so far has been the paperwork, but even the officials who handle it are really friendly. What a pleasant surprise! So we give Fiji a 10."

Confirming the cruiser-friendly prices in Fiji are Puddle Jump vets Kirk, Cath and Stuart McGeorge of the St. Thomas-based Hylas 49 **Gallivanter**. "The prices here are a welcome relief after French Polynesia," writes Kirk. "The total cost of checking into Fiji, including the cruising permits for all the western island groups, was just \$40. And the farmer's markets offer the most bounteous provisioning we've found in both hemispheres of the Pacific! At present, *Gallivanter* is hauled out at Vuda Point for an overdue bottom job and minor repairs to damage suffered during the *two* recent tsunamis. It's been 34 months since our last haulout in the U.S. Virgins, but once we got our boat in the slings, we decided to cancel the pressure wash of the bottom. Our nearly



JULIE TURPIN

Kirk, Cath and their young son Stuart — aka 'Arrr Boy' — have had many adventures since this shot was taken last June in Moorea.

three-year-old Jotun bottom paint was still toxic enough to prevent any serious fouling! That paint is unavailable here in Fiji, so we're using the local brew to ease the pain of our upcoming plan to clear into Australia — which wants to

see receipts and maintenance logs for bottom paint.

"Nevertheless, the prices are right here in the boatyard, too," continues Kirk. "The bottom job — which includes having the bottom faired, sanded and painted — comes to just \$1,400 for materials and labor. That also includes having minor gouges ground out and filled, the waterline gel coat sanded, primed, and painted higher on the hull, as well as getting the topsides patched, polished and waxed — and the cove stripe repainted! As a result, all I will be doing is the interior varnish and some minor plumbing upgrades. The haul-out and back-in charges are \$200; lay days are less than \$20; and Med-style berthing in the marina is less than \$13/day for our 49-ft boat. When we left the Virgin Islands, a mooring buoy at the Bitter End YC was \$40 per night! There's more good news on the money front, too. The resort next to the boatyard offers a cruiser's discount for their private garden bungalows by the pool, dropping the total to less than \$40/night. Draft beer for \$1.50 helps ease the pain of singing



**West Marine®
Rigging Service**

Your Sailing Resource!

- Specialty Hardware
- Technical Apparel

Visit westmarine.com to shop our **New One Design** offerings



Complete Rigging Headquarters!

Installation • Lifelines • Running Rigging
Standing Rigging • Dock & Anchor Lines

Mobile Rigging Service Available

Contact us for all of your Rigging Needs!
888-447-RIGG

or visit our Onsite Rigging Locations in:

<p>Alameda, CA 730 Buena Vista Ave. (510) 521-4865</p>	<p>San Diego, CA 1250 Rosecrans St. (619) 255-8844</p>	<p>Seattle, WA 1275 Westlake Ave. N (206) 926-0361</p>
---	---	---

westmarine.com/rigging

COVER CRAFT

DURABLE GOODS

Better Materials
Thoughtful, Innovative Designs
Top Quality Workmanship



All sewing in Tenara thread

- Classic dodgers and biminis
- Drop-top folding dodgers
- Enclosures • Custom canvas

1230 Brickyard Cove Road, #106
Pt. Richmond, CA 94801
In Brickyard Cove Marina

(510) 234-4400

Quality Yacht Canvas

the boatyard blues, and the three of us can enjoy a nice dinner at the resort for a total of \$8 to \$15 — in the light of tiki torches, no less. By the way, we attended a traditional wedding last week, and my wife, son, and I are now, officially, fire walkers! Besides a few savages and the daring crew of *Gallivanter*, nobody else had the balls to even approach the glowing fire pit. Tourists!”

Reciprocity has its benefits — including saving money and making lots of great friends. Thanks to the May issue article in *Latitude* by Bruce and Lina Nesbit of the Mill Valley-based Olson 34 **Razzberries** about how great it can be to take advantage of reciprocal privileges at yacht clubs in Southern California, Bob Bahlman and Margie Hewes of the Sausalito-based Catalina 30 **No Name** decided to do just that. “It turned out to be terrific advice,” says Margie, “as we not only saved money, but even more important, we were welcomed at every club with open arms, and we met some really wonderful people while doing it. We highly recommend it.”

While berthed in Santa Barbara — *Profligate’s* hangout for August — we

were visited by Leonard Peckett and Wilma Snyder of the anchored-out Emeryville-based Horstman 45-ft trimaran **Midnight Sun**. The couple left Northern California in mid-June for what they intend to be a full year of cruising in Mexico. The tri, which was built by Leonard’s father in a barn in Newark many years ago, previously sailed to Mexico as part of the Ha-Ha V in ‘98. “My father was much more of a boatbuilder than a sailor, so doing the Ha-Ha was his dream and my gift to him,” says Leonard, who had bought the tri from his dad two years before. “Dad loved the Ha-Ha — although having built the boat, he felt ultimately responsible for everything and didn’t get much sleep. But she’d been built really well using airplane construction of cold molded



After years of hard work raising kids and working on construction projects, Wilma and Leonard are loving the relaxation of cruising.

double-planked mahogany plywood over fir frames, so there was nothing for him to worry about.”

While Wilma has done a little sailing on San Francisco Bay, this is her first extended trip, and she left her grown kids behind. “I’m really enjoying the relaxation of being on the boat,” she says,

ENSENADA'S ONLY RESORT MARINA

\$12.60 PER FOOT

SHUTTLE SERVICE TO USA! AVAILABLE

Enjoy our 2 month special rate that includes, live aboard, access to our amenities, complimentary weekly shuttle to town, WiFi & Cable T.V. service included. Plus get a preferred discount on clearance assistance with Customs. Only fuel dock in Ensenada | Pets are welcome

OFFER EXPIRES ON NOVEMBER 30, 2010. RESERVATION CODE: CRUISERS 2010
Rates shown are in USD. Additional taxes/fees or restrictions may apply.

FOLLOW US IN:

HOTEL CORAL AND MARINA

1 (866) 302-0066 | VHF 71
marina@hotelcoral.com
www.hotelcoral.com

Baja Ha-Ha Special!

\$1.25 per foot per night

Complimentary coffee, tea & hot chocolate every morning!

PIER 32 MARINA

Paradise awaits you at San Diego Bay's Finest Marina

Deluxe Showers, Boater's Lounge, Pool, Spa, Laundry Restaurant and Chandlery

A mini resort with putting green, basketball, horseshoes, exercise room, bikes and more. A perfect spot to rest up and gear up before the Ha-Ha. Monthly rates also available.

Pier 32 Marina
3201 Marina Way, National City, CA 91950
For reservations call 619-477-3232
www.pier32marina.com www.mywaterfrontgrill.com

CHANGES

"particularly out at the Channel Islands. At Santa Cruz Island we anchored at Fry's, Scorpion, Yellow Bank and Pelican." And the couple found the fishing and diving to be great. "We caught some nice sheephead, perch, opal eyes, and picked up some scallops for some killer scallop dinners," says Leonard.

The relaxation of cruising is something that Leonard appreciates as much as Wilma. Having spent the last seven years doing well as a union carpenter on very large concrete projects, Leonard has taken advantage of the construction slowdown to repower *Midnight Sun*, re-do the electrical system, and to take a year off. "Everyone on the water is so relaxed," he says, "it's a great way of life."

"What the hell is 'home' anyway?" asks Gary Burgin of the Santa Cruz-based Marples 55 cat **Crystal Blue Persuasion**. Burgin did the '08 Ha-Ha with his dad Larry, then continued down to and through the Canal, and then up to the Caribbean coast of Mexico, hoping to get a charter business going. That didn't pan out, as is the case with most foreign charter efforts in Mexico. So after having to



Who is this guy and how did he get so tan and lean? Simple: he lived the active cruising life for a couple of years.

deal with some mechanical and other boat problems, Gary headed back to the Canal and up to Santa Cruz. "After 5,000 miles and four months at sea," he announced on May 18, "I'm back home." The next day he made the following post on Facebook:

"I'm going down to the harbor tonight to go sailing. Am I sick or what?"

While Burgin's charter attempt may not have resulted in an improvement in his financial condition, it looks like it improved his physical condition. When he took off on the Ha-Ha, he was big and muscular. Based on the photo at left, he's kept all the muscle but shed a bunch of bulk. Good on you, Gary, that's how we all ought to look! As much as he'd like to return to Mexico with the cat, he says he's got a lot of work to do first. So he's travelled to Alaska — not by boat — to work in the construction industry. That should keep him fit, but he's going to lose that tan.

Why would Burgin want to return to Mexico when the charter effort didn't pan out? It's the people. For instance, he reports that when he pulled into Turtle Bay during the Baja Bash, he was so low on funds that he couldn't afford to buy diesel to motor the rest of the way home. Somehow the folks at **Services Annabelle** caught wind of this, and came forward to offer Burgin hundreds of



MARINE INSURANCE SPECIALISTS

Your best source for Yacht and Boat Insurance tailored to your needs and competitively priced

We Insure:

Sail or Power ■ Classic or Contemporary
Fiberglass ■ Aluminum ■ Steel ■ Wood

At Heritage Marine Insurance you will find knowledgeable insurance professionals who provide the best service and the finest coverage available today.

Please contact us for a quote

www.heritagemarineinsurance.com

800-959-3047

Fax 860-572-5919

Email: classics@heritagemarineinsurance.com



A wild downwind ride.

A new 20-foot club racer with carbon-fiber keel, spars, bowsprit and rudder. Lightweight and trailerable.

LOA	LWL	Beam	Draft	Displ.	Spar
19' 6"	18' 0"	5' 11"	4' 6"	835	Carbon

Ready to Race for \$24K

landingschoolboats.com

207-985-7976

dollars of diesel based solely on his word that he would pay them back. Good ol' **Mexico**. If everything goes to hell, that's where you want to sail away on your boat, because the people are so friendly and because they know how to be happy and have fun without lots of money or material goods.

"I sailed back to the States from Banderas Bay in May aboard my trusty — but lightning debilitated — Catalina 470 **Location**," writes J. Mills, formerly of Newport Beach. "It was an 'interesting' 45-day trip, not only because I had to do it singlehanded and because the winds and seas were on the nose, but because I had no autopilot or other electronics beyond a handheld GPS and a depthsounder. This was a result of the lightning strike — and the insurance company dragging its feet with the settlement. Out of necessity, I quickly became intimately reacquainted with the fine art of balancing the sails and the rudder with a makeshift 'vane' system made from a line running between the main boom and the wheel. Sometimes it even worked. The challenge of the trip was

more than I expected, and it took longer than I expected, but I'm glad I did it. Besides, I had no other option but abandon the boat in Mexico. After I arrived home in June, a change in my marital status and the lack of jobs meant I had to give up the boat and sell everything. I'm now living on a horse farm in Kentucky. Losing everything can be quite liberating — but I can't recommend it as a way of life."

We're sorry to hear that you had to give up your boat, and wish you and everyone else in your situation the best during this terrible jobless recovery.

Can it really be that Mike Pyzel, as we reported in our Santa Barbara Mini-Guide a few pages back, has really sailed between Santa Barbara to Santa Cruz Island 600 times? It can. He's not taking the Cal 28 **Caballo Blanco** he bought 39 years ago over to the island as much, but



Mike doesn't need an iPad to get to Santa Cruz Island because his 'white horse' has been there so many times she knows the way.

that's only because he and his lady friend Valerie Craft take her boat, the Catalina 27 *Sun Spot*, instead. The two not only trade off whose boat they take, but who is going to be captain for the trip.

The good news about such island trips is that they are a reach both ways. If you sail toward the west end of the island — a tight reach — it can get very windy in the afternoon. "At 2 p.m. on summer afternoons, especially when

Your secret paradise...



in
Nicaragua

Located in a beautiful sheltered lagoon on the north Pacific coast of Nicaragua, Marina Puesta del Sol is your premier cruising destination in Central America.



Aserradores, Nicaragua ♦ 011 (from US and Canada) 505-880-0019
mpuestadelsol@yahoo.com ♦ www.marinapuestadelsol.com ♦ USA 408-588-0017

Ventura Harbor Boatyard

A First Class Full Service Facility

(805) 654-1433

Official
Sponsor
2010
BAJA
HA-HA



Two Travelifts ~ Haul Outs to 160 Tons

Experienced Staff □ Competitive Rates

"Do-It-Yourselfers Welcome"

1415 Spinnaker Drive, Ventura, CA 93001

www.vhby.com

CHANGES

there's a 'cap cloud', it's almost routine for it to be blowing 30 to 35 knots from Santa Rosa to the western end of Santa Cruz Island," says Pyzel. "That's where I teach storm sailing techniques. But as you move east along either side of Santa Cruz, the wind drops dramatically. When Pyzel isn't sailing to one of the Channel Islands, he's one of the busiest surveyors in the Santa Barbara-to-Oxnard area. "Today I surveyed an Islander 30 that a father and son had bought for just \$400. She didn't have an engine, but otherwise she's a fine boat, and it's going to make a terrific father-son project." And no, the \$400 was not a typo.

"There's a little shindig going on not far from where we're moored at the New York YC's facility in Newport, Rhode Island," wrote Kevin Rooney of the Davenport-based Santa Cruz 40 **Kokopelli** back in July. If we're not mistaken, he's been out cruising *Kokopelli* since the end of the '04 Ha-Ha. "We've been cruising Maine most recently, but are now headed down to New York to do the 'Round Long Island Race. After that, we'll head up the Hudson River. We miss California, but



Southbound cruisers alert! Whales are out in force, from this unidentified whale off Anacapa to blues just four miles from Newport Harbor.

there is so much to see here in the East — and it's always just a half-day's sail to the next place. At \$3.50 to \$5 foot/night, slips are bit pricey, so it's fortunate there are plenty of moorings, with free launch service, for about \$35/night. There are also some great yacht clubs."

Over the years, **Tenacatita Bay**, on

Mexico's Gold Coast, has been one of the most popular and tranquil places for cruisers to gather. It's so nice that many cruisers stayed for weeks if not months. As a result, Tenacatita vets have been very disturbed to learn that approximately 800 of the wonderful locals who lived, worked and provided cruisers with services on the northwest shore of the bay were forceably evicted last month by state police. What's more, all their structures were bulldozed and their possessions thrown away. The explanation is that a wealthy Mexican who wants to build a high-end resort finally won a decades-old court battle in which he'd asserted that he owned the land. This comes as a shock to some of those evicted, who have papers saying they have title to the land. Because much of the bay is not affected by this strife, it's our belief that lots of cruisers will gather in Tenacatita once again this winter, and will have services provided. But Tenacatita vets will have heavy hearts, knowing that many of the wonderful people who worked and laughed with them for so many years are no longer there.

HONDA
MARINE
IT'S ALL ABOUT POWER.

caribe
INFLATABLES

Aquapro
INFLATABLES

MVP Light
SERIES L8, L9, L10

HONDA
MARINE
IT'S ALL ABOUT POWER.

TOHATSU
outboards

Achilles

**We've been THE Bay Area authority for
inflatables and outboards for more than 35 years.**

Call us today for quotes.

Voyager Marine
1296 State St.
P.O. Box 246, Alviso, CA 95002-0246
(408) 263-7633 • (800) 700-7633
Open Tuesday thru Saturday

Custom Canvas & Interiors

The Gianola Family has been designing and fabricating custom canvas and interiors since 1969. Gianola Canvas Products offers you the best in quality, more choices, and personal service.

265-B Gate 5 Road
Sausalito, CA 94965
(415) 332-3339
www.gianolacanvas.com

deWitt

Jim turned 80 this year!
Keep your eyes open for
upcoming special dates here at
the Gallery in Point Richmond.

DeWitt Art Gallery & Framing
121 Park Place, Point Richmond, CA 94801
(510) 236-1401 • (800) 758-4291
www.jimdewitt.com

www.dewittgalleryandframing.com

Wednesday-Saturday 11:00-7:00

Sunday 9:30-5:30



*Let's take a look back at some
old work he's done over the years!*

More to come...

Welcome to Mazatlan...



Marina El Cid style!

A CRUISER'S PARADISE IN THE HEART OF MEXICO'S
LUSH TROPICAL COASTLINE AND BEAUTIFUL ISLANDS

*Complete, Modern Amenities, Including
Marina-Wide High Speed Wireless Internet Connections!*



www.marinaselcid.com
011-52 (669) 916-3468
marinaelcidmazatlan@elcid.com.mx

The Cruiser's Home in Mexico

Come to Mexico and repair your boat at

OPEQUIMAR

MARINE CENTER CENTRO MARINO

Puerto Vallarta



**88-ton (max)
Travelift!
Length to 100'
Width to 23'**

MÉXICO AEROTRON RIVIERA NAYARIT PUERTO VALLARTA
www.aerotron.com El Tablero del Pacífico Mexicano Where Mexico Comes to Life

www.opequimar.com

fuel dock • full service boatyard • brokerage • 88-ton Travelift

Please read before submitting ad

Classy CLASSIFIEDS

Here's What To Do:

Write your ad. Indicate category. Remember price and contact info. We make final placement determination.

Count the words. Anything with a space before and after counts as one word. We will spell-check, abbreviate, edit, as necessary.

Mail your ad with check or money order, deliver to our office; **OR, for the best – and most exposure – of your classified ad...**

Submit your ad safely online with Visa, MasterCard or AmEx at: **www.latitude38.com**

Ad will be posted online within two business days, appear in the next issue of the magazine, and remain online until the following issue is released.

PERSONAL ADS

1-40 Words.....\$40
41-80 Words.....\$65
81-120 Words....\$90
Photo.....\$30

• Personal Advertising Only •
No business or promo ads except Non-Profit, Job Op, Business Op

'Trying to Locate' Ads are for those searching for lost boats/people – not shopping – and cost **\$10 for 20 words max**

FREE Online Ads are for a private party selling a boat for less than \$1,000 – or gear totalling under \$1,000. (One per person; must list prices in ad.)

All ads will be set to fit *Latitude 38* standard • Re-Run Ads: Same price, same deadline

BUSINESS ADS

\$70 for 40 Words Max

• All promotional advertising •
1 boat per broker per issue
Logo OK, but no photos/reversals
No extra bold type • Max: 12 pt font
Artwork subject to editor approval.
Biz ads will not appear on website.

DEADLINE

is **ALWAYS** the **18th at 5 pm**

for ad to appear in the next issue.

Due to our short lead time, deadlines are very strict and include weekends & holidays.

Sorry, but...

- No ads accepted by phone
- No ads without payments
- No billing arrangements
- No verification of receipt
- We reserve the right to refuse poor quality photos or illegible ads.

Latitude 38 15 Locust Ave, Mill Valley, CA 94941 Questions? (415) 383-8200, ext 104 • class@latitude38.com

WHAT'S IN A DEADLINE? Our Classified Deadline has always been the 18th of the month, and it's still pretty much a brick wall if you want to get your ad into the magazine. But it's not so important anymore when it comes to getting exposure for your ad. With our new system, your ad gets posted to our website within a day or so of submission. Then it appears in the next issue of the magazine. So you're much better off if you submit or renew your ad early in the month. That way your ad begins to work for you immediately. There's no reason to wait for the last minute.

9-FT LIVINGSTON, 2007. Emeryville, CA. \$650. Certified for 4 passengers and up to 8hp. Lightly used and in excellent condition. Very stable/easy boarding. Includes oars and locks. Snap davits available for \$30. jhbueto@surewest.net.

24 FEET & UNDER

20-FT FLICKA, 1992. San Carlos, Mexico. \$35,000. *Dulcina* is a beautiful 1992 Pacific Seacraft Flicka! She is 100% turn key. See website and/or call Randy. [http://picasaweb.google.com/h/sredir?uname=sirena.jh&target=ALBUM&id=5484225830370998161&authkey=Gv.\(011-521\)622-120-1344](http://picasaweb.google.com/h/sredir?uname=sirena.jh&target=ALBUM&id=5484225830370998161&authkey=Gv.(011-521)622-120-1344) or randy.ramirez@sbcglobal.net.



CATALINA 22 MK II, 1999. San Mateo. \$9,500. Excellent condition! Fin keel (fixed), Dacron + Kevlar sails, 2 spinnakers (one is AIRX), 7.5hp Mercury OB, full cover, autopilot w/remote, solar panel, cushions. Ready to sail, turn-key boat! (408) 247-1302 or brad_blackmon@yahoo.com.

19-FT WEST WIGHT POTTER, 2001. Folsom Marina #B37. \$9,500. Complete package, including trailer with extension hitch, sails, sail covers, stove, Porta-Potti, cushions, 4-stroke 5hp Nissan motor, etc. Sleeps 4. Contact for complete details. (916) 409-0988 or bhuth@wavecable.com.



20-FT SANTANA, 1972. San Diego. \$3,900. Trailer, 2.5hp O/B, 2 mains, genoa, jib and 2 spinn. Cushions, full cover, lifelines stanchions, pulpit. Very clean. Race ready or overnight to the island. (760) 727-8910, (760) 802-2034 or servpro8724@roadrunner.com.

DINGHIES, LIFERAFTS AND ROWBOATS

10-FT WALKER BAYS. \$1,250 with sail kit, \$750 w/o. 2 excellent condition, lightly used. These are sturdy little boats and lots of fun. Also, 8-ft fiberglass dinghy with sails. Great shape and great little boat; \$500. (530) 637-1151.

18-FT AEOLUS/GRUENWALD DORY. Napa, CA. \$3,500. Classic Aeolus/Gruenwald dory in excellent condition with new oars, custom fitted canvas cover, motorwell for small outboard, new trailer with oil lubed bearings. Rows beautifully, but can be motored when desired. (707) 265-8415 or rdoormann@vom.com.



21-FT SEA PEARL, 1986. Tempe, AZ. \$6,000/obo. Sea Pearl "ketch cat" sailboat with teak/ mahogany deck, galvanized trailer, dual ballast, centerboard, antifoul paint, cushions, motormount, cover, center and captain's seat. This is a fun boat! www.marine-concepts.com. Contact Kevin at (602) 821-0284, (480) 759-0318 or k-mart@cox.net.



23-FT DEHLER SPRINTA SPORT, 1981. South Beach YC, SF. \$3,500. Dehler design by Van de Stadt, *Momentum* is an exciting racer/cruiser with rebuilt outboard, new Pineapple mainsail, Harken headfoil and berth covers. Fractional rig. <http://sites.google.com/site/sprintasport23/> (415) 683-3632 or tanyak@gmail.com.

24-FT MELGES, ALAMEDA BOATYARD. \$20,000. Hull #14. Race ready. Full boat covers. Contact Frank. (512) 750-5735 or cabosportsfrank@yahoo.com.



24-FT SAN JUAN, 1974. \$3,400 w/motor - \$3,000 w/o. Ready to sail. Newly refurbished trailer with new tires. Rebuilt 7hp Evinrude outboard motor, optional. Call Edward. (530) 938-4558.

Yacht Repair
Design / Consulting

Custom Interiors
Exterior Joinery



STEVE'S MARINE WOODWORK

60 C Libertyship Way, Sausalito
jonessail@aol.com • (415) 332-2500

N.E. MARINE TITLE

Coast Guard documentation • Title/lien searches • Transfers • Mortgage filing • Escrow services
Local closing facility for brokers or private transactions
30 years experience of doing it right the first time

1150 Ballena Blvd, Alameda, CA • (510) 521-4925



NOR-CAL COMPASS

Adjustment • Sales

Authorized Compass Repair

Hal McCormack • norcal.compass@verizon.net • Phone/Fax (415) 892-7177

BOAT • LETTERING

alphaboatsue@aol.com • (510) 599-1197 • www.alphaboatgraphics.com

Creative and durable lettering and artwork for your boat

23-FT SANTANA 2023A, 1993. \$8,000. Easily trailerable, dry weight 1580#, water ballast 1300#, very stiff, w/5hp Mercury starts easily, roller furling main and jibs 90% 150%, Harken winches, Icom VHF, depth sounder, portable toilet, dry-sailed. (530) 432-9468 or (530) 432-4545.

21-FT US YACHT, 1982. Livermore. \$4,000. Sailboat on trailer, swing keel, perfect for lakes. Sails: 2 jibs, 1 main, 1 spinnaker. Interior cabin with portable toilet. (925) 784-9901 or gerry.laird@yahoo.com.

24-FT COLUMBIA CHALLENGER, 1964. Stockton. \$4,500/obo. Proven racer, new self-tacking/working jibs, swell main, crunchy spinnaker, new elec., VHF, sound wired, depth, speed, smooth bottom, sink w/ice chest, pulpits, tabernacle mast, clean, rigged, sail ready. Newer trailer included. (209) 476-1381 or phil.hendrix@excite.com.

25 TO 28 FEET



26-FT ZAP, 1979. \$7,500. Bruce King foamcore Ultralite. New mainsail, genoa, jib, full spinnaker, and older star cut. New Navtec/Dyform rigging, high-tech halyards. Ballenger spar. Flush deck, open transom. Steady, stable, planing at 12 knots. Many accessories including Mariner 6hp. Must sell. (510) 277-2291.

MCGREGOR 26X, 2001. San Rafael. \$15,500. In great condition. 50hp 4-stroke, main and jib sails, cockpit cushions, sun shade. VHF radio, depth finder, dual batteries. Stove, sail and pedestal covers, bulkhead compass and more. Trailer included. (415) 456-2644.



27-FT O'DAY, 1978. San Rafael, CA. \$11,100. Now 1K below NADA guides. Rare on West Coast. Clean turnkey race winner. Comfortable cruiser. Yanmar diesel. Dual AGM's inverter Martec folding prop. Dripless shaft seal. Profuri AP with remote. (415) 269-3140 or windride27@gmail.com.

27-FT PACIFIC SEACRAFT ORION. 1979. Alameda, CA. \$49,500. *Aphrodite* gave us great memories and adventures in Mexico. Good condition and cruise ready. Cutter rig, Yanmar diesel, Cape Horn windvane, flexible Uni-Solar panels, new asymmetrical spinnaker, propane oven, dodger, more... Surveyed July 2010. (530) 392-5651.

28-FT PEARSON, 1976. Berkeley. \$14,750. Great Bay boat. Complete refit since 2007. New items: jib and furling system, fresh water head, rigging, lifelines, thru hulls, refrigeration, plus... 2005 mainsail, GPS, depth. Bottom job 2009. Pictures online at www.firststannapa.com/IBEX. (415) 205-0687 or (707) 363-3196.



27-FT ERICSON, 1978. Berkeley, CA. \$12,500. Excellent condition and consistently maintained. Great Bay and coastal cruiser. Sleeps 4. Rigged for singlehanding with all lines leading aft. Wheel with pedestal compass, lifelines and nonskid deck. Alcohol stove, sink, icebox and 20-gallon freshwater tank. New holding tank w/sea outlet. Atomic 4 in top condition. Sails include main w/2 reef points, 155 Mylar, 150 and 110 Dacron, 85% w/Harken roller. Spinn rigging. White with green deck and stripe. (925) 376-9361.

25-FT CHEOY LEE FRISCO FLYER. 1964. Monterey. \$2,500/obo. Fiberglass hull, teak deck & wood spars. Bottom painted 08/2010. Teak interior with head & wash basin. Good looking boat at bargain price. Come & get it. (831) 760-2558.

27-FT CATALINA, 1972. Monterey. \$4,500/obo. Good condition Catalina 27. Universal Atomic 4 engine. Head & mainsail good. Engine runs well. Great price. Ready to make a deal on this boat. (831) 760-2558.



27-FT CAL 2-27, 1978. America's Cup Harbor, San Diego. \$7,900. Main, genaker, spinnaker, 2 headsails, roller furling. Outboard motor with warranty, bimini, stereo, VHF, electric head, sailing instruments, self-tailing winches, bottom job 2009. (619) 459-6353, (619) 301-4130 or fstued@cox.net.

26-FT PEARSON ARIEL, 1964. Sausalito. Make offer. Full suit o' sails, 2-speed self-tailing Lewmars, all lines led aft, strong inboard. Stout Bay/ocean boat that sails great, and needs a little dolling up. Perfect beginner boat or cruiser with a few upgrades. Possible Sausalito slip transfer. (415) 225-4319.

26-FT MARIEHOLM FOLKBOAT, 1969. Richmond. \$6,000. Inboard BMW diesel. 2009 Plastic Classic "Fastest Pre '70 boat". Good condition. New rigging Nov. 2008, anemometer, knotmeter. Lots of good sails. Call or email. (510) 932-5802 or beulah49do@aol.com.



27-FT ERICSON, 1976. Alameda (Ballena Marina). \$8,000. Sloop-rigged sailboat. Wheel steering with tiller attachment. Standing and running rigging in good condition. 18hp 2-cyl diesel inboard. Self-furling jib added in April 2008. (510) 205-1973 or mary_wilmot@hotmail.com.



25-FT OLSON, 1988. Alameda. \$9,500. New 6hp Mercury OBM, whisker pole, VHF radio, 2 anchors, cockpit cushions, main, working jib, genoa, new mainsail cover, alcohol stove, 2 coolers, Porta-Potti. Lines led aft for easy singlehanding. Great shape. (510) 995-8852 or tbstrand@comcast.net.

28-FT BUCCANEER, 1979. Phoenix. \$15,000/obo. Center cockpit, positive flotation, 6'2" headroom, aft cabin/double bed, inboard Volvo diesel, Autohelm wheel steering, GPS, depth gauge, radio, refrigerator, stove, solar panel, dinghy w/OB. 2-axle trailer. Pictures on website. www.rhmarx.com. (928) 684-9606 or moondrifter@rhmarx.com.

25-FT OLSON, 1985. Berkeley. \$7,500. Good example of these strong easy to sail boats. Regularly maintained, sailed and raced. Complete package with spinnakers. Good Berkeley berth. See this boat photos at url. General Olson 25 info at <http://olson25.org>. Photos at <http://sites.google.com/site/intrepidschedule/photos-of-intrepid>. Email anawhata@gmail.com.



25-FT SANTANA 525, 1978. Alameda Marina. \$5,000/obo. With a PHRF of 184, this daysailer is a good compromise between race boat and cruiser. Included are: trailer, 1-year-old 5hp Honda outboard, newly recovered cushions, mainsail, genoa, almost new 90% storm jib, spinnaker, Porta-Potti, speedometer/depth-finder, almost new VHF radio/CD player, handheld GPS, handheld radio, boom-kicker, tiller lockdown, padded lifelines, sail cover, anchor, almost new battery, solar recharging panel, life jackets and more. This boat is in fine, but not pristine, condition. It sails great in light winds, but usually requires a reef when going through the "slot" in the Central Bay. Subtracting items from the total package, I could accept a lower price. (530) 990-1071 or ravandenbergl1@yahoo.com.

MCGREGOR 26X, 1997. Lauritzens Marina, Antioch. \$7,700. Good condition, new jib, includes stove, cushions, extras. 50hp outboard needs overhaul and trailer not used recently. Great Delta family boat. Lost job at NUMMI, moving out of state for work. (925) 759-3047 or hartleyd@aol.com.



25-FT CHEOY LEE FRISCO FLYER, 1964. San Leandro. \$3,500. Full keel, fiberglass hull, teak decks, one mainsail, two jibs, new Tohatsu 4-stroke 6hp outboard. Can email last survey from 11/2008. Boom is being refinished. (209) 620-2031 or cbalcom@mac.com.



27-FT O'DAY, 1976. Ballena Isle Marina. \$12,000/obo. One owner boat. Well maintained. Cruise ready. Dodger, 130 roller furler, full batten main, 3/4 oz. asymmetrical spinnaker. Stereo, VHF, wind point/speedo, GPS, depth, autopilot. Full boat cover. (510) 783-0953 or cmdrbob@sbcglobal.net.

WOODRUM MARINE

Specializing in custom interior cabinetry, tables, cabinets, countertops, cabinsoles. For power or sail.

CARPENTRY
Mobile cabinet shop
Contact Lon Woodrum at:
415-420-5970
www.woodrummarine.com

Jack D. Scullion
Yacht Services
jdsyachts@att.net
(510) 919-0001

Rigging
Electronics
Troubleshooting
Electrical Installations
We Gladly Install Gear You Provide

NEILPRYDE



SAILS

MikeMaurice @ YachtsDelivered.com

Power - 45 Years Experience - Sail
Expert- No. Pacific/4Seasons & Bar Crossings
China-Alaska + **1-503-310-7590** - Caribbean



MARINE SURVEYS by Captain Alan Hugenot
Naval Architect • Yacht Delivery Skipper
Accredited Marine Surveyor (SAMS)
Bay or Delta • No Travel Charges • MC / VISA / AmEx
alan@captainhugenot.com • (415) 531-6172

We care about sail care!



San Francisco Service

773 Andersen Drive, San Rafael, CA 94901

T: 415-453-2142 M: 510-333-4644

Hours: 8-5 M-F, Sat. by appointment

SAIL CARE ■ SAIL COVERS ■ YACHT COVERS ■ FLAGS ■ CRUISING PRODUCTS



Faster by Design
www.northsails.com

weatherguy.com

Worldwide Marine Forecasts Cruising, Racing & Commercial Packages Starting at \$65.00 USD

(866) 882-WXGY (9949) toll free
(808) 291-WXGY (Mobile)
(808) 254-2525 (Office)
(808) 443-0889 (Fax)



970 N Kalaheo Ave
Suite C-104
Kailua, Hawaii 96734
info@weatherguy.com

www.weatherguy.com

KATADYN SURVIVOR 35 WATERMAKER

The Survivor is a must for all sea-going vessels and is the most widely used emergency desalinator. It is used by the U.S. and international forces. It is able to produce 4.5 liters of drinkable water per hour. These are unused U.S. government surplus.

Reconditioned by Katadyn **\$950**.
Compare to factory new price: \$1,995.

For more information or
to place an order, please
call one of our sales reps.

Equipment Parts Sales
In the U.S.: (800) 417-2279
Outside the U.S.: (717) 896-9110



COMPUTER ABOARD?

CAPN & Digital Charts
AIS • WiFi • Cellular Amps
SatPhones: Iridium & Globalstar
HF SSB Radio & Pactor Modems
Wireless E-mail



SeaTECH SYSTEMS™

800.444.2581 • 281.334.1174
info@sea-tech.com • www.sea-tech.com

Call for Info on SeaTech Packages and CAPN Demo Disk

27-FT ERICSON, 1973. Sausalito. \$3,000. Great Bay boat - fabulous condition. Reliable Evinrude outboard. Sails in good condition. New main. Spinnaker/pole/tiller. All wood refinished. Really nice sailing boat. Partnership available. www.flickr.com/photos/52429540@N08/4823811467. (415) 602-0310, (415) 384-0194 or mikez97@att.net.

27-FT NOR'SEA 27, 1979. Friday Harbor, Washington. \$35,000/obo. Well-equipped Nor'Sea 27, sailed extensively in the Sea of Cortez, and kept in drydock since 1996. New fuel tank and Yanmar diesel. Visit the website for pictures and information! www.breannemarie.com. (360) 378-3215.

29 TO 31 FEET

30-FT YANKEE S&S, 1972. South Tahoe. \$7,000/negotiable. She's too young for the old skipper! For particulars, call Slava. (530) 644-7406.

29-FT GULF PILOTHOUSE SLOOP. 1982. Caliente Harbor/Bethel Island. \$24,900/obo. Full electronics, Universal 14hp engine, dripless packing, Campbell Sailor prop, furling jib, drifter, spinnaker. Three batteries and charger. Head, two-burner stove, ice box. (925) 437-6592 or david_graas2@hotmail.com.



30-FT CAL (JENSENMAR), 1968. Brisbane Marina, CA. \$8,000 obo. \$10,000 invested at San Francisco Boat Works, 2/09. Bottom painted, Mariner 9.9 outboard rebuilt (less than 50 hrs. since) 110v/12v systems rewired w/new electric panel, new battery and charger. Surveyed 2/09 by Wedlock, Ramsay & Whiting Marine Surveyors at an appraised value of \$14,000. She has two sets of sails, GPS and a mounted VHF radio. Registration paid until 12/31/2011. This is a great first sailboat!!! She is clean and well maintained with all receipts. I am NOT desperate at all, but I DID just get a great deal on my newer boat, so I'm willing to part with this one for \$8,000 for quick sale!! (650) 255-6471 or wm.h@live.com.

29-FT ERICSON, 1972. S.F. Marina. \$18,900. Immaculate ocean cruiser/racer. Optional slip. Inboard Atomic 4, galley, head, sleeps 6. Roller furling headsail. Easy singlehand. All new: main, genoa, standing and running rigging, whisker pole, radio, mast antenna, charger, more. Racing setup. (415) 658-1826 or ewilliams924@yahoo.com.

30-FT CATALINA, 1987. San Francisco. \$28,000. Beautiful custom interior, Dutchman main flaking, roller furling, Universal diesel, Autohelm autopilot, dodger, self-tailing winches, refrigeration, hot pressure water, wheel helm, propane stove. (707) 258-0790 or (707) 287-8004.

30-FT CS, 1985. Vallejo Yacht Club. \$29,000. Top quality Canadian-built family cruiser. Well maintained, full sail inventory, new Pineapple jib, reliable V-P diesel, extremely roomy 6'2" headroom. See website for full details, working overseas - no time to sail! http://avocet.weebly.com. (530) 389-4308 or svavocet@gmail.com.

29-FT COLUMBIA, 1964. Tiburon. \$4,000. Brand new depth sounder. An absolute beauty. Photos available on visit. Photo: www.sbcglobal.net/jaspe

30-FT CORONADO, 1969. Rio Vista. \$12,500. Yanmar diesel, wheel, roller furling, dodger, radar, GPS chart plotter, new sails/rigging, bullet proof hull (I never really shot it, but it is blister free and channel marker proof). Call for details. (916) 837-2386 or sinner696@gmail.com.

ISLANDER 30 MK II, 1971. Moss Landing Harbor District. \$7,500. 4-cyl gas inboard (Palmer P60). Fiberglass hull w/teak trim. 3-burner alcohol stove/oven, BBQ. Depth/fishfinder, CB and VHF radio. Recent work: Sept '09 hauled out, tuned up, oil change, new head, replaced through hulls and zincs. Sails include spinnaker, 2 storm jibs, 100% & 130% genoa. Mahogany interior. 5 lifejackets, lots of extras. Sleeps 4 comfortably. Good solid boat. Ready to sail. Take over slip. (831) 915-6783 or (831) 659-1921 or drbradcase@sbcglobal.net.



30-FT SANTANA 3030PC, 1982. Ventura. \$27,000. Race or cruise. 2-cyl Yanmar 267hrs. New headliner/cabin sole/electrical panels. New rod rigging. Harken traveler/genoa leads. Harken roller furler, dodger, H/C pressure shower, CNG stove/oven. Full sail inventory. Too much to list. (805) 581-9220 or dnclaws@aol.com.

30-FT BABA CUTTER, 1981. Antofagasta, Chile. \$54,000. Roller furler, genoa, storm sails, drifter with sock, extensive ground tackle, Yanmar 30 with good spare inventory. Inflatable with 2hp Honda outboard. Delivery negotiable. (907) 299-1068 or jemkob@hotmail.com.



**Repair,
Restoration &
New Construction**
(510) 522-2705

Fred Andersen Boat & Woodworks

STARBOARD YACHT DELIVERIES

Over 50,000 sea miles • Pacific, Caribbean, Atlantic
USCG Master 100 GT STCW • Power & Sail

Rick Whiting • (415) 740-2924 • captain_rick@sbcglobal.net

30-FT ISLANDER BAHAMA, 1980. Brisbane Marina, Bay Area, CA. \$17,998. This is a great family cruising boat with a spacious interior and good sailing performance. Well maintained. Upgrades include: brand new mainsail, new toilet, stove & oven, built-in ice chest, Barbecue grill (portable), \$5,000 maintenance work in 2007. Power: Volvo Penta MD7A. Recent work on exhaust manifold. Runs very cool. Pressure water system, shore power with battery charger, wheel steering with autopilot, etc. Sails include new mainsail and storm jib. Currently docked at Brisbane Marina. (415) 812-7699 or christophersiow@gmail.com.



J/29, 1985. Seattle. \$18,500. Great race record, masthead rig, hydraulic backstay, B&G, stereo, rod rigging. Restored in 2002. Will take J/24 on trade. (253) 288-0117 or mandmstudios@q.com.

29-FT PEARSON TRITON, 1961. Sausalito, Clipper Marine. \$1,500. Snow-goose needs a new engine. Good sails, rigging. Needs interior work. Bottom has been cleaned regularly. (415) 457-5058 or bambart@comcast.net.



C&C 30 MK I, 1979. Alameda, CA. \$25,000. Kickback is in excellent condition! Shiny gelcoat, new or upgraded equipment (ports, lights, hatches, Lavac head, refinished cabin sole). <http://kickbacksailboat.weebly.com/>. (510) 377-5305 or jfoord@comcast.net.



30-FT CLIPPER MARINE, 1976. Redwood City. \$6,950/obo. Great condition, refurbished interior, sails like a dream. Furling jib, 15hp outboard engine, sleeps 4-6, V-berth cabin, new upholstery, oven/burners - email for list of other features. (408) 891-2224 or jmphill2@gmail.com.

29-FT ERICSON, 1973. Alameda, CA. \$Best offer. Good overall condition. New mainsail. New bottom paint. Call for other details. (925) 449-8584 or anjcos@sbcglobal.net.



29-FT PEARSON TRITON, 1966. Redwood City. \$7,000/obo. Turnkey-ready, well-maintained classic offshore cruiser. Raced on 7/17/2010, placing 2nd out of 7 Tritons in the annual BVBC Plastic Classic. Bought bigger boat, must sell. Photos on Craig's List. <http://sfbay.craigslist.org/boaf/>. (650) 780-9914 or chuckmillar@gmail.com.

32 TO 35 FEET

34-FT HUNTER, 1984. Sausalito, CA. \$24,900. If you can find a cruise-ready sailboat at this price, take it! This is a 34-ft sailboat that could leave for Mexico tomorrow. Just fill up the water and fuel and turn left after leaving the Golden Gate. Any takers? This is an excellent first time boat that is rigged for singlehanded and operates well under all conditions. I love this boat, but I am now the owner of another boat, so it is time to sell. This Hunter is priced to move. Photos and a detailed description of the boat can be found at: <http://witchdoctorsailboat.webs.com/>. Call (415) 497-6116 or medicrene@yahoo.com.

35-FT ALBERG, \$25,000. Beautiful and well maintained, ready for cruising. Loaded with gear. Radar, GPS, VHF, speed, depth, wind, 5 sails in good to excellent condition, hot-cold running water, Yanmar diesel, custom galley, frig/freezer and more. (510) 508-8384 or jhicks@exponent.com.

INTERNET FRAUD. Recently, we've been getting another tidal wave of reports of Internet scams, so we feel compelled to warn you once again about this unfortunate aspect of human nature. If somebody wants to buy your boat sight unseen, and suggests sending you a cashier's check for more than the asking price, trust your instincts. It is too good to be true. Usually they want you to cash the check and return the remainder to them for shipping costs. Then, much later, the bank informs you that the check was no good. We recommend that you don't even respond to the initial email inquiry. For more info on these cons, see: www.craigslist.com/about/scams.html Brave New World.

32-FT ENDEAVOR, 1981. Redwood City. \$21,000/obo. Bluewater cruiser, Yanmar 3GMD, 20hrs on rebuild, 5 sails, microwave, refrigerator, dual batteries, CQR25/35, autopilot, Aries vane sail system and much more. (831) 457-0539 ext: Linda.

34-FT SAN JUAN, 1984. \$30,000. Reduced for quick sale. Fast, comfortable blue water cruiser, excellent condition. 6' headroom, galley, sleeps six, rod rigging. Roller furling headsail, 150% genoa, main, working jib. 3GMD Yanmar, Achilles dinghy, large bimini. Original owner. (510) 420-8956 or nino@access-print.com.

35-FT YOUNG SUN, 1981. San Carlos, Mexico. \$74,500. Double ender bluewater cruiser, similar to Tayana 37, located in San Carlos, Mexico, ready to sail the world or cruise the Baja. German cabinet-maker owner for 19 years, beautiful teak interior, full cruise equipped, including: Spectra 80 watermaker, 2 GPS chartplotters, 2 VHF radios, Kenwood Ham radio with smart-tuner, 12 mile radar, Robertson autopilot, fully enclosed cockpit, Fleming selfsteering windvane, Radararch, 2 plow anchors, 200' chain, Adler Barbour refrigerator, Lavac vacuum head, Corian countertops in galley and head, solar power, 5 batteries, 6 fuel filters (2 systems). Call or email. (970) 259-5102 or mohrmonte@gmail.com.

34-FT TARTAN 34C - S&S DESIGN. 1974. Vallejo. \$38,500/obo. 27hp Yanmar 60 hrs orig. Profurl R/F-Fleming windvane, S&L electric windlass, 8 winches, single-handling set up, SS steering wheel, 2 dinghies. Owner motivated to sell. www.tartan34c.blogspot.com. (707) 644-2093 or marinsail3@yahoo.com.

35-FT BRISTOL 35.5, 1982. Santa Cruz, CA. \$35,000. Summer is in slip F-13. We're buying larger sailboat. Contact Bob at (831) 818-3438, (831) 438-1165 or piffspace@cs.com.



34-FT TIFFANY JAYNE, 1983. Richmond YC. \$39,500. Perfect for SF Bay and beyond. Beautiful, fast (PHRF132) and responsive. Delightful to sail. In the spirit of the Alerion for 1/3 the price. One owner. Superb condition. <http://sites.google.com/site/tiffanyjaneforsale/>. (510) 525-0279 or rpaccard@berkeley.edu.

32-FT PEARSON VANGUARD, 1964. Ventura. \$7,000/obo. GPS, radar, wind generator, 85w solar panel, depth, autopilot, propane range, A/B refig, strong diesel, dodger, bimini. Good rigging, sails. Needs painting, but completely sailable; used often. Med school forces sale. (805) 570-9883 or svdaedalus2005@yahoo.com.

ERICSON 35+, 1983. Emeryville, CA. \$51,500. Nicely maintained. Recent haul-out. Fairly new sails and hatches. Autohelm 6000 AP, diesel, fridge, furler, dodger, plotter, more. Please email me to get link to photos and more info. (925) 754-4560 or (925) 642-7600 or pmchin47@hotmail.com.



33-FT HOBIE, 1984. Alameda. \$12,000. Many extras, fast & fun. Great boat with many extras. Fixed keel version. This is a great shorthanded performance boat. Harken roller-furler, self-tacking jib, mainsail, lazy jacks, 6 other bags of sails, brand new bottom job. Custom cockpit well with custom outboard motor mount. Honda 4-stroke outboard - good condition, runs well. For more information, call or email, and to view a slideshow with more images, go to link: www.svendsens.com/hobie33/index.html. (415) 999-0509 or sean@svendsens.com.

32-FT BENETEAU 10R, 2007. Long Beach. \$125,000. Yanmar 20hp, Harken furler, main, jib, genoa, spinnaker, dodger, canvas, performance and comfort pacs, liferaft storage, multiple NKE electronics and repeaters, loaded, ready to go. Pictures: www.quivercharters.com. (310) 809-2263.

35-FT SCHOCK, 1988. Alameda, CA. \$25,000/obo. Most beautiful kickback, race ready, low hours, 150% genoa, 150% jib, 150% mainsail, Jew heave, and be ready to sail today!

32-FT WESTSAIL, 1973. Santa Cruz Harbor. \$40,000/obo. New engine and sails, really want to sell this summer. See website for full details and photos. <http://es.uccs.edu/~crowe/westsail32>. (831) 818-5550 or christierowe@gmail.com.



superwind.com



THIS COULD BE YOU...
Let the Glassy Classified business ads work for you.
Submit online at:
www.latitude38.com

Ted's Marine Refrigeration

EPA CERTIFIED SINCE '96
10 years experience, Mexico/US • New Systems, Design, Troubleshooting • Refit & Retrofit Icebox Construction • AC/DC Engine Drive, Holding Plates, Environmentally Friendly Refrigerants
a290anna@gmail.com • (408) 656-0549 • Available thru October

MARINE SURVEYOR

Sharpe Surveying & Consulting. SAMS Accredited Marine Surveyor.
Serving the San Francisco Bay and Delta.

RSharpe@SharpeSurveying.com • (510) 337-0706

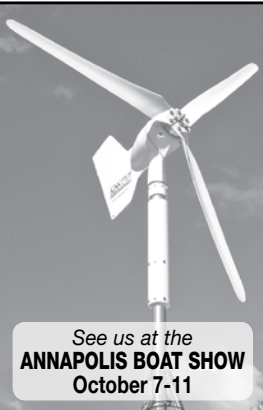

MORE ENERGY!

KEEP BATTERIES CHARGED!

- KISS wind generators
- Solar panels and MORE

USE BATTERIES EFFICIENTLY!

- LED lights
- Engel fridge/freezers
- Wonder Wash and more



See us at the
ANNAPOLIS BOAT SHOW
October 7-11

www.svhotwire.com

727.943.0424

RODGERS & ASSOCIATES

Certified

Marine Surveyors

As appointed by Boat US Insurance Services
and Institute of London Underwriters
ASA - NAMS - LLOYDS



established
1978

Tel: 831-475-4468

vrodgers@rogersandassociates.com

www.rogersandassociates.com

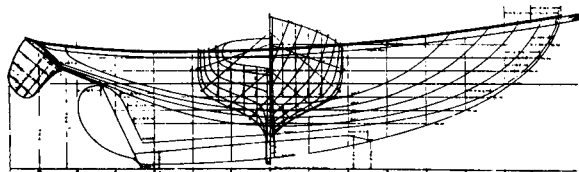

MAKELA BOATWORKS

Family owned since 1948

Wooden Boat Building • Repair and Restoration

19280 South Harbor Drive • Fort Bragg, CA 95437

(707) 964-3963

email: howard@makelaboatworks.com • www.Makelaboatworks.com

Mathiesen Marine

For all of your electronics and electrical needs

Sales & Installation of all major brands
of marine electronics



PC & Mac based
Navigation Systems

Electrical system
Troubleshooting & Repair

Corrosion issues, Inverters, Battery banks



3300 Powell Street, Emeryville

(510) 350-6622 www.MathiesenMarine.com



34-FT C&C, 1979. South Beach Harbor. \$29,500. Great sailboat in great shape. 90, 110, 150 jibs, flasher and main, YQ20M Yanmar diesel, 10-ft West Marine inflatable dinghy with 8hp Tohatsu. Complete survey on June 4, all items professionally repaired. She is an awesome lady and will make a great addition to your family. (207) 650-6855 or herbert.gillman@gmail.com



HUNTER 33.5, 1992. Marina Bay, Richmond. \$45,000. 27hp Yanmar. Very clean. Coast Guard register bottom job - 11/09. (707) 331-7491 or georgefields7@comcast.net.



33-FT RANGER, 1975. Santa Cruz. \$22,750. Great boat. New topside, paint, nonskid and refinished teak. Tall rig, PHRF 150, newly rebuilt 1GM10 Yanmar diesel, dripless stuffing box, dodger, new Raymarine GPS A50 chartplotter, new cushions, foredeck traveler for jib, 90, 150 and storm jibs, 3 reefs laid in, 8 winches, davits, reinforced stern, tons of extras, fast and comfortable. One year lower harbor slip available. Hawaii veteran. www.elkhornyc.com/Tequila. (408) 828-0534.

35-FT SANTANA, 1979. Berkeley Marina. \$8,000/obo. Great for cruising or racing in the Bay. Comes with multiple headsails, mainsails, and a spinnaker, plus sheets, guys, etc. Equipped with multiple dual-speed winches, compasses, VHF radio, stove/oven, two sinks, and head. New mast and keel. 2-cylinder Volvo 15hp diesel engine with new high-output alternator. Needs some work on electrical system and interior floorboards. Berthed at O-dock in Berkeley Marina. Price negotiable. Call to schedule a viewing. (510) 393-4074 or lorydod@gmail.com.



32-FT HANS CHRISTIAN, 1980. Sacramento Delta location. Excellent condition, original owner, engine 525 hours. Truly see to appreciate. (510) 527-5036 or davidanderson787@comcast.net.

CATALINA 320, 1998. Emery Cove Marina. Excellent condition, original owner, engine 525 hours. Truly see to appreciate. (510) 527-5036 or davidanderson787@comcast.net.



33-FT HANS CHRISTIAN, 1980. San Diego. \$119,000. Change of plans! Fully refitted for S. Pacific voyage. New Yanmar, electronics, watermaker, sails, rigging, batteries, solar, canvas, dinghy and spares. Loads of cruising gear. Ready to go. (619) 319-0136.



34-FT J/105, 1994. San Francisco. \$82,500. Hull #83, pre-scrimp boat is for sale. Lightly used. Minimum class weight, wheel package, excellent condition. (650) 380-1583 or josephandresen@mac.com.



32-FT ARIES, 1978. Finco Maine, Santa Ana, CA. \$15,000. Lien sale, Aries 32 AKA RoughWater 33 traditional double ender. 4 cyl Westerbeke. This is a serious offshore vessel, at 10 tons, a great deal. <http://fincofab.com>. (714) 973-2878, (714) 425-9788 or finco@sbcglobal.net.

OFFSHORE PASSAGEMAKING INSTRUCTION IN THE SOUTH PACIFIC

John & Amanda Neal are dedicated to providing hands-on, documented instruction aboard their Hallberg-Rassy 46 *Mahina Tiare III*, drawing on their combined 502,000 miles and 66 years of experience.

www.mahina.com • (360) 378-6131

Going Somewhere? **Mexico • Caribbean • South Pacific**

Stop by our office and take a bundle of *Latitude 38* along with you.

We promise you'll be a hero for sharing them with other cruisers!

Latitude 38 • 15 Locust Ave • Mill Valley, CA • (415) 383-8200 • Open M-F 9-5

36 TO 39 FEET



38-FT CATALINA 380, 1998. Alameda. \$89,500/obo. Exceptionally clean inside and out. Well equipped. Professionally maintained. New bottom 01/10. Priced for quick sale. Call: (209) 612-8128.

38-FT HUGHES, 1970. Monterey, CA. \$21,000/make offer. Canadian built S&S design. Sound hull, low hours on nearly new diesel engine. Sails nicely, needs TLC & newer/upgraded equipment. (831) 915-4984 or coffina@sbcglobal.net.



38-FT HANS CHRISTIAN MK II, 1985. Savannah, Georgia. \$80,000 motivated. PRICE LOWERED!! New epoxy glass hull, shaft, MaxProp, cutlass and stuffing box, 300' of 3/8 HT chain primary, 100' 3/8 HT on 300' rode secondary ground tackle from Svendsen's Aug. '09, new keel-cooled Frigoboat unit, new Lectra-Scan. Raymarine radar and chartplotter. Two mains-one full batten, 130 jib, staysail, storm sail, inner forestay blooper sail. Ready for Med or Fiji. (404) 354-3855 or (770) 710-7079 or joe_millsaps@yahoo.com.

36-FT BENETEAU 361, 2002. SF Marina West Basin. \$118,000. Bristol, loaded, custom, all electronics, recent haul-out and bottom paint + coveted SF Marina Berth. (415) 771-0741 or Bob@TandlerSF.com.

37-FT TARTAN, 1976. Maryland. \$34,000. Bahamas, Caribbean? Budget cruiser, go now. Good old boat. New Harken furler, radar, SSB, solar, '08 FB main, windlass, AP, frig, inverter. Centerboard missing, sweet sailing S&S design. If not now, when? (301) 974-2620 or tw33432@yahoo.com.

36-FT UNION - CUTTER RIGGED, 1986. Oregon. \$110,000. Beautiful documented sailboat w/large salon and separate shower. New Isuzu diesel engine ('03 - 200 hrs). Full cockpit enclosure. Great liveaboard. Consider partial trade for West Coast property/condo. See more at www.ablboats.com/details.php?id=81027. suzieandpete@msn.com.



39-FT CAL, 1971. Oceanside, San Diego. \$35,000. New professional racing bottom, just splashed Nov 5, '09. Great racing inventory, new 3/4 oz. Ullman spinnaker, double spreader tall rig. Gas engine. Good shape and fast. (949) 280-6220 or granahan@cox.net.

36-FT COLUMBIA, 1968. Sausalito. \$19,500. Great shape, very clean. New standing rigging, new head (and plumbing), VHF, autopilot, Zodiac, many extras. Perfect for Bay sailing and/or cheap liveboard. See photos at: <http://picasaweb.google.com/104111962701917547080/Nativa#>. Contact (415) 250-3273 or rogerwilliams4@gmail.com.

36-FT CATALINA, 1983. Alameda. \$39,950. New dodger, sail, winch, pedestal covers, standing, running rigging, topping lift, fuel tank, ss shaft, heat exchanger, radar, GPS, interior cushions, head, stern seats, voltage regulator, furler, jib. Bimini, inverter, Autohelm, 4 batteries, pressurized water, Link battery monitor, 100-amp rebuilt alternator, VHF, cockpit cushions, 12-120V refrigerator, Universal diesel. Sleeps 7, stereo, reefing lines to cockpit, solar vents, head with shower, refinished non skids, teak and holly sole. Boat almost totally refit. Excellent condition. John (510) 731-4259 or jandersonwj@sbcglobal.net.



38-FT ALAJUELA, 1976. Sequim, Washington. \$129,000. Well maintained and equipped 38-ft FRP cutter. Stoutly built for offshore cruising. Many improvements including new engine 2005. Go to blogspot for full details and photos. <http://alajuella38.blogspot.com>. (360) 683-8662 or svselah@yahoo.com.

36-FT HUNTER 356, 2003. Alameda. \$92,900. Beautiful boat. Very spacious interior. New bottom paint. Save thousands over buying through a brokerage. See all details and photos on the listed web page. <http://web.mac.com/laynegalloway>. (801) 419-4100 or laynegalloway@msn.com.



39-FT LANDFALL, 1975. Alameda. \$25,000/obo. Bluewater, cruising vet. Excellent opportunity to own one of the best designed cruising boats. Has radar, good sails, new mast/rigging. Boat is in need of some engine work and woodwork. Call Mark. Trade for Cessna 182. (510) 501-5046 or mkrajcar1@gmail.com.

36-FT BENETEAU 36.7, 2005. Port Angeles, WA. \$140,000/obo. Beautiful 36.7, all cruising amenities. Shows as new, see pics and details at website. <http://beneteau367forsale.com>. (360) 452-1110, (360) 460-1014 or bill@cpfiber.com. (54 West Misty Lane, Port Angeles, WA 98362.)



36-FT MUMM RACING SLOOP, 1993. Seattle. \$47,990. Panama Red. Set up for competitive racing, spirited cruising or day sailing. Accommodates eight. 18hp Yanmar. 21 bags of Quantum, Sobstad and Nuclear. Five kites and headsails for every condition. Fitted with telescopic bowsprit for asym kite. Fast bottom. Motivated two boat owner!!! (360) 981-3758 or robh@harboret.com.

37-FT CREALOCK CUTTER, 1980. Monterey. \$45,000. Ballenger tabernacled mast. New Yanmar w/saildrive, radar, GPS, easy access to all systems, 70gal diesel, 3 watertight bulkheads. Not in yacht condition, needs finish work. Great little sailing ship. Price firm. ddatpbio@gmail.com.

37-FT HUNTER, 1982. Hidden Harbor, Rio Vista. \$29,900. Cutter rigged, Cherubini designed, Yanmar diesel, dodger, autopilot, lines aft, cruise vet, Achilles dinghy with dinghy tow system, 18hp Johnson. Hauled 5/09, new rigging 6/09. www.mysailboatformsale.com. (775) 721-5221 or wh2ojake@yahoo.com.

36-FT ISLANDER, 1979. North Bay. \$38,500. Clean, well maintained and great Bay boat. New jib and good sails. Complete bottom job with barrier coat in 2008. Westerbeke 4-cylinder diesel, low hours, runs excellent. Includes hard bottom Zodiac with outboard. (707) 664-0120.



38-FT KETTENBURG, 1956. 3 Available. "Nice boat!", "Beautiful boat!", "Gorgeous boat!" heard many times from other boaters during every sail. Enjoy character, admiration, and fantastic sailing while sustaining the heritage. Details at: www.sailk38.com. (916) 847-9064 or steve@paradigmpilgrim.com.

CATALINA 36 MK II, 1995. Alameda. \$85,000. Excellent condition, includes windlass, hot/cold pressurized water, inverter, VHF, electronics, low engine hours, 15 horse Johnson motor and Zodiac inflatable. (510) 523-4081 or roystark@aol.com.



38-FT HUNTER 380, 2001. San Diego, CA. \$119,000. Well loved Hunter 380 for sale by owner. Lots of equipment and extras... ready to go! Go to her website for pics and full specs, or call us and we will fax or email them to you. www.hunter380.com. (909) 721-2095, (909) 721-0891 or dcafr2@yahoo.com.



38-FT VINDO, 1981. San Pedro. \$82,000. Swedish bluewater cruiser, full electronics, Selden mast, heavy rig, dodger, fridge, etc. Ready for Mexico and beyond. (951) 285-7934 or barbxbarb@yahoo.com.



For the best - and most exposure - of your classified ad...

submit your ad safely online at: www.latitude38.com.

Clarry Idea!

Your ad will be posted online within two business days, appear in the next issue of the magazine, and remain online until the following issue is released.

magnetic signal flags!

pirate poetry!

check it out!

WWW.OCEANPOETRYDESIGNS.COM



WHILE YOU'RE AWAY YOUR ANIMALS CAN PLAY

And you can know they are warm, safe, and being looked after.

KITTY COTTAGE

Insured through PSA, LLC.

DOGGIEVENTURE

Cageless cat boarding

C-and-S-California.com

A doggie daycare on the go!

Bow Yoga

YOGA FOR SAILORS ON THE WATERFRONT

Gentle yoga class at Oakland YC Saturdays 8-9 am starting Sept. 4. Beginners welcome! Donation-based; all proceeds benefit Alameda Food Bank. See www.bowyoga.com. yogaforu2009@gmail.com, (415) 785-4530, (510) 333-8846

We are always
looking out for you!

American Yacht Insurance for boats over
26 feet. We provide cover for any flag
registration or
navigation.



USA09037 www.pghh.de

PANTAENIUS
American Yacht Insurance

Germany • Great Britain • Monaco
Denmark • Austria • Spain • Croatia
Sweden • USA*

500 Mamaroneck Avenue Suite 318
Harrison, NY 10528
Phone (914) 381-2066

Newport Shipyard
One Washington Street
Newport, RI 02840
Phone (401) 619-1499

www.pantaenius.com

*Pantaenius America Ltd. is a licensed insurance agent licensed
in all 50 states. It is an independent corporation incorporated
under the laws of New York and is a separate and distinct entity
from any entity of the Pantaenius Group.

MARINE ENGINE CO.

WESTERBEKE

Universal
DIESEL MARINE ENGINES

BETA MARINE

LICENSED DEALER FOR ABOVE

PERKINS • YANMAR • ATOMIC 4 • VOLVO

CALL NOW FOR LOW ENGINE QUOTES

- Engine Sales, Service and Parts
- Engine Repowering and Rebuilding
- Complete Marine Engine Service

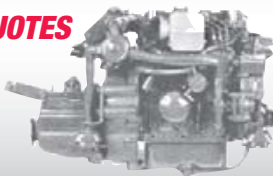

(415) 332-0455

DF DIESEL FUEL FILTERING



Purify Diesel Fuel & Flush Tanks

Process scrubs, polishes, removes algae, dirt, sludge, rust, water, and
foreign particles from diesel fuel. Includes internal tank washdown.
Save your injectors, costly engine repair and down time.

Since 1989. Fully insured. Your berth or boat yard.

(510) 521-6797 Fax: (510) 521-3309

www.dieselfuelfilterings.com



BottomSiders
2305 Bay Avenue
Hoquiam, WA 98550

Save Your Aft!

Using one of our 1900+ patterns or your
own pattern, let our craftsmen create a
comfortable, durable, and stylish set of
all-weather cushions for your cockpit.
Find your custom, closed cell foam
cushions at www.bottomsiders.com!

BottomSiders

Call Toll Free: (800) 438-0633
cushions@bottomsiders.com
Fax: 360-533-4474

40 TO 50 FEET



47-FT CUSTOM STEEL BOAT, 1990.
Lankawai, Thailand. \$120,000. The 'Pearl
Hunter' is for sale. This rebuilt, custom
steel schooner has storage for more than
30 surfboards, an ice box with a capacity
of 1000lbs, watermaker, custom hatches,
stainless steel railings, custom dodger,
watertight bulkhead, brand new stove
and interior. Ready to sail to the Mentawai
Islands or sail around the world. The hull
has been almost completely rebuilt, water
tanks rebuilt, hydraulic fishing reel. Recent
survey and haul out. (808) 203-7262 or
kriit@hotmail.com.



43-FT BALTIC, 1987. Sausalito. \$200,000.
A truly beautiful vessel, one of only 47 in
the world. Fast, responsive, fun to sail,
daysailing or extended ocean passage.
Available with slip. May consider trade for
business or real estate. (831) 684-2457 or
tglass@cdv-enterprises.com.



42-FT FREYA, 1983. Guaymas, Mexico.
\$85,000. A little longer, wider and stronger
with the same Freya pedigree. Round
bilge steel version built in 1983 by Ger-
man professional with inside finished in
mahogany. Email me for details/pics.
trevand1@yahoo.ca.

50-FT FD-12, 1981. Mexico. Unsink-
able 50-ft cutter, AK/Mexico/SoPac vet.
Superb galley in pilothouse: generous
counter space, good daylight and view.
Berths for 5-6 in 2 staterooms forward
and master stateroom aft (privacy for
parents w/children or guests). [www.sv-
daydreamer.com](http://www.sv-
daydreamer.com) or (928) 717-8812.



NAUTICAT 44, 1983. Blaine, WA.
\$165,000 - REDUCED. Perfect Pacific
Northwest/bluewater cruiser. Berthed
in gorgeous San Juan/Canadian Gulf
Island cruising grounds. Cutter-rigged
ketch. Inside/outside steering. Queen
walk-around. Swim platform. Click on link
for pictures, specs, contact information.
<http://SailingSojourner.blogspot.com>.

42-FT WOOD KETCH, 1969. Moss Land-
ing. \$19,950. Ketch has newer Perkins
diesel. Roomy interior makes for good
liveaboard. Vacuflush toilet, new AC/DC
panels, new upholstery. Full size bed &
double sink, 3-burner propane stove,
cozy fireplace. Call for more info. (831)
760-2558.

44-FT KELLY PETERSON, 1975. St
Marys, Georgia. \$80,000 best. Total
refit in 2005. New rigging, sails, Ray-
marine E Series integrated nav system/
autopilot/radar. RIB and motor. Liferaft.
Norcold cold machine, Force Ten stove/
oven, much more. [www.liveirishmusic.
com/Sailboat.htm](http://www.liveirishmusic.
com/Sailboat.htm). (619) 253-2474 or
emerysandiego@aol.com.

46-FT PETERSON/FORMOSA, 1979.
West Marin. \$90,000. Center cockpit cut-
ter. Rebuilt (850 hrs.) 80hp Ford Lehman.
Newer rigging, chain plates, wiring and
fuel tanks. Monitor vane, solar panels,
wind gen, watermaker, SSB, GPS chart-
plotter, radar, electric windlass. (415)
663-9225.

47-FT CUSTOM FIBERGLASS CUTTER.
2004. Coos Bay, OR. \$499,000. Price
reduced. Blue water high latitude cruising
sailboat, two helms, one enclosed, sleeps
six, premium equipment, electronics,
85HP diesel, 4.2KW generator, work-
shop, 200+ fuel and water, refrigeration,
washing machine, insulated. Pictures:
www.hyssop.com/boat. (541) 888-5688.

43-FT ROBERTS MAURITIUS, 1989.
Morro Bay. \$65,000. Fiberglass, center
cockpit, ketch with in-mast furling. Walk-
thru to aft cabin with vanity and head.
Diesel genset, a/c, watermaker, washer/
dryer. Electric windlass, radar and autopilot.
Consider trade for smaller boat. (805)
674-0678 or captij@charter.net.



Sealand VacuFlush Special

Installed to Your Holding Tank
■ \$2,400 ■ (510) 205-1695 ■ Call Barry
Certified VacuFlush Dealer

Latitude 38 eBooks

FREE ★ AVAILABLE WORLDWIDE ★

www.latitude38.com/ebooks.html



40-FT PASSPORT, 1986. Monterey. \$148,500. Sail away on a proven Perry design offshore equipped performance cruiser/liveaboard. Beautiful teak interior, preferred layout, exceptional galley, spacious cockpit. Low hour Perkins, full electronics, watermaker, davits, dodger/bimini, awnings. (831) 277-2762 or rmorepp@yahoo.com.



40-FT CATALINA 400, 1997. Saint Francis Marina, San Francisco. \$120,000. Brand new sails, new touch screen GPS, new Harken batt car, new halyard, new autopilot 6000 below deck and transferable temporary San Francisco slip. It's a beauty inside and out and has been maintained well! VERY seaworthy, made the Baja Ha-Ha trip and back 2009. Needs a new owner that will give her lots of love! (510) 830-9300 or Lilliaslemmons@yahoo.com.

40-FT CHALLENGER SLOOP, 1974. Emeryville, CA. \$55,000 obo. Great offshore cruiser/liveaboard. Radar, GPS, autopilot, new roller furling and mainsail. Two private staterooms, 1 head, Norcold standup reefer/freezer, 55hp Perkins. Full dodger with canvas enclosure, dinghy on davits. (530) 228-1827 or lorenchristopher@sbcglobal.net.



44-FT CATALINA MORGAN 440, 2005. Napa. \$220,000. In great condition. Completely set up for cruising and has sailed to Tahiti and back. Roller furling, inner forestay, autopilot, radar, chartplotter, dodger, 120 Vac inverter, 600 AH battery bank with quick charge system, 75hp diesel engine, VHF, stereo, 2 zone cabin HVAC, refrigerator and freezer, watermaker, dinghy davits, 4 sails including asymmetrical spinnaker. Call Denny for more details. (707) 486-0412.

45-FT DOWNEASTER CC, 1980. La Paz, Mexico. \$Best offer. This California-built boat was refitted in 2004. Our plans have changed and we will make this an excellent deal for new owner. Can be seen at website. www.mazmarine.com. (941) 204-3271 or kruz2004@aol.com.

J/41, 1985. Spindrift Marina, Isleton. \$29,000. Set up to cruise or race, V-berth, propane stove, teak interior, refrigerator, Harken furler, 4 kw radar, 2 autopilots. Has been to Canada and 2 years in Mexico. (530) 432-1234, (530) 320-4762 or mightywings@sbcglobal.net.



40-FT PETERSON, 1980. Sunroad, San Diego. \$49,000. Doug Peterson design offshore blue water racer/cruiser. We bought the boat in 2003 in San Diego and sailed her to France. After 1 year of refit and several regattas in the Mediterranean, we came back across the Atlantic (2007), making the crossing in 13 days. She has an open plan design with space to sleep 8-10 crew. Ideal for someone looking to do some racing, but also with serious offshore capability. (619) 573-3525 or mark.richards@gmail.com.



CATALINA 42 MK II, 2000. Kemah, TX. \$174,400. Proven, turnkey luxurious liveaboard/cruiser. *Ten Ten* is a three-cabin model which was professionally optimized for extensive liveaboard/cruising. The port aft stateroom is a nav area/office/communications room. Includes watermaker, generator, A/C, dinghy/15hp OB/davits, solar, SSB, washer/dryer, additional freezer, Tempur-Pedic mattress, vacu-flush head, asymmetrical spinnaker, storm sails, and much more. Owners sailed from SF to TX via Panama Canal 2005-2009. www.sailblogs.com/member/svtenten/. (530) 514-0356, (530) 514-2098 or cynthia@canterburycabins.com.

CATALINA 42 MK I. 3-cabin Pullman, 1989. Ventura, CA. \$109,500. Beautiful Catalina 42 w/3 cabins. Extensive sail inventory. Tons of extras and upgrades! Ready for cruising! <http://catalina42for-sale.blogspot.com/>. (805) 637-5140, (805) 390-4867 or sailingbeauty2@yahoo.com.



435 BENETEAU, 1985. Marina del Rey. \$129,000. A rare pedigree French export. Open checkbook refit and maintenance. Huge equipment list. Tall rig. 12 ST Lewmar's, Harken, low-time Perkins, all B&G's w/pilot, custom panel, Furuno radar/GPS. Perfect teak decks. Huge aft stateroom. Navtec and Quantum, etc. Swan looks-Frers speed. Sistership in book "World's Best Sailboats". Timeless beauty. Turnkey. (310) 666-4546 or (310) 550-0742 or berniefried@gmail.com.

44-FT ROBERTS 44D STEEL HULL sailboat, 2000. Grand Marina, Alameda. \$80,000. Avon 4-man liferaft, Harken roller furling, jib and staysail. Electric windlass, stainless freezer/reefer, diesel generator. Shortwave radio and GPS, Force 10 stove. Center cockpit, cutter rig. New canvas dodger. EPIRB, Electra San, watermaker, 20gal water heater. 33 Yanmar diesel engine. (510) 233-3224 or (209) 358-4537 or williams9910@att.net.



HERRESHOFF CARIBBEAN 50, 1978. Napa Marine. \$199,500. 14.5' beam, 6' draft, Perkins 6-354, radar/AP/SSB-Ham, VHF, Probe, 6-person raft, spares, tools, dinghy/motor. Fresh interior refinish. Not a fire sale. Serious inquiries only. www.sailboatlistings.com. (707) 834-4798.



40-FT PETERSON IOR, 1979. Singlar Marina, Guaymas, Mexico. \$90,000. Alum. hull, Pathfinder 50, watermaker, electric windlass, 66 Bruce, Profurl, hard vang, spinnaker/whisker poles, full batten 3-reef main, strong track, 5 headsails, boom brake, winches-2 3-speed, 5 self tailing, radar, GPS, depth sounder, autopilot, windvane, 2 solar panels, 100 amp alternator, 8 AGM, 2 inverters, stove/oven, Lavac head, refrigerator-7.2 cubic ft. (435) 513-1556 or s.blues1@yahoo.com.



GULFSTAR 43 MK II. Center cockpit ketch, 1979. San Diego Pier 32. \$89,000. Much loved ketch, easily handled by two. Great liveaboard with 2 cabin, 2 head layout, great galley, Perkins 4-108. Continually maintained. Ready for cruising, just add electronics and go. See detailed specifications and photos at www.svDreamKetcher.com. (805) 558-9969 or skipper@svDreamKetcher.com.

41-FT MORGAN CLASSIC MODEL. 1991. San Carlos, Mexico. \$98,000. Primo condition. Equipped and ready to cruise. Center cockpit, great liveaboard, must see to appreciate roominess. Recent survey. See blog for equipment list and current photos. <http://sailboat-vagari.blogspot.com>. (520) 825-7551 or stanstreb@gmail.com.



40-FT FORMOSA KETCH, 1975. Marina Bay, Richmond. \$25,000. 40ft O.A., 34ft O.D. Glass hull. Partially rebuilt 2001-present. Replaced items with new includes engine, masts, electrical, etc. Excellent liveaboard. Complete inventory. (415) 302-9944 or mpayne@camarin.org.

51 FEET & OVER



65-FT FREEDOM, 1981. Berkeley Marina, L. Dock. \$65,000. Fiberglass/balsa core, 200hp Volvo Penta diesel, about 100hr. 3-carbonfiber mast, sail plan not finished, bottom kept up - in good shape, boat needs work. This is one big boat! 18-ft beam, lots of headroom. (510) 701-5846 or ronwmail@yahoo.com.

SMALL AD, SMALL PRICES • RIGGING ONLY

Standing and running rigging, life lines, furling gear, winches, line, windlasses, travelers, wire and terminals, blocks, vangs, and much more.

~ ~ ~ Problem solving and discount mail order are our specialties ~ ~ ~
www.riggingonly.com • (508) 992-0434 • email: sail@riggingonly.com

Latitude 38 Crew Party

Come to our Mexico-Only Crew List Party and Baja Ha-Ha Reunion, Wednesday, September 8, at Encinal YC in Alameda, 6-9 pm. Free for 2010 Baja Ha-Ha skippers and first mates; \$7 for everyone else. See www.latitude38.com for details.



PROFESSIONAL DELIVERY CAPTAINS

San Diego based, USCG Master 100 GT. Sail and power. ASA-certified instructional deliveries. Pacific Mexico and Baja Bash specialists. davidhbrotherton@yahoo.com • www.boatdeliverycaptain.org • (619) 913-7834 •

COMPLETE MARINE WOODWORK

Design / Restoration • Expert European Craftsmanship • Interior / Exterior Repairs / Maintenance • Marine Windows & Frame Replacement Wood & Dry Rot Repairs • Varnish Work • Marine Painting
References Available • Reasonable Rates • Call (415) 331-6718

Boomkicker® BOOM SUPPORTS

BOOM TRACK FITTING NOW STANDARD - SAME PRICE, GREAT VALUE!

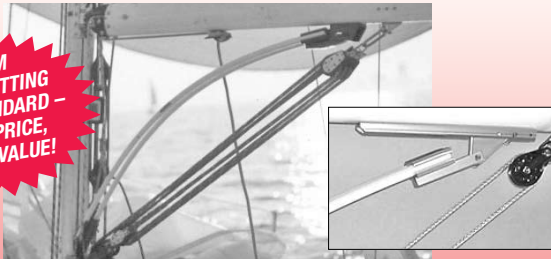

Join thousands of happy customers. For boats 14 to 38 feet.

www.boomkicker.com
(800) 437-7654 • (708) 482-8801

ATLANTIC 57 CATAMARAN™



THE ORIGINAL PILOTHOUSE CATAMARAN

- Designed for easy shorthanded cruising
- Spectacular windward performance
- Cored epoxy/glass/carbon construction

CHRIS WHITE DESIGNS
TEL: 508-636-6111
www.chriswhitedesigns.com

QUALITY CUSTOM CRUISING SAILS FOR LESS!

LEE SAILS

NOW 10% OFF

**MAINSAILS
MIZZENS
STAYSAILS
HEADSAILS
SPINNAKERS
SAILCOVERS
STRONGTRACK**

(510) 521-2353 • leesailsnc@yahoo.com

2021 Alaska Packer Pl. • Grand Marina • Alameda, CA 94501

SAILMAKER TO THE WORLD SINCE 1947

Marine Diesel Specialists AT YOUR SLIP!



30 years experience • Universal/Westerbeke dealers
Repairs/Tune-ups all models • Engine Surveys, Instruction

BAY MARINE DIESEL 510-435-8870

baymarinediesel@comcast.net

CLASSIC BOATS

25-FT CHEOY LEE VERTUE, 1956. Alameda. \$12,500. #138, Laurent Giles' masterpiece, 9000 lbs. of solid craftsmanship. Copper riveted teak planking. Newer epoxy/plywood deck. Ready2sail! Low hour 12hp Westerbeke diesel. Vertue info at website. <http://vertueowners.org.uk>. (707) 832-6223 or casejames@fastmail.fm.



30-FT AUGNAUGHT, 1995. Moss Landing, CA. \$23,500. Monohull monotony got you down? Looking for something a little faster? Want to fly across the Bay with your hair on fire screaming yeeehaaaaah! Zoom just may be the medicine you need, and as a trailerable boat you will have access to many fresh water venues as well. The current owner needs to slow down for a while and wants it sold now! Hence the low price. This boat is ready to go now. Reduced from \$33,500 to \$23,500. (831) 247-7939 or hawknest1@prodigy.net.



17-FT CHRIS CRAFT SPORTSMAN. 1959, Clearlake, California. \$7,000. Runs well, looks good, total of 428 hours since new. Out running last month, always on Clear Lake. Stored inside until 2004, engine Hercules 6, picture taken this July. (707) 994-9365 or ndmcghee@gmail.com.

MULTIHULLS



46-FT DOLPHIN 460, 2006. Puerto Rico. \$519,000. Beautiful, clean, fast and already in the Caribbean. See details for *Muse* at website. Will consider trade for well maintained late model monohull in 40 ft. range. www.yachtworld.com/multihull/index.html. Email p_brown@comcast.net.

34-FT GEMINI 105M HULL 681, 2000. Ventura Harbor. \$123,000. Will consider offers.. 27hp Westerbeke diesel (new, 0 hrs.), 18" draft. Refrigerator/freezer, runs on A/C or propane, Raymarine autopilot, depth sounder, wind direction, knot meter tri-data. Standard Horizon VHF, 16 mile Furuno radar. Tri lens radar reflector. Garmin 192C chartplotter. Four 6-volt (golf cart) battery house bank (new 9/09), starting battery (new 10-09), Link 20 dual battery bank monitor, Xantrex battery bank combiner, Xantrex 20-amp smart battery charger. 2 fuel filters with 4-way valve, compass, Garhauer davits. New bottom paint May 2010. Maxwell 1200 watt windlass. 2 anchors-primary anchor is 35# Delta. Sails: asymmetric spinnaker, main, storm, jib and genoa. Tony Morelli designed StackPack. Much more. (805) 217-3939 or dick.mahoney@gmail.com.



40-FT SEARUNNER, 1979. Blaine, WA. \$80,000. Among best in class. Well designed, constructed, maintained, equipped. Veteran of five-year cruise 2001-2006. Refit and survey 2007. Sleeps six, 15 sails, 30hp diesel, radar, autopilot, windvane, watermaker, SSB radio, solar panels, wind gen, liferaft, new paint. Awesome cruising boat. See more at <http://searunner40seafire.wordpress.com/>. (360) 756-5004 or svseafire@yahoo.com.

50-FT PRIVILEGE 495, 2002. San Francisco/San Diego. \$680,000. French built Privilege 495. Great condition, ready to sail. In San Francisco Bay in September and in San Diego in October. See more at <http://catamarankertidou.blogspot.com>. (619) 208-9985 or thierrybonnefille@yahoo.fr.

MULTIHULL YACHT DESIGNER • MARINE SURVEYOR

John R. Marples, CMS • Certified, National Association of Marine Surveyors
Multihull Design Specialist • Pleasure and Commercial
Design office for Jim Brown Searunner, Seaclipper & Constant Camber Multihulls
www.searunner.com • (707) 343-1378 • marplesmarine@comcast.net

Need Crew? Latitude 38 Crew List A Boat to Crew on?

Visit our website and sign up as Skipper or Crew • It's Free

Find out about our next Crew Party: Wed., Sept. 8, at Encinal Yacht Club
More info: www.latitude38.com/crewlist/Crew.html or call (415) 383-8200

34-FT GEMINI 105M, 2000. Pt. Richmond. \$119,500. Hull #660. World's most popular catamaran, comfortable cruise equipped with 3 headsails, traveler, davits, and more. 14' beam fits standard berths. Send email for list of equipment. Will consider trade down. (510) 367-0500 or jadawallis@hotmail.com.

42-FT CROSS, 1983. Rio Vista. \$35,000. Boat is very sound structurally and well-built. Needs hauling out, top and bottom paint, interior finish work. Extras: sails, solar panels, fiberglass materials, rigging, and much, much more. Serious ONLY please! (925) 584-7677 or tripleripple@earthlink.net.



37-FT SEARUNNER TRI, 1973. Eureka. \$35,000. Profurl, windlass, autopilot, 2 depthsounders, GPS, cutter rig, extras. http://ter2000sail@yahoo.com.

POWER & HOUSEBOATS

43.5-FT LABELLE TRAWLER. Sausalito. \$145,000/obo. 360 view side tie adjacent to open space. Diesels w/500 hours, 7.5 Onan. Roomy glass-enclosed sundeck. Full canvas. X-large custom galley. Master has walkaround queen, tub + private guest stateroom with large bed, head. Outstanding workmanship/condition. May finance, rent or trade. (415) 999-5626.

28-FT PROTECTOR, 2001. Lake Tahoe. Beautiful center console Protector, 99% fresh water use. Two 225hp Yamahas, under 400 hours. Teak sole. Rear seat, GPS/chartplotter, VHF. Excellent condition and very fast. (530) 583-4000 or (530) 518-8500 or GD@DorlandProperties.com.



65-FT WOOD CLASSIC, 1939. Heavy built ex-trawler. GMC 12V-71, 21-kw generator. Full electronics. Lots of equipment. Ready to go. Would make great conversion. Will consider any reasonable offer. More pics/details: (707) 964-5423 or ancona@mcn.org.

54-FT SAGAR 16 METER BARGE, 2002. Central France. \$290,000. Custom built for all navigable waterways. 2 Brms, 2 bath. Complete inventory for comfortable cruising. See website for photos and complete inventory. Sagar has a two-year waiting list for new build. Owner financing. http://web.me.com/cbroussard/Acadia/Welcom.html. pat1083@sbcglobal.net.

36-FT HOLIDAY MANSION, 1980. Emeryville Marina, Emeryville, CA. \$24,500. Covered berth 1980-2008. Single V-8 I/O 1995 Volvo Penta/Kodiak. Engine serviced 7/10 (new water pump). New fresh water pump, stern thrusters. Electro-scan installed 11/08. Stainless steel water tanks-80 gal. Hauled/surveyed/bottom paint 11/08. Direct TV HD satellite dish with 19" HD TV. Two leather recliners. Great liveaboard. Free cable. Free WiFi. Excellent condition. (206) 303-8878.

PARTNERSHIPS



CATALINA 30 SHARE. Only one share left. Sausalito. \$270/month. Docked in the best marina in the Bay, w/parking just steps to boat, 5 minutes to Bay sailing. Many upgrades: wheel/diesel/newer performance mast/spars, furling, MaxProp, GPS, spinnaker, new cushions. Share \$270 month for 7 days max/month. Photo is sistership. (415) 332-5442 or Leeloves2sail@hotmail.com.

SAGA 409 SAILBOAT PARTNERSHIP. Belvedere, CA. Equity ownership interest in new Saga 409 cruising sloop berthed at San Francisco Yacht Club. Semi-custom Tony Castro design built by Westerly Marine. Dual staterooms, separate stall shower, Vacuflush, Garmin chartplotter, flat screen TV, stereo, microwave, wine cellar. Spectra full-batten main with Doyle StackPack and lazy jacks, roller furling jib, electric halyard/main-sheet winch, Yanmar diesel, 3-blade folding prop, much more. Fast, easy to sail, great for entertaining. \$150K plus \$200/mo. (415) 298-2080 or george@kiwi-properties.com.

J/120 PARTNERSHIP. South Beach Marina, San Francisco. 50% equity ownership. Excellent condition 1998. Great sailboat for Bay racing and/or family cruising. Fully equipped with racing and cruising inventory. Great location next to AT&T Park. Serious buyers only. (650) 477-7905 or mcbowman@pacbell.net.

BENETEAU 393 PARTNERSHIP. Sausalito. \$500. Clean, well maintained fast cruiser. Upgraded interior, winches, prop, diesel, full electronics, classic main, fully equipped. Qtr usage non-equity; may consider 1/8 or equity arrangement or sale. marigotgroup.com/strider. (415) 332-4401 or (415) 331-4900 or 393@marigotgroup.com.

SAIL THE BAY BARGAIN. 1/3 deeded partnership in Catalina 27, berthed at Treasure Island, 200 hr. on new Yanmar diesel, new bottom paint, 3 jibs, reefable main, whisker pole, well equipped. 1/3 use, will train, \$4,000, share monthly expenses. (415) 282-0875.

1/4 NON-EQUITY PARTNER in 34-ft German racer-cruiser at Sausalito Yacht Harbor. \$250 for 5 weekdays+2 weekend days per month. Fast. Tiller. Lines aft. Kevlar. Spinnaker. Well-kept. Parking. 6 months minimum. Security deposit. Call or text Val. (650) 305-9344.

WANTED - SF BAY SAILBOAT. Use/share. Willing to pay \$135 per month, use agreement for one year, with an upfront \$1,000 security deposit. Will use sailboat no more than one time per month and no more than ten times a year. Prefer a boat size, and type, such as a 30-ft sloop, and on the Sausalito side of the Bay. Experienced, meticulous, and responsible mature couple. Please call Jim in Sacramento. (916) 799-0286.



SOUTH OF THE BORDER

LA PAZ, BAJA. Sailing with a MacGregor 26X or Herreshoff 28. www.sailing-baja.com. (011-52) 612-123-5440 or info@hacienda-sol.com.



OFFSHORE/COASTAL. Passagemaking instruction. Build passagemaking and cruising skills. Captain ref. w/combined 85 years experience. Limited sailing experience OK, eagerness to get involved, understanding you're on an adventure, safety of the boat and your fellow crew members come first. Check it out at www.cruisingexpeditions.com. (805) 481-4567.



VALLARTA CATAMARAN CHARTER. Puerto Vallarta. Low season rates! Come sail with us on famous HumuHumu in perfect Banderas Bay conditions. Full day, Long Weekend or Costa Alegre Discovery Cruise. Vallarta has it all! www.catpv.com. (760) 681-7825 or (760) 975-5850 or info@catpv.com.



PLAN YOUR MEXICAN GETAWAY NOW. at the brand-new, gorgeous Cielo Y Mar condos. Located in Punta Mita, 35 minutes from Puerto Vallarta, available to rent from private owner. On the beach, 10 feet from the water, they offer spectacular views of ocean and mountains, the biggest infinity pool in the area, an endless beach, great surf breaks, great fishing, tremendous views of whales, bird life and the islands. While uncrowded and tranquil, just a five-minute walk to several waterfront restaurants. Choose from a spacious, beautifully furnished one- or three-bedroom unit, or an amazing two-story penthouse with lovely shade trellis on the top floor. To reserve, call: Dona de Mallorca, (415) 599-5012. See details: www.puntamitabeachfrontcondos.com.



CHARTER DIRECT & SAVE \$\$\$\$. Owner's time available for discount charter. Beautiful Robertson & Caine 4600 cat, Hope, featured in Latitude 38. Based in beautiful Belize. Book direct and save big bucks. pettyd@comcast.net.

TRADE

SAILING MONTEREY. Trade for boat work and/or slip fees. \$Negotiable. Trade sailing with or w/o lessons. Crealock 37 in Monterey for boat work and/or slip fees. ddatpbio@gmail.com.

SailTime: The Hassle Free Alternative to Boat Ownership



Join SailTime for a non-equity membership on our 2011 Hunter 36 – no hidden fees – just \$695 a month.

www.SailTime.com • (415) 869-2861



Get the Reliable, Powerful Wheel Pilot

Quiet & Dependable • Affordable • Built for Immersion
Easy Owner Installation • Low Power Consumption

831-687-0541

www.cptautopilot.com

Offshore/Coast Passagemaking Mexico 2010-11 • Leg 1-Baja Ha-Ha

Learn passagemaking and cruising skills from sailing veteran: daily hands on participation in instruction material, sailing drills and safety checks. Captain references w/combined 85 years experience. 805-481-4567

Instruction / Itinerary / Package Details • www.cruisingexpeditions.com

boat bottom scrubbing & more . . .

415.331.7215 william@gotzinc.com www.gotzinc.com



*A Sailor's
Consignment
Chandlery*

Official
Sponsor
2010
BAJA
HA-HA

510-769-4858

Located at Grand Marina
www.bluepelicanmarine.com

Donate your Boat

Cars, Trucks, RVs, & Real Estate
We handle all DMV & Smog
Running or Not **Tax Deduction**

BLUEWATER NETWORK | **800-324-7432**

"Proceeds help Bluewater Network reduce greenhouse gases, clean up our air and water, and protect marine mammals and wildlife."

GOLDEN STATE DIESEL MARINE

PARTS
YANMAR • UNIVERSAL • WESTERBEKE
PERKINS • ISUZU • PATHFINDER • ATOMIC 4
SERVICE
DIESEL ENGINES

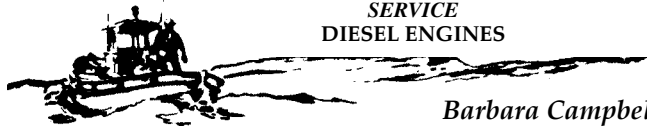

Barbara Campbell

351 EMBARCADERO
OAKLAND, CA 94606

(510) 465-1093

Mobile Marine Navigation
Installations and Marine
Electrical Work

Vessel Electric

Serving all
corners of the Bay:
North, South, East -
and San Francisco!

Raymarine
certified installer

Milltech Marine AIS

NAVPOD

Brian Theobald • (415) 424-2204 • vesselelectric@yahoo.com

MOVING TO CARIBBEAN! Arizona. \$400,000. Looking to trade/sell 3+ year old successful cigar lounge/business worth \$400K in Arizona for a 38-ft or larger sailboat. Ready to start new chapter in our lives. Serious inquiries only. www.BigSticksFineCigars.com. (602) 810-1665 or trade@bigsticksfinecigars.com.

74-FT MAST. designed for catamaran. Best offer. (415) 269-5165.

SOLID VANG SUITABLE 35'/40' BOAT. Forespar, all fittings & tackle; \$275. Outboard bracket, Edison; \$120. F/W gear, Gill womans XL; \$120. All gear as new & never used. (541) 514-3810.

WANTED

WEST WIGHT POTTER 15. 2002 to present. Call Jim. (707) 763-3444.

GEAR

18' PARATECH, 12' FIORENTINO. 9' Buord Paranchors. Anchors, windlasses, rollers. Winches: #26SS Barients, bronze Southcoast. Avon: Redcrest, motor brackets, pumps, oars. Taffrail log, bronze portholes, autopilots, MOM8, ladder, CargoMate, SS gallews, maststeps, Mastmate, BBQ's, divegear, solar, inverters, storm jibs, headsails. (415) 497-3731 or brad-low@sbcbglobal.net.

OFFSHORE SAILS-SWAN 46. Los Angeles. Doyle Main 3 Reefs; \$1275. Doyle Genoa 135%; \$1345. North Main 2 reefs; \$1150. North Genoa 135%; \$1225. Mac Shaw Delivery Main; \$575. All in excellent condition, designed for offshore use. Sail dimensions: I 58.1, J 18.7, P 51.5, E 16.9. (323) 656-6772 or ejgantz@hotmail.com.

ATTENTION BAJA HA-HA'ERS. 11' inflat, radar, windlass, ports, winches, 5hp Nissan, sails, much more. Call for details/prices. (415) 225-4319.

NORTH SAILS MELGES 24 SPINNAKER. Scotts Valley, CA. \$2,000. Power Zone reacher. All blue. Purchased in May '06, used once to win Delta Ditch race. Sold boat, sail no longer needed. New, this sail is around \$3,500. timh@cruzio.com.

UNIVERSAL M25XPB 26HP DIESEL inboard Seattle area. \$5,000. Like new-149 hours. Currently installed in my sailboat in Winslow Wharf Marina (Bainbridge Island). Come see it run. Includes prop, shaft, panel, fuel filter, cooling system, throttle/shift control. \$5,000 FIRM or trade toward 30'+ 5th wheel/travel trailer. (360) 643-9113 or jn5289@yahoo.com.

DIESELS. 3-cylinder Volvo 28hp diesel, complete with transmission; \$2,500. 4-cylinder Universal 44hp diesel with Hurth box; \$2,000. Cockroaches extra. (415) 272-5776 or 1944baby@gmail.com.

16" 3-BLADE FEATHERING PROP. for 36 - 42' sailboats. Alameda. \$1,700. PYI 16" 3-blade feathering/reversing prop. Excellent for cruising saving over half a knot from fixed props. Sells new for \$3,050. (208) 407-6505 or Doug.swanson@earthlink.net.

SAILS FOR SWAN 59. Tall rig 78' mast. Marin, CA. Best offer. Full racing set. All North Sails: .5 oz, .75 oz, 1.5 oz spinners; Mylar rope/wire sheets, afterguy; Kevlar main, #1, #3; Dacron storm, 150 cruising jibs. Excellent condition and lightly used, these sails cost over \$70k new. Sold boat, no longer need sails. Can be used for similar size rig or cut to fit. Contact North Sails for sail plan. Pickup or shipping can be arranged. DLohrey796@aol.com or (415) 948-9572.

MISCELLANEOUS

TEAK WOOD DECKING FROM BURMA. Magalia, CA. Best offer. Teak decking Burmese old growth, not plantation. Bought Oct. 1981 from American Marine Singapore. Builders of Grand Banks Yachts. Invoice shows 629 bd' 134 at 12', approx 2081' 11/2"x9/16" finished 4 sides, with 1/4x1/4 notch cut in. Kept inside and dry, like new. Have original paper work. Selling as one unit \$9,000/obo. 44 books, authors: Hayden, Hal Roth, Donald Street, Williams, Hiscock. (530) 873-1179 or (530) 873-7086 or hudolo@yahoo.com.

CLUBS & MEMBERSHIPS

ULTIMATE MEMBERSHIP. Club Nautique, Alameda - Ballena Bay. \$8,500. This membership is the BEST Club Nautique has to offer and is a great value for an avid sailor! (408) 532-7179 or (510) 326-4804 or jaw49@hotmail.com.

SINGLE SKIPPERS AND CREW of all abilities are invited to join the Single Sailors Association. Membership includes daysailing, raft-ups, invaluable onboard training, social events. Meetings held 2nd Thursday, Ballena Bay Yacht Club, www.bbvc.org. Social; 6:30 pm. Meeting; 7:30 pm. Guests welcome. www.singlesailors.org. (510) 233-1064.

NON-PROFIT

BOATING COURSES OFFERED BY USCG AUXILIARY. Boating Skills and Seamanship (power) Sailing Skills and Seamanship (sailors) courses offered by USCG Auxiliary Flotilla 17. Learn: Essentials of boating/sailing and seamanship; Navigation; Weather; Communications; Knots. Tuesday and Thursday nights, September 7 - November 9, 1930-2130 at USCG Station on Yerba Buena Island. \$75; About Boating Safely course. Our basic boating course gives you the foundation for boating safely. Saturday, September 18, 0830-1700 at YBI Coast Guard Station. \$55 includes book and lunch; GPS for MARINERS course. Learn: GPS navigation skills; functions of GPS; interface with other equipment. Saturday, October 16, 0830-1700 at YBI. \$55 includes book & lunch. Contact: (415) 205-0687 or FSO-PE@flotilla17.org.



PROPERTY SALE/RENT

LAST OF ITS KIND! Brickyard Cove Building Lot, Pt. Richmond. \$595,000. The last deepwater lot with both full San Francisco skyline views and protected water, for your dream home and dock. Some pilings in place, plans available. Last chance! (510) 367-0500 or email jadawallis@hotmail.com.

AMERICAN SAILOR. Selling harbour-side home Whangarei, New Zealand. \$US 400,000 FIRM. Fully-furnished home, pool, gardens overlooking harbour in the Onerahi suburb of Whangarei - a major re-outfitting port in Northland New Zealand. Extensive SW Pacific and Kiwi cruising community with spectacular local sailing. Intermittently lived NZ 40 years - ten in house - now at age 72 simplifying life and moving back aboard our one-off 40' Kauri cutter on marina. Website for details and 130 Flickr photos: www.americkiwihome.com. (303) 494-3154 or neptune@central.com.



AFFORDABLE LIVING IN TONGA. "Safe-Haven, Retirement, 2nd Home". Private island ocean-view lots US\$4,950 each (not a typo)! Escape congested California and live your South Pacific island paradise dreams. Protected lagoon living aboard, while building a 'Cocomo Village' home. www.tongaislandproperties.com. (619) 347-2294 or jg@TongaislandProperties.com.

BAY SAILING & WINE COUNTRY NAPA. \$3,500 / month. 4br - 3ba - 2 kit. (Un) Furnished waterfront home with boat dock in Wine Country, access to San Francisco Bay. Napa River, private boat dock (currently berthing a 41-ft sailing yacht). Amidst Fish and Game Wildlife Preserve, 50 minutes from Golden Gate Bridge. Layout of accommodation would be ideal for creating a degree of independence and privacy for part of the family (e.g. a parent(s) or adult child(ren) living at home, or visiting guests, a large glorious sun lounge with a dining area for cool evenings. Perfect for entertaining. Granite countertops, stainless steel/black appliances. Bathrooms finished in marble, Jacuzzi in master. More information and photos available from Alan. Email appcallifornia@aol.com.



WORKING WATERFRONT OFFICE(S). Pt. Richmond. \$1,000/month. Timberwharf Office(s): Overlooking Santa Fe Canal and the KKMI Marina. 1,000 square feet, easily divided. Includes two private restrooms. \$1,000 per month plus utilities. www.kkmi.com. Contact Paul Kaplan: (510) 235-5564 or paul@kkmi.com.

VACATION BY THE BAY. Tiburon condo, 2 bdrms/1 bath. Close to sailing & other Bayside recreation, SF, wine country, beaches, bike path, hiking. Community pool, high-speed wi-fi, washer/dryer. \$595/week or \$350 for 3 nights, + deposit. Available first week of October. Contact Chris. www.digsville.com/listing_photos.asp?id=34. (415) 383-8200 ext: 103 or chris@latitude38.com.

BERTHS & SLIPS

SF MARINA 30' BERTH \$295/MO. Sublet available immediately (in time for Fleet Week!). In East Harbor, near Safeway. Amazing location, great access, near ramp. Bridge views. Harbor allows 6 months sublet, so through March 2011, no problem. sublet_sf_slip@comcast.net.

40 FOOT SLIP IN SAN FRANCISCO. Pier 39 San Francisco CA. \$6,250. 40 x 14 slip. Beautiful view of Telegraph Hill. Special parking privileges Pier 39 Garage. Phone me for more info. (602) 999-0016 - 3712 E Mitchell Dr, Phoenix, Az 85018 or sally.woelfel@asu.edu.

50-FIT PRIME SLIP PIER 39, SF. \$46,000. F-Dock, Slip 11, east side. Protected from wind. Close to gangway, showers and marina office. Covered parking across street with special rates for owners. Contact (559) 355-6572 or scorch@tempest-edge.com.

36' BOAT SLIP FOR RENT OR SALE. Pier 39 Marina, East side. San Francisco. \$275/mo + utilities for rent. Best offer for sale.. "C" Dock, Slip 6. Close in to pier. Also close to showers and marina office. Available beginning Sept. 3rd. (650) 425-7777 or (650) 274-1468 or scape@justice.com.

SAUSALITO BERTH FOR 24-32 FT BOAT. \$325 per month/obo. Easy access to parking lot, tiled bathrooms and showers. Available immediately! Includes utilities and parking close to excellent variety of restaurants, Molly Stones Market, Bay Model and West Marine. Long or short term. Call if interested. (415) 999-5626.

BUSINESS OPPORTUNITIES

MARINE WOODWORKING SHOP. Great location in Sausalito at a low cost. 1,500 square feet with tools, fixtures and materials. Owner retiring after 27 years. (415) 332-2500 or jonessail@aol.com.

SAILS! SAILS! SAILS! SAILS! Major sailmakers' California sales office/territory. Well established, low overhead, Grand Marina location. Owner retiring. Will train. Sailing experience, people skills a must. \$10K. Terms available. Fun part-time job for semi-retired sailor/sailorette. leesailsnc@yahoo.com.



Waterfront! San Francisco views! 30-ft floating boat dock! Vineyard, 1.5 acres, 3 bedrooms, 3 baths. One of a fabulous kind!

www.305eaststrawberrydrive.com (Mill Valley, CA)
\$2,500,000



Golda Boeck, Broker
(415) 435-3666



NEW AND USED SAILS!

Specializing in production boats and featuring the largest selection of stock sails available anywhere! Save with warehouse volume discounts on Stock Sails, Custom Sails, Sail Covers, Furlers and Accessories. All top Quality.

All Fully Guaranteed!

- Full Batten Mains
- Furling Genoa's
- Storm Jibs
- Trysails
- Furling Units
- Custom Canvas
- Used Sails

FAST SHIPPING!

THE SAIL WAREHOUSE

VISA MasterCard
Ph. (831) 646-5346 www.thesailwarehouse.com

"YOUR DESTINATION FOR A FULL SERVICE MARINA"

CLIPPER

YACHT HARBOR
800 SLIPS 20-60 FT

- Dry Storage Available
- Fuel Dock
- Salty's Bait & Tackle
- Sport Fishing
- Restaurant
- Launch Ramp
- Pump Out
- Private Restrooms and Showers
- Laundry Facility
- West Marine
- KKMI Boat Yard
- Guest Slips Available

310 Harbor Drive, Sausalito, CA 94965
(415) 332-3500 • www.clipperyacht.com

1,000 Used Sails
Listed at
minneysyachtsurplus.com

We Buy Good Used Sails and Marine Equipment

MINNEY'S YACHT SURPLUS
1500 Newport Bl., Costa Mesa, CA
949-548-4192 • minneys@aol.com

"We keep boating affordable!"

JUST YOU AND THE SEA...



...and the jacuzzi,
the 80-ft long pool, the surf,
the Punta Mita anchorage, and the 4-mile distant
Tres Marietas Islands

Punta Mita Beachfront Condos

Call Doña de Mallorca for reservations!

1.415.599.5012

www.puntamitabeachfrontcondos.com

Bilge Steam Cleaning Oil Changes
Professional service at your slip!!!

MarineLube 877 744-2244
www.MarineLube.biz

VISA MasterCard Discover American Express

Fuel Polishing Tank Cleaning

HAWAII

LONG TERM DRY STORAGE

Clear Customs at our dock

**GENTRY'S
KONA MARINA**

HONOKOHAU HARBOR 156°1'30" W
19°40'20" N

TOLL FREE **888-458-7896**
www.gentryskonamarina.com

The friendliest boatyard in Hawaii

VOLVO PENTA

ENGINES • PARTS • SERVICE

We Ship Anywhere **1-800-326-5135**

Call us for your nearest Volvo Penta dealer 1-800-326-5135

HELMUT'S
MARINE SERVICE INC
AUTHORIZED POWER CENTER

(415) 453-1001
FAX: (415) 453-8460
www.helmutsmarine.com
619 Canal Street
San Rafael, CA 94901

ALPENGLOW LIGHTS 406.889.3586

Hand Crafted, High-Efficiency Area Light LED Swivel Reading Light in Chrome or Titanium Finish

Alpenglow Lights use the latest compact fluorescent and LED technology for unmatched efficiency and light quality. The attractive wood fixture is available in different wood choices. Dual power allows choice of bright light or gentle glow, and two levels of red. Prismatic lens designed for wide-angle illumination. Website provides helpful information on selecting cabin lighting.

Alpenglow Lights, LLC, P. O. Box 415, Eureka, MT 59917
alpenglowlights@gmail.com • www.alpenglowlights.com

Latitude 38's MEXICO-ONLY CREW LIST & BAJA HA-HA PARTY

**WEDNESDAY
SEPTEMBER 8**

6:00 to 9:00 pm

(Please, no early birds!)

ENCINAL YACHT CLUB

Pacific Marina, Alameda

**FREE for 2010 Baja Ha-Ha Skippers
and First Mates only**

\$7 at the door for everyone else
(Exact change very helpful.)

*Munchies • No-Host Bar • Door Prizes
Demonstrations • Guest Experts*



For directions and more info, see our Web page at

www.latitude38.com/crewlist/Crew.html or call us at **(415) 383-8200**

ADVERTISERS' INDEX

AB Marine..... 62	Bluerush Boardsports 73	Del Rey Yacht Club/ Puerto Vallarta Race..... 140	Gentry's Kona Marina 180	KKMI - Brokerage..... 185
Adventure Cat Charters 149	Bluewater Network..... 178	Department of Boating & Waterways..... 45	Gianola Canvas Products... 166	KKMI - Engine..... 42
Almar Marinas 57	Boat US Insurance..... 128	DeWitt Studio 167	Golden State Diesel Marine..... 178	KKMI - Full Service Boatyard 188
Alpenglow Marine Lights ... 180	Boat Yard at Grand Marina, The..... 19	Diesel Fuel Filtering 174	Grand Marina 2	KKMI - Rigging 30
Alpha Marine Systems..... 119	Boatswain's Locker 29	Dinghy Doctor, The..... 103	Hansen Rigging 69	KKMI - Systems/Electronics.. 66
Aqua Marine..... 149	Boomkicker..... 176	Downwind Marine..... 64	Harbor Island West Marina 111	Landing School, The 164
Bacon Sails & Marine Supplies 75	Bottom Sidlers..... 174	Doyle Sails 21	Harken 50	Lee Sails 176
Baja Ha-Ha Beach Party 121	Brian Toss Yacht Riggers..... 67	eMarine Systems 182	Helms Yacht & Ship Brokers 183	Leukemia Cup 139
Baja Ha-Ha Sponsors 123-125	Brisbane Marina 102	Easom Rigging..... 115	Helmut's Marine Service..... 180	List Marine Enterprises 148
Bay Area Boat Works 141	BVI Yacht Charters..... 145	Emery Cove Yacht Harbor.... 71	Heritage Marine Insurance 164	Loch Lomond Marina 103
Bay Island Yachts 8	Call of the Sea 147	Emeryville Marina 129	Hogin Sails..... 38	Lowrie Yacht Harbor 149
Bay Marine Boatworks..... 35	City Yachts..... 11	Equipment Parts Sales..... 170	Hood Sails..... 41	Makela Boatworks..... 172
Bay Marine Diesel..... 176	Clipper Yacht Harbor..... 179	Essex Credit Corp..... 36	Hotel Coral & Marina 163	Marina Bay Yacht Harbor 59
Bayside Canvas 129	Coast Marine..... 146	Euro Marine Trading 22	Hotwire Enterprises..... 172	Marina de La Paz..... 120
Bellhaven Yacht Sales & Charters..... 148	Corinthian Yacht Club..... 68	Farallone Yacht Sales..... 6, 7	Hydrovane..... 110	Marina El Cid 167
Berkeley Marina..... 65	Costa Baja Resort & Marina 63	Flying Cloud Yachts 184	Interlux Yacht Finishes 31	Marina Puesta del Sol..... 165
Berkeley Marine Center 27	Cover Craft..... 162	Forespar..... 69	Island Yacht Club..... 54	Marina Riviera Nayarit..... 56
Beta Marine Engines..... 144	Coyote Point Marina..... 37	Fortman Marina..... 32	Katadyn 109	Marina Village..... 47
Blue Pelican 178	Cruising Yachts 9	Frank Howard Allen Realtors/ Golda Boeck..... 179	Kissinger Canvas..... 71	Marine Engine Co. 174
Blue Water Yacht Insurance.. 40	CYOA Yacht Charters..... 144	Garhauer Marine..... 49		Marine Lube 180
	Defender Industries..... 68			Marine Outboard Co..... 34

continued on next page

BAY MARINE SURVEY, LLC

JESSE BRODY, SAMS-AMS

- Pre-purchase and insurance condition & value surveys
- Comprehensive inspections with detailed reports
- Based in Berkeley and serving all of San Francisco Bay



SOCIETY OF ACCREDITED
MARINE SURVEYORS®



WWW.BAYMARINESURVEY.COM
415.342.0757



Solar PV /Wind Generators
High Output Alternators
Low Power Refrigeration
Inverters/Chargers/LED's

Located in the heart of Fort Lauderdale's
Marina Mile District shipping worldwide.
Authorized Air X/Air Breeze/Whisper repair center

www.eMarineSystems.com
salesinfo@eMarineSystems.com
954-581-2505

WEDLOCK, RAMSAY & WHITING

Marine Surveyors

Vessel surveys,
consulting, deliveries.

Serving the
Bay Area
since 1980



www.norcalmarinesurveyors.com
(415) 505-3494

Ryan's Marine

*Specializing in Marine Electrical Services
for Your Boat*

- Electrical system installations from inverters to electronics packages
- Troubleshooting of existing systems
- Dealer for the complete Balmar product line
- Head and holding tank installations

MEMBER
ABYC
Setting Standards for Safer Boating

(510) 385-3842

Ryan Schofield
Owner since 1997

email:
rssailor@yahoo.com

ADVERTISERS' INDEX cont'd

Mariner's General Insurance..75	North Sails - San Francisco.. 58	Quantum Pacific..... 17	Seashine..... 74	Vallejo Marina 97
Maritime Institute..... 72	Northern California Fall Boat Show 43	Quickline..... 77	Seatech 170	Variprop USA 160
Marotta Yachts 186	Northwest School of Wooden Boatbuilding..... 74	Raiatea Carenage Services 108	Shadetree Fabric Shelter 76	Ventura Harbor Boatyard... 165
Mathiesen Marine 172	Opequimar Marine Center..167	Richardson Bay Marina 118	South Beach Harbor 60	Vessel Electric..... 178
Mazatlan Marine Center/ La Paz Yachts..... 10	Orange Coast College..... 39	Rodgers & Assoc..... 172	South Beach Riggers..... 61	Voyager Marine..... 166
McDermot Costa Insurance .. 76	Outboard Motor Shop..... 103	Rooster Sails 110	Spud Point Marina 77	Warmington Homes 18
McGinnis Insurance..... 140	Owl Harbor Marina 96	Ryan's Marine..... 182	Starbuck Canvas 8	Weatherguy.com 170
McGrath Yachts..... 23	Oyster Cove Marina..... 12	Sail California..... 14, 15	Sterling Associates 75	Wedlock, Ramsay & Whiting Marine Surveyors 182
Mettec, Inc..... 69	Oyster Point Marina 146	Sail Hasty Heart..... 147	Surveyor - Jesse Brody..... 182	West Marine 26, 28, 51
Milltech Marine Inc..... 52	Pacific Crest Canvas 67	Sail Warehouse, The 179	Sweden's Boat Works.. 25, 53	West Marine - Rigging..... 162
Minney's Yacht Surplus 179	Pacific Rigging 97	Sailrite Kits 16	Sweden's Marine 48	Westwind Precision Details... 61
Modern Sailing School & Club 33	Pacific Yacht Imports..... 4	Sal's Inflatable Services..... 122	Swedish Marine 77	Whale Point Marine Supply...44
Mystic Stainless & Aluminum, LLC..... 160	Pantaenius America, Inc. ... 174	San Francisco Boat Works...114	TMM Yacht Charters 145	White, Chris, Designs 176
Napa Valley Marina Yachts 183	Paradise Village..... 55	Sausalito Marine Electrical Shop..... 71	Tradewinds Sailing School ... 72	Wichard, Inc..... 46
New Found Metals 129	Passage Yachts..... 5	Sausalito Yacht Club - Women Skippers Regatta 8	Trident Funding 13	World Affairs Council..... 20
Norpac Yachts 187	Pier 32 Marina 163	Scan Marine Equipment..... 70	UK-Halsey Sails 73	Yachtfinders/Windseekers 10, 184
North Beach Marine Canvas..61	Pier 39 Marina 73	Scanmar International 120	Ullman Sails..... 24	
North Direct Sails..... 67	Pineapple Sails 3	Schaefer Marine 138		
North Sails 170	Pittsburg Marina 97	Schoonmaker Pt. Marina ... 161		
	Punta Mita Beachfront Condos 180	Sea Frost 70		



CELEBRATING OUR 50TH ANNIVERSARY



37' ISLANDER SLOOP
1968 • \$21,900



32' CORONADO AFT CABIN
1973 • \$19,950



35' AMUTHON STEEL SLOOP
1966 • \$18,500



30' ALBERG
1972 • \$17,900



44' SIRENA
1988 • \$109,000



36' BENETEAU 361
1999 • \$89,500



45' C&L EXPLORER CUTTER
1979 • \$59,500



47' COLIN ARCHER STEEL PH KETCH • 1972 • \$69,500



39' PEARSON 390 CENTER COCKPIT • 1972 • \$42,500



40' NEWPORTER STAYSAIL SCHOONER • 1957 • \$34,500

**For more info and listings please see:
www.napavalleymarina.com**

DRY STORAGE \$4.00/ft Power & Sail



NAPA VALLEY MARINA YACHTS

(866) 363-8882 • (707) 252-8011
1200 Milton Road • Napa, CA 94559
www.napavalleymarina.com

Marina • Boatyard • Chandlery • Brokerage

Dealers for **YANMAR**

Interlux
yachtpaint.com

Distributors for *Brownell*
Boat Stands

M U L T I H U L L S



SEAWIND 1160 Call us about charter test sail.



CHRIS WHITE HAMMERHEAD 54



PDQ 32 ALTAIR
Two boats from \$139,000.



CORSAIR 24 MKII
\$34,000.



GEMINI 105M
\$124,000.



36' SEAWIND 1000XL, 2001
Two boats from \$169,000.



CORSAIR SPRINT 750
2 starting at \$49,500.



31' CORSAIR, 1998
\$105,000.



Dealer for Seawind Catamarans
and Corsair Trimarans

www.helmsyacht.com
(510) 865-2511



CORSAIR 28CC, 2005
\$89,900.
Corsair 28AC, 1998
\$59,000.



Flying Cloud Yachts



Hans Christian



Sail • BROKERS • Power

MEMBER
Boat Wizard
M-L-S
YACHTWORLD.COM

6400 Marina Drive
Long Beach, CA 90803

www.yachtworld.com/fcyachts
flyingcloud@verizon.net

Phone (562) 594-9716
Fax (562) 594-0710



38' BENETEAU FIRST 38.5, '83 \$53,000



46' HYLAS, '06 \$595,000



TWO CATALINA 380s



2001 Hard Dodger,
LOADED! \$140,000
1998 Real nice! \$115,000



43' TASWELL, '89 \$259,000



REDUCED
SISTERSHIP
36' HUNTER, '05 ~~\$124,900~~ \$119,500



37' RANGER \$19,900



38' HANS CHRISTIAN, '86 \$149,500



MEGA upgrades
IRWIN 42, '77 \$59,500



MAKE OFFER
47' GILS CATAMARAN, '02 \$395,000



GEMINI CATAMARANS, 4 from \$49,900



42' CATALINA, '93 ~~\$118,000~~ \$109,000

APPROX. 100 LISTINGS ON OUR WEB SITE: www.flyingcloudyachts.com

Yachtfinders/Windseakers

in the heart of
San Diego's boating community

www.yachtfinders.biz

Shelter Island Dr. # 207
San Diego, CA 92106
info@yachtfinders.biz
(619) 224-2349
Toll Free (866) 341-6189



47' CATANA 472 CALIGO, '01 \$629,000
At her current price, she's at the top of the list for value, style and elegance in a multihull. Are you ready to move up?



44' SEA WOLF CC KETCH, '84 \$89,900
Black Orchid is a solid, full-keel, original-owner vessel with little use. Aluminum spars were replaced in 2004. Roomy interior!



REDUCED
42' VALIANT 42 CE, '97 \$299,000
One of the quintessential cruisers of all time, this boat combines comfort, strength, exquisite finish work and performance.



33' C&C, '85 \$37,000
Functional interior and good all-around sailing characteristics. Priced for a quick sale due to a change in circumstances.



32' CATALINA 320, '95 \$59,500
She's cruised the California coast, proving her capabilities. Possible owner financing and transferable San Diego slip a plus.



REDUCED
30' CATALINA, '80 \$21,900
A fantastic value at this price. She's very clean and also features the asked-for extras every buyer is looking for: a rare find these days!

Wasting time on facebook?

Get wasted with Latitude!

www.facebook.com/Latitude38



Maritime Yacht Brokerage

(510) 236-6633
fax: (510) 231-2355
yachtsales@kkmi.com
www.kkmi.com
530 W. Cutting Blvd.
Pt. Richmond, CA 94804

LIST WITH US! Ask us about our Maritime Protection Program



Hinckley Bermuda 40 MkII Yawl CB (1968)

Bill Tripp design B-40 is highly regarded for her classic beauty, superb workmanship and many quality details. New sails, dodger, intelligently updated. Excellent condition. Asking **\$147,000**



Nelson Marek Custom

A 92-ft aluminum world cruiser. Recently repowered. Immaculate throughout and in perfect condition. **\$1,500,000**



Swan 45 (2003)

Race or cruise. *Rancho Deluxe* won her class in the TransPac and was second twice in the Big Boat Series. This boat has all the gear to go cruising and is in perfect condition. **\$625,000**



Swan 40 (1996)

Frers design, exceptionally well maintained, 2-cabin performance cruiser. Awlgrip Flag Blue hull, comprehensive sail inventory, and full in-slip cover. Asking **\$299,000**



DeVries 86' Motor Vessel (1949/1999)

'Elegant', 'Exceptional', 'Exquisite' are just a few words that easily characterize this vessel. *MV Far Niente* clearly defines the term 'Classic Motor Yacht'. Asking **\$1,950,000**



Jarvis Newman 36 (1978)

Classic flybridge 'lobster boat' of Maine build quality. Single engine (160 hours), queen V-berth with enclosed head. Excellent condition, well maintained and lightly used. Asking **\$129,000**



Baltic 42 DP (1984) Since 1973, Baltic Yachts of Finland have been building comfortable, safe, long distance cruisers with very good sailing and performance characteristics. Doug Peterson design, superbly maintained, hull #29 of 30. Asking **\$165,000**



Little Harbor 51 (1996)

Very comfortable Ted Hood designed pilothouse with full stand-up headroom and 360° visibility. Set up for shorthanded sailing and superbly maintained by an experienced owner. Asking **\$619,000**



Marotta Yachts of Sausalito

Brokers of Fine Sail and Motor Yachts

415-331-6200 • info@marottayachts.com • www.marottayachts.com

See at: www.marottayachts.com

NEW LISTING



50' STEPHENS, 1966 Stephens were all expensive custom builds and this is a prime example. Over \$500k spent on her since '04; updated inside/out but retains her original stately lines and elegant ambiance. Possible Sausalito transferable slip. **\$227,000**

See at: www.marottayachts.com



41' SCEPTRE RAISED CABINTOP CUTTER, 1985 Professionally maintained local boat shows VERY nicely inside and out. Leisure Furl in-boom system w/Hood main, Harken roller furler and 105% Hood jib, updated electronics, more. **\$195,000**

See at: www.marottayachts.com



40' BENEteau FIRST 40.7, 2003 The First 40.7 combines the excitement of a sleek racer with all the comforts of a luxurious cruiser. This one is a well-equipped beauty that shows new inside and out. She's the deep version (preferable for the Bay). **\$179,000**

See at: www.marottayachts.com

REDUCED



43' HANS CHRISTIAN, 1978 Classic offered for sale by original owner. New teak decks (this was a \$40,000 job alone!), Awlgrippd hull, updated interior, optional larger diesel and Telstar performance keel. **\$159,000**

See at: www.marottayachts.com

REDUCED



38' HANS CHRISTIAN, 1984 Bristol example of a classic Hans Christian with new dodger and canvas, professionally maintained brightwork, sails and machinery in fine shape. Transferable Sausalito berth. **\$114,950**

See at: www.marottayachts.com



37' HUNTER 376, 1999 Very spacious, light and airy, this vessel shows as new; must see to appreciate. Out-of-country owners motivated; offers encouraged. Sausalito Yacht Harbor slip can be arranged. **\$97,000**

See at: www.marottayachts.com



48' C&C LANDFALL CUTTER, 1980 Landfall is C&C's first large boat w/emphasis on cruising. This one is a spacious 3-cabin, 2-head cutter that's VERY competitively priced and lying in a transferable Sausalito slip. Motivated owner is encouraging offers. **\$89,000**

See at: www.marottayachts.com

REDUCED



32' CATALINA 320, 1998 Very clean (down below shows as new) and well fit out (charplotter, AP, heat/AC, dodger, bimini, etc.) deep draft model that's competitively priced and lying in a transferable Sausalito slip — a nice turn key package! **\$74,950**

See at: www.marottayachts.com



41' MORGAN OUT ISLAND, 1979 Center cockpit ketch. Never cruised and fresh water kept, she shows much newer than actual age. Note all new stainless steel ports. **\$64,000**, offers encouraged.

See at: www.marottayachts.com



38' INGRID SLOOP, 1984 Clean, never cruised, one owner example of this classic John Atkins design. A modern adaptation of pilot boats designed by Colin Archer for North Sea conditions, the Ingrid is the gold standard for capable cruisers. **\$59,000/Offers**

See at: www.marottayachts.com

NEW LISTING



36' UNION CUTTER, 1980 Heavily built full keel canoe sterned classic, designed by Robert Perry and built by the renowned Union yard in Taiwan. Repowered, aluminum mast, rigged. Offers encouraged. Competitively priced at **\$59,000**

See at: www.marottayachts.com



40' CHALLENGER KETCH, 1973 Recently Awlgrippd in beautiful Flag Blue, renewed brightwork, incredibly spacious below with 6'5" headroom. **\$49,500**

See at: www.marottayachts.com

REDUCED



38' MORGAN, 1981 Morgans are well known for quality construction and seaworthiness; high D/L ratio of 265 and long fin keel provide a comfortable ride in the Bay's boisterous conditions. Very clean in and out, with recent, dark blue Awlgrip. **\$45,000**

See at: www.marottayachts.com



35' PEARSON SLOOP, 1981 Built in Rhode Island to typical Pearson standards, this is one of the last 35s built and has been a local boat since 1983. In very nice shape, priced right and lying in a transferable Sausalito Yacht Harbor slip. A nice package! **\$35,000**

See at: www.marottayachts.com



34' HUNTER, 1984 Very roomy 34-footer in nice shape with transferable Sausalito Yacht harbor slip. Note deep draft, Yanmar diesel, custom hard dodger, oversize winches, radar and chartplotter. Competitively priced by motivated owner. Offers encouraged. **\$24,900**

NORPAC YACHTS

1150 Brickyard Cove Rd., B9, Pt. Richmond, CA 94801
(510) 232-7200 • FAX (510) 232-7202
email: info@norpac-yachts.com

THIS IS THE BEST SEASON OF THE YEAR!
THIS is the Time: LIST YOUR BOAT with NORPAC!

FOR MORE
SEE OUR

norpac-yachts.com
WEBSITE



133' CAR FERRY Conversion: Office/Studio. Ultra spacious. Fully operational. Set up for very comfortable living and working. Ice Class, built in Norway. Fine condition. Absolutely unique and VERY cool. Rare opportunity. **\$375,000**



PERFORMANCE
40' X-YACHTS X-119 SLOOP. Famous Danish builder, racer-cruiser one design by Neils Jeppesen. Loaded with gear, radar, new Volvo Penta diesel in 2000 and MORE! Proven ocean winner in Melbourne-Osaka Race. Asking **\$109,000**



LIKE NEW!
CALYPSEAUX is a beautiful **39' BENETEAU 393** Slip. Light use; presents as near-new. Dsl, dodger, 2 private stms, 2 heads w/showers, furling, self-tailers, new genny, main, Pryde 95 & 150 jibs, wheel/pedestal, pulpits, inverter, full galley mid-ship, conv't settee/ship's table, ++. **\$149,950**



NORSEMAN 447 Cutter design by Perry. 44'7" + center cockpit, dsl, watermaker, genset, solar, radar, wheel, aft S/R w/double, 2 heads, AP, furling, self-tending, dodger, bimini & MORE! Asking **\$229,950**



41' CT-41. Exquisite example of this revered Garden design w/many custom features. Fiberglass, big dsl, teak deck, cabin heat & fireplace, tiled shower & head, gorgeous interior, alum. spars, full galley, refrigeration & much MORE! MUST SEE... Asking **\$78,950**



GENTLEMEN'S CLUB AFLOAT
Established and unique SF Bay charter business featuring exotic dancers (girls and/or guys for ladies and/or gentlemen), liquor service, comfortable and spacious charter yacht w/tasteful traditional styling/decor. COI for 49 passengers. Turnkey operation, owner retiring. Asking **\$295,000**/pos. seller financing.



36' ISLANDER Slip. Well respected and outstandingly popular Alan Gurney design. Wheel steering, dsl, full dbl lineflines w/pulpits, modified fin w/skeg-hung rudder, self-tailers, rigged for short-handed sailing, furling, well laid out and comfortable down below. New trans, dodger and MORE! Asking **\$44,950**



BARGAIN!
38' GRAND BAHAMA flybridge express cruiser. Exceptionally clean, twin dsl, 2 helms, galley, enclosed head w/shower, more! Great value, asking **\$32,950**



STEEL CRUISER!
36' STEEL HARTOG KETCH. Robust bluewater cruising doubled-ender, 1985. Low hours diesel, radar genset, air conditioning, watermaker, RIB and outboard, O/S liferaft, vane, wheel, pulpits, 2x course lifelines and MORE! GREAT BARGAIN on a go anywhere cruiser! Asking **\$49,950**



BERTHED IN SAUSALITO
101' STEEL TUG in downtown Sausalito. This great YTB is operational, a fantastic opportunity with loads of potential! Bring your imagination, she's awesome, highly desirable & a fabulous value. Asking **\$44,950**

Visit us at BEAUTIFUL & FRIENDLY Brickyard Cove Marina

- SAIL**
- 100' MEGA SLOOP Custom Offshore Performance Cruiser. Comfort & luxury, spacious, sleeps 17, loaded and near new. GREAT CHARTER POTENTIAL!!! Asking 975,000
 - 58' ALDEN Boothbay Ketch. Center PH cockpit, aft S/R, dsl, heavy glass, world cruiser. AWESOME! Asking 268,950
 - 38' INGRID Ketch by Atkins. Great extra STOUT BLUE WATER CRUISER. Glass double-ender, refit & upgraded, vane, diesel, furling, RADAR & MORE! Asking 51,950
 - 38' CLASSIC English Ketch by Reg Freeman. Breathtaking beauty. **Reduced by 25,000!** Asking 99,950
 - 38' HERRESHOFF CAT Ketch. 1985. Glass, diesel, easy bluewater sailing. Asking 54,950
 - 37' HUNTER CHERIBINI Ctr. Dsl, dodger, cruise equipped, Mex. vet. NICE! Asking 34,900
 - 36' COLUMBIA. Clean and nice. Yanmar diesel, shower, wheel, dodger and more! Very reliable and FUN! **REDUCED!** Try 12,950
 - 33+ ROYAL HUISMAN ALUMINUM Cutter by Alan Gurney. World class builder and designer. Yanmar diesel, new standing rig, nav station, liferaft & MORE! Family emergency forces 50% PRICE SLASH. Must sell NOW! This is way too cheap for this vessel! Asking 19,250
 - 32' GULF P/H by Wm. Garden. Diesel, F/G and MORE. Asking 13,950
 - 32' ARIES Sloop. Double-ender by Tom Gilmer, F/G, dsl, bluewater cruiser. Asking 22,950
 - 30' STEEL Slocum's Spray replica by Roberts. Dsl, new, unfinished project... 14,900/Offer
 - 30' TRIMARAN by Augnaught. Folding, trailerable pocket cruiser. **REDUCED.** Asking 29,500
 - 24' MELGES class racer with trailer and outboard. Fast and fair. Asking 17,950
- POWER**
- 130' CAMCRAFT Passenger Ship. Certified for 33 passengers overnight. Booked for the season. Virtual turnkey. Money and opportunity, working PNW. 2,200,000
 - 100' Steel HIGH ENDURANCE ADVENTURE/CHARTER SHIP in Panama. Turnkey operation. A great opportunity! **MOTIVATED!** Asking 1,500,000
 - 85' CLASSIC TUG, '23 Vancouver Shipyard. Recent CAT V-12 repower. Massive, beautiful and seaworthy. Perfect for Classic Tug Yacht. 179,950/offers
 - 62' ELCO 1926 CLASSIC MOTOR YACHT. Twin dsl, gorgeous, elegant, comfortable. GREAT LIVEBOARD CRUISER. Must see! Offers encouraged! 148,950
- 56' HOLIDAY MANSION Cruising Catamaran HOUSEBOAT. High-end custom interior, twins and MORE! **Motivated seller has reduced her to** 42,950/offers
- 50' TRUMPY TRAWLER, Long range, great layout, 671 N-Series diesel. Needs TLC. A great boat! 44,950/offers
- 48' DUTCH CANAL Barge. Beautiful & comfortable **Sausalito liveaboard.** Steel, diesel. **MUST BE SEEN!** Asking 219,000
- 45' STEPHENS 1929 classic. Beautiful Gatsby-era motor yacht waiting to transport you back to the days of yachting in the grand style. Try 75,000
- 43' CLASSIC EXPRESS CRUISER By CALLIS. Total & magnificent professional restoration.** Beautiful, stunning, ALL VARNISHED TEAK 1923 head-turner, copper riveted, tasteful & completely modernized & updated systems. MANDARIN has a fascinating history & is an important part of the West Coast Yachting tradition. Now **VASTLY REDUCED** to a fraction of her restoration cost! **MUST SELL NOW!** Asking 98,950
- 43' MATTHEWS, '65, diesel. A gem! Loaded and beautiful. Asking 69,450
- 42' GRAND BANKS Tvl. Aft cabin, F/B, Onan, twin dsl, radar. Excellent. 121,000
- 36' SEARAY 360 aft cabin fly bridge express. Twins. Nice & a GREAT VALUE. Asking 34,950
- 34' CLASSIC LAKE UNION DREAMBOAT. We have TWO; a Blanchard and a Rothfom. Starting at a BARGAIN. 17,500 Asking
- 28' BAYLINER 2850 FLYBRIDGE SEDAN. New VOLVO/GM 300hp V8, economical & 30+MPH reported. Just completely refurbished & refitted to exceptional condition. Asking 19,950
- 27' FARALLON Pilothouse, '86. F/G, twin 5L V8s, fast and seaworthy. Just detailed and very nice. Asking 51,950
- 22' ALUMINUM PLEASURE TUG. Bufflehead live/cruise. Loaded. Asking 108,250



GREAT CRUISER!
43' POLARIS Canoe-Stern Cutter. Proven cruiser. Dsl, furling, wheel steering, full galley, 14'6" beam, enclosed marine head w/shower, ship's table/settee, windlass and a great deal more! Wonderful Robt. Perry design and a great opportunity. Asking **\$129,950**



TRADITIONAL
42' LOD SCHOONER by H. Chapelle. 48' sparrd, dsl, 1979. Excellent gaff-rigged traditional beauty in wonderful condition. THIS IS THE SCHOONER you've been looking for. Rare, exquisite and ready to go. Very few schooners of this quality ever become available. Great opportunity! Asking **\$49,500**



MAKE OFFERS!
64' SCHOONER (78' LOA). 1971. Excellent condition. Cummins dsl. Exquisite teak construction, fully fitted out for world cruising. Genset, 10 berths. Beautiful, spacious, seakindly and comfortable. Too much to describe. A fantastic vessel, incredible opportunity, rare find, and fabulous value. **MUST SEE!** Asking **\$248,950**



WORLD CRUISER!
57' BOWMAN Ketch. An AWESOME vessel completely equipped for world cruising. **TOO MUCH TO LIST;** must be seen. Has circumnavigated and also completed the Northwest Passage east to west. Seaworthy, comfortable and roomy, this is your ultimate bluewater cruising yacht. Asking **\$219,950**



44' STEEL Canoe-stern cutter by Geo. Buhler/Fred Lagier & Sons. John Deere diesel. Stout steel construction. Awesome bluewater cruiser built to go to sea and stay there. Radar, GPS, etc. Here's your world beater! Asking **\$89,995**



REDUCED!
49' CUSTOM Cold-Molded Ketch by Reliant. Beautiful Hankerson design. Powerful and seaworthy bluewater cruiser in great shape. Built '91. Yanmar diesel, furling, self-tailers, aux. genset, full galley, full electronics and MORE! **MUST BE SEEN.** Asking **\$119,950**

CALL (510) 232-7200 OR FREE (877) 444-5087
OR CALL GLENN DIRECT AT (415) 637-1181
FOR INFORMATION & INSPECTION APPOINTMENTS



**Your Complete Maritime
Service Centers**

PT RICHMOND

services including:

ENGINE SERVICE

ELECTRICAL

RIGGING

& MORE

SAUSALITO

now scheduling for:

BOTTOM WORK

FIBERGLASS

PAINTING

WELDING

"When I brought 'Cece's Rival' to KKMI, I had some concerns since KKMI is new to Sausalito and 'Cece's Rival' would probably be the smallest boat in the yard. Soon all concerns were belayed and the respect and professionalism I was shown was very reassuring and the results speak for themselves. I am very happy with all that worked on 'Cece's Rival'."

Allan Wyckoff, Harbor 25

3 **Seminars scheuled!
Rigging, Electrical &
Diesel Engine Maintenance
this October in the KKMI
Boathouse in Pt. Richmond
Call (510) 235-5564 or visit
www.kkmi.com as seminars will fill up!**

**KKMI Richmond, 530 W. Cutting Blvd., Pt. Richmond, CA 94804 (510) 235-KKMI (5564)
KKMI Sausalito, 420 Harbor Drive, Sausalito, CA 94965 (415) 332-KKMI (5564)
www.KKMI.com for yard info, rates & more about KKMI Pt. Richmond & KKMI Sausalito**