

Latitude 38

# Latitude 38

VOLUME 391 January 2010

WE GO WHERE THE WIND BLOWS

JANUARY 2010

VOLUME 391

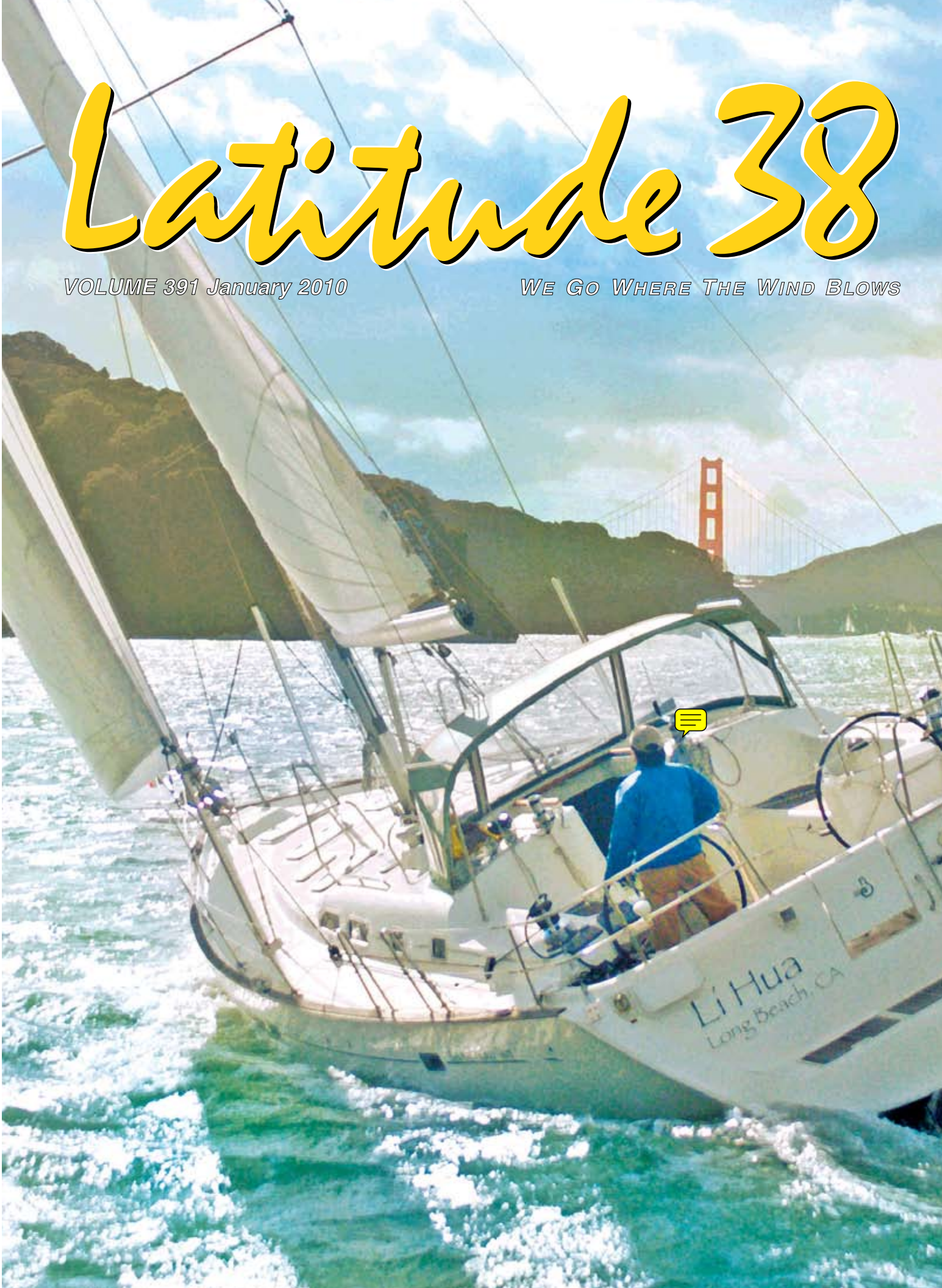



# GRAND MARINA: SIMPLY AMAZING

- Prime deep water concrete slips in a variety of sizes
- Great Estuary location at the heart of the beautiful Alameda Island
- Complete bathroom and shower facility, heated and tiled
- FREE pump out station open 24/7
- Full Service Marine Center and haul out facility
- Free parking
- Free WiFi on site!
- And much more...

## DIRECTORY of GRAND MARINA TENANTS

Bay Island Yachts.....	6
Blue Pelican Marine.....	164
The Boat Yard at Grand Marina.....	19
Lee Sails.....	158
Pacific Crest Canvas.....	53
Pacific Yacht Imports.....	9
Rooster Sails.....	71
UK-Halsey Sailmakers.....	117



**GRAND MARINA**  
ANDERSON-ENCINAL

**510-865-1200**

Leasing Office Open Daily

2099 Grand Street, Alameda, CA 94501

[www.grandmarina.com](http://www.grandmarina.com)

# Play Your Cards Right!



Last season brought successes in spades to Pineapple powered boats. Racers and cruisers alike found that dealing with Pineapple Sails brings results: sails that perform and endure.

This season offers new opportunities for mastering the many techniques of sailing. New Pineapple sails and the advice and service that go with them stack the deck in your favor.

Don't gamble. Give us a call today.

YOUR DEALER FOR: Musto foul weather gear, Dubarry footwear and Headfoil 2

Sails in need of repair may be dropped off at  
West Marine in Oakland, Alameda, or Richmond.



## PINEAPPLE SAILS

\*Powered by Pineapples

Phone (510) 522-2200

Fax (510) 522-7700

[www.pineapplesails.com](http://www.pineapplesails.com)

2526 Blanding Ave., Alameda, California 94501

# BOAT LOANS

*from*



Trident Funding

*"a fresh  
approach  
from people  
you can trust"*

*In Northern California call*  
**JOAN BURLEIGH**  
**(800) 690-7770**

*In Southern California call*  
**JEFF LONG**  
**MARGE BROOKSHIRE**  
**(888) 883-8634**

*In San Diego call*  
**MIKE LOCKARD**  
**(619) 255-5666**

[www.tridentfunding.com](http://www.tridentfunding.com)

## CONTENTS

subscriptions	6
calendar	12
letters	20
loose lips	74
sightings	76
banderas bay blast	86
a salute to roy disney	92
year in review	96
south pacific primer	102
jojo – the rest of the story	108
season champs, pt. III	112
max ebb: sail-o-matic	118
the racing sheet	122
world of chartering	130
changes in latitudes	138
classy classifieds	156
advertisers' index	166
brokerage	167

Cover: 'Li Hua' carves Raccoon Strait on a beautiful December day.

Photo: *Latitude/Rob*

Copyright 2010 Latitude 38 Publishing Co., Inc.

*Latitude 38* welcomes editorial contributions in the form of stories, anecdotes, photographs—anything but poems, please; we gotta draw the line somewhere. Articles with the best chance at publication must 1) pertain to a West Coast or universal sailing audience, 2) be accompanied by a variety of pertinent, in-focus digital images (preferable) or color or black and white prints with identification of all boats, situations and people therein; and 3) be legible. These days, we prefer to receive both text and photos electronically, but if you send by mail, anything you want back must be accompanied by a self-addressed, stamped envelope. **Submissions not accompanied by an SASE will not be returned.** We also advise that you not send original photographs or negatives unless we specifically request them; copies will work just fine. Notification time varies with our workload, but generally runs four to six weeks. Please don't contact us before then by phone or mail. Send all submissions to [editorial@latitude38.com](mailto:editorial@latitude38.com), or mail to Latitude 38 editorial department, 15 Locust Ave., Mill Valley, CA 94941. For more specific information, request writers' guidelines from the above address or see [www.latitude38.com/writers.html](http://www.latitude38.com/writers.html).

## Thinking of buying a new boat in 2010?

Despite the sluggish economy of 2009, we have sold just about all our 2009 and older inventory. We have a few boats available with good savings, but most new boats will need to be ordered. All manufacturers reduced output, and the increased buying pressure we're experiencing now is meaning longer wait times for a new boat.

Don't get left at the dock this summer. Stop by, check out the new 2010 models and get your new boat ordered. We have a few really great equipment specials on select 2010 models.

## TIME TO MOVE ON?

List with us for the sales results you want. With two Northern California offices, seven experienced sales people, and a full service department, we can give your boat the kind of professional attention it takes to sell it quickly and at a fair market price.

Last year was a banner year for used boat sales. We sold more than 40 used boats. Let us help you make our 2010 sales roster.

## SELECT LISTINGS



Beneteau 393, 2003  
Trade in! Excellent condition, loaded. \$139,500



Beneteau First 40.7  
2000 - \$124,900



Tartan 4100  
2004 - \$330,000



Beneteau 373  
2004 - \$146,500



Pearson 36  
1985 - \$66,500

SAIL	
Beneteau 473, '04	\$259,900
Hunter Legend 450, '98	159,000
Beneteau First 45F5, '91	157,500
Cascade 41, '71	59,500
Beneteau First 40.7, '00	124,900
Island Packet 40, '98	259,000
Tartan 38, '94	140,000
C&C 37+/40, '89	99,000
Island Packet 370, '04	299,000
Beneteau 36.7, '02	119,000
Fantasia 35, '79	74,900
J/109, '03	185,000
Express 34, '87	59,900
POWER	
Californian 42, '87	119,500
Sea Ray 340, '06	169,500
Carver 32, '90	39,000
Tiara 29, '98	69,900

Check out our blog: [www.passageyachts.blogspot.com](http://www.passageyachts.blogspot.com)  
See our full product listings at: [www.passageyachts.com](http://www.passageyachts.com)



### BENETEAU 43, 46, 49



2010 Models  
Order now for  
spring delivery



### BENETEAU 40



2010 Model  
in Stock



### ISLAND PACKET ESTERO 37



2010 Cruising  
World's Boat  
of the Year



### ISLAND PACKET 465



Great  
opportunity  
to own one of  
the world's  
premier cruising  
yachts.



FOR THE TIME OF YOUR LIFE

Pt. Richmond  
Office

1220 Brickyard Cove Rd  
p: 510-236-2633  
f: 510-234-0118

Two  
Locations!

Alameda Office  
Marina Village

1070 Marina Village Pkwy  
Suite 101  
p: 510-864-3000  
f: 510-337-0565

[www.passageyachts.blogspot.com](http://www.passageyachts.blogspot.com) ■ [www.passageyachts.com](http://www.passageyachts.com)

**BENETEAU**

**ISLAND PACKET**

**ALERION EXPRESS**

**WAUQUIEZ**



# Bay Island YACHTS

VISIT US ONLINE AT [WWW.BAYISLANDYACHTS.COM](http://WWW.BAYISLANDYACHTS.COM)

### NONSUCH 30 ULTRA



1984, \$65,900

### CATALINA 34



1988, \$43,900

### NONSUCH 33



1989, \$111,900

### 32' COLUMBIA 9.6



1979, \$13,000

**We've sold almost all of our  
remaining 2009 inventory.**

**If you're considering selling your boat  
in 2010, call or visit us today!**

### ~ CARIBBEAN MULTIHULLS ~

### 47' CATANA



2004. Equipped for cruising.  
430,000 euros

### 43' BELIZE



2002. Owner's version — never chartered.  
\$350,000

**(510) 814-0400**

Fax (510) 814-8765

In Grand  
Marina

2099 Grand Street, Alameda, CA 94501

[www.bayislandyachts.com](http://www.bayislandyachts.com)  
[yachtsales@bayislandyachts.com](mailto:yachtsales@bayislandyachts.com)

**YACHTWORLD.com**



## SUBSCRIPTIONS

Please read form carefully  
before submitting.

We regret that we cannot  
accept foreign subscriptions.

Check, money order, or  
credit card information  
must accompany request.

Please allow 4-6 wks to  
process changes/additions,  
plus delivery time.

eBooks email list. Free!



See [www.latitude38.com](http://www.latitude38.com) to download the  
entire magazine for free! Our eBooks are in  
PDF format, easy to use with Adobe Reader.

Email: \_\_\_\_\_

Enclosed is \$36 for one year Third Class Postage

(Delivery time 2-3 weeks; Postal Service will not forward third class, so you must  
make address change with us in writing.)

Enclosed is \$55 for one year First Class Postage (Delivery time  
2-3 days; FPO/APO (military), Canada & Mexico subscriptions are first class only)

Third Class Renewal  First Class Renewal (*current subs. only!*)

Gift Subscription Card to  
read from: \_\_\_\_\_

Name \_\_\_\_\_

Address \_\_\_\_\_

City \_\_\_\_\_

State \_\_\_\_\_

Zip \_\_\_\_\_

Phone: ( ) \_\_\_\_\_

Email: \_\_\_\_\_

**CREDIT CARD  
INFORMATION**  
Min. Charge \$12

MASTERCARD

VISA

AMERICAN EXPRESS

Number: \_\_\_\_\_

Exp.: \_\_\_\_\_

csv: \_\_\_\_\_

### INDIVIDUAL ISSUE ORDERS

Current issue = \$6.00 • With classy ad placed = \$5.00

Back Issues = \$7.00 (must indicate exact issue by month or vol. #)

### DISTRIBUTION

We have a marine-oriented business/yacht club in California  
which will distribute copies of *Latitude 38*.  
(Please fill out your name and address and mail it to the address below.  
Distribution will be supplied upon approval.)

Please send me further information for distribution outside California

Business Name \_\_\_\_\_

Type of Business \_\_\_\_\_

Address \_\_\_\_\_

City \_\_\_\_\_

State \_\_\_\_\_

Zip \_\_\_\_\_

County \_\_\_\_\_

Phone Number \_\_\_\_\_

# Latitude 38

"we go where the wind blows"

Publisher/Exec. Editor ..... Richard Spindler ..... richard@latitude38.com ..... ext. 111  
Associate Publisher ..... John Arndt ..... john@latitude38.com ..... ext. 108  
Managing Editor ..... Andy Turpin ..... andy@latitude38.com ..... ext. 112  
Editor ..... LaDonna Bubak ..... ladonna@latitude38.com ..... ext. 109  
Racing Editor ..... Rob Grant ..... rob@latitude38.com ..... ext. 105  
Contributing Editors ..... John Riise, Paul Kamen  
Advertising Sales ..... John Arndt ..... john@latitude38.com ..... ext. 108  
Advertising Sales ..... Shawn Grassman ..... shawn@latitude38.com ..... ext. 107  
General Manager ..... Colleen Levine ..... colleen@latitude38.com ..... ext. 102  
Production/Web ..... Christine Weaver ..... chris@latitude38.com ..... ext. 103  
Production/Photos ..... Annie Bates-Winship ..... annie@latitude38.com ..... ext. 106  
Bookkeeping ..... Helen Nichols ..... helen@latitude38.com ..... ext. 101

Directions to our office ..... press 4  
Subscriptions ..... press 1,4  
Classified ..... class@latitude38.com ..... press 1,1  
Distribution ..... distribution@latitude38.com ..... press 1,5  
Editorial ..... editorial@latitude38.com ..... press 1,6  
Calendar ..... calendar@latitude38.com  
Other email ..... general@latitude38.com

Please address all correspondence by person or department name

15 Locust Avenue, Mill Valley, CA 94941 • (415) 383-8200 Fax: (415) 383-5816  
[www.latitude38.com](http://www.latitude38.com)



F A R A L L O N E



## Cruising World "Boat of the Year!" Catalina 445



- Come See Us!**
- San Diego Winter Boat Show  
January 28-31  
at Sunroad Marina
  - Trawler Fest San Diego  
March 2010 - March 5-7



## Introducing 2010 R29 "Newport Edition"



### BOAT FEST MARINA VILLAGE FEB 18-21

#### Preowned Catalina Yachts

Catalina 470	2006	\$399,900
Catalina 440	2005	\$315,000
Catalina 42	2005	\$225,000
Catalina 42	2006	\$223,500
Catalina 400	2001	\$179,000
Catalina 380	1998	\$127,000
Catalina 380	1999	\$127,000
Catalina 36	2002	Sold!
Catalina 350	2004	\$129,000
Catalina 34	2007	\$139,000
Catalina 34	2004	\$129,000
Catalina 320	2001	Sold!
Catalina 320	2002	\$95,000
Catalina 310	2007	\$115,000
Catalina 280	2004	\$65,500
Catalina 270	1995	Sold!
Catalina 28	2004	\$62,500

#### Preowned Sailing Yachts

Hunter 460	2000	\$219,500
Cavalier 45	1985	\$225,000
Morgan 45CC	1992	\$149,000
Hunter Passage CC 42	1996	Sold!
Jeanneau 43	2002	\$225,000
Hunter 466	2004	\$209,500
Hunter 41	2004	\$150,000
Hunter 37	1987	\$61,500
Hunter 36	2004	\$125,000
Wylie 36	1978	\$57,500
Hunter 35.5	1993	\$59,000
Hunter 340	1998	\$79,000
Hunter 310	2000	\$50,900
Irwin 34	1985	Sold!
Cheoy Lee 32	1977	Sold!
Hunter 306	2004	\$59,500
J-100	2006	\$119,000
Coarsair 750	2007	\$49,900

#### Preowned Power Yachts

Trojan 37	1998	\$44,900
Trojan II Meter Exp 37	1988	\$49,900

#### New Ranger Tugs in Stock

Ranger 29 Tug	2010	\$214,937*
Ranger 25 Tug	2009	\$137,937*
Ranger 21-EC Tug	2009	\$49,937*
Ranger 21-EC Tug	2010	Coming

\*Base price.



J-100 2006 Reduced price to \$115,000.  
Professionally maintained  
- yacht club condition

1070 Marina Village Pkwy.  
Alameda CA 94501  
510 • 523 • 6730

2801 West Coast Hwy  
Newport Beach CA 92663  
949 • 610 • 7190  
www.faralloneyachts.com

2353 Shelter Island Drive  
San Diego CA 92106  
619 • 523 • 6730



Ray Watson & Jeannette Sarrasin  
Toll free US/CAN: 1 (888) 716-7430  
Phone & FAX: 011 52 (669) 913-3165  
E-mail: Mazmarine@aol.com



Mike Rickman & Shelly R. Ward  
Toll free US/CAN: 1 (877) 245-9689  
Phone & FAX: 011 52 (612) 123-1948  
E-mail: LaPazYachts@aol.com



[www.yachtworld.com/mazmarine](http://www.yachtworld.com/mazmarine)



60' BUCHANAN CLASSIC KETCH, 1963...\$755,000

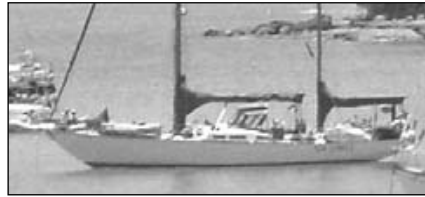

54' DEWAR CUSTOM CUTTER, 1983...\$149,900



54' HUNTER SLOOP, 1983...\$90,000



50' MARINER MS CUTTER, 1980...\$175,000



45' DOWNEAST CUTTER, 1980...\$114,900



45' ISLAND TRADER CC CUTTER KETCH, 1979...\$139,900



45' HUNTER PASSAGE 450 CC, 1998...\$165,000



44' JEANNEAU SUN MAGIC 44, 1990...\$125,000



43' BENETEAU OCEANIS 430, 1989...\$115,000



42' SKIP JOHNSON TRIMARAN, 1987...\$165,000



40' ROBERTS CC CUTTER SLOOP, 1980...\$87,000



38' HANS CHRISTIAN TRADITIONAL, 1979...\$75,900



37' TAVANA KETCH, 1975...\$54,900



37' ENDEAVOUR SLOOP, 1978...\$60,000



36' CATALINA SLOOP, 1983...\$47,500



34' HUNTER SLOOP, 1986...\$28,500



32' ISLANDER SLOOP, 1971...\$18,000



30' ERICSON SLOOP, 1968...\$18,000

☉ Re-opening PV Yachts in Marina Vallarta, Puerto Vallarta ☉

For information on listing your boat for sale, call us at 011 52 (669) 913-3165 or email Mazmarine@aol.com  
Offices in Mazatlan, La Paz, Baja California ☉ Check our monthly ads in Latitude 38

**MANY MORE LISTINGS ON OUR WEBSITE AT WWW.MAZMARINE.COM**



# Exclusive West Coast Dealer for Tayana Yachts



## TAYANA 54 DECK SALON AT OUR DOCKS



### SELECT BROKERAGE



**2007 TAYANA 48 DECK SALON**  
*Calmate* has a beautiful LPU navy hull and is loaded with gear. Radar arch, davits, Leisurefurl boom, electric winches, full canvas and up to date electronics. **\$525,000**



**2005 TAYANA 48 CC**  
 Just back from Mexico in great shape with everything you need for this year's Baja Ha-Ha. **\$469,000**



**2010 TAYANA 58 DECK SALON**  
 Nine months from now you could be sailing your new yacht with a custom interior designed by you. Base price **\$610,000** F.O.B. Alameda, CA.



**2005 TAYANA 64 DECK SALON**  
 Beautiful, fully equipped, 4 stateroom, 3 head vessel. LeisureFurl main, electric winches, bow thruster. **\$995,000**



**2010 TAYANA 48 DECK SALON**  
 New build at the factory ready to finish with your equipment choices. Two at this price. **\$430,000**



**2007 TAYANA 46 PILOTHOUSE**  
 Cruise in comfort in any climate with inside steering. With only 12 hours on Yanmar 100 hp dsl, she's virtually new. Over 1,000-mile range under power. **\$335,000**



**1988 FRASER 51 CUTTER**  
*Wingstar* is a Canadian-built center cockpit cutter. Great shape and ready to go again. **\$229,000**



**1984 TAYANA 42 AFT COCKPIT**  
 In great shape and ready to go! Recent upgrades include new Doyle sails, bow thruster, rigging, Awlgrip LPU, AGM batteries and inverter. **\$145,000**



**1973 BREWER 43 CC KETCH**  
 Custom center cockpit teak ketch properly maintained by a meticulous owner. **\$69,000**



**1985 HANS CHRISTIAN 38**  
 Proven bluewater cruiser in great shape and ready for her next adventure. **\$109,000**



**1990 TAYANA 55**  
 Well cared for and consistently upgraded. New teak decks in 2006. New engine 2008. Lying Turkey. **\$395,000**



**1997 TARTAN 4600**  
 Must see! Custom Kevlar reinforced hull. Beautifully maintained with a huge inventory of equipment and sails. **\$349,000**

# Pacific Yacht Imports

2051 Grand Street, Alameda, CA 94501

[www.pacificyachtimports.net](http://www.pacificyachtimports.net)

We're at Grand Marina

Dave Wolfe • Neil Weinberg

Tel (510) 865-2541 Fax (510) 865-2369

[tayana@mindspring.com](mailto:tayana@mindspring.com)



# Discover Brisbane Marina

**Brisbane Marina welcomes  
Golden Gate Charter, LLC,  
to our line of services.**

**Call Grant Gilliam for luxury  
yacht charter information.**



**(650) 773-3311**  
**grant@ggcharter.com**  
**www.ggcharter.com**



**From Hwy 101, take the  
Sierra Point Pkwy exit and  
follow the signs to the marina.**

**400 Sierra Point Parkway  
Brisbane, CA 94005**

**(650) 583-6975**

**www.ci.brisbane.ca.us**  
**harbormaster@ci.brisbane.ca.us**

## Yachtfinders/Windseakers in the heart of San Diego's boating community

2330 Shelter Island Dr. # 207, San Diego, CA 92106  
info@yachtfinders.biz

Go to  
**www.yachtfinders.biz**  
for all our 80+ listings!

**(619) 224-2349**  
Toll Free (866) 341-6189



**58' FARR CC, '87** \$396,900  
Imagine has been circumnavigated, impeccably maintained and constantly upgraded by her fastidious owners.



**50' CHEOY LEE OFFSHORE, '70** \$199,000  
This wonderful Alden design is an absolute joy to sail. She is easily handled by some sailors singlehanded.



**50' DAVIDSON CUSTOM, '82** \$174,000  
Laurie Davidson classic with great potential as a racer or fast cruiser. Seller will accept smaller boat (power or sail) in trade.



**50' SANTA CRUZ, '82** \$179,000  
This well maintained, near-stock Santa Cruz 50 continues to be the best of her type for performance cruising or distance racing.



**44' LANCER PH MS, '80** \$95,000  
This ultimate spacious motorsailer has been loved and well maintained. Popular pilothouse design that's rarely seen.



**36' ALLIED PRINCESS, '76** \$29,900  
Built for offshore sailing, she is well structured and sturdy. You'll be in good company, anchored in exotic ports.



**36' CATALINA MK II, '97** \$89,900  
Clean, well maintained vessel with modernized, sleeker hull and upgraded interior has all that's needed for enjoyable sailing.



**32' CATALINA 320, '98** \$73,500  
She is the perfect all-around vessel, with large cockpit, ideal for day sailing, weekend cruising, and club racing.



**30' SANTANA, '80** \$18,900  
Proven and worthy, she provides a spacious, neat and clean interior - something seldom found on a 30-footer!



**30' CATALINA, '78** \$14,500  
Priced to sell. Wheel steering and full deck cover. Excellently cared for; nothing complicated or compromised.



**29' LANCER, '78** \$9,200  
Priced to sell quickly. This is one very clean, very pretty, good deal. The sails, rig, and hull appear to be in great shape.



**28' ERICSON 28+, '81** \$22,900  
An extremely well outfitted little ship in turn-key condition, this boat has sailed to Hawaii and back.

San Francisco's yacht broker since 1969 ~ celebrating our 40th year!

# Cityyachts YACHTS AND THE CITY



32' Silverton, '98 \$85,000

*Happy  
New Year!*



35' Maxum, '01 \$79,000



Cabo Rico 38, '81 \$85,000



Hylas 42, '89 \$154,900



32' Grand Banks, '80 \$89,900



46' Moody, '00 \$399,000



26' Tollycraft, '79 \$16,500



32' Capitol Yachts Gulf, '85 \$42,500



28' Bayliner 2855, '00 \$44,500



Carver 30, '93 \$59,900



35' Niagara, '80 \$58,500



43' Gran Mariner, '77 \$85,000



47' Chris Craft Commander, '74 \$199,000



Catalina 34, '94 \$63,000

10 MARINA BL. • SAN FRANCISCO, CA 94123 • Toll Free: 877-444-5091 • 415-567-8880  
FAX (415) 567-6725 • email: sales@citysf.com • website: www.citysf.com



PLEASE VISIT OUR FUEL DOCK AT GASHOUSE COVE MARINA • OPEN 7 DAYS A WEEK • 9AM TO 5PM



- 100% Epoxy-Infused Hulls & Decks
- Carbon Fiber Masts
- 15-Year Transferable Hull Warranty

See both of these beautiful boats in the water at the

January 29 – February 6  
South Lake Union, Seattle, WA



NEW Tartan 3700 CCR #144

CLEARANCE SALE!  
BLOWOUT

5 Sold!



WAS \$346,061 ~ NOW \$286,061 ~ SAVE \$60,000

NEW C&C 115 #76

CLEARANCE SALE!  
BLOWOUT

8 Sold!



WAS \$281,871 ~ NOW \$231,871 ~ SAVE \$50,000

West Coast Dealers for:



Ask about our San Juan Islands 'Offshore Delivery Program'.  
Cruise the beautiful Pacific Northwest sales tax-free.



since 1977

**Marine  
Servicenter**

Seattle • Anacortes, WA

(206) 323-2405

(877) 215-0560 (toll free)

www.marinesc.com

# CALENDAR

## Non-Race

**Dec. 31** — Only once in a blue moon does the blue moon land on New Year's Eve, but it does today.

**Jan. 1** — Cure that hangover with a head-clearing sail!

**Jan. 1** — 'Round the Island circumnavigation of Alameda. Starts at Island YC, then on to Aeolian YC and Ballena Bay YC, finishing at Encinal YC. Info, [IslandYCEvents@yahoo.com](mailto:IslandYCEvents@yahoo.com).

**Jan. 3-31** — Free sailing at Pier 40 every Sunday courtesy of BAADS. Info, (415) 281-0212 or [www.baads.org](http://www.baads.org).

**Jan. 4-Mar. 26** — Full-Time Sailmaking & Rigging Course at Northwest School of Wooden Boat Building in Port Hadlock, WA. Info, [www.nwboatschool.org](http://www.nwboatschool.org) or (360) 385-4948.

**Jan. 6** — Club Nautique's Winter Wednesdays Seminar Series continues with 'Yacht Design—Under the Water, Part I' with instructors Ted Strand & Jim Hancock at Club Nautique in Alameda, 6-8 p.m. Seminars run every other Wednesday at the same time and location, and are free unless noted. **1/20:** 'Yacht Design—In the Air, Part II' with Kame Richards; **2/3:** 'Chartering in the BVIs' with Rod Witel. Info, (510) 865-4700 or [www.clubnautique.net/winter-wednesdays](http://www.clubnautique.net/winter-wednesdays).

**Jan. 6** — Registration at Santa Cruz Harbor for three USCGA classes, 7-8:30 p.m.: Coastal Navigation (starts 1/11), Boating Skills & Seamanship (starts 1/13), and Sailing Skills & Seamanship (starts 1/14). Info, [wscgaux@gmail.com](mailto:wscgaux@gmail.com).

**Jan. 6-27** — Wednesday Yachting Luncheon Series at St. Francis YC, 12-2 p.m., \$13.50. Enjoy lunch and a dynamic speaker every Wednesday. All YCs' members welcome. More info under the 'Events' tab at [www.stfyj.com](http://www.stfyj.com).

**Jan. 9** — Advanced Sail Trim seminar at Tradewinds Sailing School & Club in Pt. Richmond, 10 a.m.-1 p.m. \$20 for members; \$30 for non-members. Info, (510) 232-7999 or [www.tradewindssailing.com](http://www.tradewindssailing.com).

**Jan. 12-Feb. 2** — America's Boating Class by Marin Power & Sail Squadron in Novato on Tuesdays and Thursdays, 7-9 p.m. Textbook, \$40. Info, (415) 924-2712.

**Jan. 13-17** — 50th Annual Portland Boat Show at the Expo Center. Info, [www.otshows.com](http://www.otshows.com).

**Jan. 14** — Single sailors of all skill levels are invited to the Single Sailors Association monthly meeting at Ballena Bay YC, 7:30 p.m. Featuring Jim Connolly's Moroccan Adventure presentation. Info, [www.singlesailors.org](http://www.singlesailors.org) or (510) 233-1064.

**Jan. 16** — Basic Race Management Seminar by US Sailing's Bill Gage at Encinal YC, 8 a.m.-5:30 p.m. \$40 for US Sailing members, \$70 for non-members. Contact Larry Westland at (510) 459-5566 or [lwestland@tricommercial.com](mailto:lwestland@tricommercial.com) for info.

**Jan. 16** — Free 12-Volt Charging Systems seminar at Sausalito Marine Electrical Shop, 10 a.m.-12 p.m. Space limited — contact [info@sausalitomarine.com](mailto:info@sausalitomarine.com) or (415) 332-9030.

**Jan. 20** — Yacht Interior Trends 2010 at Pasta Pelican in Alameda, 6-7 p.m. Info, [www.wrightwaydesigns.com](http://www.wrightwaydesigns.com).

**Jan. 28** — Modern Sailing School & Club presents Marc & Doreen Gounard: Family Cruising Adventures on a Home-Built Catamaran at Golden Gate YC, 6:30-10 p.m. Free. Info, (415) 331-8250.

**Jan. 28-31** — San Diego Sunroad Boat Show at Sunroad Resort Marina on the east end of Harbor Island. Info, [www.bigbayboatshow.com](http://www.bigbayboatshow.com).

**Jan. 29** — Howl at the full moon on a Friday night.

**Jan. 29-Feb. 6** — Seattle Boat Show Indoors & Afloat, at Qwest Field Event Center and Lake Union's Chandler's Cove. The largest boat show on the West Coast. Visit [www.seattleboatshow.com](http://www.seattleboatshow.com) for more info.

**Jan. 30** — Sail Repair & Kits seminar at Tradewinds Sailing School & Club in Richmond, 10 a.m.-1 p.m. \$20 for members; \$30 for non-members. Info, [www.tradewindssailing.com](http://www.tradewindssailing.com) or



ALAMEDA	(510) 521-5544
SAN DIEGO	(619) 681-0633
NEWPORT BEACH	(949) 650-7245
MARINA DEL REY	(619) 681-0633

*Your Passport to the Cruising Lifestyle*

## Visit us at the San Diego Sunroad Boat Show, January 28-31, 2010



New Boat

**2008 JEANNEAU 39i  
NEW! \$237,725**



A must see

**2008 JEANNEAU 54DS  
LIKE NEW! \$645,000**



Make Offer

**2002 HUNTER 466  
ASKING \$238,000**



Pristine!

**2003 JEANNEAU 45.2  
DON'T MISS! \$269,500**



Make Offer

**1976 CT TA CHIAO 41  
OFFERED AT \$99,000**



A must see

**2008 HUNTER 41 DS  
LIKE NEW! \$228,500**



San Diego

**2004 HUNTER 386 LE  
OFFERED AT \$135,500**



Great Deal

**1993 HUNTER 37.5  
ASKING \$71,900**



Don't wait

**2005 CATALINA 36  
MUST SEE! \$134,500**



Go Sailing!

**1986 FREEDOM 36  
OFFERED AT \$66,900**



Very Clean

**2007 HUNTER 31  
LIKE NEW! \$84,000**



San Diego

**2001 HUNTER 290  
GO SAILING! \$29,995**

### More Pre-Cruised Yachts

1975 Ferro Cement 56	\$60,000
2008 Jeanneau 45DS	\$330,000
2004 Hunter 44 DS	\$209,500
1997 Beneteau 42.7	\$179,000
2006 Jeanneau 42DS	\$249,000

2005 Hunter 41 AC	\$185,000
2001 Hunter 410	\$139,950
1977 Newport C&C 41	\$59,900
2004 Hunter 386 LE	\$136,900
1991 Hunter 37	\$64,500
1987 Catalina 36	\$49,500

2007 Hunter 36 - 2 avail.	\$149,500
2004 Hunter 36	\$99,900
2004 Jeanneau SO 35	\$129,900
1984 LM Mtrsailer 30	\$59,000
1996 Hunter 280	\$29,900
1992 Catalina Capri 26	\$15,950

Proudly Representing



# www.CruisingYachts.net

# FAST IS FUN!

## SC<sup>37</sup> Santa Cruz YACHTS



Win the  
Pacific Cup 2010  
TransPac 2011

### SCORCHING SPEED! Plus:

Easier to sail, easier to manage.

Efficient design means smaller offshore crews to Mexico or Hawaii. Try it.

Call for a test sail...

and hold on tight!

Dealers for Santa Cruz Yachts in California

# SAIL California

Alameda  
(510) 523-8500  
norman@sailcal.com



Newport Beach  
(949) 675-8035  
San Diego  
(619) 224-6200  
jeff@jk3yachts.com

www.jk3yachts.com • www.sailcal.com  
www.santacruzayachts.com

## CALENDAR

(510) 232-7999.

**Jan. 30** — About Boating Safely course by USCGA Flotilla 12-21 at Encinal YC, 9 a.m.-3:30 p.m. \$35 book fee. Email [rafegaux@sbcglobal.net](mailto:rafegaux@sbcglobal.net) to pre-register.

**Jan. 30 & 31** — Baja Ha-Ha Assistant Poobah 'Banjo Andy' Turpin will present a Ha-Ha seminar and a Pacific Puddle Jump talk back-to-back on both days at the Seattle Boat Show. See [www.seattleboatshow.com](http://www.seattleboatshow.com) for times.

**Feb. 6** — 21st Annual Women's Sailing Convention at Bahia Corinthian YC in Corona del Mar, \$165. Info, [www.scya.org](http://www.scya.org).

**Feb. 7** — Take a three-hour family Adventure Sail on the Bay aboard *Hawaiian Chieftain*, 2 p.m. Adults, \$55; Kids, \$35. Info, [www.historicalseaport.org](http://www.historicalseaport.org).

**Feb. 9-May 4** — Sailing Skills & Seamanship Class by USCGA Sausalito at Station Golden Gate, 7:30-9:30 p.m. \$75 fee. Info, (415) 328-6480 or [greenibsonsg@yahoo.com](mailto:greenibsonsg@yahoo.com).

**Feb. 10 & 25** — How the Tides Work for You presentation by Kame Richards at the Bay Model in Sausalito, 7 p.m. Space fills quickly for this popular seminar where you'll learn how to use the Bay's currents to your advantage. \$15 (cash only). Reservations, [jimtantillo@comcast.net](mailto:jimtantillo@comcast.net) or (408) 263-7877.

### Racing

**Jan. 1** — Master Mariners New Year's Day Race and Chili Potluck at Pt. San Pablo YC in Pt. Richmond. Info, (415) 364-1656 or [www.mastermariners.org](http://www.mastermariners.org).

**Jan. 2** — Burr Rabbit. CPYC, [regatta@cpyc.com](mailto:regatta@cpyc.com).

**Jan. 16** — Richmond YC Little Daddy Regatta. Big Daddy will follow March 13-14. Info, [www.richmondyc.org](http://www.richmondyc.org).

**Jan. 18-22** — Key West Race Week presented by Nautica, the best regatta in the U.S. Info, [www.premiere-racing.com](http://www.premiere-racing.com).

**Jan. 27-30** — The Superyacht Cup Antigua. Watch beautiful people sail beautiful boats in a beautiful venue. Info, [www.thesuperyachtcup.com](http://www.thesuperyachtcup.com).

**Jan. 30** — Three Bridge Fiasco, one of the oddest and most entertaining races ever invented, and the first SSS event of the season. Info, [www.sfbaysss.org](http://www.sfbaysss.org).

**Feb. 6** — Double Up & Back. CPYC, [regatta@cpyc.com](mailto:regatta@cpyc.com)

**Feb. 13-14** — Londerville Cup. Half Moon Bay YC, [www.hmbyc.org](http://www.hmbyc.org).

**Feb. 18-27** — Vallarta Race, a 1,000-mile race from San Diego to PV, followed by MEXORC. Info, [www.sdy.org/pv](http://www.sdy.org/pv).

**Feb. 27-Mar. 6** — MEXORC Regatta, held in conjunction with Copa Mexico. Info, [www.mexorc.com](http://www.mexorc.com).

**June 19** — The Singlehanded Transpac from SF to Hanalei. If you've been wanting to prove your mettle, this could be your year. Info, [www.sfbaysss.org](http://www.sfbaysss.org).

**July 5** — 16th Biennial Fun Race to Hawaii, aka the Pacific Cup. For details on the race and seminars, visit [www.pacificcup.org](http://www.pacificcup.org).

### Midwinter Regattas

**BERKELEY YC** — Midwinters: 1/9-10, 2/13-14. Chowder Races: Sundays through March except when it conflicts with above. Bobbi, (925) 939-9885.

**CAL SAILING CLUB** — Year-round Sunday morning dinghy races, intraclub only, typically in Laser Bahias and JY15s. Email Gary and Alistair at [racing\\_chair@cal-sailing.org](mailto:racing_chair@cal-sailing.org).

**CORINTHIAN YC** — Midwinters: 1/16-17 & 2/20-21. Donal Botkin, [racing@cyc.org](mailto:racing@cyc.org).

**ENCINAL YC** — Jack Frost Series: 1/23, 2/27, 3/27. Small Boat Winter Series: 1/30, 2/27, 3/27. Matthew Dean, [rearcommodore@encinal.org](mailto:rearcommodore@encinal.org).

**FOLSOM LAKE YC** — Winter Series: 1/16, 2/13, 3/13, 4/3. Mark Erdrich, [fusion927@gmail.com](mailto:fusion927@gmail.com).

# SAIL *California*

## YOUR PERFORMANCE YACHT SPECIALISTS

**ALAMEDA**  
1070 Marina Village Pkwy #108  
Alameda, CA 94501  
**(510) 523-8500**  
FAX (510) 522-0641

**SEATTLE**  
**SAIL NORTHWEST**  
7001 Seaview Ave. NW #140  
Seattle, WA 98117  
**(206) 286-1004**

### Your Santa Cruz 52 Specialists



**Santa Cruz 52, 2000, Isis**  
The ultimate cruiser with a 6' draft.  
Asking \$520,000



**Santa Cruz 52, 1998, Hula**  
Deep draft for cruising, buoy and offshore, this boat has it all. Asking \$575,000



**Santa Cruz 52, 1999, Renegade**  
Medium draft; ready to go on the East Coast.  
Asking \$595,000



**J/100, 2005, Reddie Freddie**  
Now asking \$112,000



**J/32, 2001, Independence**  
This is an amazing amount of boat at 32-ft.  
Come see her on our sales dock. Asking \$125,000



**J/109, 2004, Crazy Diamond**  
Deal of the decade.  
Asking \$185,000



**J/40, 1986, China Cloud**  
This boat is ready for the Baja Ha-Ha. Are you?  
Asking \$159,000



**J/124, 2007, Fortuna**  
For the joy of sailing, experience the J/124.  
Asking \$298,000



**1D35, Great Sensation**  
Total refit inside and out.  
Asking \$84,900



**Olson 40, 1983, Elka**  
Asking \$79,000

77' Andrews, '03\*\*.....Reduced! \$799,000  
56' Andrews, '94, *Charisma*.....SOLD  
52' Santa Cruz, '00, *Isis*.....\$520,000  
52' Santa Cruz, '98, *Hula*.....\$575,000  
52' Santa Cruz, '99, *Renegade*.....\$595,000  
48' J/145, Hull #9, '03\*\*.....Reduced! \$675,000  
44' J/44, '93, *Halcyon Days*.....Just Listed \$315,000  
44' J/44, '90, *Phoenix*.....SOLD  
41' J/124, '07, *Fortuna*.....Reduced! \$298,000  
41' Passport, '90, *360*\*\*.....Reduced! \$239,000  
40' Avance, '85, *Caribou*\*\*.....Reduced! \$139,500  
40' X-Yachts X119\*\*.....SOLD  
40' Olson 40, 1983, *Elka*.....\$79,000  
40' J/40, '86, *China Cloud*.....\$159,000  
40' J/120, '01, *OuiB5*.....Reduced! \$199,000  
39' Carroll Marine CM 1200, '95\*\*.....\$82,500  
39' Schumacher Custom, '96, *Recidivist*.....\$149,000  
38' X-Yachts 382, '99, X-TC.....SOLD

37' X-Yachts 372 Sport, '87.....SOLD  
37' J/37, Hull #30, '88.....SOLD  
36' J/36, '83\*\*.....SOLD  
35' J/109, '03\*\*.....\$189,000  
35' J/109, '04, *Crazy Diamond*.....Reduced! \$185,000  
35' J/105, Hull #497, '02, *Breezy*.....SOLD  
35' J/105, Hull #298, '00, *Chilax*.....\$114,000  
35' J/105, Hull #347, '00, *Bald Eagle*.....Reduced! \$109,000  
35' J/105, Hull #617, '04, formerly *Chilli Pepper*\*\*.....Reduced! \$105,000  
35' J/105, Hull #403.....SOLD  
35' J/105, '99, *Life Is Good*\*\*.....\$83,000  
35' J/35, '84, *Blue Streak*\*\*.....\$37,900  
35' J/35, '84, *The Boss*\*\*.....\$49,000  
35' 1D35, '00, *Great Sensation*.....\$84,900  
35' 1D35, '01, *Tabasco*.....\$79,000  
35' 1D35, *Sweet Sensation*.....\$69,000  
35' 1D35, '99, *Sensation*.....\$64,000

35' 1D35, '01, *Yeofy*.....\$69,900  
35' Ericson 35 Mk III, '84, *Symmetry*.....SOLD  
34' D-Class Catamaran, *Rocket 88*.....\$38,000  
34' MJM 34z, '05\*\*.....Reduced! \$365,000  
34' J/34, '85, *The Zoo*\*\*.....Reduced! \$29,900  
34' Olson-Ericson, '89\*\*.....\$47,500  
33' J/100, Hull #5, '05, *Reddie Freddie*.....Reduced! \$118,000  
32' J/32, *Independence*, '00.....\$125,000  
29' Back Cove, '05, *Diamond Lil*.....SOLD  
29' MJM 29z, '07\*\*.....\$269,000  
29' J/29, '85, *Masthead*\*\*.....SOLD  
28' Alerion Express, '06\*\*.....Reduced! \$105,000  
27' Choate, '79, *Allegro Con Brio*.....SOLD  
27' Antrim 27, '98, *Luna*.....Reduced! \$29,900  
26' J/80, '01, *Lay Down Sally*.....SOLD  
22' Aquapro Raider 665, '04.....Pending \$34,900

\*\* Indicates Seattle Boats

# SAIL *California*

www.sailcal.com  
email: norman@sailcal.com

DEALERS FOR THESE FINE YACHTS:

**SABRE**

**Santa Cruz**  
YACHTS

**SUMMIT**  
YACHTS

**J**  
BOATS

# SAIL *California*

## WELCOMES STEVE TAFT

If you're looking for the perfect boat, start with an exceptional broker.

Steve Taft has spent a lifetime sailing and has worked in all sectors of the sailing industry. He brings unequalled insights and experience to the



Sail California team. With 18 years as the manager of North Sails in Alameda, 13 years as manager of Bay Marine Boatworks in Richmond, and sailing in countless Bay and offshore races, Steve has the knowledge to match your vision to the perfect boat.

"I've worked and sailed with both Norman and Pat at Sail California for many years, and the quality of their operation, clientele, and the boats they work with has always impressed me," stated Taft. "The addition of Santa Cruz Yachts and Summit Yachts to the J/Boat performance line gives them an enticing selection of new, high-performance boats, and their line-up of brokerage boats is the best you'll find anywhere. With boats like the Santa Cruz 52, a J/44, J/120, and Olson 40 listed, Sail California offers a terrific selection for almost any buyer. Many great opportunities are available right now."

Buying or selling, you won't find a broker on the Bay with more knowledge of the boat you have or the boat you want.

Call Steve about the just-listed Santa Cruz 52 Hula Girl or any of our new boats or pre-owned listings.

# SAIL *California*

[www.sailcal.com](http://www.sailcal.com)  
email: [norman@sailcal.com](mailto:norman@sailcal.com)

### ALAMEDA

1070 Marina Village Pkwy #108  
Alameda, CA 94501  
(510) 523-8500  
FAX (510) 522-0641

### SEATTLE

SAIL NORTHWEST  
7001 Seaview Ave. NW #140  
Seattle, WA 98117  
(206) 286-1004

## CALENDAR

**GOLDEN GATE YC** — Seaweed Soup Series: 1/9, 2/6, 3/6. Mont, [gyyccracedeck@aol.com](mailto:gyyccracedeck@aol.com) or (209) 481-5158.

**HALF MOON BAY YC** — Midwinters: 1/17, 2/21, 3/21. Info, [sailing@hmbyc.org](mailto:sailing@hmbyc.org) or [www.hmbyc.org](http://www.hmbyc.org).

**ISLAND YC** — Estuary Midwinters: 1/10, 2/14, 3/14. John, (510) 521-2980 or [iycracing@yahoo.com](mailto:iycracing@yahoo.com).

**LAKE MERRITT SC** — Midwinters: 1/10, 2/13, 3/14. Beth, (510) 444-5292 or [ebuddington@earthlink.net](mailto:ebuddington@earthlink.net).

**OAKLAND YC** — Sunday Brunch Series: 1/3, 1/24, 2/7, 2/21, 3/7. John, (510) 522-6868 or [j\\_tuma@comcast.net](mailto:j_tuma@comcast.net).

**REGATTAPRO** — Winter One Design: 1/9, 2/13. Jeff, (415) 595-8364 or [jzarwell@regattapro.com](mailto:jzarwell@regattapro.com).

**RICHMOND YC** — Small Boat Midwinters: 1/3, 2/7, 3/7. Tony, [amcastruccio@sbcglobal.net](mailto:amcastruccio@sbcglobal.net) or (925) 426-0686.

**SANTA CRUZ YC** — Midwinters: 1/16, 2/20, 3/20. Info, (831) 425-0690.

**SAUSALITO YC** — Sunday Midwinters: 1/3, 2/7, 3/7. John Mount, [race@syconline.org](mailto:race@syconline.org).

**SEQUOIA YC** — Winter Series: 1/9, 2/6, 3/13. Redwood Cup: 1/24, 2/28, 3/28. Mike Garl, [mikegarl@sbcglobal.net](mailto:mikegarl@sbcglobal.net).

**SOUTH BAY YRA** — Midwinters: 1/16, 2/20, 3/20. Jocelyn Swanson, [regatta@cpyc.com](mailto:regatta@cpyc.com)

**SOUTH BEACH YC** — Island Fever Midwinters: 1/16, 2/20, 3/20. Info, [www.southbeachyc.org](http://www.southbeachyc.org).

**TIBURON YC** — Midwinters: 1/23, 2/13, 3/13. Ian Matthew, [ian.matthew@comcast.net](mailto:ian.matthew@comcast.net) or (415) 883-6339.

**VALLEJO YC** — Tiny Robbins Midwinters: 1/9, 2/13, 3/7. Info, (707) 643-1254.

### Mexico and Beyond

**Feb. 2-7** — 9th Annual Zihua Sail Fest in Zihuatanejo, Mexico. Five days of parties, contests, potlucks, races, BBQs, auctions and chili cook-offs are what attracted more than 30 boats to last year's event, but the real payoff was raising money for local schools. These indigenous kids, many of whom are orphaned, can't attend Mexican schools until they learn to speak Spanish. Last year about \$45,000 was raised thanks in large part to matching funds raised by the Bellack Foundation and Pete Boyce, and a \$20,000 grant from Rotary International. To join in the fun and help some needy kids — even if you can't make it to the parties — go to [www.zihuasailfest.com](http://www.zihuasailfest.com).

**Feb. 6** — Pacific Puddle Jump Kick-Off Party at Vallarta YC in Nuevo Vallarta from 2-5 p.m. *Latitude 38*, Paradise Marina and the Vallarta YC team up to host the final get-together for South Pacific-bound cruisers. For details, email [andy@latitude38.com](mailto:andy@latitude38.com) or go to [www.pacificpuddlejumps.com](http://www.pacificpuddlejumps.com).

**Mar. 16-20** — The 18th Annual Banderas Bay Regatta is five days of 'friendly racing for cruising boats'. The sailing conditions and the Paradise Marina venue couldn't be better. Everybody plays it safe because they're sailing their homes, and the entry is free. It's the perfect time and place to have family and friends fly down to join you in the tropics. In fact, you'd have to be nuts to miss this one. The regatta is part of the month-long Festival Náutico Vallarta. For details, visit [www.banderasbayregatta.com](http://www.banderasbayregatta.com).

**April 8-11** — La Paz Bay Fest. This will be the fifth year for this descendant of the (in)famous La Paz Race Week. An event for cruisers that includes races, potlucks, cruising seminars and other fun activities for the family. More info on Bay Fest 2009 will soon be found at [www.clubcruceiros.org](http://www.clubcruceiros.org).

**Apr. 30-May 2** — Loreto Fest and Cruisers' Music Festival. This classic Baja event, started to clean up Puerto Escondido, draws a very large crowd of cruisers and Baja land-travellers for a chili cook-off, dinghy races and other water activities, the Candeleros Classic race, and lots of participant-created



# NOT JUST GREAT SAILS, BUT WORLD CLASS SAILMAKERS!

## WINTER DISCOUNTS!

Come in to our loft today to inquire about specials on service, new sails, and merchandise.

Sail Repair: From simple tears to extreme reconstruction

Re-Cuts: Make your old sails work again

Conversions: UV covers, roller furling, Dutchman, and more

Storage: Low winter rates on sail storage

Same day, overnight service, removal, installation, and drop off and pick up service available!



Quantum Pacific  
1230 Brickyard Cove Rd. Suite 200  
Point Richmond, CA 94801  
(510) 234-4334  
[dteakell@quantumsails.com](mailto:dteakell@quantumsails.com)  
[skesten@quantumsails.com](mailto:skesten@quantumsails.com)  
[jthorpe@quantumsails.com](mailto:jthorpe@quantumsails.com)

# Go Electric!

## PUSH-BUTTON SAIL CONTROL

Reef, furl, or set sail safely from the cockpit with the push of a button.

### EASY TO INSTALL

Harken electric furlers easily connect to your boat's existing electrical system.

### SIMPLE TO UPGRADE

Unit 2 Cruising or MKIV Unit 3 manual furlers convert to power with the Harken Upgrade Kit.

### HIGH-TORQUE, LOW-POWER MOTOR.

The small, efficient motor gives off very little heat, preventing moisture build-up.

## TECH TIP



You can adjust headstay length and tension using a standard turnbuckle housed inside the lower unit.

**HARKEN**<sup>®</sup>  
INNOVATIVE SAILING SOLUTIONS

1251 E. Wisconsin Ave., Pewaukee, WI 53072, Tel: 262-691-3320  
Fax: 262-691-3008, Email: harken@harken.com, Web: www.harken.com

# CALENDAR

music. The goals are to have fun and raise lots of money for Mexican charities in Puerto Escondido and Loreto. Visit [www.hiddenportyachtclub.com](http://www.hiddenportyachtclub.com).

**June 18-20** — Tahiti-Moorea Sailing Rendezvous, hosted by *Latitude 38* and Tahiti Tourisme. This free event is focused on cross-cultural appreciation and includes a cocktail party, a sailing rally to Moorea, Polynesian music and dance performances, and cruiser participation in traditional Tahitian sports — the highlight of which is the six-person outrigger canoe races. Info, [www.pacificpuddlejumps.com](http://www.pacificpuddlejumps.com).

Please send your calendar items by the 10th of the month to [calendar@latitude38.com](mailto:calendar@latitude38.com). If you're totally old-school, mail them to *Latitude 38* (Attn: Calendar), 15 Locust Avenue, Mill Valley, CA, 94941 or fax them to us at (415) 383-5816. But please, no phone-ins! Calendar listings are for marine-related events that either are free or don't cost much to attend. The Calendar is not meant to support commercial enterprises.

## January Weekend Tides

date/day	time/ht. LOW	time/ht. HIGH	time/ht. LOW	time/ht. HIGH
12/31Thu	0401/3.0	1012/7.1	1712/-1.6	
1/01Fri	0030/5.1	0456/2.8	1104/7.1	1756/-1.6
1/02Sat	0111/5.3	0550/2.6	1156/6.9	1840/-1.4
1/03Sun	0152/5.5	0648/2.3	1250/6.4	1925/-0.9
1/09Sat	0631/6.3	1342/0.1	2044/4.1	
1/10Sun	0054/2.8	0722/6.3	1436/-0.2	2149/4.4
1/16Sat	0057/4.9	0541/2.8	1132/5.9	1813/-0.2
1/17Sun	0123/5.0	0619/2.7	1209/5.6	1843/0.0
1/23Sat	0434/5.7	1140/1.2	1831/3.5	2232/2.8
1/24Sun	0524/5.9	1245/0.6	2010/3.7	2345/3.1
1/30Sat	0447/2.1	1058/7.0	1734/-1.2	
1/31Sun	0034/5.7	0540/1.8	1151/6.7	1815/-0.8

## January Weekend Currents

date/day	slack	max	slack	max
12/31Thu	0119	0322/2.2E	0615	0916/2.9F
	1200	1534/5.8E	1930	2234/4.4F
1/01Fri	0203	0412/2.5E	0711	1009/3.1F
	1254	1622/5.9E	2017	2321/4.5F
1/02Sat	0248	0502/2.7E	0806	1101/3.2F
	1348	1712/5.6E	2103	
1/03Sun	0905	0006/4.4F	0331	0552/3.0E
	2150	1156/3.1F	1446	1802/5.2E
1/09Sat	0218	0519/2.5F	0812	1134/4.1E
	1542	1853/3.0F	2154	
1/10Sun	0903	0015/1.6E	0318	0617/2.4F
	2254	1233/4.3E	1637	1950/3.3F
1/16Sat	0223	0435/2.1E	0751	1038/2.5F
	1326	1641/4.4E	2039	2338/3.3F
1/17Sun	0256	0512/2.3E	0830	1117/2.4F
	1405	1719/4.2E	2110	
1/23Sat	0007	0330/2.1F	0630	0948/3.5E
	1400	1644/2.1F	2004	2213/1.6E
1/24Sun	0106	0426/2.1F	0720	1045/3.8E
	1500	1755/2.4F	2117	2316/1.5E
1/30Sat	0130	0351/3.1E	0659	0956/3.6F
	1249	1604/5.8E	1953	2253/4.6F
1/31Sun	0210	0438/3.5E	0753	1048/3.7F
	1344	1652/5.4E	2036	2335/4.4F

# THE BOAT YARD AT GRAND MARINA

"Where Service Has Meaning"

**Interlux.**  
yachtpaint.com

**AWLGRIP**  
HULL PAINT

**60-TON  
TRAVELIFT**

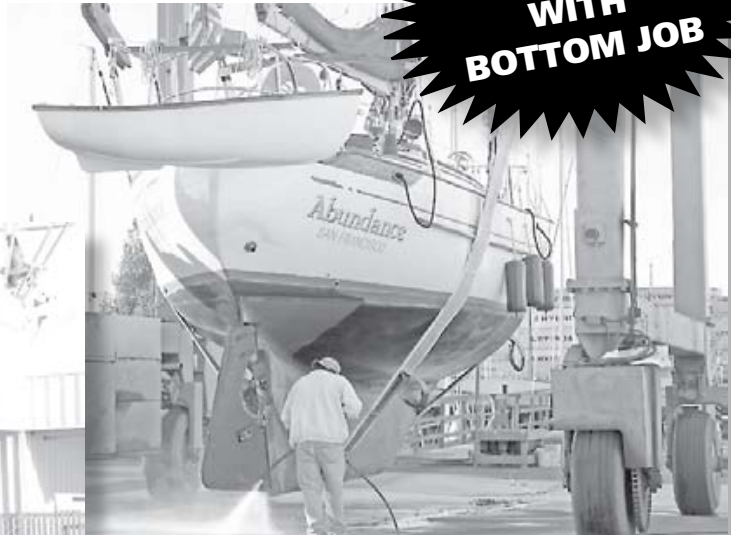

**FREE  
HULL WAX  
WITH  
BOTTOM JOB**

FEATURING  
TRINIDAD  
ANTI-FOULING PAINT BY  
**PETTIT**  
marine paint  
RATED "SUPERIOR" by  
Practical Sailor

*The only yard to brush on your bottom paint!*

Dealers for:

**MAX-PROP**  
AUTOMATIC FEATHERING PROPELLERS

**GORI**  
marine

**Webasto**

PACKLESS SEALING SYSTEM  
**SHAFT SEAL**

**LECTRA/SAN**

**SIDE-POWER**  
Thruster systems

**facnor**  
PURGING SYSTEMS INC.

**AQUAMARINE**  
FINE REVERSE OSMOSIS EQUIPMENT

## **IT'S SIMPLE!**

**Call The Boat Yard at Grand Marina for the Lowest Bottom Prices!**

~ COMPARE US WITH THE COMPETITION ~

- Prop and Shaft Work
- Mast & Rigging Repair
- Fiberglass & Blister Repair
- Gelcoat Repair
- Gas & Diesel Engine Service
- LPU Hull & Topside
- Electrical Repair & Installation

**CALL FOR A RESERVATION**

(510) 521-6100 • Fax (510) 521-3684

Located at Grand Marina • 2021 Alaska Packer Place, Alameda

[www.boatyardgm.com](http://www.boatyardgm.com)

# Sail into the New Year with a free polish & wax from Svendsen's.

With your bottom job from Svendsen's,  
get a professional polish and wax – **FREE.**



Call to schedule your service: 510.522.2886  
or schedule online: [svendsens.com](http://svendsens.com)



Svendsen's uses top-quality 3M products to give your boat a tough, unbeatably glossy finish. Schedule your haul-out today – by phone (510.522.2886) or online at [svendsens.com](http://svendsens.com).

## Svendsen's now offers computerized engine diagnosis!



- Extremely accurate
- Fast and precise
- Saves time and money

Call to schedule:  
510.522.2886



**SVENDSEN'S  
BOAT WORKS**  
1851 Clement Ave. in the Alameda Marina

## LETTERS

### ↑↓SKIP ALLAN'S YACHT IS A KAYAK

I was going through some old *Latitudes* last night, and reread the heartbreaking story from '08 about the loss of Skip Allan's Santa Cruz-based custom Wylie 27 *Wildflower*. He scuttled her about 250 miles off the coast in very heavy weather on his way back from winning the Singlehanded TransPac.

I know that Skip, who had owned the boat for more than 30 years, and who had sailed her all over the Pacific, received a couple of offers of other boats. Did he ever get another boat?

Chris Waddell

*Ad Lib*, International 110 #430  
Tomales Bay

Chris — We contacted Skip for the answer.

"No, I have not yet replaced *Wildflower*. She was such a special boat, and such a part of my life, that trying to replace her would be most difficult. I did receive a generous offer of a Hawk-farm in Idaho, but upgrading a 32-year-old lake boat was not in the works practically or financially. Nevertheless, I walk the West Coast docks most weekends surveying the fleet. But I'm not in a hurry to be paying slip rent, as I've had my hands full



COURTESY SKIP ALLAN

*Skip isn't letting the loss of his beloved 'Wildflower' prevent him from taking to the water.*

*Rubicon Point Lighthouse, which is in a forest overlooking Lake Tahoe. Abandoned in 1921, Rubicon Point is — or was — the highest lighthouse in the northern hemisphere."*

caretaking two elderly parents suffering from dementia. So, for the present, my yacht is a kayak, and my horizons are lakes, streams and backwater sloughs. The accompanying photo of me was taken at the old

### ↑↓MUSIC AND CHARTS AND APPS, OH MY

I loved your December issue *Sightings* piece about using the iPhone as a navigational aid. I'm among those few Luddites remaining who have not yet bought in to the iPhone concept, but am slowly getting there. Your article has given me an additional push. We're taking our boat *Princess*, a Sabre 402, to Alaska for the '10 season, and the concept appeals to me — especially the AIS target display feature you mentioned in the article. I have a Garmin GPS chartplotter, but it doesn't have the AIS feature.

The prices for the iPhone navigation charts and programs seem ridiculously cheap. Where do you recommend purchasing the iPhone with the navigational features you describe? I doubt that places like Best Buy understand the navigational nuances of these devices.

Bruce Munro  
*Princess*, Sabre 402  
San Francisco Bay

Bruce — You might be a little further behind the curve than

# NEW YEAR, NEW BOAT?

## VISIT A MARINA VILLAGE BROKER

Northern California  
**Boat Fest**



Marina Village Yacht Harbor  
Alameda, California

**Feb 18-21 2010**

Thu & Fri: 12-5 • Sat & Sun: 11-5

- Power & Sail
- New & Used
- 100+ Yachts For Sale
- Seminars
- Marine Exhibits
- Music & Food

**OPEN BOAT WEEKEND**  
**January 9-10**

*Farallone Yachts*



*Ranger Tugs*



*Catalina 350*



*Catalina 445*



*Catalina 470*

*Passage Yachts*



*Alerion Express 28*



*Island Packet Estero*



*Beneteau 46*



*Wauquiez 41*

*Sail California*



*Sabre Spirit*



*J/122*



*Santa Cruz 37*



*Summit 40 (King 40)*

*Farallone Yachts (510) 523-6730 • Catalina*

*Sail California (510) 523-6730 • J/Boats • Sabre • Santa Cruz Yachts*

*Passage Yachts (510) 864-3000 • Beneteau • Island Packet • Wauquiez • Alerion*

*BROKERS: McGrath Yachts (510) 521-5020 • Orange Coast Yachts (510) 523-2628*

*Richard Boland Yacht Sales (510) 521-6213*

**More new & pre-owned boats in one location – come see!**

**MARINA VILLAGE YACHT HARBOR**  
**(510) 521-0905 • [www.marinavillageharbor.com](http://www.marinavillageharbor.com)**



# THINK

*Just say no to boxy dodgers!*

**BEFORE:**  
The Box



**AFTER:**  
Beyond  
the Box

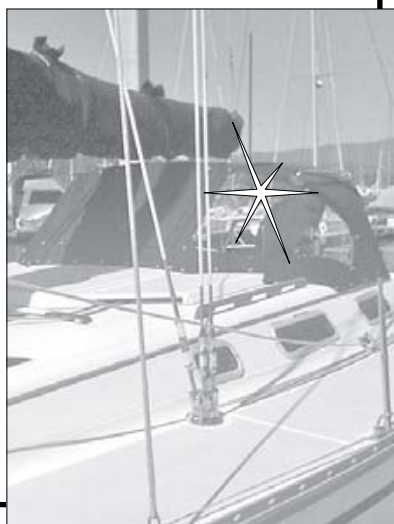

**STARBUCK**



**CANVAS WORKS**

67 Liberty Ship Way  
Sausalito, CA 94965

**415•332•2509**

# LETTERS

you realize, but you'll be impressed. When you buy the iPhone at an Apple store or Best Buy, you put a credit card number on file with Apple and set up a password in order to buy music and apps. When you want to put an app or some music or a video on your iPhone, you simply go to the 'App Store' icon on your iPhone, and select what you want. If the app or music is free, you just hit 'Install' and, as long as you have a WiFi or 3G connection, it immediately downloads. If an app costs money — the Navionics programs are \$9.99 for each huge area — you click 'Install' and the cost is automatically put on your credit card and a receipt is emailed to you. It's remarkably quick, easy and seamless, so there is none of that rubbish about going to a store to buy an app. Apps take anywhere from a few seconds to about 10 minutes to download, and it can be done while eating at a restaurant, driving your car or sleeping — as long as you have an internet connection.

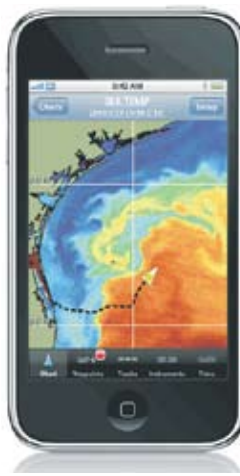

COURTESY FUGAWI

**The iNavX software allows sailors to view charts, GRIB files and AIS targets.**

The Chronicle did a piece on iPhone navigation apps recently and mentioned that Philippe Kahn used an iPhone to help him navigate in last year's race to Hawaii. One

reader responded that sure, it was great for Kahn, a guy who can afford to pay for being connected to the internet all the way across the ocean. He missed the point. The latest iPhones have an internal GPS, and the Navionics charts are stored in the phone itself, so you don't need an internet connection to use the navigation programs. It's pretty slick.

If you haven't used an iPhone, you will be astonished by all it can do using the various apps. But also be aware that the small screen means that it does have some visual limitations. That being the case, unless we were on an extreme budget, we would not carry it as our only navigation aid.

Have fun in Alaska — don't forget to email some photos.

## ↑↓ MARINE FORECASTS NEED IMPROVEMENT

Isn't it time that we did something about the shoddy marine forecasts for San Francisco Bay? For instance, on the afternoon of November 28, the forecast called for 15 knots dropping to 12 knots. It actually blew 44 knots. It's not as if this surprised anyone who knows anything about weather systems. For example, the local media and *weather.com* had predicted a big blow.

I wouldn't be complaining but for the fact that my class, the Finns, had a regatta that weekend on the Berkeley Circle. One competitor based his decision to sail from Alameda to Berkeley on the basis of the benign and completely misleading marine forecast. He didn't hit the worst of it until he was north of the Bay Bridge, by which time it was a toss-up whether he should continue on or sail back home. It's downright dangerous in a singlehanded dinghy when it's blowing Force 8 and nobody else is around. Three other Finns set out to the course from Belvedere. One skipper actually made it to the Berkeley Marina, while two fetched up on Treasure Island for the night.

I'm curious how many of your readers' safety has been impaired by negligent marine forecasts?

Iain Woolward  
Redwood City

**HONDA MARINE**  
IT'S ALL ABOUT POWER.

**caribe**  
INFLATABLES

**Aquapro**  
INFLATABLES

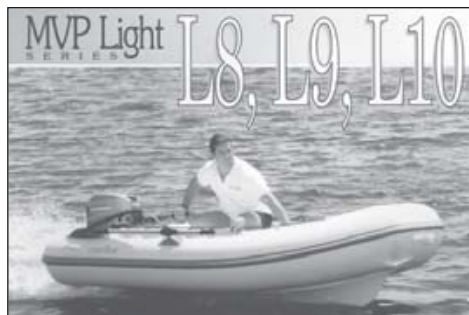

**HONDA MARINE**  
IT'S ALL ABOUT POWER.

**TOHATSU**  
outboards

**Achilles**

We've been THE Bay Area authority for  
inflatables and outboards for more than 35 years.

Call us today for quotes.

**Voyager Marine**

1296 State St.  
P.O. Box 246, Alviso, CA 95002-0246  
**(408) 263-7633 • (800) 700-7633**  
Open Tuesday thru Saturday



# COME VISIT COYOTE POINT MARINA:

*The Peninsula's Complete Recreational Destination!*



**Multihull  
side ties available  
up to 40 ft.**

## **BERTHING**

- Slips to 40' available
- Inside ties from \$85 per mo.
- Multihull side ties available
- Check out our rates!



## **FUEL DOCK & PUMP OUT**

- Open 7 days per week
- Gas and diesel available
- Check our prices
- Free pump outs



## **COYOTE POINT RECREATIONAL AREA – HOME TO:**

- Coyote Point Marina
- Poplar Creek Golf Course
- Coyote Point Park
- Captain's House Conference Center
- Beach, Picnic & BBQ Areas
- Coyote Point Yacht Club
- Dominic's Restaurant
- Magic Mountain Playground
- Coyote Point Museum
- Shoreline Trail

**COME FOR A VISIT – WE THINK YOU'LL STAY**

*Call us and mention this ad for a FREE Weekend Guest Berth*

**COYOTE POINT MARINA ~ 1900 Coyote Point Drive • San Mateo**

**650.573.2594**

# Boom Boon



## Wichard Gyb'easy Boom Brake

An out-of-control boom can bring a great day to a crashing end. So all kinds of clever inventors have created all kinds of clever gizmos to prevent a runaway boom from slamming across the boat. Trouble is, they were often more trouble to use than the trouble they were designed to prevent. Which is why we think the Gyb'easy is so brilliant. It's a simple device that's simple to use, and it WORKS! Significantly less expensive than a new boom—or a new head!

 **West Marine**<sup>®</sup>

We have 17 stores in Northern California,  
including our Alameda Sailing Superstore!

Log onto [westmarine.com](http://westmarine.com) to find the store nearest you.

## LETTERS

*Iain — It would be interesting to know why the National Weather Service's forecast was apparently so different from that given by media outlets. After all, everybody relies on the same raw data. We find it hard to believe that even different computer models would come up with such differing forecasts.*

### ↑↓SASHIMI AND FORECASTS SHOULD BE FRESH

Ya'll asked if the weather forecasts should be better? Hell, yes! And not just on the West Coast either. Three weeks ago, I left Reedville, Virginia, aboard my Coronado 30. I did this because four days earlier the NWS marine report said there would be 1- to 3-ft seas, building to 2-3 feet later that evening. The winds were to be 5-10 knots, building to 10-15 knots that night.

But when I got out on Chesapeake Bay, the wind was 20-25 knots and the steep seas were four feet and building on my port quarter. I lost my engine, then my mainsail got stuck halfway up the mast because a broken car twisted in the track. Unable to let the tiller go to get to the mast, I was set on my beam ends twice before I managed to find a place to drop the hook. For the next three days I rode out a Nor'easter on the Chesapeake. I did gain a lot of faith in 35-lb CQR, which didn't drag in winds of 35-45 mph.

So yes, forecasts need to improve because they are more than just an inconvenience, they are darn right life-threatening!

Bill Leggett  
Pretty Lucky, Coronado 30  
Reedville, VA

*Bill — Relying on a four-day old marine forecast is like eating sashimi that's been sitting in a display case for four days — it should be avoided at all costs. After three days and sometimes even two, the accuracy of weather forecasts rapidly deteriorates.*

### ↑↓THE FORECAST IS ALWAYS FOR LIGHT WINDS

I fully concur with Iain Woolward's opinion that National Weather Service forecasts are not only highly inaccurate, but dangerous to anyone who needs accurate forecasting for planning purposes. Based on my experience, no matter how powerful the approaching system may be, the forecast is always for light winds — even just a day in advance of the forecast period.

As I recall, the NWS missed a nearly identical situation November 28 last year, when a Norther that hadn't been forecast resulted in high winds. As a result, boatowners found themselves in unexpected emergencies. Yet wind forecasting is the best understood and forecastable weather phenomenon. It should be accurately disseminated at least 24 hours ahead of the forecast period.

I understand that the federal government, in its drive to automate weather forecasting, relies heavily on two forecasting computer models that are obviously inadequate for the job. This, coupled with the closing of many local meteorological offices, and the reduction of experienced staff meteorologists, means that there is no oversight to catch these erroneous forecasts.

Winds for storms approaching the San Francisco Bay Area are almost always underestimated days before the system's arrival. Cold fronts typically advance at around 25 knots, yet the forecasts almost always predict 5-15 knots for the event. Richardson Bay and Pt. Blunt routinely experience 40-60 knots during these same storms.

Computer models alone are not the answer. We need more



# Choosing a bottom paint just got easier!

*You can pick old technology...*



## *...or Micron® Technology.*

***A compass works, a GPS works better. Old bottom paint works, Micron Extra works better!***

Unlike traditional high copper bottom paint, Micron Extra is engineered for California. It uses less copper more efficiently, providing many seasons of hassle free boating.

Micron Technology is a controlled polishing breakthrough that delivers a smoother more fuel efficient surface and the long-lasting antifouling protection that you expect.

Old technology bottom paints continue to build up and crater over time, but there is no build up with Micron Extra, so you will never spend money to remove it.

If you are not using Micron Technology, you are using old technology. It is that simple.

**Do yourself, your boat, and the environment a favor, choose Micron Extra.**



Our World is Water

Visit our website for more information: [yachtpaint.com](http://yachtpaint.com)

 Interlux®, Micron® and Biolux® are registered trademarks of Akzo Nobel.

# Line Items



## Upgrade Now—Enjoy Better Performance this Spring!

It's really very simple, aboard a sailboat stretch means wasted energy. This applies to sails and to the lines you use to control them. So if you'd like to put more of the wind's energy into moving your boat through the water, consider upgrading the cordage aboard your boat.

West Marine has the latest advanced-technology lines from New England Ropes, Samson and FSE Robline. Visit our Rigging Shop in Alameda and talk to our experts about which lines and sizes are most appropriate to upgrade the performance of your boat.

Low-stretch rope makes a difference you'll notice. And we're not just handing you a line.

 **West Marine**®

We have 17 stores in Northern California,  
including our Alameda Sailing Superstore!

Log onto [westmarine.com](http://westmarine.com) to find the store nearest you.

## LETTERS

experienced meteorologists to backstop this imperfect automation. Could the couple lost while fishing near Bodega Bay recently and the sailor lost from *Sunyata* near Half Moon Bay been saved by more accurate forecasting?

Steve Knight  
Wandering Star, Islander 37  
San Francisco

*Steve — We're surprised that you and so many other readers seem to think that forecasts can be so easily be improved, as if it were a matter of just buying more computers or getting lazy-ass*



LATITUDE / JOHN A.

*If the Bay looked like this during a winter storm, imagine what the ocean was like.*

*meteorologists off their duffs. Has it ever occurred to you that maybe there are technical limitations? If getting technical progress were as simple as wishing for it, we'd all be driving cars that got 100 mph from a drop of saltwater, cancer*

*would be a thing of the past, and we'd be travelling the world via teleportation. We'll bet you a quarter that the computers and modeling programs needed for the kind of accurate forecasts you want don't exist yet — and won't anytime soon.*

*We don't think the closing of meteorological offices has much to do with the problems of inaccurate weather forecasts. After all, everybody has access to all the raw weather data, and there are countless free weather sites on the internet where professional and amateur forecasters have gone over what the NWS computers have put out. The truth is that, in general, weather forecasting is far superior to what it was only five years ago.*

*Perhaps the thing the NWS does worst is fail to inform the public of how inaccurate their forecasts can be and why. And maybe there should be more warnings about the dangers of being off the coast of Northern California in the winter. Unless you have to be out there, or unless the conditions are ideal, we think pleasure sailors and fishermen are better off staying inside the Bay. We don't even need to refer to hard data to know that the rate of mariner deaths outside the Gate soars during the winter months. Please, please, please be careful out there!*

### ↑↓ A HEALTHY SKEPTIC WHO HAS ANOTHER PLAN

I can't really say that my safety has been impaired by bad weather forecasts. However, that's largely because the marine forecasts have so frequently proved to be faulty that I try always to sail with a Plan B if conditions are different than expected. This is pretty easy to do inside the Bay, but not outside the Gate.

I've written to the local television stations requesting that they expand their weather coverage to marine conditions on a more regular basis. But they don't seem to be interested. That seems odd given that we live in one of the world's prime sailing areas.

Greg Thornton  
Refuge, Catalina 36  
San Francisco Bay

*Greg — Having a Plan B — and maybe a Plan C — is always wise, especially in the winter.*

# THE FINEST SAILS BEGIN WITH THE BEST SAILCLOTH

Our patented woven Vectran® sailcloth performs like the laminates with the durability of Dacron®, especially in roller furling applications. In fact, Vectran® is lighter, lower stretch, and retains its shape over a longer life than any sailcloth we've ever offered to cruising sailors. That's because Hood Vectran® is woven, not laminated to Mylar® film. And you can be sure that each sail we roll out is built by hand, with the same care and craftsmanship that has been the Hood hallmark for 50 years. To discuss your sailcloth needs – whether our state-of-the-art Vectran® or our soft, tight-weave Dacron® – give us a call today.

**HOOD Sails & Service**

**HOOD New Sails**

**HOOD Sail Repairs**

**HOOD Furling Conversions**

**HOOD Pickup & Delivery**



**SAILMAKERS**

**Outbound Yachts  
New Outbound 52  
with Hood Vektron  
Vertical Full Batten  
In-Mast Furling  
Mainsail and 135%  
Vektron Genoa**

**PHOTO COURTESY  
SWIFTSURE YACHTS**

**HOOD SAILMAKERS 466 Coloma Street, Sausalito, CA 94965**

**Call Robin Sodaro (800) 883-7245 (415) 332-4104 Fax (415) 332-0943 hoodsails@aol.com**

**Visit our website for Special Online Discount Pricing... [www.hoodsailmakers.com](http://www.hoodsailmakers.com)**

# Carbo Loading!



## **HARKEN** Carbo AirBlocks

Where do you want to spend your energy? That's really the question you need to ask yourself when you consider how your boat is rigged. So consider this: Weight wastes wind energy, Friction wastes your (and your crew's) energy.

Fortunately, Harken has addressed both weight and friction in their comprehensive line of Carbo Airblocks. They're lightweight, free-running, strong, reliable and—get this—affordable! Now's a perfect time to scrutinize your boat's controls and replace those heavy, balky old-style blocks. Load your boat with a full complement of Carbo Airblocks and, when Spring springs, you, your crew and your whole boat will be able to tap into the energy that used to vanish into thin air.

 **West Marine**<sup>®</sup>

We have 17 stores in Northern California,  
including our Alameda Sailing Superstore!

Log onto [westmarine.com](http://westmarine.com) to find the store nearest you.

## LETTERS

### ↑↓ALWAYS GET A SECOND OPINION

I always use a few sites to verify weather conditions and forecasts. NOAA always seems to be a little conservative, as I usually find that conditions are more gentle than they forecast.

Using the regular sources of weather information, I was aware of all the big blows that hit last year. I have never been surprised by bad conditions.

Gary Scheier  
*Serenisea II*, Hunter 37  
San Rafael

### ↑↓REAL TIME WEATHER FOR THE BAY IS AVAILABLE

No offense to my friend and fellow Finn sailor Iain Woolward, but my safety on the water has never been impaired by anything other than my own poor judgment or lack of ability. I think Iain needs to re-read Rule 4: "The responsibility for a boat's decision to participate in a race or to continue racing is hers alone." At the risk of sounding harsh, blaming one's situation on a bad weather forecast is shirking your responsibility as the skipper.

Real-time weather information for San Francisco Bay is readily available online through sources such as the National Buoy Data Center ([www.ndbc.noaa.gov](http://www.ndbc.noaa.gov)), [SailFlow.com](http://SailFlow.com), [iWindsurf.com](http://iWindsurf.com), Real Time S.F. Bay Wind Patterns ([www.sfsports.wr.usgs.gov/wind](http://www.sfsports.wr.usgs.gov/wind)), and a few yacht club websites. Heck, making a couple of phone calls or sending a couple of emails can also get you the information you need. As a last resort, I'll even take a short drive to check things out before I launch my Finn in conditions exceeding my ability — and it doesn't take much to do that. If you're out by yourself, it might be prudent to stuff a handheld VHF and a pair of flares into the flotation tanks.

Lastly, using the term "negligence" in regard to weather forecasts is probably ill-advised, given that it is a legal term connoting blame, and therefore damages to an injured party. I dare say that it would be nigh on impossible to prove negligence against a weather forecaster.

Nick Salvador  
Finn, USA 1109  
Richmond

*Nick — This is America, where every victim of misfortune/poor judgment usually tries to find somebody — hopefully backed by the taxpayer money — to pay big damages. We quote an Associated Press story out of Washington, D.C.: "A judge's ruling that the National Weather Service must pay the families of men lost in a storm it didn't predict has given some meteorologists the chills. The award of \$1.25 million to the families of three lobstermen in Boston last week was the first ruling against the weather service in the memory of many meteorologists."*

*Granted, this story was from the '80s and the judgment may have been overturned on appeal, but never say never when it comes to other people trying to put the blame on somebody else.*

### ↑↓WAS THAT A PUBLICITY STUNT OR SOMETHING?

With regard to the November 30 *Lectronic* item *On The Tasman Sea*, in which it was reported that German singlehander Bernt Luchtenborg had to be rescued by the 700-ft *Regent Seven Seas Mariner* during what had been his attempt to do a twice-around non-stop circumnavigation, I'm thinking that there might be more or less to the story than was reported.

To me, it seemed like an advertisement for the German

# Offshore Adventure Sailing

## What we do best



**LEG 1 - Newport Beach to Easter Island**  
24 days 3800 mi. Oct 30 - Nov 23, 2010  
Fantastic open ocean sailing, an equator crossing and landfall in the world's most remote inhabited island.

**LEG 2 - Easter Island - Puerto Montt, Chile**  
19 days 2500 mi. Nov 24 - Dec 12, 2010  
Primal Moai statues make a dramatic backdrop as *Eagle* sails into the southeast trades toward Chile. There will be plenty of time to practice celestial and other traditional sailing skills.

**LEG 3 - Puerto Montt, Ushuaia, Argentina**  
23 days 1400 mi. Dec 19 - Jan 11, 2011  
This area is less traveled than Antarctica with some of the world's most spectacular scenery. Conditions are varied with literally sun and snow on the same day. Days will be spent exploring the inlets where glaciers, waterfalls and snowcapped peaks are found.

**LEG 4 - Ushuaia - Cape Horn - Ushuaia, Argentina**  
10 days 300 mi. Jan 18 - Jan 28, 2011  
Covering three hundred miles in ten days sounds easy unless the itinerary is a rounding of notorious Cape Horn. While on many sailors list, this is not a trip to be taken lightly.

**LEG 5 - Ushuaia - South Georgia Island - Buenos Aires, Argentina**  
31 days 2700 mi. Feb 4 - March 7, 2011  
Extreme sailing and an exploration of a magnificent sub-Antarctic island, followed by a grueling stretch of Southern Ocean sailing to Buenos Aires.

**LEG 6 - Buenos Aires - Rio de Janeiro, Brazil**  
14 days 1200 mi. Mar 14 - Mar 28, 2011  
Stopping in Punta del Este and Rio de Janeiro, *Alaska Eagle* will be returning to two of the ports that were part of her Whitbread Racing career.

**LEG 7 - Rio de Janeiro - English Harbor, Antigua**  
28 days 3500 mi. Apr 1 - Apr 29, 2011  
Southeast trades, an equator crossing, then on to the Northeast trades! Arriving in Antigua will be the culmination of nearly a month at sea and *Alaska Eagle's* South American adventure.

The School of  
**SAILING & SEAMANSHIP**  
| Orange Coast College



**www.occsailing.com**  
**949-645-9412**  
1801 W. Coast Hwy,  
Newport Beach, CA 92663



This year's voyages are for those looking for extreme adventure. These voyages are the heart and soul of what *Alaska Eagle* was built to do: Sail extended offshore voyages to exotic destinations.

This year's applicants must have a strong sailing background, be in excellent physical condition and have a highly honed sense of adventure.

**ALASKA EAGLE**

# Crank Call!



**TITAN**

to make the world's best-selling winch handles, right? Well here they are!

Titan's Primary Floating Winch handle is number one for some very compelling reasons. First, of course, is that this handle works really well. It's strong, lightweight and the handle spins freely so more of your energy goes into turning the winch. But what really launched these handles is what happens when the handles get launched (over the side, that is). They float! So now you won't have to watch dollars fly out of your wallet as your expensive winch handle sinks like a stone.

So next time you watch a dropped handle sink out of sight, don't get cranky. Drop by West Marine and pick up a set of Titan Floating Winch Handles!

**West Marine**

We have 17 stores in Northern California, including our Alameda Sailing Superstore!

Log onto [westmarine.com](http://westmarine.com) to find the store nearest you.

## LETTERS

singlehander and the cruise ship. Plus, the photo with the article didn't match the ocean or sea state that was described. Also, what was your reporter doing that allowed her to be on



SUSAN ATKINS

**This was no publicity stunt. After diverting 300 miles off-course to go to the aid of singlehander Bernt Lüchtenborg, a RIB from the 700-ft all-suite 'Regent Seven Seas Mariner' bashed its way to the disabled Glacier 52 'Horizons' in 20-ft seas.**

sailing from Point A to Point B.

the bridge listening to privileged information?

I've sailed the Tasman, and have seen classic water-skiing conditions. I've also seen her when it was blowing 70 knots. The weather I saw depicted by the photograph was not catastrophic, instead it was weather sailors long for when

Robbin Bryson  
Robbin's Nest, Santana "21"  
Sacramento

Robbin — Let us answer your questions in reverse order, as it may make more sense. First, Kevin LaGraff and Susan Atkins of Sausalito, our 'reporters', are friends of many years from a swim club. The last time they wrote was after a similar incident off the Cape of Good Hope. For years they've worked in the travel industry in some capacity that allows them to spend much of the year on cruise ships. They are the kind of responsible and reliable people — Kevin graduated from the Naval Academy — who are very good at what they do.

It doesn't surprise us that Susan was allowed on the bridge, as most cruise lines find it valuable to share the mystique of the bridge with certain guests. What "privileged information"



KEVIN LAGRAFF

**Lüchtenborg graciously poses with Susan Atkins aboard 'Regent Seven Seas'.**

are you referring to? It's not as if there was any attorney-client or doctor-patient relationship. Susan apparently just struck up a conversation with Lüchtenborg after he was rescued. Why not? As anyone who has taken photographs of rough weather can tell you, the foreshortening effect of the lens makes the conditions look only half as bad as they really are. We're sure Lüchtenborg would not have called for help had his rudder not been damaged beyond repair, and that neither he nor the cruise line was fishing for any publicity. We're certain that it was a straightforward and legitimate story.

↑↓ **OUTBOARDS ARE GREAT BUT . . .**

I'm writing mostly in reply to Bill Murphy, who wrote



*GREAT GEAR*

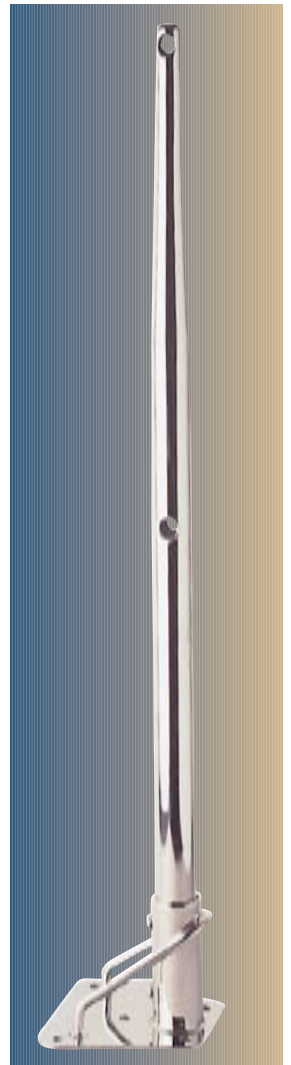

**Quality stanchions and gates from Garhauer**

**W**hether you are replacing one stanchion or upgrading your entire boat, we manufacture a complete line of stanchions, bases and gates.

- Stanchion tubes available in 3 different tip styles
- Stanchions and gates can be made removable or with fixed bases.



1082 West Ninth Street,  
Upland, California 91786

Phone: (909) 985-9993  
FAX: (909) 946-3913

email: [garhauer@garhauermarine.com](mailto:garhauer@garhauermarine.com)  
<http://www.garhauermarine.com>



# Ullman Sails

An Investment in Performance

## New Year's Resolution #1

**"Spend more time sailing/racing with friends."**

Statistically **80%** of you will **fail** to achieve your New Year's Resolution!

**Ullman Sails** delivers the **greatest success rate** assisting customers achieve their New Year's Resolution.

Contact your local Ullman Sails loft or Representative to assist you in your 2010 Sailing Goals.

Please contact your local loft or representative today for pricing and sail specials.

**Have you heard about our Winter Sailing Seminars?**  
Visit [www.ullmansailsnewportbeach.com](http://www.ullmansailsnewportbeach.com) for details

### PLEASE CONTACT A LOFT LISTED BELOW FOR PRICING AND DETAILS

#### Newport Beach

(714) 432-1860  
2710 S. Croddy Way  
Santa Ana, CA 92704  
Dave Ullman  
Bruce Cooper  
Steve Beck  
Erik Shampain  
**Marina del Rey/  
King Harbor**  
Mike George  
(310) 645-0196  
Steve Beck  
(562) 243-9710

#### Long Beach

(562) 598-9441  
6400 Marina Drive #9  
Long Beach, CA  
90803  
Bryan Dair  
Steve Beck  
(562) 243-9710  
**Ventura**  
(805) 644-9579  
3639 E. Harbor Blvd.  
#111  
Ventura, CA 93001  
Gary Swenson  
Deke Klatt

#### Santa Barbara

Ken Kieding  
(805) 965-4538  
Gary Swenson  
(805) 644-9579  
**Santa Cruz**  
Brent Ruhne  
Ruhne Racing  
(831) 295-8290 mobile  
**San Francisco/  
Sausalito**  
(Racing Sails Only)  
Robin Sodaro  
466 Coloma St.  
Sausalito, CA 94965  
(415) 332-4117



Visit our website:  
[www.ullmansails.com](http://www.ullmansails.com)

## LETTERS

asking what outboard to use to power his Newport 27. I've owned seven different outboard-powered sailboats from 21 to 28 feet. I currently have an Excalibur 26 that is powered by a Johnson Sailstar two-cycle, 8-hp with an extra-long shaft. Here is my advice:

1) I have seen a number of Newport 27s that are powered by outboards, so I know it will work. But getting the outboard bracket positioned just right is crucial. It needs to be down far enough to keep the shaft in the water, but not so far down that it's impossible to access without hanging off your boat by your ankles.

2) Many boatowners buy more engine than they need. For a Newport 27, I'd go with an 8-hp Honda — with the longest shaft they make.

3) If you're going to keep your fuel can belowdecks, make sure you have adequate ventilation so fumes don't accumulate.

4) The extra weight and cost of a four-cycle outboard are worth the tradeoff in terms of better mileage and a better environment.

5) If you are going to be taking the motor off a lot, invest in a lifting harness made from nylon webbing.

In my opinion, the tradeoffs involved with an outboard-powered sailboat are generally worth it. For one thing, the cost of a new or nearly new outboard, plus a good bracket, is less than half the cost of a rebuilt Atomic 4 gas engine. But make no mistake, there is definitely a tradeoff involved. While you get lower initial cost and lower maintenance costs, you definitely give up a considerable amount of convenience and efficiency in the process. When it's windy and choppy, and you have to lower the outboard and start it, you might wish you'd spent the money to have your inboard engine rebuilt.

Alan F. Shirek  
Tao, Excalibur 26  
Santa Barbara

### ↑↓A DINGHY-POWERED CAL 36

Regarding Bill Murphy's seeking advice on the proper outboard for his Newport 27, when my *Eupsychia* was engineless — as she was for much of last year's cruise in Mexico — and



LATITUDE / RICHARD

the wind failed us, Heather and I would tie my outboard-powered dinghy alongside. Pushed by the dinghy powered by an 8-hp outboard, my 15,000-lb Cal 36 would easily do five knots around the harbor. Just about any boat will move right

along powered by a small engine — until the wind is on the nose or it gets choppy. In such conditions not even *Eupsychia's* new 20-hp diesel is adequate.

P.S. The Banderas Bay Blast was really great. Thanks for the picture of *Eupsychia* in the *Lectronic* feature, as my family appreciates your efforts to keep them informed of my otherwise unknown life.

David Addleman  
*Eupsychia*, Cal 36  
Monterey



Get Pacific Cup Ready Now  
Best Deals Available  
Before January 31!



## Four Reasons You'll Go Fast and Stay Fast.

STRATIS is the latest in advanced sail technology from Doyle Sailmakers.

- **EASIER TO TRIM.** Doyle's 3-dimensional fiber-mapping program precisely aligns STRATIS fibers according to wind and stress loads.
- **FASTER.** The same sail designers that bring Olympians and World Champions their sails are behind every STRATIS design.
- **LIGHTER.** Doyle's unique pre-preg fiber and film lamination process precisely controls the amount of adhesive in each STRATIS sail.
- **MORE DURABLE.** STRATIS precision lamination

means strength; STRATIS yarn-laying precision means effective shape-holding across the wind range. The combination adds up to durability. For the full story on STRATIS custom made load-path racing and cruising sails, visit [www.doylesails.com](http://www.doylesails.com)

Or contact your local Doyle loft today!

### Doyle San Francisco

2035 Clement Ave.  
Alameda, CA 94501

Tel: 510-523-9411

E-mail: [sanfrancisco@doylesails.com](mailto:sanfrancisco@doylesails.com)

[www.doylesails.com](http://www.doylesails.com)



1-800-94-DOYLE

BETTER ENGINEERED SAILS





# LEISURE FURL® BROUGHT BACK THE FUN OF SAILING

Over 4000  
In Use Worldwide



"The big main on our prior boat, a Sabre 42, was too much for my wife Kathy and I to handle, so we had a Leisure Furl boom installed. The ease of handling our main reignited our love of sailing. It eliminated the stress associated with reefing and dousing the big main.

With our new confidence we bought a bigger boat anticipating retirement and more time on the water. Being able to furl the main from the cockpit keeps us in control and safe. Thanks to our Leisure Furl boom we have cruised to new places and met new friends."

Emmett & Kathy Hartly  
Hinckley So'Wester 51 - REGULUS

Come see **Jim Plumley**  
J.P. Boatworks

Northern California's #1 Leisure Furl Distributor  
Sausalito • 415.331.3277



JUST ONE OF OUR  
MANY PRODUCT LINES

www.forespar.com  
Ph: 949.858.8820 • Fax: 949.858.0505

## LETTERS

Readers — Feeling the need for more speed than provided by the Cal 36 that has been in the family for something like 40 years, David is currently in Malaysia trying to close a deal on a cruising version of a Santa Cruz 50. An ultralight, it will power very nicely.

### ↑↓ THE WHENS AND WHEREFORES OF GETTING A TIP

Thanks for all your work in pulling off the '09 Ha-Ha. But we have a paperwork snafu. We arrived on November 5, and like a lot of people, paid to have Charters de Los Cabos do our paperwork. A delivery captain is now bringing the boat back to California, and he's looking for a Temporary Import Permit. We didn't get one back from Charters de Los Cabos. But I have an embarrassing question. Do we need this permit if we're coming right home?

By the way, it was our first Ha-Ha and we had a great time. We were impressed by your organization and effort. I also admire your patience in dealing with questions. We look forward to seeing you next year.

Jim Schmid  
Formula Won, Beneteau 473  
San Diego

James — It's a good question, and the answer to whether you need a TIP or not is that it depends on what you'll be doing with your boat. Technically, you're supposed get a TIP at your first port of entry. But that's not always possible because you have to pay the \$50 fee for a 10-year permit to a banjercito — which is a military bank — and not all port of entries have banjercitos.

Temporary Import Permits were created about 15 years ago because, prior to that, there was no legal way for the owner of a foreign boat to leave Mexico without taking his boat with him. So if you were in Puerto Vallarta with your boat and wanted to return to California for your kid's birthday, the only legal way to do it was to take your boat with you. Everybody returned home without their boats anyway, and officials never did anything about it. But ultimately the government decided to create a mechanism — Temporary Import Permits — to allow boat owners to legally leave their boats in Mexico while they returned home. A TIP basically makes a marina responsible for your boat while you are gone. That's why most marinas will insist on seeing your Temporary Import Permit when you check in.

If, as in your case, a person brought his boat down to Cabo and immediately returned to the States, there is no need to get a TIP. Indeed, if you're never going to stay in a marina, you can probably get away without one also. But if you're in Mexico for more than a few months, things could get sticky. We think getting a TIP is \$50 well spent.

### ↑↓ AN UPDATE ON TIPS FROM FORMULA WON

When I wrote you a month ago with my "embarrassing question" — did we need to get a Temporary Import Permit (TIP) if we had our boat delivered back to California right after the Ha-Ha? — I promised you a summary of the answers we received on the question:

- 1) From our delivery captain: Yes, our boat needed one.
- 2) Source #1 at Charters de los Cabos, where most Ha-Ha boats checked into Mexico: You have to go to La Paz to get a TIP.
- 3) Source #2 at Charters de los Cabos: You don't need one if you are staying in Mexico less than two months.
- 4) The Mexican Customs office: You need to get a TIP. If your boat is stopped and you don't have one, your boat could

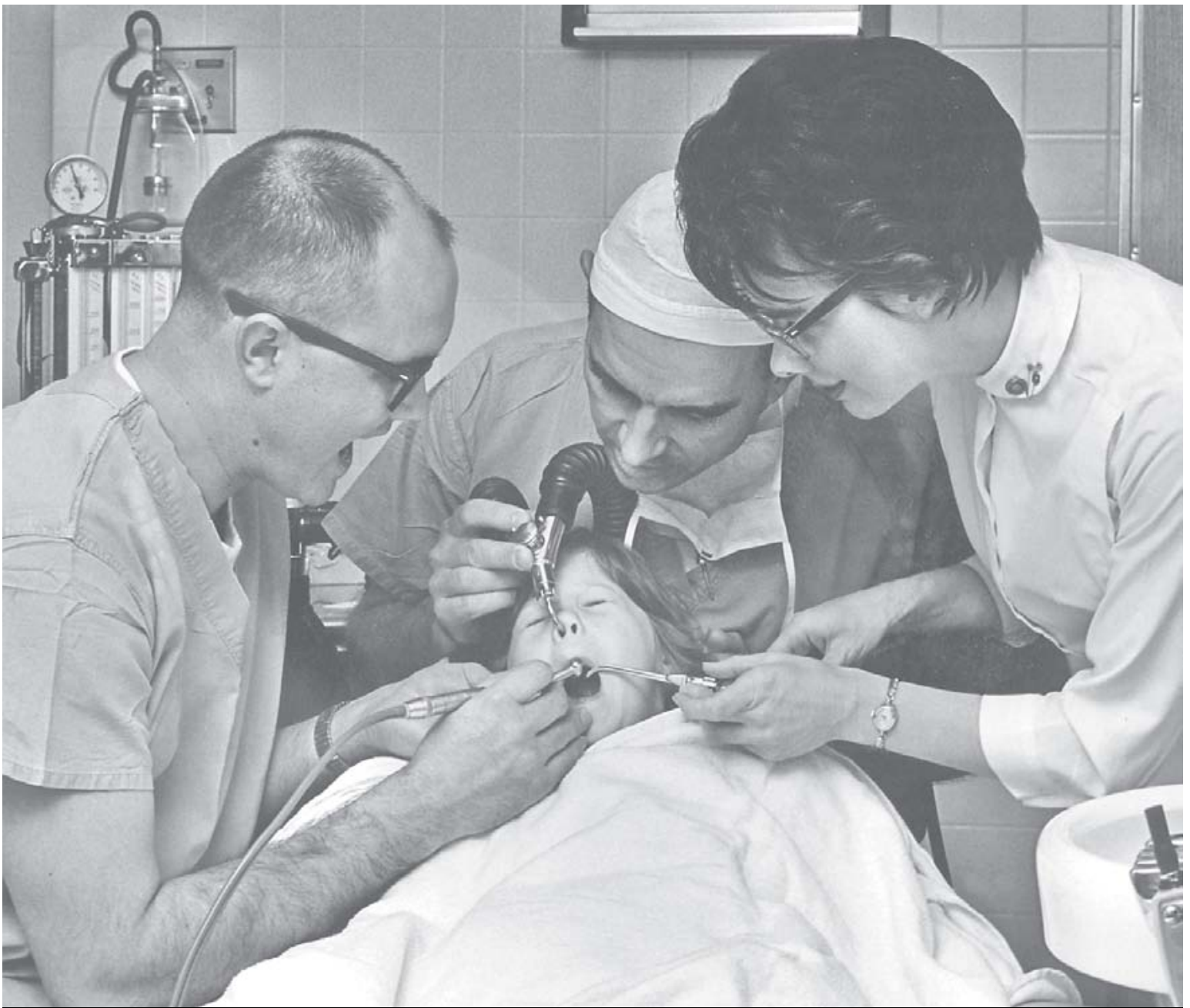

## Remind you of getting your sailboat serviced?

Let's face it, getting your sailboat serviced can be a painful experience. Which is why we do all we can to eliminate nasty surprises. We'll quote you a price up front, and we'll stick to it. We're Bay Marine Boatworks—the full-service boatyard. From bottom painting to complex fiberglass repair work, you will find we can handle all your sailboat maintenance and repair needs.

And this month, our new management is offering a free haul-out with every bottom job. This time, come to Bay Marine Boatworks, where your sailboat service won't feel like a root canal.

**BAY MARINE**  
**BOATWORKS Inc.**  
*The Sailor's Boatyard*



310 W. Cutting Blvd.  
Pt. Richmond, CA  
1-800-900-6646

---

## LETTERS

be impounded.

5) The Marina Agency in Ensenada: You don't need one if you're just going back to the States.

6) From the internet: You can get a TIP over the internet, but you have to get it signed at a government office in Mexico.

7) From an experienced skipper: "I've never gotten a TIP for a boat I was on, and have never been asked to produce one — except at U.S. Customs. I told them I didn't have one, and there was no problem."

8) From another source: You don't need one unless you stop in a city that has a *banjercito* that issues them.

9) We tried to talk with the Mexican Consulate about the subject, but it was closed on U.S. Veterans Day for reasons that I didn't bother to pursue.

Other than that, the rules were clear.

When we received *Latitude's* advice on the subject — don't bother getting a TIP if our boat was going right back to the States — we followed it. *Formula Won* motored back to the United States without incident.

Jim Schmid  
*Formula Won*, Beneteau 473  
San Diego

*Jim — We're glad our advice worked out for you. Had you been planning to keep your boat in Mexico for more than a few months, or put her in a marina, we would have certainly recommended getting a TIP.*

*But just for the record, Mexico is doing a much better job of keeping track of things than they used to. J.R. — a great guy, sailor, and longtime member of the Vallarta YC — recently told us that he was unable to bring a motorhome into Mexico last year. The problem was that their records showed that he'd already brought in the one vehicle he was allowed about eight years before. J.R. was stunned that they'd been able to keep track and call up the record, and so were we. The message is that boat owners aren't going to be able to play quite as fast and loose with the regulations as in the past.*

### ↑↓ BOATS NEED TO COME WITH BETTER BILGE PUMPS

The seven-minute sinking of *J World* in the Ha-Ha brings to mind the grossly inadequate dewatering capabilities of most production boats. The usual equipment is a low-volume electrical pump and a slightly higher-volume hand pump.

The intake of water after losing a rudder and its shaft — assuming that's what happened to *J World* — or losing virtually any rubber hose fitting on such boats, cannot be managed by the factory-equipped pumps. The boat will sink in time. In order to enter any offshore event, I think boats should be required to have a *real* dewatering system so that repairs can be made to save the boat.

For example, in addition to two high-capacity manual pumps and one high-capacity electrical pump, we also have configured our two Lavac heads — which use Whale-brand manual pumps — to source water from the bilge rather than the ocean should the situation ever get that serious. Of course, we would then need four different people to pump, but that might be better than four people having to get into a liferaft.

It's time that production sailboat builders be required to supply pumps that can keep up with a 1.5 to 2-inch hole in their boats.

Scott Brear  
Samantha, Nauticat 38  
San Francisco



**To-DO List:  
Boat Projects**

- Build Spinnaker
- Replenish Repair Kit
- Sew New Fender Covers
- Replace Bimini Zippers
- New Cockpit Cushions
- Get ATN Tacker
- Replace Genoa Sheets
- New Strataglass  
Dodger Windows

**Shop Sailrite**

**Sailrite**

[www.sailrite.com](http://www.sailrite.com)

Free Catalog • 800.348.2769 • 260.693.2242

# Time to move?



Worth a look at  
[www.MarinaBayYachtHarbor.com](http://www.MarinaBayYachtHarbor.com)  
Tour our photo gallery and then come visit...

# MORE SAVINGS! MORE SAILING!

Pay on the first day of the month for a charter: **\$245**

Sail a second day: **No Charge!**

A third day: **No Charge!**

Fourth day: **No Charge!**

Fifth day or more: **No Charge!**

---

Grand Total: **\$245**

How do you like our math?!

At *Tradewinds*,  
More really means More!

Yes/No	
<input type="checkbox"/> <input type="checkbox"/>	Would you sail more days per month if they were free?
<input type="checkbox"/> <input type="checkbox"/>	Would you like a wide variety of boats to choose from?
<input type="checkbox"/> <input type="checkbox"/>	Would you like to have others to sail with?

The best kept secret on The San Francisco Bay is no longer a secret at all!

Call us for details! (510) 232-7999  
www.TradewindsSailing.com

\*One year contract required.



## LETTERS

Scott — The report that it took only seven minutes for J World to sink was the result of an early misunderstanding between Capt. Eugenie Russell and Wayne Zittel, the owner of the boat. The boat actually took 45 minutes to sink.

Your understanding of the damage to the boat is also incorrect. The rudder and rudder shaft were driven up and aft, creating something like an 8-inch by 14-inch hole in the very aft bottom and transom of the boat. While the captain and crew battled to limit the inflow of water by plugging the hole the best they could, and by raising the transom as high and as often as possible, we doubt that your four pumps would have bought them much more time. A boat with that big a hole in those kinds of conditions wasn't going to last long.

All boats have to be built to certain Coast Guard standards. If the Coast Guard thought more or larger pumps would be helpful, we can only assume that they would require them. After all, the cost would be slight compared to the overall cost of the boat.

Major boat leaks are usually caused by thru-hull hoses breaking or coming off, and problems with prop shafts. The bilge pumps on most boats provide enough time to find the source of the leak and stop it. But when you're talking about leaks caused by relatively large holes in a boat's hull, then even the biggest engine-driven bilge pumps probably wouldn't be up to the job.

By way, if you're particularly concerned about your ability to dewater your boat in an emergency, you might want to modify the raw water intake on your engine. If the need arose, you could then use your main engine as a bilge pump, sucking water out of the bilge rather than the ocean. It would give one of the people working your Lavac pumps a chance to make more calls on the radio and get the liferaft ready. But you have to make sure that your engine room bilge is clean and that you have a good strainer on the intake hose.

### ↑↓ARNIE AIN'T GOT NOTHIN' ON OUR BICEPS

After reading about J World's unfortunate encounter with a whale, I did some research on Google to find ways to keep them clear of boats. It seems the most popular way is to bang two partially submerged 2-inch steel pipes together. This was the method used to 'herd' whales out of the Delta. Maybe a reader can devise a system that makes some noise when whales are spotted, or while cruising in an area where whales are likely to be present. It appears that there have been more problems between sailboats and whales than powerboats and whales. Is it because of the engine noise?

I want to thank you and your staff once again for producing such a great publication. As I recall, a couple of years ago the publisher was going to retire or at least semi-retire and let somebody else take the reins. I guess things changed. But now that I'm looking to semi-retire, I wonder how you're able to go cruising and still be able to work. It sure sounds nice!

Dave Biron  
Big Break Marina  
The Delta

Dave — If we banged two partially-submerged pipes together every time we'd been in the vicinity of whales in the last six months, our biceps would be bigger than a weightlifter's thighs and our crew wouldn't have gotten much sleep. We're not sure if engine noise is enough to keep whales away, as even big ships have T-boned whales. But it certainly would be great for sailors — and whales — if somebody could come up with an effective 'deer whistle' for the big boys down under.

Thanks for the kind words about Latitude. Our attempt

# PERFORMANCE

the world's your Oyster



## THE WORLD'S YOUR OYSTER

From 46 to 125 feet, every yacht in the Oyster range is recognised for its striking deck saloon profile, proven performance, build quality and a host of practical seamanlike and live aboard details that make an Oyster an Oyster.

If you are considering a quality yacht, let us show you how we can, almost literally, make the world your Oyster.



# OYSTER®

DOUBLE QUEEN'S AWARD YACHT BUILDERS



SAIL | POWER | CHARTER

**Head Office: Oyster Marine Ltd** Fox's Marina Ipswich Suffolk IP2 8SA England T: +44 1473 695005 F: +44 (0) 1473 686861 E: yachts@oystermarine.com

**Oyster Marine Germany** Saseler Str. 192a 22159 Hamburg Germany T: +49 40 64400880 F: +49 40 64400882 E: yachten@oystermarine.com

**Oyster Marine USA** Newport Shipyard One Washington Street Newport RI 02840 USA T: +401 846 7400 F: +401 846 7483 E: info@oysteryachts.com

**Oyster Yachts Asia** bart.kimman@oystermarine.hk **Oyster Yachts Italy** tommy.moscatelli@oystermarine.it **Oyster Yachts Russia** alexander.markarov@oystermarine.ru

# CONFUSED ABOUT SELF-STEERING?

We manufacture the **RIGHT** windvane for **YOUR** boat.

*All serious bluewater sailors need a reliable mechanical helmsman that can take ALL the watches.*

**A windvane from Scanmar is a 24/7 workhorse at half the price of an installed under deck autopilot.**

No impossible-to-fix electronics. No need to provide amps. No maintenance!

**The more it blows the better it works.**

See us at the  
**SEATTLE BOAT SHOW**  
Concourse Space  
#2229

**THE ULTIMATE  
GREEN  
SOLUTION**

**MONITOR  
WINDVANE™**

**#1 in WINDVANES**

Rated Best Windvane in the ARC Gear Test.  
Uses the most powerful principle, servo-pendulum.  
Can be converted to emergency rudder.

**auto-helm**  
windvane

The additional rudder solution. No lines. Emergency rudder.

**Saye's Rig**

Pendulum Trimtab on main rudder. For big boats with hydraulic steering.

Visit our website at [www.selfsteer.com](http://www.selfsteer.com)

Click on Boats and Photos and check out 5,000 installation photos.

**FACTORY DIRECT**  
since 1977  
**SCANMAR**  
INTERNATIONAL

432 South 1st St. • Pt. Richmond, CA 94804  
Tel: 510 215-2010 • Fax: 510 215-5005  
Toll Free: 888 946-3826  
email: [scanmar@selfsteer.com](mailto:scanmar@selfsteer.com)

## LETTERS

to semi-retire was a resounding failure after just two weeks — not an unusual outcome for a first attempt. We did schedule an appointment with a therapist who specializes in treating workaholics but were too busy to keep the appointment. Apparently that's also not uncommon.

Thanks to relatively high speed internet access being much more prevalent, and the incredible efficiencies given away by the gods at Google, we've been able to work at as much as 70% efficiency from different parts of the sailing world. That said, the magazine still requires a monumental amount of work each month — as all our ex-wives and girlfriends will be more than happy to tell you — and Third World internet problems can be infuriating beyond belief.

As for your situation, some jobs naturally lend themselves more than others to being done over the internet. Writing, day-trading, consulting, phone sex and similar professions aren't impossible if you've got phone and internet connections. On the other hand, if you're a chef, cosmetologist, surgeon or crack dealer, you have to be physically present at your job. We wish you the best of luck in trying to semi-retire — but god help you if you don't have something to replace work to keep your mind

busy and your desires alive.

By the way, this year's cruising class has been giving Telcel's modem high marks for internet speed, access and reasonable cost. The hassle of trying to find decent WiFi or an internet cafe is history.

**Cruisers are raving about Telcel's 3G data card for Mexico.**

The downside is that high-speed internet access can be like crack for some people, so cruisers have to be very careful with their priorities.

### ↑↓ **KNUCKLE DRAGGERS CARE MORE THAN HIPPIES?**

Thanks for running my haiku in the December *Changes*. But I think you took advantage of the short form I was forced to use by your website, and responded at length to an argument I didn't have the space to make. In essence, you said Americans' access to the Mexican health care system amounts to *de facto* reciprocity for illegal aliens' use of the United States health care system. And besides, you argued, we're all global citizens, free to pick and choose among the social welfare programs offered by the various governments of the world.

Again, I say, WTF?

If enough Americans flock to Mexico to exploit its health care system as you suggest, rising demand and deeper pockets will inevitably result in higher prices. That might be mildly unfortunate for those Americans arriving late to the fiesta, but it would be catastrophic for many Mexicans who could no longer afford their country's 'affordable' health care. Rather than your encouraging this scenario, I encourage you to use your considerable editorial clout to push for reform of the system in the United States. If, as you say, our government has devolved into complete incompetency, whose fault is that? Certainly not indigent Mexicans!

By the way, you can see related effects in places such as Guatemala, where foreign money has made real estate so expensive that most Guatemalans can't afford to own desirable property in their own country.

Something's really screwy in the world when a knuckle-dragging Texan like me is apparently more concerned about

HEATHER STAPLETON DONNELL







# Berkeley Marine Center

*The yard that works for you!*

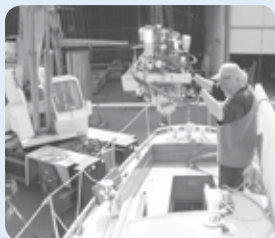

Maintenance,  
repairs &  
construction  
of yachts &  
commercial  
vessels

- Lift capacity 35 tons
- Sprayed Racing Bottoms
- Full Painting Service
- Fiberglass & Gelcoat Repairs
- Rigging Repairs & Installation
- Electrical Repairs & Installation
- Engine Service & Repowering
- Propeller Installation & Tuning
- Wood Hull Repairs & Caulking
- Teak & Non-Skid Deck Repairs

***Committed to the tradition of boating, and a tradition of customer service in everything we do.***



**Chandlery & Fuel Dock Open 7 Days**

Mon – Fri 8 to 5 • Sat & Sun 9 to 5

**In Berkeley Marina • 510-843-8195 • [www.berkeleymarine.com](http://www.berkeleymarine.com)**

# North times seven.

When performance counts the choice is clear.  
Call your nearest North Sails representative.

## Sausalito

415-339-3000

## San Rafael-Sail Care

415-453-2142

## Channel Islands

805-984-8100

## Marina Del Rey

310-827-8888

## Long Beach

562-795-5488

## Costa Mesa-Sail Care

949-645-4660

## San Diego

619-224-2424



[www.northsails.com](http://www.northsails.com)

## LETTERS

the effects of globalization on the welfare of indigenous people than you more highly-evolved folks on the Left Coast.

B.L. Sachs  
Dripping Springs, Texas

*B.L. — Sorry if we seem to have hijacked your letter. You're right, if enough Americans exploited Mexico's social security health care network, it would probably result in rising demand. But we don't think it would ever get to that point. Even if it did, we think it would result in more doctors being trained and practicing in Mexico. Better yet, if enough Americans went to Mexico to get MRIs at \$300 a crack rather than five times that in the States, wouldn't that put a powerful downward pressure on the costs of MRIs in the States? Furthermore, Mexico badly needs jobs and foreign income. If they can provide visiting and ex-pat Americans with fine health care at a huge discount to what's available in the States, why wouldn't that be good for Mexico, the patients and relieving the stress on the American medical system? When businesses compete, the customer wins. When health care systems have to compete, we think the patients win.*

*And remember, Americans seeking excellent but reasonably-priced health care don't have to tap into the Mexican social security system's health care plan. They can either pay for care out-of-pocket or by purchasing Mexican health insurance — which is inexpensive because the cost of medical care in Mexico is so inexpensive.*

*For those looking for factual costs and experiences on paying out-of-pocket annual health care check-ups, we have an example from a late middle-aged woman and late middle-aged man.*

*"I got a mammary ultrasound and a mammogram. A female assistant confirmed the results right then. I got kidney, liver, stomach, and pelvic region ultrasounds. I could see the ultrasound on the screen. I got a Papanicolaou smear test by a female assistant. My female doctor — I get the same one every year so I can have consistency — confirmed the results of all the tests right then and there. She was very thorough, too. The pap smear test came back in a couple of days. I received a written confirmation of all my tests. The total cost in April of '09 was 1,500 pesos — or about \$120 U.S. During one check-up, something was detected on my right kidney, so I was referred to a specialist. I had to wait one day to see him, but only because I had to take a test that required fasting first. I underwent a comprehensive test with frequent x-rays to monitor the progress of whatever they were running through my system. It took several hours. The actual process cost 1,800 pesos or \$144. The doctor's fee for before and after consultations was 400 pesos, or about \$32. I was also referred to a gynecologist. Her fee for two consultations, plus a bone density test, was 900 pesos or about \$72.*

*"My husband's check-up consisted of a prostate blood test, ultrasound tests for his liver, kidneys, stomach, pancreas and prostate, plus a chest x-ray, and a consultation with a urologist. It came to 1,600 pesos or \$128. He paid an extra 380 pesos or \$30 for a cholesterol test.*

*"We both felt well cared for, and liked the knowledge and networking of referrals, as well as the speed and ease of getting appointments. And even though we come from a country with nationalized health care, we found the costs to be very reasonable.*

*"By the way, when we arrived in Mexico nearly 10 years ago, we signed up for the IMSS health plan, which is the one that is part of Mexico's social security system. It cost something like \$300 a year for the two of us. But we found it to be just like*



## **MORE THAN 340 VESSEL CAPACITY (30-400 Ft)**

FUEL STATION - DRY DOCK - 150 TON TRAVELIFT - YACHT CLUB



MARINA RIVIERA NAYARIT  
AT LA CRUZ

*El sueño hecho marina...*

✦ *Come and enjoy our beautiful marina  
with first class services surrounded by spectacular views  
of the Banderas Bay.*

✦ *"one of the best experiences, no hesitation in  
letting others know what a great place you have -  
thanks to all who made our stay so enjoyable"*

*Andrew Linney, [www.nokaoui2.info](http://www.nokaoui2.info)*



**LAT 20°45'N / LON. 105°24'W**

Marina Riviera Nayarit, Marlin 39-A • La Cruz de Huanacastle, Nayarit, MX 63734 • [harbormaster@marinarivieranayarit.com](mailto:harbormaster@marinarivieranayarit.com)

Tel. (329) 295.5526 • Cel (322) 205.7467 • [www.marinarivieranayarit.com](http://www.marinarivieranayarit.com)

# Shelter from the storm...

Svendsen's Marine has savings on everything you need to keep you and your boat safe from the weather this winter!

Save 10% on Foul Weather Gear by 

when you purchase a complete outfit (jacket, trousers, boots, hat, & gloves). We have the 2010 products in stock!



All Fenders & Fender Covers  
25% Off MSRP

protect your boat with popular fenders by



Save 25% Off MSRP on



Pre-Spliced Docklines



Sale ends 1/31/10



While supplies last

**SVENDSEN'S MARINE**

1851 Clement Ave., Alameda | 510.521.8454

## LETTERS

our system back in Britain — underfunded, too many patients, not enough doctors, inadequate facilities and no preventative medicine. When our year was up, we did not renew with IMSS. A friend on that plan had a heart attack. He was taken by truck to the nearest clinic. They didn't have the necessary equipment to treat him, so he had to be taken by ambulance to Vallarta. First the ambulance had a flat tire, which had to be changed. Then they had to stop off for gas — which the patient had to pay for. But he did survive. Others have raved about the IMSS system, but based on our experience nearly a decade ago, and how much we can get for so little when paying out of our own pockets, we can't recommend it."

Gee, a woman's thorough annual check-up for \$130, and a man's for \$150. There couldn't be a much stronger argument for a medical tourism visit to Mexico, could there?

But to continue on, B.L., how would you propose that one push for "true health care reform" in the United States? All elections in California have been foregone gerrymandered conclusions for decades, courtesy of the two major parties, which are either the bitches of big business or the bitches of unions and trial lawyers. As for our ensconced Senator Boxer, she headed the spineless Senate Ethics (oxymoron!) Committee that couldn't see fit to kick Illinois Senator Roland Burris out of the club despite the fact he relentlessly misled his fellow Democratic Senators and played them like trout in order to get his seat. On the House side, we've got House Speaker Nancy Pelosi, who says a year hasn't been long enough for a House Ethics Committee to send head tax legislation honcho — and head tax evasion specialist — Congressman Charles Rangel to the prison in which he belongs. Mind you, this isn't a Democratic or Republican issue — both Oakland Mayor (and Democrat) Ron Dellums and the Republican Governor have tax issues, too — but rather is because the whole country has been sliced and diced up into special interest groups for the perpetual reelection of what walks, talks and quacks like racketeers. If you're a member of one of the special interest groups, the system works pretty well for you. But if you're like the majority of Americans, you get screwed. And as we've said before, we're not protesting on behalf of ourselves, but for the majority of people who don't have a place at the trough and, even more, for future generations who are going to get stuck with all the bills for the malfeasance.

The reason indigenous Guatemalans can't afford desirable land is because of crap government, not foreign money. You can have all the money in the world, but you can't buy real estate in



DR. GONZO

**Thank god medical care in Mexico is cheap because this BBB sailor obviously needs a lot of help.**

Australia unless you live there. You can have all the money in the world, but you can buy real estate only in one isolated section of St. Kitts. Good and honest governments can simultaneously prompt much needed foreign investment while preventing their people from having their resources plundered. As St. Bono has said, the world needs more, not less globalization, as it's precisely what has brought hundreds of millions of people out of abject poverty in the last decade. Alas, such globalization has to be administered by politicians and



# Strictly Sail® Pacific

**The West Coast's ONLY All-Sail Show!**

**April 15 – 18, 2010 • Jack London Square, Oakland, CA**

There's no better place to see and buy sailboats, sailing gear and accessories.

Over 100 seminars, parties, live music, and free sailboat rides.

For advance tickets and show details visit: [StrictlySailPacific.com](http://StrictlySailPacific.com)





**South Beach Harbor is a great way to experience San Francisco. Boats of all sizes are welcome in our protected deepwater harbor. Bring your boat to South Beach and enjoy all the attractions of the city.**



- Two guest docks for boats up to 125'**
- 20 guest berths up to 50'**
- Casual and fine dining nearby**
- Adjacent to AT&T Park**
- Easy access to transportation**
- 24 hour security**
- Free pump-out stations**



**For Reservations:**  
 415.495.4911 (x0)  
 fax: 415.512.1351  
 sb.harbor@sfgov.org  
 www.southbeachharbor.com

# LETTERS

*officials who aren't corrupt, and god knows where they're to be found.*

## ↑↓ VOYAGING BELONGS TO SEAMEN

While I agree that the apparent loss of singlehanded sailor Hubert Marcoux between Canada and Bermuda aboard the 45-ft *Mon Pays* was "preventable," I thought the 'tsk-tsk' tone of your report was unfortunate. Marcoux may well have been an experienced sailor simply living his life and sailing life the way he needed to.



COURTESY MARCOUX FAMILY

**Experienced French Canadian solo sailor Hubert Marcoux, 68, left Halifax on November 9. He never made it to Bermuda.**

Before ascending the high road, recall this popular *Latitude 38* 'Wisdom' snippet: "Voyaging belongs to seamen, and to the wanderers of the world who cannot, or will not, fit in. If you are contemplating a voyage and you have the means, abandon the venture until your fortunes change. Only then will you know what the sea is all about."

I've done several passages on well-found yachts. At age 35, for example, I was crew on a 29-footer that we doublehanded from Sri Lanka to Thailand. The only radio we had was a VHF, the diesel was dodgy, and we didn't have a liferaft. There were moments I wondered about that choice, but I have to say, my world became and remains brighter and more alive for the experience.

Now, at age 50 and being the father of a young daughter, I would voyage only with 'proper' safety gear. But alone and in my grayer years, I may just play it a bit more loose again. It's my choice. Beats fading away. As it may have been for Marcoux.

Was his a preventable loss? Likely. Regrettable or worthy of disapproval? Not necessarily ours to say.

Erik Pedersen  
*Mental Floss*, Aquarius 21  
 Santa Cruz

*Erik — If we came across with a disapproving tone in writing about Marcoux, it was unintentional and we apologize. But do we find Marcoux's loss regrettable? Absolutely. If you were to be lost at sea 'in your grayer years' because you didn't invest in a way to receive weather while offshore, we think your daughter would find it regrettable, too.*

## ↑↓ A GLIMPSE INTO THE LIFE OF A REMARKABLE MAN

We were saddened to read of the presumed loss of Canadian singlehander Hubert Marcoux and his yacht *Mon Pays*. We had only recently learned of the fascinating and adventurous life of this enterprising man, as we just finished *Around the World in 18 Years*, his autobiography.

As a novice sailor, Marcoux extensively sailed his first yacht, a 32-ft Canadian design named *Jonathan*, often by himself. While sailing alone one night, he fell asleep, and *Jonathan* — named after Jonathan Livingston Seagull — fetched up on a reef at Pohnpei, FSM. That just happens to be where we're anchored now. In any event, the uninjured Marcoux was forced to leave *Jonathan* to the mercy of the sea and reef. Nonetheless, he went on to build and sail *Mon Pays*.

Ironically, some time later, a couple managed to free *Jona-*

Happy New Year from

# SOUTH BEACH SAILING CENTER

at the  
beautifully renovated Pier 40 in San Francisco

## South Beach Riggers

**TIME TO REPLACE  
THOSE LIFELINES?**

Keep your boat and your loved ones  
safe...and on board.

**25% OFF LIFELINES  
PARTS AND LABOR**

Offer valid through January 31, 2010

### TWO LOCATIONS

399 Harbor Dr. • Clipper Marina • Sausalito • 415.331.3400  
Pier 40 • South Beach Harbor • San Francisco • 415.974.6063

## Be Clean and Green



- Mobile Service:  
*We Deliver!*
- Washing
- Waxing
- Varnishing
- Interior Cleaning



**Westwind**

Complete Yacht Care

Serving the entire Bay Area  
for more than 20 years

**(415) 661-2205**

Pier 40, South Beach on the Embarcadero • San Francisco

Call Toll Free **888-828-6789**

westwinddetailing@sonic.net  
[www.boatdetailing.com](http://www.boatdetailing.com)



**10% January Discount on:**

**Cushions + Cushions + Cushions**

**CALL NOW!**

**NORTH  
BEACH  
MARINE  
CANVAS**

**415.543.1887**

[nbmc@earthlink.net](mailto:nbmc@earthlink.net) • [www.northbeachmarinecanvas.com](http://www.northbeachmarinecanvas.com)  
Pier 40, The Embarcadero • South Beach Harbor, San Francisco

Adjacent to South Beach Harbor and AT&T Park • Close to dozens of fantastic restaurants and shops

Visit the much-expanded  
**SANTA ROSA  
 BOAT & RV CENTER**

*If it's on a trailer,  
 bring it on up –  
 sail or power!*

*Ask us about our  
 Boat Winterizing and  
 Shrink-Wrapping!*



Many of the expert technicians from Anderson's in Sausalito have now joined the team of skilled SRBRVC craftsmen that you've been trusting for more than 40 years. Call us today for all your boating & RV needs:

- Boat & RV Storage ◦ Safe, secure & affordable
- Engine ◦ Outdrive service/repair
- Winterize ◦ Shrinkwrap
- Custom fabrication & welding of all kinds
- Fuel tanks ◦ Fuel cells
- Stainless steel ◦ Aluminum ◦ Steel
- Boat & trailer service & repairs
- Electrical troubleshooting/repair
- Woodwork & custom cabinets
- Fiberglass & gelcoat repairs
- Anti-fouling bottom paint

Conveniently located: Just take the  
 Santa Rosa Ave. exit off Hwy. 101



4185 Santa Rosa Ave.  
 Santa Rosa

**(707) 586-7900**

[www.santarosaboatcenter.com](http://www.santarosaboatcenter.com)

## LETTERS

than from the reef, patch her up, and sail her 300 miles east to Kosrae, FSM. Unable to complete all of the repairs that Jonathan needed, the owners sold her to Mark Stephens in Kosrae. Mark, an American, is the co-owner and manager of the charming Pacific Treelodge Resort in Lelu, Kosrae. With his effervescent Italian wife Maria, Mark is a great resource for cruisers. Yachties are also welcome to join the variety of activities, some free, at his riverside resort.

Jonathan currently resides on jackstands on the front lawn of Pacific Treelodge while Mark works on a complete refit. It was Mark who loaned us Hubert Marcoux's book, personally inscribed to Mark by its author. We couldn't put Marcoux's book down, and highly recommend it as a great read and an entertaining glimpse into the life and adventures of a remarkable man.

Ken & Katie Stuber  
 Sand Dollar, Bristol 32  
 New Smyrna Beach, Florida

### ↑↓HOSTILE TAKEOVER OR CONDO-MANIA?

What is the straight scoop on the KKMI takeover of Anderson's Boat Yard in Sausalito? I first heard about it nine months



LATITUDE / LADONNA

**KKMI will make myriad improvements before setting up shop in Anderson's old digs.**

ago. Was it a hostile takeover or what? I later heard rumors that condos were going to be built on the site. We need some investigative reporting to clarify the situation.

Jim Cornelius  
 Belvedere

Jim — As we've reported before, the long lease Anderson's had from Clipper Yacht Harbor expired, and KKMI made the best bid for the new lease. While Ron Anderson may have preferred to stay on the site, there was no "hostile takeover." And no, condos were never going to be built on the site. These days, more than ever, you have to consider the source of your news.

The new yard will not open immediately as various improvements have to be made to get all the permits and for the KKMI folks to get things set up as they like them. But rest assured, you'll know when they start hauling.

### ↑↓SEARCHING FOR HA-HA ALUMNI

Sorry to bother you about such a mundane issue, but could you direct me to a list of all the boats that participated in the '08 Ha-Ha? The other day I met a couple who mentioned they'd been on the rally with us, but now I can't recall the name of their boat. But if I saw it, I'm sure I would recognize it. Thanks for your help — and congrats on yet another great rally. Our only regret is that we've been in Sausalito this season!

Scott Brear  
 San Francisco

Scott — Your question is no bother at all. In fact, we think a number of people might be interested in knowing that everyone who has ever signed up for a Ha-Ha can be found by going to [www.baja-haha.com](http://www.baja-haha.com), clicking on 'Alumni Lists', and choosing the year they're looking for. If, on the other hand, you know only



# Why settle?



## **Ballena Isle Marina**

Alameda 510.523.5528

## **Jack London Marina**

Oakland 510.834.4591

## **Treasure Island Marina**

San Francisco 415.981.2416

## **Martinez Marina**

Martinez 925.313.0942

You don't settle for less, why do it with your marina? Join one Almar marina and gain access to seven Bay Area marinas. Almar's reciprocal program takes the hassle out of your boating weekend. A simple call to the marina office and you can spend the weekend at Jack London Square or Treasure Island. Maybe a trip to a few of Almar's seven Southern California marinas. We make it so easy you may find yourself using your boat.

Almar boaters receive a 10% discount on any fuel purchase at Jack London Square and Ballena Isle Marina. Jack London Square Marina has just upgraded it's fuel dock with high speed fuel dispensers and now has the fastest pumps in the Bay Area. You don't have to settle anymore.

Almar is the largest operator of saltwater marinas in the country. Almar Marinas provide a wide range of services and programs that few marinas or yacht clubs offer. Some of these programs include: monthly boating seminars, boat handling classes, navigation courses and organized outings to local anchorages. Each marina offers wireless high speed internet access, which can be used with your reciprocal privileges at any Almar Marina. To see the difference, visit one of our marinas this weekend.



# almar.com

# SHAFT SHARK

**The best rope,  
line and debris  
cutter there is!**

Two piece unit

For both power and sail

Now available for  
sail drive systems.



747 Aquidneck Ave.  
Middletown, RI 02842

401-847-7960

Fax: 401-849-0631

sales@ab-marine.com

www.ab-marine.com

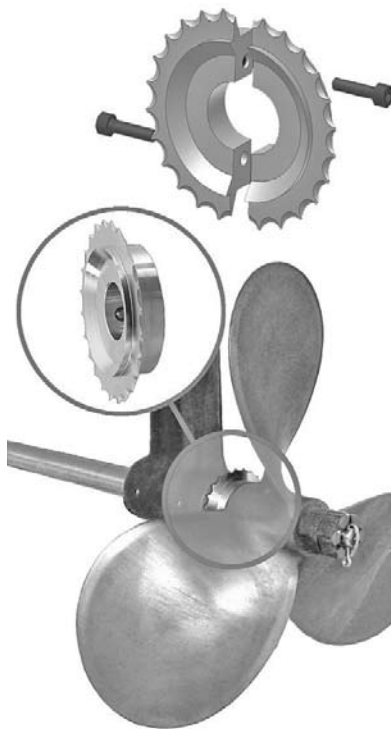

## Gori propeller

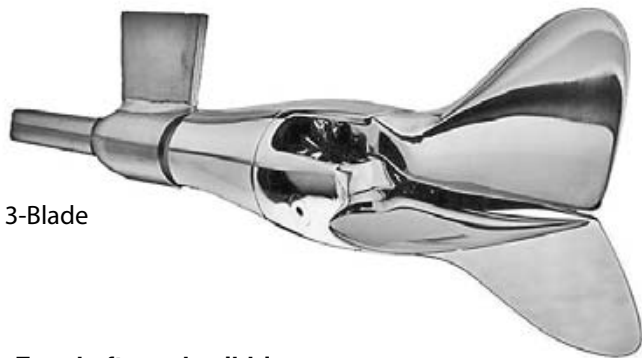

3-Blade

- For shafts and saildrives
- Both 2 & 3 blade available
- Lowest drag when sailing
- The champions choice



747 Aquidneck Ave.  
Middletown, RI 02842

401-847-7960

Fax: 401-849-0631

sales@ab-marine.com

www.ab-marine.com

**CALL US TODAY!**

**800-801-8922**

## LETTERS

the boat or person's name, enter it in the Google search box at the bottom of the home page. In a fraction of a second, you'll get the answer you're looking for. It's how we reminded ourselves that you did the '08 Ha-Ha aboard your San Francisco-based Nauticat 38 Samantha.

### ↑↓"I THINK LEE HELM GOOFED"

I think an error was made in the computation of fuel consumption in last month's *Max Ebb* article.

If the fuel consumption is .05 gallons per horsepower hour — something that I'm not sure of — it is per horsepower hour actually used, not per rated maximum horsepower. For instance, my Cal 39 has a 48-horsepower diesel. Forty-eight horsepower times .05 gallons per horsepower hour equals 2.4 gallons per hour. Maybe that is my fuel consumption rate when using full throttle to make an emergency stop or to quickly start — and before the prop starts cavitating. But even then I doubt that my engine really consumes 2.4 gallons per hour. My actual measured fuel consumption at cruising speed is between .6 and .7 gallons per hour. So the calculation run in the article should be made with the actual developed horsepower during the steady run, not the rated horsepower. As a naval architect student Lee Helm should understand that.

Sam Crabtree  
*Catch The Wind*, Cal 39  
Richmond

Sam — Since we're writers, not naval architects, we asked Lee for her response:

"For sure, your boat needs only, like, a small fraction of the installed hp for motoring in good weather. That's how sailboat auxiliaries are sized — the reserve power is there to move you into strong headwinds and waves, which have a severe effect on small sailboats. Engines on ferries and ships are sized to run much closer to rated continuous power.

"Also, that 48 hp is probably a 'recreational' rating. A similar engine would have a considerably lower power rating for commercial service.

"All that aside, we now have some actual measured fuel consumption data for the new 149-passenger boats, presented at a recent meeting of our local Society of Naval Architects and Marine Engineers. Running at a slightly reduced speed, they are consuming 3.7 gallons per mile. At an average passenger load of 30%, that's, like, 12.08 seat-miles per gallon of diesel.

"And, to be really rigorous, if we're comparing seat-miles per gallon to automotive mpg, we also have to take into account the energy content of diesel fuel vs gasoline (130,500 btu/lb for diesel vs 115,000 btu/lb for gasoline). The passenger-miles per gallon of gasoline having equivalent energy works out to 10.64.

"This is, like, a little better than the 9.1 mpg estimate based on installed power and engine data, but they are also running the ferries a little slower than design speed.

"You still have a lower carbon footprint if you drive your own SUV across the bridge. It's a no-brainer. You can easily do five times better with a mid-sized car in the HOV lane."

### ↑↓PROVEN DINGHY LIFTING SYSTEM

A reader asked for suggestions on launching a dinghy from a small boat. I have a Catalina 30 and I carry a 10-ft Zodiac 'Zoom' model that just fits on the foredeck. The wooden transom is all the way back against the mast and the bow is just inside the lifelines.

If I'm going to be sailing a long distance before using the

Northern California

# Boat Fest

Marina Village Yacht Harbor  
Alameda, California

**Feb 18-21** 2010

**Thu & Fri: 12-5 • Sat & Sun: 11-5**

**Winter Sales Event &  
Boating Celebration  
for the Whole Family!**  
Free Admission & lots of Free Parking

- Power & Sail
- New & Used
- 100+ Yachts For Sale
- Seminars
- Marine Exhibits
- Music & Food

For complete information

[www.BoatFestival.BlogSpot.com](http://www.BoatFestival.BlogSpot.com)



# HOGIN SAILS

Winter sale now in effect!  
Through February 28.

**10% OFF**  
all new sails!

Call or visit us today.

At Hogin Sails, we are dedicated to work with our customers to give them the custom designed sail they have always wanted. Call our sail designer for a free Consultation on how a new sail will improve the performance of your boat and ease of your sailing experience.

**510.523.4388**  
1801-D Clement Avenue  
Alameda, CA 94501  
www.hoginsails.com  
Happy Holidays

## LETTERS

dinghy, I keep it rolled up and in a bag belowdecks until I want to use it. Then I unroll it on the foredeck and insert the folding plywood bottom. Yeah, it's old and low-tech. I use a foot pump to inflate it, and then I attach a bridle to it. The bridle consists of three lines attached to a stainless steel ring at one end. The other ends of these lines are attached with spring-loaded snaps to the two rings on the bow that are normally used to attach a painter, and to an eye on the wooden transom. The lengths of these three lines are adjusted to keep the dinghy horizontal when it's lifted by a line attached to the stainless ring. I lift the dinghy using a block & tackle that is normally used in the Lifesling MOB system. This tackle provides enough purchase to lift my dinghy without the use of any winches. I'm 70 years old and of relatively small build, so if I can lift it by hand with the block & tackle, almost anybody can.

I then attach one end of the Lifesling tackle to my spinnaker halyard, and the other end to the stainless ring on the bridle. I pull the spinnaker halyard up far enough that the dinghy will clear the lifelines when the tackle is pulled to its maximum extent. I lift the dinghy over the lifelines using the tackle, then push it over the side, then slide it down the side of the boat and into the water.

It's amazingly easy to reverse this process to recover the dinghy. This will give you practice hauling an MOB aboard — although you'll need a winch to get enough lifting force for a human body,

I have occasionally attached the outboard motor before lowering the dinghy into the water, but I prefer to put the outboard on at the stern after the dinghy is in the water. That way I don't have to carry the outboard forward to attach it.

I've been able to get the dinghy in and out of the water in less than 15 minutes by this method. Try it, you'll like it!

Lloyd Chase  
La Chasse, Catalina 30  
Berkeley Marina

### ↑↓ "AM I PAYING FOR THIS PISSING MATCH?"

For what seems like forever, I've been disgusted by what seem to have been the never-ending legal battles between



GILLES MARTIN-RAGET

'BMW Oracle 90' lifting her leg on 'Alinghi'.

Alinghi and BMW Oracle over the America's Cup. But it raised a question in my mind, and when I get the answer I'm afraid I'm going to be even more disgusted. I can only assume that we, the American taxpayers, are having to pay for

the courts, the judges and the staffs in this pissing match. Please tell me I'm wrong.

Jeff Grathe  
San Jose

Jeff — If we're not mistaken, each side has to pay certain 'court fees', but we suspect they don't cover all the associated costs. Perhaps someone in the legal field can give us a better answer.

### ↑↓ GETTING FIRED UP OVER NEAR-COLLISIONS

We're sitting in the Knight & Carver Yard in San Diego, not 30 feet from the railroad tracks. We're trying to get some

# Yacht owners can trust **PACIFIC CREST CANVAS\*** for the best in design, service and quality.

## • **Offshore Dodger™**

Welded aft handrail  
Bolt-on side handrails  
Lexan windshields

## • **Baja Awning™**

Lightweight and waterproof  
Durable and easy to launch  
Multiple side screen configurations

## **15% Winter Discount: Still the Highest Quality Products at the Best Prices**



Pete Fuller, a professional Bay Pilot with good taste in both fine sailing yachts and offshore dodgers!

## • **Coastal Dodger™**

Affordable designs  
Same high quality materials  
Same superior workmanship

## • **Cruiser's Awning™**

Easy setup off your dodger  
Flies with no bulky frame  
Comes with shade screens

Open Monday-Friday 8:00-4:00  
Saturday by appointment

**(510) 521-1938**



2021 Alaska Packer Place  
Alameda, CA 94501  
Grand Marina

\*Former owner at Pacific Coast Canvas

## **RICHARDSON BAY MARINA** formerly Kappas Marina

### MODERN FACILITIES IN A WELL-PROTECTED HARBOR

**Concrete Dock System**

**Well Maintained Facilities**

**Beautiful Surroundings**

- DEEP WATER BERTHS: BASIN AND CHANNEL DREDGED
- CARD KEY SECURITY SYSTEM
- DOCK CARTS
- PUMP OUT STATION
- AMPLE PARKING
- CLEAN SHOWER AND TOILET FACILITIES
- WITHIN WALKING DISTANCE: MARKET/DELI, LAUNDROMAT, RESTAURANT
- AT EACH BERTH: LARGE STORAGE BOX, METERED ELECTRICITY, PHONE HOOKUPS, WATER

### BERTH YOUR BOAT IN SAUSALITO

415 332-5510 [www.richardsonbaymarina.com](http://www.richardsonbaymarina.com)  
100 Gate Six Road, Sausalito • Fax 415 332-5812



Port Townsend, WA  
since 1975

### **Featuring:**

**Port Lights in 316 Stainless Steel, Bronze and Copolymers starting at \$109.95**

**New full line of inflatables starting at \$596 + free shipping**

### **See us at:**

Seattle Boat Show  
Jan 29-Feb 6, 2010  
Strictly Sail Chicago  
Jan 28-31, 2010  
Strictly Sail Miami  
Feb 11-15, 2010



Deck Wash  
Cleats • Handrails  
and Other  
Marine Hardware

See catalog on the website:

**[www.newfoundmetals.com](http://www.newfoundmetals.com)**

**Toll free: 888.437.5512**

**[nfm@newfoundmetals.com](mailto:nfm@newfoundmetals.com) • 360.385.3315**

# WHALE POINT MARINE & HARDWARE CO.

**A FAMILY OWNED & OPERATED BUSINESS FOR THREE GENERATIONS**  
**MARINE PARTS & ACCESSORIES, PLUS A COMPLETE HARDWARE STORE**

Go to **WhalePointMarine.com** for additional discounts!

## FORCE 10

3 Burner Propane Stove



**FORCE 10**

Model 63351

3-burner

**Whale Pt \$1199<sup>00</sup>**

Model 63251: 2-burners

**Whale Pt \$1099<sup>00</sup>**

## GILL Deckhand Gloves



**FREE**  
with purchase of Gill Foulweather Gear Suite

Gill - present quality in sailing gear. Sizes: S, L & X.  
List \$21.99 • **Whale Pt. \$19<sup>99</sup>**

## PORTABLE HEATER

Indoor safe propane heater.



Mr Heater

4,000-9,000 BTU: **NOW \$99<sup>99</sup>**

## HORSESHOE BUOY & M.O.B. POLE

USCG Approved

M.O.B. Pole  
**Now \$149<sup>99</sup>**

Horseshoe or Pony Buoy  
**Now \$89<sup>99</sup>**



## 2010 CALENDARS



Many styles available: Woodenboat, Sail, Art, Mariners Book of Days, Light-houses, 7 Seas calendar, Cruising, World of Boating, Bay Area Tide Calendar...  
**20% OFF** \*Qty. Ltd.

## DOCK-RITE Boat Fenders



6.5" x 21" • **NOW \$18<sup>99</sup>**  
8.5" x 27" • **NOW \$34<sup>99</sup>**

## FILTER 500 FGSS by Racor



Filter Element

**Whale Pt \$8<sup>99</sup>**

Filter Unit: List \$246.99

**Whale Pt \$179<sup>99</sup>**

## PORTA POTTI Portable Toilet

Model 135. Two piece fresh water toilet. 2.6 gal holding tank detaches for easy emptying.  
List 89.95

**NOW \$79.95**



## LETTERS

last-minute work done before we maybe/hopefully/finally get to sail south. While enjoying a glass of wine, I read the December issue letter about the near collision between the Marquesas 56 *Dolce Vita* and another unnamed boat in the Ha-Ha. We had a similar experience in '01. Dave's description of the incident really got us fired up.

For us, it occurred on windy Leg Two. We were on a port gybe, not starboard, and were gradually sliding eastward toward a vessel under power. Our radar tracks indicated a collision course. We hailed the other boat on VHF and it turned out to be one of the few powerboats in the Ha-Ha that year. One of the ones that was doing incredibly well fishing while we were catching nothing but kelp. In any event, they said they would watch out for us. We continued on our course, and became more and more nervous as we kept getting closer and closer. As we drew within about 100 yards, we got back on the VHF in near panic, and asked that they *please* do something to help us avoid a collision. By this time we were so close that our options were very limited.

We got as close as one boat-length of each other, at which point the powerboat finally gunned their engines. They zipped just in front of us, and we luffed up a bit to get behind them. It was way too close a call for two boats doing about 10 knots on a dark ocean.

We got a chance to chat with the folks on the powerboat down the road. They were apologetic and very reasonable about the whole episode. They explained that they had made some miscalculations:

1) They had a hard time visualizing precisely where we were, given that we had a tri-color rather than boat-level running lights.

2) They had seriously underestimated how fast we were going because we were "just sailing." They expected to pull in front of us without incident.

3) They didn't fully understand the limitations we had in our course with respect to the wind angle — especially since we were sailing shorthanded.

What got me really fired up about Dave's letter was the bit where he and the rest of his crew suggested that if the other boat "had just fallen off a bit, he would have had plenty of time



**Pete at the helm of the new 'Kiapa', a Schooner Creek-built M&M 52.**

to cross our stern." It reminds me vividly of the predicament we were in with the powerboat. It was windy! We were sailing as deep as we safely could! We were doublehanded, so gybing would have been a bit of a project, one we probably didn't have time to pull off safely once we'd gotten to within a few hundred yards. While we couldn't fall off any deeper, we couldn't head up either to get behind the power vessel, because heading it up in such conditions would have increased our speed so drastically that we wouldn't be able to get behind the boat without a big broach or round up.

Unless I have the facts wrong, the crew of *Dolce Vita* made a serious miscalculation. The other vessel would have had to head up rather than fall off to pass behind them. Often times, such as when it's breezy, it's tough to do on a boat

LATITUDE / RICHARD

205 Cutting Blvd, Corner of 2nd, Richmond  
510-233-1988 • FAX 233-1989

Mon-Sat: 8:30am - 5pm • Sun: 10am - 4pm • whalepoint@acehardware.com

Go to **WhalePointMarine.com** for additional discounts!

# Own a dock on San Francisco Bay! Perfect Location - Great Investment

Just dredged  
40' monthly rent \$342

EMERY COVE  
YACHT HARBOR

**BUY A SLIP** – Save money & earn equity! Save 1/3 of your rental cost. Enjoy big tax savings as a slip owner. Emery Cove Yacht Harbor is the only marina on the Bay with FEE SIMPLE (not a grounds lease) dockminium ownership.  
**OR RENT A SLIP** – 35-60' slips, rates from \$8.55 to \$9.55.  
**MARINA GUARD®** – cutting edge electrical ground fault monitoring system.  
**FREE** – Wireless Internet

Mathiesen Marine  
Michael Wiest Yacht Sales  
Emeryville Yacht Club  
on premises



**CALL FOR A MARKETING PACKAGE • 510-428-0505**  
3300 Powell Street, Emeryville, CA 94608 • [www.emerycove.com](http://www.emerycove.com) • Email: [info@emerycove.com](mailto:info@emerycove.com)

## SWISS TECH SPECIALTY SAILING GEAR

Designed and tested for world-wide cruising and rigorous seamanship challenges.

### MAST LIFT

*Our Signature Product!*



- 10-to-1 winch hoist for safe and easy mast climbing, easy MOB maneuvers, and other hoist tasks
- Top-of-the-mast safety harness & bosun's chair

### The Authentic Self-Retracting Anchor Buoy

### Mooring Gear

A variety of seamanship products for catching mooring buoys, bullards and mooring posts, all with self-releasing mechanisms.



Mooring Safety Lock



Your purchases will trigger a 10% increase to Swiss Tech America's regular sale-to-sale contribution to Make-a-Wish Foundation.

Check out Ms. Mermaid for product animations at:

[www.swisstech-america.com](http://www.swisstech-america.com)  
(408) 505-SAIL (7245)

## HANSEN RIGGING



### BUILDING SPEED for over 20 years

- Ultra lightweight rigging
- Latest innovations
- Rod rigging
- Rotary swaging
- Masts
- Booms
- Deck layouts
- Deck hardware

[www.hansenrigging.com](http://www.hansenrigging.com)  
(510) 521-7027



# VALLEJO MARINA

## Gateway to the Bay & Delta

**48-ft. BERTHS NOW AVAILABLE**



### Shorter Days Are Here

Use your boat more by keeping it closer to home!

- Competitive Rates!
- Covered and Open Berths
- Free Pumpout Stations
- Ferry Service to San Francisco
- Full Service Boat Yard and Chandlery
- Two Restaurants for Breakfast, Lunch, Cocktails and Dinner
- Great Restrooms and Showers
- Easy access to San Francisco Bay and the Delta



## (707) 648-4370

Fax 707-648-4660

42 Harbor Way, Vallejo, CA 94590

[www.ci.vallejo.ca.us](http://www.ci.vallejo.ca.us)

## LETTERS

sailing downwind without risking a big mess. It's one of the reasons that it's important to figure out right-of-way early, monitor closing boats like crazy, and work on your bail-out plans should things not go as expected.

Pete and Sue Wolcott  
Kiapa, M&M 52 cat  
Kapaa, HI

*Pete & Sue — Because most of us normally drive cars, which are much more maneuverable than sailboats, we suspect that many of us don't adhere to Rule 16 — regarding Stand-On Vessels — as closely as we should. It reads, "Every vessel which is directed to keep out of the way of another vessel shall, so far as possible, take early and substantial action to keep well clear."*

*Of course, if changes are made early enough — say from a half-mile to a mile away, depending on the wind strength and boat speeds — they don't even have to be substantial to be adequate. But what the skippers of all give-way vessels must understand — and what may not be so obvious to powerboaters — is that sailboat speeds often vary dramatically in just a few seconds. It can be hard to gauge if they are on a collision course with you or not.*

*We hope everyone is also up on Rule 17a*

*"1) Where one of two vessels is to keep out of the way, the other shall keep her course and speed."*

*In other words, it's not a 'let's-both-change-course-and-speed-a-little-bit' situation, because that could lead to confusion and collisions. The stand-on vessel needs to be as constant as she can be in order to help the stand-off vessel keep clear of her.*

*"2) The latter vessel may, however, take action to avoid collision by her maneuver alone, as soon as it becomes apparent to her that the vessel required to keep out of the way is not taking appropriate action in compliance with these Rules."*

*So even if you're the stand-on vessel, if the situation gets serious enough, you have to try to avoid the collision. Even if you have no choice but to crash jibe or round up.*

*Then there's Rule 17b*

*"When, from any cause, the vessel required to keep her course and speed finds herself so close that collision cannot be avoided by the action of the give-way vessel alone, she shall take such action as will best aid to avoid collision."*

### ↑↓THEY'RE TOO BUSY WITH DRUG INTERDICTION

In regard to the loss of JoJo, and the Coast Guard's apparent inaction, I no longer depend on the Coasties. They seem overwhelmed by their drug interdiction work. I have friends whose boats have been boarded rather roughly at night between Catalina and the other Channel Islands. I'll bet they would have had a hard time finding the Coast Guard if they got in trouble.

Mike Kennedy  
Conquest, Cal 40  
Southern California

*Mike — If a boat got into so much trouble that there was a risk of life at the Channel Islands, there is no question that the Coast Guard would be there as fast as they could. That's what they do best. One thing we learned from investigating the JoJo incident is that the Coast Guard doesn't do 'beach rescues' or 'sand rescues'. Those are left to local 'coastal incident' squads. Where were the ones that should have showed up at Stillwater Cove? That's a good question.*

*See page 108 for in depth coverage on that incident.*



# NORSTAR 40

BUILDERS: GARY AND STEVE NORDTVEDT  
DESIGN BY ROBERT H. PERRY

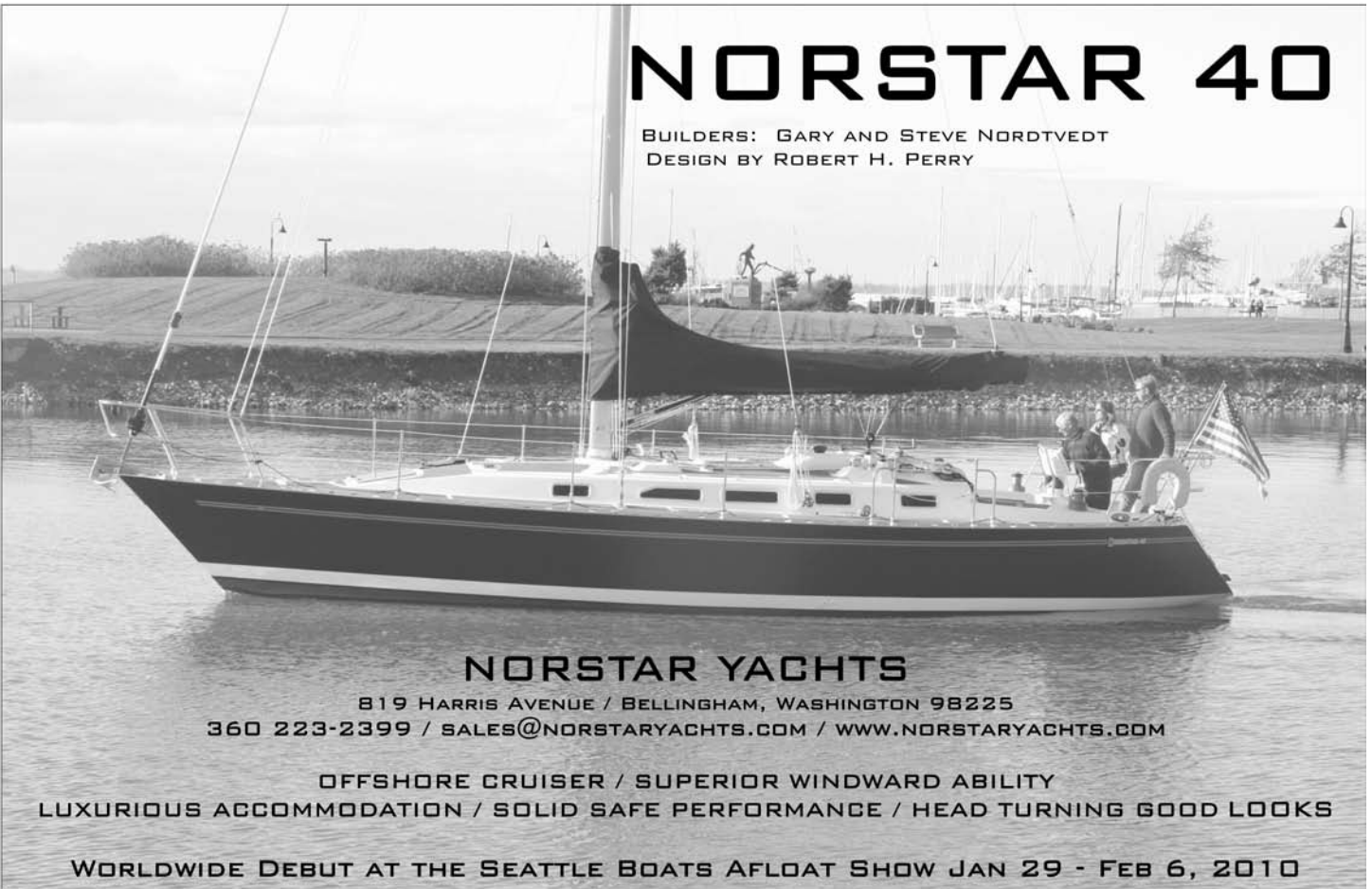

## NORSTAR YACHTS

819 HARRIS AVENUE / BELLINGHAM, WASHINGTON 98225  
360 223-2399 / SALES@NORSTARYACHTS.COM / WWW.NORSTARYACHTS.COM

OFFSHORE CRUISER / SUPERIOR WINDWARD ABILITY  
LUXURIOUS ACCOMMODATION / SOLID SAFE PERFORMANCE / HEAD TURNING GOOD LOOKS

WORLDWIDE DEBUT AT THE SEATTLE BOATS AFLOAT SHOW JAN 29 - FEB 6, 2010

## ULTRA SMALL CABIN AND WATER HEATER

### NEW HEATER BREAKTHROUGH

Be comfortable all year round with a quiet, reliable Webasto hot water heating system. Can be linked to pre-heat an engine and provide all the hot water you'll need in the galley or for showers.

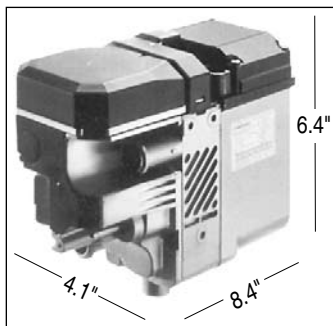

## Webasto

### CERAMIC IGNITION SYSTEM

- Heat output 17,200 btu/hr (5kw)
- Fuel Consumption .18 gal/hr
- Power Consumption 32 w
- Weight 6.4 lbs

CALL FOR  
MORE  
INFORMATION



## SWEDISH MARINE

1150 BRICKYARD COVE RD., SUITE B6  
PT. RICHMOND, CA 94801 (510) 234-9566

## OFFICIAL SPONSOR AND MARINE ELECTRICIANS FOR 2010 PACIFIC CUP

30+ years of one-design, PHRF and offshore racing experience at your service.



Ask us about our trade-in credit for upgrading your system:

Up to \$250

Performance Electronics Need Not Be Expensive

UPGRADE • REPAIR • REPLACEMENT



## Sausalito Marine Electrical Shop "The Project Place"

300 Harbor Drive,  
Sausalito, CA 94965  
(415) 332-9030

CERTIFIED:  
**ABYC**  
Boat Electrical Association

CERTIFIED:  
**NMEA**  
National Marine Electronics Association

www.sausalitmarine.com • info@sausalitmarine.com

# LOOKING FOR THE PERFECT CRUISING BOAT IN MEXICO?

**Your First Stop:**

**[www.vallartayachts.net](http://www.vallartayachts.net)**

**Second Stop:**

**Our two offices now in  
Mazatlan and Puerto Vallarta**

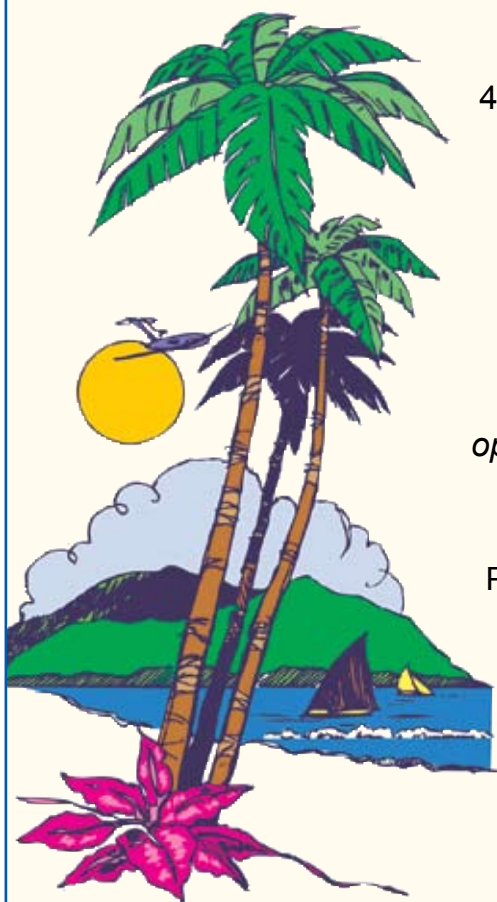

40 Sailboats  
26' to 67'

\$9,900 to  
\$350,000

And great  
buying  
opportunities.

Example:

Pristine 2005  
Catalina 42  
MkII

Just...  
**\$199k!**

Or call...

**866-578-2636**

VALLARTA  
*Yachts*  
YACHT SALES & SERVICE

## LETTERS

### ↑↓ LIVES SHOULDN'T BE RISKED FOR A POSSESSION

Once a mariner puts out a *mayday*, he/she has decided that help is needed to save life and limb. But I don't think anyone should have to risk his life for a possession. However, human nature being what it is, if I'd been in the same situation as the Livengoods, I'd probably have called the Coast Guard for help, too.

Jim Revard  
Planet Earth

### ↑↓ WE ARE OUR OWN FIRST LINE OF DEFENSE

Our hearts go out to the Livengoods. Having heard only their side of the story, we feel that the Coast Guard could have done more. But we can't help wondering if the Livengoods didn't have a secondary anchor they could have deployed to stabilize things. And if they didn't, why not?

The other side of this — and we've seen it all too often — is that many Americans seem to think that their life comes with a guarantee, and that everyone else is responsible for bailing them out when they get in a sticky situation. Sailors, mountain climbers, trekkers, back country skiers, backpackers and so forth need to understand that these sports can be extreme, and many times there is nobody to rely on but oneself. Everyone must be responsible for saving their own ass. If someone happens to come along and save you, that's nice, but you can't expect it. In addition, if you put yourself in a bad situation, you can't blame others.

Our point of view is perhaps colored by the fact that we did a circumnavigation. When you do that, you quickly learn that you make your own breaks and have to count on yourself to get out of situations. It's not like sitting on a couch at home, where you can just grab a phone and call for any kind of help you might need. Each one of us is our own first line of defense — not the Coasties or anyone else.

Name Withheld By Request  
Sausalito

### ↑↓ THEIR MISSION IS TO SAVE LIVES, NOT BOATS

It's important that mariners get the message that the Coast Guard is sending, which is that they save people, not boats. Karl Livengood's ultimate conclusion — that he would have been better off calling a commercial salvage company — seems to reflect the new reality. Before, I'd have probably issued a *mayday*, too, but after reading the Livengoods' account, I'd call BoatUS for a tow.

Richard Deep  
Discovery, Hunter 31  
South Beach

Richard — The only tow and salvage boat service between Pillar Point and Morro Bay — a distance of about 150 miles — is Vessel Assist in Santa Cruz. According to the Coast Guard, the Livengoods called them, but the Vessel Assist boat didn't arrive in time to save JoJo.

### ↑↓ WHY DIDN'T THEY HAVE A SECOND ANCHOR?

The Coast Guard's mandate is to save lives, period. I wasn't at Stillwater Cove when the incident happened, but if the Livengoods were setting the anchor when their windlass jammed, why didn't they motor back to where they came from? And didn't they have a second anchor they could have set after they ran aground?

Bill Sherman  
Cyclone, Catalina 30  
Blaine, WA

## 40 Years of Exquisite Trimarans



**Just  
Introduced...  
DRAGONFLY  
28!**



**2 more  
recent  
West Coast  
deliveries!**

**28 • 35 • 40**

**See what all the excitement's about:**

**[www.trimarans.com](http://www.trimarans.com)**

**908•656•4342**

**ESSEX  
CREDIT**

- NEW
- USED
- REFINANCE



## Boat Loans Made Easy®



Let our 29 years of experience go to work for you!

Richard Tressler  
866-377-3948 ext. 47008

[www.essexcredit.com](http://www.essexcredit.com)

EQUAL CREDIT OPPORTUNITY LENDER

Loan Amounts from \$25,000  
Instant Loan Approvals\* • 90 Days to First Payment\*

\*Subject to Loan Program Guidelines and Credit Approval  
Reference Code = MAR931



**5<sup>open</sup>  
.70**

Contact our  
new NorCal Rep –  
**Barry Demak**  
(408) 905-7245  
[norcal@opensailingusa.com](mailto:norcal@opensailingusa.com)  
to schedule your  
demo today!

**Pure One Design!**

One Design Starts  
Now Available on  
San Francisco Bay



310-928-6570

[www.OPENSAILINGUSA.com](http://www.OPENSAILINGUSA.com)

# We Still Offer More!



## Making boating easier – and more fun! is what a marina should be all about.

That's why Oyster Cove Marina rates number one with many Bay Area boaters. It's an exclusive yet reasonable facility of 219 berths, accommodating pleasurecraft in slips up to 60-ft long.

## Oyster Cove is the private Peninsula marina closest to Blue Water boating.

Want to cruise to Sausalito, lunch at Tiburon, or sail to Angel Island? How about a day's fishing outside the Gate, or a weekend at the Delta? No other private Peninsula marina is better situated or offers nicer, fresher surroundings.

- Berths 30 feet to 60 feet
- Double Finger Concrete Slips
- Telephone Available
- Five Minutes from SFO
- Heated Dressing Rooms & Showers
- Laundry Room
- Nightly Security Patrol
- Complimentary Ice
- Cable TV/High Speed Internet
- End Ties Available at \$5.95/Ft!



## OYSTER COVE MARINA

385 OYSTER POINT BOULEVARD #8A  
SOUTH SAN FRANCISCO

(650) 952-5540

## LETTERS

Bill — *Hindsight is 20/20, of course, but in retrospect it seems there were a number of operator errors that contributed to the loss of JoJo.*

### ↑↓ MOTOR LIFE BOATS DON'T CARRY LAUNCHES

The Coast Guard crew on the 47-footer was probably of the generation trained to interdict drugs and stop terrorists, not to help mariners in the old way of saving lives first and



COURTESY USCG

**The Coast Guard's 47-ft MLBs cost about \$1.2 million each — and they don't carry launches.**

then, if possible, the boat. Oh yeah, and to make sure those on-the-water safety inspections get done. I'm glad to hear that no one was seriously injured, as this could have been much worse. But it still sucks to lose your boat, particularly after what began with

such a minor problem. The bottom line for me is that you don't depend on the government — your own tax dollars — to save your ass.

I'd be shocked if it's true that the Coast Guard didn't have a launch on the 47-footer that they could have deployed. In fact, I'd like *Latitude* to get an explanation — not a canned press release — to explain why they didn't launch an inflatable.

Lani Schroeder  
Balance, Endeavour 43  
Seattle

Lani — *The 47-ft motor lifeboat didn't launch an inflatable because they don't carry them. In fact, Station Monterey Commanding Officer Lt. Michael Kahle told us that "small inflatable rafts are not a standard Coast Guard platform." We were surprised at the answer, but he insists that it's true.*

### ↑↓ DISAPPOINTED THAT THEY JUST WATCHED

My expectation is that any person — Coast Guard, sailor, paddler, bystander — would do everything he could to help secure a boat in *JoJo's* situation. It's very disappointing to me that anyone would simply stand by and watch the boat be destroyed on the beach.

Chip Prather  
California

Chip — *Careful. If you start expecting bystanders "to do everything they could" to secure boats in situations such as JoJo's, we don't think it would be long before somebody got seriously hurt or killed. Well-intended folks who aren't familiar with grounded boats, the ocean and waves can be a big danger to themselves and others. A couple of years ago a cruiser in Mexico was killed when he was hit in the head by a grounded vessel rolling from side to side.*

### ↑↓ THEY SHOULD HAVE DONE MORE

The Coast Guard should have done more. Why not help save the boat? They were on site with no other distress calls to handle. It would have been as good as simulated training, and would not have cost them any more than standing by.

We, along with lots of other cruisers, watched and helped the Mexican Navy rescue of the 55-ft trawler *Cat's Meow* after

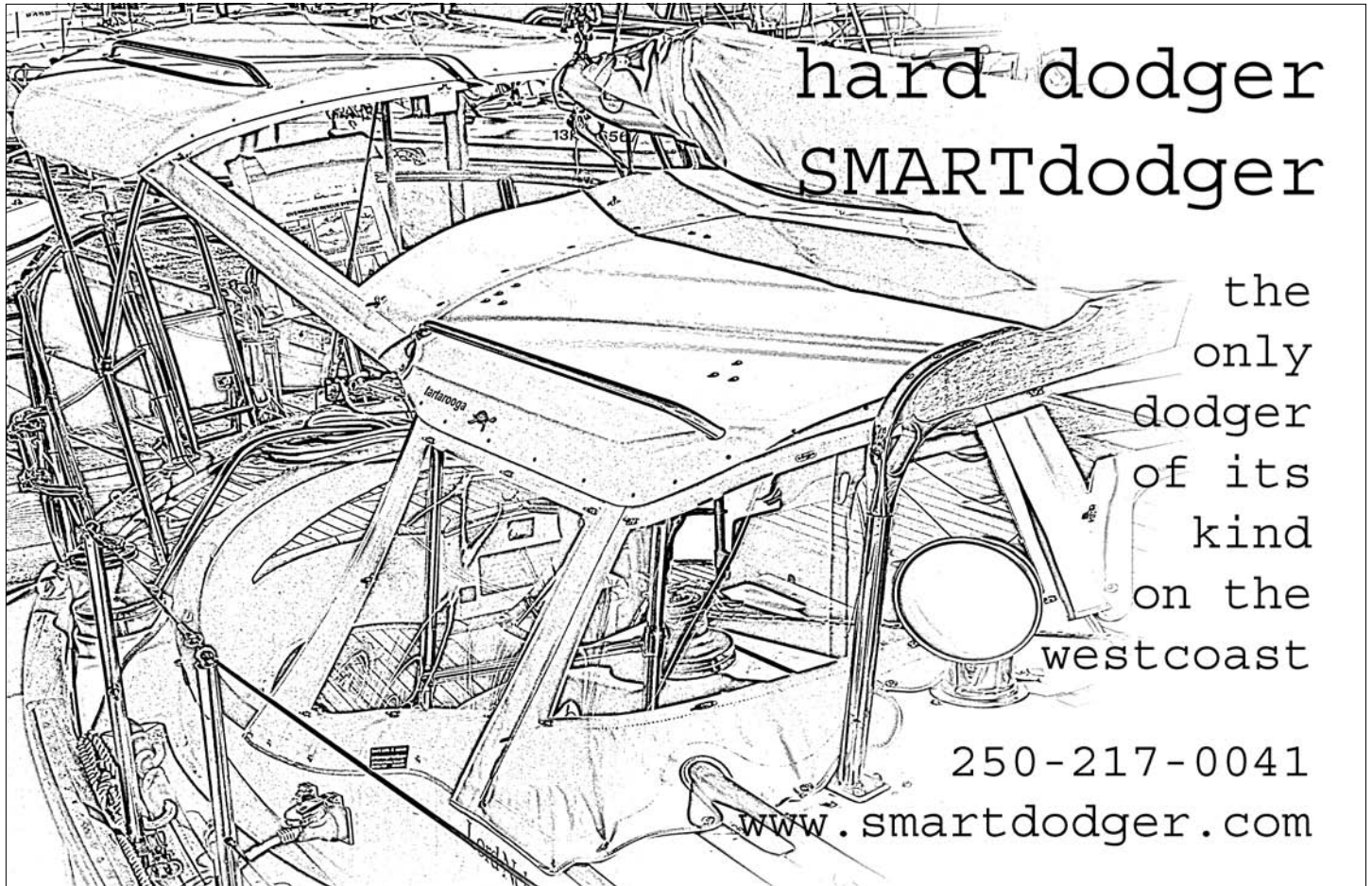

hard dodger  
SMARTdodger

the  
only  
dodger  
of its  
kind  
on the  
west coast

250-217-0041

[www.smartdodger.com](http://www.smartdodger.com)

**MATTHEW GARDNER YACHT PORTRAITS**  
[WWW.GARDNERPORTRAITS.COM](http://WWW.GARDNERPORTRAITS.COM)  
 SEE WEB SITE FOR SPECIAL OFFERS AND DISCOUNTS  
 707 567 6892

**COVER CRAFT**

**DURABLE GOODS**

Better Materials  
 Thoughtful, Innovative Designs  
 Top Quality Workmanship

All sewing in Tenara thread

- Classic dodgers and biminis
- Wavestopper hardtop dodgers
- Drop-top folding dodgers
- Enclosures • Custom canvas

1230 Brickyard Cove Road, #106  
 Pt. Richmond, CA 94801  
 In Brickyard Cove Marina

**(510) 234-4400**

Quality  
Yacht  
Canvas

License #0E32738

# TWIN RIVERS MARINE INSURANCE

AGENCY, INC.

*"Your Boat Insurance Specialists"*

7 Marina Plaza • Antioch, CA 94509

At The Antioch Marina

**Insurance made simple, affordable and effective.**

- Mexican Liability • Broad Navigational Areas
- Shop Your Renewal & \$ave ~ Flexible Survey Requirements
- Liveboards • Agreed Value Policies



**Get a quick quote today at:**

**[www.BoatInsuranceOnly.com](http://www.BoatInsuranceOnly.com)**

**(800) 259-5701**

**Years of unbeatable experience to match your needs to the right product.**

**Representing...**

**AIG** Global Marine

**CHUBB PERSONAL INSURANCE**

**INTERNATIONAL MARINE UNDERWRITERS**

**TRAVELERS**  
Insurance Group  
**ace seguros**

**MARKEL INSURANCE COMPANY**

**ace recreational marine insurance**

**FOREMOST INSURANCE GROUP**

**LLOYD'S**

**AMERICAN MODERN INSURANCE GROUP**

**Worldwide Coverage**

**West Coast □ Mexico □ East Coast**

**Caribbean □ Pacific □ Atlantic**

## LETTERS

it went on the rocks in the Sea of Cortez. I think the Mexican Navy was there for two or three days. They worked their butts off. Why couldn't the Coast Guard do the same?

Greg Rodgers  
*Me Gusta*

Formerly of MV *Mikelali*

*Greg — The reason they couldn't do the same is because — and you're not going to like this — it would have been illegal. Don't yell at the Coast Guard, yell at Congress and Homeland Security, who give the Coasties their marching orders.*

*The operating policies of the Mexican Navy and the U.S. Coast Guard are as different as night and day. And so are the cultures. While in Mexico last year, we saw a car that had missed a turn and was teetering halfway off a cliff on a main highway. All traffic stopped in both directions and everybody poured out of their cars to help. Ten guys risked their lives by standing beneath the front of the car and holding it up. Then a bunch of other guys found a huge polypro line and tied it from the car to the back of a fully loaded transit bus that had turned around to position itself to give a tow. Engines roared, the bus throbbed up and down, the men grunted as they pushed — and suddenly the car was back on the main road. Everybody ran back to their vehicles and took off as though nothing had happened. No police or highway patrol was involved.*

### ↑↓THEY VIRTUALLY ESCORT BOATS TO THEIR DEATH

Over the period of years that I lived aboard my Columbia 43 in the Monterey Harbor, I witnessed the beaching of several boats that had come adrift from their outer harbor moorings. Twice I watched a Coast Guard boat stand by and virtually escort the drifting boat into the line of breakers. They had plenty of time to prevent the beachings and consequent loss of the boats — which weren't derelicts. I asked a Coast Guard buddy why that was, and he gave the same response about saving people, not boats.

I applaud the Coast Guard for the much-publicized and truly heroic rescues they've done. But I'm blown away and disappointed at their policy to stand by and do nothing in situations like *JoJo's*, where they could have easily prevented the Catalina from going on the beach. If they had a life-threatening event going on somewhere else at the same time, then I would understand their prioritizing that. Instead, they were acting in an inspection role, probably to document any environmental damage so more fines could be dumped on boat owners and insurance companies.

Dave Morris  
*Kaveinga*  
Monterey

### ↑↓ISN'T THIS WHY VESSEL ASSIST EXISTS?

I'm sure the Coast Guard policy is to save people, not boats. If they started getting involved in salvage work, they would start getting hit with claims. Why did you tow my boat that way? Why didn't you just wait for the next high tide? My boat would have been fine if only you hadn't (fill in the blank).

Isn't this situation exactly what Vessel Assist is for? Call the Coast Guard and tell them you're stuck. Call Vessel Assist and let somebody very experienced help with what they deal with all the time.

Kevin R. Crisp  
Planet Earth

*Kevin — Vessel Assist was called. JoJo was breaking up on the beach before they could arrive from Santa Cruz.*

**New Member Showers and Laundry Facilities Now Open!**

# Emeryville Marina

ON THE BAY

## NEW SLIPS!

Now taking reservations for 40' to 60'

When you call Emeryville Marina Home...  
...call this your backyard!

**Free Wi-Fi and Video Surveillance**

Slips from 20-65 ft  
Full Amenities - including  
Fuel Dock & Pumpout Station

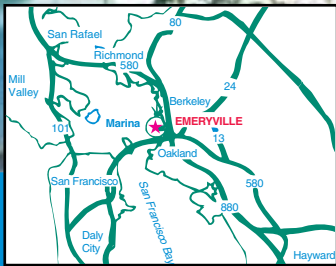

**MARINAS**  
International

(510) 654-3716  
www.emeryvillemarina.com

**SAVE**  
on North Sails  
quality, durability  
& performance!

**NORTH SAILS**  
**direct**

It's easy to measure your own boat and SAVE on the world's best cruising and racing sails. Log on to [northsailsdirect.net](http://northsailsdirect.net) or call 888-424-7328.

Free tape measure with every order!

# Martyr

The World's Premium Marine Anodes

**STREAMLINED SHAFT ANODES\***    **RUDDER ANODES\***    **LIMITED CLEARANCE SHAFT ANODES**

Two Stainless Steel Hardware Options  
To Choose From ... **Slotted Head**    **Allen Head**  
Comes with lock washers & plastic bolt retaining washers

**\*Available in all 3 alloys**

<b>M1</b>	<b>ZINC</b>	For Salt Water ONLY
<b>M2</b>	<b>ALUMINUM</b>	For Salt & Brackish Water
<b>M3</b>	<b>MAGNESIUM</b>	For Fresh Water ONLY

T: 1-604-940-2010    F: 1-604-952-2650  
sales@martyranodes.com    www.martyranodes.com

## Not Using Your Boat?



**STORE IT**

## Want to Sell Your Boat?



**STORE IT**

## Want to Dry Out Your Boat?



**STORE IT**

## Leaving the Country?



**STORE IT**

## Want to Save Money?



**STORE IT**

**DRY STORAGE**  
**\$4.00/ft**  
**Power & Sail**



*Happy New Year from your friends at*

**NAPA VALLEY MARINA**

1200 Milton Road • Napa, CA 94559

(707) 252-8011 • Fax (707) 252-0851

[www.napavalleymarina.com](http://www.napavalleymarina.com)

Marina • Boatyard • Chandlery • Brokerage

Dealers for  
**YANMAR**

**Interlux**  
yachtpaint.com

Distributors for *Brownell*  
Boat Stands

## LETTERS

### ↑↓ WHY FOLLOW IN JOJO'S FOOTSTEPS?

It seems to me that the Livengoods have it backwards. The Coast Guard didn't put *JoJo* on the reef, they did. And then they got ticked off that the Coast Guard didn't want to follow in their footsteps by putting their million dollar rescue boat on the same reef.

Arjan Bok  
Rotkat, Lidgard 43  
San Francisco

### ↑↓ SAILING IS FOR SELF-RELIANT INDIVIDUALS

I'm torn about the *JoJo* situation. On the one hand, my heart goes out to the owners, as losing your boat is a bitter pill to swallow. On the other hand, blasting the Coasties for not pulling his fat out of the fire makes Mr. Livengood sound like a petulant child. Rescuing the property of every ill-prepared and/or unlucky sailor is not the Coast Guard's job.

I don't buy the Livengoods' 'saving the environment' argument either. First, it appears *JoJo* was recovered with fuel tanks intact. Good on that. Secondly, there is a good chance that if our nanny government had extended the safety net to the extent Mr. Livengood was demanding, it would only encourage many more unprepared sailors to put to sea loaded with diesel and just looking for a good place to run aground and foul the waters.

I'm willing to give Mr. Livengood the benefit of the doubt, as people under stress say and do things they sometimes later regret. Hopefully this will be the case with him. If not, I would suggest he take up another pastime. Sailing, in my humble opinion, is for self-reliant, competent individuals who are aware of the risks they are taking — and who would *never* whine about people not helping them enough.

Russ White  
CLOD

### ↑↓ THE WRONG TIME OF YEAR AT STILLWATER COVE

*JoJo* was ill-prepared and not knowledgeable of the conditions at Stillwater Cove. Furthermore, she was brought there at the wrong time of year and in the wrong conditions. This wasn't the first *JoJo* incident either.

Name Withheld by  
Request



Conditions were calm when '*JoJo*' ran into trouble in Stillwater Cove.

NWBR — *There didn't seem to be anything inherently wrong with taking a boat into Stillwater Cove on October 20. According to Coast Guard records, the wind was 10 knots out of the north and the swell just one foot.*

### ↑↓ WHEN DID THEY STOP SAVING VESSELS?

Hell yes, the Coast Guard should have done more! What an unnecessary tragedy. How did the Coast Guard's mission ever get away from saving both people and vessels?

Doug Thorne  
Tamara Lee Ann, Celestial 48  
San Francisco





"The World Leader in  
Outfitting Performance Sailors."

BLOG

THE RACK

SEARCH

Apparel

Line

Hardware

One Design Parts

Accessories

Team Gear



www.APSLTD.com

800.729.9767

## JOIN US FOR OUR MIDWINTER SERIES

★ ALL BOATS WELCOME ★

January 16-17 & February 20-21

Post-Race Festivities – Drink, Dine  
and Dance to the Left Coast All-Stars!

Information & Sign-Up at: [www.cyc.org](http://www.cyc.org)

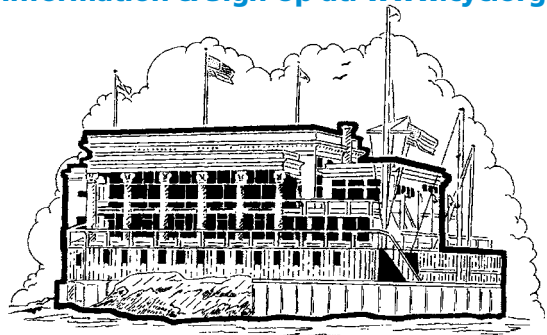

### Corinthian Yacht Club

OF SAN FRANCISCO

43 MAIN, TIBURON, CA 94920 • (415) 435-4771

Visit our website: [www.cyc.org](http://www.cyc.org)

## Romancing The **SLOOP**

*Cruising in a sailboat can be romantic and fun...  
but neglecting her can be as dangerous as an Argentinean mistress  
who has been ignored.*

February Workshop:



### The Shocking Truth *about* Electricity on Boats

with **GUY STEVENS**

February 9, 16, 18, and 20  
Coral Reef Inn & Suites, Alameda

This workshop will help you:

**BUY** a boat with a safe electrical system

**UPGRADE** the electrical system on your current boat

**MAINTAIN** your darling so she will love and protect you

Saltwater and electricity are a deadly mix ... but many boats feature neglected, poorly installed, or dangerous electrical systems. Guy Stevens, a veteran cruiser and boat surveyor, will give theoretical and hands-on instruction on how to work with, upgrade & maintain the electrical system on your cruising sailboat.

To register:

510-629-6525 or

[RealWorldCruising.com](http://RealWorldCruising.com)





## Come to San Diego's One-Stop Boating Marketplace!

- See a wide selection of new and used power and sailboats
- Check out the latest marine gear, accessories, services and more
- Convenient parking and shuttle service



### Hours

Thursday: noon - 6 p.m.  
Friday: noon - 6 p.m.  
Sat. & Sun 10 a.m. - 6 p.m.

### Admission

\$10 for adults  
Children 12 and under  
are FREE

[www.bigbayboatshow.com](http://www.bigbayboatshow.com)

for directions, parking, information and more!

**SAN DIEGO**  
SUNROAD MARINA  
**BOAT SHOW**  
January 28-31, 2010

## LETTERS

*Doug — The Department of Transportation handed down a very decisive policy change in 1982, one that dictated that the Coast Guard leave all towing and salvage to private businesses. The Coast Guard now only saves boats in cases where they have to in order to save lives.*

### ↑↓ CONDUCT UNBECOMING

Yes, the Coast Guard could have done more. I would expect that, once on the scene, they would *want* to do everything possible, not just sit there and watch. Disgraceful.

Steve & Edie Hollen  
Andalucia, Irwin 37  
Yorba Linda

*Steve and Edie — You have to distinguish between what the Coast Guard crew might have wanted to do, and what they were legally and physically able to do. As you'll read later in this issue, there's another side to the story.*

### ↑↓ "I SECOND THE SECOND ANCHOR IDEA"

All prepared cruisers should carry two anchors. What were the wind conditions like that day? Stillwater is a graveyard in a southerly. I would be hesitant to enter during the winter months.

Tim Stapleton  
San Rafael

*Tim — Weather wasn't a factor on October 20. It was blowing 10 knots out of the north and the sea was reported to be one foot.*

### ↑↓ IT'S ALL ABOUT JURISDICTION

Absolutely the Coast Guard should have done more, especially after the boat floated free. The Coast Guard could have shot a line to them and assisted with a tow. What a crime to see unnecessary damage.

Steve Morrow  
Westbrook, ME

*Steve — The Coast Guard doesn't do 'beach rescues' or 'sand rescues' because those are out of their jurisdiction. Once you hit something hard, you belong to the coastal incident folks.*

### ↑↓ DEPTH LIMITATIONS

Absolutely the Coast Guard should have done more! To arrive on scene without the proper equipment to at least attempt a tow or to try to pull the boat free is disheartening! After all, they had a shallow draft boat compared to the 5'3" draft of the Catalina 30. I know, I have one! And especially with an incoming tide! I would like to think that the already exorbitant tax dollars we pay would go for more than just a good look!

Stuart Gregor  
Solitude, Catalina 30  
Stockton

*Stuart — JoJo was a Catalina 36, a design which, depending on the keel, can draw as much as 5'11". The 47-ft motor lifeboat draws 4'6". The Coast Guard's navigation rules require that the 47-footers operate only with three or more feet of water beneath their keels — making a total of 7.5 feet of water.*

*The coxswain of each 47-footer also has to do a continual risk analysis of every rescue situation. Other risks in Stillwater included extremely heavy kelp and known rocks and reefs in the area. Most importantly, the Coast Guard can — in most*

# Wright Way designs

Custom Yacht Interiors

presents a  
**FREE SEMINAR**  
Yacht Interior Trends 2010

Define your style

Are You a  
**Creature of Comfort?**  
**A Daring Seeker?** or  
**Straddler?**

Featured topics include:

- Fabrics and Carpeting
- Designing on a Dime

**THURSDAY, JANUARY 28**

at the

*Pasta Pelican Lounge*

2455 Mariner Sq. Dr., Alameda



Deborah Wright

Time: 5:30-6:00 No-Host Bar

Presentation: 6:00-7:00 p.m.

Space is limited, please reserve yours by January 20

Email: [wrightwaydesigns@hotmail.com](mailto:wrightwaydesigns@hotmail.com)

Phone: (510) 908-3939

[www.wrightwaydesigns.com](http://www.wrightwaydesigns.com)

## Advanced LED Navigation Lighting



Super Bright  
Waterproof  
Multiple Color Configurations  
Excellent Viewing Angles  
Lifetime Warranty

Available at:  **SVENDSEN'S  
MARINE**

Call or visit our website to learn more about our quality lighting products.

[www.LunaseaLighting.com](http://www.LunaseaLighting.com)  
1.800.272.0170

RoHS  



# West Marine® Rigging Service

## Your Sailing Resource!

- Custom-Rigging
- Specialty Hardware
- Technical Apparel

See our  
trailer at Key West  
Race Week



 **RONSTAN**

 **FSE ROBLINE**  
WORLD CLASS YACHTING ROPES

 **POWERLITE**  
PSD RIGGING

 **samson**

 **Johnson**  
Marine Hardware

 **NEW ENGLAND ROPES**

 **Hayn Marine**

 **holmatro**  
marine equipment

 **HARKEN**

 **FORESPAR**

 **SmartRigging**  
The Intelligent Choice

 **factor**  
FURLING SYSTEMS

Contact us for all of your Rigging Needs!  
**888-447-RIGG**

or visit our Onsite Rigging Locations in:

**Alameda, CA**  
730 Buena Vista Ave.  
(510) 521-4865

**San Diego, CA**  
1250 Rosecrans St.  
(619) 255-8844

**Seattle, WA**  
1275 Westlake Ave. N  
(206) 926-0361

**Annapolis, MD**  
113 Hillsmere Dr.  
(410) 268-0129

**Rock Hill, SC**  
860 Marine Dr.  
(803) 909-6280

**Ft. Lauderdale, FL**  
2300 S. Federal Hwy.  
(954) 527-5540

[westmarine.com/rigging](http://westmarine.com/rigging)

# AIS Made Easy!

Latest, most cost-effective collision-avoidance solution

AIS (Automatic Identification System) receivers enable AIS-capable chart plotters and navigation software to see other vessels. AIS transponders allow other vessels to see you.

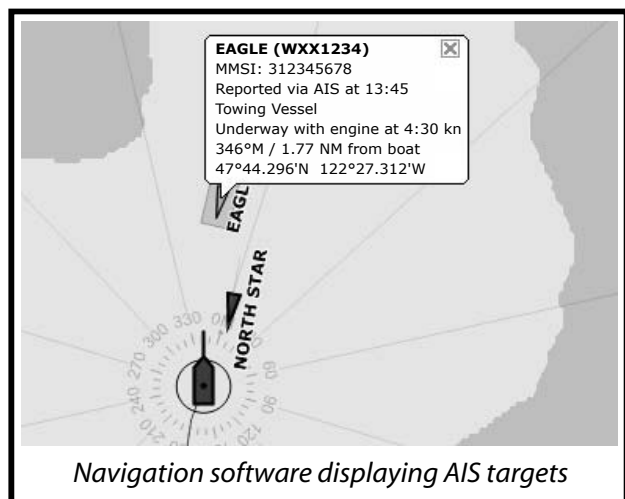

Navigation software displaying AIS targets

Milltech Marine offers complete, low-cost AIS solutions. Visit our web site for information on:

- ✿ AIS Receivers - featuring the Comar AIS-MULTI
- ✿ AIS Transponders - including Class B AIS
- ✿ Navigation Software
- ✿ Antennas, cables and other accessories



Order any product online and use coupon code "LAT38" to get free shipping in the U.S.

For more information contact:



(866) 606-6143  
www.MilltechMarine.com

## LETTERS

cases — rescue boats only if it's necessary to save lives. That wasn't the case in the JoJo situation. If you object to these policies — and we have certain issues with them — don't yell at the Coast Guard, yell at their bosses, meaning Congress and Homeland Security. For the record, the policy of not saving boats was instituted more than 25 years ago.

### ↑↓ THE POLICY NEEDS TO BE CHANGED

Without hearing the Coast Guard skipper's version, it is difficult to judge. But if it's a Coast Guard policy to only preserve life and never assist a boat, the policy would seem too rigid. If the Coast Guard could easily have thrown *JoJo* a line, but didn't do so because of policy, then the policy needs to be changed.

From the one side you presented in the article, it seems that there was a lot of potential damage to the environment, and the loss of a boat could have been prevented by more earnest Coasties. You can bet that had I been there with my boat and my dink, I'd have gotten out my 300 feet of half-inch line I use for my Angel Island mooring. I then would have tried

to pull *JoJo* off — as would most of the sailors I know around here.

From reading *Latitude*, I seem to recall a lot of stories about the Mexican Navy's pulling American boats off the rocks, and a lot of other tales about the navies of little countries in the South Pacific getting involved with saving boats on reefs.

So we need to hear the rest of the story. If the Coast



COURTESY JOJO

**Don't scream at the Coast Guard about the policies — scream at Congress.**

Guard was not responsive due to fear of litigation, then we need a maritime 'Good Samaritan' law that covers the situation for them as well as other boaters.

This is an important topic. Glad you brought it up.

Bruce Adornato  
Amelia, Krogen 42  
San Francisco

Bruce — The irony is that, no matter how much the crew of the 47-footer might have wanted to help save the boat, it would have been against the law. Does that mean that private citizens could have done more to save the boat than the Coast Guard? It's weird, but the answer is yes.

What most boat owners don't realize is that the Coast Guard does only 'maritime rescues'. If a boat hits the bottom, the responsibility then transfers to a coastal incident group made up of the fire department, police, sheriff, lifeguard, EMS and others. Why didn't they show up? Station Monterey Commanding Officer Lt. Michael Kahle told *Latitude* it was because *JoJo* originally gave them a wrong position, indicating they were north of Stillwater Cove. "Had we known they were in Stillwater Cove from the beginning," says Kahle, "we would have alerted the coastal incident team right away." We would have surprised if the C.I. team doesn't have access to inflatables



Beautiful 20 acre greenbelt park in the Heart of the Delta

- Up to 30' no power/inside tie @ \$4.50 per foot
- 30'- 50' berths @ \$5.50 per foot
- Home of Andreas Cove Yacht Club

Located on Seven Mile Slough, just off the San Joaquin River

1550 W. Twitchell Island Road • Isleton, CA 95641  
916.777.6055 • [www.owlharbor.com](http://www.owlharbor.com)

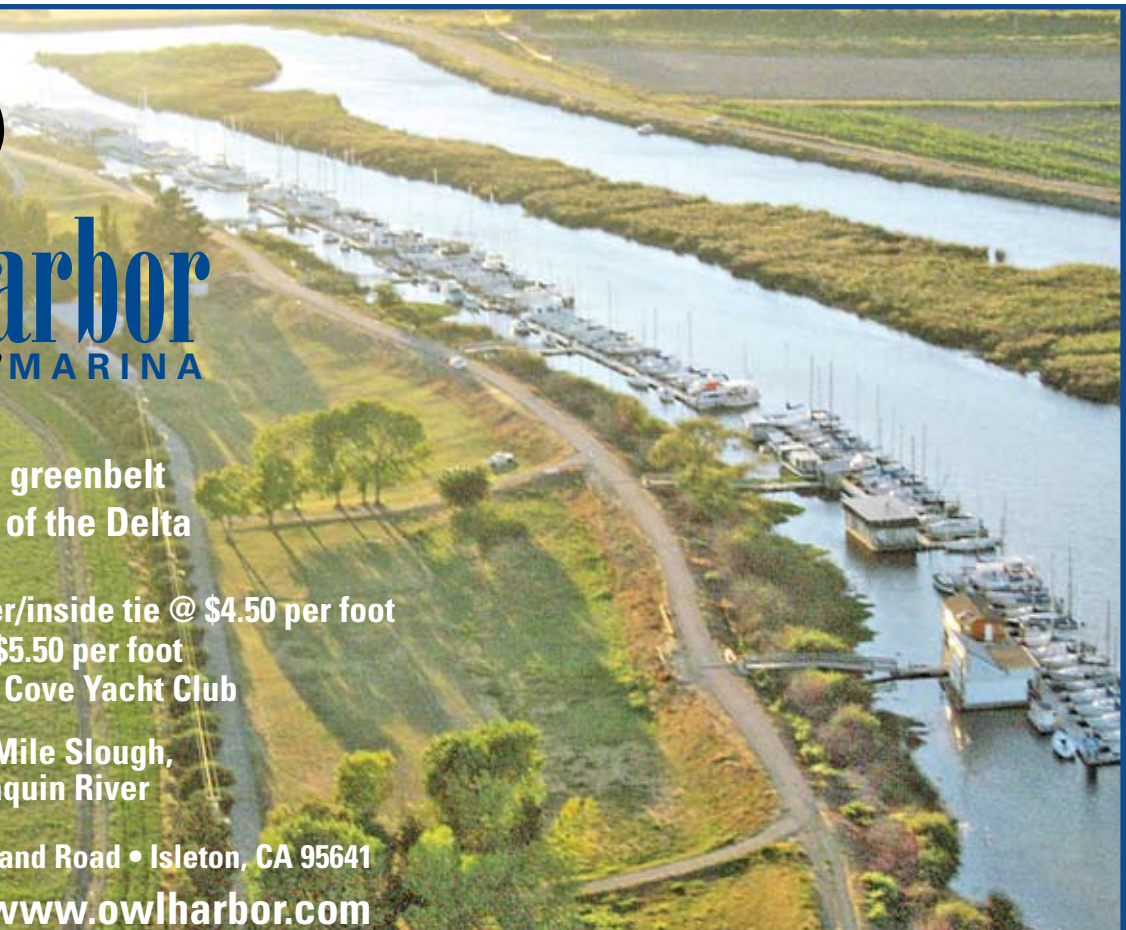

SEASHINE

**Service of the Month**

**BILGE CLEANING**

Family friendly, eco-friendly, weekend friendly.  
A professionally cleaned bilge will help everyone enjoy more time aboard.

**ADDITIONAL SERVICES**

Polishing • Detailing • Maintenance  
Washdown • Carpet & Cushion Cleaning

**Fully Insured & Marina Approved**  
**Serving the Bay Area Since 1986**

Call now for a Free Estimate

**510 428-2522 or 415 457-6300**

**[www.seashine.net](http://www.seashine.net)**

**PortVisor™**

Keep ports open in the rain

- Air out cabin and head
- Maintain visibility
- Install easily, without tools
- Enjoy life aboard more often



**CHECK OUT OUR NEW SIZES AND PRODUCTS!**



Many sizes for aluminum, bronze, stainless, and plastic portholes.  
Made from clear UV-resistant Lexan with bronze tint.

**[www.seaworthygoods.com](http://www.seaworthygoods.com)**

*Smart Stuff. Smart Boats.*

**(941) 448-9173**

# MORE SAVINGS! MORE CLASSES!

## Basic Keelboat (101) - \$645

Jan 13,14,15	Jan 25,26,27
Jan 16,17,23	Jan 30,31 & Feb 6
Jan 23,24,30	Jan 31 & Feb 6,7
Jan 24,30,31	Feb 6,7,13

## Basic Coastal Cruising (103) - \$845

Feb 14,20,21	Mar 17,18,19
Feb 20,21,27	Mar 21,27,28
Feb 24,25,26	Apr 11,17,18
Mar 7,13,14	Apr 14,15,16

## Bareboat Chartering (104) - \$1045

Mar 7,13,14	Apr 25,& May 1,2
Mar 14,20,21	Apr 28,29,30
Mar 21,27,28	
Apr 11,17,18	
Apr 18,24,25	

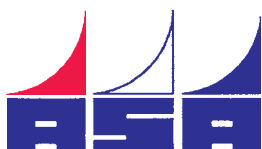

## Winter Special!

Take **\$200** off any of the above courses\* or take advantage of our 3 Class Package (101,103 & 104) at

**\$1895.00**

Call us for details! (510) 232-7999  
www.TradewindsSailing.com



## LETTERS

and Jet Skis, either one of which could have rushed a line out to the other boat.

### ↑↓ IS IT REALLY OPPOSITE IN THE U.S.?

In Canada we're taught to issue a *mayday* when the boat is in danger of sinking, but not for medical purposes. Is it really the opposite in U.S. waters?

Randy Brown  
Canada

Randy — Yes, it is the opposite.

### ↑↓ THE COAST GUARD IS NOT AAA FOR THE SEA

Let's be clear. The Coast Guard is a Safety of Life at Sea organization. They are not meant to be, nor should they be, a maritime version of AAA. It's difficult enough saving what counts, which are lives. Saving one's ship is the skipper's responsibility.

Jeff Berman  
*Perseverance*, Catalina 36  
San Francisco

### ↑↓ SAILORS SHOULD BE SELF-RELIANT

It's a sad situation for sure, but would it have been possible for the sailors to row a rope over to the Coast Guard and have the boat towed to deeper waters? It's hard for me to blame the Coast Guard for anything. We're not yet a complete nanny state, and part of being a sailor is to be as self-reliant as possible.

And while the boat was lost, no one was hurt, so a new adventure begins with the insurance company.

Richard Frankhuizen  
Folsom

### ↑↓ THE CAPTAIN WAS AT FAULT

The captain was at fault. His windlass did work. Plus, he could have motored back out to deeper water. Besides, his VHF should have had DSC. The Coast Guard most likely did not realize they had to do a shore rescue when they responded. He was responsible for his vessel and his crew.

Jim Peta  
*Kids Money*, Catalina 30  
Oakwood, GA

Jim — As best we can understand it, if JoJo had given their correct position at Stillwater Cove, the Coast Guard would have immediately turned the rescue and possible salvage over to the coastal incident team.

### ↑↓ HELLO NEUMANN!

Wow, this a tough one. I've heard many times that the Coast Guard will not tow boats. But I've also read stories about their having done so. I'm left completely confused as to what to expect in terms of assistance from them. After reading about the JoJo incident, I think if I were in a situation where nobody's life is in danger, my first call might be to Vessel Assist rather than the Coast Guard. I'm also surprised there was no RIB on the Coast Guard motor lifeboat. That would seem to really limit what assistance they could provide. I'd love to hear the Coasties' side of this story.

Jennifer Neumann  
Planet Earth

Jennifer — The Coast Guard tells us that, for the most part, they can tow boats only if it's what is necessary to save lives.

**REPAIR  
REPAIR  
REPAIR**

**ROOSTER SAILS  
A REPAIR LOFT**

**NOW AT  
GRAND  
MARINA**

**YOUR ROLLER  
FURLER UV COVER  
SPECIALIST**



**ROOSTER SAILS**  
2021 Alaska Packer Place, Box 18, Alameda  
**(510) 523-1977**  
[www.roostersails.com](http://www.roostersails.com) • [rui@roostersails.com](mailto:rui@roostersails.com)  
Open M-Th 9-6 • Fri 9-5 • Sat by appt.  
Owned and Operated by Rui Luis • Experienced Sail Repair and Fabrication  
**NOW OFFERING NEW CRUISING SAILS!**  
SAIL REPAIR SPECIALISTS • COMPETITIVE RATES • RECUTS • CONVERSIONS

**HIRSCHFELD YACHT LLC**  
Offering the *best value* in the Bay Area for:  
Marine Repair, Service, and Repowers



**BETA MARINE WEST**  
39 Libertyship Way, Sausalito, CA 94965  
[www.engineerite.com](http://www.engineerite.com) • [www.betamarinewest.com](http://www.betamarinewest.com)  
**(415) 332-3507**

*We are the exclusive distributor of  
Beta Marine diesel engines and generators in California.*

**SVENDSEN'S  
MARINE**

Your Northern California Distributor For

**Dometic** | **Marine  
Sanitation  
Products**

**Sealand  
BRAND**

Including VacuFlush®, Traveler®,  
Flush and Forget®, Concerto®,  
SaniPottie®, and TankWatch®.



Dometic/SeaLand is the leader in marine sanitation products, with a wide range of toilets, vacuum generators, integrated toilet/tank systems, holding tanks, accessories, and more.

You can find Dometic/SeaLand products at Svendsen's Marine in the Alameda Marina (1851 Clement Avenue, 510.521.8454) and at these fine stores:

<b>San Francisco Yacht Service</b> 540 Cordova St., San Francisco 415.303.3407	<b>Outboard Motor Shop</b> 333 Kennedy St., Oakland 510.533.9290
<b>San Francisco Boat Works</b> 845 China Basin, San Francisco 415.626.3275	<b>Keefe Kaplan Maritime, Inc.</b> 530 W. Cutting Way, Pt. Richmond 510.235.5564
<b>Alan McDonell's Boat Guys</b> 909 Marina VIIg. Pkwy #220, Alameda 510.393.9168	<b>Bayside Boat Works</b> 2360 Marinship Way, Sausalito 415.332.5744
<b>The Boat Yard @ Grand Marina</b> 2021 Alaska Packer Place, Alameda 510.521.6100	<b>Delta Marine Services</b> 1302 W. Fremont St., Stockton 209.463.0384
<b>Marine Emporium</b> PO Box 520, Bethel Island 925.684.2330	<b>Marine Equipment Installers</b> 1815 Clement Ave. #14, Alameda 510.205.1695
<b>Napa Valley Marina</b> 1200 Milton Rd., Napa 707.745.1641	<b>Tim Wiest Yacht Service</b> 700 Alamo Drive, Vacaville 707.447.5163

**Svendsen's Marine**  
1851 Clement Ave., Alameda | 510.521.8454

# BLUE WATER YACHT INSURANCE

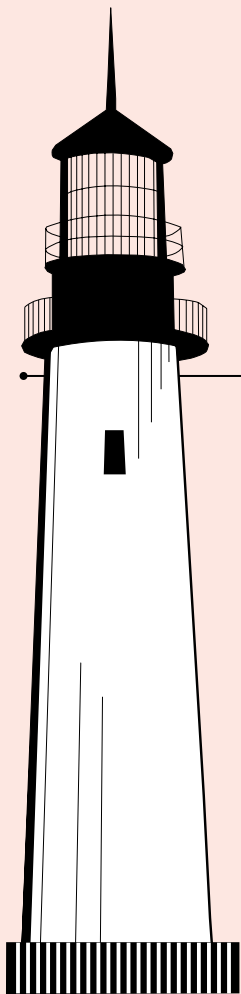

Blue Water Yacht Insurance covers more active cruising boats than any other marine agency in the Western Hemisphere, and is the leading innovator of insurance products for the offshore sailor.

## Our Insurance Programs Provide:

- Crew of two anywhere
- Worldwide Navigation
- Hawaii
- Caribbean
- South Pacific
- Mexico
- Charter Boats
- Multihulls
- Liveboards
- Racing Boats

## Quality Rated Insurance Companies

Boats aged 1 to 40 years • "Agreed Value"  
"All Risks" • "New for Old" replacement partial losses  
Hulls valued \$50,000 to \$2,500,000

## Worldwide Health Insurance

International and USA health insurance plans  
at affordable prices.



BLUE WATER  
INSURANCE  
JUPITER, FLORIDA • USA

Call Toll Free  
**(866) 463-0167**  
Fax: (866) 795-3707  
sales@bluewaterinsurance.com

Quote requests  
Visit our website

[www.bluewaterinsurance.com](http://www.bluewaterinsurance.com)

## LETTERS

*Or if the boats are full of drugs or illegal aliens. Vessel Assist was called, but couldn't make it in time.*

### ↑↓ **DEPTH ASIDE, THEY COULDN'T HAVE HELPED**

How deep was the water JoJo was in? Did the Coast Guard vessel have enough water to go in and get her?

Bill Clune  
ex-Coast Guard

*Bill — Depending on the keel, Catalina 36s had a draft of either 4'5" or 5'10". Since JoJo was hitting the bottom when the Coast Guard arrived, the depth was no more than perhaps 5'5". A 47-ft motor lifeboat draws 4'6". Coxswains are forbidden to operate the 47-footers in less than 7'6" of water.*

*But don't get distracted. The real issue is that policy precludes the Coast Guard's performing salvage operations. Further, by touching bottom, the responsibility for the incident should have gone over to the coastal incident team. They didn't show up, apparently because JoJo had initially given a position that indicated they were not at Stillwater Cove.*

*For more on this story, see page 108.*

### ↑↓ **NO WAY IS THE HA-HA HARDER THAN THE 1500**

Anyone who claims that the Ha-Ha is more difficult and hazardous than the Caribbean 1500 should be examined forthwith for mental competency. Or perhaps just for memory loss. The list of boats damaged and lost in the 1500 is a long one, arising from the need to make a North Atlantic passage across the Gulf Stream on or after November 1. Participants are almost sure to get hit by one of the lows that form off Cape Hatteras, and there's always the chance of a late season tropical storm. And for those who say there's no place to hide in the Ha-Ha, try being 350 miles east of Cape Henry in the middle of a 40- to 50-knot gale. I'm a vet of the '97 Caribbean 1500.

Bob Schilling  
Tuckernuck, Cherubini 44  
Long Beach

*Bob — We're not sure what we might have written to give the impression that we think the Ha-Ha is more difficult and hazardous than the Caribbean 1500, because we've often stated the opposite in print. In fact, we often note how lucky we California sailors are because it's so much easier for us than our East Coast brethren to get to the tropics. After all, our winds to the tropics are almost always from aft and light to moderate, plus we have numerous great places to take shelter from the prevailing conditions along the Baja coast. The 1500 is twice as long, the fleet faces stronger winds and bigger seas from a variety of directions, and other than Bermuda, there is no place to hide.*

*Steve Black, who has organized the 1500 all these years, would be quick to deny your suggestion that the 1500 is some kind of destruction derby, but there is no doubt that it's harder and more challenging than the Ha-Ha.*

*In a typical month, we receive a tremendous volume of letters. So if yours hasn't appeared, don't give up hope.*

*We welcome all letters that are of interest to sailors. Please include your name, your boat's name, hailing port, and, if possible, a way to contact you for clarifications.*

*By far the best way to send letters is to email them to richard@latitude38.com. You can also mail them to 15 Locust, Mill Valley, CA, 94941, or fax them to (415) 383-5816.*



# LOCH LOMOND MARINA

**Completely Rebuilt Marina • Gas & Diesel Fuel Dock  
Free Pump Out Station • Modern Launch Ramp  
Guest Slips Available • Marine Mechanical Boat Repair  
Arena Marine Supply Store • Loch Lomond Market**

**110 Loch Lomond Drive, San Rafael, CA 94901**

**Phone: (415) 454-7228 • Fax: (415) 454-6154**

**www.lochlomondmarina.com**

**Harbor Master – Pat Lopez • pat@lochlomondmarina.com**



## KISSINGER CANVAS

*Marine Canvas & Interiors*  
STEVEN KISSINGER  
**(925) 825-6734**  
*Covering the Entire Bay Area*



- Biminis
- Boat Covers
- Cushions
- Sail Covers
- Headliners
- Awnings

## DODGERS

Side handrails and window covers included.

## OPTIONS

Aft handrail, dodger cover, sailing bimini.

*Free Estimates and Delivery*

## SAUSALITO

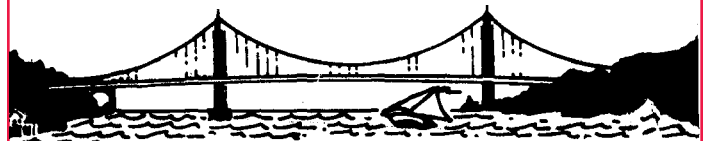

## LIST MARINE INC.

- Full service engine shop
- We service all makes
- Dockside facilities
- Mobile service trucks

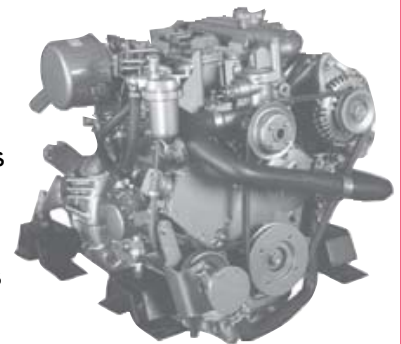

**YANMAR**  
marine

P.O. BOX 2008 / 69 LIBERTY SHIP WAY • SAUSALITO, CA 94966  
Adjacent to Schoonmaker Pt. Marina

**415•332•5478**

**www.listmarine.com**

# LOOSE LIPS

As referenced in *Letters*, ever since it was learned several months ago that Anderson's Boat Yard was closing, the rumor mill has been churning as to what would become of that prime piece of Sausalito real estate.

Turns out Keefe Kaplan Maritime, Inc. (KKMI) now has a lease on the facility, with grand plans to make it the most environmentally-friendly haulout operation in the Bay Area. According to KKMI co-owner Paul Kaplan, a berm will be built around the entire 1.5-acre facility so that in periods of extremely high tides and storms, sea water will be kept from washing into the yard, and conversely, yard contaminants will be kept from seeping into Richardson Bay.

Additionally, a first-of-its-kind Travelift has been ordered which will be built of recycled steel and will operate on biodiesel, with biodegradable fluids flowing through its hydraulic lines. Also, two custom-built industrial filtration systems will cleanse both runoff water and washdown water, using a settling process and absorptive minerals, rather than chemicals.

"Because our business is involved with all sorts of toxic materials," says Kaplan, "we have a high level of responsibility to the environment. The last thing we want is to play any part in polluting the Bay." The permitting process is ongoing, but the new facility is expected to begin hauling boats in March. New construction should be finished next summer, making room for additional tenants who'll offer a variety of marine services.

## Phishing for friends.

"Dear Friend, You have won the National Nigerian Lottery! To collect your \$1 million prize, you only have to send us \$5,000 to expedite its distribution. . . ."

If you have an email address, you've probably received similar requests which attempt to trick you out of your hard-earned money. Most of us simply trash them. But what would you do if one of your best friends sent you a private message through Facebook asking for help? If you're any friend at all, you might fall victim to a new scam.

One sailor we know was defrauded after a close friend contacted him through the popular social networking site. "He said he'd been mugged in London," the sailor said. "He told me they took everything, and that he was scared and needed money to get home."

Worried about his friend, but also wary of being duped, the sailor asked a series of personal questions to verify his buddy's identity: What's my wife's name? How did I meet her? Where did I propose to her? What did you give me last year? "He responded immediately with the right answers, so I wired him the money," the sailor said. He believes the 'friend' researched his own postings to get all the answers before contacting him.

It wasn't until the sailor got home to a request for more money that he started to worry the whole thing was a scam. He insisted his friend call him, but the friend gave him the number of his 'hotel' instead. "The guy who answered the phone said he was aware of the situation but that my friend had just stepped out," he recalls. "I asked him to describe him, and when he got it completely wrong, my stomach dropped."

It turns out, his friend's Facebook account had been hacked. Unfortunately, this new form of identity theft is costing compassionate Facebookers thousands of dollars, and there's little that can be done to stop it. To protect yourself, experts recommend changing your passwords often and limiting the amount of personal information you post. Also insist that any friends who ask for large sums contact you by phone.

The most despicable thing about the scheme is not that these hackers are stealing money, but that they're feeding off their victims' compassion and leaving them feeling foolish for it.

**MARINERS**  
GENERAL INSURANCE GROUP

Now with six offices offering you local insurance service and global insurance coverage.

**SEATTLE**  
(800) 823-2798 • (206) 281-8144  
Fax (206) 281-8036

**NO. CALIFORNIA**  
(800) 853-6504 • (650) 373-0595  
Fax (650) 548-1585  
email: boomeins@aol.com  
Lic. # 0A99058

**L.A./ORANGE COUNTY**  
(800) 992-4443 • (949) 642-5174  
Fax (949) 642-0252  
Lic. # 0D36887

**SAN DIEGO**  
(800) 639-0002  
Fax (619) 226-6410  
Lic. # 0A96346

**BRADENTON, FLORIDA**  
(800) 914-9928  
Lic. # E051940

**New!**  
**PUERTO VALLARTA**  
(949) 274-4111

**ATTENTION CRUISERS!**  
MEXICAN LIABILITY INSURANCE ONLINE

**50**  
YEARS OF SERVICE  
1959-2009

**ASK ABOUT OUR NEW RACING SAILBOAT PROGRAM!**

**It's a Mariner's Fact:**  
Even the best equipped liferaft can often be inadequately supplied. A ditch bag with additional supplies quickly accessible in 'abandon ship' situations is a great idea.

**www.marinersins.com**

"The elegantly simple, single-sail Wyliecat 30 makes the fun of sailing instantly accessible."

Sailing Magazine

Experience the high performance and simplicity of the Wyliecat design.

**WYLIECAT 30**  
Sailing In The Right Direction

Models: 17 | 30 | 39 | 48 | 65 | 66

www.wyliecat.com • Tel: 916-743-7194



**HAPPY  
NEW YEAR!**



**HERE'S TO  
FAIR WINDS IN 2010!**

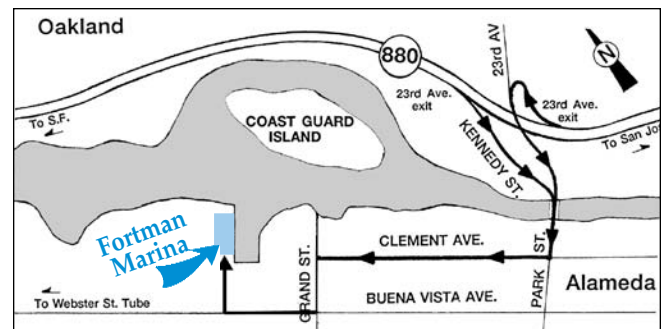

- Sheltered Alameda Location
- Competitive Rates
- Home of the Alameda Yacht Club
- Home of Cruising World Pacific

1535 Buena Vista Ave., Alameda, California  
**(510) 522-9080**

For directions and rates go to:  
**www.fortman.com**

## Ultra Anchor

**Quickest Setting!  
Highest Holding!**

Quickline USA — Marine Products  
from the World, for the USA

- Highly polished 316L stainless steel
- Self-aligning and self-burying
- Always lands in attack position
- Sets quickly and holds tight in the most challenging conditions

As strong as it is beautiful, Ultra Anchor is produced for the discerning yachtsman who wants *only the best!*

Ultra Anchor's self-righting design is simply better. The shank is hollow, and the lead-filled base keeps the center-of-gravity right at the tip—so when the Ultra Anchor hits the sea floor, it is automatically in penetrating position.

Why settle for a dull galvanized, ineffective anchor? No need, when you can set your vessel apart with Ultra Anchor!



8700 Warner Ave. #110  
Fountain Valley, CA 92708  
Phone: 714-843-6964, Fax: 714-843-6906  
www.quickline.us or sales@quickline.us

# SIGHTINGS

## moonduster's sad end

It's fair to say that cruising the world aboard a sailboat requires taking an endless succession of risks. Longtime bluewater sailors like Wayne Meretsky know this well. During two mostly-singlehanded Pacific circuits aboard his Alameda-based S&S 47 *Moonduster*, he's logged more than 30,000 ocean miles — and has undoubtedly taken innumerable carefully calculated risks.

Sadly, though, the chance that he and his Kiwi girlfriend Neria Brewerton took by cruising the Yasawa Islands of Fiji during cyclone season ended tragically last month. When Tropical Cyclone *Mick* built rapidly, reaching intensity far greater than predicted, the couple

found themselves with no storm-proof anchorage to hide in. After a noble fight, *Moonduster* was driven onto a barren reef, causing irreparable damage to her wooden hull. Fortunately, Wayne and Neria survived the nightmare with only "a few scrapes and bruises," in addition to the inevitable emotional scars.

For several weeks previously, the couple had been exploring the reef-strewn Yasawa Islands of western Fiji with the intention of

crossing to New Zealand around Christmas. On Saturday, December 12, after downloading a GRIB weather file and text summary from Fiji's Nadi Met Service via SailMail, they learned that a low was forming to the north, and Wayne noticed "a slight, shallow bend in an isobar," roughly 100 nm north of their position.

On the next morning's GRIB, that slight bend had clearly formed into a low, and the forecast included a tropical depression warning and a prediction for winds in the 20- to 30-knot range. As planned, the couple upped anchor and headed for Likuliku Bay on Waya Island. "It made good sense as a hideout from the forecast weather," Wayne explained later, "because, as the depression came closer, the winds would clock from the prevailing southeast trades to northerlies and then northeasterlies. Then, as the depression moved past, we could easily move the 3.5 nm to Waya's northern Nalauwaki Bay for the forecast southerlies and westerlies."

They anchored *Moonduster* in 35 feet of water near the middle of the bay, just north of the Octopus Resort, on a 55-lb Delta attached to 200 feet of 5/16" G4 chain and belayed by a 5/8" nylon, three-strand snubber. That afternoon, a Fijian came to the boat and offered a prophetic warning: "Whatcha doin', man? There's a hurricane tonight and you need to go to the marina or you'll be on the beach in the morning." Wayne went ashore and spoke to the Nadi Tropical Cyclone Centre by phone and confirmed that the forecast remained for the storm to pass to the north of them with winds peaking at 40 knots. And even if Wayne and Neria had trusted the well-meaning Fijian's prediction, the closest marina facility was Vuda Point Marina, located 35 miles to the east-southeast. Moving there would have required "sailing upwind, at night through reef-strewn waters with charts that aren't GPS corrected, and through areas that have never been fully surveyed," explained Wayne. "There was simply no way I was going to risk putting the boat on a reef in open water at night, which would mean us in a liferaft in a country with no SAR capability. Staying in Likuliku Bay gave us an escape route to shore — one that we unfortunately needed. Given the forecast, when weighed with the comparable risks, staying put made far more sense than running at night through reef-strewn waters."

continued on outside column of next sightings page

## climbing masts

For all our reservations about the latest crop of teens determined to set the record for being the youngest solo circumnavigator, we have to admit that 16-year-old Jessica Watson's blog makes for some interesting reading. From her waxing rhapsodic about seabirds to her description of climbing the mast to check out her rigging before she gets into the rough stuff, there's no other way to say it: Watson sounds like a sailor.

It's easy to imagine a teenage girl would get lonely at sea — as we went to press, Watson had just celebrated her 65th day

PETER GRANT



In happier times, Wayne and Neria during the Bay of Islands Race Week 2009.



Roy Disney, one of sailing's most beloved and respected supporters, passed away last month. Read our tribute to this one-of-a-kind sailor, seen here aboard his freakishly fast 'Pyewacket 4.5', starting on page 92.



**& pitching fits**

aboard — but that doesn't seem to be the case for Jess. "Lonely is the word for a Friday night with nowhere to go, sitting at home feeling sorry for yourself," she eloquently wrote in her blog ([www.jessicawatson.com.au](http://www.jessicawatson.com.au)). "The difference is that I choose to be out here."

Another 16-year-old would-be record-breaker, Abby Sunderland, is getting closer to taking off on her own quest for the title. The Open 40 *Wild Eyes* her family bought in Florida was shipped to Mexico last month, then brought to her

continued in middle column of next sightings page

**moonduster — cont'd**

With the storm's center expected to pass during the middle of the following day, the couple established an hourly anchor watch to be sure they weren't dragging, all the while assessing the storm's progress. Their checklist included: checking the snubber for chafe and easing when necessary, and recording wind speed, true wind direction, barometric pressure, distance from the anchor measured with the GPS, distance from the shore measured with the radar, and water depth.

Early the next morning, Monday, December 14, the Cyclone Centre was still predicting max winds of 40 knots, but the storm's track was expected to pass right over them. "The mood on board was somber," Wayne recalled. "There were lots of hugs, some tears and an occasional feeling of helplessness." But they did everything they could think of to prepare for the blow, including checking their EPIRBs, personal

continued on outside column of next sightings page



# SIGHTINGS

## moonduster — cont'd

strobes and other safety gear.

At about 0830, the first 50-knot gusts were felt. "We could hear the roar before they struck, and once they were upon us, the boat would both veer wildly and heel heavily. . . the noise, once an unsettling din, had built to a cacophony of sounds best described as howling."

Then one strong gust hit and the "veering motion was accompanied by a deafening bang. I knew immediately that the snubber line on the chain rode had parted." Wayne clawed his way to the foredeck with a replacement snubber, and was shocked to see that the 5/8" nylon line hadn't chafed, but had "parted cleanly" by the sheer force pulling against it. "Seeing that, my stomach clenched and my heart

continued on outside column of next sightings page

## solo girls

homebase of Marina del Rey. Though she has a team of supporters getting *Wild Eyes* ready for a post-Christmas start, the Sunderland family has accepted that the trip may not happen this year. "I will be leaving as soon as we are both ready, not a moment sooner or later," Abby wrote on her blog ([www.abbysunderland.com](http://www.abbysunderland.com)).

Meanwhile, halfway around the world, it looks as if Laura Dekker, 14, sabotaged any chance of her own record bid when she fled the Netherlands last month and



SPREAD: NERIA BREWERTON; INSET: LATITUDE / ANDY

## — cont'd

was ultimately found on St. Maarten. Earlier in the year, Dutch courts ruled that Dekker was too inexperienced to make such an attempt, but were planning to review the decision next summer.

As we put this issue to bed, there was no official word as to her motive for running away from home, or who, if anyone, helped her, but we can't imagine this incident will go far in proving her maturity and decision-making skills to the courts.

— *ladonna*



**Spread, 'Moonduster's final resting place, just above the tide line. Her port side passed over the reef, ripping it apart. Above, she was looking fine at the Tahitian island of Taha'a in '08.**

**moonduster — cont'd**

dropped. It was quickly becoming apparent that losing the boat was a real possibility."

The storm continued to intensify, "In quick succession, we saw 60s and then 70s. I went on deck and slipped the motor in gear and began to hand steer, using the throttle to help hold the boat's bow into the wind." But visibility was so impossibly bad that Neria, viewing instruments belowdecks, had to coach him on which way to turn. "The sound of the wind became simply indescribable," Wayne remembered. "Neither 'freight train' nor '747' do it justice."

Eventually, a "massive gust" forced the bow hard to port. "Even with full throttle and quite a bit of helm, it simply wouldn't come back. I now know that it was at this point that the anchor rode broke, but at the time I didn't understand that. I held the throttle wide open for perhaps 30 seconds and then, through the wind-driven spray, the beach slowly materialized. I caught Neria's eye and motioned towards the surf zone. The end was at hand." He and Neria later learned that the second snubber had also parted, transferring the full force on the rode to the windlass. It gradually back-wound, letting out the remainder of the chain as well as some of the nylon rode that was spliced to it. Under the tremendous load, the nylon eventually chafed through or parted and *Moonduster* was doomed.

The 36-year-old sloop grounded herself on a swath of dead reef, where Wayne and Neria stepped off into calf-deep water. "It was one of the hardest and most heart-wrenching steps I have ever taken," Wayne wrote later.

After being severely sand-blasted before reaching the shelter of the Octopus Resort, they were "greeted with generosity" by the resort staff. Neria was given a dress within moments of their arrival, as she'd arrived wearing only her soaking-wet underwear and a lifejacket.

In stark contrast to the incredible kindness showed by some of the locals, others looted most of the couple's possessions and boat gear before the shipwrecked sailors could mount a salvage effort. "When we flew out of Nadi three days after the storm, the sum total of our possessions fell well within the Air New Zealand weight allowance."

What's next for Wayne and Neria? Right now they're licking their wounds in New Zealand and reassessing their options. "There will be other boats," says Wayne, "but none like *Moonduster*. Like all wooden boats, she had character, but she also had soul."

(Read Wayne's complete, blow-by-blow account of this sad tale at [www.latitude38.com/features/moonduster.html](http://www.latitude38.com/features/moonduster.html)).

— *andy*

**fire up the bug light**

It takes a certain kind of person to sail alone to Hawaii. We don't like to generalize, but having been at the finish line of the Singlehanded TransPac a few times, we can do so in this case with some authority. And most of the racers would proudly agree. After all, it was a veteran of the race, Greg Morris, who characterized the contest as "a bug light for weirdos with boats."

In the '08 running of this 2,100-mile jaunt from San Francisco to Kauai, 22 "weirdos" sailed into Hanalei Bay — tired, perhaps a little thinner, but every single one wearing a big-ass grin.

The bug light is once again burning bright, with the 17th edition of the race scheduled to start on June 19. Race Co-Chair Bob Johnston says that, by the time this issue hits the streets, prospective racers will be able to sign up online at [www.sfbaysss.org](http://www.sfbaysss.org).

Though there were no official entries as we went to press, one sailor who insists he'll be at the starting line is Sausalito's Adam Correa. Correa started sailing just four years ago on a Pearson Ariel. A dedicated surfer and all-around water person, he took to the sport like, well, a fish to water. Over the past four years, Correa has 'traded

continued on outside column of next sightings page

## shtp — cont'd

up' several more times, culminating in a beautiful 26-ft International Folkboat that was featured on the cover of the January '09 issue. A self-proclaimed minimalist, Correa started prepping *Storm Petrel* for the Singlehanded TransPac, but the boat was in such great shape, little work was needed.



Everything on 'Blue Moon' is miniature, including this adorable gimballed cooker.

In March, Correa's wandering eye landed on a fascinating flush-deck speedster: the OL 33 *Tamara*. It was love at first sight. Designed in Denmark, the sleek racer/cruiser is well-respected in Europe, but relatively unknown on this side of the Pond. Her comparatively spacious interior began calling to Correa. "I went back and forth for a week," he recalls. "I loved the simplicity of *Storm Petrel* but I couldn't get my mind off *Tamara*. I finally bit the bullet and bought her."

Over the next eight months, Correa got *Tamara* race-ready, though that didn't take much. Then, just as he was installing the last of the

stanchions he bought to meet race requirements, he had an epiphany: *Tamara* wasn't the boat he really wanted. "She really was a sweet boat — fast, responsive, well-mannered" he said. "But she was a little too much boat for my taste. I realized that the feisty little Folkboat was the boat for me, so I started looking for another one."

Almost as soon as his search began, it ended when he found a slightly crusty model up the creek in San Rafael. "She needed a lot more work than either of my last two boats, but I think I can really make her right," he says.

One might be tempted to question Correa's dedication to sailing in this summer's race, what with all these boat changes. "Oh, I'm there," he growled. "There is absolutely no way I'll miss the start." For what it's worth, we don't doubt it. The transformation of *Blue Moon* has been nothing short of miraculous. A true testament to the lengths a 'weirdo' will go to to sail singlehanded to Hawaii.

— ladonna

## the great light debate of 2010

Imagine if Detroit came out with an automobile that was large, luxurious, comfortable, lasted forever and got 250 miles per gallon. Unfortunately, that's not going to happen anytime soon. Fortunately, the equivalent in 12-volt lighting for boats has already been perfected. Not all boat owners know about it because there's rarely the need to change boat lighting fixtures.

Oddly enough, the brilliant — sorry for the pun — development in boat lighting has resulted in a fight breaking out in the *Latitude* office between Editor LaDonna Bubak and the Publisher. Both claim their lights are superior.

**The Publisher:** We prefer LunaSea's cold cathode fluorescent lights (CCFL), and not just because they last five times — 30,000 hours — longer than compact fluorescent lights (CFLs) and traditional fluorescent lights. We all know how awful typical fluorescent lights are. They put out an annoying, gray-white light with an incomplete cast that makes even the most beautiful woman appear ghoulish. They also aren't very bright, have a tendency to flicker, and don't last all that long. CCFL lights, on the other hand, give off a steady, full,

continued on outside column of next sightings page

## latitude wants

Ask three sailors for their opinions and you'll likely end up with five different answers. That can be a frightening thought when you're toying with the idea of surveying your readers about what they like and . . . *gulp!* . . . don't like about your magazine. But we're brave souls here at *Latitude 38*, so we're forging ahead.

Sometime in mid-January (we're shooting for January 11, but cut us some slack

*'Blue Moon', which has a paint job in her near future, is undergoing a complete refit. Adam insists she'll be ready for the start of the Singlehanded TransPac on June 19.*





## your opinion

if we're late), we'll be posting a link on our homepage at [www.latitude38.com](http://www.latitude38.com) to an in-depth survey about the magazine and website. Respondents will have the option to be totally anonymous, but those who include their names and contact info will be entered in a random drawing for some hot *Latitude* gear. Keep an eye out in *Lectronic* for the official start date.

— *ladonna*

## lights — cont'd

milk-white light that isn't the least bit blinding.

Furthermore, our LunaSeas have nine brightness levels — just like your laptop. Indeed, the lighting technology comes from the laptop world where energy efficiency is so crucial. The importance of different lighting levels is not to be underestimated. For example, you want the light at the brightest setting when you're making dinner in the galley to make sure you don't cut off the end of your finger while slicing the tomatoes. But later, when you're trying to seduce your date into crewing for you to Easter Island, you want to dim the light to the lowest

continued on outside column of next sightings page



PHOTOS LATITUDE / LADONNA

# SIGHTINGS

## lights — cont'd

and most romantic level.

The typical LunaSea fluorescent panel has four tubes. You can buy the fixtures with four white tubes, or with two white and two vision-saving red tubes. And the CCFL red is straight out of Hades. In fact, we leave *Profligate's* red CCFL light on in the salon all night, confident that if thieves were looking to rob a boat, they'd pick one whose interior looked less hellish. But there's more. When the CCFL red is combined with a \$14 string of blue 110-volt LED lights from Target, the interior of *Profligate* takes on the look of an expensive Vegas lounge where drinks are served until dawn. In fact, once the sun sets, we've taken to referring to our cat as Club Velvet.

**LaDonna:** We love our Alpenglow 9-watt dual-power CFL white/  
continued on outside column of next sightings page

## caban circumnavigates

For two and a half years we've followed Polish stunner Natasza Caban single-hand her way around the world, and on December 2, the 32-year-old crossed her outbound track when she sailed into Honolulu. Caban left Honolulu in July '07, aboard her S&S 34 *Tanasza Polska Ustka* for what she'd hoped would be a two-year westabout circumnavigation. The Pacific hurricane season forced unscheduled stops in the Galapagos and Marquesas on her way back, but in spite of that, this slight-but-tougher-than-nails beauty

continued in middle column of next sightings page

IN CORNER NUMBER ONE (SPREAD): LATITUDE / RICHARD; IN CORNER NUMBER TWO (INSET): LATITUDE / LADONNA





AGNIESZKA CABAN

*Caban, solo circumnavigator.*

## lights — cont'd

LED red lights. Not only do the white CFL bulbs give off a brilliant — but not blinding — warm, flicker-free light, the units themselves are hand-built from your choice of teak, mahogany, oak or cherry frames, so they make a handsome addition to any salon. Our guests are often surprised to find our lights are fluorescent.

Yes, we admit the Publisher's CCFLs will last five times longer than our CFLs. But he's conveniently forgotten to mention that, according to each company's official spec sheet, our hand-built Alpenglows kick his LunaSea's plastic ass in the arena of energy efficiency.

Spec sheets can get confusing, but only three numbers really matter: current draw, lumen output and bulb life. According to the manufacturers, LunaSea's light draws 1.45 amps at 12 volts (its highest setting) while the Alpenglow draws .85 amp on High and just .4 amp on Low. So, even when it's drawing the most current, the Alpenglow light uses 42% less energy than the LunaSea. When on Low, it draws a whopping 72% less! And let's not even touch on the subject of his CCFL reds compared to our LED reds. That might get downright embarrassing.

Such a huge difference in energy usage might lead one to believe that, when switched to Low, the Alpenglow would be significantly dimmer than the LunaSea. Surprise! Referring once again to those pesky spec sheets, the LunaSea light puts out 184 lumens at 1.45 amps (High) while the Alpenglow generates 300 lumens . . . on Low! On High, the Alpenglow offers 600 lumens — more than three times as much output as the LunaSea.

We'll happily take the inconvenience — and very minor expense — of changing out the bulbs every few years if we can get numbers like those in such an attractive package.

Of course, we haven't compared the two models side by side, so it's impossible to say whose lights are really the best. Probably neither. In fact, there are probably a dozen other lighting companies who could prove their products are superior. So if our little tiff serves a purpose — other than to entertain — it's to show that, no matter which high-efficiency light you ultimately choose, you'll likely be rewarded with a quality product that's more efficient than you ever dreamed.

We just wish Detroit would catch up with the lighting industry.

— richard & ladonna



*Spread: Carol Baggerly and Glenn Twitchell bask in the glow of a red LunaSea CCFL in the galley of Club Velvet. Inset, inside the Alpenglow's handsome housing hides a lean, mean lighting machine.*

## sailor drowns in sight of safety

The final days of November saw some of the most ferocious weather of the year off the Northern California coast. On Friday, November 27 — the day after Thanksgiving — sustained coastal winds were clocked at 20 knots and above, with much higher gusts. Thanks to the residual influence of a massive low that descended on the Bay Area from the Gulf of Alaska, coastal swells measured up to 25 feet.

Not many boaters ventured offshore in those conditions, especially northbound. But Matthew Runte, 49, and his brother-in-law were evidently determined to bring Runte's 34-ft sloop *Sunyata* home to San Francisco Bay that day, after having enjoyed a Thanksgiving gathering in Santa Cruz. Sadly, that decision, and others which followed, led to Runte's death within sight of the Half Moon Bay's Pillar Point Harbor.

As Pillar Point Harbormaster Dan Temko notes, the first unfortunate decision the pair made was to not adjust their plans to the prevailing weather conditions. Temko was told by the unidentified crewman, that the pair left Santa Cruz before dawn, November 27, despite gale



JEFF BERMAN

*The wave-battered 'Sunyata' being towed in.*

continued on outside column of next sightings page

# SIGHTINGS

## drowning — cont'd

and hazardous sea warnings, and reached Pillar Point in the late afternoon. They had reportedly followed an 80-ft depth contour line north, which many mariners would consider to be dangerously close to shore in such conditions. Although the two men were apparently safely inside Pillar Point's outer breakwater shortly before sundown, they decided to press on to the north.

At roughly 4:30 p.m., with his crewman below, Runte — a longtime sailor and avid outdoorsman — piloted *Sunyata* out of the breakwater. But instead of continuing south around the green #3 channel buoy, he took a right — westward — which soon put the sloop into the perilous swells crashing over Half Moon Bay's notorious reef. *Sunyata* apparently suffered a violent knockdown which launched Runte overboard. The crewman fired off a flare that was seen in the twilight by people ashore, who quickly called 911 to report a boat in distress.

The call triggered a multi-agency response. Two 47-ft motor lifeboats were dispatched from Coast Guard Station Golden Gate (their closest base) plus a Dolphin helicopter from Air Station San Francisco. Pillar Point's own Search and Rescue boat also responded, quickly rescuing the crewman, and towing *Sunyata* to safety. Despite the best efforts of the SAR unit, the Guardsmen and local Fire and Sheriff's Department assets, at least an hour passed before Runte was finally located by the helo crew. When picked up by Pillar Point SAR, he was wearing his lifejacket, but was floating face down. His rescuers administered CPR, but, sadly, could not revive him.

Our sincere condolences go out to Runte's family and friends. We report on his tragic death here so that other coastal mariners may learn from the circumstances of his death. The obvious lessons for us all are to take wind and sea-state warnings seriously, and to be willing to alter your plans when conditions deteriorate.

— andy

## a mid-ocean commitment

Getting married is a very big deal for most people. So it's no wonder that most brides and grooms try to make their ceremonies as special as possible. As far as we know, though, Bruce Balan's November wedding to Alene Rice was completely unique. Why? Because it took place aboard their Cross 46 trimaran *Migration* inside Minerva Reef, an uninhabited ring of coral that lies in the middle of the South Pacific, 250 miles southwest of Tonga.

As Bruce explains, it's a beautiful place with "crystal-clear aquamarine waters" and an abundant coral reef that disappears below the surface at high tide — "a perfect place for a special occasion."

So, on November 7 he cleverly stuffed a note into an empty bottle, pitched it overboard and called Alene up on deck. "The plan didn't work out

quite as simply as I'd hoped," he recalls, "but eventually Alene did see the bottle and, after retrieving it in the dinghy, opened it to find a marriage proposal from me."

She joyfully answered, "Yes!" During the process of inviting the other crews anchored there to a reception aboard *Migration*, a licensed

continued on outside column of next sightings page

## caban

made excellent time.

After she'd battled her way to Cape Town with a broken autopilot and an acute infection in her foot, we expected no less drama from the rest of Caban's journey through the Caribbean and Pacific. Indeed, not only did her autopilot once again give up the ghost in the middle of the Atlantic, but she contracted a throbbing ear infection on her way to Panama, and yet another severe skin infection just days from Hawaii. (We're not sure what's up with this girl's immune system but couldn't someone have slipped some



COURTESY MIGRATION

**Bruce Balan and Alene Rice took their vows aboard their Cross tri 'Migration' inside Minerva Reef.**

## — cont'd

Neosporin into her med kit?)

During her journey, Caban also raised funds — through Poland's Against the Odds Foundation — to bring disabled kids to visit her in Cocos Keeling and St. Lucia. "It's a dream come true to do something good with my sailing," she said.

We'd like to congratulate Natasza on a job well done, and wish her the best in her future endeavors — which we hope will include a visit to the doctor! Catch up on her adventure through her blog at <http://blog.nataszacaban.com/en>.

— ladonna

## commitment — cont'd

captain suggested, "If you'd like to get married here, we can do it!" That was an offer too appealing to pass up. So, at midday on November 9, 19 guests from seven countries — including good friends Rebecca and Patrick Childress of the Rhode Island-based Valiant 40 *Brick House*, who'd just arrived that morning — came aboard *Migration* to witness Bruce and Alene taking the vows that they'd just finished writing a few hours earlier.

Continuing the uniqueness of the affair, after the ceremony everyone went snorkeling together outside the reef, where, as Bruce puts it, "the water is clear, the coral carpet is plush, and the edge of the coral wall plummets down to profound blueness."

We say, three cheers for Bruce and Alene! May their union be as strong as their thirst for adventure.

— andy



**Winter wonderland** — Chilly winter temps didn't stop these sailors from enjoying a day on the Bay. Clockwise from here: Sailing adventurer and dedicated environmentalist Michael Reppy's Grainger 43 trimaran 'Dolphin Spirit' made a splash on the Bay; 'Blue Moon' sculls her way out of a calm; there's nothing like light winter breezes to practice spinnaker sailing aboard 'Leglus'; these hardy sailors wouldn't let cool weather keep them from their boats; the merry crew of 'Little Wing' defies the winter chill; 'Li Hua' is going places.



ALL PHOTOS LATITUDE / ROB & LADONNA

# WARM DECEMBER SUN

When Arjan Bok of the San Francisco-based Lidgard 30 *Rotkat* got back to the The City after doing the Ha-Ha, the plumbing contractor figured it would be awhile before he would return to his cat in Mexico. "But it took just two days in chilly San Francisco to know that I had to get back to the warmth of Banderas Bay. So I grabbed my business partner Craig Libertore, and longtime crew Tom

Friel, and hopped on a plane to Puerto Vallarta. There, we rounded out the crew with Sally Martin of Albany, who is spending a year in Sayulita with her son."

The perfect opportunity for Bok — and other boat owners who love 'nothing serious racing' — to enjoy the warmth there was doing the Banderas Bay Blast, December 2-4. The annual event was sponsored by the Punta Mita Yacht & Surf Club, the Vallarta YC, and a host of others. Thanks to the ultra-casual Baja Ha-Ha-style ambience of the event that is proving so popular, Bok's cat was joined by 31 other boats.

Since everybody is a winner in the Blast, we might as well acknowledge the victors first:

*Southwind*, Islander 36, Jean Gregory, Oceanside. *Eupsychia*, Cal 36, David Addleman, Monterey. *Laniack*, Yorktown 35, John White, Puerto Vallarta. *Isis*, Allied Princess 36, Burke & Kacey Stan'ell. *Island Mistress*, Wellington 47, Jeff and Judy Wahl, Puerto Vallarta. *Charissa*, Liberty 461, Tom Jones, San Francisco. *Belfana*, Catalina 30, Randy Hough, Vallarta YC. *Escape Velocity*, S2 7.9, Rush Faville, Vallarta YC. *Interlude*, Morgan

**Free berthing! No wonder the beautiful Marina Riviera Nayarit was packed for the Blast.**



38, Don and Peggy Cox, Puerto Vallarta. *Imagine*, Catalina 42, Tom and Diane Miller, San Francisco. *Destiny*, Catalina 42, John and Gilly Foy, Punta Mita Y&S. *Tomatillo*, Jeanneau 43DS, Jim Casey, Punta Mita Y&S. *Raptor Dance*, Valiant 50, Bill Finkelstein and Mary Mack, Vallarta YC. *Maya*, LaFitte 44, Rick Meyerhoff, Sausalito. *Bright Star*, Jean-

neau 40, Dorr Anderson, Vallarta YC. *Coastal Passage*, Hunter 460, Terry and Michelle Willis, San Diego. *Synchrony*, Tartan 41, Juliet Di Giovanni, San Francisco. *Adios*, Columbia 43, Craig Shaw, Portland. *Tabu*, Farr 44, Rich and Sheri Crowe, Newport Beach. *Blue*, J/160, Ken and Cheryl Sears, Vallarta YC. *Sceptre*, J/130, Bob Musor, San Francisco. *Cap-*



**Tom Miller of San Francisco finds out there are few things as refreshing as a water balloon to the noggin late on a December afternoon at La Cruz.**

# THE BANDERAS BAY BLAST



**Left to right, top to bottom:** John and Gilly Foy's well-sailed Catalina 42 'Destiny' with the 'hearty' spinnaker. Sunset at Mita. The Blast crew at the Marina Riviera Nayarit's Sky Bar. Arjan Bok and his jolly 'Rotkat' crew. A crewman from the Vallarta-based 'Alarife' walks the hot line. Chuck, Mark and Shannon of 'Younger Girl'. Sheri Crowe did the driving on 'Tabu'. Ashley of 'Eleganz' pouring on the 'tard at the Punta Mita Yacht & Surf Club. David Addleman on one of his last sails aboard 'Eupsychia'. Symmetry in motion, with Capricorn Cat' and 'Sea Level' in a luffing bout. Stephanie driving 'Profligate'. Scott Case powers the F-P 40 'Twins' away from two Lagoons. Commodore Tammy initiates boyfriend Mike into the Punta Mita Yacht & Surf Club.

ricorn Cat, Hughes 45 cat, Wayne Hendryx, Punta Mita Y&S. Profligate, Surfin' 63 cat, Dona de Mallorca, Punta Mita Y&S. Beach Access, Lagoon 380, Glenn

Twitchell, Punta Mita Y&S. Younger Girl, Lagoon 380, Mark Sciarretta, San Diego. Twins, FP 44 cat, Scott Case, Ecuador. Sea Level, Schionning 49, Jim and Kent

Milski, Colorado. Eleganz, Lagoon 380, Medina Family, Colorado. RotKat, Lidgard 43 cat, Arjan Bok, San Francisco. Nina May, Catana 431, Jeff Parish. And

# WARM DECEMBER SUN

there were, no doubt, a few more that we missed.

The Blast's courses are short and sweet. The first race was about seven miles from either Nuevo Vallarta or Punta Mita to still-charming La Cruz. It was so uncharacteristically light that a lot of boats coming down from Punta Mita took DNFs. But who could complain with the Marina Riviera Nayarit providing free berths, the entertainment of the three-story water balloon drop from the Sky Bar, the yummy street tacos in town, music and dancing at Philo's Bar, and the warm weather?

Fluke Fest best describes the first half of the second race, which was back to Punta Mita. But the second half was a nice close reach to a beat up the jungle-covered, surf-streaked north shore of Banderas Bay. The wind topped out in the middle of the race at about 17 knots, but thanks to it being on the windward side of the bay, there was only the slightest chop. If you've not sailed upwind at hull speed in 15 knots of wind, and been plenty warm wearing only a pair of shorts, you don't know what living is. It was still early enough in the year that there were only a few whales on the course, so a minimum of dodging was required, and there were no collisions.

That night was the annual reopening of the Punta Mita Yacht & Surf Club at its luxurious two-story El Dorado facility at the water's edge. While the food was delicious, the drinks strong, and the bills small, the highlight of the evening was when Commodore Tammy Davis, dressed to slay the heart of every pirate, used the big carbon stand-up surfboard paddle to whack new members into the club.

***Cheryl Sears is all smiles, driving 'Blue' through the light air.***



"This hurts me more than it does you," she lied. As you might expect, membership in the exclusive club soared. New inductees had to to sail there, pay a lifetime membership of \$1, get a whack on the ass, and drink mango Kool-Aid.

The last day of the Blast was the historic Pirates for Pupils



Spinnaker Run for Charity to Nuevo Vallarta. After two days of slightly subpar Banderas Bay sailing conditions, the start of the P for P couldn't have looked more promising. Indeed, the boats rocketed away from the Punta Mita starting line at hull speed in 15 knots of wind on the beam with brilliant blue skies overhead. Unfortunately, halfway across the

bay, yet again, the good wind fizzled to nothing. Several boats, following the lead of local knowledge guru Mike Danielson on the J/160 *Blue*, rode the edge of the wind line all the way across the bay at a 90-degree angle to the finish line. It was lovely sailing in a good breeze and bright sunshine, but the VMG was less than 0, and those who followed the course were



# THE BANDERAS BAY BLAST



*Left to right, top to bottom: The entry 'Gaia' shows that green hulled boats were allowed this year. 'Cap Cat's' Carol had more than a ball. Ubiquitous Commodore Tammy looked great in search of thrills. Pirate Randy Hough made his classic Catalina 30 — seen in the next photo — really move. 'Tabu' has the inside track on 'Bright Star' and 'Blue'. 'Rotkat' battles light air and a big class at the start of the second race. During gaps in the breeze, Mike of 'Profligate' entertained everyone by levitating. Sheri Crowe, center, with the crew she and Rich picked up at Tenacatia Bay. Some of the crew at the beach of the spacious Yacht & Surf Club clubhouse. Jinger Yachechak takes a wet one for the fleet. Tammy points the way to the finish line.*

no closer than those who had steadfastly sailed one third of the distance on the rhumbline.

The crews who stuck it out the longest were John and Gilly Foy on *Destiny*, singlehander Bernard Slabeck

on *Simple Pleasures*, Jim Casey on *Tomatillo*, Rich and Sheri Crowe on *Tabu*, and perhaps one or two others. To our knowledge, nobody quite finished, even

# WARM DECEMBER SUN

with the extended time. But that didn't diminish anyone's fun.

Paradise Village Marina Harbormaster Dick Markie was the hero of the evening, coming through with free berths for all participants. "We're here to help people have a great time," he said. And the on-site Vallarta YC opened its doors — and pool — to the Blasters.



**Looking sleek and sexy, Jim and Kent Miiski's self-built Schionning 49 'Sea Level' was one of the fleet's speedier cats.**

will grow in the future, as the super-casual format has been embraced by just about everyone. Fun with friends, not beating someone, is the goal.

**I**f you've got friends who will be doing the Blast with their boat next year, we suggest you try

to hook up with them for the entire Banderas Bay Blast week. That way you can spend the first three days enjoying all the charms of the area. Street tacos at night in Sayulita, surfing at Punta Mita, spending a night at Yelapa, diving at the Tres Marietas Islands, watching the whales, and then doing the Blast. The day after the Blast you can roam around romantic Puerto Vallarta, then finish it off with the crowds at the Vallarta YC's Chili Cook-off — their biggest fundraiser of the year. So mark those calendars for Nov. 28-Dec. 4 of next year. We're sure Arjan will be there.

**F**un is fun, but one of the main reasons for the Blast is to raise money for the educational and environmental needs of the north coast of Banderas Bay. Nearly \$3,000 was raised. One thousand of it was donated in the name of the '09 Ha-Ha

fleet, over \$700 was raised by Mike Danielson's Luchee Libre, which is a deal where skippers bet they can beat

other boats, with the loser paying the money to charity. Other sources of revenue were Club memberships, the new Y&S Club shirts, and several hundred dollars from the owner of a wonderful schooner in San Diego. Thanks to Tea Lady Ronnie — who oversees the distribution of the donations in the form of needed supplies rather than cash — the money goes as far as it can. It's expected that the event and the donations

— **latitude**



*Tim and Jillian Silva, Captain and First Mate, m/y Tenacity*

"Shipping with DYT gives us peace of mind that the boat will arrive on time at our destination, mechanically intact, and with a fresh crew, so that the owners can start enjoying their boat without delays or disruption of their busy schedule.

Dockwise has held a special meaning for us since we met crossing the Atlantic on the Super Servant 4. We hope to continue exploring new places like the South Pacific, and Alaska, and DYT will be our first and only choice for transport."

**DOCKWISE YACHT TRANSPORT**  
WORLD CLASS YACHT LOGISTICS

**Yacht at Rest, Mind at Ease**  
[WWW.YACHT-TRANSPORT.COM](http://WWW.YACHT-TRANSPORT.COM) • 1-888-SHIP-DYT

Voted the...  
Best Marina in Mexico!



# Paradise Village™ MARINA

*Treasure of the Mexican Gold Coast*



Share with us our Successful combination:  
Special Price | Service | Security | Location

## *Services:*

- Electrical service, 110/30 amps
- 220/50 amps and 3 phase 100 amps
- Crystal Clear Potable Water
- Cable TV
- Garbage Collection
- Pump - out Station
- Fire Fighting Boat Protection
- 24 Hrs. Security
- Computerized gate access

## *Additional Services:*

- Vallarta Yacht Club
- Special area for marina guests
- Restrooms
- Lockers
- Showers
- Pool and jacuzzi
- Free access to all the facilities of our 5 star hotel
- White sand beach
- Dive tank refilled
- Propane refill
- Launch ramp



CONTACT US: [marina@paradisevillagegroup.com](mailto:marina@paradisevillagegroup.com)  
Phone & fax from U.S. 011-52-322-22-66728  
[www.paradisevillage.com](http://www.paradisevillage.com)



# A TRIBUTE —

With a little bit of reading, you can find the various marks of distinction in Roy E. Disney's productive life. You can catalog his sailing records and his 15

TransPacs. You can note his unparalleled philanthropic record. You can note his business accomplishments. But between those markers lies the nuance that made him what he was.

He was the type of guy who could pop up out of the cabin with a bowl of instant soup and remark, "Wow, this is really good."

Then turn the bowl to look at the label and declaring, "I just bought this company."

He was a guy who could fly his entire crew — and, whenever they were able, his crews' spouses and offspring — to regattas around the world in a Boeing 737 business jet nicknamed 'Air Shamrock.'

He was also the type of guy who, when he had to return home unexpectedly — while the rest of the crew remained in New Zealand building his MaxZ 86 *Pyewacket 4* — would fly commercial, and leave the jet for them.

He constantly pushed the envelope with his line of *Pyewackets* which included a N/M 68, SC 70 (later turboed) an R/P 73 and finally the 86 (also later turboed). But he was an unflinching champion of the participation in his favorite race — the TransPac — by people from all walks of life.

"At the press conference for the 2005 TransPac, Roy was at the front table, and all press attention was on him," recalls Scott Self, who, with Nigel Brown, won Division V and the doublehanded title on a Hobie 33 that year. "He noticed us in the back of the room and insisted that we come up to the front table and sit beside him. The press was unimpressed with us. But Roy was impressed and insisted on sharing the limelight. He was inter-

ested in our experience, and pleased that a couple regular sailors from Texas competed. He wanted to encourage regular folks to race the TransPac. He was one of our inspirations to do the race in the first place."

To hear it from people who knew him well, and even those who didn't, Roy E. Disney was the type of guy who was larger than life, but never aloof.

Since he passed away from stomach

*"He was a happy man, gracious and thoughtful with everything he did."*

cancer on December 16, Disney's sailing and business accomplishments have been retold countless times. We could devote eight pages to telling his life story and still not get close to showing the complete picture of who he was. So rather than re-hash those details, we thought we'd let some of his long-time crew, many of whom sailed with him for at least of 15 years, describe in their own words what he was like to sail with and know:

**Rick Brent:** "He loved to have a good time and loved to be with his boys, and in turn, because of his great attitude, we loved to sail with him and each other. I was brought onboard as a trimmer, but then had to fill in on the bow, and ended up staying there. Everyone used to give

me grief about calling tactics from the bow. When we'd go to Hawaii, he would say, 'We can't go without Rick. . . How will we get there if we don't have Rick to tell us where to go?'"

**Gregg Hedrick:** "In the '95 Cabo Race, we were dueling all the way down to Cabo Falso with *Cheval*. The two boats were just attached. We were short-jibing into the breakers off Cabo Falso, and Gary Weisman and I decided we needed some fresh fish, so I tossed in a lure. On a jibe in, we were approaching the breakers and we hooked a mahi mahi. Roy's saying, 'We've gotta jibe.' Weisman said, 'just a second Roy, just a second, we've gotta get this fish.' So we pulled this thing into the cockpit, threw it at Roy's feet and jibed the boat with this mahi mahi flopping around at his feet. He said, 'what are you guys thinking?' We completed the jibe and I ran back there to start wailing on this fish with a winch handle. I look up and there's blood and fish guts splattered all over

**Right:** The 'Pyewacket' crew blasting down the Molokai Channel. **Below:** Finally, the record; after seven attempts, Disney finally set the monohull race record in the '99 TransPac, bettering the time set by his son Roy Pat in '97.



**Roy Disney leaves a vibrant legacy to the West Coast sailing community.**



SHARON GREEN / WWW.ULTIMATESAILING.COM



LATITUDE ARCHIVES

# TO ROY DISNEY

Roy's legs. I just looked up at him and told him, 'Roy, a lot of owners never get to see this.' A lot of owners would have gone crazy over something like that, but Roy just kept his cool and kept steering the boat even with fish guts flying everywhere."

**Ben Mitchell:** "When he first got the Boeing jet, he couldn't bring it into Cali-

fornia for tax reasons or something, so we flew in his old plane — which was a really nice 10-seater — to Vegas to board the Boeing jet. We boarded the jet and he sat down in one of the captain's chairs with a huge grin on his face, and said, 'How do you guys like me now?'"

**Stan Honey:** "Joining the *Pyewacket* crew felt more like being adopted into a

family than like joining a race crew. Roy was astonishingly committed to his crew, and the crew similarly became very committed to Roy. Even though I navigated with Roy for 15 years, I was still one of the 'new guys.' Most of the guys on the crew had sailed with him for far longer. Roy loved sailing to a surprising degree. Whenever we took *Pyewacket* out on a weekday afternoon to calibrate instruments or check a sail, if Roy wasn't tied up at work, Roy would come with us and spend all afternoon on the helm. It was

an honor to be a part of Roy's sailing family."

**Rick Brent:** "People would ask me about Roy, and I'd say, 'There's a long list to get on the boat.' Gary Weisman used to say, 'Even the President is waiting in line.'"

**Robbie Haines:** "People would call me when they wanted to go sailing with us, and it was really frustrating, because I could never take anyone. No one would ever leave."

**The 'Morning Light' sailors got the chance of a lifetime thanks to Roy Disney.**

**Scott Eason:** "I had done some sailing on *Pyewacket* as the local knowledge guy for the Big Boat Series, and I remember asking everyone at one point, 'How do I go offshore with you guys?' They told me, 'Well, you have to get on the shortlist . . . and you're not even on the list.'"

**Doug Rastello:** "He was such a special guy. I spent at least four months a year with him for like ten years. I learned so many things from him about being such a first class individual . . . how to treat people."

**Rick Brent:** "The 'round the world guys would always ask me what's he like? It's funny, he almost just personified the Disney ethos, in that he was just a happy man — gracious and thoughtful with everything he did. Make no mistake about it, he was competitive. He did like to win. But if he didn't win . . . I never saw Roy have a meltdown in all those years, with millions of dollars on the line, when things would break or blow up."



LATITUDE ARCHIVES

# ROY DISNEY

Obviously he wasn't happy about it, but he didn't start yelling or throw a temper tantrum."

**Roy Pat Disney** (Roy's son): "My dad was a collaborator. He wanted to get the best out of everybody. He wasn't an autocrat that way. He felt that what was good for everybody was good for the boat. He always felt that the TransPac is all about that repeatable moment. There's that magic moment you get when you're out there, and you keep coming back to try to experience that."



*Roy Disney was as comfortable in a crowd of sailors as he was in a corporate boardroom.*

No appraisal of Roy Disney would be complete without referencing his considerable philanthropic contributions, not the least of which were the sizable annual contributions he made to the California International Sailing Association (CISA), which in turn distributed

grants to everything from junior Olympic aspirants to community sailing programs for at-risk, inner-city youth. He also supported the TransPac and helped to establish its museum. He "Clock Trophy" that resides in it, which he gifted to the

race for the holder of the monohull race record. *Morning Light*, the film he produced about the '07 TransPac, has already seen one of its cast members shortlisted for the Rolex U.S. Sailing Yachtswoman of the Year award.

His generosity and loyalty also touched the people who sailed with him.

"The group of sailors he was involved with gave him 110 percent, 100 percent of the time and it was because of who he was," Rastello said. "We sailed for him, for sure, absolutely."

Unfortunately, we were forced to leave many humorous and telling tales of Roy E. Disney on the pasteboard when putting this tribute together because we simply didn't have room for them all. But we wanted a chance to at least say, "Thank you Roy, for everything you've done for Sailing."

— *latitude / rob*

**DOWNTIME?**  
**PERFECT TIME FOR MAINTENANCE,  
REPAIR AND UPGRADES**

This winter, we can clean, maintain and repair your deck hardware – or upgrade them. There's no better time than **NOW!** Full rig inspections available.

**NEW Harken radial winches, electric furling, and more!**

**EASOM**  
Racing and Rigging

**Easom Racing and Rigging**  
1150 Brickyard Cove Rd. Suite B1  
Point Richmond, CA 94801  
**(510) 232-SAIL (7245)**  
[www.easomrigging.com](http://www.easomrigging.com)

# SCHOONMAKER POINT MARINA

• IN SAUSALITO •



Call the Marina Office  
for more information

**415•331•5550**

**FAX 415•331•8523**

or check our web site at  
[www.schoonmakermarina.com](http://www.schoonmakermarina.com)

85 LIBERTY SHIP WAY, #205  
SAUSALITO, CA 94965



## 160 Berth Marina in one of the most beautiful spots on the Bay

- Visitor berths • Guest moorage able to handle yachts up to 200 ft.
- Dry storage • Waterfront Offices • Three-ton Hoist • Windsurfing
- Deli • Beach • Rowing • Kayaking • Yacht clubs always welcome

## THE RELIABILITY'S BUILT IN!



**HONDA  
MARINE**  
PROVEN



We offer complete service on all Honda outboards and inflatable boats and take pride in providing the kind of customer satisfaction that you expect from Honda.



**The Dinghy Doctor**  
1271 Scott Street  
San Diego, CA 92106  
Tues-Sat, 9am-5pm  
**(619) 804-6921**

[www.thedinghydoctor.com](http://www.thedinghydoctor.com)

2 blocks  
off Shelter  
Island

AB, Achilles, Zodiac, Walker Bay,  
repair kits, engine parts, and  
everything you will need in Mexico.

Always wear a personal flotation device while boating and read your owner's manual.

### BF20

- Unsurpassed fuel economy
- Shallow water drive
- Largest displacement in its class (21.4 CI)
- Hi Output alternator (12 amps)

## McDERMOTT COSTA

insurance brokers - est. 1938

### Commercial Operations

- COMMERCIAL POLICIES  
Marinas, Yards,  
Yacht Clubs,  
Brokers,  
Shipwrights

### Pleasure Yachting

- YACHT & BOAT POLICIES  
Offshore, Coastal,  
Inland and  
Liveaboards



Lic. #OB21939

**Bill Fowler**

McDERMOTT COSTA INSURANCE  
**(925) 606-6606** Fax (510) 357-3230  
[bfowler@mcdermottcosta.com](mailto:bfowler@mcdermottcosta.com)



# 2009 — THE YEAR



COURTESY CONNSEA

After a nine-year circumnavigation, Clark Beek now calls the Bay Area home.



MIKE HARKER

In the year following his 11-month solo circumnavigation on 'Wanderlust 3', Mike Harker has had no trouble finding able-bodied crew.



MARGARET REID

Zihua Sailfest helps raise funds to send indigenous kids — like these hams — to school.



JOHN SHUPING

Your vibes get even worse when Bob tags — and vandals loot — your boat after your kid runs it aground on New Year's Eve.



PATRICK BURNS / STILL N MOTION

The 'Get Out The Boat' campaign motivated sailors to take their friends out for daysails.

The 60-ft French foiler 'l'Hydroptère' hit 61 knots — a tick over 70 mph — before pitchpoling near Marseilles.



Some years are better than others, and 2009 turned out to be one of the others. With the country deep in a recession, many sailors were too anxious to go sailing on their own, so we did our best to bring the sailing to them. Here's a quick recap of the biggest news from 2009. The first issue of the year — **January** — was a real blast, with tales of epic proportions: Thomas Coville beat his own solo record by averaging 26.19 knots on his 105-ft Irens/Cabaret-designed *Sodeb'O*, tearing off 628.5 miles in 24 hours; Clark Beek sailed 60,000 miles to complete his nine-year circumnavigation, and came away with some rip-roaring stories; and of course the Banderas Bay Blast rounded out the festivities with water balloon drops, carbon fiber paddlings and some seriously kick-ass sailing. We were saddened to report on the December passing of well-loved Bay Area sailor Mik Beatie, who was a stalwart supporter of the sailing scene and all-around great guy. **February** was the month for mayhem. First we reported on the unbelievable speed Alain Thébault and his team hit aboard the 60-ft foiler *l'Hydroptère*: 61 knots! Of course the boat tripped over herself and pitched, sending the crew flying, but no one was hurt. Then we related the amazing rescue by Vendée Globe racer Vincent Riou of competitor Jean Le Cam when the latter's IMOCA 60 *VM Matériaux* capsized in the Southern Ocean. The stuff of legends! Up next was the exciting recovery of the three crew aboard the Aussie cruising boat *Timella*. Fellow cruisers Maurice and Sophie Conti on *Océaly*s managed to pluck the trio from Fijian waters after their boat broke up on a reef. We capped the issue off with some of the wackiest stories Bay Area harbor masters were willing to share.





LATITUDE / NICK

A 10-ft tiger shark was taken at Corssol Beach in St. Barth, prompting swimmers to check the water carefully before diving in for a swim.



LATITUDE / ROB

Brad Copper's crew on 'TNT' takes a snootfull on their way to win PHRF A in the Big Daddy Regatta.



ROXY / VENDEE GLOBE

While Michel Desjoyeaux won the Vendée Globe, newcomer Sam Davies won the world's attention.



GUILAIN GRENIER



GAR DUKE

Nicole Duke swims with the fishes in the Solomons.



MARINE CHILLENNE

When Jean Le Cam's 'VM Matériaux' turned turtle west of Cape Horn, fellow Vendée Globe racer Vincent Riou on 'PRB' came to the rescue.

If the previous month was full of drama, **March** was a time for celebrations. Karen Thorndike, the first American woman to solo circumnavigate via the five great capes, was honored for her 1998 accomplishment in a special Smithsonian exhibit in Washington D.C. Closer to home, 345 boats bumped their way around a breezeless course in the Three Bridge Fiasco, while Michel Desjoyeaux waved his flares as he crossed the line to win the Vendée Globe. Later in the issue, we featured a large group of Californians who rang in the New Year Caribbean-style and a group of cruisers who partied with a purpose at Zihua Sailfest. Nearly \$45,000 was raised to help send poor indigenous kids to school! Great news on all fronts in the **April** issue. That's where we learned about David de Rothschild's brainchild, *Plastiki* — a 72-ft ketch-rigged cat that will ply the ocean's waters using old soda bottles for flotation and will hopefully get people to change the way they think about trash. Not only did we explore how to get your kids involved in sailing, but we also featured the Winship family, who'd raised their two kids aboard while cruising the world. And for those cruising toward French Polynesia, we announced that we'd brokered bond exemptions for every single Puddle Jumper — then went on to profile the Class of '09. Back home, we invited readers to a special presentation by legendary sailor John Guzwell who was celebrating the 50th anniversary of his record-breaking circumnavigation. Those in attendance — including a number of sailing luminaries who count Guzwell as their hero — said it was an event they won't soon forget. Finally, we recapped the on- and off-the-water antics in Richmond YC's Big Daddy Regatta, which drew 99 boats.

# 2009 — THE YEAR



ERIC SIMONSON / H2OSHOTS.COM

The 19th annual Delta Ditch Run saw its biggest fleet ever with 152 starters. They were rewarded with solid, if anything but screaming, breezes.



LATITUDE / ROB

Boys will be boys, and these 'Criminals' really knew how to get into 'Mischief' at the TransPac finish line.



LATITUDE / ANDY

The 270-ft Mexican Navy tall ship 'Cauahuemoc' dropped in on a goodwill and cadet training mission.



JAY HICKMAN

The first-ever Delta Doo Dah was a doozy!

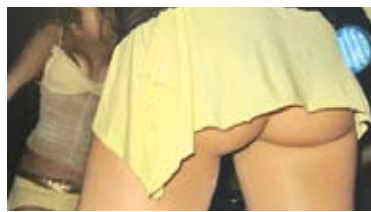

ANDREW VIK

Wherever he sails, Andrew Vik seems inexplicably drawn to the clubbing scene.



COURTESY TAIWAN COAST GUARD

A 192-ft tanker rammed the engineless 'Princess Tai Ping', a replica of a 15th-Century Chinese junk, then fled. Skipper Nelson Liu suffered a minor head injury.



LATITUDE / JR

**May** was a mix of tragedy and happy endings. A Somali pirate attack on an American container ship ended with the daring rescue of Captain Richard Phillips when Navy SEAL snipers shot his captors, but an attack on the French cruising boat *Tanit* a few days later ended in tragedy for the captive family when the skipper/husband was killed in a bungled rescue attempt. And while 26-year-old Aussie Sarah Andrews survived the grounding of her boat *Gabrielle* on a Mexican beach, the boat didn't. Later, we recounted the riveting tale of *Heat Wave*, the J/80 that capsized on the way back from the Doublehanded Farallones, and the amazing rescue of her crew in challenging nighttime conditions. Thankfully, there was no tragedy during the Banderas Bay Regatta or the Sea of Cortez Sailing Week — but we're sure there were plenty of happy endings! **We** were sad to report in the **June** issue of the loss of the lovely 54-ft junk *Princess Tai Ping*, a replica of a Ming Dynasty warship that had sailed to the West Coast from Hong Kong to test the theory that Chinese vessels may have travelled to North America before Columbus. *Tai Ping* was just 40 miles from home when a commercial ship sheared the boat in half, leaving her crew for dead. Thankfully, they only sustained minor injuries. We spoke with son-of-a-son-of-a-sailor Peter Carr, 70, about growing up with saltwater in his veins and his preference for cruising aboard folding trimarans. Of course, the annual Master Mariners Regatta made for great photo spreads, as it always does, even when the winds don't cooperate. Later, we welcomed several new boat owners to the fold, sharing their stories and dreams, and hopefully inspiring the rest of us to 'get out the boat'!



LATITUDE / LADONNA

*Nick Jaffe stopped by the Bay on his way to Australia via Hawaii.*



JEFF HARTJOY

*Jeff Hartjoy realized his dream to singlehand around Cape Horn aboard his Baba 40 'Sailors Run'.*



PETER LYONS / WWW.LYONSIMAGING.COM

*Skipper Dave Wilhite dove into the turtled 'Heat Wave' to recover a flashlight and VHF. Crew Dave Servais says that action saved their lives.*



LATITUDE / ANDY

*The highlight of the Tahiti-Moorea Sailing Rendezvous is the six-person outrigger canoe race.*

*The inaugural Media Cup was a rousing success. At least none of the 'guest celebrities' fed the fish!*



RICH ROBERTS

*Zac Sunderland solo circumnavigated into the record books . . . but for how long?*



LATITUDE / JR

*Old boats rule — at least during the annual Master Mariners Regatta.*



The **July** issue was packed full of big fun in the sun. The Delta Ditch Run got the party started with the biggest fleet in its 19-year history. The first-ever Media Cup kept the ball rolling in McCovey Cove during a Giants-A's game, complete with views of the 'competing' boats — crewed by local media personalities — flashing up on the JumboTron. Summer Sailstice, a global (well, northern hemisphere, anyway) celebration of sailing on the longest sailing days of the year, rounded out things locally with a massive raft-up in Clipper Cove and a killer party on Treasure Island. Farther afield, Puddle Jumpers were welcomed to their destination in true Polynesian style at the Tahiti-Moorea Sailing Rendezvous. Aussie singlehander Nick Jaffe waved goodbye to new friends as he sailed out the Gate on the next leg of his journey from England to Brisbane, while Santa Rosa's Jerry Morgan arrived back home, healthy and upbeat, after his Trintell 53 *Sumatra II* sank near Oz. **August** was a big month, with sea tales from Puddle Jumpers, 11-month circumnavigators Stephen Mann and Kathleen Torres, and party-boy Andrew Vik, whose enticing shots of the clubbing scene in the Adriatic drew ire and envy. At 17, Marina del Rey-native Zac Sunderland officially became the youngest person to solo circumnavigate, but Brit Mike Perham was hot on his heels. Competition really heated up in the 45th annual TransPac, with *Alfa Romeo* obliterating the old elapsed time record, *Pegasus 50* smashing the doublehanded record, and *Criminal Mischief* ripping the barn door off its hinges. We wrapped things up with a recap of *Latitude 38's* insanely fun inaugural Delta Doo Dah, a cruise from the Bay to the Delta. Now that's a tradition we intend to continue!

# 2009 — THE YEAR



SEAN TREW / WWW.PACIFICFOG.NET

**Damned if you do** — Racers in the 2nd annual Double Damned Race crashed and burned their way up the Gorge.



COURTESY CLIPPER VENTURES PLC

**The Clipper Round the World Race is no piece of cake**, as the crew of 'Hull & Humber' can tell you after they were t-boned by 'Cork'.



CHRIS DELLER

**The Samoan tsunami totaled a number of boats**, including 'Biscayne Bay', and took the life of Dan Olszewski, 69.



LIZ CLARK

**Liz weathered an engine room mishap** — and criticism for requesting donations — and is still surfin'.

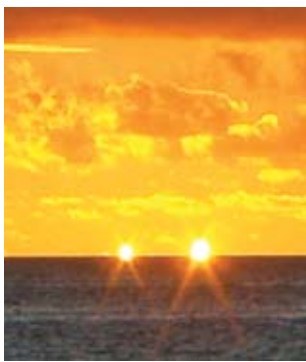

COURTESY DAYDREAM

**The lucky crew of 'Daydream' caught this spectacular sunset** which coincided with an eclipse.



LATITUDE / ANDY

**Philippe Kahn's Melges 32 'Pegasus' may have pulverized the Bay**, but 'Rougarou' finished in the top spot for that class.



**Leg One of the 16th annual Baja Ha-Ha was a rough ride**, prompting a 'time out' in San Quintin.

**September** was a month free from disaster, though there were a few close calls. One of our most followed stories was that of Bismarck Dinius, the hapless helmsman of a sailboat that was demolished by a speedboat driven by a Lake County Deputy Sheriff. Lynn Thornton was killed in the accident and Bismarck was charged with her death! We celebrated his acquittal and recapped the entire sordid affair. Mike Perham snatched the 'youngest around' record from Zac Sunderland, who'd held the title for a little over a month. We then travelled to the Columbia River Gorge to cover — and sail in — the second Double Damned Race, an upriver, downwind screamer from Cascade Locks to The Dalles. Another screamer was the unofficial duel between *Groupama 3* and *Banque Populaire*, each setting out on its own record attempt. The two monster tris pushed each other to break several records — including 900-mile days! We also met Tony Bigras and his tiny cat *Miss Cindy*, and talked with cruisers who make a living working from their boats. In **October**, we covered the 45th anniversary of the Rolex Big Boat Series, which also acted as the US IRC Nationals. The event also coincided with the 20th anniversary of the passing of legendary Bay sailor Tom Blackaller, so everyone brought their A game. From ultra-sophisticated carbon fiber sleds, we moved on to the beautifully refit *Eros*, a 70-year-old, 103-ft staysail schooner that would later sail to Mexico in the Ha-Ha. In between the two extremes was Jean Socrates' new *Nereida*, on which she set off for her solo circumnavigation. We discussed the pros and cons of three would-be circumnavigators: three teenage girls vying for a record. We wrapped things up with a review of the damage wrought by Mexican hurricane *Jimena*.

TONY BIGRAS



**Tony Bigras' 'Miss Cindy' rides atop his car between cruises.**

JULIEN GIRADOT / DPPI / TOTALLYMONEY.COM



**Mike Perham scudded into port about a month after two-month-old Zac, earning the title of Youngest Solo Circumnavigator.**

HAROLD LABONTE / WWW.LAKEONEWS.COM



**Emotions ran high all over the globe the day Bismarck Dinius was acquitted of manslaughter.**

COURTESY GEMINI



**'Jimena' left boating interests largely spared, but hardly unscathed.**

SHARON GREEN / WWW.ULTIMATESAILING.COM



**The crew of 'J World' had to ride out rough seas before being rescued.**



**In November**, we found out how, after finishing the '05 Ha-Ha, Damien McCullough and Deborah Ream took their Celestial 50 'Ticket To Ride' and ended up in St. Barth. Cruisers in Samoa mourned the death of one of their own after a tsunami wreaked widespread destruction in the islands. Several firsthand accounts of that day — and the subsequent clean-up efforts — really brought home how connected cruisers are to the communities they visit. In the wake of a particularly long-lasting Mexican hurricane season, we put together a year-by-year analysis of hurricanes in Mexico. We bid farewell to iconic yacht designer Bill Crealock, who passed away at the age of 89, and wished fair winds to 16-year-old would-be solo circumnavigator Jessica Watson as she set out on her quest to become the youngest around. **The year ended with a bang, and in December** we shared all the action from the 'Sweet Sixteen' Baja Ha-Ha. Entries topped 193 — the most ever! — before the start, with 163 crossing the line in San Diego. With more than 600 sailors along for the ride, the stories came in fast and furious, especially during the first leg when the wind and seas built enough to warrant the Poobah's calling a 'time out'. During that leg, the J/120 *J World* hit a whale, tearing a massive hole in the bottom of the boat. Skipper Eugenie Russell successfully ushered her crew of four into a liferaft as *J World* sank beneath their feet — they were rescued a few hours later by the Coasties. Finally, legendary sailor Eric Forsyth, who's sailed more than 240,000 miles on his Westsail 42 *Fiona*, stopped in after transiting the Northwest Passage. Of course there was so much more, so if you missed any of these stories, you can download entire issues from [www.latitude38.com](http://www.latitude38.com).

# ADVENTURE AWAITS —

**F**rench Polynesia: the tropical paradise every cruiser dreams of, and longs for. Or is it just an over-hyped, over-crowded, over-priced destination that will leave you looking for something



ALL PHOTOS ALENE D. RICE & BRUCE BALAN

**Traditions run deep in French Polynesia. Both men and women wear tattoos proudly. Aboard 'Migration', a new friend, Pautu, plays his uke.**

else, a real paradise?

Our year in French Polynesia is winding down as we sit at anchor in Bora Bora waiting out the *miramu* — reinforced SE tradewinds caused by a big high passing to the south. We'll visit one last island, Mopelia, 100 miles to the west, before our final *au revoir* as we head to the Cooks, Niue, Tonga, and New Zealand.

We're hunkered down aboard our Cross 46 tri *Migration*, as 40-knot gusts tear over and around the island's hills, and the occasional rain squall makes us jump to close the hatches. This downtime gives us a chance to look back on our year here and, we hope, come up with a few useful tips for those planning on crossing the big blue puddle.

## Don't Miss . . .

French Polynesia consists of more than 118 islands and atolls. You could spend years cruising here. Unfortunately, unless you arrange for a long-stay visa before leaving the United States, Americans are only allowed three months. A long-stay visa is something we highly recommend, but since most people don't go that route, we'll assume you only have three months. What shouldn't you miss?

1) *Anaho Bay, Nuku Hiva, Marquesas* — Unless you choose a southern route via Easter Island or the Gambiers, you'll probably arrive in French Polynesia in the Marquesas. You, and hundreds of other boats. Sure, it's great to visit with everyone, compare stories of the crossing, and buy some fresh veggies, but get out of town — be it Atuona on Hiva Oa, or Taiohae on Nuku Hiva — as soon as you can. Experience some of the lesser-visited anchorages. It's surprising how many you can find within a short sail of bays chock-a-block with boats.

Baie d'Anaho, on the north side of Nuku Hiva is our favorite. Soaring cliffs and sculpted peaks, fine protection from the trades, a population of only 10 to 20 friendly Marquesans, and the only coral reef in the Marquesas make it a hard place to leave. Manta rays and turtles swim through the bay. The water clarity isn't great but the quality of the coral makes it worth a snorkel every day. The hike along the "mango trail" to neighboring Hatiheu provides fantastic views, and all the mangoes you can carry. Yes, there are mosquitoes and no-see-ums, but that just comes with the territory. Remember to go slow as you approach the shore — the reef lining the beach pops up sooner than you think it should. Even with plenty of warning you'll see boats make speedy U-turns as they suss out the anchorage.

2) *Tumakohua Pass, Fakarava, Tuamotus* — We met a small French boat that spent four months diving dozens of passes in the Tuamotus. Their favorite, and ours, is Tumakohua: Fakarava's south pass. If you have dive gear, you're good to go. If you can't get friends from another boat to follow your bubbles in the dink, tie a 100-foot line to it and tow it along. Wait for the incoming tide when the wind isn't too strong. Start outside the pass and stay a bit to the right as you drift over the amazing coral carpet. Follow the bottom to about 70 feet and remember to keep your cool — and your eyes in their sockets — when you find the two hundred schooling grey sharks.

If you don't have your own gear, you can dive with one of the two outfits that work out of the *pensions* on the *motus* (islets) near the anchorage. If you don't dive, snorkel the pass. You'll still see eagle rays, sharks, and thousands of fish. You'll want a wetsuit because when you finish, you'll head right back out to do it again.

3) *A Week (or Two) Alone in the Tuamotus* — Fakarava is a popular atoll;

great for diving, but not for being alone. There is simply nothing that compares with spending time by yourself anchored in aquamarine waters off of a palm-lined white sand beach. Choose a smaller or less-populated atoll: Katiu, Kauchi, and Tahanea are all quite nice.

Wherever the wind is coming from, that's where you want to head. That usually means the east or southeast. Tacking through the lagoon usually makes for great sailing with steady winds and flat water. Just go in good light and keep a constant and sharp eye out for *karenas* — the large coral heads that dot the insides of the lagoons. They're easy to see as long as the sun is overhead or behind you. Find a *motu* that looks inviting — *motus* are islets that line most



# A FRENCH POLYNESIAN PRIMER

reefs. Then search for a sandy spot as free from coral heads as possible, and drop the hook. Spend your week swim-

*Tacking through the lagoon usually makes for great sailing with steady winds and flat water.*

ming, snorkeling, spearfishing, collecting shells, exploring the outer reef, cooking the fish you catch on a fire on the beach, and getting rid of all your tan lines.

4) *Coral Garden, Ilot Tautau, Taha'a, Society Islands* — Some of the best snor-

keling you'll find outside of the Tuamotus is at Taha'a. You won't be alone as this is charter boat heaven, but never mind. Hundreds of species of tropical fish, gorgeous coral, only 3 to 5 feet of water, and the peaks of Bora Bora rising on the horizon. Go on the end of the incoming tide for the clearest water and the extra foot of depth.

5) *Get to Know the Polynesians* — Yep, it can be tough with the language. But you had all those weeks on the crossing to study your French tapes, right? Learn a few words of Marquesan or Tahitian. Be friendly. Smile. Shake hands. Kiss cheeks (right first, then left). Share what you have. Invite new acquaintances aboard. Take them for a sail. Ask to go fishing with your new friends. If you are

around during the *Heiva* celebrations in the middle of July, plan on being in a small village for some great dancing, food, and camaraderie.



**Bruce, about to enjoy a free lunch. If you could live on mangoes and bananas, you'd never starve in the Society islands or Marquesas.**

## Don't Forget. . .

We made lists, read articles, talked to other cruisers. Still, there were a few things we wished we had, or had more of.

1) *Provisions* — You won't want to bring more of everything, just those things that are *tres cher* in French Polynesia. Beer, wine and alcohol are heavily taxed. A bottle of Absolut costs \$50-\$70. Snacks (chips, crunchies, nuts, dried fruits) tend to be expensive as well. If you're leaving from Mexico, bring lots of canned Mexican goodies (refried beans, jalapeños, salsa, etc.) so you don't have to go into withdrawals too soon.

2) *Gifts* — Polynesians are big givers. Be careful. If you admire something in someone's house, you may be forced to take it away with you. It's nice to have good stuff for trading and to give as gifts. Sunglasses, flip-flops, perfume, nail polish, fishing gear, rope, surf shorts, all come in handy. Save your pencils and school supplies for farther down the line; the French have created a well-supplied school system in French Polynesia.

3) *Engine Oil* — It's expensive, if you can find the kind you like to use. And don't forget transmission oil and outboard oil.

4) *Fish Book* — If you like being in the water and enjoy knowing what you're looking at, get a couple of good South Pacific reef fish identification guides. They won't ensure you'll figure out what that crazy, orange-and-neon, blue paisley thing is that's nipping at your mask, but guides will expand your knowledge of, and admiration for, these remarkable

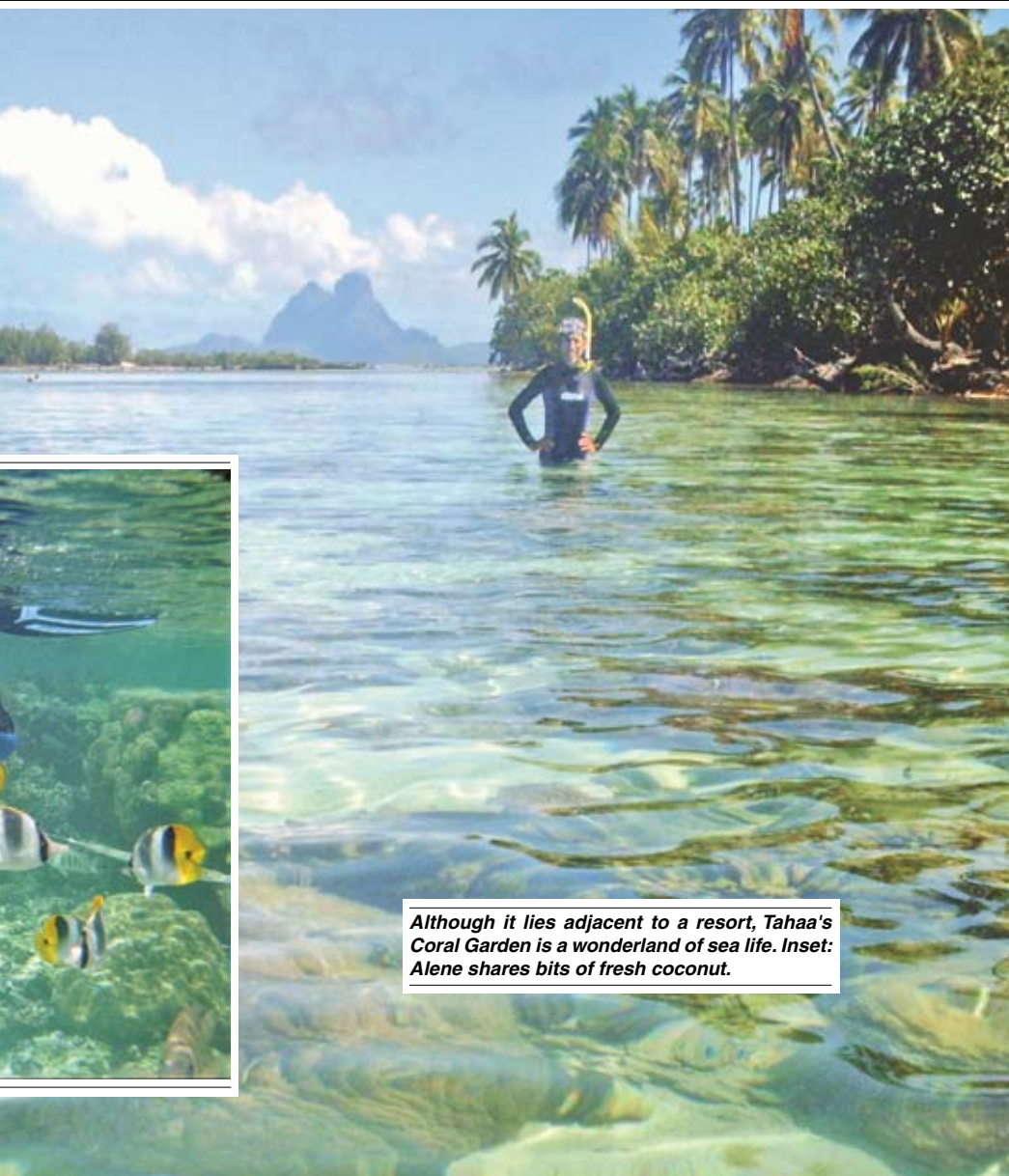

**Although it lies adjacent to a resort, Taha'a's Coral Garden is a wonderland of sea life. Inset: Alene shares bits of fresh coconut.**

# ADVENTURE AWAITS —

ecosystems.

5) *Plan Ahead* — Time your travel to maximize your time in French Polynesia. Don't leave so late that you can't even spend your entire 90 days before rushing off to get to New Zealand before mid-November. Many skippers think it's fairly safe to arrive in the Marquesas during the cyclone season in February or March — especially during La Niña years. Think about being someplace interesting for *Heiva* in mid-July, or Autonomy Day in late June. It's hard not to be rushed with

only 90 days. Better to really get to know a few places than move around fast and miss the subtleties. If you can swing it, get a long-stay visa (up to one year) in the U.S. so you have all the time you need.

### Don't Believe. . .

When we were in Panama and Ec-

uador, we listened to the SSB nets and read posts on the Internet. There were so many opinions and rumors flying around. We started making a rumor list so we'd remember them and find out for ourselves what was true or not.

1) *French Polynesians Don't Like Americans* — We heard this a lot and it

*Clockwise from upper left: Tuamotu tug-of-war during the 'Heiva' festivities; Alene strikes a pose with Marquesan dancers; traditional moves; 'Migration' lies in Anaho Bay, Marquesas; all ages dance; hiking always yields grand vistas; Tuamotu kids dive off the tri's deck; javelin throwing contest.*





# A FRENCH POLYNESIAN PRIMER

ALL PHOTOS ALENE D. RICE & BRUCE BALAN

couldn't be farther from the truth. The French Polynesians were welcoming and warm. If kids knew any English at all, they loved to try it out on us — even just counting to ten. If adults could say "Have a nice day," they always would. We heard over and over how locals wished more Americans spoke French so they could get to know them better.

2) *It's Expensive* — Obviously this depends on the exchange rate. Dur-

ing our year here it varied from 72 to 94 Polynesian francs to the dollar — a huge difference. French Polynesia is not cheap, but you can get by quite easily if you don't eat out and don't buy strawberries flown in from New Zealand. Some items are surprisingly inexpensive. You can get frozen Tyson chicken legs for only about 15% more than the cost in the U.S. Look for the red PPN labels on staples like flour, sugar, canned meat,

and milk; these are all subsidized by the government. Baguettes are about 60 cents. One cruising couple complained that they dropped forty bucks at the McDonald's in Papeete. Our solution to that: don't go to McDonalds. In the public market you can get a big sandwich — a baguette stuffed with chow mein — for less than two dollars.

3) *Arrive with Lots of Cash* — Not true. There are banks and ATMs in most towns (although not in the smaller villages), including all three of the ports of entry



# ADVENTURE AWAITS

in the Marquesas. You can post your bond using your credit card (there are fees associated with this), or buy a fully-refundable one-way airline ticket instead. In the larger towns, many grocery stores accept credit cards. If you are planning on spending a lot of time in the less-visited islands of the Marquesas or the Tuamotus, you'll want to get your Polynesian francs in the towns before you head out.

#### 4) *It's Difficult To Anchor*

— It's true that sand bottoms in twenty feet aren't as common as they are in the Sea of Cortez. And there are some spots that are pretty tough; you'll certainly have the chance to learn how to deal with coral heads. But there are still plenty of nice anchorages. And don't rely only on the cruising guides. A popular guide to the Marquesas says never ever anchor at Hatiheu. We spent three great nights there.

Everything changes. The easterlies

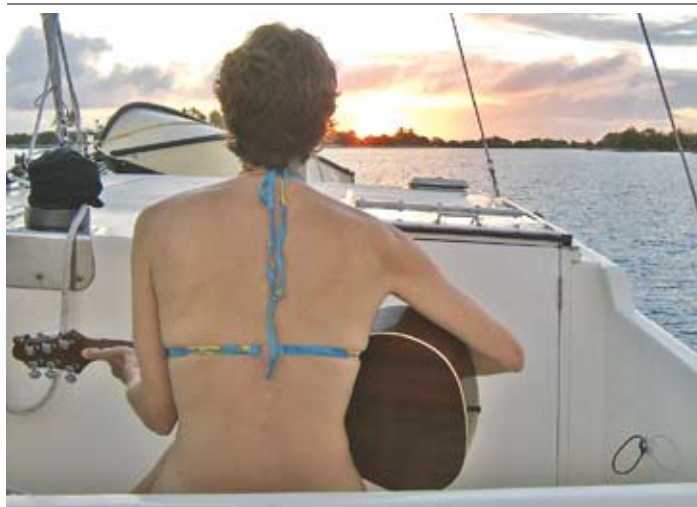

BRUCE BALAN

*It's easy to find solitude in the Tuamotus. Alene serenades the sun as it descends beyond a motu. Just another day in paradise.*

are more northerly in the early part of the year and southerly later on. That makes an anchorage that's perfect in March, awful in August. Look at the charts. Ask other cruisers. Ask locals. Find your own spots — especially in the atolls where you can pretty much anchor anywhere you find good protection from the trades and a nice patch of sand. A lot of chain

certainly helps. Though it's a lot of weight in the bow, we were never sorry to have our 250 feet of high-test 3/8".

5) *Don't Believe Everything You Hear* — Everyone has an opinion, except cruisers — they have three or four. The perfect bay where we spent two heavenly weeks might be pure hell if you're there in a nasty blow. Take everything you hear or read — including this article — with an ocean of salt.

To the west there are thousands of islands waiting for us to explore. Old-timers say that French Polynesia is ruined. The real unspoiled Pacific lies in Vanuatu, or Tuvalu, or Papua New Guinea. . . but that doesn't matter. To get to those places you have to sail right through here. And, unless you like sailing upwind, chances are you won't be back again until you've gone all the way around. So enjoy every minute of it. It really is paradise.

— **bruce balan**



**We're so close,  
you could swim over for  
WINTER DISCOUNTS!**

## SAN FRANCISCO BOAT WORKS

835 Terry A. François St., San Francisco, CA 94158  
(415) 626-3275 Fax (415) 626-9172

[www.sfboatworks.com](http://www.sfboatworks.com) info@sfboatworks.net

*Be our guest for lunch at the historic Ramp Restaurant\**

\*Some restrictions apply



***Happy 2010!***

**Big "thanks" to our  
RETURNING customers  
for your loyalty and trust!**

**Big "welcome" to our  
NEW customers from the  
former Anderson's Boat Yard  
and Sausalito!**



# Designed to the max

470 > 320 350 New375 400 430 New545 630e [www.hanseyachts.com](http://www.hanseyachts.com)

## Compare our pricing against the competition

- ⚓ Ground breaking interior design
- ⚓ Self-tacking jib engineered into the HanseYachts design
- ⚓ Multiple layout options (Individual Cabin Concept)
- ⚓ Epoxy hulls (option up to 54 ft)
- ⚓ Modern, award winning performance cruisers
- ⚓ Safe, comfortable, fast & easy to sail

**Hanse Yachts US** | Ph: 1-410-571-5881 | [aharrison@hanseyachts.com](mailto:aharrison@hanseyachts.com)  
 Annapolis MD | Norwalk CT | Manchester MA | Huron OH | Chicago | Toronto Montreal |  
 Vancouver | San Francisco | San Diego | St. Petersburg FL

A BRAND OF THE HANSEGROUP

See us at the Seattle Boat Show Jan 29 - Feb 6

# HYDROVANE

SINCE 1968

## Survive Your Dream

### 'Great Atlantic Gear Test'

Always rated #1 or #2!



YACHTING

MONTHLY October 2006

100

Best bits of gear - ever.

HYDROVANE included twice!

HYDROVANE IS BOTH:

- ★ Self Steering
- ★ Best Emergency Rudder

## SHOWERS EVERY DAY!

### ECH<sub>2</sub>O Tec Watermakers

## BUILT TO LAST!

604-925-2660    [www.hydrovane.com](http://www.hydrovane.com)    [info@hydrovane.com](mailto:info@hydrovane.com)

# COAST MARINE

## & INDUSTRIAL SUPPLY INC.

398 Jefferson St. San Francisco - On the Wharf.

Call **Bruce Becker** or **Clark Atkinson**  
 (415) 673-1923    (415) 516-4860

**800-433-8050**  
 Fax (415) 673-1927



## LIFE RAFT

### Sales & Service

**U.S.C.G. Approved Testing Facility**

- ★ U.S.C.G. life raft facility for Solas commercial yacht and fisherman rafts
- ★ COMAR DEBARKATION LADDERS
- ★ COMAR PILOT LADDERS
- ★ COMAR WORK LADDERS
- ★ All U.S.C.G. approved





**GUINNESS**  
WORLD RECORD

"World's longest tested ladder 320ft."

Major Distributor for:



**Pains Wessex**  
Safety Systems





## STEARNS®

IN SAN DIEGO CALL OCEANS WEST 619 544-1900

# THE LOSS OF JOJO

In the December 2 edition of *Lectronic Latitude*, we ran Karl Livengood's account of losing his and his wife Betsy's Walnut Creek-based Catalina 36 *JoJo* on the beach at Stillwater Cove, Carmel, on October 20. And we ran Livengood's complaints that the Coast Guard hadn't done enough to save their boat:

"About an hour into it, the Coast Guard arrived and sat about 150 yards away in their 47-ft patrol boat, watching the drama for another hour, but not offering any assistance," said Karl. "I feel that the practice of good seamanship and the 'Good Samaritan Rule' were violated by the Coast Guard's not helping me to secure *JoJo*. They arrived unprepared to help us, having no inflatable boat or wet suits so they could reach us near shore. If Betsy had broken her leg, what would they have done to help rescue her? Their statement that 'We only save people, not boats,' seems to ignore the environment and puts boaters at more risk, since some of us want to do what's right for both the environment and our boats. Our image of the Coast Guard as the ultimate helper when serious problems arise has been shattered. Calling a marine tow service would probably produce better results."

In order to get an idea of how knowledgeable typical mariners are about the Coast Guard's rescue policies and resources, as well as the availability of towing and salvage resources along that part of the coast, we ran the item without printing the Coast Guard's side of the story or additional information. But we did ask readers for their opinions. (See *Letters* for a number of responses.)

The results were illuminating. The majority of mariners don't have a very good idea of the Coast Guard's mission or policies with regard to saving people and boats, and how they dramatically changed in the early '80s. There is also a major misunderstanding of what equipment they carry, and the limits of how close they can operate close to shore.

To get a better understanding of these matters, we spoke with Lt. Michael Kahle, the commanding officer at Station Monterey.

"The Coast Guard's number one priority when responding to a *mayday* call is the preservation of life," said Kahle. "In some situations, that could necessarily require towing a boat or trying to pull it off the rocks. But the Coast Guard will only attempt towing or salvage when our actions don't further endanger the boating public, our own crews, or our ability to respond to a higher priority emergency. In addition, any towing or salvage operations conducted by the

Coast Guard need to be carried out in accordance with the Maritime SAR Assistance Policy (MSAP). Dating back to 1982, this policy limits Coast Guard interference with commercial salvage companies, and basically set up ground rules for when and how we can conduct such operations. This doesn't mean we can't conduct towing or salvage. We look at the risk versus gain for every mission we conduct. When towing and salvage is necessary to protect lives or prevent substantial environmental damage, we will do so. But when it is not an emergency, the MSAP requires the Coast Guard to offer these cases to commercial salvage companies."

Some of us older sailors were around in '82 and remember that change well. If your boat ran out of gas in the middle of the Bay or halfway to Catalina and your life was not in immediate danger, the Coast Guard could no longer bring you 10 gallons of gas or tow you to shore. You had to rely on the help of

other mariners or call one of the towing services that began to spring up to fill the need. Indeed, if your rudder snapped halfway to Hawaii and you thought the Coast Guard would come to rescue you, you had several weeks of drifting toward the islands to get it through your head that they wouldn't. Not unless your life was in immediate danger.

Another thing that most mariners don't realize is that the Coast Guard is strictly a maritime rescue service. "We don't do 'sand' or beach rescues," says Kahle. Those rescues are left up to local emergency agencies such as the fire department, police, sheriff, EMT services or lifeguards, which often work together as a coastal incident response team. But that means if you've run aground near shore, you're normally the coastal incident team's responsibility.

Many of the readers who responded to our *Lectronic* piece said the Livengoods should have called Vessel Assist. Station Monterey covers the area from Piedras Blancas up to Año Nuevo, which is about 100 miles as the crow flies and has an



**Could the Coasties have done more to save 'JoJo'? Yes, but it would have been against the law. Inset: Salvage crews worked through the night to save what they could and to prevent a fuel spill.**

# — THE REST OF THE STORY

even longer coastline. Vessel Assist out of Santa Cruz is the only commercial towing company working that area. As such, they can take hours to reach the scene of a vessel in distress at a place such as Stillwater Cove.

And it's important to note that once your boat touches land or a rock, it becomes a salvage operation, instead of a simple tow. "An easy rule of thumb to tell which service you need," says Chelsea Wagner, owner of Pacific Salvage/Vessel Assist Santa Cruz, "is if you can file an insurance claim, it's salvage."

As it was, the Livengoods were in touch with Wagner very early on. But it takes time to get an operator to the boat, time to get the boat underway, and in the case of covering the 25 miles from Santa Cruz to

Stillwater Cove in less than perfect ocean conditions, a lot of time — in this case, nearly three hours. While Wagner got to the beach at Stillwater Cove before *JoJo* was beyond help, her salvage boat did not.

As wrong as it might seem, as long as no lives were at risk, it would have been illegal for the Coast Guard to try to tow *JoJo* off the beach. If you think this policy is much too rigid and restrictive — as many of us do — don't blame the Coast Guard. It's Congress and the Department of Homeland Security who give them their marching orders.

In addition to being unclear about the Coast Guard's mission, many readers are unfamiliar with what resources the Coasties have and the restrictions on using them. Station Monterey responded to *JoJo*'s mayday with a 47-ft motor lifeboat, a vessel that draws 4.5 feet. By Coast Guard navigation rules, the coxswain operating the motor lifeboat is not allowed to bring the vessel into water where there are known dangers or where there would be less than three feet of water beneath the lifeboat's keel. In other words, less than 7.5 feet of water.



In addition to the strict depth limitations, even in cases where a life is in danger, the coxswain has to conduct a constant risk/reward analysis of any rescue situation. In the *JoJo* incident, weather was not a limiting factor. The wind was just 10 knots out of the northwest, and the swell was less than one foot. The limiting factors were that the coxswain knew there were rocks and reefs in the cove, and that there is extremely thick kelp which could have clogged the water intake to the motor lifeboat's engines and therefore shut those engines down, endangering the crew and rescue boat.

A number of readers asked why the

Coast Guard didn't launch the inflatable dinghy from the motor lifeboat. Lt. Kahle told us that not only do 47-ft motor lifeboats not carry inflatables or launches, but "small inflatable rafts are not a standard Coast Guard platform."

"The Coast Guard's real issue with our assisting the Livengoods," says Kahle, "was not that Mr. Livengood couldn't reach our motor lifeboat, which was a couple of hundred yards offshore, but that he was reluctant to abandon his efforts to salvage his boat so he could transfer his wife to our motor lifeboat."

To our minds, the reader criticism of the Coast Guard that stung the most was that any average sailor would have done much more than the Coast Guard did to save *JoJo*. The criticism stung because it's true. Had our cat been in the area, we'd have jumped at the chance to try to save *JoJo*. And there's no point in lying, we'd have done it more for the adventure than humanitarian reasons. We *loooooove* saving boats! We would have carefully backed our cat as close to *JoJo* as the depth and kelp allowed, and if that wasn't close enough to throw line to *JoJo*, we would have gotten in our dinghy and taken the line the rest of the way in. Then we would have tried to pull her into deeper water. Make no mistake, there are some huge assumptions here. First, that there wasn't much of a swell. And second, that *JoJo* wasn't already too high and dry to be saved. This is not something we'd expect a typical mariner to do, because it has the potential of being very dangerous.

If you're reading this thinking, isn't there any agency that should have come to *JoJo*'s help? There is. In the Monterey area, as well as almost everywhere along the coast of the United States, there are

government agencies — police, fire, EMS, lifeguards, sheriff — that form coastal incident response teams for emergencies along the shore. When a

boat is in the surf, on the rocks, or on the sand, the coastal incident unit takes over.

For example, when we rescued the crew of the flipped trimaran *Existential Blowout* about a half-mile off the coast of Pt. Dume during the '08 King Harbor Race, the shore was lit up like a casino from all the flashing lights of the emergency vehicles. And despite our repeatedly telling them all that the entire tri crew

*"The Coast Guard's number one priority is the preservation of life."*



ALL PHOTOS COURTESY, JOJO

# THE LOSS OF JOJO

had been recovered and were in good health, not one, but two emergency agencies sent two-man teams out to our boat. We presume that they thought either we were lying or that they were padding their rescue statistics to justify larger annual budgets.

We asked Lt. Kahle why nobody from the Monterey coastal incident team responded to the *JoJo* incident. "Had we known that *JoJo* was near the beach at Stillwater Cove, we would have called the coastal incident response team immediately because, as I mentioned, the Coast Guard does not do 'beach rescues'. Since the initial transmissions between *JoJo* and the Coast Guard were very poor, our early information had *JoJo*'s position as being farther to the north rather than at Stillwater Cove, so EMS was not contacted until we were already on scene. As soon



**'JoJo' was refloated and hauled by Monterey Boat Works, then declared a total loss.**

as the Livelihoods were safely on board our rescue boat, my crew provided necessary first aid while we transported them to awaiting EMS."

We're terribly sorry about the loss of *JoJo*, but believe this is what's known in the education business as a

'teaching moment'. Generally speaking, the Coast Guard, by law, can save property only if it's essential to saving lives. Saving property is the province of commercial tow and salvage companies, of which there probably aren't as many as you think. And that once you get close to shore, you're going to be in the hands of the coastal incident team, not the Coast Guard.

According to Lt. Kahle, the only way the Coast Guard will give you a tow

when lives aren't at risk is if "commercial providers decline assistance and our risk assessment determines that the towing or salvage can be conducted without negative repercussions." But it would be unwise to expect such a service.

The best thing to do is stay out of trouble, and if you start to get into it, know how to get out of it. Like granny said, a stitch in time saves nine.

— **latitude**/richard

## SAL'S

INFLATABLE SERVICES, INC.



*Racers... Call Sal & Silvia!*

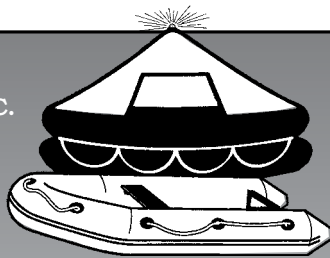

We rent:  
Liferafts, GPIRBS,  
EPIRBS and more

### SALES • SERVICE • RENTALS

- GPIRBS
- LIFERAFTS
- EPIRBS
- FLARES
- SURVIVAL SUITS

***EPIRBS are now required for all OYRA races.***

USCG APPROVED LIFERAFT FACILITY for USCG/Solas, Yacht and Fisherman Life Rafts. Life raft sales for Avon, Mitsubishi, Fujikura, DBC, Givens, Plastimo, RFD-Revere, Switlik, Viking, Winslow and Zodiac. Inflatable boat sales and warranty repairs for Avon, Achilles and Zodiac. Sales of ACR and McMurdo EPIRBS, signal flares USCG/Solas type and Survival Technologies MOM units.

**PHONE (510) 522-1824 FAX (510) 522-1064**

1914 Stanford Street, Alameda, CA 94501

salsinflatables@sbcglobal.net • www.salsinflatableservices.com



FOR WORLD-CLASS STEINER BINOCULARS:

## Start Here.

**Steiner Commander V** delivers 96% peak light transmission for unparalleled performance at night and in low-light. The brightest binoculars made, they're waterproof, shock resistant and come with a 30-year warranty. Call or click for a free catalog or to sign up for our monthly Landfall Report e-mail. Shop online anytime.

**Landfall**  
WHERE SAFE VOYAGES BEGIN

**800-941-2219 | landfallnav.com**

**SAFETY | NAVIGATION | REFERENCE | WEAR**

©2010 Landfall Navigation. All rights reserved.



**MARINE INSURANCE SPECIALISTS**

*Your best source for Yacht and Boat Insurance  
tailored to your needs and competitively priced*

**We Insure:**

Sail or Power ♦ Classic or Contemporary  
Fiberglass ♦ Aluminum ♦ Steel ♦ Wood

At Heritage Marine Insurance you will find knowledgeable insurance professionals who provide the best service and the finest coverage available today.

*Please contact us for a quote*

[www.heritagemarineinsurance.com](http://www.heritagemarineinsurance.com)

**800-959-3047**

Fax 860-572-5919

Email: [classics@heritagemarineinsurance.com](mailto:classics@heritagemarineinsurance.com)



**OYSTER POINT  
Marina/Park**



*A full service marina located in  
South San Francisco with berthing  
and guest dockage available*

For information and pricing call

**(650) 952-0808**

[www.smharbor.com/oysterpoint](http://www.smharbor.com/oysterpoint)

**SAIL TO  
OUR NEW  
MARINA**

**NEW SLIPS  
COMING SOON  
Limited Availability  
RESERVE  
TODAY!**

**Great Long-Term  
Lease Deals**

- Up to 15 Years •
- electricity
- deli facilities
- fire fighting system
- waste disposal
- fuel dock
- 24/7 security
- wi-fi

LAT. 20°41' 22"N • LONG 105°17' 28"W



[WWW.MARINANUEVOVALLARTA.COM](http://WWW.MARINANUEVOVALLARTA.COM)

MONITORING VHF 16

PH: 52 (322) 29 77 000

HARBOR MASTER: JUAN S. ESTRADA

[JUAN@MARINANUEVOVALLARTA.COM](mailto:JUAN@MARINANUEVOVALLARTA.COM)

# SEASON CHAMPIONS, PART III

It's time for the third and final installment of our Season Champions articles, where we profile winners from the Bay's classic one design, dinghy and shorthanded fleets. In these pages, you'll have a chance to meet some of the division winners from this year's one design racing. We've got winners from the YRA's Wooden Boat Racing Association (WBRA), the Etchells fleet, El Toro and Wylie Wabbits, plus the winners of both the Bay Area Multihull Association (BAMA) and the Singlehanded Sailing Society (SSS).

The Singlehanded Sailing Society had a banner year, drawing record turnouts for its season, which start with the iconic Three Bridge Fiasco in January, which this year drew over 300 boats! The Corinthian Race saw a big jump in participation this year as well. There was also a good turnout for the LongPac — or Great Pacific Longitude Race — a choose your own route out to 126° 40' and back. It's hard to say exactly why, but the SSS seems to be attracting both its long-time stalwarts and newcomers with its unique schedule and run-what-you-brung ethos.

BAMA also had a good year, and its Doublehanded Farallones Race — open to lead mines as well — is certainly another of the Bay's iconic races. BAMA Race coordinator Christopher Harvey said that this year's improved turnout should hold for next year.

"It was a great year to be sailing multihulls on the bay," he said. "The multihulls saw a 25% increase in boats at the start line, and rumor has it that increased multihull participation will continue into the coming year.

On the wooden boat front, the Folkboats sailed their Internationals on the



PETER LYONS/WWW.LYONSIMAGING.COM

JIM MARGESON



PETER LYONS/WWW.LYONSIMAGING.COM

Bay this year which drew teams from all over Scandinavia, while the Knarrs were their typically competitive selves despite this being an "off" year for the IKC on the Bay. The IODs and Bird boats round out that group.

The Bay's Etchells Fleet 12 saw a sharp uptick in participation for

**Spread — the Folkboats bash around the Circle at their Internationals; insets, clockwise from top left — Vanguard 15s; a load of Bullshippers; Etchells steamroll downwind on the Circle; less is more for the short-handed sailors.**

the venerable one design.

Our apologies to those division winners who don't appear here, but we just didn't have the space to profile all the one



# — ONE DESIGN, PART II, SSS, BAMA



## MORE CHAMPIONS:

BIRD — 1) **Robin**, Patrick & Cissy Kirrane; 2) **Polly**, Bill Stucky; 3) **Curlew**, Heinz Backer. (6 boats)

IOD — 1) **Fjaer**, Richard Pearce; 2) **La Gatita Mojada**, Jeffery and Danielle Lawson; 3) **La Paloma**, James Hennefer. (8 boats)

design and dinghy winners. We based our choices largely on the number of total races sailed among the divisions.

We hope you enjoy meeting these ardent racers as much as we have. We'll leave you with a parting thought: The folks you'll see here sail in a wide range of boats, in a wide variety of venues both inside and outside the Bay; they

hail from a variety of clubs all connected to the Bay, whether their clubhouses are physical or digital. To our minds, it shows that *anyone* can do it with a little dedication of the most enjoyable kind. If you're not already doing it, what are you waiting for?

— **latitude**/rg

# SEASON CHAMPIONS, PART III

## SSS Singlehanded *Outsider*



**Greg Nelsen**  
**SSS**

Oakland-based Greg Nelsen might be a self-described "late-bloomer," having not started racing until his mid-20s, but he hasn't let that keep him from racking up a lengthy resume of season championships in the Singlehanded Sailing Society — this is his seventh!

But he didn't take it easy this year, even after a strong finish in the non-discardable LongPac.

"I knew that [winning] was a strong possibility," he said. "But you're just one mistake away from having it slip through your fingers, so I just focused on one race at a time."

Nelsen — who also won the '00 Singlehanded TransPac and the singlehanded '01 LongPac — said there weren't any secrets to his win.

"Thinking and planning ahead when shorthanded is certainly key to consistent performance," he said.

The project manager — his charges include the Fox 44 *Ocelot* — who has also been focusing on emerging energy systems for marine applications, including lithium battery and fuel cell technologies, Nelsen manages to fit a lot of ocean racing into his schedule in addition to the SSS schedule. He sails the latter aboard his *Azzura 310 Outsider*, the Alameda-built boat he rescued from the East Coast where it had been sitting without a rig.

As for what's next in '10, Nelsen says he's hoping to do the PV Race and Mexorc, some coastal racing and that, "Hawaii in some flavor would be nice."

2) **Taz!!**, Express 27, George Lythcott; 3) **Coyote**, Beneteau 42, Steve Hill. (47 boats)

## SSS Doublehanded *JetStream*



**Dan Alvarez**  
**SSS**

Dan Alvarez' JS9000 *JetStream* isn't the most conventional-looking boat on the water. It's really narrow and a high-aspect sailplan leaves a few feet of bow beyond the headstay.

"We get stares everywhere we go," he said. "It's funny looking all right; it's fast-looking too; and it is indeed a fast boat. It's a boat that I had been looking at ever since I got hooked on shorthanded sailing. It really is an optimal platform for single- and doublehanded racing. It has a small sailplan which makes it ideal for the summer conditions in the Bay, and it's really at home in the 20-plus-knot range."

Joining him aboard the boat was Mark Hadfield, who had sailed with Alvarez on his previous boat, an Ericson 30+ *Travieso*. The two have been sailing together for over three years.

"To win you have to race and we did all the races in the calendar," Alvarez said. "We avoided major mistakes and had consistently good boat-handling — which is greatly facilitated by an easy-to-handle boat."

For Alvarez and Hadfield, that consistency paid off in the end, when they won the season in the final race, beating out David Hodges and Scott Parker on the Farr 38 *Timber Wolf* and Rachel Fogel's Express 27 *Great White*.

While he loves the shorthanded sailing, Alvarez, a Pleasanton-based software engineering manager, also gets in plenty of ocean racing also, aboard the Fox 44 *Ocelot* along with Nelsen.

2) **Timber Wolf**, Farr 38, David Hodges; 3) **Great White**, Express 27, Rachel Fogel. (81 boats)

## BAMA *Roshambo*

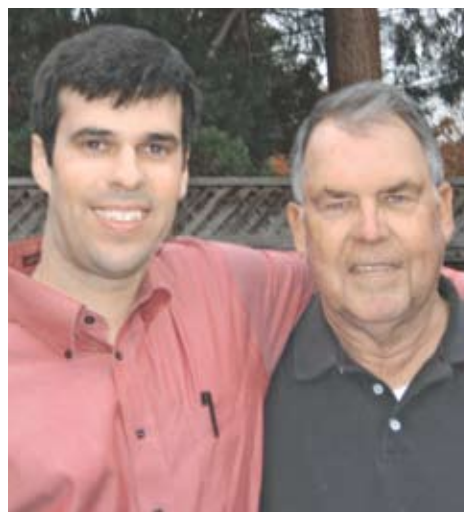

**Darren Doud**  
**BAMA**

He's only been sailing multihulls since '06, but that didn't stop Darren Doud from becoming this season's Bay Area Multihull Association season champion and winner of the BAMA Cup.

After campaigning a Moore 24 with his dad Dan for the better part of ten years, sailing mostly doublehanded, Doud was looking for something bigger and happened on *Roshambo*, an F-31R.

"My wife Lauren wanted standing headroom and a real head, not a bucket," Doud said. "We looked at monos but nothing fit the requirements. Once we had *Roshambo* on a reach going across the slot at a constant 18 knots, I was hooked, and quickly became addicted to the speed."

Doud and his rotating crew of his dad, Phil MacFarlane, Matt Siddens, Ruben and Robbie Gabriel, Cuyler Binion, Synthia Petroka, Steve Green, and Christopher Harvey — the '07 and '08 BAMA Cup winner — won the season by a mere three seconds in a race that broke a tie with Bill Gardner's F-27 *Peregrine Falcon*.

Doud said that owning a multi isn't just about blasting across the Bay.

"Lauren and I have also enjoyed anchoring in the lee of Angel Island and lounging on the nets with friends during the summer," he said.

The rest of the competition will be able to breathe a little easier next year. The Douds will be welcoming a baby girl into the family, so their sailing will be scaled back in '10.

2) **Peregrine Falcon**, F-27, Bill Gardner; 3) **Native**, Newick 38, Stephen Marcoe. (37 boats)

# — ONE DESIGN, PART II, SSS, BAMA

## Etchells JR



### Bill Melbostad/Bryan Moore SFYC

The Bay's Etchells fleet is stocked with talent, so when you can theoretically sit out the last two regattas and still win the season championship, you're doing a lot of things right. That's exactly what partners Bill Melbostad and Bryan Moore did this season. And, they didn't sit out the last two regattas.

"We probably didn't need to sail the last two regattas," Moore said. "But it's all about improving and it's best for the fleet when everyone is sailing."

While maybe not *everyone* was sailing this year, the fleet did have a big jump in participation, regularly getting 14 boats on the line for events all over the Bay.

After six years in the fleet together, the duo, along with long-time bowman — and substitute helmsman when Melbostad is unavailable — Steve Fentress, have notched plenty of wins including most recently, the '07 season championship.

Moore, a construction manager, Melbostad, a marine surveyor, and Fentress who's in sales — pictured above from left to right — don't do it all by themselves. They call on the help of Olympic bronze medalist and Bay Area product Jeff Madrigali for sails and tuning advice.

But the sailing together they've done for the last 12 years or so on various boats before the Etchells, including the Melbostad family's Soverel 33 *Navigator Again*, notched wins for both Moore and Fentress — they were introduced to their respective wives Suzie and Mimi.

2) **Mr. Natural**, Ben Wells; 3) **Dinner Roll**, Jeff Moseley/Bill Barton. (14 boats)

## Knarr Fifty/Fifty



### Jon Perkins St. Francis YC

With a history in the Knarr fleet that goes back 30 years, and plenty of top finishes in that time, Jon Perkins finally notched his first season championship this year. It didn't come easily, as the guy he was battling for the top spot happened to be his brother Chris, who's notched a few top finishes of his own.

"It was pretty tight the whole season," Perkins said. "We feel very fortunate to have won it; it could have gone either way. For about the last five regattas we were within three or four points of Chris and trading the lead back and forth the whole time."

Perkins has been sailing with his core crew of Tom and Melissa Purdy — all three also sail with Chris on his J/105 *Good Timin'* — since they were kids growing up at San Francisco YC. Their fourth, Robert Francello, has been with the program for six years. Their commitment paid off. They got a little help from an unusually light end of the season.

"Historically as it gets windier and windier throughout the season we have more problems because we sail the boat really light," Perkins said. "This year, it actually kept getting lighter and lighter as the season went on. Those were our conditions, not only because we're light, but because our boat just handles a lot better in light air."

Despite the closeness of the standings, Perkins said that he and Chris only match raced in one race, and it didn't end up well for either boat.

2) **Three Boys and a Girl**, Chris Perkins/Hans Baldauf; 3) **Knarrmageddon**, Tom Dobroth/Mike Peterson. (22 boats)

## Folkboat Windansea

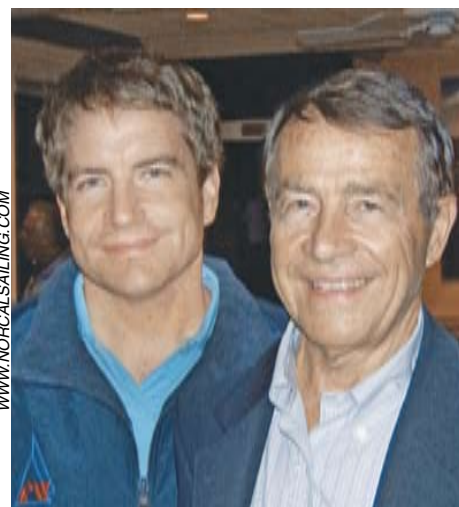

### Dave & Don Wilson St. Francis YC

Don and Dave Wilson's Folkboat *Windansea* has been in their family for close to 30 years. In that time, they managed to rack up an impressive number of wins in the class. *Windansea* came over from Scandinavia in a container for the class' Internationals back in '81, when Don Wilson purchased her.

She came full circle this year when the Wilsons, along with substitutes Tom Urbania and Mark Van Crienkge won both the Internationals, and the Season Championship — the family's third-consecutive and fourth in total. The Wilsons were once again in a pitched battle just like last year with Eric Kaiser's *Josephine* for the top spot in the season.

"We didn't think it was really going to happen," Dave — the primary helmsman this year — told us at the Internationals at the end of September. "Eric's been really consistent this whole year, so we feel really lucky to have pulled it out."

The Wilsons scored eight bullets — including five straight in the heart of the season — out of the fourteen races that counted for the WBRA portion of the Folkboat Season Championship. They finished only eight points ahead of Kaiser in the 20-race overall series. The Wilsons three drop-races? All thirds!

Dave was quick to point out that winning the Internationals on the Bay, while gratifying, involved a certain degree of local-knowledge edge.

"We went to the Gold Cup in Sweden last year and finished 19th," he said.

2) **Josephine**, Eric Kaiser; 3) **Elsie**, Mike Goebel. (14 boats)

# SEASON CHAMPIONS, PART III

## Wylie Wabbit Weckless



**Tim Russell**  
SFYC

You probably recognize Tim Russell from past editions of these pages, but you probably associate him with his J/105 *Aquavit*. But Russell is also an avid Wylie Wabbit sailor and when he put the J/105 on the market earlier this year, he turned his attention to *Weckless*. The result: wins in both the Bay series and the Travel Series.

"This is the first year that I sailed everything," Russell said.

He came to the boat four years ago after deciding he'd had enough with the Laser sailing he was doing concurrently with the J/105 sailing.

"I used to race my Laser quite a bit, and I was looking for another boat that has the same appeal, but where you get to share the misery with some other people on the boat," he said, laughing. "I love the boat, it's just a great boat to sail, you still have the physical, dinghy aspect of it; I like the fact that it goes downwind like a dinghy but upwind like a big boat."

The dual nature of the boat also extends to the events it gets invited to.

"What else can you sail, where you get invited to all the keelboat regattas and get to do all the dinghy races at Richmond YC too?" Russell said.

Russell, a Novato-based wealth manager, was joined this year by his trapeze artist John Claude — who only missed one regatta — and a rotating group that included Scott Parker, Raand Phibbs and Wayne Sharp.

2) **Mr. McGregor**, Kim Desenberg/John Groen;  
3) **Kwazy**, Colin Moore. (16 boats)

## El Toro Sr.



**John Pacholski**  
Santa Cruz YC

The winners in some classes are decided by the time the season is half-finished, but not the El Toros. When asked when he felt he'd had the season pretty well wrapped-up, John Pacholski's answer came as a surprise.

"When the final results were posted to the website," he said.

Pacholski finished the Toros' lengthy season a single point ahead of runner-up and "arch-rival" Art Lange, and two points ahead of third-placed Fred Paxton. Meanwhile, son Mike, winner of the season championship for the juniors, narrowly beat out friend and fellow-Santa Cruz YC member Mackenzie Cook by only one point as well.

While their respective divisions were certainly close enough, the elder Pacholski says the gap between the two of them is quickly eroding.

"Mike beat me for the first time, fair and square, at Lake Merritt last year," John said. "He sailed a great race and his boathandling skills were better than mine. I was very proud of him. Now I have my hands full just trying to stay ahead of him."

The pair are avid campaigners in the class and sailed 30 regattas this year.

"Mike and I spend a lot of time in our boats," John said. "We also spend a lot of time talking through local conditions and racing strategies, learning from each other. It's really 'team' Pacholski that wins."

John, a "finance guy" for early stage internet and software startup companies, started in the class in '98 after crewing

## El Toro Jr.

**Mike Pacholski**  
Santa Cruz YC

on an Express 37 and a Cal 3-30.

Mike, a seventh-grader, started sailing only four years ago with Paul Tara's Santa Cruz YC junior program, with John on a Wyliecat 30 they shared.

For the younger Pacholski, he's looking forward to stepping up to larger dinghies in the not-too-distant future, but for now, he'll be riding his bull.

"Toros are great boats for learning," Mike said. "I'll be doing Stockton Sailing camp and the Jr. Nationals there definitely."

Looking forward a year, he said he's begun exploring the world of FJ's and 29er's. But for now it'll be all Toros all the time, and a lot of time together as a result.

"Our affection for these boats is in part because we get to work on our boats side-by-side on the front lawn and then race side-by-side in many regattas," John said. "The boat is ideal for father-son or mother-daughter enjoyment of sailing."

Although the season championship is a relatively new development for the El Toros — it's only been around for a few years in fact — this year marked the first time that a parent-child combo has taken both the senior and junior season titles. Tara and son Patrick won their respective divisions at the class' nationals in 2005; in 1975-76 Aad Rommelse and daughter Loretta did the same.

EL TORO JR. — 2) Mackenzie Cook; 3) Haydon Stapleton. (11 boats)

EL TORO SR. — 2) Art Lange; 3) Fred Paxton. (28 boats)

# BERKELEY MARINA



**Centrally located off Hwy. 80 at University Ave. • Fast Access to the Central Bay • Fuel Dock • Marine Center with 35 Ton Lift Capacity • Launch Ramp • Waterfront Hotel • Restaurants • Adventure Playground • 17 Acre Off-leash Dog Park • Picnic Sites • Deli and More...**



**CITY OF BERKELEY**  
PARKS RECREATION AND WATERFRONT

**Berkeley Marina Office**

**201 University Ave. • 510-981-6740**

Visit our website at: [www.ci.berkeley.ca.us/marina](http://www.ci.berkeley.ca.us/marina)



**McGinnis Insurance**

*Since 1972*

**Knowledge  Commitment**  
**Reliability  Service**



**Happy New Year!**

**Call us at: 800-486-4008**

**[mcginnisins@aol.com](mailto:mcginnisins@aol.com)**

License #0570469

**45 TONS OF CRUISING KETCH  
THAT LOVES OFFWIND SAILING.  
YEARS AND YEARS OF IT!**



Richard Mulvania installed a UK-Halsey asymmetric pole-less cruising spinnaker on his Golden Skye in 2002 and won PHRF in the Ensenada Race. The same sail is still winning silverware. The Flasher is simple to fly. A video on our website shows how easy it is to gybe.



**510-523-3966 [ukhalsey.com](http://ukhalsey.com)**

There is a certain unique quality to California sunlight, even in January. It hit me the second I stepped through the doors from what had once been the baggage claim area onto the sidewalk at SFO. Well, actually the strong smell of bio-jet-fuel that characterizes all airports these days hit me first, but the quality of the light and the subtle smell of the Pacific marine layer brought back deeply ingrained memories. I had been away from the Bay Area for too many years.

It's a long story. First there was my promotion, then a transfer to the eastern division. Twenty years and three oil price spikes later, and air travel had become so expensive that it was hard to justify a trip back to San Francisco. And the planes had become larger and slower and ever more crowded to save fuel, and a lot less comfortable than they had been back at the turn of the century.

But I had finally made it back. I'd survived the ordeal of trans-continental travel, and took in the air and sunshine for a few more minutes before starting to wonder what had happened to Lee Helm, who was supposed to pick me up at the airport. I was about to check my phone for her range and bearing when her car, a small thing with a surprisingly blunt nose and tail, pulled up to the curb.

"Max!" she hailed. "Hop in!"

My carry-on bag just fit on one side of the car's tiny luggage compartment, and Lee's wetsuit, which had been on the passenger seat, filled up the other half when she cleared the seat for me.

She pushed the speed control forward and the car silently sped toward the freeway.

"Snappy acceleration for one of these little electric go-carts," I noted.

"It's my new flywheel hybrid," she boasted. "I get, like, almost total regenerative efficiency."

"What was wrong with electric regenerative braking?" I asked. "Or was that last year's thing?"

"That was trailing edge tech for sure. Cars have to be able to stop much faster than they accelerate," Lee explained, "so for full regeneration, the motor/generator has to be sized for braking power, which makes it big and heavy and expensive. But, like, with the flywheel, even hard braking puts all the power back into flywheel storage, and the mechanical efficiency is much better than turning the power into elec-

tricity, storing it in a battery or capacitor and then taking it out of the battery and turning it back into mechanical power. The flywheel works great in stop-and-go traffic, and going up and down short hills. And there's a small electric motor to, like, keep the flywheel spooled up."

I noticed another interesting feature in the car as Lee navigated the access ramps to the freeway: something that looked like a centerboard trunk right down the middle, separating the seats.

"Is there also a gas motor for the long trips at freeway speeds?" I asked. "This car doesn't look very aerodynamic, so I imagine it takes some fossil power just to keep up with traffic."

"I can rent the module if needed," she answered, "but only for going off the guideway."

"Guideway?"

"You don't have them back east?" she asked as she stopped the car in the entrance queue for the on-ramp. "I key in the exit code for the marina, and the guideway does the rest."

After a short wait, the car drove itself onto a kind of monorail track. Lee took her hands off the controls as the car accelerated into traffic.

"Ah, so that's what the centerboard trunk is for," I observed. "The car turns into an automated monorail."

"And gets all its power from the grid," she added. "The monorail design allows for very low-friction wheels, and because the braking surface is vertical on the sides of the rail, it's protected from rain. Reliable braking is kind of important for computer-controlled vehicles."

"I should think so," I said, trying not to flinch at the high speed switching and narrow misses with other cars while no one was driving. "Still, I would think that the aerodynamics would be better. That

flat front can't be very happy moving through the air at this speed."

"We're not done," she said as the guideway computer accelerated

us to the speed of traffic and then some. For a moment it looked like we were going to rear-end the cars in front, but we slowed a bit and gently bumped into the flat transom of what turned out to be a train of about 30 vehicles — all with flat fronts and backs just like Lee's — that almost meshed together.

"Nothing to do now but watch the scenery and check email," said Lee as she



**Cutting edge to cutting room floor** — Innovative designs today, such as 'BMW Oracle 90', seem positively 'old skool' compared to the futuristic designs like Ankida, drawn by Lila-Lou.



put on a pair of glasses that I recognized as the latest model iEye. "Checking the arrangements for today's midwinter race . . . Cool, they have crew spots for both of us. Wait till you see the boat we're on."

"What are they doing for marks these days?" I asked. "Last I heard, the Coast Guard had discontinued all the floating nav aids, and even daymarks are being removed to save maintenance costs."

"Nav aids are so last millennium," Lee confirmed. "And no one was using any of the buoys anyway, now that everyone has a heads-up display in their eyepiece that can project a view of a virtual nav aid right where you need it."

"Do you race around those virtual marks?" I asked.

"They never really worked well for rounding marks," she conceded. "You can't tell when you hit one, and arguments about mark room are hard to resolve. Some clubs still try to set courses 'in silico' using only virtual marks. But, like, we don't really miss the buoys. We just use windmill towers instead. They're all over the Bay now, so we have lots of good courses to choose from."

I could see the wind towers lining the ridge tops as we flew around the steeply banked turns of the old Hwy 101 right-of-way at over 100 mph. Lee claimed that the Caltrans wind farms were more than enough to power the entire guideway

*"Nav aids are so last millennium"*



SPREAD: GILLES MARTIN-RAGET / BMW ORACLE RACING; INSET: LILA-LOU

system.

"Fortunately, they cancelled that high-speed rail boondoggle in 2016 and funded the California Dual Mode Guideway System instead. I mean, trains and buses waste most of their energy moving empty space because they have to, like, have standing headroom and aisles. Not to mention going empty during off-peak or reverse runs. A string of cars like this has a much smaller cross-section and uses only a fraction of the power a conventional train would need for the same number of passengers."

"As if anyone could pry Californians out of their cars," I added.

Lee had barely finished confirming our crew spots when our string of cars split into several sections, then sorted and reconnected according to which cars were going over the Bridge.

As the car drove onto the Bridge, our line of cars had joined up with another line of cars that had approached from behind, and our speed increased again, reflecting, I surmised, the ever-increasing efficiency of a longer string of cars.

After what was surely my fastest trip ever from SFO to the marina, the guideway computer broke up our gaggle of cars just long enough to switch us off to an exit ramp. We rolled to a stop and

Lee took the controls to drive the last half-mile to the yacht club.

But other things had changed: The dry storage area and the small boat hoists and docks were gone, replaced by a large modern building and a landscaped parking lot.

"Lee, isn't that where your college sailing club used to be? Don't tell me they finally sold out and let a restaurant take over the site."

"The sailing area was silting up anyway," she shrugged. "And the marina needed the cash flow

from a market-rate lease."

"That's terrible, losing an institution like the college sailing club. I know it meant a lot to you and your friends."

"Not to worry, Max. The club totally has much better digs now. The ferry terminal was abandoned just a year after it was finished in 2014. They gave us a new breakwater, deep water, good wind, a big parking lot, and a large enough enclosed space for a great clubhouse and an indoor boat repair shop."

I had only a glimpse of the ferry-terminal-turned-community-sailing-center before we rounded the last corner into the yacht club parking lot. Lee parked her short hybrid in a space striped for a full-length car, blocking in another little vehicle like her own.

"Uh, what if they want to get out?"

"No prob. These cars can be robotically controlled. I'll leave it in auto-valet mode, so the parking lot computer can move it out of the way and re-park, if necessary. We can fit a lot more cars in the lot this way."

I could see why they needed more parking. The yacht club had been expanded by the addition of a new and larger dining room, but otherwise it was just the way I remembered it. Same furniture, same trophies and models in the display cases, same pictures of past commodores and their boats on the walls.

And a stack of the latest issue of *Latitude 38* on the table in front of the office. I grabbed one as we walked by and slid it through the handle of my carry-on bag.

We walked over to the windows facing out over the Bay.

"Perfect weather for a race," I observed.

"RC boat is on station," noted Lee. "No spare cycles, we should get going."

"I don't see anything," I said. "Where is the starting line?"

"You'll, like, need the binos to see it," she informed me as we walked toward the door that led to the guest dock. "When I had my cataract surgery I went for the new multi-element zoom lens. I blink three times to zoom in, twice to zoom out, a slow blink resets to wide angle. Works great — I should've done it, like, years ago."

"And I thought I was ahead of the curve with my autofocus reading glasses," I confessed.

I followed Lee down to the guest dock where several boats were almost ready to cast off for the afternoon race.

"Here's our ride," she announced.

The boat was a very fast-looking catamaran. It was hard to judge the length of the long slender hulls — probably 45 or 50 feet stem to stern, and at least 30 feet wide. There were two wing sails, one on each hull, canted in slightly toward each other as on the old Trifoiler. There was no visible standing rigging except a single strut connecting the two mastheads.

"I'll get the spoilers off the wings, Max. You'll be trimmer, so take the covers off the trim console and start the trim engine."

There were two other crew: the owner, who would manage the ballast pumps and steer when necessary, and the weather strategist, who came with his own box of specialized sensing equipment.

"Ballast check?" called Lee.

"Full tanks, both hulls" confirmed the owner.

Hearing that, Lee released the spoiler halyards and pulled them down from the wing sails, then stripped the spoiler halyards off the wings, and stowed spoilers and halyards in compartments in the hulls. Only the tips of the wind sails projected above the wind shadow behind the yacht club, but it was enough to cause the boat to shudder and strain at its mooring lines.

"Anyone have a set of loaner foulies?" I asked hopefully. "This looks as if it's going to be a fast and wet ride."

# MAX EBB

"Just stay inside your canopy, Max, and you'll be fine," Lee assured me. "But you do need to sign the waiver first."

The owner of the boat handed me a small tablet with a stylus attached. There were several pages of text to scroll through.

"Just the usual boilerplate," he said. "Now, let's go sailing."

I signed without any further study and handed the tablet back, then climbed inside my trimming station as directed by Lee.

She reached over to the panel to switch on the power and start the trim engine, then closed the clear plastic bubble around me. The control panel lit up, self-adjusting to the ambient light level, and then displayed an array of indicators and controls that appeared to combine the worst features of top-end digital cameras and SSB radios.

There were controls for sheeting angle, camber, twist, slats and flaps, port and starboard. There were indicators for lift, drag, torque and angle of attack at five different levels, stall warnings and thrust vectors, even a Reynolds number display and a laminar flow indicator. There were relatively standard engine controls, which I thought I could probably understand, and spectral analyzers, which I was sure I could not understand.

"Lee, what do these 'gain' and 'balance' dials do?" I shouted through the plastic.

"Those are for the sound system," she yelled back. "Don't worry about the other stuff. Just push the button that says 'auto' and everything will work fine. But not until the lines are cast off."

After hunting through several different screens of confusing data, I finally found the 'auto' button. And just in time, too, as Lee and our weather strategist were casting off our dock lines. I pushed the button and the two big wings rotated to the proper angles with a smooth and confidence-inspiring electrical whirring sound. The camber adjusted, the twist dialed itself in, the slat retracted and the flap moved. The boat shot into the channel so fast that I didn't need to be reminded to buckle up my five-point harness.

After a few tacks, we were out in the Bay. The wind was a pleasant 12-15, and our boat speed was in the 20s. We touched 30 on what the skipper said — over the intercom — was a hot reach, although my instruments always seemed to show the wind coming from just a few degrees off the bow.

Lee's voice came over the intercom: "Max, when we approach the starting line you might have to feather or even

a joy to be sailing again!

"Where's the windward mark?" I asked over the intercom.

"It's the Harding Rock Wind Tower," Lee informed me. "One of the largest structures on the Bay."

To me it seemed to be poorly placed. I remembered Harding Rock as being a soft spot in the wind and a hot spot in the current. But Lee assured me that the wind aloft was worth capturing. She also assured me that, as long as we stayed outside the ring of stand-off floats, there was no possible way for the rotor blades to touch our rig. Nice to know.

We rounded the windward mark a close second, and then flew downwind, mostly foil-borne, to the leeward mark down on the Berkeley Circle. Our computer managed the puffs properly, and we pulled into a narrow lead. But we hit a patch of light air, and by the time the next puff arrived the number two boat was coming up fast from astern. As we closed on the leeward wind tower, it was not clear if they would get their inside overlap in time.

"Ten lengths, mark room!" my panel flashed at me. It was a text communication from the other boat, now just overlapped to windward and inside.

"Feather!" shouted Lee over the intercom. "We have to bear off to give room."

"I fumbled to find the right button, pushed it hard with maybe six or seven lengths to the mark. But just then the engine died.

"Damned two-strokes," cursed the skipper.

"Switch to manual!" shouted Lee.

"How?" I screamed back, randomly hitting some buttons that I thought might be the override controls. But the screen went all blue and displayed the words "program not responding."

Meanwhile we had bore off as far as we could without capsizing. The windward hull was already way up in the air and, if the wings didn't feather or stall, we'd be over. We were at the mark, and I saw the leeward wing of the inside boat scrape our elevated windward hull. Looking down under our hull I could see that the inside boat had been forced partly



RUF INTERNATIONAL

**'RUF'ing it — The Rapid Urban Flexible Dual Mode Transport System is nearly a reality.**

backwind a little. Make sure you know where the buttons are. They override the automatic trim mode, but only as long as you keep them pressed."

After a little more coaching I was ready, and practiced feathering and backing as we dodged the boats in the divisions that would start after us. A mixed bag of PHRF racers, plus one-design fleets for Antrim 13-meters, Santana 22s and Bear Boats. Then a countdown window appeared on my display, and the skipper announced that the prep signal had been made.

"Got the course?" asked Lee.

"Course tweet received," he confirmed, and he forwarded it to all onboard displays.

Our start was almost dead even with the other boats in our class, not surprising with computers calling the approach on every boat. But our wind strategist had done his homework well, and he had the wind analyzer programmed to match the conditions of the air mass perfectly. A few tacks on semi-predictable shifts and, thanks to fuzzy logic, we were crossing in front of four of our five competitors. The wind was up to the high teens, the trim was on auto, we were screaming to windward with a hull flying, and I was warm and dry watching the dials. What



inside the small stand-off buoys protecting the turbine blades.

Then came the agonizing crack of splintering carbon fiber composite on splintering carbon fiber composite, as the wind turbine blade and the other boat's windward wing sail collided head on.

"Protest!" said my display, which had only taken a couple of seconds to re-boot itself.

But it was the wrong couple of seconds. We were clearly in the wrong, and we withdrew from the race, sailing back to the club at low speed in case the other boat, with one wing broken, needed assistance.

**T**hey never did fool around when it comes to protest hearings at my yacht club, and the tradition persists. An hour later I was in the hearing room. The protest had been properly filed, the facts were clear, and even though we had withdrawn from the race, the RC still had to hold the required liability hearing.

The surprising part was that the

waiver I had signed appeared to make me liable for damages if I should be found to be at fault. And another surprise: Since these cats are an ISAF class, we were all required to follow Olympic Committee rules. That meant that I was technically required to use performance-enhancing drugs for the competition, as are all competitors in all events under IOC jurisdiction. I could be banned from future competition if a finding of drug evasion were to be reported to ISAF.

"What's your estimate of the damage?" I asked the other skipper.

"The wing is at least \$750K," he informed me. "And I just received a text from the power company — \$2.2 million for the turbine blade.

I promptly passed out.

**"M**ax! Pay attention!" said Lee, prodding me in the side.

"That's a ridiculous amount of money!" I stammered.

"What is?" The committee chair replied.

"I think it's reasonable," said the other skipper.

But something was different. The same people were in the room, the same pictures were on the wall and the same trophies were in the display cases. But Lee looked like a student again. And the Protest Committee seemed to be discussing the addition of a new dining room to the clubhouse rather than the cost of replacing carbon wings and turbine blades. What year was it, anyway?

I reached for the copy of *Latitude*, still wedged in the handle of my bag. "January 2010," I said out loud with profound relief.

"Yes we know," said the Commodore impatiently. "It's the latest issue."

"Max fell asleep again during the financial report," said the yacht club treasurer, who had been playing the role of protesting skipper in my dream.

"I move that we approve the financial report" I said. "And I also move that we never allow power sail trim in any race this club sponsors. Ever."

"Second," said the treasurer.

— max ebb

## GET AMERICA'S FINEST BOATING EDUCATION



Location	Phone #	Location	Phone #
Antioch	(925) 377-2628	San Mateo	(650) 592-3604
Marin	(415) 924-2712	Santa Clara	(408) 225-6097
Martinez	(925) 377-2628	Santa Rosa	(707) 793-0538
Monterey Bay	(831) 624-3333	Stockton	(209) 951-3862
Sacramento	(916) 782-1240	Vallejo	(707) 552-6287
San Leandro	(650) 592-3604	Walnut Creek	(925) 377-2628

[www.usps.org/localusps/d25/squadrons](http://www.usps.org/localusps/d25/squadrons)



Society of Accredited  
Marine Surveyors®

Serving Northern California

**Randell Sharpe, AMS®**  
877.337.0706  
rsharpe@sharpesurveying.com

**Tom List, AMS®**  
415.332.5478  
listmarine@yahoo.com

**Rick Whiting, SA**  
415.740.2924  
captain\_rick@sbcglobal.net

**Jack Mackinnon,  
AMS®/SMS**  
510.276.4351  
surveyjack@aol.com

**Jesse Brody, AMS®**  
415.342.0757  
jesse@baymarinesurvey.com

**Francoise Ramsay, AMS®**  
415.497.7409  
framsay@comcast.net

# THE RACING

It's a new year, a new decade and a new edition of The Racing Sheet, which kicks off with a look at a brand new event, the **Paradise Cove Match Race**. Next up is a look at the Cal Maritime Keelhaulers' trip to the **Kennedy Cup**, and another offshore event, the **Clipper 'Round the World Race**. We follow that up with a round-up of the Bay's Midwinters, before heading south for a closer look at **BMW Oracle Racing** before finishing off with some **Race Notes**.

## Paradise Cove Match Race

With such a full racing schedule, just finding a slot to schedule a new event on the Bay is a challenge in and of itself. Add the fact that so many types of events are already on that schedule, and it might seem there isn't much chance for a club with a somewhat nascent racing program to add to its offerings. But that wasn't the case December 4-6 at Tiburon YC. Thanks to the efforts of Kristen and Peter Lane, and Cal Maritime Director of Sailing Charlie Arms-Cartee, the Bay's first open match racing event in ages drew eight teams for the Paradise Cove Match Race.

Cal Maritime and Tiburon YC sailors provided J/22s and US Sailing trained the judges. The result was a typical match race regatta. The only difference was that, as an ISAF Grade 5 event, it was open to anyone.

With early-morning start times, the teams sailed 11 flights for a grand total of 42 races, and by the time the dust had settled, Cal Maritime Dinghy Coach Ty Reed and his crew of 'Keelhauler' sailors won on a countback over Paradise Cove local Shawn Bennett and third-placed John Horsch, whose regular ride — with which he won San Francisco YC's Belvedere Cup match race earlier this year — is the J/105 *Rhymenoceros*.

"Match racing takes all the things we

first of many more match racing events here."

## Kennedy Cup

The Cal Maritime Offshore sailing team went to Annapolis, Maryland and the US Naval Academy November 6-8 and came back with the Kennedy Cup — College Sailing's offshore championship. The Keelhauler's squad of driver Cole Davis, tactician John Gray, trimmers Thor Proulx, Matt Van Rensselear and Tom Steele, plus mastman Sebastien Laleau, pitman Evan Wanamaker, and bowman Kyle Vanderspek put on a clinic for the other eight teams in the nine-race series sailed in Navy 44s.

The team posted five bullets in breeze that ranged from zero to 20-plus knots, showing the kind of skill you can develop by sailing on the Bay year-round, which they do.

"The team has been racing the Academy's 1D48 regularly on the Bay," Arms-Cartee said. "These guys are used to racing together and that made the difference this year."

With competition that included the U.S. Naval Academy, U.S. Coast Guard Academy, Cornell, St. Mary's, the University of Rhode Island, Maine Maritime, U.S. Merchant Marine Academy and Massachusetts Maritime Academy, the field was anything but soft. The fact that our Bay Area team won the Cup is big — by winning the Kennedy Cup, the Cal Maritime sailing team became the ICSA big boat national champions, and earned the right to represent the U.S. at the 2010 Student Yachting World Cup in France next fall!

## Clipper 'Round the World

In the Clipper 'Round the World Race, sole American entry *California* finished 8th in Race Four from Cape Town to Geraldton, Western Australia — a mere seven hours behind

the first-place, now-three-leg winner *Team Finland*. *California* played its "stealth mode" card near the end of the leg, at one point closing to within about 20 miles of the pack.



DANIEL FORESTER/ROLEX

"It was quite an experience," said *California* crewmember Max Spring of San Jose. "We didn't see the big swells we were anticipating but it was challenging, with a confused sea state a lot of the time. Overall I think we were pretty lucky with the weather. I've really enjoyed my Clipper Race experience, from the training, which was really well organized, to representing my home state on *California* on this leg."

While undoubtedly not the result the team was looking for, finishing so close to the rest of the pack after a frustrating first leg and breakdown-ridden leg to Cape Town had to be gratifying. The Bay Area's Charles Willson will be joining the boat and 'round the worlder Quannon Au for Race 5 to Singapore which should be well underway by the time you read this. Meanwhile the organizers have announced that San Francisco will be the stopover in California this year.

## Midwinters Notebook

After a break over the Thanksgiving weekend, midwinter racing got back underway December 5-6 with some really good turnouts at the Golden Gate YC's



**Kennedy Cup winners:** back row from left — John Gray, Cole Davis, Thor Proulx, Thomas Steele, Evan Wanamaker, Sebastien Laleau, Matt Van Rensselear; front row — Kyle Vanderspek.

love about fleet racing and cranks up the volume!" said Kristen Lane. "What's even better is you don't have to own a J/22 to participate. Paradise Cove is a perfect venue for this format. We hope this is the



**Alan Brierty's 'Limit' bashes upwind in the Rolex Trophy Rating Series off Sydney, a prelude to the Sydney Hobart Race which will be in the books by the time you read this. Look for 'Limit' in this year's Pac Cup. Inset — 'Alfa Romeo'.**

Manuel Fagundes Seaweed Soup Series on Saturday, and both the Sausalito YC Mids and the Richmond YC Small Boat Mids.

The Seaweed Soup Series got a bright, sunny . . . and fluky day that saw shortened courses and zero-to-hero moves — and vice-versa — on what, for the larger boats, ended up being a Blackaller-Harding-Ft. Mason and back to Harding for a surprise finish.

The "little guys" at Richmond got a nice and sunny start to their Sunday program, but as the day wore on, it got colder and darker. What it lacked in temperature, it more than made up for in breeze, to the mid-teens depending on where you were on the Bay.

The following weekend, December 12-13, was slated to include the second installment of the RegattaPRO Winter One Design series, Island YC Mids and the Berkeley YC Mids. The weather outside was frightful — cold, breeze-on and ex-

tremely wet — but it didn't stop a few dozen boats from showing up for Berkeley YC's mids over the weekend. Nearly 40 boats — including 10 Express 27s — showed up on Saturday to race in breeze that scratched the mid-20s at times and was accompanied by torrential downpours. Another 20 boats showed up on Sunday — the two days are scored as separate series — and got more of the same with less precipitation.

"The weekend was wild and very wet!" said Berkeley YC's Bobbi Tosse. "There was rain, there was hail, and there was plenty of wind. But it wasn't all cold and miserable; we were also treated to some sunshine and rainbows. Add in spectacular views of all three bridges to the mix and you have a fantastic weekend!"

**'California' bashes upwind in the Clipper 'Round the World Race; San Francisco has been confirmed as the race's West Coast stopover later this year.**



CLIPPER VENTURES

"Not everyone thought going out in this stuff was a very swift idea. On Saturday, only half the fleet showed. The 8-mile course was completed with dispatch, even though there were times that no one could see the marks due to the heavy rain. "D" was the first weather mark and the day was marred with a dismasting. Nathalie Criou's Express 27 *Elise* reportedly tangled with the first buoy, and the only part of the mast left was from the spreaders down. The buoy is a government mark and is frequently referred to as the 'spinnaker eater.' Happily, no one was hurt.

"On Sunday, a little less than half of the 46 entrants made an appearance, and the rest missed out on a fine day. The rain stopped before the start and the wind didn't die completely until almost all the boats had finished. The sun even made an appearance."

Down on the Estuary, the hearty crowd at the Island YC's Island Days series showed en masse, with 17 of the 22 entries showing up on Sunday. Meanwhile, the sailors entered in RegattaPRO's Winter One Design Series chose to dream away a rainy day. PRO Jeff Zarwell said he started getting queries in the middle of the week from entrants wanting to know if the day was still on, so he sent an email to the fleet asking what people's plans were. Over 85% of the fleet responded and the answer was an overwhelming "no," or "I'll go if everyone else does." Faced with the prospect of not having enough boats to constitute divisions, Zarwell pulled the plug.

December 20 was the second installment of the South Beach YC's Island Fever series, and 16 of the 30 entries must have already have done their Christmas shopping in order to make it out on the water for yet another rainy day. You'll find the results for all these on page 126.

# THE RACING



ALL PHOTOS LATITUDE/ROB

December on the Bay, clockwise from top-left — this month's mystery photo is of a new boat, under build in the Bay (we'll have more next month); the Golden Gate YC's Manny Fagundes Seaweed Soup Series turned into a drifter; Angie Rowland trims while Steve Stroub drives his SC 37 'Tiburon' at the Seaweed Soup Series; the Paradise Cove Match Race featured some close action; it also on-the-water judging too; the Bay's Snipe sailors got in gear for the first installment of the Richmond YC Small Boat Midwinters; this 29er is hatin' life behind a pair of Wylie Wabbits; the Byte fleet in a downwind procession.

## America's Cupdate

The entire BMW Oracle Racing Campaign was loaded on a freighter December 15, and is headed for Valencia, as Alinghi's appeal to reinstate Ras Al Khaimah as the venue was denied the same day BMW Oracle Racing shipped out from San Diego. Bay Area IOD sailor Ron Young, who was a prin-

cipal on Tom Blackaller's Golden Gate Challenge in the challenger series for the 1987 America's Cup in Freemantle, Australia, got an up-close look at the BMW Oracle Racing before they packed up for Valencia. Here's his report:

"In late November, I received an invitation no one could turn down to fly to San Diego and check out the new BMW

Oracle Racing trimaran on its last day of testing in San Diego.

"Like all the best Cup efforts there was a noticeable sense of purpose within the 50,000-square-foot, one-story BMW Oracle Racing compound in San Diego. All 90 members in the San Diego portion of the 150-member team seemed to be in a controlled hurry. Berthed in the



just 100 yards from the compound, the trimaran is a stunning vision from a futuristic movie!

"It took 10 minutes to hoist the soft sail predecessor to the wing. By contrast, the wing of is left up overnight and just allowed to rotate on its vertical axis to minimize loading as the wind buffets it. Once off the mooring and wing trimmed, the boat is strikingly fast, usually sailing at two or three times the true wind speed. It flies a hull at around 8 knots of breeze. Since defender *Alinghi*

is believed to fly a hull in as little as 6 knots of true wind speed, crew weight is a strategic consideration. There is discussion of racing with as few as 7 or 8 sailors, including team owner Larry Ellison. If Alinghi succeeds in limiting racing conditions to 15 knots of wind speed or less, skipper Russell Coutts may even skip the ride sometimes, depending on wind strength. Helmsman James Spithill and tactician John Kostecki and trimmers will have multiple responsibilities and require expertise in the care

and operation of reciprocating engines, hydraulic systems, and winches driven by a BMW engine, not grinders and instruments. Since Dennis Conner's 1988 catamaran was sailed by a crew of 9, the trimaran is likely to be sailed by the smallest crew in Cup history.

"With every design change in the Cup, there is a heightened emphasis on engineering. the trimaran's performance metrics and structural loads are collected by 560 input sensor channels from over 100 sensors on the boat and moni-

# THE RACING

tor over 4,000 variables. A Sail Vision system takes over 1,800 photos of the 6,800 square foot wing, the 6,700-sq-ft genoa and the 8,400-sq-ft gennaker daily, for shape analysis. The structural loads throughout the boat are monitored by 125 alarms. The wing rotates and the eight flaps articulate to form the most efficient airfoil; it also cants side to side to improve efficiency and decrease downward loading on the leeward ama. An important element of the hurried sail testing program has been gently working up the loads as the crew learns about the wing and boat in different wind and wave conditions. While methodical sail testing was unbelievably boring in the 12 meter and IACC days, going 2 or 3 times the speed of the wind makes testing aboard *BMW Oracle Racing 90* the best 'sail jail' yet.

"The sound of the engine is decidedly unpleasant; human power is a natural and productive design constraint to Cup performance. Crew members, with all of their personalities and complexities, add to the America's Cup more than the efficiency and drone of even a fine BMW engine.

"The team will have only a month to test, practice and prepare for the show-



RON YOUNG

**One thing you won't see in the team-supplied photos that's evident here, is how much control *BMW Oracle Racing* have over rake. When they unroll the massive gennaker, the center of effort moves so far forward, they have to compensate by raking the wing aft.**

down with Alinghi starting February 8.

"After years of sailing and watching AC boats sail at 8 to 18 knots, it was an exhilarating experience to spend a day

chasing the trimaran off San Diego at 20-30 knots. The boat has already sailed over 40 knots. While I wouldn't have guessed this years ago, I think these two giant, all-out multi-hulls will be good for the Cup this time around. The scale, speed and danger will make this the most telegenic America's Cup ever."

## Race Notes

*Playin' the Piana* — Peninsula-based St. Francis YC member Peter Vessella and his crew of Tracy Usher and John Callahan beat a "who's-who" field at the Piana Cup on Biscayne Bay December 12-13. The first of four events that constitute the Jaguar Cup midwinter series for Etchells, the regatta brought out 45 boats for what had been scheduled to be a two-day regatta. Going into the second day, Vessella's team led by three points after scoring a consistent 3-2-3 on Saturday; when the breeze never filled and racing was abandoned after a 2.5-hour postponement, the title was theirs.

*Sign Up Time* — It's the heart of the midwinter sailing season, but it's not too early to sign up for YRA racing for this year. We've included the **YRA sign-up**

Big midwinter race turnouts around the Bay so far have been rewarded with awesome conditions, but we don't have the time or manpower to chase down all the results. Please post them on your club's website or send them directly to the Racing Editor at [rob@latitude38.com](mailto:rob@latitude38.com). Our format, to these many years, is to include the name of the boat, the type and length of boat, and the first and last names of the owner(s). Please do your best to get us that info, and we'll do our best to get that info into *Latitude 38* and *Lectronic Latitude*.

### GOLDEN GATE YC MANNY FAGUNDES SEA-WEED SOUP SERIES #2(12/5, 1r)

PHRF 1 (PHRF ≤ 50) — 1) **Javelin**, SC 37, Pat Nolan; 2) **Sapphire**, Synergy 1000, Dave Rasmussen; 3) **Racer X**, Farr 36, Gary Redelberger. (14 boats)

PHRF 2 (PHRF 51-99) — 1) **Q**, Schumacher 40, Glenn Isaacson; 2) **Outsider**, Azzura 310, Greg Nelsen; 3) **Encore**, Sydney 36, Dan Woolery. (16 boats)

PHRF 3 (PHRF 100-129) — 1) **El Raton**, Express 27, Ray Lotto; 2) **Uno-129**, Wyliecat 30, Steve Wonner; 3) **Shaman**, Cal 40, Steve Waterloo. (14 boats)

PHRF 4 (PHRF 130+) — 1) **La Paloma**, IOD, James Hennefer; 2) **Arcadia**, Modernized Santana 27, Gordie Nash; 3) **Torrid**, Aphrodite 101, Larry Westland. (9 boats)

## THE BOX SCORES

CATALINA 34 — 1) **Casino**, Bill Eddy; 2) **Queimada**, David Sanner; 3) **Sea Spirit**, Laurence Baskin & Herbert Bros. (9 boats)

KNARR — 1) **Flyer**, Chris Kelly; 2) **Pegasus**, Peter Noonan; 3) **Knarr 134**, J. Eric Gray. (5 boats)

FOLKBOAT — 1) **Polperro**, Peter Jeal; 2) **Freja**, Tom Reed; 3) **Frihed**, William Madison. (7 boats)  
Complete results at: [www.ggyc.com](http://www.ggyc.com)

### SAUSALITO YC MIDWINTER #2(12/11, 1r)

DIVISION A (SPINNAKER) — 2) **Razzberries**, Olson 34, Bruce Nesbitt; 1) **Gammon**, Tartan 10, Jeff Hutter; 3) **Breeze**, J/105, Franci Fridell. (13 boats)

DIVISION C — 1) **Q**, Schumacher 40, Glenn Isaacson; 2) **Grey Ghost**, Hanse 342, Doug Grant; 3) **Min Flicka**, Hanse 37, Magnus Le Vicki. (7 boats)

DIVISION D — 1) **French Kiss**, Beneteau 350, Dave Borton; 2) **Mimicat**, Hinckley 38, Robert Long; 3) **La Mer**, Newport 30, Randy Grenier. (5 boats)

DIVISION E — 1) **Tackful**, Santana 22, Frank Lawler/Cathy Sterhoff; 2) **Kelly Shawn**, Santana 22, Leah Pepe; 3) **Aquila**, Santana 22, Derek Meyer. (3 boats)  
Complete results at: [www.syconline.org](http://www.syconline.org)

### ISLAND YC ISLAND DAYS MIDWINTERS #2 (12/13, 1r)

DIVISION A (PHRF ≤ 138) — 1) **Rascal**, Wilderness 30, Rui Luis; 2) **Crinan II**, Wyliecat 30, Bill

West; 3) **Audacious**, J/29, Scott Christensen. (3 boats)

DIVISION B (PHRF 168) — 1) **Bewitched**, Merit 25, Laraine Salmon; 2) **Dire Straits**, J/24, Steve Bayles; 3) **My Tahoe Too**, Capri 25, Steve Douglass. (4 boats)

DIVISION C (PHRF 139-180) — 1) **Crazy Eights**, Moore 24, Aaron Lee; 2) **Lelo Too**, Tartan 30, Emile Carles; 3) **Galatea**, Aphrodite 101, Ken Viaggi. (4 boats)

DIVISION D (PHRF 181+) — 1) **Wings**, Columbia 5.5 Meter, Mike Jackson; 2) **Spitfire**, Santana 22, Tom McIntyre; 3) **Tinker**, Wilderness 21, Matthew Beal. (6 boats)

DIVISION E (NON-SPINNAKER) — 1) **Scrimshaw**, Alerion Express 28, Michael Maurier; 2) **Freudian Sloop**, Islander 30-II, Steve Taylor; 3) **Take 5**, Wilderness 21, Roger England. (4 boats)  
Complete results at: [www.iyc.org](http://www.iyc.org)

### RICHMOND YC SMALL BOAT MIDWINTERS #1 (12/8, 3r/0t)

EL TORO SR. — 1) Will Paxton; 2) Michael Quinn; 3) Gordie Nash. (13 boats)

EL TORO JR. — 1) Michael Pacholski; 2) Wilson Fletcher; 3) Haydon Stapleton. (12 boats)

OPTI — 1) Jack Barton; 2) Will Cefali; 3) Kyle Larsen. (29 boats)

SNIPE — 1) Tom O'Neill; 2) Vince Casalaina; 3) Dick Loomis. (6 boats)

SOUTHAMPTON OPEN — 1) Pieter Versavel; 2) Del Olsen; 3) Gill Woolley. (7 boats)

BYTE — 1) Trish Sudell; 2) Laurie Davis; 3) Mi-

form in this month's issue; you'll find it on pages 128-129. Also make sure not to miss the **2010 Northern California Racing Calendar and YRA Master Schedule**, which should be available from most places you pick your copy of *Latitude 38*, or at our World Headquarters in Mill Valley after January 1. It's also available as a PDF at [www.latitude38.com](http://www.latitude38.com).

**Coach of the Year** — Tiburon's Mark Ivey was recognized as **US Sailing's 2009 National Coach of the Year**. At the '09 Star Worlds in Varberg, Sweden, Ivey coached Californians George Szabo and Rick Peters to their first gold star.

Szabo and Peters were also named **US Sailing Team AlphaGraphics Olympic Team of the Year**.

**The Short List** — US Sailing announced the short list for the 2009 Rolex **U.S. Sailing Yachtsman and Woman of the Year** last month. On the Women's side, Redwood City's Molly O'Bryan Vandemoer and Tiburon's Genny Tulloch have both made the list. Szabo is on it and so is Southern Californian Mike Martin — winner of the '09 505 Worlds on the Bay.

*Don't put it off . . . any longer* — You

may remember that in last month's issue, we reported that the **'10 Pacific Cup** was already up to about 60 entries. We know of at least five more boats that haven't yet signed up that should be on the starting line this summer.

The Pacific Cup YC has instituted a new trophy for the highest placing boat — on corrected time — that sails in "cruising configuration." The idea is to lower the bar a little for cruising boats that want to be in the hunt for a trophy without adding a racing inventory and without having to replace their roller furling and dodger.

"Cruising configuration" is defined as: no more than two headsails other than required heavy air or storm jibs that



RON YOUNG

*Another thing you'll see here is the amount of they can cant their wingmast.*

must be on roller furling, and no more than two spinnakers which are required to be tacked on centerline or to a fixed bowsprit. Boats must also have a dodger or pilothouse. The new requirement is aimed at owners of boats like Beneteaus and Catalinas in the 38- to 50-ft size range that aren't geared up for serious ocean racing.

chele Logan. (5 boats)

WYLIE WABBIT — 1) **Weckless**, Tim Russell; 2) **Mr. McGregor**, Kim Desenberg/John Groen/Terry White; 3) **Keala**, Ron Tostenson. (6 boats)

29ER — 1) Finn Nilsen; 2) Annie Schmidt; 3) Chris Ford. (11 boats)

LASER — 1) Drake Jensen; 2) Mike Bishop; 3) Nick Burke. (17 boats)

BREAKWATER OPEN — 1) John Barrere; 2) Steve Lowry; 3) Steve Cameron. (8 boats)

THISTLE — 1) Kristofer Vogelsong; 2) Michael Gillum; 3) David Rumbaugh. (4 boats)

LIGHTNING — 1) Wayne Clough; 2) Mike Molina; 3) Lindsey Watters. (3 boats)

FD — 1) Buzz Ballenger; 2) Zhenya Kiruëshkin-Stepanoff; 3) Jason Lawrence. (3 boats)

WETA — 1) Dave Berntsen; 2) Tim Tsao. (2 boats)

MULTIHULL — 1) George Pedrick; 2) Jason Moore; 3) Nico Columb. (3 boats)

#### BERKELEY YC MIDWINTERS SATURDAY SERIES (12/12, 1r)

DIVISION A (PHRF < 78) — 1) **Stewball**, Express 37, Bob Harford; 2) **Jeannette**, Frers 40, Henry King; 3) **Advantage 3**, J/105, Pat Benedict. (8 boats)

OLSON 30 — 1) **Hoot**, Andrew Macfie; 2) **Voodoo Child**, Charles Barry; 3) **Wraith**, Ray Wilson. (3 boats)

DIVISION B (PHRF 81-105) — 1) **Mintaka 4**, Farr 38m, Gerry Brown; 2) **Sheeba**, C&C 99, Michael Quinn; 3) **Flexi Flyer**, Soverel 33, Mitchell Wells. (5 boats)

EXPRESS 27 — 1) **Moxie**, Jason Crowson;

2) **El Raton**, Ray Lotto; 3) **Motorcycle Irene**, Will Paxton/Mark Jones. (10 boats)

ULTIMATE 20 — 1) **Breakaway**, John Wolfe. (1 boat)

DIVISION C (PHRF 108-168) — 1) **Maguro**, S 35, Jack Feller; 2) **Phantom**, J/24, John Guilford; 3) **Frogflips**, J/24, Richard Stockdale. (3 boats)

DIVISION D (PHRF 171-198) — 1) **Achates**, Newport 30, Robert Shock; 2) **Lelo Too**, Tartan 30, Emile Carles; 3) **Starkite**, Catalina 30, Laurie Miller. (3 boats)

DIVISION E (PHRF 201+) — 1) **Can O' Whoopass**, Cal 20, Robert Shock; 2) **Fjording**, Cal 20, Tina Lundh. (3 boats, 1 DSQ boat)

Complete results at: [www.berkeleyyc.org](http://www.berkeleyyc.org)

#### BERKELEY YC MIDWINTERS SUNDAY SERIES (12/13, 1r)

DIVISION 1 (PHRF < 99) — 1) **Sweet Okole**, Farr 36, Dean Treadway; 2) **Warp Speed**, C&C 115, Jeff Smith; 3) **Flexi Flyer**, Soverel 33, Mitchell Wells. (6 boats)

OLSON 30 — 1) **Hoot**, Andrew Macfie; 2) **Voodoo Child**, Charles Barry; 3) **Corsair**, Don Newman. (3 boats)

EXPRESS 27 — 1) **Tule Fog**, Steve Carroll; 2) **Great White**, J.P. Sirey duBuc de Ferret; 3) **Dianne**, Steve Katzman. (5 boats)

ULTIMATE 20 — 1) **Breakaway**, John Wolfe. (1 boat)

DIVISION 2 (PHRF 102-177) — 1) **Gruntled**, Moore 24, Simon Winer; 2) **Iwishwasawabbit**, Moore 24, Pete Rowland; 3) **Frogflips**, J/24 Richard Stockdale. (3 boats)

DIVISION 3 (PHRF 180+) — 1) **Antares**, Is-

lander 30-2, Larry Telford; 2) **Kodiak**, Bear, Peter Miller. (2 boats)

CATALINA 22 — (0 boats)

Complete results at: [www.berkeleyyc.org](http://www.berkeleyyc.org)

#### SOUTH BEACH YC ISLAND FEVER SERIES #2 (12/20)

PHRF ≤ 146 — 1) **Centomiglia**, Flying Tiger, 10M, Fabio Maino; 2) **Sierra II**, Sabre 362, Paul Eisenhardt; 3) **Breakout**, Santana 35, Ritchey/Powell. (5 boats)

PHRF 147+ EXCEPT 180 — 1) **Eyrie**, Hawkfarm, Synthia Petroika/Sylvia Earle; 2) **Double Play**, Yankee 30, RDK Partners. (3 boats, 2 finishers)

PHRF 180 — 1) **Huge**, Catalina 30, Bill Woodruff; 2) **Missy B**, Catalina 30, Russell Calvery; 3) **Goose**, Catalina 30, M&L Kastrop. (4 boats)

NON-SPINNAKER — 1) **Seaview**, C&C 115, Pete Hamm; 2) **Fancy**, Ericson 33, Chips Conlon. (3 boats, 2 finishers)

Complete results at: [www.southbeachyc.org](http://www.southbeachyc.org)

#### SEQUOIA YC WINTER SERIES #2 (12/5)

SPINNAKER — 1) **Head Rush**, Antrim 27, Charlie Watt; 2) **Sail La Vie**, Ericson 35-2, Phil MacFarlane; 3) **Lucky Duck**, Wylie 34, Paul McCarthy. (13 boats)

NON-SPINNAKER — 1) **Linda Carol**, Catalina 320, Ray Collier; 2) **Iowa**, Hunter 380, Rick Dalton. (3 boats, 2 finishers)

Complete results at: [www.sequoiayc.org](http://www.sequoiayc.org)

# SIGN UP FOR THE 2010 RACING SEASON

Entry Form  
next page!



## Welcome to YRA Racing, the best racing value on the bay!

Thank you for participating in the YRA! We offer a choice for racing both on the Bay and on the local ocean!

### RACING INFORMATION

#### **HDA (Handicapped Divisions Association) & ODCA (One Design Class Association)**

- Round the Buoy racing for boats with a current NCPHRF rating certificate (HDA) or for One-Design classes belonging to ODCA. The Vallejo, 2<sup>nd</sup> Half Opener, and Season Closer Regatta's (The Party Circuit Series) are included in the HDA & ODCA Season Racing fees.
- The complete season consists of 6 Round the Buoy races- the Spring 1,2, & 3 and the Fall 1, 2, & 3, as well as the Party Circuit Weekends- Vallejo, the 2<sup>nd</sup> Half Opener, and Season Closer Regatta's. Boats may not be in the same division for the Party Circuit & HDA/ODCA Series.
- HDA Divisions are determined by grouping similarly rated boats.
- HDA divisions are invited to race in the Crewed Lightship 1 race for an additional \$5.00 per racer. A signed Minimum Equipment List must be included with entry. Entry into the Crewed Lightship 1 race must be made at the time of season entry or individual race fees will apply.
- If you are not sure if your One-Design fleet is a current ODCA fleet, or would like to sign your fleet up for ODCA, please contact the YRA office at (415) 771-9500 or [info@yra.org](mailto:info@yra.org).

#### **OYRA (Offshore Yacht Racing Association)**

- Approximately 12 ocean races ranging from 15 to 51 nautical miles in length
- OYRA racers are invited to race in the Vallejo race for an additional \$5.00 per racer or in the entire Party Circuit series for \$25. Entry into the Vallejo race or Party Circuit must be made at the time of season entry or individual race fees will apply.
- Racers will race in one of the following 5 divisions, determined by their boats D/L ratio (unless choosing to race in the SHS division):
  - PHRO 1a – NCPHRF of 0 or less
  - PHRO 1 - D/W ratio Less than 100
  - PHRO 2 - D/W ratio 100 to 199
  - PHRO 3 – D/W ratio 200 & Over
  - SHS – Shorthanded division, Specifically Requested

#### **WBRA (Wooden Boat Racing Association)**

- The WBRA is a Golden Anchor member in US Sailing and includes US Sailing membership dues in its entry fee
- Bay racing for one of the following 4 fleets:
  - Bird Boats
  - Folkboats
  - IODs
  - Knarrs

#### **The YRA Party Circuit Series**

- This series highlights the marquee YRA events: The YRA Season Opener (The Great Vallejo Race) in May, the YRA 2<sup>nd</sup> Half Opener in July, and the YRA Season Closer in September. Three fun-filled weekend events with great parties on each Saturday night!
- There is one throw out race for the series. In addition, 50% of the fleet or class must qualify for awards to be given.
- Divisions available for PHRF racers, One-Design Classes, Double/Singlehanded racers and Non-Spinnaker boats. If your One-Design Fleet is interested in signing up, please contact the YRA office.

### GENERAL INFORMATION

- **YRA Sailing Instructions are available on the YRA website at [www.yra.org](http://www.yra.org)**, or at the YRA office. Sailing instructions are normally posted approximately 2 weeks prior to the race for each series. If you do not have access to the internet and need to have your race instructions mailed to you, please contact the YRA office at (415) 771-9500 or [info@yra.org](mailto:info@yra.org)
- Entries for a series, or individual regatta, must be received by 8 am the Monday before the race is scheduled or a \$35 late fee will be applied. No entries will be accepted after 5 pm the Wednesday before a race is scheduled.
- **A YRA sailing membership and a membership in a YRA member yacht club is required to register a boat for any YRA series.** A YRA membership is required to race in any individual YRA Race, but one time racers do not need to belong to a member club.
- Sailors entering the OYRA Season, or any individual OYRA Race, must complete an OYRA Minimum Equipment List and submit it to the YRA office no later than 5 pm the Wednesday before their first ocean race. The MEL is valid for the entire OYRA season, unless changes are made to the boat, in which case a Skipper must re-submit a valid MEL. **Please note that to race in an OYRA Race a 406 EPIRB is required.** A Boat/Crew Information sheet must also be submitted by 5pm the Thursday before each ocean race.
- Please fill out your entry form completely, sign, date and return it to the YRA office along with your payment. If you need additional assistance completing this form, please contact the YRA office.
- You can save time and postage by signing up online! Visit [www.yra.org](http://www.yra.org) for more information!





# Yacht Racing Association of San Francisco Bay - 2010 Entry Form

Quarters 35 S, Fort Mason  
San Francisco, CA 94123  
Phone: 415.771.9500  
Fax: 415.276.2378  
email: info@yra.org

Name: \_\_\_\_\_ Boat Name: \_\_\_\_\_ Sail Number: \_\_\_\_\_  
 Street: \_\_\_\_\_ Boat Model: \_\_\_\_\_  
 City, State, Zip: \_\_\_\_\_ Manufacturer: \_\_\_\_\_ Yr Built: \_\_\_\_\_  
 Evening Phone: \_\_\_\_\_ Daytime Phone: \_\_\_\_\_ Designer: \_\_\_\_\_ Yr. Designed: \_\_\_\_\_  
 Email Address: \_\_\_\_\_ U.S. Sailing #: \_\_\_\_\_ YRA Member #: \_\_\_\_\_  
 Yacht Club Affiliation: \_\_\_\_\_ Marina: \_\_\_\_\_ Berth/Slip #: \_\_\_\_\_

**Membership Fees:** YRA Membership: *Required for YRA Racing* \$45 \$ \_\_\_\_\_  
**NCPHRF Fees:** Renewal of 2009 Certificate: \$30 for YRA Members/\$40 for NON-YRA Members \$ \_\_\_\_\_  
 New Certificate/Renewal of 2008 or prior Cert.: \$45 for YRA Members/\$55 for NON YRA Members \$ \_\_\_\_\_

Season Racing Fees:	US Sailing Members	Non US Sailing Members	Fleet	See back for more fleet information
Handicap Division Association (HDA) Season (Includes PC races)	\$180	\$195	_____	\$ _____
One Design Class Association (ODCA) Season (Includes PC races)	\$180	\$195	_____	\$ _____
Ocean Yacht Racing Association (OYRA) Season *	\$195	\$210	_____	\$ _____
Wooden Boat Racing Association (WBRA) Season (includes US Sailing Membership)	\$190	N/A	_____	\$ _____
YRA Party Circuit 3 race weekends only: Vallejo, 2nd Half Opener Season Closer	\$150	\$165	_____	\$ _____

Single Race Fees:	US Sailing Members	Non US Sailing Members	Fleet	See back for more fleet information
HDA season racers entering Lightship 1 *	\$5	\$10	_____	\$ _____
OYRA season racers entering Party Circuit	\$25	\$35	_____	\$ _____
OYRA season racers entering just Vallejo	\$5	\$10	_____	\$ _____
Party Circuit racers entering the Summer Sailstice	\$5	\$10	_____	\$ _____
Vallejo Race Only (YRA Season Opener)	\$75	\$80	_____	\$ _____
2nd Half Opener Only	\$75	\$80	_____	\$ _____
Season Closer Only	\$75	\$80	_____	\$ _____
All other YRA Races (write in race name): _____	\$50	\$55	_____	\$ _____

**Late Fee:** *No entries are accepted after 5pm the Wednesday before the race*  
 Any entry Rec'd after 8am the Mon before the race \$35 \$ \_\_\_\_\_

\* All Racers entering an ocean race or ocean series must submit a signed OYRA Minimum Equipment Requirement List. See [http://www.yra.org/OYRA/ocean\\_safety.html](http://www.yra.org/OYRA/ocean_safety.html) or contact the YRA office for more info. **TOTAL** \_\_\_\_\_

In consideration of being admitted to sailing membership in the Yacht Racing Association of San Francisco Bay (YRA), I agree to abide by "The Racing Rules of Sailing" and the Sailing Instructions of the YRA and the regatta sponsors. I warrant that I will maintain compliance with the YRA Minimum Equipment requirements. To the fullest extent permitted by law, I hereby waive any rights I may have to sue the YRA with respect to personal injury or property damage suffered by myself or my crew as a result of our participation in the YRA and hereby release the YRA and it's race organizers from any liability for such injury or damage.. I further warrant that I have not relied upon any of the above entities or individuals in preparing my yacht for racing.

Signed: \_\_\_\_\_ Date: \_\_\_\_\_

Make check payable to YRA. To pay by MasterCard or Visa please provide card info below, including billing street address and zip code

Card Number: \_\_\_\_\_ Exp Date: \_\_\_\_\_ CV # \_\_\_\_\_ Name on Card: \_\_\_\_\_  
 Card Holder's Signature: \_\_\_\_\_ Billing Address: \_\_\_\_\_

**Office use only**

C.C. Check Number \_\_\_\_\_ Amount PD \_\_\_\_\_ DATE Received in office \_\_\_\_\_



# WORLD

We'll depart from our regular format this month and devote this entire section to **Chartering in Washington State and British Columbia.**

## Northwest Wonderland: The San Juans, Gulfs and Beyond

Within the whole of the U.S. and Canada there is arguably no area more ideally suited to vacations under sail than what we like to call the Greater Puget Sound. That is, the islands and coastal regions between Seattle and British Columbia's Desolation Sound. With the promise of easy sailing conditions, line-of-sight navigation, dozens of unspoiled marine parks, and plenty of friendly towns to shop, dine and re-provision in, this vast area should be near the top of every charter junkie's must-do list.

Although some diehards sail year-round up north, the prime chartering season runs from May through September, which is precisely why we're discussing it now. With its relatively short season, and relatively small fleet of charter yachts — at least in comparison to places like the Caribbean and Med — right now is the ideal time to lock in a reservation on the boat of your choice.

We've sailed the pristine waters of the American San Juan Islands and the Canadian Gulf Islands, as well as the primeval fiords of Desolation Sound, and we had a grand time on each cruise. But we certainly don't consider ourselves to be experts on the region. So we solicited tips and comments on favorite places from *Latitude* readers, and received a boatload of insightful info that we'll share with you in these pages.

As you'll learn, the region offers ac-

**The water was so clear and the crabs were so plentiful at this public dock that Karen and her kids decided to fish for them.**



TIM STAPLETON

tivities for sailors of all ages, including hiking, beachcombing, kayaking, fishing, crabbing and swimming — believe it or not, there are areas where the water temperature gets to a pleasant 70°. Another plus, is the likelihood of observing wildlife such as bald eagles and orcas during your cruise. Because these cruising grounds lie between latitudes 47° and 51°N, the sun doesn't set during mid-summer until around 10 p.m., giving you more 'play time' than in just about any other prime sailing venue in the world.

Although you do need to plan your movements and choose your anchorages with the substantial tides and currents in mind, piloting through these waters is easy enough for first-time charterers, as hazards are very well marked on both sides of the border. You are allowed to take American-flagged boats into Canada (and vice versa), by the way. Just be sure every crew member brings a valid passport. With that introduction, we'll turn you over to our readers (whose comments have been excerpted):

"The area is very beautiful, with lots and lots of trees and snow-capped mountains. The shrimp in Desolation Sound are to die for, and are pretty easy to trap. Friends and family can join you almost anywhere by seaplane — very cool!

"The salmon fishing is up and down. Having a guide really helps."

— *pete wolcott  
kiapa, M&M 52*

"Brenda and I bravely gave up boat ownership many years ago and took up bareboat chartering as a means of seeing the world. We've chartered in the Pacific Northwest many times — beautiful areas and many adventures we'll keep for life memories.

"Places we like are (all great an-



TIM STAPLETON

chorages or marinas): Sucia Island (hiking); Roche Harbor (hiking, food); Deer Harbor (ambience, food, walking); God's Pocket (advanced scuba); and Inati Cove, across from Bellingham, WA (just plain beautiful).

— *gary & brenda ouwerkerk  
los osos, ca*

"Despite being avid sailors, our family chartered a power boat, which was a great call. We covered over 400 nm in only one week.

"Prevost had several finger bays with excellent protection, beautiful scenery and quaint homes and cabins. In late June the sun sets right down the bay at 10 p.m. It was 90+° into the night.

"The famous Butchart Gardens had free moorings — we spent two nights — with a dinghy dock and a separate entrance into the gardens. Our tickets allowed us in/out privileges, so we were able to experience the gardens in all the different lighting — morning, afternoon and night. We also took a bus from there down to Victoria and spent a day taking in the Natural History Museum and lunch in a proper pub.

# OF CHARTERING



LATITUDE / ANDY

**Spread: Gliding along on a gentle breeze over flat water, with majestic Mt. Baker as a backdrop — it just doesn't get much sweeter. Inset: Haydon makes a friend.**

"Sidney Spit is a small island that is a marine park. (Think Angel Island, but smaller). It has free docking/mooring and a sandy spit that goes for miles. We hit it one morning at an extreme minus tide. We spent hours walking the spit finding all kinds of treasures such as crab pots, crabs, and sand dollars. There were lots of birds, gulls, egrets, bald eagles, all enjoying a feast — a real adventure."

— tim stapleton  
ypso, cal 2-27

"We chartered three times in Desolation Sound — once as a honeymoon. We tied off to a log at Teakearne Arm one afternoon, had a great bonfire with fresh oysters on the beach, and woke up the next morning to find the mooring log floating and the beach a figment of our imagination. Tides of up to 25 feet, and tying stern lines to trees ashore after anchoring in 90' of water were new experiences.

"The lakes were warm enough for swimming; the waterfalls exciting for showers; the eagles and snow-covered peaks in the channels were breathtaking; picking oysters while lounging in the dink was wonderful.

"Desolation Sound is pristine wilderness with soul-filling beauty. We plan to go up the coast this spring on I'O and spend the summer there."  
— bobbie & robert  
kuschel  
I'O, davidson 44

"Many of our best times in the San Juans and the Gulf Islands have been after Labor Day in September and into October. Yes, the weather is cooler and the possibility of rain is real, but the boat traffic is nearly gone



LATITUDE / ANDY

and it is always easy to find one of the wonderful state or provincial moorings. In September many of the marinas are still operational, but by mid-October the less protected ones will have pulled their floats out for the winter and closed up.

"Victoria Harbour is a special treat. By September it is usually possible to get one of the slips directly in front of the Empress Hotel. Not a bad place to be stuck in the fog. Great for high tea in the afternoon. Not to be missed in Victoria is the Provincial Museum that fronts the harbor, which has tremendous coverage of the native American cultures of the Northwest, and the age of discovery by Europeans.

"During crab season the Dungeness crabs are fabulous. They are catchable in many of the anchorages and with local knowledge in any shallow grassy bottom. Ask your charter company for the latest advice. There is no better dinner than a couple of dungeys straight out of the water and into the pot, accompanied by a nice local artisanal bread and a good Northwest wine!"

— chris & heather stockard  
legacy, saga 43

"I really enjoyed life up there — super easy cruising. There's very clean water and beaches, the weather was great, and there's tons of conveniences. You can see a lot in a week.

"The weather is much better than most people expect. I am a meteorolo-

**By Northwest standards, Friday Harbor is a bustling little town. Shops, restaurants and a top notch marina make it a popular stop.**

# WORLD

gist, and can tell you that the Olympic Mountains shadow the San Juans very nicely. South Whidbey Island, for example, gets about as much precip as San Jose. In Canadian waters you aren't so lucky, as the rainy season extends well into June some years. By mid-July, fog can be a real problem but is not as persistent as along the California coast. There are very few surprises in the summer months and the marine forecasts from the National Weather Service are much, much better than down here.

"Everyone talks about the tides up there, but there really are only a handful of places that you have to be careful of. If you sail on S.F. Bay, it is pretty much the same amount of current in much of the Sound. Tide tables are spot on.

"You'll also hear a lot of griping about no wind. That can be true, especially in late July through August when high pressure tends to dominate, and you end up playing in the land breeze or sea breeze. Otherwise, we found plenty of wind all the way through early July. The distances between very comfortable anchorages are so short, that nursing the boat along in the zephyrs is not a big deal. If possible, see if you can get a drifter or asymmetrical for your charter boat.

— *nick o'kelly*  
either way, *freedom 33*

"We haven't been everywhere in the world, but so far British Columbia is

***A lovely city with a decidedly British feel, Victoria is well worth a visit. The ornate Parliament building lies adjacent to the harbor.***



LATITUDE / ANDY

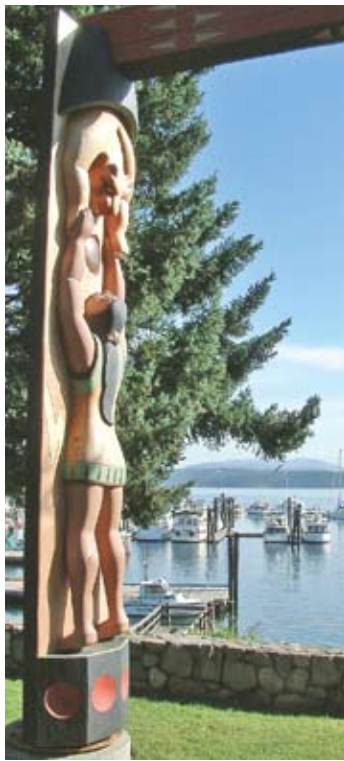

LATITUDE / ANDY



SHIRLEE SMITH



TIM STAPLETON



LATITUDE / ANDY

high on our list of favorite places.

"The town of Ganges reminded us a bit of little towns we've driven through in western Marin County. It's the commercial center for the summer homes in the surrounding forests and hills. It's very cute and a little high-end, but

there are plenty of colorful and less prosperous people around too. The anchorage there is quite large, and the ferry stops somewhere else on the island, so you don't have to contend with it. Seaplanes land along the edge of the anchorage, though, so be sure to stay clear of them. An open wireless Internet hotspot served us well in the an-

***Clockwise from upper left: A contemporary totem pole at Friday Harbor; the approach to False Creek; Madi eyes a shrimp; a Desolation Sound fiord; orcas are commonly seen in the straits; (center) Tim and Karen take a sunset cruise***

chorage in May '07.

"The town has a huge grocery store and lots of smaller shops and restaurants. If you don't want to anchor out, the public marina charges reasonable rates. We bought crab from a local fisherman since we didn't have our Canadian license yet, but I'm sure there are crab in the anchorage for the taking.

"The False Creek anchorage in Vancouver does require a free permit, which limits you to 14 days out of 30. Water taxis provide service from Granville Island and other commercial centers around the cove.

"From False Creek you can explore all of Vancouver. Get a day pass for the transit system and ride the bus, ferry and SkyTrain (BART-equivalent), all on the same ticket. We used our pass to visit the Vancouver Aquarium and ride the ferry to North Vancouver. In the opposite direction we recommend the Mu-

# OF CHARTERING



PETE & SUE WOLCOTT



PETE & SUE WOLCOTT

seum of Archeology at the University of Vancouver. The public market at Granville Island is amazing. It's huge and all under cover.

## Principal Pac NW Charter Firms

- **ABC Yacht Charters**, Anacortes, WA  
800-426-2313 • [www.abcyachtcharters.com](http://www.abcyachtcharters.com)
- **Anacortes Yacht Charters**, Anacortes, WA  
360-293-4555 • [www.ayc.com](http://www.ayc.com)
- **Bellhaven Yacht Charters**, Bellingham, WA  
800-542-8812 • [www.bellhaven.net](http://www.bellhaven.net)
- **Desolation Sound Yacht Charters**, Comax, BC • 877-647-3815 •  
[www.desolationssoundyachtcharters.com](http://www.desolationssoundyachtcharters.com)
- **Great Bear Charters**, Port Hadlock, WA  
360-344-4234 • [www.greatbearcharters.com](http://www.greatbearcharters.com)
- **Infinity Yacht Charters**, Vancouver, BC  
800-664-6049 • [www.infinityyachts.com](http://www.infinityyachts.com)
- **Par Yacht Charters**, Bellingham WA  
360-752-5754 • [www.paryachtcharters.com](http://www.paryachtcharters.com)
- **San Juan Sailing**, Bellingham WA  
360-671-4300 • [www.sanjuansailing.com](http://www.sanjuansailing.com)
- **Sail Northwest**, Seattle, WA  
877-213-7441 • [www.sailnorthwest.com](http://www.sailnorthwest.com)
- **Sail2Discover**, Seattle, WA  
206-794-8539 • <http://sail2discover.com>
- **Windworks Sailing**, Seattle, WA  
206-438-4686 • [www.windworkssailing.com](http://www.windworkssailing.com)

"Gorge Harbour is beautiful, almost like a lake. The entrance is through a narrow gorge with pictographs on the cliff. Otherwise, it's completely surrounded by land, and you can see the distant snow-covered mountains over the trees of the island. There is a marina here, Gorge Harbour Marina Resort, and a very good restaurant, but there aren't many houses, so it feels remote. We caught crabs right off the boat at the dock. Going ashore felt like being in the mountains at a lake.

"You can get Canadian fishing licenses online. In fact, they're difficult to find otherwise. Consider chartering a motor yacht. Wind is often light and variable here, especially in the high season."

— *shirlee smith*  
solstice, *sceptre 41*

"I've only chartered up there once, in April '07, to coincide with the kids' spring break. Although we had no rain until the last morning of our week-long charter, it was pretty cool.

"Two favorites in the San Juan Islands are the Washington State Parks, especially Spencer Spit (beach combing) and Stuart Island (woody hiking); and lastly, just the time spent away from daily life to get out on the water and cope with the tides and weather in order to plan the daily routes from anchorage to anchorage.

"If you have the choice, charter in late June to early July and visit Victoria for Canada Day (July 1), then slip over to Friday or Roche Harbor for the 4th of July. You'll see two fireworks shows, and the wind is usually better. August is typically fairly calm up there."

— *brian timpe*  
pearl, *gulf 29*

"I'm a long-time *Latitude 38* reader who moved to Vancouver, BC in '04. Since then, I've experienced some amazing cruising up here.

"Vancouver Island acts as a humongous breakwater. With only 22 miles of fetch between Vancou-

ver Island and the mainland, we don't see ocean swells, although northerly wind conditions can create some nasty short chop.

"Of the Gulf Islands, The Pender Islands have a plethora of anchorages which rarely fill up — Port Browning is a favorite and has a dock with easy access to the Port Washington Bar and Grill, as well as local markets.

"Farther up the Gulf Island chain, Salt Spring is a large island with a lot to offer in terms of shoreside attractions — restaurants, art galleries and festivals — all summer long.

"On the mainland side, the Sunshine Coast is named due to its having more sunny days than most anywhere else in the Pacific Northwest. Gibsons is a usual first stop, and is a pleasant, artsy town that feels oddly like Sausalito. Farther up the coast, boaters have numerous ports of call available at Pender Harbour, Secret Cove, Smuggler's Cove, and Sechelt."

— *ben jones*  
vancouver, *bc*

"I now sail SF Bay, but I grew up on Puget Sound. The charter companies all do a good job of pointing out danger areas, but every year a few skippers manage to ground their boats. The San Juans are well charted, so if you pay attention to the charts and plan your course conservatively you should stay out of harms way. Most of the waterways in the San Juans are actually very deep compared to SF Bay.

"My favorite time in the San Juans

***They don't take reservations for slips in front of the stately Empress Hotel. So just show up about 9 a.m. and hope for an opening.***



LATITUDE / ANDY

# WORLD OF CHARTERING

is mid- to late September. The days are still long, the crowds are down, the charter companies offer better rates, and the weather is usually outstanding — I think the very best of the whole year. Also, the combination of the length of day and the angle of the sun at that time of year at that latitude creates a lot of contrast, with bright colors and deep shadows, what my artist friend calls *chiaroscuro*. At night the phosphorescent phytoplankton is very dramatic.

"We stayed at Spencer Spit (pretty spot, but rocking from passing ferries); Jones Island (which is a nice size to explore on foot); Stuart Island (also very nice); and Turn Island, near Friday Harbor

"As far as 'don't miss' places we really enjoyed our overnight in Friday Harbor. It's the county seat of San Juan County, so there is a good collection of restaurants and shops, including a local West Marine. The setting is very picturesque, with views of the water and islands, with the Cascade Mountains and the big dome of volcanic Mt Baker as a backdrop. The marina facilities are



KIAPA

**How's the fishing in the Northwest? Judging by Sue's hefty salmon, it's not bad. But Pete says a fishing guide will increase your 'luck'.**

top notch, very clean and well staffed.

"The big discovery this trip was the hiking on Cypress Island. From Pelican Bay, on the NE end the trail, to the top of Eagle Cliffs is a bit under two miles.

It's a pleasant hike through ferns and fir trees. The Cliffs are very prominent from the water, but this was the first time I had hiked to the top of them. The view far surpassed my expectations. They are several hundred feet directly above the water, with panoramic views over Rosario Strait, Obstruction Pass, and points beyond.

"The other attractions of Cypress Island are the hiking trails criss-crossing this heavily forested island."

— *chris northcutt*  
san francisco

We lived and worked there for 5+ years before moving to Puerto Vallarta. Great place.

My best and favorite crab bait was always, raw turkey legs — always got large keeper crabs with them. A 'keeper' crab is one that the State of Washington says measures 6 inches from tip to tip across the back. To have a smaller crab in your possession is bad news to you and expensive. The fines are steep."

— *capt. debbie orlando*  
echoes of summer.

**Right Equipment! Lowest Cost!**

**Price Guarantee  
BEAT ANY OFFER  
BY \$100!**  
Call for Details

**Save 15% on your  
next Footloose  
getaway!**  
Call for details  
or visit us online

**www.FootlooseCharters.com**  
**888-852-4666**

**Footloose**  
SAILING CHARTERS

# SAN JUAN ISLANDS



## 6-Day Learn-N-Cruise

Fly to Bellingham, WA and complete your American Sailing Association Basic Sailing through Bareboat Charter Certifications during a Saturday 1pm - Friday 1pm live-aboard week exploring the spectacular San Juan Islands. Tuition only \$1395, including food! (Airfare SFO/OAK to BLI approx. \$350)

*No experience like this for the price in the SF Bay Area!*



**CHARTER**  
40 Exceptional Yachts  
from 30 - 49 feet

*25 Years of Sailing Excellence*

*We certify more Bareboat Skippers than any other school in the Northwest!*

**1 - 800 - 677 - 7245 • sanjuansailing.com**



### Crewed Vacation in the Beautiful San Juans...

*"Thanks Grif and Judy for a wonderful trip. We loved spending time with you and learning from you. We have already recommended you to our friends and family!"*

*- Sandy and Helene*

Relax... Take the helm... Learn more, or just enjoy the sail and scenery. Great food, fun crew, private cabins. 5 nights, 6 days, \$1400 p/p

[www.sailnw.com](http://www.sailnw.com) • 707-245-7490  
Sailnorthwest Charters, LLC, Bellingham WA



**A refreshing new brand of sport clothing and accessories for today's female boater**

#1 - 2620 North Harbor Loop  
Bellingham - Washington - 98225  
Ph: 360-671-6427

To become an official Nautigirl retailer contact  
Christine Palmerton - christine@nautigirlbrands.com

[www.thenautigirl.com](http://www.thenautigirl.com)

## ANACORTES YACHT CHARTERS

PACIFIC NORTHWEST ADVENTURES

Largest Selection of Charter Yachts in the Pacific Northwest

Bareboat & Skippered

Power and Sail  
28'-66'

Charter Yacht Ownership

Yachting & ASA Sailing Schools



*Rated #1 in the World  
by Cruising World Magazine*

See us  
at the Seattle  
Boat Show  
1/29-2/6

[www.ayc.com](http://www.ayc.com) 800.233.3004

What's a summer day's cruise in the Pacific Northwest?

*How about 17 hours of daylight!!!*

- San Juans
- Gulf Islands
- Desolation Sound

## Bellhaven Charters

Power & Sail Charters  
Crewed or Bareboat  
ASA Sailing School  
Power & Sail Yacht Sales

See us  
at the Seattle  
Boat Show  
1/29-2/6

[www.bellhaven.net](http://www.bellhaven.net)  
[bellhaven@bellhaven.net](mailto:bellhaven@bellhaven.net)

BELLINGHAM, WA

877-310-9471

## Custom Canvas & Interiors



The Gianola Family has been designing and fabricating custom canvas and interiors since 1969. Gianola Canvas Products offers you the best in quality, more choices, and personal service.



265-B Gate 5 Road  
Sausalito, CA 94965  
(415) 332-3339

[www.gianolacanvas.com](http://www.gianolacanvas.com)



# MODERN SAILING SCHOOL & CLUB

Sausalito, CA

www.ModernSailing.com

(415) 331 - 8250

Get your Coast Guard Captain's License.

February 15 - 27  
2 week intensive

**OUPV LICENSE**  
**\$995**

**100 TON LICENSE**  
**\$1195**

Our GUARANTEED, U.S. Coast Guard Approved course will prepare you for all elements of the exam, guide you through the application process, and conclude with on-site testing.



with John Connolly

## Advanced Certifications in Exotic Locations

### South Pacific

\$2700 / berth  
\$4995 / cabin

LEG 1: April 23 - May 3, 2010 (1 SPOT LEFT)  
LEG 2: May 6 - 16, 2010 (SOLD OUT)  
LEG 3: May 20 - 30, 2010 (SOLD OUT)  
LEG 4: June 3 - 13, 2010 (1 SPOT LEFT)



Plan your vacation in this sailor's paradise today!

### Spain / Morocco - 2010

LEG 1: Oct. 30 - Nov. 8 (Mallorca-Gibraltar)  
LEG 2: Nov. 11 - 24 (Gibraltar-Canary Islands)

Leg 1	Leg 2
\$2475 / berth	\$2900 / berth
\$4450 / cabin	\$5220 / cabin

Obtain your OPM (ASA 108) on Leg 1.

Join us on our next Moroccan Adventure. After sailing through the Mediterranean, we are heading south with the wind, making stops in Casablanca and the famous Rick's Cafe. This is one of the most interesting places to sail, so mark your calendars and book your cabin today. Don't wait - this trip will sell out!



## PREPARE TO TAKE THE HELM

# AQUAMARINE

Watermakers Since 1987

SPARKLING FRESH WATER, POWER, AND REFRIGERATION FROM THE SEVEN SEAS

110 VOLT / BELT DRIVE



MODULAR KIT



HYDRAULIC

Hydraulic Motor



UPGRADE MOUNT



316 S/S REMOTE PANEL



12 VOLT DC

AquaGen combines the quality, simplicity & reliability of AquaMarine, Inc. watermakers with the durability of the Kubota 150 amp 12V diesel generators. This compact low fuel consuming AquaGen is a powerhouse, capable of producing up to 150 amps, and 8 up to 62 GPH of fresh potable water from any water source. Make fresh water, refrigeration, and also charge your batteries all at the same time! A hydraulic pump may also be added to run your dive compressure, windless, bow thruster, or emergency bilge pump. Ideal for longterm cruisers or weekend wanderers. We custom engineer our systems to fit any size vessel or cabin site. Electric, Hydraulic, or Belt Driven Modular Kits are also available. Visit our Website for more information.

QUALITY AT AFFORDABLE PRICES.  
LIFETIME WARRANTY ON PUMP HEAD AND PRESSURE VESSELS.

AquaMarine, Inc., 58 Fawn Lane (P.O. Box 55) Deer Harbor, WA 98243 USA  
(800) or (360) 376-3091 Fax (360) 376-3243

www.aquamarineinc.net

## YACHT CHARTERS IN GREECE, TURKEY AND CARIBBEAN

Best Rates For Reliable Charters  
Full services: Low airfares, hotels, tours, transfers

Visit our website for yacht photos and details, destinations and itineraries:  
[www.albatrosscharters.com](http://www.albatrosscharters.com)

Sailboats • 30'-60' Bareboat/Crewed Monohulls & Catamarans  
Luxury Sail & Motor 5 to 60 Guests

**Albatross**  
An American owned and operated company

**(800) 377-8877**  
**(856) 778-5656**  
Box 250, Moorestown, NJ 08057

**SAIL AND SCUBA DIVING IN GREECE**

## State Farm®

Providing Insurance and Financial Services

**Call Us For A FREE Quote Today**

**Jon Jones, CLU ChFC LUTCF**  
Agent Lic. #0540977

**(650) 583-3927**

333 El Camino Real, Suite A • So. San Francisco, CA 94080-5923  
[jon.jones.b8c4@statefarm.com](mailto:jon.jones.b8c4@statefarm.com)



Tortola BVI  
Belize  
The Grenadines

UNIQUELY  
**TMM**

Marisa  
TMM Belize

Most charter companies offer blue water & palm trees, but it takes the personalized care of people like Marisa to make your vacation a success.

Like Marisa, everyone at TMM is committed to your complete satisfaction. Our specialized three-location operation offers large company quality with small company service. A combination that is uniquely TMM.

**TMM**  
Yacht Charters  
Since 1979

catamarans • monohulls  
motor yachts  
ownership programs

Real People. Real Sailing. Real Fun.

Sail Cats | Power Cats  
Monohulls | Trawlers  
Bareboat | Skippered

Real Choices.

Choose CYOA and become part of the family. We've been providing beautifully maintained yachts, personal service and sensible prices to sailors since 1980.

1-800-944-2962  
info@cyoacharters.com  
www.cyoacharters.com  
St. Thomas USVI 00802

**CYOA**  
YACHT CHARTERS

**BRITISH VIRGIN ISLANDS**  
**"BEST DEALS ON KEELS"**

- Most selection of sailboats 32'-52'
- "Purr" with cats 38'-47'
- Bare boat or skippered
- Best yacht management program

**Conch Charters**  
Est. 1986

**NEW YACHTS IN FLEET!**

**www.conchcharters.com**  
Email: [sailing@conchcharters.com](mailto:sailing@conchcharters.com)  
Call our 'Sails' Office  
(USA) (800) 521-8939  
Tel (284) 494-4868 • Fax (284) 494-5793

*Sail paradise with Conch Charters*

**CALIFORNIA'S CARIBBEAN CONNECTION**



"We had a true, worry-free 14 days of sailing. We got everything we asked for and then some!"  
A satisfied BVI Yacht Charters Guest



Call: +1 888 615 4006  
Or: +1 284 494 4289

BVI Yacht Charters is the first port of call for all yacht charters in the BVI. Whether you are looking for Bareboat or Crewed yachts, a Catamaran or a Monohull, a week or just a few days, our professional team is on hand to make it work, your way.

**BVI YACHT CHARTERS**  
**www.bviyc.com**  
**charters@bviyc.com**

# CHANGES

With reports this month from **Sea Bear** on the last leg from Maine to the Virgins; from **Lagoon 380** sisterships on Banderas Bay; from **Antares** on dealing with the summer heat on the Rio Dulce; from **Wanderlust 3** on having to do an engine fix after an anti-siphon valve failure in St. Martin; from **Manu Rere** on food shortages at Funafuti; from **Le Chat Beaute** on losing an escape hatch at sea; from **Profligate** on Yelapa; and **Cruise Notes**.

## Sea Bear — Whittholz 37 Peter and Marina Passano Bermuda to the British Virgins (Ex-San Francisco / Maine)

We arrived safe and sound in the British Virgins from Bermuda on November 30. Our landfall was Anegada, the easternmost island in the group, and home to over 300 shipwrecks.

The weather for the passage was wonderful — for everything but sailing. Although it was late in the year in the Atlantic, we had sunny and warm days with smooth seas. But the winds were light and often out of the south, which forced us to tack a lot — not *Sea Bear's* strong suit. Marina's stomach liked the conditions just fine.

Normally one would expect to pick up the northeast trades between latitudes 25° and 22°N. We didn't get them until 19°N, at which time we were only 30 miles from Anegada! When we did get them, they were minor league stuff. So by the time it was over, we'd been forced to motor 40% of the eight days and 906 miles. We're pleased to report that the new engine ran like a Swiss watch — and almost as quietly.

A highlight of our passage was seeing a four-foot-long turtle 150 miles from land. Based on the distinctive ridges on its carapace, Marina identified it as a leatherback. When we first saw it, its

**'Sea Bear' being launched in Santa Venetia Creek in Marin County. She's been all over the world — and around the Horn — since then.**



COURTESY BOB VAN BLARICOM



COURTESY BOB VAN BLARICOM

head was so large that we thought it was a human's.

It was very cold when we left Maine, so we brought along warm clothes. But the day we arrived in Anegada, the air and ocean temperatures were in the 80s. That meant we no longer needed all the long johns, fleece and other stuff. By the time we gathered all our cold stuff, there was a mountain of it! We had no idea what to do with it all, as we certainly couldn't give it away in the tropical islands.

A couple of days after arriving in the Virgins, we took a sail down the Sir Francis Drake Channel. We were surprised to see how many of the charter boats are catamarans these days. I'd estimate there were two cats for every monohull. They were everywhere, mostly motoring around with their mainsails up. A lady from The Moorings explained the popularity of cats to us: "Two screws are better than one!" That kind of brought us up short, but we couldn't disagree.

When we sailed into the anchorage at Coral Harbor, St. John, in the U.S. Virgins, we were taken by the sight of *Gaucha*, a beautiful 50-ft Colin Archer design built of wood. The next morning, John, the owner of *Gaucha*, rowed over to admire *Sea Bear*, and which gave us a chance to chat. He told us that he was the fifth owner since Ernesto Uriburo, but that he and his family — including three kids — had lived aboard for 23 years. *Gaucha* still has her beautiful shape, and I complimented the owner on how well she'd been maintained. This item will be of little interest to many people, but there are a few old-timers who will appreciate it.

Coral Bay is a very laid-back and funky place. It has lots of character boats — and characters! Besides a number of Colin Archers, there were seven Block Island schooners built here — five of them on top of each other in the same mold!

— peter 12/05/09

## Three Lagoon 380s On Banderas Bay

Everybody seems to have a different idea of what makes a good cruising boat, which is the reason you rarely see sis-

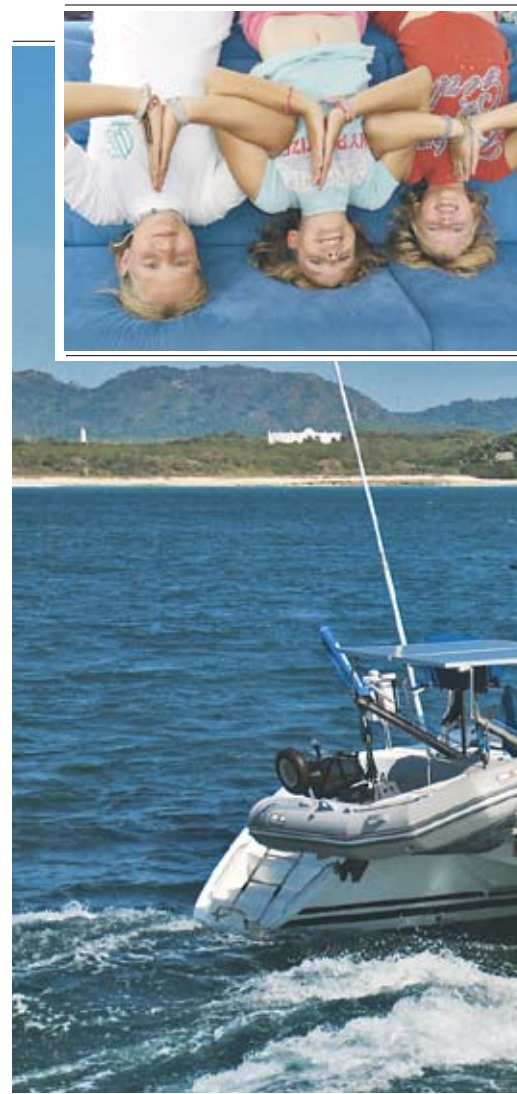

terships in the same anchorage. That's why we were surprised to see three Lagoon 380 catamarans together on Banderas Bay during this year's Blast — knowing that a fourth was going to arrive shortly.

The 380s were: Glenn Twitchell's Newport Beach-based *Beach Access*. He's owned the cat for several years, and for the last two years has done both the Ha-Ha and cruised Mexico. Then there was Mark Sciarretta's San Diego-based *Younger Girl*, which he's slowly been delivering to San Diego since buying her in Florida a year ago. Mark is one of the few people who has decided that he likes monohulls better than catamarans. His primary complaint — and it's a legitimate one — is that you don't actively steer cats as you do monohulls. He misses that, so he'll be putting his cat up for sale in California in the next few months. Finally, there was the Medina family's Colorado-based *Eleganz*, soon to be renamed *SEA Parents*. This wonderful family — Troy, Brady, and daughters

# IN LATITUDES



ALL PHOTOS LATITUDE/RICHARD

chance of getting hit by a hurricane in the Caribbean. Despite my clever timing of the spring tide at Livingston, which is at the mouth of the river, we still ran aground on the bar. Getting towed into Livingston sideways was fun. But the trip up the river gorge from Livingston was stunning. It's a real jungle, with blazing green vegetation and screaming parrots and monkeys. Once we tied up the boat at Mario's Marina, we stayed put. Nonetheless, we started everything regularly. For on boats, as well as with people, 'motion is lotion'.

Mario's is located at Fronteras, which is just a wide spot in the river a few miles downstream of Lake Izabel. Someone started a marina here years ago, and now scores of cruisers like us come to stay at the many marinas that cater to boats hiding from hurricanes. There are lots of people to play with here, although many cruisers just leave their boats for long periods to do inland trips to avoid the heat. There are also many restaurants, some places with boat parts, and a real fuel dock. Fronteras is a throwback to the Wild West, as there is one main street along the river with open stalls and markets, but no sidewalks. And, there is the occasional real shooting.



*The gorge of the Rio Dulce is stunningly beautiful. And hot!*

The main reason we chose Mario's over the other marinas is that it has a luscious, shaded pool. Unlike the water in the river, the pool water is very cold because it comes from springs high in the mountains. But who cares where it comes from, because on blisteringly hot

**Jeff and Phyllis cruised the Caribbean for 2½ years aboard an Amel 48 in the '80s before moving to Mendocino to raise their son.**

**Spread:** Glenn Twitchell's 'Beach Access', one of the three Lagoon 380s around for the Blast. **Inset left;** The adorable Conger girls, Jaime, Mera and Aeron, practicing upside down yoga on 'Profligate'. **Inset right,** the equally adorable Medina girls, Samantha, Emily and Ashley, with mom Brady.

Samantha, 9, Ashley, 8, and Emily, 6 — purchased the cat four months ago in Puerto Vallarta and intend to sail her around the world.

It would have been really interesting if *Eleganz* hadn't been in such a hurry to get going, because yet another sister-ship — with a 'sistercrew' — was about to arrive on the bay. This was the Seattle-based Conger family's *Don Quixote*. Veterans of the '08 Ha-Ha, the Congers are similar to the Medinas in that they also have three girls: Jaime, 13, Mera, 11, and Aeron, 9. It's not uncommon to see cruising boats with two and sometimes three young boys, but we can't remember ever seeing a cruising boat with three girls. And this would make two of them.

During last year's Sea of Cortez Sailing Week, we 'borrowed' the hilarious Conger daughters for two afternoons, including the Isla San Francisco to Isla

Partida race. And during the Blast, we had a lot of fun with the Medina girls. On both occasions we were flooded with fond memories of the great times we had sailing with our daughter Lauren — now 28 — when she was a similar age in places such as Mexico, Costa Rica, the Med and Hawaii. You never forget memories like that. As girls grow into their teens, identities become more developed and complications arise, so we think pre-teen is a great time to take kids cruising. But you don't necessarily have to do it aboard a Lagoon 380.

— latitude 12/09/09

**Antares — Amel 53  
Phyllis and Jeff Rapp  
The Rio Dulce  
(Healdsburg)**

Man, is it hot! In June we motored 25 miles up the Rio Dulce to escape the



ANTARES

COURTESY ANTARES

# CHANGES

days, it feels wonderful to jump into the pool and freeze your ass off. It's so hot here on the river in the summer that you get sweaty from doing just a few



**Spiders in Guatemala can be big and furry.**

minutes' work on the boat: making a bed, walking to the pool — or even just thinking about doing any of those things. Jeff, who is well-known for being a good 'sweat-er', sweated so much that he had to install windshield wipers on his glasses in order to see. After two weeks of living in the oven that is Mario's, we travelled to Antigua, a delightful colonial town in the mountains — and therefore cool. Once the capital, Antigua is quaint and has numerous attractive hotels, restaurants, museums and bars. Plus, there are lots of outdoorsy things to do. For example, we climbed an active volcano. Since Guatemala doesn't have too many lawyers yet, the guides not only allowed us to get as close to the hot lava as we wanted, but even brought along marshmallows so we could roast them over the hot rocks. Unfortunately, one of us got too close — guess who — and crashed through the newly hardened lava, shredding his/her arm. When we threw the blood-soaked tissues onto the hot rocks, they immediately blazed up, giving the incident powerful religious overtones.

Even though one of us hates horses, he/she insisted — "because of extreme fatigue" — on hiring one for the trip up the volcano. On the way down, our guide

**Once the director of ER at St. Luke's Hospital in San Francisco, Jeff now limits his operations to the diesel on 'Antares'.**

fell, severely injuring his ankle. He had to be taken the rest of the way down on another horse. Ultimately, we were all stranded, and had to eat the horses in order to survive. But that's another story. The two of us were by far the oldest farts on the trip. We only went because the tour company assured by that "anyone" could do it. Ha!

We also rented mountain bikes and toured the surrounding area. It was very interesting until the heart attack. Part of the trip was a tour of a macadamia nut factory. They claim to supply the oil for various obscenely overpriced Lancôme products that one of us uses to excess. Before it was over, we'd enjoyed two wonderful weeks in cool Antigua, spending only the Monopoly money that is a time-share exchange. But prior to leaving Jeff started a relationship with a scarlet macaw, despite hotel's many signs warning patrons not to approach or touch the bird. I assume she was in love.

Before Jeff's 91-year-old mom died, forcing us to suddenly rearrange our plans, we'd made plans for a long trip back to the States. American Airlines either couldn't or wouldn't help. The best we could do was dovetail a completely separate trip onto our pre-existing trip in order to attend the funeral. So after being in New Jersey, New York, Massachusetts and Miami, we had to fly back to Guatemala City for one night, at which time we started our original trip to Miami for a connecting flight to San Francisco! Cruisers beware.

After visiting countless family members and friends in different parts of the country, we returned to *Antares* with — what else? — two big bags full of boat parts. Unfortunately, we got back in September, the hottest month in the Rio Dulce. It was so hot that we took another trip to a higher elevation, this time to Lake Atitlan. What a joy that was, as it was cool, the water was cool, and the Casa del Mundo was a spectacular but surprisingly affordable hotel. Every room had a perfect view of the then-full moon, surrounding volcanoes, water and sunsets.

We also travelled to Peten Province, which was another success. The best part was trekking through the jungle and getting to see lots of wildlife and flora. We had a great guide who



told us all about Mayan culture. For example, we learned that the captain of the losing ball team had his heart cut out. That raised a lot of interesting questions about motivation and sportsmanship. I hate to say this, but to my thinking, once you've seen one Mayan pyramid, you've seen them all. My great idea is that they should completely restore one of the ruins, even if they have to use plaster, paint and new sculptures. This would have the practical benefit of protecting it from the elements, and give the average schmuck an idea of how they really looked. They could even hire living Mayans — or Incas or Greeks — to dress up and hang around. It would be good money for these people, who are often very poor. Maybe they could even stage a ball game, and cut out the heart of the losing captain.

I'm always amazed at the scams being tried on *gringos*. Millions of years ago we drove down the Baja peninsula where, in the middle of the desert, an old Mexican guy with a vaguely military-looking hat



# IN LATITUDES



ALL PHOTOS COURTESY ANTARES

**Spread:** An Amel Maramu 53 like 'Antares', an iconic French design if there ever was one, in full flight. **Inset left;** Phyllis, a retired RN, stands halfway up the volcano that "anybody could climb." **Inset right;** Central America has provided inspiration for Phyllis, an accomplished artist.

had placed a log in the middle of the highway. We had to pay a small 'toll' to get through. Well, on our bus trip to Flores, the bus stopped about 10 miles from town, at which point a guy got on the bus to inform us that we had to get off and take a mini-van the rest of the way. Naturally, there would be an extra charge to complete our trip. I may have gone for it, except I noticed the guy only gave *gringos* the news. When I told him that we were staying on the bus, he shrugged and continued on. Sure enough, the original bus took us right to Flores like it was supposed to. Cruisers beware.

Having survived the summer and fall, we left the Rio Dulce in November the same way we entered — on our side, tipped over by a masthead halyard pulled to the side by a fishing boat off our starboard beam. Going out was a

lot easier than coming in had been, and we probably could have made it in on our own. But we'd already contracted for the tow which, given the problems on our first crossing, was the sensible thing to do. We're now anchored in a beautiful bay on the other side of the Bahia de Santo Tomas de Castilla from Livingston, the latter being a curious name for a Spanish pueblo. *Antares* had been moved only twice since we arrived at Mario's Marina in June. Once was to a shakedown cruise/party to Lake Izabel that was attended by about 15 boats. The other was a pre-departure trip to Texan Bay, closer to the river mouth. True to its name, everyone at Texan Bay "talks lak thee-is" — and smokes a lot of herb. Once

again, the river gorge was stunning.

What to make of our five months up a river? We did it to avoid hurricanes

— although this year we could have done that by going anywhere we wanted in the Caribbean. Five months is a long time to stay in one place, although we weren't even on our boat for half of it. The Rio was beautiful, but did I mention that it was really hot? We made many friends, whom we saw and played with nearly daily. It's

one of the odd things about cruising, that you become better friends with your new friends than your old land-based friends. And then you part, probably never to see each other again. It's sort of like being a schoolkid again.

At this point, I feel a little like I've escaped, because I didn't like being 'trapped' up a river. Anyway, our next stop is Belize, home of clear water, thousands of cays, and a huge barrier reef for snorkeling, diving and living on the hook again. We're ready!

— phyllis 11/15/09

## Wanderlust 3 — Hunter 49

**Mike Harker**

### Do-It-Yourself Diesel Repair (Manhattan Beach)

How could the failure of an \$80 part potentially cause \$8,000 in damage to my boat's Yanmar 4JH4 HTE diesel? I'll tell you, so you can keep it from happening to your engine. The \$80 part in question was a corroded Vetus anti-siphon valve in the exhaust system of my diesel.

**Finding saltwater in the #3 cylinder of the diesel. It's not a cruiser's dream, but rather an expensive and time-consuming nightmare.**

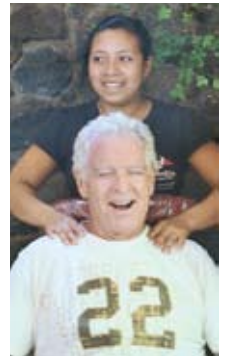

**Jeff, enjoying a medicinal rub.**



# CHANGES

If there is a problem with the anti-siphon valve, seawater can be sucked back into the engine's cylinders. Perhaps I would have discovered the problem with the valve if had I more experience with boat diesels. Or if the owner's manual didn't identify the part as not needing any maintenance!



**Harker plays with his oily Yanmar on the salon sole.**

I was spending the summer at Simpson Bay Lagoon in St. Martin in the West Indies. After taking refuge in the Mullet Pond mangroves when hurricane *Bill* threatened during the summer, I returned to my normal spot in the lagoon. Then, for seven weeks I never started my Yanmar. This was a mistake on my part. I should have run the engine every week, even if just for a few minutes. But as my boat is equipped with three large solar panels, an Air-X wind generator, and a 12-kW generator, I never needed to run the main engine for power. In fact, I used the generator only about three hours a week to top off my battery banks and make water.

What I didn't know, is that during this time the anti-siphon valve at the top of the seawater outlet that cools the intercooler on the Yanmar was corroded. Since the little flap wasn't closing, it allowed seawater to be siphoned back down the hose and into the exhaust manifold — including back through the turbo — and finally into the open exhaust valve of #3 cylinder.

As a result, my Yanmar wouldn't turn over when I finally tried to start **Yes, after having had sea water sitting in it, which prevented the engine from turning over, the #3 hole looks like it needs work.**

it. Puzzled, I put a 14mm socket on the shaft nut near the alternator belt. I had no luck when I tried to turn the engine that way. Stumped, I called for the local Yanmar mechanic to come to my boat. He took off some hoses and the valve cover, then showed me how the #3 cylinder had filled with seawater.

Hoping for some warranty relief, I called the Yanmar distributor in Florida. They told me that the anti-siphon valve "wasn't a Yanmar part." As for Hunter, they said my boat was out of warranty, and in any event the anti-siphon valve was a maintenance problem not covered under warranty. When I asked the Yanmar dealer in St. Martin for a quote to fix the engine, I was told they would need \$5,000 in cash — in advance — just to have them look at the damage. This would, however, include their towing my boat to their facility, using a crane to lift the engine out, and having the engine in the shop for three to four weeks. I was also warned that if the turbo had been damaged, or if the head or valves needed work, the total cost could come to over \$8,000. All this because of a stuck anti-siphon valve!

I'd grown up in Southern California, where my dad and uncles raced boats and did their own engine work. As such, I'd seen engines in pieces at the launch ramp during all-night Saturday night engine rebuilds before the big races the next day. Based on that heritage, there was no way I could pay \$8,000 to have someone else fix my diesel. So I purchased a Yanmar service manual for my engine, and had the Yanmar folks at Mastry Engines in Florida send me all the parts they thought I would need. This included a new piston and rings, injector tips, and all the seals and gaskets for a complete overhaul. Doug Dykens, the service manager at Mastry, was particularly helpful. When the parts arrived, they came with good wishes from the folks there.

As much as I wanted to be self-sufficient, I felt that this wasn't a project that I should tackle alone. That's why I was so lucky to have come across James, a retired diesel expert who had been living on his boat in St. Martin for years. He'd worked on many diesels over the years, including those on old boats and trucks, but this would be the first time he worked

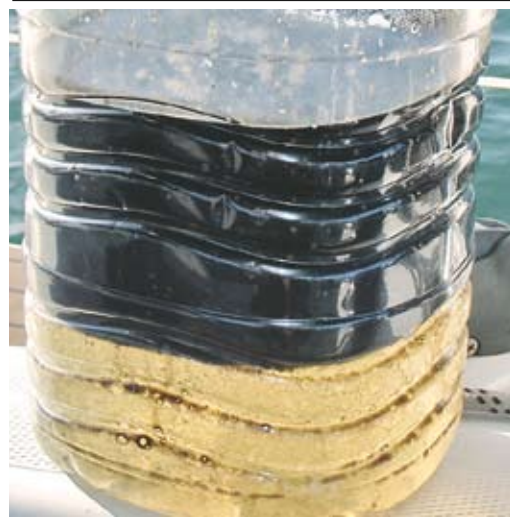

on a turbo-charged, four-valves-per-cylinder modern sailboat diesel.

Our first step was to get the heavy diesel out of the bilge and onto the salon floor. We placed a steel bar across the top of the companionway, then used a borrowed chain hoist to lift the engine out of the bilge and onto boards we placed on the salon sole. This required that the companionway steps be removed, which meant for the next week or so, I had to enter and exit my boat through the forward hatch. It wasn't easy, given the injuries I'd suffered to my legs years before as the result of a near-fatal hang gliding accident.

The next job was to get the bad piston out. James and I took turns whacking at the piston, drilling some holes in it, then whacking it again. It took us a full day to get the seized piston loose and remove all the pieces. I then bought a special honing device that attached to my power drill. Following the instructions in the Yanmar shop manual, we cleaned up and polished the inside cylinder wall.



# IN LATITUDES

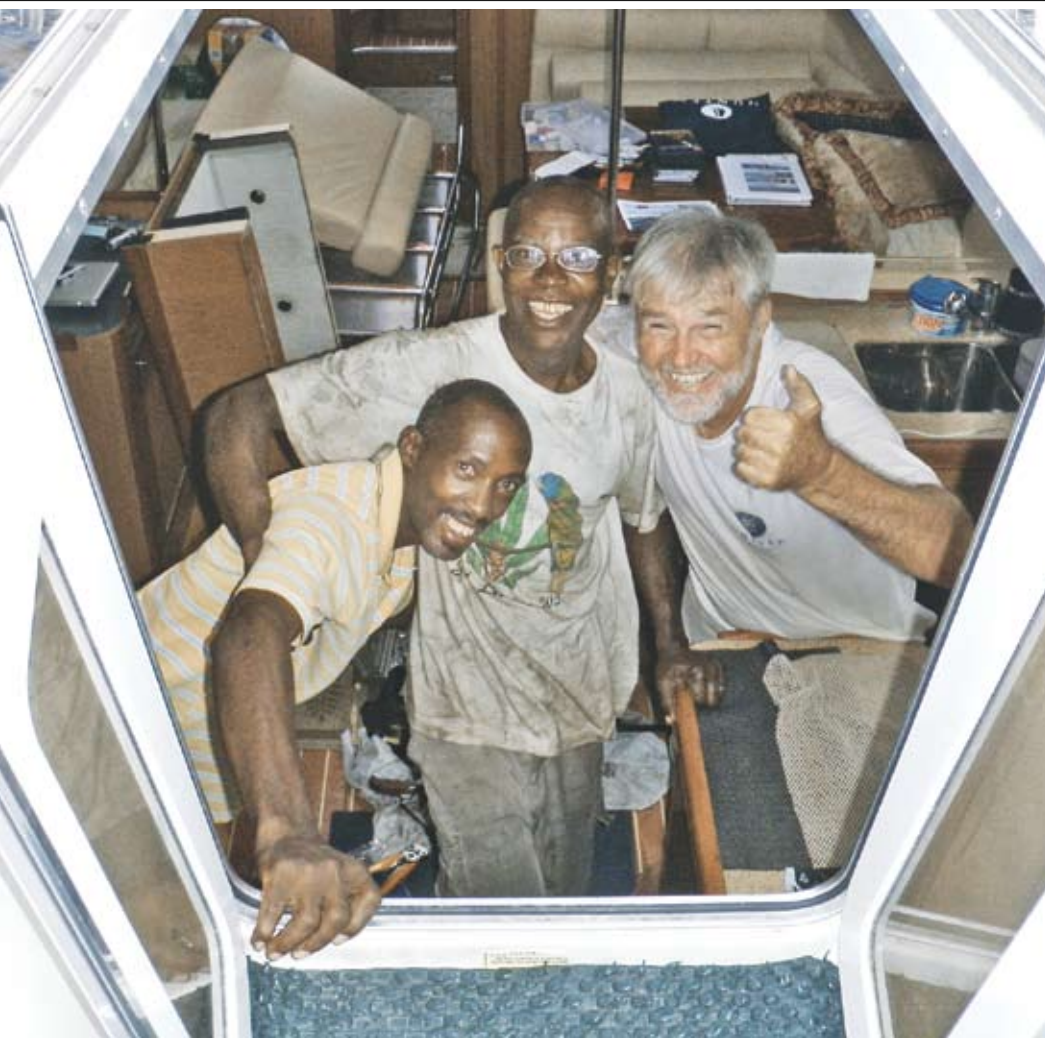

ALL PHOTOS COURTESY WANDERLUST 3

**Above: James the mechanic, a friend and Mike. Lower left; Looks like a bad piston. Upper left; This much water in the oil is a bad sign.**

I put the valves into a cardboard box, carefully marking each valve and its corresponding hole in the head. I then took it all to an excellent machine shop that specializes in racing engines. They returned it the next morning looking better than new for \$250. I also had James take the turbo over to the airport, where a specialist works on turbines and other specialized equipment. It was returned the next morning also looking as good as new. The cost was \$200, including new seals and bearings.

Finally, after seven continuous days of our working up to 10 hours a day, the engine was back in place, the electrics and plumbing reinstalled, and the key ready to be turned. As soon as the key was turned, the Yanmar started and purred like a kitten! I felt a great sense of elation, and a great sense of accomplishment. After four hours of running the engine at idle speed, I changed the

oil and filter. The oil was a bit dirty and had some diesel mixed in. After 10 hours of running the engine up to 1,800 rpm while on my way to St. Thomas and back, I changed the oil and filter again. This time it was perfectly clean.

After 25 hours on the repaired engine, I hired one of the off-duty Yanmar service technicians to come to my boat to check the engine out. He was slightly impressed that everything seemed to be working perfectly. Almost as an afterthought, he checked the anti-siphon valve — and it was almost clogged up once again! He corrected the problem by shortening the anti-siphon relief hose to a visible position just above the bilge.

So for about \$800 in parts and about 80 man-hours, I got my engine apart, repaired, and back working again. I do not, however, recommend that anyone try to do the same

thing without the help of professional diesel mechanic. But if you're desperate, I guess we proved that it can be done. Having subsequently talked to lots of other more experienced boat owners and diesel mechanics, I've learned that plugged up anti-siphon valves are one of the most common causes of expensive engine repairs. Check yours often!

— mike 12/03/09

## **Manu Rere — 38-ft Polynesian Cat Glenn Tieman Wallis and Funafuti (Oxnard)**

Although Wallis Island — a French collectivity located at 13°10'S and 176°08'W — has a beautiful lagoon surrounded by lusciously wooded islets, I stayed only two weeks. There were three reasons. First, there wasn't a good anchorage that was also convenient. Second, the islanders were — for being Polynesians, at least — relatively inaccessible.



**Glenn and friends playing at the pier.**

Finally, the prices of things were two to three times that of already expensive Tahiti.

What I enjoyed most at Wallis was spending three days daysailing between the pretty islets, and anchoring alone at several stunning spots while I made improvements to my boat's rig. Details such as brailing, I discovered, required lots of trial and error.

I then made a routine one-week passage to Funafuti — routine in the sense that I had some fine conditions, some stormy conditions, and a couple days of calms. When the waves get big enough

**The French collectivity of Wallis Island. Despite being in the South Pacific, it has some islets with luscious forests!**



MANU RERE

# CHANGES

to make the self-steering a little squiggly, I've learned to set a small drogue consisting of two fathoms of chain. That straightens *Manu Rere's* course without slowing her noticeably. If things get stormy, I shackle the chain around an old tire for even greater control.



**Glenn's outrigger in proa mode. She's great fun to sail.**

Funafuti is a place I remember fondly from my visit 22 years ago, when I was doing my 10-year cruise aboard my 26-ft catamaran *Peregrine*. Funafuti was the first atoll I'd ever seen, and it was so clean, bright, wind-swept and simple that it left a deep impression on me. This is a place where I feel comfortable. Although Funafuti is the capital of the island-nation of Tuvalu, it has less than 5,000 inhabitants, and it's a bit of a shabby village. The locals are very friendly and everything is casual. So casual that the one bank doesn't accept credit or debit cards!

The only difficulty at Funafuti — apart from the government officials who are still trying to discourage tourism with high fees and other obstacles — is food. There's always rice, of course, and coconuts. And sometimes fresh fish is abundant and for sale at low prices out of ice chests along the lagoon-side road. Although local produce is sometimes given away, none is for sale. And I have a problem with produce imported from New Zealand.

The food problem prompted me to investigate alternative foods and alternative ways of keeping foods. It's hard for one man without refrigeration to eat even a small tuna before it spoils, so I ex-

**While at Tuvalu, Glenn would sometimes use his simple outrigger as a canoe. At other times, he would put up the mast and sail it as a proa.**

perimented with a technique for salting and drying fish. Then, after a freshwater soak, I fry it — and it tastes delicious! Fortunately, the sand seabed 10 feet beneath *Manu Rere* is carpeted with two-inch gastropods. After being well cooked, they are easy to remove from their shells and taste gourmet delicious. On the vegetable side, there is an edible plant called sea grapes that I could find just a short swim from my boat. And many locals have planted bele, which is an edible bush that, when cooked properly, tastes like Swiss chard. There is another kind of bush — I don't know the name — that has fruit sort of like a pear with dimples. I've seen it being cultivated on plantations all across Polynesia. It smells like sharp cheese — not a very appetizing quality in a fruit!

Fortunately, there are two libraries at Funafuti — which is twice as many as I ever saw in French Polynesia. While doing research in one, I learned about noni. It's a stinky fruit that Americans are apparently willing to pay high prices for in health food stores. After I collected the noni fruit from wild bushes, the juice ran out of the fruit and fermented. It was reasonably tasty.

Speaking of fermentation, a gallon of water mixed with 2/3 kilo of sugar and three teaspoons of yeast starts to get interesting after only three days. The yeast dies off after another two days and settles, leaving a strong, clear alcoholic beverage. It's barely palatable, but it is dirt cheap. I first encountered this very inexpensive way to make alcohol while aboard the boat of Henry Wakelam, a great sailor and author. I also saw it in Malaysian Borneo after the rice wine and sago wine had all been consumed.

Meanwhile, I've been dining with volunteers and diplomats from Taiwan, swimming at the old wharf with the kids, working on the boats, and sailing my proa dinghy. Funafuti is a perfect setting for sailing a proa, as there are miles of flat

water and tradewind breezes. I finished off my proa's mast step and other details after much experimentation. The big breakthrough was adding a windward side mast strut. Having completed it, I now have a fun, super exotic — and carbon-free way — of scooting about the lagoon.

*Manu Rere* is currently anchored safe



and sound inside the lagoon on the warm and bright green water. Two yachts may pass through here in the busiest week of the year, which is now, the start of the South Pacific cyclone season. These boats are heading north, instead of south to New Zealand, to avoid cyclones.

— glenn 12/03/09

## **Le Chat Beaute — Privilege 42 Paddy Barry and Dave Surridge A Hatchless Passage (Vancouver, Washington)**

We left the Chesapeake bound for the Virgins on November 1 under cloudy skies and in light rain. The wind was blowing 20 knots and gusting to 25 out of the northeast — brisk conditions. We were carrying a full genoa with three reefs in the main, making 8+ knots in 6-to-9-foot beam seas. The forecast called for 15-20 knots with six to nine-foot seas once we got to the Gulf Stream. These weren't ideal conditions in which to start a trip to the Virgins, but thanks to hurricane *Ida* developing in the Gulf of





# IN LATITUDES



SPREAD; GLENN TWITCHELL; INSET, LATITUDE / NICK

**Spread:** Polish model Ursula Szyrak shows how serious it would be if a near vertical escape hatch just above the waterline — as is common on cats like Lagoons — were to break. It would be much harder to keep water out than if a bridgedeck hatch broke. **Inset;** Lagoon 380 'Younger Girl'.

Mexico, we weren't going to get another decent weather window anytime soon. So it was either head for the warmth on November 1, or be cold for weeks.

We had just about made it across the Gulf Stream at 35°N, 74°25'W, and were roaring along at 9.5 knots, when I looked down into the salon — and saw a three-foot tall column of water surging up through the bridgedeck and into the boat!

Most catamarans have escape hatches on the bottom of the bridgedeck or the inside of the hulls so crews can escape in case of a capsized. On *Le Chat Beaute*, there are two escape hatches, covered with teak grates, that are part of the main salon floor near where the bridgedeck meets the hulls. In calm conditions, they are 30 inches above the surface of the water.

Anyway, I rushed to the starboard side escape hatch, thinking it had come

open. But no — it was gone! Having a hatch-size hole in the bridgedeck just 30 inches above the tempestuous seas meant that we took on water fast. Before long, the inside of the starboard hull was awash, and the bilge pumps were going full bore.

I always keep plywood on my boat for damage control, so I grabbed some of it along with the screw gun and screws. I then started screwing the plywood down to the salon floor. Meanwhile, I had Dave steer the boat downwind to stop the beam seas from ricocheting between the hulls and coming up through the hole where the hatch had been. Needless to say, it was a scary time.

After I covered the hole, I disconnected the shower

pump on the starboard side, and stuffed the hose in the bilge above the bilge pump. The hull was awash for maybe 15 minutes before the two pumps removed most of the water. Interestingly, I couldn't detect any difference in performance between when the hull had lots of water and when the water was all pumped out.

After I got the leak under control, I had to decide on our next course of action. We were just about out of the Gulf Stream on the east side, which meant we were about 90 miles from the Chesapeake, something less than that from ports on the south side of Hatteras, and about 1,180 miles from the Virgins. Although going back to the Chesapeake was only 90 miles, it didn't seem like the best option, as it would require sailing into the wind and seas. I discarded that idea because I didn't think my repair could withstand all the pounding while going to weather. Heading for the south side of Hatteras didn't look like such a good idea either, as the weather along the entire East Coast was getting worse by the hour. So even though it was 10 times farther to the Virgins than back to the Chesapeake, I decided that it would be safest to press on. My decision was helped by the fact the wind was forecast to moderate to 10 to 15 knots over the next 24 hours.

As we left the Gulf Stream, conditions settled down to 20 knots out of the north, gusting to 25. While these would have normally been ideal conditions for heading to the Virgins, we had to keep

**Paddy bolting down his more sophisticated repair once he got to the Virgins. He's now sourcing a replacement hatch.**



**Paddy sailed the damaged cat 1,200 miles.**



COURTESY LE CHAT BEAUTE

# CHANGES

our boat speed down to six knots. If we went any faster, the wave action would assault my repair, and water would fill the starboard hull again. The bilge pumps easily contained the inflow of water after my plywood repair, but they would still come on every 15 seconds.



**'Le Chat', back when her escape hatches were intact. But thanks to the failure and big seas, Paddy now has more faith in his cat than ever.**

One of the pumps eventually failed, so I had to replace it.

If conditions had ever gotten calm or even light, I might have been able to attempt a repair from the outside of the hull. But conditions remained vigorous. After putting 100 screws into the plywood sheet over the floor, I was able to keep most of the water out.

But the ocean eventually gets her way. When a 17-ft swell came under my cat and slapped the plywood sheet, it broke the cabin floor loose and left it raised about six inches! All of the sudden I was able to look right through the bridgedeck floor again and see the Atlantic Ocean, just a few feet down, in all her glory! After more screws and blocks in the walls to jam the floor, we were off again! But by that point I had reason to worry about running out of lumber.

When we finally reached 'Highway 65' — 65° longitude, which is where everyone makes their turn south to the tropics — we made our turn. Thanks to a north wind, along with more sun and

**New Lagoon cats come complete with fixed escape hatches — and 'Break Glass In Case Of Emergency' hammers.**



PAUL PUDDLESTONE

rising temperatures, the damaged main salon floor in my cat actually dried out. The rest of the trip was generally mild — although we did have 30 knots gusting to 40 out of the northwest for 30 more hours. But it was from astern, so it was mostly a wild slide down the 15-ft swells. Dave was amazed at how much better the conditions were with 30 knots of wind than 20 knots of wind. The stronger wind established a more consistent swell pattern, and the wind waves had less impact.

Until this point, I'd never been in any rough weather on a cat. Like many ex-monohull skippers, I'd always wondered about cats in bad conditions. But after this experience, I would go anywhere in a cat. Even though I had to spend lots of time with my head in the bilge, the cat's more gentle motion kept me from getting more than mildly seasick. Had I had to do the same thing in a monohull, it would have been a battle to make repairs and keep my lunch down.

The wind came out of the south at 5-10 knots the day before we arrived at St. Thomas, so we were forced to motorsail. It had taken us 10 days to reach the U.S. Virgins, as we'd slowed *Le Chat Beau* down to six knots for almost the entire passage in order to minimize damage to my temporary repair. It actually would have been a great trip, and the passage time acceptable, had I not been suffering from a high level of anxiety. But at no time did conditions prevent Dave and me from enjoying meals. In fact, we BBQ'd for half the trip. I talked to some sailors on 60-ft plus monohulls who arrived before us, and was told that when they ate — which wasn't often — it was out of cans. So in even the worst of conditions, life on a cat seems all right to me.

Dave Surridge had never been on a sailboat before this trip, and I can't say that he'll ever get on one again. But he did a good job, as he stood all his watches and was there when I needed him.

— paddy 11/25/09

## **Profligate — Surfin' 63 A Short Stop At Yelapa**

Banderas Bay is a place with many charms, one of the most interesting being the *muy, muy tranquilo pueblo* of Yelapa. Nestled in the southernmost cove of what is claimed to be the seventh largest bay in the world, Yelapa has long been a mecca



for those wanting to drop out. The attractions were that you could get there only by boat, so there were no cars or traffic; there was no electricity or phones; 'no shirt and no shoes' was no problem at the restaurants; and neither was firing up a big spliff.

A few things have changed in Yelapa. While it's still easiest to get there by boat, there is now a road of sorts. Quads have replaced donkeys for transportation and hauling things up the cobblestone trails. And not only does Yelapa now have electricity and phones, there's even an Internet cafe.

But much hasn't changed. It's still surrounded by a magnificent jungle, it's sleepy before the tourist boats have arrived and after they've gone, and credit cards are useless. The anchorage is still dicey because the bottom is so deep right up to the edge of the beach. That's why we were going to pay Bully \$10 to use a ferry mooring for the night. We would have paid him, too, except he disappeared before we could hand over the cash. We'll get him next time.



LATITUDE/NICK

**Clockwise from top left: A local girl works on rosewood in the outdoor shop; the lower falls; Yelapa has lots of flowers; the young delivery guys work hard for the money; Yelapa Cove; frolicking beneath the falls; a languid local; the outdoor lavanderia; jungle vegetation is often twisted.**

As many cruisers who have visited can attest, Yelapa Cove can still get rough and sloppy. We arrived on a Monday afternoon when the cove was flat and calm. But the swell and chop came up during the night, creating a cove full of heavy slop. Although *Profligate's* 30-ft beam tends to keep things smooth, one crewmember who never gets sick, did get sick.

We think the most fun destination at Yelapa is the waterfall. It's a short and gentle uphill hike, and in November, right at the end of the rainy season, there is still a lot of water free-falling from a height of 150 feet or so. Rumor has it there's an even higher waterfall farther up the mountain. In any event, the water tumbling down the lower waterfall is fresh and cold — the perfect thing for those who have overdosed on saltwater and humidity.

Yelapa may not have as many dogs, hippies and mystics as it once did, but

it's still a stop you don't want to miss.

— latitude 12/09/09

### Cruise Notes:

"I would like to send a huge 'thank you' to the editors, staff and the folks who send letters and articles to *Latitude*," writes Chris Juhasz of Southern California. "Although I don't currently own a boat, I — like many others — fancy myself a sailor based on my past — and hopefully future — sailing adventures. Because of *Latitude*, I recently had one such trip. I had read that singlehanded circumnavigator Mike Harker of the Manhattan Beach-based **Wanderlust 3** sometimes takes crew along on certain legs of his adventures. I applied, and before I knew it, it was November 3 and I was meeting him on his boat on the beautiful island of St. Martin. What

followed was just shy of three weeks of an amazing Caribbean adventure. My trip started with my learning some very important lessons about the cruising life. First, even rather new and well-maintained boats such as Harker's Hunter 49 can have issues. For when I got to the boat, the engine was lying on its side on the cabin sole, not looking as though it was going to propel us anywhere soon. I also learned that when things need to get done 'out there', you must take things as they



'Wanderlust 3'.

come — if and when they come. For if a part from the States was mistakenly flown to the wrong island, there would be no progress that day, period. It was a huge lesson in patience for me, and Mike was a great teacher. Soon enough — but not a day late — the engine was fixed and we headed off to the British Virgins.

"Once underway," Juhasz continues, "I was treated to some glorious sailing. The highlight was our overnight passage to Peter Island, during which time I learned much about sailing through squalls on black nights. We got hit by the hardest one just as we made our way past Round Rock at the entrance to the Sir Francis Drake Passage. It was very exciting stuff for me, and I loved it. Also exciting was the good-sized lightning storm that started to crack away at the hills surrounding the bay we anchored in. The next week was spent moving from one amazing anchorage to another, and seeming to find an even more beautiful snorkeling spot at each location. The time passed so quickly! Once again, I'd like to thank *Latitude* and all the contributors. Rejuvenated sailor Chris Juhasz of Southern California takes the helm of 'Wanderlust 3' as she exits Simpson Bay Lagoon.



MIKE HARKER

# CHANGES

tributors for giving me the push I needed to get out sailing again. After my 'Hangin' With Harker' adventure, my plan is to buy a new boat and start sailing to Two Harbors, Catalina, again. And eventually sign up for a Ha-Ha."

Frenchman Tom Blancart and his Aussie mate Kim report that their ketch **Karaka** was boarded by four men carrying machetes and guns late on the afternoon of December 2. They were transiting the Boca Chica Channel to **Cartagena, Colombia**, at the time. Already inside the bay, *Karaka* was about five miles from the city itself when the apparently well-orchestrated robbery took place.

"The pirates managed to get us under control before we could call for help," Blancart wrote in his blog, "and they took their time searching our boat for valuables. The experience was quite unpleasant, but nobody was hurt. However, lots of valuables — including electronics, computers and money — were taken. Once the pirates left, we called the police. The friendly officers arrived about half an hour later, but were fairly



CARLOS FERNANDEZ

**Most cruisers love visiting Cartagena, but recent thefts have accentuated the need to be cautious there — and avoid the Boca Chica.**

complacent about the whole affair. But they did escort us into the harbor."

The consensus around Cartagena is that the Boca Grande entrance is safer than the Boca Chica entrance, and

thanks to the red and green buoys that mark the underwater wall, it's easy to navigate, too.

Cruisers, who generally love Cartagena and feel safe there, also report that there has been a recent spike in dinghy thefts around the Cartagena anchorage and surrounding areas. However, all the dinghies that were stolen had apparently been left unlocked in the water. It's incomprehensible to us — having had a dinghy and outboard stolen there after they went unwatched for three minutes — that anyone would leave an unlocked dinghy in the water overnight in that part of the world. The *Guardia Costa* believes that the dinghies are being stolen by *banditos* who swim out from the street between 2 and 4 a.m. Many cruisers believe that dinghy and other thefts increase in the weeks before Christmas, as the thieves need money to buy Christmas presents for loved ones. In any event, you've been warned.

"We're happy to report our recent haul-out at Rebak Marine in Langkawi, Malaysia, went well," wrote Capt. Fatty



**We help make El Salvador worth the trip!**

Visit our Web site [www.barillasmarina.com](http://www.barillasmarina.com) to learn more about our many amenities including high speed Internet, on-site customs and 24-hour security.



Barillas Marina Club is the premier cruising destination in El Salvador. We are Located in Jiquilisco Bay, the largest Bay in El Salvador. Make Barillas Marina Club your headquarters in Central America and experience the difference that makes us a preferred destination.

[www.barillasmarina.com](http://www.barillasmarina.com)  
(503) 2675-1131 • [info@barillasmarina.com](mailto:info@barillasmarina.com)

*Welcome to Mazatlan...*



*Marina El Cid style!*

**A CRUISER'S PARADISE IN THE HEART OF MEXICO'S LUSH TROPICAL COASTLINE AND BEAUTIFUL ISLANDS**

*Complete, Modern Amenities, Including Marina-Wide High Speed Wireless Internet Connections!*



[www.elcid.com](http://www.elcid.com)  
011-52 (669) 916-3468  
[gcevallos@elcid.com.mx](mailto:gcevallos@elcid.com.mx)

*The Cruiser's Home in Mexico*

Goodlander of the Virgin Islands-based Hughes 38 **Wild Card** in his holiday newsletter. "It had been 2.5 years since we last hauled, so it was a big, barnacle-busting job. Rebek treated our boat like a Fabergé egg. We slapped on \$1,400 worth of paint, and managed to relaunch in 14 days — despite the fact that it rained each and every day, often several times a day. Once afloat, we returned to Kuah to help Amanda, a Malay friend, get her new coffeehouse off the ground. I played guitar there almost every night for weeks. Amazingly, I was joined by Nashville songwriter Gene Nelson, the country picker who wrote *18 Wheels and a Dozen Roses* — and seven other million sellers! Gene is circumnavigating with his two teenage sons aboard their C&C 48 **Emelia**. We made dozens of local friends in the year we based out of Malaysia, and went to lots of weddings, grand openings and Muslim parties. The Malay people are lovely — very honest and generous. We also bumped into Germans Jurgen Kanter and Sabine Merz of **Rockall**, who had been captured by

Somali pirates and held for ransom for 52 days. They were constantly threatened with death — and worse — until someone paid \$2.5 million for their release. They never learned who put up the money. **Rockall** was completely looted — the engine, sails, boom — so nothing was left after the pirates and police got through stripping her. The thing that drove Jurgen the craziest was that the pirates were so primitive that they didn't use the stove for cooking. Instead, they just built a fire on deck and fed it with bits of varnished mahogany that had been crow-barred from her interior. As for us, we're soon to be sailing **Wild Card** across the 3,000-mile wide Indian Ocean to Oman, getting ready to — pirates permit-



**Now lazily circumnavigating for the second time, Cap'n Fatty has made a career out of profiling colorful nautical characters.**

ting — make a run up the Red Sea. Fatty, an old friend who writes frequently for *Cruising World* magazine, has a new book out called *All At Sea Yarns*, which he says "contains some of the weirdest, most twisted of my bizarre writing." That's really saying something, so you should check it out.

## CRUISERS RALLY TO EL SALVADOR

**1st PRIZE - \$1000**

+ 1 week at Bahia del Sol Marina

**2nd PRIZE - \$500**

+ 2 nights at Bahia del Sol Hotel

**3rd PRIZE - \$300**

Prizes by drawing -  
More prizes check rally blog

Entrance Coordinates: 13d 15.25N - 088d 54.4W

### SPONSORS

El Salvador Ministry of Tourism

Hotel Bahia del Sol Plus: Tourin Travel Tours, ES; Cruising Ports, USA; Island Marine, ES; Marina Riviera Nayarit, Mx; Marinsa Marine, ES; Mexicolder, Mx; Quantum Sails, USA; Restaurant Acajulta, ES; Restaurant Mary Sol, ES; Sarana's Cruising Guides, USA; West Marine, USA; Hotel Los Almendros, ES; San Diego Marine Exchange, USA; Barracuda Marine, ES

### REGISTER FREE

by **May 5, 2010**

at an El Salvador Seminar or

by email: [ELSALVADORRALLY@AOL.COM](mailto:ELSALVADORRALLY@AOL.COM)

(subject line: Rally Registration)



The spectacular rally destination of Bahia del Sol, **El Salvador**, offers a relaxing atmosphere where cruisers can enjoy the "Bahia" and safely leave their boats while they travel inland **Central America**.

Open to all cruising boats, motorized or sail. Participants must arrive at Bahia del Sol between March 15 and May 10, 2010. Upon arrival each boat will receive a gift package. A rally awards ceremony will be held May 15, 2010 hosted by the rally organizers followed by a cruisers party.

[ELSALVADORRALLY.BLOGSPOT.COM](http://ELSALVADORRALLY.BLOGSPOT.COM)  
for rules and instructions

**WARNING** for cruisers leaving from Mexico: Weather in the Gulf of Tehuantepec is a serious issue and you must obtain a reliable forecast before crossing. Marina Chahue in Huatulco is a good source. It is 450 miles from Huatulco to Bahia del Sol, El Salvador.

# CHANGES

"As of early December, 23 boats have signed up for the first ever **El Salvador Rally**, which is a cruising rally from Mexico to El Salvador and 'The Forgotten Middle'," report organizers Bill Yeargan and Jean Strain of the Honolulu-based Irwin 37 **Mita Kuuluu**. "We had an informational seminar at the La Cruz Marina in early December, and will have another one on January 27 at the Vallarta YC at Paradise Village in Nuevo Vallarta. If anyone is interested, please stop by or visit us at [elsalvadorrally@aol.com](mailto:elsalvadorrally@aol.com)."

"Like a lot of boat owners on Banderas Bay, I was about to take my boat 200 miles up to Mazatlan and the highly-regarded **Total Yacht Services** at the Singlar yard for a bottom job," writes Thomas Lilienthal of the La Cruz-based Oceanis 41 **Dream Seeker**. "But after comparing prices and talking to folks who have recently hauled at the new **Nayarit Riviera Marina Ship Yard** in La Cruz, I decided to give them a chance. I came away very pleased, because the haul-out was \$300 less than it would have been in Mazatlan, and because the work was of high quality and done on schedule. They even did extra tasks



LATITUDE/NICK

*"I can't believe we saved \$5,800 on the keel," says a happy Huggy, standing in front of 'Pipe Dream' at the Nayarit Riviera Ship Yard.*

that I wasn't charged for, things I know I would have paid dearly for back in the States. Perhaps best of all, co-owner and manager John Gerber introduced himself to me, pointed out his office,

and told me that if I saw any work being done below my standards, I was to get him so he could have his workers rectify the situation. Gerber was also there when *Dream Seeker* was splashed, and told me that if I was unhappy with any of the work over the next few weeks, to come back and he'd see that it was taken care of. Having owned boats for over 25 years, and spent a lot of money in a lot of yards, I found it to be a unique and wonderful experience."

When the Nayarit Riviera Marina boat yard opened a little more than a year ago, there was a lot of grousing about the prices being higher — much higher — than in the States. Therefore, a lot of boat owners would make the 400-mile round-trip to Mazatlan, where Total Yacht Services had indeed earned an excellent reputation. But Gerber has really seemed to turn things around. Huggy, the BMW aboard Scott Piper's Miami-based J/160 **Pipe Dream**, hauled there last month, and told us an interesting story. "We'd gotten some chain wrapped around the keel while in Thailand, so when we hauled at Vancouver last sum-

Come to Mexico and repair your boat at

# OPEQUIMAR

MARINE CENTER CENTRO MARINO

Puerto Vallarta

88-ton (max) Travelift!  
Length to 100'  
Width to 23'

México AEROTRON www.aerotron.com RIVIERA NAYARIT PUERTO VALLARTA Where Mexico Comes to Life

[www.opequimar.com](http://www.opequimar.com)

fuel dock • full service boatyard • brokerage • 88-ton Travelift

Your secret paradise...

in Nicaragua

Located in a beautiful sheltered lagoon on the north Pacific coast of Nicaragua, Marina Puesta del Sol is your premier cruising destination in Central America.

Marina Puesta del Sol RESORT

Aserradores, Nicaragua ♦ 011 (from US and Canada) 505-880-0019  
mpuestadelsol@yahoo.com ♦ [www.marinapuestadelsol.com](http://www.marinapuestadelsol.com) ♦ USA 408-588-0017

mer, we asked for a quote to do some repairs on the leading and trailing edges. They wanted \$6,000, which seemed a little too steep. Well, when we hauled at Nayarit, they happily did the work for just \$200. That's a savings of \$5,800!"

We want to double emphasize that we're not recommending any boatyard over any other, but are simply reporting that we can't remember ever hearing so many boat owners being so pleased with the prices and work being done on their boats. This is true not just in Mexico, but also in the United States. In fact, in some cases yards here in the States have underbid those south of the border. As a result, we recommend that everyone follow the advice of Motown singer Smokey Robinson, who sang, "You'd better shop around."

Speaking of the **Vallarta YC**, they held their 10th annual **Chili Cook-Off** on December 5th, the day after the Banderas Bay Blast, which they co-sponsor. There was a massive turnout, which is a great thing, because all but a few pesos of the money collected — \$56,080 pesos — goes to the nonprofit Families of the

Dump. The name might cause you to laugh, but it's no joke, as there are families — and even single kids — who are so poor they have to scrape out an existence from the Puerto Vallarta dump. FAD uses the cookoff proceeds to try to address the many physical, spiritual, medical, emotional and educational needs of the people who live in the dump. For more information, Google the Vallarta YC web site.

Speaking of charity events in Mexico, if you're anywhere near Zihua February 2-7, you don't want to miss the 9th Annual **Zihua SailFest**, perhaps the biggest cruiser fund-raiser of all in Mexico. Last year \$640,000 pesos — about \$50,000 U.S. — was raised, with \$20,000 U.S. more chipped in by Rotary International. Six hundred very



*With ravishing Maira Muñoz and Jennifer Wright of La Riviera ladling out the chili, it was impossible — fortunately — to stop giving to FAD.*

deserving kids in nine schools were the beneficiaries. Cruiser volunteers and participants are the life blood of this wonderful event, so please participate if you can.



Looking a little farther down the road, the Club Cruceros' **La Paz Bay Fest** will

## Ixtapa



## Marina Ixtapa



-  The biggest marina in Latin America
-  621 slips from 40 to 140 feet length
-  Ship yard with 110-ton Travel Lift

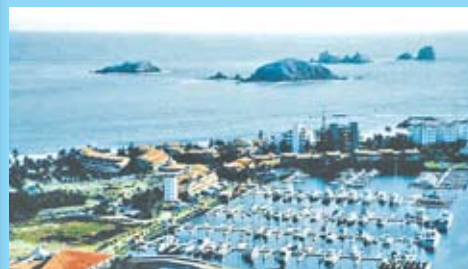

*The most spectacular  
cruise destination  
in Mexico!*

N 17°39.44 • W 101°37.12  
Chart your course for Ixtapa.

Visit:

[www.marinaixtapa.com](http://www.marinaixtapa.com)

Tel: 011-52-755-55-3-21-80

011-52-755-55-3-02-22

Fax: 011-52-755-55-3-21-80

Email:

[ezuniga@marinaixtapa.com](mailto:ezuniga@marinaixtapa.com)

# CHANGES

be held April 8-11, **Sea of Cortez Sailing Week** on April 15-22, and **Loreto Fest** April 30-May 2. Of these, Loreto Fest is the biggest, Sea of Cortez Sailing Week has by far the most sailing, and La Paz Bay Fest is easiest to get to. All of them are fund-raisers for deserving local charities.

If you're going to be cruising or chartering in the **Eastern Caribbean** this winter, there is a huge slate of events from Puerto Rico down to Trinidad — although to our knowledge none of them are for charities. If we had to pick what we thought were the top events, they would be, in chronological order, the following: March 4-7, **30th Heineken Regatta** in St. Martin; March 25-28, the **St. Barth Bucket** for boats over 100 feet; April 1-5, the **Bequia Easter Regatta**; April 2-5, the **B.V.I. Spring Regatta**; April 6-11, **Les Voiles de Saint Barth**; April 15-20, the **Antigua Classic Regatta**; April 24-May 3, **Antigua Sailing Week**; and May 7-9, the **Anguilla Regatta**. For the record, participants in Caribbean regattas drink about a case more beer or a quart more rum, per



AMY MICHELE

*So close yet so far. According to unconfirmed reports, 'Melody' was lost after running out of fuel near the harbor at Santa Rosalia.*

night, than do participants in sailing events in Mexico.

"On the Tuesday before Thanksgiving, David David's sloop **Melody** went on the rocks, apparently as a result of

running out of fuel while about to enter Marina Santa Rosalia," reports Patrick Martin of the Long Beach-based Crealock 34 **Amy Michele**. "The boat was holed above and below the waterline, with a 3-ft diameter hole beneath the waterline. I'm told that the Mexican Navy stationed guards by the boat to make sure she wasn't stripped, and that the next day workers from the marina came down to help David salvage everything the could be salvaged. They managed to get the winches, fittings, boom, sails and all his personal stuff. In fact, they got pretty much everything but the hull and mast. A very experienced sailor, David was naturally distraught due to the loss, but the last I heard, he'd taken off to Guaymas to look at boats."

"Time is a funny thing," write Wayne Meretsky and Neria Brewerton of Alameda-based S&S 47 **Moonduster**, currently at Nanuya Resort, Blue Lagoon, Yasawa Islands, Fiji. "When we were in Neiafu, Tonga, I asked someone the time, and he replied, 'It's 2009.' I thought that was clever. After all, how much

## MARINA REAL

SAN CARLOS, SONORA, MEXICO

### IN THE SEA OF CORTEZ

Located on the Mexican mainland near Guaymas and San Carlos, 265 miles south of Nogales, Arizona.

- 350 slip marina • 20 & 30 amps electrical service
- 24-hour security patrol
- Fuel dock with gasoline/diesel
- Restrooms & showers
- Web email • Fax/copy service
- Port entry clearance
- Book exchange • Video loan library
- Ice & bottled water
- Wet storage for summer months (low prices)

**Now Offering:**  
Haulouts, Dry Storage & Service Yard



marina Real

Phone/fax 011-52-622-2270011  
Call on VHF #16 when in area  
email: [marinareal@prodigy.net.mx](mailto:marinareal@prodigy.net.mx)

Visit our website:  
[www.marinareal.bravehost.com](http://www.marinareal.bravehost.com)

## Ventura Harbor Boatyard, Inc.

*Located halfway between San Francisco and San Diego*



OPEN  
SATURDAYS

Two Travelifts  
Haul-outs to  
160 Tons  
Painting  
Rigging  
Machining  
Welding  
Electrical  
Sandblasting  
Woodwork  
Chandlery  
Custom  
Stainless

1415 Spinnaker Drive, Ventura, CA 93001  
(805) 654-1433 • [www.vhby.com](http://www.vhby.com)



precision is really required? Enroute to Fiji, we changed the clocks by one hour to adjust for the change in longitude — one hour per 15 degrees — but we haven't really been maintaining much of a schedule. We missed dessert at the resort restaurant last night. In fact, the waiter looked rather miffed at us as he informed us that the kitchen had closed at 9 p.m. It didn't make sense to us, and when we got back to *Moonduster*, it was our turn to be a little miffed, because the clock said 8:30 p.m. And so today we were shocked when, during our morning hike, we encountered a woman who was convinced that it was 12:15 p.m. That was clearly impossible because we'd left our boat just an hour before at 10 a.m., and Neria had a massage appointment at noon. How could this be? In a word, Daylight Saving Time. All right, that's three words, but you get the point. After reconstructing the facts, we found that we've been on the wrong time every since we arrived in Fiji 2½ weeks ago! And on reconsidering a number of things, that certainly explains why the town of

Savusavu closed up so early at night and started so early in the morning. And why our guide for our cave adventure the other day seemed to be waiting so impatiently for us. In fact, all the pieces are fitting together a bit better now — except for that missing hour that we won't find for another six months or so."

"The first sail of every season is always the worst," writes Marc Hachey of the Auburn-based Peterson 44 **Sea Angel**, who is starting something like his sixth straight winter in the Caribbean. "Part of it is because it's a long overnighter, from Trinidad, where I keep my boat in the summer, to Grenada, where I start working my way north up the chain. I got off the dock late as I decided I would leave on — the heck with superstition



**When Wayne and Neria attended a BBQ in Tonga, the pig didn't know if it was Daylight Saving Time or not, only that his time had come.**

— Friday morning. Then the weather forecast changed from Thursday p.m. to Friday a.m., and there was supposedly going to be a very small weather window where the wind and seas were down for a short period. Yeah, right! So I worked nonstop Friday preparing to go. And I do mean nonstop, as I ate a peanut butter sandwich for lunch one bite at a time

## Your Boatyard in the Heart of Paradise



*Large, fenced, secure dry storage area*

**Tahiti Customs policy has changed!**  
Foreign Flag vessels can stay on dry storage in our yard for up to 12 months out of 24.

### Our Services |

#### HAULOUT

- Marine Travelift 25 tons
- Marine railway 120 tons
- Storage in adjustable steel cradles
- Fenced Yard

#### PAINTING

- Topsides, hull, bottom, varnish
- Brush, roller, spray

#### MECHANICAL WORK

- Inboard, outboard, diesel, gas
- All brands

#### REPAIRS

- Electrical repairs
- Refrigeration installation & repair
- Fiberglass & woodwork
- Welding, steel, stainless, aluminum

#### SAIL LOFT

- Sail repairs, biminis, dodgers, covers

#### STORE

- International, Pettit, Epiglass, Devoe
- Spares
- Fill U.S. gas cylinders

#### DO-IT-YOURSELFERS WELCOME!

*BoatUS Cooperating Marina*



*Professional boatyard in the heart of Paradise*



A Subsidiary of  
The Moorings Yacht Charter, Ltd.

*Raiatea Carenage will make sure  
paradise is everything you expected.*

*Call, write, or sail in . . . we're here to serve you.*

**B.P. 1111 Uturoa Raiatea 98 735 Polynésie Française**

**Tel: (689) 600-545 ~ Fax: (689) 600-546 ~ VHF 68**

**Web site: <http://www.raiatea.com/carenage> ~ email: [raiatacarenage@mail.pf](mailto:raiatacarenage@mail.pf)**

# CHANGES

while working on other things. By the time I cleared Immigration and Customs and got back to my boat, it was 4:30 p.m. and I still had to stow my shore-power cord and hose on the dock, and various items on deck and down below. An hour later I was almost ready to depart, and already an hour behind the new schedule. Naturally a big black cloud and rain started heading my way, and at a time when the rain is usually over for the day. So I delayed my departure a few more minutes before starting the engine and asking the Russian guy next to me — who didn't understand one word of English — to move his docklines off the top of mine so I could get going. By then the sun was down and it was darker than normal because of the 99% cloud cover. My plan had been to at least get out through the Boca, a relatively narrow passage between Trinidad and an adjacent island, and out into the open ocean before dark. Well, it was already dark, and I still had stuff to do on the



**When it comes to the 'cost of cruising', Mexico still stacks up well against the competition. At a new and clean roadside restaurant near Nuevo Vallarta, \$3.50 got a delicious meal like this, plus a soup starter and a jug of fruit juice. But our favorite remains the 75-cent street tacos.**

boat before casting off from Chaguramus Bay. I still didn't have my GPS working with my laptop software, so I had to head out in the dark, navigating by memory

alone. I remembered there is a shoal sticking out from a point where the last turn is made on approach to the Boca, so I made sure that I gave it plenty of room. I had wanted to raise my mainsail in the flat and protected water of the bay, but I didn't have time because I was too busy clearing the foredeck. Well, after working hard for 36 hours, I got the hook down in the flatwater of Tyrell Bay, jumped into the refreshing sea and took a freshwater shower. After being covered in salt all night, the sweet water felt so soooooo good. And I'm getting free WiFi Internet access. After I catch up on my sleep and the weather clears in a few days, I'll head on up to Bequia for Christmas. Another season in the Caribbean has officially begun for me, and it feels so great to be here!"

Happy New Year to everyone! Here's hoping that **2010** is your best cruising year ever.

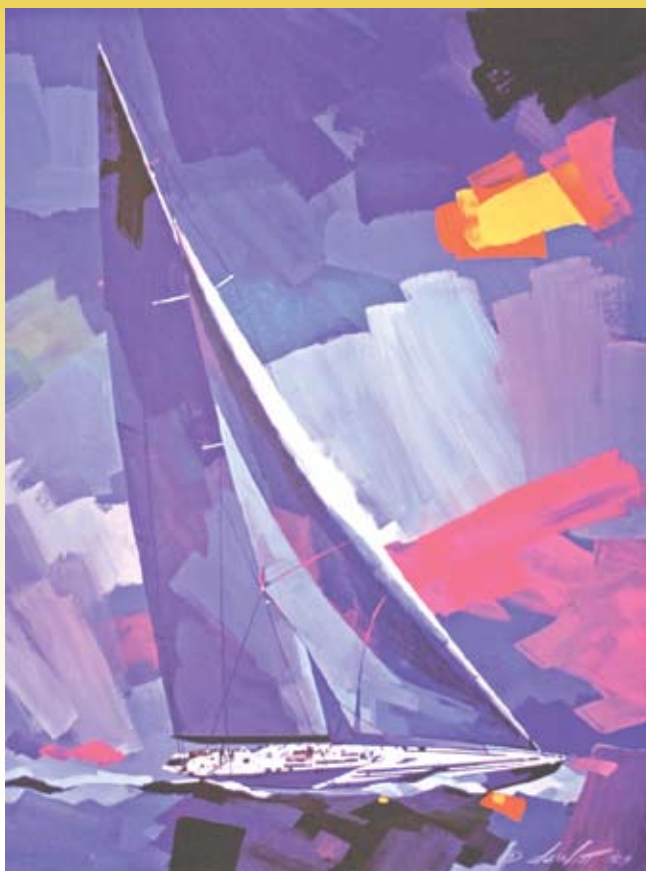

# deWitt

**Announcing  
Point Richmond Art Collective  
at DeWitt Gallery & Framing**

*Come see all the Gallery has to offer  
now with ten artists showing their wares!*

RESOLVED:

"I will bring more beauty and art  
into my life in 2010."

**DeWitt Art Gallery & Framing**

121 Park Place, Point Richmond, CA 94801

**(510) 236-1401 ☎ (800) 758-4291**

**[www.jimdewitt.com](http://www.jimdewitt.com) ☎ [www.dewittgalleryandframing.com](http://www.dewittgalleryandframing.com)**

Tuesday-Saturday 11:00-7:00 ☎ Sunday 9:30-5:30

# GOLDEN STATE DIESEL MARINE

*PARTS*  
YANMAR • UNIVERSAL • WESTERBEKE  
PERKINS • ISUZU • PATHFINDER • ATOMIC 4  
*SERVICE*  
DIESEL ENGINES

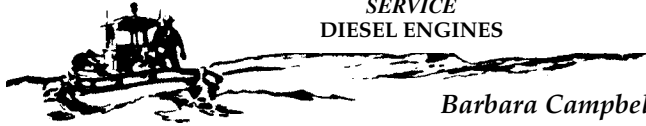

*Barbara Campbell*

351 EMBARCADERO  
OAKLAND, CA 94606

**(510) 465-1093**

*weatherguy.com*

**Worldwide Marine Forecasts**  
**Cruising, Racing & Commercial**  
Packages Starting at \$65.00 USD

(866) 882-WXGY (9949) toll free  
(808) 291-WXGY (Mobile)  
(808) 254-2525 (Office)  
(808) 443-0889 (Fax)



970 N Kalaheo Ave  
Suite C-104  
Kailua, Hawaii 96734  
info@weatherguy.com

[www.weatherguy.com](http://www.weatherguy.com)



## \$95K Ready to Sail

LOA	LWL	Beam	Draft	Displ.	Spar
27' 10"	25' 0"	7' 6"	6' 0"	4,073	Carbon

Introducing the LS-30 performance daysailer from  
The Landing School. Only two available annually.

[landingschoolboats.com](http://landingschoolboats.com)

207-985-7976

97% First Time Pass Rate • 100% Satisfied Students

**MARITIME INSTITUTE**  
INCORPORATED



**Captain's  
License**

Our NEXT  
SAN RAFAEL  
Class begins  
March 30th

Call Toll Free  
888-262-8020

[www.maritimeinstitute.com](http://www.maritimeinstitute.com)

**NEW! ONLINE COURSES**



**1,000 Used Sails**  
Listed at  
[minneysachtsurplus.com](http://minneysachtsurplus.com)

**We Buy Good Used Sails  
and Marine Equipment**

**MINNEY'S YACHT SURPLUS**

1500 Newport Bl., Costa Mesa, CA  
949-548-4192 • [minneys@aol.com](mailto:minneys@aol.com)

*"We keep boating affordable!"*

**VOLVO  
PENTA**

ENGINES • PARTS • SERVICE

We Ship  
Anywhere

**1-800-326-5135**

(415) 453-1001  
FAX: (415) 453-8460  
[www.helmutsmarine.com](http://www.helmutsmarine.com)  
619 Canal Street  
San Rafael, CA 94901

Happy  
New Year!  
- Helmut, Lisa &  
the Crew

**HELMUT'S**

**MARINE SERVICE INC**

AUTHORIZED POWER CENTER

**HAWAII**

**LONG TERM DRY STORAGE**

*Clear Customs at our dock*

**GENTRY'S  
KONA MARINA**

**HONOKOHAU HARBOR**

156°1'30" W  
19°40'20" N

TOLL FREE **888-458-7896**

[www.gentryskonamarina.com](http://www.gentryskonamarina.com)

The friendliest boatyard in Hawaii

Please read before submitting ad

# Classy CLASSIFIEDS

## Here's What To Do:

**Write your ad.** Indicate category. Remember price and contact info. We make final placement determination.

**Count the words.** Anything with a space before and after counts as one word. We will spell-check, abbreviate, edit, as necessary.

**Mail your ad** with check or money order, deliver to our office; **OR, for the best – and most exposure – of your classified ad...**

### Submit your ad safely online

with Visa, MasterCard or AmEx at:

**www.latitude38.com**

Ad will be posted online within two business days, appear in the next issue of the magazine, and remain online until the following issue is released.

## PERSONAL ADS

1-40 Words ..... \$40  
 41-80 Words ..... \$65  
 81-120 Words .... \$90  
 Photo ..... \$30

• Personal Advertising Only •  
 No business or promo ads except Non-Profit, Job Op, Business Op

**'Trying to Locate' Ads** are for those searching for lost boats/people – not shopping – and cost **\$10** for 20 words max

**FREE Online Ads** are for a private party selling a boat for less than \$1,000 – or gear totalling under \$1,000. (One per person; must list prices in ad.)

All ads will be set to fit *Latitude 38* standard • Re-Run Ads: Same price, same deadline

## BUSINESS ADS

**\$70** for 40 Words Max  
 • All promotional advertising •  
 1 boat per broker per issue  
 Logo OK, but no photos/reversals  
 No extra bold type • Max: 12 pt font  
 Artwork subject to editor approval.  
 Biz ads will not appear on website.

## DEADLINE

is **ALWAYS** the **18th at 5 pm**

for ad to appear in the next issue.

*Due to our short lead time, deadlines are very strict and include weekends & holidays.*

### Sorry, but...

- No ads accepted by phone
- No ads without payments
- No billing arrangements
- No verification of receipt
- We reserve the right to refuse poor quality photos or illegible ads.

*Latitude 38* 15 Locust Ave, Mill Valley, CA 94941 Questions? (415) 383-8200, ext 104 • class@latitude38.com

**WHAT'S IN A DEADLINE?** Our Classified Deadline has always been the 18th of the month, and it's still pretty much a brick wall if you want to get your ad into the magazine. But it's not so important anymore when it comes to getting exposure for your ad. With our new system, your ad gets posted to our website within a day or so of submission. Then it appears in the next issue of the magazine. So you're much better off if you submit or renew your ad early in the month. That way your ad begins to work for you immediately. There's no reason to wait for the last minute.

## 24 FEET & UNDER



**24-FT MELGES.** Alameda Boatyard. \$MAKE OFFER. Hot Deal! Must sell this month. Hull #87. Great PHRF boat. Performance, fast, easy to trailer. (Photo is sistership.) Contact Frank. (512) 750-5735 or cabosportsfrank@yahoo.com.



**24-FT MOORE, 8-BALL.** Fastest Moore 24 on the Bay, is fully tricked out and 'Easomized'. New sails, custom paint, very fast and ready to go out and win. Call to step aboard this 'turn-key' opportunity for one of the largest, most competitive and most fun fleets on the Bay. Call (510) 232-7245.

**22-FT SANTANA, \$1,800.** Excellent class jib and main with additional oversize spinnaker and 155% North jib. Recent bottom paint and rudder fairing. Bow and stern pulpits added. (415) 686-5256.

**J/24, 1978, \$9,800.** SF Bay 2007 Fleet champion. Fully faired. 2002 dual axle trailer; almost new North sails and backup set. Mast 2003, boom 2009, standing rigging 2008, 3.5hp outboard, carbon pole, running rigging, extras. See more at: <http://sites.google.com/site/j24forsale533>. Email [eww@berkeley.edu](mailto:eww@berkeley.edu).

**27-FT ANTRIM, 1996.** Point Richmond. \$35,000. K5, Hull #1. OD sport boat priced to move! Sail 15+ knots. Carbon mast, new trailer. Barely used Quantum main and jib, 3 kites, new running rigging, lots of extras. Email [robdkessel@yahoo.com](mailto:robdkessel@yahoo.com) or (415) 828-1203.



**26-FT CONTESSA, 1976.** Los Angeles. \$29,500. *Horizon* was bought and outfitted for the Singlehanded Transpac (SHTP) in 2008. She is just about completely redone with too much to mention here. Just a couple of things to wet your whistle: New diesel engine 2005. New radar 2008. New Monitor windvane 2008. New 2 part Urethane inside and out October 2009. Ready to go on SHTP 2010 or go cruising. For full specs and 20 pictures, go to [boats.com](http://boats.com) website, search for 'Contessa' and scroll down to my Contessa 26 that says, "For sale by private owner - Richard Hillman". That's me. [www.boats.com](http://www.boats.com). Call (714) 914-1451 or [captainrich1@sbcglobal.net](mailto:captainrich1@sbcglobal.net).

## 25 TO 28 FEET



**27-FT ERICSON, 1978.** Sausalito. \$11,000. Yanmar diesel, wheel, furling, autopilot, new hatches, all new rigging & lifelines, new head, new upholstery. Great singlehander or take the family. Well maintained and in excellent condition. See more at: [www.flickr.com/photos/29512960@N07/sets/72157622552854149](http://www.flickr.com/photos/29512960@N07/sets/72157622552854149). (510) 213-3586 or [cathouz@yahoo.com](mailto:cathouz@yahoo.com).

**28-FT ERICSON 28+, 1981.** Rio Vista. \$12,500/obo. Universal diesel, new fuel tank, North sails, new upholstery, clean, wheel steering, recently replaced lifelines. Email [stottonic@gmail.com](mailto:stottonic@gmail.com).

## DINGHIES, LIFERAFTS AND ROWBOATS

**12-FT ZODIAC FASTROLLER 380.** 1997. Sausalito. \$1,800/obo. Light weight with air floor and catamaran keels. 20" tubes. Comfortable, roomy, dry and fast. Up to 25hp. Has been in storage for ten years, little use. Highly visible red color. (415) 332-2500 or (415) 272-8350 or [flamingo480@gmail.com](mailto:flamingo480@gmail.com).

**CARIBE 10'2" RIB.** Inflatable dinghy, 1995. \$1,900. Fiberglass hull, hypalon tubes. Mercury 15hp two stroke motor, tank. Canvas cover, boat and motor lifting harnesses, aluminum oars, pump, seat, anchor. Runs great, stable, planes well and moves fast. (510) 219-9116.

Yacht Repair  
 Design / Consulting  
 Custom Interiors  
 Exterior Joinery



## STEVE'S MARINE WOODWORK

60 C Libertyship Way, Sausalito  
[jonessail@aol.com](mailto:jonessail@aol.com) • (415) 332-2500



## NOR-CAL COMPASS ADJUSTING

Magneuto™ System Exclusively  
 Boat Remains in Berth • Eliminates Deviation  
 Authorized Compass Repair • All Major Brands  
 Hal McCormack • Phone/Fax: (415) 892-7177

### CHART SAVINGS UP TO 76%

### HIGH DEFINITION PRINTS • 256 INCREDIBLE SHADES!

Worldwide • Sample Chart \$5.95 • Affordable E-Chart back-ups  
 Bellingham Chart Printers Division, TIDES END LTD., PO Box 397L, Shaw Island, WA 98286  
 800-643-3900 • fax: 360-468-3939 • [www.tidesend.com](http://www.tidesend.com) • [sales@tidesend.com](mailto:sales@tidesend.com)

## BOAT • LETTERING

[alphaboatsue@aol.com](mailto:alphaboatsue@aol.com) • (510) 599-1197 • [www.alphaboatgraphics.com](http://www.alphaboatgraphics.com)

Creative and durable lettering and artwork for your boat

**28-FT LYLE HESS-DESIGNED BRISTOL** Channel Cutter, San Rafael, CA. \$61,000. Built at Sam B. Morse Yard, Costa Mesa, CA. Never launched. GRP. Custom hardwood deck and house, bronze ports, new Saab diesel. Fully found, needs to be rigged. Includes trailer. (562) 899-0774.

**28-FT ALERION EXPRESS, 1999.** Richmond Yacht Club. \$65,000. Hull #135. Flag blue. Scheel keel, single cylinder Yanmar diesel, shaft drive, Hoyt jib boom. Head w/holding tank. 2-year-old main, original jib. New running rigging. (510) 215-7424 or hboat@yahoo.com.

## 29 TO 31 FEET

**30-FT TARTAN MARINE, 1971.** Berkeley Marina "F" dock. \$5,400/obo. Wonderful Bay sailing, with engine mounted just behind mast. Side galley model. Hull number 13. Atomic 4 not running and don't have the money to fix it. (510) 910-2886.



**30-FT FISHER PILOTHOUSE, \$69,000.** Heavily built in England to Lloyds' specs. Outstanding example continuously upgraded, amazingly well equipped, pristine condition. In fresh water last 5 years. Documented. Specs and many photos at website. You won't be disappointed. See more at: <http://fisher30forsale.blogspot.com>. Email [trigeorge@hotmail.com](mailto:trigeorge@hotmail.com) or (916) 505-3397.

**30-FT CORONADO, 1973.** Monterey. \$8,995. Comfortable cruiser. Atomic 30 4 cyl, Santa Cruz/UK Sails, Barient winches. 15 gal gas tank, head, holding tank, macerator pump, 2 batteries, Sony CD player, gimbaled stove. VHF, davits, 12V & manual bilge pumps. (831) 372-7245 or [capt\\_dutch@montereysailing.com](mailto:capt_dutch@montereysailing.com).

**INTERNET FRAUD.** Recently, we've been getting another tidal wave of reports of Internet scams, so we feel compelled to warn you once again about this unfortunate aspect of human nature. If somebody wants to buy your boat sight unseen, and suggests sending you a cashier's check for more than the asking price, trust your instincts. It is too good to be true. Usually they want you to cash the check and return the remainder to them for shipping costs. Then, much later, the bank informs you that the check was no good. We recommend that you don't even respond to the initial email inquiry. For more info on these cons, see: [www.craigslist.com/about/scams.html](http://www.craigslist.com/about/scams.html) Brave New World.



**NEWPORT 30 MKIII, 1980.** Marina Del Rey. \$12,000. Here is a perfect opportunity to get into a very nice Newport 30 for a very reasonable price. Well maintained by a knowledgeable owner, this boat would make a perfect first time keel boat and is perfect for daysailing and trips to Catalina Island. Owner is motivated and is looking forward to upgrading to a larger boat. Easy to singlehand! Wheel helm, autopilot, furling mainsail and furling jib make for ease of handling. New head, new dodger, new bottom paint, engine and hull well maintained by professionals. (323) 394-1413 or (323) 235-7638 or email [douglas\\_williams@williamsrecords.com](mailto:douglas_williams@williamsrecords.com).

**31-FT PACIFIC SEACRAFT MARIAH.** 1979. Redwood City. \$39,500. Bulletproof world cruiser. 3-cylinder Yanmar diesel installed 2008. Recent standing rigging. Gorgeous teak interior. 2 burner stove with oven. Isotherm refrigerator. Sept 2009 haul-out and survey. <http://sites.google.com/site/pacificseacraftmariah>. Email [nicholas.clinton@gmail.com](mailto:nicholas.clinton@gmail.com) or (510) 502-8901.



**30-FT CATALINA, 81.** San Rafael. \$20,000/obo. Clean. New: main and jib, shore power, fuel tank. Recent upgrades: standing-running rigging, lights, batteries, cushions, motor (A4). Wheel, dodger, roller furling, VHF, stereo, stern perches, stern skirt, bimini. Partnership possible. (530) 235-4908 or (530) 859-1090 or [barrshome@yahoo.com](mailto:barrshome@yahoo.com).



**30-FT FISHER/NORTHEASTER, 1976.** San Diego, CA. \$79,500. The aft cabin version of the famous British motorsailer Fisher yachts. New Yanmar, new North sails. She is absolutely Bristol inside and out. For photos and complete information see website. [www.will-shelton.com](http://www.will-shelton.com). (619) 616-9209 or [csdales@yahoo.com](mailto:csdales@yahoo.com).

**30-FT CAPE DORY CUTTER, 1984.** Tomales Bay. \$37,500. Well maintained. Recent E80 radar, VariProp, new upholstery/cushions. A sweet sailing boat and easy to singlehand. Lots of pictures (click to enlarge) at website. <http://cd-30.blogspot.com>. (510) 910-2099 or [mbritt@eyedocs.com](mailto:mbritt@eyedocs.com).



**30-FT WILDERNESS, CUSTOM, 1980.** Alameda Marina dry storage. \$15,000/obo. Great boat. Pac Cup '96, 20+ knots, good sails, dry sailed, new keel, jumper strut for masthead kites, new paint inside, new bottom paint. Been sitting, needs some new lines and rigging, then ready to go. Email [mgreatish@comcast.net](mailto:mgreatish@comcast.net).



**ISLANDER 30 MK II, 1971.** Treasure Island \$15,000. Meticulously restored sloop ready to sail. Comes with six bags of sails including two spinnakers. This boat is turnkey and needs nothing. More info at: [www.sailboatlistings.com/view/11663](http://www.sailboatlistings.com/view/11663). Email [stephan.sowash@gmail.com](mailto:stephan.sowash@gmail.com) or (415) 867-5085.

## 32 TO 35 FEET



**33-FT ALAJUELA, 1979.** Ventura, CA. \$38,000. Very good condition. Bigger than many 35's. Full sail inventory. Ready for coastal cruising! Engine in good condition. Hull in excellent condition. Ray Richards design which optimizes performance vs stability. (714) 732-9882 or email [Jablonce@bp.com](mailto:Jablonce@bp.com).

**35-FT SANTANA, 1982.** Tiburon. \$18,000. Great boat for SF bay, handles high winds well. Very good shape. Many upgrades to rigging, includes hard rigging and extra sails for racing. Engine runs great, overhauled in 2001. (415) 846-3589 or (415) 897-6311 or [Gooddots@aol.com](mailto:Gooddots@aol.com).

**35-FT ALUMINUM BREWER** Bluewater, 2005. Friday Harbor, Washington. \$288,000. Fully equipped cruising cutter, readied for 2009 transoceanic passage, but unexpected change in plans. Truly, all you need to add is food. Full information at website: [www.millieboat.com](http://www.millieboat.com). (360) 704-8003 or [millieboat@gmail.com](mailto:millieboat@gmail.com).



**32-FT BENETEAU 323, 2005.** Sausalito Yacht Harbor. \$84,900. Possible slip. Like-new condition. Finot design. Sleeps 6, Queen aft-bunk, full galley, new head, shower, engine under warranty. 32'10" LOA. Over \$15,000 upgrades: 116% and new 90% summer jib, Raymarine ST4000, 40 Wind/Speed/Depth, C80 networked chart plotter, GPS, Kato mounted radar, VHF, stereo, Strong mainsail track system, Gori 3-blade folding prop, StackPack, Acu-Gage dual tank monitor, new Frigoboat reefer, wired for auto bilge-pump, galvanic isolator, new Trinidad bottom, KKMI maintenance. (707) 544-7988 or [donholden@sbcglobal.net](mailto:donholden@sbcglobal.net).



**ERICSON 35 MK II, 1970.** Long Beach. \$19,950/obo. Mexico/Hawaii ready. Skillfully refitted, windlass, custom double roller, 3 anchors, furling, 6 sails, refrigerator, weather skirts, new cushions, rigging, water heater, head, fuel, water tanks, wiring, plumbing. (562) 714-2455 or [tikkibill@gmail.com](mailto:tikkibill@gmail.com).

**32-FT ARIES, 1984.** Sausalito. \$28,500. Stout offshore cruiser. New mainsail from Hood in Sausalito. Roller furling jib. Wind generator. Lots of ground tackle. Fun boat to sail. Transferable downwind slip. [www.flickr.com/photos/zrl/sets/72157622805588990](http://www.flickr.com/photos/zrl/sets/72157622805588990). Call (415) 867-1040 or [nodandsmile@yahoo.com](mailto:nodandsmile@yahoo.com).

**34-FT SAN JUAN, 1984.** \$39,000. Fast comfortable, blue water cruiser, excellent condition. 6' headroom, galley, sleeps six, rod rigging. Roller furling headsail, 150% genoa, main, working jib, in good condition. 3GMD Yanmar, Achilles dinghy, large bimini. Price reduced. (510) 420-8956 or [nino@access-print.com](mailto:nino@access-print.com).



## WOODRUM MARINE

Specializing in custom interior cabinetry, tables, cabinets, countertops, cabinsoles. For power or sail.

**CARPENTRY**  
Mobile cabinet shop  
Contact Lon Woodrum at:  
**415-420-5970**  
[www.woodrummarine.com](http://www.woodrummarine.com)

## All-MARINE Electronics & Electrical

◆ System Design ◆ Troubleshooting / Repair ◆ AC & DC ◆ Quality Installation ◆ Licensed & Insured ◆  
◆ Radio & RADAR ◆ Antennas & Mastwork ◆ Integrated Navigation Systems ◆ Auto Pilots ◆  
◆ Battery Monitoring Systems ◆ Alternators, Regulators ◆ Solar ◆

Alameda, CA ◆ (510) 326-7821

**Jack D. Scullion**  
Yacht Services  
[jdscyachts@att.net](mailto:jdscyachts@att.net)  
(510) 919-0001

Rigging  
Electronics  
Troubleshooting  
Electrical Installations  
We Gladly Install Gear You Provide

**NEILPRYDE**



**MARINE SURVEYS by Captain Alan Hugenot**  
Naval Architect • Yacht Delivery Skipper  
Accredited Marine Surveyor (SAMS)  
Bay or Delta • No Travel Charges • MC / VISA / AmEx  
[alan@captainhugenot.com](mailto:alan@captainhugenot.com) • (415) 531-6172

We are always  
looking out for you!

American Yacht Insurance for boats over  
26 feet. We provide cover for any flag  
registration or  
navigation.



USA09037 www.pqhhd.de

**PANTAENIUS**  
American Yacht Insurance

Germany • Great Britain • Monaco  
Denmark • Austria • Spain • Croatia  
Sweden • USA\*

500 Mamaroneck Avenue Suite 318  
Harrison, NY 10528  
Phone (914) 381-2066

Newport Shipyard  
One Washington Street  
Newport, RI 02840  
Phone (401) 619-1499

www.pantaenius.com

\*Pantaenius America Ltd. is a licensed insurance agent licensed  
in all 50 states. It is an independent corporation incorporated  
under the laws of New York and is a separate and distinct entity  
from any entity of the Pantaenius Group.

## QUALITY CRUISING SAILS FOR LESS!

**LEE  
SAILS**



**MAINSAILS  
MIZZENS  
STAYSAILS  
HEADSAILS  
SPINNAKERS  
SAILCOVERS  
STRONGTRACK**

(510) 523-3337 • leesailsnc@yahoo.com

2021 Alaska Packer Pl. • Grand Marina • Alameda, CA 94501

**SAILMAKER TO THE WORLD**

## KATADYN SURVIVOR 35 WATERMAKER

The Survivor is a must for all sea-going vessels and is the most widely used emergency desalinator. It is used by the U.S. and international forces. It is able to produce 4.5 liters of drinkable water per hour. These are new U.S. government surplus.

Prices range from **\$400 to \$950**.  
Compare to factory new price: \$1,995.

For more information or  
to place an order, please  
call one of our sales reps.

In the U.S.: (800) 417-2279

Outside the U.S.: (717) 896-9110



## MARINE ENGINE CO.

**WESTERBEKE**

**Universal**  
DIESEL MARINE ENGINES

**BETA MARINE**

LICENSED DEALER FOR ABOVE

PERKINS • YANMAR • ATOMIC 4 • VOLVO

### CALL NOW FOR LOW ENGINE QUOTES

- Engine Sales, Service and Parts
- Engine Repowering and Rebuilding
- Complete Marine Engine Service

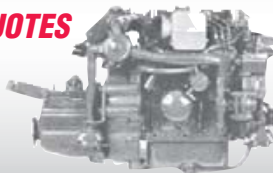

**(415) 332-0455**



**35-FT J/109, 2004.** Sausalito. \$185,000. Fast, fun, mint condition racer/cruiser singlehand or with crew. 1st 2008 J/109 Division, 1st 2009 J-Fest Division, 3rd PHRF (72 rating). Quantum Kevlar racing and Dacron cruising sails (2 mains, 2 jibs), 2 asymmetric spinnakers, new rigging, Spectra lines. B&G instruments, VHF radio, GPS, Yanmar diesel, 29 hp, excellent condition. Doubles as performance cruiser with roller furling, all rigging led aft, sleeps 6+ with full galley, head, shower, hot/cold water, fridge. Ready to race one-design, Pac Cup, PHRF or cruise oceans SF Bay and Delta in comfort, style and performance. Must sell. (415) 717-3664 or ahoy@earthlink.net.

**33-FT STEEL SLOOP, 2006.** Lowrie, San Rafael. \$52,000. Custom designed and built. 28hp Beta diesel, monitor vane, Hogan full batten main and genoa, Lavac head, Raytheon radar/GPS, extensive ground tackle, stainless steel galley, Shipmate stove/oven. Lines plan, pics, survey on request. Call (707) 895-2813 or derwinski@pacific.net.

**32-FT PEARSON RACER/CRUISER.** 1979. Alameda. \$23,000/obo. Easily singlehanded Bill Shaw sloop. Featured in August 2007 *Practical Sailor*. 1250 hours on original M-15 Universal diesel. Gear (vintage '95): Autopilot, digital depth finder and gauge, Harken furler, Navtek backstay adjuster, Hall Spars QuikVang, Furuno radar, 25-watt marine radio. New: 19-gallon aluminum fuel tank and electric fuel pump (2002), 2 batteries (2006). Documentation: all original manuals, '95 survey, maintenance, diving, haul records since my '95 purchase. (510) 525-2754.

### 36 TO 39 FEET



**37-FT ENDEAVOUR, 1981.** Wilmington, CA. \$40,000. Excellent liveaboard with beautiful teak interior. Private owner's cabin with double berth, huge salon, hanging lockers and drawers galore. 6'4" head room, new upholstery, canvas and cosmetics in recent years. Easy to sail. (562) 706-4334 or sailfast6@verizon.net.

**39-FTYORKTOWN, CENTER COCKPIT.** 1980. Richmond. \$26,000. Full bed in aft cabin, V-berth, CNG gas stove/oven, microwave, refrigerator, freezer, ice maker, VHF, radar, GPS, depth finder, 50hp diesel, electric windlass, electric head, separate shower. Great liveaboard. Call (209) 743-6275 or vik@inreach.com.



**38-FT KETTENBURG, 1956.** 3 Available. "Nice boat!", "Beautiful boat!", "Gorgeous boat!" heard many times from other boaters during every sail. Enjoy character, admiration, and fantastic sailing while sustaining the heritage. Details at: www.sailk38.com (916) 847-9064 or email steve@paradigmpilgrim.com.

**37-FT TARTAN, 1976.** Maryland. \$39,000. Good old boat for sail. Circumnavigator. Profurl, radar, SSB, solar, wind gen, '08 FB main, windlass, Raymarine 6002 autopilot, fridge, hot water, Freedom 10, Force 10 propane stove & heater. Centerboard missing, still sweet sailing. S&S design. Email jodefoe52@yahoo.com.

**36-FT PEARSON 365 KETCH, 1977.** Marina Village Yacht Harbor, Alameda. \$53,000/obo. Beautiful liveaboard. 40hp Westerbeke diesel. 3 new sails. 2005-Standing rigging, refrigeration, entertainment and electronic systems. Inflatable rigid bottom. Much more! (925) 457-4957 or sailonchap@yahoo.com.

**36-FT TRISBAL, 1981.** Sausalito Yacht Harbor. \$69,000. *Ta Mana* (aluminum hull, built in France) is a proven, comfortable world cruiser, loaded and in excellent condition with a recent haulout and bottom paint. A turn key Pacific Cup boat ready to go 2010. AIS, SSB, weatherfax, navigation computer, solar panel, windvane, Raymarine electronics, dodger, Yanmar 3GM30F, 3 blade folding prop. Sails in good to excellent condition. For details and pictures please check the website: www.getawayonthebay.com. (415) 272-5789 or skipper@getawayonthebay.com.

**37-FT CREALOCK, 1980.** Monterey. \$65,000. Cutter. Ballenger tabernacled mast. New Yanmar w/saildrive, radar, GPS, easy access to all systems, 70gal diesel, 3 watertight bulkheads. Not in yacht condition, needs finish work. Great little sailing ship. Price firm. Email ddatpbio@gmail.com.

**38-FT HUNTER 380, 2000.** Alameda Marina #350. \$96,500/obo. Radar, autopilot, Yanmar, chart plotter, electric winch, inverter, great shape. (503) 332-3334 or pbpme@hotmail.com.



**Fred Andersen Boat & Woodworks**

**Repair,  
Restoration &  
New Construction  
(510) 522-2705**

### SMALL AD, SMALL PRICES • RIGGING ONLY

Standing and running rigging, life lines, furling gear, winches, line, windlasses, travelers, wire and terminals, blocks, vangs, and much more.  
~ ~ ~ Problem solving and discount mail order are our specialties ~ ~ ~  
www.riggingonly.com • (508) 992-0434 • email: sail@riggingonly.com



**38-FT MORGAN CC, 1993.** San Diego, CA. \$75,000. Waterfront living at its best. There is no other option out there that allows oceanfront property at this type of price in San Diego. Morgan is an excellent sailboat and there are 5 currently for sale across the country. The prices range from 93k to 130k. This boat was listed for 110k and is now listed for \$75,000, well below the market rate. Take advantage of this for sale by owner/no broker offer today. Additionally this boat is located at Humphrey's by the Bay, which has live concerts from May - October for your viewing, listening and entertainment pleasure. See more: [www.humphreysconcerts.com](http://www.humphreysconcerts.com). Email [jdarrochdesign@yahoo.com](mailto:jdarrochdesign@yahoo.com) or (619) 243-6269.

**36-FT SABRE, 1998.** Berkeley. \$145,000. Have to sell her. Shallow draft keel. Blue hull and topsides painted 12/06. Standing rigging replaced 2/07. New autopilot 5/07. New mainsail 7/08. Furling jib and lightly used asymmetrical spinnaker. Call (925) 766-2205 or [dan@deltaexcavating.net](mailto:dan@deltaexcavating.net).



**37-FT EXPRESS, 1986.** Manchester, MA. \$60,000. Original owner. Yanmar 27hp diesel, upgraded rudder, Raymarine C-80 Navigation electronics, tiller pilot, SSB, Frigboat refrigerator, propane oven/stove, water heater, Xantrex 40 amp charger. Hauled out. Complete equipment list available. Call (603) 291-0280 or email [dickzd@hotmail.com](mailto:dickzd@hotmail.com).

**36-FT WILLIAM ATKIN SCHOONER.** 1977. \$30,000. 42' LOA. Traditional double ended ocean vessel. Heavy displacement, full keel composite construction. Marconi staysail rig for easy shorthanding. 30hp Yanmar diesel. Liveaboard or cruise. Message for photos and survey. Trades considered. (415) 265-0474.

## 40 TO 50 FEET

**42-FT VALIANT, \$295,000.** Never used. Never in salt water. Quantum sails, ProFurl on jib, autopilot, microwave, Westerbeke diesel. Boat is as new, location Valiant factory in Texas. Contact Dick May. (480) 513-7136 or [boatseller@aol.com](mailto:boatseller@aol.com).

**42-FT CATALINA, 1989.** Brisbane Marina, SF Bay Area. \$106,000. *Neener3* is a tri-cabin layout, with fin keel, cruising equipment, standing and running rigging upgrades since 2004. She is truly ready to go, in excellent condition, hauled, inspected and new bottom paint 12/2009. Call for details, equipment lists, photos and upgrades available on request. (831) 462-3013 eves or (831) 566-2857 anytime. Email [jpneener@comcast.net](mailto:jpneener@comcast.net).



**42-FT SPENCER, 1966.** Orcas Island, WA. \$42,000/obo. Aft cockpit sloop. Berthed in Seattle area. Solid fiberglass. Traditional lines, solid dodger, full keel. Cruiser. Warm teak interior, light and airy. Cruising couple moving ashore. If you are seriously considering a boat this size, don't think of paying more before checking this one out! Boat loaded w/gear. For safe, comfortable cruising or living aboard. See many current photos AND inventory list at website. <http://spencer42.shutterfly.com>. (360) 376-3838 or [spencer42seawind@yahoo.com](mailto:spencer42seawind@yahoo.com).

**44-FT KELLY-PETERSON, 1977.** \$140,000. Extraordinary. Purpose built for life in the tropics. Green power keeps systems running while others are running their motors. Refit 2008: solar, LED lights, big alternator, big batteries. Most beautiful boat in any anchorage: new canvas and new paint in Herreshoff-style palette. New rig, new electronics, new electrical system, new plumbing, custom features. Full set of sails, spinnaker and gear. Just hauled. Ha-Ha '08, Puddle Jump '09. Details at website. Contact Mike. [www.thinwolfadventures.com](http://www.thinwolfadventures.com). (509) 860-9614 or [wardski@thinwolfadventures.com](mailto:wardski@thinwolfadventures.com).



**43-FT PETERSON SERENDIPITY.** Lying San Carlos, MX. \$89,950/asking. Legendary offshore racer! A beautiful, fully equipped, high performance cruiser. Sail the buoys or the 'Far Reaches' on your dream cruise in safety and comfort. (925) 917-0913 [svlonestar@yahoo.com](mailto:svlonestar@yahoo.com).



**48-FT CHAPPELLE-DESIGNED.** Gaff-rigged wooden schooner, 1979. Sausalito. \$45,000. Laid in Marshall, planked in San Rafael and launched in 1979, *Henry Rusk* is a local celebrity. New canvas cover, deck prisms, prop. Recently hauled-out at Spaulding. Currently berthed in Sausalito. 3rd owner. [zserber@gmail.com](mailto:zserber@gmail.com).

**CAL 2-46, 1981.** San Rafael. \$89,500/obo. Baja Ha-Ha '08 vet. It can go again, but I can't. Must sell. 2 complete staterooms sleeps 5. 40 gal/day watermaker. Touchscreen GPS/radar, 272gal diesel, 200gal water. Dutchman main. Roller jib. Excellent condition. (415) 299-1087 or [millerpi@comcast.net](mailto:millerpi@comcast.net).



**40-FT PETERSON TWO-TONNER.** 1980. San Diego, CA. \$58,000/obo. This performance racer/cruiser sailed from San Diego to France in 2005 where she was totally refit: new Yanmar engine, hull/deck/mast paint job, bottom fairing, new head, rigging verification, new MaxProp, etc. After several regattas in France, and months cruising the Caribbean, she was sailed back to San Diego where upgrades continued: new refrigeration, new water heater, bottom job/deck paint, March 2009. Race in SoCal (PHRF 69) then cruise the islands in style. (619) 467-6369 [bruno.bomati@gmail.com](mailto:bruno.bomati@gmail.com).

**44-FT BENEYEAU 445, 1993.** St. Thomas, US Virgin Islands. \$129,000. Cruising ready performance cruiser/liveaboard located in the Virgin Islands. Watermaker, wind generator, solar, davits, AGM batteries, newer engine, navigation electronics, dinghy. [ansano.com/4sale](http://ansano.com/4sale) (340) 344-6262 [gil@ansano.com](mailto:gil@ansano.com).

**45-FT EXPLORER, 1978.** San Rafael, CA. \$109,000. Beautiful, lovingly maintained, center cockpit sloop/cutter. Constant upgrades past 15 years. Good performer, bright interior with 2 staterooms/heads. Yanmar 62 hp, LPU, radar. Haul and survey 2008. (415) 265-4418 or [david@winchmate.com](mailto:david@winchmate.com).



**50-FT FD-12, 1981.** Mexico. Unsinkable fiberglass pilothouse cutter. 3 private staterooms w/ fixed berths for 5-6. Spacious galley w/extraordinary views, great daylight, and generous counter space. Fully equipped turn-key blue-water cruiser. SoPac vet currently cruising Mexico. See website for contact details. [www.svdaydreamer.com](http://www.svdaydreamer.com).



**TARTAN 4400, 2003.** Channel Island Harbor. \$439,000. Hull #1, *Tartini Time* has been well cared for and optioned. Green LP hull, recent bottom paint. Call/email for options list and visit [youtube.com](http://youtube.com), search Tartan 4400, our actual boat! (530) 318-0730 [amgjohn@sbcglobal.net](mailto:amgjohn@sbcglobal.net).

**50-FT COLUMBIA, 1967.** Ventura. \$85,000. Legendary sloop designed by Bill Tripp. Comfortable liveaboard. Fast cruiser, sleeps six, dinette, galley with freezer, fridge, propane stove and oven, lots of extras. Perkins diesel. Haul out & survey August 2008. (805) 443-9206 or (805) 658-1415 [cconnally@islandpackers.com](mailto:cconnally@islandpackers.com).



**45-FT DOWNEAST, 1977.** Melbourne, Florida. \$79,000. Cruiser ready. Ketch rig sailboat. 4-236 Perkins 85hp, 300 gal water, 265 fuel, 14' beam, 6' draft, 6.5 headroom, 2 heads, 3 cabins. Dinghy davits, KISS generator, radar, phasor 6.5kw genset, inverter, GPS, Simrad autopilot, new main stackpack, newly painted and bottom survey. More info, check web page. She was in the 1998 Baja Ha-Ha. <http://prospectlearning.com/sorrento.html>. (702) 587-4790 or (702) 439-9768 or [taylorfran@hotmail.com](mailto:taylorfran@hotmail.com).



### STARBOARD YACHT DELIVERIES

Over 50,000 sea miles • Pacific, Caribbean, Atlantic  
USCG Master 100 GT STCW • Power & Sail

Rick Whiting • (415) 740-2924 • [captain\\_rick@sbcglobal.net](mailto:captain_rick@sbcglobal.net)



### SAVE \$\$\$ AND DO IT YOURSELF

Eco-Safe, Non-Bleach, Sail Cleaner.

New unique formulation thoroughly cleans and brightens whites and colors.  
Just soak for 24 hours and rinse off. \$24.95 to \$59.00 Guaranteed Results! Free Shipping!

888-908-9274 • Wash Safe Industries • [www.wash-safe.com](http://www.wash-safe.com)



### PROFESSIONAL DELIVERY CAPTAINS

San Diego based, USCG Master 100 GT. Sail and power. ASA-certified instructional deliveries. Pacific Mexico and Baja Bash specialists.

(619) 913-7834 • [davidhbrotherton@yahoo.com](mailto:davidhbrotherton@yahoo.com)

### COMPLETE MARINE WOODWORK

Design / Restoration • Expert European Craftsmanship • Interior / Exterior  
Repairs / Maintenance • Marine Windows & Frame Replacement  
Wood & Dry Rot Repairs • Varnish Work • Marine Painting  
References Available • Reasonable Rates • Call (415) 331-6718



## Save Your Aft!

Using one of our 1400+ patterns or your own pattern, let our craftsmen create a comfortable, durable, and stylish set of all-weather cushions for your cockpit. Find your custom, closed cell foam cushions at [www.bottomsiders.com](http://www.bottomsiders.com)!

# BottomSiders

**BottomSiders**  
2305 Bay Avenue  
Hoquiam, WA 98550

See us  
at the Seattle  
Boat Show  
1/29-2/6

Call Toll Free: (800) 438-0633  
[cushions@bottomsiders.com](mailto:cushions@bottomsiders.com)  
Fax: 360-533-4474

## ATLANTIC 57 CATAMARAN™



**THE ORIGINAL PILOTHOUSE CATAMARAN**

- o Designed for easy shorthanded cruising
- o Spectacular windward performance
- o Cored epoxy/glass/carbon construction

**CHRIS WHITE DESIGNS**

TEL: 508-636-6111

[www.chriswhitedesigns.com](http://www.chriswhitedesigns.com)

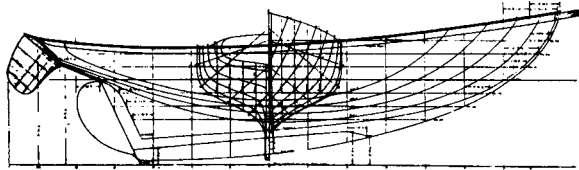

## MAKELA BOATWORKS

Family owned since 1948

**Wooden Boat Building • Repair and Restoration**

19280 South Harbor Drive • Fort Bragg, CA 95437

**(707) 964-3963**

email: [howard@makelaboatworks.com](mailto:howard@makelaboatworks.com) • [www.Makelaboatworks.com](http://www.Makelaboatworks.com)

## We care about sail care!



### San Francisco Service

773 Andersen Drive, San Rafael, CA 94901

T: 415-453-2142 M: 510-333-4644

Hours: 8-5 M-F, Sat. by appointment

**SAIL CARE ■ SAIL COVERS ■ YACHT COVERS ■ FLAGS ■ CRUISING PRODUCTS**



Faster by Design  
[www.northsails.com](http://www.northsails.com)

### 41-FT MORGAN CLASSIC MODEL.

1991. San Carlos, Mexico \$98,000. Primo condition. Equipped and ready to cruise. Center cockpit, great liveaboard, must see to appreciate roominess. Recent survey. See blog for equipment list and current photos. <http://sailboatvagari.blogspot.com>. [stanstreb@gmail.com](mailto:stanstreb@gmail.com) or (520) 825-7551.



### 42-FT HUNTER PASSAGE, 1993.

Puerto Vallarta, MX \$143,000. Cruiser/liveaboard center cockpit located in Mexico. Luger 6KW genset, Aquamarine 26 GPH watermaker, Achilles dinghy with new 2009 Nissan outboard, hard top bimini, Raymarine electronics. <http://summerwindhunter42.blogspot.com>. [wingandsail@yahoo.com](mailto:wingandsail@yahoo.com) or (928) 380-5502.

### 45-FT WAUQUIEZ CENTURION, 1992.

\$155,000. High quality, fast, performance world cruiser. Safely go anywhere. Passages with 200 mpd made good. We cruised the Caribbean and Pacific and now she must be sold. Solid FRP hull, masthead sloop, removable cutter stay, Harken furling, full-batten main, Windpilot servo-vane, swimstep transom, Lofrans electric windlass, dual-refrigeration, new Balmar alternator/digital charger, 1000w inverter, Icom SSB and VHF, Furuno radar, lots more. Photo and inventory available. Discount for quick closing. For more info: (808) 826-6050 or [tunes@aloha.net](mailto:tunes@aloha.net).

## 51 FEET & OVER



### 55-FT FIBER STEEL, 1980.

Sacramento, River View Marina. \$BEST OFFER. 72' OAL, 16' beam, F/C, 671 Main engine with 300 hrs. 15KW gen, 1100 gals. diesel, 500 gals. fresh water, ketch rig. New sails, 6'6" headroom, sleeps 8. Dinghy and new electronics, 385' 3/8 ht chain, 2000 lb windlass, 2 heads, shower, ice maker, 2 refrigerators/freezers. Great liveaboard with liveaboard slip. 7 minutes to downtown Sacto. Possible trades? Health forces sale. (916) 208-4141 or [seahawk2mexico@gmail.com](mailto:seahawk2mexico@gmail.com).

### 55-FT FIBER STEEL VALEO, 1980.

\$7,000/obo. Large production built ferro-cement motorsailer with pilothouse. 55-foot steel mast with furling gear for jib and main. Includes GM 3-71 marine engine/trans not installed. Hydraulic steering. Great liveaboard. (916) 718-1491 or [valeosea@aol.com](mailto:valeosea@aol.com).

### 51-FT MORGAN OUT ISLAND, 1976.

\$Best Offer. Large interior needs remodeling. Main and mizzen masts converted to Harken vertical furling for single handed ease. Perkins 85 hp diesel, no gen set. Hydraulic steering. Schaefer jib furling. (916) 718-1491 or [valeosea@aol.com](mailto:valeosea@aol.com).

## CLASSIC BOATS



### FRENCH CANAL BARGE.

Canal Du Midi, France. \$290,000/asking ...a fraction of her value. All reasonable offers considered. A wonderful turn of the century iron vessel, 100-ft built 1895. Converted to hotel barge in the 1970's. Refurbished in 1999 and 2000, and operated as a high end luxury charter vessel in southern France for over 10 years. Now ready for your adventure or use as apartment, etc. In excellent condition. British flag corporation. Divorce forces sale. Please call or email for further info, photos, etc. (415) 336-3367 or [nizzaneoz@aol.com](mailto:nizzaneoz@aol.com).

## MULTIHULLS



### 55-FT CATANA 531.

Newport Beach. \$549,000. Cruise the world in comfort, speed and safety. Excellent condition, many spares, sprit, 2004 Yanmars with sd40s, 8.5kw, 55-gph watermaker, stall shower, 5 electric winches, good sail inventory, many upgrades. 3 autopilots, SSB, radar, Inmarsat mini-M, MicroCommander controls, 12' Caribe with 25 hp, solar array, Profurl electric jib furler, computer with world charts, new Seal-and electric heads, inverter, much, much more. High quality. Prime Newport Beach mooring available. Call (949) 295-4116 or (949) 675-0617 or [jerrywoods37@hotmail.com](mailto:jerrywoods37@hotmail.com).

August Enterprises

## Marine Surveying and Consulting

Serving the Bay Area since 1995

**510-889-8850**

For the best – and most exposure – of your classified ad... submit your ad safely online at: [www.latitude38.com](http://www.latitude38.com).

Your ad will be posted online within two business days, appear in the next issue of the magazine, and remain online until the following issue is released.

*Clamy Ideal!*





**34-FT GEMINI 105, 2000.** Ventura Harbor. \$124,000. Well equipped—all standard features: 27hp diesel, pressure water, 110/engine water heater, VHF, Autohelm. Plus 110 air conditioning, 6 speaker stereo, TV, BBQ, DVD, windlass, 200' chain/200' rode and delta anchor, stern anchor, spinnaker w/sleeve, ATN storm sail, tri-lens, Furuno radar, Garmin 192C chartplotter, four 6V batteries, Link 20, battery isolator, lazy bag, Balmar voltage reg with high output alternator, all LED lights, Garhauer davits, all Coast Guard required equipment. (805) 217-3939 or dick.mahoney@gmail.com.

**28-FT CORSAIR 28CC HULL #201, 2005.** Sausalito, CA. \$92,500. Like-new, ready to race/cruise, AirDock, 9.9hp Honda, dodger, UK TapeDrive main, jib/roller furler, spinnaker, Porta-Potti, alcohol stove, safety gear, Garmin GPS, VHF radio, full boat cover. (415) 205-7335 or (415) 661-5223 or pascott@mac.com.



**48-FT CROWTHER CATAMARAN, 1991.** \$279,000. Java, Cutter-rigged, built in Australia 1991. Proven bluewater cruiser built for speed under sail. Sleeps 8 comfortably. New paint top to bottom. New mast, boom, oversized rigging 2005. Equipped for the tropics around the world with large awning/watercatcher. Solar, wind generator, HF radio, new VHF radio, sea anchor, drogue, 4 anchors. High bridgedeck clearance insures no pounding. Retractable centerboards for upwind performance. Solid handrails for safety. Free delivery. For specs and pictures email Evan Dill: revandill@yahoo.com.

**47-FT CATANA, 2001.** Puerto Vallarta. \$699,000. 472 Catana Caligo 2001, already in paradise. Price reduced on this fast, luxurious, easily sailed catamaran. One hull for owners, other hull pampers guests. Full amenities, see on www.Yachtworld.com or contact owner. S/V Moon and Stars. May consider real estate trade. cat47moon@yahoo.com.

**CATAMARAN DESIGNER SINCE 1957** has developed and tested a major design improvement for 30- to 40-ft cruising cats. Desire commercial builder on West Coast. Call Ralph. (831) 761-5969.



**55-FT 48 PASSENGER CATAMARAN.** 1978. San Francisco. \$129,000. You either buy the whole boat for \$129K or you can buy 50% of the boat for \$129K and I'll put \$100K back into the boat in the form of a FULL remodel and we'll own it together. This boat is a PROVEN money maker! US Coast Guard Certified to 48 passengers. Twin Diesel, 8kw generator. All in good order. Selling because of the economy. www.rendezvouscharters.com/searaven.htm. (415) 543-7333 or spinnaker.sailing@yahoo.com.

## POWER & HOUSEBOATS

**53-FT HATTERAS, 1970.** Berkeley. \$119,000. Flybridge motor yacht. New dishwasher, twin Cummins VT8-370M Turbo. 2500 hrs. Generator: EnTec Power Plant Model M4. Dinghy: Alliance 12' w 25hp Mercury. Liveaboard status possible. Must see to appreciate. (510) 725-9942 or tparfitt@yahoo.com.

**61-FT FIBERGLASS LASH BARGE.** 1975. Port of Sacramento. \$Best offer. Built by Northrop Corporation, CA. 61 foot by 31 foot with 14 foot sides, no top. Honeycomb construction. Empty weight 55 tons. Great for houseboat base or offshore office/storage. Owner retiring/shutting down business. (916) 718-1491 or valeosea@aol.com.

**20-FT SHAMROCK PILOTHOUSE, 1988.** Emeryville. \$10,000/obo. V-8, runs well, radar, chart plotter, and fish finder, walk around pilothouse. (925) 228-7136.



**42-FT CALIFORNIAN, 1979.** Ventura. \$110,000. Best 42-ft Californian on the market. Just surveyed and appraised at \$127,000. 3208 Cat engines. Fully enclosed flybridge. Bimini over center deck. Raymarine electronics, Lofrans Tigres windlass. This boat shows pride of ownership. (805) 320-8765 or email bandphowell@sbcglobal.net.



## 47-FT HARBOR-MASTER HOUSEBOAT.

Oyster Cove Marina, SSF. \$35,000/obo. Liveaboard slip. Fiberglass, twin gas engines. Queen-sized master berth. Double berths in 2nd stateroom. Stereo system, TV, 3 burner range, refrigerator/freezer, AC/heat unit, swim platform, w/s wipers + shore water. Needs new canvas and tune up. OWC loan. Will sacrifice. Need to sell ASAP. Call (415) 459-1461 or email birmint@comcast.net.



**65-FT WOOD CLASSIC, 1939.** Heavy built ex-trawler. GMC 12V-71, 21-kw generator. Full electronics. Lots of equipment. Ready to go. Would make great conversion. Will consider any reasonable offer. More pics/details: (707) 964-5423 or ancona@mcn.org.

**28-FT PROTECTOR, 2001.** Lake Tahoe. Beautiful center console Protector, 99% fresh water use. Two 225-hp Yamahas, under 400 hours. Teak sole. Rear seat, GPS/chart plotter, VHF. Excellent condition and very fast. Call (530) 583-4000 or (530) 518-8500. Or email GD@DorlandProperties.com.

## PARTNERSHIPS

**J/105 SAILBOAT PARTNERSHIP.** San Francisco. Great opportunity to get into a J/105! Current owners looking for a 3rd partner. Boat is in excellent condition for racing and cruising with all the gear to accommodate both. Professionally maintained and is one of the best J/105's on the Bay in terms of condition and gear (too much gear to list). Current partners use the boat for 10 weekends of racing. Interested parties only: Financing also available. Call (415) 297-0794 or email jfwoodley@yahoo.com.



**35-FT J/109, 2004 BELVEDERE, CA.** J/109 sailboat partnership. Mint condition J/109. Active SF racer/cruiser. 1st in SF Bay J/109 Division, 3rd in 2008 PHRF. Also, great family cruiser, sleeps 6+, full kitchen, for Delta, Bay or coast. Interested parties only: call (415) 717-3664 or (415) 819-4589 or ahoy@earthlink.net.

## EXPERIENCED SAILOR FOR 26-FT.

Westerly Centaur. San Carlos, Mexico. \$Negotiable. Share upkeep, berthing fees, and pay small investment fee in exchange for use. Also provide sailing tutoring for relatively inexperienced owner. http://nwbilog.com. (541) 941-2042 or nwbilog@gmail.com.



**OLSON 30 PARTNERSHIP INTEREST.** North Bay or? Trailered, North Bay, maybe San Rafael, Sausalito, SF. \$9,000. Fast fun racer cruiser, needs a slip, sails, handyman, some bottom paint, some minor rigging, mainly sailed in Tahoe. Trade/money. Racer preferred. http://ljoerosa.com. Call (707) 824-6902 or lesstaxes@live.com.

## PARTNERSHIP ON 44-FT BENETEAU.

Looking for 1/3 or 1/2 partnership in a 1995 44-ft Beneteau. Wonderful condition. Sausalito moorage. Leave message. (415) 713-9515 or (415) 492-1634.



**OPERATIONAL PARTNERSHIP.** Vallejo Yacht Club. \$200/mo. Full or operational partnership. Operational partnership = 1/2+ use of boat, and all privileges/responsibilities of ownership, but without principal investment. Champion racer, roomy, comfortable and fast, easy to sail. (925) 376-6723 or (925) 788-7946 or taftster@aol.com.

**34-FT MAINSHIP, 1983.** Established partnership seeks 3rd and perhaps 4th partner. A sailor's power boat. Single 200 hp turbo diesel, semi-displacement hull. Very economical to run. Excellent condition and upkeep. Includes 12-ft RBI with 15 horse outboard. Hydraulic stern thruster, Lectrosan head, Espar heater, genset, all chain and electric windlass anchoring system, fully enclosed flybridge, great music system. Summers in Delta, otherwise at South Beach or Sausalito. 3rd partner buy-in is \$20,000; with 4th, \$15,000. We are very selective about partners! Call (415) 250-8335 or jdietz17@gmail.com.



**superwind.com**



### MULTIHULL YACHT DESIGNER • MARINE SURVEYOR

John R. Marples, CMS • Certified, National Association of Marine Surveyors  
Multihull Design Specialist • Pleasure and Commercial  
Design office for Jim Brown Searunner, Seaclipper & Constant Camber Multihulls  
www.searunner.com • (707) 343-1378 • marplesmarine@comcast.net

### N.E. MARINE TITLE

Coast Guard documentation • Title/lien searches • Transfers • Mortgage filing • Escrow services  
Local closing facility for brokers or private transactions  
30 years experience of doing it right the first time  
1150 Ballena Blvd, Alameda, CA • (510) 521-4925



### MASTERS OF FIBERGLASS & GELCOAT

From Minor Cosmetic to Major Structural  
Custom Fabrication: Hardtops, Swim Decks  
• Marine Services of Marin • 415-686-2214 •

# Mathiesen Marine

For All Of Your Electronics & Electrical Needs

Electrical system troubleshooting & repair to ABYC standards

Visit our new location at  
EmeryCove Yacht Harbor!  
3300 Powell Street, Suite 107, Emeryville

Sales of all major brands of marine electronics  
Professional installation services  
PC & Mac based navigation systems  
Corrosion issues, Inverters, Battery banks  
-Fully Insured-

(510) 350-6622 www.MathiesenMarine.com

**ABYC**  
CERTIFIED  
MASTER  
MARINE TECH

MARINE ELECTRICAL  
MARINE CORROSION  
MARINE SYSTEMS  
ABYC STANDARDS



**HUNTER 36 USE PARTNERSHIP.** San Francisco, South Beach. \$600. 2004 model. Dark blue hull, furling jib and main, dodger, nice interior, well maintained. Qtr usage non-equity for \$600/mo. Typical charter cost is \$470+ per day. South Beach Harbor by ballpark. (408) 375-4120 or snw56x@yahoo.com.

**ESCAPE AND COME SAILING WITH ME.** in La Paz. 6D/7N aboard a beautiful, fully equipped CT 41 with experienced skipper. Trips scheduled for January-June. \$1,200/pp (four max.) Send email for dates and details: charterbaja@yahoo.com.mx.

## TRADE



**AWESOME DONNER LAKE VIEW LOT.** Tahoe. Nothing less than breathtaking. Walk to the lake, minutes to skiing Sugar-bowl. Best lot available, next to million dollar homes. For sale @ \$399,000 with \$300,000 in equity. Trade for world-capable sailing yacht. Love catamarans and classics, houseboat, Marin or Hawaii property or buy outright with very attractive financing. Check out YouTube, key words "Donner Lake Land For Sale": www.youtube.com/watch?v=IFPnqBxCrM0. Contact Ken. Call (530) 412-1068 or kfairchild@jps.net.



## SOUTH OF THE BORDER



**CHARTER DIRECT & SAVE \$\$\$\$.** Owner's time available for discount charter. Beautiful Moorings 4600 cat, Hope, featured in *Latitude 38*. Based in beautiful Belize. Book direct and save big bucks. Email pettyd@comcast.net.



**TIME FOR A CHANGE.** 10 Acres-2 Houses, Fairplay, CA. Think Napa 30 years ago. In the heart of El Dorado County's wine country, 2-1/2 hours from SF. One hour from Tahoe. Check out website. For sale @ \$400,000 with \$150,000 in equity. Also available is an incredible 22-acre parcel that is ideal for a boutique winery with over 1000 feet of frontage on the main wine loop. Spirit Rock Vineyards, home of the Grateful Red, this parcel is dividable into four separated parcels. For sale @ 450,000 with \$350,000 in equity. Trade for world-capable yacht/houseboat, Marin or Hawaii property or sell outright with possible owner finance. See more at www.fairplaywine.com. Contact Ken. Call (530) 412-1068 or kfairchild@jps.net.



**PLAN YOUR MEXICAN GETAWAY NOW.** at the brand-new, gorgeous Cielo Y Mar condos. Located in Punta Mita, 35 minutes from Puerto Vallarta, available to rent from private owner. On the beach, 10 feet from the water, they offer spectacular views of ocean and mountains, the biggest infinity pool in the area, an endless beach, great surf breaks, great fishing, tremendous views of whales, bird life and the islands. While uncrowded and tranquil, just a five-minute walk to several waterfront restaurants. Choose from a spacious, beautifully furnished one or three-bedroom unit, or an amazing two-story penthouse with lovely shade trellis on the top floor. To reserve, call: Dona de Mallorca (415) 599-5012. See more details at: www.puntamitabeachfrontcondos.com.



### OFFSHORE PASSAGEMAKING INSTRUCTION IN THE SOUTH PACIFIC

John & Amanda Neal are dedicated to providing hands-on, documented instruction aboard their Hallberg-Rassy 46 *Mahina Tiare III*, drawing on their combined 502,000 miles and 66 years of experience.

www.mahina.com • (360) 378-6131

Going Somewhere? Mexico • Caribbean • South Pacific

Stop by our office and take a bundle of *Latitude 38* along with you.

We promise you'll be a hero for sharing them with other cruisers!

Latitude 38 • 15 Locust Ave • Mill Valley, CA • (415) 383-8200 • Open M-F 9-5

## "YOUR DESTINATION FOR A FULL SERVICE MARINA"

800 SLIPS 20-60 FT

# Clipper Yacht Harbor

Sausalito, Ca

BRAND  
NEW CONCRETE  
DOCKS!

- Dry Storage Available
- Fuel Dock
- Salty's Bait & Tackle
- Sport Fishing
- Restaurant
- Launch Ramp
- Pump Out
- Laundry Facility
- Private Restrooms and Showers
- West Marine
- KKMI Boat Yard coming soon
- Guest Slips Available

310 Harbor Drive, Sausalito, CA 94965  
(415) 332-3500 • www.clipperyacht.com

# DF DIESEL FUEL FILTERING



## Purify Diesel Fuel & Flush Tanks

Process scrubs, polishes, removes algae, dirt, sludge, rust, water, and foreign particles from diesel fuel. Includes internal tank washdown. Save your injectors, costly engine repair and down time.

Since 1989. Fully insured. Your berth or boat yard.

(510) 521-6797 Fax: (510) 521-3309

www.dieselfuelfilterings.com

# NISSAN MARINE

OUTBOARD SALES, SERVICE, REPAIR, PARTS

(415) 332-8020

Nissan  
Tohatsu  
Johnson  
Evinrude



Honda  
Mariner  
Mercury  
Yamaha

Complete Boat • Trailer • Elec. Repair  
Certified Technicians • Factory Authorized Warranty Facility  
Save 20% on every new engine and install thru 3/15/2010  
35 Libertyship Way • Sausalito, CA 94965

# JUST YOU AND THE SEA...



...and the jacuzzi,  
the 80-ft long pool, the surf,  
the Punta Mita anchorage, and the 4-mile distant  
Tres Marietas Islands

## Punta Mita Beachfront Condos

Call Doña de Mallorca for reservations!

1.415.599.5012

[www.puntamitabeachfrontcondos.com](http://www.puntamitabeachfrontcondos.com)

### Marine Diesel Specialists AT YOUR SLIP!



30 years experience • Universal/Westerbeke dealers  
Repairs/Tune-ups all models • Engine Surveys, Instruction

**BAY MARINE DIESEL**

**510-435-8870**

[baymarinediesel@comcast.net](mailto:baymarinediesel@comcast.net)



See us  
at the  
Seattle  
Boat Show

### Power your stuff!

**10 Amps, 12 Volts @ 15kts**

Kit includes D400,  
regulator, diversion  
load and brake switch.

[www.semarine.com](http://www.semarine.com)

**800 487 0610**

**\$1995**

### Simply Great Sleep



Transform your mattress with our  
box-spring system and enjoy many  
relaxing nights aboard.

**Froli**

phone 888.463.7654  
Nickle Atlantic, LLC

[www.FroliSleepSystems.com](http://www.FroliSleepSystems.com)



**ALPENGLow**  
LIGHTS

**406.889.3586**

### Hand Crafted, High-Efficiency Area Light LED Swivel Reading Light in Chrome or Titanium Finish

Alpenglow Lights use the latest compact fluorescent and LED technology for unmatched efficiency and light quality. The attractive wood fixture is available in different wood choices. Dual power allows choice of bright light or gentle glow, and two levels of red. Prismatic lens designed for wide-angle illumination. Website provides helpful information on selecting cabin lighting.

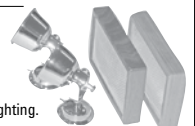

Alpenglow Lights, LLC, P. O. Box 415, Eureka, MT 59917  
[alpenglowlights@gmail.com](mailto:alpenglowlights@gmail.com) • [www.alpenglowlights.com](http://www.alpenglowlights.com)



*A Sailor's  
Consignment  
Chandlery*

**510-769-4858**

Located at Grand Marina

[www.bluepelicanmarine.com](http://www.bluepelicanmarine.com)

## COMPUTER ABOARD?

CAPN & Digital Charts  
AIS • WiFi • Cellular Amps  
SatPhones: Iridium & Globalstar  
HF SSB Radio & Pactor Modems  
*Wireless E-mail*



**SEA TECH SYSTEMS™**

800.444.2581 • 281.334.1174  
info@sea-tech.com • [www.sea-tech.com](http://www.sea-tech.com)

Call for Info on SeaTech Packages and CAPN Demo Disk

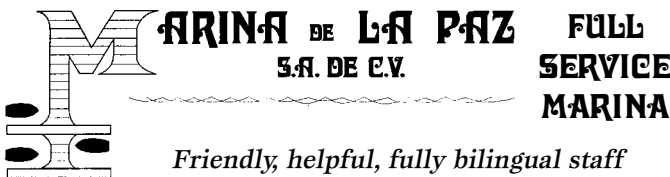

*Friendly, helpful, fully bilingual staff*

All new hardwood docks • Wireless Internet  
Dinghy landing with potable water  
New protective piling & sheetpile breakwaters • And more!

TEL: 01152 612 122 1646  
email: [marinalapaz@prodigy.net.mx](mailto:marinalapaz@prodigy.net.mx)

[www.marinelapaz.com](http://www.marinelapaz.com)

Apdo. Postal 290, La Paz, 23000, Baja California Sur, Mexico

**eMarine Systems**

Solar PV /Wind Generators  
High Output Alternators  
Low Power Refrigeration  
Inverters/Chargers/LED's

Shipping world wide from our Ft. Lauderdale docks  
Authorized Air X/Air Breeze/Whisper repair center

[www.eMarineSystems.com](http://www.eMarineSystems.com)  
salesinfo@eMarineSystems.com  
954-581-2505

## WANTED

**NEED STUFF FOR CRUISING.** Alameda. \$Negotiable. Going cruising... need 8-10hp outboard, Icom SSB with modem, Emergency rudder for Monitor vane (for 39-ft boat). Have 2002 4hp four-stroke Mercury OB for sale. Call (510) 610-1012 or (510) 748-0536 or [casademillard@comcast.net](mailto:casademillard@comcast.net).

**SHIPMATE 214 GALLEY STOVE.** Genuine Shipmate 214 galley stove wanted for a pre-1st World War 53-ft gaff sailing cutter. Preferably with firebricks, suitable for burning coal. (818) 307-0655 or [shipmate214@gmail.com](mailto:shipmate214@gmail.com).

**SWAN OR EXPRESS 37 RACE READY.** Berkeley Marina. No financing needed for the right boat. Must be suitable for single, double handing or convertible to helm and sheet control. Full particulars: boat age, price, sails, gear, location, history photos, specs, etc. Email [ffeied@hotmail.com](mailto:ffeied@hotmail.com).

## GEAR

**WORLD CRUISING ROUTES.** *Ocean Passages of the World*, South Pacific and around-the-world chart kit, Mexico and Caribbean charts and guides. Parachute sea anchors, gale rider, storm chute drogue, offshore medical kit. Satellite phone and email. Call (415) 216-3404 or (619) 277-0593.

**74-FT MAST DESIGNED** for catamaran. Best offer. (415) 269-5165.

**AVON LIFERAFT.** Helena, Montana. \$1,239 plus shipping. Avon 4-person offshore cannister liferaft. Mid-1980s neoprene raft with no deterioration, stored indoors, re-equipped, re-packed, and re-certified in May 2008. (406) 270-0510.

**65' MAST FOR SC 50.** Santa Cruz. \$15,000/obo. Plus lots of other gear, including sails, available. Aluminum Santa Cruz 50 mast, three spreaders, discontinuous rod rigging, measures 65-ft. Also available, lots of sails that fit this mast, plus a bunch of miscellaneous hardware, hydraulics, etc. (831) 818-9696 or [pepeknow@gmail.com](mailto:pepeknow@gmail.com).

## NON-PROFIT

**MARIN POWER & SAIL SQUADRON.** 50 years offering tuition-free safe boating classes, USCG approved. The next America's Boating Classes will be held January 12, 14, 19, 21, 26 and 28, 2010. Final exam is on February 2, 2010. Classes and final exam meet at 7-9 pm, at the same location, the Cal Education Center, 789 North Hamilton Parkway, Novato. Textbook \$40. For registration and information, call (415) 924-2712.

**USCG AUXILIARY SAUSALITO.** Sailing Skills and Seamanship Class. Starts February 9, 2010. Meets Tuesdays, 13 weeks, 7:30pm to 9:30pm at Station Golden Gate. Cost \$75.00 including text book. Contact: Brian Green. (415) 328-6480 or (415) 331-7907 or email [greengibsonsg@yahoo.com](mailto:greengibsonsg@yahoo.com).

**CG AUX BOATING CLASSES.** Santa Cruz Harbor. Boating, Sailing, and Navigation Classes begin January and run 14 weeks. Registration on Wednesday, January 6 from 7:00 to 8:30 PM at the Harbor. Email for information and/or questions. Presented by US Coast Guard Auxiliary. <http://a1130610.uscgaux.info>. Email [wscgaur@gmail.com](mailto:wscgaur@gmail.com).

## PROPERTY SALE/RENT

**5% OWNERSHIP IN SPINNER ISLAND.** Suisun, Ca. \$55,000. Own a 5% share of Spinner Island located just 39 miles from the Golden Gate Bridge or an hour drive from SF or Marin. Deep water channel with 200 feet of docks half way to Tinsley. 4 Bedroom clubhouse on 55 acres. Excellent duck and pheasant hunting. Year round fun. Small private group looking for one or two partners. Park at Pitburg Marina and boat across 5 minutes! [www.spinnerisland.com](http://www.spinnerisland.com) (415) 686-0907 or [john@supercardirect.com](mailto:john@supercardirect.com).

## BERTHS & SLIPS

**50-FT PRIME SLIP PIER 39, SF.** \$46,000. F-Dock, Slip 11, east side. Protected from wind. Close to gangway, showers and marina office. Covered parking across street with special rates for owners. Call (559) 355-6572 or [scorch@tempest-edge.com](mailto:scorch@tempest-edge.com).

**BERTH AVAILABLE SAN FRANCISCO.** 36-ft berth at Pier 39. Very close in. Rental by month or annually. (415) 474-2474.

**40-FT SLIP AVAILABLE FOR RENT.** Pier 39, San Francisco. Middle of D dock with great views of Coit Tower and the Bay! Great marina facilities including laundry, showers, security and friendly staff. Reduced parking rates. \$360/month. (425) 643-0614.

## CREW

**SEEKING EXPERIENCED CREW.** Seeking experienced crew to sail to the Bahamas in the summer of 2010. Well founded 52-ft ketch. Share expenses. Please respond via email: [helekakau@hotmail.com](mailto:helekakau@hotmail.com).



## YOGA FOR SAILORS ON THE SAN RAFAEL WATERFRONT

*Bow Yoga*

Small group classes Wednesday mornings 8:00-8:45 & 9:00-9:45; Wednesday & Thursday evenings 6:30-8:30. First class free when you mention this ad! 143 Third St., San Rafael. [yogaforu2009@gmail.com](mailto:yogaforu2009@gmail.com), (415) 785-4530 or (510) 333-8846

## THIS COULD BE YOU...

Let the Classy Classified business ads work for you.

Submit online at:

[www.latitude38.com](http://www.latitude38.com)

# Latitude 38's 2010 SAILING CALENDAR

AVAILABLE NOW!

AVAILABLE FREE AT  
MOST BAY AREA  
MARINE  
BUSINESSES!

"I love Latitude 38's annual Northern California Sailing Calendar. I keep it on my desk all year long and regularly refer to its comprehensive list of events on Bay Area sailing information. It's a great reference tool."  
- Sheila Maher, Assistant Harbor Master,  
Marina Village



[www.latitude38.com](http://www.latitude38.com)

**FAST SHIPPING!**

## NEW AND USED SAILS!

Specializing in production boats and featuring the largest selection of stock sails available anywhere! Save with warehouse volume discounts on Stock Sails, Custom Sails, Sail Covers, Furlers and Accessories. All top Quality.

**All Fully Guaranteed!**

- Full Batten Mains
- Furling Genoas
- Storm Jibs
- Trysails
- Furling Units
- Custom Canvas
- Used Sails

**THE SAIL WAREHOUSE**

Ph. (831) 646-5346 [www.thesailwarehouse.com](http://www.thesailwarehouse.com)

## MORE ENERGY!

**KEEP BATTERIES CHARGED!**

- KISS wind generators
- Solar panels and MORE

**USE BATTERIES EFFICIENTLY!**

- LED lights
- Engel fridge/freezers
- Wonder Wash and more

**HotWire**

[www.svhotwire.com](http://www.svhotwire.com) 727.943.0424

## WEDLOCK, RAMSAY & WHITING

Marine Surveyors

Vessel surveys, consulting, deliveries.

Serving the Bay Area since 1980

[www.norcalmarinesurveyors.com](http://www.norcalmarinesurveyors.com)  
**(415) 505-3494**

## Ryan's Marine

Specializing in Marine Electrical Services for Your Boat

- Electrical system installations from inverters to electronics packages
- Troubleshooting of existing systems
- Dealer for the complete Balmar product line
- Head and holding tank installations

**(510) 385-3842**

Ryan Schofield  
Owner since 1997

email:  
[rssailor@yahoo.com](mailto:rssailor@yahoo.com)

MEMBER  
**ABYC**  
Setting Standards for Safer Boating

**RODGERS & ASSOCIATES**  
 Certified  
**Marine Surveyors**  
 As appointed by Boat US Insurance Services  
 and Institute of London Underwriters  
 ASA - NAMS - LLOYDS



**Tel: 831-475-4468**  
 jrodgers@rodgersandassociates.com

**www.rodgersandassociates.com**

*Electronic Latitude*

Just like *Latitude 38* magazine but... online, three times a week, and *totally different!*

For a free subscription to *Electronic Latitude*, send an email to: [ElectronicLatitude-on@latitude38.com](mailto:ElectronicLatitude-on@latitude38.com) with 'subscribe' in the subject line. We'll then notify you by email each time *Electronic Latitude* is updated!

**www.latitude38.com**

**RPARTS**  
 REFRIGERATION PARTS SOLUTION  
 WE MAKE YOU THE EXPERT



"Do-It-Yourself" with RParts at unbeatable prices. We can help you fix a system or build it new.

*Assembled Water-Cooled DIY Kit shown*

**www.rparts.com**

**Donate your Boat**  
**Cars, Trucks, RVs, & Real Estate**  
 We handle all DMV & Smog  
 Running or NOT (restrictions apply) **Tax Deduction**

**BLUEWATER NETWORK** | **800-324-7432**

"Proceeds help **Bluewater Network** reduce greenhouse gases, clean up our air and water, and protect marine mammals and wildlife."

**ADVERTISERS' INDEX**

AB Marine..... 50	Brisbane Marina..... 10	Essex Credit Corp..... 59	Hydrovane..... 107	Marina Village..... 51
Albatross Yacht Charters..... 136	BVI Yacht Charters..... 137	Farallone Yacht Sales..... 7	Interlux Yacht Finishes..... 25	Marine Engine Co..... 158
Almar Marinas..... 49	City Yachts..... 11	Flying Cloud Yachts..... 168	Kissinger Canvas..... 73	Marine Outboard Co..... 162
Alpenglow Marine Lights..... 163	Clipper Yacht Harbor..... 162	Footloose Yacht Charters..... 134	KKMI - Brokerage..... 169	Marine Servicenter..... 12
Anacortes Yacht Charters..... 135	Coast Marine..... 107	Forespar..... 34	KKMI - Full Service Boatyard..... 172	Mariner's General Insurance..... 74
Annapolis Performance Sailing..... 65	Conch Charters..... 137	Fortman Marina..... 75	KKMI - Hula Girl..... 167	Maritime Institute..... 155
Aqua Marine..... 136	Corinthian Yacht Club..... 65	Garhauer Marine..... 31	Landfall Navigation..... 110	Marotta Yachts..... 170
Barillas Marina..... 148	Cover Craft..... 61	Gentry's Kona Marina..... 155	Landing School, The..... 155	Martyr Anodes..... 63
Bay Island Yachts..... 6	Coyote Point Marina..... 23	Gianola Canvas Products..... 135	Lee Sails..... 158	Mathiesen Marine..... 162
Bay Marine Boatworks..... 35	Cruising Yachts..... 13	Golden State Diesel Marine..... 155	List Marine Enterprises..... 73	Matt Gardner, Artist..... 61
Bay Marine Diesel..... 163	CYOA Yacht Charters..... 137	Grand Marina..... 2	Loch Lomond Marina..... 73	Mazatlan Marine Center/ La Paz Yachts..... 8
Bellhaven Yacht Sales & Charters..... 135	DeWitt Studio..... 154	Hanse North America/ Moody North America..... 107	Lunasea Lighting..... 67	McDermot Costa Insurance... 95
Berkeley Marina..... 117	Diesel Fuel Filtering..... 162	Hansen Rigging..... 55	Makela Boatworks..... 160	McGinnis Insurance..... 117
Berkeley Marine Center..... 41	Dockwise Yacht Transport..... 90	Harken..... 18	Marina Bay Yacht Harbor..... 37	Milltech Marine Inc..... 68
Beta Marine Engines..... 71	Doyle Sails..... 33	Helms Yacht & Ship Brokers/ West Coast Multihulls..... 168	Marina de la Paz..... 164	Minney's Yacht Surplus..... 155
Blue Pelican..... 164	Dragonfly Sailboats..... 59	Helmut's Marine Service..... 155	Marina El Cid..... 148	Modern Sailing School & Club..... 136
Blue Water Yacht Insurance... 72	e Marine Systems..... 164	Heritage Marine Insurance.. 111	Marina Ixtapa..... 151	Napa Valley Marina..... 64
Bluewater Network..... 166	Easom Rigging..... 94	Hogin Sails..... 52	Marina Nuevo Vallarta..... 111	New Found Metals..... 53
Boat Yard at Grand Marina, The..... 19	El Salvador Rally/Bahia del Sol..... 149	Hood Sails..... 27	Marina Puesta Del Sol..... 150	Nickle Atlantic/ Froli Sleep Systems..... 163
Bottom Siders..... 160	Emery Cove Yacht Harbor..... 55	Hotwire Enterprises..... 165	Marina Real..... 152	Norpac Yachts..... 171
	Emeryville Marina..... 63		Marina Riviera Nayarit..... 43	
	Equipment Parts Sales..... 158		Marina Village..... 21	



**Hula Girl is for Sale!**

This girl is the best of all the Santa Cruz 50s. She's ready to go in the Pacific Cup or to Mexico. With an updated keel and bulb designed by Bruce Nelson, there's no faster or easier girl you could do the hula with. Her carbon fiber mast and boom sets her apart from all the rest as well as a complete and modern wardrobe of sails. Whether you're looking for some fast fun or a great addition to your family, "Hula Girl" is one of a kind.

Please contact Ken Keefe, [ken@kkmi.com](mailto:ken@kkmi.com)  
530 W. Cutting Blvd., Pt. Richmond, CA 94804 (510) 236-6633  
Fax (510) 231-2355 [yachtsales@kkmi.com](mailto:yachtsales@kkmi.com) [www.KKMI.com](http://www.KKMI.com)

**Peter Crane Yacht Sales**

A different kind of yacht brokerage  
(805) 963-8000 [pc@petercraneyachts.com](mailto:pc@petercraneyachts.com)

We can find the right vessel for adventure and lifestyle

Searching for interesting boats interesting people

List with us, ask about commission discounts

**1985 Kelly Peterson 46 cutter**  
rare glass decks, muscular/young 125 hp Yanmar  
excellent gear and condition \$229,000

– cont'd

Norstar Boats/Norstar 40.....57	R-Parts.....166	Seatech.....164	Twin Rivers Marine
North Beach Marine Canvas..47	Raiatea Carenage Services..153	Seaworthy Goods.....69	Insurance.....62
North Direct Sails.....63	Randall Burg Yacht & Ship...168	Smartdodger.....61	U.S. Power Squadron
North Sails.....160	Real World Cruising.....65	Society of Accredited Marine	District 25.....121
North Sails - San Francisco...42	Richardson Bay Marina.....53	Surveyors/SAMS.....121	UK-Halsey Sails.....117
Open Sailing/Open 5.70.....59	Rodgers & Assoc.....166	South Beach Harbor.....46	Ullman Sails.....32
Opequimar Marine Center..150	Rooster Sails.....71	South Beach Riggers.....47	Vallarta Yachts.....58
Orange Coast College.....29	Ryan's Marine.....165	Southeast Marine Services...163	Vallejo Marina.....56
Owl Harbor.....69	Sail California.....14,15,16	Starbuck Canvas.....22	Ventura Harbor Boatyard....152
Oyster Cove Marina.....60	Sail NW / NautiGirl.....135	State Farm Insurance -	Voyager Marine.....22
Oyster Point Marina.....111	Sail Warehouse, The.....165	Jon Jones.....136	Weatherguy.com.....155
Oyster USA.....39	Sailrite Kits.....36	Strictly Sail Pacific.....45	Wedlock, Ramsay & Whiting
Pacific Crest Canvas.....53	Sal's Inflatable Services.....110	Svendsen's Boat Works.....20	Marine Surveyors.....165
Pacific Yacht Imports.....9	San Diego Sunroad Marina	Svendsen's Marine.....44	West Marine.....24,26,28,30
Pantaenius America, Inc. ....158	Boat Show.....66	Svendsen's Marine -	West Marine - Rigging.....67
Paradise Village.....91	San Francisco Boat Works....106	SeaLand.....71	Westwind Precision Details....47
Passage Yachts.....5	San Juan Sailing.....135	Swedish Marine.....57	Whale Point Marine Supply...54
Peter Crane Yacht Sales.....167	Santa Rosa Boat Center.....48	Swiss Tech America.....55	White, Chris Designs.....160
Pineapple Sails.....3	Sausalito Marine Electrical	The Dinghy Doctor.....95	Wright Way Designs.....67
Punta Mita Beachfront	Shop/Artisan Marine.....57	TMM/Tortola Marine	Wyliecat.....75
Condos.....163	Scanmar International.....40	Management.....137	Yacht Racing Association
Quantum Pacific.....17	Schoonmaker Point Marina....95	Tradewinds Sailing.....38,70	.....128,129
Quickline.....75	Seashine.....69	Trident Funding.....4	Yachtfinders/Windseakers.....10



Remember to tell 'em  
**Latitude**  
sent you!



# Flying Cloud Yachts



**Hans Christian**

**GEMINI**

Sail • BROKERS • Power

MEMBER  
**Boat Wizard**  
M.L.S.  
YachtWorld.com

6400 Marina Drive  
Long Beach, CA 90803

www.yachtworld.com/fcyachts  
flyingcloud@verizon.net

Phone (562) 594-9716  
Fax (562) 594-0710



36' MARINER KETCH, 1972 \$49,900



47' GILS CATAMARAN, '02 \$395,000



43' CONESSA SLOOP, 1978 \$134,000



44' HARDIN KETCH, '78 \$119,000



HANS CHRISTIAN 43T ketch \$150,500



43' SPINDRIFT PH CTR, '81 \$79,900



48' MARINER, '81 \$145,000



40' CATALINA 400 MkII, '02 \$179,000



BENETEAU 473, '05 \$275,000



57' BOWMAN, '78 \$199,000



NEW GEMINI 105Mc, '09 \$162,500



42' CATALINAS '89 & '93

APPROX. 100 LISTINGS ON OUR WEB SITE: [www.flyingcloudyachts.com](http://www.flyingcloudyachts.com)

## Randall Burg

YACHT AND SHIP, INC.

info@rbyachts.com

www.rbyachts.com

Richmond (510) 232-1490

Marina del Rey (310) 574-9449

Newport Beach (877) 297-3831

San Diego (858) 208-8888

### ◆ BANG FOR THE BUCK ◆



35' FUJI, 1976. Traditional styling and quality construction. Well equipped and priced to sell. \$44,900!



59' WILLIAM CRUISING KETCH, 1975. Rugged F/G hull built for world cruising. Great liveaboard. Lots of space and strong. Priced to sell. \$145,000.

### YOUR SHOPPING LIST: START HERE

SIZE	TYPE	LOCATION	PRICE
80'	COOPER QUEENSHIP MOTOR YACHT, '91	DELTA	\$695,000
60'	CUSTOM HOUSEBOAT, '78	SAUSALITO	\$295,000
59'	WILLIAM CRUISING KETCH, '75, new electronics	RICHMOND	\$145,000
57'	NORTHERN MARINE TRAWLER, '04	ANACORTES	\$1,650,000
53'	BENETEAU 532, '06	MARINA DEL REY	\$539,000
50'	GULFSTAR CC, '79	SAN RAFAEL	\$124,000
49'	GRAND BANKS ALASKAN	DANA POINT	\$269,000
48'	DEFEVER TRI-CABIN, '80	EMERYVILLE	\$185,000
47'	BENETEAU 473, 3-stateroom, '06	SAN DIEGO	\$299,000
47'	VAGABOND, excellent liveaboard, '81	ALAMEDA	\$145,000
46'	KELLY PETERSON, '86	MARINA DEL REY	\$229,000
46'	HUNTER 460, '00	SAN PEDRO	\$217,500
45'	MORGAN by CATALINA center cockpit, '92	SAN DIEGO	\$159,000
43'	PETERSON SERENDIPITY, '81	SANTA CRUZ	\$76,500
43'	GRAND MARINER, excellent liveaboard, '70	OAKLAND	\$57,000
42'	MARINE TRADER TRAWLER	DELTA	INQUIRE
42'	NOVA SUNDECK TRAWLER, 'Bristol', '87	STOCKTON	\$137,500
41'	HUNTER AC, standard interior, '04	SAN DIEGO	\$165,000
37'	ALBERG, Whidbey-built, '72, upgraded	RICHMOND	\$69,500
36'	HUNTER 386, '04	SAN RAFAEL	\$149,000
33'	TARTAN, '80, Tartan quality. Reduced.	RICHMOND	\$18,500
24'	SKAGIT ORCA COMMERCIAL, new diesel, '00	RICHMOND	\$60,000

**\$50,000,000 IN PRE-OWNED BOATS**

## M U L T I H U L L S

### GEMINI 105M

Loaded with all of the extras.  
Ultra clean.  
Ready to be enjoyed.



### 36' SEAWIND 1000XL, 2001

Only brokerage Seawind on the West Coast! Well rigged, excellent comfort and performance.  
Just \$195,000



**CORSAIR SPRINT 750**  
2 starting at \$54,900.  
Corsair F-27s from \$39,900.



**31' CORSAIR, 2003**  
\$119,000.  
Also new 28R \$69,000.



Dealer for Seawind Catamarans and Corsair Trimarans

314 Tideway Dr., Alameda, CA 94501

www.helmsyacht.com

(510) 865-2511





# Maritime

## Yacht Brokerage

☎(510) 236-6633 • fax: (510) 231-2355

yachtsales@kkmi.com • www.kkmi.com

530 W. Cutting Blvd., Pt. Richmond, CA 94804

### LIST WITH US!

Ask us about our  
Maritime Protection  
Program to find out what  
a warranty can do for  
the sale of your yacht!



**Sydney 36 CR (2006)** w/fractional rig, 4 swept-back spreaders, non-overlapping head sail, high aspect ratio & very long waterline. Competitive IRC racer. Fitted w/all factory options incl. electric winches, ideal for short-handed sailing. Consider trade such as 'picnic' style powerboat. Encore's fast, fun & easy to sail. **\$279,000**



**Nelson Marek Custom**  
A 92-ft aluminum world cruiser. Recently repowered. Immaculate throughout and in perfect condition. **\$2,850,000**



**Little Harbor 51 (1996)**  
A very comfortable Ted Hood designed pilot-house with full stand-up headroom and 360° visibility. Set up for shorthanded sailing and superbly maintained by an experienced owner. Asking **\$669,000**



**DeVries 86' Motor Vessel (1949/1999)**  
'Elegant', 'Exceptional', 'Exquisite' are just a few words that easily characterize this vessel. MV Far Niente clearly defines the term 'Classic Motor Yacht'. Asking **\$1,950,000**



**Sutton Steel Pilothouse LRC 63 (1976)**  
Ready-to-go global cruiser just completed \$100,000 maintenance/upgrade service. Twin 185hp Perkins for economy and dual gensets. Three cabins + crew's quarters. Asking **\$339,000**



**Beneteau First 40.7 (2001)**  
White Dove won the 2008 West Coast IRC Championship and is in top condition. **MAJOR PRICE REDUCTION**



**Swan 43 (1977)**  
Designed by S&S and with the Nautor Swan pedigree for engineering and construction, this one-owner center cockpit yacht is exceptionally maintained, fully outfitted and ready to go offshore cruising. It is a 'Must See'. Asking **\$149,000**



**Swan 45 (2003)**  
Race or cruise. Rancho Deluxe won her class in the TransPac and was second twice in the Big Boat Series. This boat has all the gear to go cruising and is in perfect condition. **\$625,000**



**Jarvis Newman 36 (1978)**  
Classic flybridge "lobster boat" of Maine build quality. Single engine (160 hrs), queen V-berth with enclosed head. Excellent condition, well maintained and lightly used. Asking **\$139,000**.



**Swan 371 (1981)**  
A Ron Holland design which is very well equipped with newer electronics, sails and has been well maintained. Asking **\$95,000**



**Swan 40 (1996)**  
Frers design, exceptionally well maintained, 2-cabin performance cruiser. Awlgrip Flag Blue hull, comprehensive sail inventory, and full in-slip cover. Asking **\$309,000**



**Herreshoff 'Mobjack' Ketch (1989)** This classic wooden ketch took more than 8 years to complete. Exceptionally well maintained w/a very comfortable and appointed interior layout, she has excellent sailing characteristics for cruising in all weather conditions. **\$160,000**



# Marotta Yachts of Sausalito

Brokers of Fine Sail and Motor Yachts

415-331-6200 • info@marottayachts.com • www.marottayachts.com

See at: [www.marottayachts.com](http://www.marottayachts.com)



### 41' SCEPTRE RAISED CABINTOP CUTTER, 1985

Professionally maintained local boat shows VERY nicely inside and out. Leisure Furl in-boom system w/Hood main, Harken roller furler and 105% Hood jib, updated electronics, more. **\$195,000**

See at: [www.marottayachts.com](http://www.marottayachts.com)



### 43' HANS CHRISTIAN, 1978

Classic offered for sale by original owner. New teak decks (this was a \$40,000 job alone!), Awlgrippped hull, updated interior, optional larger diesel and Telstar performance keel. **\$179,000**

See at: [www.marottayachts.com](http://www.marottayachts.com)



**40' BENEteau FIRST 40.7, 2003** The First 40.7 combines the excitement of a sleek racer with all the comforts of a luxurious cruiser. This one is a well-equipped beauty that shows new inside and out. She's the deep version (preferable for the Bay). **\$179,000**

See at: [www.marottayachts.com](http://www.marottayachts.com)



### 38' HANS CHRISTIAN, 1984

Great shape and extensively updated, epoxy barrier coated bottom, stunning professionally maintained brightwork, low time on Yanmar diesel, heavy duty offshore dodger, much more. **\$134,900**

See at: [www.marottayachts.com](http://www.marottayachts.com)



### 48' C&C LANDFALL PILOTHOUSE CUTTER, 1980

Spacious raised salon performance cruiser that's competitively priced and lying in a transferable Sausalito slip. **\$129,500**

See at: [www.marottayachts.com](http://www.marottayachts.com)



### 46' SEA STAR CUTTER, 1981

Vessel refit after circumnavigation and ready to go again! Replaced teak decks and rigging including chainplates, extensively refurbished interior. Sturdy cruiser ready to take you any place you want to go. **\$115,000**

See at: [www.marottayachts.com](http://www.marottayachts.com)



**35' J/BOATS J/105, 2000** Lightly used and very clean, includes the factory Comfort, Systems and Custom Wheel options, plus dodger, roller furler, and 2009 mainsail, 2008 jib, three spinnakers, more. Transferable Sausalito YH slip. **\$109,000**

See at: [www.marottayachts.com](http://www.marottayachts.com)



### 37' HUNTER 376, 1999

Very spacious, light and airy, this vessel shows as new; must see to appreciate. Out-of-country owners motivated; offers encouraged. Sausalito Yacht Harbor slip can be arranged. **\$97,000**

See at: [www.marottayachts.com](http://www.marottayachts.com)



### 38' HANS CHRISTIAN, 1979

Shows well inside and out with the Burmese teak interior in particular showing beautifully. Hull recently buffed and waxed. Teak decks in fine shape as well. **\$94,000**

See at: [www.marottayachts.com](http://www.marottayachts.com)



### 34' JEANNEAU SUN ODYSSEY 34.2, 1999

Professionally maintained, extensively updated. New sails, Harken roller furler, canvas and isinglass, electronics, batteries. Yanmar diesel serviced annually, bottom just painted, much more. **\$77,000**

See at: [www.marottayachts.com](http://www.marottayachts.com)



### 41' MORGAN OUT ISLAND, 1979

Center cockpit ketch. Never cruised and fresh water kept, she shows much newer than actual age. Note all new stainless steel ports. **\$69,000**

See at: [www.marottayachts.com](http://www.marottayachts.com)



### 38' INGRID, 1984

Clean, never cruised one owner example with low time on diesel engine (only 155 hours), custom finished interior, much more. **\$64,500**

See at: [www.marottayachts.com](http://www.marottayachts.com)



### 30' NONSUCH ULTRA, 1987

Professionally maintained, the interior is flawless and the exterior comes close. Transferable Sausalito Yacht Harbor slip that has a great views. A nice, must-see package. **\$59,000**

See at: [www.marottayachts.com](http://www.marottayachts.com)

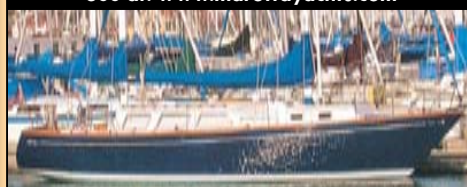

### 40' CHALLENGER KETCH, 1973

Recently Awlgrippped in beautiful Flag Blue, incredibly spacious below with 6'5" headroom. **\$55,900**

See at: [www.marottayachts.com](http://www.marottayachts.com)



**35' BABA, 1979** Traditional double-ender with a recently revarnished interior. She also sails well and will make a perfect cruising yacht for someone who wishes to sail places with grace and style. Transferable Sausalito Yacht Harbor slip. **\$49,500**

at 100 BAY STREET • SAUSALITO • CALIFORNIA 94965 since 1946

# NORPAC YACHTS

1150 Brickyard Cove Rd., B9, Pt. Richmond, CA 94801

(510) 232-7200 • FAX (510) 232-7202

email: info@norpacyachts.com

**WE HAVE BUYERS FOR YOUR BOAT!**

**NOW is the time to list with NORPAC**

**FOR MORE  
SEE OUR**

**norpacyachts.com**

**WEBSITE**



**35' COLUMBIA SLOOP.** Very nice and highly desirable "10.7" design. Dsl, full galley, shower, wheel, dodger, bimini, RADAR, AP, Teak and Holly sole & MORE! Cruise equipped and well maintained and upgraded. **\$30,950/offers**



**62' 1926 CLASSIC MOTOR YACHT.** Well found, elegant, comfortable. A rare offering: Genset, twin 671 dsls, much recent professional upgrading/planking/refastening/+. Copper riveted, full galley, windlass, full teak life rails, more! Must see! **\$124,950/offers**



**32' ARIES.** Ocean cruising sloop. Highly respected double-ender by Tom Gilmer. Glass, beautiful TEAK appointments. Extra nice and loaded for cruising: RADAR, furling, self-tailing winches, vane, dodger, dinghy, diesel. Ready to cruise. Asking **\$36,950/offers**



**58' ALDEN BOOTHBAY MOTORSAILER** center cockpit ketch. Dsl, genset, air/heat, new upholstery, much recent refitting & refinishing. Loaded w/cruise gear, AP, radar ++. Great comfortable bluewater cruising w/excellent layout & more! Ask **\$268,950**



**31' CLASSIC CHINESE JUNK.** Beautifully appointed, comfortable and loads of character. Constructed of rare tropical hardwoods. Monterey, CA mooring possible. Talk about your ideal *Pied-a-Mer!* Moving, must sell. Appears in EXCELLENT CONDITION. This is a great opportunity. Asking **\$21,950**



**49' CUSTOM** Cold-Molded Ketch by Reliant. Beautiful Hankerson design. Powerful and seaworthy blue water cruiser in great shape. Built '91. Yanmar diesel, furling, self-tailors, aux. genset, full galley, full electronics and MORE! MUST BE SEEN. Asking **\$124,750**



**41' CHB** Trawler Long Range Cruiser. Great cruiser for North or South, up the Delta or just live aboard. Bow thruster, diesel, radar, etc. Aft stateroom, 2 heads, 2 staterooms, flybridge, full amenities and the rest...and MORE! Asking **\$49,950**



**40' X-YACHTS X-119 SLOOP.** Famous Danish builder, Racer-Cruiser one design by Neils Jeppesen. Loaded with gear, radar, New Volvo Penta diesel in 2000 and MORE! Proven ocean winner in Melbourne-Osaka Race. Asking **\$109,000**



**39' FREYA, STRONG STEEL DOUBLE-ENDED CRUISER.** Diesel, dink and outboard. New paint, solar, furling, RADAR, AP, cruise equipped, comfortable, well appointed. A world-class cruiser and MORE! Asking **\$44,950**



**24' BENETEAU FIRST 23.5** w/many upgrades: New rig by Easom, new Honda 9.9, new North 100% jib on furler & MORE! (Trailer avail. @ negotiable extra). Super fun weekender/racer. EXCELLENT CONDITION! Asking **\$13,950**



**33' CLASSIC LAKE UNION** Dreamboat by Blanchard. Yanmar 75 hp turbo diesel. Careful and lovely with artistry throughout. Classic yachting and a great deal of pleasure awaits you. Asking **\$24,950**



**37' HUNTER CHERUBINI** with cutter rig. Yanmar diesel, autopilot, cruise equipped, dodger. Mexico veteran and MORE! Very popular and well thought of design. Asking **\$34,900**



**32' WESTSAIL.** Double-ended bluewater cruiser. Cruise/live ready. Diesel, vane, great sail inventory. Mexico veteran. Self-tailing winches, dodger. Exceptional boat. Strong, seaworthy and FUN! BAJA HA-HA anyone? Asking **\$48,500**



**48' DUTCH CANAL BARGE** by DeVries. STEEL. Unique cruising liveboard for Bay and Delta. Comfort and character. Diesel, tub, galley, fireplace, salon, convertible aft enclosure, beautiful decor, plus MORE! Make offers. Asking **\$219,000**

## Visit us at BEAUTIFUL & FRIENDLY Brickyard Cove Marina

### SAIL

100' MEGA SLOOP Custom Offshore Performance Cruiser. Comfort & luxury, spacious, sleeps 17, loaded and near new. GREAT CHARTER POTENTIAL!!!..... Asking 975,000  
40' TRIMARAN by Piver. Ketch, dsl, fast, nice, clean. Insures as F/G..... Asking 33,900  
38' INGRID Ketch by Atkins. Great extra STOUT BLUE WATER CRUISER. Glass double-ender, refit & upgraded, vane, diesel, furling, RADAR & MORE!..... Asking 51,950  
38' CLASSIC English Ketch by Reg Freeman. Breathtaking beauty. **Reduced by 25,000!**..... Asking 99,950  
37' GULFSTAR Center Cockpit Slip. Dsl, dodger, aft S/R & MORE. This VESSEL MUST BE SOLD NOW! REPO!..... Ask: 29,950/Make Offers  
36' COLUMBIA. Clean and nice. Yanmar diesel, shower, wheel, dodger and more! Very reliable and FUN!..... Asking 18,500  
33+1/2' ROYAL HUISMAN ALUMINUM Cutter by Alan Gumey: World class builder and designer. Yanmar diesel, new standing rig, nav station, liferaft & MORE!..... Asking 38,500  
31' CHINESE JUNK. Work of art! Possible Monterey mooring. Exquisitely decorated & loaded with character!..... Reduced! Asking 21,950  
30' STEEL SPRAY Replica by Bruce Roberts. This is a NEW BOAT, never launched. Joshua Slocum's famous *Spray* design w/diesel, mast & more! Exterior looks ready to launch. Interior started, but not finished. AHOY BARGAIN HUNTERS!!! This looks like a good one..... Asking only 14,900  
30' SAGITTA Sloop. F/G, diesel, fine Danish double-ender..... Reduced..... Asking 11,950  
30' CATALINA Slip. Dsl, wheel, nice. 22,000  
29' PEARSON TRITON. Diesel, much refitting recently done, some left to do, very nice pocket cruiser..... 15,950/offers  
28' HERRESHOFF H-28 ketch with brand NEW YANMAR diesel. Some deferred maintenance. A bargain at..... Asking 8,950/offers  
27' CAL 2-27 Sloop. Extra nice. Inboard. Good starter boat..... REDUCED TO 4,750

**POWER**  
130' CAMCRAFT Passenger Ship. Certified for 33 passengers overnight. Booked for the season. Virtual turnkey: Money and opportunity, working PNW..... 2,200,000  
100' Steel HIGH ENDURANCE ADVENTURE/CHARTER SHIP in Panama. Turnkey operation. A great opportunity! MOTIVATED!..... Asking 1,500,000  
62' ELCO 1929 CLASSIC Twin diesel, beautiful yachting in the classic Gatsby style..... Asking 124,950  
62' TRUMPY Classic 1946 Ocean Cruising Yacht. Gorgeous interior and super comfortable layout. Exterior refinish/restore due. Economical twin 4-71s ++. OFFERS ENCOURAGED..... Asking 149,500

56' HOLIDAY MANSION Cruising Catamaran HOUSEBOAT. High-end custom interior, twins & MORE! **Seller Motivated.**..49,950/offers  
50' TRUMPY TRAWLER, Long range, great layout, 671 N-Series diesel. Needs TLC. A great boat!..... 44,950/offers  
49' CLASSIC 1928 STEPHENS Raised Deck Express Cruiser. Twin 671 dsls, much recent prof. upgrading, fire damaged aft cockpit. Great opportunity.....24,950/offers  
47' CRUISING HOUSEBOAT by Suwane. Totally rehab'd and sparkling. Great liveboard..... 29,950/offers  
45' STEPHENS 1929 classic. Beautiful Gatsby-era motor yacht waiting to transport you back to the days of yachting in the grand style..... Try 75,000  
45' CHRIS CRAFT CLASSIC BULL-NOSE "CONNIIE". Twins, outstanding condition. Collector's piece..... 24,950/offers  
43' CLASSIC CALLIS 1923 Custom Express Cruiser. All TEAK, famous and an exquisite head turner. REDUCED \$200K.... Asking 495,000

43' MATTHEWS, '65, diesel. A gem! Loaded and beautiful..... Asking 69,450  
42' GRAND BANKS Twl. Aft cabin, F/B, Onan, twin dsls, radar. Excellent..... 121,000  
41' CHRIS CRAFT Const. Twins, aft S/R, bridge up and more. A good cruiser or liveboard..... Reduced to 10,950/offers  
34' CLASSIC LAKE UNION DREAMBOAT, 1928. Dsl, full aft canopy, enclosure and much more!.....A BARGAIN @ 17,500 Asking  
32' BOWPICKER, aluminum. Commercial (herring) license..... 49,000  
32' GRAND BANKS Trawler. Classic '70. Dsl, dual helms, full electronics, TEAK decks, economical & MORE!.....Try 11,000  
27' FARALLON Pilothouse, '86. F/G, twin 5L V8s, fast and seaworthy. Just detailed and very nice..... Asking 51,950  
26' PACEMAKER, cabin cruise/V8, nice!.....8,500  
25' CLASSIC JENSEN cabin cruiser w/near new Volvo dsl. Very nice boat.....A STEAL @ 4,950  
22' ALUMINUM PLEASURE TUG. Bufflehead live/cruise. Loaded..... Asking 108,250



**GENTLEMEN'S CLUB AFLOAT**  
Established and unique SF Bay charter business featuring exotic dancers (girls and/or guys for ladies and/or gentlemen), liquor service, comfortable and spacious charter yacht w/tasteful traditional styling and decor. COI for 45 passengers. Turnkey operation; owner retiring. Asking **\$295,000**



**39' SANTANA** by Gary Mull & W.D. Schock. Great designer & builder. Exceptional cond. Perfectly set up for cruising. Strong, seaworthy & comfortable. Wheel, dodger, radar, VHF, GPS, AP, depth, spinnaker, etc. VERY NICE! Asking **\$55,500**

**CALL (510) 232-7200 OR FREE (877) 444-5087**

**OR CALL GLENN DIRECT AT (415) 637-1181**

**FOR INFORMATION & INSPECTION APPOINTMENTS**



**KKMI** **KEEFE**  
**APLAN**  
**ARITIME, INC.**

Your Complete Maritime  
Service Center

**FREE HAULOUTS**  
with Bottom Painting Package through January

**ANTIFOULING  
PAINT SALE**

Blue Water Marine Paint  
Copper Pro SCX 67 Hard™

**RIGGING**  
from Clevis Pins to  
Rig Replacement

*I have been bringing my boats to KKMI for years. Everything from a Westsail 32 to a Nordlund 60, and whether I am having new bottom paint rolled on or an interior rebuilt, they have always done great work; fair, fast and friendly, should be their motto.*

Leroy Berges  
Grand Soleil "Tzigane"

PETER LYONS / WWW.LYONSIMAGING.COM

530 West Cutting Blvd., Pt. Richmond, CA 94804 (510) 235-KKMI (5564)  
Spring 2010 500 Harbor Drive, Sausalito, CA 94965 (415) 332-KKMI (5564)  
[www.KKMI.com](http://www.KKMI.com) for info, rates and updates about the Sausalito facility.