

Latitude 38

# Latitude 38

VOLUME 375 September 2008

WE GO WHERE THE WIND BLOWS

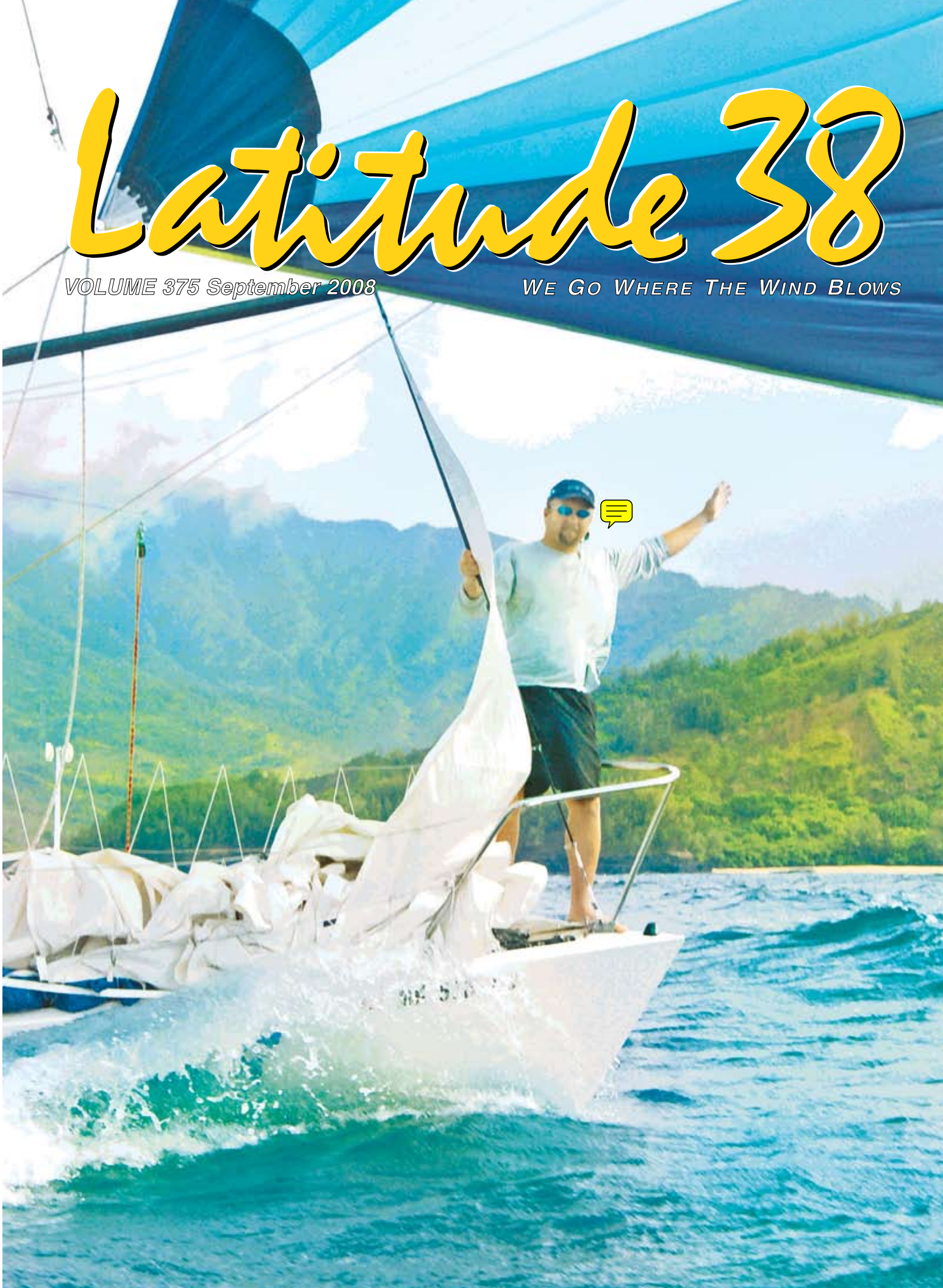

SEPTEMBER 2008

VOLUME 375





***Grand Marina is currently accepting applications for a 100-ft liveaboard berth. This exceptional location affords views of the Estuary, Oakland Hills, and Coast Guard Island.***

- Over 400 concrete berths 30 to 60 feet
- Secured Gatehouses (electronic key system)
- Dockside Electrical (up to 50A - 220V)
- Cable TV & Telephone Service
- Heated & tiled restrooms with individual showers
- Beautifully Landscaped
- Ample Parking available
- Sailboat & Powerboat Brokers on site
- Excellent customer service
- Monthly informative newsletter

**DIRECTORY of  
GRAND MARINA  
TENANTS**

Bay Marine Diesel.....	223
The Boat Yard at Grand Marina..	12
Lee Sails .....	222
New Era Yachts.....	230
Pacific Coast Canvas.....	95
Pacific Yacht Imports .....	11

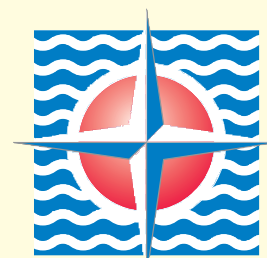

**GRAND MARINA**  
ANDERSON-ENCINAL

**510-865-1200**

Leasing Office Open Daily  
2099 Grand Street, Alameda, CA 94501  
[www.grandmarina.com](http://www.grandmarina.com)

*Our wait list for liveaboard status is now closed.*



# TIZNA

PHOTO: PETER LYONS/WWW.LYONSIMAGING.COM



**Tizna\***

We've all appreciated the classic wood boats, either maintained over decades or beautifully restored. But leave it to Bay View Boat Club of San Francisco to host the "Plastic Classic," and Concours d'Elegance, an annual event that celebrates the advent of fiberglass, both for performance and beauty.

Several years ago, George Luna found an essentially abandoned Morgan 24. He named it "Tizna" (Spanish for serious grime) reflecting the condition the boat was in when he bought her. George now had a restoration project of his own. This year's 24<sup>th</sup> annual Plastic Classic had 56 entrants. In the racing, "Tizna" finished first in class and 4<sup>th</sup> overall, powered by Pineapple Sails, while in the Concours, was awarded the Gold Medal for "Prettiest Boat Overall." Today, the boat wins prizes. For speed and for beauty!

Whether your boat is wood or glass, classic or not, Pineapple Sails will always work to maximize potential, enhance performance, build the best sails you can buy - elegant and fast.

Give us a call today. Or stop by. We are building sails from start to finish right here in Alameda, California. Come by for a tour. We'd love to show you around. We're a classic, afterall. A sailmaker.

YOUR DEALER FOR: Musto foul weather gear, Dubarry footwear and Headfoil 2

Sails in need of repair may be dropped off at:  
West Marine in Oakland, Alameda, or Richmond;  
or Svendsen's in Alameda.

\*Powered by Pineapples



## **PINEAPPLE SAILS**

Phone (510) 522-2200

Fax (510) 522-7700

[www.pineapplesails.com](http://www.pineapplesails.com)

2526 Blanding Ave., Alameda, California 94501



Join us September 6-14 at the  
**NORTHERN CALIFORNIA FALL BOAT SHOW**

New fall models on display from:  
**BENETEAU, ISLAND PACKET, ALERION, WAUQUIEZ**  
Custom Boat Show packages designed for you  
Special Show Events and Seminars



**BENETEAU 49**



**SP CRUISER 41**



**BENETEAU 31**



**ISLAND PACKET 465**



**BENETEAU 37**



**ALERION EXPRESS 28**

*Other Models on Display:*  
**BENETEAU 40, 43, 46, FIRST 10R, WAUQUIEZ 41**

**More September events to mark on your calendar...**

- Sept. 6-14: Northern California Fall Boat Show, Oakland
- Sept. 20-21: Marina Village Used Boat Show, Alameda
- Sept. 21: Passage Yachts VIP Sailing Day (call to RSVP)
- Sept. 20-21: Island Packet Annual Rendezvous



**BENETEAU FIRST 45**

**PASSAGE YACHTS CUSTOMER CARE SERVICES**

We're into long term relationships, and that's why doing business with Passage Yachts means we'll get to know one another. We understand how important it is to have the long term support of boating professionals to make your years of ownership the best they can be, and filled with enjoyment and good memories. This is why we are 'full service' and offer a more comprehensive list of services than any other California dealership. Here's a few:

- International Yacht Brokerage (you don't just get what's at our dock or in our inventory)
- Two Bay Area locations to give you more boats and easy access
- Concierge Services for our owners: regular maintenance, repairs, new installations, outfitting.
- Guaranteed Trade-In/Trade-Up Program: When you buy from us – new or used – we will guarantee a trade-in price, so when you're ready to move up, there's no surprises.
- Financing & Insurance Services: We make sure you get the best market rates with the industry's best. No, "you have to finance with us and take our rates to get your deal" financing here.
- Experienced and Professional Sales and Service Teams: We are sailors as well as consumers and business people. We know what it takes to make your boating and buying experience easy, fun and one of the best.



Klaus Kutz



Don Wilson



Jack Woida



Jim Long



Jim Tull



Chris Corlett



Torben Bentsen



# Passage Yachts Brokerage...



**BENETEAU 393, 2007 ~ \$184,000**

A new boat at a used boat price. Trade-in with transferable warranty. Pristine condition, 2-cabin, 2-head layout. Must see!



**BENETEAU FIRST 45F5, 1991 ~ \$175,000**

Beautiful Farr-designed yacht featuring twin aft cabins. Loaded with electronics and fresh sails. Ready for the race course or extended cruising.



**ISLAND PACKET 320, 1991...\$88,000**



**BENETEAU 473, '04...\$274,900**



**CAPE DORY 36, '89...\$120,000**



**BENETEAU FIRST 47.7, '01...\$247,900**



**BENETEAU 370, '91...\$79,500**



**HUNTER 31, '86...\$22,000**



**PASSPORT 40, 1986...\$134,500**



**SABRE 38, '05...\$321,900**



**BENETEAU 400, '94...\$124,900**



**BENETEAU 423, '03...\$197,000**



**ISLAND PACKET 370, '04...\$299,000**



**BENETEAU 361, 2000...\$118,000**

EXPLORER 45, '79..... \$130,000  
TARTAN 44, '75 ..... 79,000  
BARNETT 42 CUSTOM, '86 .. 135,000  
TAYANA VANCOUVER 42, '79 . 89,000

TARTAN 4100, '01 ..... 275,000  
CASCADE 41, '71 ..... 59,500  
J/41, '85 ..... 66,000  
CARROLL MARINE 1200, 95... 85,000

BENETEAU 390, '90 ..... 94,500  
WAUQUIEZ HOOD 38, '79 ..... 77,500  
BENETEAU 11.5, '85 ..... 63,000  
BALTIC 37, '80 ..... 89,000

CS 36, '84 ..... 64,900  
GIB'SEA 33, '01 ..... 79,900  
TIARA 29, '98 ..... 94,500

## OUR SERVICES:

**FINANCING ~ FULL SERVICE DEPARTMENT ~ CONCIERGE SERVICES**



FOR THE TIME OF YOUR LIFE

**Pt. Richmond  
Office**

1220 Brickyard Cove Rd  
p: 510-236-2633  
f: 510-234-0118

**Two  
Locations!**

www.passageyachts.com ■ sales@passageyachts.com

**Alameda Office  
Marina Village**

1070 Marina Village Pkwy  
Suite 101  
p: 510-864-3000  
f: 510-337-0565



# PUSSER'S®

*"The single malt of rum™  
and the father of grog"*



**Forbes** writes, "Pusser's is still made in the same way it was at the time of Trafalgar - in wooden pot-stills as opposed to modern industrial column-stills. This results in the most full-flavored rum available anywhere".



**The original Navy Rum and the father of grog** as the rum of the Royal Navy and Royal Marines for more than two centuries.



*Gold Medals, London, 2001  
San Francisco, 2003 & 2005*



**P**usser's isn't for everyone. Some people prefer rums that are almost flavorless when compared to the intensely rich flavor of Pusser's. But if you want a rum that you can enjoy sipping, or still taste through the mix of your favorite cocktail, then Pusser's is for you. Try a Pusser's and Cola sometime and taste the difference.

Pusser's is not always easy to find but your local retailer can order it for you. Or take a look at **HOW TO FIND IT** on our web site at

[www.pussers.com](http://www.pussers.com)

*Charles Tobin*

Charles Tobin, Chairman

IMPORTED BY SHAW-ROSS INT'L IMPORTERS, MIRAMAR, FL. PUSSER'S RUM 42% ALC/VOL.

## CONTENTS

subscriptions	10
calendar	26
letters	36
loose lips	96
sightings	100
pacific cup	118
king harbor race	128
singlehanded transpac	134
idiot's guide to marine ssb	144
ha-ha profiles, pt. I	150
max ebb: looking for a fix	164
the racing sheet	170
world of chartering	182
changes in latitudes	190
classy classifieds	210
advertisers' index	223
brokerage	228

Cover: Surfin' Safari - Eric Thomas sails into Hawaii in the Singlehanded TransPac.

Photo: Latitude 38/JR

Copyright 2008 Latitude 38 Publishing Co., Inc.

*Latitude 38* welcomes editorial contributions in the form of stories, anecdotes, photographs - anything but poems, please; we gotta draw the line somewhere. Articles with the best chance at publication must 1) pertain to a West Coast or universal sailing audience, 2) be accompanied by a variety of pertinent, in-focus digital images (preferable) or color or black and white prints with identification of all boats, situations and people therein; and 3) be legible. These days, we prefer to receive both text and photos electronically, but if you send by mail, anything you want back must be accompanied by a self-addressed, stamped envelope. **Submissions not accompanied by an SASE will not be returned.** We also advise that you not send original photographs or negatives unless we specifically request them; copies will work just fine. Notification time varies with our workload, but generally runs four to six weeks. Please don't contact us before then by phone or mail. Send all submissions to [editorial@latitude38.com](mailto:editorial@latitude38.com), or mail to Latitude 38 editorial department, 15 Locust Ave., Mill Valley, CA 94941. For more specific information, request writers' guidelines from the above address or see [www.latitude38.com/writers.html](http://www.latitude38.com/writers.html).





**Catalina**  **Yachts**



*Finalize Your Dream...*

**See these boats at Jack London Square Boat Show! Sept. 6-14th**



**Just Launched!  
The All-New  
Catalina 375**

We're Introducing

*Ranger Tugs*



**Catalina C-400**

**New Catalina's In Stock**



**World's Largest Catalina Yacht Dealer!**



2008 Catalina Hull 42 MK II  
Hull 1000



2008 Catalina 34 In Boom Furling  
Hull 1799



2008 Catalina 350  
Hull 471

**Marina Village Boat Show Sept. 20 & 21**

**Preowned Catalina Yachts**

Catalina 42	2002	\$198,000
Catalina 400	1997	\$139,000
Catalina 380	1998	\$130,000
Catalina 36	1995	\$89,950
Catalina 36	2003	\$139,900
Catalina 36	1996	\$79,900
Catalina 36	1985	\$55,000
Catalina 36	1987	\$63,000
Catalina 36 Tall Rig	1998	\$84,500
Catalina 36	1990	\$83,500
Catalina 350	2004	\$149,900
Catalina 350	2004	\$158,500

Catalina 350	2004	\$149,000
Catalina 350	2003	\$139,900
Catalina 34	2007	\$126,000
Catalina 34	1989	\$57,500
Catalina 34	2005	\$113,000
Catalina 320	2005	\$119,900
Catalina 270	1995	\$36,900

**Preowned Sailing Yachts**

Mikelson Cutter 50	1988	275,000
Cavalier 45	1985	255,000
Lancer 45	1986	120,000
Franz Maas 42 PK	1972	135,000
Valiant 40	1977	95,000
Morgan 38	1979	57,500
Hunter 35	1993	
Hunter 34	1999	84,990
CS 34	1990	61,000
Ericson 28	1987	28,000
<b>Catamaran</b>		
Fountaine Pajot	1995	\$325,000

1070 Marina Village Pkwy.  
Alameda CA 94501  
510 • 523 • 6730



2302 Shelter Island Drive  
San Diego CA 92106  
619 • 523 • 6730

**ALAMEDA • NEWPORT BEACH • SAN DIEGO**  
[www.faralloneyachts.com](http://www.faralloneyachts.com)

# Jeanneau



JEANNEAU

America's Most Popular Imported Sailboats



2008 Jeanneau 39i



2008 Jeanneau 42 Deck Salon



2008 Jeanneau 49i



2008 Jeanneau 45 Deck Salon

## PRE-CRUISED SPECIALS

2005 Tartan 4400 .....	\$525,000
2001 Hunter's Child 50 (53').....	\$449,000
2006 Hunter 45 Center Cockpit.....	\$329,000
2007 Hunter 44DS (Three Cabin).....	\$269,950
1998 Beneteau 42.7 .....	\$179,999
2005 Hunter 38.....	\$179,999
2004 Hunter 36.....	\$119,995
2003 36' Hunter 356.....	\$114,999
1983 43' C&C Landfall .....	\$109,995
1999 Hunter 310 .....	\$55,000
1975 Westsail 32, .....	\$44,900
1996 Hunter 280 .....	\$34,900
1976 Pearson 26.....	\$7,900

Visit [www.cruisingyachts.net](http://www.cruisingyachts.net) for details.

## Charter Ownership

Under the 2008 Economic Stimulus Act, you can **deduct \$250,000 or more on your personal income taxes** for boats purchased and placed in charter in 2008. See our website and contact us for details.

**Call: 888-78-YACHT**



# Hunter



**We'll make your payments until April 2009 on all NEW boats in stock!**

## America's Best Selling Sailboats



**Hunter Mid-Range Cruisers 31 – 38 Feet**



**Hunter Full –Size Cruisers 41-50 Feet**



**Mike Harker**  
Cruises the World  
in a Hunter 49



**Hunter Center Cockpit 45 Feet**



**Hunter Deck Salons 41 – 45 Feet**

### We Need Used Boats!

- We sell more boats 30' to 60' than anyone in the Bay area
- We'll buy your boat, take it in trade, or sell it for you
- All makes and models
- Your boat will appear in the leading boat publications and websites
- Your boat will be displayed at our show dock

**We'll make your payments until April 2009 on all new boats in stock!**

- Boats Open 7 Days a Week
- Top 5 Hunter Dealers 2007
- Top 10 Service Department
- Inhouse Financing Available
- We take trade-ins!



**Cruising Yachts, Inc.**

Alameda  
**888-78-YACHT**  
[www.cruisingyachts.net](http://www.cruisingyachts.net)

# ❖ 60' SLIPS ❖

## NOW AVAILABLE



**PEACEFUL, PROTECTED  
FIRST-CLASS YACHT HARBOR**

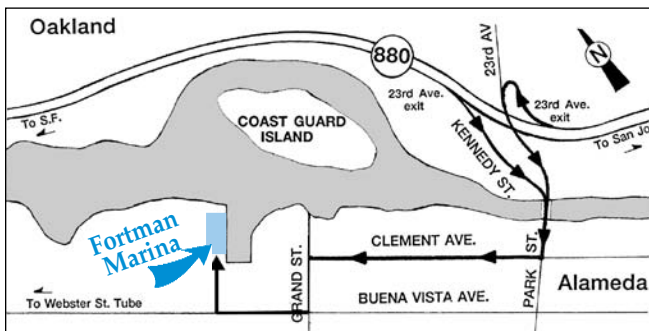

- Sheltered Alameda Location
- Competitive Rates
- Home of the Alameda Yacht Club

1535 Buena Vista Ave., Alameda, California  
**(510) 522-9080**

For directions and rates go to:  
**www.fortman.com**

## SUBSCRIPTIONS

Please read form carefully before submitting.

We regret that we cannot accept foreign subscriptions. Check, money order, or credit card information must accompany request. Please allow 4-6 wks to process changes/additions, plus delivery time.

Enclosed is \$18 for one year on eBook



Check out [www.latitude38.com](http://www.latitude38.com) and click on eBooks to see what we're talking about. Our eBooks are now in PDF format, easy to use with Adobe Reader

Enclosed is \$36 for one year Third Class Postage

(Delivery time 2-3 weeks; Postal Service will not forward third class, so you must make address change with us in writing.)

Enclosed is \$55 for one year First Class Postage (Delivery time 2-3 days; FPO/APO (military), Canada & Mexico subscriptions are first class only)

Third Class Renewal  First Class Renewal *(current subs. only!)*

Gift Subscription – Card to read from: \_\_\_\_\_

Name \_\_\_\_\_

Address \_\_\_\_\_

City \_\_\_\_\_

State \_\_\_\_\_

Zip \_\_\_\_\_

Phone: ( ) \_\_\_\_\_ Email: \_\_\_\_\_

**CREDIT CARD INFORMATION**  
Min. Charge \$20

MASTERCARD

VISA

AMERICAN EXPRESS

Number: \_\_\_\_\_

Exp. Date: \_\_\_\_\_

### INDIVIDUAL ISSUE ORDERS

Current issue = \$6.00 • With classy ad placed = \$5.00

Back Issues = \$7.00 (must indicate exact issue by month or vol. #)

### DISTRIBUTION

We have a marine-oriented business/yacht club in California which will distribute copies of *Latitude 38*. (Please fill out your name and address and mail it to the address below. Distribution will be supplied upon approval.)

Please send me further information for distribution outside California

Business Name \_\_\_\_\_

Type of Business \_\_\_\_\_

Address \_\_\_\_\_

City \_\_\_\_\_

State \_\_\_\_\_

Zip \_\_\_\_\_

County \_\_\_\_\_

Phone Number \_\_\_\_\_

# Latitude 38

"we go where the wind blows"

Publisher/Exec. Editor.....	Richard Spindler.....	<a href="mailto:richard@latitude38.com">richard@latitude38.com</a> .....	ext. 111
Associate Publisher.....	John Arndt.....	<a href="mailto:john@latitude38.com">john@latitude38.com</a> .....	ext. 108
Managing Editor.....	John Riise.....	<a href="mailto:johnr@latitude38.com">johnr@latitude38.com</a> .....	ext. 110
Senior Editor.....	Andy Turpin.....	<a href="mailto:andy@latitude38.com">andy@latitude38.com</a> .....	ext. 112
Associate Editor.....	LaDonna Bubak.....	<a href="mailto:ladonna@latitude38.com">ladonna@latitude38.com</a> .....	ext. 109
Associate Editor.....	Rob Grant.....	<a href="mailto:rob@latitude38.com">rob@latitude38.com</a> .....	ext. 105
Advertising Sales.....	John Arndt.....	<a href="mailto:john@latitude38.com">john@latitude38.com</a> .....	ext. 108
Advertising Sales.....	Shawn Grassman.....	<a href="mailto:shawn@latitude38.com">shawn@latitude38.com</a> .....	ext. 107
Classified Sales.....	Mary Briggs.....	<a href="mailto:class@latitude38.com">class@latitude38.com</a> .....	ext. 104
General Manager.....	Colleen Levine.....	<a href="mailto:colleen@latitude38.com">colleen@latitude38.com</a> .....	ext. 102
Production/Web.....	Christine Weaver.....	<a href="mailto:chris@latitude38.com">chris@latitude38.com</a> .....	ext. 103
Production/Photos.....	Annie Bates-Winship.....	<a href="mailto:annie@latitude38.com">annie@latitude38.com</a> .....	ext. 106
Bookkeeping.....	Helen Nichols.....	<a href="mailto:helen@latitude38.com">helen@latitude38.com</a> .....	ext. 101

Directions to our office.....	press 4
Subscriptions.....	press 1,4
Classified.....	press 1,1
Distribution.....	press 1,5
Editorial.....	press 1,6
Calendar.....	
Other email.....	

Please address all correspondence by person or department name

15 Locust Avenue, Mill Valley, CA 94941 • (415) 383-8200 Fax: (415) 383-5816



# Pacific Yacht Imports is Proud to Announce They Have Been Named Exclusive West Coast Dealers for Tayana Yachts



**TAYANA 54 DS WORLD PREMIER AT OUR DOCKS**



**2005 TAYANA 48 DECK SALON**

Like new with only 71 hrs on Yanmar. Raymarine electronics, air/heat, genset, Corian, LeisureFurl main, electric winches.

**\$489,900**

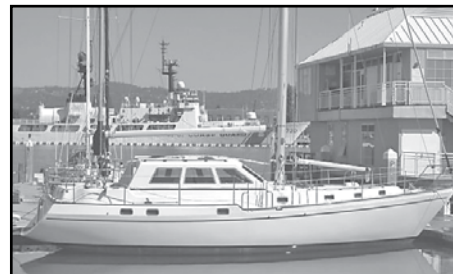

**2007 TAYANA 46 PILOTHOUSE**

Cruise in comfort in any climate with inside steering. With only 12 hours on her Yanmar 100 hp dsl, she is virtually new. Over 1,000-mile range under power.

**\$399,000**



**1977 VALIANT 32 CUTTER**

Classic Robert Perry design. Solid, basic platform to build your cruising boat and priced accordingly. **\$34,500**



**1984 TAYANA V-42** aft cockpit cutter. Mast has new LPU paint, rigging & wiring. Raymarine pkg. incl. AP, radar, GPS plotter AGM batteries. Full cockpit enclosure, 3 genoas, spinn w/sock, extensive equip. list **\$149,500**



**SISTERSHIP**

**2000 BENETEAU FIRST 40.7.** Race ready with many upgrades like larger motor, oversize primary winches, carbon spin pole, professionally faired. **\$189,000**



**1982 SWIFT 40 KETCH.** Sparkman & Stephens-designed center cockpit. Recently back from the South Pacific and in excellent condition with everything you need to go again.. **\$120,000**

*Pacific Yacht Imports*

2051 Grand Street, Alameda, CA 94501

[www.pacificyachtimports.net](http://www.pacificyachtimports.net)

*We're at Grand Marina*

Dave Wolfe, Neil Weinberg, Keith Rarick

Tel (510) 865-2541 Fax (510) 865-2369

[tayana@mindspring.com](mailto:tayana@mindspring.com)

# THE BOAT YARD AT GRAND MARINA

Formerly Mariner Boat Yard

"Where Service Has Meaning"

**Interlux**  
yachtpaint.com

**AWLGRIP**  
AWLGRIP

**60-TON  
TRAVELIFT**



FEATURING  
TRINIDAD  
ANTI-FOULING PAINT BY  
**PETTIT**  
marine paint  
RATED "SUPERIOR" by  
Practical Sailor

*The only yard to brush on your bottom paint!*

Dealers for:

**MAX-PROP**  
AUTOMATIC FEATHERING PROPELLERS

**GORI**  
marine

**Webasto**

PACKLESS SEALING SYSTEM  
**SHAFT SEAL**

**Lectra/san**

**SIDE-POWER**  
Thruster systems

**facnor**  
FURLING SYSTEMS INC.

**AQUAMARINE**  
FINE REVERSE OSMOSIS EQUIPMENT

## IT'S SIMPLE!

Call The Boat Yard at Grand Marina for the Lowest Bottom Prices!

~ COMPARE US WITH THE COMPETITION ~

- Prop and Shaft Work
- Mast & Rigging Repair
- Fiberglass & Blister Repair
- Gelcoat Repair
- Gas & Diesel Engine Service
- LPU Hull & Topside
- Electrical Repair & Installation

**CALL FOR A RESERVATION**

(510) 521-6100 • Fax (510) 521-3684

Located at Grand Marina • 2021 Alaska Packer Place, Alameda

[www.boatyardgm.com](http://www.boatyardgm.com)





**5 Convenient California Locations**  
**Open 7 Days/Week • We take TRADE-INS**  
**#1 DEALER FOR JEANNEAU & HUNTER IN '07**

**888.325.4353**  
**www.HSyacht.com**



**LARGEST INVENTORY OF SAILBOATS ON THE WEST COAST**



'09 HUNTER 49 - BOAT OF THE YEAR AWARD!



'08 HUNTER 45 DS - NEW MODEL! IN-STOCK!



NEW '06 HUNTER 27X - REDUCED TO COST \$47K



'08 JEANNEAU 39i PERFORMANCE VERSION



'09 JEANNEAU 45 DS NEW MODEL! CALL!

**Visit HSyacht.com for daily updates to our brokerage listings!**

1991 Hunter 28	\$29,000	2006 Hunter 36	\$145,000	1991 Hunter 42	\$124,000	1997 Hunter 450	\$179,000
1982 Newport 30	\$12,000	2002 Catalina 36	\$118,000	1989 Catalina 42	\$115,000	2000 Jeanneau 45.2	\$269,500
2005 Catalina 320	\$119,000	2007 Jeanneau 36i	\$172,000	2005 Bavaria 42	\$174,900	2000 Jeanneau 45.2	\$259,000
2002 Hunter 326	\$79,000	2006 Catalina 36	\$160,000	2004 Hunter 420	\$219,500	2005 Hunter 46 LE	\$279,900
2003 Hunter 326	\$77,900	1993 Hunter 37.5	\$83,500	2005 Beneteau 423	\$199,000	2004 Hunter 466	\$249,000
1998 Catalina 320	\$84,900	2006 Jeanneau SO 37	\$190,000	1995 Catalina 42	\$168,500	2002 Hunter 466	\$249,900
2005 Hunter 33	\$99,000	1999 Hunter 380	\$89,000	2000 Hunter 42	\$180,000	1980 Island Trader 46	\$210,000
1996 Hunter 336	\$73,000	1999 Island Packet 38	\$235,000	2003 Jeanneau 43DS	\$259,000	2007 Beneteau 49	\$432,900
2001 Hunter 340	\$87,000	1994 Catalina 38CC	\$119,000	1998 Hunter 430	\$157,000	2007 Jeanneau 49 DS	\$449,000
1981 Sabre Classic 34	\$55,000	2004 Sabre 386	\$305,000	2002 Jeanneau 43 DS	\$249,500	2000 Jeanneau 52.2	\$429,900
1987 Catalina 34	\$49,900	1994 Beneteau 40	\$124,500	2006 Hunter 44 DS	\$268,000	1981 Pearson 530	\$249,000
1999 Hunter 340	two avail.	2004 Hunter 41 AC	\$229,900	2004 Hunter 44 DS	\$249,000	2005 Jeanneau 54DS	\$675,000
1972 Coronado 34	\$29,000	1999 Hunter 410	\$159,000	1996 Beneteau 44	\$149,900	2001 Moody 54CC	\$665,000
2004 Hunter 36	\$148,000	2000 Hunter 410	\$165,000	1999 Hunter 45	\$179,000	2005 Jeanneau 54DS	\$675,000
2002 Catalina 36	\$119,900	1998 Hunter 410	\$132,500	2000 Hunter CC	\$209,000	2006 Jeanneau 54 DS	\$740,000
1999 C&C 110	\$139,995	2003 Beneteau 411	\$189,900	2000 Hunter 450	\$210,000	2004 Jeanneau 54 DS	\$660,000
2005 Hunter 36	\$139,900	2006 Hunter 41DS	\$229,900	1998 Hunter 456CC	\$169,000	1997 Jomar Roberts	\$299,000



'05 Bavaria 42 - \$174,900



'06 Jeanneau SO 37 - \$190K



'99 Hunter 45 - \$179,000



'91 Hunter 28 - \$29,000



'07 Beneteau 343 - \$145K



'06 Catalina 36 - \$118,000



'04 Beneteau 393 - \$162K



'04 Jeanneau 54DS - \$660K



'06 Hunter 41 DS - \$229,000



'06 Hunter 36 - \$149,900

**SAN DIEGO | NEWPORT BEACH | MARINA DEL REY | CHANNEL ISLANDS**



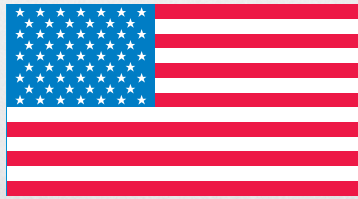

**Along with a great place to berth  
your boat, San Leandro Marina  
offers you a wealth of  
recreational opportunities...**

- **27 holes of championship golf**
- **A waterfront hotel**
- **Fine dining at 2 restaurants  
overlooking the water**
- **40 acres of shoreline park and  
picnic sites**
- **300 acres of tidal wetlands on the  
Bay Trail**
- **2 active yacht clubs**



**(510) 577-3488**

[www.ci.san-leandro.ca.us/slmarina.html](http://www.ci.san-leandro.ca.us/slmarina.html)





**Hans Christian**



# Flying Cloud Yachts

Sail • BROKERS • Power



6400 Marina Dr., Long Beach, CA 90803

Phone (562) 594-9716 Fax (562) 594-0710



**NEW 105Mc - GEMINI, 2009**  
Best selling cruising catamaran in the U.S.!  
\$162,500



**REDUCED 47' GIL'S CHOY CATAMARAN, 2002**  
Ready to cruise the South Pacific today!  
Everything as new, fully equipped. \$395,000



**REDUCED \$30K 49' HANS CHRISTIAN CHRISTINA, 1986** Center cockpit, three cabin Peterson design. Exceptional condition. Only 49' on the market. \$268,000



**NEW LISTING 54' HUNTER SLOOP, 1981** New Yanmar diesel. Upgraded & equipped for cruising. Redesigned transom, keel. \$125,000. Also a 45' Hunter, '99.



**SUBMIT OFFERS 57' BOWMAN KETCH, 1978**  
Five hours on rebuilt 110hp Perkins. New electronics. Top-quality bluewater cruiser. \$219,000



**3 CABINS 50' CELESTIAL PILOTHOUSE SLOOP** Equipped for LRC, sonar depthsounder, air/heat, 8kw genset, wind gen, watermaker. \$250,000/offers



**REDUCED 41' NAUTOR SWAN, 1973**  
Clean and ready to sail. New LP and new bottom paint in 5/07. \$85,000



**40' NORTH AMERICAN SLOOP, 1979**  
Perkins diesel, almost everything is new, tons of upgrades! Call for details. \$55,000



**REDUCED 42' WESTSAIL CUTTER, 1974** Only 400 original hours on 85hp Perkins. Great liveaboard with beautiful interior. A must see! \$99,500

Web site: [www.yachtworld.com/fcyachts](http://www.yachtworld.com/fcyachts) • email: [flyingcloud@verizon.net](mailto:flyingcloud@verizon.net)



**40' CHOATE, 1979** New Yanmar diesel in 1997, low hours, new fuel tank, sleeps 9. Great racer or fast cruiser. \$47,500



**38' HANS CHRISTIANS 1980 & 1986**  
From \$99,000



**36' PEARSON SLOOP, 1986**  
Excellent racer/cruiser.  
Priced to sell immediately! \$48,500



**34' CATALINA SLOOP, '87**  
Original owner, low hours, roller furling and autopilot. Catalina ready! \$42,000



**REDUCED 34' TUNG HWA DIANA CUTTER, 1983**  
Strong, traditional cruiser, new bottom paint, Perkins diesel. \$55,000



**32' ERICSON, '90.** Very clean/well kept; nicest brokerage sailboat on market in this size/price range. New main, jib & cruising spinnaker. \$59,000



**30' CATALINA(s), '79 & '82**  
From \$16,500



**28' CAL SLOOP, '86** Westerbeke dsl, AP, radar, refrigeration. Gennaker & tabernacle mast. Near new condition; priced for quick sale. \$29,500



**REDUCED 27' NOR'SEA SLOOP, 1978**  
Center cockpit, new galvanized trailer, new Yanmar diesel, Aries windvane. \$45,000

Some boats shown may be sisterships.



# BALLENABAY YACHT BROKERS



**BALLENABAY  
YACHTS...  
THE PROVEN CRUISING  
SPECIALISTS**

1150 Ballena Blvd. #121, Alameda, CA 94501 ♦ (510) 865-8600 ♦ Fax (510) 865-5560  
2736 Shelter Island Drive, San Diego, CA 92106 ♦ (619) 523-1151  
♦ [www.ballenabayyachts.com](http://www.ballenabayyachts.com) ♦ [www.trawlers.com](http://www.trawlers.com) ♦ [www.yachtworld.com/ballenabay](http://www.yachtworld.com/ballenabay) ♦



California dealer for

**Valiant Yachts**

Made in the USA



42' VALIANT YACHT, 2008. Where do you want to go? Serious cruisers who sail the oceans choose Valiant. Call for appointment.

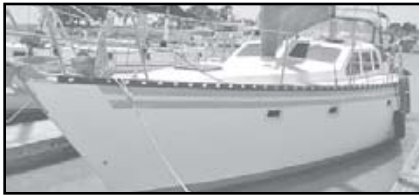

41' COOPER PILOTHOUSE, 1981  
Comfortable, bluewater-capable boat.  
\$89,900



34' PACIFIC SEACRAFT  
\$95,000



39' FAIRWEATHER, 1989  
Proven ocean cruiser and great liveboard.  
\$129,000

Check our Web sites for other fine listings!



**ESSEX  
CREDIT**

NEW - USED - REFINANCE

## Boat Loans Made Easy®



Let our 27 years of experience go to work for you!

**Linda Carroll**

866-377-3948 ext. 7215

[www.essexcredit.com](http://www.essexcredit.com)

Loan Amounts from \$15,000  
Zero Down Program\*

Instant Loan Approvals\*  
90 Days to First Payment\*

\*(Subject to Loan Program Guidelines and Credit Approval)

Reference Code =MAR931

**EQUAL CREDIT OPPORTUNITY LENDER**



# Cityyachts

San Francisco's yacht broker  
since 1969

## YACHTS AND THE CITY



Hunter 45, 2006  
\$299,000



42' Fountaine Pajot Venezia,  
1995, \$234,500



39' Sea Ray 390, 1988  
\$59,500



Sabre 34, 1983  
\$54,900



Passport 40, 1985  
\$114,800



Bayliner 3218, 1987  
\$39,500



32' Grand Banks Sedan,  
1980, \$119,000



37' Sea Ray Sundancer 370,  
1990, \$59,900



30' Hess Bristol Channel,  
1997, \$99,800



37' Beneteau Oceanis 370,  
1991, \$74,900



28' Bayliner 2855, 2000  
\$44,500



27' Farallon Enclosed Helm,  
1982, \$89,000

10 MARINA BL. • SAN FRANCISCO, CA 94123 • Toll Free: 877-444-5091 • 415-567-8880  
FAX (415) 567-6725 • email [sales@citysf.com](mailto:sales@citysf.com) • website <http://yachtworld.com/cityyachts>



PLEASE VISIT OUR FUEL DOCK AT GASHOUSE COVE MARINA • OPEN 7 DAYS A WEEK • 9AM TO 5PM

# YACHTFINDERS

# WINDSEAKERS

(619) 224-2349 • Toll Free (866) 341-6189

2330 Shelter Island Dr. # 207

San Diego, CA 92106

info@yachtfinders.biz

www.yachtfinders.biz



**46' BENETEAU M463, '99** \$159,900  
A great family boat, perfect for entertaining, with a spacious layout and three separate sleeping areas. The boat is ready for Mexico and beyond.

**55' JOMAR CC, '87**  
\$159,900

Few other custom builds match this yacht's extraordinary range of refinement and quality. Hardware is the finest. Mechanical installations are equally outstanding. She was designed, engineered, and built without compromise to ensure the highest degree of structural integrity.



**44' LAVRONOS CC, '89** \$99,000  
A reasonably-priced, hard-to-find steel cutter. The owner is completing the finishing touches and then she'll be ready to take you anywhere.



**36' CATALINA, '86** \$56,900  
This unusual tall rig has a large cockpit and open deck, and performs well on the water. Come see why this is among the most popular designs ever.



**34' CATALINA, '86** \$39,900  
This Catalina 34 is rigged to sail fast and look good. She has a great sail inventory and absolutely beautiful interior. Come view her soon.



**32' SEAWARD EAGLE, '03** \$99,900  
An offshore capable trailer-sailer! Sail to your favorite destination and pull up to the beach. Full of amenities and kept in Bristol condition.



**32' ISLANDER Mk II, '78** \$27,900  
If you're looking for performance, easy handling and comfort, here's a terrific opportunity to own a classic that is very affordably priced.



**30' TARTAN, '74** \$12,000  
Tartans have an excellent reputation and represent quality. *Aerie* is a good performer in local races, ready to share the joy of sailing with you.



**44' MASON, '93**  
\$265,000

Immaculate, stunning and desirable: all of these attributes describe this beautiful yacht, maintained under pridelof ownership from bow to stern by knowledgeable owners. Her beautifully finished interior and amenities offer unmatched comfort. We invite you for a close look.



**27' C&C Mk V, '85** \$18,500  
*Binky* has been lovingly cared for and is a rare opportunity to get you sailing in the style and safety C&Cs are known for. Trailer is included.

## 10% OFF TOTAL INVOICE\*

Summer Savings

# Haulouts for Bottom Painting AND ALL YARD SERVICES

**Interlux**  
yachtpaint.com

\*Must present this coupon for work scheduled by 9/30/08.



**NEW MARINE DIESELS**

**Perkins DIESELS 10% OFF**

SALES SERVICE PARTS

**GENUINE PERKINS PARTS**

Mention this ad ~ Good until 9/30/08

Perkins Authorized Master Service Dealer

We ship worldwide!

**BRITISH MARINE**



**& INDUSTRIAL**

#11 Embarcadero Cove  
Oakland, CA 94606

(800) 400-2757  
(510) 534-2757

Two blocks from West Marine

www.britishmarine-usa.com



Catalina 320, *Four Winds*

# STARBUCK



# CANVAS WORKS

...Unless You Just Don't Care.

67 Liberty Ship Way  
Sausalito, CA 94965

415-332-2509





Successfully Selling Boats in Mexico since 1998

Looking to buy a boat to cruise south to Mexico or beyond? The boat you are looking for is right here!

Over 70 proven, cruise-ready listings await you in Mexico at:

[www.mazmarine.com](http://www.mazmarine.com)

**Fuel Prices Are Much Lower in Mexico!**

MEXICO, possibly the only place you can afford to go cruising AND buy a boat.

**Average fuel prices – Dsl: \$2.80/gal • Gas: \$2.65/gal**

**IT IS TIME TO GO CRUISING!**

**MAZATLAN**

Ray Watson & Jeannette Sarrasin  
Toll free US/CAN: 1 (888) 716-7430  
Phone & FAX: 011 52-(669)-913-3165  
E-mail: Mazmarine@aol.com

**LA PAZ**

Mike Rickman & Shelly Rothery Ward  
Toll free US/CAN: 1 (877) 245-9689  
Phone: 011 52-(612)-123-1948  
E-mail: LaPazYachts@aol.com



**Got Shade?**

- Ingenious, self-supporting awning system, attaches to lifelines
- Tall enough to walk under at cabin, no limbo
- Bombproof construction, easily sustains 25 knots
- Sets up in 10 minutes, stows complete in its own 10" x 36" bag
- 10 standard sizes fit any boat, catamarans too
- Prices from \$300.00 to \$700.00

Visit: [www.intheshd.com](http://www.intheshd.com)

**ShadeTree**

**888-684-3743**

[shadetre@gulftel.com](mailto:shadetre@gulftel.com)



# Cleaner and Greener



**NEW!**  
**Pure Oceans Boat Care Products**

West Marine is proud to introduce our new Pure Oceans line, a new selection of boat care products that have been specifically formulated to be kinder to the environment while delivering performance that equals less environmentally-friendly formulas. The Pure Oceans line includes soaps, cleaners and surface care products that are inherently less toxic, less environmentally persistent, less bio-accumulative and that degrade to substances with similar desirable characteristics when compared to ingredients in conventional formulations. Be good to your boat, and be good to the environment with West Marine's new Pure Oceans Boat Care Products.

**West Marine**  
*We make boating more fun!*

Visit our **Alameda Sailing Superstore!**  
730 Buena Vista Ave. • 510-521-4865

We have 22 stores in Northern California.  
Log onto [westmarine.com](http://westmarine.com) or call **1-800-BOATING** to find the store nearest you.

# SPECIALIZING IN BLUEWATER CRUISING YACHTS

Visit our website at [www.vallartayachts.net](http://www.vallartayachts.net) for our complete inventory of more than 60 quality yachts.



60' Hatteras, 1984 ~ She's a 10!



57' Angel Marine, 1990



52' Tayana, 1991



50' Centurion, 1984



42' Catalina ~ 4 to choose from



42' Hunter Passage, 1993

Nick and Carol Rau  
Paradise Village Marina

[www.vallartayachts.net](http://www.vallartayachts.net)  
[nick@vallartayachts.net](mailto:nick@vallartayachts.net)

Toll Free: 866-578-2636  
Ph/Fax: 011-52-322-297-2249  
Local Cell: 044-322-227-2944  
US: 314-667-4111 (rings in MX)

## SPECIAL FEATURED BOAT



**39' ISLAND PACKET 380, 2001**  
**IMMACULATE!**

*Exclusive  
Mexico Dealer  
for Sabre and  
Back Cove Yachts*



VALLARTA YACHTS S.A. DE C.V.



## McGinnis Insurance

Since 1972

**Knowledge ⚓ Commitment**  
**Reliability ⚓ Service**



*Large and small, we do them all!*

Call us at: **800-486-4008**

[mcginnisins@aol.com](mailto:mcginnisins@aol.com)

License #0570469



## RICHARDSON BAY MARINA

formerly Kappas Marina

**MODERN FACILITIES IN A WELL-PROTECTED HARBOR**

**Concrete  
Dock System**

**Well Maintained  
Facilities**

**Beautiful  
Surroundings**

- DEEP WATER BERTHS:  
BASIN AND CHANNEL  
DREDGED
- CARD KEY SECURITY SYSTEM
- DOCK CARTS
- PUMP OUT STATION
- AMPLE PARKING
- CLEAN SHOWER AND  
TOILET FACILITIES
- WITHIN WALKING  
DISTANCE: MARKET/DELI,  
LAUNDROMAT,  
RESTAURANT
- AT EACH BERTH:  
LARGE STORAGE BOX,  
METERED ELECTRICITY,  
PHONE HOOKUPS, WATER

**BERTH YOUR BOAT IN SAUSALITO**

**Phone 415 • 332 • 5510**

100 Gate Six Road, Sausalito • Fax (415) 332-5812



# BETA MARINE

Our engines idle smoother and quieter because of our high inertia flywheel. This is one of the many Beta Marine exclusive features that make our diesel engines easier to live with.



SMOOTHER...  
QUIETER!

**What a Concept! It is engineered to be easily serviced.**

Beta Marine superb propulsion engines, using Kubota diesel 10-90hp including our famous Atomic 4 replacements.

Also available: Marine Generators up to 30 kw.

Come visit us at our new waterfront location!

**HIRSCHFELD YACHT LLC**

39 Libertyship Way, Sausalito, CA 94965  
www.engineerite.com • www.betamarinewest.com  
**(415) 332-3507**

# We Won't Hand You a Line



## The Right Rope for Every Application—In Stock!

Whether you race or cruise, we've got the right line to make every system on your boat run smoother, stronger and more efficiently. And our rigging experts have the knowledge to match precisely the right line to every need. For the best selection of line, from affordable, all-around polyester braid, to the most advanced high-tech cordage, visit the Rigging Shop at our Alameda store location and find out what the right rope can do to make your sailing smoother, swifter and more fun!

**West Marine**  
We make boating more fun!

Visit our **Alameda Sailing Superstore!**  
730 Buena Vista Ave. • 510-521-4865

We have 22 stores in Northern California.  
Log onto [westmarine.com](http://westmarine.com) or call **1-800-BOATING**  
to find the store nearest you.

**HONDA MARINE**  
IT'S ALL ABOUT POWER.

**caribe**  
INFLATABLES

**Aquapro**  
INFLATABLES



**TOHATSU**  
outboards

**Achilles**

We've been **THE Bay Area authority for inflatables and outboards for more than 35 years.**

Call us today for quotes.

**Voyager Marine**

1296 State St.  
P.O. Box 246, Alviso, CA 95002-0246  
**(408) 263-7633 • (800) 700-7633**  
Open Tuesday thru Saturday



# SAIL HOME TO PARADISE



No channel to access one of the most desirable parts of the Bay with amazing anchorages in the sheltered beachfront coves of Tiburon's Gold Coast.

- ★ Deep water berthing for boats up to 110-ft.
- ★ On Tiburon's Gold Coast.
- ★ Two miles to Paradise Park and five miles to Angel Island.
- ★ Six miles to Sam's and downtown Tiburon.
- ★ New beautiful Tiburon Yacht Club with Friday Night Racing.
- ★ Flat water and warm breeze.
- ★ Tiburon's gourmet market and shopping nearby.
- ★ Affordable guest berthing for boats up to 110'.
- ★ 12 miles to San Francisco.
- ★ Marin's great restaurants & shopping within 5 miles.

Paradise Cay Yacht Harbor is now accepting berthing applications for boats of all sizes. Give us a call!

## Paradise Cay Yacht Harbor

[www.paradisecayyachtharbor.com](http://www.paradisecayyachtharbor.com) • Trinidad Drive, Tiburon

415.435.4292

## Wright Way designs

Custom Yacht Interiors

**PROFESSIONAL DESIGN  
SERVICES INCLUDE  
CUSTOM**

carpeting  
cushions  
designer fabrics  
draperies  
linens  
upholstery



**Deborah Wright**  
510.908.3939

2900 Main Street #67, Alameda, CA 94501

[wrightwaydesigns@hotmail.com](mailto:wrightwaydesigns@hotmail.com)

Check out our new web site:

[www.wrightwaydesigns.com](http://www.wrightwaydesigns.com)



## Newest Technology for Bottom Paint Stripping Offered by Surface Restoration Group

- ◆ Using the Farrow System® designed for use in boatyards and marinas to strip paint from Fiberglass, Wood, Steel and Aluminum hulls for supreme paint adhesion.
- ◆ Remove years of paint coatings for better performance and speed. Reduced drag, weight, and increased fuel savings.
- ◆ Fast – Cost Effective – Green Technology – Precise Control.

Visit website or call for further information

[www.surfacerestorationgroup.com](http://www.surfacerestorationgroup.com)

925 998-9902



CRUISE OR SAIL OVER TO OUR NEW WEB-SITE AT  
[www.californiaboatersguide.com](http://www.californiaboatersguide.com)

EDITION NO. 17 THE CALIFORNIA BOATER'S GUIDE YEAR 2005-2006  
 to the HARBORS & MARINAS of the San Francisco Bay, Delta, Outer Coast & Hawaii

SOME FEATURES -  
 • LOCATION  
 • TELEPHONE  
 • FAX & E-MAIL  
 • WEB-SITES  
 • GPS WAYPOINT  
 • GUEST BERTHS  
 • LAUNCH RAMP  
 • PUMPOUT  
 • FUEL DOCK  
 • RESTROOMS  
 • LAUNDRY  
 • SHOWERS  
 • FOOD & SUPPLIES  
 ...and much more

2005/2006 17th EDITION

WILD ONES CALIFORNIA

NOW YOU CAN BUY A BOOK ONLINE

LISTING OVER 250 HARBORS & MARINAS & DETAILING OVER 115

# Functional Gear, Fantastic Value!



## Third Reef Foul Weather Gear

A perennial best-seller, our 5th generation Third Reef Foul Weather Gear is now better than ever. It's totally waterproof, breathable, built to last and packed with the kind of comfort features you'd expect to find only on much more expensive gear. It's available in both Men's and Women's sizes in Jackets, Bibs and Women's Drop Seat Bibs. For bashing around the Bay, or cruising along the coast, you won't find better gear at a better price. Available at all West Marine stores or online at [westmarine.com](http://westmarine.com).

Jackets **\$109.00**

Bib Pants **\$90.00**

**West Marine**  
 We make boating more fun!

Visit our **Alameda Sailing Superstore!**  
 730 Buena Vista Ave. • 510-521-4865

We have 22 stores in Northern California.  
 Log onto [westmarine.com](http://westmarine.com) or call **1-800-BOATING**  
 to find the store nearest you.

LIVE AND IN PERSON!

## The Legends of Sailing

Sponsored by KKKMI  KEEFE KAPLAN MARITIME, INC.

**OCTOBER 2 ~ James Martin**  
 Adventurer, Author, Photographer  
 "The Islands of San Francisco Bay"

**6-9 p.m. • FREE!**

For more information and to RSVP,  
 visit [www.cyc.org/speakers](http://www.cyc.org/speakers)  
 or call **(415) 435-4771**

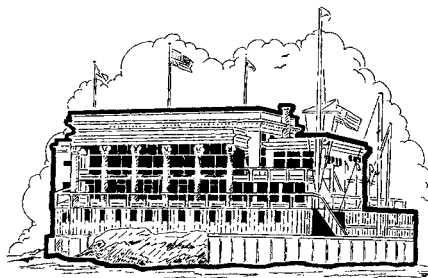

## Corinthian Yacht Club

OF SAN FRANCISCO

43 MAIN, TIBURON, CA 94920 • [www.cyc.org](http://www.cyc.org)





# CLIMB ABOARD!

*AGAIN and AGAIN and AGAIN*

Discover over 300 boats – including cabin cruisers, sport boats, sailboats, and mega-yachts. Plus, see the *Sea Star* from TV's "Deadliest Catch" and meet her crew!

SPONSORED BY:



**Fireman's Fund**  
Insurance Company

10am - 6pm  
\$10 for ADULTS  
\$5 for CHILDREN  
\$18 for MULTI-DAY PASSES

**BOATS AFLOAT SHOW 2008**  
SEPTEMBER 10-14  
LAKE UNION • SEATTLE  
[BOATSAFLOATSHOW.COM](http://BOATSAFLOATSHOW.COM)

Produced by Northwest Yacht Brokers Association  
Supported by Northwest Marine Trade Association

## SEA FROST®



### COOL IT YOURSELF!

Refrigeration has never been easier. Sea Frost's compact and powerful, 12-volt BD refrigeration conversion kit comes pre-charged and ready for owner installation.

**Sea Frost... Quality at an affordable price!**

**Local Dealers:**

Anderson Refrigeration Co. \* Alameda, CA  
(510) 521-3111

---

Poole Refrigeration Service \* Alameda, CA  
(510) 523-3495

[www.seafrost.com](http://www.seafrost.com)



## OYSTER POINT Marina/Park



*A full service marina located in South San Francisco with berthing and guest dockage available*

For information and pricing call  
**(650) 952-0808**  
[www.smharbor.com/oysterpoint](http://www.smharbor.com/oysterpoint)



## GET AMERICA'S FINEST BOATING EDUCATION



Location	Phone #	Location	Phone #
Antioch	(925) 377-2628	San Mateo	(650) 592-3604
Marin	(415) 883-6777	Santa Clara	(408) 225-6097
Martinez	(925) 377-2628	Santa Rosa	(707) 793-0538
Monterey Bay	(831) 624-3333	Stockton	(209) 951-3862
Sacramento	(916) 782-1240	Vallejo	(707) 552-6287
San Leandro	(650) 592-3604	Walnut Creek	(925) 377-2628

[www.usps.org/localusps/d25/squadrons](http://www.usps.org/localusps/d25/squadrons)

## BOAT LOANS

Unbeatable rates.

**New / Used / Refinance**

Call us today  
for a free quote.

**(800) 233-6542**

San Diego, Newport Beach, Alameda & Seattle



[www.seacoastmarine.net](http://www.seacoastmarine.net)

A division of Seacoast National Bank.

# Relieves Gas Pains

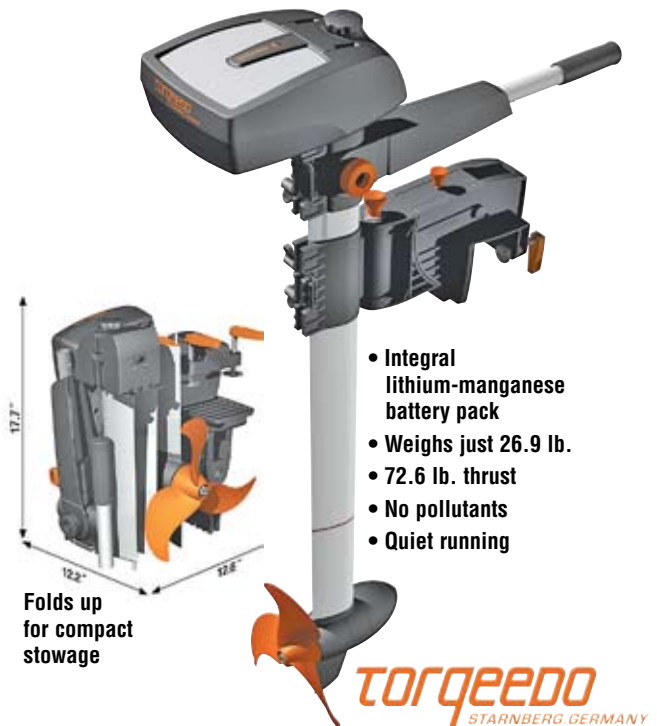

Folds up  
for compact  
storage

- Integral lithium-manganese battery pack
- Weighs just 26.9 lb.
- 72.6 lb. thrust
- No pollutants
- Quiet running

**torqeedo**  
STARNBERG GERMANY

## Travel 801 Electric Motor

Finally! A practical alternative to gas-powered outboards that's ideal for tenders, small keelboats and sportboats. The Torqeedo Travel 801 eliminates the mess and potential hazards of gas tanks along with oil changes, tune-ups, fumes and that infernal racket.

The Torqeedo combines an advanced lithium-manganese battery, highly efficient synchronous permanent magnet motor and variable pitch prop to produce thrust equivalent to a 2 hp combustion motor. It weighs a mere 26.9 lb. (with battery) and can be folded for easy stowage and transport.

If you're ready to say good-bye to gas pains, say hello to a better propulsion solution—the Torqeedo Travel 801 Electric Motor.

Long & Short Shaft versions available.

**West Marine®**  
We make boating more fun!®

Visit our **Alameda Sailing Superstore!**  
730 Buena Vista Ave. • 510-521-4865  
We have 22 stores in Northern California.  
Log onto [westmarine.com](http://westmarine.com) or call **1-800-BOATING**  
to find the store nearest you.

# Caltopia 2008

September 12-14

Richmond Yacht Club



## Third Annual Celebration of Cal Boats

Friday and Saturday  
evening dockside reception  
with complimentary beer!

Polish up your Cal  
for viewing of open  
boats.

Buy & sell Cal stuff  
at Caltopia swap  
meet Saturday  
morning.

Sail your Cal in the  
All-Cal Parade Saturday  
afternoon.

Attend seminars about Cal boats.

Saturday dinner: Prime rib or BBQ  
plus evening jazz at RYC.

No charge to register; no charge to stay  
overnight.

Bring your Cal boat to Richmond Yacht Club  
September 12-14 and join the festivities!

For more information, contact  
Mike at (916)705-3200.



# CALENDAR

## Non-Race

**Sept. 1** — The unofficial end of the season: Labor Day.

**Sept. 1** — Celebrate Labor Day with "Songs of Sea Labor" with sea music performers Holdstock & Macleod aboard *Balclutha* at Hyde Street Pier, 12-1:30 p.m. \$5 admission. Info, [www.nps.gov](http://www.nps.gov).

**Sept. 3-24** — Wednesday Yachting Luncheon Series at St. Francis YC, 12-2 p.m., \$13.50. Enjoy lunch and a dynamic speaker every Wednesday. All YCs' members welcome. More info under the 'Events' tab at [www.stfyc.com](http://www.stfyc.com).

**Sept. 3-Oct. 1** — Intro to Boating class by Agate Pass Sail & Power Squadron in Poulsbo, WA, on Mon. and Weds., 6:30-9 p.m. Info, contact Marty at [apsnps@yahoo.com](mailto:apsnps@yahoo.com) or (360) 697-5008 or go to [www.usps.org/localusps/agatepass](http://www.usps.org/localusps/agatepass).

**Sept. 5-7** — 32nd Annual Wooden Boat Festival in Port Townsend, WA. "The Woodstock for wooden boat lovers." Info, [www.woodenboat.org](http://www.woodenboat.org).

**Sept. 6** — Marina Village Yacht Harbor Gate 11 Nautical Swap Meet in Alameda, 9 a.m.-1 p.m. No vendors, please!

**Sept. 6** — All About Cruising Mexico seminar by Dick Markie, harbormaster of Paradise Village in Nuevo Vallarta, 1 p.m. at the Sausalito West Marine. Info, (415) 332-0202.

**Sept. 6-14** — Northern California Fall Boat Show at Jack London Square in Oakland. Info, [www.ncma.com](http://www.ncma.com).

**Sept. 7, 21** — Cal Sailing Club will give free sailboat rides at Berkeley Marina, 1-4 p.m. Info, [www.cal-sailing.org](http://www.cal-sailing.org).

**Sept. 7-28** — Free sailing at Pier 40 every Sunday courtesy of BAADS. Info, (415) 281-0212 or [www.baads.org](http://www.baads.org).

**Sept. 9** — All About Cruising Mexico seminar by Dick Markie, harbormaster of Paradise Village in Nuevo Vallarta, 5:30 p.m. at the Oakland West Marine. Info, (510) 532-5230.

**Sept. 9-25** — Boating Course by Marin Power & Sail Squadron in Novato on Tues. and Thurs., 7-9 p.m. Textbook \$50. Info, (415) 924-2712.

**Sept. 9-Nov. 10** — Sailing Skills & Seamanship class by Flotilla 12-2 at Oakland YC on Tuesday nights, 6:30-8:30 p.m. \$55 fee. Call Nancy at (510) 601-6239 for reservations.

**Sept. 10** — *Latitude 38's* Mexico-Only Crew List Party & Baja Ha-Ha Reunion at Encinal YC, 6-9 p.m. \$7 (free for skippers and first mates registered for the 2008 Ha-Ha). Info, (415) 383-8200 or [www.baja-haha.com](http://www.baja-haha.com).

**Sept. 10-14** — Lake Union Boats Afloat Show in Seattle. Info, [www.boatsafloatshow.com](http://www.boatsafloatshow.com).

**Sept. 11** — Single sailors of all skill levels are invited to the Single Sailors Association monthly meeting at Oakland YC, 6:30 p.m. Info, [www.singlesailors.org](http://www.singlesailors.org) or (510) 233-1064.

**Sept. 12-14** — Caltopia 2008, the Bay's annual Cal rendezvous at Richmond YC. Info, [www.calboats.org](http://www.calboats.org).

**Sept. 13** — Encinal YC's Nautical Swap Meet. Breakfast, lunch and beverages available, 6 a.m.-1 p.m. Info, (510) 522-3272 or [www.encinal.org](http://www.encinal.org).

**Sept. 13** — All Islander Rendezvous and Fun Race, co-hosted by OYC and EYC on the Estuary. Info, [www.islander36.org/allislander08details.html](http://www.islander36.org/allislander08details.html).

**Sept. 15** — Full moon on a Saturday night.

**Sept. 17** — SF Maritime National Historic Park's Sea Music Concert aboard *Balclutha* at Hyde St. Pier, 8 p.m. Enjoy Geoff Kaufman's performance as he leads you to find truth, humor and beauty in traditional music. \$14. Info, (415) 561-7170.

**Sept. 17, 1901** — Sir Francis Chichester's birthday.

**Sept. 19** — History of the *USS Potomac*, FDR's yacht that is often seen on the Bay. Presentation at Oakland YC at 7:45, free. Come early for dinner. Reservations, (510) 522-6868 or [emendes@oaklandyachtclub.com](mailto:emendes@oaklandyachtclub.com).



# Your Baja Ha-Ha Outfitters!

## Sausalito —

295 Harbor Dr (415) 332-0202

### Michael Price

Michael has been boating for almost 50 years and has owned a total of 23 vessels (both sail and power), 11 of which he built from the keel up. Before his current 20 year stint with West Marine, Michael was a partner in Anchorage Marine in Sausalito for 10 years. When it comes to maintenance, electrical, plumbing and power, Michael is the "go-to" source for his large following of loyal customers.

### Jeff Zarwell

Jeff has been racing on San Francisco Bay for over 25 years and now manages over 90 days of racing each year around the country as a "Certified National Race Officer." Jeff's certification by the United States Sailing Association qualifies him to be the Principal Race Officer of virtually any regatta in the world. In addition to racing, Jeff has also cruised the West Coast and the Caribbean. Jeff has expert knowledge of running rigging for racing and cruising, anchoring, navigation, foul weather gear and electronics.

## Alameda — Dan Niessen

730 Buena Vista Av. (510) 521-4865

Dan Niessen comes to West Marine with over 25 years of sailing experience. After competing in the Pac-10 college sailing circuit, he moved up to racing J-Boats, 505s and FDs in the San Francisco Bay Area. Dan currently owns 2 boats and is an avid long distance cruiser and a certified sailing instructor.

## Long Beach — Holly Scott

251 Marina Dr. (562) 598-9400

Holly's love of boats and sailing began at the age of nine, when she found a fully rigged Sabot in the living room. By the age of 15 she was skippering her parent's Cal 36 to Catalina and up and down the California coast and bought her very own cruising sailboat at the age of 24. Today Captain Holly has a 100-ton Masters License and charters all over the world. Holly loves to share her knowledge, experience and boating humor.

## Newport Beach — Louis Holmes

900 West Coast Highway (949) 645-1711

Louis has been an avid sailor for 22 years. Starting in sabots, he has sailed in regattas ranging from Dinghy and Olympic One Design, to Grand Prix and Offshore events. He has over 6000 miles of delivery experience, including two Mexico returns and a return from Hawaii, and over 10,000 miles of racing experience. Louis is most at home charging down waves or slogging around the next point. Now in his tenth year at West Marine, Louis is eager to tackle your rigging, electronics, and navigational needs to make your boat faster, safer, and easier to sail. Stop into our Newport Beach location to talk to Louis or the many other knowledgeable associates about outfitting your boat for the Baja Ha Ha.

## San Diego — Mick Fritzching

1250 Rosecrans (619) 225-8844

Mick has been sailing since he was a small boy. He started out sailing Thistles, Comets, and Lightnings on the finger lakes in upstate New York and built his first sabot out of plywood with his dad when he was 11 years old. Their family yacht was a 60' Alden that his father salvaged off the Jersey shore and completely rebuilt. Mick, along with his wife and son, have cruised on and off for many years, and he is currently restoring a 1967 Columbia Constellation.



Sausalito



Alameda



Long Beach



Newport Beach

San Diego



380 Stores Nationwide  
1-800-BOATING  
westmarine.com

 **West Marine**<sup>®</sup>  
We make boating more fun!<sup>®</sup>

# CRUISERS!

## Head for Downwind Marine!

### CRUISER SEMINARS

Meeting at Point Loma Assembly Hall  
3035 Talbot St. at 7:30 pm. \$3/person

- Fri 10/3 TBA
- Tues 10/7 **Surviving a Haul Out**, Koehler Kraft
- Tues 10/14 **Beyond Mexico: Preparing and Cruising the South Pacific**, Sam and Sally Peterson
- Fri 10/17 TBA
- Tues 10/21 **Cruising the Sea of Cortez**, Heather Bansmer & Shawn Breeding
- Fri 10/24 **Cruising Mexico with Charlie**, Margo Woods, Charlie's Charts
- Tues 10/28 **Staying Friends with Your Diesel Engine**, Koehler Kraft
- Thurs 11/6 **Cruising Self-Sufficiency**, Paul Mitchell, Circumnavigator  
**Cruising Women's Round Table Discussion**, Susan Mitchell, Circumnavigator
- Tues 11/11 **Cruising on 12 Volt Batteries, Alternators, Invertors: Tips and Troubleshooting**, Altra Regulators
- Thurs 11/13 **Offshore Marine Safety: Life Rafts, EPIRBs and Beyond**, Bruce Brown, Certified USCG Trainer
- Tues 11/18 **Under Pressure! Pressure Cooking for Cruisers**, Captain Steve Ford, Author & Veteran Cruiser
- Thurs 11/20 **AIS: The Best Collision Avoidance System**, Steven Gloor, GTS Consulting, Veteran Cruiser



### SPECIAL EVENTS

- Mon 10/20 **Special Baja Ha-Ha Sponsor Day** at Downwind Marine. Tune up your cruising gear. See [www.downwindmarine.com](http://www.downwindmarine.com) for details.
- Thurs 10/23 **Sailmail Marine Communication Seminar** 8:30am-4:00pm, Point Loma Assembly Hall \$50/person or \$75/couple includes lunch
- Sun 11/9 **Downwind Cruisers' Kick-Off Potluck BBQ**, 12-4pm at Shelter Island Beach near launch ramp. We bring beer, sodas, burgers & hot dogs. Cruisers bring salad, side dish or dessert to share. Moves to store in event of rain.
- 11/10-15 **Downwind Cruisers Week** Wholesale discount prices everyday, all week long for all customers.

[www.downwindmarine.com](http://www.downwindmarine.com)



Open: M-F 8-5 • Sat. 9-5

(619) 224-2733 • TOLL FREE (866) 289-0242

2804 Cañon St., San Diego, CA • email: [info@downwindmarine.com](mailto:info@downwindmarine.com)  
CRUISERS' NET, Ch. 68, from 8:30 am weekdays: WHX369

*Boating is  
already Fun –  
We make it more  
Affordable®*

# CALENDAR

**Sept. 20** — California Coastal Cleanup Day, 9 a.m.-noon. Pre-register or show up at the nearest drop-in site to do your part to keep our beaches clean. Info, (800) COAST4U, [coast4u@coastal.ca.gov](mailto:coast4u@coastal.ca.gov) or [www.coastalcleanup.org](http://www.coastalcleanup.org).

**Sept. 22** — Autumnal equinox, aka: the first day of fall.

**Sept. 24** — Modern Sailing and KQED present a screening of *Quest: The Physics of Sailing* at GGYC, 6:30 p.m. Free!

**Sept. 25** — *Rubber Boots on the Red Carpet* premiere, a documentary celebrating 10 years of the Tall Ship Semester for Girls, 6-9 p.m. at Delancey Street Foundation in San Francisco. Info, [www.tallshipacademy.org](http://www.tallshipacademy.org).

**Sept. 27** — 9th Annual Cheoy Lee Rendezvous at Ayala Cove. All makes and models invited. Info, Sue or Brent at [brentsue@inreach.com](mailto:brentsue@inreach.com) or (415) 454-3234.

**Sept. 27** — Glen Cove YC's Nautical Flea Market, 8 a.m. Info, [www.glencoveyachtclub.net](http://www.glencoveyachtclub.net).

**Sept. 27** — 12th Annual PICYA Wheelchair Regatta, a powerboat cruise for disabled U.S. veterans followed by a picnic at Encinal YC. Info, [www.picya.org](http://www.picya.org).

**Sept. 28** — Modern Sailing School & Club's first annual Sail Fest in Sausalito, 11 a.m.-5 p.m. Sailboat rides (with RSVP), guest speakers, music, food and boat show. Free! Info, (415) 331-8250.

**Sept. 30-Oct. 20** — Safe Boating Course by Santa Clara Power Squadron at Wilcox HS on Tuesdays, 7-9 p.m. Materials \$30. Info, (408) 225-6097.

**Oct. 9-14** — Fleet Week, including the Blue Angels. The sailors are in! Details, [www.fleetweek.us](http://www.fleetweek.us).

**Oct. 11-12** — 16th Annual Northern California Women's Sailing Seminar with keynote speaker Linda Newland at Island YC. Info, [www.iyc.org/wss.htm](http://www.iyc.org/wss.htm).

**Oct. 18** — Martinez Marina Nautical Swap Meet, 8 a.m.-noon. Spaces are free! Info, (925) 313-0942.

**Oct. 18** — SF Maritime National Historic Park's Sea Music Concert Series aboard *Balclutha* at Hyde St. Pier, 8 p.m. Enjoy Ida Red's harmonies and acoustic arrangements. \$14 tickets. Info, (415) 561-7170.

**Oct. 19** — Ha-Ha Welcome to San Diego Party at Downwind Marine, 12-4 p.m. Info, [www.baja-haha.com](http://www.baja-haha.com).

**Oct. 27** — Baja Ha-Ha 'Fabulous Fifteen' Cruisers Rally starts from San Diego!

### Racing

**Sept. 5-7** — Moore 24 Nat'l's. RYC, [www.richmondyc.org](http://www.richmondyc.org).

**September, 1978** — It Was Thirty Years Ago, from the article *Moore 24 Nationals*:

After three races, it was time to piggie and party. The crowd of hundreds patiently waited and waited for the pig to get through with its cooking thing, whiling away the time with kegs and kegs of beer. But when the pig was done, it was gone! They say they're vegetarians down in Santa Cruz but they're not. It would have taken a herd to feed that crowd.

After all the piggies had made hogs of themselves, it was time for the Ron Moore Show. The band tried to warm up the crowd but almost got stoned — the crowd wanted Ron. Finally, he took the platform in his best Grease outfit with cigarettes rolled up in his sleeve. Several girls swooned.

Having sailed, piggied, drank, and been educated, Ron decided it was time to party. He leaped to the floor, did a few John Revolta pelvic pumps and the place went nuts. The band hadn't hit two chords when we were almost trampled as the herd of dancers fought their way to the floor of the Santa Cruz YC. They all had T.D. — Terminal Disco!

**Sept. 6** — YRA-ODCA Fall 3. SYC, [www.yra.org](http://www.yra.org).



*Santa Cruz*  
— Y A C H T S —

**SC 37**  
**Arriving**  
**in September!**

**FAST is Fun!**

And a whole lot more.



New SC 37



<b>KERNAN</b>		<b>KERNAN</b>	
<b>SC 37 SPECIFICATIONS</b>		<b>SC 43 SPECIFICATIONS</b>	
LOA	37.00 ft	LOA	43.00 ft
LWL	34.75 ft	LWL	41.07 ft
Beam	10.64 ft	Beam	12.00 ft
Draft	7.50 ft Std.	Draft	10.00 ft Std.
	6.00 ft Shoal	Displacement	12,750 lbs.
Displacement	8,514.00 lbs.	Ballast	6,050 lbs.
Ballast	3,930.00 lbs.	Limit of Positive Stability	143.00°
Limit of Positive Stability	142.00°	Sail Area	998 ft²
Sail Area	717 ft²		

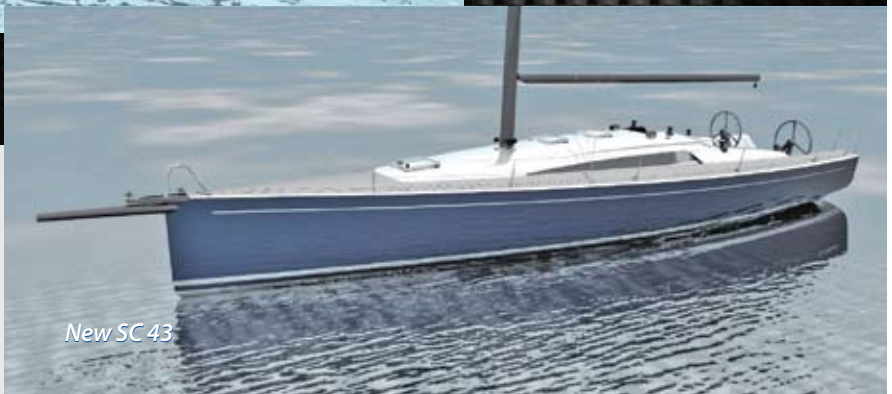

New SC 43

- Strong 100% Carbon Hull and Deck*
- Innovative Lifting Keel*
- Computerized Construction Techniques*
- Modern Eye Catching Styling*
- Race or Cruise-Fast!*

*Presenting the new SC 37 and SC 43.* We've taken state of the art technologies usually reserved for high priced custom boats and brought them all together to create yachts like no other company can build. Our cutting edge technologies give you stellar performance, more value and a lot more easy sailing fun.

Whether it's around the buoys, racing to Hawai'i or Bermuda, or just going to spend more time at that special anchorage with family and friends-sail fast, sail fun with a Santa Cruz.

**Newport Beach**  
251 Shipyard Way,  
Cabin A  
Newport Beach, CA 92663  
sailcaljt@aol.com  
**949-675-8035**

*Dealer for Santa Cruz Yachts in California*

**SAIL**  
*California*

**Alameda**  
1070 Marina Village  
Parkway #108  
Alameda, CA 94501  
info@sailcal.com  
**510-523-8500**

[www.santacruz-yachts.com](http://www.santacruz-yachts.com)

[www.sailcal.com](http://www.sailcal.com)

# SABRE Yachts

offered by

**SAI** California

## SABRE SPIRIT



The 36' Sabre Spirit is elegantly designed to incorporate classic aesthetics and blending youthful, sport-boat performance with 'grown-up' ease of handling. A tall order but masterfully accomplished by designer Jim Taylor and the craftsmen at Sabre.

## SABRE 386



The 396 is another Jim Taylor/Sabre collaboration winning the 'Best Midsize Performance Cruiser' from *Cruising World* upon her introduction. Superior quality with exceptional performance and comfort. See her at our docks.

## SABRE 426



The queen of the Sabre fleet, the 426 incorporates the best of legendary Sabre quality and performance. If you haven't looked closely at a Sabre, you haven't seen the potential of the modern performance cruiser.

**SAI** California

Web page: [www.sailcal.com](http://www.sailcal.com)  
Email: [info@sailcal.com](mailto:info@sailcal.com)

NEWPORT BEACH  
(949) 675-8053  
FAX (949) 675-0584

ALAMEDA  
(510) 523-8500  
FAX (510) 522-0641

## CALENDAR

**Sept. 6** — Singlehanded Sailing Society's Richmond-South Beach Race. SSS, [www.sfbaysss.org](http://www.sfbaysss.org).

**Sept. 6** — Governor's Cup on Folsom Lake, [www.flyc.org](http://www.flyc.org).

**Sept. 6** — Double Angle Race. Start in Santa Cruz or Monterey and finish at Moss Landing. Elkhorn YC, (831) 566-2009 or [www.elkhornyc.com](http://www.elkhornyc.com).

**Sept. 6-7** — West Marine Fun Regatta for junior sailors. SCYC, [www.scyc.org](http://www.scyc.org) or [funregatta@comcast.net](mailto:funregatta@comcast.net).

**Sept. 6-7** — Velocitek Melges Regatta, for Melges 24s and 32s. TYC, Peter Schoen, (415) 720-0634 or [segler@sonic.net](mailto:segler@sonic.net).

**Sept. 11-14** — 44th Rolex Big Boat Series, always the highlight of the local sailing season. StFYC, [www.stfyc.com](http://www.stfyc.com).

**Sept. 16-20** — The Mallory Cup, US Sailing Men's Championship sailed on J/24s. SFYC, [www.sfyc.org](http://www.sfyc.org) or [www.us-sailing.org](http://www.us-sailing.org).

**Sept. 20** — YRA-OYRA Crewed Farallones race. SFYC, [www.yra.org](http://www.yra.org).

**Sept. 20** — Fall Series #1. SSC, [www.stocktonsc.org](http://www.stocktonsc.org).

**Sept. 20** — Wallace Cup, a PHRF championship for East Bay clubs. OYC, [www.oaklandyachtclub.com](http://www.oaklandyachtclub.com).

**Sept. 20** — Ruth Gordon Schnapp Regatta, a fundraiser for Susan G. Komen for the Cure that requires a woman to be at the helm. GGYC, [www.ggyc.com](http://www.ggyc.com).

**Sept. 20-21** — Catalina 34 National SF Cup. Race and cruiser divisions. SBYC, [cowen@meriwest.com](mailto:cowen@meriwest.com).

**Sept. 20-21** — Totally Dinghy Regatta. RYC, (510) 237-2821 or [www.richmondyc.org](http://www.richmondyc.org).

**Sept. 27** — Jack & Jill Race (rescheduled from February). CPYC, [www.cpyc.com](http://www.cpyc.com).

**Sept. 27-28** — YRA Season Closer 1 & 2/Crazy 8 Race. CYC, [www.yra.org](http://www.yra.org).

**Sept. 27-28** — WylieCat Worlds. Aeolian YC, [www.aeolianyc.com](http://www.aeolianyc.com).

**Sept. 27-Oct. 3** — A-Cat NAs. SCYC, [www.scyc.org](http://www.scyc.org).

**Sept. 27-Oct. 4** — IOD Worlds. SFYC, [www.sfyc.org](http://www.sfyc.org).

**Oct. 4-5** — SSS Vallejo 1-2, a mellow way to end the short-handed season. Info, [www.sfbaysss.org](http://www.sfbaysss.org).

**Oct. 4-5** — XOJET SF Leukemia Cup Regatta, PHRF and one design racing to benefit the Leukemia and Lymphoma Society. Hosted by SFYC. Info, [www.leukemiacup.org/SF](http://www.leukemiacup.org/SF).

**Oct. 4-5** — Islander 36 Nationals. GGYC, [www.ggyc.org](http://www.ggyc.org).

**Oct. 5** — El Toro Stampede. RYC, [www.richmondyc.org](http://www.richmondyc.org).

**Oct. 10-12** — International Master's Regatta, a J/105 regatta/reunion for seniors. StFYC, [www.stfyc.com](http://www.stfyc.com).

**Oct. 11-12** — YRA-HDA Yankee Cup. IYC, [www.yra.org](http://www.yra.org).

**Oct. 11-12** — YRA-ODCA Champion of Champions. IYC, [www.yra.org](http://www.yra.org).

**Oct. 11-12** — Olympic Finn Pre-Nationals hosted by Coyote Point YC. Robert Carlen, (831) 336-2672 or [carlen@jps.net](mailto:carlen@jps.net).

**Oct. 11-12** — South Bay Championship. SeqYC, [www.sequoiayc.org](http://www.sequoiayc.org).

**Oct. 12** — 28th Annual Women Skippers Regatta to benefit youth sailing. SYC, [www.syc.org](http://www.syc.org) or [lareenie@yahoo.com](mailto:lareenie@yahoo.com).

**Oct. 18-19** — Jessica Cup, fleet racing for big woodies. StFYC, [www.stfyc.org](http://www.stfyc.org).

**Oct. 25-26** — Great Pumpkin Regatta, a Halloween tradition. RYC, [www.richmondyc.org](http://www.richmondyc.org) or (510) 237-2821.

### Remaining Beer Can Regattas

**BALLENA BAY YC** — Friday Night Grillers: 9/5, 9/19, 10/3, 10/17, 10/31. Dan or Kelly, [race@bbyc.org](mailto:race@bbyc.org).

**BAY VIEW BOAT CLUB** — Monday Night Madness Summer Series: 9/1, 9/15, 9/22. Peter McCool, (415) 864-4334 or [bayviewracing@sbcglobal.net](mailto:bayviewracing@sbcglobal.net).

**BENICIA YC** — Thursday nights through September. Bill



**WE WANT TO SELL YOUR BOAT! CALL TODAY – DOCK SPACE AVAILABLE!**

# SAIL *California*

Your go-to dealer for performance boats and top of the line cruising boats, we represent **J/Boats, Santa Cruz Yachts, Sabre, and Back Cove Yachts.**

**J/120, 2001**

**OuiB5**

One of North America's most successful Big Boat One-Design, the J/120 is the most versatile 40 footer afloat. See **OuiB5** on our sales dock. Asking **\$229,000**



**Andrews 56, 1994**

**Charisma**

This performance cruising boat offers speed and comfort with the allure for adventure. Call today to fulfill your cruising dreams. Asking **\$364,599**



**70' Custom Wylie**

**Rage**

The ultimate first-to-finish performance cruiser! Asking **\$598,000**



**45' Hunter 450, 2000, Fall Asea**

Priced to sell, ultimate cruiser and/or live-aboard. Palatial interior (standing headroom over 6.5'), large cockpit, great swim platform, spacious decks. Ready for year-around fun. Asking **\$199,000**



**Ron Holland 43, 1984, Azure-Te**

This boat is amazing: great set-up, impeccable maintenance, turn-key cruiser. This is a lot of boat for the money – call today. Asking **\$149,000**



**Express 34, 1987**

The perfect small racer/cruiser. Asking **\$68,900**



**SISTERSHIP**

**J/105, 2001, Anna Laura**

Race ready or weekend daysailer, the J/105 is the boat for you. Asking **\$119,999**



**Bianca 414, 1980, Avion**

Elegant sailing boat, traditional and beautiful, need we say more? Asking **\$58,000**

70' Custom Wylie, <i>Rage</i> .....	\$598,000	37' J/37, '88, Hull #30**.....	\$105,000	34' MJM 34z, '05.....	\$399,000
56' Andrews, '94, <i>Charisma</i> .....	\$364,599	37' Beneteau First 375, '85, <i>Time Warp</i> **.....	\$69,900	34' Express, '87.....	\$68,900
48' Kristen, '01, <i>Trinity</i> .....	\$629,000	36' J/109, '03, <i>Queen Bee</i> .....	\$215,500	34' Pacific Seacraft, '89, <i>Credence II</i> .....	SOLD \$89,900
45' Hunter 450, '00, <i>Fall Asea</i> .....	Reduced! \$199,000	36' Sydney, '06, <i>Encore</i> .....	\$325,000	30' J/92, '93, <i>Zippy</i> , Waukesha, WI.....	\$54,500
44' J/44, '90, <i>Phoenix</i> .....	\$219,000	35' J/105, '01, Hull #403**.....	SOLD \$115,000	30' Sabre, '86, <i>Buena Vida</i> .....	\$54,500
43' Ron Holland, '84, <i>Azure-Te</i> .....	\$149,900	35' J/105, '01, Hull #382, <i>Anna Laura</i> .....	\$119,999	29' J/29, '81, <i>Macs</i> *.....	\$26,900
41' Passport, '90, <i>360</i> **.....	Reduced! \$249,900	35' J/105, '99, Hull #265, <i>Tiburon</i> .....	SOLD \$109,900	29' J/29, '84, <i>Jolly J</i> *.....	\$25,000
41' Bianca 414, '80, <i>Avion</i> .....	\$58,000	35' J/105, '99, Hull #255, <i>Roadster</i> **.....	\$105,000	29' Back Cove, <i>Island Chef</i> *.....	SOLD \$199,000
40' J/120, '98, <i>Simply Red</i> *.....	\$199,000	35' J/105, '99, Hull #235, <i>Life Is Good</i> **.....	\$92,000	29' Back Cove, '05, <i>Diamond Lil</i> .....	Reduced! \$189,000
40' J/120, '95, <i>Attitude</i> **.....	\$189,000	35' J/105, '98, Hull #174, <i>Dulcinea</i> **.....	\$89,500	27' Choate, '79, <i>Allegro Con Brio</i> **.....	\$9,900
40' J/120, '01, <i>OuiB5</i> .....	\$229,000	35' One Design, '98, <i>Double Trouble</i> .....	\$94,900	26' J/80, '00, <i>Risky Business</i> **.....	\$32,000
40' Tripp, '92, <i>Snake Oil</i> **.....	\$85,900	34' J/34, '85, <i>The Zoo</i> **.....	Reduced! \$29,900	22' Aquapro Raider 665, '04.....	\$44,900
39' Dehler 39, '03, <i>Wild Redhead</i> **.....	\$329,500				

\* Indicates So. California Boats  
\*\* Indicates Seattle Boats

**YACHTWORLD.com**

**OPEN BOAT WEEKEND  
SEPTEMBER 13-14**

**J  
Net**

# SAIL *California*

Web Site: [www.sailcal.com](http://www.sailcal.com)  
Email: [info@sailcal.com](mailto:info@sailcal.com)

**NEWPORT BEACH**  
251 Shipyard Way  
Cabin A  
Newport Beach, CA 92663  
**(949) 675-8053**  
FAX (949) 675-0584

**ALAMEDA**  
1070 Marina Village Pkwy  
#108  
Alameda, CA 94501  
**(510) 523-8500**  
FAX (510) 522-0641

**SEATTLE**  
**SAIL NORTHWEST**  
7001 Seaview Ave. NW  
Suite 140  
Seattle, WA 98117  
**(206) 286-1004**



# KKMI KH



## An INCREDIBLE Deal!



The same company that's been nationally recognized as Boatyard of the Year, provides you with the highest quality service and delivers un-matched efficiency, KKMI, is now offering an incredible deal!

\$49 per hour for all of these services:

- Buffing ▶ Polishing
- Waxing ▶ Detailing
- Varnishing ▶ WOW!

If your boat looks anything less than perfect, now is the time to take advantage of KKMI's Summer DISCOUNT Boat Maintenance Special. Call us today as space, production and this offer are for a limited time only. Your boat (and marina neighbor) will thank you!

## Winter Projects

What, it's not winter? You're right, but it's not too far away and if you plan ahead you'll secure a spot in one of our hospitable sheds. Call the KKMI office or your project manager and we will lock in your rates, including the summer detailing special! Not only will you lock in savings but we also guarantee your complete satisfaction. Call us today, Shedita, Shed Clampett & Shedy Temple are waiting!





# RONICLE

530 West Cutting Boulevard  
Point Richmond, CA 94804  
Office (510) 235-KKMI (5564)  
Chandlery Ph (510) 237-4141  
www.KKMI.com ▶ yard@kkmi.com



## KKMI Brings Home the Gold, Silver & Bronze!



From left to right: Kim Desenberg, Debbie Castellana, Bob Hennessey

Okay, so the Team didn't really make it to this year's Olympics in Beijing, but if there were an event in Maritime Services, KKMI would've ruled the podium! (*Eat your heart out Michael Phelps*) The KKMI Team, averaging 21 years experience, is made up of the most talented and professional craftsmen in the industry. With skills ranging from rigging and engine mechanics to painting and welding, their Team is confident in meeting if not exceeding your highest expectations.

"I appreciate the professional manner in which you operate your yard," says Steve Sommer owner of the Slocum 43 *Sea Biscuit*. "My yard manager was great, as was the work completed there. Everyone that I was introduced to, or was assigned work to do on my boat was a pleasure to work with; all were customer focused!"

Aside from the incredible people that make up the Team at KKMI, their innovative and highly efficient facility is more than just a "boatyard" but a modern Service Center. Unique features such as the location of the chandlery in the middle of the facility saves valuable time in making repairs. So too does their floating mechanical ServiceShip. Every aspect of their operation is designed with value in mind, making KKMI customers the real winners!

## HERB CRANE



**INSURANCE KLAIMS:** If your boat's been in an accident...first of all, sorry to hear about that...second, let KKMI help get things taken care of. The insurance company lets you choose where to take your boat...right...so why not take your boat to the company known for delivering the highest quality work? At KKMI they'll not only make sure your boat is put back into shipshape but when you resell your boat and disclose you had an "oops", you can also say, all the work was done by the only Northern California Service Center that received the "Award of Excellence" from the American Boat Builder's and Repair's Association. So give KKMI a call with your next insurance claim. They'll help with...what's the saying...turning your lemons in to lemonade.



**NOT A BOOKWORM, BUT A BOATWORM:** If you...or someone you love...is living with a Boatworm...KKMI can help. People suffering from this condition cannot get enough material to read about boats. They often have feelings of loneliness after turning the final page of *Latitude 38*. Those seeking treatment for a Boatworm can now visit [KKMI.com](http://KKMI.com) for relief via their e-newsletter. You'll find articles about all things boating: cool equipment...boat smarts...and news about what's going on around the yard...you or your loved one will feel lost no more. Check out their online help and call us in the morning!



**LIKE A VIRGIN:** Well, not exactly. Bill Erkelens is coming up on what will be his fourth trip across the Atlantic! This time he's aboard the 100' ultimate *Speedboat*, soon to be renamed for her commercial sponsor. This has been quite a project for Bill, from design and construction to her delivery in Newport, R.I this past June. Now, there's another challenge to set a new record across the Atlantic. What a thrill! Certainly KKMI is very fortunate to have Bill on the Team but the real winner without a doubt, are his clients. Whether your dream is to go fast or in luxury, Bill is someone you should talk to before you build or buy a yacht.

# CALENDAR



## RUTH GORDON SCHNAPP REGATTA LADY SKIPPERS' RACE September 20th, 2008

Proceeds donated to  
Susan G. Komen Foundation



## THE ISLANDER 36 NATIONALS October 4th & 5th, 2008

## 38TH ANNUAL MANUEL FAGUNDES SEAWEEED SOUP REGATTA November 1st & December 6th (Race 1 & 2 of the 5 race series)

Join us for these fun-filled races and enjoy the  
greatest view at the friendliest yacht club  
on the bay!

**GOLDEN GATE  
YACHT CLUB** 

ONE YACHT ROAD, SAN FRANCISCO, CA 94123  
**www.ggyc.com • (415) 346-2628**

Watson, (707) 746-0739 or [bill@watsonparty.com](mailto:bill@watsonparty.com).

**BERKELEY YC** — Every Friday night through 9/26. Tom Nemeth, (510) 652-6537 or [tom.nemeth@there.net](mailto:tom.nemeth@there.net).

**CAL SAILING CLUB** — Year-round Sunday morning Lido 14 races, intraclub only. Ed, [racing\\_chair@cal-sailing.com](mailto:racing_chair@cal-sailing.com).

**CORINTHIAN YC** — Every Friday night through 9/5. Donal Botkin, [www.cyc.org/race](http://www.cyc.org/race) or (415) 435-4771.

**COYOTE POINT YC** — Wednesday nights through 10/8. Roger Anderson, (650) 367-7480 or [regatta@cpyc.com](mailto:regatta@cpyc.com).

**ENCINAL YC** — Summer Twilight Series, Friday nights: 9/5, 9/19. Tom, [rearcommadore@encinal.org](mailto:rearcommadore@encinal.org).

**GOLDEN GATE YC** — Friday nights: 9/5. Gary Salvo, (916) 363-4566 or [garysalvo@ggyc.com](mailto:garysalvo@ggyc.com).

**HP SAILING CLUB** — El Toro races on Stevens Creek Reservoir. Every Wednesday night through October 22. See [www.hpsailingclub.org](http://www.hpsailingclub.org) for details.

**ISLAND YC** — Summer Series, Friday nights: 9/12, 9/26. Joanne McFee, (510) 521-7442.

**LAKE TAHOE WINDJAMMERS YC** — Every Wednesday night through 10/29. Mike Robinson, (530) 713-9080.

**MONTEREY PENINSULA YC** — Sunset Series, Wednesday nights through 9/24. Bob Furney, (831) 372-9686.

**OAKLAND YC** — Sweet 16 Midweek Series, Wednesday nights through 9/17. Steve, (510) 373-3280 or [5103733280@grandcentral.com](mailto:5103733280@grandcentral.com).

**RICHMOND YC** — Wednesday nights: 9/3, 9/10, 9/17. Eric Arens, (510) 841-6022 or [www.richmondyc.org](http://www.richmondyc.org).

**SAUSALITO YC** — Summer Sunset Series, Tues. nights: 9/9, 9/23. Paul Adams, (415) 269-1973 or [race@syconline.org](mailto:race@syconline.org).

**SEQUOIA YC** — Every Wednesday night through 10/8. Rick Gilmore, (650) 593-5591.

**VALLEJO YC** — Every Wednesday night through 9/24. Timothy Dunn, [fleetcaptainsail@vyc.org](mailto:fleetcaptainsail@vyc.org).

Please send your calendar items by the 10th of the month to [calendar@latitude38.com](mailto:calendar@latitude38.com). If you're totally old-school, mail them to *Latitude 38* (Attn: Calendar), 15 Locust Avenue, Mill Valley, CA, 94941 or fax them to us at (415) 383-5816. But please, no phone-ins! Calendar listings are for marine-related events that either are free or don't cost much to attend. The Calendar is not meant to support commercial enterprises.

### September Weekend Currents

date/day	slack	max	slack	max
8/30Sat	0105	0417/4.9E	0802	1104/4.1F
	1408	1648/3.4E	2007	2303/3.6F
8/31Sun	0157	0500/4.7E	0841	1139/4.0F
	1441	1726/3.8E	2053	2348/3.7F
9/01Mon	0248	0541/4.3E	0919	1212/3.7F
	1515	1803/4.0E	2138	
9/06Sat	0059	0352/2.2F	0719	0919/1.4E
	1231	1529/1.5F	1815	2141/3.2E
9/07Sun	0206	0508/2.0F	0831	1018/1.0E
	1339	1629/1.3F	1914	2241/3.1E
9/13Sat	0012	0319/4.1E	0710	1009/3.4F
	1315	1548/2.9E	1913	2205/3.0F
9/14Sun	0059	0359/4.2E	0742	1038/3.5F
	1344	1624/3.5E	1952	2245/3.3F
9/20Sat		0246/3.4F	0619	0830/2.1E
	1120	1429/2.3F	1711	2049/4.6E
9/21Sun	0050	0353/3.1F	0731	0930/1.6E
	1222	1529/2.0F	1810	2150/4.3E
9/27Sat	0006	0313/4.1E	0651	0954/3.7F
	1250	1544/3.5E	1909	2208/3.5F
9/28Sun	0100	0358/3.9E	0732	1029/3.6F
	1324	1620/4.0E	1953	2253/3.7F



# EVENTUALLY, EVERYTHING WEARS OUT.

Production slots are still available for the Baja Ha-Ha, so contact a Quantum office ASAP!

**Quantum Pacific**  
sanfrancisco@quantumsails.com  
510.234.4334

**Quantum Seattle**  
206.634.0636



**Quantum San Diego**  
mreynolds@quantumsails.com  
619.226.2422

**Quantum Los Angeles**  
mtaylor@quantumsails.com  
310.518.2842

**Quantum Long Beach**  
562.799.7444

ANTICIPATE THE SHIFT

## WE'RE JUST NOT SURE HOW LONG EVENTUALLY IS.



How long will our cruising sails last? We still don't know. Quantum. The world's most durable cruising sails.





# SVENDSEN'S MARINE

## ACR Global Fix 406MHz Category 1, Class 1 EPIRB Internal GPS P/N 2742



- Faster acquisition time
- Led Status Lights
- Built in Strobe

LIST PRICE \$1450.00

SALE PRICE:

**\$829.00\***

\*Limited to Stock on hand

## Standard Horizon HX270S Hand held Submersible VHF Radio



- Huge Channel Display
- NOAA Weather Alert
- IPX7 Submersible
- Key Lock

LIST PRICE \$166.00

SALE PRICE:

**\$99.98**

## mcmurdo

### Fastfind Plus 406 Pib with built-in GPS



- Built-in GPS receiver
- Global alert to Cospas-Sarsat satellites
- 406MHz transmitter
- 121.5 MHz homing frequency
- Weighs just 11 oz.

LIST PRICE \$788.00

SALE PRICE:

**\$499.00\***

\*Limited to Stock on hand

PRICES VALID THROUGH SEPTEMBER 30, 2008

LOCATED IN THE ALAMEDA MARINA  
1851 Clement Avenue, Alameda  
CHANDLERY: 510.521.8454 • BOAT YARD: 510.522.2886

# LETTERS

## ↑↓ THE GREAT PACIFIC GARBAGE PATCH

I keep hearing about a 'garbage heap' out in the center of the Pacific Ocean, but don't remember *Latitude* ever writing about it. If it's as bad as people seem to say, wouldn't it be a navigational hazard to small boats such as 30-footers? Do the weather folks ever fill in mariners on how to best avoid such an area?

By the way, I was sad to note the passing of Mark Rudiger. I was inspired by the stories you did on him years ago when he modified his 29-ft wood boat to race in the Singlehanded TransPac and cruise to New Zealand.

Steve Cooper  
Rainbow, Rawson 30  
Emeryville

*Steve — If people use the word 'heap' — meaning "a mound or pile of a particular substance" — we'd say they were exaggerating about the amount of garbage in the Pacific. What most folks refer to are chunks of styrofoam, plastic bottles, big plastic bags, glass balls, fishing buoys, tangles of fishing line and other things that are such striking a contrast to the blue waters of the Pacific. It's theorized that there is a Pacific gyre from which most of this trash can't escape. Unfortunately, it's reputed to be the size of Texas, so it would be hard to sail around. In any event, if you have a decently built 30-footer, your boat shouldn't have any problem with the normal kind of garbage.*

*Abnormal garbage is another matter. For example, on the way back from the Singlehanded TransPac, singlehander Mark Deppe of the J/120 Alchera came across a full-size refrigerator, minus a door. Fortunately, he was in the calm waters of the Pacific High, because it conceivably could have caused damage to his boat if he'd been surfing down a wave. Other atypical garbage includes containers that have fallen off ships, barrels, half-sunk and off-station buoys, cylinders from Air Force rockets, eight-ft-tall Lego men, and god only knows what else. Perhaps the best place to find out about the possibilities is Beachcomber's Alert, an entertaining non-profit quarterly newsletter.*

*There are stretches of water besides the mid-Pacific where we think there are greater floating dangers. In the Pacific Northwest, for example, logs are a major hazard. Floating logs are bad enough, but the deadheads — logs which float vertically — can*

ALGALITA MARINE RESEARCH FOUNDATION



*This is an unusually large 'heap' of garbage in the Pacific, but even so it probably wouldn't hole a boat that hit it.*

*be particularly destructive to hulls. And as far as 100 miles off the coast of Colombia, there are dead cattle, trees, bushes, and other stuff that has travelled down the Rio Magdalena and 'streamed' far*

*into the Caribbean Sea. We remember surfing down waves on the way from Antigua to Panama, and having to change course rapidly to avoid small logs and other solid objects. Debris at sea is certainly a danger to think about — particularly on dark and windy nights when you're fatigued — but regular garbage shouldn't cause you grief.*



SUMMER OF

# RIGGING LOVE



Experience the **PASSION** of our Summer Rigging hot list:

**The Hot Kiss:** Free Installation on any new Harken or Schaffer furler, plus 25% off new lead back kit.

**Bear Hug:** 15% off new Harken electric winches with installation by Svendsen's.

**Roll in the Hay:** 25% off new standing rigging with installation by Svendsen's.

**Pole Dance:** 20% off all size Forespar line-control poles.

**Peek Under the Hood:** Free rig check with any Svendsen's haulout.



## SVENDSEN'S

Boat Works: 510.522.2886 or [www.svendsens.com](http://www.svendsens.com)

Chandlery: 510-521-8454 or [www.svendsensmarine.com](http://www.svendsensmarine.com)

**Congratulations to Shane Brooker!**

July ad contest winner for his guess of 927,463' of haulouts. Actual was 924,800'.



# BE A CRUISING SKIPPER!

## BASIC CRUISING SKIPPER'S PACKAGE

Learn to safely skipper boats up to 33' and qualify to charter modern cruising sailboats with full house amenities for a day, weekend or longer cruise.

Basic Keelboat Course = \$895

Basic Cruising Course = \$1095

Bay Cruising Workshop = \$75

**Total Value = \$2065**

Special Package Price:

**ONLY - \$1595!**

Sign up with a friend by September 30th and take off an additional \$100 each!\*

\*Course fee must be paid in full at sign up for discount to apply.

  
Club  
Nautique  
You're at the helm  
www.clubnautique.net

**LESSONS  
CHARTERS  
EVENTS**

Alameda 800-343-SAIL  
Sausalito 800-559-CLUB



# LETTERS

## ↑↓THERE'S ONLY ONE WAY UP MOUNT DIABLO

In last month's *Hiking the Channel Islands* article, mention was made of an easier hike up Santa Cruz's Mount Diablo from Coches Prietos. Unfortunately, that was an editing error, as there is no access to Mt. Diablo from Coches Prietos — without crossing the Central Valley, and that's off limits, even to Nature Conservancy permit holders. It may not seem like a big deal, but info about how to climb Mt. Diablo is impossible to come by, and I'd feel terrible if people found out the hard way that the article was wrong.

Chad Kominek ('03 Ha-Ha Vet)  
Bella Dama, Islander 36  
Ventura

Chad — We apologize for that editing error to your otherwise very informative article.

## ↑↓WHAT SAILBOATS SHOULD LOOK LIKE

Regarding your *Eye on the Bay* spread in the August issue, the Bristol you weren't able to identify is *Gypsy*, one of Cass' Marina's four nifty rental Bristol 27 daysailors in Sausalito. The other three are *Nomad*, *Hobo*, and *Vagabond*. These boats have been in service for many years. In fact, I remember renting one of them in the late '60s! Cass' has obviously done



LATITUDE / ROB

*The Bristol 27 'Gypsy' — what some folks think a "sailboat should look like."*

a great job maintaining the Bristol 27s, as they do all with all the boats in their fleet. The Bristol 27 is a sweet looking and sweet sailing design from the board of great naval architect Carl

Alberg. I remember seeing one on a mooring in the Benjamin River in Maine while on a charter, and she had that look that grabs one who appreciates what sailboats used to — and should — look like.

I left the Bay Area in '82, but return occasionally to visit. When I do, I usually try to rent a boat from Cass'. It's always a treat.

Larry Cooperman  
Columbia Challenger  
San Diego

## ↑↓MARK RUDIGER WAS A GREAT SAILOR AND HUMAN

I was shocked and saddened by the premature passing of Mark Rudiger, but I thought the *Latitude* piece by John Riise really captured the character of this great sailor and human being.

I first met Mark before the Singlehanded TransAtlantic Race (CSTAR) in '88, an event in which Mark sailed the Newick 40 trimaran *Ocean Surfer* to second place in Class 4. Mark had caught the keen eye of designer Dick Newick who, recognizing his great talent, chose Mark to skipper the trimaran. I sailed my Shuttleworth 42 trimaran *Damiana* in the same event. I kept a close rhumbline course, and was ahead of Mark most of the way across. But Mark reached up from the south in the last few hundred miles, crossed in front of me, and beat me to the finish.



# MOODY - NOT JUST FOR ROYALTY!



MOODY in North America . Ph: 1-410-626-1493 . [dwalsh@moodyboats.com](mailto:dwalsh@moodyboats.com)

Visit our website for the dealer nearest you.

 **Moody**<sup>®</sup>

[www.moodyboats.com](http://www.moodyboats.com)

45 DS<sup>e</sup>



passionate about sailing

## SAILING VACATIONS

This  
Fall Save  
up to **25%**  
in the Caribbean  
Call for details



## Live your passion with Sunsail

If you love sailing and have a passion for new and exciting experiences, then Sunsail is your perfect choice. This year we celebrate 35 years of delivering great value sailing vacations with a cutting-edge fleet, in the world's best cruising grounds. With a professional yet personal touch, our friendly staff is always ready to advise you, with insider tips and ideas to turn your vacation into the memory of a lifetime.

Trust your vacation to Sunsail –  
The company that loves sailing as much as you do...

Call 800 734 8682  
or visit [www.sunsail.com](http://www.sunsail.com)



 **Sunsail**  
SAILING VACATIONS

Caribbean • Mediterranean • South East Asia

## LETTERS

It was obvious from way back then that Mark was very sharp, a great sailor, and an all around great guy with a wry wit. *Ocean Surfer* was an overweight racer, and not as fast as advertised, but Mark got the most out of her. I remember him reporting that a leaking hatch had resulted in the trimaran becoming *Ocean Submerger*.

After building the high-powered Shuttleworth 30 trimaran *Nai'a*, I asked Mark to join our crew. He didn't hesitate, as he loved fast boats of any kind. He immediately fell in love with her. I warned him that the tri was overpowered and hadn't been fully shaken down, so I wanted to know if he was ready for it. "I was born ready," he replied, and he wasn't bragging.

On our first race with *Nai'a*, the Windjammers in '92, we chased the Antrim 40 tri *Aotea* down the coast off Davenport. Mark was driving hard with full main and spinnaker in strong afternoon winds and big seas, when the rudder ventilated. *Nai'a* rounded up into the wind and capsized backwards. Mark came up apologizing profusely, but it hadn't been his fault. With a 50-ft wing mast and very fine bow, *Nai'a's* stern would often lift, causing the rudder to ventilate. But Mark, a great competitor, was always going for the win.

Mark went out with us on the salvage boat, and helped us bring *Nai'a* back in. I have a picture of him standing on the flipped trimaran hooking up the tow line. We ended up lengthening *Nai'a* to 36 feet and fitting her with three rudders. Mark later helped sail her to victory in a Silver Eagle Race and a Doublehanded Lightship Race.

A few years ago I called Mark to ask him to do the weather routing for me on my next solo record attempt to



LATITUDE ARCHIVES

**Mark Rudiger, a great competitor  
and a wonderful human being.**

Japan with my monohull *Thursday's Child*. Mark said sure, if he could fit it into his busy schedule. I ended up not going. I sold *Thursday's Child* 2.5 years ago, and bought a Grainger 43 trimaran I've renamed *Dolphin Spirit*. I'm getting her ready for another go at the solo record to Japan next year, and had planned to have Mark do the weather routing. He would have loved the lines, the power, and the speed of *Dolphin Spirit*. My sail to Japan will be dedicated to ending the dolphin slaughter in that country, but I also will sail with fond memories of Mark, and try to summon up some of his skill and determination when I need it.

Michael Reppy  
Dolphin Spirit Project  
Earth Island Institute

Readers — We were friends with Mark Rudiger when he was a 'nobody' installing various boat systems in Sausalito in the '70s. Over the years we raced with him and against him, saw him at any number of TransPac finishes, and even cast off the lines of his Carlsen 29 when he and his then-wife Kay left the *Ala Wai* for New Zealand. We last saw Mark at last year's St. Francis Big Boat Series, as he'd just flown in from the Maxi World Cup in Sardinia. He hadn't changed a bit. For despite having become well-established as one of the most respected sailor/navigators in the world, he was as friendly and modest as ever. Mark was a special sailor and an exemplary person, and we'll miss him.





# VALLEJO MARINA

Gateway To The  
Bay & Delta



Join us!  
We love making new friends  
and spoiling them!



See us at the  
No. California  
Fall Boat Show  
Jack London Square  
Oakland  
Sept. 6-14



- Competitive Rates!
- Great Restrooms with Showers
- Ample Guest Dock
- Full Service Boat Yard and Chandlery
- FREE Pump Out Stations
- Fuel Dock
- 2 Restaurants for Breakfast, Lunch, Cocktails and Dinner
- Covered and Open Berths
- Launch Ramp

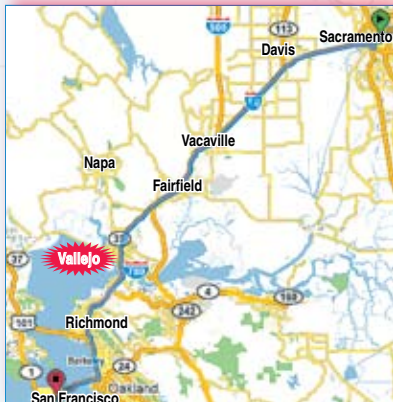

- One hour from Sacramento
- Only Three hours from Reno
- Easy access to San Francisco Bay and the Delta

**(707)  
648-4370**

Fax 707-648-4660

42 Harbor Way • Vallejo, CA 94590 • [www.ci.vallejo.ca.us](http://www.ci.vallejo.ca.us)





Style. Fit. Performance.



Billy Black Photo



See our website [www.harken.com](http://www.harken.com) for our complete line of sailing gear.



1251 E. Wisconsin Ave., Pewaukee, WI 53072  
 Tel: 262-691-3320; Fax: 262-691-3008 Email: [harken@harken.com](mailto:harken@harken.com)  
 Web: [www.harkensailinggear.com](http://www.harkensailinggear.com)

## LETTERS

### ↑↓ I'M CONFUSED BY THE C.O.B. SET UP

Regarding the crew overboard training piece in the August *Sightings*, it contains the following quote: "There's no way my wife could get me onboard with a 3:1 tackle". The man quoted was speaking about his Lifesling, so I guess that I'm a little confused by that product.

I participated in the *Latitude* 'sponsored' Crew Overboard Program (COB) a few years ago, and I remember a seminar at which the speaker said that the block and tackle — included



The block and tackle is just out of sight in this photo of the Swift Recovery system in action.

in the Lifesling — was to be used to connect the main halyard to the person in the water, but not to actually lift the person out of the water. Main halyards are typically not long enough for the shackle

to connect directly to the person in the water. So, you use the tackle to connect the halyard to the person, and take up slack with the tackle. Then you winch-up using the main halyard. Indeed, most tackles I've seen are made using small line, which would cut a person's hands if they tried to lift a person with it.

Incidentally, I don't see any tackle in the photograph. Am I right that Mary SwiftSwan's rig doesn't use one? Is that line an integral part of her rig, or is that line the main halyard? I'm guessing it's not the main halyard, considering there are at least two 'figure eight' knots in the line, which would make it hard to be used as a halyard.

P.S. I've loved *Latitude* since I first took up sailing back in 1987.

(Mr.) Leslie D. Waters  
 San Jose

Leslie — Mary SwiftSwan responds: "Actually, more than one boat under 40 feet in our group discovered that a higher-ratio block and tackle worked much better for them. Remember that hoisting tackle are optional for LifeSlings, and must be purchased separately.

"The pre-packaged 3:1 line is indeed small. Under pressure, the line hurts the hands and is hard to pull. Gerhart's 30-ft boat has small winches, which made it hard for his wife to pull a person of his size out of the water. The 5:1 or 6:1 tackle worked much better with thicker line. The larger boats didn't have a problem with the lower-ratio hoisting tackle as the larger winches accommodated more wraps.

"Here's how to use a block and tackle with a LifeSling:

- 1) Heave to or douse sails to free the main halyard
- 2) Connect the top of the tackle to the main halyard
- 3) Raise and secure the halyard 10-15 feet off the deck
- 4) Lead the line that exits from the top of the tackle through a fairlead to a multi-speed winch in the cockpit
- 5) Clip the other end to the LifeSling
- 6) Grind the winch to bring the person up and out of the water, and clear of the lifelines

"The Swift Recovery device you noticed has a 50-ft 'soft touch' floating line. There are a series of eight knots in the line near the floats which are meant to be used as handholds.



W

L

X

O

O



**YOUR OLYMPIC DREAMS. OUR SAILS.**

Doyle Sailmakers helping to make your dreams a reality. Contact your local Doyle loft or visit [doylesails.com](http://doylesails.com).

**Doyle San Francisco**

Bill Colombo & Rusty Canada  
2035 Clement Avenue  
Alameda, CA 94501

510-523-9411

[sanfrancisco@doylesails.com](mailto:sanfrancisco@doylesails.com)

[doylesails.com](http://doylesails.com)

800-94-DOYLE

BETTER ENGINEERED SAILS

# Clean Boat Bottoms Today... Cleaner Bays and Waters Tomorrow.



Help keep our bays and waters clean for the boaters of tomorrow.

Introducing Sea Hawk's  
New Copper-Free  
"GREEN" Antifouling:  
Mission Bay



Available at your local boatyard or contact us:



Family Owned &  
Operated since 1978

NEW NAUTICAL COATINGS, INC.

800.528.0997 U.S.A. Only • 727.523.8053 International  
contactus@seahawkpaints.com • www.SeaHawkPaints.com

## LETTERS

*There is indeed a hoisting tackle clipped into one of the knots, but it is optional because the line provides extension and can be connected directly to the halyard if a two-speed or electric halyard winch is available.*

*"I hope that answers your questions."*

### ↑↓WHAT'S THE DEADLINE TO SIGN UP AS HA-HA CREW?

My only question about the Ha-Ha is the deadline for signing up for the '08 Ha-Ha Crew List as crew.

David Stephens  
San Diego

*David — You can sign up for the Ha-Ha Crew List right now by following the instructions and filling out the forms found at [www.latitude38.com/crewlist/Crew.html](http://www.latitude38.com/crewlist/Crew.html). The other big opportunity is during the Northern California Ha-Ha Kickoff Party at the Encinal YC in Alameda on September 10. The last chance is showing up at the Ha-Ha Kick-off and Costume Party at the West Marine Superstore on October 26 in San Diego, which is the day before the start of the rally. The latter is admittedly pretty late in the game to sign on, but almost every year four or five people have done it and lived to tell about it.*



LATITUDE / RICHARD

*If you sign up for the Mexico-Only Crew List, you could be part of the fun in the 'Fabulous Fifteen' Baja Ha-Ha.*

### ↑↓WE SAW TWO MIRAGES ON ONE DAYSAIL

I had the opportunity to go for an afternoon sail on June 20 with Bob and Sandy Goldberg aboard their Sausalito-based Catalina 380 *Barca Vela*. It was dead calm and hot when we left the berth at noon. We motored out the Gate into a decent flood on mostly glassy waters. After we were abeam of Baker Beach — we could see that the beach was packed, as it was sweltering, even in the City — an 8- to 12-knot westerly breeze filled in, so we spent several hours lazily tacking back and forth into the flood, dodging lots of freighter traffic.

Visibility out to sea was quite good, but a little hazy, as the heat waves coming off the Pacific made things shimmer a bit. We could see the freighters turning north and south as they passed



BILL NORK

*the Lightbucket. Then something odd happened. We had two good-sized ships in sight offshore near each other in the main channel, when the shape of another ship appeared from the from the north. We saw the dark outline of the new ship that was easily twice as long as*

*the other ships. And it appeared to be at least three times taller than the others! There was no way we could imagine a freighter that large.*

*As the gigantic ship came closer to us, it shrank in size until it was eventually the same size as the others. We could only guess that this optical illusion was some type of mirage caused by the heat of the warm air passing over the colder air on the surface of the sea.*





# MODERN SAILING SCHOOL & CLUB

Sausalito, CA [www.ModernSailing.com](http://www.ModernSailing.com) 800-995-1668

Stay Active on the Bay.  
Join the Club!

Only \$35 a month!

### Upcoming Events

- ▲ Sept. 13 - Full Moon Sail
- ▲ Sept. 13 - Full Moon Hike
- ▲ Sept. 23 - KQED's Screening of QUEST, The Physics of Sailing @GGYC, 6:30pm
- ▲ Sept. 28 - Sail Fest
- ▲ Weekly Club Sails & BBQs!

### Adventure Sailing with John Connolly



Obtain advanced ASA certifications world wide!

#### Caribbean / Trinidad

St. Lucia - Antigua - Trinidad - St. Lucia  
December 2008 - January 2009

ASA 106, 107, 108

\$2175 - \$4450

#### Canary Islands / Spain

Canary Islands - Gibraltar - Balearic Islands  
March - April 2009

ASA 106, 107, 108

\$2175 - \$4450

Call us for details  
(415) 331-8250

### California Coast

#### Advanced Coastal Cruising

Explore the California Coast in this 4 day adventure. You will gain confidence in navigation, anchoring, boat systems, radar use, and cruising the California Coast.

September 11 - 14

Includes ASA 106. Cost is \$1145.

#### Heavy Weather Offshore Course

Gain valuable confidence and advanced sailing skills in a variety of conditions. Join John Connolly on our well equipped Islander 53' for a 7 day trip to Monterey and back.

October 20 - 26

Includes ASA 105, 106. Cost is \$1675.

the First Annual

# Sail Fest

Sunday, September 28th  
11am to 5pm

at Modern Sailing School & Club in Sausalito

Have you been thinking about sailing?



▲ Free Sailboat Rides (with RSVP)

▲ LIVE Music and Food

▲ Guest Speakers

▲ Boat Show

Everybody is welcome - Attendance is FREE!

Call 415-331-8250 now to get on board.

### Sponsors and Featured Yachts



Golden Gate Yacht Club



Hanse Yachts, Northern California

PREPARE TO TAKE THE HELM

# SHAFT SHARK

**The best rope,  
line and debris  
cutter there is!**

Two piece unit

For both  
power and sail



AB Marine, Inc.

747 Aquidneck Ave.  
Middletown, RI 02842

401-847-7960

Fax: 401-849-0631

sales@ab-marine.com

www.ab-marine.com



# Gori<sup>®</sup> propeller



3-Blade



2-Blade



Racing

AB Marine, Inc.  
747 Aquidneck Avenue  
Middletown, RI 02842

Phone: 401 847 7960

Fax: 401 849 0631

sales@ab-marine.com  
www.ab-marine.com

## LETTERS

By then it was about 3 p.m., and a nice 20-knot westerly had built, whisking us back through the Gate on what was left of the weakening flood. The buildings in the Financial District were shimmering eerily in the heated waves of air passing over unusually warm San Francisco.

Then, to our surprise, we saw another mirage which made it look like the main suspension cables of the Bay Bridge were bending and distorting crazily — as if a major seismic event was taking place. So I took the accompanying photo.

On the way back to Sausalito, it looked like the distant, normally low-lying Richmond shoreline, was four or five four stories high.

I've been sailing the Bay for almost 40 years and have never seen anything like this. Have you heard of any similar reports from that Friday?

Bill Nork  
Emeryville

*Bill — We haven't heard of any other such reports, but we're not surprised, as such mirages are very common on San Francisco Bay. We've seen so many over the years we don't pay them any mind. According to scientists, mirages are naturally-occurring optical phenomena in which refracted or bent — because of the heat — light rays produce displaced images of distant objects.*

### ↑↓WE MAXED OUT AT 24 KNOTS

You asked to hear from sailors about their top speeds with monohulls. While delivering the Wylie 37 *Absolute 88* from San Francisco to Santa Cruz on a very windy day a few years ago, the speedo kept showing ever higher numbers. We finally saw a top speed of 19 knots. But later, when checking the 'maximum speed' feature on the GPS, it showed 24 knots.

Keith MacBeth  
Planet Earth

### ↑↓THAT'S NOTHIN' — WE HIT 25.3

My '84 Catalina 38 *Barking Spider 2*, hit a top speed of 17.1 knots while surfing big swells on the way from the San Francisco Buoy to the Golden Gate. We were carrying a full main and 135% genoa in winds to 25 knots and 15-ft swells. I think the big swells gave us the lift, as we repeatedly surfed into the teens going down the faces.

Later, aboard my '87 MacGregor 65 *Barking Spider 3*, we reached the low 20s anytime we sailed downwind in 30 knots of breeze. Our top speed was 25.3 knots, which we hit on three different occasions. The most memorable of the three was the time we were surfing north from Catalina to San Francisco. We'd caught the front end of a February southerly and saw steady winds of 30-35 knots, with a top gust of 43 knots. We were flying a double-reefed main and a 100% jib.

David Kory  
Pt. Richmond / Buenos Aires

*David — Over 25 knots while sailing up the coast of California — that could be a record.*

### ↑↓I WAS SUNNING MY BUNS WHILE WE DID 10.32

Our *Valkyrie* is a hard chine Roberts 44 steel boat that we spent too many years building. In fact, if *Latitude* is ever in the mood to do another article on people building their own boats, we can offer some unique insights. Nonetheless, we love our boat dearly, and participants in the 'Lucky 13' Ha-Ha may remember her. *Valkyrie* is very comfortable and has a sea-kindly motion — mostly due to her slack bilges and 25-



# BOAT LOANS



*from*  
Trident Funding

*"a fresh approach from  
people you can trust"*

**See us at the  
Northern California Boat Show  
Jack London Square • September 6-14**

*In Northern California call*  
**JOAN BURLEIGH**  
**(800) 690-7770**

# Serious Sailors

**isotherm**  
Marine Refrigeration

**isotemp**  
Marine Stainless Steel Water Heaters



## The Winning Team: Isotherm, Isotemp and You!

- ▶ 45 Years of Marine Heritage
- ▶ Refrigerators and freezers up to 9 cubic feet
- ▶ Build-in units up to 17 cubic feet
- ▶ Water heaters up to 20 gallons
- ▶ Complete range of marine products

Blue water sailors know how important dependable refrigeration and hot water are to a successful cruise. Built of the highest quality materials, Isotherm and Isotemp products are designed to last and use the absolute minimum of battery power.

Refrigeration systems including holding plate systems, water cooled, air cooled, SP thru-hull, and ASU energy management systems. Top loading refrigerators, cabinet refrigerators, drawer refrigerators stainless steel doors, glass front doors. Stainless steel water heaters

**indel**  
**Webasto**  
Marine USA

1-800-422-9711

[www.IndelWebastoMarineUSA.com](http://www.IndelWebastoMarineUSA.com)

Isotherm and Isotemp are distributed on the West Coast by:

Fisheries Marine Supply - Seattle 800-426-6930  
Aegis/MMI - Newport Beach 800-747-3014

Service, Installation and Sales:

Miller and Miller Boatyard - Seattle 206-285-5958  
Svendsen's Chandlery - Alameda 510-521-8454  
Southern Cal Marine - San Diego 888-657-1606

## LETTERS

ton displacement when in fully loaded cruising mode. While she may never plane, she doesn't pound either.

Enough of that. Let's talk about top speeds on our true cruising boat. It was blowing a steady 25 with gusts to 30 in the Slot one July a few years back. We were beam reaching in four-foot chop while carrying just a double-reefed main and staysail, and were doing a steady 8.5 knots. When hit by gusts, *Valkyrie* would get into the mid-9s, and for a brief moment hit 9.8 knots. The odd thing that I remember is that we didn't really speed up when we got hit by a gust, it was only after the gust dissipated that we accelerated. It was as though *Valkyrie* absorbed the energy, but took just a little time to translate it into boatspeed.

*Valkyrie's* all-time speed record was set one day in late September while on our way to the start of the '06 Ha-Ha. We left Santa Cruz Island early in the day on our way to Pt. Mugu. We started in light air, but the wind continued to build. Soon we were on a very broad reach with the full main all the way out and prevented, the 110% jib poled out, and the staysail pulling like a mule. While snoozing on the foredeck and enjoying the warmth of the afternoon sun on my buns, I woke up with a start because of the loud roaring of the bow wave. I realized that it was really windy and that we had too much sail up. I asked Rosey about our boat speed, and with great delight she told me that we were doing 9.5 to 10 knots. When I asked her about the windspeed, she said it was 30-32 apparent — which meant the true wind was in the 40s. Even though our autopilot, One-Eyed Willy, was having no problem steering, it just seemed like we were on the verge of spinning out. After we reduced sail, the knotmeter registered our top speed — 10.32 knots!

If you ever want to do an article on ways of setting sails on a cruising boat so that there is no need for a spinnaker, I can tell you about some old tricks that modern racers never think of.

David & Rosey Eberhard  
*Valkyrie*, Roberts 44

In San Diego, prepping for the next voyage

*David and Rosey — Good stuff. By the way, we corrected a misspelling in your letter; one of the most humorous we've come across. You wrote ". . . on our way to Pt. Magoo." But rest assured that we're laughing with you, not at you, for over the years we've made every blunder that could be committed with a keyboard.*

### ↑↓SURFIN' SEA FOX

I'm proud to have achieved some surprising speeds with our '92 Beneteau 38 *Sea Fox*. It happened during a delivery down to Southern California for the start of the '06 Ha-Ha. With the wind blowing a steady 25 knots, and the boat carrying a full main and a poled-out 120% genoa, we surfed down 8-ft seas. Our GPS recorded speeds between 10 and 14.4 knots. It was better than any roller coaster ride that I've been on, and the best part is that it lasted for hours. If anyone wants to see what it was like, they can check out <http://video.yahoo.com/watch/55509/1049330>.

Fredrik Hakanson, Part Owner  
*Sea Fox*, Beneteau Moorings 38  
San Francisco

### ↑↓THE BEST SPINNAKER RUN EVER

The Catalina 27 is said to have a hull speed of about 6.2 knots. In a cruise from Half Moon Bay to Monterey in September of '95, my *Enigma II*, a then-21-year-old boat, averaged



# THE FINEST SAILS BEGIN WITH THE BEST SAILCLOTH

Our patented woven Vectran® sailcloth performs like the laminates with the durability of Dacron®, especially in roller furling applications. In fact, Vectran® is lighter, lower stretch, and retains its shape over a longer life than any sailcloth we've ever offered to cruising sailors. That's because Hood Vectran® is woven, not laminated to Mylar® film. And you can be sure that each sail we roll out is built by hand, with the same care and craftsmanship that has been the Hood hallmark for 50 years. To discuss your sailcloth needs – whether our state-of-the-art Vectran® or our soft, tight-weave Dacron® – give us a call today.

**HOOD Sails & Service**

**HOOD New Sails**

**HOOD Sail Repairs**

**HOOD Furling Conversions**

**HOOD Pickup & Delivery**

**Outbound Yachts  
New Outbound 52  
with Hood Vektron  
Vertical Full Batten  
In-Mast Furling  
Mainsail and 135%  
Vektron Genoa**

**PHOTO COURTESY  
SWIFTSURE YACHTS**



**SAILMAKERS**

**HOOD SAILMAKERS 466 Coloma Street, Sausalito, CA 94965**

**Call Robin Sodaro (800) 883-7245 (415) 332-4104 Fax (415) 332-0943 hoodsails@aol.com**

**Visit our website for Special Online Discount Pricing... [www.hoodsailmakers.com](http://www.hoodsailmakers.com)**

95% First Time Pass Rate  
100% Satisfied Graduates



U.S. Coast Guard approved  
courses and testing.  
Approved for Veterans.

# Captain's License

6 Pack/100 TON  
Towing & Sailing

## THE NEXT LEVEL OF EDUCATION

Advanced Training more than  
30 College Accredited and  
U.S. Coast Guard approved courses.

Boat Owners • Cruisers • Crew  
Take the same Captains course offered to  
professional mariners. You'll get advanced  
training in safety, navigation, radar, radio and  
rules of the road. The training everyone needs.

**RADAR • RADIO • NAVIGATION • SAFETY**

# MARITIME INSTITUTE

Classes offered in the Bay Area, Lake Tahoe,  
Arizona, and Southern California.

**CALL TOLL FREE 888-262-8020**

OR visit our website for more information.

[www.MaritimeInstitute.com](http://www.MaritimeInstitute.com)

Also offering the full list of  
International Yachtmaster® Training Courses

## LETTERS

7.1 knots on the 36-mile stretch from Ano Nuevo to Monterey, never dropping below 7 knots. There were several periods when the Loran and GPS indicated over 9 knots, and the top speed achieved was 9.2 knots while sliding down a roller on Monterey Bay. And, mind you, we had five sailors aboard, none of us ultralights.

We were sailing with the spinnaker up, of course, but had no round-ups or other problems, even when the tiller pilot was driving. I would later do two Ha-Ha's, and some of the rest of the crew would later circumnavigate the South Pacific. But we still agree that was the best spinnaker run we've ever had!

Peter Hine  
*Enigma II*, Catalina 27  
Stockton

*Peter — It must have been a great sail for you to remember it so fondly 13 years later. We wonder if anyone on the East Coast has had as memorable a sail.*

### ↑↓CATALINA 42 TOP SPEEDS

*Wind Dancer*, a Catalina 42 owned by Dr. P.K. Edwards out of Ventura, hit 16.8 knots plowing down a big wave while doing a heavy air Coastal Cup a few years ago. We got our own Catalina 42 up to 10.9 knots coming back from San Clemente Island a number of years ago. That was pretty exciting, so I can't imagine what a 16.8 would be like.

Garry Willis  
*Breezn*, Catalina 42  
Marina del Rey

### ↑↓A WILD AND WONDERFUL RIDE

On the trip home to Newport, Rhode Island, from Bermuda aboard my '78 Pearson 35, we were routinely pegging the knotmeter at 12 knots. The apparent wind was blowing 35 to 40 knots, and we hit the top speed while surfing down waves in the Gulf Stream. Later, when things had calmed down a bit, we looked up the 'maximum speed' on the GPS, and found that we'd hit 16.9 knots! Since we were travelling across the Gulf Stream rather than with it, that's probably pretty close to our through-the-water speed as opposed to current-assisted speed-over-the-ground. It was a wild and wonderful ride!

Dave Thornton  
*Scheherazade*, Pearson 35  
Newport, RI

### ↑↓MORE SPEEDY CATALINAS

In the fall of '04, while racing from Annapolis to Oxford, Maryland, during the tail end of a hurricane, my Catalina 27 *Four Little Ducks* hit a top speed of 14.4 knots. This occurred while surfing downwind in 45 knots of breeze with a reefed main and a poled out #2 genny.

Tom Walsh  
*Four Little Ducks*, Catalina 27  
Annapolis, MD

### ↑↓30 KNOTS SEEMED BENIGN

The strong winds you reported that a group of cruisers had seen last month on the way from French Polynesia to Suvarrow reminded me that you were asking what kind of peak speeds cruising boats have hit. Back in '92, we sailed the Santa Cruz 40 *Defiance* from Santa Cruz to New Zealand. On the way from Bora Bora to Penrhyn in the Cook Islands we had southeast winds of 35 to 45 knots for about 12 hours. We hand steered most of the day under single-reefed main and no jib, but I remember we still hit a high of 18.5 knots.



# 36th Annual NORTHERN CALIFORNIA FALL BOAT SHOW

*Jack London Square  
Port of Oakland*

**September 6-14**

**Weekdays: Noon-6**

**Weekends: 10-6**

**Adults: \$10**

**Kids under 15 FREE!**

**SAIL & POWER!**



**NEW & PRE-OWNED BOATS**



**LONG RANGE CRUISERS**

**Last  
Big Show  
of the Year!**

**Bring this coupon for**

**\$2.00 OFF** adult admission

**NORTHERN CALIFORNIA FALL BOAT SHOW '08**

*Jack London Square Port of Oakland*

**September 6-14, 2008** L-38

[www.ncma.com](http://www.ncma.com) 1(800) 698-5777

# LOCH LOMOND MARINA



**Completely Rebuilt Marina**  
**Gas & Diesel Fuel Dock**  
**Free Pump Out Station**  
**Modern Launch Ramp**  
**Guest Slips Available**  
**Marine Mechanical Boat Repair**  
**Arena Marine Supply Store**  
**Loch Lomond Market**



**110 Loch Lomond Drive**  
**San Rafael, CA 94901**  
**Phone: (415) 454-7228**  
**Fax: (415) 454-6154**  
**www.lochlomondmarina.com**  
**Harbor Master – Pat Lopez**  
**pat@lochlomondmarina.com**

## LETTERS

But that was far from the end of it. Late in the day, we double-reefed the main and let the autopilot steer. The result was an accidental jibe, during which time the mainsheet caught on the steering pedestal and ripped it right off the cockpit sole! Fortunately, the autopilot was connected directly to the rudder post, so it kept steering a good course while the wheel and pedestal flopped around in the cockpit, connected only by the steering cables. It required several hours of work to reinstall the original tiller and patch up the hole. By that time the wind had dropped down to about 30 knots, which seemed benign by comparison.

Don & Katie Radcliffe  
Santa Cruz

*Readers — Since something like 80 boats sailed to Hawaii last month in the Pacific Cup and Singlehanded TransPac, we're still open to reports on top speeds for monohulls.*

### ↑↓BRAVO FROM AN ENVIRONMENTALIST

Thanks so much for the *10 Ways to Reduce Your Carbon Footprint* article in the July *Latitude*. As an environmentalist, it's everything I could have hoped for from a sailing magazine, and then some — you even mentioned buying locally grown food. Once again, *Latitude* shows that it's head and shoulders above the rest!

Jeff Hoffman  
San Francisco

*Jeff — Thanks for the kind words. God knows we've got a long way to go, but we're finding that it's not that difficult — and often times a lot of fun — to use less energy and fewer resources. LED boat lights, here we come!*

*It's nice to learn that we Americans have used less fuel every month for the last six months, and that the Chinese have cut back, too, as reduced consumption has been a major factor in the price of oil having plummeted 34% from its all time high. If we Americans, still the biggest per capita users of energy in the world, could cut our usage by another 10%, the downward pressure on oil prices would be tremendous and the supplies would last that much longer. Some people have mocked the little things — such as correct tire pressure — that can increase fuel efficiency. Idiots. Sure, that's not going to solve the long term problem, but every little bit helps. In fact, it reminds us of the TransPac a few years ago when sailing great Stan Honey and his Cal 40 Illusion crushed the rest of that one design class. He and his crew did it not by having a different boat, but by just doing scores of little things a little better. No matter if you're sailing or trying to conserve fuel to exert a downward push on prices, the little things do add up. Having said all that, we still fully support the development of nukes and clean coal as well as wind and solar. We're going to need them all.*

### ↑↓ANOTHER ECO-FRIENDLY BOAT TIP

I enjoyed reading your article on eco-friendly boating. I know that you only have so much editorial space, but I was surprised that no mention was made of the simple and solar-powered SunShowers. I have used them for decades, both up in the Delta and while at anchor after a lively sail. They are inexpensive, simple, and refreshing.

P.S. Thanks for all the years of great reading!

John Chille  
Love In Vane, Golden Gate 30  
Alameda

*John — Thanks for the kind words and the SunShower*



# ANDERSON'S BOAT YARD

*Bring on the NACs!*

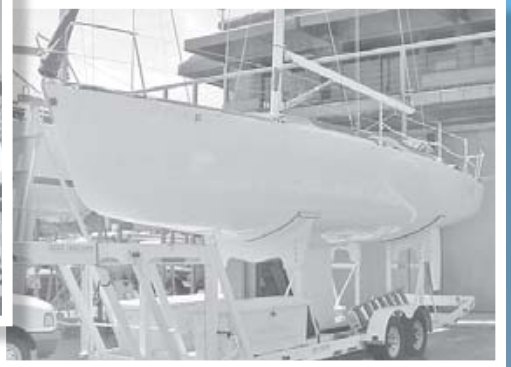

*Current Obsession,  
Distant Passion,  
Convexity,  
Masquerade and  
Streaker get ready  
for the 2008 J/105  
North American  
Championships.*



***The #1 Boat Yard on the Bay***

*All of us at Anderson's  
would like to thank  
all our customers  
for choosing the  
#1 boatyard  
on the Bay.*

***Call now to reserve space for:***

- Sprayed racing bottoms
- Custom topside paint jobs
- Complete rigging shop
- Custom metal fabrication
- Electrical installation & repairs
- Engine service and repower

***Come see us  
for your  
boating needs!***

**400 HARBOR DRIVE • SAUSALITO, CA 94965  
(415) 332-5432 • (800) 310-5432**

**Fax: (415) 332-8136**

**andersonsboat@pacbell.net  
www.andersonsboatyard.net**

** Interlux**  
yachtpaint.com

# North times seven.

When performance counts the choice is clear.  
Call your nearest North Sails representative.

## Sausalito

415-339-3000

## San Rafael-Sail Care

415-453-2142

## Channel Islands

805-984-8100

## Marina Del Rey

310-827-8888

## Long Beach

562-795-5488

## Costa Mesa-Sail Care

949-645-4660

## San Diego

619-224-2424



[www.northsails.com](http://www.northsails.com)

## LETTERS

reminder. Probably 95% of all showers on Profligate have been taken using a SunShower. We're big on simplicity, and a



**Solar showers are another great way to save water and energy.**

SunShower is about as simple as you can get. We usually get two to three showers out of a five gallon Sun Shower. We're not sure how much water is used in a typical onboard pressure water shower, but a typical home shower uses 12.5 gallons of water — while a typical bath uses an astonishing 35 gallons.

We realize that most people — particularly women — enjoy luxury more than we do, so we're not advocating Sun Showers for everyone. But we're fine with them in most situations, particularly when cruising. And when you finally get to a land shower, it truly seems like extreme luxury.

The only proviso about Sun Showers is to use them before it gets too late in the day, or they'll be more invigorating than you'd like.

### ↑↓ THE SWIMMING WAS GREAT IN CLIPPER COVE

With regard to the recent letters about Clipper Cove, I definitely agree that there's plenty of space for folks to anchor. The 'unattended' boat issue is more about aesthetics than space



COURTESY LIBERTY

**Russ Cooper and friends had a great time in and out of the water in Clipper Cove.**

— at this point anyway. I was anchored there this past weekend, and counted about 15 boats that appeared to be unattended. Three or so were in good repair, a half dozen looked as though nobody had

been aboard in a long time, and another half a dozen looked completely abandoned and in bad shape. But they certainly didn't slow us down from having a great time. It was Delta-warm on Saturday — even the swimming was great.

Russ Cooper  
Liberty, C&C 37  
San Francisco

*Readers — This letter first appeared in 'Lectronic, and we're running it to make sense of the following letter.*

### ↑↓ HOPE THEY DIDN'T SWALLOW ANY WATER

Regarding Russ Cooper's comments about Clipper Cove in the August 5 'Lectronic, in which he observed, "The 'unattended' boat issue is more about aesthetics than space — at this point anyway." I agree that aesthetics are involved, but perhaps not the same aesthetics as he thinks.

Cooper noted that there is still plenty of room to anchor among the semi-permanent derelict fleet anchored in Clipper Cove, several of which have liveaboard owners. That may very well be so, and I didn't necessarily disagree — until he concluded with the comment, "It was Delta-warm on Saturday



# Cheers to the Big Boats!

**We wish our best to the participants in the 2008 Big Boat Series. Competing in the event is an honor in itself. For the**



**rest of us, don't miss the racing on Cityfront, Sept. 11-14. As a spectator sport, it's hard to beat.**

**Whether you're competing with the Big Boats, or in club beercan races, we can help make your boat sail to its potential.**



## Lift capacity 35 tons

Sprayed Racing Bottoms

Full Painting Service

Fiberglass & Gelcoat Repairs

Rigging Repairs & Installation

Electrical Repairs & Installation

Engine Service & Repowering

Propeller Installation & Tuning

Wood Hull Repairs & Caulking

Teak & Non-Skid Deck Repairs

**Call us to schedule your boat!**

**Chandlery &  
Fuel Dock  
Open 7 Days**

Mon – Fri  
8 am to 5 pm  
Sat & Sun  
9 am to 5 pm



*We feature*  
**Seahawk**  
*Antifouling  
Bottom Paint*



**A high-performing,  
environmentally friendly  
bottom paint!**

(see details on our website)

**In Berkeley Marina • 510-843-8195 • [www.berkeleymarine.com](http://www.berkeleymarine.com)**

# Sailing Away?

We build custom  
sails to suit your  
needs, your boat,  
your plans.

Call now for  
delivery in time for  
the Baja Ha-Ha



Keep cruising with  
**HOGIN SAILS**



- New racing or cruising sails
- Roller furling conversions
- All sails manufactured at our Alameda loft
- Repair and service

In the Alameda Marina at  
1801-D Clement Ave., Alameda, CA 94501

**510.523.4388**

Mon-Fri 8:30am to 5pm  
Saturday by appointment only

sales@hoginsails.com  
service@hoginsails.com  
www.hoginsails.com

## LETTERS

— to the point that the swimming was great!" Uh oh!

In the photo he provided, it shows smiling people, holding beverage containers aloft, and swimming in the cove astern of rafted up boats. I'm guessing these people in the water were only smiling because it hadn't occurred to any of them that the liveaboard owners of the grungy, off-the-grid boats aren't very likely to have visited a pump-out station. Based on a look at the anchor rhodes of those boats, my hunch is that they haven't been moved in quite some time. I wonder what they do with their waste products?

And speaking of Delta-warm, I was anchored in the Bedroom One anchorage on Potato Slough in the Delta one recent Saturday, where at sundown everyone was treated to a bagpipe performance by Harley Gee of the Catalina 42 *The Taproom*. It has become a summer weekend evening tradition for Harley to play two or three songs from his cabintop just as the sun drops to the horizon. His wife, Anna, who later admitted to having had a little wine, could be seen through binoculars dancing a jig on the foredeck during the mini-concert. Harley is pretty good, too, although he modestly noted that playing bagpipes usually means no one notices when he misses a note or two. But the haunting sound of *Amazing Grace* carrying across a quiet anchorage is charming beyond description.

Rod Williams  
Azure, Catalina 42  
Alameda

*Rod — It is, of course, against the law and common courtesy to poop in either Clipper Cove or the Delta. Nonetheless, given the much greater number of boats, fishermen, little kids, and hikers, we wonder if the fecal coliform count might be higher in Bedroom One than in Clipper Cove.*

*No, it doesn't sound very nice, but during the winter in St. Barth we frequently swim in the lee of scores of anchored boats that don't have waste treatment or use pump-out stations. We've learned to live with it, as the water is so clear you can usually*



LATITUDE / RICHARD

*spot approaching problems. Besides, life is otherwise just so pleasant there that we don't even think about it.*

*One government agency in the Caribbean — we can't remember which — did a study of the health effects of pumped discharge from boats in Caribbean anchorages. As we recall, the detrimental health effects were slight, thanks primarily to the fact that almost all Eastern Caribbean anchorages are swept by strong winds and current that quickly whisk floating feces offshore toward distant Central America. In the few places where water isn't so clear and/or doesn't flow so freely — Falmouth or English Harbours in Antigua come to mind — we'd be less inclined to swim.*

### ⇕POLL POSITION

Contrary to what you suggested in *'Lectronic*, the results of the reader survey on the culpability of Deputy Perdock in the death of Lynn Thornton probably just ensures that a change of venue motion would be easily sustained. What judge could



# COME VISIT COYOTE POINT MARINA:

*The Peninsula's Complete Recreational Destination!*



## **BERTHING**

- Slips to 40' available
- 22' inside ties for \$85 per mo.
- Multihull side ties available
- Check out our rates!



## **FUEL DOCK & PUMP OUT**

- Open 7 days per week
- Gas and diesel available
- Check our prices
- Free pump outs



## **COYOTE POINT RECREATIONAL AREA – HOME TO:**

- Coyote Point Marina
- Poplar Creek Golf Course
- Coyote Point Park
- Captain's House Conference Center
- Beach, Picnic & BBQ Areas
- Coyote Point Yacht Club
- Dominic's Restaurant
- Magic Mountain Playground
- Coyote Point Museum
- Shoreline Trail

**COME FOR A VISIT – WE THINK YOU'LL STAY**

*Call us and mention this ad for a FREE One Night Guest Berth*

COYOTE POINT MARINA ~ 1900 Coyote Point Drive • San Mateo

**650.573.2594**

# SAFETY TETHER



- ORC Approved Offshore Tether
- Quick Release Inboard End
- Florescent Double Action Safety Hooks

The Hot Forged Advantage



**Wichard**  
www.wichard-usa.com



## LETTERS

deny that pre-trial publicity has influenced the jury pool?

Isn't the District Attorney an elected position? When is Hopkins up for re-election? If 70% of the voters disagree with him, perhaps he'll get his due at the next election.

Russ Irwin  
New Morning, Swan 44  
Sausalito

*Russ — If the results of the Lake County newspaper poll — that the overwhelming number of respondents think that Thornton's death was mostly or totally the fault of Deputy Perdock — are accurate, why would the defense want a change of venue?*

### ↑↓DINIUS' CASE IS VERY KAFKAESQUE

Yale Cordage, where I work, receives *Latitude 38* along with many other marine magazines each month. I have followed the Bismarck Dinius case that's the result of the boating death of Lynn Thornton on Clear Lake. It's amazing that such a Kafkaesque case could unfold in the United States.

A critical aspect of the case is whether the sailboat's running lights were on prior to Deputy Russell Perdock's powerboat slamming into the sailboat's aft quarter at high speed. If any of the bulbs were broken, experts can examine the filament and determine whether the light had been on or not. A heated filament will break differently than a cold one. The results of such examinations are commonly used by crash reconstruction experts to determine if someone's car directionals were on during an accident involving a turn. If done by a properly qualified person, this evidence will hold up in court.

However, if the authorities are on Deputy Perdock's side, it sounds as if it may be difficult to locate a qualified expert. And perhaps all the broken bulbs were removed and replaced with suitably altered ones?

I've never been able to understand why people who would never consider driving their cars full speed at night with no headlights would do the same thing on a boat. The results are often fatal. Last year we had a nighttime collision on Long Lake, Maine, between an 870-hp Sunsation Dominator powerboat and two people in a fishing skiff. The fishermen were killed, and the Sunsation left the water and proceeded quite a ways into the bushes before stopping. The 47-year-old skipper and his 17-year-old female companion were only slightly injured. More recently, there was another nighttime collision on Lake Winnepesaukee in New Hampshire, starring the owner of a marina and a smaller craft, again with fatal results.

Professional mariners try very hard to avoid groundings and collisions, as it usually leaves them 'on the beach' for the remainder of their careers. Maybe similar penalties need to hang over the heads of recreational powerboaters!

David Saunders  
Biddeford, ME

*David — It's our understanding that the defense hired an expert, who testified in the preliminary hearing that the sailboat's running lights had indeed been on when she was hit. In addition, a San Francisco television station found other witnesses — including a retired law enforcement officer — who also testified that the sailboat's running lights were on. So when the real trial begins next January, the prosecution will presumably have to try to convince 12 out of 12 jurors, beyond a reasonable doubt, that the forensic expert is an idiot and the independent witnesses are blind.*

*As we've said from the beginning, the case against Bismarck*



# BERKELEY MARINA



**Centrally located off Hwy. 80 at University Ave. • Fast Access to the Central Bay • Fuel Dock • Marine Center with 35 Ton Lift Capacity • Launch Ramp • Waterfront Hotel • Restaurants • Adventure Playground • 17 Acre Off-leash Dog Park • Picnic Sites • Deli and More...**

## Available Berths\*

<del>60' Upwind Double, Liveaboard. . . . . RENTED. . . . .</del> \$828.40/Mo.	40' Downwind Double, New docks . . . . .	\$346.80/Mo.
52' Upwind Double . . . . .	32' Upwind Double . . . . .	\$271.60/Mo.
52' Upwind Double, Liveaboard . . . . .	32' Upwind Double . . . . .	\$271.60/Mo.
40' Downwind Double, New docks . . . . .	<del>32' Downwind Single, Liveaboard. . . . . RENTED. . . . .</del>	<del>\$459.56/Mo.</del>
40' Downwind Double, New docks . . . . .	<del>32' Upwind Double. . . . . RENTED. . . . .</del>	<del>\$314.56/Mo.</del>
40' DW Double Liveaboard, New docks. . . . .	32' Upwind Double, Liveaboard. . . . .	\$459.56/Mo.
<del>40' Downwind Double, New docks . . . . . RENTED. . . . .</del>	30' Downwind Single . . . . .	\$280.20/Mo.
40' Downwind Double, New docks . . . . .	<del>28' Upwind Single, Liveaboard. . . . . RENTED. . . . .</del>	<del>\$404.39/Mo.</del>
40' Downwind Double, New docks . . . . .	28' Upwind Single . . . . .	\$259.40/Mo.
<del>40' DW Double, Liveaboard, New docks RENTED. . . . .</del>	25' Upwind Double . . . . .	\$217.80/Mo.
<del>40' DW Double, Liveaboard, New docks RENTED. . . . .</del>	24' Downwind Double . . . . .	\$177.12/Mo.
40' Downwind Double, New docks . . . . .	<del>24' Downwind Double. . . . . RENTED. . . . .</del>	<del>\$177.13/Mo.</del>
40' Downwind Double, New docks . . . . .	20' Downwind Double . . . . .	\$137.40/Mo.

Berths subject to availability

\*all rental agreements & permits subject to approval of application and vessel inspection. Customer responsible for 1st month rent plus deposit, and all applicable fees.



**CITY OF BERKELEY**  
PARKS RECREATION AND WATERFRONT

**Berkeley Marina Office**  
**201 University Ave. • 510-981-6740**

Visit our website at: [www.ci.berkeley.ca.us/marina](http://www.ci.berkeley.ca.us/marina)

## Not Using Your Boat?



**STORE  
IT**

## Want To Sell Your Boat?



**STORE  
IT**

## Want to Dry Out Your Boat?



**STORE  
IT**

## Leaving the Country?



**STORE  
IT**

## Want to Save Money?



**STORE  
IT**

**DRY STORAGE**  
**\$3.75/ft**  
**Power & Sail**



**CELEBRATING OUR 50<sup>TH</sup> ANNIVERSARY**

**NAPA VALLEY MARINA**

1200 Milton Road • Napa, CA 94559

**(707) 252-8011** • Fax (707) 252-0851

[www.napavalleymarina.com](http://www.napavalleymarina.com)

Marina • Boatyard • Chandlery • Brokerage

Dealers for  
**YANMAR**

**Interlux**  
yachtpaint.com

Distributors for *Brownell*  
Boat Stands

## LETTERS

*Dinius is so preposterous that we don't even believe the Lake County District Attorney thinks he can get a manslaughter conviction. How could he after the recent Lake County Record-Bee poll showed the great majority believe Perdock — who still hasn't been charged — was primarily if not entirely at fault? No, it seems that the prosecution's strategy is to use the phoney Bismarck trial to obscure the fact that their main intent is to shield Deputy Perdock from prosecution.*

*With Thornton having been killed as a result of a boat driven at high speed in the dark on Clear Lake, you'd think they had learned from the tragedy and imposed a 5 mph speed limit on the lake at night. Will it surprise you to learn that they haven't? What will it take for them to learn that speed kills on the water as well as the roads, particularly at night.*

### ↑↓ **SOCRATES WILL KEEP SAILING**

I was very sad to learn that Jeanne Socrates lost her Najad 361 *Nereida* on a beach in Mexico just a few miles shy of completing her circumnavigation. I had somewhat followed her adventures through the Singlehanded TransPac and then through *Latitude's* updates of her sail almost all the way around the world. I'm glad that she is safe and made it as far as she did. I'm sure that she'll continue sailing, because when it gets in your blood, there is no stopping it.

Greg Clausen  
Wisdom, Santana 30  
Marin County

*Greg — In addition to sailing being in Socrates' blood, the thing that will keep her back on the water is a nice settlement from Lloyds of London. Yes, she's one of the few singlehanders we know who popped for the hefty premiums for offshore singlehanded coverage.*

### ↑↓ **CHARTERERS DO THE CRAZIEST THINGS**

I have been cruising the waters of Thailand off the coast of Phuket for several years aboard my Jeanneau 41 *Koumbele*, and have frequently seen charterers do strange things on boats. But the following is perhaps the silliest.

A local charter outfit, run by a fellow named Max, chartered a new Wharram 38 catamaran to a customer for a two-day sail. While sailing in 15 knots and flat seas, a headstay shackle parted, and the rig came down, falling onto the yacht itself. There was little harm done to the crew or boat. The charterers then proceeded to unfasten the entire rig — including the turnbuckles, Pro-Furl roller furling, sails, and mast — and jettison it over the side! They had probably read some wild sailing story where a boat was dismasted in a terrible storm and the crew had to throw the rig over for safety. To make things worse, they didn't bother to take a GPS fix, so it was impossible to retrieve anything.

The final irony is that when they returned to the base, the charterers complained to Max that the boat didn't have any bolt cutters aboard, as it would have made it easier to dump the rig over the side.

P.S. I love reading *Latitude* online here in Thailand.

Richard Buckminster  
*Koumbele*, Jeanneau 41  
Phuket, Thailand

*Richard — That's a pretty good charter story. It ranks up there with the folks who called a charter base in the British Virgins and asked to have more chain and anchors delivered to their boat. They assumed you just used them once, then left them on the bottom when taking off again.*



BayRisk *Classic*

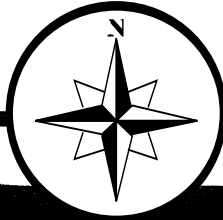

**BayRisk** Insurance Brokers, Inc.

800-647-2025

Visit our Website [www.bayrisk.com](http://www.bayrisk.com)

1920 Minturn Street • Alameda, CA 94501

# WHALE POINT MARINE & HARDWARE CO.

**A FAMILY OWNED & OPERATED BUSINESS FOR THREE GENERATIONS**  
**ACE Hardware**  
 MARINE PARTS & ACCESSORIES, PLUS A COMPLETE HARDWARE STORE

Go to **WhalePointMarine.com** for additional discounts!

## PORTABLE HEATER

Indoor safe propane heater.



**Mr Heater**  
 4,000-9,000 BTU: **NOW \$99<sup>99</sup>**

## COLEMAN Solar Panels



1 Watt **Now \$24<sup>99</sup>**  
 5 Watt • **Now \$59<sup>99</sup>\***  
 18 Watt • **Now \$169<sup>99</sup>\***  
 Needs also Controller \$26.99

## SILVER MARINE Inflatables



Length..Width.....Max.....Floor.....**NOW**  
 7'8" ... 4'1" ... 2.7hp .. Roll-up ..... **\$699**  
 8'2" ... 4'3" ... 4hp .. Roll-up ..... **\$799**  
 9'8" ..... 5' ... 9.9hp ... Wood .. **\$1199**

## WALKER 8'-10' Dinghy

Very affordable. Converts from row boat to sailboat to motorboat. Polypropylene hull. Comes with oars. Sail kit optional.



10' Dinghy: **\$995<sup>00</sup>**

**8' Special \$699<sup>00</sup>**

## VECTOR POLISHER

1000-3000RPM



**NOW \$69<sup>99</sup>**

## DECK BRUSH with Handle



Extra long handle (5ft) with aluminum no-rust, treaded tip. **Now \$13<sup>99</sup>**

## TOILET SEAT Marine

Isn't it time to update that old toilet seat?



**NOW \$19<sup>99</sup>**

## FILTER 500 FGSS by Racor



**Filter Element**  
 West \$10.55  
**Whale Pt \$8<sup>99</sup>**

**Filter Unit**  
 West \$199.00  
**Whale Pt \$169<sup>99</sup>**

**205 Cutting Blvd, Corner of 2nd, Richmond**  
**510-233-1988 • FAX 233-1989**  
 Mon-Sat: 8:30am - 5pm • Sun: 10am - 4pm  
 Email: [whalepoint@acehardware.com](mailto:whalepoint@acehardware.com)

## LETTERS

### ↑↓ GORDO'S COMPETITOR IS SO DAMNED NICE

Been shorted of fuel by Gordo's at Turtle Bay like the Hartfords on *Nomotos* who wrote in to complain about it last month? Uh, hell yeah! When a buddy of mine noticed that his fuel can was nearly a gallon short and complained, it got to the point where Enrique threatened him physically. I think the Hartfords got off lucky if their tank was filled to within inches of the top.

The people at Gordo's got on the radio and told us they had "cleaner fuel" than their competitor. In fact, they claimed that their competitor's fuel would "ruin your engine" and that their competitor was dishonest. In my life experience, I've never heard the reputable dealer of anything directly trash a disreputable competitor, but I've had plenty of dishonest guys tell me how honest they were.

I also heard a rumor that the *federales* had to be called in during the FUBAR powerboat rally because Enrique was threatening to shoot his competitor — and their customers! I'm not saying this is true, just that I heard the rumor.

What I do know to be true is that we were given fantastic service by Gordo's competitor and her extended family, and that there's no reason for anyone to use Gordo. Unfortunately, I can't remember the name of the woman who is the competition, but her son took me ashore in their skiff and then carried me — I'm six-feet and 160 pounds — so I wouldn't get wet! Her grandson, who is maybe 12, drove me into town and picked me up again. We'd agreed on \$5 for the ride, but how could I not give them \$10?

Frankly, I'd gladly pay Gordo's competitor a vig on the fuel just because they are so damned nice and friendly. But you don't have to because they're honest, too. Further proving my point, when I asked them, "What's up with Gordo?" they rolled their eyes and shrugged. Sort of like a reputable business person would have done here in the States.

Aaron Lynch  
 Ra, Jeanneau Sun Odyssey 54  
 Redondo Beach

### ↑↓ I'M JUST HAPPY THEY HAVE FUEL AT ALL

I can only assume the Hartfords on *Nomotos* were kidding when they complained about Gordo's. The folks in Turtle Bay provide a huge service to the boating public by providing fuel at all — much less at very favorable prices. And someone has a beef over a couple of gallons? What a very depressing nine years it must have been for them to sail around the world with an attitude like that.

I have fueled in Turtle Bay multiple times. Most recently I took on 140 gallons in April while doing a Bash. I was very happy to get fuel at all, and honestly expected to pay about 40% more than I did. The fact that it was delivered to the boat was a bonus. I knew the tank capacity of my boat and received what I paid for.

I have yet to see signs in Mexico, like the ones in the United States, that read "We reserve the right to refuse service to anyone." But with an attitude like the Hartfords', it won't — and shouldn't — be long!

Capt. Pete Sauer  
 Big Sky Yacht Delivery  
 Montana

### ↑↓ SERVIOS ANABELLE IS THE NAME

We were in Turtle Bay at the same time as the Hartfords of *Nomotos*, the ones who wrote in last month complaining about Gordo's fuel service. We also took on the fuel we needed to complete our 25+ year circumnavigation — but we got our





# Baja Sur

Jacques Cousteau considered the Sea of Cortés the world's largest aquarium. Come view it from within.

The Sea of Cortés is not only winter home to the grey whales, it has more marlin than any area of the world as well as thousands of other colorful creatures that are *not* to be observed from afar. So, to get an up-close view, and to experience the adventure of this unique environment, just dock your vessel at any one of the four superb marinas in La Paz and, at your leisure, wander the streets and byways of this picturesque town, cruise to the fishing grounds, or explore a quiet island, cove or inlet. Then as Mr. Cousteau preferred, jump right into the aquarium. You'll never feel so alive.

For more information visit:  
[marinacostabaja.com](http://marinacostabaja.com); [marinadelapaz.com](http://marinadelapaz.com);  
[marinapalmira.com](http://marinapalmira.com); [clubcantamar.com](http://clubcantamar.com)

**México**  
BEYOND YOUR EXPECTATIONS

Come Explore the Richness of Baja Sur.

Baja California Sur

[mybajasur.com](http://mybajasur.com)

| 877 MY BAJA SUR

**"Your full service,  
fully stocked canvas super store."**



*Matthew Hunt*

**Build it  
Repair it  
SAVE  
\$\$\$!**

**Online Shopping, Tips,  
Instructions, Product Videos**

**Kits**



**Thread**



**Tools**

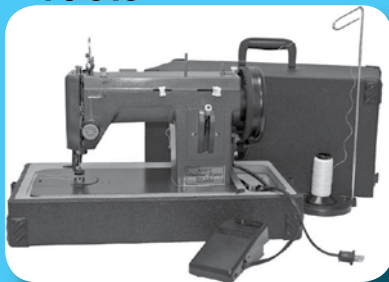

For a free supplies catalog call 1-800-348-2769 or  
visit us online at [www.sailrite.com](http://www.sailrite.com)



**1-800-348-2769  
[www.sailrite.com](http://www.sailrite.com)**

## LETTERS

fuel from Gordo's competitor, whose *panga* is called *Servios Anabelle*. We're sure *Latitude* folks and others have seen their big sign on the hill above the beach just west of the center of the village. They say they are available 24/7.

The *Servios Annabelle* guy first visited us in his *panga*. Then he came alongside in a real fuel barge, complete with a proper meter and filters. In our opinion, the amount of fuel dispensed was accurate. *Servios Annabelle* was recommended to us by Ray of *Adios* who, along with Mike of *Las Otras*, had done six Baja Bashes this year as of June. Ray had nothing but good to say about them.

Paul & Susan Mitchell  
*Elenoa*, 36-ft steel ketch

Back in San Diego after a quarter of a century of cruising

*Paul and Susan — We're familiar with Servios Annabelle and have been happy with the amount and quality of fuel that we've purchased from them. However, it seems like there's an ongoing legal battle between Gordo and them, and sometimes Servios Annabelle seems to have been shut down.*

### ↑↓WE CONSIDER IT A 'GRINGO TAX'

We got fuel-gouged at Turtle Bay, too. Our only experience with Enrique at Gordo's is when we arrived at Turtle Bay in November of '07, a few days after the Ha-Ha had passed through. We'd spent the month before in Ensenada, then sailed south by ourselves to anchorages at Islas San Benito and Isla Cedros before moseying into Turtle Bay. We only needed 20 gallons or so of fuel, so for us a gouge of 10% wasn't going to break the bank. But to make a long story short, yes, like others, we got gouged by 10-20%.

To make the long story long, Enrique at first delayed by about 12 hours the *panga* fuel delivery that he'd promised. At the time we hadn't been in Mexico very long, and thought this was 'the Mexican way of doing things' — as opposed to a ploy to encourage us to buy whatever he offered when he eventually showed up. It was almost sunset by the time Enrique's two boys — one might have been all of 20 — came to our boat in the *panga*. Neither of the two had ever operated the jury-rigged fuel siphon system on Enrique's *panga*. We had to show them how, as well as provide the battery for the power necessary to make it work.

As we and the two boys were transferring the fuel into our boat's tanks, Enrique was nowhere to be found. But when it came time for us to pay, he showed up in a high speed *panga* to calculate the charges — and to make sure all the cash went directly to him. The price turned out to be more than the rates that he'd had quoted other boats over the radio. We complained mildly, but at the time chose not to push the matter because we wanted to take off at first light. And because 'it was Mexico'. However, I made it a point to tip the two *panga* boys in Enrique's presence — which visibly made him unhappy and the boys uncomfortable. I wonder if Enrique let the boys keep the tip? We got out of Turtle Bay the next morning and never looked back.

I want to emphasize that this is by far the worst gouging experience we've seen so far in our travels in Mexico. And we prefer an up-front 'dockage fee' that we've had to pay at some fuel docks as opposed to Enrique's way of doing things. And dockage fees for fueling are certainly not universal in Mexico.

Turtle Bay is unique because the major cruising guides — and the Ha-Ha and the FUBAR powerboat rallies — publicize it as a destination not to be missed. I think those rallies have, in part, created the price-gouging situation in Turtle





# ULLMAN SAILS

The Sailmaker to Champions!

**THE FASTEST SAILORS CHOOSE  
THE FASTEST SAILS ON THE PLANET**

**SC50 Horizon**  
Jack Taylor  
Carbon D4 Main and  
Carbon GPL #1 Genoa



**Melges 24 Pegasus 505**  
Dave Ullman  
Dacron Main, Technora Jib  
and AirX Spinnaker

**Andrews 45 Locomotion**  
Ed Feo  
Carbon GPL Main and  
Carbon GPL Light #1 Genoa



**CONTACT AN ULLMAN LOFT OR REP FOR SERVICE AND SALES**

## LOFTS:

**Newport Beach**  
(714) 432-1860  
2710 S. Croddy Way  
Santa Ana, CA 92704  
Dave Ullman  
Bruce Cooper  
Steve Beck  
Erik Shampain  
One Design  
Charlie Ogletree

**San Diego**  
(619) 226-1133  
2805 Canon  
San Diego, CA 92106  
Jim Clinton  
Tom Niebergall  
Chuck Skewes  
Ty Hokanson

**Long Beach**  
(562) 598-9441  
6400 Marina Drive #9  
Long Beach, CA  
90803  
Bryan Dair  
Steve Beck  
(562) 243-9710

**Marina del Rey /  
King Harbor**  
Mike George  
(310) 645-0196  
Steve Beck  
(562) 243-9710

**Ventura**  
(805) 644-9579  
3639 E. Harbor Blvd.  
#111  
Ventura, CA 93001  
Gary Swenson  
Deke Klatt

**Santa Barbara**  
Ken Kieding  
(805) 965-4538  
Gary Swenson  
(805) 644-9579

**Santa Cruz**  
Brent Ruhne  
Ruhne Racing  
(831) 295-8290 mobile

**Seattle**  
Jeff Carson  
Marine Servicercenter  
(206) 383-8618



Visit our website: [www.ullmansails.com](http://www.ullmansails.com)

# BUILT TO LAST. BUILT TO WIN.



Skip Allan, *Wildflower*, Singlehanded TransPac winner.

On Saturday, July 12, 2008, 22 sailboats ranging in size from 20' to 60' began their 2,120-mile singlehanded race from San Francisco to the beautiful Hanalei Bay, Kauai. Nineteen boats finished before the noon deadline 21 days later. On corrected time, Skip Allan in his Custom Wylie 28 *Wildflower* won the 30th anniversary edition of the Singlehanded TransPacific Yacht Race! His secret weapon? Sails from his brother Scott Allan, owner of the Annapolis UK-Halsey loft. Some sails in his current arsenal were built in 1994. Built to last. Built to win.

Call today for a quote on the best sails available.



## NORTHERN CALIFORNIA

451 W. Atlantic, Suite 115, Alameda, CA 94501

(510) 523-3966

Sylvain Barrielle • Synthia Petroka • Jason Crowson

[www.ukhalsey.com](http://www.ukhalsey.com) • [sanfrancisco@ukhalsey.com](mailto:sanfrancisco@ukhalsey.com)

## LETTERS

Bay. I want to reassure *Latitude* readers that the rest of Mexico we've seen is not like Turtle Bay, and after having lived here continuously for the past nine months, sailing and traveling inland in six states, we've found that most folks in Mexico are like most folks everywhere else. They work hard, getting along by being honest and helpful to all us goofy *gringos*.

Yes, we sometimes have to pay a bit higher prices for services, but we always chalk up a mild premium as a 'language barrier' or 'gringo tax' that's not worth arguing about. And yes, we do complain on the rare occasions — once, actually — when the charges were unreasonable. Now that we have more experience in the country, we believe the reason Enrique is doing what he is doing is because Turtle Bay receives a large influx of boaters new to Mexico during the Ha-Ha and FUBAR rallies that are dropped into his lap like ripe fruit from a tree. He will never see most of those boats again, so why shouldn't he charge extra for fuel? Wouldn't you? I don't want to be harsh about this because I like *Latitude*, but I also feel that due to their economies of scale, it must fall to the organizers of the Baja Ha-Ha and FUBAR to curb the fuel-gouging in Turtle Bay. If worse comes to worst, Ha-Ha'ers can top off their tanks in Ensenada at the Hotel Coral Marina and in Cabo San Lucas, bypassing Turtle Bay altogether, but still enjoy the camaraderie of being part of a cruising rally.

Marianne Smith & Gary Barnett  
*Gallant Fox*, Malo 39

In Mazatlan for hurricane season

*Marianne and Gary — We don't mind you suggesting that the Ha-Ha is responsible for price gouging fuel at Gordo's in Turtle Bay, but we think there are two good reasons not to believe it. First of all, it's well known that price gouging has been going on at Gordo's for more than 30 years — in other words, more than 15 years prior to the founding of the Ha-Ha. Second, it's not like Gordo's has a lock on the Ha-Ha business. Most of the Ha-Ha boats don't have to refuel because they sail much of the first leg. If they do need fuel, it's likely to be a relatively small amount, which they can purchase as easily from competitors Servios Annabelle, the Pemex station in town, or even from other cruisers. And because of the Ha-Ha net, anybody who feels they got shorted by Gordo's can immediately alert the rest of the fleet.*

*In the case of your having to wait 12 hours for the fuel to be delivered, our reaction would indeed be "that's the Mexican way of doing things." And we make that judgement based on having stopped in Turtle Bay every year for 15 years. They have a different sense of time there. Besides, if macho Enrique is going to put a little bite on you, he's not going to waste 12 hours trying to be cute about it.*

*You say you were charged a different price than was quoted other boats over the radio. Is it possible that the other boats were going to be taking on large quantities of fuel? Discounts on volume fuel purchases are standard in the United States, and may be in Mexico, too.*

*As for your making a point of tipping the boys in front of Enrique, why would you do something that clearly made him unhappy and the boys uncomfortable? That's passive-aggressive as hell. How would you like visitors from Mexico coming into your place of business and telling you how to compensate your employees and undermining your authority? If you saw that your gesture was making everyone feel bad, we think you should have figured out a more subtle way to tip the boys.*

### ↑↓ TELL ME SOMETHING I DON'T KNOW

I can't believe it! Could it really be possible that some fuel





# HAULOUTS 20' to 80'

**HAULOUTS ON SHORT NOTICE...CALL US!**



**NORTHERN LIGHTS**

**GENERATOR SALES & SERVICE**

**WUGGER**

**MARINE ENGINES SALES & SERVICE**

**YOUR NEW FULL SERVICE VOLVO PENTA DEALER IN THE BAY AREA**

**PETTIT marine paint**

**Sea Hawk PREMIUM YACHT FINISHES**

## **FULL SERVICE BOATYARD:**

- ✓ COMPLETE PROPELLER SHOP
- ✓ ELECTRICAL REPAIR & INSTALLATION
- ✓ FIBERGLASS BLISTER WORK
- ✓ LPU PAINTING
- ✓ COMPLETE MACHINE SHOP
- ✓ SHIPWRIGHTS - CAULKING & CARPENTRY
- ✓ GAS & DIESEL ENGINE SERVICE
- ✓ MAST & RIGGING REPAIR
- ✓ SANDBLASTING & EPOXY COATINGS
- ✓ FIBERGLASS & GELCOAT REPAIRS
- ✓ USCG CERT. WELDERS - STEEL/ALUMINUM
- ✓ INSURANCE WORK WELCOME

**88-TON TRAVELIFT HANDLES UP TO 23' BEAM!**

**Online reservations now available at [www.baymarineboatworks.com](http://www.baymarineboatworks.com)**

**BAY DESIGN & ENGINEERING**

**1-800-900-6646**  
 (510) 237-0140 • Fax: (510) 237-2253

**BAY PROPELLER**

**STEVE TAFT, MANAGER**  
**310 WEST CUTTING BLVD. • POINT RICHMOND, CA 94804**

**COMPLETE PROPELLER SERVICE**



**South Beach Harbor is a great way to experience San Francisco. Boats of all sizes are welcome in our protected deepwater harbor. Bring your boat to South Beach and enjoy all the attractions of the city.**



- Two guest docks for boats up to 125'**
- 20 guest berths up to 50'**
- Casual and fine dining nearby**
- Adjacent to AT&T Park**
- Easy access to transportation**
- 24 hour security**
- Free pump-out stations**



**For Reservations:**  
 415.495.4911 (x0)  
 fax: 415.512.1351  
 sb.harbor@sfgov.org  
 www.southbeachharbor.com

## LETTERS

pumps in Mexico are set to deliver something less than the indicated amount? Oh my! The next thing you know, people will discover that it rains in Oregon in January.

Jimmie Zinn  
*Dry Martini*, Morgan 38  
 Richmond

### ↑↓WHAT A BUNCH OF WHINERS

No wonder the guys in Turtle Bay always take care of the sportfishing boats first! I've sailed and driven boats to Turtle Bay a number of times. Considering its remote location, I'm always surprised that there is anything there — let alone diesel at a reasonable price. Maybe Senator Gramm was correct when he said there are too many "whiners" in the United States.

Chris Maher  
*Blarney*, Morgan 38  
 Alameda

*Chris — Did Gramm include the Canadians? The Hartfords are from Canada.*

*We'll have more responses to Gordo's business practices in the next issue, as there has been a lot of diverse reaction.*

### ↑↓WHAT IS AND IS NOT A FOLKBOAT

In the July 21 *Lectronic*, you wrote, "Tom Kirschbaum's International Folkboat *Feral* is one of the 'poor' boats experiencing lighter winds." *Feral* is an 'IF Boat' — nothing more and nothing less. She is not a so-called 'International Folkboat'.

True, when the IF Boat was introduced in Sweden several decades ago, the designers intended to capitalize on the immensely popular wooden Nordic Folkboat. Although the IF was made of fiberglass, the hull and many features were copies of the Nordic Folkboat. After litigation, however, the imitator was forced to abandon the use of the word 'Folkboat' in any association with the fleet. The press should respect this.

Olof Hult  
 Culver City

*Olof — Tord Sundén, the man credited with designing the Nordic Folkboat — of which there is a thriving fleet right here on the Bay — also worked up a more 'cruiser-friendly' version*



LATITUDE / LADONNA

*that was built by Swedish yard Marieholms Bruk for 17 years. During that time, more than 3,400 of these stout little boats were launched.*

*The design was originally introduced in 1967 as the International Folkboat, and you're right that in Europe*

**Whether you call it an International Folkboat or IF Boat, Tom Kirschbaum's 'Feral' sailed just as sweetly across the Pacific.**

*they are known as IF Boats, as the hard-core Nordic Folkboat aficionados felt the name was misleading. But in the U.S., the name stuck.*

*Chris Herrmann, president of the San Francisco Bay Folkboat Association, says "I've heard of International Folkboats referred to as IF Boats, IF Folkboats, Marieholm Folkboats, and International Folkboats somewhat interchangeably. But*



# South Beach Sailing Center

## South Beach Riggers

**Winning  
Technology for  
the Hot Race or  
the Casual Cruise**

- Expert advice, sales and splicing of Vectran, Spectra, Technora, and Dacron by our certified splicer
- Professional survey and tune for your rig
- Standing and running rigging replacement
- Fabrication and hydraulics
- More than 100,000 miles racing and cruising experience



### TWO LOCATIONS

**399 Harbor Dr. • Clipper Marina • Sausalito • 415.331.3400**  
**Pier 40 • South Beach Harbor • San Francisco • 415.974.6063**

## The difference between a boat and a yacht



- Mobile Service:  
*We Deliver!*
- Washing
- Waxing
- Varnishing
- Interior Cleaning



## Westwind

Complete Yacht Care

*Serving the entire Bay Area for  
more than 20 years*



**(415) 661-2205**

Pier 40, South Beach on the Embarcadero • San Francisco

Call Toll Free **888-828-6789**

westwinddetailing@sonic.net

[www.boatdetailing.com](http://www.boatdetailing.com)



## CAL MARINE ELECTRONICS



Sales - Installation - Service - Integration

- Radar
- VHF
- GPS
- Antenna
- Auto Pilot
- Instrumentation
- Chartplotter
- HF/SSB / e-mail
- Electrical
- Checkup

Serving SF Bay with name brand products  
and professional quality services since 1952

**Done right ... priced right.**

**415-391-7550**

Pier 40 The Embarcadero, SF, 94107  
[www.calmarineelectronics.com](http://www.calmarineelectronics.com)

*Design, Fine Yacht Upholstery,  
Fabrication, Etc.*



YACHT: LIN MAR

**NORTH  
BEACH  
MARINE  
CANVAS**

**415.543.1887**

[nbmc@earthlink.net](mailto:nbmc@earthlink.net)

[www.northbeachmarinecanvas.com](http://www.northbeachmarinecanvas.com)

Pier 40, The Embarcadero  
South Beach Harbor, San Francisco

Pier 40 • South Beach Harbor • San Francisco

# FAR-OUT GENNAKER SAILING...



## ...with an extendable Seldén gennaker bowsprit

- Gives the gennaker more clear air
- Facilitates rapid gybing
- Always ready for quick extension
- Makes for fast and efficient gennaker handling
- Can be fitted to most yachts
- Complete kit for deck mounting
- Available in carbon or aluminium

[www.seldenmast.com](http://www.seldenmast.com)

 **SELDÉN**  
for sailing

Rig solutions for dinghies, keelboats and yachts. Aluminium and carbon spars. More than 750 authorised dealers worldwide. Seldén and Furllex are registered trademarks of Seldén Mast AB.

Seldén Mast Inc. Tel 843-760-6278, [info@seldenus.com](mailto:info@seldenus.com)

## LETTERS

*it's probably more common to hear them called International Folkboats or Marieholm Folkboats." Even Bay Area author Dieter Loibner refers to them as "International Folkboats" in his book The Folkboat Story.*

*Semantics aside, IFs are different enough in design that they are not class-legal to race in the local Folkboat fleet. But that shouldn't stop their owners from starting their own fleet.*

### ↑↓ CRUISING WITH A \$1,000 A MONTH FUEL HABIT

Our 50-ft Mikelson powerboat *Dos Abogados IV* has twin 435-hp Cat diesels — and a carbon footprint like Sasquatch. We went down to Mexico with the FUBAR powerboat rally in November and stayed through mid June. It was our second time down there, having done it before in the winter of '06. We bought a lot of fuel — something like 6,000 gallons. Mainly, we were always glad to just be able to get fuel.

We have Floscans and a Tank Tender, and we feel that we never got shorted. We know it was all good clean fuel because we never had to change a filter. I don't think we ever paid more than \$2.45/gallon. Sometimes it might have been a dime a gallon or so less. These prices include the docking charges at some fuel docks. The Mexican government and Pemex tell the fuel docks what to charge, so the 'bite' was the docking charge. That said, we still felt we were getting a great deal. In fact, we hope it continues when we're able to go back again — maybe in '10.

We generally took on about 600 gallons at a time: at Ensenada; Turtle Bay (Annabelle's *panga*, not Gordo's); Cabo (at the cheaper place on the left as you enter); Las Hadas (in the little marina from the big white fuel tank); Puerto Vallarta (the Straits of Opequimar); Mazatlan (the new facility in the back by Marina Mazatlan, not at El Cid, aka El Surge); La Paz (Costa Baja, although we stayed at Marina de la Paz); Puerto Escondido; La Paz again; Cabo again; Turtle Bay again; and Ensenada again, where we figure we were the last boat to get a full load with no wait on June 10, 2007.

We're now at Avalon, Catalina, still burning the inexpensive Mexican diesel. We're hoping to make a long weekend of it — probably in October — for a fuel run down to Ensenada. The *San Diego Union* regularly reports that the Mexican diesel is heavily subsidized by the government. Actually, it's the other way around, as the Mexican government is subsidized by the oil revenues of about \$90 billion a year. Mexico has three major oil fields. One is not really the good stuff, a second is not really being developed, and the third is good but is producing significantly less than in prior years. Mexico can develop more oil fields but has been unable to because of the Pemex unions and political interests that prevent the country from getting the necessary technical help and capital to develop those fields. So I'm not holding my breath waiting for that to happen. I'm just selfishly hoping we can make one more good run down to Mexico, during which time we'd concentrate in the Sea of Cortez.

Although we're powerboaters, we read *Latitude* all the time. Currently, we're surrounded by sailboats here in Avalon. Many of the powerboats are being left on their moorings all the time instead of being taken back and forth each week by their owners. With \$5 diesel, the owners are finding it much less expensive to commute back and forth by ferry. As a result, we're told that some local businesses are off by as much as 50%. It seems very quiet, too, as the boats are here but the people aren't.

My wife and I are very glad we left work and abandoned everything for two six-month adventures in Mexico. I always said that we were going to be among the last to be able to



# TO GET OUT THERE, START HERE: MARINA VILLAGE

**HOME TO THE  
WORLD'S  
BEST BROKERS**

**OPEN BOAT WEEKEND  
SEPTEMBER 13-14**

## Sail California



Santa Cruz 37

## Farallone Yachts



Ranger Tugs

## Passage Yachts



Alerion Express 28

**Farallone Yachts  
Catalina  
(510) 523-6730**

**See at Fall Boat Show  
September 6-14**



J/105



Catalina 350



Beneteau First 45

**Passage Yachts  
Beneteau · Island Packet  
Wauquiez · Alerion  
(510) 864-3000**



J/122



Catalina 375



Island Packet SP 41

**Sail California  
J-Boats · Sabre  
Santa Cruz Yachts  
(510) 523-6730**



Sabre Spirit



Catalina 470



Wauquiez 41 Pilot Saloon

**NEW!**  
**Marina Village  
welcomes broker  
McGrath Yachts  
(510) 521-5020**

**Call A Marina Village Broker to List Your Boat Today!**

## MARINA VILLAGE YACHT HARBOR

**Much More than Just a Marina**

**(510) 521-0905 • [www.marinavillageharbor.com](http://www.marinavillageharbor.com)**

**Want to start sailing right? Upgrade your skills? Call J/World (510) 522-0547**





# Don't Let This Happen To You!

## Marine AIS Receivers

Give your navigation software or chartplotter  
the power to see shipping traffic.

Prices start  
from only  
**\$189!**



**Why Leave Your –  
And Your Family and Crew's –  
Safety to Chance?**

Commercial ships now use AIS transponders.  
Map nearby ships with supported  
navigation software and chartplotters  
connected to one of our low cost AIS Receivers.

For more information visit:

**www.MilltechMarine.com**

Or call us at:

**Milltech Marine  
(206) 299-2217**

## LETTERS

cruise under power — I just didn't realize that it was going to come to an end so quickly. If our powerboat becomes a 'Catalina barge', then that's the way it goes. We're beyond 50, so we won't be changing boats or learning how to sail. Nonetheless, we have many good friends who are sailors.

John Houts  
Dos Abogados IV, Mikelson 50  
Southern California

*John — We take no pleasure in the predicament of powerboaters, but we do have mixed emotions about powerboats. As fellow mariners, we want powerboaters such as yourself to be able to follow your passion. On the other hand, we and everyone else who is becoming more resource-aware can't help looking askance at relatively inefficient uses of any natural resource. Powerboating doesn't quite reach the 'let them eat cake' level of flying around in private 757 jets — as is not uncommon by people like our past presidents — but neither is it the most socially responsible use of oil. Fuel prices temporarily tumbled in August, but there is no way they aren't going to surge again in the next 5-10 years. When they do, we think society is going to cast a jaundiced eye at the more inefficient users of oil.*

*And it would seem as though the future is going to get tougher on powerboaters on an individual level, too. It's only by pure luck that West Coast powerboaters live in a country where fuel is half the price of most of the rest of the world, and that the country on our southern border, Mexico, sells diesel at a ridiculous 50% discount onto our already comparatively low prices. Imagine if you'd wanted to cruise French Polynesia, the Med, or most anywhere else in the world, where diesel sells for close to \$10/gallon. The fuel bill for your six-month jaunt would have been \$60,000, not \$15,000. Ouch! Even worse is the likelihood that at some point officials in Mexico — where the huge low-income segment of the population has been suffering from the dramatic increases in the cost of food — are going to start feeling the heat for subsidizing the outsized fuel habits of foreigners with big boats.*

*We can understand folks at your age making the decision to hold pat with your boat, even if it means your future cruising might be somewhat limited. But for younger boat buyers, Bob Dylan sang it best: "You don't need a weatherman to know which way the wind blows."*

### ↑↓ CLASS B TRANSPONDERS NOT APPROVED IN THE U.S.

I really like *Latitude* and *Lectronic*, but I think your first *Lectronic* report about Class B AIS units with transponders being available at West Marine is incorrect. The Class B transponders haven't been approved by the FCC yet — despite the Coast Guard and everyone else wishing they'd get on with it already.

For those who will be sailing outside of U.S. waters, Class B AIS units with transponders are readily available. The Class A AIS units, all of which have both receivers and transponders, are pretty expensive.

I don't have AIS on my boat but have used it doublehanding my friend's Mini-Transat *Dingo*, and I can confirm that it's really cool to see the ships on the chartplotter — especially if you're in the fog. With a lot of ocean races using the channel marks as racing marks, it's nice to have some idea of what ships are out there.

Mike Holden  
California State University Maritime Academy

*Mike — Thanks to some bad information and shoddy research on our part, we were wrong in our initial *Lectronic* re-*



# Better Sail Control



*now requires less effort...*

Garhauer's adjustable genoa car system is the answer to leaving the cockpit and going forward to move the genoa car with every wind shift and sail adjustment.

Experience better sail control with less effort. With four to one purchase, you can now easily control the travel of a block on any track from a single line led aft.

This is a four piece system consisting of two control cars and two end controls (port & starboard). A single line threads thru the two horizontal blocks on the easily-installed track cars for each track. Your genoa sheet slides thru the pivoting vertical block and back to the winch.

Available in track widths of 1 and 1-1/4", built with rock solid durability that all Garhauer hardware is known for.

Now tack better and spend less:

**E-Z G-1UB 1 in. track \$242.00**

**E-Z G-2UB 1-1/4 in. track \$302.50**

**E-Z G-3 1-1/4 in. track \$363.00**

**optional swivel cams available: \$96.80 per pair**

**for sailboats  
25-30' LOA**



**E-Z G-1UB**

**Optional  
swivel cam on slide**

**for sailboats  
30-36' LOA**



**E-Z G-2UB**

**Optional  
swivel cam on slide**

**for sailboats  
37-47' LOA**



**E-Z G-3**

**Optional  
swivel cam on slide**



1082 West Ninth Street,  
Upland, California 91786

Phone: (909) 985-9993  
FAX: (909) 946-3913

email: [garhauer@garhauermarine.com](mailto:garhauer@garhauermarine.com)  
<http://www.garhauermarine.com>



**J** the  
performance  
sailing  
WORLD school

800-910-1101  
www.sailing-jworld.com

"Still the Best in the Business!"  
- Practical Sailor

Limited Berths Still Available:

## 2008 Cruise to Mexico



**The J World Annual Cruise to  
Puerto Vallarta begins Mid Oct....**

- Leg I** - San Francisco to Santa Barbara
- Leg II** - Santa Barbara to San Diego
- Leg III** - San Diego to Cabo - The BAJA-HA-HA!
- Leg IV** - Cabo San Lucas to Puerto Vallarta

### Sailing Instruction

Offering all levels from Beginning Sailing to Advanced Racing and Offshore Cruising, J World is the top rated school in America.

### Adventure Sailing Opportunities

Cruise the West Coast; join the Baja-Ha-Ha; race in the Banderas Bay Regatta or Transpac!

### Private Instruction and Coaching

World class staff with immense sailing, cruising, and racing experience.

### Also Offering...

- Corporate Events & Teambuilding
- Skippered and Bareboat Charters

J World has been providing exceptional sailing instruction, adventures, and charters for over 25 years.

Alameda - San Francisco - Puerto Vallarta



800-910-1101 www.sailing-jworld.com

## LETTERS

port. Class B AIS units with transponders are available all over the world — except the United States. Class A units, which all have receivers and transponders, sell for as little as \$ 2,400.

### ↑↓ MORE AIS OPTIONS AT WEST MARINE

Our Wylie 65 *Convergence* is in Australia where we're having a Class B AIS transmit and receive unit installed. We're looking forward to checking it out in October when we resume cruising, sailing from Brisbane to the Whitsundays.

During our approach to Brisbane last October, we crossed wakes with five ships in daylight. We had to alter course, but had no problems. But we did turn on the radar to get the course and speed of the ships and make sure there wouldn't be any close encounters. AIS should provide another level of security, especially at night. Of course, the most important thing is that the watchstander be fully alert and aware of the vessels, reefs, islands and other hazards in the vicinity.

I can also tell you that West Marine will be adding to our lineup of AIS offerings in the near future.

Randy Repass  
*Convergence*, Wylie 65  
Santa Cruz

*Readers — Randy Repass is the founder of West Marine Products, and now spends part of the year on the water testing the products that West Marine sells.*

### ↑↓ AIS FOR JUST \$150

I've had an AIS receiver unit installed and interfaced with my Nobeltec Visual Navigation software for almost three years on my Brickyard Cove-based *LaCoste 42 Favonius*. I purchased the AIS unit by mail from the U.K. for \$150 — more for the curiosity factor than anything else. But it's been more beneficial than I thought it would be for watching for the ferry traffic that seems to be zipping across the Bay all the time. While the ferry captains are trying to maintain a good lookout from the bridge, they are often traveling at 30 knots or more — according to my AIS — so you want to stay clear out of their way. The ability to see the name of the tug shooting up the Richmond Channel and into the Bay makes it far easier to call them on the radio to be sure they see you.

I have noticed that not all commercial ships are good about changing their status on the AIS. Often times they are in a designated anchorage in the Bay and reporting on the AIS status that they are 'underway'.

By the way, I installed a separate VHF antenna and cable on my radar arch for the AIS. But when I first tested the AIS, I used the masthead antenna. Wow, what a huge difference it makes in AIS reception to have the antenna 60 feet higher in the air! Using the masthead antenna, I saw the ships lining up at the sea buoys at the entrance to the ship channel five miles out, the ferry leaving the dock in Vallejo — both while sitting at my berth in Brickyard Cove!

I think that AIS will prove to be an even more worthwhile tool for the bluewater sailor. I hope to someday get out of the Gate again and turn left for a few thousand miles to find out.

Michael Pordes  
*Favonius*, *LaCoste 42*  
Richmond

### ↑↓ AIS IS PARTICULARLY HELPFUL AT NIGHT

Hello from jolly Brighton, England!

We installed a Raymarine Class B AIS receiver only two weeks ago in Sweden, and found it to be a fantastic tool for staying out of the way of ships while recently crossing the



**EASOM**

# ***Rigging for Champions!***



**White Dove 2008 IRC Champion**

**"I've worked with lots of riggers, and Easom Rigging is the only one who simply gets it right!"  
Mike Garl, owner**



***Sleeping Dragon*  
Winner Pacific Cup  
Class D and 2nd Overall.  
Dean Daniels, owner**



***Shaman Cal 40*  
Winner Pacific Cup Class A.  
Steve Waterloo, owner**

Easom Rigging has won more local, national, North American and world championships than all other Bay Area riggers combined!

**On-Site at 2008  
Big Boat Series  
CALL TO WIN!**



**Easom Racing and Rigging**

1150 Brickyard Cove Rd. Suite B1  
Point Richmond, CA 94801

**(510) 232-SAIL (7245)**



- Super efficient
- High reliability
- Worldwide sales and support



We have a watermaker to fit any need, from 150 to 1000 gallons a day.

#### WEST COAST DEALERS

**Emerald Harbor Marine, Inc.**  
Seattle, WA 98199  
Tel: 206-285-3632  
[www.emeraldharbormarine.com](http://www.emeraldharbormarine.com)

**Svendsen's Boat Works**  
Alameda, CA 94501  
Tel: 510-521-8454  
[www.svendsens.com](http://www.svendsens.com)

**Channel Coast Marine**  
Oxnard, CA 93030  
Tel: 805-985-0220  
[www.channelcoastmarine.com](http://www.channelcoastmarine.com)

**Outbound Yacht Services, Inc.**  
Dana Point, CA 92629  
Tel: 949-488-0652  
[www.outboundyachtservices.com](http://www.outboundyachtservices.com)

**Daily Marine**  
San Diego, CA 92106  
Tel: 619-222-9613  
[dailymar@aol.com](mailto:dailymar@aol.com)



*Your Dream, Realized.*

Spectra Watermakers • Tel: 415-526-2780  
[www.spectrawatermakers.com](http://www.spectrawatermakers.com)

## LETTERS

North Sea from Germany to Holland and England. When I checked the overall list of AIS targets, many times it was at the unit's maximum of 100 vessels. But overall, it really made



COURTESY MAHINA TIARE

**Amanda Swan-Neal and John Neal are AIS converts.**

things easier — particularly at night — figuring out where ships were headed and what the best way would be for us to alter course. The only downside is that fishing boats are not required to have AIS, and every now and then a target would show up on the radar but not the AIS. We quickly learned that

these targets were either fishing boats or sailboats.

We tried to have a True Heading (Swedish-built) AIS receiver and transponder installed before we left the boatyard in Sweden, but incompatibility issues and a possible defective diplexer — plus the impending four-week vacations by the boatyard and the AIS manufacturer — stymied us. We're sure looking forward to being able to transpond on AIS as well as receive.

P.S. We're soon off to Falmouth, England, then south to Spain and Portugal.

John Neal & Amanda Swan Neal  
Mahina Tiare, Hallberg-Rassy 46  
The Oceans of the World

### MANDATORY AIS FOR 20-KNOT BOATS

We purchased a Class B receive-only AIS unit from Milltech for \$200. It came in the form of a little black box with connections. Dan hooked the unit up to our Raymarine C-series system. The unit also requires a separate VHF antenna. We already had an extra coax cable running up the mast, so it was an easy installation. Fortunately, we'd kept the switch for going back and forth between the antennas. After digging it out of the parts box, we reinstalled it for the two antennas — one for VHF radio, one for the AIS — atop our mast. Even if we have the switch on the AIS side, we can still receive VHF radio transmissions. But if we want to transmit on VHF, we have to flick the switch to change antennas.

When you put the cursor on the image of a ship in the Raymarine screen, it activates an information sequence in the radar unit for the particular ship. When our screen receives that information, we learn all kinds of helpful stuff: the name of ship, where it's headed, and much, much more. But what we look for first, of course, is the 'closest point of approach' and the 'time of closest approach'. Our comfort zone with ships is two miles. We don't change course for ones that won't come closer than that, but we do monitor them visually and electronically.

What's great about the AIS information — especially at night — is that it allows you to change course very early to avoid a ship getting close to us. For example, one night we picked up a ship 15 miles away that was going to come within a quarter mile of us. But with our AIS providing such an early warning, we were able to change course for 10 or 15 minutes, then resume our original course. This left the 'closest point of approach' at an acceptable three-quarters of a mile. That alone made AIS worth it to us, as our radar wouldn't have picked up the ship that far away.

But here's an example of the beauty of having both AIS and



# Why settle?



## **Ballena Isle Marina**

Alameda 510.523.5528

## **Jack London Marina**

Oakland 510.834.4591

## **Treasure Island Marina**

San Francisco 415.981.2416

## **Martinez Marina**

Martinez 925.313.0942

You don't settle for less, why do it with your marina? Join one Almar marina and gain access to seven Bay Area marinas. Almar's reciprocal program takes the hassle out of your boating weekend. A simple call to the marina office and you can spend the weekend at Jack London Square or Treasure Island. Maybe a trip to a few of Almar's seven Southern California marinas. We make it so easy you may find yourself using your boat.

Almar boaters receive a 10% discount on any fuel purchase at Jack London Square and Ballena Isle Marina. Jack London Square Marina has just upgraded it's fuel dock with high speed fuel dispensers and now has the fastest pumps in the Bay Area. You don't have to settle anymore.

Almar is the largest operator of saltwater marinas in the country. Almar Marinas provide a wide range of services and programs that few marinas or yacht clubs offer. Some of these programs include: monthly boating seminars, boat handling classes, navigation courses and organized outings to local anchorages. Each marina offers wireless high speed internet access, which can be used with your reciprocal privileges at any Almar Marina. To see the difference, visit one of our marinas this weekend.



# almar.com

# Seawear<sup>tm</sup>

Nautical and Celtic Jewelry



Summer 2008

[info@seawear.com](mailto:info@seawear.com)

[www.seawear.com](http://www.seawear.com)

## LETTERS

radar. One night I had two ships coming in opposite directions on our starboard side. They were going to meet about half a mile from us. In addition, we had a storm cell on our port bow that we wanted to avoid because it had lightning. So I found myself in a squeeze situation, with a ship coming up our rear, one coming down on our nose, and a storm cell blocking our best escape route. I ended up making a 90-degree turn and just getting the heck of there, letting the ships come at each other without involving us at all, and letting the storm cell pass to our starboard. The good information from both the AIS and the radar allowed us to take early action and stay out of trouble.

We love our Class B receive-only unit, but we don't think recreational boats need transmitting capability. Let's leave the transponders to just the big boys so our screens aren't cluttered with too much information. Ships are fast and dangerous to small boats, but small boats move so slowly there are rarely collisions, so that's not an issue. On the other hand, we think it should be mandatory that all vessels capable of doing 20 knots have AIS units with transponders. Plus, even the Class B receivers should be equipped with a feature that sounds an alarm when a bogie is moving faster than 20 knots.

Reylyn & Dan Cox  
*Tropical Dance*, Gulfstar 50  
San Clemente

### ⇕NO WONDER U.S. CRUISING BOATS DON'T HAVE THEM

I just read your updated *Lectronic* piece on AIS units, explaining that you can't get Class B AIS units with transmitters because the FCC hasn't approved their transponders yet. No wonder there are no U.S. cruising boats here in the South Pacific with Class B transponders.

However, a surprising number of European cruising boats — and nearly every professionally crewed boat — out here is equipped with Class B AIS units with transponders. I'm told most paid less than \$500 U.S. for them. One popular unit seems to be the True Heading CTRX Class B transponder, although looking on the internet they are listed for 650 euros — or about \$1,000 U.S. The power consumption averages six watts — half an amp at 12 volts.

Wayne Meretsky  
*Moonduster*, S&S 47  
South Pacific / Alameda

*Readers — We'll have more on AIS units in Sightings and in next month's Letters.*

### ⇕IT'S HAMMER TIME

From '69 to '71, I taught ship stability at the U.S. Navy West Coast School's Command on Treasure Island. Although it was almost 40 years ago, I think I still remember the basic theory. And I think Lee Helm's statements in the May issue may be a little misleading to your readers.

She says, "A heavy boat with the same waterline shape would heel over just as easily as a light one." I think that the erroneous conclusion some readers might reach is that weight is not that important. The amount of weight added to a boat, and the distance from the center of gravity, is very important in determining the effect on transverse stability.

Adding weight below the center of gravity will increase the righting arm. Adding weight above the center of gravity will decrease the righting arm. The amount of shift in the center of gravity is a function of total displacement. So adding the 100 pounds five feet above the center of gravity on a 200-pound



In Northern California



314 Tideway Dr., Alameda, CA 94501  
www.helmsyacht.com  
(510) 865-2511

In Southern California  
**West Coast Multihulls**  
1053 Rosecrans, San Diego, CA 92106  
www.westcoastmultihulls.com  
kurt@westcoastmultihulls.com  
(619) 571-3513

# SEAWIND



**SEAWIND 1000XL**

Come see the new Seawinds at:  
Newport Boat Show September 11-14  
Annapolis Boat Show October 9-13

## HELMS YACHT SALES

## WEST COAST MULTIHULLS



**SEAWIND 1160, 2007**

Like new, well maintained, fun to sail. Blue water cruiser from Australia's premier builder. Current back orders for 1160 can take months. You can be sailing down Baja in a few weeks. Call Gary at (510) 865-2511. \$459,000



**CORSAIR 36, 2003.** Cruise Mexico in the winter and Tahoe in the summer. Comes with a trailer. Often sailed at 20 knots, yet comfortably fitted out with 3 double and 1 single berths. Also has a full galley, 2 showers and all the amenities Call Gary (510) 865-2511. \$196,000



**2007 SHUTTLEWORTH 47 PERFORMANCE CRUISER**

Currently in Hawaii, this boat is loaded, equipped, and ready to sail the So. Pacific. Truly a complete cruiser ready to sail the world. Including dive gear and compressor. For more info, visit our web site: helmsyacht.com. Call Gary at (510) 865-2511. \$950,000



**NEW!**

**WEST COAST MULTIHULLS  
NEW DEALERS  
FOR PDQ  
POWER  
CRUISING  
CATAMARANS**



**2002 PDQ 34 POWER CATAMARAN**  
This rare West Coast economical coastal cruiser is well equipped and ready to go. 14 knots cruise at 4 gallons per hour fuel burn is as good as it gets, plus more room than most 38 footers! For more info and specs call or email Kurt (619) 571-3513.



**32' PDQ CRUISING CATAMARAN, 1996**  
Lots of Canadian quality built into this proven design. All the right stuff and **READY FOR MEXICO!** Asking \$109,000. Owner motivated, make offer. Call Kurt (619) 571-3513.



## YOUR BOAT DESERVES IT!

Polishing • Detailing  
Maintenance  
Bilge Cleaning  
Washdown  
Carpet and Cushion  
Cleaning

Ask your Harbormaster!  
Fully Insured & Marina Approved

"Seashine does an incredible job on our  
new Hunters, Jeanneaus and brokerage  
sailboats – they have impeccable  
service and reliable quality."  
– Don Durant, *Cruising Yachts*

Serving the Bay Area Since 1986

Call now for a  
Free Estimate

510 428-2522 or 415 457-6300  
www.seashine.net

## LETTERS

boat will have a greater negative effect on stability than adding 100 pounds five feet above the center of gravity on a 100-ton ship!

I am sure Lee that will correct me if I wrong.

David Hammer  
Weaverville

David — We asked Lee herself for a response.

"You're not wrong, but you're answering a slightly different question.

"I keep running into people who think heavy boats are more stable just because they're heavier. They believe that increased stability justifies loading up with extra cruising gear, or contributors to the seaworthiness of their heavy-displacement crab-crushers. There is a misconception that adding weight — even adding weight that doesn't change the height of the center of gravity — will increase righting moment. But recall the formula for metacentric height: Transverse moment of inertia of the waterplane divided by displacement. When displacement goes up, metacentric height goes down. Righting moment is proportional to displacement times heel angle times the distance of the metacenter above the center of gravity. All other things being equal, it's generally a wash for righting moment when weight is added to a cruising sailboat, because the drop in metacenter cancels out the increase in the displacement term.

"Max didn't seem to get cognitive purchase on this one either, but like, I'm sure you have the chops to follow the math, even without the diagram."

### ↑↓IT ALMOST SEEMS LIKE A NEW SPORT

ERIC SIMONSON / WWW.H20SHOTS.COM



Sailing, 'flailing' — neither seems to completely capture what's going on with these 18-ft skiffs.

to need a different name. Perhaps 'Flailing'?

That was a nice photo of an 18-ft skiff in the August 11 'Lectronic. She isn't exactly flying — but almost. And she's not sailing, at least not the way most of us experience it. What she's doing seems

Steve Richard  
Kanalu, Catalina 34

### ↑↓EXERCISE AND ECOLOGY

It seems as though there are plenty of activities for maintaining upper body strength while cruising. But what about for the lower body and cardio? My solution would be a pedal-driven system that could also help charge the boat's batteries. It would be green, have a low carbon footprint, and offer aerobic workouts. Does any such thing exist?

Reggie Good  
Knot Ready, Cal T/2  
Submit, Cal Cruising 36  
Lakeside, MT

Reggie — We know of a number of people who carry small 'stair climbers' on boats, but none that are hooked up to the charging systems. But we think somebody should invent one. They'd not only be useful on boats, but also in high schools,



# DESTINATION MARINA BAY

*Ask about our Fabulous  
Fall 40-Footer Special!  
Limited availability – call today.*

*On the Richmond Riviera.*

*Come discover a sunnier,  
warmer East Bay marina.*

*Marina Bay is the sunshine leader!  
Call to give us a try.*

LONG TERM TENANTS ENJOY:

- Deep draft harbor (race boat friendly)
- Berth to Bay in 15 minutes
- Nearby village of Point Richmond
- Onsite deli & restaurant



**MARINA  
BAY  
YACHT  
HARBOR**

*A Certified Clean Marina*



[www.MarinaBayYachtHarbor.com](http://www.MarinaBayYachtHarbor.com)

1340 Marina Way South, Richmond, CA 94804

**(510) 236-1013**



You do the Sailing  
WE DO THE REST



Join SailTime today and exclusively sail a brand new Hunter sailboat a minimum of 7 times a month

- Sail a new Hunter just like you own it
- Guaranteed minimum 7 sailtimes per month
- Unlimited 'as available' usage
- Easy online scheduling
- All inclusive monthly fee
- Electronic check-on/check-off
- Sailing instruction available
- No long-term commitments

**NOW 3 BAY HOMEPORTS!**  
Sausalito  
San Francisco  
Emeryville

Call 877-SAILTIME today to discover more

...when all you want to do is sail!

California Channel Islands Monterey  
Newport Beach San Diego San Francisco

and further SailTime bases Worldwide

[www.sailtime.com](http://www.sailtime.com)

## LETTERS

where students expend so much energy but have very little to show for it.

### ↑↓THE LIGHTEST, FASTEST, CENTER-COCKPIT, AFT-CABIN SLOOP UNDER 50 FEET THAT WAS EVER MADE

In your July *Loose Lips*, you ran a segment on the late Alameda naval architect Carl Schumacher. In addition to the boats you listed, he also designed a line for Oyster Yachts. Yes, the very successful Oyster brand in England.

Schumacher designed the Oyster Lightwave 48, and 20 hulls were built in the late '80s. Mine was hull #2, named *Chant Pagan*. Based on my research at the time I purchased her used, the Lightwave 48 was the fastest, lightest, center-cockpit, aft-stateroom sloop under 50 feet that was ever made. It is six seconds/mile faster than the Swan 46, but much larger inside. *Scarlett O'Hara*, a Lightwave sistership to my boat, won her class in the Fastnet again this year.

We sailed our Lightwave across the Atlantic in the '04 ARC, where we rated mid-fleet at 113 out of 22 boats. We finished in St. Lucia 16.5 days later, the 27th boat to finish.

We bought our Lightwave 48 in England for \$220,000 in '02, and sold her three months ago for \$200,000.

Capt. Steve Woodruff  
Boatless  
Dana Point

### ↑↓THREE RECOMMENDED FIXES FOR THE ICOM 802

Someone told us to check out your website for issues concerning the ICOM 802 SSB radio. You've got a lot of stuff on the site, but I haven't been able to find out much about the 802. In any event, we've heard that we have to have a clipping issue taken care of, and that we'd also want to have an output limiter overridden. Can you help?

Bill & Diane Stevens  
Argonaut, Brewer 45  
New York, NY

*Bill and Diane — Some ICOM 802s had problems with clipping, and eventually the company came up with a free fix. Alas, it's one that requires you to ship your radio back to the factory. Visit their website at [www.icomamerica.com](http://www.icomamerica.com) for instructions on how to do so.*

*Some other SSB radio experts believe that the ICOM 802 unnecessarily limits its power output. If ICOM won't make this software fix for you at the factory, other qualified technicians can and will. While they are at it, we recommend that you have the new ICOM package of channelized frequencies downloaded onto your radio, which will result in your Channel 73, for example, being the same frequency as the one on almost everybody else's Channel 73.*

*We had all three fixes made to our 802 and have been very satisfied with the results.*

*By the way, our Idiot's Guide to SSB Radio article was such a big hit last year — even SSB and ham experts have requested reprints for handing out — that we've run it again in this issue.*

### ↑↓AVERAGE WIND SPEEDS SEEM TO BE ON THE RISE

I have a theory that the average wind speeds on the San Francisco Bay are on the rise. I've been sailing the Bay for the past 24 years, and over the last two years it has been much windier than usual. Could it just be that the ebb and flow of water temperatures are causing it? Or, in a small way, could it be because of global warming?

San Francisco Bay winds are created by a very cold ocean





**West Marine®**  
**Rigging Service**

# Now's the time for a **Tune-Up!**

Take advantage of the off-season to have our experienced staff design the ultimate package to optimize the performance and look of your boat. Custom rigging is available through any West Marine store location.



- **Installation Available**
- **Running Rigging**
- **Standing Rigging**
- **Dock & Anchor Lines**
- **Lifelines**

**Contact us at 888-447-RIGG, or visit our  
 Onsite Rigging Locations in:**

**Alameda**

730 Buena Vista Ave.  
 (510) 521-4865

**San Diego**

1250 Rosecrans St.  
 (619) 255-8844

**Seattle**

1000 Mercer St.  
 (206) 292-8663



RONSTAN • WICHARD

# Rolex Big Boat Series September 11-14, 2008

## RACE READY RIGGING SUPPORT

PROFURL • SCHAEFER



LEWMAR • NAVTEC • YALE CORDAGE • SPARCRAFT • SPINLOCK



*On location all week  
at the  
St. Francis YC*

- Winch Service and Spares
- Hydraulic Service and Seals
- Full Inventory of Cordage and Shackles
- Splicing Available
- Emergency Rigging Services



2540 SHELTER ISLAND DR., STE. E  
SAN DIEGO, CA 92106

PHONE: 619-223-3788

FAX: 619-223-3099

WWW.RIGWORKS.COM

JOHNSON • ANTAL • FACNOR • TYLASKA • FREDERIKSEN

## LETTERS

and a very hot Central Valley. As the wind travels down from the northwest, it causes an upwelling of cold water from the deep. As the sun shines hot on the valley, the hot air rises. Think of wind like a stream of water. As the hot air rises, the cold air rushes in to take its place. The bigger the difference in temperature between the two, the higher the wind speed on the Bay.

Then there are the gaps in the coastal mountains at the Gate and at other valleys, which funnel the wind, causing the windspeed to increase. If you've ever sailed in The Slot on a typical summer day, you know about funnels.

So my theory is that as a result of higher temps in the valley over the last few years, the windspeed on the Bay has increased. Usually we have wind between 20 to 25 knots every day from about May to September, but lately it's been blowing 30 to 35 knots every day. Yesterday it topped out at 36 knots at Angel Island.

I'm just a sailor, and I don't have any real data to back up my theory, but I would love to hear from any other Bay Area sailors who have noticed this.

Craig Russell  
Addiction, Newport 30 MKIII  
Emeryville

*Craig — Just before we received your letter, we were talking with Associate Publisher John Arndt, who was bemoaning the fact that "there's hardly been any wind for the Corinthian YC beer can races this year." And if you look at the June 18 'Electronic, there's a photo feature about how warm and light the winds have been on the Bay this year. So when it comes to anecdotal evidence for your hypothesis, the data would seem to be conflicting.*

*Trying to make sense of the weather is complicated to the nth degree. There are so many interacting factors — around the globe and even as far away as the sun — that even the most powerful supercomputers can't make very accurate weather forecasts beyond three days. So we'd be slow to jump to conclusions based on scant and anecdotal local evidence. For if you don't, you'll have to deal with folks who jokingly claim we're really undergoing global cooling based on the fact it was unusually cool in Mexico last winter.*

### ↑↓ I JUST LIKE TO HELP SEAFARERS

In the April '08 *Changes* there was an article by Gary Barnett of *Gallant Fox* that included some inaccurate information about a situation in which Ken Douglas of the Pearson 365 *Mermaid* almost lost his finger. The following is — in Ken's own words — what happened:

"I singlehand the Pearson 365 ketch *Mermaid*, and in February of last year I was stupid enough to check the V-drive with my hand. For all practical purposes, the end of one of my fingers was severed. Fortunately, I had a guest aboard who helped me reposition the end of the finger and stop the bleeding. I then got on VHF 22 and asked if anybody in San Blas knew if there were any medical facilities. A cruiser anchored in the bay came back and advised me that there was such a facility. Then Jama, also known as Norm Goldie, came up and took over. He contacted Ishmael, the fellow who has the restaurant on the beach and who provides various cruiser services. So when I drove my dinghy onto the beach, Ishmael was waiting to drive me to the Naval Hospital which, thanks to Norm Goldie, was expecting me and knew the nature of my problem. Four hours after my initial call, the end of my finger had been reattached. I was told if it turned black, it was going to have to be cut off. The whole cost was just \$7



# Choosing a bottom paint just got easier!

*You can pick old technology...*



## *...or Micron® Technology.*

***A compass works, a GPS works better. Old bottom paint works, Micron Extra works better!***

Unlike traditional high copper bottom paint, Micron Extra is engineered for California. It uses less copper more efficiently, providing many seasons of hassle free boating.

Micron Technology is a controlled polishing breakthrough that delivers a smoother more fuel efficient surface and the long-lasting antifouling protection that you expect.

Old technology bottom paints continue to build up and crater over time, but there is no build up with Micron Extra, so you will never spend money to remove it.

If you are not using Micron Technology, you are using old technology. It is that simple.

**Do yourself, your boat, and the environment a favor, choose Micron Extra.**



Our World is Water

Visit our website for more information: [yachtpaint.com](http://yachtpaint.com)

 Interlux®, Micron® and Biolux® are registered trademarks of Akzo Nobel.

# LETTERS

U.S., including medication. I thank the sea spirits that Norm was in San Blas and had the connections to set this all up, for today my finger works normally, and other than an ugly fingernail, looks great. As far as I'm concerned, Norm saved my finger."

I just want cruisers to know the facts, which are that many years ago I was asked by the Port Captain's Office and Mexican Immigration to help cruisers in any way that I was able. I've been doing this for 42 years — not just the 30 as mentioned by Barnett. I help to the best of my ability and without a salary or receiving commissions. When I get on the radio, I ask cruisers if I can help them, I don't force myself on them.

And I have never said that I was the 'king of San Blas', nor would I like to be called that. Not on your life. I'm just a guy who likes to help seafaring newcomers enjoy a beautiful little fishing village. Over the years, my wife Jan and I have assisted over 4,000 vessels who have come from all over the world to visit San Blas, and we will continue to do so.

Barnett also claimed that cruisers can check in with the port captain's office by VHF. There are lots of people who work in that office, so I don't know who told him that. But I can assure everyone that the Assistant Port Captain has told me repeatedly that he wants cruisers to stop by his office and fill out two short forms. The problem with checking in by radio is nobody speaks English in the port captain's office and few cruisers speak Spanish well enough to be understood. It only takes about 10 minutes to fill out the forms, and there is no charge.

Norm Goldie  
San Blas

*Readers — Clearing between domestic ports in Mexico is, oh, about 10 times less hassle and less expensive than it was only a few years ago. And the rules are inconsistently enforced.*



LATITUDE / RICHARD

*Under the law, cruisers are supposed to check in with the port captain every time they arrive in a new port captain district. Checking in is a very short process, there is no charge, and it's not like you have to do it the second you arrive. While some port captains are very casual about boats checking in, others take it seriously. So whenever you arrive at a new port captain's district, make sure you find out what the port captain in that area wants, then comply.*

**Love him or not, Norm Goldie has helped hundreds of cruisers in San Blas.**

*As for Norm Goldie, there is no doubt that he's helped many cruisers over the years in San Blas. But neither is there any doubt that he's driven a large number of cruisers a little crazy, too. He's sort of like the Hillary Rodham Clinton of San Blas — a polarizing figure.*

## ⇅ DIRECT TO DVD

We did the Ha-Ha last year and loved it. We're going to do it again this year, but with our 10- and 11-year-old kids as we start our extended cruise.

If there wouldn't be any objection on the part of the Ha-Ha folks, we'd like to make a DVD of the event. We'd try to include

**ATTENTION CRUISERS! MEXICAN LIABILITY INSURANCE ONLINE**

**MARINERS**  
GENERAL INSURANCE GROUP

Now with six offices offering you local insurance service and global insurance coverage.

**SEATTLE**  
Joe Cable  
(800) 823-2798 • (206) 281-8144  
Fax (206) 281-8036

**NO. CALIFORNIA**  
(800) 853-6504 • (650) 373-0595  
Fax (650) 548-1585  
email: boomeins@aol.com  
Lic. # 0A99058

**L.A./ORANGE COUNTY**  
Craig Chamberlain  
(800) 992-4443 • (949) 642-5174  
Fax (949) 642-0252  
Lic. # 0D36887

**SAN DIEGO**  
Henry Medina  
(800) 639-0002  
Fax (619) 226-6410  
Lic. # 0A96346

**BRADENTON, FLORIDA**  
Jerry Norman  
(800) 914-9928  
Lic. # E051940

**New!**  
**PUERTO VALLARTA**  
(949) 274-4111

*We insure racers and cruisers all over the world with prompt, reliable service.*  
**www.marinersinsurance.com**

**ASK ABOUT OUR NEW RACING SAILBOAT PROGRAM!**

**It's a Mariner's Fact:**  
Mariner's General Insurance insures cruising sailboats all over the world... are you heading out?





CALL FOR  
COUNTER-  
SEASON SPECIALS!

# Yacht at Rest, Mind at Ease

WWW.YACHT-TRANSPORT.COM • 1-866-SHIP-DYT



◆ SAFEST WAY TO SHIP ◆ PREMIER SERVICE FOR ANY YACHT ◆ RELIABLE FREQUENT SCHEDULES ◆ UNIQUE DESTINATIONS ◆ COMPETITIVE RATES

◆ SAFEST WAY TO SHIP ◆ UNIQUE DESTINATIONS ◆ RELIABLE FREQUENT SCHEDULES ◆ SAFEST WAY TO SHIP ◆ UNIQUE DESTINATIONS ◆ COMPETITIVE RATES ◆ PREMIER SERVICE FOR ANY YACHT



WORLD CLASS YACHT LOGISTICS

**Dockwise Yacht Transport USA**

Telephone +1 954 525 8707

E-mail: [dyt.usa@dockwise-yt.com](mailto:dyt.usa@dockwise-yt.com)

**Dockwise Yacht Transport Europe**

Telephone +39 [0]10 278 9411

E-mail: [dyt.europe@dockwise-yt.com](mailto:dyt.europe@dockwise-yt.com)

**Dockwise Yacht Transport France**

Telephone +33 493 931 856

E-mail: [dyt.france@dockwise-yt.com](mailto:dyt.france@dockwise-yt.com)

*one design  
offshore spec  
multihulls  
classic sails*

**NEILPRYDESAILS**

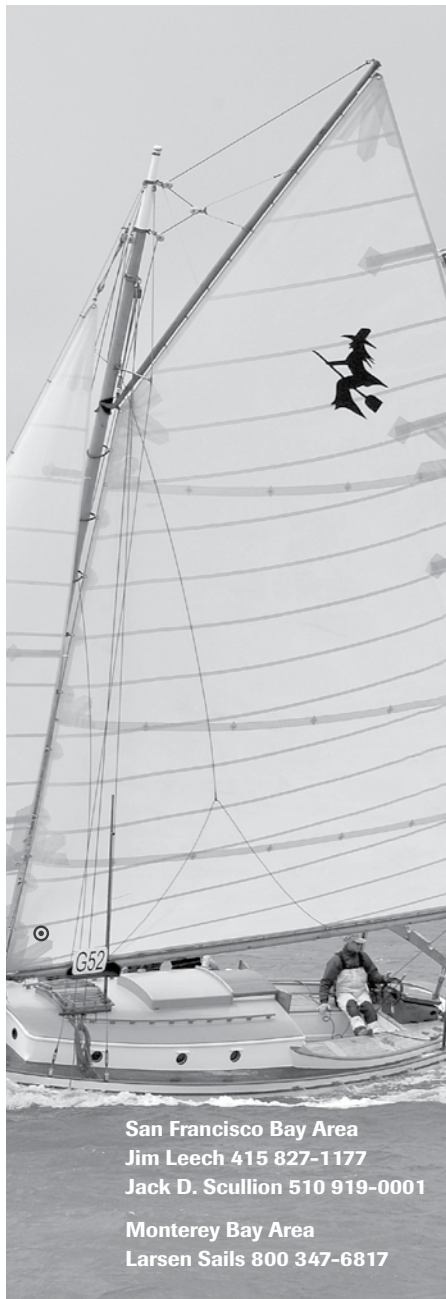

San Francisco Bay Area  
Jim Leech 415 827-1177  
Jack D. Scullion 510 919-0001

Monterey Bay Area  
Larsen Sails 800 347-6817

*Sail outside the box*  
[www.neilprydesails.com](http://www.neilprydesails.com)

PHOTO: L38

## LETTERS

everything from the Halloween Costume Kick-Off Party, to the actual sailing, to the activities and parties in Turtle Bay and



LATITUDE / RICHARD

Bahia Santa Maria, as well as interviews with the participants. The Ha-Ha lends itself perfectly to such coverage.

*The Borens on 'Third Day' in last year's Ha-Ha.*

Because we can't be everywhere during the event, we'd also encourage other participants to submit some of their video and still shots for inclusion in the DVD. And once the DVD was edited, we'd like to try to sell them in order to help finance our cruise and fund some of the aid work we plan to do during our five-year cruise. What do you think?

Richard Boren  
Third Day, Pearson 365 ketch  
Bakersfield

Richard Boren  
Third Day, Pearson 365 ketch  
Bakersfield

*Richard — It's nice for you to say such good things about the Ha-Ha, and to care what we think about your proposed DVD. Like you, we've always thought a DVD of the event would be terrific. We have videos for most of the Antigua Sailing Weeks we did back in the '80 and '90s, and they are some of our most prized possessions. Unfortunately, we've never had the time to both run the Ha-Ha and document it on video. So, sure, speaking as the owner of the Ha-Ha once again, go ahead and make a DVD. We're not going to say it's the 'official' Ha-Ha DVD, at least not until we see it, but we'll be happy to let other folks know what you have planned. And if they want to contribute, that sounds like a great idea, too.*

### ↑↓DON'T FORGET TO TIP

It's not that long before this year's class of cruisers set sail for Mexico, so we thought it would be timely to remind folks about Temporary Import Permits or TIPs. Cruisers should get their TIP at their first port of entry in Mexico, which for most folks will be Ensenada or Cabo.

When getting a TIP, cruisers will have the opportunity to list all their important gear — engines, electronics, computers, and other valuables. We encourage people to do this, carefully noting the make, model and serial number of each. You may even be able to attach a prepared list of this information to the TIP along with an official stamp.

Why list all this valuable equipment on the TIP? If you need to take anything back to the States for repair, or replace them, it should be much easier to do if they are listed on the TIP.

Yes, we expect there will be numerous responses about how it's not necessary to do all this, that this person and that have never been asked to pay duty when bringing stuff into Mexico. But we say that having it all listed at least makes it official in the eyes of Customs in Mexico.

We're currently in Santa Rosalia while we wait for our Icom radio to be repaired and returned from the States.

Chuck Houlihan & Linda Edeiken  
Jacaranda, Allied 39  
San Diego / Santa Rosalia





La Paz, Baja California Sur, Mexico

DISCOVER THE FINEST MARINA IN BAJA WITHIN A LUXURIOUS RESORT SETTING.



# MARINA COSTABAJA

is located only minutes from downtown La Paz and offers the closest access in Baja to the World Heritage Site islands on the Sea of Cortez. Phase II neighborhoods are currently under construction, including Las Colinas Hillside Homes alongside the golf course and the luxurious VistaMar Residences and Casitas. Both afford homeowners sweeping water views and the opportunity to live with the marina and first-class resort amenities right in their own backyard.

The safe and protected double-basin marina features 250 slips from 30 to 200 feet, ready to accommodate vessels up to 220 feet. Built-in pump out stations, as well as TV and internet access are available at each dock, along with 24-hour security and a complete suite of TBC (Total Boat Care) services from the professional, customer satisfaction-focused staff.

Enjoy the Moorings Yacht Charters and the surrounding marina village, lined with colorful shops and restaurants, offering groceries, boat rentals and charter services for diving and fishing expeditions. Take advantage of the shuttle service to and from La Paz or access the 120-room resort hotel with its swimming pool, fitness room and restaurant.

Reserve your slip for winter now at Marina CostaBaja.

- Full Ownership Luxury Homes
  - Marina CostaBaja
- Pueblo Marinero (Marina Village)
  - CostaBaja Beach Club
  - Trail System
  - Espiritu Spa\*
- Gary Player Design Golf Course\*\*

\* future amenities  
\*\* spring 2010

Homes from the \$400s to over \$1.5 Million

VISTAMAR RESIDENCES



Contact Gabriel Ley (Marina Manager) info@costabajaresort.com 011 52 (612) 121-6225 www.marinacostabaja.com

CALL FOR '08/09  
RESERVATIONS  
LARGE SLIPS '08,  
AVAILABLE FALL '08,  
SMALLER SPRING '09



MARINA NUEVO VALLARTA  
*Bahía de Banderas, Nayarit*



TO MEET INTERNATIONAL EXCELLENCE MARINA SERVICES WE ARE BUILDING 230 NEW MOORING SPACES IN 6 DOCKS WITH SLIPS RANGING FROM 22' TO 130' LONG WITH WATER, ELECTRICITY, CONTROLLED ACCESS GATES TO THE DOCKS, FIRE FIGHTING SYSTEM, WASTE DISPOSAL, PERISTALTIC PUMPS, 24/7 SURVEILLANCE, FUEL DOCK, WIFI INTERNET, AND MUCH MORE!



**NOW UNDER CONSTRUCTION!**

FOR MORE INFORMATION:

PHONE: 52 (322) 2977000

MARINA COORDINATES:

LAT. 20°4'22"N LONG. 105°17'28"W

HARBOR MASTER: JUAN S. ESTRADA  
JUAN@MARINANUEVOVALLARTA.COM

MONITORING VHF 16



ASK FOR OUR LONG TERM LEASE PROGRAM  
ONLY A FEW AVAILABLE

WWW.MARINANUEVOVALLARTA.COM

## LETTERS

Readers — *TIPs* serve several purposes. Since you can't get a *TIP* unless you are a foreigner, they are a way for the Mexican government to be sure all nationals have paid duty on their boats in Mexico. For cruisers, they are the document that allows them to legally leave Mexico without their boats and, in theory at least, bring repaired or replaced gear back into Mexico without having to pay duty on it. Mexican Customs being what it is, you often can just bring stuff in without having it listed on your *TIP*, or you can have a *TIP* and still not be allowed to bring replaced or repaired stuff back into Mexico without paying duty. By having the stuff listed on your *TIP*, the odds greatly in your favor that you won't have to pay duty.

*TIPs* cost about \$50, are easy to get, and are necessary if you're going to be in Mexico for longer than your tourist visa.

### ↑↓ THE FLOATING BORDELLO IS STILL FOR SALE

The last I heard of actor Errol Flynn's 75-ft ketch *Sirocco* was last year when she was up for sale. She had been refurbished and was sailing under her original name of *Karenita*. Do



WEBB LOGG

you know what's happened to her? I think she ended up in Monaco or somewhere in the Med.

Pete  
From Down  
Under

**Now, if you've got a couple million lying around, you too can own a former floating bordello. Disclaimer: staff not included in purchase price.**

*Pete* — The ketch that was designed by John G. Alden and built by George Lawley and Son, and which was described as a "floating bordello" under Flynn's ownership, is still in the Med and still for sale. For a mere 1,500,000 euros — or about \$2,203,348 in what used to be called 'real money' — you could own her yourself.

### ↑↓ HOW LONG DOES IT TAKE TO SAIL TO COSTA RICA?

I've been reading *Latitude* a lot, and would really like to go on a long-term trip of my own. Can you tell me how much time it would take to sail a 40- to 45-ft catamaran from San Francisco to Costa Rica? I can't seem to find an answer for this anywhere online, and thought you'd be able to help more than anyone.

Genevieve Lacroix  
San Francisco

*Genevieve* — Thanks for having confidence in us. There are so many huge variables in a San Francisco to Costa Rica sailing trip that it's difficult to answer your question with precision. For instance, are you talking about a delivery kind of trip or a cruise? Will the motor be used in the light air that's bound to be encountered along the way in Mexico and Central America? Will you be sailing hard on a fast cat, or easy on one that's loaded down?

The distance between San Francisco and Costa Rica is roughly 2,800 miles. Given the large areas of light air, you might average as little as 100 miles or less a day if you don't motor at all. If you used the engine periodically and at the right times, you might average as much as 125 miles a day. So we'd figure on between 22 to 28 24-hour sailing days.

However, only delivery skippers would be crazy enough





The School of   
**SAILING & SEAMANSHIP**  
 | Orange Coast College



## Make Your First Ocean Passage a Great One

**Learn what it takes** to make a major cruise under sail during our 24th offshore sail training voyage. Our 2009 schedule offers opportunities for classic passages, shorter coastal trips and participation in long distance races.

Along with eight other crewmembers, you'll sail in all conditions, standing watches and steering as *Alaska Eagle* sails 180 to 240 miles a day. Our emphasis is on helping you build skills in an environment of fun and great sailing. Many who sail with us are planning voyages of their own. There is no better way to prepare.

### Newport Beach, CA – Cabo San Lucas, Mexico

March 6 - 13, 2009

*Alaska Eagle* will be the communications boat for the Newport – Cabo Race. Leaving before the start, *Alaska Eagle* will position herself amongst the fleet, keeping track of the racing boats. An overnight stop in Turtle Bay will be made to allow the back of the fleet to catch up. \$1695

### Cabo San Lucas, Mexico – Newport Beach, CA

March 17 – 25, 2009

Sailing the Baja coast can be a challenging mix of upwind sailing and motoring with plenty of navigational challenges. Depending on conditions, a stop or two may be made along the Baja Coast. \$1495

*Visit [occsailing.com](http://occsailing.com) for information on additional Alaska Eagle Ocean Passages*

### San Francisco, CA – Newport Beach, CA

April 19 – 26, 2009

*(after the Strictly Sail Boat Show)*

Sail under the Golden Gate Bridge and down the coast, stopping at a mixture of remote and popular anchorages. This leg will also offer US Sailing Coastal Passagemaking certification for those having the prerequisites. \$1695



**2009 SKIPPERS**  
Rich and Sheri Crowe

### *Sail and Learn with the Best*

Since Rich and Sheri Crowe sailed *Alaska Eagle* from England to California in 1982, they have been aboard as skipper and mate for the majority of her voyages. Their adventures have taken them north to Alaska, south to Antarctica and everywhere in between. They have so many offshore miles, we've lost count. In their spare time they've built three boats: a 54' aluminum adventure boat and two Farr 44s, virtually by themselves. Their most recent 'vacation voyage' was spent sailing their Farr 44 *Tabu* to Ecuador.

*Licenses held:* USCG Master Upon Oceans • STCW International Yacht Master (RYA/DOT) • US Sailing Instructor: Keelboat, Cruising, Coastal Navigation

To learn more: [www.occsailing.com](http://www.occsailing.com) To request a color catalog or specific info: **949-645-9412**  
 Or write: *Alaska Eagle Voyages*, 1801 W. Coast Hwy, Newport Beach, CA 92663

BEST IN CLASS - BACK TO BACK

# FLIGHT LINE™



Using the ultra-light, low-stretch Flight Line™, "Masquerade" won consecutive J/105 championships. Featuring a stronger-than-steel Dyneema® SK75 core and protective XLF cover, Flight Line™ is best in class for One-Design spinnaker sheets and control lines.

Ask for Flight Line™ at leading performance-rig shops.



NEW ENGLAND ROPES

Performance Guaranteed.

NEW ENGLAND ROPES, Corp., 848 Airport Road, Fall River, MA 02720  
T +1 508-678-8200, www.neropes.com

## LETTERS

*to make such a passage without stopping, and even most of them would stop at Turtle Bay, Cabo, Puerto Vallarta, Zihua, Huatulco, and El Salvador to catch some sleep, look around, and perhaps take on fuel. The average cruiser would take the better part of a winter season — November through March — to sail to Costa Rica, not wanting to miss the many cruising charms of Mexico.*

### ↑↓IT TURNED OUT NOT TO BE A GRAY 'RACING STRIPE'

Having just read the February article on duct tape, I have an off sailing anecdote that readers might enjoy. I was recently at a presentation in Monterey given by one of our foremost former astronauts, Capt.(ret) Dan Bursch. One of his slides showed him dressed out in complete space suit gear as he prepared to go out of the Space Station. A particularly observant member of the audience asked about a grey band on the astronaut's arm. Sure enough, it was duct tape! In this case it was being used to strap an extra meter to the astronaut's arm. Kind of redefines the old axiom, 'don't leave home without it'.

Mike Faulk

Gitana Azul, Pearson Electra  
Santa Cruz

### ↑↓DREAM CAT

Several years ago, I was going to sail my boat to St. Barth for the winter holidays to meet *Latitude's* catamaran *Profligate* and a group of other catamarans for some sailing fun. Alas, a shortly before I could my Leopard 47 cat was whacked by hurricane *Francis* in the Bahamas. After she was repaired, I sold her.

For the last few years, I have researched several catamaran manufacturers in hopes of eventually buying a new cat. Well, that day may not be that far off. So my question for *Latitude* is, if you had a large budget, what would your ultimate catamaran be?

Prior to owning the Leopard, I had a Fountaine-Pajot 42, which was a good starter cat. I'm not sure today's cats are as well-built. In any event, I'm looking for something in the 45- to 65-ft range that would have a huge 'wow factor', be fast under sail and power, have composite hulls, be safe, and handle well. Your opinion would be of a great help to me. So if I handed you a big check, which cat would you get?

G.K.  
Oregon

*G.K. — If you handed us a check with lots of zeros, we'd build Profligate all over again, but with carbon everything, a three foot longer J, fairer hulls, and better non-skid on the decks. We'd keep the systems almost as ultra simple because we like to sail more than we like to do maintenance and repairs. We'd continue to eschew luxurious stuff, because we think luxury is overrated. It's also heavy and makes cats lazy. Sixty-three feet is a larger cat than anybody really needs, but it's still small enough to singlehand — the most important quality in any boat — and we have to confess that we've grown fond of having as much deck space as some small countries. Because of her long waterline and relatively light weight, Profligate is plenty fast for us in everything but zephyrs. As you can tell, we love our cat, warts and all, so we can't imagine ever selling her.*

*While you could have a custom cat built, it's pretty risky business. Probably a third of the people we know who have done it have been less than happy with the experience. The other option is a production boat. You pretty much know what you'll be getting at what price, but you are limited to buying only what they have to offer. Except for the Gunboats, Outremers,*



# Harbor 25



## HARBOR 25

**Enjoy Sailing in Style and Comfort**  
The Harbor 25 is a stunning design with classic looks, a roomy cockpit, beautiful interior, inboard engine, and self-tacking roller furling jib.

# Harbor 20



## HARBOR 20

**The Boat that Brings Fun Back to Sailing**  
With its huge cockpit, a self-tacking jib, a roller furler, and an electric motor, the Harbor 20 is the perfect daysailer.

W.D. *Schock* CORP.

Est. 1946

Boat Builders • 23125 Temescal Canyon Rd., Corona, CA 92883 • (951) 277-3377 • Fax (951) 277-4104  
Website [www.wdschock.com](http://www.wdschock.com)



## WHERE DO YOU WANT TO GO?

Maretron can get you there using less fuel. We monitor fuel rate and report fuel economy so you can set engine RPM for the best fuel burning efficiency. And, we monitor tank levels to provide distance and time until empty so you have less to worry about. So get out your destination list and head off to sights unseen.

**Maretron**  
Leading the way in NMEA 2000® technology

To find out more about all of Maretron's vessel monitoring products, visit us at [www.maretron.com](http://www.maretron.com)  
866.550.9100

COVER CRAFT

## It's Only Fitting

that dodgers from Cover Craft have earned a reputation as the best available.



Order now for winter!

- Classic dodgers and biminis
- Wavestopper hardtop dodgers
- Drop-top dodgers for special applications
- Enclosures • Custom canvas

1230 Brickyard Cove Road, #106  
Pt. Richmond, CA 94801  
In Brickyard Cove Marina

**(510) 234-4400**

Quality  
Yacht  
Canvas

# ISLAND YACHT CLUB

Located in beautiful downtown Alameda's Alameda Marina  
1853 Clement Avenue  
(510) 521-2980

## CAPTURE THE POWER

*Where women go to  
learn the art of sailing...  
from other women.*



### Island Yacht Club's 16th Annual Northern California Women's Sailing Seminar<sup>©</sup> October 11-12

From basic sailing to advanced navigation, this weekend-long event features expert women sailors teaching women the art of sailing in both on-the-water and classroom sessions.

For applications call Janet at (415) 362-9533  
or Dawn at (510) 430-9990

Applications online at [www.iyc.org](http://www.iyc.org)

Use your new skills and join us for the

### JACK & JILL + 1

for Women Skippers

Triplehanded race on the Estuary.

Sunday, November 2

Call Joanne McFee (510) 521-7442

Both events are counters in the unofficial *Latitude 38* Women's Circuit!

## IYC MEMBERSHIP SPECIAL

Join now and enjoy five quarters of membership for the price of four! Annual dues for all of 2009 just \$350.

Call Pam Krawiec (510) 339-9451

For info go to [www.iyc.org](http://www.iyc.org)

## LETTERS

and Baie du Mondes, the trend in larger cats has been to more luxury and less performance. It's tough to have both, although some manufacturers do better at managing that compromise than others. Unless you plan to have a large paid crew or you sail with a large family, we'd suggest getting a cat in the 47- to 56-ft range. Why? Today's cats in that range tend to feel much larger than the same size cats of 10 or 20 years ago. We wish we could direct you to one place to see all the cats you should, but that's just not possible. You're going to have to do at least one relatively lengthy trip to the Caribbean and to the Med to see them all. Happy boat shopping!

### ↑↓ QUESTIONS LEFT UNASKED

In a recent issue, you published a letter from a man asking about a winter charter in Mexico. You discouraged a winter charter in the Sea of Cortez on the basis that the water would be too cold for swimming. Perhaps you didn't publish all of the man's letter, but I didn't read anything about him saying he or his family wanted to swim.

We spent a winter in the Sea of Cortez in '92-'93, and it was delightful. True, we didn't swim, but the anchorages were uncrowded and the weather was good. It's a beautiful area. Speaking of cold water, we spent a winter in Turkey, and even the Med is cold in winter.

It seems to me that you'd do better if you paid attention to what readers asked rather than reading something of your own into their letter.

Maxine Bailey  
Shingebiss II, Sceptre 43  
Seattle

Maxine — Thank you for your opinion, which we value tremendously based on your 14-year circumnavigation; however we couldn't disagree more. Our job is to inform, and we know that many folks are so unfamiliar with the Sea of Cortez that they don't even know what questions to ask. As such, we feel it's important for us to not only answer their questions, but to anticipate questions they should ask. If the man and his family don't care about swimming, they could ignore the information and no harm would have been done. If they did care about swimming, we may have saved them from an unsatisfactory experience. Too much information is rarely a problem, while too little information often is.

As for the Med, yes, we know it's too cold for swimming in the winter. So if somebody asked us for information about doing a winter charter in that part of the world, we'd make sure they knew it was cold at that time of year.

Our take on the Sea of Cortez is that it's usually warm enough for swimming until the early or middle parts of December. And November is almost always a terrific month in the Sea. But once a few Northers have come through, the water temperature usually drops quickly and doesn't get warm enough for comfortable swimming again until April. As you point out, not everyone cares about swimming during a charter, so for some, water temperature won't be an issue.

In a typical month, we receive a tremendous volume of letters. So if yours hasn't appeared, don't give up hope.

We welcome all letters that are of interest to sailors. Please include your name, your boat's name, hailing port, and, if possible, a way to contact you for clarifications.

By far the best way to send letters is to email them to [richard@latitude38.com](mailto:richard@latitude38.com). You can also mail them to 15 Locust, Mill Valley, CA, 94941, or fax them to (415) 383-5816.



# For more than 25 years, yacht owners have been able to trust **PACIFIC COAST CANVAS** for the best in design, service and quality.

## • **Offshore Dodger™**

Welded aft handrail  
Bolt-on side handrails  
Lexan windshields

## • **Baja Awning™**

Lightweight and waterproof  
Durable and easy to launch  
Multiple side screen configurations



*Check out the new 'Special Edition' Jeanneau 45, with Dave at Cruising Yachts; with our new offshore dodger.*

## • **Coastal Dodger™**

Affordable designs  
Same high quality materials  
Same superior workmanship

## • **Cruiser's Awning™**

Easy setup off your dodger  
Flies with no bulky frame  
Comes with shade screens

Open Monday-Friday 8:00-4:00  
Saturday by appointment  
**(510) 521-1829**



**2021 Alaska Packer Place  
Alameda, CA 94501  
Grand Marina**



**Colligo Marine™**

## Affordable Synthetic Shrouds

Featuring Dynex Dux™  
Low Stretch, Low Creep  
12-Strand Line

## Emergency Shroud Kit

- Easily Stowable
- Easily Installed
- No Corrosion

**480.703.3675**

**Colligomarine.com**

# CRUISING CATS USA

Your West Coast Dealer for  
**LAGOON CATAMARANS**

L380 on view Sept. 10-14  
at Boats Afloat, Seattle



**LAGOON 380**



**LAGOON 420**

All-time best selling cruising cat. As roomy as a 46' monohull – but up to 15 knots!

Either twin diesels or "hybrid" system (dsl./electric). Salon helm-station also available.



**LAGOON 440**



**LAGOON 500**

Huge galley and salon. Available with 3 or 4 suites. Serious bluewater cruiser.

Exceptional comfort and luxury afloat. Easily sailed by a couple – room for 8 guests.

San Francisco Bay  
Seattle

Call  
Toll Free

**(877) 937-2287**

**www.CruisingCatsUSA.com**

# Slip Into Someplace Comfortable

Silicon Valley's newest and most convenient marina



Discover a touch of Italy with the quickest access to South San Francisco Bay. Bair Island's management team is committed to providing a truly excellent home for your boat.

- ★ Slips and side-ties from 30' to 75'
- ★ 30 and 50 amp power
- ★ Cable TV, DSL and phone
- ★ Calm, quiet and protected
- ★ Free parking
- ★ Heated shower and laundry facilities
- ★ Walk to shops, restaurants and movies
- ★ Office open 7 days
- ★ Dock boxes with lighting
- ★ Kids playground

## BAIR ISLAND MARINA



702 Bair Island Road  
Redwood City, CA 94063  
650-701-0382  
www.greatslips.com

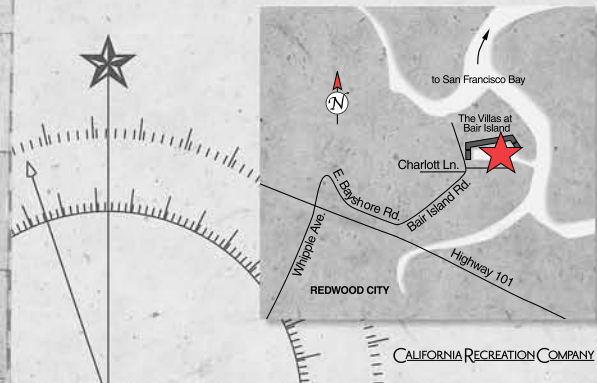

## LOOSE LIPS

Scintillating reading.

You're probably wondering what a photo of whitewater rafting — as nice a photo as it is — has to do with sailing. We were



SCOTT WEBER

*What we want to know is which article he's reading.*

wondering the same thing when we first got it. Upon closer inspection, we noted that the fellow in the front of the boat seemed engrossed in something more interesting than one more measly Class 3 rapid. Here's the note that accompanied the photo:

"I work as a photographer for a river rafting company called Sun Country Tours based in Bend, Oregon," wrote Scott Weber. "This shot was taken at a place called The Notch on the upper Deschutes River. On this particular raft, someone was reading a magazine as they came down, which seemed very odd, since the raft was approaching the most exciting and wettest part of the rapid. When I uploaded the photos, I zoomed in to see that he was reading *Latitude 38!* I really got a chuckle since I used to sail out of Half Moon Bay on a Brown 31 trimaran and looked forward to getting my monthly copy of your magazine." Years ago, there used to be an unofficial 'competition' of folks sending photos of themselves reading *Latitudes* in the darnedest places — the Great Wall, the South Pole and while skydiving were a few we remember. Could this be the first of a new crop of adventurous readers?

Sailing with soldiers.

Whether or not you support America's involvement in Iraq and Afghanistan, we hope everyone supports the soldiers themselves. The Presidio YC's Tim Blair, along with Nathan Johnson of the Department of Veterans Affairs Concord Vet Center, are hoping to put together a program to show that appreciation by taking veterans sailing. So far in its formative stages — they've only made five trips so far — it's something that everyone enjoyed thoroughly.

"The renewing power of sailing is pretty amazing," says Blair, who has taken many different 'health recovery' groups, including cancer patients, sailing over the years. He is currently reaching out to other veterans' groups and seeking support of the local community, while encouraging sailors elsewhere to set up similar programs. You can contact Tim at [ecoeathryacht@yahoo.com](mailto:ecoeathryacht@yahoo.com). The program operates as a non-profit 501 (c)(3).

The long way back to Iraq.

After a lengthy court battle, a yacht formerly owned by Saddam Hussein is going back to Iraq. This rather long and involved story began in 1981 when Hussein had the 270-ft luxury motor yacht built in Denmark — but never took delivery of it. Although



# Meet the Whitehall twins.



## She's all about full-body workouts.

Similar to an open water racing shell, the Whitehall Spirit™ Solo 14 is fitted with a sliding seat, foot stretcher and outriggers. At the catch, your legs and upper back muscles are engaged. By mid-stroke, the remaining major muscle groups in your back, shoulders and arms come into play. And at the end of each stroke (finish), your core muscles are engaged. It's a matter of fact that rowing, as a form of exercise, is more intense than jogging and bicycling, without putting undue strain on your joints.

## She just wants to play.

In seconds, the Solo 14 transforms into a sleek picnic boat. Able to accommodate up to four people, there's still room for the picnic basket, cooler and fishing gear. And with two sets of oarlocks, one or two people can row. The hull shape makes her nimble enough to explore the shallows of nearby shorelines. Yet the Solo 14's wide beam makes her more stable than any kayak for open water crossings. **Call 1(800) 663-7481 for a test-row in Victoria, Seattle or Sausalito.**

For information about the entire line of Whitehall Boats for rowing and sailing, visit [www.whitehallboats.com](http://www.whitehallboats.com).

Whitehall Spirit Solo 14 is a trademark of Whitehall Rowing & Sail. © Whitehall Reproductions Canada Ltd. 2008. All rights reserved.

## Have Perfect Starts Every Time

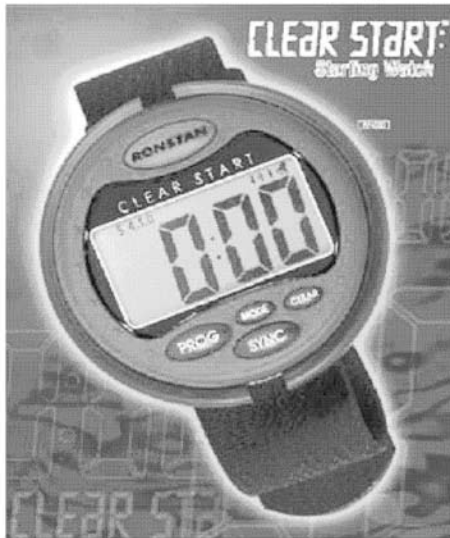

### Ronstan Clear Start Watch

#### Great Features:

- \*Count Down, Count Up
- \*Count Down, and keep repeating
- \*Can set for 1, 3, 5, or 10 minutes
- \*Can set for anytime for that matter
- \*Sync Button – if you missed the first signal, just hit Sync and you are right back on time again
- \*Warning Sounds
- \*Can switch to real time

Order online for delivery to your Doorstep  
**OnLineMarineStore.com**

## Margaret W Fago Yacht Portraits

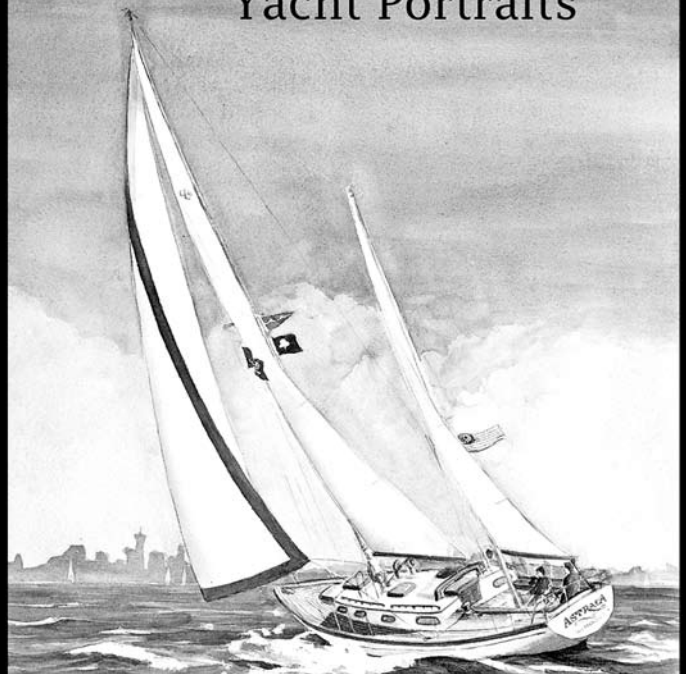

[mwfago@earthlink.net](mailto:mwfago@earthlink.net)  
 510 522-1309

[www.margaretfago.com](http://www.margaretfago.com)



C. SHERMAN JOHNSON CO. INC.  
**Johnson**  
*Marine Hardware*

**KEEPING YOU  
 CONNECTED  
 FOR 50 YEARS!**

Full Line of Hand Crimp,  
 Machine Swage and DIY  
 Cordage Fittings

**DIY Lifeline  
 Fittings**

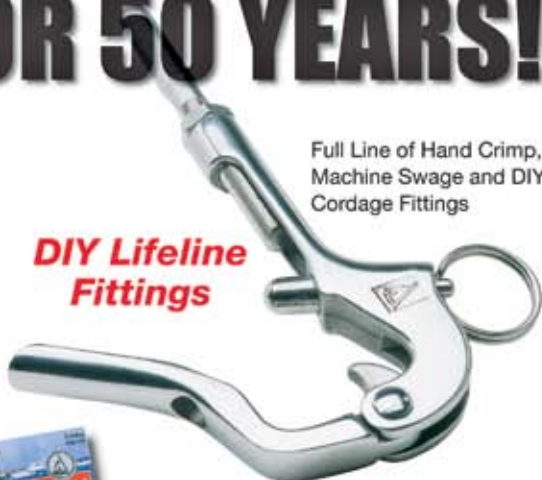

**Unique  
 Accessories**

Grab 'n Go™ Hook



**Rigging  
 Hardware**

Calibrated  
 Turnbuckle



C. Sherman Johnson Co., Inc.  
 East Haddam, CT  
 1-860-873-8697

[www.csjohnson.com](http://www.csjohnson.com)

## LOOSE LIPS

it had such special 'dictator options' as a missile defense system and mini-submarine (which he presumably would use to escape if the missile defense system blew a fuse or something), by most accounts, Hussein was so afraid of being attacked that he never set foot aboard. He even kept it in another country, Jeddah Harbor in Saudi Arabia.

Saddam named the boat *Quadissayat Saddam*, a reference to — what else? — a glorious 7th century battle in which Arab Muslims kicked some serious Persian butt. In a not-so-subtle message, the Saudi Royal family renamed the yacht *Al-Yamamah*, which means 'the dove.' Hey, it was in their dang harbor, they could name it what they wanted, right?

Before the U.S. invasion of Iraq in 2003, Saddam had the yacht moved to the Cayman Islands and registered it under the name of a British company. But it wasn't until he got executed in 2006 that things got *really* confusing. Basically, no one could figure out who owned the boat at that point. There was the British company, whose name was still on many of the documents. But then — somewhere, somehow — word started circulating that the yacht had been presented to Jordan's King Abdullah as a, ahem, 'souvenir.'

Last November, the British entity put *Al-Yamamah* up for sale. King Abdullah's yacht management company in the Caymans challenged them for ownership. And so did the Iraqi government, which had been following the yacht around for years. After months of testimony, a French court finally handed down a decision. (Why French? Because that's where the yacht ended up last year — don't ask us when or how it got there.) Their ruling: *Al-Yamamah* belonged to Iraq. Presumably, it will head there soon — for the first time.

**Eight bells.**

Dave Adams, longtime skipper of the Ranger 26 *MyToy*, sailed from this world on July 20. He was 77.

Dave and his wife Barbara nurtured many crew who performed consistently well over the last two decades. Under Dave's witticisms and skill as a helmsman/tactician/skipper, — and of course Barb's renowned meatloaf sandwiches — the *MyToy* crew never gave up, and sailed the boat to many podium finishes over the years.

As rewarding as it was to sail with Dave, most of the crew looked forward even more to the annual crew dinner, where Dave would award 'the trophy'. This bronze, sheetmetal clipper ship — attached to a music box that played *Moon River* — was awarded to the crewman who had performed the most bonehead move of the season. The first honoree in the mid-'80s was Bob Guletz who, if memory serves, might have hoisted the chute sideways. Anyhow, so many nameplates were added over the years that all the sails of the ship were covered, as well as every square inch of hull.

Among the more serious moments was a spring regatta a few years ago. *MyToy* was as usual leading her division when a crewmember saw the half-tonner *Hippo* go over in a spectacular wipe-out that threw a crewman overboard. The *MyToy* crew immediately doused the spinnaker and Dave turned around to render assistance. The *Toy* crew pulled the crewman, a guy named Warren, out of the water. (*Hippo* in the meantime, was still out of control and actually lost another man overboard before they could pull everything back together.) As another boat sailed past to win the division, *MyToy* was busy delivering Warren to the St. Francis YC docks where he was treated for mild hypothermia.

All who knew him will carry some fond memories. Fair winds and following seas, Dave.

— roger anderson and john harrison



# Own a dock on San Francisco Bay! Perfect Location - Great Investment

**EMERY COVE  
YACHT HARBOR**

**BUY A SLIP: Save money & earn equity!** Save 1/3 of your rental cost. Enjoy big tax savings as a slip owner. Emery Cove Yacht Harbor is the only marina on the Bay with FEE Simple (not a grounds lease) dockminium ownership.  
**OR RENT A SLIP: 35-60' slips!** Rates from \$8.25 to \$9.25.



**CALL FOR A MARKETING PACKAGE • 510-428-0505**

3300 Powell Street, Emeryville, CA 94608 • [www.emerycove.com](http://www.emerycove.com) • Email: [info@emerycove.com](mailto:info@emerycove.com)



## STAY COOL IN MEXICO

Quiet • Cool • Efficient

Stainless steel base and brackets for long life in the harsh marine environment. Quiet, high efficiency Carrier compressor for low running and starting current. Exceptionally low current draw – can easily be powered from batteries through inverter.



**SWEDISH MARINE**

1150 BRICKYARD COVE RD., SUITE B6  
PT. RICHMOND, CA 94801 (510) 234-9566

See us at the  
Boats Afloat Show  
September 10-14 • Seattle



**BRUCKMANN**

*Builders of Quality Yachts*

**BRUCKMANN 50**  
Performance  
Pilothouse



*Perfect balance of power and sail, blending technology and tradition*

**BRUCKMANN 42**  
Daysailer



*Simple • Elegant • Comfortable*

**International Marine**  
MANAGEMENT INC.

**206.282.4262**

[www.immservice.com](http://www.immservice.com)

Chandler's Cove Marina • 901 Fairview Ave. North • Seattle, WA



# SIGHTINGS

## the big one's coming to town!

If you love big boats and a sailing spectacle, you're going to love the news we received in an August 8 email from Tom Perkins of Belvedere: "I want to let you know that *Maltese Falcon* will be arriving in San Francisco in late September, and will be on the Bay most



**Tom Perkins.**

of October. When our ETA is clearer, I will email you with the most likely time of day for our arrival under the bridge. *Atlantide* will also be there."

Trust us, no sailor is going to want to miss this event. As *Falcon* is nearly the length of a football field, she will blow your mind.

*Falcon*, of course, is the 289-ft *Maltese Falcon*, which by most forms of measurement is the largest sailboat in the world.

While Jim Clark's *Athena* and Barry Diller's *Eos* are both slightly longer, they are so thanks to bowsprits, and have significantly shorter waterlines and less displacement than does *Falcon*. In any event, thanks to her

unique Dyna-Rig — three free-standing masts — she's been the most celebrated new sailing yacht in recent memory. *Atlantide* is a magnificent 122-ft motoryacht that was built in 1930, and impeccably restored by Perkins in '99.

"I am hoping to use *Falcon* to assist in the Leukemia Cup charity event on October 4 and 5," continues Perkins. "My friend Rupert Murdoch will be the guest speaker the evening of October 4." Murdoch, of course, is the owner of News Corporation, which recently purchased *The Wall Street Journal*. He's also a Perini Navi owner. Tickets for Murdoch's talk are \$1,000 each — hey, remember that this is for an excellent cause — and can be obtained by calling Leslie Crouch at (415) 625-1133.

"You may have heard that *Falcon* has been for sale," Perkins also notes in his email. "She is now off the market, as I am taking on a 50% partner in the boat. The new co-owner requests confidentiality, so I can't share the name." The yacht had been listed for sale at \$180 million. And no, that's not a typo.

Perkins is best known for inventing low-cost lasers, for being largely responsible for getting Hewlett-Packard into computers, but above all, for being on the ground floor — with Kleiner Perkins Caufield & Byers — in venture capitalism, a key factor in Silicon Valley becoming Silicon Valley. For a very interesting account of Perkins' business and sailing life, you should pick up a copy of his book *Valley Boy, the Education of Tom Perkins* from Gotham Books.

We'll be keeping everyone posted on the arrival of *Falcon* on *Electronic Latitude*, but as Hugues Wisniewski reports, you can also follow the great yacht's progress by visiting [www.symaltesefalcon.com/tracking.asp](http://www.symaltesefalcon.com/tracking.asp).

— richard

## what's the deal with ais?

Automatic Identification Systems (AIS) have been in the sailing news a little more lately following the report that some officials in Mexico were thinking about possibly trying to make them mandatory on all vessels — including recreational vessels — in Mexico. We don't think this is going to happen anytime soon, in large part because it's based on the mistaken belief that AIS is required on all boats in the United States and Canada. And what's needed to meet the supposed

continued on outside column of next sightings page

## other ways

Okay, not everyone can afford to pay \$1,000 a plate for an evening with Rupert Murdoch (see story at left) — even if it is for a good cause. But there are still many ways you can contribute to the Leukemia Cup, and by extension the Leukemia and Lymphoma Society, which works tirelessly to treat and hopefully one day cure blood cancers.

The easiest way is to enter and sail your boat in SFYC's Leukemia Cup Re-



Tom Perkins' magnificent yachts '*Maltese Falcon*' (spread) and '*Atlantide*' will grace the waters of the Bay later this month.





## to donate

gatta October 4-5. You could also compete for prizes based on the amount of money the crew of your boat brings in. Or you could contribute directly to one of many existing fundraising campaigns, such as that of Ian Charles.

Regular readers may know about Ian through a *Sightings* item in the July issue. A 40-year-old local business owner, father, America's Cup sailor and triathlete,

continued in middle column of next sightings page

## ais — cont'd

requirement isn't available in the United States.

In any event, the news has raised the profile of AIS, and emphasized exactly how valuable such units can be. So let's review what AIS does and is. Very briefly, *AIS transponders* are all about preventing collisions. They do this by allowing AIS-equipped vessels to tell all other AIS-equipped vessels in VHF range who, what, and where they are, as well as where they are going, at what speed, and all kinds of other information. *AIS receivers* allow vessels to find out the same information about all other AIS transponder-equipped vessels within their VHF range.

continued on outside column of next sightings page



PHOTOS COURTESY TOM PERKINS



# SIGHTINGS

## ais — cont'd

If you want to know how AIS work, what kind of information each of the two classes of units provide, and how frequently they transmit, visit the Coast Guard website at [www.navcen.uscg.gov/enav/ais](http://www.navcen.uscg.gov/enav/ais). The system and technology are very complicated, but the information provided about each vessel exceeds what you really need to know.

All Class A AIS units, which are now required on all vessels over 300 gross tons that travel internationally, as well as all passenger ships, include both transponders and receivers. They transmit their signal every two to 10 seconds while underway, and every three min-

continued on outside column of next sightings page

## donate

Ian was diagnosed with multiple myeloma in April, shortly after he had been asked to chair the local edition of the 2008 Leukemia Cup Regatta.

And running it he is. In addition to managing the event, he's committed to personally raising \$100,000 of the hoped-for \$500,000 goal for the San Francisco edition of the regatta. (There are 40 Leukemia Cups held across the country every



*Easy, breezy, beautiful — August was a little light in terms of wind but that didn't stop these sailors from making a big splash. Clockwise from above, a tip o' the cap to you; 'Shangra La' finds paradise in The Slot; finding comfort behind Alcatraz; 'Little Svendel' gets folksy in Raccoon Strait; wonder which of the four are 'J', 'G', 'P' and 'C'; 'Josephine' pounds toward the Gate; gettin' catty.*





## — cont'd

year.) Donations to Ian's campaign can be made through [www.active.com/donate/leukemiacupgs/IanCharles](http://www.active.com/donate/leukemiacupgs/IanCharles).

No matter what contribution method you're most comfortable with, we think it would be a great gesture to do it in the name of Mark Rudiger, a close and valued member of our local sailing family who lost his battle with lymphoma in June.

—jr

## ais — cont'd

utes while at anchor. Because they do it at 20 watts of power, they are relatively power-hungry, and therefore not really for small vessels. The least expensive one we could find is the Comer for \$2,400.

Class B units, which could be called 'AIS Lite', have been developed for recreational boats that aren't required to have Class A units. Some have transponders and receivers just like the Class A units, but they don't transmit as much information as often or as far. There are also Class B units that receive only. Some of the Class B units are free-standing, while others are 'black boxes' that hook up to chartplotters

continued on outside column of next sightings page



# SIGHTINGS

## ais — cont'd

and GPS units.

Because Class B transponders have yet to be approved by the Federal Communications Commission, they are not available for sale in the United States and cannot legally be used in U.S. territorial waters. However, they can be purchased and used everywhere else in the world. For instance, Jim Kellam, a Canadian sailor in the recent Singlehanded TransPac, had a Class B transmit unit and uses it whenever he's outside of U.S. waters. One of the least expensive Class B transmit-and-receive units we could find is the Simrad AI50 for \$1,300.

Class B receive-only black boxes can be purchased for as little

continued on outside column of next sightings page

## if you wear only one

Concerned that lives are being put at risk because sailors are not using their PFDs, *Latitude 38*, the United States Safe Sailing Association, and formidable cruiser Heather Corsaro of Monterey decided to coordinate their efforts to remind and encourage everyone to use their PFDs.

"A PFD in a locker isn't going to be much help if you go overboard," says Corsaro. "And don't think it can't happen to you. A broach threw a woman off a boat in the recent Santa Barbara to King

**"PFDs don't work if you don't use 'em," admonishes a well-'outfitted' Heather.**





## thing while sailing

Harbor Race that I did, and she had to swim for 20 to 30 minutes without the benefit of a PFD. She survived, thank god, but Coast Guard statistics show that not wearing a PFD is one of the leading factors in boating deaths. So if my being exploited results in every guy — and gal — boatowner putting my photo on their bulkhead, which in turn results in more people using their PFDs, I'll still be able to look at myself in the mirror.”

— richard



## ais — cont'd

as \$200. If you read this month's *Letters*, you'll find that boatowners who have them love them — for entertainment as well as safety purposes!

So far, the consensus from the sailing community is that folks with recreational boats only need the less power-hungry Class B units, and that even if the Class B transponders were available and legal in the U.S., all that's really needed is a receive-only unit. Some would argue that having the ability to transmit would also be nice, but many seem to think that since small boats staying out of the path of big vessels is a matter of life and death, having the transmit capability might provide a false sense of security.

AIS is excellent on the Bay as well as out on the ocean. Have you ever been sailing on the Central Bay, seen three ships approaching from different directions, and wished to heck you knew what their intentions were so you could stay well clear of them? You can get all this information with a Class B receive-only unit.

When out on the ocean, Class B receive-only units provide sailors with all the information they need to stay clear of shipping. Some AIS units have 'guards', which sound an alarm any time a vessel is predicted to come within one's comfort zone. We're told that the AIS guards are more reliable than radar guards because they're not affected by things like heavy rain. On the other hand, lots of vessels under 300 gross tons don't have AIS, in which case the AIS guard would be worthless. As always, it's important to know the limitations of your equipment.

For more information on the practical use of AIS units, see this month's *Letters*. We'll have more letters on the subject next month. In addition, we'll be sure to let you know as soon as the FCC approves Class B transponder units. Meanwhile, we think a Class B receiver is a heck of a bang for any sailor's safety buck.

— richard

## gulliver will travel no more

Just like the fictional 18th century traveler of the same name, Gulliver the parrot has had many adventures in his young life. You'll recall that the five-year-old blue and gold macaw was abandoned — along with Snickers the cocker spaniel pup — by his owners on Fanning Island last December after their sailboat wrecked on the island's reef. Cruisers Robby and Lorraine Coleman of the Honolulu-based Angelman ketch *Southern Cross* first sounded the alarm that the pets were slated for execution by the Kiribati government if they weren't repatriated. Thanks to the efforts of hundreds of animal lovers, the final chapter of this dramatic tale has come to a close.

"Gulliver was finally given his U.S. citizenship and released from quarantine on August 7," said Sybil Erden, "exactly eight months to the day after he had shipwrecked in the South Pacific." Erden is the executive director of The Oasis Sanctuary, the Arizona-based bird sanctuary that spent \$15,000 and countless hours of volunteer work to rescue the bird. Erden describes Gulliver as a "spokesparrot" for neglected and abused parrots everywhere.

Meanwhile, Gulliver's four-footed pal Snickers — now dubbed

continued on outside column of next sightings page



**Gulliver was saved from the stewpot in Kiribati when he said 'Hello'.**

SYBIL ERDEN / THE OASIS SANCTUARY

# SIGHTINGS

## **gulliver — cont'd**

Curly Boy — has been thriving at his new home in Las Vegas under the patient care of Jack Joslin. “The Wild Beast of Fanning that arrived at my home in April has gone dormant,” Joslin reported. “I’m pleased to report that Snickers is, in almost all ways, just a happy, playful, very smart, normal cocker spaniel. Right away, he seemed to understand and accept that I was the alpha dog in this pack, and he bonded with me quickly. That was good for me and him, but not so much for my other dog, Missy. He, of course, only knew that aggressive assertion of his desires resulted in satisfaction. Time and attention were necessary to repair his aggressive tendencies.

“After the first week, I was able to walk them together. Then I began to notice that he would occasionally look at her to try to figure out, for example, how alarmed to be if we walked by a barking dog. Once he saw that she ignored the distraction, he began to do likewise. I’d say it was maybe three weeks ago that she actually played with him. He’d been trying for quite awhile to engage her, but she’d ignore him. Once she ‘agreed’ to play, though, I knew it would all be OK. He really is the sweetest little guy.”

On August 9, Snickers and Gulliver were reunited, if only for the day, at a celebration in San Diego. Erden reports that quarantine was tough on the bird as he was in cramped quarters for a month, but now that he’s able to stretch his wings in the large macaw aviary at The Oasis, he’s settling in nicely. “His life will be boring now,” Erden laughed.

— ladonna

## **cruiser murdered on lake izabal**

It might never have happened for a number of reasons, and it only led to more deaths. Daniel Dryden, 66, was murdered at about 10 p.m. on August 9 aboard his



THE DRYDEN FAMILY

**Nancy and Daniel Dryden.**

and wife Nancy’s Southern Cross 39 *Sunday’s Child* as the boat lay at anchor on Guatemala’s Lake Izabal. Four locals armed with machetes had come out to the boat as the Drydens were preparing dinner, and demanded U.S. dollars as well as the boat’s outboard motor. After Dryden and his wife had been “poked and stabbed” with machetes, and with Nancy held in a different cabin, “Dan grabbed his machete and fought to the death.” It was all over in 10 minutes. Although Nancy suffered a punctured lung, she survived, and at press time she had recovered enough to be released from the hospital.

The Drydens moved to Sutton, Alaska, in the ‘70s, where Daniel became a truck driver on the TransAlaska Pipeline. In the mid-’70s, they cruised the North Sea and across the Atlantic to the Caribbean aboard *Janetta*. Daniel later started a construction company in Alaska, and most recently worked restoring salmon habitats. Nancy was a physical therapist for the state, working with children. The couple had reportedly decided to build a home in Mexico, but first went to visit friends who own a hotel in Guatemala.

Because Lake Izabal is about 20 miles up the sometimes narrow Rio Dulce River, it’s long been a popular place for cruising boats to sit out the Caribbean’s summer hurricane season. Indeed, there are several boatyards and small marinas in the area, all of which are surrounded by thick jungle. While at Lake Izabal, the Drydens came across a Southern Cross 39 and decided to buy *Sunday’s Child* to do some more cruising. They spent six months enjoying beautiful

continued on outside column of next sightings page

## **scientists and sailors**

“I have made four Pacific Puddle Jumps (2003, 2005, 2006 and 2007) and wanted to find a way to help the islands I have visited on my passages,” says Bob Bechler of the Gulfstar 44 *Sisiutl*. He found what he was looking for in a fledgling New Zealand-based organization called Oceanswatch.

Founded by professional yacht skipper Chris Bone, Oceanswatch is described as a rapidly growing network of sailors, divers, marine scientists and other marine and humanitarian activists focused on using their skills to help tackle the challenges of global warming, collapsing marine ecosystems and the effects on the coastal communities that they support.

*In places like Papua New Guinea, where Oceanswatch is currently conducting conservation and education projects, sailors have to make do with what they have.*





## work together

More than simply a forum for discussion and networking, Oceanswatch will use sailing vessels and skilled yachtsmen to take volunteers, humanitarian aid workers, researchers and film-makers to the endangered marine ecosystems and struggling coastal communities on our planet. The group currently has projects in Vanuatu and Papua New Guinea, with future efforts being planned for Tonga and other South Pacific islands.

We encourage both active and arm-chair cruisers to check out the efforts of this well-intentioned group via the website [www.oceanswatch.org](http://www.oceanswatch.org) (that's oceans, with an 's' and .org, not .com).

— andy

## murder — cont'd

Guatemala and getting the boat ready for sea. On the night they were attacked, they'd anchored a short distance off the marina to get used to living free of land.

Thanks to a long and brutal civil war that ended in '96, and more recently, extensive drug trafficking and corruption, much of impoverished Guatemala is lawless and violent. Tourists, including cruisers, are generally more immune than locals from violent crime, as even criminals understand how important foreign money is to the economy and area's reputation. Yes, there have always been a number of thefts and burglaries from boats on the Rio Dulce, but we can't recall any cruisers being badly injured or killed until this incident.

It's not clear why Dryden decided to fight back. Cruisers will remember that New Zealand sailing legend Peter Blake was killed on his boat during a robbery attempt at the mouth of the Amazon River. Some who were aboard believe he wouldn't have been killed had he not tried to counter attack with a weapon that misfired.

continued on outside column of next sightings page



## murder — cont'd

The Rio Dulce crime spree did not end with the tragedy on *Sunday's Child*. Roy McNett, editor of the *Rio Dulce Chisme-Vindicator* ezine, reported that four other sailboats — *Mima*, *Dream Odyssey*, *Ctoy*, and *Phalcor* — anchored between Livingston (at the mouth of the Rio Dulce) and Texan Bay, were visited by intruders a night or two later. Mark and Sue (no last names given) and their two children reported that their boat *Mima* was boarded by five men with machetes and a gun. The men demanded U.S. dollars — the same demand made to the Drydens — but the incident ended without anyone being hurt. The sailing vessel *Dream Odyssey*, owner and type unknown, also reported being boarded. With the husband and wife cruising team unable to do anything but watch helplessly, many items of value were taken. The sailing vessel *Ctoy*, owner's name and type also unknown, was boarded, too. Finally, a Brit named John aboard the sailing vessel *Phalcor* reported that a group of men tried to rip open the hatch to his boat about 2 a.m. He managed to keep them out, but the men used bolt cutters to cut the chain securing his portable generator to the boat. In their haste to leave, the thieves left behind a machete and the label from a new pair of large bolt cutters. Fortunately, none of these cruisers was injured during any of the attempted robberies.

A day or two later, Carlos Ernesto Lemus Hernandez, 19, and his brother Elfidio Concepción Lemus Hernandez, 33, both from the village of Esmeralda, were arrested in the slaying of Dryden. They were taken into custody after a search of their home resulted in the discovery of an ice pick believed to have been used in the crime, binoculars believed to have been taken from the Drydens' sailboat, and a quantity of marijuana. These two suspects were said to have been "under the protection" of a woman known as Reyna del Sur — Queen of the South — who lived in nearby Morales. Authorities believe that she was behind various illegal activities in the area, including the stealing of outboard motors and the selling of drugs. Curiously, the night before the brothers were arrested, Reyna and her 14-year-old son were killed at the nearby Backpacker's Hotel.

Yet even that wasn't the end of the bloodletting that had started with such a senseless murder. According to McNett's last report: "Local justice — it's not a pretty word — may have been served on the night of August 14, when two men were killed in a shooting in the small town of Seja, about five miles from Fronteras and the Rio Dulce. The two men are believed to have been involved in the August 9 robbery and murder of Daniel Dryden. Their identities have not been made available, but several sources indicate this was a 'cleansing' of the Dryden murder."

We're not positive what "cleansing" means in this context, but we assume it means that the police or local businessmen, or somebody acting on behalf of them, acted as an on-the-spot judge, jury and executioner of the suspects. Apparently everyone knew who had committed the crime, but up until the two were killed, didn't want to risk their lives identifying the subjects. From start to finish, it was a horrible, senseless chain of events.

Dryden, who lived a passionate life, is remembered at *danieldryden.blogspot.com*. Among the contributors are Steve and June Jones of the Bay Area. The two couples met in the Cardnells Boatyard on the east coast of England in '76, where the Drydens had hauled *Janetta*, and where the Joneses had just purchased *Syrinx*. They met again on the Thames River, and later Daniel and Nancy helped sail *Syrinx* to Plymouth prior to the Joneses' Atlantic crossing. "It was a couple of years before we saw the Drydens again in the Virgin Islands," Steve and June wrote, "but they already held and continue to hold a place in our hearts that defies years, distance and now Dan's passing."

While incidents such as the murder of Daniel Dryden are rare in the cruising world, it's understandable that cruisers want to take whatever precautions and to defend themselves the best they can.

continued on outside column of next sightings page

## mexico only

A long time ago, in a galaxy far, far away, entire pages of this magazine were crammed full of names — endless oceans of names. Alongside each were contact numbers and codes for skills, experience and desires. We called it the Crew List and it launched many a dream, matching people who wanted to crew with boat owners for any type of sailing, from simple daysailing to racing to long distance cruising, with boat-swapping and co-chartering thrown in for good measure.





## crew list party

You won't find those information-filled pages any more. But you will still find the Crew Lists — bigger and better and more immediate than ever before — on our website, [www.latitude38.com](http://www.latitude38.com). And unlike the weeks-long process of old, in the time it takes you to read this *Sightings* item, you can become part of the Crew List if you want. And if you can arrange to jump off the treadmill for a few months this fall or winter, perhaps you can join

continued in middle column of next sightings page

## murder — cont'd

Carrying guns is always risky as they are illegal in many countries, they're difficult to keep in good order on a boat, and there's always the risk of being outgunned by the bad guys. If confronted by thieves who either aren't armed, or have only knives or machetes, we can't help thinking that a Taser C2 or two might be the answer. This is a modified version of what police use but designed exclusively for self-defense, and at a distance of up to 15 feet, completely disables attackers for 30 seconds. Yet because it's the size and shape of a lady shaver, and comes in nine designer colors — including animal print — it's inconspicuous. At a cost of \$299 each, one or two might be just the thing. Send your thoughts to [richard@latitude38.com](mailto:richard@latitude38.com).

— richard

*"Hey, give me a little ease on the traveller, will ya?" Summer sailing on the Bay usually means tucking a reef in the main but not for the thrill-loving skipper of 'Anna Bee'.*



PETER LYONS / WWW.LYONSIIMAGING.COM

# SIGHTINGS

## elsewhere lost in the south pacific

Do you believe in fate? Yes or no, who wouldn't wonder about a boat whose steering failed at the very moment it was needed most? That's exactly what happened to Matt and Judy Johnson of Antioch at the end of June. Seconds after the wheel spun uselessly, *Elsewhere*, the Cabo Rico 38 they had cruised aboard for nine years was driven onto a South Pacific reef. By early afternoon that same day, June 28, Matt knew they'd lost her.

The Johnsons took off in 1999 as part of that year's Baja Ha-Ha.

Afterward, they continued south, visiting many Mexican ports, and "every country in Central America except Belize and Nicaragua." In 2005, they finally hopped off for points west and south, stopping at the Galapagos and continuing on to fabled isles of the South Pacific — the Tuamotus, Cooks, Societies and so on. Matt and Judy are 'smell the roses' type cruisers, preferring to go slow, explore and savor their stops. So the grand plan was to continue cruising the area — with

an occasional month or two back home in Antioch — for five years before moving on to Australia.

By June of this year, they were at Majuro Atoll. Judy had flown home and returned early in the month with grandson Tyler in tow. Matt says it was a special delight watching the boisterous 12-year-old take to the cruising life. They spent several weeks checking out some world-reknonwed diving areas near Majuro before upping anchor for the next stop, Aur Atoll, 65 miles north.

They arrived off the entrance to the southern pass through the reef on the morning of June 28. They took down the sails, started the engine and triple checked the charts. It was a tricky pass, about 150 yards wide and perhaps a quarter mile long, with a small coral island in the middle about halfway through. And on this day, the wind and waves were blowing diagonally across their route. But it wasn't the worst they'd seen. As they'd done many times before, Matt went forward to keep a lookout in the crystal clear water while Judy took the helm. Young Tyler kept a lookout amidships. Judy gunned the engine and in they went.

"I saw pretty quickly that we were getting pushed a little to the left, so I yelled for Judy to come right a bit," said Matt. "She turned the wheel and nothing happened. It just spun." Within seconds, *Elsewhere* slammed onto the reef and went over on her port side.

The conditions at the time were 15 knots of wind and 4-ft wind waves. It was almost high tide, so the reef was covered by about three feet of water. *Elsewhere* drew six.

"From the moment we hit, the motion was horrible," says Johnson. "We were really getting bounced and banged around." Matt managed to get a bow anchor down, but no amount of backing and filling of the engine budged the boat. While he was doing that, Judy got on the VHF and called "any boat" for assistance. She was answered immediately by *Blue Star*, which said they would send a boat from the other end of the island right away.

With Tyler getting increasingly frightened by the pounding, Matt decided to launch their Zodiac. He attached it to the boat with 100 feet of line and the three of them floated out over the reef in somewhat calmer water. Though it was painful to watch their beloved *Elsewhere* pound on the reef, her rail was still above water. Matt and Judy both thought it would just be a matter of time before she could be pulled back into deeper water.

*Blue Star* turned out to be the 144-ft megayacht owned by Vladi-

continued on outside column of next sightings page

## crew list

one of hundreds of boats headed south of the border in the Mexico cruising class of '08-09. If you own a boat but didn't think you'd be ready, perhaps by soliciting on the Crew List you could hook up with a few people and get 'er done. It's all as easy as logging on and filling out a few simple forms.

But please, folks, don't take part unless you're going to follow through — and please realize that we are just the go-between in the process. *Latitude 38* neither makes nor implies any guarantee, warranty or recommendation regarding the

COURTESY ELSEWHERE



**Matt and Judy Johnson.**



**Sailing in a summer beer can race in Santa Barbara comes with its own challenges — like how much sunscreen to bring along.**





**— cont'd**

character of the individuals participating in the Crew List, the condition of their boats, or any weather or sea conditions you may encounter. You must judge those things for yourself.

Another change from years past is that the Crew List Party is now held in September — on the 10th this year — which is about three weeks earlier than in the past. This is also a function of the immediacy of having the Crew List on the internet, and allows folks that much more time to make connections. As well

continued in middle column of next sightings page

***elsewhere* — cont'd**

mir Gusinsky, a Russian-Israeli media tycoon who had to flee Russia after criticizing the government. The 'boat' they'd sent was a 30-ft RIB powered by a 150-hp outboard. It took Tyler and Judy aboard, then delivered Matt back aboard *Elsewhere* where he rigged a long tow line. But the inflatable couldn't move the bigger boat.

By this time, *Blue Star* herself hove into view and anchored nearby. The RIB delivered Judy and Tyler to the yacht, and returned — accompanied by an identical sistership. But even their combined 300 hp could not even swing *Elsewhere's* bow into the wind. They tried attaching a halyard to one boat (to heel the sailboat over more) while the other pulled. But nothing worked. *Elsewhere* was stuck fast. At some point in all this, Matt says water started flooding into the boat from below, a sure sign the hull had been breached. After that, *Else-*

continued on outside column of next sightings page



PHOTOS LATITUDE / RICHARD

# SIGHTINGS

## *elsewhere* — cont'd

where settled even farther onto the reef and waves began to wash over her stern quarter directly into the cockpit and down below.

"That's when it first occurred to me that we were probably going to lose her," says Matt. Still, he and the *Blue Star* guys worked through the day. By early evening, the 64-year-old Johnson could work no more, and the work party adjourned to the yacht.

If it weren't for the sad fact that he was right about losing the boat, the rest of this story would have almost comedic overtones. That first (sleepless) night and part of the next day, the Johnsons enjoyed the "incredible opulence" aboard *Blue Star* — including being given their own cabin and dining with Gusinsky and his wife and two children — the younger of whom became pals with Tyler. Everyone aboard, from the owner to 'Captain Dave', an American, to the mostly Australian crew, was very nice and supportive. While Matt was getting cleaned up, a boarding party from *Blue Star* returned to *Elsewhere* and salvaged everything they could. (Matt had grabbed a briefcase full of passports, airline tickets and other important papers when they first

continued on outside column of next sightings page

## crew list

as being a nice, neutral place to first meet your new crew or skipper, you can make your actual crew/boat connections at the party. Everyone wears color-coded name tags, so it's easy to tell 'Want To Crew' folks from those who 'Need Crew'. If you really want to 'work' the crowd, bring a colorful sign, wear goofy clothes and/or have one-page sailing resumes available to hand out to interested crew or boat owners. Extroverts are the proverbial early birds at the Crew List Parties, so don't be a wallflower.

As mentioned, this year's Crew List Party will be held at the Encinal YC on Wednesday, September 10. Admission at the door is \$7 per person and we would *really, really* appreciate exact change.



PHOTOS COURTESY ELSEWHERE



## — cont'd

Hours are 6-9 p.m. Encinal YC is in Alameda. If you've never been there, you can find detailed directions on the Crew List section of our website.

Since this fall's Crew Party is specifically aimed at those heading to Mexico, we piggy back it with a Baja Ha-Ha Cruiser's Rally Reunion — and also invite those currently signed up for the 2008 Ha-Ha. There will also be gear demos, T-shirt giveaways, munchies, a no host bar, a slide show — and even a few genuine editorial types in full schmooze mode. Bottom line: No Amway convention in the world will get you as pumped about changing your life as the Mexico Only Crew Party. We hope to see you there!

— jr

**When the Johnsons returned to 'Elsewhere', she was completely stripped (left). Even her bulkheads had been 'salvaged' (below).**

## elsewhere — cont'd

boarded the dinghy.) Sadly, much was lost, including Matt's detailed diary of their travels.

Captain Dave had contacted a salvage company in Majuro, which promised to have a tug on scene by first light the next day.

At about 10:30 a.m. on the 29th, an object on the horizon slowly took form. But it wasn't a tug. It was an ancient landing craft that looked like it had been the first ashore at Omaha Beach back in '44 and never been repaired. Plus it was full of lumber, bricks, cement



'Elsewhere' on a happier day.

and other building materials. Long story short, the tug had left the previous day on a tow job to Australia, so the company diverted the landing craft, the *Debra K*. The Johnsons thanked Gusinsky and his family and crew profusely and transferred to the *Debra K*.

Talk about contrast. Except for the continued kindness of the captain and crew, all native islanders, the *Debra K* was in every way the antithesis of *Blue Star*. The Johnsons were given a cabin — with apologies from the captain for the smell. They'd poisoned rats earlier and one or more had died somewhere in the overhead wiring. The poison apparently had no effect on cockroaches, which were everywhere. The Americans were especially shocked to learn there was exactly one utensil on board: a fork. And it belonged to the captain. Otherwise, the crew just ate with their fingers from an always-bubbling pot of rice. And when they caught fish, they'd just carve off a piece (okay, they had knives, too) and eat it raw.

As if matters weren't unpleasant enough, the *Debra K* crew couldn't help with *Elsewhere* until they'd delivered the building materials to Wotje Atoll, about 90 miles away. That took the next four days.

When Matt and Judy finally returned to *Elsewhere* — on the 4th of July of all days — what little hope they had of salvaging her evaporated instantly. In their absence, the boat had been totally stripped. Even bulkheads had been pried out. Matt assigned no blame to anyone, and saw no point in barging into the little village five miles away to try to reclaim anything. He and Judy simply said their goodbyes to the boat that had sailed them so many miles on so many adventures, and hitched a ride with the *Debra K* on her way back to Majuro.

At this writing, the Johnsons are home in Antioch, readjusting to life ashore. The good news in all of this is that the boat was insured. So far, Matt says Commandeur Insurance, a Dutch company, has "treated

me very well." And yes, he's already looking around for another boat, possibly one that's already in American Samoa. From there, Matt and Judy will pick up where they left off. "After all," he says, "we still have a few years left in the grand plan."

— jr



# SIGHTINGS

## big boat series preview

For a racer, nothing says September on the Bay like St. Francis YC's Rolex Big Boat Series. Long the premier inshore event on the West Coast, it typically draws some of the world's sweetest boats and big-name racers.

This year's event — September 11-14 — shouldn't be any different considering the list of 70 entries as of press time. As it stands right now, there are eight divisions planned. On the one design side, there'll be J/105s Melges 32s, J/120s, Express 37s, Beneteau 36.7s, Sydney 38s and 1D 35s.

As the first event to bring the IRC rating system to the U.S., the

continued on outside column of next sightings page

## fun facts about

Based on surveys returned by 99 of the 150 finishers in the last Baja Ha-Ha, the following interesting facts were learned:

1) As many have wrongly assumed, it's not an event dominated by novice sailors — not by a long shot. Prior to the Ha-Ha, the average skipper had been sailing for 26.7 years. However — and this is very interesting — for more than 50% of them, it would be their "first significant trip."

2) The average boat length was 42.6



LATITUDE / RICHARD



## the ha-ha

feet, the average age was 17.6 years. Both of these numbers are nearly identical to last year.

3) Of those who responded to the survey, 13% were doing the Ha-Ha only and then returning home; 22% were 'commuter cruising', meaning they would commute between their work in the States and playing on their boats in Mexico; 14% planned to cruise for one season in

continued in middle column of next sightings page



**Big Boat Blowout — September is the month for catching all the action in the Big Boat Series.**

## big boat — cont'd

Big Boat Series will once again use it for the handicap division, which has a pretty diverse range amongst the 29 boats entered so far, from Jean-Yves Lendormy's reigning class D winner *Acabar* to Bill Turpin's R/P 78 *Akela*. John Kilroy's *Samba Pa Ti* will be back to defend her class title, up against a brand new IRC R/P 52 *Vincitore* — essentially a stretched version of *Criminal Mischief*.

While the 70 entries are a far cry from last year's 112, there are only six J/105s signed up, and if last year is any indication, that number is likely to climb closer to 36. That's not a wild guess — the class' North American Championships were being hosted by StFYC at press time with that number of entries.

There's seven races scheduled for the Bay tour on Sunday, and there should be plenty of chances for good viewing from just about everywhere on the Cityfront, so if you didn't snag a ride, you can still catch all the action, which you won't want to miss, especially if anyone starts using the breakwater for 'arena sailing'.

More details are at [www.stfyc.com](http://www.stfyc.com).

— rob

## teen solo sailors aim for record

As we were reminded during last month's coverage of the Olympics, everybody loves a hero — especially a sports hero. In the realm of sailing, one of the newest heroes to inspire public awe is a self-assured Southern California sailor named Zac Sunderland, who, at age 16, is poised to become the youngest person to circumnavigate the globe singlehanded.

As we go to press, he is headed west, nearing the notorious Torres Strait, having travelled roughly a third of the way along his proposed route, which will take him around the Cape of Good Hope and through the Panama Canal.

Although we've never met Zac, we could tell from the brief pre-departure phone interview we did with him that he is mature beyond his years. Born into a sailing family, he's literally been around boats since the day he was brought home from the hospital as a newborn. He figures that the original inspiration for attempting this feat came at the age of 7 or 8, when his mom read him a book about Robin Lee Graham's world-famous solo voyage aboard *Dove*.

Since then, he's logged thousands of sea miles, many of them crewing for his dad, Laurence, who makes his living as a captain and boatwright. Once the idea was hatched to challenge the current record, set by Australian Jesse Martin (then 18) in 1999 aboard his S&S 34 *Lionheart*, Zac traded his life savings for a well-used Islander 36, *Intrepid*, and set out to thoroughly refurbish her. He did most of the work himself. Before he set sail from Marina del Rey on June 14, *Intrepid* had been re-rigged, re-powered and equipped with an impressive arsenal of cutting-edge navigation and communications gear, some of which was supplied by Zac's long list of corporate and private sponsors. The solo sailor and his family have hinted that they'd love to publish a book on his

continued on outside column of next sightings page



THE SUNDERLAND FAMILY

**Who will do it? Zac Sunderland . . .**

# SIGHTINGS

## teens — cont'd

trip, as Graham did, and perhaps even make a film about it. *Intrepid* carries several cameras.

Before his original departure, and again during stops in Hawaii and the Marshall Islands, Zac and his parents were interviewed by a wide variety of mainstream media outlets, including CNN and the *L.A.*



THE CLARK FAMILY

*Times*. The overwhelming majority of viewers and readers have been supportive of the attempt, despite some vocal detractors labeling Zac's parents as irresponsible for letting their child attempt such a potentially dangerous endeavor. But then, the naysayers probably aren't sailors, nor are they familiar with the magic of EPIRBs and AIS. The campaign's website, [www.zacsunderland.com](http://www.zacsunderland.com), receives thousands of hits daily, as Zac frequently updates his blog via SSB and satphone — he calls his shore base (aka Mom) every morning to give an update on his progress.

Although sailing a course similar to Graham, who also left from Southern California (in 1965), Zac is quick to acknowledge that, "Compared to Robin, my trip seems easy or at least a lot

... or Josh Clark.

safer!" Graham, he explains, "left with a VHF radio, sextant and at some point in the trip picked up a transistor radio. That was the extent of his electronics package." By contrast, *Intrepid* is equipped with "several GPS units, two radars, a chartplotter, two computers, a high frequency radio, a satphone . . . an EPIRB and a liferaft," not to mention the daily weather forecasting he receives via his Iridium satphone from Clear Point Weather. Nevertheless, it's still a very long way around the world for a 16-year-old, and Zac has the added pressure of having to make the trip at a much faster pace — less than two years, compared to Graham's five.

As if solo circumnavigating under time pressure wasn't stressful enough, Zac has another issue to worry about: a little-known 'competitor' named Josh Clark, who is also 16. Until recently, neither sailor was aware of the other. They both had a similar inspiration, although their campaigns are dramatically different.

Like Zac, Josh got his sea legs at an early age and has honed his seamanship skills through years of cruising (9 years, in his case) with his parents. When he took possession of his Cal 29, *Elusive*, in Panama three years ago, describing her as a fixer-upper would have been charitable. She was an abandoned wreck that the Balboa YC was thrilled to get rid of. Having welding, carpentry and fiberglass skills, Josh rebuilt the little sloop from stem to stern over the past three years, completely redesigning her interior with scrounged materials and gear. She now measures 32 feet. He financed the project with his savings and by doing odd jobs.

"I tried to build the best boat I could with the knowledge I have, and do it on as much of a shoestring as I could." Although he has no corporate sponsors nor well-heeled benefactors, he's received a variety of gear from supportive cruisers and through his own resourcefulness — he reports trading a fender for a used watermaker.

He too has a satphone, a nav computer and requisite gear such as an EPIRB and liferaft. And, although his shore support is miniscule compared to Zac's, he does have a website, [www.TheWaywardOdys-](http://www.TheWaywardOdys-)

continued on outside column of next sightings page

## ha-ha

Mexico; and 49% intended to sail for more than one season in Mexico and beyond.

4) Where do Ha-Ha skippers get their sailing information? Some 88% of them read *Latitude 38*, 51% read *Cruising World*, and 30% read *Sail*. The top five were rounded out by *Lats & Atts* at 17% and *Ocean Navigator* at 12%.

The most surprising comment — at least to us — was "the Grand Poobah gives the impression that he's tired of the Ha-Ha." Say what?! Perhaps we're going to need to review our demeanor, because that certainly isn't the case. While we do

**If any of your Southern California friends asks you what it's like to sail on the Bay in the summer, just show them this shot of a Folkboat squirting across The Slot.**





## — cont'd

get a little mentally and physically tuckered out on the the Ha-Ha — two weeks is a long time to go with so much to keep track of and so little sleep — but we're certainly not tired of doing and managing the event. In fact, we can't imagine ever not doing it.

To find out more about the 'Fabulous Fifteen' Baja Ha-Ha, go to [www.baja-haha.com](http://www.baja-haha.com). There you'll be able to sign up online or, if you're 'old skool', request an entry packet. But you'd better hurry as the entry deadline is September 10!

— richard

## teens — cont'd

[sey.blogspot.com](http://sey.blogspot.com).

While Josh is theoretically chasing Zac for the record, you could hardly call their efforts a race. Shortly after his departure, Josh had some gear troubles that delayed him so much in Costa Rica, that he's decided to stall his South Pacific departure until November or December. "My route is up in the air," explains the young adventurer. "I'm going to play it by feel, and head mostly west."

Time will tell how each of these gutsy singlehanders fares on his 27,000-mile odyssey. We certainly wish them both the best of luck, and will bring you updates in the coming months. If you're the praying type, you might want to say a little prayer for each of them. And if you're the toasting type, we suggest you raise a glass to them and wish them fair winds, following seas and a boatload of good luck.

— andy





---

PACIFIC CUP 2008





## — BLAST FROM THE PAST

**I**f your goal was to win your division in the 2008 Pacific Cup, you vastly improved your chances by having a boat designed more than twenty years ago. Six of the eight divisions were won by boats designed before 1985, including overall and Double-handed 1 winner, Joby Easton's immaculate Portland-based Cascade 36 *Rain Drop*.

Easton and navigator Bill Huseby sailed *Rain Drop* into Kaneohe Bay after 12 days, 2 hours, 54 minutes and 33 seconds, claiming overall honors in the 2008 Pacific Cup.

For Easton and Huseby, this Pacific Cup was a reunion of sorts — the two had sailed the race doublehanded in 1988, winning overall on Huseby's Sovarel 33 *Sting*.

In 2006, Easton realized the anniversary of their win was coming up, and Huseby was up for another go, as long as it was on Easton's tab. So the

***Spread—'Rain Drop' rolls into Kaneohe Bay on July 26 — overall winner of the 2008 Pacific Cup.***



COURTESY SLEEPING DRAGON

***Paul Martson, Debi Cohn, and Dean Daniels of the Hobie 33 'Sleeping Dragon' — second overall and first in Division D — still smiling halfway across.***

latter started looking at boats, and in December of '06 ultimately settled on the Cascade 36, designed by Portland naval architect Bob Smith back in 1967.

"The boats have a lot of history in Portland, and a lot of people feel that Bob Smith was ahead of his time," Easton said, adding that his four-year-old daughter Piper and wife Danielle played into the decision. "I wanted a total kid's boat, or a boat I could go cruising on afterwards."

The fact that several Cascade 36s



# PACIFIC CUP 2008



BOTH LATITUDE/ROB

**"There once was a girl in Hawaii" — opened Clare Waterloo's limerick-competition winner at the 5 o'clock follies . . . then it was something about waiting for her Division A-winning husband, Steve, and a peaking libido. Take the champagne bottle, Gene Simmons tongue, and fill in the blanks.**

have circumnavigated clinched the deal. The cruising cutter, which Easton purchased for a paltry \$15,000, needed a fair amount of work, and what followed was a big project.

"It was insanity," Easton said of the rehabilitation. "I'm not an engineer, not technical — I don't like fixing things."

With the support of his boss, Tom Garnier, with whom Easton won last year's TransPac overall on the Gar-



**Division C winner Mike Maloney lends a supportive hand to one of 'Bullet's key shore crew.**

nier family's J/125 *Reinrag*, Easton embarked on a major refit of the boat, enlisting the help of Portland-based pro sailor Caleb Borchers and a local yard to pimp his ride. All that prep paid off, as their biggest mishap was an exploded salt and pepper shaker.

And while Easton may not be an engineer, Huseby is, and a good navigator to boot — a complementary mix of skills that netted them the *Latitude 38* Performance Trophy for the best performance against their division, which they won by a 38 hours. For his efforts at the chart table, Huseby took home the Henri Lloyd Navigator's Award.

When a fleet of 61 boats starts over a six-day span, someone's bound to draw the short straw weather-wise. When the first three divisions that started the

2008 Pacific Cup on Monday, July 14 — Doublehanded 1, Division A and Doublehanded 2 — were met with near-drifting conditions that lasted until late in the afternoon on Tuesday, it sure looked like it would be them.

Sure enough, as Divisions B and C started that second day, they were almost immediately in the top overall spots.

Each successive morning roll call established this pattern as Divisions D and E got off in 20-30 knots of breeze on Wednesday, conditions they used to bomb south, staying clear of a North Pacific High that was anticipated to weaken.

Luckily for those first starters, including *Rain Drop*, everyone's fortunes were about to change.

For the first six days of their race, things weren't looking propitious for Easton and Huseby to repeat.

But a funny thing happened as Division F, the last one to start, charged off the line. While the big boats blasted south in a gale, the High was weakening a little bit farther west. The ridge extending to its southeast was strengthening, and all of a sudden, a certain *Rain Drop* had

fallen right into the overall lead.

Conventional wisdom would have it that you really don't start gybing a lot on this racetrack until you hit roughly the last third of the course.

This year was different. Most boats were gybing by the time they'd reached the halfway point and only peril awaited those who didn't.

*Doublehanded 2* — Sean Throwe and Neil Weinberg were looking to repeat after winning their division in the 2006 race aboard Throwe's perfect Swede 55 *The Contessa*. But the lack of any really serious reaching — many boats had kites up on day two — meant that the bright-red



LATITUDE/JR



LATITUDE/ROB

**Sarah Deeds and Andy Hamilton sailed his Moore 24 'Barba-loot' to a seven-hour win in Doublehanded 2.**



## — BLAST FROM THE PAST

sliver with nearly as much overhang as waterline never really got to stretch her legs.

"There's two things I hate about this race," Weinberg joked as he relaxed on the boat after the race, "Moore 24s and Cal 40s."

As if he needed any more of reminder, *The Contessa* was surrounded by Cal 40s and Moore 24s on the Kaneohe YC bulkhead.

One of the Moores — designed and developed from 1967 to 1972 — was Andy Hamilton's Santa Cruz-based *Bar-*

*Golden Oldie* — at almost 50 years old, *'Sabrina'* proved she can still handle the new kids on the block, winning in the competitive Division E.

*ba-loot*. Hamilton had recruited Berkeley architect and 505 and Vanguard 15 sailor Sarah Deeds for the trip and the two crushed their division. They made an early move south after keeping division rivals Mark A. Moore and Rowan Fennell on *Moore Havoc* close, well to the north of rhumbline for the first few days of the race.

With the aid of a proprietary routing software developed as a lark by a friend, Hamilton put the boat where it needed to be, diving south.

By the sixth day of their 12-day, 23-hour and 19-minute passage, Hamilton and Deeds were leading by a couple hours, and extended to more than seven



LATITUDE/ROB

**The Mad Repairmen** — Geoff Ashton and Grant Donesley show off their tiller fix aboard 'Checkered Past' which was good enough to keep owner Chris Gibbs driving for the 'Best First Passage Trophy' and Division B win all the way to Hawaii.

by the next closest finisher — the second place Express 27 *Alternate Reality* sailed by Darrel and Duane Jensen. Sitting on 13-14 knots of boatspeed in a massive squall and winning Doublehanded 2 were welcome rewards for the preparation involved for doing the race, but there was another.

"It was pretty cool," said Hamilton, an engineer at the Monterey Bay Aquarium Research Institute. "I didn't think about anything other than sailing the boat the entire time. When do you get to do that?"

**Division A** — At the 100-mile check in, the crew of Steve Waterloo's Cal 40 *Shaman* — designed back in 1963 — decided that no matter what happened, they had to finish the race that day. So they reported their finish-line ETA as 23:59 on July 26. Despite a light patch 15 miles from the finish, they crossed the line at 23:47, taking what was one of the tightest divisions in the race.

The entire way across, *Shaman*, Jim Quanci and Mary Lovely's Cal 40 *Green Buffalo*, Rodney Pimentel's Cal 40 *Azure*, James Partridge's Cal 2-46 *Gaviota* and Timm and Victoria Lessley's Cal 40 *California Girl* had been engaged in what





# PACIFIC CUP 2008

LATITUDE/ROB



**She's a wet one!** — The pussycats and their 'Criminals'. Crewmember Ty Reed described it as, "taking a submarine across the Pacific." No wonder the boat's mascot is a soggy kitty. The reward? 'Criminal Mischief' sustained speeds in the low 20s en route to winning Division F — meow. . . .

resembled a buoy race, with less than five hours separating them for most of the race.

"We sailed within sight of *California Girl* for 96 hours at one point," Waterloo said. "Finally, we waited until Family Hour before gybing to lose them."

*Shaman* anchored the Encinal YC team — rounded out by *Azure* and John McCartney's Nordic 44 *Music* — that took home the Storm Trysail Club Team Trophy, and *Shaman's* crew came straight from the pages of the club's roster and including junior staff commodore Tony Shaffer, Paul Sinz, Larry and Addison Duke.

**Division B** — Chris Gibbs' Wyliecat 39 *Checked Past* was the wire-to-wire winner in this division. A couple days out from San Francisco, two D-rings on the wishbone boom that create outhaul tension failed, requiring navigator Geoff Ashton to climb the rig and effect a repair in 30 knots of breeze. Then, farther across, their tiller exploded. Ashton and Grant Donesley fashioned a splint with some wood battens and a banding tool they'd brought along to splint the boom if needed.

The 'broken boat' sailed to an impressive win — managing to keep their lead even through the later downwind stages of the race when the lack of a kite meant they were giving some back to the division.

As far as we know, Gibbs is the first paraplegic to win his division in the Pacific Cup — and definitely the first to do it with two cancer survivors, father

Larry and longtime friends Geoff Ashton and Grant Donesley, a multiple stroke survivor, as crew. You can find the backstory in July's *Latitude 38* Pacific Cup Preview. It was also the crew's first trip, and their performance won them the Best First Passage Trophy.

**Division C** — One of the great match races in the Pac Cup was between Dean Treadway's *Sweet Okole* and Mike Maloney's Express 37 *Bullet* in this division.

"We were in sight of each other until day five," Maloney said. "Occasionally, they'd disappear for a little while and then they'd be back in sight."

The fractionally-rigged *Okole* seemed to have the edge in the earlier, reachier part of the race, but when the two finally split, with *Okole* headed north and *Bullet* — designed back in 1985 — headed south, the edge was reversed.

"When we got over 20 knots of breeze and were sailing downwind the last four days, we really got going," Maloney said.

The southerly option that Maloney chose turned out to be the winner, as *Okole* got stuck in lighter breeze to the north, and *Bullet* cruised to the division win and 4th overall.



DAVE KEANE

"[Mike] made a huge tactical decision to dive south," said *Bullet* crewmember Leif Wadleigh, who along with Dave Parker, Brent Draney and Tom Pauling



## — BLAST FROM THE PAST



Jody Taliaferro and Skip McCormack (left) tied the knot on the Kaneohe Bay sandbar after taking their honeymoon on a wild ride across the Pacific aboard the TP 52 'Flash'. Crewmember Will Paxton said the off-watch would come on deck as the boat charged through squalls — to cheer. Sounds like fun.

rounded out the crew. "That was a really tough call — the gibs said south and the routing said south, but our competition was going north."

**Division D**— Dean Daniels' *Sleeping Dragon* was at the head of the class in this division, which, in turn accounted for three of the top five spots overall. The turboed Hobie 33 — designed in 1981 — that Daniels bought last year specifically for this race turned out to be just the weapon he needed to win his division and place second overall with longtime sailing buddies Paul Martson and Debi Cohn.

"A friend likened racing a turbo Hobie

33 in the Pac Cup to bringing a gun to a knife fight," Daniels said, adding that many of the improvements came with the boat.

Tactically, *Sleeping Dragon* was as far south as anyone for almost the entire race, and it paid big — for awhile, they were leading the race, trading the top spot with Paul Cayard's SC 50 *Hula Girl*. The decision to go that way wasn't entirely scientific though.

"We looked at the 96-hour model the day of the start and picked a point where it looked like there was a knuckle in the wind barbs as our ridge crossing point," Daniels said. "Then at sundown the second night we decided we couldn't

go another nine hours without the kite up. That night was when we clocked our highest speed — 19.3 — while I was driving in the pitch black before the moon came up. We ended up sailing 160 miles south of our original ridge crossing point. Of course, we had no clue what our polars were supposed to be, but the fun in surfing the boat more than matches the stress of doubting whether you're going fast."

**Division E**— For Paul Cayard, sailing this year's race with his kids Danny and Allie was a "dream". His turboed SC 50 *Hula Girl* sailed a 9-day, 1-hour and 30-minute passage to take third in division, after having led much of the race.

At the dock in Kaneohe Bay, they waited to see what kind of breeze the slower boats in the division would bring with them to the finish. A day and a quarter later, Ken Olcott's Schumacher 39 *Recidivist* rolled in, trouncing *Hula Girl* by 20 minutes.

Another day later, Chris Calkins and Norm Reynolds' *Sabrina*, navigated by Fred Delaney, rolled into Hawaii, correcting out to a division win by under an hour and a half.

If you were walking the dock and didn't know what you were looking for, a nearly 50-year-old double-ender with fish flags flying above the large pilothouse, copious brightwork and a pushpit-mounted barbecue would probably not register as 'the boat that beat the boat that beat the only Volvo Ocean Race veteran in the division'.

If sailing the race was the realization of a "dream" for Cayard, then for Calkins it was the realization of a 'dream deferred'. His father Skip designed the boat in 1958. Nine years later the elder Calkins invited his son — who was preparing to go off to law school — to sail in the TransPac. He declined the invitation, thinking that "I'd just do the next one." A career took over before that could happen, but the desire to sail the race never abated. "I always felt bad about not doing it."

Fast forward to 2007. Calkins owned a sistership, *Kathleen*, and wanted to do the race. He and a third boat partner who didn't sail this race, designer Doug Peterson, looked at updating her appendages but established that it would be too costly. Serendipitously, *Sabrina*, known at the time as *Ginny*, was on the market, and her owner had made the changes they'd wanted. Along with Reynolds, a veteran of five TransPacs, they purchased the boat.

"He's the guy," Calkins said of his

LATITUDE/ROB



# PACIFIC CUP 2008

Reynolds. "He's the skipper, and the one responsible for this." Their first outing ended in an early exit from the slow 2007 Transpac, but by the time March of 2008 rolled around, the classic yacht had racked up an overall win in the Corona Del Mar to Cabo Race. The group stayed on that roll all the way to Kaneohe Bay, and had probably one of the more commodious trips of the race.

"It's a cruise boat," Calkins said, as crewman James Sakasegawa's extemporaneous fish flags fluttered overhead. "It seems like yacht racing has gone in a direction of professionalism. It's less about the experience and the voyaging. We had a great trip, we caught seven mahi mahi and had five cases of wine on board — but we were still doing a consistent 12-15 knots with the spinnaker up."

In addition to those four, John Laun, Steve Malowney and David Servais rounded out the *Sabrina* gang.

**Division F** — *Criminal Mischief* is not your ordinary 45-ft IRC-oriented raceboat. The all-carbon, Reichel/Pugh-designed speedster might well be the fastest 45-foot monohull in the world offshore.

Owner Chip 'Dr. Megadeath' Megeath — so dubbed by the gang of miscreants he assembled for the race, is not your conventional big boat owner. When the 'Criminals' arrived in Hawaii, Megeath was sporting a 'do-rag and boxer shorts. Let's just say he's definitely not of the

blue blazer and breton-red trousers camp.

His path to a division win in this year's Pacific Cup is also not so typical. Sixteen years ago, other interests, a career in finance and raising a family took the former wooden boat sailor away from the water.

But last year, with the help of '06 Pac Cup winning navigator Jeff Thorpe, Megeath chartered Lani Spund's turboed SC 52 *Kokopelli*?, with which they finished second overall in the '07 TransPac while posting the fastest elapsed time of any boat under 60-feet.

"I'd never done a Transpac and always wanted to," Megeath said. After a season of sailing the boat, including the Coastal Cup and Spinnaker Cup, he was hooked again.

In the market for a boat with his charter soon to expire, he and Thorpe found the year-old *Criminal Mischief*, known then as *Beau Geste*, in Melbourne, Australia. They closed the deal in February and were sailing the St. Francis YC's Stone Cup in May, where they won their division. Megeath isn't feeling any buyer's remorse either.

"The boat is great — it reaches every bit as fast as the big boats," he said. "The bow will find its way down waves — it bears you off by itself when you'd already

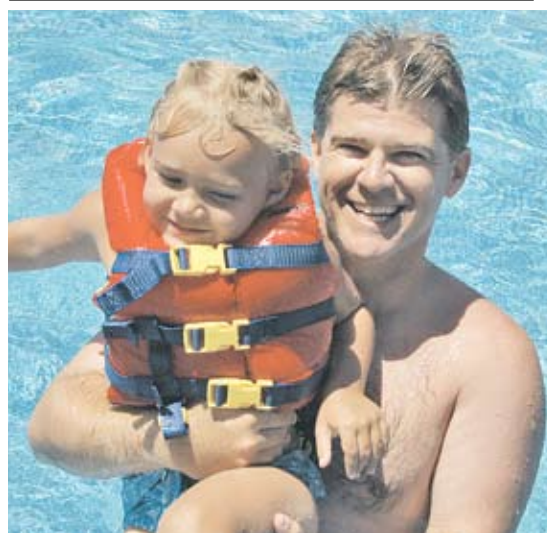

LATITUDE/ROB

**'Rain Drop'let** — Four-year-old Piper Easton gets some pool time with dad Joby at Kaneohe YC.

want it to, and it'll give you warning and a second chance if you start to push it too hard."

Megeath and Thorpe rounded up an experienced gang for the crossing, including Ian Klitza, Robin Jeffers, Brendan Busch, Patrick Whitmarsh, Campbell Rivers and Ty Reed.

"They're a blast," Megeath said. "They're great sailors and a lot of fun to sail with."

"I'm jaded on keelboat sailing for life after this," said Reed. "At one point Campbell was driving and the boat was sailing at a sustained 22- to 24 knots for over a minute."

Rivers was also credited with a find that probably saved their race, when he noticed the gooseneck pin working its way out. Apart from that, the vang becoming detached momentarily, and having to back down to clear a fishing net, the 'Criminals' had a fast, albeit wet, crossing.

"We took a submarine across the Pacific," said Reed.

Elsewhere in Division F, Philippe Kahn and Richard Clarke sailed a remarkable race on Kahn's unruly Open 50 *Pegasus OP-50*, sailing doublehanded. They finished with a remarkable elapsed time of 7 days, 15 hours and 7 minutes, beating the previous doublehanded race record by more than a day.

Steve Rander's Wylie 70 *Rage*, the scratch boat in the fleet, lost the the top six feet of its rig a few hundred miles from

**Right, Pac Cup freshman Tony English got a crash course on the 'band-it' tool aboard 'E.T.', below. Todd Hedin's Antrim 27 finished third in Division D and fifth overall despite breaking their bowsprit and spare, before making a truncated one.**



BILL MYERS/CIRRUS



LATITUDE/ROB



# — BLAST FROM THE PAST

the finish and was reduced to sailing with a reefed main and fractional kites the rest of the way.

Continuing what's become sort of a tradition in the race, Skip McCormack and Jody Taliaferro — who sailed on the TP 52 *Flash* — made it their honeymoon. Their special twist was that they actually tied the knot *after* the race — on the Kaneohe Bay sandbar.

*Close encounters of the cetacean kind* — *Green Buffalo* was one of three boats to hit a whale during the race.

"We were 300 miles out, in the middle of a beautiful afternoon doing about 11 knots in 22 knots of breeze," Quanci said. "I was down below and heard a 'BANG. . . BANG. . . bump, bump, bump. The boatspeed went down to 2-knots and the steering went stiff. I came up on deck and looked back and 40-ft sperm whale surfaced in our wake, turned and started following us."

The dazed whale dropped its pursuit shortly thereafter, and a thorough check of the boat revealed no damage — other than a spooked crew and stiff steering — but left Quanci wondering if he'd jinxed them by reading *Moby Dick* while sailing the boat home after the '06 race.

"The whole crew got real quiet," Lovely said. "When we finally did start talking after about an hour, all that was said was about what we'd take if we had to abandon ship."

Phil Mummah's Gibsea 43 *No Ka Oi* and *Checkered Past* — which had a pilot whale come alongside for a little bump and grind — were the other two whale encounters we were able to confirm.

*Family business* — Along with their third overall, Dave Rasmussen's Synergy 1000 *Sapphire* claimed two other trophies: the Carl Schumacher Trophy for the top Schumacher-designed boat, and the *Bluewater Sailing* "Fastest Family Afloat" Trophy.

The other Rasmussen aboard was Dave's son David, a 49er sailor who, at the tender age of 21 already has three Pacific Cups under his belt. His first came when father and son sailed together doublehanded in the '04 race on an Express 27, and the second, when mother and daughter decided they wanted to join in the fun too, prompting Dave to buy *Sapphire* as a bare hull and deck and finish her off in time for the '06 race.

"Dave made some great calls," said Phil 'entertainment committee' Krasner,

## DOUBLEHANDED 1 (Started Monday, July 14, 12:50)

1	1	<i>Rain Drop</i>	Cascade 36	Joby Easton/Bill Huseby
2	39	<i>Plus Sixteen</i>	Olson 911	Paul Disario/Tony Porche
3	46	<i>Giant Slayer</i>	SC 27	David Garman/Debra Lowell
4	48	<i>Rubicon III</i>	Contessa 33	Rod Percival/Chris Laubach
5	58	<i>Dart</i>	Peterson 34	John Crutcher/Patrick O'Connor
DNF*		<i>Neptune's Daughter</i>	Pac. Scrft. 34	Earlinda/Edward Polkenhorn

## DOUBLEHANDED 2 (Started Monday, July 14, 13:20)

1	7	<i>Bar-ba-loot</i>	Moore 24	Andy Hamilton/Sarah Deeds
2	22	<i>Alternate Reality</i>	Express 27	Darrel/Duane Jensen
3	30	<i>Moore Havoc</i>	Moore 24	Mark A. Moore/Rowan Fennell
4	31	<i>Le Flying Fish</i>	Moore 24	Stephane Plihon/J.P. Sirey
5	42	<i>Mirage</i>	Express 27	Terry/Steve Cobb
6	45	<i>Moonshine</i>	Dogpatch 26	Dylan Benjamin/Orlando Montalvan
7	50	<i>The Contessa</i>	Swede 55	Sean Throwe/Neil Weinberg
8	54	<i>Elise</i>	Express 27	Nathalie Criou/Nathan Bossett

## DIVISION A (Started Monday, July 14, 13:05)

1	11	<i>Shaman</i>	Cal 40	Steve Waterloo
2	14	<i>Green Buffalo</i>	Cal 40	Jim Quanci
3	17	<i>Azure</i>	Cal 40	Rodney Pimentel
4	23	<i>California Girl</i>	Cal 40	Timm/Victoria Lessley
5	24	<i>Gaviota</i>	Cal 2-46	James Partridge
6	29	<i>No Ka Oi</i>	Gibsea 43	Phil Mummah
7	36	<i>Valis</i>	Pac. Scrft. 44	Paul Elliot
8	52	<i>Acacia</i>	Valiant 42	Bob Hinden

## DIVISION B (Started Tuesday, July 15, 13:30)

1	8	<i>Checkered Past</i>	Wyliecat 39	Chris Gibbs
2	16	<i>Music</i>	Nordic 44	John McCartney
3	27	<i>Cirrus</i>	Standfast 40	Bill Myers
4	37	<i>Kokomo</i>	Sabre 425	Denny Flannigan
5	47	<i>Gavilan</i>	Wylie 39	Brian Lewis
6	51	<i>Compromise</i>	Elite 37	David/Sandy Englehart
7	56	<i>Pacific High</i>	Catalina 400	Andre Skarka
8	59	<i>Horizon Hunter</i>	Hunter 46	Charlie Cooper

## DIVISION C (Started Tuesday, July 15, 13:45)

1	4	<i>Bullet</i>	Express 37	Michael Maloney
2	15	<i>Sweet Okole</i>	Cstm. Farr 36	Dean Treadway
3	25	<i>Bequia</i>	Beneteau 411	Dennis Ronk
4	26	<i>Tiki Blue</i>	Beneteau 423	Gary Troxel
5	41	<i>Urban Renewal</i>	J/35	Les Vasconcellos
6	44	<i>Oceanaire</i>	Tayana 47	Garrett Caldwell
7	49	<i>Ada Helen</i>	Catalina 42	Joseph Pratt
8	55	<i>Rabian</i>	J/35	Vern Zvoleff

## DIVISION D (Started Wednesday, July 16, 14:10)

1	2	<i>Sleeping Dragon</i>	Hobie 33	Dean Daniels
2	3	<i>Sapphire</i>	Synergy 1000	David Rasmussen
3	5	<i>E.T.</i>	Antrim 27	Todd Hedin
4	18	<i>Summer Moon</i>	Synergy 1000	Joshua Grass
5	28	<i>X-Dream</i>	X-119	Steen Moller
6	35	<i>J-World</i>	J/120	Wayne Zittel
7	40	<i>Ohana</i>	Beneteau 45f5	Dean S. Hocking
8	43	<i>Jamani</i>	J/120	Sean Mulvihill
9	57	<i>Buzz Off</i>	Henderson 30	Tom Fischer/Linda Rodriguez

## DIVISION E (Started Thursday, July 17, 14:45)

1	9	<i>Sabrina</i>	Calkins 50	Chris Calkins/Norm Reynolds
2	10	<i>Recidivist</i>	Schumacher 39	Ken Olcott
3	13	<i>Hula Girl</i>	SC 50	Paul Cayard
4	19	<i>Morpheus</i>	Schumacher 50	Jim Gregory
5	32	<i>XL</i>	Antrim 40	Barran Family
6	33	<i>Low Speed Chase</i>	Sydney 38	James C. Bradford
7	34	<i>Roxanne</i>	J/125	Greg Slyngstad

## DIVISION F (Started Saturday, July 19, 15:50)

1	6	<i>Criminal Mischief</i>	R/P 45	Chip Megeath
2	12	<i>Velos</i>	Tanton 73	Kjeld Hestehave
3	20	<i>Holua</i>	SC 70	Brack Duker
4	21	<i>Flash</i>	Farr TP 52	Mark Jones/Dick Watts/Peter Stoneberg
5	38	<i>Pegasus OP-50</i>	Owen/Clarke 50	Philippe Kahn/Richard Clark
6	53	<i>Rage</i>	Wylie 70	Steve Rander

who rounded out the crew along with the younger Rasmussen's 49er crew John Gray. Prior to the race Gray apparently didn't fully appreciate what kind of

rocket he'd be riding across the Pacific. "It's a tough boat to sail competitively around the Bay," the elder Rasmussen said. "But it's is an awesome boat out on

# PACIFIC CUP 2008

the ocean. We would be sailing 13, 14, 15 knots sustained — not surfing waves but skipping them — John was surprised."

Nearly twenty boats — a third of the fleet — qualified for the family trophy. One, Kjeld Hestehave's Tanton 73 Velos, had three father/daughter combos. *Green Buffalo* had Quanci and Lovely's two sons aboard, and Richard Barran celebrated his 13th birthday aboard his family's Antrim 40 XL, which featured three generations with father Antony and grandfather Nick.

One popular 'family' activity was the daily "family hour" and its master of ceremonies, the race's communications chairman Michael Moradzadeh, who got glowing reviews from everyone we spoke with.

Ultimately, the race really seems to live up to its billing as the "fun race to Hawaii," probably due in part to the fact that you can bring a well-prepared 40-year-old-design, or an ultra-modern year-old boat and take home some crystal if you point it in the right direction and sail it hard.



JIM GREGORY/MORPHEUS

**Mid-ocean Apocalypse Now-style freakout? No, just Jonathon Livingston winning the "ugly Hawaiian shirt competition" aboard 'Morpheus.' Remember last month's Interim Report and the reference to, "shamelessly shaking their junk?"**

Another factor in the 'fun' equation is the family element. And it's not just the families who are competing, but the

extended family of volunteers on the mainland and at Kaneohe YC. Sometimes volunteer-staffed events tend to become old for the volunteers after years of hosting them, and it's reflected in the welcome, or a lack thereof.

Nothing could have been farther from that scenario with the Pacific Cup. At Kaneohe YC, everyone we met seemed genuinely happy to play host. Pretty soon, it became apparent that the resurgence of entries, into the 60s this year, from the 2006 count of 41, was no fluke.

There were — and are — many more stories of the 2008 Pacific Cup. We wish we could tell them all. But even if we removed all the photos from this article, we'd still only be scratching the surface.

But the advent of the 'racer's blog' means you can get a lot of the one's you missed on your own. Just visit [www.pacificcup.org](http://www.pacificcup.org) for full results, links to the boat blogs and more. Oh, and, put this event on your calendar for 2010.

— Rob



## Prepare for the unexpected

### BLUESTORM



Bluestorm Inflatable PFDs provide the ultimate in style, safety and value.

- Three sailing models with built-in harness
- Manual, fully automatic, or convertible inflation
- USCG approved

Bluestorm  
P.O. Box 210  
Plymouth, MA USA  
(877) 688-5657  
[www.bluestorm.us](http://www.bluestorm.us)



## LIFELINE®

the heart of your system

Crafted for quality in the U.S.A.

### MARINE BATTERIES

The original AGM manufacturers for the Marine and RV Industry



- Sealed, Pressure Relief Safety Valves**  
Operates in any orientation without leaking  
Maintenance-free; never requires water additions
- Lifting Handles**  
Easier handling, carrying & installation
- Copper Alloy Terminals**  
Provides low resistance electrical connection (copper-to-copper), non-corrosive.  
Increased environmental protection & personal safety — no exposed lead
- Reinforced Copolymer Polypropylene Container & Cover**  
High impact resistance and resists bulging even under severe overcharge and temperature
- Absorbent Glass Mat (AGM) Separator**  
Custom designed and manufactured to provide superior wicking characteristics for electrolyte retention
- Thick Plates and High Density Oxide Paste Materials**  
Insures long life, excellent cycling capability
- Polyethylene Envelope**  
Eliminates internal shorts caused by shock, vibration & dendrite growth
- Cover-To-Container Seal**  
Strong, epoxied tongue & groove cover/container seal will not separate even under extreme temperature & pressure changes or vibration
- Intercell Connections**  
Massive "over-the-partition" weld increases the weld strength & provides low resistance connection path

To learn more about Lifeline Batteries contact us or visit our web site at:

**LIFELINE BATTERIES, INC.**  
955 Todd Ave.,  
Azusa, CA 91702  
800-527-3224  
<http://www.lifelinebatteries.com>

Lifeline, a pioneer in AGM technology was originally developed in 1985 for military aircraft. Lifeline series of maintenance free deep cycle batteries that has been the leading AGM battery in the Marine and Motor Coach Industry for the past 15 years.



# We put you on a silver platter.



*"The Raceware Specialists"*

[www.APSLTD.com](http://www.APSLTD.com)

800.729.9767

**REPAIR  
REPAIR  
REPAIR**

**ROOSTER SAILS  
A REPAIR LOFT**

• CRUISERS' REPAIRS  
• FAST TURNAROUND  
• RACING REPAIRS

**YOUR ROLLER  
FURLER UV COVER  
SPECIALIST**

**ROOSTER SAILS**

451 West Atlantic Ave., Alameda Pt. (Alameda Naval Air Stn.)  
**(510) 523-1977**

[www.roostersails.com](http://www.roostersails.com) • [rui@roostersails.com](mailto:rui@roostersails.com)

Open M-Th 9-6 • Fri 9-5 • Sat by appt.

Owned and Operated by Rui Luis • Experienced Sail Repair and Fabrication

**NOW OFFERING NEW CRUISING SAILS!**

**SAIL REPAIR SPECIALISTS • COMPETITIVE RATES • RECUTS • CONVERSIONS**

**Port Townsend  
Shipwright's Co-op**

**Celebrating our 25<sup>th</sup>  
Anniversary!**

*The oldest boat yard in Port Townsend!*

**360-385-6138 800-567-8780**

[www.ptshipwrights.com](http://www.ptshipwrights.com)

# THE KING HARBOR RACE

There was some unwanted excitement during the 36th annual 81-mile race from Santa Barbara to King Harbor on August 1, as two women went overboard from the Antrim 27 *Rattle & Hum*, and three men found themselves

collectively done eight TransPacs and countless Mexico races, so they are not novices. Furthermore, Sue and her husband Barry are having a new Antrim 40 box rule boat built that the Nauti Chicas

will be racing in next year's TransPac.

Flying the light *Rattle & Hum's* biggest chute in 25-knot winds with gusts to 31 knots, and after hitting speeds of over 16 knots, the boat rounded up violently: so violently that helmswoman Senescu and trimmer

an estimated two miles astern. Crowfoot quickly put out a dramatic call to the Coast Guard on 16 to advise them that one of their crew was still overboard and no longer in sight. To complicate things, neither of the women who had stayed aboard the boat after the knockdown had been able to push the MOB feature on the GPS belowdecks until Senescu was back aboard, meaning the MOB position was more than a mile off Karlsen's actual position.

Karlsen told *Latitude* that she was tangled in lines that kept her pinned beneath *Rattle & Hum* right after going overboard at about 7:15 p.m. As *Rattle & Hum* continued to move forward rapidly — Karlsen estimates it at what would seem to be an impossibly fast 11 knots — she was engaged in a "life and death struggle" gasping for air. Initially she got free enough to reach the surface, but continued to have trouble breathing. After what Karlsen felt to have been a quarter mile, she decided she had no choice but to let go. With *Rattle & Hum's* big spinnaker still flailing, and with the boat still on her side, the boat rapidly left Karlsen in her wake. Miles from land, she had to be feeling very much alone.



Once they got near Anacapa, 'Pendragon II', 'Malolo', and the rest of the fleet began to pick up a little breeze on a tight reach.

standing on the overturned hull of the Corsair Sprint 750 *Existential Blowout*.

The women overboard incident in the 107-boat fleet was potentially the most serious, as one of them, Judy-Rae Karlsen of Long Beach, ended up swimming in the open ocean for approximately 30 minutes without a PFD. Fortunately, her prayers were answered just before dark, as she was miraculously spotted and picked up by another racing boat. There had been a near-death experience on the trimaran, too, as crewman Terry Lindemann came within an instant of drowning as a result of being trapped beneath the flipped boat.

As is common in the King Harbor Race, there had been very light winds until just before the fleet

rounded the turning mark of Anacapa Island. It was between Anacapa and Pt. Dume where the wind piped up and the two boats had their problems.

Karlsen was one of four women — Sue Senescu, Betsy Crowfoot and Valerie Navarro being the other three — racing aboard Senescu's Antrim 27. Calling themselves the 'Nauti Chicas', they've

Karlsen were pitched across the boat and into the water. With *Rattle & Hum* pinned on her side — a position she would remain in for another 10 minutes or so — Crowfoot kicked the MOB device in an attempt to launch it. But because the boat was heeled over so far, it didn't launch. She then rushed to the other side of the transom and threw the horseshoe buoy to Karlsen. Crowfoot was then faced with the terrible decision of whether to try to save Senescu or Karlsen. She told *Latitude* that she decided to try to save Senescu because Karlsen didn't seem as panicked. Indeed, Karlsen said "I'll

be okay", as the two women still onboard devoted their attention to trying to get the chute down and get Senescu back aboard.

Unfortunately, Navarro was unable to get the spinnaker down right away, and Crowfoot was unable to get Senescu

back aboard, and everyone was losing her strength. After another five minutes or so, Crowfoot resorted to tying a big bowline around Karlsen's upper torso, after which she and Navarro successfully 'womanhandled' Senescu back onto the boat. By the time they succeeded, Karlsen, who, like the others hadn't been wearing a PFD, was out of sight



Judy-Rae Karlsen is bookended by Judy and Dr. Bill Webster, the modest couple whose boat rescued her.





# A LITTLE OVERBOARD WITH EXCITEMENT

PHOTOS BY CHERIE SOGSTI, HEATHER CORSARO, AND LATITUDE/RICHARD

During the 20 to 30 minutes that Karlсен swam in the fading light, she saw two boats pass within what she estimates was about 10 boat lengths. Neither saw her or heard her desperate calls for help. With darkness and her body temperature falling, she began to pray hard for a miracle. Her prayers seem to have

*Crowfoot was faced with the terrible decision of whether to try to save Senescu or Karlсен.*

been answered, for at that time, and for no particular reason, Dr. Bill Webster of the King Harbor YC-based J/37 *Sidekick* had gone below and switched the VHF radio on to channel 16. When he did, he heard the crew of *Profligate* advising the Coast Guard that they'd picked up two of the three crewman from the overturned trimaran *Existential Blowout*, and that they were about to go back for the third. It was then that Crowfoot, battling panic, broke in to report that *Rattle & Hum* had

**Spread; 'Malolo' stands by the flipped 'Existential Blowout'. Inset; The three Texans, Demetri, Mike, and Terry, will be back to race again.**

lost one of her crew overboard a distance back up the course, and that they weren't able to head back and search for her yet.

Webster quickly realized that his *Sidekick* was near the reported position of the woman overboard, and alerted the crew. "There she is!" one of them soon cried out. In an estimated 23 knots of wind, the *Sidekick* crew quickly doused the spinnaker, then the main, and turned on the engine. They missed Karlсен on the first pass, but got her with their Lifesling on the second. It had taken them about 10 minutes from the time they saw her to the time they picked her up. While the conditions weren't terrible, the rescue was an excellent example of seamanship.

"I'm alive and safe today because of the people on *Sidekick*," Karlсен later said. The only unfortunate thing — and we're talking about nothing compared to a human life — is that the rescue meant that Webster's record of 18 straight finishes in the race was broken. Given that parts of the King Harbor Race — the start and Santa Monica Bay at night — often feature exasperatingly light air, it was quite



**With the crews rescued from the Antrim 27 and Corsair 750, other boats in the fleet, such as the 1D-35 'Deja Vu', continued racing.**

a record.

Despite her long and lonesome swim in the ocean, Karlсен looked calm and collected when we chatted with her at the King Harbor YC about five hours after her swim. She spoke about the incident in a surprisingly matter-of-fact-manner and seemed absolutely none the worse for the wear. *Sidekick* owners Bill and his wife, Judy, who were also at the club, tried to play down the role they played, saying that their crew deserved all the credit. Baloney! There is no doubt that Andy Zimbaldi, Chris Sellars, Jake Adams, Ken Kalenik, Mike Morgan, Marty Falk and Don Currie all played critical roles in the rescue, but it still took a captain to drive the boat and lead the team.

Mistakes made? The gals admitted to not having their PFDs on in windy conditions, noting they were just about to put them on. Crowfoot vows she'll never sail again without a very sharp knife handy with which to cut a spinnaker halyard or sheet to quickly lose a chute. In addition, the women also felt they'd probably waited a little too long — as is common for sailors — to reduce sail. But it was about to get dark, at which time the wind usually dies at that stretch of coast. Perhaps the biggest lesson they learned was the importance of not getting intoxicated — by boat speed, that is. "We were mesmerized by the need for speed," said Senescu. "The thrill was addicting."





# THE KING HARBOR RACE



**In this particular instance, a Carib dinghy on a long line, allowed to be blown down to the tri, proved to be an effective rescue device.**

Despite the just-cheated-death experience, the four women gathered on *Rattle & Hum* the next day to deliver the boat to Dana Point, all of them still eager to do the TransPac on Senescu's hot new Antrim 40.

About 15 minutes before Karlsen and Senescu had gone overboard, and a little further down the course, Texans Mike Maloney, Terry Lindemann, and Demetri Macris had a problem of their own with *Existential Blowout*. Maloney, who owns "five or six sailboats," including a cruising cat in the Med, and who is building a racing trimaran, had trailered the amped-up Corsair 750 to the West Coast earlier in the year in order to do a half dozen ocean races. Lindemann, a photographer and cameraman, had sailed with Maloney for about three years, while it was the first race for vascular surgeon Macris.

Unfortunately, it was the novice Macris who was at the helm when *Existential Blowout*, which had been doing up to 16 knots, took off down a steep wave. Lindemann remembers the rudder as coming "four feet clear of the water", and therefore being useless. When nobody eased the main quickly enough, the tri tripped over the leeward and main hulls. While his crewmates were thrown clear, Lindemann found himself, like Karlsen would be, in a life and death struggle.

"I was blasted into the mast with my

upper body, and was rolled around it like a rag doll," he remembers. "Meanwhile, the other crew were launched into the sail, which was now lying on the water. The trimaran then rolled on top of me in what seemed like 2.5 milliseconds. 'Holy shit!' I said to myself, and down we went, the boat on top of me. In a split second the auto-inflating lifevest went off like it was supposed to, which unfortunately kept me pinned against the boat above me. With less than a good breath of air, I did my best imitation of free diver Jacques Mayal to see how long the air in my less-than-full lungs would last. My first plan in the dark, cold Pacific water was to try and make it to the cabin, but I was afraid it might be full of water and have no air. So I opened my eyes and scanned the water for great white sharks that

patrol the area. Trying to keep my panic to a minimum while freeing myself from the tangle of lines, with gear floating all about the boat, I noticed some light.

"I decided to work my way toward the light, hoping I would reach it before my air was gone. But the inflated lifevest made it difficult to move. I reached for



**Size does matter. Because there is less margin for error, more small boats flip and/or lose crew overboard than do large boats.**

my knife to puncture the vest, but I'd given it to Demetri earlier. The buildup of carbon dioxide in my lungs was starting to make me grunt. From my scuba training 30 years ago, I knew you get about four grunts before you have to have air. 'Shit', I thought to myself, 'this is it for me!' But I suddenly caught the traveller, and strained to get through a gap of about 18 inches in the direction of the light. I pulled myself through as hard as I could, and although I slammed my head into the outboard, I finally made it out. Gasping for air, I looked for Mike and Demetri, who were splashing around trying to climb aboard the overturned hull. Maloney looked at me and said, "I





# A LITTLE OVERBOARD WITH EXCITEMENT

think I need a bigger boat."

"I'm very fortunate to be writing this,

*"I knew you get four grunts before you have to have air. I thought it was 'it' for me."*

but it was just not my time to go. I've had some post-crash anxiety incidents and flashbacks, but I'll soon be helping getting the tri ready to race again on the Pacific."

Fortunately for the three Texans, Bob Locke's Kernan 55 *Malolo* had been just behind them, and her crew had either seen the tri flip or saw her upside down shortly after the flip. The *Malolo* crew dropping their chute and main, and made us on *Profligate* aware that the tri had flipped, so we quickly doused our spinnaker and rushed to the scene under main alone. *Malolo* and *Profligate*

**What a difference a lee makes. Spread; three boats next to Anacapa in the lee of Santa Cruz Island. Inset; 'Lugano' just before the lee.**

circled the distressed trio to make sure everyone was accounted for and in reasonably good condition. The three crew, in no immediate danger standing on the buoyant tri, replied that they wanted to stay with the boat until the Coast Guard arrived. We knew it wasn't going to take them long to change their minds.

After about 15 minutes, with darkness approaching, they wisely decided they wanted off. Because *Profligate* has twin engines, two transom stairways, and an easily launchable dinghy, we, having also dropped the main, took over the rescue operation while *Malolo* stood by. It was easy. Our crew dumped the dinghy into the water, and we simply dragged it behind the cat with a long line until it blew down against *Existential Blowout*. Macris and Lindemann scrambled into it on the first pass, and Maloney on the second. All were helped up *Profligate's* transom steps by the cat's crew. To make sure Macris didn't suffer from hypothermia while in the cockpit, six of the *Profligate* gals became a giant hugging machine to share their body



**The Ventura Fire Department jet-ski rescue team — and they're good! — was a little late to the party, but they were still welcome.**

heat. Lindemann, the most shook up of the three, later needed a little of the same treatment.

Once the three were safe aboard *Profligate*, things got kind of funny, as every public service agency in Southern California seemed to want to get in on the action. Parked on the side of the two-mile-distant Pacific Coast Highway were about 20 impotent fire trucks, ambulances, and what have you, all with their red lights flashing. What the heck were they going to do? Then there was a fire department chopper that did a fly-over, and would return a half hour later to do it again. Best of all, however, was a two-man fire department team from Ventura on a jet-ski pulling a sled. The two guys were decked out in full gear, including wetsuits, booties, helmets, and waterproof radios. Without asking any questions — such as did anybody need any help — a buff young man who came to be known as 'Scuba Steve' dove in the water, swam over to *Profligate's* transom steps, and scrambled up and into the cockpit. The seven women in the crew wouldn't have swooned more if it had been the 'Hoff' himself, although Lindemann says he'd been hoping for a Pam Anderson type.

Since there was really nothing for Scuba Steve to do, and with his boss having charged over to the tri to have a look, the *Profligate* gals started fraternizing with him. But when the boss man returned on the jet-ski and saw him posing for photos, Scuba Steve was told in no uncertain terms to quit socializing and get his ass back on the jet-ski. Just to make sure the rescue was overkilled enough, two more public safety guys, on another jet-ski with a sled, showed up after dark. Call us cynical, but we think



# THE KING HARBOR RACE

all the agencies were padding their rescue statistics in order to get more funding in the future. On the other hand, it's nice to know they were so responsive and competent. The bottom line is that the three guys from the tri could/would have been saved by any number of people had we not been there.

After arrangements had been made to salvage the tri, we set a chute and resumed racing — until the wind died completely inside Santa Monica Bay about 40 minutes later. As it turned out, a salvage boat couldn't find the tri that night despite being given an exact GPS position. A Coast Guard helicopter spotted her seven miles offshore — having drifted five miles during the night — the next day. Some things had been broken, but *Existential Blowout* will



*The 'starters' on the 'Profligate' anti-hypothermia team, from the left: Doña de Mallorca, who has many thousands of ocean miles; Heather Cosaro, who is about to start her second cruise to, and in Mexico; Mary Forest, who followed up a Ha-Ha by crewing to Panama; Cherie Sogsti, who has done multiple Ha-Ha's and cruised to Florida; and Rachel Edwards, who cruised the Pacific for five years and is now attending University in China. All knew the importance of using blankets and body heat to keep Dr. Demetri — center, in black watch cap — from losing core body temperature.*

surely sail again.

All's well that ends well, of course,

and no sailors' getting injured or killed was indeed a good ending. The lessons to take from the trimaran incident are the classics: reduce sail in a timely manner, have the best drivers on the helm when it gets dicey, always be ready on the main-sheet, and always have a sharp knife ready.

As for us on *Profligate*, it was about the eighth time we've done the King Harbor Race, and despite the traditional light air frustrations at the beginning, and somehow never managing to find more than 17 knots of wind for ourselves, we had a great time and love the course.

We'll be back next year — and we bet that everyone on *Existential Blowout* and *Rattle & Hum* will, too.

— **latitude/rs**



## Tradewinds Sailing School and Club

1230 Brickyard Cove Rd #100, Point Richmond, CA 94801

Phone: (510) 232 - 7999

Email: [staff@tradewindsailing.com](mailto:staff@tradewindsailing.com)

**“Try it, You’ll like it!”**

American Sailing Association School

**Basic Keelboat (101) - \$575**

Sept 6,7,13,14

Sept 8,9,10

Sept 13,14,20,21

Sept 20,21,27,28

Sept 22,23,24

Sept 27,28 & Oct 4,5

**Basic Coastal Cruising (103) - \$725**

Sept 6,7,13,14

Sept 17,18,19

Sept 20,21,27,28

Oct 4,5,11,12

Oct 8,9,10

Oct 18,19,25,26

**Bareboat Chartering (104) - \$945**

Sept 17,18,19

Sept 20,27,28

Sept 22,23,24

Don't take our word for it,  
see what our students and members have to say!  
Review schools at [SailingSchoolReviewer.com](http://SailingSchoolReviewer.com)

**Our club members enjoy unlimited sailing for  
one monthly rate!**

**Fall Special!**  
**Save \$150 on any of  
the above courses!**

**[www.TradewindsSailing.com](http://www.TradewindsSailing.com)**

\*Expires 9/30/08



**ELLIOTT / PATTISON SAILMAKERS**

# Ragtime

## wins Tahiti Race

Congratulations to Chris Welsh and the crew of Ragtime. 1st Overall and one of three yachts to break the 14 year old elapsed time record.



**For information:**  
**949 645-6697**

LA Harbor Area:  
Steve Dair 310 619-7245

Marina Del Rey:  
Doug Johnstone  
310 528-2146

Oceanside: Lee Pryor  
760 529-0062



**We have a passion for building sails. Call us about your next set.**

**870 Production Place**  
(949) 645-6697  
**Newport Beach, CA 92663**

## Headed to the Ha-Ha?

2008 Baja Ha-Ha  
San Diego - Cabo  
October 27, 2008

Safe Voyages  
Begin with Landfall

The **Landfall Premium Personal Safety Kit** features the **Mustang Deluxe Hydrostatic Vest with Harness** and the **Wichard Double ISAF Tether**. The full kit is only **\$399.95** - \$539.89 if purchased separately (use item SPSKOP when ordering).\*

Landfall has been providing safety and navigation gear and expert advice for over 25 years. Call us at **800-941-2219** for a free catalog or expert advice. Shop online anytime at [www.landfallnav.com](http://www.landfallnav.com).

 **Landfall**  
WHERE SAFE VOYAGES BEGIN

**SAFETY | NAVIGATION | REFERENCE | WEAR**

\*Because they contain CO<sub>2</sub> cartridges, all inflatable lifejackets incur special shipping charges for 1-, 2-, or 3-day air delivery. ©2008 Landfall Navigation. All rights reserved.

# BLUE WATER YACHT INSURANCE

Blue Water Yacht Insurance covers more active cruising boats than any other marine insurance agency in the Western Hemisphere, and is the leading innovator of insurance products for the offshore sailor.

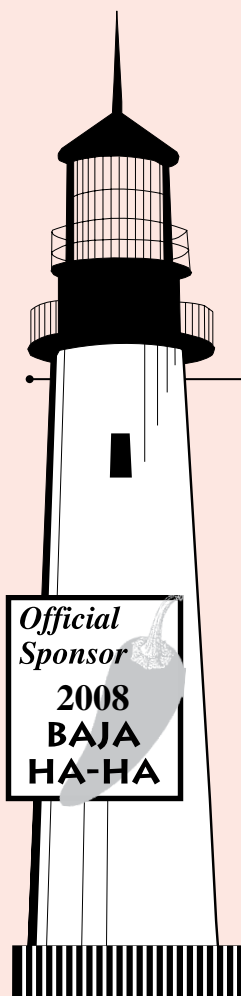

## Our Insurance Programs Provide:

- Crew of two anywhere
- Worldwide Navigation
- Hawaii
- Caribbean
- South Pacific
- Charter Boats
- Multihulls
- Liveaboards
- Racing Boats

## Quality Rated Insurance Companies

Boats aged 1 to 40 years • "Agreed Value" "All Risks" • "New for Old" replacement partial losses  
Hulls valued \$50,000 to \$2,500,000

## Worldwide Health Insurance

International and USA health insurance plans at affordable prices.

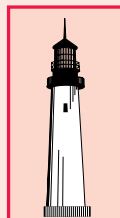

**BLUE WATER INSURANCE**  
JUPITER, FLORIDA • USA

Call Toll Free  
**(866) 463-0167**  
Fax: (866) 795-3707  
[sales@bluewaterinsurance.com](mailto:sales@bluewaterinsurance.com)

Quote requests  
Visit our website  
[www.bluewaterinsurance.com](http://www.bluewaterinsurance.com)

---

2008 SINGLEHANDED TRANSPAC





## — EASY RIDERS

**T**reachery was nowhere in evidence during the 2008 Singlehanded TransPac. But the battle for first overall did come down to youthful exuberance vs. . . . well, let's call it maturity and experience. The latter won out in the ageless Skip Allan, who at 63 still scrambles around his custom Wylie 27 *Wildflower* just like he did when he sailed her to Hanalei Bay, Kauai, in the very first Singlehanded TransPac back in 1978. He was in his mid-30s then, just a few years younger than Eric Thomas, who at 37 was the 'youthful exuberance' part of this year's equation. Thomas



sailed the bottom paint off his Duluth, Minnesota-based Olson 30 *Polar Bear*, earning his biggest fan in the only guy who beat him.

"That guy is hardcore!" laughed Skip soon after arriving in Kauai on July 28. "He knew what he needed, he made that boat strong and he hand-steered all day with the spinnaker up! He definitely had my full atten-

tion."

And everyone else's, too. When the numbers were crunched, Eric had beaten the next fastest boat by almost 24 hours on corrected time. But talk about getting

**Spread, Eric Thomas hangs five off Hanalei Bay. Above, overall winner Skip Allan.**





# 2008 SINGLEHANDED TRANSPAC

your attention: Skip's little *Wildflower* trounced the *'Bear* by the same amount again. Even for a sailor of Skip's caliber, it was a stunning performance.

More on that later.

**T**wenty-two men and one woman started the 30th Biennial Singlehanded TransPac off Corinthian YC on July 12. That was later in the year than this race had ever started before. With the last three or four races suffering from either too much wind or a painful lack of it in the early going, the sponsoring Singlehanded Sailing Society decided to try starting it two weeks later. The hope was that it would not only afford participants more steady breeze early on, but better tradewind sailing from a well-established Pacific High in the latter stages.

Great idea, but it didn't pan out. The culprit this time was a cut-off low that crept over the coast and effectively shut

*Below, Ken 'The General' Roper sailed half the race with this unintentional 'chicken chute' after a massive wrap took away the rest. It turned out to be the right sail combination to earn him a second in division. Right, Ken gets welcomed to 'Bali Hai' by daughter Leigh.*



at all. In the first 24 hours, some boats reported 'day's runs' of only 30, 40 or 50 miles. A few had single-digit distances. And everyone got a good long look at the plethora of wildlife around the Farallones.

It finally started to turn around on Wednesday, by which time the solo boats were getting passed by some Pacific Cup boats that had started the following week. When the wind finally did fill in on Wednesday and Thursday — which was also the first time most of the fleet saw the sun — it found many singlehanders well north or south of rhumbline, where they'd gone searching for breeze. Most would end up wishing they hadn't strayed so far off the beaten path.

But there was always the great reaching in the middle part of the race. There are three distinct parts to a normal Hawaii race: beating off the coast, a couple of days of splendid reaching in the middle, and then the warm downwind last part. 2006 defending champion Mark

*Serious stuff — Skip Allan, wearing his race face, was riding the rail of 'Wildflower' before the boat even passed under the Golden Gate.*

Deppe was hoping to cash in most of his chips during the reaching section, where his J/120 *Alchera* can really make some miles on the competition with her big asymmetrical kite.

To his surprise, the wind veered almost immediately from a beat to dead downwind.

"It was almost as though we lost the middle part of the race," says Deppe, a five-time Solo TranPac veteran.

And the Trades themselves seemed more 'pacific' than usual. Deppe never saw more than 20 knots, which is a bit *"This is how I looked for most of the race!" joked Bob Johnston, who went through three autopilots before re-installing the original using this jury rig.*



off the westerly for several days. During this time, conditions ranged from capricious zephyrs on all points of the compass, to an hour or two of almost steady breeze — to numerous hours of no wind







ALL PHOTOS LATITUDE/LADONNA EXCEPT AS NOTED

when approaching racers can't hear the race committee. Plus he's just a good guy. As always, upon return to Seattle, he'll haul and 'mothball' the boat on the hard until next time.

Deppe corrected out to win the division, a testament to his sailing skills considering he didn't really get any conditions he considers ideal for the boat. As mentioned earlier, even the Trades left a few knots of breeze to be desired.

"With the main and twins up, in 25 knots I can do 15s and 16s. You can put a lot of miles on your competitors that way," says Mark. "But not this time."

Second place in Division F went to Jim Fair. Like Skip Allan, Jim was also sailing in his second solo TransPac after a long hiatus. The last time he went was 1986 on his Merit 25 *Chesapeake*. This time he was sailing a newer, decidedly

more cushy *Chesapeake*, an Outbound 46. Recently retired from a career in the semiconductor industry, Jim's 'come-back tour' in the race was as much a function of shaking down the boat for a

less than optimal for his twin-headsail downwind arrangement. In his section of the ocean, he said even the squalls lacked their usual punch.

It was just that kind of a year.

Here's a look at how it went in each of the five divisions.

#### Division F (Big Boats)

The 'big boat' division consisted of five boats from 40 to 60 feet long, including Deppe's 40-ft *Alchera* and the race's biggest entry, the Open 60 *Dogbark*, owned and sailed by Seattle's Al Hughes. The latter was the first boat to finish for the third time in a row, crossing the finish line on July 24 after 11 days, 20 hours. It was the big *Dog's* quickest time so far, and landed Al a third in division on corrected time. Unfortunately, it once again fell short of his ultimate goal to set a new monohull elapsed time record. That mark of 10 days, 22 hours, still belongs to fellow Seattleite Ray Thayer, who set it on his Open 60 *Wild Thing* in the '96 race.

Al's missed record could be construed as good news by the rest of the fleet, as it's likely this popular sailor will return in 2010 for another go. Al does lots of extracurricular work — talking fellow participants through troubleshooting electrical glitches via SSB during the race, for example; and after the race using his tall rig to punch out a VHF signal



**In five Solo TransPacs — and five return trips — Mark Deppe (left) had never found a glass float. So fellow racer Jim Kellam presented this one to him at the awards ceremony. Of course, at last word Deppe had found three more before he was halfway home.**

long cruise starting this fall as it was for competition. Nevertheless, this accomplished sailor — instantly recognizable in his trademark engineer's hat — showed that the Carl Schumacher-designed hull was no slug, arriving exactly 24 hours after *Alchera* and correcting out to second.

And you've got to love this: When the



LATITUDE/UR

**Ice cream man — Jim Fair did his second solo TransPac in 22 years in a lot more comfort than his first. The race was part of a shakedown for his new 'Chesapeake', aboard which he and partner Linda will start cruising this fall.**

race committee climbed aboard to check and remove the seal on his prop shaft, Jim scored a few brownie points by offering them ice cream! As you can imagine, the usual offerings on most boats consisted of warm water, warm Pepsi or warm beer. Uh, thanks anyway.

The only two boats to return to the Bay after the start were both entered in this division. A week and about 500 miles into the race, Wen Lin on the Swan 47 *Wentimir* turned for home after feeling physically unable to go on. When stiff breeze shredded his headsails, the 70-year-old sailor set off his EPIRB and was towed in the last few miles. He and the boat survived to sail another day.

The other returning boat was two-time Solo TransPac veteran Dwight Odom on the Saga 43 *Na Na*. Electrical gremlins were playing havoc with his power and Dwight didn't want to run 'stealth' the whole way to Hawaii. After a quick fix, he took off a second time, only to have everything go dead again a day or so out. So he came back again, got fixed again and took off again. This time the boat made it 900 miles out before the prince of darkness started playing tricks. Dwight finally found a simple loose connection that brightened his boat and his day, and had no further problems. Odom is a fine offshore sailor and actually lapped several of the race's smaller entries on the way over.

As Skip Allan pointed out, "He also had the unique experience of passing the Farallones five times in one race!"

Dwight's large welcoming committee

# 2008 SINGLEHANDED TRANSPAC

of family and friends greeted him wearing identical "Third Time's a Charm" T-shirts.

## Division G (Sportboats)

With all due respect to Skip Allan — let's face it, the big surprise would have been if he *didn't* win — the biggest surprise of the 2008 Singlehanded TransPac was the amazing performance of first-timer Eric Thomas on the Olson 30 *Polar Bear*. Eric grew up around boats, supervises a marina on Lake Superior, and is a regular competitor in the Great Lakes circuit. But who would have thought that experience would translate so well to the ocean? This was the first long distance race the boat had ever done in saltwater!

But right from the start this was a guy who did his due diligence. In researching the race, for example, he found out that Olson 30s have traditionally done very well — but that half of the ones that had entered over the years broke booms. So his boom got sleeved. And he brought a spare. And the lower part of his mast got sleeved, too.

As far as the actual sailing went, Eric observed that sailing the Solo TransPac reminded him a lot of the Great Lakes — "Lots of light air, lots of heavy air, and no medium air. Just like home," he said. While several boats left light-air sails at home, Eric's big genoas helped him



Eric harkened back to the iron men days of yore by hand steering much of the day. That extra bit of attention earned him the race's top speed — a tad under 18 knots on a good surf in a squall.

And speaking of squalls, Eric's unique brand of singlehanded madness dictated that the kite stay up until the first squall of the night. Sometimes that was 9 p.m. Sometimes it was 2 a.m. When the 30 knots of rain and darkness hit, he'd ride it out till it passed, then sock the spinnies, pole out the twin 130 jibs — and start in with a series of 30-minute catnaps for the remainder of the night.

And what did this Lakes sailor think of those big, scary Pacific squalls? "Back home we get 50 knots and lightning," he said. "Now *that's* a squall."

Finishing second in the sportboat division was Bob Johnston on the Benicia-based J/92 *Ragtime!*. Bob's a returning veteran of the 2006 race in which he also placed second in division. But he was a

**Ya-hey! Vancouver's Jim Kellam sails his well-traveled 'Haulback' into Hanalei on his third solo TransPac. After the '04 race, he sailed all the way around the world, arriving back in Hanalei in time to greet the arriving '06 fleet.**

newbie then, and was happy just to get to Hawaii in one piece. This time, he was hoping to do better, and he did manage to shave more than two days off his '06 time. But glitchy autopilots and the decision to leave light-air sails at home hamstrung the effort. Not to mention the fact that it became evident early on that *Polar Bear* was on a mission, and since he was *Ragtime!*'s main competition (*Polar Bear* rates 99 to *Rag's* 105), about all Bob could do was sit back and admire Eric's performance.

Third in Division G was newcomer Don Gray on the slippery Jutson 30 *Warrior's Wish*. Don, who came out from North Carolina to do the race, admits to having a Type A personality when it comes to competition. Having raced the boat to a second (both ways) in last year's Bermuda 1-2, he was hot to prove his mettle on the left coast. And 'hot' is what he proved to be, although not in the sense he'd hoped.

About halfway through the race, Don's big aso spinnaker did a death spiral around the headstay. And none of the 'traditional' ways of untangling it



**The longest yard — for 'Ankle Biter's Allan Hebert, the 2008 race really started way back in 2004.**

work through the first few days. When the Trades filled in, the spinnaker went up and stayed up most of the time.

Although modern autopilots can steer squirrely ultralights these days (Eric had high praise for his Raymarine 4000),





*Some got there quicker, some were more comfortable — but no one was happier to complete the 2,120-mile course than Ruben Gabriel on the jury-rigged 'Sparky', especially when he saw that his family had flown in to surprise him.*

worked. He wasn't the only one to suffer this problem in this or any other Solo TransPac. But he's the first one we know of who came up with the idea of burning it down.

After first donning full 'battle gear' — long sleeves, a hat and gloves — to protect him from fallout, Don attached a length of wire leader from his anchor rode to the jib halyard — which was inside the wrap — taped a flare to the end of it, lit the flare and hauled the roman candle up inside the mass of nylon.

"You could see the glow of the flare in there, and I waited until it set the sail on fire," says Don, a former marine who was probably calmer than most of us would be in a similar situation. "Once it got going, I pulled the flare out and let it burn for a while." But not too long, as he was afraid it might melt the jib halyard or catch the main on fire.

"Then I'd grab as high as I could reach and snap real hard," he said. He got a few chunks at a time that way. It took four flares over a period of several days to finally clear it all, and that was the end of that spinnaker. Weirdly, the sock survived with a few minor burns.

In fact, that was it for spinnakers on the 'Wish, period. He'd brought two, and the day before the big wrap, he'd man-



LATITUDE/JR

*In his right hand, Don 'Burning Man' Gray holds the last mortal remains of his cremated spinnaker. In his left, the sock, which was in serious condition but expected to survive. "It's pretty funny now," he joked. "It wasn't then."*

aged to run over his first one and get it caught around the rudder. The only way to get it off was to stop the boat, dive in and cut it free in mid-Pacific.

Although the competitor in him was understandably frustrated — he sailed the rest of the way into Hawaii under main alone, once hitting 14 knots — he eventually got into the laid-back rhythm of the event and was as thrilled as anyone else who's dropped anchor in beautiful Hanalei Bay for the first time.



Alan Hebert rounded out the Sportboat fleet, sailing his SC 27 *Ankle Biter* across the finish line after 17 days. The feeling of personal accomplishment that sailors feel upon completing this race is one of the main reasons they do it. But for Alan it had special significance.

He had started the 2004 race on another boat but had to turn back when heavy weather started breaking bulkheads loose. It gave him such a sense of unfinished business that, for him, the 2008 race really started four years ago. And he admits that early on, this one loomed more like the a nautical sword of Damocles than a fun adventure. What if something else broke? What if he had





# 2008 SINGLEHANDED TRANSPAC

to turn back again? Fortunately, one by one, Alan kicked the demons overboard and he started to enjoy himself. Still, it would be hard to find a finish line that meant more to any sailor than Hebert.

"The goal is achieved, the passage done, the crossing crossed," he wrote later in his online log. "The beauty remains, but the drive, and the ache that goes with it, is gone."

The entry ended with, "Never, ever let go of your dreams. You never know when you might be able to make them come true."

## Division E (Mid-Size Monohulls)

In the mid-size monohull division, Vancouver's Jim Kellam once again held forth aboard his Spencer 35 *Haulback* to win his division. In 2002, he won division and overall honors, and in '04, he got second in division. The funny thing is, his elapsed time of 16 days and change was almost identical in all three races.

After the '04 race, Jim sailed the boat all the way around the world and was back in Hanalei in time to greet the '06 fleet. His baby blue *Haulback* was a welcome sight for those sets of tired eyes.

Kellam's secret weapon, if you can call it that, seemed to be his quirky sense of humor. As ever, he and Ken Roper on *Harrier* co-hosted the daily *Harrier and Haulback Show* on single sideband, covering just about every subject imaginable, from those related to sailing, to the best way to behead a chicken. (Most of the fleet chose to turn down the volume and catch up on their reading during that discussion.) Of course, the whole time he talked, *Haulback* was charging along like a seagoing locomotive.

But stuff happens even to the best sailors and best prepared boats. Jim



And you know, I would soap up with saltwater and rinse with fresh. So there I was, just beginning my fresh water rinse, all lathered up and *wham!* — down we went. I looked and the spinnaker pole was in the water and the boat's not coming up. And I said, 'gosh darn' — twice."

"By the time I got it all sorted out I'd spilled all my fresh water and had to start all over again."

Roper's *Harrier* finished second in division, and therein lies another tale. Ken Roper, aka 'The General', turned 78 this year and this is his 10th Singlehanded TransPac on the same boat — his Finn Flyer 31. In all that time, he has had four podium finishes — a first in 2000, and three seconds, including this latest one. What made this one different was that he sailed the last week of the race with a spinnaker wrapped even worse than *Warrior's Wish*. This one made a cat's

**Pictures from the '08 yearbook (clockwise from above) — Barbara Euser sails 'Islander' into Hanalei Bay; 'Bear' hugs — Eric and Sarah Thomas; big Al Hughes sails the race's big boat, 'Dogbark', out the Bay; John Hayward points to the scene of the crime; Dwight Odom (in glasses) surrounded by his 'Third Time's a Charm' welcoming committee.**

cradle of the headstay, spreaders and top of the mast. But amazingly, about 60% of the bottom of the kite stayed full. Unable to get the mess unwound, and still having some control via the sheets, Roper just rolled with his (beheaded?) 'chicken chute', carrying it up to and across the finish line.

John Hayward on the Valiant 40 *Dream Chaser*, finished third in Division E. About mid-race, he suffered his own mishap, but there was nothing funny about this one. While he was on the foredeck, the jam cleat holding the whisker pole topping lift chose that moment to come loose. The pole slid down its track and walloped Hayward on the head. It



**One hand (and mouth) for the boat, one hand for more important things. Chris Humann demonstrates his finely-honed solo sailing skills.**

recounts one incident that happened the day before he finished . . .

"I was in the middle of a shower, eh?"





welcomed by the race committee and fellow racers as if she'd won the whole thing.

### Division D (Small Monohulls)

"I didn't do anything special," said Skip Allan. "I knew several days before the race that we were going to have light air. A number of boats went north or south, but I just tried to sail the shortest course because it looked like the whole way the High would stay pretty far north. So I just tried to keep the boat pointed at Hawaii."

Of course, anyone who knows Allan is accustomed to the modesty that belies his status as the West Coast's most accomplished — and least recognized for it — sailor. Talk to Skip one on one and he's just another nice guy. Do a bit of web surfing or asking around and you will realize that in the '60s, '70s and '80s, this guy was one of the greatest racing helmsmen in the world. A short glimpse at a long resume reveals 27 Hawaii races, an

Wylie building boats — he has racked up 90,000 miles of sailing most of the Pacific Rim, including a win of the Doublehanded Division of the 2002 Pacific Cup.

So when Skip says it was 'nothing special', you can rest assured he's the only one who thinks that.

Even guys like Allan are not immune to the caprices of mother nature, though. His autopilots were unable to hold the boat on course with the spinnaker up, so it only saw duty for about 12 hours the whole way. The twin poled-out jibs were better, until the day he was below getting a short nap and the wind started really hooting. The windvane rounded the boat up and the windward twin went aback, wrapping its spinnaker pole around the shrouds as neatly as bending a coat hangar over your knee.

"By the time I popped my head out of the hatch, we were over on our ear," he said. Fortunately, the pole was the only casualty. Skip rigged one of several spares and kept on truckin'.

When we asked him to compare this race to his first one in '78, he said "no"

## RESULTS

Boat	Type	Skipper	Homeport	Elapsed (d/h/m)	Corrected
<b>MULTIHULL DIVISION</b>					
1. <b>Hecla</b>	Hammerhead 54 tri	Jeff Lebesch	Fort Collins, CO	12:12:48	13:06:28
<b>DIVISION F (big boats)</b>					
1. <b>Alchera</b>	J/120	Mark Deppe	San Francisco	13:19:06	12:03:03
2. <b>Chesapeake</b>	Outbound 46	Jim Fair	Berkeley	14:19:43	12:12:57
3. <b>Dogbark</b>	Open 60	Al Hughes	Seattle	11:20:59	13:07:08
4. <b>Na Na</b>	Saga 43	Dwight Odom	Sausalito	17:11:56	15:08:42
<b>Wenlemir</b>	Swan 47	Wen Lin	Tiburon	DNF	
<b>DIVISION G (sport boats)</b>					
1. <b>Polar Bear</b>	Olson 30	Eric Thomas	Duluth, MN	14:01:53	11:15:35
2. <b>Ragtime!</b>	J/92	Bob Johnston	Benicia	15:00:34	12:01:19
3. <b>Warrior's Wish</b>	Jutson 39	Don Gray	Oriental, NC	16:02:35	14:04:39
4. <b>Ankle Biter</b>	SC 27	Alan Hebert	Alameda	17:20:48	14:05:39
<b>DIVISION E (mid-size monohulls)</b>					
1. <b>Haulback</b>	Spencer 35	Jim Kellam	Vancouver, BC	16:23:44	12:05:30
2. <b>Harrier</b>	Finn Flyer 31	Ken Roper	Myrtle Beach, SC	17:06:51	12:18:29
3. <b>Dream Chaser</b>	Valiant 40	John Hayward	San Francisco	17:01:45	13:19:25
4. <b>Sunquest</b>	Westsail 32	Joshua Siegel	Brisbane, CA	19:06:46	14:09:35
5. <b>Feolena</b>	Valiant 32	Rob Tryon	San Francisco	19:06:38	14:19:27
<b>Islander</b>	Bristol 34	Barbara Euser	Norfolk, VA	21:03:33	FAD**
<b>DIVISION D (small monohulls)</b>					
1. <b>Wildflower</b>	Custom Wylie 27	Skip Allan	Capitola	16:00:06	10:21:37*
2. <b>Black Feathers</b>	Cal 20	Robert Crawford	San Francisco	19:21:49	13:03:17
3. <b>Carroll E</b>	Dana 24	Christian Humann	Berkeley	19:05:17	13:07:22
4. <b>Feral</b>	Intl. Folkboat (26')	Tom Kirschbaum	Alameda	19:16:44	13:15:52
5. <b>Kali O Kalani</b>	Hawkfarm 28	Nicholas Ratto	Alameda	19:11:55	14:19:15
<b>Sparky</b>	Pearson Electra	Ruben Gabriel	Benicia	25:21:22	FAD**

\*Overall winner

\*\* Finished After Deadline

didn't knock him out, or even down, but he says it pretty much put him out of commission for several days. "It took almost a week before I started feeling normal," he said. Even after arrival, his neck still made cracking sounds when he turned his head a certain way.

Rounding out the race's largest division, in order of finish, were Joshua Siegel's Westsail 32 *Sunquest*, Rob Tryon's Valiant 32 *Feolena* and Barbara Euser's Bristol 34 *Islander*.

*Feolena* beat *Sunquest* on the clock, with the former finishing only 12 minutes in front of the latter — although the higher-rated Westsail corrected out ahead. Many thought it was the closest finish in Solo TransPac history.

Barbara Euser was this year's only woman participant. She ran out of power early on so ran silent for the entire race until she was in VHF range. Unfortunately, after all that, she finished about an hour after the noon Saturday deadline. As is customary, she was nevertheless

Admiral's Cup win on the breakthrough Holland 40 *Imp* and participation in the infamous 1979 Fastnet Race.

On *Wildflower* alone — which he modified from a production half-tonner back in 1975 when he worked for Tom

— several times.

"I had no SSB, no GPS, no liferaft and no engine. There was no finish line and not even a race committee. You had to find your way to Hawaii by celestial navigation.

# 2008 SINGLEHANDED TRANSPAC

"There was a Club Med in Hanalei back then, and somebody had arranged for them to host the race. But when we walked up to announce we'd arrived, they said 'Who are you?' Seems the management had changed at some point and nobody told the new people. So they basically told us to get lost and from then on we took our own times."

For the record, the 'new' Singlehanded TransPac requires daily check-ins, everyone navigates by GPS, liferafts are required, and autopilots do most of the steering. Oh, and each competitor is greeted by a very attentive race committee who helps them anchor and delivers the 'beverage of choice'. This varies from ginger beer or shakes to Mai Tais or other rum drinks, with the common denominator being that it must be ice cold. Race Chair Synthia Petroka sweetened the greeting ceremony this year with the addition of a cool, scented washcloth so each arrival could wash the salt off with a taste and smell of the islands.

**S**econd in the small-boat division was the race's smallest boat, Bob Craw-

ford's Cal 20 *Black Feathers*. (It was also the oldest, having been built in 1961.) As he predicted, Bob was the last official finisher, but when his 267 rating was fed into the number cruncher, he ended up second in division and ninth overall.

Sliding into third place was Chris Humann on the Dana 24 *Carroll E*. Those who follow this race may recall that Chris' participation in the 2006 race was cut short when another boat got into trouble and Chris went to that skipper's aid. Although the crippled boat made it under his own power, Humann took down most of his sails and escorted the wounded boat the whole way, finishing well beyond the deadline (which that year had even been extended a week).

This year, Chris enjoyed the entire performance.

Rounding out the division were Tom Kirschbaum sailing the International Folkboat *Feral* and Nick Ratto sailing the Hawkfarm *Kali O Kalani*.

## Multihull Division

There was only one multi in this year's race, Jeff Lebesch's Hammerhead 54

*Hecla*. A newcomer to racing — in fact, a relative newcomer to sailing, having completed courses at OCSC in 2000 — Jeff sailed the boat well, if conservatively, finishing second boat-for-boat 16 hours behind *Dogbark*. Jeff, who lives in Fort Collins, Colorado, used his experience as a triathlete to judge whether he was pushing too hard or not hard enough. If he was feeling really exhausted, that was the signal to back off a bit. Feeling good? Crank it up a notch.

One big 'notch', and perhaps Jeff's biggest thrill of the race, was setting his big new spinnaker for the first time. Until then, he had less than an hour of spinnaker experience — with *any* spinnaker, not just this one. He reviewed the procedure several times, checked and double checked all lines and unfurled the beast. It opened with a boom and the boat took off. "It was a real kick in the butt," he said.

Not too many hallucinations reported among the fleet this year, but Jeff managed to give himself a good start when he came from below to find a guy standing there in the cockpit. Turned out to be



## OWL HARBOR MARINA

### THE FRIENDLY MARINA

**HOME OF  
ANDREAS COVE YACHT CLUB  
Limited Time Only  
\$100 Memberships  
Call for details**

- 30'-50' deep draft berths @\$5.50 per foot
- Dry and open storage
- Extra wide berths for multihulls
- Home of Club Rio Sailing School



**'CANVAS BY THE LOOP'**  
On-site canvas & repair shop

- SAIL - Alterations & Repair
- CANVAS - New & Repairs
- SAILBOAT RIGGING
- HARDWARE INSTALLATIONS
- 12-VOLT REPAIR & INSTALLATION
- FAST TURNAROUND ON REPAIRS

LOCATED ON SEVEN MILE SLOUGH  
OFF THE SAN JOAQUIN RIVER  
HARBORMASTER: SHAWN PASSERI  
**(916) 777-6055**  
email: [shawn@owlharbor.com](mailto:shawn@owlharbor.com)  
[www.owlharbormarina.com](http://www.owlharbormarina.com)  
1550 W. TWITCHELL ISLAND RD.  
ISLETON, CA 95641



his foulie pants drying in the wind.

**B**ut of all the skippers on all the boats in this race, perhaps the most elated to finally cross that finish line — more than a week after the deadline — was Ruben Gabriel on the Pearson 23 Electra *Sparky*.

Two thirds of the way into the race, and roughly 700 miles from the finish line, *Sparky* dismasted. The conditions were windy and bumpy and Ruben was as exhausted as any other singlehander trying to function on sporadic 20-minute naps. In Satphone conversations to home and the race committee, he reported that he had saved the mast and gotten it secured on deck. He then explored his options, suggesting perhaps that Honolulu might be the best detour because it was closer and had better repair facilities. The race committee said they'd go along with any decision Ruben made, but as far as they were concerned, he was still in the race. Perhaps if he got a bit of rest and reconsidered . . . ?

Sure enough, by the next day, Gabriel



**Rob Tryon enjoys his first post-race meal ashore. "Wow, this food is actually cooked!"**

was under jury rig and underway — for Hanalei. The day after that, he reported he had put up an even taller jury rig using much of the mast, and was making 3.5-4 knots!

In another hallmark of the Singlehanded TransPac, the boats that could wait for their last compadre — did wait. And finally, on August 8, 27 days after he started, here came *Sparky* chugging over the horizon. Ruben's smile was as wide and as white as the surf dashing against Kilauea point. Although the race

committee had departed by then, two boats and a proper welcoming committee motored out to greet the last man home. But perhaps Ruben's biggest reward came when he stepped ashore to find not only his girlfriend, Robbie, but his whole family, who had flown over to surprise and congratulate him. Ruben and Robbie later got engaged on a visit to the Kilauea Lighthouse.

**S**kip Allan's final log entry for the 2008 Singlehanded TransPac captured the spirit of this race in particular, and in a larger sense all those that have gone before:

"Sometimes in life we are fortunate to be part of magic happening. The 2008 Singlehanded TransPac has been an incredible coming together of energy, creativity, friendship, and just plain hard work. Every competitor has faced and overcome challenges to arrive here. It is in overcoming these challenges, often with help from others in the fleet, that we have forged friendships that will last a lifetime."

— **latitude** /jr

*in Southern California...*



*A First Class Full Service Facility Serving the Entire Pacific Coast  
150 Ton & 30 Ton Travelifts*

## VENTURA HARBOR BOATYARD

Open 6 Days a Week!

Competitive Rates ~ Professional Staff

*For quality and attention to detail you can count  
on our commitment to your satisfaction.*

**(805) 654-1433**

1415 Spinnaker Drive, Ventura, CA 93001  
[www.vhby.com](http://www.vhby.com)

## Self-Steering and Emergency Rudders

Don't leave port  
without'm!



### MONITOR WINDVANE™

Servo Pendulum with  
optional emergency rudder

**BEST FOR MOST BOATS**

See us at the  
**ANNAPOLIS  
BOAT SHOW**  
October 9-13  
Tent C • #29

### auto-helm windvane

Auxiliary Rudder/Trimtab

**NO LINES –  
EMERGENCY RUDDER  
PERFECT FOR DAVITS**

### Saye's Rig

**FOR HYDRAULIC STEERING/HIGH FREEBOARD**

Pendulum trimtab on  
main rudder

### SOS Emergency Rudder

**BREAKS DOWN AND  
STOWS UNDER DECK**

**VISIT OUR UPDATED WEBSITE**

3,000 BOATS AND MORE THAN 5,000 PHOTOS (added daily)

**[www.selfsteer.com](http://www.selfsteer.com)**

FACTORY DIRECT

**SCANMAR**  
INTERNATIONAL

432 South 1st St. • Pt. Richmond, CA 94804

Tel: 510 215-2010 • Fax: 510 215-5005

Toll Free: 888-WINDVANE (946-3826)

email: [scanmar@selfsteer.com](mailto:scanmar@selfsteer.com)

# IDIOT'S GUIDE

Despite several advances in offshore voice communications such as satphones, marine single sideband (SSB) isn't going away anytime soon. That's because SSB radio, unlike satphones, allows an unlimited number of people to listen to a transmission at the same time.

As such, SSB radio is the only way to go for the various regional cruising

*Radio signals within the SSB shortwave spectrum refract off the ionosphere and come back to earth hundreds to thousands of miles away without the need for communication satellites and/or ground stations.*

nets, such as the Baja, Sonrisa, Chubasco and Southbound nets. It means, for example, that when Don Anderson of *Summer Passage* transmits his latest weather forecast, an unlimited number of people can listen in at once. And when someone has a question about the forecast, everyone can hear the question and Don's response.

Marine SSB is also perfect for cruising events such as the Baja Ha-Ha, the Caribbean 1500 and the Atlantic Rally for Cruisers. "While the Ha-Ha doesn't require SSB radio," advises the Grand Poobah of that event, "most boats do have them. They are good for safety — but fun, too. The folks with SSB radios are able to actively participate in all the roll calls, weather and fishing reports, and other fleet news. Over a period of nearly two weeks, personalities develop over the radio, and an even greater sense of community is established."

In racing events such as the Pacific Cup, the TransPac and this year's revived Tahiti Race — where SSB is required of all entries — it offers more than just straight communication. "Thanks to marine SSB, our 1700 hour reports and discussions maintain the racing camaraderie and fun," comments Jack McGuire, KG6CJN, communications chairman of the just-completed '08 Pacific Cup race from San Francisco to Hawaii.

Although not the subject of this article, the other significant benefit of SSB radios is that they, when used with a Pactor modem and SailMail, allow for the transmission and reception of short emails while offshore.

## Licensing

You don't need to pass a Ham radio operator's test to operate marine SSB. All that's required is a valid Ship Station license and a lifetime Restricted Radiotelephone Operator's permit. No testing required! The Ship Station license is good for 10 years and is non-transferable. If

you're good at dealing with government online forms, you can apply for a license yourself at <http://wireless.fcc.gov/>. If you're not so good at it, or don't want to take the time, my lovely wife Suzie will be happy to help for a fee: (714) 549-5000.

How is Ham (amateur radio) different from SSB radio? If you're new to long distance marine radio, I suggest not even worrying about it. Although I run the Radio School and some of the income comes from teaching students how to use Ham radio and pass the test, I generally discourage new SSB operators from taking that step right away. Get the no-test

might consider eventually moving up to Ham status. But generally speaking, it's really only for serious radio buffs.

By the way, there is nothing to prevent folks with SSB radios from listening on Ham frequencies, and indeed, there are some helpful weather broadcasts on Ham-only frequencies. If you're new to SSB radio and worried that you might accidentally stumble onto a Ham-only frequency, start transmitting, and really piss off the 'radio police', fear not. SSB radios that are capable of working Ham frequencies come 'locked' from the factory. Some can only be unlocked using software, while others can be unlocked by just pressing three keys at the same time. In cases of genuine emergencies, Ham frequencies can be used even by people who don't have a license.

## How Far On What Bands?

A marine SSB system operates on a marine radio spectrum called 'shortwave', medium frequency and high frequency — 2 MHz-26 MHz. This radio spectrum is shared with hundreds of other radio users such as shortwave broadcasts, Ham radio, FEMA, the American Red Cross and long-range aircraft.

Radio signals within the SSB shortwave spectrum refract off the ionosphere and come back to earth hundreds to thousands of miles away without the



***In the realm of cruising, an SSB radio is a lifeline, an email gateway and a hub of friendly conversation, like an old-fashioned party line.***

license for SSB radio, become familiar with the procedures and protocols, and use it for a few months. If you find that you're one of the very few cruisers who talks on the radio so much that SSB frequencies aren't adequate, then look into Ham radio. Or, if you're going to the South Pacific, where there is lots more traffic on ship-to-ship channels, you

need for communication satellites and/or ground stations. Each marine SSB radio frequency band has a very predictable skywave bounce 'bulls-eye'. If you choose a band that's too high, your signal will skip over the other station. If you choose a frequency that's too low, your signal won't go far enough to reach the other station.

The following is a good guide for



choosing the band of frequencies that will target your first skywave bounce:

2 MHz	.....200-400 miles
4 MHz	.....400-600 miles
6 MHz	.....600-1,200 miles
8 MHz	.....800-1,600 miles
12 MHz	.....1,200-2,400 miles
16 MHz	.....1,600-3,200 miles
22 MHz	.....2,200-4,000 miles plus
26 MHz	.....unpredictable during our solar cycle minimum

**Pop Quiz #1:** You are in San Francisco and you want to talk with your buddy who is on his boat 1,200 miles away in Cabo San Lucas. Which band on marine SSB might you choose?

**Answer:** Because 4, 6, and 8 MHz would likely fall short on the first radio signal bounce, 12 MHz and 16 MHz would likely be your best choices.

The thing that usually drives new SSB operators nuts — and I know that it still irritates the Grand Poobah of the Ha-Ha — is that SSB radio frequency/channels are so different from VHF, FM, television and almost every other kind of channel. On VHF, for example, channel 72 is channel 72. On television, channel 7 is channel 7. What could be more simple?

Certainly not SSB radio. Get this: while 4146 is always 4146 on SSB, it's also known as 4A, and sometimes the designator 4-1. In addition, depending on the individual radio, it's often channel 35 or channel 77, but could also be some other channel. That's right, depending on what radio you bought and when, and who might have customized the user channels, channel 35 and channel 77 may or may not be 4146 and vice versa. And, of course, it might also be channel 63 or 147 — or a bunch of other channels.

The most sure way to get to 4146 is to just tune to 4146. The problem is that you may have to do a lot of knob turning, which gets to be annoying. In order to eliminate unnecessary wrist injuries from knob turning, some manufacturers 'channelized' the more popular frequencies. That is, they assigned specific channels to specific frequencies. For example, the Icom SSB radios of several years ago assigned channel 35 to frequency 4146 (aka 4A and 4-1). That was all well and good. Unfortunately, in later radios they

decided to assign channel 77 to 4146 (aka 4A and 4-1). In addition, some retailers created custom 'user channel' packages, which gave yet another channel designation to 4146.

How did it all come to this? SSB operators used to have to spin the frequency knob like crazy to find anyone because there are more than 1,000 SSB frequencies — only a very few of which will ultimately be of interest to you. (More on that later.) As a result, most modern marine SSB transceivers — a fancy name for a combined transmitter and receiver in one black box — have nearly 700 pre-stored duplex channels — a channel simply being a specific frequency designated as a channel for easier access. After all, what's easier, dialing through 1,000+ frequencies or 700 channels?

Nonetheless, you could spin your SSB channel dial all day long and you'd probably still hear nothing — except for WLO, the excellent radiotelephone station located in Mobile, Alabama. If you want to pick up something, look for on-the-hour weather and traffic reports on the following International Telecommunications

Union (ITU) three- and four-digit designators: 405, 417, 805, 824, 830, 1209, 1212, 1226, 1607, 1624, 1641, 1807, 2237 and 2503. If you punch in 1607 on the hour, you'll get traffic lists and weather broadcasts from powerful WLO. The U.S. Coast Guard also broadcasts voice weather reports on ITU channels 424, 601, 816, 1205, and 1625.

Because SSB radios are more complicated than VHF radios, you initially might have a little trouble punching in all the three- and four-digit ITU channels and/or the actual frequencies. Maybe I can help.

ICOM America, Furuno, and SEA are the last remaining SSB manufacturers, and of the three, ICOM is the undisputed leader when it comes to equipping recreational vessels with marine SSB gear. To assist North American sailors in more easily calling up relevant ship-to-ship, Coast Guard, weather facsimile, Ham and marine telephone stations, they have pre-programmed 160 "favorite channels" — channels 1 through 160 — into a memory circuit titled 'User Channels'. These channels begin with the informal

## Latitude 38's Easy Guide to Mexico Nets Baja California & Mainland Mexico

### Daylight Savings Time Schedule (Summer Time)

Time				Latest ICOM Channel	Freq kHz Pri / Sec	Upper/Lower Sideband	Net Name
UTC (GMT)	PDT W. Coast	MDT Cabo, LAP	CDT PVR, ACA				
*** Marine SSB Nets ***							
0:30	17:30	18:30	19:30	92	6224	USB	Southbound Net
14:00	7:00	8:00	9:00	105	8122/8116	USB	Amigo Net
N/A	N/A	N/A	N/A	95	6516	USB	Bluewater Net
*** Listen-Only Ham Nets ***							
14:30	7:30	8:30	9:30	149	7294	LSB	Chubasco Net*
15:00	8:00	9:00	10:00	141	7238	LSB	Baja Net
19:00	12:00	13:00	14:00	156	14340	USB	Manana Net*
19:00	12:00	13:00	14:00	151	14300	USB	Pacific Seafarer Net

\* NOTE: Net warm-up and coordination sessions frequently begin prior to the published net opening time.

### Standard Time Schedule (Winter Time)

Time				Latest ICOM Channel	Freq kHz Pri / Sec	Upper/Lower Sideband	Net Name
UTC (GMT)	PDT W. Coast	MDT Cabo, LAP	CDT PVR, ACA				
*** Marine SSB Nets ***							
0:30	16:30	17:30	18:30	92	6224	USB	Southbound Net
14:00	6:00	7:00	8:00	105	8122/8116	USB	Amigo Net
N/A	N/A	N/A	N/A	95	6516	USB	Bluewater Net
*** Listen-Only Ham Nets ***							
15:30	7:30	8:30	9:30	149	7294	LSB	Chubasco Net*
16:00	8:00	9:00	10:00	141	7238	LSB	Baja Net
19:00	11:00	12:00	13:00	156	14340	USB	Manana Net*
19:00	11:00	12:00	13:00	151	14300	USB	Pacific Seafarer Net

\* NOTE: Net warm-up and coordination sessions frequently begin prior to the published net opening time.

Time adapted from Docksideradio: [www.docksideradio.com](http://www.docksideradio.com)

# IDIOT'S GUIDE

designator #1, and end with #100 — unless, of course, you have the new ICOM 802, which has user channels #1 to #160.

For example, if you have an Icom 802 and tune to Channel 77, you'll find that you'll be on frequency 4146 (aka 4A). And if you tune to Channel 118 on an 802, you'll find yourself on frequency 3968, which is home to the Sonrisa Net at 7:30 a.m. Pacific Time in the winter. It will even show 'Sonrisa Net' on your screen, even though the Sonrisa Net only uses that frequency a few hours each day.

Your radio will no doubt also have a toggle for 'channel/frequency'. As you toggle it, the display will switch back and forth from, say frequency 4146 to Channel 77 — assuming, of course, that 77 has been assigned to 4146 on your particular radio.

Take this opportunity to run all the user channels on your radio, and make a list of what frequencies/stations they

refer to. As mentioned, if you have a newer Icom 802, it's very likely, but not certain, that you have the same channel/frequency combinations as owners of other new Icom 802s. But if you have an older Icom model, or perhaps had a custom user channel package put into your 802, I'd recommend you have an authorized Icom dealer come down and give you the most recent user channel package. All he does is plug his computer

Latitude 38's favorite SSB channels that I've compiled to help you better understand that each channel has a specific purpose. You'll notice there aren't 700 of them. That's because you can only use 33 primary channels. And for cruisers in California and Mexico, you'll almost exclusively use just five of them: 4A, 4B, 4C, 8A and 8B. That's not many, but you'll rarely have trouble finding an open channel. (There are an additional 49 secondary channel/frequencies on the 4 MHz and 8 MHz bands that you can use if they aren't being used at the time, but if you're just starting out, you don't need that additional confusion.)

The main thing to do is play with your user channel/frequency combinations so you become familiar with them. It won't take long. If you find that your channels are out of sync with most other folks' SSB radios, you might want to change yours to match theirs. Depending on how technical you are,

*For cruisers in California and Mexico, you'll almost exclusively use just five of them: 4A, 4B, 4C, 8A and 8B.*

into the front of your radio and download the new stuff. It shouldn't take more than 15 minutes, and will synch you with the majority of other SSB radios.

If you look at the sidebar, you'll see



## More Fun in the Great Outdoors!



**Wheel-a-Weigh® Dollies**  
Get your small boat or kayak to the water quickly & conveniently!



**NEW**  
**Inflatable Key Buoy™**  
Never lose keys in the water again! When Key Buoy falls in the water, an air tube automatically inflates, carrying your keys to the surface.



**Air-Dryer™**  
An inexpensive and effective way to fight mold, mildew, moisture, and corrosion. Silent, low-cost operation.



**NEW**  
**Knot-a-Bag® Plastic Bag Dispenser**  
The most convenient plastic bag—anywhere! Unique dispenser lets you make bags of any length.



**NEW**  
**Quick Fist® Rubber Clamps**  
Heavy-duty one piece rubber clamps keep tools and equipment firmly in place.



**Windex™ 15 Wind Indicator**  
The standard on mastheads around the world.  
Sapphire suspension system ensures high sensitivity. Seeks direction in winds as little as 2/10 knot. Wind tunnel tested to 80 knots. Spike above vane discourages birds from landing.



**Vantage Pro2® Wireless Weather Station**  
Breakthrough technology transmits weather data wirelessly 1000 feet! Large LCD display; sensor suite measures rain, temperature, humidity and wind.

**Davis Instruments**  
3465 Diablo Ave., Hayward, CA 94545 U.S.A.  
800-678-3669 • sales@davisnet.com  
www.davisnet.com



you may or may not need assistance.

### Calling For Help Over The SSB

In addition, there are six Coast Guard Global Maritime Distress and Safety System (GMDSS) channel/frequencies: 2182, the distress channel; 4125 (4S); 6215 (6S); 8291 (8S), 12,290 (12S); 16,420 (16S). The Coast Guard or other international rescue agencies monitor them 24 hours a day. U.S. Coast Guard monitors out of Hawaii, Guam, Alaska, San Francisco, New Orleans, Miami and Norfolk.

Warning! Remember, different bands have different ranges. If you make an emergency call on 2182 when you're half-way between Mexico and the Marquesas, it's very unlikely anybody is going to hear you. If you check the earlier chart, you'll see that you'd actually want to transmit on 12,290 (12S) where the range would be 1,200 to 2,400 miles.

### Checking Your SSB Reception And Transmission

OK, you're getting some meaning-

### Latitude 38's Favorite SSB Channels

When cruising Mexico, these are the only channels you'll really need for calling ship-to-ship or ship-to-California.

Channel Designator	Latest ICOM Downloadable Channel	Frequency kHz
4A .....	77 .....	4146 kHz USB
4B .....	78 .....	4149 kHz USB
8A .....	97 .....	8294 kHz USB
8B .....	98 .....	8297 kHz USB

ful reception as you dial around the channels, but you'll probably still be wondering if your SSB is working as it should. One way to begin to find out is by trying to pick up the time signals at 10 and 15 MHz and WWV, which provide a continuous signal for a ready reference. If you're still at the dock and plugged in, you may find that turning off the shorepower battery charger will make a huge difference in your reception. Ditto for the refrigeration and any fluorescent lights or inverters that might be turned on.

If you're unsure whether or not you're transmitting, you can tell a lot by looking

at the LCD display on the face of your radio. First, push the 'TUNE' button, at which point the radio should briefly transmit a low power signal to tune the automatic antenna coupler. Do this on any 6 MHz channel as long as there is no traffic on it. The word 'TUNE' should flash a couple of times on the LCD screen, and then stay up on the screen when the radio cycles back to receive. Still see the word 'TUNE'? This is good. However, if the word 'THRU' comes up, or 'HI SWR', you've got problems. At that point it's probably time to bring in a NMEA-qualified marine SSB specialist to see what's wrong between your radio and your tuner.

Assuming you do get 'TUNE', it's time to pick up the mic and try a short transmission. After doublechecking that the frequency is clear, key the mic, and speak directly into it saying "FOOO-OUUUUR." The mic should be touching your lips when you do this. If the following things happen, it suggests that your transmission is good and powerful:

- 1) The LCD bar graph goes full scale.

## We Still Offer More!



**Making boating easier – and more fun! – is what a marina should be all about.** That's why Oyster Cove Marina rates number one with many Bay Area boaters. It's an exclusive yet reasonable facility of 219 berths, accommodating pleasurecraft in slips up to 60-ft long. **Oyster Cove is the private Peninsula marina closest to bluewater boating.** Want to cruise to Sausalito, lunch at Tiburon, or sail to Angel Island? How about a day's fishing outside the Gate, or a weekend at the Delta? No other private Peninsula marina is better situated or offers nicer, fresher surroundings.

## OYSTER COVE MARINA

385 OYSTER POINT BOULEVARD #8A,  
SOUTH SAN FRANCISCO

**(650) 952-5540**

- Berths 30 feet to 60 feet
- Double Finger Concrete Slips
- Telephone Available
- Five Minutes from SFO
- Heated Dressing Rooms & Showers
- Laundry Room
- Nightly Security Patrol
- Complimentary Ice
- Cable TV/High Speed Internet
- Recently Dredged
- End Ties Available at \$5.75/Ft!

# IDIOT'S GUIDE

- 2) Your cabin lights dim slightly.
  - 3) The instrument indicator lamps glow.
  - 4) The bilge alarm squeaks.
  - 5) The house battery drops about a half volt.
- It is perfectly normal for instrument panel lights to glow and bilge alarms to squeak when a powerful 100 watts are

coming out of your marine SSB. But most important, doublecheck that the LCD transmit indicator shoots across the screen when you say a very loud "FFOOUUUUR".

A potentially more dangerous way to test the transmit power output is with a small fluorescent tube at night. Ask your first mate to hold the glass tube against the insulated backstay antenna or the big white whip. *Caution! Be sure they don't touch the backstay with their fingers or other parts of their body, as this could result in a nasty burn or worse.* Say the magic word, "FFOOUUUUR" once again, and the tube should instantly light up. The glass must actually be touching the radiating antenna or antenna lead-in single wire for this to happen.

If, when you say the magic word "FFOOUUUUR," the cabin lights dim, the bow head flushes, numerous bilge alarms go off, and the fluorescent tube lights up, chances are excellent that you're putting out 100 watts. But are they clear watts? Only a radio test with another SSB user can determine that, so ask someone else in the marina to dial in

## Using an SSB in an Emergency

Marine SSB has been allocated hundreds of international channels, some of which are closely guarded by the U.S. Coast Guard and worldwide rescue agencies. They are prepared to act immediately on any received Mayday or call for medical assistance. The Coast Guard maintains 24/7 distress radio guards on the following frequency bands:

2.182 MHz	.....	good for only close-in distress calls
4.125 MHz	.....	400-800 miles
6.215 MHz	.....	600-1200 miles
8.291 MHz	.....	800-1600 miles
12.290 MHz	.....	1200-2400 miles
16.420 MHz	.....	1600-3200 miles

Emergency example: You're sailing from Zihuatanejo to the Marquesas, a crossing of roughly 2,800 miles. About halfway across a thruhull pops off with water gushing in fast. Could you raise the Coast Guard on 2182 kHz? Nope. Too low a frequency. Your best bet would be to switch to 12 Safety, 12,290 kHz, and call for any Coast Guard station. It's likely that Hawaii and Point Reyes would respond, maybe even Guam, to help note your position and situation. If you needed to bail out, they could get on their GMDSS Inmarsat system and hail the closest ship in your area to talk you out of stepping off a perfectly good sailboat, and instead just plug the damn leak! In any case, it's nice to have someone know where you are when emergencies arise.

Introducing...

**NORTH SALES**  
**direct**



...a new experience in sail buying for racing and cruising sailors!



Visit our new website today to learn how you can save on new North cruising or racing sails\* ...or call toll free at 888-424-7328.

**northsailsdirect.net**

\*boat size restrictions apply

formerly Cruising Direct

Launching in June 2009

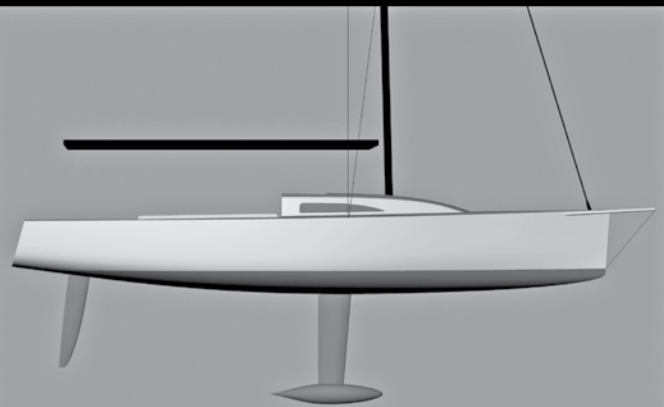

LS-30

LOA 27 ft 10 in	Draft 6 ft	Displacement 4,073 lbs	Rigging Carbon	Hull Cold-molded	Power Inboard diesel
--------------------	---------------	---------------------------	-------------------	---------------------	-------------------------



The Landing School

www.landing-school.edu



# TO MARINE SSB

a common ship-to-ship channel, such as 6224, and run your radio check. This will be a good test for a nice, clean signal.

If your test partner reports that your sound was garbled and you've just added a new email modem to your rig, temporarily disconnect the wire going from the back of your marine SSB to the computer. If your voice now sounds clear, these additional wires are the problem. Snap-on filter chokes are available from your local marine electronics specialist which may resolve the garbled voice problem.

A good test for the range of your radio is with me! I'm happy to offer *Latitude* readers free, on-the-air radio checks on an appropriate SSB frequency that will agree with the approximate range between your station and mine, here in the Newport Beach area. If your boat is in the Bay Area, we will likely use 8 MHz. If you are local, we'll go with 4 MHz, and if you're down at Cabo, we'll probably choose 12 MHz. Call me on the phone at (714) 549-5000 weekdays and we'll find a nice quiet channel for our radio check.

Another great way to test your marine

SSB transmit-and-receive capability is with weather guru Don Anderson on his marine SSB Amigo Net. He begins at daybreak, at 1415 hours Zulu (UTC) on 8.122.0 MHz, upper sideband. If you have the latest frequency load from Icom America, it's already stored in memory as channel 105. If you don't find it in memory, you will need to break out the instruction book and learn how to program a new frequency to be stored in your user programmable frequency 'bin'. It's not hard, but if you've never done frequency programming before, it can be a mystery. You might want to call in a marine electronics tech familiar with marine SSB equipment. Try Don Melcher of HF Radio On Board (Alameda) at (510) 814-8888; Shea Weston of Offshore Outfitters (San Diego) at (619) 225-5690; Steve Helms of Marine Radio Consultants (San Diego) at (619) 276-5530; Ron Romaine of KKMI (Richmond) at [ron@kkmi.com](mailto:ron@kkmi.com). Or me. I'll try to talk you through the process.

I've got two final tips.

First, if you sent your Icom 802 to the factory to get the 'clipping' problem fixed, you'll note that there are two places to plug in the antenna. One is for the DSC antenna, the other for your SSB antenna. Unfortunately, they are not clearly labeled. A number of people have gotten their radios back and plugged their SSB antenna into the wrong port. As a result, transmit and receive range are minimal. You would see an antenna tuner error if plugged into the wrong jack. Set it up temporarily and test it with time signals.

Second, Icom is very conservative in an attempt to make sure none of their radios violate FCC rules on output power and how wide the signals are. I think they are too conservative. If you get that voice compression software unlocked, your radio transmissions will boom out with a commanding signal like Voice of America. The software upload is only available from authorized Icom dealers. They can come aboard and plug it into your radio, as well as the most recent 'user channel' update. It usually takes just 15 minutes.

— *gordon west*



**Blue Sky**  
ENERGY

## Increase Your Solar Output With Solar Boost™ MPPT Solar Charge Regulators

Get All The Power You Need To Weather Any Storm

The Solar Boost™ 3024i & 2000E are two of the most reliable Solar Charge Controllers on the market & our patented technology extracts all the power your solar panels can deliver, up to 30% more!

Blue Sky Energy Inc. gets rave reviews in *Practical Sailor*. Read the article at [www.blueskyenergyinc.com](http://www.blueskyenergyinc.com)

800-493-7877 or 760-597-1642  
2598 Fortune Way, Suite K, Vista, CA 92081 USA  
E-mail: [sales@blueskyenergyinc.com](mailto:sales@blueskyenergyinc.com)  
Web: [blueskyenergyinc.com](http://blueskyenergyinc.com)

QUALITY....RELIABILITY....BLUE SKY ENERGY, CHANGING THE WAY SOLAR IS USED EVERYDAY

# BAJA HA-HA PROFILES, PT I

As the end of summer draws near, we'll soon be able to look up in the sky and see great flocks of birds migrating south for the winter. Likewise, out on the ocean, West Coast sailors from as far north as Alaska will soon be gathering in San Diego to take part in the annual southbound migration called the Baja Ha-Ha.

With the promise of sunnier skies and a substantially slower pace of living south of the border, this year's fleet will depart San Diego October 27, bound for Cabo San Lucas, with the customary stops along the way at Turtle Bay and Bahia Santa Maria.

Whether motivated by some primal instinct — as are our feathered friends — or simply a yearning to escape the rat race, it's a safe bet that, as you read this, every participating crew is getting seriously psyched up about this grand adventure. For many of them, in fact, despite having decades of sailing experience, this 750-mile run to the Cape will be their first significant offshore trip.

Judging by the roster of entries (at [www.baja-haha.com](http://www.baja-haha.com)), this year's fleet is stacking up to be fairly typical of years past: a wide range of boat types, whose owners come from a wide range of backgrounds — from surgeons to school teachers.

One thing that caught our attention, though, is the preponderance of unusual — if not downright wacky — boat names this year. There is both a *Don Quixote* and a *Rocinante* (his horse). There's both a *Trumpeter* and a *Bugler*. There are two *LunaSeas* as well as a *Bonkers*. And in addition to *Flibbertigibbet* — which is sure to be a challenge for the Rally Committee during daily roll calls — there's a *Wandering Puffin*, a *Flying Penguin* and (our current favorite) *Mystical Crumpet*.

Regardless of the boat name, though, or the amount of money spent to prepare for the voyage, they'll all arrive at Cabo's spectacular anchorage within hours of each other, wearing similarly broad smiles of accomplishment. Here, then, is the Baja Ha-Ha 'class of '09', listed in the order in which they signed up. (Two additional installments will appear in *October and November*.)

## **Miela — Moody 44**

### **Bill & Karen Vaccaro, Chico**

*Occupations:* Bill, seed production agronomist; Karen, finance director of a Boys & Girls Club

*Add'l Crew:* Robbie Murphree, Ruben Gabriel, Craig & Lamia Alger

*Quote:* "After completing the '04 Ha-Ha, we've kept *Miela* in Mexico, and she

likes it hot!"

*Cruise Plans:* South for the winter, then to the Sea of Cortez for the spring.

*Noteworthy:* Bill and Karen's sailing career began when they learned to windsurf 15 years ago.



*'Miela' already knows the way to the Cape. She'll now take Bill and Karen on 'round two'.*

## **Eager Dreamer — Andromeda 48**

### **John & Rosie Olson, Blaine, WA**

*Occupations:* John, V.P. of wood products co.; Rosie, loan officer, both retired

*Add'l Crew:* John's brother Richard Olson

*Quote:* "Livin' the dream!"

*Cruise Plans:* Open-ended cruising.

*Noteworthy:* No one believes this sleek Bruce Bingham design is built of ferrocement.

## **Norsk Vind — Wauquiez 43PS**

### **Jim & Phyllis Knutson, Lake Forest Park, WA**

*Occupations:* Jim, retired airline pilot; Phyllis, real estate agent

*Add'l Crew:* Sam Stitt & Ken Greff

*Quote:* "I have been planning this adventure since 1965." (The year he learned to sail.)

*Cruise Plans:* South to the Canal, into the Caribbean, across the Atlantic to Scandinavia and return.

*Noteworthy:* Between them, Jim and Phyllis have sailed to Hawaii, Alaska and the Eastern Caribbean, but neither they, nor their crew have sailed to Mexico before.

## **Samantha — Nauticat 38**

### **Scott Brear & Linda Lorenz, San Francisco**

*Occupations:* Scott, retired attorney &

financial advisor; Linda, RN

*Add'l Crew:* TBD

*Quote:* "We think of this as the ultimate vacation, and an opportunity to meet many like-minded people from diverse backgrounds."

*Cruise Plans:* Explore the Sea of Cortez, then coastal Mexico and points south for one or two years.

*Noteworthy:* Scott's previous sailing adventures include three round trips between Hong Kong and the Philippines.

## **Alegria — Hunter 460**

### **John & Anna Sabree, San Leandro**

*Occupations:* Steve, pilot; Anna, retired graphic designer

*Add'l Crew:* Jude Miller & Ron Whitfield

*Quote:* "We're stoked!"

*Cruise Plans:* To La Paz, then points south.

*Noteworthy:* Although the Sabrees are now based in the Bay Area, they, and their boat, hail from official hailing port is Pass Christian, Mississippi, outside New Orleans.



*John and Anna of 'Alegria' are transplants from the old south.*

## **Drum — Tayana 37**

### **Andrew Signal & Elizabeth McKnight, Alameda**

*Occupations:* Andy, sailing instructor & delivery skipper; Elizabeth, marketing manager

*Add'l Crew:* daughter Cleo Signal, 4, and Stephen Henderson

*Quote:* "I tried civilization, but found it disagreed with me."

*Cruise Plans:* Back north in January.

*Noteworthy:* Andy began sailing at age 9 — but his daughter Cleo's got him beat.



# — SOUTHBOUND MIGRATION



The Conger family of 'Don Quixote' are following in the wake of Grandma and Grandpa.

## **La Palapa — Catalina 440**

**Roger & Tobé Hayward, King Harbor**

*Occupations:* Roger, engineer; Tobé, aerospace engineer

*Add'l Crew:* Scott Cincotta & Micah Shelley

*Quote:* "When we first saw this boat, we laughed at it, thinking it was the ugliest boat we'd ever seen. But now we love it!"

*Cruise Plans:* Possible circumnavigation via the canals.

*Noteworthy:* This will be the Haywards' third Ha-Ha run.

## **Di's Dream — Catalina 470**

**Roger & Diana Frizzelle  
San Francisco**

*Occupations:* Roger, yacht sales

*Add'l Crew:* Jeff Chessher, Eric & Marilyn Anderson

*Quote:* "The lower the latitude, the better the attitude."

*Cruise Plans:* Bash home in February.

*Noteworthy:* Roger and Di can't seem to get the Ha-Ha out of their systems. This is their fourth.

## **Tumbleweed — Cal 39 Mk III Ted & Alicia Morgan, Seattle, WA**

*Occupations:* Both retired from the insurance biz.

*Add'l Crew:* Greg & Jan Dold

*Quote:* "We're pretty ordinary, but will try to live up to the boat's name: *Tumbleweed*." (Huh?)

*Cruise Plans:* Winter and spring cruising Mexico, summer on the hard in San Carlos, then . . . "Who knows?"

*Noteworthy:* Alicia started sailing at age 10, but Ted claims his on-the-water

*We're anxious to meet the 'Tumbleweed' crew so we can understand the name's significance.*



training began while still in his mother's womb.

## **Misjudged II — Hunter 460 Patrick Magers, Newport Beach**

*Occupation:* Superior court judge  
*Add'l Crew:* Bill Schroeder, Jon Wheeler & Paul Dickerson

*Quote:* "My crew were shocked that *Misjudged* placed first in class at the '06 Ha-Ha. They naturally attributed the win to a mistake by race officials. I'm hoping for another *mistake* this year."

*Cruise Plans:* To PV, then bash back in April.

*Noteworthy:* Although Bill and Jon were aboard on the '06 Ha-Ha, Paul opted to do the Bash home instead. He quickly realized his error in judgment, so he immediately started begging for an '08 crew spot.

## **Scrimshaw — Endeavour 37 Don & Patricia Lambdin, Vallejo**

*Occupations:* Don, engineer; Patricia, administrator

*Add'l Crew:* John Mouritsen, Keith Watson & Pat Wolf

*Quote:* "This will be a great first leg to start my third transpacific cruise"

*Cruise Plans:* "Cruising."

*Noteworthy:* Don first heard about the rally several years ago in Guam.

## **Cat's Meow — Catalina 36 Nancy DeMauro, Richmond**

*Occupations:* Sales

*Add'l Crew:* Donna & Mike DeMauro, Joann Jackson & Lorre Henderson

*Quote:* "Every time I sail out the Gate, *Cat's Meow* turns herself toward Mexico. She's ready to go."

*Cruise Plans:* Sadly, no further cruising this time. *Cat's Meow* will be trucked home or delivered by hired crew.

*Noteworthy:* Nancy learned to sail a decade ago, and bought this boat — her first — five years ago.

## **Flibbertigibbet — O'Day 34 Betty & Jim Adams Discovery Bay**

*Occupations:* Betty, sailmaker/office manager; Jim, self-employed

*Add'l Crew:* Remsen Barnard

*Quote:* "Our kids think we're crazy. They may be right."

*Cruise Plans:* Open-ended.

*Noteworthy:* Since you're probably curious, our dictionary defines flibbertigibbet as "a frivolous, flighty, or excessively talkative person." Hmm. Would that be Betty or Jim?

# BAJA HA-HA PROFILES, PT I

## Follow You Follow Me — Hunter 466 Allan & Rina Alexopulos Redwood City

*Occupations:* Allan, global account manager; Rina, retired from sales.

*Add'l Crew:* Philip & Josie Failers, Corey & Bernice Wurzner

*Quote:* "Since creating our cruising plan five years ago, learning to build each of our goals and needs into the planned journey has taught us as much about each other as we had learned in the 25 years we have been married."

*Cruise Plans:* Cruise Mexico, then the Eastern Caribbean. Later, perhaps an about-face and on to the South Pacific.

*Noteworthy:* Fond memories of a BVI bareboat charter inspired the couple to pursue the cruising lifestyle.

## Solitude — Catalina 30 Allan & Jo-Anne Collister Emeryville

*Occupations:* Self-employed

*Add'l Crew:* Their son Peter, 21

*Quote:* "We've planned to do this trip for about 25 years — and doing it with a group is a no-brainer."

*Cruise Plans:* A month or more of



*Preparing 'Follow You Follow Me' for cruising has taught Rina and Allan valuable lessons.*

cruising out of La Paz, then bash back or store her on the hard.

*Noteworthy:* Allan and Jo-Anne took sailing lessons together while they were students at Cal.

## Citla — Cal 39 Mk III Peter & Kathleen Mirrasoul San Diego

*Occupations:* Peter, microbiologist; Kathleen, human resources

*Add'l Crew:* Scott Henderson

*Quote:* "Looking forward to new learning opportunities, new friends and new adventures."

*Cruise Plans:* "Future plans will be decided by life's unfolding adventure and our own enthusiasm."

*Noteworthy:* Peter's father, a lifelong boater and amateur boatwright, gave him and Kathleen both the inspiration and the means to buy this boat and sample the cruising life.

## Third Day — Pearson 365 The Boren family, Bakersfield

*Occupations:* Richard, filmmaker; Lori, "cruiser"

*Add'l Crew:* Their son, Jason, 10, & daughter, Amy, 11

*Quote:* "The house is rented, so there's no turning back now!"

*Cruise Plans:* Cruise Mexico and Central America, then on to the Caribbean.

*Noteworthy:* They did the Ha-Ha last year — only three years after they began sailing — then bashed home, which was "a piece of cake in late February."

## DELIVERY CAPTAIN

*We'll Do The Baja Bash For You!*

**Book Now!**

MARINE SURVEYS ALSO AVAILABLE

**Cabo to San Diego or L.A....\$1800 +cost\***

**Cabo to San Francisco....\$2500 +cost\***

Price includes Captain and one crew. Call for other delivery locations.

- ◆ 30+ Years Experience
- ◆ More Than 100,000 Miles at Sea
- ◆ Power and Sail
- ◆ Serving the Entire West Coast

\* Cost is for provisions and transportation.

**BDI Marine Service**

**(707) 570-9093 • redwitchbbc@yahoo.com**



Celebrating 40 Years of Excellence

**Survive Your Dream**

**'Great Atlantic Gear Test'**

**Always rated #1 or #2!**

Courtesy Jimmy Cornell



**YACHTING**  
MONTHLY

100  
best bits of gear - ever!  
HYDROVANE included twice!

**Hydrovane is both:**

- ★ Self Steering
- ★ BEST Emergency Rudder

**SHOWERS EVERY DAY!**

**ECH<sub>2</sub>O Tec Watermakers**

**BUILT TO LAST**

www.hydrovane-watermakers.com

www.hydrovane.com

604-925-2660

info@hydrovane.com



# — SOUTHBOUND MIGRATION

**Bamboo — Passport 45**  
**Timothy & Michelle Lutman**  
**Des Moines, WA**

*Occupations:* Timothy, geologist; Michelle, Social Security rep

*Quote:* "Our last big adventure."

*Cruise Plans:* A few years in Mexico, then South Pacific

*Noteworthy:* This boat was sailed to the States from Taipei by its original owner.

**Don Quixote — Lagoon 380**

**The Conger family, Seattle, WA**

*Occupations:* Dean, ophthalmologist; Karen, "freelance humourist"

*Add'l Crew:* Daughters, Jaime, 12, Mera, 10 & Aeron, 8

*Quote:* "Sometimes you have to try even when you know you look like an idiot."

*Cruise Plans:* Mexico until summer.

*Noteworthy:* Dean's parents did the Ha-Ha in 2001.

**Endless Summer — F-41 cat**  
**Steve May, Emery Cove Marina**  
*Occupation:* Grocer



*For Jo-Anne and Allan of 'Solitude', transition to the cruising life has been a long time coming.*

*Add'l Crew:* Steve's girlfriend, Manjula Dean; his father, Bill May; and friend Kurt Frederick

*Quote:* "I can't believe that I am this lucky. I get to sail to Mexico with my amazing girlfriend, my best friend from grade school, and my dad — all people I love."

*Cruise Plans:* Cruise Mexico until May, then home.

*Noteworthy:* Although Steve just bought this boat — his first — a year

ago, his sailing career began when he was only 4 years old.

**Risk Taker — Catalina 38**  
**Duane Rawson & Christine Anderson, San Francisco**

*Occupations:* Duane, contractor; Christine, cost accounting

*Add'l Crew:* Robert Stewart

*Quote:* Duane: "Can't wait!"

Christine: "Whatever the skipper wants."

*Cruise Plans:* Cruise Mexico, then possibly to the Caribbean.

*Noteworthy:* Previous destinations the couple has sailed in include Ireland, Morocco and Croatia.

**Princess Anna — Mainship 390 trwr**  
**Michael McGuire**  
**Channel Isl. Harbor**

*Occupation:* Environmental engineer

*Add'l Crew:* Tom Yohe

*Quote:* "Repeating the Ha-Ha is a great opportunity to meet cruisers, have fun and use cruising skills." He did the 2003 event.

*Cruise Plans:* Cruising out of La Paz

*Noteworthy:* At the time of his applica-

THERE'S A NEW  
 SHERIFF IN TOWN

Rated "EXCELLENT"  
 & "BEST BUY"

Powerboat Reports®  
 2004, 2005, 2006,  
 2007, 2008



## BLUE WATER® MARINE PAINT

KKMI® is pleased to promote Blue Water™, rated "EXCELLENT" by Powerboat Reports®. Blue Water™ contains higher concentrations of premium domestic copper & active ingredients, and only use virgin rosins, colorants & solvents in all antifoulings. Blue Water™ is the only distributed marine paint that offers a 1-year written warranty against premature hard marine growth.



### COPPER PRO SCX 67 HARD™

FULL SEASON - 67% COPPER - BOOSTED MODIFIED EPOXY

Blue Water® Copper Pro Scx 67 HARD™ \$229.99

Pettit® Trinidad SR™ \$249.99

Interlux® Ultra with Biolux™ \$269.99



530 West Cutting Blvd.  
 Pt. Richmond, CA 94804

(510) 235-5564  
 KKMI.COM

# BAJA HA-HA PROFILES, PT I

tion Tim was looking for two additional crew.

## **Victory Cat — Seawind 1160 cat Tim & Ruth Henning, Seal Beach**

*Occupations:* Tim, engineering manager (retired submarine officer); Ruth, retired banking rep

*Quote:* "Looks like a fun way to start the cruising season going south."

*Cruise Plans:* Cruise Mexico until spring, then west into the South Pacific.

*Noteworthy:* Victory Cat was named in memory of a lost brother who lived to ride Victory motorcycles.

## **Wandering Puffin — Islander 41 William & Barbara Holbrook Hallowell, ME**

*Occupations:* William, attorney; Barbara, youth advocate, both retired

*Quote:* "We have friends everywhere — we just haven't met some of them yet."

*Cruise Plans:* Several months in Mexico, then "south and west."

*Noteworthy:* Todd honed his nav skills years ago as assistant navigator aboard



*Plans are open-ended for Kathryn and Jay of 'Kat Den Rie'.*

a U.S. Navy destroyer escort.

## **Kat Den Rie — Catalina 42 Mk II The Watt family, Alameda**

*Occupations:* Jay, facilities manager; Kathryn, sales and marketing

*Add'l Crew:* Daughter Kensey, 22, & Barry White (no, not that Barry White)

*Quote:* "Life is not a spectator sport. Do it now!"

*Cruise Plans:* Cruise the Gold Coast and Sea of Cortez until May, then decide.

*Noteworthy:* Jay and Barry are lifelong friends.

## **Thumbs Up — Catalina 42 Mk II Ivan & Cheryl Orgee, Alameda**

*Occupations:* Ivan, contractor; Cheryl, business manager

*Quote:* "Cruising is our new career."

*Cruise Plans:* Mexico, then on to Polynesia and New Zealand.

*Noteworthy:* Ivan's sailing career began in 1960.

## **Nirvana — Irwin 44 Bob & Sherry Davis, Shell Beach**

*Occupations:* Bob, aerospace exec/naval aviator; Sherry, retail

*Quote:* "This is the next chapter in our 37-year adventure together, half of which has been spent apart for job reasons. Now we'll see if we really like each other!"

*Cruise Plans:* "Where the winds and currents carry us."

*Noteworthy:* Three years ago they vowed to do this event after an astronaut friend said, "Without a committed departure date and tide, you're not serious

# Life Line

by

## WAGNER INSURANCE

Since 1978

*Life Insurance Rates That Will Keep You Afloat*

- Compare our rates with anyone.
- More than 50 companies to choose from.
- Many other Life and Health products.

### TERM LIFE INSURANCE RATES:

\$250,000 COVERAGE, SUPER PREFERRED NON-TOBACCO, MONTHLY PREMIUMS							
FOCUS TERM PREMIUM RATES:	ISSUE AGE	10-YEAR POLICY		20-YEAR POLICY		30-YEAR POLICY	
		MALE	FEMALE	MALE	FEMALE	MALE	FEMALE
	30	9.84	9.19	13.78	12.47	22.09	18.38
	40	11.81	10.94	18.16	15.53	33.25	25.38
	50	25.16	21.66	47.25	33.03	71.97	51.41
60	67.17	43.97	117.69	79.84	N/A	N/A	
\$500,000 COVERAGE, SUPER PREFERRED NON-TOBACCO, MONTHLY PREMIUMS							
30	15.31	14.00	23.19	20.56	39.81	32.38	
40	19.25	17.50	31.94	26.69	62.13	46.68	
50	45.94	38.94	90.13	61.69	139.56	98.44	
60	129.94	83.56	231.00	155.31	N/A	N/A	
\$1,000,000 COVERAGE, SUPER PREFERRED NON-TOBACCO, MONTHLY PREMIUMS							
30	25.38	22.75	40.25	34.13	72.63	56.00	
40	32.38	29.75	56.88	49.00	117.25	84.00	
50	86.63	70.00	175.00	115.50	266.00	186.38	
60	246.75	158.38	456.75	305.38	N/A	N/A	

Rates are monthly. 15- and 25-year policies are also available.

Lic. #0F22446

*It's Easy!*

*Protect Your Assets. Protect Your Family.*

CALL US TODAY FOR A QUOTE: **(888) 788-8855**

WEST COAST LIFE  
INSURANCE COMPANY  
Sample Ad



# — SOUTHBOUND MIGRATION

cruisers!"

## **Sea Bisquit — Slocum 43**

**Steve Sommer, San Francisco**

*Occupations:* Retired from telecommunications biz

*Add'l Crew:* Bill Gillett

*Quote:* "I have an 18-month pass (from my spouse) to go sailing."

*Cruise Plans:* Season in Mexico, then north to B.C. via Dockwise ship.

*Noteworthy:* Steve's wife was determined to persuade him to move to San Francisco — buying the boat became Steve's "bargaining chip."

## **Mystical Crumpet — Passport 40**

**Christine & Alan Jackson, Berkeley**

*Occupation:* Alan, physicist

*Add'l Crew:* TBD

*Quote:* "We're finally doing it!"

*Cruise Plans:* Open-ended cruising.

*Noteworthy:* The couple learned to sail together in '85, and still share an equal passion for it 23 years later.

## **Double Play!! — Gemini 105 cat**

**Don Parker, Alameda**

*Occupation:* Retired electrical engi-

neer

*Add'l Crew:* Girlfriend Terri Farnstrom

*Quote:* "I hope I like it."

*"All I've ever wanted to be was a vagabond."*

*Cruise Plans:* Continue south, then eventually to the Med.

*Noteworthy:* Don says he primarily entered the event in order to secure a berth in Cabo.

## **Viva — Saga 43**

**Scott Harkey & Debra Cutting  
Seattle, WA**

*Occupations:* Scott, architect; Debra, teacher

*Add'l Crew:* Myron & Marina Eisenzimmer

*Quote:* "Yahoo!"

*Cruise Plans:* Circumnavigation.

*Noteworthy:* Having done the 2000

Ha-Ha, they know this boat is "quick like a bunny."

## **Beyond — Darwin 37**

**Michael Kary, San Francisco**

*Occupations:* Retired bicycle store owner

*Add'l Crew:* Ricki McNeill and her son Roy

*Quote:* "I'm looking for some good bluegrass jams!" (Michael is a banjo picker.)

*Cruise Plans:* Central and South American coasts; possible circumnavigation.

*Noteworthy:* Michaels says, "All I've ever wanted to be was a vagabond." Now, at age 68, he's finally getting his chance.

## **Folie A Deux — Newport 40**

**Vinny Denietolis, Sausalito**

*Occupations:* Self employed

*Add'l Crew:* Mike Campbell

*Quote:* "Hopefully, this is a new chapter in my sailing adventures."

*Cruise Plans:* To P.V. for the winter.

*Noteworthy:* Vinny believes this Newport 40 'Off-Shore Eagle' is the only

**Puerto Lucia, the gate to the South Pacific**  
www.puertolucia.com.ec

2900 miles to Marquesas Island

Galapagos At only 500 miles from Puerto Lucia

2.13 S 80.55 W

North Atlantic Ocean

Panama Canal

PUERTO LUCIA YACHT CLUB  
Ecuador

**50-ton Travelift**  
Long and short term dry storage. Maintenance and provisioning.

Excellent climate year round, floating docks, fuel, laundry, Mediterranean-style moorings, Wi-Fi, Cruiser's Lounge electric and water hook-ups.

South Pacific Ocean

**Ecuador has the Best Climate in the World**  
(Source: International Living, January 2005)

For Further information: 593-4-2783190 / 593-4-2206154 or email us: marina@puertolucia.com.ec, www.puertolucia.com.ec

# BAJA HA-HA PROFILES, PT I

center cockpit Newport 40 ever built.

## **Dragon's Toy — Island Packet 37 Tom Kohrs, Freeport**

*Occupation:* High tech

*Add'l Crew:* Sue & Dan Hudson, Anne Shipley

*Quote:* "I'm heading to Mexico as a shakedown cruise before further travels into the Pacific."

*Cruise Plans:* Winter in Mexico, north to Alaska, then south again in the fall and eventually west.

*Noteworthy:* The boat was shipped to Hong Kong and sailed the South China Sea for 5 years before returning to the U.S.

## **Current Affair — CatalinaMorgan 440 Steve & Dee Gilliland, Benicia**

*Occupations:* Steve, title insurance; Dee, City of Vacaville

*Quote:* "Because we can!"

*Cruise Plans:* Unsure.

*Noteworthy:* They intended to move away from sailing and go over to the dark side when they saw their first Catalina-Morgan 440 at the Seattle Boat Show. "It was love at first sight."



*Scott and Sue of 'Suebee' have learned a lot during their short sailing career.*

## **Pacifico — Irwin 45 Mk III Dave & Jayne Almond, Alamitos Bay**

*Occupations:* Dave, high tech; Jayne, purchasing, both retired

*Quote:* "Life is too short — and all our friends are dying!"

*Cruise Plans:* Mexico and Central America

*Noteworthy:* They've owned this boat for 32 years.

## **Silent Running — Jeanneau 45.2 Bruce & Pamela Orisek San Francisco**

*Occupations:* Bruce, surgeon; Pamela, RN

*Quote:* "It doesn't matter whether you play the penny slots or the dollar slots. The object is always to stay in the game."

*Cruise Plans:* A season in the Sea of Cortez, then on to the South Pacific.

*Noteworthy:* After purchasing the boat, new, the couple toured the Eastern Caribbean islands aboard her after she was delivered there from France.

## **Eupsychia — Cal 36 David Addleman, Monterey**

*Occupation:* Engineer

*Add'l Crew:* Heather Corsaro

*Quote:* "I should have started cruising Mexico 30 years ago."

*Cruise Plans:* "We don't make plans."

*Noteworthy:* This boat has been in David's family for 40 years.

## **Baja Ha-Ha Cruiser's Special August - October 2008 - 30% Off!**

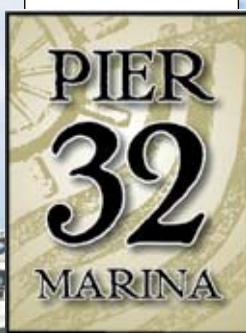

Yes, we're open! We welcome members of the 2008 Baja Ha-Ha Rally to San Diego!

Pier 32 Marina is the most beautifully developed marina in San Diego Bay with ultra modern docks and fabulous shoreside amenities including:

- 28' - 60' slips
- Deluxe shower rooms
- Spacious laundry facilities
- Exercise/workout center
- Swimming pool & Jacuzzi
- Boater's lounge
- High Speed Internet
- Free shuttle to trolley station
- Putting Green
- BBQ /Picnic Areas

*Ideal location for cruiser outfitting, provisioning and boatyard maintenance*

### **Pier 32 Marina**

3201 Marina Way  
National City CA 91950  
**Call 800-729-7547**

We are located just 6 minutes south of downtown San Diego at the mouth of the Sweetwater Channel as it enters into San Diego Bay  
office@pier32marina.com  
www.pier32marina.com



Official Sponsor  
2008  
**BAJA HA-HA**



# — SOUTHBOUND MIGRATION

**Suebee — Catalina 42 Mk II  
Scott & Sue Rader, Sausalito**

*Occupations:* Scott, real estate broker; Sue, banker, both retired  
*Add'l Crew:* Michael & Judy Stouffer  
*Quote:* "Out the Gate on '08!"  
*Cruise Plans:* Mexico, then, "Who knows?"  
*Noteworthy:* The couple started sailing only 7 years ago.

**Bonkers — J-130**

**Keith Sedwick & Arthur Cinader  
San Francisco**

*Occupations:* Keith, business owner; Arthur, online media  
*Add'l Crew:* Christian Lyndes & Kevin Bushe  
*Quote:* "Seems like a great way to kick off a season south of the border."  
*Cruise Plans:* On to P.V., then ship *Bonkers* to Canada. Later, sail back to S.F.  
*Noteworthy:* Keith circumnavigated on his previous boat, and did the Pacific Puddle Jump in '03 aboard *Bonkers*.



*John and Dianne have been 'daydreaming' for years.*

**Flyin' Penguin — Cal 2-46**

**Harold Miller, Bel Marin Keys**  
*Occupation:* Private investigator  
*Add'l Crew:* Jan Koering, Gene & Janice Abadie  
*Quote:* "My greatest adventure!"  
*Cruise Plans:* Undecided but possibly south to Costa Rica.  
*Noteworthy:* Harold has built four

boats and has wanted to do the rally since its inception.

**Daydreamer — 50' FD-12**

**John & Dianne Olson, Anchorage, AK**  
*Occupations:* John, retired engineer/manager; Dianne, retired teacher  
*Quote:* "It's been a wonderful adventure — great memories and no regrets — but where has the time gone?"  
*Cruise Plans:* Cruise Mexico in the winters and go back to the U.S. for the summers until someone else takes *Daydreamer* on her next adventure.  
*Noteworthy:* The Olsons began a 13-year cruise with the 1995 Baja Ha-Ha and they're still at it.

**Minnie Maru — Hunter 34  
William & Mary Lynn Hinkle  
Channel Islands**

*Occupation:* William, retired attorney  
*Add'l Crew:* Paul Hinkle  
*Quote:* "There's a time for almost everything in life — this is my time to go cruising."  
*Cruise Plans:* Undecided  
*Noteworthy:* The Hinkles have owned six boats, and bought *Minnie Maru* new

*Ixtapa*

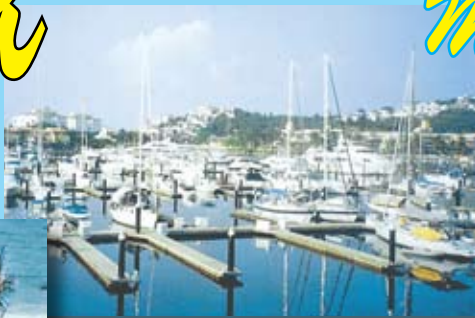

*Marina Ixtapa*

*the most spectacular  
cruise destination  
in Mexico!*



- ☀ The biggest marina in Latin America
- ☀ 621 slips from 40 to 140 feet length
- ☀ Beach club
- ☀ Ship yard with 110-ton Travel Lift

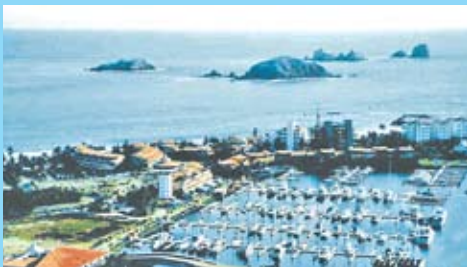

N 17°39.44 • W 101°37.12  
**Chart your course for Ixtapa – visit:**  
[www.marinaixtapa.com](http://www.marinaixtapa.com)  
 Tel: 011-52-755-55-3-21-80  
 011-52-755-55-3-02-22  
 Fax: 011-52-755-55-3-21-80  
 Email: ezuniga@marinaixtapa.com

# BAJA HA-HA PROFILES, PT I

24 years ago.

## Yancey — Gulfstar 37

### Joe & Frances Cardona, Ventura

Occupations: Joe, retired management accountant; Frances, retired underwriter

Add'l Crew: Earl Walthall

Quote: "We're excited to embark on a long-anticipated adventure that we're now able to make a reality."

Cruise Plans: Undecided

Noteworthy: The Cardonas have wanted to sail Baja since 1971, when they drove their Baja Bug down there.

## Alias — Hylas 47

### The Fluno family, Santa Rosa

Occupations: John, multidiscipline expert; LaShandra, RN.

Add'l Crew: Daughter, Keturah, 12, & son, John Jr., 11

Quote: "We can't wait to sail to Mexico — they don't have extradition, right?"

Cruise Plans: Sea of Cortez and the mainland

Noteworthy: The Flunos hope to pick up experienced crew for the trip. Did we mention they have a washer & dryer

aboard *Alias*?

## Sonrisa — Cheoy Lee 44 Fred Neilson & Cathy Mecray Lopez Island, WA

Occupations: Fred, dental lab owner; Cathy, retired

*"Let's kick the tires  
and light the fires!"*

Quote: "We're eager to get to warm water and warm winds."

Cruise Plans: Winter in Mexico then leave *Sonrisa* in San Carlos in the spring.

Noteworthy: Fred decided to enter the rally many years ago when he heard about it from a sailor he met in La Paz.

## Alegria — Northwind 43 DS Tom & Alicia Egan, Redondo Beach

Occupations: Tom, wholesale distributor; Alicia, retired teacher

Add'l Crew: Richard Egan

Quote: "This is not an adventure, but a new lifestyle."

Cruise Plans: Cruise the mainland for five or so months.

Noteworthy: This boat was custom-built in Spain.

## Deliverance — Hunter 41 Dan Swett, San Diego

Occupation: Furniture manufacturer

Add'l Crew: Tom Trebelhorn

Quote: "Our goal is to sail all the way again, and catch/release the biggest fish."

Cruise Plans: The Sea and PV.

Noteworthy: This will be the Swett's third Ha-Ha aboard *Deliverance*, which received a new mast after last year's Baja Bash.

## Jules' Jewel — Hunter 50 Rich & Julie Corbett Michigan City, IN

Occupations: Rich, electrical engineer; Julie, paralegal

Add'l Crew: Annette Corbett, Dr. Bernard Lakemaker



**INCREDIBLE SAVINGS ON FUEL AT MARINA CORAL!**  
Call for a quote ~ 866•302•0066



- The only fuel dock & best launch ramp in Ensenada
- Concrete docks from 30' to 65' with 110v/220v elect., water, cable TV, phone service and wireless internet, laundry, marine chandlery.
- Enjoy the amenities of the 147 ocean view suite resort which will make your stay the most enjoyable.

[www.hotelcoral.com](http://www.hotelcoral.com)

Reservations toll free 1-866-302-0066

E-mail: [marina@hotelcoral.com](mailto:marina@hotelcoral.com) Fax-011526461750058 VHF 71  
Carretera Tijuana-Ensenada Km. 103, No 3421 Zona Playitas, Ensenada, B.C. C.P. 22860

LET MARINA EL CID  
WELCOME YOU TO MAZATLAN!

Cruisers -  
FIRST  
NIGHT  
FREE\*



Official  
Sponsor  
2008  
BAJA  
HA-HA

A CRUISER'S PARADISE IN THE HEART OF MEXICO'S  
LUSH TROPICAL COASTLINE AND BEAUTIFUL ISLANDS

A Full Service Marina Offers...

- ★ 90 slips from 25' to 120'
- ★ Electrical and water hookups
- ★ Telephone connections
- ★ Restrooms and shower facilities
- ★ Dock Boxes
- ★ Dock Carts
- ★ 24-hour security
- ★ 24-hour laundromat
- ★ Supermarket
- ★ Dry dock
- ★ Gasoline - Diesel
- ★ Pump-out station

**NEW** Marina-Wide High Speed Wireless Internet Connections!

[www.elcid.com](http://www.elcid.com)

011-52 (669) 916-3468 • [gcevallos@elcid.com.mx](mailto:gcevallos@elcid.com.mx)

**\*Reserve for any multi-day stay and your first day is FREE!**



# — SOUTHBOUND MIGRATION

*Quote:* "Let's kick the tires and light the fires!"

*Cruise Plans:* The Sea and PV.

*Noteworthy:* Jules' Jewel was built and owned by the president of Hunter as a solo OSTAR racer.

**Rainshadow III — Liberty 55  
Brian & Dot Flanders, Sequim, WA**  
*Occupations:* Brian, "Bum."

*Quote:* "We've read about the rally for years and it sounds like fun."

*Cruise Plans:* Sea of Cortez, then on to the South Pacific.

*Noteworthy:* Like many entrants, doing the Ha-Ha is a big step for Brian and Dot, as their longest previous trip was from Brookings, OR, to Seattle, WA.

**Sea Escape — Catalina 42 Mk II  
Joe Cunningham & Ken Grady  
San Francisco**

*Occupations:* Joe, retired software company owner; Ken, retired from real estate

*Add'l Crew:* Pamela Cunningham & Willene Grady



*Dot and Brian are expanding their horizons aboard 'Rainshadow III'.*

*Quote:* "Dreams do come true."

*Cruise Plans:* Undecided.

*Noteworthy:* When we met Ken last summer in the Gulf Islands, he showed

us a *Latitude* cover of a bikini-clad sailor-girl which was taped to a bulkhead, explaining that she had given his crew inspiration as they endured a horrible bash to the Pacific Northwest.

**Alluvium — Jeanneau 47  
Sam Darbous, Seattle, WA**

*Occupation:* Retired transit operator

*Add'l Crew:* Phyllis True, Frank Richardson, Gary Parsons

*Quote:* "It's gotta be warmer than Alaska!"

*Cruise Plans:* Mexico

*Noteworthy:* Alluvium has sailed the Inside Passage to Sitka, Alaska.

**Calou — Jeanneau 47  
The Powell Family, Tiburon**

*Occupations:* Bruce, retired engineer; Pascale, full-time mom

*Add'l Crew:* Sons Francois, 14, & Antoine, 10

*Quote:* "We just want to have fun, and enjoy Mexico and its people."

*Cruise Plans:* Mexico until July, then a possible Puddle Jump.

## Peaceful Southern San Diego Bay



### HOME OF CHULA VISTA MARINA

552 slips with complete amenities from private dock boxes to pool and jacuzzi to ample free parking.

*Come feel the South Bay difference.*

Permanent or temporary berths available.



**(619) 691-1860**

*Dockmaster's office open 7 days a week*

boatslips@cvmarina.com  
www.chulavistamarina.com

## Want to fix your Atomic four?

Is the noise, mess and maintenance cost of your engine diminishing your sailing enjoyment?

- Electric repower
- Replaces up to 24hp diesel
- Powers vessels up to 13,000 lbs and 33'
- Utilizes existing controls
- Direct drop-in on current engine beds
- Extremely low maintenance
- Quiet
- Clean

the Explorer  
**\$4,995**



Where to buy:

**SVENDSEN'S  
BOAT WORKS**  
(510) 521-8454

**BASIN-MARINE**  
NEWPORT BEACH  
Since 1958  
(949) 673-3533

**SolidNav.com**  
The first alternative for everyone

www.solidnav.com  
info@solidnav.com

# BAJA HA-HA PROFILES, PT I

*Noteworthy:* This is the Powell family's second Ha-Ha, after which they cruised Mexico for eight months.

**Consigliare — Beneteau First 41s5  
Mark Sciarretta, San Diego**

*Occupation:* Retired insurance exec

*Quote:* "If anything's going to happen, it's going to happen out there!"

*Cruise Plans:* Puerto Vallarta

*Noteworthy:* This will be Mark's third Ha-Ha.

**WindSong — Catalina 42  
Edward Staples, Channel Islands**

*Occupation:* Retired engineer

*Add'l Crew:* Annette Alexander, Duane Wherland

*Quote:* "This is a trip of a lifetime."

*Cruise Plans:* Sea of Cortez, then from there, who knows?

*Noteworthy:* Staples is looking forward to meeting new people and travelling to Mexico for the first time.

**Shenanigans — C&C 35.5  
Dave Fiorito, San Francisco**

*Occupation:* Contractor



*If all goes well, the 'Calou' crew might be heading to the South Pacific next spring.*

*Add'l Crew:* Bob Edmonds, Dave & Kim Beyer

*Quote:* "I hope I make it this time!"

*Cruise Plans:* Commuter cruising out of La Paz or P.V.

*Noteworthy:* Fiorito did the first Ha-Ha and cruised Mexico for five years.

**The Rogue — Catalina 50  
Chris Nizic, Gold Beach, OR**

*Occupation:* Retired biomedical engineer

*Add'l Crew:* Earl Hill

*Quote:* "Have nothing else to do — might as well sail to Mexico."

*Cruise Plans:* "Don't like to make plans — I'm too damn old to make 'em."

*Noteworthy:* At 82, Nizic is one of the oldest entrants in the rally.

**T**hat's it for this month, but we've got a whole lot more folks to introduce you to in our October and November issues. Then, as always, we'll run a whopping recap in December.

If you're feeling sorry for yourself because all these lucky folks get to go sailing while you're stuck in the salt mine, perhaps it's time to reconsider your winter plans and join the fun. You might catch a ride via our online crew list ([www.latitude38.com](http://www.latitude38.com)) or by showing up at the the September 10 Crew List Party at the Encinal YC. See you there!

— **latitude/andy & ladonna**

## OPEQUIMAR

MARINE CENTER ~ CENTRO MARINO

**88-ton (max)  
Travelift!**  
Length to 100'  
Width to 23'

*Official Sponsor*  
**2008  
BAJA  
HA-HA**

Puerto Vallarta, Jalisco, Mexico  
Paseo de la Marina Sur #214 • Marina Vallarta, 48354  
Tel: 011 52 (322) 221 1800 Fax: 011 52 (322) 221 1978  
email: [info@opequimar.com](mailto:info@opequimar.com)

Visit Our  
Yacht Club!

Opequimar Yacht Club

First Class • Full Service

On site dining, Internet, socials

BOAT SALES  
NEW & USED BROKERAGE  
[www.opequimar.com](http://www.opequimar.com)

**West Marine**  
We make boating more fun!

**SIMRAD**  
A KONGSBERG Company

**PETTIT**  
marine paint

Come to Mexico,  
Enjoy the Mexican Riviera,  
Repair your boat at  
**OPEQUIMAR**



# BAJA HA-HA XV

## BROUGHT TO YOU BY THESE OFFICIAL SPONSORS



Turn the page for more →

134 boats have  
already registered!

## WWW.BAJA-HAHA.COM

The Rally Committee encourages you to patronize the  
advertisers who make this event possible.



Vallarta Yacht Club

Your Yacht Club South of the Border!

Where the winds are moderate, the water's warm, and the sailing's Fun!

Home of the Banderas Bay Regatta

Cruiser friendly with everything you need from a full service yacht club.

Visit us at [www.vallartayachtclub.org](http://www.vallartayachtclub.org)

Nautical Books, Software, Charts  
and more



## WAYPOINT

[www.waypoints.com](http://www.waypoints.com)

info@waypoints.com • (510) 769-1547

## WE SPEAK SSB



Radio • Email • More

[www.hfradio.com](http://www.hfradio.com)

info@hfradio.com • (510) 814-8888

## ICOM

Icom America Inc.

Award-winning Marine Communications Equipment

Handhelds • Mounted VHF • SSB • Radar

Visit one of our many West Coast dealers

[www.icomamerica.com/marine](http://www.icomamerica.com/marine)

## Head south with Scanmar, the Official Self-Steering Gear of Baja Ha-Ha XV

BUILT LOCALLY  
USED GLOBALLY  
PROVEN FOR DECADES



MONITOR  
INNOVANE

auto-helm

Saye's Rig

SOS Emergency  
Rudder

[www.selfsteer.com](http://www.selfsteer.com)

FACTORY DIRECT

## SCANMAR INTERNATIONAL

432 South 1st Street

Pt. Richmond, CA 94804

Tel: (510) 215-2010

Fax: (510) 215-5005

Toll Free: 888-WINDVANE (946-3826)

email: [scanmar@selfsteer.com](mailto:scanmar@selfsteer.com)

Summer  
is safe at  
Paradise..



Paradise Village

BEACH RESORT & SPA • MEXICO

Enjoy  
your stay  
with us!

011-52-322-22-66728 • [www.paradisevillage.com](http://www.paradisevillage.com)

marina@paradisevillagegroup.com

Making Fresh Water, Worldwide.™



Most energy efficient • Push button operation  
Quick & easy installation • Low maintenance

(415) 526-2780

[www.spectrawatermakers.com](http://www.spectrawatermakers.com)

## RIGGING ONLY

Standing and running rigging, lifelines, furlers, winches,  
headsail poles, main slider systems, windlasses,  
travelers, wire terminals, blocks and more...  
Expert advice for selection and installation.

Our 24th  
Year!

(508) 992-0434

[www.riggingonly.com](http://www.riggingonly.com)

Mexico Cruising Insurance

## Blue Water Insurance

(866) 463-0167 • (619) 226-6702

Fax: (866) 795-3707

Mexico full or part-time • Crew of two

[www.bluewaterins.com](http://www.bluewaterins.com)

# BAJA HA-HA XV

## BROUGHT TO YOU BY THESE OFFICIAL SPONSORS

### WWW.BAJA-HAHA.COM



**MARINA NUEVO VALLARTA**  
*Bahía de Banderas, Nayarit*  
**NOW UNDER CONSTRUCTION**  
230 Mooring Spaces from 22' to 130' Long  
15-year long term lease available  
Contact Dockmaster: Juan Sebastian Estrada  
Ph/Fax from US: **011 52 322 297 7000**  
juan@marinanuevovallarta.com  
[www.marinanuevovallarta.com](http://www.marinanuevovallarta.com)

Number One in Quality & Safety  
**LED NAVIGATION LIGHTS**  
by  
[WWW.SOLIDSTATEMARINE.COM](http://WWW.SOLIDSTATEMARINE.COM)  
(415) 286-4520  
Made in Marin County, California



**GERRY**  
**CORTEZ CHARTS**  
NAVIGATION CHARTS - CRUISING GUIDES  
TIDE TABLES - LIGHT LISTS  
GPS POINTS  
[www.gerrycruise.com](http://www.gerrycruise.com)



**Let Marina El Cid  
Welcome You to Mexico**  
*A Cruiser's Paradise!*  
[www.elcid.com](http://www.elcid.com)  
qcevallos@elcid.com.mx  
**011-52 (669) 916-3468**



**MARINA RIVIERA NAYARIT**  
AT LA CRUZ  
*The best marina* - 25 minutes away from Puerto Vallarta  
Tel: **322 779 91 91** or **329 29 555 26**  
info@marinarivieranayarit.com  
[www.marinarivieranayarit.com](http://www.marinarivieranayarit.com)

## ARE YOU READY TO HA-HA?

The October 27 start of Baja Ha-Ha XV is fast approaching, but there's still time to enter this life-altering event before the September 10 deadline.

As we often explain in these pages, the Ha-Ha is a 750-mile cruisers' rally from San Diego to Cabo San Lucas, with stops along the way at Turtle Bay and Bahia Santa Maria.

Prospective entrants should be clear that this offshore sailing event definitely is *not* a hand-holding service for those incapable of making this trip on their own. However, it is a fabulous opportunity to get acquainted with hundreds of like-minded cruisers as you 'cruise-in-company' along the Baja coast.

A new twist this year is that you may now sign up online at [www.baja-haha.com](http://www.baja-haha.com). As we write this, 134 boats have completed the registration process. See the website for complete event details.

Shortly after registering, entrants will receive their official event burgee by mail, along with special offers from the sponsors listed here.

## Ventura Harbor Boatyard, Inc.

*Located halfway between San Francisco & San Diego*  
Haulouts to 165 tons ~ Full line of marine services  
Dockside services ~ On-site chandlery  
1415 Spinnaker Drive, Ventura, CA  
**(805) 654-1433** • [www.vhby.com](http://www.vhby.com)



*Not just a marina - a cruiser's community*  
Your best destination across the Sea...  
[www.marina-mazatlan.com](http://www.marina-mazatlan.com)  
**011-52 (669) 916-7799**  
elizarraga@marinamazatlan.com

*'Electronic Latitude* Official Electronic Host  
*Latitude* We Go Where the Wind Blows

See *'Electronic Latitude* at  
[www.latitude38.com](http://www.latitude38.com)

## OPEQUIMAR

MARINE CENTER CENTRO MARINO  
A Full Service Boat Yard in Puerto Vallarta  
88 ton Travelift • Parts • Service • Repairs  
**011-52 (322) 221-1800** [www.opequimar.com](http://www.opequimar.com)  
info@opequimar.com

## Almar Marinas

*The West's Finest*

[www.almar.com](http://www.almar.com)





The Rally Committee encourages you to patronize the advertisers who make this event possible.

**ULTRA ANCHORS** - The quickest setting, highest holding power anchors available for you, your family and your vessel's safety.

Marine Products from the World to the USA



**QuicklineUSA**

15561 Computer Ln. #A, Huntington Beach, CA 92649  
714-843-6964 714-843-6906 fax

[www.quickline.us](http://www.quickline.us) or [info@quickline.us](mailto:info@quickline.us)

## TOTAL YACHT WORKS & C&C MARINE SERVICES

In MATZATLAN'S NEW FULL-SERVICE BOAT YARD.

We can do it all. Mechanical Repairs. Paint. Glasswork. Rigging. And more.  
[TotalYachtWorks@hotmail.com](mailto:TotalYachtWorks@hotmail.com)  
[ccmarineservices@hotmail.com](mailto:ccmarineservices@hotmail.com)



"We Fix What Won't Work."



New breakwater • New docks

Tel: 011-52 (612) 122-1646

Fax: 011-52 (612) 125-5900

email: [marinalapaz@prodigy.net.mx](mailto:marinalapaz@prodigy.net.mx)

[www.marinadelapaz.com](http://www.marinadelapaz.com)



MAKING WATER DRINKING WATER

Watermakers that improve the cruising lifestyle.

(800) 755-6701

[marine@katadyn.com](mailto:marine@katadyn.com)

0D36887

Serving Boaters Since 1959



**Cruise with Confidence**

See Our Half-Page Ad In This Issue

(800) 992-4443

[www.marinersinsurance.com](http://www.marinersinsurance.com)

Newport Beach, CA • San Diego, CA  
Burlingame, CA • Seattle, WA  
Bradenton, FL • Puerto Vallarta, MX

### IMPORTANT DATES

**Sep 10** — Final deadline for all entries.

**Sep 10** — Mexico-Only Crew List and Baja Ha-Ha Party, Encinal YC in Alameda; 6-9 pm.

**Oct 19** — Ha-Ha Welcome to San Diego Party, Downwind Marine, 12-4 pm. Ha-Ha entrants only.

**Oct 25** — Informational Meeting about the Pacific Puddle Jump, West Marine, San Diego, 5 pm.

**Oct 26, 9 am** — Final deadline for all crew and skipper waivers, West Marine, San Diego.

**Oct 26, 11 am** — Skipper's meeting, West Marine, San Diego. Skippers only please.

**Oct 26, 1 pm** — Ha-Ha Halloween Costume Party and Barbecue, West Marine, San Diego.

**Oct 27, 11 am** — Start of Leg 1

**Nov 1, 8 am** — Start of Leg 2

**Nov 5, 7 am** — Start of Leg 3

**Nov 7** — Cabo Beach Party

**Nov 10** — Awards presentations hosted by the Cabo Marina.



**THE CRUISER'S CHANDLERY**

[www.downwindmarine.com](http://www.downwindmarine.com)  
[info@downwindmarine.com](mailto:info@downwindmarine.com)

(619) 224-2733 • Fax (619) 224-7683

The southbound cruiser's source for EVERYTHING!

**Can't Wait to Outfit?**

Use our website to order early!



**The Travellers Mailbag**

SINCE 1979

Travelling anywhere? Let us forward your mail.

(415) 332-2032

[www.travellersmailbag.com](http://www.travellersmailbag.com)

3020 Bridgeway, Sausalito, CA 94965



Professional yacht brokers located in the heart of San Diego's boating community. Specialists in cruising sailboats for 26 years

[info@yachtfinders.biz](mailto:info@yachtfinders.biz) • [www.yachtfinders.biz](http://www.yachtfinders.biz)

866-341-6189 • 619-224-2349

Fax (619) 224-4692

San Diego's Newest Marina

**Pier 32 Marina**

800-729-7547

[office@pier32marina.com](mailto:office@pier32marina.com)

[www.pier32marina.com](http://www.pier32marina.com)



**West Marine**

We make boating more fun!™

Call 1•800•BOATING

(1•800•262-8464)

for a catalog or the store nearest you.

**Baja Ha-Ha Inc.**

c/o 15 Locust Ave.  
Mill Valley, CA 94941

[WWW.BAJA-HAHA.COM](http://WWW.BAJA-HAHA.COM)

There is no phone number for the Baja Ha-Ha. And please don't phone Latitude 38 with questions, as the Ha-Ha is a completely separate operation.

# MAX EBB

The yacht club employee checked his watch, waited for the signal, then unlocked the door to the courtyard and ran for his life. He knew the drill: When those doors open, a mob of sailors attacks the buffet table like a school of sharks when there's blood in the water.

We were hungry and the food was free. The sailors were back from two long Cityfront races in a good stiff summer sea breeze, and I had been helping out on one of the RC boats all day. Technically, that gave me every bit as much standing to maneuver for a good berth at the feeding trough as any of the racers, but as I was all rigged up in my club blazer and tie, I was probably not expected to dive into the fray and fight for sea room elbow-to-elbow with the foredeck hands.

Fortunately I had a collaborator who felt no such constraints.

"Yo, Max!" Lee Helm shouted from deep inside the combat zone. "There's like, a whole cold salmon in here. I'll bring you out a plate."

She emerged a minute later with two plates piled high with salmon, an assortment of raw vegetables, and dip to complement the main dish.

"How was racing on the big boat?" I asked as we found a table away from the feeding frenzy.

Lee, a grad student in naval architecture who weighs about half as much as the average foredeck crew, can almost always find a ride when weight limits are strictly enforced.

"The first race was, like, totally brutal," she said through a mouthful of fish. "Wind came up early, flood tide. Mostly upwind race, not enough live ballast. Crew limit unfair to small people."

"But this year they give boats the option of sailing with a maximum crew weight instead of a maximum number of crew," I pointed out.

"Do the math, Max. They base the weight limit on 180 pounds per crew. Yeah, right. Our certificate allows us 12 crew, that's . . . let's see . . . 2,160 pounds if we go with weight instead of number. We have to race against boats that probably average at

least 220 per person when you count the primates on the rail. So of course they kick the women off the boat and go with the crew number limit instead of the crew weight limit. They end up at 2,640. Only about 500 pounds more live ballast than we're allowed to carry. Oh no, nothing discriminatory in *that*, no way."

"At least the club puts out a good spread," I noted, hoping to cool down Lee's righteous indignation.

"If they really wanted to be fair they'd make the weight limit apply to all the boats, instead of letting the porkers have the advantage," Lee fumed.

But in racing, everything is relative. We were reminded of that by another sailor who joined us at our table. He was one of the big guys Lee was complaining about. But he was racing on an older and heavier design that had finished both races at the back of the fleet. Apparently he had sailed with Lee on other boats.

"IRC sucks," was all he said as I started to ask the usual polite question about how his racing had gone that day.

"Well, jeez," Lee reminded him. "You're on that old warhorse from the dark years of IOR. Of course you're going to get clobbered by the new boats."

"IRC is supposed to level the field," he complained, "but read the ads! Some of the new boats are designed from the keel up to be IRC racers, optimized to the rule. How they can optimize to a formula that's supposed to be secret is an inter-

esting question, don't you think? How secret is it, really? And what does IRC stand for, anyway?"

"International Rule 'Club'" Lee explained. "It's an evolution of the old CHS or Channel Handicap System used in England. Maybe the problem is that it was never intended for high-level racing. It just doesn't measure enough things — like width of the transom, for

example. That's why old IOR boats have trouble — they have all the runners and checkstays and extra spreaders

*Lean mean fightin' machines — The Holland 47 'Infinity' (foreground) and Frers 40 'Jeannette' show all the sexy curves of their IOR lineage. Today, the two local boats — both beautifully maintained by their owners — race in IRC or PHRF classes.*



and carbon foils that IRC, being a club rule, likes to penalize. But even if they've been de-IOR-ized by filling in the hollow at the after girth station, they still have the narrow stern that IRC doesn't even measure and never gives credit for. And they lose their age allowance because the hull shape has been modified."

"Right," agreed the foredeck crew as he stuffed several pastry-wrapped hot-dogs into his mouth. "IRC just doesn't do it for us."

"What's the big problem with those IOR hulls?" I asked. "Can you explain

## HOW TO FIX IRC

- End the secrecy. Open source formula, allow local administration instead of funneling through a central office at great expense and time delay.
- Only rate boats designed prior to the current rule revision. We lose a few high-end programs but support a much broader base of competitors.
- Refine the rule to include full lines measurement. Use new automated 3-D measurement devices. Most hand measurements are eliminated. The process becomes faster and cheaper.
- Allow submission of a lines file by designers, and spot check with a measuring machine.
- Use freeboard measurement, along with hull lines and water density measurement, to determine weight of larger boats. It's more practical and just as accurate as direct weighing.
- Add an inclining test to measure stability, but allow a conservative class value.





LATITUDE / JR

what it is that people are trying to fix when they modify an old race boat?"

"Just about every attempt to handicap sailboats starts with figuring out how long they are," she began. "It's the original VPP or Velocity Prediction Program: Waterline length. Hull speed. Waves in deep water move at a speed equal to the square root of gravity times length over two pi, which in knots, on Earth, works out to about 1.34 times the square root of the waterline length in feet."

"So you start with waterline length," I proposed, having extracted at least that

much out of Lee's words.

"But like, what is waterline length, really?" she asked rhetorically. "If you have a hull that tapers off to a very narrow stern — the extreme case being a rudder on a double-ender that fairs into the hull — does that count as waterline? No buoyancy from it, so the water doesn't even know it's there, at least not for hull speed purposes. The other extreme is a boat with a very wide transom that comes right down to the waterline. Lots of buoyancy all the way aft. It's the longitudinal distribution of buoyancy while sailing that controls hull speed, and using the aft end of the waterline

to determine 'length' is as arbitrary as anything else."

"You can beat a waterline rule with stern overhang" added the foredeck hand, evidently not really getting Lee's point. "Boats used to be designed to put the long stern overhang in the water when they heel."

"Actually it's not the heel that extends the waterline, it's the way the boat sinks down into the trough between so-called bow and stern waves, and the stern wave rising up around the stern overhang. Result is the same: you can get lots of buoyancy way aft from a stern overhang and make the water see a much longer



# MAX EBB

boat than the measured waterline."

"I remember the old Storm Trysail Club rule from the '50s and '60s," I said. "They just took two-thirds LWL and one-third LOA and added them up."

"And it was pretty easy to beat," said Lee. "Anyway, bow overhangs aren't much of an issue, for reasons I think you can figure out yourself. The sterns are the hard part. The rules try to assess how much useful buoyancy is going to be how far back. Obviously, if you just measure to the back of the hull, every boat would have a great big wide transom that touches the water, or a stern overhang so shallow that it all becomes useful buoyancy at any significant speed. It's not a bad way to build a boat, but like, that's not what the fleet looked like in 1970 when IOR — which stands for International Offshore Rule — was introduced."

"It was those Brits that made us put in the girth measurement," accused the foredeck hand, pointing to another very large crew who was walking by with a plate piled high with pastries.

"You got a problem with girth?" he

quipped. "Besides, I'm 'Stralian."

"Sorry," he apologized. "We were just discussing the root of all evil in measurement rules."

The large sailor turned out to be the tactician on the old IOR machine.

"Stay away from boats designed between 1970 and 1990," he advised as he joined us at our table. "Those years are the low point in yacht design history."

"With a few exceptions," Lee added, "like the Santa Cruz-style ultralights and a few other anti-IOR departures."

"But you still haven't explained what was so terrible about IOR," I said.

"The girths! Always the girths!" said the tactician. "We had to torture the water before it was allowed to flow past the stern."

"Here's how it worked," explained Lee. "First you find the maximum beam on deck. Then measure down one-sixth of maximum beam to get the spot where you measure rated beam. Then take half of that beam and cut a piece of rope

that length. Cut another piece of rope three-quarters of that measured beam. Find the spot near the bow where the half-beam rope will just reach from rail to rail under the hull. Find the place near the stern where the three-quarter beam rope will fit around the hull from rail to rail. Those are the two main forward and aft girth stations. And the distance between them — after a bunch of other corrections — is the measured length that stands in for the actual waterline length."

"Interesting way to measure waterline length," I said.

"Think what kind of shape that encourages," she said. "High freeboard, no sheer, wide beam in the middle, and pinched ends to get the girth stations as close together as possible. Designers would tuck up the bottom right at the after girth station to get it farther forward for a shorter measured length. Then there's a major flattening-out aft of the after girth station to get more of the hull back in touch with the water, and try to fool the water into thinking that the tucked-up



## wallas<sup>®</sup>

### SAFEFLAME

**85DU/270**  
**Marine Diesel**  
**Stove with Heater Lid**

2,000 to  
6,650 BTU

**UNIQUE EFFICIENT DESIGN**

- Safe no-open flame operation.
- Exhaust vented outside, helps keep cabin dry.
- Lid up: cooking. Lid down: cabin heating
- Superb marine grade construction, great looking.
- Easy to install, either flush or surface mounted.
- Super clean, variable output combustion process.

CE

---

Importer & Distributor for North America:



**ScanMarine**  
EQUIPMENT

2144 Westlake Ave N Suite D  
Seattle, WA 98109  
Ph: 206-285-3675  
Fax: 206-285-9532  
info@scanmarineusa.com  
www.scanmarineusa.com

## BOAT SHOW SPECIALS

at the  
**No. California**  
**Fall Boat Show**  
**September 6-14**



**Cadet**  
**Fastroller**



**Pro**  
**Dive Boat**

- 👉 **YACHT TENDERS**
- 👉 **PROFESSIONAL DIVE BOATS**
- 👉 **RIBs & ROLL-UPS**
- 👉 **LIFERAFTS**
- 👉 **SALES AND SERVICE**



**ZODIAC**

CALL TODAY FOR **LOWEST PRICE OF THE YEAR!**

**Tim's Zodiac Marine**  
45570 Industrial Place #10, Fremont, CA 94538  
**(510) 438-9881**



**NOW AVAILABLE**



**AVON INFLATABLES**



part isn't really there. That's what they try to fix when they modernize an old IOR hull, filling in that big hollow — but the stern is still too narrow and too high up to be as fast as a modern stern."

"Plus they penalized stability too much," added the tactician. "And headsail and spinnaker area not enough. We had fat boats with tall masthead rigs and those ribbon mainsails, and not enough ballast down low."

"I remember them well," I said. "You had to be a really good downwind driver to race on the Bay back then. You kids have it easy!"

"Then computer technology saved us," noted the big Aussie, "by generating the Velocity Prediction Program that made MHS, the Measurement Handicap System, possible. That was the first rational rating matrix, and it became IMS, the International Measurement System."

"Cheap computing was necessary for IMS, but not for the VPP," argued Lee. "That was done on big iron at M.I.T. But like, computers were necessary to make full lines measurement practical.

"There's gotta be better ways to get at waterline length without girth stations or a million hull measurements," said the foredeck crew. "I've seen a measurer take all day to do one boat."

### HOW TO FIX PHRF

- Divide into PHRF-A and PHRF-B; PHRF-A is only for accurately established ratings based on a one-design class database.
- Organize races into divisions of similar type boats where possible.
- Issue three-number ratings: Summer Bay (for Central Bay), Winter Bay (comparable to ratings from other light-air regions) and Downwind Ocean (similar to Pacific Cup adjustments).
- Liberalize allowances for roller furling, dodgers, limited sail inventories, etc. in PHRF-B to accommodate the cruiser-racer fleet.

"MORC, the Midget Ocean Racing Club, had a reasonable system," said Lee. "They go up some small percent of LOA from the waterline, and then mea-

sure the transom width at that height, and then part of that transom width is added to the waterline length. It was a reasonable compromise between simplicity and appropriate penalties for wide sterns, even though the wide sterns eventually took over as boats got lighter. IRC is, like, a step backwards. It just measures the aft overhang to the bottom transom corner, and the height of the transom corner above the water, and then they apply their secret formula. The problem is that it never even looks at the width of the stern. There are supposed to be different formulas for boats of different types, but it's all a black box and only the designers seem to know how it works inside."

"But you know, IRC is doing a lot of things right," the tactician insisted. "I especially like the multi-tiered rating system, where you can measure your boat yourself for a basic rating, or take a one-design rating, or use stock measurements. But then for the 'endorsed' ratings there are actual weighings and certified measurers.

"PHRF could take a page or two from

*Discover*  
**Brisbane Marina**

**GREAT LOCATION!** Just minutes to Central Bay sailing.  
**GREAT RATES!** \$5.90/foot!  
**GREAT FACILITIES!** All concrete docks.  
Newly constructed bathrooms and laundry rooms.  
**KAYAK STORAGE!** \$25 per month.

From Hwy. 101, take the Sierra Point Parkway exit and follow the signs to the marina.

400 Sierra Point Parkway  
Brisbane, CA 94005  
(650) 583-6975  
[www.ci.brisbane.ca.us](http://www.ci.brisbane.ca.us)  
[harbormaster@ci.brisbane.ca.us](mailto:harbormaster@ci.brisbane.ca.us)

# MAX EBB

that playbook," Lee suggested.

"How so?" I asked.

"PHRF is also a single-number rating, and has some of the same shortcomings. I mean, like, PHRF is great for handicapping a Cal 25 against a Newport 30, or a Santa Cruz 27 against an Olson 30. Or even a Melges 24 against an Antrim 27. That's what it was invented for — to compare classes of similar characteristics when there are lots of sisterships out racing. When it's used like that, two problems go away: First, there's enough data to get reasonably representative race results without so much of a crew skill factor messing it up. And second, the performance envelopes of all the boats are sort of the same shape. So like, you don't have one boat winning just because it was light air, or another boat winning just because it was a mostly reaching race, and like that."

"But how are you going to include everyone who wants to race if you limit PHRF just to those more accurate applications of the ratings?"

"That's why it has to be a two-tiered system," she said. "Have a 'PHRF-A' fleet for classes of boats with well-established ratings. They could only race against boats of roughly similar type."

"And what about the beer can racer with a one-of-a-kind cruising boat or an

it fairly when you have a Rub-A-Dub 39 and a Hot-Stuff 40. They can race together, but it should be in the B fleet where you expect the level of competition to be a little lower and you get more natural scatter in the finish times. Ratings don't have to be as precise as the beer can level, but for a major regatta, the smaller differences become much more important."

"Think we should stay with a single-number PHRF rating?"

"If you count the Pacific Cup correction as the downwind ocean PHRF rating, we already have a two-number system, sort of. Actually I think PHRF certs should include three numbers: Summer Bay, based on summer

Cityfront conditions; Winter Bay, which would be for more variable wind speed and for conditions comparable to what most of North America races in; and Downwind Ocean. Race organizers could choose an appropriate mix of the three ratings based on climatological expectations.

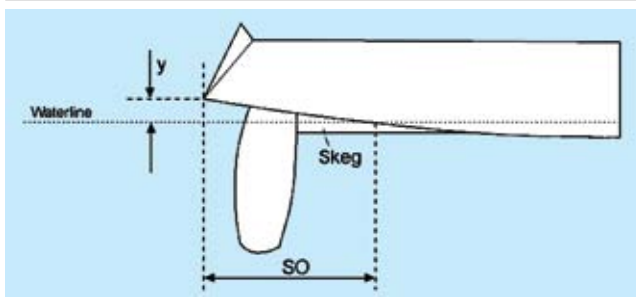

**IRC's two-dimensional overhang measurement is oblivious to differences in transom or hull beam at the stern.**

oddball custom racer?"

"They would have to settle for PHRF-B. Sorry, but there's like, no way to do



**Keelboat Certification System**

*Let us show you the ropes*



Find a US SAILING accredited school near you:  
call 1-800-USSAIL-1 or visit  
[www.sailingcertification.com](http://www.sailingcertification.com)

Photo courtesy of Emily Black Studios

You dream of learning to sail and charting a course to an adventure of your own. At US SAILING, superior instruction and hands-on training come together under the direction of the most qualified instructors at the country's top sailing schools.

**Accomplished sailors start here.**

**AQUAMARINE**  
*Watermakers Since 1987*

**SPARKLING FRESH WATER, POWER, AND REFRIGERATION FROM THE SEVEN SEAS**

110 VOLT / BELT DRIVE	HYDRAULIC	
		
	MODULAR KIT	
UPGRADE MOUNT	316 S/S REMOTE PANEL	12 VOLT DC

AquaGen combines the quality, simplicity & reliability of AquaMarine, Inc. watermakers with the durability of the Kubota 150 amp 12V diesel generators. This compact low fuel consuming AquaGen is a powerhouse, capable of producing up to 150 amps, and 8 up to 62 GPH of fresh potable water from any water source. Make fresh water, refrigeration, and also charge your batteries all at the same time! A hydraulic pump may also be added to run your dive compressure, windless, bow thruster, or emergency bilge pump. Ideal for longterm cruisers or weekend wanderers. We custom engineer our systems to fit any size vessel or cabin site. Electric, Hydraulic, or Belt Driven Modular Kits are also available. Visit our Website for more information.

QUALITY AT AFFORDABLE PRICES.  
LIFETIME WARRANTY ON PUMP HEAD AND PRESSURE VESSELS.

**AquaMarine, Inc., 58 Fawn Lane (P.O. Box 55) Deer Harbor, WA 98243 USA**  
(800)or(360) 376-3091 Fax (360) 376-3243

[www.aquamarineinc.net](http://www.aquamarineinc.net)



# — LOOKING FOR A FIX

"So you'd use this PHRF-A instead of a measurement rule for major events?" I asked.

"Major on the club level," she said. "We still need a good measurement rule for the big kids because big boats hardly ever have enough of a one-design class to establish a rating to PHRF-A standards."

"So we're back to IRC."

"Or MHS, which begat IMS, which begat Americap, which begat ORR," added the foredeck crew.

"Or the new ORC-International," added Lee. "Any of the three contenders — IRC, ORR or ORC-International could win market share and become the next real international rule if they went open source, ended the secrecy, and allowed local jurisdictions to administer it. I mean, that's one of the reasons there are 20,000 PHRF certificates and only 700 IRC racers in the States. Ratings for local races should not have to go back east through the Newport bottleneck."

"But IRC is an empirical rule," said the tactician, "whilst ORR and ORC-I are VPP-based."

"That's the big myth," answered Lee. "Even a basic waterline length rule is VPP-based, although the VPP is a very simple one in that case. And like, every VPP-based rule is developed from empirical data. It's a false dichotomy, except for PHRF-A and Portsmouth, which really are empirical ratings. It's the secrecy of the formula that really sets IRC, ORR and ORC-I apart from previous rules, and why I think they belong in the same category."

"Without the secrecy," I said, "wouldn't designers be able to exploit IRC even more than they do now?"

"The designers already know exactly how it works," claimed Lee. "And there's a simple fix: Don't rate any boat that's designed after the latest version of the rule. Sure, some top-end programs get put out of business, and the designers would scream, but like, do we care more about a few high rollers or the broad base of existing and potential competitors who don't have new boats designed

every couple of years? I think the base is totally more important than the tippy top of the crumbling pyramid."

"Coming back to your PHRF-A scheme," suggested the tactician, "if the measurement rule was working well enough, a measured boat might get into PHRF-A on the basis of its measured rating."

"I'm going to see what's left of that salmon," said Lee, looking at her empty plate.

My plate was also empty, so I joined Lee at the buffet table, now only moderately crowded.

The starboard side of the fish had been stripped clean to the frames and keel, but after we tacked over to port we found some large areas aft that had been overlooked.

"A good example of a long narrow stern," I remarked. "This fish would rate horribly under IRC."

"For sure, Max," she agreed as she tasted a forkful from the tail. "But at least it died for a good cause."

— max ebb

**New Member Showers and Laundry Facilities Now Open!**

# Emeryville Marina

ON THE BAY

**NEW SLIPS!**  
Now taking reservations  
40' to 60' - available  
Fall/Winter 2008

*When you call Emeryville Marina Home...  
...call this your backyard!*

**Free Wi-Fi and Video Surveillance**

Slips from 20-65 ft  
Full Amenities - including  
Fuel Dock & Pumpout Station

**(510) 654-3716**  
[www.emeryvillemarina.com](http://www.emeryvillemarina.com)

**MARINAS**  
International

# THE RACING

In this month's Racing Sheet, we bang all the corners. From the **Summer Keelboats to 18-ft Skiffs** and the **Ronstan Bridge to Bridge** racers we move on to some big boats and a prelude to the Rolex Big Boat Series, the **Aldo Alessio Perpetual Trophy Regatta**. We go left, down to Santa Cruz for the **Santana 22 Nationals** and then back right, for the **Snipe Nationals** and YRA **Second-Half Opener**. Finally we check in at the **505 PCCs**, and go way left for the **2008 Olympic Regatta**, and back way right for a final race note from the Gorge. Enjoy!

## Summer Keelboat Regatta

Tom Coates just keeps on winning in the J/105 class. The winner of the last four Key West Race Weeks in the class, as well as last year's North Americans, added the 2008 PCCs to his trophy collection August 9-10 at the San Francisco YC's Summer Keelboat Regatta, which doubled as the PCCs for the class.

Sailed on the Circle in breeze into the high 20s, there was plenty of really tight action in the division with some photo finishes and bust roundings.

Coates' *Masquerade*, with crew Will Baylis, Mark Chandler, Tim Scherer, Jen Browne-Synder and Steve Marsh, sailed consistently, never finishing out of the top six to win by six points. Chris Perkins, Coates' regular tactician at out-of-town events, took second with *Good Timin'*.

Bill Riess' *Elan* won the five-boat Express 37 division at the regatta, posting a 1,3,1,1,1, five points ahead of Bartz Schneider's *Expeditious*.

In the two-boat 1D35 class, Gary

## SUMMER KEELBOAT REGATTA AND J/105 PCCs.

(SFYC, 8/9-10, 10r/1t)

J/105 — 1) **Masquerade**, Tom Coates, 16 points; 2) **Good Timin'**, Chris Perkins, 22; 3) **Donkey Jack**, Scott Sellers, 23; 4) **Aquavit**, Tim Russell, 34; 5) **Convexity**, Don Wilson, 35. (33 boats)

EXPRESS 37 — 1) **Elan**, Bill Riess, 7 points; 2) **Expeditious**, Bartz Schneider, 12; 3) **Golden Moon**, Kame Richards, 12. (5 boats)

1D35 — 1) **Diabalita**, Gary Boell, 6 points; 2) **Alpha Puppy**, Alex Farell, 9. (2 boats)

complete results at: [www.sfyrc.org](http://www.sfyrc.org)

## 18-ft Skiff Regatta

The young Australian team of Seve Jarvin, Sam Newton and substitute Tom Clout — each 22 years old — showed why they're the reigning world champions of the 18-ft skiff class when they beat the competitive field of 11 teams at the St. Francis YC's International 18 Skiff Regatta, August 12-16.

Going into the final day, the trio held a slight advantage over top American contender *Team Harken*, sailed by Howie Hamlin, Mike Martin and Paul

Allen. With a first in the penultimate race, Jarvin, Newton and Clout sailed their red *Gotta Love It* to a four-point lead over *Team Harken*. From there the trio played it safe, flogging their kite and successfully resisting the temptation to push the boat on the runs.

"Coming down the last run, we were itching to light it off," said Clout. "But we had to sail conservatively."

That was a sound strategy considering the fleet had sailed in some pretty nuclear conditions that the whole week.

"Over the seven years I've done this, this year was the windiest with the most ebb," said the Bay Area's *Team Cabot Cheese* skipper, Patrick Whitmarsh. "Everyone had at least one letter score."

The letters he's referring to are D, N,



LATITUDE/ROB

and F.

The slogan on *Panasonic's* main said "Ideas For Life." What would have been more appropriate though, is "Ideas For Hanging On For Dear Life," as the fleet battled the gnarly conditions.

Breakdowns were common, with everything from prods to rigs suffering damage. *Team Harken* broke their rig at the end of day two when a shroud failed, and only a last minute loan from Philippe Kahn's *Team Pegasus* — which wasn't sailing the event — inventory of gear saved their regatta.

"We owe Philippe a big thank you," Hamlin said, explaining that failing to do his normal thorough check of the gear cost him his spar. "Most of the stuff, you can see before it goes. If you get careless that's what happens."

The brutal conditions took their toll on sailors as well as boats. *Team Cabot*

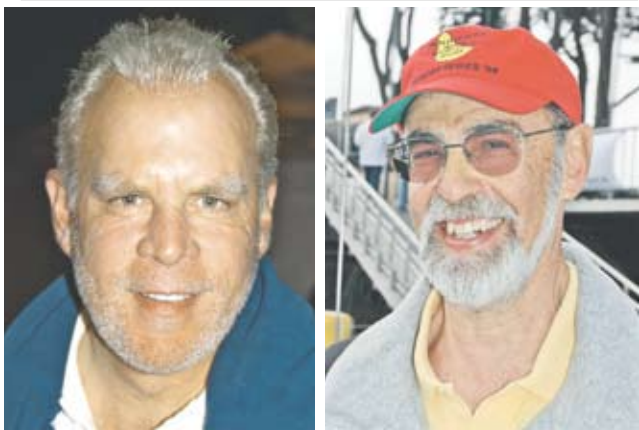

Summer Keelboat winners Tom Coates (l) and Bill Riess

Boell's *Diabalita* won all but one race over Alex Farell's *Alpha Puppy*.

We're not sure if those two stuck to the fleet racing rules but it must have been kind of fun to have your own match race with no other flights to worry about, although umpires would have been nice.





*There was plenty of breeze on the Circle at the J/105 PCCs, held concurrently with the San Francisco YC's Summer Keelboat Regatta. The Express 37s and a pair of 1D35s joined in the fun also.*

Cheese's forward-hand Joe Penrod described the scene on the beach after they broke their prod on day three.

"We got all motivated, and said 'We're going to fix this carbon pole,'" Penrod said. "Next thing you know, we're all asleep."

Hamlin was pleased with *Team Harken's* regatta and realistic about their result.

"*Gotta Love It* sailed a great regatta," he said, adding that the Aussies' biggest advantage is the practice they get at home. "They sail the boats every Sunday for six or seven months down there."

Ideally Hamlin would like to see that kind of scene in the states and on the

Bay.

To that end, he's long turned over his older boats — he usually keeps two — to the Bay's Skiff Sailing Foundation at bargain prices. But the problem lies in a lack of boat owners beyond the foundation and Dan Brandt's *Natural Blues* team.

"Five years ago, there were no sailors," Hamlin said. "Now there aren't enough owners. I can't believe the money people spend dinking around on their keelboats when they could be doing this."

Allen said that sailing these boats is doable for fit people.

"It's within reach," he said. "The key is looking at it as learning another sport, like kiteboarding or windsurfing, not learning to sail a different boat."

Hamlin estimated he's owned at least three-quarters of the fleet at one point or another and the weekend before sold

his World Championship-winning boat to the Skiff Sailing Foundation at a sweetheart price. Chad Freitas, one of the Foundation's core members, was stoked on the acquisition.

"It's great to finally have an 'A' boat," he said, explaining that the Foundation's boats are pretty tired and uncompetitive with the newer boats, but still great for giving neophytes a new experience, mainly through their 'sail-a-skiff day's. "We introduce probably about 300 people a year to sailing skiffs."

The Bay is pretty much the only place in the States you'll find that, as well as a core-group of young diehards carrying the torch.

And the major attraction of the skiffs? Hamlin explained it best.

"The runs we had this week were phenomenal," he said, his face lighting up. "They're the kind of thing where, weeks later, you wake up in the middle of the night and go aaahhhh. . . ."

#### INTERNATIONAL 18 SKIFF REGATTA (SiFYC, 8/16, 10r/1t)

1) **Gotta Love It**, Jarvin/Newton/Clout, 12 points; 2) **Harken**, Hamlin/Martin/Allen, 15; 3) **SLAM**, Rollerson/Noble/Mann, 26. (11 boats)

complete results at: [www.sfyyc.org](http://www.sfyyc.org)

#### Ronstan Bridge to Bridge

Nipping at the heels of the reigning 18-ft skiff world champions *Gotta Love It* for the first few minutes of the 11th annual Ronstan Bridge to Bridge Race, Howie Hamlin, Mike Martin and Paul Allen on *Team Harken* seized the lead when the bright red boat augered in off Crissy Field.

The trio rode a knock all the way down the Cityfront, finishing the five-and-a-half-mile course from the Golden Gate to the Bay Bridge in 17 minutes and 52 seconds on August 15.

Their win marked the first time in seven years that something other than a kiteboard has won this battle of the disciplines. Last year's winner, the Bay Area's Chip Wasson, was the first kiter to finish this year, some 37 seconds behind *Team Harken*. Almost five minutes later, windsurfer Al Mirel took the Formula Board honors.

The breeze ranged from the mid-20's along the fog line off Fort Mason to the mid-teens past Pier 39. Coupled with a two-plus-knot ebb, the Bay brought plenty of punch for the 44-strong fleet. Just 26 sailors finished.

#### RONSTAN BRIDGE TO BRIDGE (SiFYC, 8/15)

1) **Team Harken**, Skiff, Hamlin/Martin/Allen; 2) **Pink 1**, kite, Chip Wasson; 3) **Blue 0**, kite, John Gomes; 4) **Red 6**, kite, Anthony Chavez; 5) **Active**



# THE RACING



RICH ROBERTS



PETER LYONS/WWW.LYONSIMAGING.COM



ERIK SIMONSON/WWW.H2OSHOTS.COM

ALL PHOTOS LATITUDE/ROB EXCEPT WHERE NOTED

**Air, Skiff, Searle/Wilsdon/Massie.** (26 boats)  
complete results at: [www.stfyc.org](http://www.stfyc.org)

## Aldo Alessio Regatta

Mike Garl's Beneteau 40.7 *White Dove* won the IRC division at St. Francis YC's Aldo Alessio Perpetual Trophy Regatta and with it, the West Coast IRC Cham-

pionship. The regatta was held August 1-3, with a 28-mile ocean race to the Lightship and back on Friday, two buoy races on Saturday and a Bay tour on Sunday sailed in breeze ranging from 15-30 knots.

Garl left the regatta pleased with a class win in IRC C, but thinking he'd

finished second in the West Coast Championship to Ashley Wolfe's TP 52 *Mayhem*, which won the Aldo Alessio Trophy for the ocean race on Friday, and IRC A on a countback after tying with Lani Spund's SC 52 *Kokopelli*?. *Mayhem* finished with a 1,1,4,2 over the weekend against a tough field that also included





**Clockwise from above right — Tom Clout of 'Gotta Love it' gets a vital signs check from competitor Brett Van Munster after a gnarly week . . . of doing this all day long; 'Panasonic' gets airborne going upwind; Howie Hamlin and Paul Allen performing a rig-check; 'Team Harken' lifting off; (l-r) Hamlin, Martin and Allen after winning the Bridge to Bridge; Chad Freitas shows what happens to rigs when you don't complete your gybes in a timely manner; rounding a leeward mark; the "Natural Blues" team was a bare-bones effort; this was a common sight during the week, even for the winners.**

Sy Kleinman's Schumacher 54 *Swiftsure II* and Bill Turpin's R/P 77 *Akela*.

But a few days later they'd come to find out that they did better than they'd

thought.

"It came as a big surprise to us," Garl said. "The boats were all divided into three classes and we never really keep

track of how the whole group is matching up. We thought *Mayhem* had won, and a couple days later John Craig called and told us there'd been a mathematical error



# THE RACING

and we'd won."

A pleasant surprise for sure, but according to Garl, it was no fluke.

"We had a great regatta and a terrific crew," he said. "Our tactician, John Stewart, did an amazing job, I give a lot of credit to him and his experience and ability in getting us around the Bay."

With the help of Doyle Sails' Rusty Canada on trim, Nate Ballard on main trim, long-time crewman Jean-Philippe Perot, Scott Finger, 'G-Man', and Zack Zwitter, *White Dove* is leading the Northern California IRC series going into the final series event, the Rolex Big Boat Series.

Steve Madeira's J/120 *Mr. Magoo* took home the regatta's only one-design trophy with straight bullets in the six-boat division.

Talking with Garl, it quickly becomes apparent that he really enjoys his sailing. The peninsula-based painting contractor hailing from Sequoia YC bought the boat in 2001.

"Scott Easom comissioned the boat and helped me immensely in training the crew," Garl said. We sailed PHRF for a couple years, and in 2003 won our class at Big Boat Series under Americap."

From there the *White Dove* program picked up in intensity, jumping into the IRC fray when it replaced Americap as the rule of choice on the Bay.

"We were glad to see IRC come along because we feel that it really gives us a fair chance," Garl said. "It's kind of nice that a pretty-stock, production boat can stack up to all the marvelous newer boats like the TP 52s and *Kokopelli*."

Brad Copper's Tripp 43 *TNT* used the same scoreline as *White Dove* to win Division B, finishing two points clear of

John Siegel's Wylie 42 *Scorpio*. *TNT* is a masthead-rigged IMS design that Copper says seems to do fairly well under IRC.

"In general, IRC seems to rate most boats fairly, whether production or custom," Copper said. "With my limited exposure to IRC racing, it seems to be fair. My approach is to have faith in the rating system, and to focus on sailing the boat, tactics, and strong crew work. The rating should take care of itself if the IRC rule has merit, which I believe it does."

Copper, who's in the semiconductor business, sails out of Richmond YC and in only his first year campaigning the boat, now sits in third overall in the San Francisco Bay IRC Championship Series, behind *Scorpio* and *White Dove* — provided that at least three races are completed at the Rolex Big Boat Series, where the season's throwouts will come into effect.

Originally from the Midwest, Copper sailed competitively on the Great Lakes in various one-design classes and under rating systems before taking a break from sailing.

"Coming in after several years with a fresh perspective has been a lot of fun and very rewarding," he said. "A first-year campaign faces numerous challenges with the boat, the equipment, the crew, etc. I'm fortunate to have good core crew, the involvement of several RYC members, and the support of some accomplished local sailors like Seadon Wijzen, Peter King, Jeff Thorpe, and Steve Taft."

The Big Boat Series is the final event on the SF Bay IRC season calendar, and right now the season standings are close.



ALL PHOTOS PETER LYONS/WWW.LYONSIMAGING







J/120 (3r/0t) — 1) **Mr. Magoo**, Steve Madeira, 3 points; 2) **Chance**, Barry Lewis, 8; 3) **Dayenu**, Donald Payan, 9. (6 boats)  
complete results at [www.stfyc.org](http://www.stfyc.org)

### Santana 22 Nationals

Santa Cruz sailor and Tuna institution Ernie Rideout has added another Santana 22 National Championship to his lengthy sailing resume — 79 years lengthy to be exact. That's 79 years of sailing mind you, because when Rideout took a comfortable 11-point win in Santa Cruz on July 27, he was 90 years old.

While we were in Hawaii meeting arrivals in Kaneohe and Hanalei, Rideout and crew Ray Pingree and Phil Worthen on *Maybe*, tore through the 19-boat fleet with a scoreline of two thirds and three bullets in the five-race series.

Talking with Rideout, you'd never know just how much success he's had in that nearly 80 years of sailing, because he's not really the toot-your-own-horn kind of guy, as far as we can tell.

Earlier this year, this diehard supporter of the Tuna fleet told us about his motivation to keep sailing: "It keeps us young and occasionally we can say, 'old guys rule.'"

And rule he did.

2008 SANTANA 22 NATIONALS  
(Santa Cruz YC, 7/25-27, 5r/0t)

1) **Maybe**, Ernie Rideout, 9 points; 2) **Rick's Place**, Larry and Bob Comstock, 20; 3) **Carlos**, Jan Grygier, 20. (19 boats)

### Second-Half Opener

Ninety boats in 22 divisions showed up for the Saturday portion of YRA's Second Half Opener on July 26-27 — an excellent turnout considering more than 80 boats and several hundred sailors had departed the Bay for Hawaii earlier in the month in the Pacific Cup and Singlehanded TransPac.

Hosted by Encinal YC, the second-halfers sailed out of the Bay to Point

**Fast and Furious action at the Aldo Alessio Perpetual Trophy Regatta — Left, everything from Bill Turpin's mighty 'Akela' to Mike Garl's giant slaying 'White Dove' competed for the West Coast IRC championships. Above, 'Alpha Puppy' with plenty of pace on. Above right, 'Dayenu' took third in the only one-design division in the regatta, J/120s. They weren't the only boat to get sideways.**

Garl says *White Dove* is ready.

"We're leading by a slim margin, so we've got to do well at Big Boat Series," he said. "But, we feel like we're doing really well, and it's just a lot of fun. We've had some terrific practices, the attitude is up, and everyone's having fun — we've got a lot of momentum going for us."

ALDO ALESSIO PERPETUAL & WEST COAST  
IRC CHAMPIONSHIP (StFYC, 8/3, 4r/0t)

IRC A (4r/0t) — 1) **Mayhem**, TransPac 52, Ashley Wolfe, 8 points; 2) **Kokopelli<sup>2</sup>**, SC52, Lani Spund, 8; 3) **Swiftsure**, Schumacher 54, Sy Kleinman, 13. (4 boats)

IRC B (4r/0t) — 1) **TNT**, custom Tripp 43, Brad Copper, 5 points; 2) **Scorpio**, Wylie 42, John Siegel, 7; 3) **Howl**, Sydney 38, Peter Krueger, 14. (7 boats)

IRC C (4r/0t) — 1) **White Dove**, Beneteau 40.7, Mike Garl, 5 points; 2) **Tupelo Honey**, Elan 40, Gerard Sheridan, 8; 3) **Phantom Mist**, Beneteau 40.7, Gary Massari, 15. (6 boats)

# THE RACING

Bonita and back under gloriously clear blue skies and a healthy 15 knots of breeze.

Fifty-one boats returned on Sunday to complete the weekend-long event with a buoy race that started and ended off Treasure Island.

The 'big' fleets on both days were the Party Circuit divisions, comprising 15 of the 22 divisions on Saturday and 11 of 15 on Sunday. YRA's Party Circuit is aimed toward fun, with participants required to show up for only three events all summer: the Great Vallejo Race (May 3-4), Summer Sailstice Regatta (June 21-22) and the Second Half Opener. To qualify for a season trophy, PC boats — and we don't mean 'politically correct' — must complete at least one race on each of these weekends. As added incentive, each of these three events hosts a party on Saturday night — which is where the idea got its name. About two-thirds of the boats on each day were competing under the PC banner.

Richard Leslie's party animals on the Melges 32 *Southern Cross* led the fleet across the finish line Saturday, completing the 22-mile lap in 3 hours, 26 minutes. That was also good enough for a first in PC Division G. On corrected time, Bill Chapman's veteran Catalina 27



BUNNY ARMS/WWW.GEOCITIES.COM/ALLACTIONPHOTOS/

*Latin Lass* topped both the PC SF 198-rater division, and the fleet overall.

#### SATURDAY

PC MULTIHULL — 1) **Origami**, Corsair 24; 2) **Three Sigma**, F-27, Christopher Harvey. (2

**Ernie Rideout** (above right) sails *'Maybe'* to a second *Santana 22 National* title in his home waters off Santa Cruz — at the age of 90. He and crew **Phil Worthen** and **Ray Pingree** finished 11 points clear of second place after five races

## BOX SCORES

If you think the kids going back to school signalled the impending end of summer, perhaps a more frightening signpost is that most of the Beer Can series are over or nearly over. For many of those local evening series, the results here indicate overall winners.

Want to give your event the best possible chance to 'break out' of box scores and be elevated to a mini-article in *The Racing Sheet*? Then be sure to email or post as much information as possible about that event. At the very minimum, it should include the boat name, boat type and boat owner's full name for each boat in each division. If it's a series, it should include placings and points in each race and a cumulative score. You get extra credit — and our undying appreciation — if you include course lengths, wind direction and strength, a few notes about who did what to whom — and photos.

#### RUNNING OF THE BULLS

(*El Toros* — *Elkhorn YC*, 8/16, 3r/1t)

SENIOR A — 1) **Cygnus**, Art Lange, 2 points; 2) **Totyot**, Greg Morrill, 6; 3) (no name), John Pacholski, 6. (9 boats)

SENIOR B — 1) **Margot**, David Nichols, 2

points; 2) **Funny**, Aaron Gregg, 4; 3) **Timshell**, Disun Den Das, 6. (4 boats)

JUNIORS — 1) **Endeavour**, Mackenzie Cook, 2 points; 2) **Toro Serpiente**, Pippin Seales, 4; 3) **Wave**, David Tang-Murray, 5. (6 boats)

#### OLSON 30 NATIONALS

(*Channel Islands YC*, 7/17-20, 9r/1t)

1) **Blue Star**, Larry Spencer/Todd Downey, 11 points; 2) **Shadow**, Tom and Ray Corbett/Joe Brown, 20; 3) **Perfect Balance**, Richard Sharpe, 29. (9 boats)

#### LASER PACIFIC COAST CHAMPIONSHIPS

(*Monterey Peninsula YC*, 8/1-3, 9r/1t)

LASER — 1) Brad Funk, Clearwater YC (FL), 14 points; 2) Abe Torchinsky, Royal Vancouver YC, 34; 3) Chris Dold, Royal Canadian YC, 41. (59 boats)

LASER RADIAL — 1) Jennifer Spaulding, Royal Vancouver YC, 26 points; 2) Mateo Vargas, St. Petersburg YC, 53; 3) Claire Merry, Royal Canadian YC, 55. (47 boats)

LASER 4.7 (Jr. Division, 8r/1t) — 1) Mary Hall, St. Petersburg YC, 7 points; 2) Caroline Wallace, St. Petersburg YC, 14; 3) Stephen Katz, MPYC, 20. (3 boats)

#### WEDNESDAY NIGHT WOODIES SERIES

(*StFYC*, 10r/0t\*)

KNARR — 1) (no name), Glidewell/Frenchy/

Perkins, 23 points; 2) **Svenkist**, Sean Svendsen, 28; 3) **Benino**, Dahm/Anderlini, 46. (14 boats)

FOLKBOAT — 1) **Windansea**, Don Wilson/David Wilson, 23 points; 2) **Josephine**, Eric Kaiser, 27; 3) **Polperro**, Peter Jeal, 42. (15 boats)

IOD — 1) **Youngster**, Ron Young, 23 points; 2) **Undine**, Adam Wheeler, 24; 3) **Xarifa**, Paul Manning, 25. (5 boats)

#### BEER CAN RESULTS

FRIDAY NIGHT SERIES (GGYC, 7r/2t\*)

SPINNAKER — 1) **Jam Jam**, Neil Ruxton, 5 points; 2) **Crazy Jane**, Doug Carroll, 12; 3) **One Trick Pony**, Peter Szasz, 15. (5 boats)

NON-SPINNAKER — 1) **Late Harvest**, Modern Sailing Academy, 9 points; 2) **Sanfu**, Maurice Quillen, 10; 3) **Mary Belle Bright**, Bright Winn, 10. (6 boats)

Complete results: [www.ggyc.com](http://www.ggyc.com)

FRIDAY NIGHT SERIES (CYC, 8r/1t)

J/105 — 1) **Tiburón**, Steve Stroub, 8 points; 2) **Roxanne**, Charles James, 10; 3) **Alchemy**, Walter Sanford, 19. (6 boats)

SPINNAKER 2 — 1) **Good and Plenty**, Soverel 33, Will Baylis, 12; 2) **Youngster**, IOD, Ron Young, 19 points; 3) **306LP**, IOD, Shawn Davies/Jen Dailey, 27. (12 boats)

SPINNAKER 3 — 1) **Big Wow**, Rhodes 19, Tom Royall, 7 points; 2) **Wuda Shuda**, Soverel 26, Craig Page, 14; 3) **Vague Unrest**, Rhodes 19,





Thomas Bruce; 3) **Bufflehead**, Stuart Scott. (4 boats)

ALERION EXPRESS 28 — 1) **Ditzy**, Ralf Morgan; 2) **Lisbeth**, Michael Land. (2 boats)

SF 180 — 1) **Goose**, Catalina 30, D. Michael Kastrop; 2) **Zeehond**, Newport 30-2, Donn Guay; 3) **Missy B**, Catalina 30, Russell Calvery. (6 boats)

EXPRESS 37 — 1) **Stewball**, Bob Harford; 2) **Phat Jack**, Robert Lugliani; 3) **Elan**, Bill Riess. (4 boats)

ISLANDER 36 — 1) **Freedom Won**, John Melton. (1 boat)

OLSON 25 — 1) **Shadowfax**, Mark Simpson; 2) **Synchronicity**, Steve Smith; 3) **Shark On Bluegrass**, Falk Meissner. (5 boats)

SANTANA 22 — 1) **Meliki**, Tom Montoya. (1 boat)

PC SF 198 — 1) **Latin Lass**, Catalina 27, Bill Chapman; 2) **Star Ranger**, Ranger 26, Simon James; 3) **Sagitta**, Islander 28, Walter George. (5

boats)

PC J/105 — 1) **Ultimatum**, Musto Gunan. (1 boat)

PC EXPRESS 27 — 1) **Freaks on Leash**, Scott Parker; 2) **Wile E. Coyote**, Dan Pruzan. (2 boats)

Phil Simon, 16. (8 boats)

NON-SPINNAKER 1 — 1) **QE3**, Tartan 10, Tom Perot, 8 points; 2) **Q**, Schumacher 40, Glenn Isaacson, 14; 3) **Basic Instinct**, Elliott 1050, Jan Borjeson, 26. (14 boats)

NON-SPINNAKER 2 — 1) **Summer Sailstice**, Ranger 33, John Arndt, 7 points; 2) **Mahoo**, Colgate 26, Michael Johnson, 13; 3) **Swellbound**, Colgate 26, David Hayward, 18. (8 boats)

NON-SPINNAKER 3 — 1) **Chica**, Cal 20, Ted Goldbeck, 9 points; 2) **Tension II**, Cal 20, John Nooteboom, 16; 3) **Rubber Biscuit**, Santana 22, Rich Korman, 17. (10 boats)

Complete results: [www.cyc.org](http://www.cyc.org)

#### SPRING SUNSET SERIES (SYC, 5r/1t)

SPINNAKER — 1) **Gammon**, Tartan 10, Jeff Hutter, 5 points; 2) **Lynx**, WylieCat 30, Steve Overton, 9; 3) **Nothing Ventured**, Melges 24, Duane Yoslov, 12. (7 boats)

J/105 — 1) **Streaker**, Ron Anderson, 4 points; 2) **Wife Not Happy**, Edward Holl, 15; 3) **Swoosh**, Howard Bentley, 17. (4 boats)

NON-SPINNAKER — 1) **Grey Ghost**, Hanse 342, Doug Grant, 11 points; 2) **True North**, Baltic 42, Jeff Dunnivant, 15; 3) **Venture**, Jeanneau 49, Michael Chobotov, 16. (23 boats)

MULTIHULL — 1) **Origami**, Corsair 24, Ross Stein. (1 boat)

Complete results: [www.syconline.org](http://www.syconline.org)

#### BEER CAN WEDNESDAYS (Sequoia YC, 8/20)

1) **Mirth**, Catalina 34, Rick Gilmore; 2) **Timbaktu**, Freedom 32; 3) **Metridium**, Catalina 42,

John Graves.

#### SUMMER TWILIGHT SERIES (EYC, 3r/1t)

DIVISION 1 (PHRF <126) — 1) **Rascal**, Rui Luis, 2 points; 2) **Audacious**, Scott Christiansen, 5; 3) **Spirit Of**, Bill Mohr, 5. (6 boats)

DIVISION 2 (126-160) — 1) **Double Trouble**, Kevin Durant, 2 points; 2) **No Moore**, Bernard Saggese, 3; 3) **Wile E. Coyote**, Dan Pruzan, 5. (6 boats)

DIVISION 3 (>161) — 1) **Bewitched**, Laraine Salmon, 2 points; 2) **My Tahoe Too!**, Steve Douglas, 3; 3) **Alpha Centauri**, Shelley Bliss, 6. (7 boats)

NON-SPINNAKER — 1) **Blueberry**, John Foster, 2 points; 2) **Iskara**, Paul Mueller, 3; 3) **Mistral**, Peter Bellows, 5. (4 boats)

COLUMBIA 5.5 — 1) **Tenacious**, Adam Saded, 2 points; 2) **Jaguar**, Keith Rarick, 4; 3) **Alert**, Liem Dac, 7. (3 boats)

Complete results: [www.encinal.org](http://www.encinal.org)

#### THURSDAY NIGHT SERIES (Benicia YC, 8/14\*\*)

A FLEET — 1) **Bluefin**, Noble Griswold; 2) **Cilaxn**, Tim Merrill; 3) **Bay Loon**, Grant Harless. (5 boats)

B FLEET — 1) **Gaijin**, Pete Adams; 2) **Flash**, Brett Nelson; 3) **Puppeteer**, Thom Davis. (3 boats)

C FLEET — 1) **Allegre**, Chris Klein; 2) **Alte Liebe**, Jerry Martin; 3) **Katie Bay-B**, Mike Munn. (5 boats)

Complete results: [www.benicaiyachtclub.com](http://www.benicaiyachtclub.com)

\*\* results are for noted date only

boats)

PC IOR WARHOSE — 1) **Infinity**, Holland 47, Gary Gebhard. (1 boat)

PC NON-SPINNAKER — 1) **Lassie**, Pearson 28, Michael Farrell. (1 boat)

PC G (PHRF <66) — 1) **Southern Cross**, Melges 32, Richard Leslie; 2) **Jeannette**, Frers 40, Henry King; 2) **Savage Beauty**, Flying Tiger, John LyMBERG; 4) **White Fang**, Beneteau 40.7, Mark Howe; 5) **Diablita**, 1D35, Gary Boell. (14 boats)

PC H (69-93) — 1) **Jarlen**, J/35, Robert Bloom; 2) **Crazy Diamond**, Liga & Soren Hoy; 3) **Petard**, Farr 36, Keith Buck/Andy Newell, 4) **Mintaka 4**, Farr 38, Gerry Brown; 5) **Max**, Antrim 27, Ryan Richard. (13 boats)

PC J (96-117) — 1) **Balineau**, Olson 25, Charles Brochard; 2) **For Pete's Sake**, Ultimate 24, Peter Cook; 3) **Two Scoops**, Express 34, Chris Longaker. (9 boats)

PC K (120-159) — 1) **Life is Good**, WylieCat 30, Andy Hall; 2) **1st Impression**, SC 27, Rick Gio/Jan Grant; 3) **Crew's Nest**, Catalina 34, Ray Irvine. (7 boats)

PC M (162-195) — 1) **Eclipse**, Hawkfarm, Fred Hoffman; 2) **Thanks Mom**, Cal 9.2, Mike Wommack; 3) **Wuvulu**, Islander Bahama 30, John New. (3 boats)

PC D (SF 30) — 1) **Shameless**, Schumacher 30, George Ellison; 2) **Elusive**, Olson 911S, Charles Pick; 3) **Plan B**, J/29, Brett DeWire/Rob Stubblefield. (4 boats)

PC (SF 180) — 1) **Windsome Wench**, Newport 30, Robbie Murphree; 2) **Starkite**, Catalina 30, Laurie Miller; 3) **Huge**, Catalina 30, Russell Houlston/William Woodruff. (3 boats)

#### CROWN JEWEL TWILIGHTS (IYC, 5r/1t)

DIVISION A (PHRF <150) — 1) **Spirit Of**, Bill Mohr, 7 points; 2) **Crazy Eights**, Aaron Lee, 10; 3) **Ad Lib**, Neil Dodds, 11. (9 boats)

DIVISION B (168 Raters) — 1) **Phantom**, John Guilliford, 5 points; 2) **Bewitched**, Laraine Salmon, 8; 3) **Dire Straits**, Dawn Chesney, 10. (3 boats)

DIVISION C (>150) — 1) **Nightengale**, 'Ned', 5 points; 2) **My Tahoe Too!**, Steve Douglass, 6; 3) **Wuvulu**, John New, 11. (6 boats)

NON-SPINNAKER — 1) **Galatea**, Ken Viaggi, 4 points; 2) **Cat Nip**, Bruce Hasson, 7; 3) **All Funk'd Up**, Susan Ingram, 15. (3 boats)

SANTANA 22 — 1) **Meliki**, Tom Montoya, 4 points; 2) **Atuna Matata**, Bill King, 9; 3) **Fun Zone**, Tom McIntyre, 11. (5 boats)

Complete results: [www.iyc.org](http://www.iyc.org)

NOTE: Above are cumulative scores for the Spring Series, which ended 6/27. The Summer Series began 7/25 and runs through 9/26.

#### FRIDAY NIGHT SERIES (TYC, 8/8\*\*)

DIVISION A/B — 1) **Joyride**, J/105, Bill Hoehler; 2) **Frenzy**, Moore 24, Lon Woodrum. (6 boats)

DIVISION C — 1) **Galante**, Folkboat, Otto Schreier; 2) **Siento el Viento**, C&C 29, Ian Matthew; 3) **Wind Dance**, Cal 2-27, Ann Watson. (4 boats)

Complete results: [www.tyc.org](http://www.tyc.org)

# THE RACING

Complete results (including Sunday): [www.yra.org](http://www.yra.org)

## Snipe Nationals

Veteran Snipe sailor Augie Diaz and crew Kathleen Tocke bested a relatively small, but high-quality fleet by six points at the 2008 Snipe Nationals hosted by Richmond YC, August 4-8. The duo counted five bullets and a second after throwing out a third, to beat Ernesto Rodriguez and Leandro Spina. Another six points back, Peter Commette and David Harrison rounded out the top three.

The 31-boat fleet had some real gear-busting conditions, and we understand there were more than a couple bent rigs and other carnage. But it wasn't enough to bother Nick Voss and Tom Fink.

The duo followed up their win in the five-boat Junior Nationals — held the weekend preceding the main event — by finishing fourth overall against some of the class' big names. Carolina Palacios and Rogelio Padron won the two-boat 'Special Junior' Nationals, for the youngest of the bunch.

2008 SNIPE NATIONALS (RYC, 8/2-8, 5r/1t)



**'White Fang' led the pack in PC G on Sunday at the YRA 2nd-Half Opener July 26-27.**

1) Augie Diaz/Kathleen Tocke, 5.75 points; 2) Ernesto Rodriguez/Leandro Spina, 10.75; 3) Peter Commette/David Harrison, 16.75. (31 boats) results at: [www.snipenationals2008.com](http://www.snipenationals2008.com)

## 505 PCCs

Mike Martin and Jeff Nelson dominated a star-studded field of 24 boats at the August 9-10 505 PCCs, hosted by St. Francis YC. Whether sailing on the Circle Saturday, or Cityfront on Sunday in breeze to the mid-20s, the duo won races — a lot of races.

Actually they won every race, reprising their win at the St. Francis YC's Spring Dinghy regatta earlier this year — having to drop a bullet as their throwout. Martin's former skipper Howie Hamlin, with whom he won a Worlds in the class, sailed with Andy Zinn to second place, finishing seven points back in the six-race, one-throwout series.

How'd they do it?

"People always ask me that," Martin said. "I don't really know other than we have very good upwind boatspeed which means we can extend upwind and sail conservatively. Downwind we're on par with everyone else."

Third up were Nor Cal sailors and former Olympians, San Carlos' Nick

**COMING SOON - FT 7.5M**

[www.flyingtigerboats.com](http://www.flyingtigerboats.com)

**FAST, FUN, AFFORDABLE**



Adamson and Santa Cruz' Steve Bourdow. Two other class enthusiasts better known for their big boat — read: really big boat — exploits, Hasso 'Morning Glory' Plattner and Philippe 'Pegasus' Kahn also showed up, with Plattner prevailing in the clash of the software titans.

Next up for Martin and Nelson is the October 6-17 Worlds in Palermo, where they'll be using their standard setup: off-the-shelf Glaser sails and a Super Spar M2 mast.

Next year they'll be working on some sails designed specifically for the Bay, as the 2009 Worlds will be hosted by St. Francis YC. If their results here this year are any indication, they'll be the ones to beat come next August. And probably this October also.

505 PACIFIC COAST CHAMPIONSHIP  
(StFYC, 8/9-10, 6r/1t)

1) Mike Martin/Jeff Nelson, 5 points; 2) Howie Hamlin/Andy Zinn, 12; 3) Nick Adamson/Steve Bourdow, 17; 4) Dalton Bergan/Fritz Lanzinger, 20; 5) Mike Holt/Neil Fulcher, 24. (25 boats)

complete results at: [www.stfyc.org](http://www.stfyc.org)

### Olympic Regatta

Anna Tunnicliffe hit a home run on the penultimate leg of the women's singlehanded medal race in the Laser Radial at the Qingdao Olympics, picking a massive left shift that sent her from zero to hero.

Leading the regatta going into the race, Tunnicliffe tried a risky start — at 30 seconds to go, she jibed away from a safe leeward position a little over halfway down the line from the committee boat.

Looking like she was going to be late, Tunnicliffe snuck in to weather of Kiwi Jo Aleh, who was over the line. When the individual recall flag went up, Tunnicliffe thought she may have been as well, and restarted. This left her third to



FRIED ELLIOT/WWW.FRIEDBITS.COM

**Augie Diaz and Kathleen Tocke dominated the 2008 Snipe Nationals at Richmond YC.**

last around the weather mark, seemingly out of contention for a medal.

After losing another boat on the run, she banged that corner until she was reaching into the weather mark on port tack, having passed five boats in the process, back in position for a gold.

On the final run, she passed another boat to take second in the race, the sec-



## LOCATION, LOCATION, LOCATION!

Close to South Beach Marina & Giants Park  
Next to the historic Ramp Restaurant

## SAN FRANCISCO BOAT WORKS

835 Terry A. François St., San Francisco, CA 94158  
(415) 626-3275 Fax (415) 626-9172

[www.sfboatworks.com](http://www.sfboatworks.com) [sfboatworks@yahoo.com](mailto:sfboatworks@yahoo.com)

Be our guest for lunch at the historic Ramp Restaurant\*

\*Some restrictions apply



## DISCOUNTS EXTENDED!

*Including:*

**50% OFF** Haul & Launch  
**25% OFF** Bottom Paint  
**10% OFF** Yanmar Parts  
**20% OFF** Selected Parts

## NEW!

Order parts online!  
Call us on weekends!  
Request a quote online!



# THE RACING

and U.S. medal in sailing at the 2008 games, and the only gold.

American Finn sailor and St. Francis YC member Zach Railey sailed way above most people's expectations, sailing a consistent series and winning a silver medal in a competitive class. Going into the medal race, Railey was not assured of a medal.

Before Friday's attempt at a race in the light and fluky Fushan Bay was abandoned due to no wind, it didn't look like he would, with GBR's now triple-gold medallist Ben Ainslie keeping a tight lid on the upstart.

But Railey made good use of his second chance the following day, recovering from a bad start to steadily work himself back into position, scoring a fifth in the 20-plus knots of breeze and washing-machine sea state.

Except Tunncliffe's gold and Railey's well-earned silver, the Alphagraphics U.S. Sailing Team did not have a good regatta overall — and that's an understatement. The only other event where American sailors had a decent regatta, was in the 49er, where Tim Wadlow and



LUC DEFAYMOREAU

*The annual Running of the Bulls in Moss Landing last month featured the debut of the new schooner-rigged 'Maltese Toro'... Okay, it's just eventual 'Senior A' winner Art Lange chasing John Pacholski. Results in Box Scores.*

Chris Rast sailed pretty well — reeling off three straight bullets at one point.

They were contenders going into the

medal race until gear failure followed a great start, causing them to miss the finish deadline.

We actually enjoyed watching that much-ballyhooed race — seeing every top-ranked team flip gave a great indication of how gnarly the sea state was, and the actual challenge of sailing the boats is what the Games should be about.

John Dane and Austin Sperry's 'no-check-goes-unwritten' Star campaign failed to qualify for the medal race when their extremely light-air-gear set-up was greeted with decidedly un-Qingdao conditions — breeze in the 20s and sloppy seas on days two and three. The pair didn't qualify for their medal race, ending up in eleventh.

John Lovell and Charlie Ogletree's code zero designed and built for the venue's prevailing breeze turned out to be a non-starter for the same reason. Inexplicably, they used both their measurement tags on those little-tested sails instead of measuring a conventional kite as well.

In the men's boardsailing, Ben Barger

## SCHOONMAKER POINT MARINA

• IN SAUSALITO •



Call the Marina Office  
for more information

**415•331•5550**

**FAX 415•331•8523**

or check our web site at  
[www.schoonmakermarina.com](http://www.schoonmakermarina.com)

85 LIBERTY SHIP WAY, #205  
SAUSALITO, CA 94965



**160 Berth Marina in one of the most  
beautiful spots on the Bay**

- Visitor berths • Guest moorage able to handle yachts up to 200 ft.
- Dry storage • Waterfront Offices • Three-ton Hoist • Windsurfing
- Deli • Beach • Rowing • Kayaking • Yacht clubs always welcome



managed a bottom-third finish, also not qualifying for the medal race. Same story in the women's, where Nancy Rios was next to last.

Neither U.S. 470 team managed to qualify for their medal race, despite some promising results in international competition leading up to the event.

The Yngling team of Sally Barkow, Debbie Capozzi and Carrie Howe finished seventh, after an inconsistent regatta which nonetheless put them in the bronze position going into their disappointing medal race.

Andrew Campbell failed to qualify for the men's singlehanded medal race in the Laser, finishing 25th of 43 after a black-flag penalty and DSQ.

Well, there's always Weymouth in 2012. . . .

#### Race Note

*Attack of the Moths* — Detroit's Bora Gulari won the International Moth U.S. Championship August 15-17 at Cascade Locks, Oregon.

Gulari was among the first Ameri-

cans to pick up one of these 10-ft boats that fits in a box, weighs only 65-pounds all-up and will do speeds in the mid-20s.

His time in the boat showed when he won all nine races.

The Columbia Gorge Racing Association, known for everything from its community sailing programs to its renowned race management, has become a favorite with dinghy and small keelboat sailors.

It played host for the event, which attracted some 'mothies' you may have heard of but didn't know were into flying including Santa Cruz' Morgan Larson.

We haven't come across any on the



SEAN TREW/WWW.PACIFICFOG.NET

*Lift Off* — George Peet foiling around a leeward mark at the 2008 Moth NAs at the Gorge, hosted by the Columbia Gorge Racing Association.

Bay yet — maybe hanging a light on the Golden Gate Bridge might attract some — but we heard a rumour that Express 27, El Toro and Pacific Cup sailor Buzz Blackett is waiting on delivery of one to give foiling a try — nice!



## WELCOME TO THE NEW HANSEN RIGGING

### 100% RIGGING FOCUSED

- New, convenient location
- New retail rigging store
- New inventory

## HANSEN RIGGING

2307 Blanding Ave.  
Alameda

(510) 521-7027

[hansenrig@sbcglobal.net](mailto:hansenrig@sbcglobal.net)

WINNER



Only the best! Exclusive rope straight from '08 TP52 Med World Series on sale NOW!

**Congratulations to  
Pacific Cup winner Raindrop  
First to Finish • First Overall**

[www.hansenrigging.com](http://www.hansenrigging.com)

# WORLD

We depart from our usual format this month to bring you a special report this on **The Sun-Kissed Isles of the Eastern Caribbean.**

## Caribbean Dreamin': 500 Miles of Spectacular Sailing

We consider ourselves extremely fortunate to have spent many happy days sailing the waters of the Eastern Caribbean. Although we've visited many parts of the 500-mile island chain which lies between Puerto Rico and Grenada, there are still places we've yet to explore. And we can honestly say that we never tire of even the most familiar island groups, such as the British Virgins.

The moment we step out of a plane onto the tarmac at Tortola, Antigua or St. Martin we always break into a broad smile, because the instant those warm easterly trade winds wash over us, the stress of modern urban living just seems to melt away. With the promise of sunny skies, clear, warm water and average daily temperatures in the low 80s throughout the year, it's no wonder that the emerald isles of the Eastern Caribbean — the Lesser Antilles, in geographer's terms — comprise the most popular yacht chartering region in the world.

But it's not just the steady breeze and ideal climate that draw sailors here from every continent. Due to the fact that Spain, England, France, Holland and Denmark all vied for control of these sugar-rich islands during the tumultuous colonial era, today each island, or cluster of islands, has its own unique cultural heritage. You'll find that doing

**Ahh, St. Barth. This tiny gem has long been a must-see stopover when cruising the Northern Leewards.**

a bit of homework on the region's history before you set sail will add immeasurably to the enjoyment of your cruise.

Another important pre-travel tip is to work at being a 'beautiful American', as opposed to an 'ugly American'. After enduring decades of seemingly wealthy and carefree tourists, some West Indians are a tad sensitive. So barging into a shop or restaurant with a 'New York attitude' and demanding, "I need a \_\_\_ (whatever) right away," will typically get you the slowest service you've ever seen — if you get any service at all. By contrast, walking in with a big smile and a sincere greeting — "Good morning. How are you today?" — will typically yield a helpful, friendly response. It's all about mutual respect. Given the region's legacy of slavery, many West Indians are still a bit prickly about the servile roles in which many are employed. With that simple caveat understood, you'll find that most West Indians are warm, wonderful folks who will often go out of their way to make you feel welcome in their island realm.

If we had nothing but time and money, we'd pursue one of our favorite fantasies: exploring the entire Lesser Antilles chain under sail. Along the way, we'd snorkel the myriad reefs, hike up goat trails to take in panoramic views and hang out with the locals in every thatch-roofed beach bar along our route. Realistically, though, it would take months just to take a cursory look at it all, and years before we could say we really knew the entire region well. So that sort of exploring will have to wait until we hang up our editing

spurs and go cruising.

By the same token, the first thing potential charterers must decide is which section of the chain to sail in. To help you with that difficult task, we'll take a once-over-lightly look at the options.

*The Virgin Islands* — Any one who's ever picked up a sailing rag is probably aware that the U.S. and British Virgin Islands make up one of the most cherished cruising grounds on earth — with the British section of the archipelago getting the lion's share of the chartering business.

With more than a dozen islands closely clustered together, sailing distances are short and the entire region is relatively well protected from ocean swells. Add to this the fact that the BVI government has taken a conservative stance on both development and environmental protection. Years ago, this entire British Trust Territory was wisely designated as a marine park in order to preserve its delicate underwater ecosystem. And shoreside development has been kept in check also. There's not a single high-rise hotel in the BVI, yet there's ample yachting infrastructure to service the large fleets of charter and recreational boats that are based here. There are also plenty of waterside resorts where sailors are welcome, plus boutiques, fine restaurants and 'watering holes'.

The must-sees here are familiar names to most globe-trotting sailors: Virgin Gorda's Bitter End Yacht Club and the famous snorkeling spot called The Baths; Foxy's Tamarind Bar on Jost Van Dyke; crescent-shaped Cane Garden Bay on Tortola; and the Norman Island treasure caves.

The U.S. Virgin Island of St. John lies a short sail across the narrow Sir Francis Drake channel from Tortola — the BVI's principal island. Although a visit to St. John or its sister islands, St. Thomas and St. Croix, requires clearing out and back in again, doing so is a worthwhile idea, especially for repeat visitors. More



AARON TURPIN



LATITUDE / ANDY



# OF CHARTERING



seem to give us a window on the 'old Caribbean' so often depicted in classic works of literature.

Taken as a whole, a loop from St. Martin to St. Barth, Nevis, St. Kitts and perhaps Saba and Anguilla create a nice balance, both culturally and in terms of shore-side attractions.

For us, some of the highlights here are going clubbing on St. Maarten; hanging out on St. Barth's gorgeous (topless) beaches and chillin' at the world-famous Le Select bar in downtown Gustavia; hiking the nature trail on Nevis while trying to spot elusive green monkeys and visiting the island's restored plantation-hotels; looking out across the Leewards from the massive stone battlements of Fort Brimstone, dubbed the Gibraltar of the West Indies during the 1700s; and diving the amazing dropoffs of Saba. All in all, such a cruise is a delightful balance between the luxuri-

ous and the laid-back, the sleepy and the super-charged, where you'll anchor stern-to a busy cay one night and alone

***At Pinney's beach on Nevis you'll find a funky palm-roofed beach bar called Sunshine's where you're guaranteed to have a good time.***

***Squint your eyes and you'll see that these lovely ladies are spelling out "B-V-I." Whether we're sailing alone or with a bevy of college coeds, we never tire of cruising the familiar waters of the Eastern Caribbean.***

than two thirds of St. John is a minimally developed national park which, travel writers agree, contains some of the most spectacular beaches in the entire Caribbean. (Note also that several charter fleets are based in the U.S. Virgins, whose boats may be taken into BVI waters.)

**The Northern Leewards** — Roughly 90 miles south of the BVI's Virgin Gorda lie the northernmost isles of the Leeward Antilles. Here, the French/Dutch island of St. Martin/St. Maarten is home to large charter bases, making it an ideal jumping off point for a loop tour that includes French, Dutch and formerly British islands.

We should clarify here that, like other French Caribbean islands, both St. Martin and St. Barth are still very much a part of Mother France. Their citizens carry French passports, and a trip from a French Caribbean island to Paris is a

'domestic' flight. Similarly, the Dutch half of Sint Maarten, as well as nearby Saba and St. Eustatius (Statia), is still affiliated with The Netherlands. However, most of the formerly British islands of the Caribbean are now independent nations.

This distinction manifests itself in substantially different levels of development and government infrastructure throughout the Antilles. St. Martin/St. Maarten, for example, has loads of swank hotels, modern supermarkets, casinos, fine restaurants and tourist-oriented shops offering fine jewelry and electronics. By comparison, walking the downtown streets of nearby St. Kitts and Nevis — formerly British islands which, together, now form one nation — you'll feel as though you've stepped back in time. Shopping opportunities are extremely limited and the pace of living is slow, slow, slow.

We like it that way, of course, as these lush, volcano-formed isles



LATITUDE / ANDY



# WORLD

in a serene anchorage the next.

*Antigua & Barbuda* — Thanks to the enduring fame of Antigua Sailing Week, every sailor on the planet has heard of Antigua. As you may know, this now-massive week-long regatta — the largest in the Caribbean basin — began as an end-of-season celebration where the local charter fleet blew off steam through a series of races. Then, as now, Antigua was the winter base for some of the world's most spectacular yachts. They converge annually on the neighboring bays of Falmouth and English Harbor, creating an eye-popping collection of nautical artistry. This fact alone is reason enough to visit Antigua — but it's certainly not the only reason.

Anytime other than the peak winter season, you'll probably be allowed to stern-tie your bareboat to the historic seawall of Nelson's Dockyard in the heart of English Harbor. Built by the British in the early 1700s as an easily defensible base for its British West Indies Squadron, the Dockyard's stone warehouses, workshops and officer's quarters have now been thoroughly renovated, serving as shops, restaurants and hotels.



ALL PHOTOS LATITUDE / ANDY

**Although the smaller islands of the Antilles can be dry and scrubby, big islands like Guadeloupe have lush rain forests fed by natural springs.**

We think you'll agree that it's one of the coolest nautical centers on the planet.

Whether you begin a bareboat cruise (or crewed charter) at Antigua or arrive there from another island, we suggest you consider doing a complete circum-

navigation of the island, as the coast is peppered with beautiful sandy beaches and plenty of protected anchorages. Some are adjacent to waterside resorts, while others, tucked within the maze of reefs on the island's north and east coasts, offer total seclusion.

As with most islands of the Antilles, it's well worth renting a car and touring the relatively sleepy interior of the island. Exploring the narrow streets of Antigua's port and capital city, St. Johns, you'd never know the other end of the island was a mecca for millionaires and megayachts.

After the Brits loosened their grip on their Caribbean possessions, Antigua teamed up with nearby Barbuda to form a two-island nation. But the sister islands have more differences than similarities. Lying 28 to the north, and fringed by bountiful reefs, Barbuda sees only a minute amount of tourism compared to Antigua, and its only real industry is fishing. Its one and only town is about as laid-back and minimally developed as any we've seen in those latitudes, but to us that's a big part of



Tortola BVI  
Belize  
The Grenadines

UNIQUELY  
**TMM**



Marisa  
TMM Belize

Most charter companies offer blue water & palm trees, but it takes the personalized care of people like Marisa to make your vacation a success.

Like Marisa, everyone at TMM is committed to your complete satisfaction. Our specialized three-location operation offers large company quality with small company service. A combination that is uniquely TMM.



**TMM**  
Yacht Charters  
Since 1979

catamarans • monohulls  
motor yachts  
ownership programs

**Real People. Real Sailing. Real Fun.**



Sail Cats | Power Cats  
Monohulls | Trawlers  
Bareboat | Skipped

**Real Choices.**

Choose CYOA and become part of the family. We've been providing beautifully maintained yachts, personal service and sensible prices to sailors since 1980.

1-800-944-2962  
info@cyoacharters.com  
www.cyoacharters.com  
St. Thomas USVI 00802





**CYOA**  
YACHT CHARTERS



# OF CHARTERING

its appeal — not to mention the fact that Barbuda's snorkeling and diving are superior to more popular islands.

Naturally, you have to arrive with good overhead light to avoid unintended encounters with offshore coral heads, but we wouldn't call the navigation there particularly difficult. The favorite anchorage, off Coco Point Beach is spectacularly beautiful and the underwater visibility is excellent.

Ashore, on this flat, coral-formed island, you'll find a bare minimum of development and a small population of friendly islanders, most of whom will be happy for a little interaction with outsiders. When we checked in, we were told by the jovial police chief — who must have stood 6'5" — that during the plantation era, the biggest and strongest Africans were sent to Barbuda to breed ideal workers for the English plantations.

*Guadeloupe, Dominica & Martinique* — Forty miles south of Antigua lies the large, butterfly-shaped island of Guadeloupe. Mountainous and lush, it boasts numerous rivers, waterfalls and hiking trails that are well worth checking out.

Charter bases are located in the capital city, Point A Pitre, where you'll find well-stocked markets that are chock full of French products, and a variety of good restaurants serving rich French-creole cuisine. We think the best thing about Guadeloupe, though, is its near-shore diving preserve at Isle Pigeon, which was established by the Cousteau Society. Situated in the lee of the island, it promises some of the best diving in the Southern Caribbean.

Another nearby destination which should be high on your must-see list is a little cluster of nearby islands called Les Iles de Saintes. The population here is still very much focused on the sea, with many of the men still making their living by fishing. Day trippers from Guadeloupe

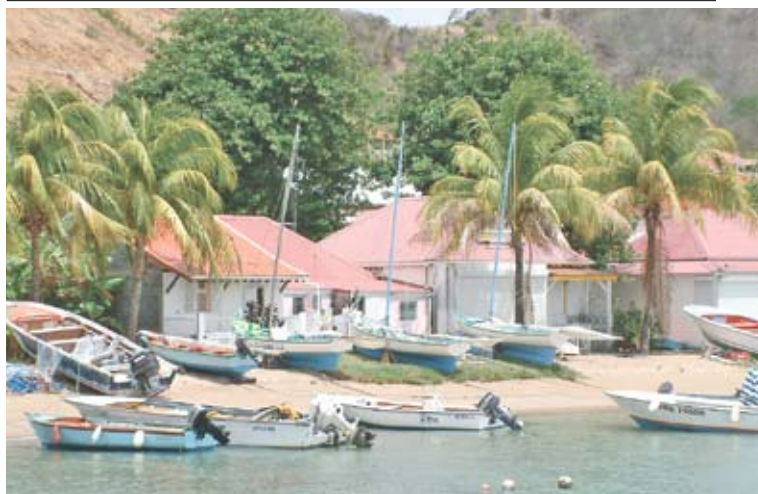

*Not far from Guadeloupe lies Les Saintes, a cluster of tiny French islands whose culture revolves around fishing and sailing.*

descend on the main island, Terre den Haut, during the middle of the day, but by late afternoon they've all disappeared and the mood of the island is decidedly mellow. Beachfront restaurants with views of the harbor are perfect for sun-down aperitifs and fine French cuisine.

One of the truly bizarre twists of Caribbean history is the fact that between

NORTH AMERICA | CARIBBEAN | MEDITERRANEAN | SOUTH PACIFIC | INDIAN OCEAN

BAREBOAT | CREWED | SKIPPED

WHERE QUALITY OF SERVICE,  
MEETS QUALITY OF LIFE.

Our 38-year reputation for integrity, quality and reliability has satisfied the most discriminating sailors. Trust The Moorings. We promise our quality of service will enhance your quality of life.

Visit the most trusted name in chartering  
[www.moorings.com](http://www.moorings.com)  
800-521-1198

  
The Best Sailing Vacations In The World!

# WORLD

French Guadeloupe and its southern sister, Martinique, lies the formerly British island of Dominica. Today, while the French islands thrive due to support from Paris, Dominica remains one of the poorer and least-developed islands in the Caribbean. Until recent years, it saw very little tourism apart from a few adventurous sailors. Here again, to our way of thinking that's an excellent reason to pay a visit. Many Caribbean cruisers report that Dominicans are generally some of the friendliest islanders you'll encounter, perhaps because foreigners still arrive in relatively small numbers. Two must-do activities here are taking a hike through the virgin rain forest of the national park — there are many well-maintained trails — and taking a boat ride with a local guide up the jungle-like Indian River.

Just south of Dominica, the French island of Martinique is the first isle of the Windwards. Functionally, it also serves as a dividing line for charterers, in that most who charter out of Guadeloupe head north, while those who charter out of Martinique typically head south.



**Sailing 'up-island' from Antigua you'll pass a curious rocky pinnacle that's officially called the Kingdom of Redonda.**

Wandering around the island's capital, Fort de France, the atmosphere may remind you of the South of France. You'll find yourself bumping into chic sophisticates who've newly arrived from Paris, as well as laid-back islanders who make their living on the sea.

Over the years, we've observed a cu-

rious thing about Caribbean islanders: Those from English-speaking islands rarely, if ever, visit the French Islands, and the opposite is also true. We've made several one-directional trips from Guadeloupe north to the BVI, and through conversations with islanders we met along the way, we found that during our 10-day tour, we would see more of the island chain than many life-long residents do. You will have to pay a re-delivery fee to do a one-directional trip like that, but we think you'll regard it as money well spent when you realize how much more you can see that way. And if you go south to north, you can generally eliminate most windward sailing — which becomes particularly appealing if you've rented a cat.

*The Grenadines & Grenada* — Although the large, verdant isle of St. Lucia is an independent nation, we include it here because it most often serves as a jumping off point for Grenadine charters out of The Moorings' charter base at idyllic Marigot Bay.

In the past couple of decades, a dra-

**GET READY for the CARIBBEAN!**

1. Pack for the sun.
2. Go to the airport.
3. Meet our friendly staff.
4. Sail away for the day or month.
5. Sunbathe. Snorkel. Wine. Dine.

**YACHTS from 31-52 feet**  
Crewed yacht charters available  
10% off to repeat customers  
Monthly specials

**B.V.I. YACHT CHARTERS**  
www.bviyachtcharters.com

Joma Marina, Port Purcell, Tortola  
284-494-4289 or 888-615-4006  
fax 284-494-6552  
charters@bviyc.com

**BRITISH VIRGIN ISLANDS**  
**"BEST DEALS ON KEELS"**

- Most selection of sailboats 32'-52'
- "Purr" with cats 38'-47'
- Bare boat or skippered
- Best yacht management program

**Conch Charters**  
Est. 1986

**NEW YACHTS IN FLEET!**

**www.conchcharters.com**  
Email: [sailing@conchcharters.com](mailto:sailing@conchcharters.com)  
Call our 'Sails' Office  
(USA) (800) 521-8939  
Tel (284) 494-4868 • Fax (284) 494-5793

*Sail paradise with Conch Charters*

**CALIFORNIA'S CARIBBEAN CONNECTION**



# OF CHARTERING

matic increase in yachting infrastructure has helped attract more and more cruising sailors to St. Lucia. And since 1990, it's been the western terminus of the transatlantic ARC rally (Atlantic Rally for Cruisers), which gives the local economy a tremendous boost every year.

Like Guadeloupe, Dominica and Martinique to the north, and St. Vincent — the largest island of the Grenadines — to the south, St. Lucia is lush and mountainous. If you've only been to the Virgins, which are too dry to support much agriculture these days, you'll be shocked at how fertile these large central islands are, and how much agriculture they support. It's well worth hiring a taxi or renting a car for an afternoon to visit their lush mountainous interiors.

St. Vincent, which has been home to small charter bases for decades, has a number of worthwhile attractions, not the least of which is its botanical gardens where you can see a massive breadfruit tree brought there by the infamous Captain Bligh — honest. But most vacationers immediately set sail for the charming

ALL PHOTOS LATITUDE / ANDY



little island of Bequia, about 10 miles to the south.

Bequia has long been a favorite getaway destination for Caribbean sailors and foreigners alike. It isn't quite as low-key today as it once was, but compared to most places on Planet Earth, it's still pretty darned mellow. Restaurants, bars and shops line the beach behind the principal anchorage, Admiralty Bay, where you'll meet islanders who take great pride in their heritage as boatbuilders, fishermen and whalers. Bequia is

**St. Martin's Orient Bay is alive with action: beach bars, restaurants, parasailing, kiteboarding, windsurfing — even a nudist resort.**

one of those cozy, feel-good places that you will not be anxious to leave.

But the rest of this well-protected cluster of tiny islands is also well worth exploring. As in the Virgins, the passages between islands are short, and tranquil anchorages are many. Funky beach bars and mini-resorts are peppered throughout the group, with the cluster called the Tobago Cays being the favorite spot for

## Great Sailing Vacations for Incredible Value!

Price Guarantee  
BEAT ANY OFFER  
BY \$100!  
Call for Details

Save 10%  
with Footloose!  
Call for Details  
or visit us online  
[www.footloosecharters.com](http://www.footloosecharters.com)



[www.FootlooseCharters.com](http://www.FootlooseCharters.com)  
888-852-4666



# WORLD OF CHARTERING



LATITUDE / ANDY

snorkeling. The anomaly here is the little island of Mystique, where a number of world-class celebrities maintain island hideaways.

The division between The Grenadines and their southern neighbor, Grenada, is a bit confusing to some first-timers, as the huge, mountainous island of Grenada possesses several small islands that are geographically part of the Grenadine cluster. The largest of these is Carriacou, where we're told some of the last old-style Caribbean boatbuilders still practice their craft near the water's edge.

*Imagine a place where you can swim as the sun sets and not even get a chill. Seen here are honeymooners at Virgin Gorda's famous Baths.*

If you had at least 10 days, a dream trip for any sailor would be a one-directional cruise from Grenada to St. Vincent or St. Lucia — or vice versa depending on the season and its corresponding NE or SE wind angle. Booming open-water passages between the big islands, would be balanced by peaceful cruising through the near-flat waters of the Grenadines. Compared to the Virgin Islands, the number of boats found in these southern

regions is dramatically fewer. If budget concerns are steering you toward sailing in the 'low seasons' — summer and fall — choosing these southern stretches has the added appeal that hurricanes rarely make landfall in these latitudes.

We should mention also that Grenada itself is a wonderful place, worthy of spending a couple of extra days before or after your charter. In addition to having many beautiful beaches, Grenada has a lush, mountainous interior with several dramatic waterfalls and refreshing swimming holes. Dubbed 'the spice island' long ago for its plantations of nutmeg trees, the island's agrarian economy remains strong today. And the classic colonial-era harbor at St. Georges, lined with vintage red-roofed buildings, remains one of the most picturesque ports in the entire Antilles chain.

As you now see, the sailing possibilities in the islands of the Eastern Caribbean are seemingly limitless — which is all the more reason to get started soon!

— latitude/andy



## YACHT CHARTERS IN GREECE, TURKEY AND CARIBBEAN

**Best Rates For Reliable Charters**  
Full services: Low fares, hotels, tours, transfers

Visit our website for yacht photos and details, destinations and itineraries:  
[www.albatrosscharters.com](http://www.albatrosscharters.com)

**SAIL AND SCUBA DIVING IN GREECE**

Sailboats • 30'-60'  
Bareboat/Crewed  
Monohulls & Catamarans  
Luxury Sail & Motor  
5 to 60 Guests

**Albatross**  
An American owned and operated company

(800) 377-8877  
(856) 778-5656  
Box 250, Moorestown, NJ 08057

## ANACORTES YACHT CHARTERS

PACIFIC NORTHWEST ADVENTURES

Largest Selection of Charter Yachts in the Pacific Northwest

Bareboat & Skipped

Power and Sail 28'-66'

Charter Yacht Ownership

Yachting & ASA Sailing Schools

*Enjoy Yachting for a Lifetime with the World's Best!*  
Rated #1 by Cruising World



*Sizzlin' Summer Savings up to 15%*

[www.ayc.com](http://www.ayc.com) 800.233.3004



## DESOLATION SOUND YACHT CHARTERS LTD

Comox, B.C.

**Closest full-service charter base to Desolation Sound & Princess Louisa Inlet**

Visit our Web site for a preview of our 25' to 54' Power & Sail fleet

**BOOK YOUR CRUISING ADVENTURE NOW**  
Check out our New Lower Rates!

e-mail [charter@desolationsoundyachtcharters.com](mailto:charter@desolationsoundyachtcharters.com)  
<http://www.desolationsoundyachtcharters.com>

#101-1819 Beaufort Ave., Comox, BC, Canada V9M 1R9  
TOLL FREE 1-877-647-3815 FAX (250) 339-2217



Norman Diego's  
**THE MEXICAN INN**  
CABO SAN LUCAS

Abasolo y 16th Septiembre  
Next to the Port Captain's Office

**\$65 + TAX INCLUDES BREAKFAST!**  
**SPECIAL RATES FOR BAJA HA-HA**

[www.themexicaninn.com](http://www.themexicaninn.com)  
U.S.: (866) 434-3467 • Cabo: (624) 143-4987



**SAUSALITO**

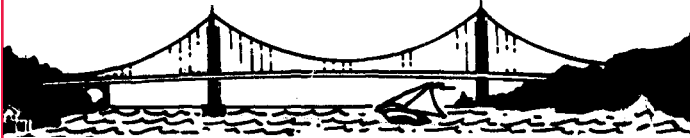

**LIST MARINE INC.**

- Full service engine shop
- We service all makes
- Dockside facilities
- Mobile service trucks



P.O. BOX 2008 / 69 LIBERTY SHIP WAY • SAUSALITO, CA 94966  
Adjacent to Schoonmaker Pt. Marina

**415•332•5478**

**www.listmarine.com**

**HAVE WE GOT A CAT FOR YOU...**

**GO CATS**  
Catamaran Charters Worldwide

*In North America*  
**Call for a Brochure**  
**1.800.592.1254**  
**WWW.GOCATS1.COM**

**SOUTH PACIFIC • MEDITERRANEAN • CARIBBEAN • INDIAN OCEAN**

**CHARTERS: BC Canada • Mexico • Offshore**

Trips available for groups, individuals or couples

57-ft Luxury Sailing Vessel **WESTERN GRACE**

- |                                       |                         |                       |
|---------------------------------------|-------------------------|-----------------------|
| • Private Charters BC Canada & Mexico |                         | \$5,000-\$11,000/week |
| • Cabo San Lucas to La Paz            | Nov. 10-17              | \$900/p.p.            |
| • La Paz to Puerto Vallarta           | Nov. 30 – Dec. 10       | \$1,400/p.p.          |
| • Puerto Vallarta to Hilo, HI         | Mar. 29 – Apr. 23, 2009 | \$2,680/p.p.          |
| • Hilo, HI, to Victoria, BC           | Apr. 29 – May 22        | \$2,680/p.p.          |

**www.WesternGrace.ca**

**808.271.3540**

sailaway@westerngrace.ca



**GLEN COVE MARINA**

*A secret destination for your cruise this summer!*

*Located on the Carquinez Straits*

- |                                    |                     |
|------------------------------------|---------------------|
| • Covered Slips Available          | • Waterfront Cafe   |
| • Home of the Glen Cove Yacht Club | • Showers & Laundry |
| • 135' Guest Dock                  | • Free Pump Out     |
| • Free Wireless Internet           | • On-Site Security  |
|                                    | • Yacht Broker      |

*Now Available:*

**24 ft - 32 ft - 36 ft - 44 ft Covered Berths**

**Up to 55 ft Uncovered Berths**

*Two 55' Slips Available Now*

*New Waterfront Cafe*



**GLEN COVE MARINA 707-552-3236**

2000 Glen Cove Road, Vallejo, CA 94591

**www.glencovemarina.net • glencovemarina@gmail.com**



**Mission Creek Sail Tours, LLC**



'Imi Loa  
San Francisco, CA

**Sailing San Francisco Bay Since 1996**

San Francisco, "The City by the Bay", is one of the most exciting destinations in the world and the most memorable way to experience it is from the water aboard your private sailing yacht.

**Romantic Sunset Sails • Private Bay Tours  
Wine Tasting Cruises • Corporate Team Building**

Conveniently located at South Beach Harbor  
(between AT&T Park and Pier 40)

408-910-0095/408-377-2824

Charters@sfsailtours.com

http://www.sfsailtours.com

Call or email us for a *free brochure*

# CHANGES

With reports this month from **Destarte** ending a four-year sabbatical; from **Moonduster** in American Samoa; from **Caribbean Soul** in Grenada; from **Gallivanter** on sailing down the Caribbean chain; from **Raptor Dance** on what's newish in Mexico; from **Sailors' Run** on delightful San Lorenzo, Honduras; from **Tawodi** on a proposed seven-month circumnavigation; and **Cruise Notes**.

## **Destarte — Bristol Channel Cutter Jerry Murphy Four-Year Sabbatical Winding Down (San Diego)**

As I write this, my four-year sabbatical is almost over. For three years, I lived aboard my 28-ft *Destarte*, and we shared many experiences in the course of traveling more than 4,400 miles. Starting in Seattle, we visited the San Juans Islands and Canadian Gulf Islands, sailed down the West Coast of the United States, did the Baja peninsula, sailed up into the Sea of Cortez to Loreto and then over to Mazatlan on the Mexican mainland, then hit all the pretty harbors as far south as Manzanillo. It's been a great ride. I did over 1,700 of the miles singlehanded, but have also had some lively crew along the way, all of them good in their own ways.

What were the highlights? Sailing under the Golden Gate Bridge at 2 a.m., having just arrived from Eureka on my 49th birthday. Following in Steinbeck's *Log from the Sea of Cortez* footsteps, singlehanded among the islands. A month on the hook at unspoiled Bahia Tenacatita. Being loved by April and Matt; being taught by Eric and Robin; being befriended by Tex, Richard and Karen, Rosie and David, Roxanne and Jason, David and Kellie, John and Lela, and so many others. Sailing out of Bahia Santa Maria in a light fog. Anchoring at Reid Harbor in the San Juans. Tying up in front of the Empress Hotel in Victoria. Singlehanded in the moonlight

**Murphy found that while religion isn't as strong as it was in the States, it's still a big part of life in Mexico — right up to the cross.**

from Mazatlan to Isla Isabella. Being net controller on the Amigo Net on Saturday mornings. Getting Venus, the moon, and the sun to cross my position within a mile. Seeing Mercury with an unaided eye. Enjoying a lunar eclipse at Tena-catita Bay. Watching blue whales and humpbacks breaching. Seeing dolphins spinning off the coast of Washington. Enjoying rays doing triple back flips for the sheer joy of it. The dance of the blue boobies. Rewiring my boat — and having it work perfectly. Snorkeling alone in the Sea of Cortez. Solitary silence at Honeymoon Cove, Isla Danzante. Watching Mom steer *Destarte* through the bays of Orcas Island. Walking up the promenade to Mission San Javier in the mountains southwest of Loreto. The bonfire of fellowship at Muertos after the '06 Ha-Ha. My brother trusting me through two Pacific Northwest gales. A weekend with a Valencia family at their *casa de campo* in Jalisco. Sailing off the hook each morning in the Sea of Cortez. Hiking at Espiritu Santo. Feeling secure after heaving to in a gale off Oregon. Dinner at Maradaje and listening to Arena del Rio sing the songs of the 1850s–1940s. There's a story with each one of these memories, and if anyone pours me a glass of wine, I'll share them.

I want to thank everyone who made my adventure so meaningful and, to me, so successful. Thanks especially to my crews, and to Bob Stringari, who installed my engine and saved me oodles of money on gear. Thanks to Judy and Don Healy for putting me up on visits to San Diego. Thanks to my Mom whose prayers probably kept me safe. Thanks especially to my brother Dan for sailing with me on the hard parts.

Right now I'm sitting at my old table at the Sunset Bar in La Paz, drinking Carlita's special concoction, which is the best margarita on earth. I'm here to watch the sunset and pen this last letter from Mexico. The sunsets over the Sierra Gigantes and across Bahia de La Paz are uniquely spectacular. Tomorrow, I begin the 850-mile drive on the two-lane Transpeninsular Highway in my '96 Ford wag-



MOONDUSTER

on, the Prairie Schooner, up the Baja to San Diego. I hope the schooner makes it. Earlier today I drove past a billboard. There was an intelligent and beautiful woman featured on it. She was looking at me with a smile, asking, "*?Quieres trabajar?*" No, not really. But it's time.

I hope that my friends and I may meet again to share our stories of the joy of this wonderful life on this enchanting planet.

— jerry 07/22/08

## **Moonduster — S&S 47 Wayne Meretsky Bora Bora To Samoa (Alameda)**

As *Latitude* readers know from last month's issue, a number of cruisers had some problems when they got hit by unexpected rough weather on their 1,100-mile passages from Bora Bora to American Samoa. Here are the highlights/lowlights of my singlehanded



DESTARTE





strategy that I've always questioned."

*Log entry #3:* "Another day, another good run. The 176 miles is a bit off the recent pace, but only because there was very little wind from 10 p.m. until 4 a.m. I did, however, get hit by a nasty squall. I was roused from a deep sleep by the wind speed and wind direction alarms going off. The wind had shifted direction 90 degrees and the windspeed had jumped from 10 to 30 knots. *Moonduster* gybed in the resulting melee, breaking my main preventer, and somehow breaking the half-inch Spectra afterguy that had been holding the pole back. Having to go on deck in the torrential downpour added to the excitement. I don't know why I took my headlight, as I couldn't open my eyes in the stinging rain. I finally got everything sorted out, enjoyed the shower, and took great relief in the fact that nothing else had been damaged."

*Log entry #4:* "I'm really looking forward to the South Pacific Arts Festival — and a coin-op laundry — when I arrive in American Samoa tomorrow. The last time I had laundry done was in Papeete, where a single load of wash/dry/fold was just a tad over \$50."

*Log entry #5:* "I've arrived and I'm in great shape. I covered the 1,100-mile

**No matter if you're at land or at sea, big squalls are a cause for concern — and a potential source of considerable boat damage.**

***It's natural to think of idyllic weather conditions in the South Pacific, but there can be unpleasant surprises even in tradewind zones.***

passage, as well as my first impressions of American Samoa:

*Log entry #1:* "Oh, this sucks! It's been blowing 25 to 35 knots for over 24 hours, and I'm less than two days into what was forecast to be a reasonably nice trip to American Samoa. The sea state is actually improving a bit, as the waves are starting to mature in shape, meaning they are getting less square and more round. But every few minutes one still washes completely over the boat. Going on deck isn't dangerous, it's silly. I haven't eaten since breakfast yesterday, and I've only got two to three hours of fitful sleep in the last day-and-a-half."

*Log entry #2:* "I chafed a small hole in my main because I couldn't see well enough — despite the full moon — when tucking in the second reef to make sure the main stayed off the spreader. It's just

hard to see when you're getting blasted with salt spray. But I did a 200+ mile day, my first ever. That's miles made good towards Pago Pago, too, measured noon-to-noon. It didn't take flawless tactics, spinnakers, or playing the windshifts. No, it just took a staysail, a double-reefed main, and a cast iron stomach. Unfortunately, I'm still 757 miles from my destination, and the forecast is for the weather to continue to deteriorate. I'm in contact with a slew of other boats, some heading for Raratonga, some for Suwarrow, and some for Aputaki. Some left earlier than me, and I've already passed them. Some left later, but they should have known better. No one is in much trouble at this time. Most are trying to slow down, a





# CHANGES

passage in just six days flat, and had a memorable last few hours. I cleared appropriately named Breaker Point around 1 p.m., at which point I noticed that my electronic charts showed I was on the rocks. My radar and eyeballs disagreed, so I quickly decided that this was yet another case of a chart that hadn't been corrected to the GPS model of the world. I'd come to expect such things in Mexico, where the charts are usually off by as much as half a mile, but I was in *American Samoa*, so I expected more.

The part of Pago Pago harbor reserved for cruising boats is small, has deep water, is windy and crowded, and has a well-deserved reputation for poor holding ground. I won't bore you with the details, other than to say this was the time my fabulous electric windlass decided to take a holiday, and it was only on my third attempt to anchor — and with the help of another cruiser — that I got the hook to get a good grip on the bottom. I was a bit rushed because the talk on the SSB nets had been about how important it was to get checked in before 4 p.m. to avoid hefty overtime charges. So after spending two hours anchoring, I dug out the dinghy, inflated it, put the outboard on, and zoomed off to — drum roll, please — An Encounter With American Bureaucracy.

It was Harbormaster first, then the Harbor Police, Customs, Immigration, and Agriculture. It took me an hour to figure out in which order to visit them. All but Immigration are in one building, but security wouldn't let me in the building

***The Pacific Arts Festival is both figuratively and literally colorful. This guy has such a good look that he could front a rock band.***



MOONDUSTER

because there was a cruise ship tied to the dock and I might have been a terrorist threat. Fortunately, I'd brought my hand-held radio and was able to talk my way in. Immigration was a 20-minute walk for a typical Samoan, but a 10-minute walk for a cruiser like me trying to save \$100. The officials admonished me for many things, none of them important. I was promised that I'd be charged for my crimes when I left, and was given plenty of stamps, forms, and stern looks. By rushing, I completed the process with nearly 15 minutes to spare. Then I realized America is in the next time zone west from Bora Bora, so I really had an additional hour to check in!

I stopped at eight stores trying to track down a pair of CR-123 lithium batteries for my camera, then dashed back across the harbor to get cleaned up for the South Pacific Arts Festival. It was then that I realized *Moonduster* was a disaster. Six days offshore in rough weather will do that to a boat. I tidied up, had dinner, cleaned up, and then devised a strategy for getting back to shore while still looking presentable on arrival. Said strategy included a raincoat, backpack, two T-shirts, a bottle of water, and two hand towels.

My strategy worked, and I walked into town feeling good about the whole ordeal. Going into the main pavilion, I found a spot up front wedged between Jane, an attractive woman from Western Samoa who goes to college in Costa Mesa, and Kate, who had just come off stage after performing with her Tongan dance troupe. I watched in amazement as the next five or six dance troupes from various islands performed a variety of traditional and more modern dances. Kate, who was joined by her four sisters and her mum, talked me through the fact that most of the dancing is based on traditional movements, but using more modern choreography. She went into quite a bit of detail about how most of the movements are modeled after birds, as it's the birds who taught the Polynesians where to find the fish, crabs — hell, even the islands. Kate pointed out that birds don't move their eyes, but rather their heads, and all of a sudden it all began to fall into place. Either that or the beer I'd been drinking started to take effect.

The crowd was a diverse group of people from age 2 to 80. They were attentive, well-behaved, and very much into the remarkable performances of their cultural heritages. I couldn't help but contrast their heritage to ours in the United States. You know, Britney Spears,



the Mouseketeers, *People* magazine, Court-TV, and reality television shows.

The dance program finished sooner than I'd have liked, but the main attraction was still ahead — a rock band of Samoan natives, now living in Nashville, who had scored a big hit in America. I fancy myself to be somewhat informed on the rock scene in the States, but I'd never heard of this band. Kate and Jane were shocked. There was lots of fanfare as the musicians took the stage. The first song was apparently a somewhat traditional Samoan number, as everyone sang along. The rhythm section was good, and the guitarist — clearly a white kid from Nashville — had some pretty decent chops. For a few minutes I dared to think it might be fun. But the lyrics of the next song were displayed on a huge projection TV behind the band — and I couldn't





MOONDUSTER

**The Pacific island heritages celebrate grace and beauty; in the U.S., our heritage celebrates subhuman characters from reality TV shows.**

I believe my eyes. This was a Christian rock band! The crowd knew every word, every nuance, every move — as if Jesus Christ were the second coming of Jerry Garcia, and might also soon have an ice cream flavor named after him.

I tried to stay, observe, and be patient with the crowd, the band, and even with myself. But I just couldn't. So I returned to my dinghy, wrestled with the lock for three minutes, then took off across the harbor. Halfway to my boat the outboard died. The wind-driven waves and rain remained very much alive, however. I ultimately discovered that the fitting that connected the fuel line hose to the engine had come off. A few minutes later I was in flight again, a little annoyed and

completely soaked.

As I finished putting the outboard and dinghy away, what seemed like the mother of all squalls descended on Pago Pago. It dumped a most remarkable, cow-pissing-on-a-flat-rock deluge of water on the throngs churning away to the latest gospel hits from Nashville to your favorite South Pacific Island. As I washed Pago Pago away in a hot shower, I thought to myself that maybe there was a God after all, and maybe she shared my sense of humor.

If I sound as though I started out pretty down on American Samoa and Samoans, I ended up spending three weeks and came to love

the people and place. But that report will have to wait for next month. I'll be departing American Samoa for Tonga in about a week, and then will continue on to New Zealand for a summer of cruising in the southern hemisphere. Later, I'll put the boat on the hard to give her a new rudder. I'm really sick of the unbalanced skeg-hung monstrosity she's got now, and I've got a some good ideas on what to do and where to get it done in New Zealand.

— wayne 08/15/08

**Caribbean Soul — F/P Eleuthera 60  
Steve Bonner  
Grenada, A Slice Of Nice  
(San Jose)**

When I bought my big sailing cat 27 months ago, my plan was to sail around the world over a five-year period, doing charters as I went along. All the while I would seek the perfect place to throw down the anchor and stay awhile. I started by sailing through France and the rest of the Med, down to Egypt, and across the Atlantic, but have spent the most recent eight months sailing up and down the islands of the Eastern Caribbean. Rather than continuing on with my circumnavigation, I find myself still here in the Caribbean, specifically at the verdant, volcanic Grenada, aka the 'Spice Island'. Plans change, don't they? As I've found my Shangri-La, my new plan is to stay in the Grenada area at the bottom of the Eastern Caribbean and develop a much-needed luxury charter business.

It was four years ago that 10- x 20-mile Grenada was forced to change its plans. After not being hit by a hurricane in something like 150 years, they took such a direct hit from *Ivan* that 95% of all buildings were destroyed. The slow and peaceful island was absolutely devastated. The good thing about not having

**Alicia Holm and Johanna Lenk take a break among Grenada's lush vegetation to hydrate during the Seven Lakes hike.**



CARIBBEAN SOUL



# CHANGES

much to begin with is that you don't have to do much to get back to where you were before you took the hit.

The Grenadians wanted to do more than just recover, however, and decided



**Grenadan blue and green.**

that tourism would be their vehicle of change and progress. As such, the population of 100,000 — minus a small environmental contingent — is enthusiastically supporting no fewer than 15 major

tourism projects, including a Ritz-Carlton Resort. In addition, the 200-year-old British firm Camper & Nicholson bought out the interest of Brit Peter de Savary — who once backed an English America's Cup team — in the massive 364-berth Port Louis Marina project. The idea is to provide the kind of facility necessary to attract large yachts, including some megayachts, to the Eastern Caribbean south of Antigua. Yes, the little island of Grenada is looking to make a big splash.

Many *Latitude* readers have sailed — or thought about sailing — in the Eastern Caribbean for all the well-known reasons: consistent tradewind sailing, beautiful warm water, tropical temperatures, terrific diving, white sandy beaches, rum, and a more relaxed pace. And it is fantastic. But as veterans of the Caribbean know, there are some

***Don't take life so seriously. Grenada holds their Carnival in August. What next, Christmas in July and New Year's on April 1? Yeah, mon.***



CARIBBEAN SOUL

downsides to some of the islands. For example, the beautiful and plentiful anchorages in the British Virgins tend to be crowded, the food is indifferent in places like Dominica and Anguilla, the locals can be surly in places like Guadeloupe and St. Vincent, and violent onshore crime can be a serious problem in the U.S. Virgins, St. Martin, and Trinidad.

The reason I'm basing out of Grenada is that it has all the good qualities needed for a great sailing experience, but with few of the negatives. The sailing and weather are splendid, of course, but there are also plenty of unspoiled anchorages and beaches. There is good food to be had, although it's not as good as St. Barth or St. Martin. But perhaps the biggest attraction is that the locals are friendly and that the island is one of the safest in the Caribbean. Women tell me they feel comfortable walking alone anywhere during the day — and most places at night — because they don't get hassled.

Unlike St. Thomas, Trinidad, and St. Martin, the people of Grenada have come together as a community to weed out — or at least recycle — their bad seeds. The island mentality on Grenada is for everyone to live positively and do no harm to others. Drug dealers, street hustlers, and beggars are a rare sight in Grenada. When discovered, dealers are dealt with harshly. In fact, the Grenadians might even go a little overboard with law and order, as both camo clothing and homosexuality, as in some other islands, are technically illegal. The government is very strict on criminals, particularly the few who target tourists. There was a minor theft from a dinghy at the north end of the island, and by the next day the police had the four culprits in jail and the stolen stuff returned.

Grenada is one of the few Eastern Caribbean islands with a spectacular jungle rainforest. You can hike up to the various waterfalls and peaks by yourself, or you can hire a guide. Every other week there is a 'hash hike', which is a hike led by a guide but is still free for anyone. About 15 friends and I hired a guide to do the Seven Sisters Falls hike, and we had a blast. The hike was terrific, as we saw wild parrots and other animals, and the guide knew all about the island's plants and history. He even showed us where



to jump off the waterfalls — all seven of them. It was a good thing, as that was the only way to get back down. Even the most terrified of us survived, and we were all smiles at the end of the day.

Need one more reason to take a sailing vacation at up-and-coming Grenada? How about the fact that they celebrate Carnival in August? Yes, I know Carnival is all about Lent and Easter, but down in this part of the Caribbean the people aren't afraid to do things their own way.

— steve 08/05/08

**Gallivanter — Hylas 49  
Kirk, Catherine & Stuart McGeorge  
Starting Our New Cruise  
(St. Thomas, U.S. Virgins)**

We've been on the move for 10 weeks since departing our former home in St. Thomas, and our log shows that we've already visited more than 35 places on 25 different islands in the Caribbean. All have been good, while some have been sensational. Our favorite places have



# IN LATITUDES



PHOTOS COURTESY GALLIVANTER

**In the first 10 weeks of their current cruise, Kirk, Catherine, and Stuart have visited 25 islands — including Antigua. This is English Harbor.**

been St. Barth, English Harbor at Antigua, Martinique, Wallilabou, the Pitons at St. Lucia, the Tobago Cays, and our current location inside the lagoon at St. Georges, Grenada.

The folks here in Grenada are among the nicest we've met in the Caribbean. There's a big community of global sailors riding out the storm season here, as Grenada is on the edge of the hurricane zone, so there seems to be a BBQ or potluck somewhere every evening. We survived Carnival — yes, it's August — last weekend. But the music was so loud that it damaged the microphone in my video camera!

Everything on the boat is getting settled in, and we're getting accustomed to our completely refurbished new old boat. Nothing has broken, and things are turning out even better than expected!

There are heaps of good hurricane holes along the south coast of Grenada,

so we plan to relax around here a while and do some boat upgrades in preparation for our next leg west along the offshore islands of Venezuela and Colombia. From there, we'll head to Panama.

— kirk 08/14/08

*Readers — We primarily ran the Gallivanter report to confirm Steve Bonner's impressions of Grenada, as the former's judgment could have been compromised by his business interests. In an upcoming month, we're going to run Kirk's long account of buying an Islander 37 in Hawaii, sailing her around the world over the course of several years, buying a used boat, and refitting her for their current cruise. Juicy stuff.*

## **Raptor Dance — Valiant 50 Bill Finkelstein and Mary Mack Tips For The Class of '08-'09 (Santa Rosa)**

Mexico has gone through a lot of changes since we first arrived here in '04, so we'd like to share some news and thoughts with new and returning cruisers.

**Provisioning:** Provisioning in Mexico is better and easier than ever. Puerto Vallarta has long had a Sam's Club, but a few months ago it got a new Costco and Home Depot. While the product selection is a little different than in the States, you'll find most of your old favorites. Actually, you'll find big box *supermercados* at all the major cruising centers — Cabo, La Paz, Manzanillo, Zihua, and so forth. The one place where provisioning remains a challenge is north of La Paz in the Sea of Cortez. When we first arrived in Mexico, it was hard to find things such as quality Washington State apples, good lamb, Balsamic vinegar, Asian sesame oil, high-end chocolates, and chopsticks. All these things are now widely available.

Despite the convenience of the big box stores, absolutely don't ignore the traditional local markets, which have more exotic stuff and are more fun. There are huge daily markets in places such as La Paz, Mazatlan, P.V., and Zihua, but also weekly markets in places such as Jarretaderas and other small towns. The local markets have more interesting things for sale than the big boxes and the vendors are more colorful. Many of them have excellent low-cost places to eat.

It's still hard to find great wines in Mexico, so we recommend that you bring what you like along with you. Nonetheless, you can find 'drinkable' Mexican and Chilean wines that are better than 'Two-Buck Chuck'. The beer and margaritas in Mexico are excellent.

Be aware that some foods will be confiscated at your port of entry. Among them are beef, chicken, and fresh eggs. If you don't pull into a slip at your port

**Welcome to 'new' Mexico. When Costco opened in Puerto Vallarta earlier this year, locals formed long lines to get their membership cards.**



LATITUDE/RICHARD



# CHANGES

of entry — most likely Cabo — your boat probably won't be inspected. Nonetheless, there's plenty of great beef, eggs, and poultry to be had at Mexican big box stores, so why take the chance?

**Food and Water Safety:** Food safety and sanitary conditions in restaurants seem to be improving all the time. We've



*Food and water are becoming safer all the time.*

yet to come down with a food-borne illness — as opposed to *turista* — in the four years in Mexico, although I did get food poisoning once in the States. We're reasonably cautious, and because we've done a lot of Third World travelling, feel comfortable eating at most restaurants and street vendors. We do, however, look around first to make sure things seem reasonably sanitary. We wash our fruits and vegetables the same way we do at home, and don't use bleach or fancy chemicals to 'sanitize' them. Interestingly, you can buy some of the same pre-washed salad stuff — greens, carrots, etc. — that you can in the States.

Everybody wonders about the water in Mexico. We fill our water tanks with water from the marina supply — and the watermaker when at anchor — and we do drink that water. However, we have a Shurflo filter going into the tank, and a General Ecology filter on our drinking tap. We really like the General Ecology filter, as it takes up a lot less room than a bunch of bottles of water that some

**Few things are more important on a cruise to Mexico than a reliable dinghy and outboard. This is a yellow one, but any color will do.**



LATTITUDE/RICHARD

cruisers seem to prefer.

**Boat Cards:** Many first-time cruisers forget to make boat cards, which turn out to be very useful for helping cruisers remember all the new people they meet. It's especially helpful if people put their picture on their boat cards, as you'll meet so many people it's hard to keep them straight without a photo to remind you of who is who. Make sure the type on the card isn't too small or fancy to read, and that it includes the following information: your name, boat name, boat type, hailing port, email addresses, cell/sat phone numbers, SailMail/Winlink addresses. You can buy business card paper at office supply stores and print your own, but it's often not much more expensive to have an internet printing company do them.

**The Dinghy and Outboard:** Most first-time cruisers don't appreciate how important these two items are until too late. You're not only going to use these almost every day, but they will be your only way to get between your boat and shore. If you love to explore, you'll want an outboard powerful enough to plane. If you're not big on exploring, you can get away with something as small as 5-hp. No matter what you do, buy a quality dinghy and outboard, and make sure you have a good system for raising and lowering them. Without one, your boat can become something of a prison.

**Shade:** If you haven't lived outdoors in the tropics, you don't know how powerful the sun is. You'll absolutely want lots of shade, both while sailing and at anchor.

**Potluck Tips:** When you cruise in Mexico — perhaps the most social cruising area in the entire world — you're going to be participating in a lot of potlucks. After a while, everybody gets tired of the same old common contributions of things like carrots and chips. If you buy an appetizer/potluck book, you'll get lots

of ideas for tasty finger foods. Fresh ingredients are easy to find in Mexico, so it's not hard to make an effort.

**Learn to Speak Spanish:** Unlike French or Russian, Spanish is not difficult to learn. Buy a *Spanish Made Simple* book — spend 10 minutes a day, and you'll be surprised at how quickly you pick things up. Besides, you don't have to be fluent to enjoy the benefits.



**Enjoy the Local Culture:** Mexico is a fascinating country with a rich, family-oriented culture with great traditions, in music, dance and other things. It has great quirks, too. Unfortunately, lots of cruisers never get away from the cruisers' culture — and yes, we certainly have one — to sample what Mexico has to offer. And don't forget an inland vacation from cruising to Oaxaca, Copper Canyon, Guadalajara, Colima, Guanajuato — or Tequila!

— bill and mary 07/15/08

**Sailor's Run — Baba 40  
Jeff and Debbie Hartjoy  
Seldom-Visited Honduras  
(Longbranch, Washington)**

Debbie thought our three-week stay in San Lorenzo, Honduras, went way too fast, and I have to agree. San Lorenzo is one of those spots — and we've already spent seven years cruising the Pacific, so



# IN LATITUDES



LATITUDE/RICHARD

**When it comes to living life to the hilt, few can match Debbie Hartjoy, seen hear fronting the Ha-Ha band at Bahia Santa Maria in '06.**

we've been around — that has you asking yourself, "I could live here, so why are we leaving?" The people are that warm and friendly, tourism is limited to Hondurans from the interior, and only six cruising boats visited last year. Fortunately, our friend Dayle was on one of those boats, spent 12 months here, and encouraged us to stop.

San Lorenzo is also one of those places where people are content with their simple lives and won't be inclined to change things anytime soon. As such, when we walked down the street, nobody tried to drag us to this place or that, or to get us to buy something.

Honduras was visited by the Spanish back in the time of Columbus, and the locals were — as was normal back then — robbed of their mineral wealth. The

Spanish left after 300 years, but there is still a Spanish Catholic Church in every major town. Nonetheless, the Hondurans see the cross as a 'sword' that was used to rob them. One thing for sure is that visitors don't get robbed in San Lorenzo. Just one U.S. dollar will buy you three of the most delicious head-sized catapoupes that you've ever tasted, a beer in any restaurant, or a large two-scoop ice cream cone. Well, you might have to throw in another 25 cents for the latter.

Dayle introduced us to Armando and Jose, owners of the Porlamar Restaurant Bar, and their kids. This resulted in us getting connected to the community, as Armando's father used to be the mayor and remains one of the most popular people in town.

The Porlamar is flourishing, and the food is delicious. Wait, I can't tell a lie — the hamburgers need some help. But the beer, which is so cold that it has ice in it, makes up for it.

Debbie and I were invited to all of Armando and Jose's family events, including daughter Scarlett's 15th birthday celebration, which is and known as *Quiñeanera*. This is a really big deal, so the parents pulled out all the stops — free food and drinks, live entertainment, a D.J., and a fantastic sound system. Debbie even got a chance to sing. There was lots of dancing, and even though I'm 61, Debbie and I pretty much ruled the dance floor. A great time was had by all.

When we left San Lorenzo, I'm pretty sure we said that we'd be back. Since the price for checking in and out of Honduras is just \$2.50, there is no financial reason not to return. Besides, the people made us feel as though they were so happy to have us visit.

The passage to our next stop, Ecuador, was to be over 1,000 miles. And to think that I'd told Debbie there would be no more long passages! "Fine," I said when she objected, "we'll go by way of Costa Rica's Cocos Island, which is right on the way." Deb thought that was great — until I found out it had become such a big tourist site that they now wanted to charge boats \$85/night — to anchor! We've seen some nice islands and anchorages in our time, but we'll never pay \$85/night to anchor.

Anyway, we set sail on April 15, and managed to get all of 100 yards from the anchorage before the wash down pump blew off at the waterline, pumping 20 gallons of saltwater into the locker filled with toilet paper. Thank God all the TP was in a plastic bag, as only two rolls got ruined. We dried the rest on the deck. Soon everything was fixed again, and

**The local fishermen were bemused by Jeff and Debbie's spinnaker handling — and dumbfounded that they were headed to Ecuador.**



SAILOR'S RUN

# CHANGES

with the anchor stowed on deck, we wove our way out the unmarked channel. We never saw less than 15 feet.

Once we were clear of the channel, we angled across the Bay of Fonseca for the northwest tip of Nicaragua, which was about 15 miles in the distance. There were many curious fisherman about in small wooden boats who watched us try to fly the spinnaker in dying winds. We finally bagged the spinnaker as six fishermen looked on and wondered what the crazy *gringo* couple was doing. It had to surprise them even more when Debbie told them we were on our way to Ecuador.

Suddenly the wind piped up on our port beam, and we took off. With the Papagayo winds coming down out of the mountains at 25 knots, we logged 130 miles the first day. By the next day we were 75 miles offshore and had winds to 30 knots. We are pretty comfortable in beam seas to about 12 feet. They got close to that size, but the crests weren't blowing off. Despite the wind dying toward the end of the second day, we managed to cover 144 miles. By the third day we were down to 79 miles. But I didn't feel too bad, as it was my 62nd birthday, and Debbie made me a pizza and gave me a couple of cold ones to celebrate.

Then a patrol boat approached, and later a military plane flew overhead. It's obvious someone is patrolling these waters, but that we aren't what they are looking for. The rest of our passage was pretty much uneventful. Other than having two waterspouts nearby at the same time, the forestay coming down, confronting mysteriously rough seas, and having to dodge lots of ships coming out of the Canal, not much happened.

**After all the years and thousands of cruising miles, Jeff and Debbie still love the cruising life. And Jeff is looking to Cape Horn.**



We'll share our thoughts on Ecuador, where there is both good and bad, next month.

*Update:* We're currently our way from Ecuador to Callao, Peru. We've been sailing against the Humbolt/Peruvian current for 14 days now. Although the direct sailing distance from Bahia, Ecuador, to Callao, is only 800 miles, we've already sailed double that beating to weather, and still have 150 miles to go!

— jeff 05/15/08

## **Tawodi — Customized 39 Stephen Mann, Kathleen Torres Around The World In 7 Months? (San Diego)**

Stephen Mann first lived aboard a sailboat when he was 12. At 17, he and his father sailed to Mexico. After only a few months, his dad took off to join Stephen's soon-to-be third stepmother in Panama, leaving young Stephen in charge of the boat. "I cruised around for two more years before deciding I'd better come home and get a job," he says.

Few sailors have been immersed in the cruising life so early or so thoroughly. And Stephen was a natural — witty, intelligent, good with his hands, and quick with a smile. He took the ball and ran with it, parlaying those early experiences into a career as a licensed captain and rigger. Based out of San Diego, he now holds a 500-ton Ocean Master's ticket, has skippered tugboats, and delivers yachts all over the Pacific and beyond — including 18 trans-Pacific trips and countless runs down to and back from Mexico. He also runs his own rigging service, and has worked on everything from weekend warriors to America's Cup boats. For pleasure, he continues to enjoy his 39-ft sloop *Tawodi*. All this and he's still only 37 years old.

*Tawodi* — it means 'hawk' in Cherokee — was built at Westerly Marine in Southern California. But the boat has been so thoroughly modified that her originally designer no longer wants to claim her. She might as well be called a Mann 39. Among the more visible changes, Stephen molded a new, plumb bow over the old one. This gave the boat more than 3,000 extra pounds of flotation forward — and a nice crash bulkhead. The list of changes to the interior would require a couple of more pages. Basically, he has all the electronic and navigational bells and whistles any modern cruising boat could wish for, as well as a sound system



unrivalled in the animal kingdom — and 1,000 CDs to go with it. Performance-wise, the boat has gobbled up more than 100,000 miles under Capt. Mann, most of them cruising, and a fair amount of them singlehanded. Although Stephen doesn't race much, about 4,500 of the latter miles were chalked up when he sailed the 2000 Singlehanded TransPac and then back to the mainland.

Now Stephen is planning an adventure so unique we almost think it's crazy. Actually, we do think it's crazy, but in a good way. Starting in October, he'll be sailing around the world — at a "race pace." That means 22,000 miles in only eight or nine months, and with only five stops. Why? "It sounds like fun," he explains.

The project has been percolating in Stephen's mind for years. The inspiration, he says, came about as a result of his participation in the '00 Solo TransPac. "When I returned to San Diego, I got some money — retroactive sponsorship



# IN LATITUDES



BOTH PHOTOS COURTESY TAWODI

**Spread; 'Tawodi' was launched in '90 — with the rig from a CSY motorsailor! Stephen and Kathleen are both avid bicyclists. He rode across county in '99, and neither of them own a car.**

I guess you'd call it — from a friend. He hinted that there might be more if I was interested in doing a BOC (now Velux 5 Oceans) or Vendée Globe. I was very interested, of course, but then came the dotcom crash, and the money went away. But that's where the seed was planted."

Stephen won't be flying solo this time, however. Kathleen Torres, his partner of several years, will be coming along as mate, companion, chronicler — and "medical kit." "She's a universal blood donor, so that might come in handy," jokes Mann. Kathleen is also a skilled sailor, and will play an integral part in the project.

The stops Stephen and Kathleen expect to make are not set in stone. But at this stage of the planning, they are: Ushuaia, Argentina, which is near Cape Horn; Cape Town, South Africa; a 2.3-square mile dot in the Indian Ocean

called Ile Saint-Paul; "somewhere in Australia"; and perhaps one more stop in the Pacific. Kathleen's currently lobbying for Easter Island. Stephen also envisions the trip as a 'classic' roundabout, meaning they'll go west-to-east, south of the five great capes.

Although Mann and Torres would certainly welcome any donations of gear or money, so far the impending adventure is purely on their own dime — and is doable that way. A meticulous planner and inveterate tinkerer, Stephen even plans to grow sprouts hydroponically as they go. These will supplement all the canned, frozen, and dried stores that they will carry.

Stephen and Kathleen had the boat out of the

water for one last overhaul and painting in August. By the time you read this, the boat should be back in the water, Kathleen will have quit her job, Stephen will be finishing up any last minute business, and they'll both be saying goodbyes.

For a point of reference, it's common for cruisers to take three to five years to do a circumnavigation. But we've known several who have done it in less than two years, and last year Mike Harker did a mostly singlehanded circumnavigation — using the Panama Canal — in 11 months with his Hunter Mariner 49 *Wanderlust III*.

— latitude/jr 08/16/08

## Cruise Notes:

One thing almost all cruisers learn is, when shit happens, you've simply got to breathe deep and deal with whatever problems have arisen. That's exactly what a group of westbound cruisers did after getting hammered by unexpectedly strong winds on their way from Bora Bora to Suvarrow on July 18-20. As reported in the last *Latitude* and in *Lectronic*, both the Seattle-based Bristol Channel Cutter **Little Wing** and Steve and Wendy Bott's Seattle-based J/44 **Elusive** suffered substantial damage in those rough conditions. *Little Wing's* mast was totalled, and *Elusive* suffered a cracked gooseneck and torn main. Now for the good news. According to John and Renee Prentice of the San Diego-based Serendipity 43 **Scarlett O'Hara**, the folks at Forespar have modified their production schedule so they could immediately start work on a new mast for *Little Wing*. In fact, the mast should be on the way to *Little Wing* in American Samoa by the time you read this. *Little Wing* was able to make it to American Samoa thanks

**Steve and Wendy Bott's J/44 'Elusive' required repairs to the main and a new gooseneck. Shipping should be quick to American Samoa.**



LATITUDE/ANDY



# CHANGES

to donated jerry jugs of fuel from other cruisers, and because the folks on **Fearless** volunteered to escort her. As for *Elusive's* main, it was damaged badly enough to have to be shipped back to the States for repair. And Hallspars, which made her original gooseneck fitting, is sending a replacement. **Scarlett O'Hara** escorted *Elusive* to American Samoa. "The one good thing about all of this," notes Prentice, "is that both boats can be repaired in American Samoa which, because it's part of the United States, has excellent shipping and is serviced by the U.S. Postal Service. That speeds up things as opposed to trying to get things repaired or replaced in Tonga or Fiji. The other thing to note is how the cruising community has once again stepped up to her cruisers who were in need."

If you're planning to 'commuter cruise' out of the La Paz area — or just about anywhere in Mexico — this winter, you should act immediately to secure a slip. Mary Shroyer of **Marina de La Paz** reports that they've had higher than normal occupancy for the summer, which means they'll be "all but filled



GLENN TWITCHELL

*With nearby island anchorages such as this, La Paz is one of the more popular bases for commuter cruisers. Reserve your slip now!*

up starting November 1." Harbormaster Garbriel Lay at **Costa Baja Marina** reports that their 250-berth marina has been running at 85% occupancy during the summer, and will quickly fill up at

the start of the season. "Right now I've got 12 40-ft slips, six 35-ft slips, and a few 50-footers, but that's it. And that's even with the new prices, which mean 40-ft slips are \$16.80/ft/month, not counting the 10% tax. Folks with 150 to 200-ft boats — and we've had 160 boats that are 100-ft + in the last three years — pay over \$40/ft/month. If you build a marina in the La Paz area, the boats will come. Even the **Fidepaz Marina** — which is way down the bay and as yet without channel markers for its tricky channel — has a number of larger boats now."

And to think that the number of slips in La Paz has doubled in just the last three or four years. The good thing to remember is that you can anchor for free all over Mexico, and in many instances just outside a marina. So how does that help if you have to leave your boat to fly home? In the past, many skippers who did the Ha-Ha became such good friends with other skippers, that the friend would watch over their boat while they returned home for a period — usually relatively short — of time. We're not

## McDERMOTT COSTA

insurance brokers - est. 1938

### Commercial Operations

- COMMERCIAL POLICIES  
Marinas, Yards, Yacht Clubs, Brokers, Shipwrights

### Pleasure Yachting

- YACHT & BOAT POLICIES  
Offshore, Coastal, Inland and Liveaboards



Lic. #OB21939

Bill Fowler

McDERMOTT COSTA INSURANCE  
(925) 606-6606 Fax (510) 357-3230  
bfowler@mcdermottcosta.com



## DON'T TAKE A CHANCE ON YOUR BOAT SINKING!

Upgrade your boat's plumbing using state-of-the-art, noncorrosive Marelon® plumbing fittings.



"The most common cause of dockside sinkings were found to be the result of deteriorated or corroded fittings such as intakes, seacocks and drains below the waterline"

Boat U.S. News - 12/07

### PRECISION MOLDED PLUMBING SYSTEMS FOR ABOVE & BELOW THE WATERLINE

- Corrosion Free
- Electrolysis Free
- Extremely Strong
- Lightweight
- Minimal Maintenance
- U.L. Approved
- A.B.Y.C. Compliant
- Made in the U.S.A.



**FORESPAR®**  
**MARELON®**

www.forespar.com Tel: 949 858-8820 - E-Mail: sales@forespar.com



recommending it, just pointing out that it's not uncommon.

In other La Paz news, **Palmar Marina**, which is next to Marina de La Paz, is getting a second, larger Travelift to handle the greater number of larger boats cruising the area. As for Marina de La Paz, they're putting in a new 240-ft dock/floating breakwater that will add 10 side-ties — "unless a mega yacht comes and takes up most of the space." This new dock, to be in place in October, will come off the end of the existing 160-ft outer dock at a 22 degree angle, and will therefore also protect the marina's inner docks from northerly chop. New and returning mariners to the La Paz need to be reminded that the channel markers at the entrance to La Paz Channel have been moved south to permit the tankers to tie up perpendicularly at the Pemex refinery. This makes entering the channel a little tricky, as it's completely different from before, and requires a 90-degree turn near Marina Costa Baja. This makes it very easy to confuse the third red buoy for the second red buoy, and

for skippers to drive their boats right up on the sandbar. Moving from the water to the air, **Aero California** is no longer flying, so it's good to know that La Paz is now being served by two Tijuana-based airlines, **Alma** and **Volaris**. They have promotional tickets for as low at \$80 each way.

In last month's *Changes*, we featured 26-year-old Andrew Vik of San Francisco, who purchased the much-travelled Islander 36 **Geja** in Italy earlier this year, and is now cruising the Med. When we asked him what he's been doing for the last month and how things are going, he replied as follows:

"My God, where do I begin?! I last wrote from Porto Cervo, Sardinia. Since



*Mt. Etna can really go off, so it's just as well Vik wasn't on it when it erupted like this. Not even the Balkan babes could compare.*

then my whirlwind tour has taken me to Sicily, the Aeolian Islands, through the Straits of Messina, past — and up to — Mt. Etna, down to Syracuse, and around the boot of Italy. I'm finally in the Adriatic, where my journey will end sometime next month. I stopped at Budva, Montenegro, which was com-

## YOUR SECRET PARADISE...



*Located in a beautiful sheltered lagoon on the north Pacific coast of Nicaragua, Marina Puesta del Sol is your premier cruising destination in Central America*

- ◆ Onsite Immigrations & Customs
- ◆ Full service restaurant and bar
- ◆ 24 hour security patrol
- ◆ Internet & Fax/copy service
- ◆ Yacht club with showers and laundry



- ◆ 140 foot fuel dock - diesel/gasoline
- ◆ Well marked channel
- ◆ 40 slips with water, power and cable TV
- ◆ Two pools, oceanside and marina
- ◆ Tennis, surfing, fishing, horseback riding
- ◆ Luxurious hotel with 19 executive suites



# Marina Puesta del Sol

Aserradores, Nicaragua • 011 (from US and Canada) 505-883-0781 mpuestadelSol@yahoo.com • www.marinapuestadelSol.com • USA 408-588-0017

...IN BEAUTIFUL NICARAGUA

# CHANGES

pletely off the graph, as it was swarming with Balkan babes in bikinis. I've never seen anything like it! Why our government makes it difficult for these women to get tourist visas is beyond me. As for Montenegro's Gulf of Kotor, it's awesome — like sailing through a Norwegian fjord, but warmer. It's August as I write this, and since all Europeans go on vacation in August, I haven't been getting much sleep. I finally managed to pry myself away from Budva, and work my way up to Dubrovnik, Croatia. I'd hoped to send some new photos of my voyage, but good internet access is surprisingly hard to find, even here. Besides, I've been too busy sailing and partying. The good news is that all my passages and the notorious straits are behind me. The bad news is that I'll have to leave the boat here in Croatia in less than a month. I've had six different crews so far, including Rob and Christine Aronen, who I met when they sailed **Nomad**, their previous boat, in the '06 Ha-Ha. They now live in Luxembourg, and before my cruise is over, will have joined me on *Geja* on three different occasions. Most of my other crew are friends and acquaintances from the



LATITUDE/RICHARD

*Although this photo was taken in the Ha-Ha, ARC boats can expect similar downwind conditions — but usually with a lot more wind.*

Nordic countries and Germany."

The **Atlantic Rally for Cruisers** (ARC), the granddaddy of all cruising rallies, continues to sell out each year. The 2,700-mile event from the Canary

Islands to St. Lucia in the Eastern Caribbean reached its maximum of 225 entries as of April 29 — more than six months in advance of the November 23 start! And unlike the Ha-Ha, it's not inexpensive to enter. Despite the increase in the value of the euro for most of '08, the United States will be represented by 11 boats this year, up from seven last year. The American entries are: Frederick Stelle's J/145 **Ace**; John Kennell's S.J. 48 **Amulet**; Jose de Yturbe's Hanse 630 **Ayachucho**; David Harris' Norseman 43 cat **Gone Native**; Joseph Barnette's Island Packet 40 **Hope and Glory**; Philip Stolp's Hallberg Rassy 53 **Souverain**; Lurelle Verplank's Oyster 82 **Sundowner**; Dana and Glenn Meyer's Centurion 40 **Mahalo**; Bill Dwyer's Pearson 424 **Overdraft**; and Hardy's Good's Amel 54 **Patti G**. Unfortunately, we don't know how many — if any — of these entries are from the West Coast. As some of you are aware, the European economies are widely expected to take a later, longer, and deeper dip than the U.S. economy, which would likely result in the dollar increasing upon its recent 8% gain

## SAL'S

INFLATABLE SERVICES, INC.



*Cruisers...Call Sal & Silvia!*

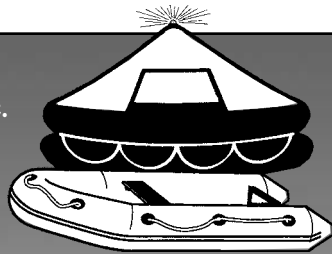

### GOING CRUISING?

**Offshore or anywhere -  
you'll be safer with Sal's!**

**Liferafts • EPIRBs • Flares • More**

**See us at the Latitude 38 Crew List Party Sept. 10**

USCG APPROVED LIFERAFT FACILITY for USCG/Solas, Yacht and Fisherman Life Rafts. Life raft sales for Avon, Mitsubishi, Fujikura, DBC, Givens, Plastimo, RFD-Revere, Switlik, Viking, Winslow and Zodiac. Inflatable boat sales and warranty repairs for Avon, Achilles and Zodiac. Sales of ACR and McMurdo EPIRBs, signal flares USCG/Solas type and Survival Technologies MOM units.

**PHONE (510) 522-1824 FAX (510) 522-1064**

1914 Stanford Street, Alameda, CA 94501  
salsinflatables@sbcglobal.net • www.salsinflatablestervices.com

## MARINA REAL

SAN CARLOS, SONORA, MEXICO

### IN THE SEA OF CORTEZ

Located on the Mexican mainland near Guaymas and San Carlos, 265 miles south of Nogales, Arizona.

- 350 slip marina • 20 & 30 amps electrical service
- 24-hour security patrol
- Fuel dock with gasoline/diesel
- Restrooms & showers
- Web email • Fax/copy service
- Port entry clearance
- Book exchange • Video loan library
- Ice & bottled water
- Wet storage for summer months (low prices)

**Now Offering:**

**Haulouts, Dry Storage & Service Yard**



Phone/fax 011-52-622-2270011  
Call on VHF #16 when in area  
email: [marinareal@prodigy.net.mx](mailto:marinareal@prodigy.net.mx)

Visit our website:  
[www.marinareal.bravehost.com](http://www.marinareal.bravehost.com)



against the euro. If such a trend continued — and we're not suggesting that you bet your cruising kitty on it — boats and cruising in Europe would become less expensive than they've been, and U.S. participation in the ARC might return to what it was 15 years ago. We know that we'd love to do another ARC.

As of August 17, the **Caribbean 1500 Rally**, which departs Hampton, Virginia, on November 2 for the 1,500-mile distant British Virgins, reported 32 paid entries. All of them are from the East Coast.

"We've been most distressed to learn that the British Virgin Islands, where we hoped to cruise on our way south to Isla Margarita, Venezuela, this winter, has decided to institute harbor fees, which are to be in addition to all their other fees," report Ed and Sue Kelly of the Iowa-based Catalac 36 catamaran **Angel Louise**. The couple, who are currently on their boat in Connecticut, note that the BVI government has proposed charging private yachts not owned by citizens \$1/foot for the first day in the islands, 75 cents/foot the second day, and 50 cents/foot a day for every day after that.

Ouch! The Kellys figure it would cost them about \$800 a month in harbor fees alone to enjoy the BVIs. "That wouldn't make sense to us, so we guess we'll take our money and go elsewhere," they write. Others have speculated that these fees would make the British Virgins one of the most expensive places in the world to cruise. Ralph T.

O'Neal, the Premier of the British Virgins, was undeterred by such sentiments, saying the harbor fees were a source of tourism revenue that the BVIs could no longer afford to not collect, as all steps needed to be taken to put the country's financial house in order. Boats were to be subject to the new fees on July 15.



*Officials in the British Virgins came to their senses at the last moment and canned the proposed to charge private yachts harbor fees.*

Government officials the world over, of course, think the solution to every financial problem is impose to a new tax. Business people know that's often counterproductive. So before the new fees could go into effect, O'Neal and other government officials were given a lesson in *Economics 101* by members of the

**SAILBOATS ONLY**

[www.hiddenharbormarina.com](http://www.hiddenharbormarina.com)

**SURVIVAL TECHNOLOGIES**

**MOM8-A<sup>®</sup>**

**Man Overboard Module**

Manufactured By

**SWITLIK**

Switlik Parachute Co., Inc.  
Trenton, NJ

609.587.3300      [info@switlik.com](mailto:info@switlik.com)

# CHANGES

country's marine and tourism industries. The business people explained that the new draconian fees would destroy the BVIs' competitive advantage over other cruising destinations, and the result would be lower net revenues for the government. O'Neal and the legislators have good ears, so the proposal for harbor fees is now dead, and the government is searching for someone else to tax.

By the way, the Kellys report, "we sold our house and all our stuff, and have been cruising 18 months now — due to dreams *Latitude* ignited in us two Iowans." Well, good on you.

"The **secret to happiness is freedom**," wrote the ancient Greek historian Thucydides. And there's some compelling data to back him up. Since '81, 350,000 people from 90 countries have been asked how happy they were. Despite all the apparent gloom in the United States, close to 80% of the respondents for which data had been data collected for more than 10 years said they have become happier. There are two reasons. First, for many millions of people, the threat of starvation has greatly dimin-

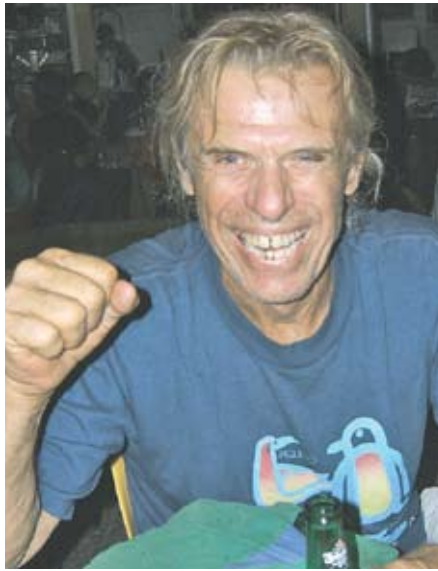

LATITUDE/RICHARD

**You don't need a lot of money to be happy. Jim Green started one of his three circumnavigations with \$150 — and still had a great time!**

ished. It's hard to be happy if you and your family are starving to death. Once food and basic shelter have been taken care of, the greatest predictor of happiness is income. All right, all right, we're

just kidding. The second best predictor of happiness is actually freedom. More people are freer on this planet than ever before, and as a result, more people are happier. Does this mean that you should quit the job or relationship to which you've become an unhappy slave, buy a boat, and chart your own course to freedom? Only you can answer that.

"Does *Latitude* have a database of DIY (do-it-yourself) boatyards in Mexico?" wonders Peter Hartmann of the Blaine, Washington-based 52-ft DeRidder sloop **Ahaluna**. "If there was such a list, it would be great if there could be ratings by cruisers who have used them."

Unfortunately, we don't have such a list, but we threw Hartmann's question out to the *Electronic* readership. The following are two of the responses, with more to appear in the October issue *Letters*. If you have a DIY yard in Mexico to recommend, we'd love to share your input.

"Last winter Heather Corsaro and I hauled my Cal 36 **Euphrosyne** out at Marina Ixtapa near Zihua," reports David

The North Bay's complete marine service facility:

- Complete chandlery
- 40-ton haulout service
- Engine & drive service
- Trailer boat/outdrive service & repair
- Bottom paint
- Finish paint
- Fiberglass repair
- Marine electrical



**Don't Pass Us By...**

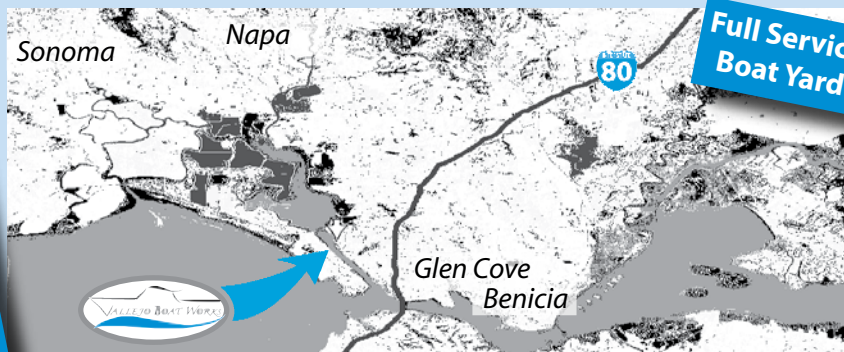

**See us for your service needs on the way up to the Delta!**

Factory Authorized Dealer

"If it's broken, we fix it."



**Why Haul Your Boat Down to the Central Bay?**

**1 Harbor Way, Vallejo**  
(adjacent to the Vallejo Marina)

**(707) 554-2813**

[www.vallejoboatworks.com](http://www.vallejoboatworks.com)



Addleman of Monterey. "It was the most pleasant boatyard experience we've ever had — although the bar is pretty low in that industry, isn't it? Heather and I had earlier bought all the paint and supplies we needed at Zaragosa Marine in Puerto Vallarta. The yard staff at Marina Ixtapa was very professional, their Travelift is large and new, access was easy, and the prices were about the same as in the States. The marina has security, and we were able to stay on the boat. We shared the gravel yard with a few large powerboats. We did all our own work, although there seemed to be plenty of skilled local talent available. Well, actually I did the work while Heather read, flirted with the yard crew, and chilled beers for me. The best part is that the other yard workers shared their lunch with us — ceviche and such made on the spot! One night a foreman took us to his home in Zihuatenejo for showers and a fried fish dinner. He had earlier taken Heather to a local soccer match, where he offered to make her a happy Zihuatenejo fishwife! Another attraction of the yard is that large croco-

diles are common in the marina. Both Heather and I are impatiently waiting for the October 27 start of the Ha-Ha to sail down to Mexico again."

"My boat is currently on the hard at Marina Seca in Guaymas," reports Leonard Bisgrove, who did the '06 Ha-Ha with his San Diego-based Endeavor 40 **Vallee Cachee**.

"I'm having a new aluminum fuel tank fabricated, as well as major fiberglass work done to the hull. When I return to the boat in November, I'll be putting on a new barrier coat, new primer, and new bottom paint, and doing lots of other small jobs. The work that has already been done, has been done well, and at



**With such a big Travel-Lift and so little business, we have to believe that the Fidepaz Yard in La Paz would welcome DIYers.**

a lower price than I would have paid in San Diego. You can live aboard in Marina Seca as you work on your boat for \$5/day for the utilities and wi-fi. The yard fee for my 40-ft boat is \$120/month. The yard has its own lift, and my cost for in and out is \$100 each way. Although the

## Can Your Insurance Company Measure Up?



Policyholder Willow Link and Florida Claims Rep, Salandra Dawson

*"On our way back from Florida to Lake Erie, a sudden 35 knot wind forced us into another boat's anchor flattening our dinghy! This safety item had to be replaced for our trip to continue. Salandra, a BoatU.S. Florida Claims Representative, saw that our check was issued within days and drove her own car to the coast where we were waiting..."*

BoatU.S. has been insuring boats and caring for boat owners for more than 40 years. All policies come complete with unparalleled claims service and peace-of-mind coverage that you won't find with other insurance companies.

*"...BoatU.S. exceeds expectations by demonstrating concern for their customers—truly the measure of a good, trustworthy insurance company."*

— Willow Link, BoatU.S. Insured



All policies are subject to limits and exclusions.

For a fast, free quote, call  
**1-800-283-2883**

priority code 4848

or log-on to **BoatUS.com/insurance**

# CHANGES

amenties at Marina Seca are a bit primitive, the yard has 24-hour guards and is secure. The nearby city of Guaymas has everything anybody would need to do boat repair, and the chandlery in San Carlos can order whatever other marine gear anyone might want from the States."

Folks cruising to Mexico often want to know what kinds of things they should bring as gifts to pass on their way to Cabo as well as elsewhere in Mexico. We put the question to Mary Shroyer who, along with her husband Mac, created Marina de La Paz. Now more than a quarter of a century old, it was one of the first marinas in Mexico.

"My suggestions are school supplies, such as notebooks, pencils, colored markers, colored construction paper, scissors, and so forth. And if somebody has bunches of stuff, they should try to get it to elementary school teachers in Mexico, who often have to buy supplies from their own limited salaries. Folks might try to locate a retiring elementary school teacher in their hometown, as they often have boxes of leftover supplies. Also



LATITUDE/ANNIE

**You can find great gifts for kids in Mexico right on top of your desk. Pens and pencils — with paper — are better than candy.**

good are toothbrushes and sample-size tubes of toothpaste, as well as shampoo and lotion, such as is provided in hotel rooms. Children's shoes, socks, and underwear are always needed. I know that

kids down here love candy, but from an early age they eat too much of it, as well as drink too much soda. By the time first-time cruisers reach La Paz, they will start to get an idea of stuff they brought but wish they hadn't. Fortunately, the **Club Cruceros de La Paz** holds a fundraiser at the end of each November for their charitable foundation, and would be glad to accept anything you want to get off the boat. Another thing many folks have found that makes their cruise more satisfying is joining a 'good works' project in Mexico, such as helping in schools, building shelters, and the like. There will be plenty of opportunities."

"I'm planning to singlehand around Cape Horn in December," reports 62-year-old Jeff Hartjoy of the Longbranch, Washington-based Baba 40 **Sailors' Run**. Earlier in this month's *Changes*, Hartjoy reported on his and his wife Debbie's stop at seldom-visited San Lorenzo, Honduras. Hartjoy mentions that his wife doesn't plan on making the 4,500-mile passage around Cape Horn to Buenos Aires, Argentina, but will work for a few

**MARINA MAZATLÁN:**  
**MÉXICO'S**  
**NEW "HOME PORT"**

MEXICO'S BIGGEST YACHT HARBOR KEEPS GETTING BETTER. THE NEW SINGLAR DOCK YARD FACILITY IS NOW OPEN HERE IN OUR SECURE HARBOR. MAZATLAN OFFERS SUPERIOR MARINE SERVICES, REPAIRS, RESTAURANTS, SUN, FUN, BEACHES... AND A GREAT CRUISING COMMUNITY. MEGA YACHT NEW DOCK 220 V 100 A.

**2008 SUMMER CRUISING RATES:**  
JUNE 1, 2008 OCTOBER 31, 2008.

SIZE OF BOAT	0' TO 41'	42' TO 60'	61' TO 90'	90' OVER	CAT
01 TO 10 DAYS	\$ 0.60	\$ 0.70	\$ 1.00	\$ 1.10	\$ 1.00
11 TO 29 DAYS	\$ 0.45	\$ 0.53	\$ 0.70	\$ 1.00	\$ 0.90
30 TO 90 DAYS	\$ 0.35	\$ 0.42	\$ 0.48	\$ 0.58	\$ 0.58
91 DAYS OR MORE	\$ 0.32	\$ 0.38	\$ 0.45	\$ 0.47	\$ 0.48

RATES, IN U.S. DOLLARS, ARE BASED ON DOCUMENTED LENGTH AND DO NOT INCLUDE 15% TAX. 30 FOOT MINIMUM CHARGE.

**marina mazatlán**

FOR ALL RESERVATIONS, DETAILS AND FURTHER DISCOUNTS  
CONTACT: ELVIRA@MARINA-MAZATLAN.COM  
PHONE: 011-52-669-669-2936  
PHONE & FAX: 011-52-669-669-2937  
WWW.MARINA-MAZATLAN.COM

**MORE FUN. LESS FUEL.**

- Quiet, 4-stroke technology
- Unsurpassed fuel economy
- Transistorized pointless ignition
- Ideal for sailboats, small tenders

**IDEAL FOR SAILBOATS AND SMALL TENDERS**

Meets EPA 2006 & CARB 2008 Emissions Standards!

POWERED BY  
**HONDA MARINE**

© 2008 American Honda Motor Co., Inc.  
Always wear a personal flotation device while boating and read your owner's manual. 5-year warranty standard on all new Honda outboard engines purchased. Check with participating dealers for complete details.

POWERED BY  
**HONDA MARINE**

**DORY**  
POWERED BY HONDA

**BOSTON WHALER**

**Universal**  
DIESEL MARINE ENGINES

**Outboard Motor Shop**  
Where the professionals shop!  
(formerly Seapower Marine)  
**(510) 533-9290**  
www.outboardmotorshop.com  
333 Kennedy St., Oakland, CA 94606 • Fax 510-533-3374



months, then rejoin him in Argentina. The Hartjoys, one of the most energetic cruising couples you'll ever meet, did the Ha-Ha in '99 to start a seven-year, 35,000-mile circle of the Pacific. After coming home for a few months, they took off again as part of the '06 Ha-Ha, and have been out ever since.

Rob and Lorraine Coleman, formerly of the East Bay and more recently of Honolulu, report that they, plus Borau, the boy they sort of 'adopted' from Fanning Island, arrived at Apia, Western Samoa, aboard their gaff-rigged Angleman ketch **Southern Cross**. "It's the first time we've had internet and water to our boat in 18 months," they write. "We're in a small new marina that has electricity and cold water showers. The cruisers here are mostly from Europe, so we're in an international crowd again. Most American cruisers go to Pago Pago, American Samoa, which would have been more convenient, but we just didn't want to go there. Apia is a nice city with most conveniences, and — except for the marina fees — is very affordable. It's not big

or fancy, however, as there are only a few buildings as tall as six stories. The people of Western Samoa are very pleasant and speak both Samoan and English. We haven't been swimming in weeks, and miss our Fanning Island swimming hole. There is a place where we could swim about five minutes from here, but we think you have to wear a clothes or lava lava. The people are very religious, which is why doing anything productive on Sundays is considered disrespectful. We're walking our feet off, usually putting in about four miles a day."

"We did the '08 Puddle Jump, spend-



*The small, but well-built marina at Apia, Western Samoa — which should never be confused with American Samoa, which is very different.*

ing most of our time in the Marquesas," report Ralph and Glenda Johnson of the Corpus Christi, Texas-based Hans Christian 41T **Our Country Home**. "We then continued on to Fakavara in the Tuamotus before heading to Papeete. We're now hauled out, and unless we

## The Simple Choice For Fresh Water

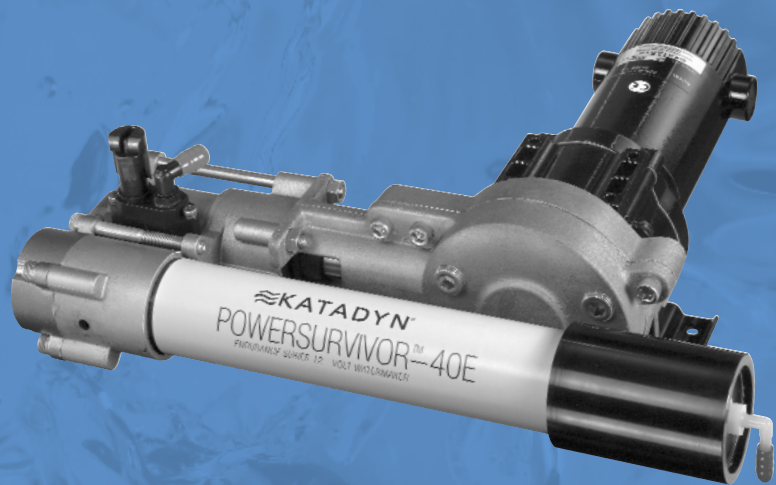

Katadyn PowerSurvivor Watermakers are compact, reliable and easy to maintain. That's why they are the best selling watermakers for cruising sailors.

Making your own fresh drinking water is a great addition for the independent lifestyle. Katadyn watermakers are simple in design, moderately priced and have proven reliability.

Ask your marine outfitter or contact us about a great way to improve life on-board.

800.755.6701 • [www.katadyn.us](http://www.katadyn.us)

**KATADYN**  
MAKING WATER DRINKING WATER

# CHANGES



***It's nice that there's a new fuel tank at Puerto Escondido, Baja, but without fuel, it's not of much benefit to mariners or Fonaport.***

can get a visa extension for next year, will leave the boat out until April '09. We plan to return to the Tuamotus to see more of them, sail around the Societies, then continue farther west."

Yes, we have no fuel. When the Mexican government decided to change the name of their Singlar marinas in the

and some mariners had to pay big bucks to have it delivered from 30-mile distant Puerto Escondido.

It's been a pretty busy **hurricane season in the Eastern Pacific** — meaning the Pacific Coast of Mexico — so far. Between the official start of the season on June 1 and August 17, there had already been five tropical storms and five hur-

ricanes. So how come you haven't heard about any of them? Because like most Eastern Pacific tropical storms and hurricanes, they've moved off to the north and west, and therefore out to open waters. Secondly, none of them have been particularly powerful hurricanes. But since the season doesn't officially end until November 1 — and for some people not until November 15 or even December 1 — we're not out of the woods yet. In fact, September has historically been the most dangerous month, so let's be prepared and keep our fingers crossed.

While no tropical storms or hurricanes have hit land in Mexico this season, they've nonetheless made life miserable because they push lots of moist air north, jacking up the already high humidity. So from Puerto Vallarta to La Paz, the complaint has not been about the high temperatures, which are normal, but the humidity, which has been much higher more often than in previous years. It even rained four out of 10 days in La Paz in August, which should make for a greener than normal winter on the islands.

## The Choice is Clear



### THE SAILBOAT PROPELLER FROM **FLEX-O-FOLD**

- Unmatched powering performance
- Superior performance in reverse
- Lowest drag under sail
- Robust construction
- Virtually no maintenance
- No fouling of lines under sail
- 2 and 3-blade, saildrive and standard shaft
- Patented twin-helical gear design for reliability
- Patented locking screws
- Reasonable cost

Contact us for more information.

91 Front Street Marblehead, MA 01945  
Tel: 781-631-3190 Fax: 781-639-2503  
e-mail: [amsales@flexofold.com](mailto:amsales@flexofold.com)

**FLEX-O-FOLD**  
**PROPELLERS**

## KISSINGER CANVAS

Marine Canvas & Interiors  
STEVEN KISSINGER

**(925) 825-6734**

Covering the Entire Bay Area



- Biminis
- Boat Covers
- Cushions
- Sail Covers
- Headliners
- Awnings

### DODGERS

Side handrails and window covers included.

#### OPTIONS

Aft handrail, dodger cover, sailing bimini.

*Free Estimates and Delivery*





# MARINA RIVIERA NAYARIT

AT LA CRUZ

the ultimate ... *Marina Experience*

Ask about our  
Winter Events & Specials!

Marina Coordinates: Latitude 20°45'N, Longitude 105°24'W



Full Service Marina with up to 400 Vessel Capacity (30-400 ft.),  
Fuel Station, Pump Out, Dry Dock, 150-ton Travel Lift, Yacht Club, Water,  
Power, WiFi, Restrooms, Showers, Palapa Restaurant and Sky Bar.  
And Coming Soon: Hotel Site, Condominiums, Shops,  
First-Class Services and Much More!



La Cruz de Huanacaxtle, Bahía de Banderas, Nayarit, México • Tel (011 52) 329 295 5526  
info@marinarivieranayarit.com • www.marinarivieranayarit.com



Please read before submitting ad

# CLASSIFIEDS

**1. Write your ad.** Describe what you're selling. Indicate category. Don't forget price and contact info. Be neat. We aren't responsible for errors due to illegible writing or unclear meaning. We make final placement determination.

**2. Count the words.** Anything with a space before and after counts as one word (eg, phone number, email address, price). We'll spell-check, edit and abbreviate, as necessary.

**3. Mail your ad.** Enclose check or money order, or deliver to our office with cash, or ...

Post your ad safely online with Visa, MasterCard or AmEx at: [www.latitude38.com](http://www.latitude38.com)

## Personal Ads

1-40 Words: \$40  
41-80 Words: \$65  
81-120 Words: \$90  
Photo \$30

• Personal Advertising Only •  
No business or promo ads except Non-Profit, Job Op, Business Op

## Business Ads

\$70 for 40 Words Max  
• All promotional advertising •  
1 boat per broker per issue  
Camera-ready art OK  
No photos or reversals  
No Extra Bold type  
Not to exceed 12 pt font  
Artwork subject to editor approval.

### 'Trying to Locate' Ads

Searching for People: \$10 for 20 Words Max

All ads will be set to fit *Latitude 38* standard.  
Re-Run Ads: Same price, Same deadline.

Mail (or bring) to:

*Latitude 38*  
Attn: Classified Dept

15 Locust Ave, Mill Valley, CA 94941

Questions?: (415) 383-8200, ext 104 • [class@latitude38.com](mailto:class@latitude38.com)

## DEADLINE

is always the

**18th at 5 pm**

of the month prior to publication.

Due to our short lead time, deadlines are *very strict* and include weekends & holidays.

- No ads without payments
- No billing arrangements
- No ads accepted by phone or fax
- No verification of receipt
- We reserve the right to refuse poor quality photos or illegible ads.

## DINGHIES, LIFERAFTS AND ROWBOATS

**PHIL BOLGER-DESIGNED 15-FT** Peapod rowing dory. Boat is in excellent condition and handles two adults comfortably. \$900 includes oars, new canvas cover and older but serviceable trailer. Please call (707) 265-8415 or email: [rdoormann@vom.com](mailto:rdoormann@vom.com).

**BYTE DINGHIES.** Smaller version of a Laser. Start your own family race team. \$3,800 takes all. (925) 285-0351.

**CLASSIC AEOLIUS/GRUENWALD** 18-ft dory. Completely overhauled with new seats, new oars, new full canvas cover, new Honda motor, new motor well and new trailer. Rows beautifully but can be motored when needed. \$3,500. Call (707) 265-8415 or [rdoormann@vom.com](mailto:rdoormann@vom.com).

**ROCKY BEACH LANDING PROBLEMS** begone. 2002 Aquapro 11' aluminum bottom inflatable with wheels, cover, oars plus Yamaha 15-hp 4-stroke outboard will change your cruising world. Plane you and provisions back to the hook and prime spots nearby. \$3,200. Alameda. Email: [currie@onourboat.com](mailto:currie@onourboat.com).

## 24 FEET & UNDER

**SANTANA 20, 1979.** Freshwater boat currently on trailer. Main, 2 jibs, spinnaker, all in good condition. Possible trade for trailerable boat with retractable keel. Please call for information. \$3,400/obo. (209) 768-1880.

**FREEDOM 21.** Free-standing carbon mast, full-batten main, as-new jib, spinnaker with gunmount pole. 4-hp outboard. Located in Alameda. Very easy to sail, great for beginners. Low maintenance. \$2,800. Call (510) 864-0237 or email: [borelmgf@earthlink.net](mailto:borelmgf@earthlink.net).

**COMPAC 16, 1989.** Main, jib, genoa, trailer, 4-hp Johnson 2-stroke. All in good shape. Great trailer sailer. \$3,200/firm. Call (916) 730-8227.

**1984 ALCORT FORCE 5 SAILBOAT** and trailer. Both registered. Located in Rio Vista. \$800. Sail ready. (707) 374-6353.

**RANGER 23. \$1,350 FOR FAST SALE.** Good sails: main, 4 jibs, spinnaker. Spinnaker and whisker poles, battery operated lights. Anchor, 150' rode. Good V-berth cushions, Porta-Potti, inflatable dinghy. Strong Nissan 5B outboard. Paradise Cay Marina. Call John (415) 258-9289.



**GLADIATOR 24.** Full-keel sloop rigged for singlehanded cruising. Dodger, Navik windvane, 85w solar panel, mast steps, 2 anchors, GPS, Raymarine wind, depth, speed, tiller/pilot. 8 sails including cruising spinnaker with ATN snuffer. Outboard bracket, no motor. \$7,950. Call (916) 481-3199.

**22-FT POCKET ROCKET.** Gary Mull design. Trailer, Ballenger mast, new rudder, depthsounder, VHF, autopilot. \$7,500. (408) 245-1387.

**COLUMBIA 22, 1972.** Ideal first boat, simple and fun. \$3k in upgrades: sails, rigging, 4-hp outboard, cushions, marine head, solar panel, Life Sling, and more. Alameda upwind berth available. Have too many boats, must sell, make reasonable offer. John (510) 604-6518.

## 25 TO 28 FEET

**TANZER 7.5.** Strong, well-designed Canadian sailboat with a great owners group. Shallow draft. Johnson 6 hp. Several sails in good shape. On two-axle trailer at Alameda Marina. Space transferable. Easy to launch from here. \$4,000. Pablo (510) 220-2413.

**BRISTOL 27, 1978.** Classic cruising yacht. Great condition. Atomic 4 inboard gasoline engine runs well. Very clean, recently refinished wood, new batteries, modern charger. Full setup, foulies, extra gear. Berkeley slip. New baby doesn't sail (yet!). \$12,900. [rob@robconant.com](mailto:rob@robconant.com) or (510) 334-1135.

**CLASSIC PEARSONTRITON 28.5, 1962.** Ready to sail. Sturdy for offshore and Bay. 18-hp freshwater-cooled Yanmar diesel. 7 sails including spinnaker. Barient, autopilot, standing headroom. Haulout 4/05. Located Redwood City, CA. \$8,500. Certified check only. (650) 327-0190. Can email photos.

**J/80, 1993. HULL #45.** No trailer. Sausalito berth. Light, fast and fun. Epoxy-faired bottom and foils. 2007 Doyle V/C Stratis main and jib. 2 spins. Email for details. \$33,000. Peter (415) 847-0220 (cell) or [peter@stdesigninc.com](mailto:peter@stdesigninc.com).

**CATALINA 27, 1972. LUCKY DUCK.** New in 2007: standing rigging, bottom, mainsail, much more. All lines led aft, easy to sail. Dinette/outboard model, no outboard included. Oyster Point berth. \$3,500/obo. Call Fred (415) 425-0805.



**HUNTER 28 SLOOP, 1991.** Great condition. Good first Bay/Delta boat. 30 gallon water, new holding tank and Raritan head, Yanmar diesel, tridata, VHF, Edson wheel, 110 AC and battery charger, shower plus transom shower, large bimini, 3 headsails, new bottom paint and cutlass bearing in Jan, lazyjacks and Magma BBQ. \$27,500. Email: [serenisea@comcast.net](mailto:serenisea@comcast.net).

**SANTANA 525 WITH TRAILER.** 6 sails, speed and depth. New running rigging, standing rigging, interior paint, woodwork, safety package, VHF, depthsounder, battery, solar charger, new brakes and tires on trailer. Also includes custom mast raising/lowering system. \$6,500/obo. Will deliver Seattle to Southern California. (541) 601-1948 or [garyg@ko-ching.com](mailto:garyg@ko-ching.com).



### Beautiful Cedar-Strip Row Boat

15'4" x 4'6" • Two fixed-seat rowing stations  
Light and fast • \$6,800

John Tuma Boat Builder • (510) 366-1476

### CHART SAVINGS UP TO 75%

#### HIGH DEFINITION PRINTS • 256 INCREDIBLE SHADES!

Worldwide • Sample Chart \$7.95 • Affordable E-Chart back-ups  
Bellingham Chart Printers Division, TIDES END LTD., PO Box 397L, Shaw Island, WA 98286  
800-643-3900 • fax: 360-468-3939 • [www.tidesend.com](http://www.tidesend.com) • [sales@tidesend.com](mailto:sales@tidesend.com)

### MARINE ENGINE CO.

Complete Engine Services • Gas & Diesel  
30 Years Experience • Reasonable Rates  
Tune-Ups • Oil Changes • Engine Rebuilding, etc.  
(415) 332-0455



### STARBOARD YACHT DELIVERIES

Over 50,000 sea miles • Pacific, Caribbean, Atlantic  
USCG Master 100 GT STCW • Power & Sail

Rick Whiting • (415) 740-2924 • [captain\\_rick@sbcglobal.net](mailto:captain_rick@sbcglobal.net)



**BRAND NEW 2008 MacGREGOR 26M** powersailer sailboat, fully loaded. Includes 2008 Evinrude 60-hp E-Tec engine with less than 10 hours use. Sails and powers excellent. License fees already paid. Trailer and/or sail immediately. \$36,900. Email: angelbocanegra2006@yahoo.com or call (925) 513-8729.



**CAL 25. SOLID BAY CRUISER.** Well kept, standing headroom, two-burner propane stove, new safety equipment, lots of extras. All lines aft, heavy rigging, 9.9 Honda. Roller furling. Asking \$7,500/obo. (209) 986-4451.

**CATALINA 27, 1981.** Universal Atomic diesel, Harken furling, new headsail and storm jib, standard rigging, fold-down table model, good clean condition. Rio Vista. \$5,500. Call (916) 448-2644 or email: John@Fredenburg.com.



**MacGREGOR 26, 1993.** Not motorsailer. Water ballast, swing keel. Sails, genoa, sail covers, bags. Cockpit cushions, pop-top enclosure. Mast-raising system. Yamaha 9.9, electric start, 4 stroke. Trailer with new tires. Excellent condition. \$6,500. Call Roger (916) 663-1950.

**NEWPORT 28, 1979/80.** Anchorage included. \$3,500. 11-hp Universal, roller furling, VHF, stereo, new 135% genoa. Head with holding tank, sink, stove, shower, sleeps 5, 6'1" headroom. Photos available. Health problem forces sale. Call (415) 621-2190 (lv msg).



**CATALINA 25, 1986.** Pop-top, 9.9-hp Johnson outboard with electric start. Clean and ready to go. Reduced to \$6,500/obo. In the Delta. More pictures at: <www.deltadrifter.com> (916) 777-5510.

**CATALINA 27, 1976.** Atomic 4, runs great, sails good condition, spinnaker pole, BBQ. New since 2007: Bottom paint, seacocks, LPG stove/locker, stereo, storm jib, head/holding tank, traveler, mainsheet blocks, engine blower, battery, fire extinguishers, grabrails with covers. Great starter boat for Bay. \$6,000/obo. Alan (650) 996-6309.

**LASER 28, 1985.** Bruce Farr design. Spacious interior. All Kevlar construction. Diesel inboard. Bottom job needs to be finished. Good and complete set of sails. Stored on yard trailer at Alameda Marina. \$14,000/obo. Call Tom (510) 865-6641.



**CATALINA 25, 1981** fixed keel with trailer. Mercury SailPower, IdaSailor rudder. New complete bottom, entire electrical/plumbing new. 7 lines aft, lots of ground tackle. Setup to cruise/live. Way more info. \$11,500/offer. (209) 559-3753.

**YAMAHA 26, 1989.** Yanmar diesel in excellent condition, roller furling, dodger, windvane, autopilot, solar panel, inverter, GPS VHF, AM/FM/CD, Bruce and Danforth anchors, liferaft. \$16,000. Call Mic (650) 728-5945 or email: nagayoshi@netzero.net.



**FREE TO GOOD HOME:** Classic wooden 'Neptune Cruiser'. Swedish racing sloop and trailer. Workshop where would have been restored gone to development. Re-fastened, new sails never out of the bag. Very similar to Knarr. (510) 390-2960 or cgnicholas@alamedanet.net.



**J/27, 1986, #134.** Superb performance boat for club racing and daysailing. Excellent condition. Balanced, nimble, points high, PHRF 123. Lots of sails and more. \$17,500 as is, where is. Specs/photos: (415) 456-2397 or email: portobello40@earthlink.net.



**YAMAHA 25, 1978.** Excellent condition. New standing and running rigging, four new Hogin sails, dodger, YSMR vane, solar panel, sumner, all accessories, all alcohol, room, can't keep her, boat to go cruising. \$8,000/obo. Located in Alameda. (510) 610-1010.

**ERICSON 25, 1973.** Keel/centerboard model. Excellent condition with two-axle trailer, mainsail plus two headsails, 9.9-hp electric-start outboard. Danforth-type anchor with chain and rode, stove, VHF, depthsounder, stereo, enclosed head with holding tank, sail covers, 5'8" headroom. Mainsail is old but serviceable and both headsails are in good condition. Trailer has surge brakes but has been sitting in yard for last few years and probably needs TLC. \$4,000. Please call (707) 265-8415 or rdormann@vom.com.

**29 TO 31 FEET**

**COLUMBIA 30.** 6 headsails and spinnaker, 2 mains, dodger, autopilot, 4-cylinder gas, Martec prop. \$6,500 or trade for a 20 to 26-footer with trailer. Retired to the mountains. Fortman Marina, #G-22, Alameda. Call (559) 642-4896 or email: geezer@sti.net.

**1988 BUEHLER.** Port Orford cedar coastal sailboat. LOD 30', LOA 38', aluminum mast, 40-hp Westerbeke, wood heat stove. Liveaboard mooring available until July 2009, then renegotiate with commercial harbor, Brookings, OR. \$40,000. Call (360) 450-3749 or email: kijicoln8@yahoo.com.

**BUCCANEER 28.5 SLOOP.** Trailer, center cockpit, wheel, positive flotation, diesel, Autohelm, depth gauge, GPS, roller reefing genoa, solar, swim platform, 6'2" headroom. 10'Avon with 3.3-hp Mercury ob. This is a fully equipped cruiser. Pictures and specs: <www.rhmarx.com> \$27,500. (928) 684-9606.

**CATALINA 30 SLOOP, 1981.** Original owner, clean interior, new main and 90% jib. 24-hp Yanmar 3GM30F. Fresh bottom. Wheel steering, standing rig replaced 2001, dark brown trim. Located South Beach Harbor, SF. \$18,000. (415) 731-4956.



**WOODRUM MARINE**  
Specializing in custom interior cabinetry, tables, cabinets, countertops, cabinsoles. For power or sail.

**ISLANDER 30, 1980. \$29,950.** Aries windvane, watermaker, dinghy, 555, CQR, inverter, ICOM 706SSB, Pactor, refrigeration, EPIRB, solar, Autohelm, 2 GPSs, plotter, VHF, spinnaker, more. Islander alone \$24,500. Pictures and prices on individual gear. Email: guyandsusie@sbcglobal.net or call (650) 591-3791.

**NEWPORT 30 Mk II, 1987.** ASMO electric drive just installed. 110v charger/inverter. Just hauled. Raymarine radar, chartplotter, autopilot. DSC/VHF. Full galley. Dodger. Air Head composting head. Cabin heater. More. \$16,800/offer. Rich (661) 829-1570 or kq6ef@pacbell.net for info.

**1978 ERICSON IN GREAT CONDITION.** Yanmar diesel, wheel steering, new canvas and upholstery and running rigging, GPS, refrigeration, new cook top and VHF radio. \$23,000/obo. Call (831) 419-2083.



**TASHIBA 31, 1987.** Do you want to join the Baja Ha-Ha or Puddle Jump this year? This Bob Perry-designed, Ta Shing-built bluewater cruiser is ready to go. *Felicity* is in excellent condition, complete refit with top-of-the-line equipment in 2000, meticulously maintained since. Systems and gear you'd expect to find on a 40+ foot boat including: watermaker, weatherfax, SSB, autopilot, Monitor windvane, radar, full set storm sails, asymmetrical spinnaker, Adler Barbour refrigeration, Espar forced-air diesel heater, Grohe galley sink, double stainless sinks, custom v-berth mattress, ultrasuede upholstery, dodger, bimini, custom full boat cover, plus much more. \$125,000. Full specs and photos see: <http://www.svfelicity.com/sale> or call (425) 869-6266.

**CATALINA 30, 1978.** Hybrid conversion in progress. 15-hp outboard for backup. Equivalent 21-hp electric motor and batteries, mounting in progress. Solar panel. Needs inverter, etc. Can finish professional installation. Clean boat. \$14,000/obo. (415) 606-2019 or (415) 258-5709.

**PACIFIC SEACRAFT MARIAH, 1979.** LOA 36', LOD 31', LWL 25', beam 10'9", draft 4'5", displacement 16,000 lbs, ballast 6,000 lbs. SA 596 sq ft, headroom 6'5". Fiberglass hull double-ender, full keel, cutaway forefoot. Wheel steering or emergency tiller. Staysail, roller furling foresail, fully battened mainsail. 30-hp Yanmar diesel, full service 12/07. Survey 12/07. New standing rigging 9/03. Bottom paint 4/07. Radar, GPS, VHF, SSB/Ham, Muir windlass, more. Clipper Marina, Sausalito. \$69,000/obo. Richard (415) 927-2765.

**WISE MARINE SERVICES**

Refrigeration • Air Conditioning • Electrical • Engine Services  
Experienced in both Power and Sail systems  
**Roger Wise • (510) 418-7550 • rdwisesr@gmail.com**

**BOAT • LETTERING**

alphaboatsue@aol.com • (510) 599-1197 • www.alphaboatgraphics.com  
**Creative and durable lettering and artwork for your boat**

**SMALL AD, SMALL PRICES • RIGGING ONLY**

Standing and running rigging, life lines, furling gear, winches, line, windlasses, travelers, wire and terminals, blocks, vang, and much more.  
~ ~ ~ *Problem solving and discount mail order are our specialties* ~ ~ ~  
**www.riggingonly.com • (508) 992-0434 • email: sail@riggingonly.com**

## Custom Canvas & Interiors



The Gianola Family has been designing and fabricating custom canvas and interiors since 1969. Gianola & Sons offers you the best in quality, more choices, and personal service.



360 Gate 5 Road  
Sausalito, CA 94965  
(415) 332-3339  
www.gianolacanvas.com

## Ryan's Marine

Specializing in Marine Electrical Services  
for Your Boat

- Electrical system installations from inverters to electronics packages
- Troubleshooting of existing systems
- Dealer for the complete Balmar product line
- Head and holding tank installations



**(510) 385-3842**

Ryan Schofield  
Owner since 1997

email:  
rssailor@yahoo.com

## MARINE ENGINE CO.

PERKINS • YANMAR • ATOMIC 4 • VOLVO  
WESTERBEKE • UNIVERSAL • BETA MARINE

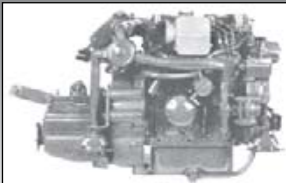

### CALL NOW FOR LOW ENGINE QUOTES

- Engine Repowering and Rebuilding
- Engine Sales, Service and Parts
- Complete Marine Engine Service

**(415) 332-0455**

**CATALINA 30, 1979.** 2 jibs, main. Atomic 4 30-hp engine. New mast and rigging 12/07. \$12,000. Recent survey available. Moss Landing Harbor. Call (831) 239-1395 or yolandagp2000@yahoo.com.

**TARTAN 30, 1978.** Great Sparkman & Stephens design with skeg-mounted rudder and mast stepped to keel. Dodger, furler, 6 sails, spinnaker pole, 2 anchors, recently replaced standing and running rigging. Turnkey condition. Atomic 4 engine runs great. New stainless fuel tank, Adler-Barbour refrigeration, new Kenyon stove, new head, many extras. Located at Marina Village Yacht Harbor. \$19,500. Call (510) 864-9880 or ejwoollett@aol.com.

**ERICSON 30, 1968.** Vallejo. Sloop, sleeps 6, diesel, full galley, head with holding tank, furling jib, tiller steering, pressurized cold water, refrigerated icebox, good live-aboard. Great family boat. \$9,000. (916) 655-3058 or tralphkays@yahoo.com.

**OLSON 30, 1980.** Double-spreader Ballenger mast and boom, Harken and Lewmar deck hardware, very nice Lewmar forehatch for bow spinnaker launch. 9 bags of sails plus 2 spinnakers. Trailer. Santa Cruz dryslip sublet available. Must sell. \$10,000. (831) 475-5256 (lv msg).

### 32 TO 35 FEET

**RANGER 33, 1978.** Wheel steering, Universal 16 diesel, dodger, Monitor windvane, Pineapple sails with extras including storm jib. New bottom, alcohol stove, Raritan head. Ready to cruise, race, liveaboard. Located La Paz, Baja. \$24,600. (415) 902-1061.

**WE HAVE A VERY CLEAN EXAMPLE** of the Cheoy Lee Lion for sale. We are seeking her new sailing companion due to a larger boat purchase. Asking \$35,000/obo. Please email or call for a complete equipment list: (707) 688-2314 or webmaster@deltamarina.com.



**J/BOATS J/100, 2005.** Fast, fun, ultimate singlehander. Extensively equipped: jib boom, lifelines, dodger, lazyjacks, B&G autopilot and instruments, Furuno GPS, VHF with RAM, new gennaker and new 3DL class jib (winter 2008), powered halyard winch, solar charger, two sets of primary winches, whisker pole, Bottomsiders cushions. Wow. \$129,000. Contact Steve for more information: (415) 931-7983 or SteveR.sf@gmail.com.

**OFFSHORE ONE DESIGN 34, 1980.** Doug Peterson design, Jeremy Rodgers construction. Excellent condition. Carefully maintained and improved with many recent upgrades. Exceptional value at \$39,000. Call (415) 388-2582 or (415) 552-0860 for more info. Photos and details at: <http://yacht.milagro.googlepages.com/home>

**1986 HANS CHRISTIAN 33 CUTTER.** Original owner, good to excellent condition, new bottom 10/07, 80-gal fuel, 90-gal water, Kenyon tapered spars, Navtec backstay adjuster, all rigging and winches oversized, Sea Tiger windlass, 1 Bruce and 1 CQR with 75' chain/rode. Seaward stove/oven/heater LPG, Cool Mate refrigerator, microwave, Yanmar 3QM30 freshwater cooling, Icom IC-725 SSB, weather fax, Icom IC-M55 VHF, Autohelm 7000, Raytheon R20 radar, Raynav-570 Loran, Si-Tex A310 satellite navigator, Harken Mk III jib furling, new Sutter sails 2003, 3/4-oz. reacher drifter, 1/2-oz. spinnaker with 4" pole and rigging, 130 genoa, 75-amp alternator, True Charge battery charger, 2 battery banks, Sony stereo/CD player, 2-man raft, more. \$100,000/obo. Located Lake Tahoe, CA. (775) 287-9360 (days) or (775) 852-0321 (eves) or kathi.kunze@gmail.com.



**J/105, 2002, SAIL #497.** Stars & Stripes Blue hull, B&G instruments, autopilot, Furuno GPS, GoriProp, Sony stereo. Shorthanded set-up. Antal cars on trac with lazyjacks. All can be removed for one-design racing. Good sail inventory. Very light use. \$124,000/obo. John (415) 332-6395.

**PEARSON 32 RACER/CRUISER, 1979.** Not the 323. Fast, easily singlehanded. Featured in August 2007 *Practical Sailor*. Original M-15 Universal diesel, 1,250 hours. Gear (vintage 1995): Autopilot, digital depthfinder and gauge, gennaker, Harken furler, Navtek backstay adjuster, Hall Spars Quik Vang, Furuno radar, 25w marine radio. New: 19-gal aluminum fuel tank and electric fuel pump, 2002. Documentation: All original manuals, surveys, maintenance, diving, haul records since my 1995 purchase. Location: Alameda. \$23,000/obo above BUC 'Fair'. (510) 525-2754.

**COLUMBIA 10.7M, 1980.** 35', recently serviced 22-hp Yanmar diesel, good main and jib, extra gear and sails, dodger, bimini, radar, shower, large interior, good condition, everything works, dry sailer. Brickyard berth. \$39,000. Call Dan (530) 753-0270 (eves).

### NORTHWEST CLASSIC 33, 1981

Scott Spague vet • Ready to go again • \$108,000  
Visit: <www.wallaceyachts.com>

**(360) 774-2721 • markus@wallaceyachts.com**

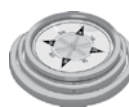

### NOR-CAL COMPASS ADJUSTING

Magneuto™ System Exclusively  
Boat Remains in Berth • Eliminates Deviation  
Authorized Compass Repair • All Major Brands  
Hal McCormack • Phone/Fax: (415) 892-7177



**DISCOVERY 32, 1969. FLIP.** Built in Hayward by Nor-Cal Yachts. Fin keel, Yanmar 24-hp diesel, new 1997. Berkeley berth steps from BYC. Surveyed by Minkwitz. Photos at <<http://tinyurl.com/66xnjx>> Simple, solid Bay cruiser. Bargain at \$8,500. All proceeds support the Pegasus Project, a 501(c)3. <<http://pegasusvoyages.org/>> (510) 526-2346.

**RON HOLLAND DESIGN OMEGA 34.** Fractional rig sloop. Fast sailing, easily singlehanded, Swedish-built Atlantic veteran. Teak interior, North Sails main, self-tacking jib, 150% genoa. Yanmar 2GM, Lewmar 44STs, windlass, electric head, instruments. See pics: <<http://picasaweb.google.com/omega34sailing>> Lying San Diego. \$35,000. Email: [omega34sailing@gmail.com](mailto:omega34sailing@gmail.com).



**DOWNEAST 32 CUTTER, 1979.** Nice condition. 24-hp Universal diesel, furling jib, bimini, davits, radar, refrigeration, autopilot, solar. New running and standing rigging. Hardshell dinghy, older Achilles inflatable, 3-hp Evinrude. Lying La Paz. \$31,000. (949) 500-0652 or [dgoverman@aol.com](mailto:dgoverman@aol.com).

**C&C 33, 1976.** Navtec rod rigging, Harken roller furling, Harken traveler, Lewmar opening portlights all replaced 1999. Autohelm ST4000 autopilot. Edson wheel. Atomic 4, new exhaust. DSC VHF, GPS, integrated knot and wind instruments. 15 sails. 11 winches, large 2-speed self-tailing primaries, 4 other 2-speeds. Quick-Vang. Topsides paint needs cosmetic help, otherwise in great shape. \$20-25k value. Priced to sell fast at \$15,000. Lots of info at: <<http://www.geocities.com/lfde@pacbell.net>> including 30+ photos, full list of equipment, reviews. Call (650) 325-4773.

**NOR'WEST 33.** Classic bluewater racer/cruiser featured in November, 2006 *Cruising World Classic Plastics*. 1978, hull #6. Cruising ready. Full complement of sails, wind generator, solar panel, new bimini and interior upholstery, radar, GPS, Monitor self-steering vane, autopilot, new standing rigging and Harken Mk IV roller furler at headsail. LectraSan waste treatment system, all new head plumbing, bottom paint, new multi-stage battery charger. Most systems replaced in past 10 years. 2006 survey available. Currently berthed in San Diego. Asking \$55,000. Call (510) 301-3431 or email: [sailskye@pocketmail.com](mailto:sailskye@pocketmail.com).



**HOBIE 33, RETRACTABLE KEEL.** Lake Tahoe entire life. New furling jib. Two-year-old main. Many other sails. Includes trailer. \$20,000. Ted (775) 787-7167 or [stoeve@earthlink.net](mailto:stoeve@earthlink.net).



**HUNTER 33, 2004.** Excellent condition. Glen Henderson design. Absolutely the most custom, cruise-ready 33 on the planet. All top-quality hardware and installation. Too many options, custom products and systems to list. Handles easily and is very spacious and comfortable. Located in Puerto Escondido, Baja, Mexico (no tax delivery). On private anchor system in harbor at \$30/month rent. Will deliver to US location. Divorce forces sale. \$112,500, reduced to \$88,765. (415) 992-8057 or <[www.myspace.com/carlosmango](http://www.myspace.com/carlosmango)>

**BENETEAU 10R, 2007.** Yanmar 20 hp, Harken furler, main, 3 jibs, 2 spinnakers, dodger, canvas, performance and comfort pacs, liferaft storage, multiple NKE electronics and repeaters, loaded, ready to go. \$140,000. Long Beach, CA. Pictures: <[www.quivercharters.com](http://www.quivercharters.com)> Call (310) 809-2263 or [ddavies@usc.edu](mailto:ddavies@usc.edu).

## 36 TO 39 FEET

**EXPRESS 37 Mk II, 1988.** Sleek ocean racer/cruiser. In San Diego. Set up for shorthanded sailing. Spinnakers, carbon fiber rudder, roller furling, radar, windvane, ORC raft, EPIRB, windlass, bimini, SSB. \$76,500. (858) 335-3182. Email for pics/survey: [stv-48@hotmail.com](mailto:stv-48@hotmail.com).



**FAST PASSAGE 39.** Legendary cruising cutter. Two-time Hawaii, three-time Mexico vet. New engine, prop, dinghy, dodger, gennaker. Much much more. \$125,000. For details, email: [DRJY2K@aol.com](mailto:DRJY2K@aol.com).

**36-FT LAPWORTH L-36.** Gray Marine four, folding prop, runs great. 2 sets of sails plus spinnaker, fresh mast plus some new rigging, some assembly required. Needs some rib repair and usual TLC. First \$5,000 takes. (530) 265-2830, maybe (530) 798-9645.

**HUNTER LEGEND 37.5, 1992.** Cruiser-ready sailboat in San Carlos, Sonora, Mexico. Upgraded Autohelm 4000 autopilot, VHF, SSB with DSP filter speaker, Raytheon radar, EPIRB, Raymarine GPS, solar panels, PUR 80 watermaker, Adler Barbour supercold freezer/fridge. Spinnaker, twin headsails, genoa, Portabote dinghy with 6 hp, liferaft, and more. Upgraded standing rigging and added mast steps in 2004. Better than excellent survey of 2005 available. \$84,500. (650) 743-0870 or email: [anitaron@libertycall2.com](mailto:anitaron@libertycall2.com) for pics and more info.



**ISLANDER 36, 1974.** Many upgrades including new bimini, mainsail, stainless port lights and electrical upgrade. Still needs some TLC. \$23,000. (408) 348-3681.

**CUSTOM 38-FT CUTTER.** Built and raced in the 1976 Ostar by legendary sailor Val Howells. Exceptionally strong and well equipped. Rounded Cape Horn twice and well-equipped to circumnavigate again. Berthed in San Francisco, more info at: <[www.bermuda40.net](http://www.bermuda40.net)> \$65,000. (408) 218-9604 or [kabaii@yahoo.com](mailto:kabaii@yahoo.com).



**UNION 36, 1985.** Cruise ready sailboat, asking \$90,000. Survey replacement value 200k. Just returned from 6 years of cruising Mexico. The boat has extensive cruising equipment and spares and has been kept in excellent condition by meticulous owners. Nearly-new Raymarine radar and GPS. She is ready to go back to Mexico and beyond. Just bring your clothes and food and you too can enjoy the dream of cruising. [Jimjaneffleming@yahoo.com](mailto:Jimjaneffleming@yahoo.com).

**CAL 39, 1978. SAME OWNER FOR 16 years.** Many upgrades, including rebuilt Perkins 4-108 engine and transmission, new tapered double-spreader mast, aluminum toerails, radar, electric windlass, below-deck autopilot, headliner, portlights and watermaker. Hard dodger and bimini with new canvas, cockpit screens and solar panels. Updated galley with new, deep double stainless steel sink, refrigeration, propane stove/oven and microwave. New bottom paint 7/08. Much more. \$69,000/obo. (209) 327-0274.

**ISLANDER 36, 1977.** Perkins 4-108, new rigging 2002, 2 self-tailing Harken 44s, 2 self-tailing Barlow 25s. Dodger, covers, holding tank, macerator, propane stove/oven, radar, chartplotter, VHF, bowroller, 2 anchors/chain and rode, carpets/curtains, Avon/ob. Alameda Marina #204. \$55,000/obo. Arnie (415) 999-6751 (cell) or (415) 383-9180 (hm) or email: [arnoldgallegos@comcast.net](mailto:arnoldgallegos@comcast.net).

**BENETEAU 37, 1985.** I am the original and only owner. Immaculate condition. 50-hp Perkins diesel. Rerigged. New sails, new dodger, new sail cover, new head. Excellent sailing. This boat must be seen. \$63,000. Sandy (925) 785-2170.

**ISLANDER 36, CYGNET.** Hull #495, built 1978. An opportunity to own one of the nicest I36s on the Bay. Original owners. Never raced. Beautiful condition, always well maintained. Many extras. A special boat. \$55,000/obo. Please call (415) 601-9457.



**FREYA 39, 1978.** Well maintained and cared for. Current systems and upgrades. Ready for cruising. Specs and photos available upon request via email. Located in San Rafael, CA. \$80,000/obo. (415) 717-5815 or [jellykell@hotmail.com](mailto:jellykell@hotmail.com).

**CATALINA 36, 1986.** Radar, below-deck autopilot, electric windlass, 4# anchor and all chain, refrigeration, propane oven/stove/BBQ, high-output alternator, inverter, dodger, bimini, more. \$55,000. (510) 219-9116.

**ISLANDER 36, 1980.** Yanmar diesel, wheel steering, lots of equipment. Baja Ha-Ha vet. Good condition. Priced for quick sale. Berthed in Berkeley Marina, D4. \$37,000. Mike (510) 644-1217.



**HANS CHRISTIAN 38T TELSTAR.** Well-equipped, classic, bluewater cruiser. Cutter with cut-away keel and skeg. Loves the SF Bay wind. Desirable, upwind slip available in Berkeley. Excellent condition with lots of extras. \$162,800. Email: [sv.mahayana@gmail.com](mailto:sv.mahayana@gmail.com) for information and photos.

Yacht Repair  
Design / Consulting  
Custom Interiors  
Exterior Joinery



## STEVE'S MARINE WOODWORK

60 C Libertyship Way, Sausalito  
[jonessail@aol.com](mailto:jonessail@aol.com) • (415) 332-2500



**WINCHMATE**  
SELF-TAILING CONVERSION

[www.winchmate.com](http://www.winchmate.com)

For Barient & Barlow #27 - #32

(415) 460-5151



Learning to sail is a breeze with the  
**SailingWindWheel**  
[www.sailingwindwheel.com/disc.html](http://www.sailingwindwheel.com/disc.html)

10%  
discount  
to  
Latitude 38  
readers

## PROFESSIONAL YACHT DELIVERIES

60 years of combined experience • 100,000 miles at sea • USCG Licensed  
**Capt. Phil Howe (415) 290-1659 • Capt. Greg Snead (415) 846-6919**  
We'll get the job done in a safe, professional manner • Call for details

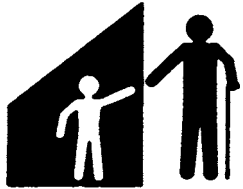

# AGAPE VILLAGES

**FOSTER CHILDREN NEED YOUR HELP!**



Donate your boat to support

**AGAPE VILLAGES**

Tax Deductible

**1-800-513-6560**

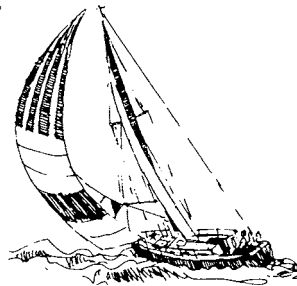

**HUNTER 356, 2003.** Excellent condition with many options including refrigerator/freezer and flat-screen TV/DVD player. \$104,900. Low price because there are no brokerage fees. (801) 419-4100. See full details at: <<http://web.mac.com/laynegalloway>>

**VAGABOND 39 BLUEWATER CUTTER.** Beautiful fiberglass sailboat, built in 1984. Shows like new. New professionally applied Awlgrip, new mast, new boom, new sails, new rigging and halyards. Plus lots more new. \$106,000. Tons of pics and info at: <[www.sailboatunity.com](http://www.sailboatunity.com)> Email: vanjerm@yahoo.com.



**GULFSTAR 37, 1977.** Recently rebuilt Perkins 4-108. Radar, GPS, VHF, Autohelm, electric windlass, Harken roller furling, speed/depth, dodger/bimini, dinghy and motor. Roomy with 6'4" headroom, teak and holly sole, super clean. Lots more. Excellent condition. Great cruiser or liveaboard. \$49,000. Call Don in Ventura: (805) 672-0007 or email: ddrobertson@adelphia.net for specs and pics.

**MUMM 36, 1994. PRICE REDUCED.** HDA Champion. New North 3DL main, 2007 sprayed-on racing bottom. Yanmar saildrive, Flex-o-Fold prop, GPS with cockpit repeater, full Sunbrella boat-cover. Rod rigging, regularly owner-dived. Newer lines/halyards. Sleeps 6. \$52,900. Full specs/photos, contact info: <<http://mumm36forsale.com>>

**40 TO 50 FEET**



**HANS CHRISTIAN 48 CUTTER,** commissioned 1990. One of only two aft-cockpit 48s ever built. Dependable Luger diesel, 8kw Panda, new electronics, radar and autopilot. Huge fuel and water capacity. Spectacular teak joinery. This boat was built for one of the owners of Hans Christian as a showboat for the company and is arguably the finest boat built by that respected firm. A floating palace and a powerful sailer. \$289,000. Tom (510) 525-6168.

**ISLANDER FREEPORT 41.** Incredible boat at a good price. Asking \$65,000. Everything a Freeport fan could want, including roller furling on 4 sails. In San Carlos, Mexico. Too much to list. See: <[www.freeport41.com](http://www.freeport41.com)> or call (720) 221-8295.



**BILL TRIPP COLUMBIA 43.** Achilles inflatable with 9.9 Evinrude. 2 Garmin plotters, 2 sounders, refrigeration, Ray autopilot. Good condition in northeastern Panamanian Islands. \$45,000/obo. (928) 910-2288 or rockndammer@yahoo.com.



**CHALLENGER 50.** Ketch-rigged motorsailer. Dry-stored 10 years, needs new owner. 4-236 Perkins, 12.5kw Koelher, 500-gal fuel, 500-gal water. Email: captmikejd@aol.com.



**ANACAPA CHALLENGER 42.** Center cockpit. Heavy-built full-keel cruiser. Real queen-sized mattress in master cabin. Sleeps 6, fully enclosed cockpit, 12' dinghy with 6-hp ob. Large gourmet galley, Isotemp refrigerator/freezer, Isotherm water heater, Princess oven/stove, all new. Quantum jib, main, spinnaker. Redundant electronics: 3 VHF's, ICOM SSB with Pactor III email, upgraded. New Furuno DGPS antenna. New Nobeltec WAAS antenna. 235 gals fuel. Primary fuel tank completely cleaned, resealed from inside. New FilterBoss dual fuel filter and polishing system. Hydraulic windlass, new chain, 3 anchors. 5 new Lewmar hatches, new Bomar portlights throughout. No leaks. Solar, wind, lifeboat, kayak, plus spares. 100-hp SD33 engine. New cylinder head and ss muffler. New Nobeltec AIS system. \$85,000. Call (916) 880-8896 or jhardi95616@gmail.com.

**MARINE SURVEYS by Captain Alan Hugenot**  
Naval Architect • Yacht Delivery Skipper  
Accredited Marine Surveyor (SAMS)  
••• Bay or Delta • No Travel Charges •••  
All major credit cards accepted • (415) 531-6172



**VOLVO PENTA**

Specialist Dealer Since 1980  
ESKELUND MARINE • (510) 523-7670  
1913 Clement Ave • Alameda Marina • Bldg 13 at Pier 2

We care about sail care!



**San Francisco Service**

773 Andersen Drive, San Rafael, CA 94901

T: 415-453-2142 M: 510-333-4644

Hours: 8-5 M-F, Sat. by appointment

SAIL CARE ■ SAIL COVERS ■ YACHT COVERS ■ FLAGS ■ CRUISING PRODUCTS

Faster by Design  
[www.northsails.com](http://www.northsails.com)

Bay Area Marine Surplus



**MARINE CONSIGNMENT STORE**

Bring in that excess equipment. Find the part you've been hunting for. Engines, sails, hardware, brass, electrical, pfd's and much more. Come in and browse.

130 Old County Road, Brisbane - tucked in the corner of the Brisbane Village Shopping Center, just off Hwy 101.

415 508 0805 [www.bamsurplus.com](http://www.bamsurplus.com)





**COLUMBIA 45 KETCH.** Nice liveaboard. Valued at \$60k last survey. Heart attack creates need to sell the boat. Needs engine work and some TLC. Make an offer. (510) 566-2607 or [vastinethomas@yahoo.com](mailto:vastinethomas@yahoo.com).

**BALTIC 43, 1987.** A truly beautiful and well-cared-for vessel, one of only 47 in the world. Fast, responsive, fun to sail and is well suited for daysailing or extended ocean passage. Berthed in Sausalito. \$210,000. <[www.sfdolphindance.com](http://www.sfdolphindance.com)> (831) 684-2457.



**WAUQUIEZ CENTURION 45.** High quality, very safe performance cruising yacht by Wauquiez, designed by Dubois with stellar record for fast, comfortable offshore passages. Solid FRP hull, masthead sloop, removable cutter stay and stays'l, dyform rigging, owner's layout, fine European joinery. Icom SSB and VHF, Furuno radar, Garmin GPS, Raymarine ST 7000 autopilot, Harken furling, full-batten main, Windpilot servo-vane, swimstep transom, Lofrans electric windlass, dual refrigeration, new Balmar alternator/smart charger, 1000w inverter, AGM batteries 2006. Too much to list. Priced to move at \$179,000. 04/07 drydock survey available. Caribbean, South Pacific, Hawaii passages with up to 200 mpd made good. This boat can go anywhere you want. Photo catalog and inventory available. For more info contact: [tunes@aloha.net](mailto:tunes@aloha.net) or call (808) 826-6050.



**GREAT LIVEBOARD, \$169,500.** 1979 Hudson Force 50 offshore cruising ketch. 5 staterooms, 2 heads, 80-hp diesel, 220-gal fuel, 260-gal water, watermaker, autopilot, SSB/Ham, liferaft. Specs, photos available. Blaine, WA. (360) 371-0904.

**VALIANT 42, NEVER USED.** Never in salt water. Quantum sails, ProFurl on jib, autopilot, microwave, Westerbeke diesel. Boat is as new, location Valiant factory in Texas. \$295,000. Call Dick May (480) 513-7136.



**47-FT OLYMPIC OFFSHORE** cruising ketch. Ted Brewer design, hand-laid fiberglass to Lloyd's specs, 3 staterooms, spacious accommodations, 75-hp diesel, LPG oven/stove, refrigerator/freezer, hot water, radar, VHF, GPS/chartplotter. See more at: <[www.rebeccasailboat.com](http://www.rebeccasailboat.com)> \$147,500. (360) 452-5050 or (360) 928-3058.



**GULFSTAR 50. EASY, SAFE AND** comfortable. Just finished complete refit. Ready to cruise the world or live aboard. All highest quality: 110 volts, central heating, washer/dryer, life gear, batteries, pumps, sails, seats, bedding, etc. \$124,000. Call Jay (415) 601-2292.



**47-FT CUSTOM FIBERGLASS CUTTER,** 2004. Bluewater high-latitude cruising sailboat. Two helms, one enclosed. Sleeps six, premium equipment, electronics, 85-hp diesel, 4.2kw generator, workshop, 200+ fuel and water, refrigeration, washing machine, insulated. \$549,900. Pictures: <[www.hyssop.com/boat/](http://www.hyssop.com/boat/)> Coos Bay, OR. (541) 888-5688.

**ISLANDER 44 CUTTER.** Lapworth design, 1975. Major refit 1997, upgrades 2006, blister free, Australia vet. Perkins diesel, Furuno radar, liferaft, Alpha autopilot, wheel steering, SSB, furling, dodger, electric windlass, MaxProp, Hypalon inflatable. Includes Moss Landing liveaboard slip. \$47,000. Chris (831) 423-4076 or [boatbrain@gmail.com](mailto:boatbrain@gmail.com).

**1987 SLOCUM 43 PILOTHOUSE.** \$159,000. The Slocum's pilothouse is bright and cheerful with good visibility and is great for cruising and entertaining. You can keep watch from the aft cockpit or inside the pilothouse. Low hour replacement engine. Here is an opportunity to buy at a price that allows installing top-of-the-line upgrades without exceeding the cost to purchase the same boat in a seller's market. Well designed boats don't lose their appeal. Berthed Alameda. Call Robert (925) 484-4629.



**CATALINA 42 3-CABIN, 1990.** Great condition. New bottom April 2008. New radar, dinghy, chartplotter, autopilot, etc. Extensive upgrades. See specs at: <[www.leluya.blogspot.com](http://www.leluya.blogspot.com)> Located South Beach Harbor, San Francisco, CA. \$119,000. Call (650) 279-4817.



**FAST IS FUN.** Win this high-performance cruiser or just a great night on the town for \$200. Is your last night out on the town just a \$200 dollar memory? Email: [svlonestar@yahoo.com](mailto:svlonestar@yahoo.com) for details and pictures.



**ISLANDER 44 SCHOONER, 1982.** Classic look with a fiberglass hull. New main and sail covers, new standing rigging, new bottom paint, low hours on Detroit 100-hp diesel. Very well maintained. Set up to singlehand or great liveaboard. \$69,000. Call (510) 847-2522 or email: [smokenbay@yahoo.com](mailto:smokenbay@yahoo.com).

**MAPLE LEAF 48 SOJOURN.** Just completing a major refit of all cosmetics and systems. Way too much to list here. For pictures and details, visit website: <[www.captfht2.com](http://www.captfht2.com)> (720) 221-8295 or email: [fred@captfht2.com](mailto:fred@captfht2.com).

**CASCADE 42 HS.** Airex core, Perkins 4-108, Hood stow-away, Anderson ss winches, head/shower combo with holding tank. Much more. 90% complete. In Seattle. Trades considered. Call (530) 573-1686 or (928) 577-0420.



**HUNTER PASSAGE 42, 1996.** \$165,000. Ready to cruise with autopilot, SSB, radar, 2 chartplotters, dinghy with outboard, etc. See full details, photos, etc at: <[www.svdakota.com](http://www.svdakota.com)> Richmond, CA. Call (925) 200-9659 or email: [ed@svdakota.com](mailto:ed@svdakota.com).



**ISLANDER PETERSON 40, 1979.** Performance cruiser in Sausalito with transferable slip. Comfortable mahogany interior, lots of headroom and storage. Designed by Doug Peterson, PHRF 72. Constantly upgraded. New Harken st winches, new standing rigging, new thruhulls and valves, Raymarine instruments, radar on aft mast, GPS, AP, inverter, 6v batteries, brand new Balmar alternator and regulator, new ultrasuede upholstery and foam, brand new RF 98% jib, and many more improvements too numerous to list. Haulout and survey Jan. 2008. Asking \$76,500. Call (510) 912-5800 or [allison@webbnet.com](mailto:allison@webbnet.com).

**SAMPSON 40 CUTTER.** Just back from Sea of Cortez. Strong Volvo diesel, 2/3-gal/hr. Newer rigging and sails with Dutchman flaking on main. Roller furling. <[www.svpatriarch.com](http://www.svpatriarch.com)> \$39,000. (707) 961-2080 or [rich@svpatriarch.com](mailto:rich@svpatriarch.com).



**CELESTIAL 48, 1986. REBA.** Spacious, well-built center cockpit ketch. Fantastic boat. Excellent condition. Many special features. Fully cruise ready. Great value. See overview and details at: [www.celestial48.com](http://www.celestial48.com).



**Air – IN**

**Rain – OUT**

**PortVents®**

Portlight Rain / Spray Guards  
[www.eBuyMarine.com](http://www.eBuyMarine.com)

**Marine Architecture**

John Seward  
105 Edison Ave.  
Corte Madera, CA 94925  
(415) 924-0429 • [nims65@gmail.com](mailto:nims65@gmail.com)

*Brochure Available*

**Marine Construction**

Millerick Bros. Coast Marine  
PO Box 357, Cotati, CA 94931  
(707) 829-2507  
(707) 823-1954 (fax)



**YACHT DELIVERIES**

Royal Yachting Association & USCG-Licensed Captain available to deliver your yacht in a safe & professional manner

**Andy Signol (408) 858-2639 • [www.andysignolyachting.com](http://www.andysignolyachting.com)**

*Need Crew? Latitude 38 Crew List A Boat to Crew on?*

Visit our website and sign up as Skipper or Crew • *It's Free*  
Find out about our next Crew Party: Wed. Sept. 10 at Encinal Yacht Club  
More info: [www.latitude38.com/crewlist/Crew.html](http://www.latitude38.com/crewlist/Crew.html) or call (415) 383-8200



## Marina Bay Yacht Club

We're friendly and affordable and accepting new membership applications!

*The Cruisingest Yacht Club  
in Richmond!*

For more information, visit our website at:

[www.marinabayyc.com](http://www.marinabayyc.com)

Email us at:

[TheCommodore@MarinaBayYC.com](mailto:TheCommodore@MarinaBayYC.com)

or call our Commodore at:

**(775) 742-5708**

## DF DIESEL FUEL FILTERING



### Purify Diesel Fuel & Clean Tanks

Process scrubs, polishes, removes algae, dirt, sludge, rust, water, and foreign particles from diesel fuel.

Includes internal tank washdown. Save your injectors, costly engine repair and down time.

*Since 1989. Fully insured. Your berth or boat yard.*

**(510) 521-6797 Fax: (510) 521-3309**

## DONATE BUY SELL CLEAN



- Donate your boat or equipment for a tax deduction
- Learn about our For Sale by Owner program plus tax deduction
- Quality used boats for sale
- Topside cleaning service, \$2.00/foot

*Fundraiser for Ship 65 Sea Scouts  
and Historic Boat Restorations*

**650-380-5535**



**NAUTOR'S SWAN 41/012, 1973** performance cruiser. Fast, sleek and clean. New LP. Factory non-skid decks. New running rigging, lifelines, stanchions, mainsail. New upholstery. Modern electronics, gel cels, low engine hours. Last hauled 5/07. Reduced to \$80,000. (562) 706-4334 or sailfast6@verizon.net.



**VAGABOND 47, 1982.** Full keel, 5.6' draft, 13.6' beam. Fiberglass. Many custom features and upgrades highlight this cruise-ready, center cockpit, cutter-rigged ketch. They include: Aluminum pilothouse, 1-1/2" stainless tubing handrails and bow pulpit, aluminum dinghy landing platform/ladder, electric windlass, 88-lb Delta with chain and rode, 85-hp John Deere, 4.2kw Entec genset, Webasto diesel heating system. Watermaker, Splendide washer/dryer, large aft cabin, 2 heads/shower, fridge and freezer, liferaft, electronics, stainless water tanks 350, aluminum fuel tanks 210. Sails are all roller furled, aluminum masts and much more. Located at City Docks along Hwy 101 northbound, Coos Bay, OR. \$229,000. Email: skboehm.1@juno.com for more information and photos. Call Tim (928) 920-1767.



**42-FT COMANCHE, S&S-DESIGNED,** F/G liveaboard ocean-cruising sloop. Modern underbody, fast, responsive, doublehander. Major rfit: Mast, rigging, sails, wiring, offshore anchor gear, dodger, profurler, interior. ABL portlights, etc. Excellent Perkins diesel, new paint. Priced to sell \$42,950/obo. (415) 713-6876.

**BENETEAU 423, 2003.** Excellent condition, like new, deep keel, 2br/2ba, color GPS, Raymarine instruments, LINK 1000 inverter, folding MaxProp, engine under 200 hours, 2nd anchor, EPIRB, full dodger, extras. Haulout 3/07. \$199,500/obo. Can email pics: hcben88@gmail.com.



**TARTAN 4400, 2004.** Hull #1 of Tartan's newest deck salon. Electric winches, Vacuflush heads, full batten main, roller genoa, cruising spinnaker. Espar central heat, bow thruster. Kato davits, Caribe inflatable. Only 170 hours on diesel engine. New condition. \$475,000. (530) 318-0730 or amgjohn@sbcglobal.net.

## 51 FEET & OVER



**BILL GARDEN-DESIGNED 51-FT** ketch, 1977. Totally upgraded for serious cruising. Excellent condition. Must see to appreciate. \$119,000/obo or will consider trade for 24 to 28-ft powerboat plus cash or trade for small condo. (775) 588-5262.



**66-FT LOD KETCH.** Built and designed by Sir Isaac Thornycroft in 1923. A well-maintained, powerful ocean-sailing yacht. Teak decks and mahogany planks on English oak frames. Lovely on deck and below. The photo says it all. Asking \$199,000/obo. Email: mtbusch@sonic.net.



### LEARN OFFSHORE NAVIGATION

From Celestial to GPS and Electronic Charts  
Course on CD • Instructors via Email

[www.amwnavigator.com](http://www.amwnavigator.com)

### VOLPAR, Inc.

(408) 986-0848 • (800) 258-4545  
Parts / Service • Penta Only  
10am-7pm PST every day including Sat-Sun  
email: [Volpar@Volpar.com](mailto:Volpar@Volpar.com)

**VOLVO  
PENTA**



## CLASSICS



**LYLE HESS 30, 1997.** Classic wooden Bristol Channel cutter. 2 times Wooden Boat Show winner, San Diego Yacht Club. Now for sale in as-new condition. Located Monterey, CA. View on web: <[www.watsonvilledentalclinic.com](http://www.watsonvilledentalclinic.com)> Asking price \$135,000. Call (831) 254-7001.

**44-FT LOA, 36 ON DECK.** 1941 Yawl. Master Mariners classic. Recent survey. Good condition, old usable full inventory of sails. Full boat cover. Lying Marina Bay. Slip available. \$12,000. Pics available. (530) 277-8253.

**WOODEN BEAUTY, 65' LOD KETCH.** Marconi rigged. Traditional oak hoops on raked masts. Shallow draft. Sails nice and in great shape. See more at: <[www.sunstarsail.com](http://www.sunstarsail.com)> or call (530) 467-3173.



**VINTAGE 1945 32-FT YAWL.** *Sirius*, designed by Ralph Winslow, and built by the City Island Boat Works, New York City. She has been out of commission for 3 years in wet storage at the KKM Boat Yard in Richmond. They have just about completed a Spring overhaul with over \$20,000 spent on the yacht. She can be seen at the yard. All of her systems are up and running. Her diesel engine is about 5 years old, and her 4 lower sails are new or almost new. *Sirius* is a fine sailing yacht, not one that just blows around. I can no longer use her; knee problems, mine, not hers. \$30,000. R.C. Keefe (415) 202-0156 or [rckeefe@sbcglobal.net](mailto:rckeefe@sbcglobal.net).

## MULTIHULLS

**39-FT CROSSTRIMARAN.** West Systems cold-molded. Spar Craft mast, 20-hp Yanmar. ProFurl furling. Fresh epoxy in and out. Comes with private, grandfathered mooring in Baja, Mexico, \$38/month rent in exotic, safe location. Needs finishing. \$38,765. (415) 992-8057.

**TRADEWINDS 28 FIBERGLASS** trimaran stretched to 30 feet, strong kick-up rudder, \$6,000. Also have 45-ft aluminum tapered mast, built in New Zealand, \$1,000. Martinez, CA. Ask for Rick (925) 372-7489.



**26-FT CATAMARAN, 2000.** 26' x 15'. Core cell construction, open solid bridgedeck, 9.9-hp 4-stroke electric start, sleeps 4, bimini with 3-sided enclosure. Located near Rio Vista, CA. Asking \$26,000. (916) 203-8517.



**50 X 26-FT TRIMARAN.** Fiberglass over wooden superstructure. 5 berths, 4 queens, 1 king, hot and cold shower, commercial Westerbeke 4-cylinder diesel, runs good. Mast will be stood upon completion of sale. Includes dinghy and 10-hp motor. Moving, must sell. \$37,000/obo. Call Alex (916) 521-9847.

**42-FT CROSS TRI Mk II.** Offshore pilot-house cutter. Fast. Join the 240-mile club, average 10 knots. Asking price \$159,000. If you would like to preview boat go to: <[www.bigblueboatworks.com](http://www.bigblueboatworks.com)> Call (530) 559-7912 or [crosstri@sbcglobal.net](mailto:crosstri@sbcglobal.net).



**PROUT 33 CATAMARAN, 1985.** Ready to sail. Yanmar 23-hp diesel 3GM30F, low hours. Silette independently-steered 1-0 leg prop. 4 sails including furling genoa, all very good. Twin keels, skegs, rudders, shallow draft. Comfortable salon. 2 double-berth cabins, 1 single. Head, holding tank, shower. Propane stove, fireplace, Cold Machine 12-volt refrigerator, watermaker. 3 anchors, line and chain. Topsides, deck new polyurethane paint. Bottom West System barrier coat, new anti-fouling. Never chartered. \$69,000. (928) 581-3516.



**WILDCAT 350, 2000. OUT OF AFRICA.** 35' x 21' beam. Doyle sails, spinnaker, radar, 20-hp Volvo sail drives, folding props. Spectra watermaker. Boat loves Mexico, 4 staterooms. \$169,000. (916) 716-0669 or (916) 777-4756 or email: [rich.cavanagh@yahoo.com](mailto:rich.cavanagh@yahoo.com).



**40-FT PIVER TRIMARAN.** Ketch rig, 25-hp diesel, autopilot, hydraulic steering, on-demand hot water, Chesapeake diesel heating, 4 queen bunks, 2 heads, dedicated shower, 3-burner stove with oven, 2 headsails, 2 anchors. \$33,900. Call Glenn (415) 205-1627 or [ahuber@sbcpcpa.net](mailto:ahuber@sbcpcpa.net).



**WORLD CRUISING CAT LOCATED** in San Francisco. New in 2008: Garmin 34-mile radar/chartplotter, standing rigging, Ppectra running rigging, 250' chain, Fortress anchor, highest quality trampoline. 6 Trojan batteries, fuel system, engines rebuilt, saildrives serviced, battery charger. Lots more comes standard. Only one available on West Coast. Cruise ready. Turnkey. Must see. Great price reduced to \$234,000. Don't let this pass you by. Call (415) 378-4887 or [erik@sailsf.com](mailto:erik@sailsf.com).

**31-FT CORSAIR TRIMARAN, 2007.** Ultimate cruiser. Loaded, 3 sailing hours, new sails, Harken roller furling, Honda 9.9. Pacific trailer, GPS, VHF, full head, galley, water heater, watermaker, autopilot, boat cover, many extras. \$139,000. Call Mat (858) 243-2124.

**37-FT CSK POLYCON CATAMARAN.** Factory built balsa/foam core/ fiberglass. Twin diesels, feathering props, daggerboards. Great boat, great condition. \$60,000/obo. Serious only call (831) 475-6869.

**BROWN SEARUNNER 31, 1982.** Fixed wing, 15-hp Tohatsu, windvane, center-board, mast steps, Norseman rigging, good winches, running rigging, good main, jib, CQR, Danforth, stove, nice interior, cushions, chemical toilet, Whale bilge pump, recent bottom. Richmond berth. \$15,000. [doritodad@yahoo.com](mailto:doritodad@yahoo.com).



**40-FT 2007 SPORT CRUISER/RACER** by Scape Yachts. Fast and fun to sail, 20 knots plus. Epoxy resins/carbon fiber, solar panels, daggerboards, 5 sails, Raymarine, sleeps 6, loaded with options. Brokers welcome. \$387,000. <[www.doubletimecat.com](http://www.doubletimecat.com)> (303) 885-4177 or [wcgallo@msn.com](mailto:wcgallo@msn.com).



**62-FT LUXURY POWER CAT.** \$195,000. Custom catamaran designed for luxury expedition service in Hawaii. USCG COI for 49 passenger service pending. 20+ knots performance, deluxe interior, showroom finishes inside and out. Powered by twin Honda 225-hp outboards with very low hours. Possible killer fishing vessel or re-rig for sailing. Health issues force sale. Listed for under half of \$420,000 insured value. Will respond to any offer exceeding \$150,000. See more photos at: <[www.hawaiiboats-yachts.com](http://www.hawaiiboats-yachts.com)> under 'featured boats'. Call (808) 348-0173.

## POWER & HOUSEBOATS



**STEEL TRAWLER YACHT** under construction. 57' x 15'3" x 6'3" hull, steel work 99% complete. Interior partially finished. Located in Bay Area, can be seen by appointment. (510) 219-1463 (lv msg).

**MULTIHULL DELIVERIES**  
30+ years & 150,000 miles on multihulls • Safe, swift, dependable worldwide deliveries by USCG licensed ASA instructor Capt. Ralph Drahos  
**(831) 334-6028 • Owners welcome**  
Learn multihull sailing and your boat's systems with a professional

**ISLAND PLANET SAILS**  
Low internet pricing • Exceptional service • Attention to detail  
Quality materials from Bainbridge and Dimension Polyant  
World class design team with America's Cup experience  
**[www.IslandPlanetSails.com](http://www.IslandPlanetSails.com) • (510) 931-6499**



## Sea Wolf MARINE SERVICES

Underwater Yacht Maintenance  
Honest • Dependable • Affordable  
**<[www.180seawolf.com](http://www.180seawolf.com)> • (800) Sea-Wolf (732-9653)**

**COMPLETE MARINE WOODWORK**  
Design / Restoration • Expert European Craftsmanship • Interior / Exterior  
Repairs / Maintenance • Marine Windows & Frame Replacement  
Wood & Dry Rot Repairs • Varnish Work • Marine Painting  
**References Available • Reasonable Rates • Call (415) 331-6718**

# The East Bay's Largest Nautical Flea Market at Encinal Yacht Club 1251 Pacific Marina Alameda, California

*Steer Your Way To Great Deals*  
**September 13, 2008**  
**6:00AM - 1:00PM**

- Breakfast
- Lunch
- Beverages

For Information Call  
**(510) 522-3272**

[www.encinal.org](http://www.encinal.org)

## Mathiesen Marine Services

*For All Of Your Electrical & Electronic Needs*

- Systems Design & Troubleshooting
- Marine Electronics Sales & Installation
- PC & Mac Based Navigation Systems
- Electronics Integration/Interfacing
- AC & DC Cables/Charters/Inverters
- Custom Wood Enclosures/Fabrication

**10% Off Labor**  
see Website for Details



1 of only 3  
MasterTechs in CA  
-Fully Insured-

*Check our website for Monthly Specials*

**(510) 350-6622** [www.MathiesenMarine.com](http://www.MathiesenMarine.com)

## Vessel Electric

*Marine navigation installations and expansions  
of existing systems*

- Electrical installs and trouble shooting D/C and A/C systems
- Raymarine® warranty dealer and certified installer
- NMEA-certified Marine Electronics Installer • Insured

**Brian Theobald • (415) 424-2204**  
**vesselelectric@yahoo.com**

**LITTON 41 TRAWLER.** Sea of Cortez. Twin 120-hp economical Lehmans, 4 gph. 5 winters in the Sea as a full-time coastal cruiser/liveaboard. 1978 Stuart expanded with 2 heads, one with LectraSan MSD. 7.5kw Kohler/Yanmar genset. Beautiful teak interior with fiberglass decks. Full beam aft stateroom with full-size lockers and air conditioning. 10' Caribe with 15-hp SeaPro. Instruction included. Marina Real in San Carlos. Asking \$119,000. Email: [onthehook@att.net](mailto:onthehook@att.net).



**PRICE REDUCED. 30-FT WILLARD** Vega Searcher. Excellent little ship for 2, good for 4. Super condition in/out. All systems in excellent condition. Full electronics. All safety gear, full head, 100 gals fuel, 100 gals water. See to appreciate. Call (650) 207-6898 or (650) 851-3402.



**CHRIS CRAFT 28 CATALINA EXPRESS** cruiser, 1977. Great family boat. Sleeps 6, VHF, depth, windlass, 6'5" headroom, repowered with 80+ hours. Berthed at Vallejo Marina. Must sell. \$10,000 \$8,000/obo. (707) 486-9647.



**65-FT WOOD CLASSIC, 1939.** Heavy built ex-trawler. GMC 12V-71, 21-kw generator. Full electronics. Lots of equipment. Ready to go. Would make great conversion. More pics/details: [ancona@mcn.org](mailto:ancona@mcn.org). Will consider any reasonable offer. Call (707) 964-5423.



**1997 KEVLACAT 3400 FLYBRIDGE.** Superior strength and lightweight due to use of Kevlar material. Twin inboard 315-hp Yanmar diesel engines. Catamaran hull tames the rough water and makes for very efficient fuel usage, even with a top speed of 30 knots. Full electronics in turnkey form with low hours, approx. 750. Health forces sale. See more specs, details and pictures at: <http://www.725regal.com> \$130,000. Please call (650) 364-4714.



**CRUSADER 53 BLUEWATER YACHT,** 1980. Excellent general condition. View at: [www.swabbies.com](http://www.swabbies.com) Priced to sell at \$109,500. Call Harvey (916) 622-0436.



**32-FT CLASSIC MONTEREY.** Totally restored Monterey fishing boat, converted to day boat, sportfisher or Bay cruiser. All woodwork has been done. New fuel tanks, hydraulic steering, tinted glass, etc. GMC 2-71 diesel engine. Needs to be finished, such as controls, wiring, exhaust and finishing touches. Must be seen to be appreciated. Will consider any reasonable offer. Pics/details: (707) 964-5423 or [ancona@mcn.org](mailto:ancona@mcn.org).

## PARTNERSHIPS

**WATKINS 36C. PARTNERSHIP** in spacious 36-ft center-cockpit sloop and slip at Pier 39 in San Francisco. Well maintained. Original owners. For cruising the Bay or passage to Mexico. No liveaboards please. [shboatmail-bay@yahoo.com](mailto:shboatmail-bay@yahoo.com) or call (650) 224-8020.

**1/3 PARTNERSHIP. 34' Mainship Trawler** 1983. Summer in the Delta, 9 months in Sausalito. Great family boat. Lovingly maintained. 12' RIB, stern thruster, recently overhauled engine, transmission, windlass, 3.5kw generator, heater, AEK, more. \$18,500/obo. Call Carl (415) 999-2994.



## LONG-TERM CARIBBEAN CHARTER

~ ~ ~ Bareboat or Captained Catana 471 ~ ~ ~

[gfcharter@fusemail.com](mailto:gfcharter@fusemail.com)

## INSTRUCTION • DELIVERIES • COMMISSIONING

Fourth issue 150 ton Master of Sail & Power with experience in every harbor from Victoria to Puerto Vallarta.

Captain Paul Dines from SF Bay Adventures in Sausalito  
**(415) 331-3006 • [www.sfbayadventures.com](http://www.sfbayadventures.com)**



**TWIN PINES SAILING CLUB.** 7 partners own a San Jaun 28 on nice windward berth in Berkeley. Fun group of individuals, share expenses and labor. \$2,500 initiation fee plus \$75/month. Email: dandreini@gmail.com for details.



**PACIFIC 30 PARTNERSHIP.** Canadian built. Gas inboard, slip in Sausalito, good condition. One-half equity partnership \$4,500. Call Mareno (415) 956-2642.

**CATALINA 30 SHARE.** Best Sausalito slip with parking. 5 min. to Bay, 30 to Angel Island. Walk to bars/restaurants. Upgrades: wheel, diesel, cushions, jib, furler and more. Non-equity 25% use, \$290/month. 10 month contract. (415) 332-5442 or Leeloves2sail@hotmail.com.



**BENETEAU 500. 1/3-EQUITY PARTNERSHIP.** \$15,000 and share monthly costs/balance of loan. 4 cabins, 4 heads, crew quarters, well maintained. SF Marina berth. Possibly to Mexico/Caribbean 2009. Prefer experienced sailors. Also day or weekend charters to experienced sailors. daveanstead@gmail.com.

**ONE-THIRDTIME SHARE IN Catalina 30** sloop. New sails, repowered with 24-hp Yanmar, wheel steering, original owner, clean, easy daysailer. Located San Francisco. \$300/mo. (415) 731-4956.

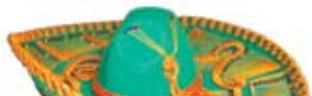

## SOUTH OF THE BORDER

**HOGIN SAILS MEXICO,** Bob Hogin and Laura Murillo. Open in Barra de Navidad, Jalisco, Mexico, from September through June. All types of sail repairs, recuts and rebuilds. New or replacement roller furler covers and cover repairs. Astrup sunbrella available. Email: bhogin@hotmail.com. One block from Capitania de Puerto office. Call in Barra: (315) 355-8390. I monitor Cruiser's Net in season and can meet you at dock to pick up sails. Turnaround time for repairs is a few days.



### CARMINE MARINE SERVICE

Electrical • Mechanical • Diesel • Watermakers  
Dean Carmine (415) 435-8045 • (415) 246-8370  
Marine Engineer dinocarmine@comcast.net



### OFFSHORE PASSAGEMAKING INSTRUCTION IN THE ATLANTIC

John & Amanda Neal are dedicated to providing hands-on, documented instruction aboard their Hallberg-Rassy 46 *Mahina Tiare III*, drawing on their combined 472,000 miles and 63 years of experience.

www.mahina.com • (360) 378-6131

**LEARN TO SAIL** in the Sea of Cortez. San Carlos Sailing School, an ASA school based in San Carlos, Sonora. Specializing in learn-to-sail cruises, vacations. Also offer boat rentals, day trips. See: <http://mexicosailing.com> or please call (800) 874-4830.

**CONDO RENTALS NEAR VALLARTA** yacht club. Two adjacent condos overlooking Paradise Village Marina. Each 2 br, 2 bath with Jacuzzi, pool and amenities. Access to Sports & Beach Club. Rent one or both. Call (925) 208-1601 or 011-52 (322) 297-7559 or nancywmoore1@aol.com.

**PLAN YOUR MEXICAN GETAWAY NOW** at the brand-new, gorgeous Cielo Y Mar condos. Located in Punta Mita, 35 minutes from Puerto Vallarta, available to rent from private owner. Right on the beach, 10 feet from the water, they offer spectacular views of ocean and mountains, the biggest infinity pool in the area, an endless beach, great advanced and beginning surf breaks, great fishing, tremendous views of whales, bird life and the islands. While uncrowded and tranquil, it's just a five-minute walk to several waterfront restaurants. Choose from a spacious and beautifully furnished one or three-bedroom unit, or an amazing two-story penthouse with lovely shade trellis on the top floor. See details: <www.puntamitabeachfrontcondos.com> To reserve, call (415) 599-5012.

## TRADE



**TRADE 1980 CESSNA TURBO 210** for large sailboat. Fast, 200 mph 6-place aircraft, 200H SMOA. Email: donwexler@hiddenwoods.net.

**WILL TRADE MORTGAGE-FREE HOME.** 3 bedroom, 1-3/4 bath on 1/4 acre. Near lake with mountain views. Turnkey. Wanted: 40+-ft fiberglass bluewater cruiser. Ready to go. No fixer. Prefer in Mexico or SoCal. Call (760) 379-6369 or write: PO Box 1685, Lake Isabella, CA 93240.

## WANTED

**GIVENS OFFSHORE 4/6 MAN,** Aerogen #3/#6 gen. Call (808) 291-3233 or email: aeolus\_99@yahoo.com.



## GEAR

**BRITISH ADMIRALTY OCEAN** *Pas-sages of the World.* Jordan series drogue, galerider, storm chute, storm drogue, 4 survival suits, survival kit, offshore medical kit, Mexico and South Pacific charts and cruising guides, boom brake, Fridell and tri-lens radar reflectors. Call for prices. (415) 216-3404 or (619) 277-0593.

**HARKEN B65.3STR RACING WINCHES.** Two including Base Riser, \$9,000/obo. Installed new on a J/133 early 2007 and removed late 2007. Moderately used during cruising and club races only. In excellent condition. Call John at (408) 234-4402 or email: john@castlerock.com.

**SCANMAR MONITOR WINDVANE, 2001.** Four 17" lower tubes, cut upper tubes, \$2,400. 2004 Elliot four-person coastal 'A' pack liferaft in canister with mount, \$900. Four Pelican hooks, 3/16 wire, hand crimp, \$100. (650) 563-9686.

**40-HP 4-CYLINDER UNIVERSAL** diesel with v-drive tranny, \$2,900. 13-hp Westerbeke diesel with velvet-drive tranny, \$1,950. Atomic 4 rebuild, cherry, \$2,950. Anybody interested in a hybrid diesel electric? My trained cockroaches can build one. (415) 272-5776.

**NOAA CHARTS, NEVER BEEN USED.** If you have a chartplotter, you still need a paper backup. South Pacific, Hawaii, Mexico, Oregon, Washington, California and Caribbean. \$7/each plus postage. Used charts too. List upon request. (949) 497-8645 or sailslady@aol.com.

**ANDERSON WINCH SS 46 ST,** \$600. 12-ft fiberglass 2-person nesting dinghy, \$700. (916) 777-5138 or (916) 777-6792.

**TWO VOLVO 2020 DIESEL ENGINES** with sail drives. Excellent condition, \$4,000/each engine. Also, Bauer dive compressor, 225 Bar. Less than 150 hours. Powered by Honda 5.5 engine on steel frame. \$3,000. (415) 999-6446.

**USED BOAT GEAR WANTED.** Looking for sailboat hardware, anchors, chain, winches, propellers, small outboards, inflatable dinghies, boarding steps, propane stoves and other used boat gear. Must be in very good condition and priced reasonably. Email list: isaacson\_mark@yahoo.com or call (510) 295-9638.

**FW MANIFOLDS: 4-108/3GMF,** Lewmar 2000 windlass, Trace inverter, outboard mount, BBQ, Raritan pressure water system, Velvetdrive, HT anchors, v-drive, Avon: mounts/seats, 2-spd winches, outboards: 2.5-8hp, Edson pump, dorades, traveler, dive gear, paranchor, bow roller, cruising library, clock/barometer, charts, booms, headsails. (415) 497-3731 or brad-low@sbcglobal.net.

**HYDROVANE, \$1,800.** Seagull outboard, \$600. CNG tank, \$40. L10 Caribe hard bottom, \$1,200. Spinnaker and jib for a Freeport 41, \$500. Merc Cruiser diesel with OMC outdrive, 4 cylinder, \$500. (530) 541-3525.

**EMERGENCY RUDDER SYSTEM** for 40+-ft sailboat with IOR-type transom. The system was designed to fit in the sail locker of Beneteau 1st 42. Meets Category 1 requirements. \$600/obo. (408) 689-7753.

**CRUISING GEAR.** 300' 5/8" nylon anchor rode, 160% light air genoa, Pfaff 130 sewing machine, 2 Henri Lloyd foul weather jackets (M, L), North foul weather pants (XL), Henri Lloyd foul weather pants (XL), misc. hardware. Bill (530) 747-6471.



**MASTERVOLT 3.5KW 115VAC** marine generator with Kubota oil-cooled oo60 diesel. \$4,000/obo. Very compact, 16 x 20 x 20h, 210 lbs, delivers 3.0kw continuously using one qt. of fuel hourly. 450 hours since new in 2004. Excellent condition, enclosed in green and white sound enclosure. Very quiet. Used as backup generator in hybrid propulsion system. Will deliver if requested on cost basis. Call (916) 792-1614 or email: sv.ryden@yahoo.com.

**SPECIAL 15-HP SAILBOAT** outboard, full reserve power, very good condition, \$850. Sails and mast for Santa Cruz 27, like new, four sails, mast and boom, \$1,500. All or part. Call for all specs (510) 830-7982 (eves after 6pm).

## MISCELLANEOUS

**PFUFF 130 SEWING MACHINE.** sews leather, sail and light material with variety of stitches. Hand crank and electric with pedal. \$700. Call (360) 450-3749 or email: kjincoln8@yahoo.com.

## CLUBS & MEMBERSHIPS

**SINGLE SKIPPERS AND CREW** of all abilities are invited to attend Single Sailors Association's <http://www.singlesailors.org> meeting held 2nd Thursday, Oakland Yacht Club, 1101 Pacific Marina, Alameda, 94501. Social 6:30 pm. Meeting 7:30 pm. Members enjoy daysailing, rattups and social events. Guests welcome. (510) 233-1064.

### BLUE PELICAN MARINE

A sailor's consignment store now open at Grand Marina, Alameda  
Sails • Winches • Instruments • Brass • Collectibles • Sailing Books  
Charts • Small Outboards • Hardware • No large items • No junk  
(510) 769-4858 • bluepelicanmarine@sbcglobal.net

*Want to Crew?* Latitude 38 Mexico Crew Party *Baja Ha-Ha?*

Wednesday, September. 10 • 6-9 pm • Encinal Yacht Club • Alameda  
\$7 entry fee • Munchies • No-Host Bar • Door Prizes • Demonstrations  
More info: <www.latitude38.com> Crew List/Next Party or call (415) 383-8200

weatherguy.com

## Worldwide Marine Forecasts Cruising, Racing & Commercial

Packages Starting at \$50.00 USD

(866) 882-WXGY (9949) toll free  
(808) 291-WXGY (Mobile)  
(808) 254-2525 (Office)  
(808) 254-1525 (Fax)



970 N Kalaeo Ave  
Suite C-109  
Kailua, Hawaii 96734  
info@weatherguy.com

www.weatherguy.com

## ATLANTIC 57 CATAMARAN™



THE ORIGINAL PILOTHOUSE CATAMARAN  
o Designed for easy shorthanded cruising  
o Spectacular windward performance  
o Cored epoxy/glass/carbon construction

**CHRIS WHITE DESIGNS**  
TEL: 508-636-6111  
www.chriswhitedesigns.com

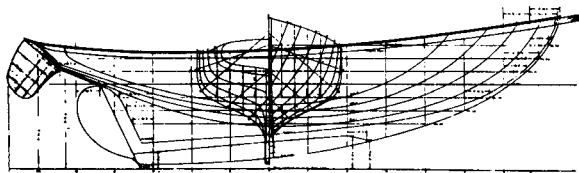

## MAKELA BOATWORKS

Family owned since 1948

Wooden Boat Building • Repair and Restoration

19280 South Harbor Drive • Fort Bragg, CA 95437

**(707) 964-3963**

email: howard@makelaboatworks.com • www.Makelaboatworks.com

**MARINA DE LA PAZ** FULL SERVICE MARINA  
S.A. DE C.V.

*Friendly, helpful, fully bilingual staff*

All new hardwood docks • Wireless Internet  
Dinghy landing with potable water  
New protective piling & sheetpile breakwaters • And more!

TEL: 01152 612 122 1646  
email: marinalapaz@prodigy.net.mx  
www.marinelapaz.com

Apdo. Postal 290, La Paz, 23000, Baja California Sur, Mexico

Official Sponsor  
2008  
BAJA  
HA-HA

## NON-PROFIT

**MARIN POWER & SAIL SQUADRON** offers members free classes ranging from Seamanship to Celestial Navigation plus cruises and social events. Next Squadron Boating Course in Novato September 9, 11, 16, 18, 23, 25, 2008, all from 7 to 9 pm. Textbook \$50. For details and registration call (415) 924-2712.

**SAFE BOATING NO ACCIDENT.** Santa Clara Power Squadron promotes safe boating. Boat Smart Class: Wilcox High School, 3250 Monroe, Santa Clara. Classes are four Tuesdays, starting September 30, 2008, 7-9 pm. Cost \$30 for materials. Call (408) 225-6097.

## JOB OPPORTUNITIES

**BAY AREA MARINA** looking for manager. Send resumé to: mexexecutive91@gmail.com.

**25 TON, 50 TON, AND 100 TON** captain(s). Yacht charter business out of Sacramento. 350-passenger, 130-passenger, 40-passenger, and 20-passenger vessels. Operate exclusively on the Sacramento River. Good people skills required. Class B drivers license in conjunction with captain license would be great for our amphibious vessel. Requires great attitude and professional appearance. (916) 552-2933, ext 114 or mplewe@sacyachts.com.

**CAPTAIN / DIRECTOR MARINE** Operations. Seeking 100T-plus neat Captain for 100-ft 149-passenger charter yacht; 80-ft Montefino private fiberglass yacht. Adept at engine and yacht maintenance. Excellent organizational, managerial and computer skills. Resumé to: YachtLadysf@aol.com or call (415) 409-1888. <www.YachtConnectionsInternational.com>

**BOATWORKER &/OR OFFICE ASST.,** Sausalito. One or two people, start pt, can become ft career position. Help with business, organization, upgrading boats. Interests in mortgage and real estate brokerage, Hawaii and south of the border real estate, boat remodeling, sales. Lodging possibly included. (415) 331-5251.

## BERTHS & SLIPS

**50-FT SLIP AVAILABLE.** Alameda/Oakland Estuary. \$350/monthly includes utilities. Call Frank (510) 533-2273.

**40-FT SLIP FOR SALE.** It is located on E-Dock at Pier 39 with great views. Asking \$15,000/obo. (415) 602-0930 or mkbarney@earthlink.net.

**SAN CARLOS, MEXICO 40-FT SLIP** available for sublet November 2008 – March 2009. Shower facilities, water, and electricity included in the \$550 monthly reduced fee. Call Dennis Cannon (480) 951-0827 or email: lynncannon1@msn.com.

**OWN YOUR OWN SLIP IN EMERYVILLE, CA.** This is not 'right-to-lease' fee, this is 'real estate' purchase. You own the slip. 45' x 14.5' slip, beautiful marina, very protected, on Bay. All amenities provided, \$56,000. Assumable note available. David (831) 818-4206.



## TRYING TO LOCATE

**LOOKING FOR MY 23-FT Ed Monk-** design, 3/4-rigged sloop. Japan built, 1955. All wood. Sold her in 1989. (831) 685-3502

**WHERE ARE YOU ETAK?** 42' Pahi Wharram that we built. Mark Nola ran without paying in 2000. Maurice (360) 450-3749.

**LOOKING FOR INFO RE: BILL AND** Sandy and Cody Nern and their Commander 47, *Hibiscus*, which they sailed out of San Rafael, CA in 2005. Just hoping all is well. Email Roger Hatchett: RTH415@aol.com.

## BUSINESS OPPORTUNITIES

**MARINE CONSIGNMENT STORE.** Established, busy, turnkey money-maker. Excellent marina/boatyard location. Plenty free parking, low overhead, in Alameda. Price includes all equipment, fixtures, part inventory. Sailing/boating experience necessary, people skills a must. \$20,000, terms negotiable. bluepelicanmarine@sbcglobal.net.

**CHARTER BUSINESS FOR SALE** in Puerto Vallarta, Mexico. Turnkey and can be owned by Americans. Call Capt. Peter Vines toll free: (877) 301-2058 or email: vallartafishing@hotmail.com for more info.

**WELDING AND FABRICATING** business with excellent reputation and solid client base for sale on Washington's Olympic Peninsula. Sale includes all equipment and raw materials in the 4,200-sq-ft. building with 3-phase power. Business, two-bedroom two-bath home, and oversized double garage with upstairs guest room and bath are on 9+ wooded acres within a quarter mile of two saltwater marinas. \$624,000. Email: broweld@olympen.com.

## N.E. MARINE TITLE

Coast Guard documentation • Title/lien searches • Transfers • Mortgage filing • Escrow services  
Local closing facility for brokers or private transactions

30 years experience of doing it right the first time

1150 Ballena Blvd, Alameda, CA • (510) 521-4925



Let Your Boat Make Money • Charter It

NEW and HUGE TAX BENEFITS  
www.spinnaker-sailing.com



Spinnaker Sailing • South Beach Harbor, SF • (415) 543-7333



## TOO LATE TO CLASSIFY

**NAUTOR SWAN 38, 1974.** Sparkman & Stephens, powerful, uncluttered. Racing deck layout, rich warm woods below, plenty stowage, separate navigation area, galley, 8 bunks. New jib and main, new teak deck 2004, 4 spinnakers, great inventory, B&B instruments. \$160,000. (510) 435-8141 or femail2@comcast.net.



**K-38, #35, JUBILEE.** Wooden racing/cruising 7/8-rigged sloop. Beautiful custom interior with boat covers. New rigging and ribs in 2004. Bronze-fastened Honduran mahogany on oak ribs. Atomic 4 with new carb. and electronic ignition. Cruising spinnaker, 2 jibs and main. Everything works, no dry-rot, well maintained. 99% original. Year-round, well-protected mooring available, with liveboard option. Owned by shipwright. Additional photos: <www.kettenburgboats.com> Reduced from \$25,000. Call (831) 840-2417 or (831) 840-1697 or email: kimbabwhey99@yahoo.com.

**SAUSALITO OUTSTANDINGVIEW** berth. 44-ft LaBelle Trawler. Volvo diesels, 500 hours, 7.5 Onan. Roomy glass-enclosed sundeck. Full canvas. Large custom galley. Master with walkaround queen, tub + comfortable guest stateroom with large bed, head. Excellent workmanship/condition. Asking \$145,000/negotiable. May finance or rent. (415) 331-5251.



**CROWTHER 35 TRIMARAN.** Racer/cruiser, set up for singlehanding. New paint 2008. 10-hp Tohatsu 2006. New nets 2004. Complete sail inventory, autopilot, wind and speed instruments, Garhauer vang, standing headroom, sink, stove. More boat than F-27. \$35,000. Call (818) 500-1631 or caresys@pacbell.net.



## ¿ MEXICO BOUND ? DON'T LEAVE PORT WITHOUT

GERRY

SEA of CORTEZ CHARTS

**YOU DON'T NEED A BIG BOAT  
GET A COPY OF GERRY'S  
Trailer Boating the Sea of Cortez**  
[www.gerrycruise.com](http://www.gerrycruise.com)

## Bilge Steam Cleaning Oil Changes

Professional service at your slip!!!

**MarineLube** 877 744-2244  
[www.MarineLube.biz](http://www.MarineLube.biz)



Fuel Polishing

Tank Cleaning

## HEALTH INSURANCE SERVICES INTERNATIONAL

Cruising south of the border means sailing beyond the horizon of your health coverage.

*Don't let the adventure of a lifetime be cut short by a medical emergency.*

FULL HEALTH INSURANCE • WORLDWIDE COVERAGE  
AFFORDABLE PREMIUMS • EXCELLENT CUSTOMER SERVICE

Arno Chrispeels Life, Health and Accident #OG25078

Arno@healthisinternational.com • 858.750.9080

[WWW.HEALTHISINTERNATIONAL.COM](http://WWW.HEALTHISINTERNATIONAL.COM)

## Quickline Flat Rope & Reel

Easy to use and instantly accessible — Quickline is the answer to storing your mooring, towing, anchoring or extra line onboard your boat.



400 foot length now available

- Self-storing line — NEVER SNAGS!
- Anchor rode, mooring and shore line
- Excellent dingy tow line • 3 Different Reel Diameters!
- 4 Different Line Lengths!
- 2 Different Line Widths!
- Quickline Floating Flat Rope is also available



Quickline USA — Marine Products from the World, for the USA  
15561 Computer Lane #A, Huntington Beach, CA 92649  
Phone: 714-843-6964, Fax: 714-843-6906  
[www.quickline.us](http://www.quickline.us) or [info@quickline.us](mailto:info@quickline.us)

## EASYSTOW FENDERS®

Easy to use and easy to stow. 6", 8", 10" and 12" diameters. Other sizes and models available. Guaranteed tough.

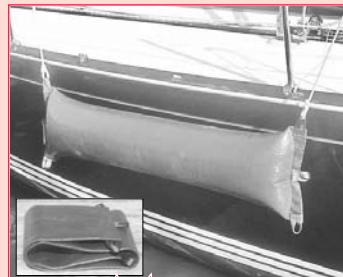

Practical Sailor  
Rated  
BEST CHOICE

PERFECT FOR THE  
BAJA HA-HA!!

[www.easystowfenders.com](http://www.easystowfenders.com)  
(800) 437-7654 • (708) 482-8801

## STANDING RIGGING REPLACEMENT

AT YOUR SLIP!!

Ask About Lifeline Replacement  
Cruise/Race • One Design Fleet Specials

**BUTLER RIGGING**

(510) 672-2639

[butlerrigging@sbcglobal.net](mailto:butlerrigging@sbcglobal.net)



# Your Boatyard in the Heart of Paradise



Large, fenced, secure dry storage area

**Tahiti Customs policy has changed!**  
Foreign Flag vessels can stay on dry storage in our yard for up to 12 months out of 24.



A Subsidiary of  
The Moorings Yacht Charter, Ltd.

## Our Services |



Professional boatyard in the heart of Paradise

Raiatea Carenage will make sure  
paradise is everything you expected.  
Call, write, or sail in . . . we're here to serve you.

B.P. 1111 Uturoa Raiatea 98 735 Polynésie Française  
Tel: (689) 600-545 ~ Fax: (689) 600-546 ~ VHF 68  
Web site: <http://www.raiatea.com/carenage> ~ email: [raiateacarenage@mail.pf](mailto:raiateacarenage@mail.pf)

### HAULOUT

- Marine Travelift 25 tons
- Marine railway 120 tons
- Storage in adjustable steel cradles
- Fenced Yard

### PAINTING

- Topsides, hull, bottom, varnish
- Brush, roller, spray

### MECHANICAL WORK

- Inboard, outboard, diesel, gas
- All brands

### REPAIRS

- Electrical repairs
- Refrigeration installation & repair
- Fiberglass & woodwork
- Welding, steel, stainless, aluminum

### SAIL LOFT

- Sail repairs, biminis, dodgers, covers

### STORE

- International, Pettit, Epiglass, Devoc
- Spares
- Fill U.S. gas cylinders

### DO-IT-YOURSELFERS WELCOME!

BoatUS Cooperating Marina

## QUALITY SAILS FOR LESS!



**MAINSAILS  
MIZZENS  
STAYSAILS  
HEADSAILS  
CRUISING SPINNAKERS  
ALL CUSTOM FIT**

(510) 769-4858 • [leesailsnc@yahoo.com](mailto:leesailsnc@yahoo.com)

2021 Alaska Packer Pl. • Grand Marina • Alameda, CA 94501

**SAILMAKERS TO THE WORLD!**

## WEDLOCK, RAMSAY & WHITING

Marine Surveyors



Pre-purchase, insurance: vessel, engine, rig surveys

Serving the Bay Area since 1980

[www.norcalmarinesurveyors.com](http://www.norcalmarinesurveyors.com)

**(415) 505-3494**

## COMPUTER ABOARD?

CAPN & Digital Charts  
AIS • WiFi • Cellular Amps  
SatPhones: Iridium & Globalstar  
HF SSB Radio & Pactor Modems  
**Wireless E-mail**



**SEATECH SYSTEMS™**  
800.444.2581 • 281.334.1174  
[info@sea-tech.com](mailto:info@sea-tech.com) • [www.sea-tech.com](http://www.sea-tech.com)

Call for Info on SeaTech Packages and CAPN Demo Disk

## Donate your Boat

**Cars, Trucks, RVs, & Real Estate**

We handle all DMV & Smog

Running or Not (restrictions apply)

**Tax Deduction**

**BLUEWATER NETWORK** | **800-324-7432**

"Proceeds help Bluewater Network reduce greenhouse gases, clean up our air and water, and protect marine mammals and wildlife."



**RODGERS & ASSOCIATES**

Certified  
**Marine Surveyors**

As appointed by Boat US Insurance Services  
and Institute of London Underwriters  
ASA - NAMS - LLOYDS



established  
1978

**Tel: 831-475-4468**  
jrogers@rogersandassociates.com

[www.rogersandassociates.com](http://www.rogersandassociates.com)



**MALACHOWSKI & ASSOCIATES**  
Attorney At Law

**Boating DUI Defense Lawyer**

Boating under the Influence of Alcohol  
Collisions, Right of Way Violations  
• USCG Issued Mariner's License / MMD (Z-Card)  
Suspension and Revocation (S&R) Hearings  
• OCMI Determinations

[www.marklawdui.com](http://www.marklawdui.com)  
**Tel: (415) 983-0717**

**VOLVO PENTA**

ENGINES • PARTS • SERVICE

We Ship Anywhere

**1-800-326-5135**

(415) 453-1001  
FAX: (415) 453-8460  
[www.helmutsmarine.com](http://www.helmutsmarine.com)  
619 Canal Street  
San Rafael, CA 94901



**HELMUT'S**  
MARINE SERVICE INC  
AUTHORIZED POWER CENTER

Call us for your nearest Volvo Penta dealer 1-800-326-5135

**Marine Diesel Specialists AT YOUR SLIP!**



30 years experience • Universal/Westerbeke dealers  
Repairs/Tune-ups all models • Engine Surveys, Instruction

**BAY MARINE DIESEL** **510-435-8870**  
[baymarinediesel@comcast.net](mailto:baymarinediesel@comcast.net)

**NEW AND USED SAILS!**

Specializing in production boats and featuring the largest selection of stock sails available anywhere! Save with warehouse volume discounts on Stock Sails, Custom Sails, Sail Covers, Furlers and Accessories. All top Quality.

**All Fully Guaranteed!**

- Full Batten Mains
- Furling Genoa's
- Storm Jibs
- Trysails
- Furling Units
- Custom Canvas
- Used Sails

FAST SHIPPING!



**THE SAIL WAREHOUSE**

**FREE CATALOG!**

**THE SAIL WAREHOUSE**  
Ph. (831) 646-5346 [www.thesailwarehouse.com](http://www.thesailwarehouse.com)

**RPARTS**  
REFRIGERATION PARTS SOLUTION

**100% INTERNET BASED** We carry a complete line of refrigeration parts for maintenance, repair, and upgrades for all brands including Grunert, Glacier Bay, Marine Air, Sea Frost, Adler/Barbour and more. We are also pleased to offer R28+ vacuum insulation panels (independent lab tests) all at Rprices: guaranteed lowest!



**www.rparts.com**

**ADVERTISERS' INDEX**

AB Marine..... 46	Bald Eagle Enterprises/ California Boaters Guide..... 23	Blue Water Marine Paints/ National Paint Industries..... 153	Cal Marine Electronics..... 69	Cruising World Pacific..... 230
ABC Yachts..... 234	Ballena Bay Yacht Brokers..... 16	Blue Water Yacht Insurance..... 133	Caltopia 2008..... 26	Cruising Yachts..... 9
Agape Villages..... 214	Banner Bay Marine..... 227	Bluestorm..... 126	Chula Vista Marina..... 159	CYOA Yacht Charters..... 184
Albatross Yacht Charters..... 188	Bay Area Marine Services..... 214	Bluewater Network..... 222	City Yachts..... 17	Davis Instruments..... 146
Almar Marinas..... 77	Bay Marine Boatworks..... 67	Bo'sun Supplies..... 225	Club Nautique..... 38	Desolation Sound Charters..... 188
Anacortes Yacht Charters..... 188	Bay Marine Diesel..... 223	Boat US Insurance..... 205	Coast Marine..... 226	DeWitt Studio..... 225
Anderson's Boat Yard..... 53	Bay Risk Insurance..... 61	Boomkicker..... 221	Colligo Marine..... 95	Diesel Fuel Filtering..... 216
Annapolis Performance Sailing..... 127	BDI Marine Surveys..... 152	Bottom Siders..... 227	Conch Charters..... 186	Dockwise Yacht Transport..... 87
Aqua Marine..... 168	Berkeley Marina..... 59	Brisbane Marina..... 167	Corinthian Yacht Club..... 23	Downwind Marine..... 28
Aquatic Protection Agency..... 227	Berkeley Marine Center..... 55	British Marine..... 18	Costa Baja Resort & Marina..... 89	Doyle Sails..... 43
Bair Island Marina..... 96	Beta Marine Engines..... 21	Butler Rigging..... 221	Cover Craft..... 93	Easom Rigging..... 75
Baja Ha-Ha Sponsors. 161,162,163	Blue Sky Energy..... 149	BVI Yacht Charters..... 186	Coyote Point Marina..... 57	Elliott/Pattison Sailmakers..... 133
Baja Tourism Board..... 63			Cruising Cats USA..... 95	Emery Cove Yacht Harbor..... 99

# JUST YOU AND THE SEA...

## Punta Mita Beachfront Condos

Call now for winter reservations!

1.415.599.5012

[www.puntamitabeachfrontcondos.com](http://www.puntamitabeachfrontcondos.com)

*environmentally friendly products*



- ◆ No harsh chemicals
- ◆ Organic composting
- ◆ No thru-hulls
- ◆ Only \$850 - includes hoses, brackets, fan



**Nature's Head Composting Toilet**

(530) 383-4217 [www.greenpease.net](http://www.greenpease.net)

**FOR SALE**

**1979 ISLANDER PETERSON 40**

This sleek performance cruiser is a great all around racer/cruiser with a PHRF of 72. All systems have either been renewed or replaced. The interior is very comfortable with 6'6" headroom and 6'6" berths as well as ample storage throughout.



*Sausalito slip*

Doug Peterson design  
LOA 40' LWL 30'10"  
Beam 11'10" Draft 7'2"  
Disp 17000 # Ball 7700#  
**NEW**  
Standing & running rigging  
Bronze thruhulls  
RF headsail 98%  
Raymarine electronics  
AP/Radar/GPS  
Harken ST winches  
Balmar alternator & regulator  
Ultrasuede upholstery  
Custom headliner

The last haul and survey were done in Jan 2008. This boat is turn key!

**Asking \$76,500**

510 912-5800  
510 233-5258

### ADVERTISER'S INDEX - cont'd

Emeryville Marina..... 169	Gerry Sea of Cortez Charts ..... 221	Helms Yacht & Ship Brokers/ West Coast Multihulls ..... 79	Jeanneau America ..... 8	Lifeline Batteries ..... 126
Encinal Yacht Club ..... 218	Gianola & Sons ..... 212	Helmut's Marine Service ..... 223	JK3 Nautical Enterprises ..... 228	List Marine Enterprises..... 189
Essex Credit Corp. .... 16	Glen Cove Marina ..... 189	Hidden Harbor Marina..... 203	Johnson Marine, C. Sherman..... 98	Loch Lomond Marina..... 52
Fago, Margaret Artist..... 97	Go Cats..... 189	Hogin Sails..... 56	Katadyn ..... 207	Makela Boatworks..... 220
Farallone Yacht Sales ..... 7	Golden Gate Yacht Club..... 34	Hood Sails..... 49	Kelly-Hanson Sails ..... 231	Malachowski & Associates..... 223
Flex-O-Fold Propellers ..... 208	Golden State Diesel Marine ..... 225	Hotel Coral & Marina..... 158	Kensington Yachts ..... 230	Maretron ..... 93
Flying Cloud Yachts ..... 15	Grand Marina ..... 2	Hydrovane ..... 152	Kissinger Canvas ..... 208	Marina Bay Yacht Club..... 216
Flying Tiger Yachts ..... 178	Greenpease..... 224	Interlux Yacht Finishes..... 85	KKMI - Brokerage ..... 229	Marina Bay Yacht Harbor ..... 81
Footloose Yacht Charters..... 187	H&S Yacht Sales..... 13	International Marine..... 99	KKMI - Maritime Services ..... 32,33	Marina de la Paz ..... 220
Forespar..... 200	Hanse North America ..... 39	Island Yacht Club ..... 94	Landfall Navigation..... 133	Marina El Cid ..... 158
Fortman Marina..... 10	Hansen Rigging ..... 181	Isotherm / Indel ..... 48	Landing School, The ..... 148	Marina Ixtapa..... 157
Garhauer Marine..... 73	Harken..... 42	J/World..... 74	Larsen Sails/Neil Pryde Sails ..... 88	Marina Mazatlan ..... 206
Gentry's Kona Marina..... 226	Health Insurance Svc Int'l..... 221		Lee Sails ..... 222	Marina Nuevo Vallarta..... 90





Good luck to all the sailors racing in the Rolex Big Boat Series this month!

**deWitt**

Call Pam to discuss commissioning Jim DeWitt to paint your boat racing.

If you give us a 'heads up' that you're interested in a painting, Jim can go out and take pictures of you while you race.

**DeWitt Art Gallery & Framing** 121 Park Place, Point Richmond, CA 94801  
**(510) 236-1401 • (800) 758-4291** [www.jimdewitt.com](http://www.jimdewitt.com)

Tuesday-Thursday 10:00 a.m. to 5:00 p.m. • Friday 10:00 a.m. to 3:00 p.m. • Saturday Noon to 5:00 p.m.

**STAINLESS STEEL**



Strength, Quality and Dependability... plus a Lifetime Warranty!

Stainless Steel Marine Hardware, Rigging & Fittings at Reasonable Prices

See our complete catalog and order on the Web:

[www.BOSUNSUPPLIES.COM](http://www.BOSUNSUPPLIES.COM)

Or call toll-free for catalog and to order

**(888) 433-3484**

**GOLDEN STATE DIESEL MARINE**

**PARTS**  
 YANMAR • UNIVERSAL • WESTERBEKE  
 PERKINS • ISUZU • PATHFINDER • ATOMIC 4

**SERVICE**  
 DIESEL ENGINES

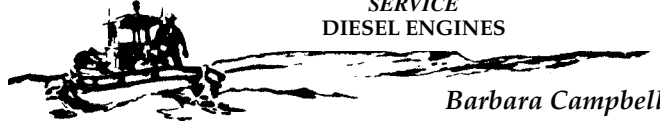

Barbara Campbell

351 EMBARCADERO  
 OAKLAND, CA 94606

**(510) 465-1093**

**ADVERTISER'S INDEX - cont'd**

Marina Puesta Del Sol..... 201	McGinnis Insurance..... 20	North Direct Sails..... 148	Passage Yachts..... 4,5	Raiatea Carenage Services..... 222
Marina Real..... 202	Milltech Marine, Inc..... 72	North Sails..... 214	Peter Crane Yacht Sales..... 231	Randall Burg Yacht & Ship..... 232
Marina Riviera Nayarit..... 209	Mission Creek Sail Tours/ SF Sail Tours..... 189	North Sails - San Francisco..... 54	Pier 32 Marina/ Harbor Island West Marina..... 156	Richardson Bay Marina..... 20
Marina Village..... 71	Modern Sailing Academy..... 45	NW Yacht Brokers Association..... 24	Pineapple Sails..... 3	Rigworks..... 84
Marine Engine Company..... 212	Moorings..... 185	OnlineMarineStore.com..... 97	Port Townsend Shipwrights Coop..... 127	Rodgers & Assoc..... 223
Marine Lube..... 221	Napa Valley Marina..... 60	Opequimar Marine Center..... 160	Prime Fabrication..... 227	Rooster Sails..... 127
Marine Outboard Company..... 227	Nelson Yachts..... 232	Orange Coast College..... 91	Puerto Lucia..... 155	Ryan's Marine..... 212
Mariner's General Insurance..... 86	Nelson's Marine..... 236	Outboard Motor Shop..... 206	Punta Mita Beachfront Condos..... 224	Sail California..... 30,31
Maritime Institute..... 50	New England Ropes..... 92	Owl Harbor..... 142	Pusser's Rum..... 6	Sail Warehouse, The..... 223
Marotta Yachts..... 233	New Era Yachts..... 230	Oyster Cove Marina..... 147	Quantum Pacific..... 35	SAS Yachts..... 228
Mathiesen Marine..... 218	No. California Fall Boat Show..... 51	Oyster Point Marina..... 24	Quickline..... 221	Sailrite Kits..... 64
Mazatlan Marine Center/ La Paz Yachts..... 19	Norpac Yachts..... 235	Pacific Coast Canvas..... 95	R-Parts..... 223	Sailtime..... 82
McDermot Costa Insurance..... 200	North Beach Marine Canvas..... 69	Pacific Yacht Imports..... 11		Sal's Inflatable Services..... 202
		Paradise Cay Yacht Harbor..... 22		San Francisco Boat Works..... 179

# COAST MARINE

## & INDUSTRIAL SUPPLY INC.

398 Jefferson St. San Francisco - On the Wharf.  
 Call **Bruce Becker** or **Clark Atkinson**  
 (415) 673-1923 (415) 516-4860  
**800-433-8050**  
 Fax (415) 673-1927



### LIFE RAFT

#### Sales & Service

**U.S.C.G. Approved Testing Facility**

- ★ U.S.C.G. life raft facility for Solas commercial yacht and fisherman rafts
- ★ COMAR DEBARKATION LADDERS
- ★ COMAR PILOT LADDERS
- ★ COMAR WORK LADDERS
- ★ All U.S.C.G. approved



**GUINNESS** "World's longest tested ladder 320ft."  
 WORLD RECORD

Major Distributor for:







**IN SAN DIEGO CALL OCEANS WEST 619 544-1900**

# Latitude 38's

## MEXICO-ONLY CREW LIST

### & BAJA HA-HA PARTY



**Make friends and set sail to Mexico!**  
 Photo ©2005 Latitude 38 Publishing Co., Inc.

**WEDNESDAY, SEPTEMBER 10**  
 6:00 to 9:00 pm  
 (no earlybirds please!)

### ENCINAL YACHT CLUB

Pacific Marina, Alameda

**FREE for 2008 Baja Ha-Ha Skippers & First Mates only**  
**Everyone else pays \$7 at the door** (exact change very helpful)

Apertivos ☉ Name Tags ☉ Guest Experts & Demos  
 Door Prizes ☉ No Host Bebidas

Everyone welcome ☉ No reservations required ☉ Come as you are

[www.latitude38.com](http://www.latitude38.com) ☉ (415) 383-8200

## HAWAII

# LONG TERM DRY STORAGE

*Clear Customs at our dock*

## GENTRY'S KONA MARINA

### HONOKOHAU HARBOR

156°1'30" W  
 19°40'20" N

# 888-458-7896

TOLL FREE

The friendliest boatyard in Hawaii

## Wm. E. Vaughan

### Maritime Attorney, Arbitrator & Mediator

17 Embarcadero Cove, Oakland, CA 94606  
 Mail: PMB 232, 909 Marina Village Pkwy, Alameda, CA 94501

(510) 532-1786 • Fax 532-3461  
[evstarmr@sbcglobal.net](mailto:evstarmr@sbcglobal.net)

### Avoid Rocks, Shoals, 'Land Sharks' & Confiscatory Taxes

I have resolved marine insurance coverage, damage claims, warranty and lien disputes. Experienced in drafting and negotiating purchase/sale, charter, builder's contracts and dealing with the IRS, State and local tax agencies.

A life-long, Bay, coastal, Delta racer/cruiser as well as an Officer/Director and/or Counsel of Yacht Clubs and other maritime entities since 1954. Affiliate of the Society of Accredited Marine Surveyors (SAMS).

## ADVERTISER'S INDEX - cont'd

San Leandro Marina .....	14	Selden Mast, Inc. USA.....	70	Switlik .....	203	Vaughan, William E. ....	226	Whitehall Rowing & Sail.....	97
Santa Cruz Yachts .....	29	Shadetree Fabric Shelter.....	19	The Boatyard at Grand Marina...	12	Ventura Harbor Boatyard .....	143	Wichard, Inc. ....	58
Scan Marine Equipment .....	166	Society of Accredited Marine		The Mexican Inn .....	188	Vessel Electric .....	218	Wizard Yachts, Ltd. ....	232
Scanmar International .....	143	Surveyors/SAMS .....	228	Tim's Zodiac Marine.....	166	Voyager Marine.....	21	Wright Way Designs.....	22
Schmidt, Charlotte Yacht Sales .....	231	Solidnav.com.....	159	TMM/Tortola Marine Mgmt.....	184	W.D. Schock Corp.....	93	Yacht 'Islander 40' .....	224
Schoonmaker Point Marina.....	180	South Beach Harbor.....	68	Tradewinds Sailing .....	132	Wagner Insurance.....	154	Yachtfinders/Windseakers.....	18
Sea Frost .....	24	South Beach Riggers.....	69	Trident Funding .....	47	Weatherguy.com.....	220		
Sea Hawk/ New Nautical Coatings .....	44	Spectra Watermakers.....	76	U.S. Power Squadron Dist. 25 .....	25	Wedlock, Ramsay & Whiting Marine Surveyors.....	222		
Sea Scouts .....	216	Starbuck Canvas.....	18	UK-Halsey Sails .....	66	West Marine.....	19,21,23,25,27,83		
Seacoast Marine Finance.....	25	Sunsail Charters.....	40	Ullman Sails .....	65	Western Grace .....	189		
Seashine .....	80	Surface Restoration Group.....	22	US Sailing .....	168	Westwind Precision Details .....	69		
Seatech .....	222	Svensden's.....	37	Vallarta Yachts.....	20	Whale Point Marine Supply.....	62		
Seawear Nautical Jewelry .....	78	Svensden's Marine .....	36	Vallejo Boat Works.....	204	White, Chris Designs.....	220		
		Swedish Marine.....	99	Vallejo Marina.....	41				

Tell 'em  
 Latitude  
 sent you!



## BlueBoater Tip of the Month:

Check your seacocks. Open and close all of them this month. If frozen, time to service/replace.

**APA latest News:** We expand our program into the Delta. We now monitor for illegal pollution in the Monterey Bay National Marine Sanctuary, San Francisco Bay, and the Delta.

## Our Sponsors:

*Boat on the Bottom?*

Call SaltyDingo  
Marine Salvage  
**888-416-7174**



PrePurchase, Insurance,  
and Damage Surveys on  
Vessels with offices in  
Berkeley, Santa Cruz,  
Sacramento, and the Delta  
**888-524-4113**



# DONATE YOUR BOAT

to the Aquatic Protection Agency. We protect our precious coastal waters from illegal toxic pollution. We can use your equipment, so you will get maximum value for your donation.



We are on the water, monitoring cruise ships, performing BlueBoater trainings, and testing outfalls for harmful toxins.

Call **415-235-0756**  
[boats@aquaticprotection.org](mailto:boats@aquaticprotection.org)  
**www.AquaticProtection.org**



**PRIME FABRICATION**  
*Marine Hardware and Custom Metal Fabrication*

- Stainless Anchors - Plow, Fluke, Claw & Ace
- Table Pedestals • Flopper Stoppers
- Helm Seats • Handrails



Ph **949.496.1348**  
Fax 949.496.1341  
[www.primefabrication.com](http://www.primefabrication.com)  
33081 Calle Perfecto, Suite B  
San Juan Capistrano CA 92675

## Anchor Safely with a Banner Bay FinDelta



**25% More Effective**

Unique new twin delta wings work to reduce swinging. You'll sleep sounder.

Order at [www.BannerBayMarine.com](http://www.BannerBayMarine.com)  
or call 201 452 2834

**Banner Bay Marine**  
Products for Cruising in Comfort



## Save Your Aft!

Using one of our 1400+ patterns or your own pattern, let our craftsmen create a comfortable, durable, and stylish set of all-weather cushions for your cockpit. Find your custom, closed cell foam cushions at [www.bottomsiders.com](http://www.bottomsiders.com)!

## BottomSiders

Call Toll Free: (800) 438-0633  
[cushions@bottomsiders.com](mailto:cushions@bottomsiders.com)  
Fax: 360-533-4474

**BottomSiders**  
2305 Bay Avenue  
Hoquiam, WA 98550



## Specializing in

### 2008 NISSAN OUTBOARDS

and

### TLDI TWO-STROKE ENGINES

*Controls & 3-year warranty included. 20% off product and/or labor to veterans.*



Offering 14.5' hand-layed ocean kayaks and  
**INTRODUCING: Lochbaum Seacrafts:**  
Electric-powered kayaks (13'9")

Built in Sausalito • Call for details

**35 Libertyship • Sausalito, CA 94966 • (415) 332-8020**

**VISIT US AT OUR NEW LOCATION!**

Serving the Pacific Northwest Sailing Community Since 1983.

We proudly represent Caliber and Hylas Yachts and specialize in Robert Perry designs and other fine cruising yachts.

**Island Packet 40, 1999 • \$198,900**

Designed by Bob Johnson, *L'Attitude* is a fine example of the Island Packet legacy of cruising performance and livable accommodations. With her full foil keel, furling cutter rig with Hoyt boom, and spacious cabin she's been built to maximize the cruising lifestyle. Having been completely detailed inside and out, she's been lightly sailed and has very low engine hours. Price has recently been reduced making her an exceptional value and opportunity.



**FEATURED YACHT**



**Valiant 42 Cutter, 1995 • \$305,000**

*Whisper* is a beautiful Perry design Valiant 42 in bristol condition and loaded with gear. Upgrades include a repowered Yanmar 50, new holding tank and plumbing, electronics package and autopilot.



Valiant 40, 1975 • \$122,000



40' Valiant Cutter, 1983 • \$164,000



Hans Christian 38, 1977 • \$134,900

[www.sasyachts.com](http://www.sasyachts.com)



**SAIL LISTINGS**

64'	MCS EXPEDITION, 2002	.....	PENDING
43'	PASSPORT, 1998	.....	PENDING
42'	HYLAS, 1988	.....	\$149,500
40'	HARDIN SEAWOLF, 1970	.....	\$64,900
40'	X-119, 1989	.....	\$129,000
40'	CONCEPT	.....	\$69,500
38'	BAVARIA, 1999	.....	\$169,900
37'	TAYANA, 1976	.....	\$84,900
35'	FUJI KETCH, 1976	.....	\$55,000
35'	PEARSON SLOOP, 1970	.....	\$21,500
32'	MORGAN, 1978	.....	\$29,500
23'	STONE HORSE, 1981	.....	\$16,900

**POWER LISTINGS**

50'	DYNAMIQUE, 1986	.....	\$119,000
45'	TOLLY, 1992	.....	\$265,000
40'	NOVA MARINE TRAWLER, 1987	.....	\$119,000
35'	CT TRI-CABIN TRAWLER, 1983	.....	\$58,800
29'	MAXUM, '01	.....	\$49,900
29'	SEA RAY 290 SUNDANCER, 1998	.....	\$45,000

**FOUNDING MEMBER**



7001 Seaview Ave., NW, Suite 150  
Seattle, WA 98117  
206.789.8044 • Toll Free: 877.223.2023  
Fax: 206.789.3976  
sales@sasyachts.com

**JK<sup>3</sup> BROKERAGE**



**53' J/160, 2000**  
Stunning world-class cruiser...\$689,000



**40' J/120, 1999 & 1998**  
Two to choose from...from \$205,000



**40' DELPHIA, 2007**  
New, incredible value...\$219,000



**35' J/109, 2004**  
The best available...\$222,000

- 55' Fairline Squadron, '00 ..... 675,000
- 46' Moody CC, '00 ..... Reduced to 340,000
- 44' Rivolta Coupe 4.5, '08 ..... Call for pricing
- 42' Rivolta Express, '06 ..... Call for pricing
- 42' Rivolta PT Runner, '06 ..... Call for pricing
- 40' Rivolta Coupe 4.0, '08 ..... Call for pricing
- 40' C&C Express, '02 ..... 215,000
- 40' Raider Cabin, '05 ..... 272,500
- 40' Sun Harbor, '80 ..... 39,900

- 37' Delphia, '06 ..... base price 149,900
- 36' Beneteau First 36.7, '07 ..... 169,900
- 35' J/105, '02 ..... 115,000
- 33' Delphia, '07 ..... base price 130,823
- 33' Maxi Dolphin Cross Currents, '06 ..... Call
- 32' C&C, '84 ..... 54,900
- 29' Luhrs 290, '98 ..... 87,000
- 28' Alerion Express, '05 ..... SOLD!
- 25' Hunt Harrier, '07 ..... SOLD!
- 22' Raider RIB 680, '07 ..... 49,690



2330 Shelter Island Dr. #106  
San Diego, CA 92106  
(619) 224-6200  
FAX: (619) 224-6278

Jeff Brown John Bohne Roy Bream  
[www.jk3yachts.com](http://www.jk3yachts.com)  
YACHTWORLD.COM



**Society of Accredited  
Marine Surveyors<sup>®</sup>**

Serving Northern California

Al Blair, SA

415.456.3154

blairsurvey@msn.com

Tom List, AMS<sup>®</sup>

415.332.5478

listmarine@yahoo.com

Jesse Brody, SA

415.342.0757

jesse@baymarinesurvey.com

Randell Sharpe, AMS<sup>®</sup>

877.337.0706

rsharp@alamedanet.net

Alan Hugnot, AMS<sup>®</sup>

415.531.6172

hugnot@comcast.net

Terry Tucker, SA

510.381.1925

ttucker100@sbcglobal.net

Rick Whiting, SA

415.740.2924

captain\_rick@sbcglobal.net



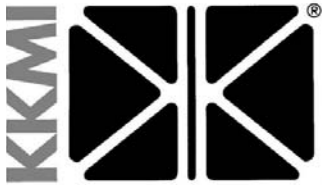

# Maritime Yacht Brokerage

☎(510) 236-6633 • fax: (510) 231-2355  
yachtsales@kkmi.com • www.kkmi.com  
530 W. Cutting Blvd., Pt. Richmond, CA 94804

Ask us about our Maritime Protection Program to find out what a warranty can do for the purchase or sale of your yacht.



### Nelson Marek Custom

A 92-ft aluminum world cruiser. Recently repowered. Immaculate throughout and in perfect condition.

**\$2,850,000**



### Dubois Custom 50' (1989)

Custom two cabin cruising yacht designed by Dubois Naval Architects. Exceptionally well thought out cruiser with many details, *Norther* is robustly built, very comfortable and easily sailed short-handed.

Asking **\$529,000**



### Sabre 402 (2002)

Awarded *Cruising World's* Overall Cruising Boat of the Year, the Sabre 402 is a perfect mid-size boat for the family or shorthanded offshore cruising. Extremely well equipped with Furlboom, electric halyard winch with all lines leading to the cockpit make it very easy for shorthanded sailing. Asking **\$279,000**



### Swan 41 (1977)

Designed by Sparkman & Stephens, the Swan 41 is a very comfortable yacht at sea. Deep lead keel, skeg hung rudder and displacement of nearly 12 tons – the Swan 41 has a reputation as being a 'bullet proof' yacht. Newly installed teak decks, complete sail inventory, electronics. Asking **\$109,000**



### Beneteau First 40.7 *White Dove*

*White Dove* has just won 2008 West Coast IRC Championship and is in top condition. She has been professionally maintained and is ready to cruise with the family or head to the starting line today.



### Fox 44 (2006) *Ocelot*

Tom Wylie/Kernan Yacht Design sloop-rigged offshore racer. Carbon hull and spars, rod rigging, PBO backstay with full complement of sails, and includes trailer.

Asking **\$349,999**



### Swan 42 (2007)

Nautor Club Swan 42. *Amelia* has a winning record and has been prepared for racing at the highest level. All class legal rigging modifications have been completed and a detailed tuning guide is included. Asking **\$780,000**



### Santa Cruz 52 (1993)

Beautiful, fast cruiser, set up for short-handed sailing. Maintained to very high standards, the hull has been repainted in stunning red with new bottom paint.

Asking **\$490,000**



### Grand Banks Eastbay 38 HX (2003)

Premium yacht designed by renowned naval architect C. Raymond Hunt and built by a quality yacht builder. Extensive factory options, comprehensive electronics, superbly maintained.

Asking **\$385,000**



### Hatteras 58 (1973)

High quality tri-cabin motor yacht with flybridge. Full displacement with modified V-hull. Completely enclosed sundeck for comfort in all weather conditions. Very well maintained.

Asking **\$269,000**



Offices Independently Owned

**Call for FREE Report "29 Essential Tips to Getting Your Boat Sold Fast – and for Top Dollar"**

**Cruising World Pacific, Inc.**

1853 Embarcadero, 2nd Floor, Oakland, CA 94606

**(510) 764-1734**

5060 N. Harbor Dr., Suite 165, San Diego, CA 92106

[www.yachtworld.com/cruisingworldpacific](http://www.yachtworld.com/cruisingworldpacific)



DESCRIPTION		24/7 ext.	DESCRIPTION		24/7 ext.
70' Andrews	1998	\$339,000	5223	36' Catalina sloop	1984 \$55,000 7153
52' Tayana CC Cutter	1991	\$295,000	7253	36' Columbia sloop	1968 \$29,900 7163
48' Liberty 458	1983	\$175,000	5173	34' Cal Pearson	1976 \$29,500 7173
47' Beneteau 47.7	2001	\$330,000	7023	34' Pacific Seacraft	1989 \$119,900 7193
42' Catalina	1989	\$116,000	3173	33' Nor'West 33.5	1982 \$39,500 7203
41' Hunter 410	2004	\$224,900	7043	32' Capital Gulf	1985 \$49,995 7213
37' Endeavour sloop	1978	\$55,000	7123	32' Fuji cutter	1977 \$49,900 7223
36' Catalina MkII	2000	\$114,900	7133	31' Prout Cat	1983 \$79,000 5123
36' Catalina MkII	1999	\$113,900	7143	23' Campion Fisherman	\$29,000 4123

**You can receive a boat info sheet via our 24/7 Auto Fax Back  
Call (888) 827-1891 then dial extension**

**PROUT 31, 1983**

Yanmar diesel.  
Two stateroom.  
Auto Fax Back  
**(888) 827-1891**  
ext. 5123



**Want to own a Late Model Yacht?  
Can you use some Tax Benefits?  
Is your boating time limited!**

**Free Report:  
Charter Ownership ~ Is it Right for You?**

**CATALINA 42, 1989**

\$116,000  
Auto Fax Back  
**(888) 827-1891**  
ext. 3173



**NEW ERA yachts**  
POWER & SAIL



47' VAGABOND, 1981 • \$159,900



43' TRADEWIND, 1985 • \$124,500



43' HANS CHRISTIAN, 1999 • \$139,000



41' MORGAN O/I, 1982 • \$99,500



38' HANS CHRISTIAN, 1985 • \$119,500



37' HUNTER LEGEND, 1989 • \$62,500

**SAIL**

40' Acapulco, 1977 .....	\$104,500
37' Beneteau 373 .....	SOLD
36' Cheoy Lee Pedrick, 1986 .....	\$59,000
36' Islander, 1978 .....	\$39,900
31' Hunter 310, 1999 .....	\$59,900
29' Cal, 1976 .....	\$17,000

**POWER**

53' Eagle Pilothouse, 2006 .....	Inquire
48' Defever Long Range Trawler, 1981 .....	\$239,000
40' Albin North Sea Cutter, 2006 .....	\$229,000
38' Californian Sedan Trwlr, 1982 .....	\$75,000
36' Grand Banks Classic, 1992 .....	\$219,000

2021 Alaska Packer Place, Alameda, CA 94501  
sales@newerayachts.com  
**(510) 523-5988**  
[www.newerayachts.com](http://www.newerayachts.com)



**Kensington Yachts**  
*"Everyone needs a bigger boat"*

**UNIQUE, REDUCED COMMISSIONS!**

*Our commission structure is on a sliding scale.*

- Have a large note?
- Two boat owner?
- Death or family emergency?
- Want to trade up?

*We have seen every situation, and understand.*

**Call us today. Let us help you sell your boat!**



36' LANCER, 1981...\$27,900



38' CATALINA, 1984...\$47,900



BAYLINER 3788, 1997...\$154,900



31' SEA HORSE, 1983...\$23,900

**POWER**

45' CALIFORNIAN MY, 1989.....	\$235,000
41' MAXUM 4100 SCA, 2000 ....	\$234,000
38' PACEMAKER, 1973.....	\$37,000

**POWER - con'd**

30' TROJAN, 1969.....	\$9,999
25' MONTEREY 250, 2005.....	\$59,000

**Kensington Yacht & Ship Brokers**  
email: [yachts@kensingtonyachts.com](mailto:yachts@kensingtonyachts.com)  
**877.444.5272 • 415.793.9376**  
[www.kensingtonyachts.com](http://www.kensingtonyachts.com)



## Peter Crane Yacht Sales and Charters

In Santa Barbara - experienced, interested, friendly, low pressure  
Brokerage without walls

Peter Crane (805) 895-1873

Mark Scott-Paine (805) 455-7086



**1980 Skye 51 ketch**  
Kaufmann&Ladd design full cruise  
teak decks, just reduced CALL



**1978 Tartan 38 fixed keel**  
full cruise, receipts over \$250,000  
fully restored, reduced to \$50,000



**1974 Coronado 45**  
great Bill Tripp design  
2 cabins, well equipped \$70 K



**1992 Gulet 89 motorsailer**  
beautiful condition, new cat engine  
6 cabins ea w/ head, shower + crew



**1978 Bertram 28 flybridge**  
specially built 383 cu in twin Mercs  
low hours, handsome \$48,000



**1981 Herreshoff 36**  
traditional good looks in glass  
well equipped jewel \$84,500

Info/photos: [www.petercraneyachts.com](http://www.petercraneyachts.com)  
[pc@petercraneyachts.com](mailto:pc@petercraneyachts.com)  
(805) 963-8000

## Best Price Guaranteed!

**Kelly-Hanson Sails** has been designing and constructing top quality sails for almost twenty years.

### Our Prices

Our business model is a simple one. We build solid cruising sails for popular production boats in volume and sell direct. Our prices are the best in the industry because of our low overhead. We urge you to compare our prices against *anyone's*.

### Riding out the Storm

Kelly-Hanson is the largest distributor of storm sails in the United States, and we are proud to know our products fly on cruising and racing yachts throughout the world. Our storm jibs and trysails are tremendously popular as we regularly produce more than 150 in a normal month. As a result, most models are usually in stock and can be shipped within 24 hours of placing your order.

### Sail Quality

Our sails are built by experienced sailmakers using leading edge technology, premium hardware and Challenge Dacron. They feature premium stitching throughout and include a comprehensive list of standard features.

### Our Guarantee

Purchasing new sails for your boat should be a worry-free, enjoyable experience. There shouldn't be concerns about fit, quality, or the best deal for your sail dollar. Kelly-Hanson ensures your sail purchase is risk free.

### Simply Put:

- We guarantee our prices will be the lowest anywhere - and not just by a few dollars.
- We guarantee your new sail will be constructed with premium hardware and top-quality Challenge Dacron. If you are not completely satisfied with the sail, simply return it and we will refund your purchase.
- We guarantee your new sail will carry a three-year limited warranty against material and workmanship defects.

Call or visit our web site for a Quick Quote before purchasing new sails for your boat. You will be absolutely amazed at our prices and service: We guarantee it.



[www.kellyhansonsails.com](http://www.kellyhansonsails.com)

750 East Kiowa Avenue, Elizabeth, CO 80107

**303.646.0285**

## CHARLOTTE SCHMIDT

YACHT SALES

4100A Harbor Blvd.  
Oxnard, CA 93035  
Fax (805) 382-2374

In SF Bay Area: (415) 613-0712

**(805) 382-2375**

[Csyachtsales@cs.com](mailto:Csyachtsales@cs.com)

[www.yachtworld.com/charlotteschmidt](http://www.yachtworld.com/charlotteschmidt)



**29' HALLBERG-RASSY, 1985**  
Legendary Enderlein/Rassy design.  
High, sharp bow, fantastic profile. Rich mahogany interior, comfortable layout.  
Asking \$49,900



**37' TAYANA CUTTER, 1981**  
Robert Perry design. 40 hp Yanmar diesel, Raymarine chart plotter/radar, autopilot, SSB, dodger bimini. Many upgrades past two years. Ready to cruise! Asking \$97,900



**42' CATALINA MK II, 1996**  
Yanmar diesel, inverter, radar, autopilot, GPS, davits/dinghy, dodger, three state-rooms. Excellent condition.  
Asking \$134,000



**32' NAUTICAT PILOTHOUSE MOTORSAILER, 1996**  
Yanmar diesel, radar, GPS, inverter, refrigerator, air conditioning/heat. Stout offshore cruiser. Asking \$150,000



**51' COOPER PILOTHOUSE, 1982** Lehman 80 hp diesel; radar, chartplotter. Well equipped, excellent layout. A must see for the serious cruiser. Asking \$149,000



**46' BENETEAU OCEANIS 461, 1997**  
Yanmar diesel; electronics package; watermaker, genset. Beautiful interior and well maintained. Asking \$171,000

# Randall Burg YACHT AND SHIP, INC.

Representing over \$38 Million in Pre-Owned Inventory!

Marina del Rey (310) 574-9449  
Newport Beach (949) 675-5940  
San Diego (619) 222-1907  
Alameda (510) 865-1934  
info@rbyachts.com • www.rbyachts.com

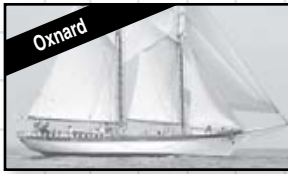

**78' CUSTOM GAFF SCHOONER, 1971** Stunning. Asking \$595,000



**70' CUSTOM NEW ZEALAND MOTORSAILER, 1991,** \$450,000



**51' MASON, 1958** Restored quality classic. \$87,900



**47' KETTENBURG, 1958** \$99,000



**45' STARRATT CENTER COCKPIT KETCH, 1989** Great value. \$85,000

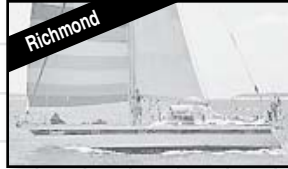

**44' NORSEMAN, 1983** Performance bluewater cruiser. \$228,000



**43' MORGAN, 1985** \$122,500



**38' LAGOON CAT, 2001** Pristine West Coast multihull. \$309,000



**31' PACIFIC SEACRAFT, 1979** Quality full keel double-ender \$69,000



**57' DEFEVER, 1987** \$495,000



**48' DEFEVER, 1980** Elegant & impressive. \$185,000



**42' GRAND BANKS, 1974** Well-maintained classic. \$139,500

**QUALITY LISTINGS NEEDED • OPENINGS FOR SALESPERSONS IN THE ALAMEDA AND SAN DIEGO OFFICES**

## OUR DAILY BOAT SHOW!



**22' MARSHALL CATBOAT**  
A great weekend sailer.  
Diesel powered! **\$35,000**



**32' BAYLINER**  
Fish or cruise in style. Twin diesels.  
**\$45,000**

### SAIL

60'	THURSDAY'S CHILD, '83	\$99,000
54'	SKALLARUD, '61	49,000
50'	HUDSON FORCE 50, '81	129,000
50'	HOLLMAN 50, '89	229,000
48'	CUSTOM CONCRETE	25,000
45'	EXPLORER, '79	125,000
44'	C&C, '86	150,000
41'	AMEL, '80	70,000
41'	CORONADO, '72	29,000
40'	OLSON, '83	85,000
40'	FAST, '80	15,000
37'	HUNTER, '93	85,000
37'	RANGER, '74	29,000
35'	ERICSON, '72	21,000
34'	PETERSON OOD, '79	32,500
32'	COLUMBIA SABRE, '66	6,000
30'	TARTAN, '78	19,500
30'	SANTANA	19,400
30'	CARTER, '76	19,000

30'	CAPRI	12,000
28'	ALBIN SLOOP, '82	13,000
28'	CAPE DORY, '77	28,000
27'	CATALINA, '79	6,000
22'	MARSHALL CATBOAT, '96	35,000
14'	HUNTER 140	4,224
9'	HUNTER XCITE	2,200

### POWER

57'	STEEL TRAWLER	39,000
36'	CARVER, '87	38,000
35'	LARC, '63	90,000
34'	MAINSHIP, '80	49,500
32'	UNIFLITE, '76	24,400
32'	BOUNTY	185,000
32'	BAYLINER, '90	45,000
28'	BAYLINER 2885, '92	32,000
19'	REINELL, '77	3,500
17'	CHRIS CRAFT, '59	14,999
9'	CARIBE INFLATABLE, '91	2,500

**NELSON**  
Yachts  
Carl Nelson  
Douglas Paulsen  
Chad Freitas, Broker

(877) 517-8281  
sales@nelsonyachts.net

www.nelsonyachts.net

## GO FASTER Wizard YACHTS LTD.

Bill Lee  
Dan O'Brien  
Tom Carter



345 Lake Ave., Suite G  
Santa Cruz, CA 95062  
(831) 476-9639 fax (831) 476-0141  
www.fastisfun.com



**SANTA CRUZ 52.** Vic Maui winner. New sails, new bottom. Ready to race. Best racer/cruiser ever. 2 staterooms, 2 heads. **\$399,000**



**COLUMBIA 50.** Club race or cruise, this is one of Bill Tripp Sr.'s best designs. Survey and one-year Santa Cruz slip available. **\$52,500**



**DAVIDSON 50 'Jumpin Jack Flash'** Excellent Pacific Cup or TransPac boat. Very good condition. **\$174,000**



**SANTA CRUZ 50.** New paint, updated sails, major upgrades, water ballast, sprit, excellent short handed boat. **\$146,900**



**CAL 37.** Hot rod Cal 40, new paint, new instruments, new sails, new engine. **\$79,000**



**EXPRESS 37.** Excellent San Francisco Bay boat or Pacific Cup. Category 1 equipment. 1 year Santa Cruz slip possible. **\$74,000**





# Marotta Yachts of Sausalito

Brokers of Fine Sail and Motor Yachts

415-331-6200 • info@marottayachts.com



See at:  
www.marottayachts.com

### 45' ISLAND PACKET, 1998

In very nice shape and well equipped for cruising: three recent Quantum sails, new storm trysail and spinnaker, Hydrovane autopilot and internal B&G 12V autopilot, Fisher Panda 4kw genset, Switlik six-person liferaft, Icom SSB, and more. Just hauled and detailed and shows very well. Lying New Zealand.

\$265,000



See at:  
www.marottayachts.com

### 40' CATALINA 400, 1997

Maintained bristol, this boat has been only lightly sailed and literally shows as new inside and out. Some highlights: Extensive suite of fully integrated electronics, sails show no wear whatsoever, beautiful custom dodger, interior perfect, much more, must see. One of the nicest on the market both in terms of equipment and condition we've seen in years.

\$154,900



NEW LISTING

See at:  
www.marottayachts.com

### 36' CASCADE CUTTER, 1989

Custom-built raised cabintop cutter that was designed specifically for a cruise that was never taken, almost \$30,000 spent over the past couple of years. She shows very nicely today – new electronics, new sails and rigging, low time on the Yanmar diesel and a hard dodger that's a work of art. She's ready to head anywhere you see fit. \$124,900



REDUCED

See at:  
www.marottayachts.com

### 39' GRAND SOLEIL, 1986

Over \$300,000 (this is not a typo!) spent upgrading this Swan look-alike over the past few years: new Yanmar engine with less than 200 hours, sails, rigging, winches, dodger, electronics, interior all redone, much more. Transferable Sausalito slip.

Reduced to \$99,500



REDUCED

See at:  
www.marottayachts.com

### 39' COLUMBIA CENTER COCKPIT, 1979

This yacht had more than \$30,000 spent since 2002 and now shows better than new: rebuilt engine, new mainsails, renewed rigging, replumbed, rewired, replaced original plastic portholes with ABI stainless steel, new custom hard dodger, etc.

\$71,000



See at:  
www.marottayachts.com

### 34' SUNSET SLOOP, 1967

This full keeled little jewel was designed as the ultimate Bay daysailer and built like a piano by Al Silva shortly after he left the legendary Stone Boat Yard. Fully restored, she's one of the finest boats of this era we've ever seen; everything's done to showboat standards.

\$69,500



See at:  
www.marottayachts.com

### 32' BENEteau OCEANIS 321, 1995

Never cruised or chartered, this vessel is IMMACULATE, must see! Wing keel, spade rudder and broad transom provide excellent stability and moderate heel, cockpit very roomy for vessel this size, as is interior, which is done in flawless cherry, huge owner's berth aft. She's also well equipped, competitively priced and lying in transferable Sausalito Yacht Harbor slip. \$69,000



NEW LISTING

See at:  
www.marottayachts.com

### 36' ISLANDER, 1975

With almost 800 launched, the Islander 36 has proved to be one of the most popular 36' sailboats ever built, and this particular example is clean overall with her oiled teak interior in particular showing nicely. Transferable Sausalito Yacht Harbor slip, and there's a long waiting list to get into this marina.

\$40,000



See at:  
www.marottayachts.com

### 37' WAUQUIEZ CHANCE, 1971

The Chance 37 is a classic performance cruiser, and unfortunately rare in the U.S. Which is a shame because with a draft of 6', the boat's a blast to sail on the Bay. This particular example is very nice inside and out, is competitively priced and lying in a transferable Sausalito Yacht Harbor slip.

Significant Reduction to \$29,500

100 BAY STREET • SAUSALITO • CALIFORNIA 94965

THREE



**43' HANS CHRISTIAN, 1989**  
Cutter, Telstar, low hours. \$215,000  
Also: '38', '80...\$92k • '33', '86...\$112k

# Anchorage Brokers & Consultants YACHTS



www.yachtworld.com/anchoragebrokers  
#1 Gate 5 Road, Sausalito, CA 94965

**(415) 332-7245**  
yachts@abcyachts.net

25 Third Street,  
San Rafael, CA 94901  
**(415) 457-9772**

CLAY & TERESA PRESCOTT • GEORGE HIGBIE • PHIL HOWE • LARRY MAYNE • DANA PAUL • ARNIE GALLEGOS • PETER BOHN • ED LABARRE • JOHN SAUL

## OUR BAJA HA-HA TOP FOUR CRUISERS

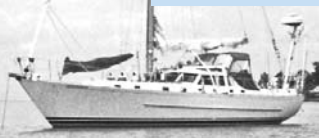

**48' C&C LANDFALL  
1980**  
\$135,000



**COUNTESS 44**  
Ketch rig, Alden design, raised salon, numerous upgrades. Pristine. \$99,500



**59' CUSTOM CB KETCH PH, 1978**  
Baja Ha-Ha in style.  
\$165,000



**51' ALEUTIAN, 1980**  
Cutter, center cockpit, great passagemaker and great price. \$159,900



**38' MORGAN, '84**  
\$55,500  
Also: '78...\$44,000

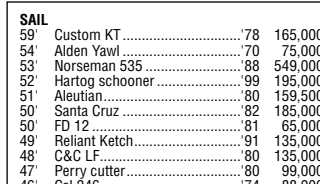

**CAPE GEORGE CUTTER 31, 2000**  
\$142,500



**35' BABAS**  
1979...\$69,500 • 1985...\$110,000  
Both moored near each other in Sausalito.

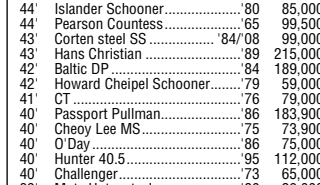

**36' UNION POLARIS, '78,**  
Cutter, diesel, Sausalito slip.  
\$79,000

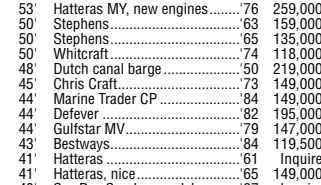

**35' J/105, 2001**  
\$125,000



**85' BROWARD, 1981**  
Aluminum. Mexico to Kodiak, Alaska. Meticulously maintained. Newer engines.  
\$940,000

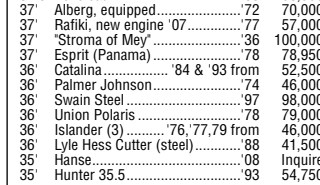

**HANSE 350, 2008**  
Already commissioned.  
Ready to go sailing.  
Inquire

SAIL		POWER	
59' Custom KT	78 165,000	31' Cape George Cutter	'00 142,500
54' Alden Yawl	70 75,000	30' Carabella cutter	'66 14,900
53' Norseman 535	88 549,000	30' Catalina (two)	'75 & '81 from 16,500
52' Hartog schooner	99 195,000	30' Islander	'74 & '75 from 15,000
51' Aleutian	80 159,500	30' Islander Bahama	24,000
50' Santa Cruz	82 185,000	30' Lancer	'80 32,500
50' FD 12	81 65,000	30' Golden Gate	'91 34,500
49' Reliant Ketch	91 135,000	29' Hunter 29.5	'94 33,500
48' C&C LF	80 135,000	28' Newport	'74 Cheap
47' Perry cutter	80 99,000	26' Alden	'33 11,000
46' Cal 246	74 88,000		
46' Lippincott	99 69,500	85' Broward Alum	'81 950,000
45' Columbia	72 69,500	67' Stephens Alum	'80 795,000
45' Downeast	77 89,000	65' Pacemaker, cert.	'71 299,000
45' Noble CC (steel)	'89/05 150,000	65' Elco Classic MY	'26 450,000
44' Norseman CC	84 225,000	57' Chris Craft	'65 135,000
44' Islander Schooner	80 85,000	53' Hatteras MY, new engines	'76 259,000
44' Pearson Countess	65 99,500	50' Stephens	'63 159,000
43' Corten steel SS	'84/08 99,000	50' Stephens	'65 135,000
43' Hans Christian	89 215,000	50' Whitcraft	'74 118,000
42' Baltic DP	84 189,000	48' Dutch canal barge	'50 219,000
42' Howard Cheipel Schooner	79 59,000	45' Chris Craft	'73 149,000
41' CT	76 79,000	44' Marine Trader CP	'84 149,000
40' Passport Pullman	86 183,900	44' Delfer	'82 195,000
40' Cheoy Lee MS	78 73,900	44' Gulfstar MV	'79 147,000
40' O'Day	86 75,000	43' Bestways	'84 119,500
40' Hunter 40.5	95 112,000	41' Hatteras	'61 Inquire
40' Challenger	73 65,000	41' Hatteras, nice	'65 149,000
39' Mota Huta, steel	80 29,000	40' Sea Ray Sundancer, dsl	'97 Inquire
38' Morgan	'78 & '84 from 44,000	40' Kha Shing	'81 98,000
38' Ingrid	'76 & '84 from 61,900	39' Mainship	'89 79,000
38' Hans Christian	'80 92,000	38' Holiday Mansion	'89 38,500
38' Morgans	'78 & '79 from 44,000	38' Chris Craft	'65 66,000
37.5' Beneteau	'85 68,900	35' Cooper Prowler	'86 78,000
37' Alberg, equipped	'72 70,000	34' Atlantic SF	'89 79,000
37' Rafiki, new engine '07	'77 57,000	34' Mainship	'81 48,000
37' 'Stroma of Mey'	'36 100,000	34' Sea Ray Sundancer, dsl	'01 155,000
37' Esprit (Panama)	'78 78,950	34' Kevlcat	'97 125,000
36' Catalina	'84 & '93 from 52,500	34' Tolly Craft (2)	'73 & '87 from 26,000
36' Palmer Johnson	74 46,000	32' Bayliner 3288	'89 54,900
36' Swain Steel	'97 98,000	32' Uniflite, v/d	'77 37,500
36' Union Polaris	'78 79,000	32' Silverton FB, 370 hrs	'98 55,500
36' Islander (3)	'76, '77, '79 from 46,000	30' Sea Ray	'88 29,500
36' Lyle Hess Cutter (steel)	'88 41,500	29' Boston Whaler	'98 98,000
35' Hanse	'08 Inquire	29' Monterey	'95 29,000
35' Hunter 35.5	'93 54,750	28' Boston Whaler, twin Merc	'99 59,000
35' Baba (2)	'79 & '85 from 69,500	28' Mako CC	'96 32,500
35' Fantasia Mk II	'79 25,000	28' Cruiser, nice	'86 28,000
35' Jason	'75 50,000	27' Seaport w/trailer	'96 90,000
34' C&C, nice	'80 37,500	26' Osprey long cabin	'03 85,000
34' Sabre	'83 46,000	26' Osprey	'02 98,000
34' J/105	'01 125,000	25' Albin	'75 26,000
34' Catalinas	'84 & '89 from 45,000	24' Chaparral, trailer	'94 19,000
33' Hans Christian	'86 112,000	24' Orca, inboard	'99 39,995
32' Targa, center cockpit	'78 34,500	24' Osprey	'96 69,500
32' Westsail	'77 & '79 from 48,500	22' Grady White 222 w/trlr	'02 59,000
32' Odyssey, nice	'67 75,000	22' Boston Whaler w/trailer	'04 40,000
32' Ericson, nice	'74 9,000	20' Shamrock	'05 25,000
32' Coronado	'73 26,000	19' Chris Craft Replica	'07 29,000
31' Pacific Seacraft Mariah	'79 69,000	17' Marlin, '91 w/OB, '02 w/trlr	29,500



**45' NOBLE CC, '89/05...\$150,000**  
Also: 36' SWAIN, 1997...\$98,000;  
43' CORTEN, '84, \$99k; 39' MOTA HUTA, '80, \$29k  
36' LYLE HESS, '88...\$41,500



**85' BROWARD, 1981**  
Aluminum. Mexico to Kodiak, Alaska. Meticulously maintained. Newer engines.  
\$940,000

See her at SAIL FEST  
Modern Sailing, Sausalito  
Sunday, September 28



SEVEN REASONS TO OWN A HANSE:  
EASE OF USE, SAFE, COMFORT, PERFOR-  
MANCE, QUALITY, STRENGTH & PRICE.

### Hanse Dealer Report

HANSE Regatta on Sept. 27 and 3 Hanses on display at Modern Sailing Academy's SAIL FEST from 11am to 5pm on Sept. 29.

See you there!

Larry R. Mayne – Yacht & Ship Broker  
Dealer & New Boat Sales Manager  
Sales dock slip available, \$300/month



# NORPAC YACHTS

1150 Brickyard Cove Rd., B9, Pt. Richmond, CA 94801  
**(510) 232-7200 • FAX (510) 232-7202**  
 email: [info@norpacyachts.com](mailto:info@norpacyachts.com)

**WE HAVE BUYERS & NEED MORE BOATS!**  
**LIST YOUR BOAT NOW & WE SHALL SELL HER!**

**FOR MORE  
 SEE OUR  
 norpacyachts.com  
 WEBSITE**

## KAY OF GÖTEBORG



**52' S&S YAWL** by Walsted of Denmark, '78. One of the finest vessels of her size & type. Copper riveted double TEAK, dsl, doradas, dodger. Best of everything in finest construction possible. Recently back from 15k miles singlehanded. Magnificent, elegant. Exquisite: the Ultimate Classic Yawl. **Ask \$500,000**

## ESTATE SALE



**58' LOD NEW ZEALAND SCHOONER.** 16'6" beam, strong, copper riveted, 3x kauri-planked. Detroit dsl, radar, AP, watermaker, genset, shower, 3 S/Rs. World cruiser. GREAT OPPORTUNITY! **Try \$75,000/Offers**



**58' STEEL SCHOONER.** 19th Century American Privateer Replica. New build & just sea trialed to Central America & back through hurricanes. 6-pack US, built for Caribbean Charter unlimited, more than fully equipped to stand alone at sea, stoutly built & quite exciting. **\$515,000 Ask**



**36' PICNIC BOAT.** Exceptionally high-quality, comfortable & luxurious performer. Dsl, absolutely loaded with equipment & can't be told from NEW! With Warranty. Already located in Vancouver, BC, Canada, for your cruising pleasure. Motivated seller! **Asking \$324,950**



**57' CHINESE JUNK.** Teak const. Huge & very comfortable well lit & well appointed inter. Outstanding liveboard cruiser w/lug rig & highly desirable Gardner dsl. Charm, character. Gen set, washer/dryer. Pos. liveboard slip & more! **\$133,950/Offers**



**27' BALBOA.** Ultra clean. Designed by Lyle Hess. Great pocket cruiser. Fast, roomy/comfortable. Well equipped w/inboard dsl engine, self-tailing Barlow winches, two-burner Force 10 stove, marine head, depth sounder, GPS, VHF radio, stereo, and an E-Z Loader trailer with surge breaker. Trailer sailing gives you a place to live on the road to the next sailing venue. **Cheap at \$12,750 Asking**



**36' 52' 11 Meter Sloop** An excellent vessel from a fine builder. 35hp inboard diesel Saildrive, galley, enclosed head with shower, pulpits and lifelines, well maintained, more! VERY NICE BOAT. **Asking \$47,950**



**45' COLUMBIA** Center cockpit sloop. Diesel, F/G, roomy, comfortable cruiser with good light and visibility below. Two heads, shower & MORE! These are great cruise/live vessels. We have two, starting at **\$28,500**



**52' GOLD COAST** Coastal Cruiser. Liveboard layout. Teak interior. Sleeps 7. Full size galley, side by side refrig/freezer, microwave, dishwasher, new carpeting, 2 heads (1 w/tub, 1 w/shower), dual helm stations. Nice second home/office? **Ask \$58,950**



**19' CHRIS CRAFT MAHOGANY RUNABOUT** with trailer. 2004 Replica of 1941 original in virtually new condition. GM Vortas 227 hp V8. Rare opportunity and easy maintenance. **Asking \$25,000**

**SAIL**  
 50' CAULKINS Slip. A project, but all there. Dsl, strip plank, ocean racer..... Try 15,000  
 43' SPARKMAN & STEPHENS steel custom cutter by Olin Stephens. Major upgrades. Center cockpit, aft cabin, new elect. syst., diesel and more. FULL REFIT NEARLY COMPLETED: BEAUTIFUL! ..... Asking 98,950  
 42' Sparkman & Stephens Performance Cruising Slip. Dsl, dodger, F/G, many upgrades & new rig..... Asking 48,950  
 39' FREYA Double-ender, steel, dsl, dink, a/b, new point, solar, furling, radar, AP, cruise equipped & more! ..... Asking 48,950  
 38' INGRID Ketch by Wm. Atkins. Great glass double-ended cruiser. Diesel, vane, furling, radar, EXTRA STOUT! Much recent upgrading. Let's go cruising! ..... Asking 60,950  
 37' VILLENAVE Cruising Ctr Blue Water Euro Performance. Loaded..... Asking 43,950  
 36' STEEL HARTOG ketch, double-ended cruiser. Great potential, reduced to 9,900  
 36' NIELSEN classic 1918 Danish aux. sloop. Diesel. Nice condition ..... Asking 15,000  
 36' SPARKMAN & STEPHENS Center Cockpit Cruising Slip. Dsl, F/G, wheel, ++ ... 24,950  
 35' CHEY LEE by Robb. Dsl, teak... 17,950  
 32' Fuji Ketch, dsl, furling, shower, cruising keel. Quality ..... Asking 31,950  
 30' YAMAHA Slip. Dsl, wheel, galley & head, solid performer. Clean & well built. Very nice below ..... Asking 13,000  
 30' Mk II, 1973. IOR 1/2-ton Britton Chance design. Great beginner, low maintenance performance boat, great cruising potential, 5 berths, standing headroom. Solid F/G hull, roller furler, diesel (Yanmar, has manual), VHF, D/S, W/P, W/S, K/M. 3 (4) headsails (135% & #4 gennies, 3/4 & 1.5 oz kites), spinnaker, main..... 14,000/obo  
 29' PEARSON TRITON. New diesel. Total refit nearly done ..... Asking 15,950  
 29' ERICSON Slip. Inboard ..... 7,000  
 27' BALBOA Sloop. Diesel auxiliary, wheel, standing headroom, 2-axle EZ-Loader trailer..... Asking 12,750  
 27' CHEY LEE Offshore. Dsl, GLASS, Classic Design & MORE! ..... Asking 9,500  
 26' MacGREGOR, 1999 26x Slip. w./tl, wheel, furling, 50 hp, ++ ..... Ask 17,500  
 25' CHEY LEE FRISCO FLYER, teak. 8,000  
 23' HERRESHOFF Classic PRUDENCE Sloop with 2003 Honda..... 7,500

**POWER**  
 130' CAMCRAFT Passenger Ship. Certified for 33 passengers overnight. Booked for the season. Virtual turnkey: Money and opportunity, working PNW..... 2,200,000  
 100' Steel HIGH ENDURANCE ADVENTURE/CHARTER SHIP & Business in Panama. Successful & turn-key operation and a great opportunity ..... Ask 2.25 mil USD  
 75' NORTH SEA Trawler. Exquisite yacht conversion. Gardner Dsl +++, lying PNW ..... Ask 825,000  
 60' MATTHEWS MY, '65, twin diesels, big, comfortable liveboard cruiser with South SF berth ..... Asking 215,000  
 45' STEPHENS 1929 classic. Beautiful Gatsby-era motor yacht waiting to transport you back to the days of yachting in the grand style..... Try 75,000  
 44' TRAWLER by Wm. Garden. Offshore beauty by the King of trawlers. A yacht of commercial quality, best wood construction ..... Asking 149,000  
 43' MATTHEWS, '65, diesel. A gem! Loaded and beautiful..... Asking 69,450  
 42' GRAND BANKS Tvl. Aft cabin, F/B, Onan, twin dsls, radar. Excellent..... 121,000  
 41' CHRIS CRAFT CONSTELLATION. Aft cabin. Great liveboard, full Delta canvas, new shafts, smooth running, dinghy w/outboard & MORE! Great potential! GREAT LIVEBOARD! REDUCED! Asking 12,950/obo  
 41' CHRIS CRAFT 410 Commander. F/G, roomy, great layout for liveboard... 49,000  
 37' DEFEVER TRAWLER by North Sea. Dsl, F/G, F/B, 2 heads, showers, radar, gen, thruster, GPS/map & MORE! Very nice... Ask 88,950  
 37' HATTERAS Convertible. One of their BEST EVER! Maj. refit just complete. Twin 8V53 dsls, 7.5 kw Onan, F/B. Loaded & outstanding..... 179,000/Offer  
 32' BOWPICKER, aluminum. Commercial (berthing) license..... 49,000  
 32' CARVER. Twin Gas Motors, 225 hp W/Y-drives. Dual steering stations, possible liveboard Sausalito berth. Unusually roomy for this size class, the Carvers are known for their good construction and creature comfort. Nice boat w/exquisite restoration. .... Ask 28,000  
 31' MONTEREY BAY EXPRESS PILOTHOUSE utility, F/G, '9e1, twin 130 Yanmars, trailer, USCG-documented, commercial quality gem. REDUCED! Asking 29,950  
 29' WELLCRAFT 2900 EXPRESS. Twin screw (not outdrives). Super clean & nice! Bright red ..... REDUCED! Asking 19,950  
 27' FARALLON Pilothouse, '86. F/G, twin 5L V8s, fast and seaworthy. Just detailed and very nice ..... Asking 51,950  
 26' PACEMAKER, cabin cruiser, V8, nice!... 8,500  
 24' WILSON w./tr. Twin Volvo 6 cyl. dsls, fwd cabin, encl. PH, radar, depth, Lorin. Ideal commercial quality fishing/diving boat w/new point & running gear! MORE! ..... 29,500

**MARINE INSURANCE**  
 CONTACT OUR EXPERT  
**ELDENE FLETCHER AT**  
[eldene@norpacyachts.com](mailto:eldene@norpacyachts.com)  
**(415) 235-5247**



**40' CHALLENGER Ketch.** Gorgeous, Sparkling Performance Cruiser in excellent condition. Dsl, furling, spinn., full galley, enclosed head & shower, hardwood interior, wheel, pedestal, full lifelines & pulpits, inverter, Avon & a/b. MUCH MORE! Shows pride of ownership. **Asking 64,000**



**58' ALDEN BOOTHBAY MOTORSAILER** center cockpit ketch. Dsl, genset, air/heat, new upholstery, much recent refitting & refinishing. Loaded w/cruising gear, AP, radar ++. Great comfortable bluewater cruiser w/excellent layout & more!! **\$268,950 Ask**



**100' MEGA SLOOP** Custom Offshore Performance Cruiser. Luxurious, spacious, comfortable, sleeps 25 in 17 bunks. Loaded w/amenities & equipment. Fast, Cummins dsl. Excellent condition. Great private yacht with super charter potential. World class cruising & MORE! **Try \$975,000 USD**



**32' GRAND BANKS CLASSIC TRAWLER, 1970** Economical diesel, dual helms, flybridge, TEAK decks, full electronics, swim platform, mast and boom. She's a great cruiser and a very well loved design. **\$24,950/Ask**



**31' PACIFIC SEACRAFT "Mariah" Cutter.** Strong FG Double-Ended World Cruiser by Crealock. Dsl, wheel, furling, dodger, RADAR & more! An outstanding vessel for everything from Bay sailing to Blue Water cruising. **Ask \$68,950**

**CALL (510) 232-7200 OR FREE (877) 444-5087**  
**OR CALL GLENN DIRECT AT (415) 637-1181**  
**FOR INFORMATION & INSPECTION APPOINTMENTS**



# ACRES – INDOORS AND OUT!



**Nelson's Marine has acres of space dedicated to handling whatever your boat needs:**

- Long Term Storage
- On Land Sales 'Slips'
- Indoor Paint Shed
- Outdoor Prep & Paint
- Full Service Repair & Restoration



**Well Cared For  
SPECIAL:  
\$33/ft!\***

\*A clean, well-cared-for boat always deserves special treatment – and special pricing. If you haul regularly and have a fair hull, you too many qualify for these 2002 prices! Call for details.



**32' UNIFLITE, 1976**

This classic twin engine cruiser is ready for the Bay and Delta. **\$24,400**



**41' AMEL SHARKI, 1980**

Outstanding reputation for safety and comfort in bluewater. Asking **\$70,000**



**HOLLMAN 50**

The ultimate turnkey cruising boat. One of a kind. **\$229,000**



**SACRAMENTO AFFILIATE: McClellan Indoor Boat & RV Storage**  
**(916) 640-0141 • www.mcclellanstorage.com**



**NELSON**  
*Yachts*

**Chad Freitas, Broker • (877) 517-8281**  
See ad page 232

**Sacramento  
Yacht Sales  
NOW  
OPEN!**

**Nelson's Marine**

**www.nelsonsmarine.com**  
1500 FERRY POINT  
ALAMEDA, CA 94501  
**(510) 814-1858 • FAX (510) 769-0815**