

Latitude 38

VOLUME 373 July 2008

WE GO WHERE THE WIND BLOWS

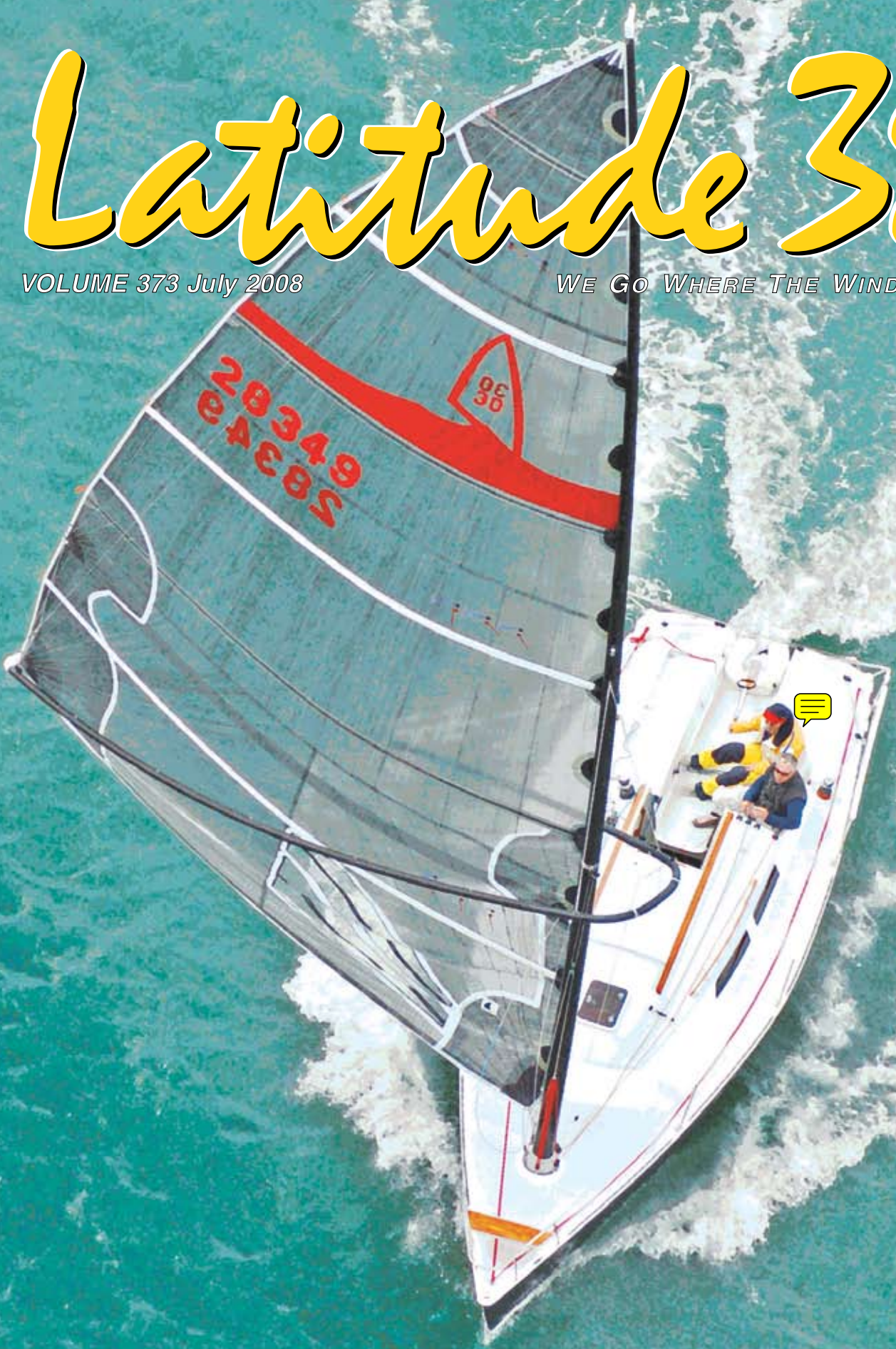

Latitude 38

JULY 2008

VOLUME 373



Come to Grand Marina for a weekend and leave with memories that last a lifetime.

We do our utmost to ensure our tenants and guests have the best experience possible - because the best is what they deserve.

Visit Grand Marina, the pearl of the Bay, for an experience of a lifetime.

- Over 400 concrete berths 30 to 60 feet
- Secured Gatehouses (electronic key system)
- Dockside Electrical (up to 50A - 220V)
- Cable TV & Telephone Service
- Heated & tiled restrooms with individual showers
- Beautifully Landscaped
- Ample Parking available
- Sailboat & Powerboat Brokers on site
- Excellent customer service
- Monthly informative newsletter

DIRECTORY of GRAND MARINA TENANTS

Bay Island Yachts	220
Bay Marine Diesel.....	219
The Boat Yard at Grand Marina..	12
Lee Sails	208
New Era Yachts.....	223
Pacific Coast Canvas.....	83
Pacific Yacht Imports	11

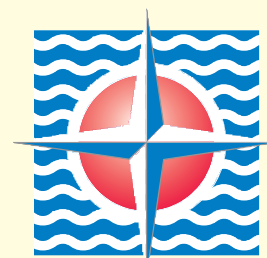

GRAND MARINA
ANDERSON-ENCINAL

510-865-1200

Leasing Office Open Daily
2099 Grand Street, Alameda, CA 94501
www.grandmarina.com

Our wait list for liveaboard status is now closed.

The Schooner 'Aldebaran'

Hayden Brown began building his schooner, *Aldebaran*, in 1971. But his idea of 'building' is quite different from most people's.

He not only built the hull, deck and interior, he built the box section wooden masts and spreaders.

He spliced, then wormed, parceled and served the standing rigging.

He built the blocks using oak cheeks with brass sheaves and bearings, all 93 of them.

He built the 14-foot-long tiller with a beautiful inlaid star.

He didn't do it all by himself. Friends helped. But he 'outsourced' almost nothing.

Except the sails!

In 1988, Hayden came to Pineapple Sails to provide the boat's 1,771 sq. ft. of working sail area, with a total complement of 13 sails. We were selected as Hayden's sailmaker because we care greatly how our sails come out. We pay attention to details, shapes, cloth selection, structures, and our customers' needs. We don't 'outsource' anything either! All of our sails are made from start to finish right here in Alameda, California.

How good do they come out? Hayden is still using the same suit of sails we built way back then! The above photo was taken in April of 2008.

If you want great sails that will last a long time, Pineapple Sails is still the right choice.



PHOTO: PETER LYONS WWW.LYONSIMAGING.COM

*Aldebaran**

YOUR DEALER FOR: Musto foul weather gear, Dubarry footwear and Headfoil 2

Sails in need of repair may be dropped off at:
West Marine in Oakland, Alameda, or Richmond;
or Svendsen's in Alameda.

*Powered by Pineapples



PINEAPPLE SAILS

Phone (510) 522-2200

Fax (510) 522-7700

www.pineapplesails.com

2526 Blanding Ave., Alameda, California 94501

Love at First Sight...

After sailing most of my life, and on the West Coast for more than 25 years, our needs in a sailboat evolved over time. Originally, we were purists when it came to sailing, i.e. out there in the elements. Then came the dodger, followed by the enclosed cockpit. When we saw Bob Johnson's design for the Island Packet 41' SP Cruiser, it was love at first sight.

The SP Cruiser takes the pilothouse design and creates a more functional sailboat. It offers two cockpits to enjoy the good weather in, and an inside steering station to get out of the weather. The pilothouse has great views and comfortable seating for six or seven people. The galley really works, and the storage in the boat is incredible.

When we first sailed the SP Cruiser, the boat handled superbly, and my wife was impressed with the ease of steering the boat in over 20 knots of wind. I was overwhelmed at the innovative technology that has been incorporated into the boat.

After experiencing the ownership of our SP Cruiser, Seeta and I know that we made the best decision in selecting Island Packet as the manufacturer of our dream boat and purchasing the boat from Passage Yachts. Both organizations mirror the outstanding quality of the boat with their exceptional servicing and support.

— Dirk & Sheeta Kridenier, *Shiva*, SP Cruiser 41



Island Packet SP Cruiser 41
Motorsailing redefined
New 2008 Model at our docks



With more than 25 new boat models, and a worldwide selection of used boats, your perfect match is just a call away.



ALERION 28' to 45'



BENETEAU 31' to 57'



ISLAND PACKET 37' to 50'



Demo Boat Closeout

Beneteau 343

Versatile family cruiser. Ready to sail away for \$129,000. Save \$30K.



Wauquiez 41 Pilot Saoon

Luxury performance cruiser. Save over \$60,000.



Beneteau First 10R

Fully race loaded: carbon rig and carbon sails. Save over \$50,000.



Only 5 pre-production slots left for the new **Island Packet 460** Center Cockpit. Save \$54,000. Fully refundable deposit holds your production slot.



Come meet the sales team at Passage Yachts



Klaus Kutz



Don Wilson



Jack Woida



Jim Long



Jim Tull



Chris Corlett



Torben Bentsen

Passage Yachts Brokerage...



BENETEAU 393, 2007 ~ \$189,500

Extremely clean recent trade-in:
A new boat at a used boat price.
Transferable warranty.



SEA RAY SUNDANCER 340, 2006 ~ \$189,500

Extremely clean trade-in. Loaded and ready for comfortable extended cruising: generator, AC, GPS, satellite stereo, flatscreen TV, wet bar, icemaker, etc.



ISLAND PACKET 320, 1991...\$88,000



BENETEAU 473, '04...\$274,900



CAPE DORY 36, '89...\$120,000



BENETEAU 423, '04...\$216,500



TAYANA VANCOUVER 42, '79...\$93,500



HUNTER 310, '86...\$22,000



PASSPORT 40...2 from \$118,000



SABRE 38, '05...\$321,900



BENETEAU 390, '90...\$98,500



BALTIC 37, '80...\$106,800



ISLAND PACKET 370, '04...\$299,000



BENETEAU 361...2 from \$119,000

EXPLORER 45, '79..... \$130,000
TARTAN 44, '75 89,000
BARNETT 42 CUSTOM, '86 135,000
CASCADE 41, '71 \$59,500

J/41, '85 Inquire
HUNTER 40.5, '96 99,000
CARROLL MARINE 1200, 95 85,000

BENETEAU FIRST 37.5, '85 69,000
BENETEAU 11.5, '85 63,000
BENETEAU 370, '91 83,000

BENETEAU 361, '00 119,000
GIB'SEA 33, '01 87,500
WESTSAIL 32, '76 39,000
TIARA 29, '98 94,500

BENETEAU ALERION EXPRESS CNB ISLAND PACKET WAUQUIEZ

OUR SERVICES: FINANCING FULL SERVICE DEPARTMENT CONCIERGE SERVICES



FOR THE TIME OF YOUR LIFE

**Pt. Richmond
Office**

1220 Brickyard Cove Rd
p: 510-236-2633
f: 510-234-0118

**Two
Locations!**

www.passageyachts.com ■ sales@passageyachts.com

**Alameda Office
Marina Village**

1070 Marina Village Pkwy
Suite 101
p: 510-864-3000
f: 510-337-0565

PUSSER'S®

*"The single malt of rum"
and the father of grog*



Farbest writes, "Pusser's is still made in the same way it was at the time of Trafalgar - in wooden pot-stills as opposed to modern industrial column-stills. This results in the most full-flavored rum available anywhere".



The original Navy Rum and the father of grog is the rum of the Royal Navy and Royal Marines for more than two centuries.



Gold Medal, London, 2001
San Francisco, 2003 & 2005



Pusser's isn't for everyone. Some people prefer rums that are almost flavorless when compared to the impressively rich flavor of Pusser's. But if you want a rum that you can enjoy sipping, or still taste through the mix of your favorite cocktail, then Pusser's is for you. Try a Pusser's and Calu sometimes and taste the difference.

Pusser's is not always easy to find but your local retailer can order it for you. Or take a look at HOW TO FIND IT on our web site at

www.pusser.com

Charles Tobin

Charles Tobin, Chairman

CONTENTS

subscriptions	10
calendar	22
letters	36
loose lips	96
sightings	100
carbon footprint	132
eye on the bay	144
pacific cup preview	150
marc and doreen	118
tall ships are coming	126
sss transpac preview	136
max ebb: squall of the wild	154
the racing sheet	160
world of chartering	174
changes in latitudes	182
classy classifieds	202
advertisers' index	215
brokerage	220

Cover: Lynx sails home from the Lightship.

Photo: Latitude/JR

Copyright 2008 Latitude 38 Publishing Co., Inc.

Latitude 38 welcomes editorial contributions in the form of stories, anecdotes, photographs—anything but poems, please; we gotta draw the line somewhere. Articles with the best chance at publication must 1) pertain to a West Coast or universal sailing audience, 2) be accompanied by a variety of pertinent, in-focus digital images (preferable) or color or black and white prints with identification of all boats, situations and people therein; and 3) be legible. These days, we prefer to receive both text and photos electronically, but if you send by mail, anything you want back must be accompanied by a self-addressed, stamped envelope. **Submissions not accompanied by an SASE will not be returned.** We also advise that you not send original photographs or negatives unless we specifically request them; copies will work just fine. Notification time varies with our workload, but generally runs four to six weeks. Please don't contact us before then by phone or mail. Send all submissions to editorial@latitude38.com, or mail to Latitude 38 editorial department, 15 Locust Ave., Mill Valley, CA 94941. For more specific information, request writers' guidelines from the above address or see www.latitude38.com/writers.html.



F A R A L L O N E

Finalize Your Dream...

Catalina Yachts



Worlds Largest Catalina Yacht Dealer!

We're Proud to Introduce



The Ranger Tugs!

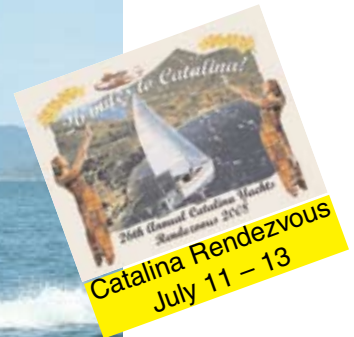

New Catalinas In Stock



San Diego Boat Show July 24 - 27

Preowned Sailing Yachts • 14 Assorted Dreams Sold in June!



Mikelson Cutter 50



Catalina 36 4 to choose from



Catalina 350 3 to choose from

Preowned Catalina Yachts

Catalina 42 mkl	2002	198,000
Catalina 380	1998	130,000
Catalina 38	1981	49,000
Catalina 36	2001	122,500
Catalina 36	1995	94,500
Catalina 36 mkl	1995	89,950
Catalina 36	1996	79,900
Catalina 350	2004	158,500
Catalina 350	2004	149,900
Catalina 350	2004	149,000

Catalina 34	2007	134,000
Catalina 34	2005	117,00
Catalina 34	2003	115,000
Catalina 320	2005	119,900
Catalina 320	2002	98,000
Catalina 320	1999	84,900
Catalina 320	1994	57,000
Catalina 30	1982	23,900

Open Boat Weekend July 11 - 12

Preowned Sailing Yachts

Mikelson Cutter 50	1988	275,000
Cavalier 45	1985	255,000
Franz Maas 42 PK	1972	135,000
Beneteau CC 36	2001	132,000
Lancer 45	1986	120,000
Jeanneau 36	1997	95,000
Hunter 34	1999	84,990
CS 34	1990	61,000
Morgan 38	1979	57,500
Hunter 290	2001	49,900
Hunter 30	1990	37,000

1070 Marina Village Pkwy. Alameda CA 94501 510 • 523 • 6730



2302 Shelter Island Drive San Diego CA 92106 619 • 523 • 6730

ALAMEDA • NEWPORT BEACH • SAN DIEGO www.faralloneyachts.com

Jeanneau



America's Most Popular Imported Sailboats



2008 Jeanneau 39i



2008 Jeanneau 42 Deck Salon



2008 Jeanneau 49i



2008 Jeanneau 45 Deck Salon

PRE-CRUISED SPECIALS

2001 Hunter HC 50 (Ocean Ready).....	\$449,000
2006 Hunter 45 Center Cockpit.....	\$329,000
2007 Hunter 44DS (Three Cabin).....	\$269,950
2005 Hunter 38.....	\$179,999
2004 Hunter 36.....	\$119,995
2003 36' Hunter 356.....	\$114,999
1983 43' C&C Landfall.....	\$109,995
2004 33' Hunter 33.....	\$99,950
1999 Hunter 310.....	\$55,000
1996 Hunter 280.....	\$39,777
1976 Pearson 26.....	\$7,900

Visit www.cruisingyachts.net for details.

Charter Ownership

Under the 2008 Economic Stimulus Act, you can **deduct up to \$250,000 on your personal income taxes** for boats purchased and placed in charter in 2008. See our website and contact us for details.

Call: 888-78-YACHT

Hunter



America's Best Selling Sailboats

We'll make your payments until April 2009 on all boats in stock!



Hunter Mid-Range Cruisers 31 – 38 Feet



Hunter Full –Size Cruisers 41-50 Feet



Mike Harker
*Cruises the World
in a Hunter 49*



Hunter Center Cockpit 45 Feet



Hunter Deck Salons 41 – 45 Feet

We Need Used Boats!

- We sell more boats 30' to 60' than anyone in the Bay area
- We'll take your boat in trade or sell it for you
- All makes and models
- Your boat will appear in the leading boat publications and websites
- Your boat will be displayed at our show dock

We'll make your payments until April 2009 on all boats in stock!

- Boats Open 7 Days a Week
- Top 5 Hunter Dealers 2007
- Top 10 Service Department
- Inhouse Financing Available
- We take trade-ins!



Cruising Yachts, Inc.

Alameda
888-78-YACHT
www.cruisingyachts.net

BOAT LOANS

from



Trident Funding

*"a fresh approach from
people you can trust"*

*In Northern California call
JOAN BURLEIGH
(800) 690-7770*

*In Southern California call
JEFF LONG
MARGE BROOKSHIRE
(888) 883-8634*

*In San Diego call
MIKE LOCKARD
(619) 255-5666*

www.tridentfunding.com

SUBSCRIPTIONS

Please read form carefully before submitting.

We regret that we cannot accept foreign subscriptions. Check, money order, or credit card information must accompany request. Please allow 4-6 wks to process changes/additions, plus delivery time.

Enclosed is \$18 for one year on eBook

Check out www.latitude38.com and click on eBooks to see what we're talking about. Our eBooks are now in PDF format, easy to use with Adobe Reader



Enclosed is \$36 for one year Third Class Postage

(Delivery time 2-3 weeks; Postal Service will not forward third class, so you must make address change with us in writing.)

Enclosed is \$55 for one year First Class Postage (Delivery time 2-3 days; FPO/APO (military), Canada & Mexico subscriptions are first class only)

Third Class Renewal First Class Renewal (*current subs. only!*)

Gift Subscription – Card to read from: _____

Name _____

Address _____

City _____ State _____ Zip _____

Phone: () _____ Email: _____

CREDIT CARD INFORMATION MASTERCARD VISA AMERICAN EXPRESS
Min. Charge \$20 Number: _____ Exp. Date: _____

INDIVIDUAL ISSUE ORDERS

Current issue = \$6.00 • With classy ad placed = \$5.00

Back Issues = \$7.00 (must indicate exact issue by month or vol. #)

DISTRIBUTION

We have a marine-oriented business/yacht club in California which will distribute copies of *Latitude 38*. (Please fill out your name and address and mail it to the address below. Distribution will be supplied upon approval.)

Please send me further information for distribution outside California

Business Name _____ Type of Business _____

Address _____

City _____ State _____ Zip _____

County _____ Phone Number _____

Latitude 38

"we go where the wind blows"

Publisher/Exec. Editor Richard Spindler richard@latitude38.comext. 111
Associate Publisher..... John Arndt..... john@latitude38.comext. 108
Managing Editor..... John Riise..... johnr@latitude38.comext. 110
Senior Editor Andy Turpin andy@latitude38.com.....ext. 112
Associate Editor LaDonna Bubak ladonna@latitude38.com.....ext. 109
Associate Editor Rob Grant rob@latitude38.comext. 105
Advertising Sales John Arndt..... john@latitude38.comext. 108
Advertising Sales Shawn Grassman..... shawn@latitude38.comext. 107
Classified Sales Mary Briggs class@latitude38.comext. 104
General Manager..... Colleen Levine colleen@latitude38.comext. 102
Production/Web Christine Weaver chris@latitude38.comext. 103
Production/Photos Annie Bates-Winship ... annie@latitude38.comext. 106
Bookkeeping Helen Nichols..... helen@latitude38.comext. 101

Directions to our officepress 4
Subscriptionspress 1,4
Classifiedclass@latitude38.compress 1,1
Distributiondistribution@latitude38.compress 1,5
Editorial.....editorial@latitude38.compress 1,6
Calendar.....calendar@latitude38.com
Other emailgeneral@latitude38.comWebsite: www.latitude38.com

Please address all correspondence by person or department name

15 Locust Avenue, Mill Valley, CA 94941 • (415) 383-8200 Fax: (415) 383-5816

Pacific Yacht Imports is Proud to Announce They Have Been Named Exclusive West Coast Dealers for Tayana Yachts



TAYANA 54 DS WORLD PREMIER AT OUR DOCKS



2005 TAYANA 48 DECK SALON

Like new with only 71 hrs on Yanmar. Raymarine electronics, air/heat, genset, Corian, LeisureFurl main, electric winches.

\$489,900



2005 TAYANA 48 CC

Like new and loaded. 500 hours on Yanmar 75 turbo. LeisureFurl, electric winches, KVH 33 Imarsat phone. **\$455,000**



1990 TAYANA 55

Original owner has kept her in bristol condition and loaded her with all the best. Immarsat, thruster, electric furling and primaries. **\$402,000**



1977 VALIANT 32 CUTTER

Classic Robert Perry design. Solid, basic platform to build your cruising boat and priced accordingly. **\$34,500**



1984 TAYANA V-42 aft cockpit cutter. Mast has new LPU paint, rigging & wiring. Raymarine pkg. incl. AP, radar, GPS plotter AGM batteries. Full cockpit enclosure, 3 genoas, spinn w/sock, extensive equip. list **\$149,500**



2000 BENETEAU FIRST 40.7. Race ready with many upgrades like larger motor, oversize primary winches, carbon spin pole, professionally faired. **\$189,000**



1988 HANS CHRISTIAN 41 Molokai In as fine a condition as one will hope to find in a yacht of this caliber. Fully equipped. **\$225,000**

Pacific Yacht Imports

2051 Grand Street, Alameda, CA 94501

www.pacificyachtimports.net

We're at Grand Marina

Dave Wolfe, Neil Weinberg, Keith Rarick

Tel (510) 865-2541 Fax (510) 865-2369

tayana@mindspring.com

THE BOAT YARD AT GRAND MARINA

Formerly Mariner Boat Yard

"Where Service Has Meaning"

Interlux
yachtpaint.com

AWLGRIP

**60-TON
TRAVELIFT**



FEATURING
TRINIDAD
ANTI-FOULING PAINT BY
PETTIT
marine paint
RATED "SUPERIOR" by
Practical Sailor

The only yard to brush on your bottom paint!

Dealers for:

MAX-PROP
AUTOMATIC FEATHERING PROPELLERS

GORI
marine

Webasto

PACKLESS SEALING SYSTEM
SHAFT SEAL

Lectra/san

SIDE-POWER
Thruster systems

facnor
FURLING SYSTEMS INC.

AQUAMARINE
FINE REVERSE OSMOSIS EQUIPMENT

IT'S SIMPLE!

Call The Boat Yard at Grand Marina for the Lowest Bottom Prices!

~ COMPARE US WITH THE COMPETITION ~

- Prop and Shaft Work
- Mast & Rigging Repair
- Fiberglass & Blister Repair
- Gelcoat Repair
- Gas & Diesel Engine Service
- LPU Hull & Topside
- Electrical Repair & Installation

CALL FOR A RESERVATION

(510) 521-6100 • Fax (510) 521-3684

Located at Grand Marina • 2021 Alaska Packer Place, Alameda

www.boatyardgm.com



5 Convenient California Locations
Open 7 Days/Week • We take TRADE-INS
#1 DEALER FOR JEANNEAU & HUNTER IN '07

888.325.4353
www.HSyacht.com



H&S SAILBOAT RENDEZVOUS AT CATALINA - JULY 17 - 20, 2008



1987 Hunter 28.5	\$19,000	1999 C&C 110	\$139,995	2005 Bavaria 42	\$184,900	2002 Hunter 466	\$249,900
1991 Hunter 28	\$29,000	2005 Hunter 36	\$139,900	2004 Hunter 420	\$234,500	1980 Island Trdr 46	\$210,000
2000 Hunter 290	\$59,000	2006 Hunter 36	\$145,000	2005 Beneteau 423	\$199,000	1999 Catalina 470	\$238,500
1991 Hunter 30	\$39,500	1993 Hunter 37.5	\$86,500	2003 Jeanneau 43DS	\$259,000	1984 Mayflower	\$149,000
2002 Hunter 326	\$79,000	1999 Hunter 380	\$89,000	1998 Hunter 430	\$157,000	2008 Hunter 49	\$425,000
2003 Hunter 326	\$77,900	1999 Hunter 380	\$95,000	2006 Hunter 44 DS	\$268,000	2007 Beneteau 49	\$432,900
1995 Catalina 320	\$79,500	1999 Island Pckt 38	\$250,000	2004 Hunter 44 DS	\$265,000	1993 Columbia 50	\$95,000
2003 Hunter 326	\$69,000	2004 Beneteau 393	\$162,000	1996 Beneteau 45	\$169,000	2000 Jeanneau 52.2	\$429,900
2005 Hunter 33	\$99,000	1994 Beneteau	\$134,500	1999 Hunter 45	\$179,000	1981 Pearson 530	\$249,000
2006 Hunter 33	\$118,000	2004 Hunter 41	\$229,900	2000 Hunter 45 CC	\$209,000	2005 Jeanneau 54DS	\$675,000
1996 Hunter 336	\$73,000	1999 Hunter 410	\$159,000	2000 Hunter 450	\$210,000	2001 Moody 54 CC	\$695,000
2001 Hunter 340	\$87,000	2000 Hunter 410	\$165,000	1998 Hunter 456	\$169,000	2005 Jeanneau 54DS	\$675,000
1981 Sabre Classic	\$55,000	1998 Hunter 410	\$132,500	1997 Hunter 450	\$179,000	2006 Jeanneau 54DS	\$740,000
1987 Catalina 34	\$53,000	2003 Beneteau 411	\$195,000	2000 Jeanneau 45.2	\$259,000	2004 Jeanneau 54D	\$660,000
1999 Hunter 340	\$89,000	2006 Hunter 41DS	\$229,900	2005 Hunter 46	\$290,000	1997 Jomar 55	\$299,000
2004 Hunter 36	\$148,000	2003 Beneteau 423	\$224,000	2006 J Boats 46	\$675,000		
2002 Catalina 36	\$119,900	1989 Catalina 42	\$115,000	2004 Hunter 466	249,000		

Visit HSyacht.com for daily updated listings!



SELL YOUR BOAT FASTER WITH H&S

WE SELL MORE 30'- 60' SAILBOATS THAN ANYONE!

- You'll have over 25 salesmen marketing your boat from 5 offices across Southern California.
- Your boat will appear on the leading boating websites, printed boating publications and at boat shows we attend.



SAN DIEGO | NEWPORT BEACH | MARINA DEL REY | CHANNEL ISLANDS



Successfully Selling Boats in Mexico since 1998

Looking to buy a boat to cruise south to Mexico or beyond? The boat you are looking for is either in Mazatlan or La Paz. These are proven, cruise ready boats, all have been outfitted, and all have made the trip from the U.S., Canada or other countries.

Fuel Prices Are Much Lower in Mexico!



Hunters ~ Eight to choose from, 34-ft to 54 ft



61' Nordlund Flybridge Cockpit, 1975 ~ \$199,900



38' Shannon Cutter, 1980 ~ \$109,900



52' DeFever Trawler, 1970 ~ \$135,000

Size	Brand/ Model	Year	Price	Size	Brand/ Model	Year	Price	Size	Brand/ Model	Year	Price
SAIL											
54	Hunter	1983	105,000	40	CS Sloop	2001	149,900	31	Brown Searunner Trimaran	1978	35,000
51	Hudson Ketch	1978	TBA	40	Valiant Sloop	1988	175,000	30	Newport Mk III	1984	16,500
51	Formosa Cutter Ketch	1974	138,000	40	Passport Sloop	1982	145,000	29	Bayfield Cutter	1978	25,000
50	Gulfstar CC Ketch	1979	139,000	40	Robert CC Sloop	1980	109,000	28	Bahama Sharpshooter	1950	39,500
49	Amazon Cutter	1988	300,000	39	Roberts 392 PH Steel Cutter	1993	165,000	27	Corsair F-27 Trimaran w/trailer	1991	50,000
47	Catalina 470 Sloop	2000	274,000	38	Hans Christian Cutter	1987	133,000	27	Vancouver Sloop	1977	49,000
46	Hunter 466 Cutter	2002	199,900	38	Roberts Ketch	1982	66,900	27	Catalina w/trailer	1973	12,000
46	Hunter 460 Cutter Sloop	2000	235,000	38	Shannon Cutter	1980	109,900	20	Pacific Seacraft Flicka	1978	25,000
46	Morgan 462 CC Ketch	1981	109,000	38	Hans Christian Traditional	1979	97,500	POWER			
46	Hunter 450 Passage CC	1998	219,000	38	Downeaster Cutter	1978	52,000	61	Norlund Flybridge Cockpit	1975	199,900
45	Hylas 455 Cutter	1995	230,500	38	Bluewater Ingrid Ketch	1974	50,000	60	Gladding & Hearn Pilot	1960	219,000
45	Island Trader CC Cutter Ketch	1979	142,000	37	Hunter Legend Sloop	1992	84,900	60	Lien Hwa Custom Classic	1980	330,000
44	Hylas Sloop	1991	229,500	37	Hunter Legend Sloop	1989	59,900	53	Hatteras Yachtfish Cockpit FB	1980	249,000
44	Irwin CC Sloop	1987	79,000	37	Pearson Sloop	1979	34,500	52	DeFever Trawler	1970	135,000
44	Kelly Peterson	1979	119,000	37	Hunter Cherubini Cutter	1978	59,500	48	Tollycraft Motoryacht	1976	199,900
43	Irwin Mk III	1989	TBA	37	Rafiki Cutter	1976	79,000	47	Santa Barbara Yachts	1964	75,900
43	Spindrift PH	1981	134,500	37	Tayana Cutter	1975	72,000	45	CHB Sedan Trawler	1981	169,000
43	Polaris Cutter	1979	110,000	37	Tayana Ketch	1983	89,900	43	Silverton Sport Bridge	2006	500,000
43	Nautor Swan Sloop	1969	89,900	36	Union Cutter	1980	46,500	42	Bertram Convertible	1985	180,000
42	Sabre Sloop	1986	167,500	36	Islander Sloop	1979	39,900	42	Californian Coastal Trawler	1979	119,500
41	Cooper US 42 PH	1981	100,000	36	Chung Hwa Magellan Ketch	1967	20,000	42	Grand Banks Trawler	1970	69,000
41	Seawind Cutter Sloop	1977	55,000	36	Cal Sloop	1970	35,000	40	Hatteras Convertible Sportfish	1968	95,000
41	Tartan T.O.C.K.	1976	103,000	35	Bristol Sloop (pending)	1986	39,500	39	Bayliner 3988	1998	165,000
41	Formosa Yankee Clipper	1974	92,500	34	Catalina Sloop	1985	44,500	39	Sea Ray Express	1989	80,000
41	Formosa CT Ketch	1974	64,900	34	Hunter Sloop	1980	TBA	32	Blackfin Combi w/charter	1989	125,000
41	Morgan OI CC	1974	TBA	34	C&C Sloop	1984	59,500	32	Uniflite Sedan Sportfisher	1977	28,900
41	Tartan Sloop	1973	85,000	32	Freedom Sloop	1979	TBA	28	Precision 2800 Flybridge Sportfish	1994	45,000
41	Pearson Rhodes Bounty II	1966	59,000	32	Morgan Custom Sloop	1978	31,000	28	Skipjack Sportfisher	1984	55,000
40	Custom by Robert Perry	2003	TBA	32	Downeaster DE 32 Cutter	1979	68,000	23	Custom Launch	1988	12,200
				31	Pacific Seacraft Mariah Cutter						



Ray Watson & Jeannette Sarrasin
 Toll free US/CAN: 1 (888) 716-7430
 Phone & FAX: 011 52-(669)-913-3165
 E-mail: Mazmarine@aol.com
 Compare our listings at: Mazmarine.com

Mike Rickman & Shelly Rothery Ward
 Toll free US/CAN: 1 (877) 245-9689
 Phone: 011 52-(612)-123-1948
 Cell: 011 521-(612)-105-6459
 E-mail: LaPazYachts@aol.com





Hans Christian



Flying Cloud Yachts

Sail • BROKERS • Power



6400 Marina Dr., Long Beach, CA 90803

Phone (562) 594-9716 Fax (562) 594-0710



NEW 105Mc - GEMINI, 2008
Best selling cruising catamaran in the U.S.!
\$162,500



47' GIL'S CHOY CATAMARAN, 2002
Ready to cruise the South Pacific today!
Everything as new, fully equipped. \$395,000



49' HANS CHRISTIAN CHRISTINA, 1986 Center cockpit, three cabin Peterson design. Exceptional condition. Only 49' on the market. \$268,000



54' HUNTER SLOOP, '81 New Yanmar diesel. Upgraded & equipped for cruising. Redesigned transom, keel. \$125,000. Also a 45' Hunter, '99.



55' ROBERTS C/C SLOOP, 1981
Great blue water cruiser. New Yanmar diesel, 3 staterooms. Call for details. \$235,000.



46' CAL CRUISING PH SLOOP Highly customized, 85hp Perkins, genset, electric furl main, beautiful condition in & out. \$99,500



41' NAUTOR SWAN, 1973
Clean and ready to sail. New LP and new bottom paint in 5/07. \$95,000



40' NORTH AMERICAN SLOOP, '79
Perkins diesel, almost everything is new, tons of upgrades! Call for details. \$69,000



36' ISLANDER SLOOP, 1981
Meticulously maintained! New Universal diesel, new upholstery. Many upgrades. \$59,000

Web site: www.yachtworld.com/fcyachts • email: flyingcloud@verizon.net



50' CELESTIAL PH SLOOP
2 stations, rebuilt 8kw gen., 108hp diesel, davits and more. \$250,000/offers



57' BOWMAN KETCH, 1978
Five hours on rebuilt 110hp Perkins. New electronics. Top-quality bluewater cruiser. \$249,000



42' WESTSAIL CUTTER, 1974 Only 400 original hours on 85hp Perkins. Great liveaboard with beautiful interior. A must see! \$99,500



43' CONTESSA SLOOP, 1978 Performance cruiser designed by Doug Peterson. Quality construction. Must see! \$139,000



36' CATALINA SLOOP, 1987
Many upgrades. Very clean, nicely equipped. \$54,500



41' YORKTOWN CENTER COCKPIT SLOOP, 1985. Nice liveaboard or cruise. 2 boat owner, give away price. \$39,500



41' TARTAN SLOOP, 1974. Stoutly built ocean racer with refurbished decks and 140 hours on 38hp Yanmar diesel. \$59,900.



38' HANS CHRISTIANS 1980-1986
From \$99,000



CATALINAS FOR EVERY BUDGET
30', 34', 36'.



32' DOWNEAST, 1976
Clean pocket cruiser. Low hours on new Volvo diesel! \$37,000



34' CAL CRUISING SLOOP, 1976
New Universal 24 hp diesel with only 200 hours, radar, GPS. \$48,500.



34' TUNG HWA DIANA CUTTER, 1983
Strong, traditional cruiser, new bottom paint, Perkins diesel. \$65,000



40' CARROLL MARINE TRIPP 40, 1991 "VOODOO." *Sailing World's* Boat of the Year People's Choice Award. \$64,900



40' CHOATE, '79 New Yanmar diesel in '97, low hours, new fuel tank, sleeps 9. Great racer or fast cruiser. \$47,500



33' HUNTER 336, 1996
Exceptionally large aft double cabin. Very clean, fractional rig. \$74,000



27' NOR'SEA SLOOP, '78
Center cockpit, new galvanized trailer, new Yanmar diesel, Aries windvane. \$45,000

Some boats shown may be sisterships.

We Still Offer More!



Making boating easier – and more fun! – is what a marina should be all about. That's why Oyster Cove Marina rates number one with many Bay Area boaters. It's an exclusive yet reasonable facility of 219 berths, accommodating pleasurecraft in slips up to 60-ft long. **Oyster Cove is the private Peninsula marina closest to bluewater boating.** Want to cruise to Sausalito, lunch at Tiburon, or sail to Angel Island? How about a day's fishing outside the Gate, or a weekend at the Delta? No other private Peninsula marina is better situated or offers nicer, fresher surroundings.

OYSTER COVE MARINA

385 OYSTER POINT BOULEVARD #8A,
SOUTH SAN FRANCISCO

(650) 952-5540

- Berths 30 feet to 60 feet
- Double Finger Concrete Slips
- Telephone Available
- Five Minutes from SFO
- Heated Dressing Rooms & Showers
- Laundry Room
- Nightly Security Patrol
- Complimentary Ice
- Cable TV/High Speed Internet
- Recently Dredged
- End Ties Available at \$5.75/Ft!

10% OFF TOTAL INVOICE*

Summer Savings

Haulouts for Bottom Painting AND ALL YARD SERVICES

Interlux.
yachtpaint.com

*Must present this coupon for work scheduled by July 31, 2008.



NEW MARINE DIESELS

Perkins DIESELS 10% OFF

SALES SERVICE PARTS

GENUINE PERKINS PARTS

Mention this ad ~ Good until 7/31/08

Perkins Authorized Master Service Dealer

We ship worldwide!

BRITISH MARINE



& INDUSTRIAL

#11 Embarcadero Cove
Oakland, CA 94606

**(800) 400-2757
(510) 534-2757**

Two blocks from West Marine

www.britishmarine-usa.com

KISSINGER CANVAS

Marine Canvas & Interiors
STEVEN KISSINGER

(925) 825-6734

Covering the Entire Bay Area



- Biminis
- Boat Covers
- Cushions
- Sail Covers
- Headliners
- Awnings

DODGERS

Side handrails and window covers included.

OPTIONS

Aft handrail, dodger cover, sailing bimini.

Free Estimates and Delivery

**Valiant 42
In Stock • Call for Appt.**

Valiant  Yachts



Where do you want to go?

*Serious cruisers who sail the oceans of the world choose Valiant to take them there.
Call Ballena Bay Yacht Brokers to learn more about the true performance cruisers.*



VALIANT 50...NEW!



42' NORDIC TUG, 2008...CALL NOW!



34' PACIFIC SEACRAFT...\$95,000



44' PETERSON, 1977...\$119,000



41' COOPER P.H., 1981...\$95,000



39' FAIRWEATHER, 1989...\$140,500



**BALLENA BAY
YACHT BROKERS**



**BALLENA BAY
YACHTS...
THE PROVEN CRUISING
SPECIALISTS**

**1150 Ballena Blvd. #121, Alameda, CA 94501 ♦ (510) 865-8600 ♦ Fax (510) 865-5560
2736 Shelter Island Drive, San Diego, CA 92106 ♦ (619) 523-1151
♦ www.ballenabayyachts.com ♦ www.trawlers.com ♦ www.yachtworld.com/ballenabay ♦**



Check our Web sites for other fine listings!

YACHTFINDERS

WINDSEAKERS

(619) 224-2349 • Toll Free (866) 341-6189

2330 Shelter Island Dr. # 207
 San Diego, CA 92106
 info@yachtfinders.biz
 www.yachtfinders.biz



45' HARDIN CC KETCH, '81 \$149,000
 This classy, solid, offshore vessel with graceful lines and a very open interior layout will take you safely around the Bay or around the globe.



44' PETERSON CC, '78 \$115,000
 Here's a yacht that's ready to sail, with a great rig, hull and engine. Inside she is bright and airy with white Corian countertops in the galley.



44' BENETEAU OCEANIS 440, '96 \$132,800
 This is the perfect Oceanis, extremely well fitted for offshore sailing, with a redundancy of systems, simple sail plan, and great ground tackle.



43' GULFSTAR CC SLOOP, '79 \$84,900
Leanore provides the cure for those in need of visiting far-away places. You'll need to add some equipment, some food, and choose a destination.



41' FORMOSA SEA TIGER, '72 \$59,000
Odyssey is the quintessential cruiser with enormous interior living space. An excellent choice for those enchanted with the traditional styles.



39' BENETEAU 39.3, '03 \$169,500
Opportunity is a stable, comfortable cruiser offering performance and Beneteau reliability. CE-rated Class A for unlimited offshore sailing.



37' HUNTER LEGEND 37.5, '87 \$57,900
Miller Time II is an absolutely pristine, well equipped sailboat. Take advantage of her racing prowess or go out coastal and pleasure cruising.



36' CATALINA, '87 \$56,500
 This desirable family cruiser, in unmolested original condition, is ready for custom outfitting. Her competitive price makes her a sure winner.



36' ISLANDER, '74 \$34,900
 The roomy above deck, the ease of sailing with the family, and the performance offered around the buoys all make this Islander a great choice.



34' CATALINA, '87 \$52,900
 Extremely clean and well-maintained Catalina 34 with many quality upgrades. Transferable live-aboard slip with marina approval! Priced to sell!



32' CATALINA 320, '94 \$65,000
 This fine example of the Catalina 320 is in great condition and well priced. With the space and comfort of a larger vessel, she's hard to beat.



30' RANGER, '78 \$19,500
 Here's the only Ranger 30 for sale on the West Coast! Priced right, with new topsides and new stainless hand rails. She looks and sails like new!

BayRisk Classic

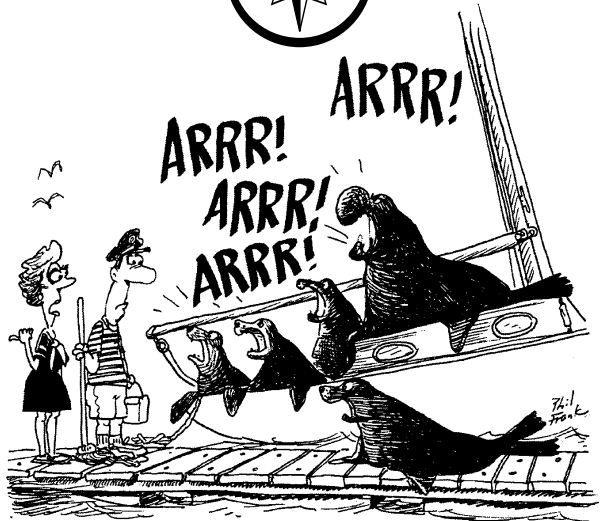

"I'll get the BayRisk policy."

BayRisk Insurance Brokers, Inc.

800-647-2025

Visit our Website www.bayrisk.com

1920 Minturn Street • Alameda, CA 94501



Catalina 320, *Four Winds*

STARBUCK



CANVAS WORKS

...Unless You
 Just Don't
 Care.

67 Liberty Ship Way
 Sausalito, CA 94965

415-332-2509

BAJA HA-HA XV

BROUGHT TO YOU BY THESE OFFICIAL SPONSORS



Turn the page for more →

WWW.BAJAHAHA.COM

The Rally Committee encourages you to patronize the
advertisers who make this event possible.

We already have more than
67 boats registered!



Vallarta Yacht Club

Your Yacht Club South of the Border!

Where the winds are moderate, the water's warm, and the sailing's Fun!

Home of the Banderas Bay Regatta

Cruiser friendly with everything you need from a full service yacht club.

Visit us at www.vallartayachtclub.org

Nautical Books, Software, Charts
and more



WAYPOINT

www.waypoints.com

info@waypoints.com • (510) 769-1547

WE SPEAK SSB



Radio • Email • More

www.hfradio.com

info@hfradio.com • (510) 814-8888

ICOM

Icom America Inc.

Award-winning Marine Communications Equipment

Handhelds • Mounted VHF • SSB • Radar

Visit one of our many West Coast dealers

www.icomamerica.com/marine

Head south with Scanmar, the Official Self-Steering Gear of Baja Ha-Ha XV

BUILT LOCALLY
USED GLOBALLY
PROVEN FOR DECADES



MONITOR
INNOVATION

auto-helm

Saye's Rig

SOS Emergency
Rudder

www.selfsteer.com

FACTORY DIRECT

SCANMAR INTERNATIONAL

432 South 1st Street

Pt. Richmond, CA 94804

Tel: (510) 215-2010

Fax: (510) 215-5005

Toll Free: 888-WINDVANE (946-3826)

email: scanmar@selfsteer.com

Summer
is safe at
Paradise..



Paradise Village

BEACH RESORT & SPA • MEXICO

Enjoy
your stay
with us!

011-52-322-22-66728 • www.paradisevillage.com

marina@paradisevillagegroup.com

Making Fresh Water, Worldwide.™



SPECTRA
WATERMAKERS™

Most energy efficient • Push button operation
Quick & easy installation • Low maintenance

(415) 526-2780

www.spectrawatermakers.com

RIGGING ONLY

Standing and running rigging, lifelines, furlers, winches,
headsail poles, main slider systems, windlasses,
travelers, wire terminals, blocks and more...
Expert advice for selection and installation.

Our 24th
Year!

(508) 992-0434

www.riggingonly.com

Mexico Cruising Insurance

Blue Water Insurance

(866) 463-0167 • (619) 226-6702

Fax: (866) 795-3707

Mexico full or part-time • Crew of two

www.bluewaterins.com

BAJA HA-HA XV

BROUGHT TO YOU BY THESE OFFICIAL SPONSORS

WWW.BAJAHAHA.COM



MARINA NUEVO VALLARTA
Bahía de Banderas, Nayarit
NOW UNDER CONSTRUCTION
230 Mooring Spaces from 22' to 130' Long
15-year long term lease available
Contact Dockmaster: Juan Sebastian Estrada
Ph/Fax from US: **011 52 322 297 7000**
juan@marinanuevovallarta.com
www.marinanuevovallarta.com

Number One in Quality & Safety
LED NAVIGATION LIGHTS
by
WWW.SOLIDSTATEMARINE.COM
(415) 286-4520
Made in Marin County, California



GERRY
CORTEZ CHARTS
NAVIGATION CHARTS - CRUISING GUIDES
TIDE TABLES - LIGHT LISTS
GPS POINTS
www.gerrycruise.com



Let Marina El Cid
Welcome You to Mexico
A Cruiser's Paradise!
www.elcid.com
qcevallos@elcid.com.mx
011-52 (669) 916-3468



MARINA RIVIERA NAYARIT
AT LA CRUZ
The best marina - 25 minutes away from Puerto Vallarta
Tel: **322 779 91 91** or **329 29 555 26**
info@marinarivieranayarit.com
www.marinarivieranayarit.com

ARE YOU READY TO HA-HA?

Although the start of Baja Ha-Ha XV is still a few months away, it's high time to start making your plans for this year's event, which officially begins October 27.

As we often explain in these pages, the Ha-Ha is a 750-mile cruisers' rally from San Diego to Cabo San Lucas, with stops along the way at Turtle Bay and Bahía Santa María.

Prospective entrants should be clear that this offshore sailing event definitely *is not* a hand-holding service for those incapable of making this trip on their own. However, it is a fabulous opportunity to get acquainted with hundreds of like-minded cruisers as you 'cruise-in-company' along the Baja coast.

A new twist this year is that potential entrants may now sign up online at www.baja-haha.com. At this writing, 141 boats have begun the sign-up process and 63 have fully entered. You'll also find complete event details on the site.

Shortly after registering, entrants will receive their official event burgee by mail, along with special offers from the sponsors listed here.

Ventura Harbor Boatyard, Inc.

Located halfway between San Francisco & San Diego
Haulouts to 165 tons ~ Full line of marine services
Dockside services ~ On-site chandlery
1415 Spinnaker Drive, Ventura, CA
(805) 654-1433 • www.vhby.com



Not just a marina - a cruiser's community
Your best destination across the Sea...
www.marina-mazatlan.com
011-52 (669) 916-7799
elizarraga@marinamazatlan.com

'Electronic Latitude Official Electronic Host
Latitude We Go Where
the Wind Blows

See *'Electronic Latitude* at
www.latitude38.com

OPEQUIMAR

MARINE CENTER CENTRO MARINO
A Full Service Boat Yard in Puerto Vallarta
88 ton Travelift • Parts • Service • Repairs
011-52 (322) 221-1800 www.opequimar.com
info@opequimar.com

Almar Marinas

The West's Finest

www.almar.com



The Rally Committee encourages you to patronize the advertisers who make this event possible.

ULTRA ANCHORS - The quickest setting, highest holding power anchors available for you, your family and your vessel's safety.

Marine Products from the World to the USA



QuicklineUSA

15561 Computer Ln. #A, Huntington Beach, CA 92649
714-843-6964 714-843-6906 fax

www.quickline.us or info@quickline.us

TOTAL YACHT WORKS & C&C MARINE SERVICES

In **MATZATLAN'S NEW FULL-SERVICE BOAT YARD.** We can do it all. Mechanical Repairs. Paint. Glasswork. Rigging. And more.
TotalYachtWorks@hotmail.com
ccmarineservices@hotmail.com



"We Fix What Won't Work."



FULL SERVICE MARINA

New breakwater • New docks

Tel: 011-52 (612) 122-1646

Fax: 011-52 (612) 125-5900

email: marinalapaz@prodigy.net.mx

www.marinadelapaz.com



MAKING WATER DRINKING WATER

Watermakers that improve the cruising lifestyle.

(800) 755-6701

marine@katadyn.com

0D36887

Serving Boaters Since 1959



Cruise with Confidence

See Our Half-Page Ad In This Issue

(800) 992-4443

www.marinersinsurance.com

Newport Beach, CA • San Diego, CA
Burlingame, CA • Seattle, WA
Bradenton, FL • Puerto Vallarta, MX

IMPORTANT DATES

Aug 9 — Pre-Ha-Ha Gathering & Potluck Barbecue at Two Harbors, Catalina, 5-9 pm.

Sep 10 — Final deadline for all entries.

Sep 10 — Mexico-Only Crew List and Baja Ha-Ha Party, Encinal YC in Alameda; 6-9 pm.

Oct 19 — Ha-Ha Welcome to San Diego Party, Downwind Marine, 12-4 pm. Ha-Ha entrants only.

Oct 25 — Informational Meeting about the Pacific Puddle Jump, West Marine, San Diego, 5 pm.

Oct 26, 9 am — Final deadline for all crew and skipper waivers, West Marine, San Diego.

Oct 26, 11 am — Skipper's meeting, West Marine, San Diego. Skippers only please.

Oct 26, 1 pm — Ha-Ha Halloween Costume Party and Barbecue, West Marine, San Diego.

Oct 27, 11 am — Start of Leg 1

Nov 1, 8 am — Start of Leg 2

Nov 5, 7 am — Start of Leg 3

Nov 7 — Cabo Beach Party

Nov 10 — Awards presentations hosted by the Cabo Marina.



THE CRUISER'S CHANDLERY

www.downwindmarine.com
info@downwindmarine.com

(619) 224-2733 • Fax (619) 224-7683

The southbound cruiser's source for **EVERYTHING!**

Can't Wait to Outfit?

Use our website to order early!



The Travellers Mailbag

SINCE 1979

Travelling anywhere? Let us forward your mail.

(415) 332-2032

www.travellersmailbag.com

3020 Bridgeway, Sausalito, CA 94965



Professional yacht brokers located in the heart of San Diego's boating community. Specialists in cruising sailboats for 26 years

info@yachtfinders.biz • www.yachtfinders.biz

866-341-6189 • 619-224-2349

Fax (619) 224-4692

San Diego's Newest Marina

Pier 32 Marina

800-729-7547

office@pier32marina.com

www.pier32marina.com



West Marine

We make boating more fun!™

Call 1•800•BOATING

(1•800•262-8464)

for a catalog or the store nearest you.

Baja Ha-Ha Inc.

c/o 15 Locust Ave.

Mill Valley, CA 94941

WWW.BAJA-HAHA.COM

There is no phone number for the Baja Ha-Ha. And please don't phone Latitude 38 with questions, as the Ha-Ha is a completely separate operation.

FAR-OUT GENNAKER SAILING...

Now available
in carbon!

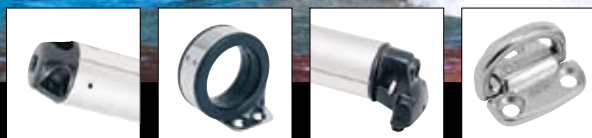

...with an extendable
Seldén gennaker bowsprit

- Gives the gennaker more clear air
- Facilitates rapid gybing
- Always ready for quick extension
- Makes for fast and efficient gennaker handling
- Can be fitted to most yachts
- Complete kit for deck mounting

www.seldenmast.com

 **SELDÉN**
for sailing

Rig solutions for dinghies, keelboats and yachts. Aluminium and carbon spars. More than 750 authorised dealers worldwide.

Seldén Mast Inc. Tel 843-760-6278, info@seldenus.com

CALENDAR

Non-Race

July 2-30 — Wednesday Yachting Luncheon Series at St. Francis YC, 12-2 p.m., \$13.50. Enjoy lunch and a dynamic speaker every Wednesday. All YCs' members welcome. More info under the 'Events' tab at www.stfyc.com.

July 2, 16 — Pt. Fermin Singles Sailing YC invites singles to two monthly meetings. 6 p.m. at Acapulco Restaurant in San Pedro. Info, (310) 427-4817 or www.pfsyc.com.

July 4 — Celebrate Independence Day at Barron Hilton's Fireworks Extravaganza at Mandeville Tip in the Delta.

July 4, 27 — Cal Sailing Club will give free sailboat rides at Berkeley Marina, 1-4 p.m. Info, www.cal-sailing.org.

July 6-27 — Free sailing at Pier 40 every Sunday courtesy of BAADS. Info, (415) 281-0212 or www.baads.org.

July 7 — Tactics & Weather seminar for Singlehanded TransPac at Encinal YC, 7:30 p.m. Info, www.sfbaysss.org.

July 10 — Single sailors of all skill levels are invited to the Single Sailors Association monthly meeting at Oakland YC, 6:30 p.m. Info, www.singlesailors.org or (510) 233-1064.

July 11-13 — 26th Annual Catalina Rendezvous at Catalina Island. Register online at www.catalinayachts.com.

July 13 — Master Mariners' Wooden Boat Show at Corinthian YC, 10 a.m.-4 p.m. \$10, kids under 12 free. Surf on over to www.mastermariners.org for details.

July 17-20 — H&S Sailboat Owner Rendezvous at Catalina's Two Harbors. Info, www.hsyacht.com.

July 18 — Full moon on a Friday night.

July 19 — Maintenance Tips for DIYers meeting at Oakland YC, 9:30-11:30 a.m. Info, (530) 522-6868 or cwong@oaklandyachtclub.com. \$3 fee covers handouts.

July 19 — Nautical Swap Meet at Ballena Isle Marina in Alameda, 8 a.m.-noon. Info, (510) 523-5528.

July 23-27 — Festival of Sail presented by the SF Maritime National Park Association. Greet tall ships from all over the world as they sail under the Gate on their way to Hyde St. Pier on the Cityfront. Info, www.festivalofsail.org.

July 30 — Storm Strategies with John Connolly at GGYC, 7 p.m. Free to Modern Sailing Academy and GGYC members, \$15 for non-members. Info, www.modernsailing.com.

July 30-Aug. 11 — *Niña*, the replica of Christopher Columbus's ship, will be visiting Sacramento's Old Town L Street Dock after the Festival of Sail, 9 a.m.-6 p.m. \$3-5.

July 31-Aug. 3 — Beneteau Owners Rendezvous at Catalina's Two Harbors. Info, www.southwesternyachts.com.

Aug. 2 — Flea Market & Maritime Celebration at Galilee Harbor in Sausalito, 8 a.m.-6 p.m. Info, (415) 332-8554 or www.galileeharbor.org.

Aug. 7-9 — 36th Annual Lake Tahoe Concours d'Elegance. Info, www.laketahoekoncourse.com.

Aug. 9 — Pre-Ha-Ha Rendezvous and Potluck BBQ at Two Harbors, Catalina Island, 5-9 p.m. at the bandstand. A super casual opportunity to meet organizers and other Ha-Ha'ers in advance. There will be a digital slide show, Q&A session and plenty of room on the barbie. Info, www.baja-haha.com.

Aug. 14-20 — *Niña*, the replica of Christopher Columbus's ship, will be visiting Loch Lomon YC in San Rafael, 9 a.m.-6 p.m. \$3-5.

Aug. 22-24 — 21st Annual Metal Boat Festival in Bellingham, WA. Info, www.metalboatsociety.org.

Aug. 30 — 18th Annual Vallejo YC Flea Market, 9 a.m.-?? "If it's legal, sell it!" Info, (707) 643-1254.

Sept. 9-25 — Boating Course by Marin Power & Sail Squadron in Novato on Tues. and Thurs., 7-9 p.m. Textbook \$50. Info, (415) 924-2712.

The New Catalina 375

The Closer You Look, the Better it Gets!



Understanding Needs and Dreams

Catalina listens to active owners and sailors and builds boats that reflect the collective wisdom and experience from thousands of cruises and sea miles.

Catalina's design is evolutionary, building on the success of previous models by incorporating many favorite, proven features into a contemporary, refined yacht. Graceful proportions, excellent performance, handling and a comfortable, beautiful interior make the 375 a proud addition to the Catalina fleet.



The bulkhead-mounted folding table is standard

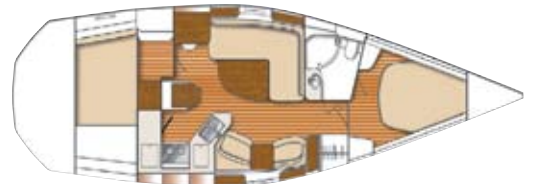

The "L" shaped settee and pedestal table is an available option

The new 375 continues the Catalina tradition of building honest, sturdy boats that hold up well in the real world. This means less maintenance and excellent resale value for 375 owners.

Better because...

- Interiors crafted with teak cabinetry and trim with a natural varnish finish for beauty and durability
- Keels cast in lead with stainless steel bolts for greater stability and less maintenance
- Oversized deck hardware and rigging for offshore reliability
- Large fuel, water and holding tanks for extended cruising range
- Powerful sail plans with inboard shrouds and generous genoa tracks for good performance
- Wide weather decks and tall life lines for easy passage forward
- Cavernous, easily accessible storage
- Logically engineered mechanical, electrical and plumbing systems
- A real live aboard interior with a large usable head and shower and a great galley with lots of storage
- A 40 hp. Yanmar diesel for excellent cruising speed under power
- CE category "A" (the highest certification)
- A 37 footer with a hull length (not just overall length) of over 37 feet



Reach for new horizons with the new
Catalina 375. Visit your nearest dealer today.

Catalina // Yachts
The Sailors' Choice

95% First Time Pass Rate
100% Satisfied Students



U.S. Coast Guard approved
courses and testing.
Approved for Veterans.

Captain's License

6 Pack/100 TON
Towing & Sailing

THE NEXT LEVEL OF EDUCATION

Advanced Training with over
30 College Accredited and
U.S. Coast Guard approved courses.

Boat Owners • Cruisers • Crew
Take the same Captains course offered to
professional mariners, and get advanced
training in safety, navigation, radar, radio and
rules of the road. The training everyone needs.

RADAR • RADIO • NAVIGATION • SAFETY

MARITIME INSTITUTE

6-PACK ONLY Weekend
Classes Start Soon!



CALL TOLL FREE 888-262-8020

OR visit our website for more information.

www.MaritimeInstitute.com

Also offering the full list of
International Yachtmaster® Training Courses

CALENDAR

Sept. 30-Oct. 20 — Safe Boating Course by Santa Clara Power Squadron at Wilcox HS on Tuesdays, 7-9 p.m. Materials \$30. Info, (408) 225-6097.

Racing

July 3-7 — El Toro NAs on Huntington Lake. Info, www.eltoroyra.org.

July 4 — 41st Annual Marina del Rey to San Diego Race. Info, www.smwyc.org or www.southwesternyc.org.

July 4 — Brothers & Sisters Regatta, a low-key lap around the two island groups followed by a BBQ and shoreside fun for the whole family. TYC, www.tyc.org.

July 4 — Firecracker Regatta. CYC, www.cyc.org.

July 5 — New Boreas Race, Half Moon Bay to Moss Landing, Elkhorn YC and HMBYC. Info, Luc at (831) 566-2009.

July 5-6 — BAYS #3 Youth Regatta and Smythe/Bemis Area G Qualifier. PYSF, www.pysf.org.

July 6 — Independence Day Regatta on Lake Merritt in Oakland, LMSC. Beth Buddington, (510) 444-5292.

July 7-13 — U.S. Junior Women's Doublehanded Championship hosted by Sausalito YC. Nearly 40 of the top doublehanded junior women teams in the nation will sail the Bay in 420s. Info, www.syconline.org.

July 10-13 — Santa Cruz 27 Nationals. RYC, www.richmondyc.org.

July 10-13 — Junior Olympic Sailing Festival, California YC. Rick Turner, (310) 641-0506 or rturner148@earthlink.net.

July 11-13 — 45th TransTahoe Regatta, generally featuring either too much wind or too little but always lots of fun. Tahoe YC, www.tahoeyc.com.

July 12 — 30th anniversary Singlehanded TransPac from SF to Hanalei. Come watch the start off Corinthian YC. Info, www.sfbaysss.org.

July 12 — Hart-Nunes for Merces. SFYC, www.sfyf.org.

July 12-13 — Moseley Regatta. TYC, www.tyc.org.

July 12-13 — Silver Eagle Long Distance Race, with a shorter course for boats rating 150 or above. IYC, www.iyc.org or call Joanne at (510) 521-7442.

July 12-13 — High Sierra Centerboards on Huntington Lake. Fresno YC, www.fresnoyachtclub.org.

July 14-19 — 15th Biennial Pacific Cup. For details on the race and parties, visit www.pacificcup.org.

July 16-20 — Governor's Cup, int'l junior match racing championship. Balboa YC, www.balboayachtclub.com.

July 18 — 2nd Annual Guardsmen Regatta (part of CYC's Friday Night Race) is a fundraiser for at-risk youth organizations. Info, www.guardsmen.org or (925) 240-7759.

July 19 — Plastic Classic, for fiberglass boats from the '60s & '70s, BVBC. Peter McCool, (415) 864-4334.

July 19-20 — Albert T. Simpson Sportboat Regatta. StFYC, www.stfyf.com.

July 19-20 — High Sierra Keelboats on Huntington Lake. FYC, www.fresnoyachtclub.org.

July 19-20 — PICYA Lipton Series, the annual interclub all-star game. GGYC, www.picya.org.

July 19-20 — West Wight Potters Roundup on Monterey Bay. MPYC, www.mpyc.org.

July 20 — Women's Regatta on Lake Tahoe. Tahoe YC, www.tahoeyc.com.

July 21-23 — Ultimate 20 NAs on Huntington Lake, Fresno YC. Info, (831) 336-9345 or www.u20class.org.

July 24 — Laser NAs. StFYC, www.stfyf.com.

July 25-27 — Santana 22 Nationals hosted by Santa Cruz YC. Info, www.scyc.org or (831) 425-0690.

Santa Cruz
— Y A C H T S —

FAST is Fun!

And a whole lot more.



New SC 37



KERNAN DESIGN			
SC 37 SPECIFICATIONS		SC 43 SPECIFICATIONS	
LOA	37.00 ft	LOA	43.00 ft
LWL	34.75 ft	LWL	41.07 ft
Beam	10.64 ft	Beam	12.00 ft
Draft	7.50 ft Std.	Draft	10.00 ft Std.
	6.00 ft Shoal	Displacement	12,750 lbs.
Displacement	8,514.00 lbs.	Ballast	6,050 lbs.
Ballast	3,930.00 lbs.	Limit of Positive Stability	143.00°
Limit of Positive Stability	142.00°	Sail Area	998 ft²
Sail Area	717 ft²		

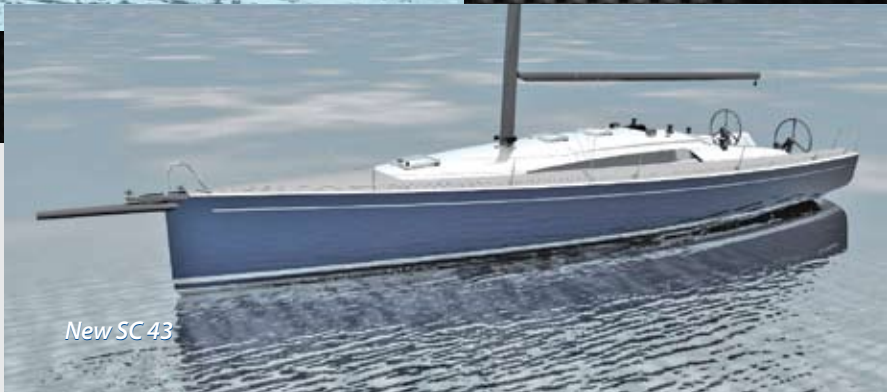

New SC 43

- Strong 100% Carbon Hull and Deck*
- Innovative Lifting Keel*
- Computerized Construction Techniques*
- Modern Eye Catching Styling*
- Race or Cruise-Fast!*

Presenting the new SC 37 and SC 43. We've taken state of the art technologies usually reserved for high priced custom boats and brought them all together to create yachts like no other company can build. Our cutting edge technologies give you stellar performance, more value and a lot more easy sailing fun.

Whether it's around the buoys, racing to Hawai'i or Bermuda, or just going to spend more time at that special anchorage with family and friends-sail fast, sail fun with a Santa Cruz.

Newport Beach
251 Shipyard Way,
Cabin A
Newport Beach, CA 92663
sailcaljt@aol.com
949-675-8035

Dealer for Santa Cruz Yachts in California

SAIL
California

Alameda
1070 Marina Village
Parkway #108
Alameda, CA 94501
info@sailcal.com
510-523-8500

www.santacruz-yachts.com

www.sailcal.com

AeroStructural Coupling



Infrared Heat

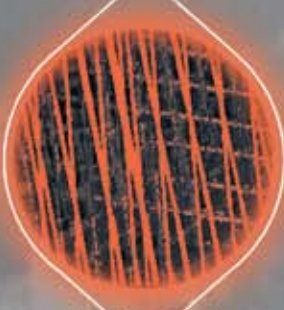

Intense Pressure



Cross Linked Molecular Structure



Post-Cured Shaping

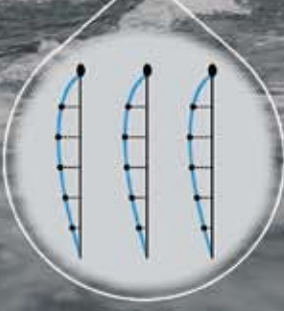

Quantum Seattle
Bob Pistay & Jon Henderson
6319 Seaview Ave. NW
Seattle, WA 98107
206.634.0636

Quantum Pacific
Jeff Thorpe & Don Teakell
1230 Brickyard Cove Road
Point Richmond, CA 94801
sanfrancisco@quantumsails.com
510.234.4334

YOU DON'T HAVE TO BE AN

Team Aqua, RC 44 World Champion, demanded serious science from its sailmaker. **1** Quantum computationally marries rig with sail for a perfectly-fused foil continuum. **2** Infrared radiation provides the precise heat necessary to use advanced adhesives without melting film. **3** Vacuum bagging shrink wraps film around yarns, then 6 tons of

Quantum Los Angeles
Mike Taylor
222 West D Street
Wilmington, CA 90744
mtaylor@quantumsails.com
310.518.2842

Quantum Long Beach
Todd & Nancy Wheatley
714 Marina Drive
Seal Beach, CA 90740
562.799.7444

Quantum San Diego
2932 Canon Street
San Diego, CA 92106
mreynolds@quantumsails.com
619.226.2422

EINSTEIN TO BUILD FAST SAILS. OR DO YOU?

www.teamAQUA.org

ANTICIPATE THE SHIFT

pressure insures bonding and squeezes out extra adhesive.

④ Thermo set process's polymerized, cross-linked molecular structure means less glue and better sheer strength. ⑤ Shaping after lamination, not during, avoids distortion due to shrinkage and insures repeatability. — There's a little Einstein in every Quantum Sail.

FUSION



QUANTUM SAIL DESIGN GROUP

Introducing the ALL NEW J/105!



U.S. Watercraft, the premier One-Design builder in the U.S., is now building the J/105 in addition to Farr 40s, J/24s and J/22s.

With the class being stronger than ever all across the country, many long-time owners expressed an interest in refreshing their 105s. Working with the owners, J Boats came up with a wish list from everyone who was psyched about staying in the class long term. The goal is to deliver a race-ready boat that will continue to keep the class at the front of One-Design racing for years to come.

The boat will come standard with:

- Totally faired keel and rudder ready to race.
- Minimum weight with factory weight certificate, Sparcraft One-Design anodized spar package.
- Racing mainsheet (fine-tune forward of traveler).
- LED Running lights.
- European-style galley unit.

First New J/105 here in time for
BIG BOAT SERIES

SAIL
California

Web page: www.sailcal.com
Email: info@sailcal.com

SAIL CALIFORNIA
NEWPORT BEACH
251 Shipyard Way
Cabin A
(949) 675-8053
FAX (949) 675-0584

SAIL CALIFORNIA
SAN FRANCISCO BAY
1070 Marina Village Pkwy,
#108, Alameda
(510) 523-8500
FAX (510) 522-0641

SAIL NORTHWEST
SEATTLE
7001 Seaview Ave., NW
Suite 140
(206) 286-1004
FAX (206) 286-1353

CALENDAR

July 26 — H.O. Lind #3 & #4, TYC. Otto, (415) 388-9094 or pando@sonic.net.

July 26-27 — YRA 2nd Half Opener. EYC, www.yra.org.

July 27 — Jack & Jill Race. SSC, www.stocktonsc.org.

July 1978 — It Was Thirty Years Ago, from the article *Superb Sailors* by Marilyn Yolles:

There's probably no better-liked champion on San Francisco Bay than Hank Easom. Easom is what America is all about, or used to be anyway. He's hard-working, straightforward, level-headed, inventive, unaffected, and as good as his word.

Winning is not the most important thing to the 43-year-old skipper, although Hank is totally committed to racing — "I admit it, it's an obsession. But I'm out there to have fun. I'd rather sail with old friends than red hot professionals." (Of course, it helps that Easom's crew has raced with him for more than a decade.)

Easom's been sailing since he was seven. In those days, during World War II, there were no junior sailing programs. Kids' sailing was not promoted like it is today. But Hank, by age 10, was entering small boat races with his brother and he's been racing on the Bay ever since. "I'm a bore," he said. "I've never done anything else. I do enjoy competitive tennis but, other than that, I play with boats."

Hank has accumulated enough local knowledge over the past 35 years to be one of the best. His experience, combined with an even-tempered disposition, make him a consistent winner.

"It helps to sail more than one day a week. For many years, I commuted to work in my boat — still do once in awhile. I feel better when I'm out there than I do in here," he said, glancing around his Sausalito office. "I go sailing to get away from the garbage."

Easom's face is tanned and deeply etched by the sun, making him look older than his years. The eyes are blue-blue, his hair is sandy. The large, rough hands look like they've seen a lot of work. In the boatyard, he appears relaxed, despite the heavy schedule. He ambles through surveying the activity — repairs mostly — with a knowing eye. The yard has as good a reputation as the man. "Sailing got me into this business. The boatyard makes it all possible," he says appreciatively.

By "it" he means, of course, the racing. About 60 races a year, primarily on Yucca, the 8-meter he has campaigned successfully for 12 years, winning seven Lipton Cup trophies, and last year the San Francisco Cup aboard Frank Gerbodi's *Oli-Oli*. Easom wins time after time, and always with grace.

"I get up on a race morning and I feel good. I look around, check the cloud cover. There's a pattern to San Francisco Bay through each season. If it's a hot day, it's probably not going to blow too hard," said the seat-of-the-pants sailor. "Am I the driver? I pay the bills, I'm going to drive the boat."

"Preparation is the biggest thing. All gear has got to be working. We don't break down very often — you've got to finish to win."

What's Easom's advice to other sailors? "You've got to keep your eyes open and adapt to changing situations. Listen to the crew. Be able to admit you're wrong or change your mind. Some people have a game plan, which I think is great, but they can't adapt to a wind change — the better sailors do."

Easom is flexible yet steady. The kind of guy you can count on when things go wrong. He sees no reason for a skipper to lose his temper. He is frankly irked by flashy young hot shots with braggadocio. He'd rather be quietly on the money.

"Hank's a superb human being," said Jocelyn Nash. "He has a good marriage and nice kids. He's great at what he does,

WE WANT TO SELL YOUR BOAT! CALL TODAY – DOCK SPACE AVAILABLE!

SAIL *California*

Your go-to dealer for performance boats and top of the line cruising boats, we represent *J/Boats, Santa Cruz Yachts, Sabre, and Back Cove Yachts.*

J/120, 2001

QuiB5

One of North America's most successful Big Boat One-Design, the J/120 is the most versatile 40 footer afloat. See QuiB5 on our sales dock. Asking **\$239,000**



Andrews 56, 1994

Charisma

This performance cruising boat offers speed and comfort with the allure for adventure. Call today to fulfill your cruising dreams. Asking **\$364,599**



45' Hunter 450, 2000

Fall Asea

Priced to sell, ultimate cruiser/live-aboard. Palatial interior (standing headroom over 6.5'), large cockpit, great swim platform, spacious decks. Ready for year-round fun. Asking **\$209,000**



SYDNEY 36,

2006

Encore

Call today to see this Sydney 36 CR. This boat has many 'trick' accessories and is truly a racer/cruiser. Asking **\$325,000**



Sabre 30, 1986, Buena Vida

This versatile, roomy, 30-ft boat is the nicest, cleanest boat you'll find. She's going to go fast, so see her on our sales dock today. Asking **\$59,000**



Express 34, 1987

The perfect small racer/cruiser. Asking **\$68,900**



J/105, 2001, Anna Laura

Race ready or weekend daysailer, the J/105 is the boat for you. Asking **\$119,999**



Melges 32, 2007, Stewball

Superior racer with a BIG high performance attitude. For much fun and excitement take a sail on the wild side! Asking **\$124,900**

56' Andrews 56, '92, <i>Cipango</i>	\$389,000
56' Andrews 56, '94, <i>Charisma</i>	Reduced! \$364,599
48' Kristen, '01, <i>Trinity</i>	\$629,000
45' Hunter 450, '00, <i>Fall Asea</i>	Reduced! \$209,000
44' J/44, '90, <i>Phoenix</i>	Reduced! \$219,000
41' Passport, '90, <i>360</i> **.....	New Listing \$289,000
41' Bianca 414, '80, <i>Avion</i>	\$58,000
40' J/120, '98, <i>Simply Red</i> *.....	\$199,000
40' J/120, '98, <i>Hot Tamale</i>	SOLD \$199,900
40' J/120, '95, <i>Attitude</i> *.....	Reduced! \$189,000
40' J/120, '01, <i>QuiB5</i>	\$239,000
40' Tripp, '92, <i>Snake Oil</i> *.....	Reduced! \$85,900
39' Dehler 39, '03, <i>Wild Redhead</i> **.....	\$329,500
38' Island Packet 38, <i>Sea Breeze</i>	\$134,900
37 Beneteau First 375, '85, <i>Time Warp</i> **.....	\$69,900

36' J/109, '03, <i>Queen Bee</i>	\$215,500
36' Sydney, '06, <i>Encore</i>	\$325,000
35' J/105, '02, Hull #523, <i>Streaker</i>	\$139,000
35' J/105, '01, Hull #403**.....	\$115,000
35' J/105, '01, Hull #382, <i>Anna Laura</i>	\$119,999
35' J/105, '99, Hull #265, <i>Tiburon</i>	\$109,900
35' J/105, '99, Hull #255, <i>Roadster</i> **.....	Reduced! \$105,000
35' J/105, '99, Hull #235, <i>Life Is Good</i> **.....	Reduced! \$92,900
35' J/105, '98, Hull #174, <i>Dulcinea</i> **.....	New Listing \$89,500
35' J/35C, '92, <i>Encore</i>	\$99,900
35' J/35, '85, <i>Aja Minor</i> **.....	Pending \$55,000
35' J/35, '84, <i>Courageous</i> **.....	SOLD \$42,000
35' One Design, '98, <i>Double Trouble</i>	\$94,900
34' J/34, '85, <i>The Zoo</i> **.....	Reduced! \$29,900

34' Express, '87.....	New Listing \$68,900
34' Pacific Seacraft, '89, <i>Credence II</i>	Reduced! \$94,500
32' Melges, '07, <i>Stewball</i>	Reduced! \$124,900
30' J/92, '93, <i>Zippy, Waukesha, WI</i>	\$54,500
30' Sabre, '86, <i>Buena Vida</i>	New Listing \$59,000
29' J/29, '81, <i>Macs</i> *.....	\$26,900
29' J/29, '84, <i>Jolly J</i> *.....	\$25,000
29' Back Cove, <i>Island Chef</i> *.....	\$199,000
29' Back Cove, '05, <i>Diamond Lil</i>	\$199,000
29' Cobalt 29, '01**.....	\$76,000
27' Choate, '79, <i>Allegro Con Brio</i> **.....	Reduced! \$9,900
26' J/80, '00, <i>Risky Business</i> **.....	Reduced! \$32,000
22' J/22, '88**.....	SOLD \$14,000
22' Aquapro Raider 665, '04.....	\$44,900

**OPEN BOAT WEEKEND
JULY 12-13**



* Indicates So. California Boats
** Indicates Seattle Boats

YACHTWORLD.com

SAIL *California*

Web Site: www.sailcal.com
Email: info@sailcal.com

NEWPORT BEACH
251 Shipyard Way
Cabin A
Newport Beach, CA 92663
(949) 675-8053
FAX (949) 675-0584

ALAMEDA
1070 Marina Village Pkwy
#108
Alameda, CA 94501
(510) 523-8500
FAX (510) 522-0641

SEATTLE
SAIL NORTHWEST
7001 Seaview Ave. NW
Suite 140
Seattle, WA 98117
(206) 286-1004



**West Marine®
Rigging Service**

Summer's Here!

Is Your Boat Ready?

From outfitting traditional cruisers to fine-tuning cutting-edge racers, let West Marine's experienced staff design the ultimate package to optimize the performance and look of your boat. Custom rigging is available through any West Marine store location.

POWERLITE
PRO RIGGING



NEW ENGLAND ROPES

SAMSON

HARKEN®

Marlow®

**SCHAEFER
MARINE**

RONSTAN

Hayn Marine

LEWMAR®

F FORESPAR®

- **PowerLite PBO**
- **Running Rigging**
- **Standing Rigging**
- **Dock & Anchor Lines**
- **Lifelines**

Contact us at 888-447-RIGG, or visit our Onsite Rigging Locations in:

Alameda

730 Buena Vista Av.
Ph 510-521-4865

San Diego

1250 Rosecrans St.
Ph 619-255-8844

Seattle

1000 Mercer St.
Ph 206-292-8663

CALENDAR

yet humble."

And, we might add, appreciative. Said Hank, "We have the greatest bay in the world. The best scenery and the best wind. You can get anything you want, any weather. We've got the world by the tail."

Aug. 1-2 — 36th Annual King Harbor to Santa Barbara Race. SBYC, www.sbyc.org.

Aug. 1-3 — Aldo Alessio Perpetual Trophy Regatta for IRC, J/120s, J/105s and any other big boat one design class that fields six boats. StFYC, www.stfyc.com.

Aug. 2 — Dinghy Ditch Run, 31 miles from Rio Vista to West Sac. LWSC, www.lwsailing.org.

Aug. 2 — Lady and the Tramp doublehanded race on Folsom Lake. FLYC, www.flyc.org.

Aug. 2-8 — 2008 Snipe Jr. & Sr. National Championships hosted by RYC & Fleet 12 SF. Info, www.snipenationals2008.com, vincesail@aol.com or (510) 841-8524.

Aug. 9 — YRA-OYRA Lightship 2. GGYC, www.yra.org.

Aug. 9 — YRA-HDA ODCA Fall 1. RYC, www.yra.org.

Aug. 9 — Gracie & George Regatta, a co-ed doublehander featuring 'Gracie' on the helm. EYC, www.encinal.org.

Aug. 9 — Joan Storer Regatta, TYC's women skipper's race. Info, www.tyc.org.

Aug. 9-10 — Summer Keelboat Regatta & J/105 PCCs. SFYC, www.sfyc.org.

Aug. 16-17 — BAYS #4. SFYC, www.sfy.org.

Aug. 23 — Single- and doublehanded Half Moon Bay Race, from SF to HMB. SSS, www.sfbaysss.org.

Aug. 23 — Inaugural Great San Francisco Schooner Race, for schooners of all sizes in Gaff and Marconi divisions. SFYC, www.sfy.org.

Aug. 29-31 — Express 27 Nationals. StFYC, www.express27.org or www.stfyc.com.

Sept. 5-7 — Moore 24 Nationals. RYC, www.richmondyc.org.

Sept. 11-14 — 44th Rolex Big Boat Series, always the highlight of the local sailing season. StFYC, www.stfyc.com.

Summer Beer Can Regattas

BALLENA BAY YC — Friday Night Grillers: 7/11, 7/25, 8/8, 8/22, 9/5, 9/19, 10/3, 10/17, 10/31. Dan or Kelly, race@bbyc.org.

BAY VIEW BOAT CLUB — Monday Night Madness Spring Series: 7/21, 8/4, 8/18, 9/1, 9/15, 9/22. Peter McCool, (415) 864-4334 or bayviewracing@sbcglobal.net.

BENICIA YC — Thursday nights July-September. Bill Watson, (707) 746-0739 or bill@watsonparty.com.

BERKELEY YC — Every Friday night through 9/26. Tom Nemeth, (510) 652-6537 or tom.nemeth@there.net.

CAL SAILING CLUB — Year-round Sunday morning Lido 14 races, intraclub only. Ed, racing_chair@cal-sailing.com.

CORINTHIAN YC — Every Friday night through 9/5. Donal Botkin, www.cyc.org/race or (415) 435-4771.

COYOTE POINT YC — Wednesday nights through 10/8. Roger Anderson, (650) 367-7480 or regatta@cpyc.com.

ENCINAL YC — Summer Twilight Series, Friday nights: 7/18, 8/1, 8/15, 9/5, 9/19. Tom Wondolleck, rearcommadore@encinal.org.

GOLDEN GATE YC — Friday nights: 7/11, 7/25, 8/8, 8/22, 9/5. Gary Salvo, (916) 363-4566 or garysalvo@ggyc.com.

HP SAILING CLUB — El Toro races on Stevens Creek Reservoir. Every Wednesday night through October 22. See www.hpsailingclub.org for details.

ISLAND YC — Summer Series, Friday nights: 7/25, 8/8,

TO GET OUT THERE...



COME VISIT HERE!

**OPEN BOAT
WEEKEND**



**JULY
12 & 13**

*If sailing the Bay or ocean on a new or brokerage vessel is
your dream, visit the sales docks at Marina Village.*

- *Better Brokers*
- *Better Boats*
- *Better Service*

MARINA VILLAGE

Much More than Just a Marina

www.marinavillageharbor.com

(510) 521-0905



CALENDAR

Slip Into Someplace Comfortable

Silicon Valley's newest and most convenient marina



Discover a touch of Italy with the quickest access to South San Francisco Bay. Bair Island's management team is committed to providing a truly excellent home for your boat.

- ★ Slips and side-ties from 30' to 75'
- ★ 30 and 50 amp power
- ★ Cable TV, DSL and phone
- ★ Calm, quiet and protected
- ★ Free parking
- ★ Heated shower and laundry facilities
- ★ Walk to shops, restaurants and movies
- ★ Office open 7 days
- ★ Dock boxes with lighting
- ★ Kids playground

BAIR ISLAND MARINA



702 Bair Island Road
Redwood City, CA 94063
650-701-0382
www.greatslips.com

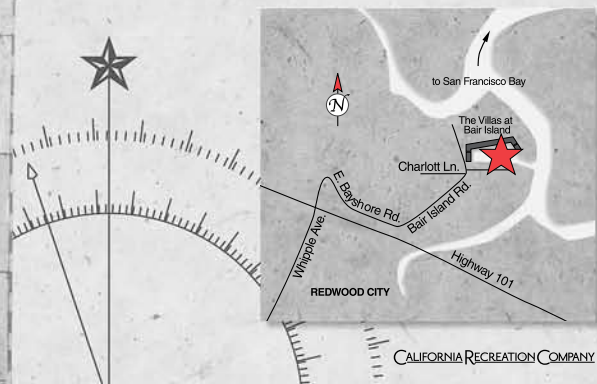

8/22, 9/12, 9/26. Joanne McFee, (510) 521-7442.

LAKE TAHOE WINDJAMMERS YC — Every Wednesday night through 10/29. Mike Robinson, (530) 713-9080.

LAKE WASHINGTON SC — Every Thursday night through 8/28. Roy, (530) 908-7160 or www.lwsailing.org.

MONTEREY PENINSULA YC — Sunset Series, Wednesday nights through 9/24. Bob Furney, (831) 372-9686.

OAKLAND YC — Sweet 16 Midweek Series, Wednesday nights 7/30-9/17. Steve, (510) 373-3280 or 5103733280@grandcentral.com.

RICHMOND YC — Wednesday nights: 7/2, 7/9, 7/16, 7/23, 7/30, 8/6, 8/13, 8/20, 8/27, 9/3, 9/17. Eric Arens, (510) 841-6022 or www.richmondyc.org.

ST. FRANCIS YC — Every Wednesday night 7/31-8/27. John Craig, (415) 563-6363.

SAUSALITO YC — Summer Sunset Series, Tues. nights: 7/29, 8/12, 8/26, 9/9, 9/23. Paul Adams, (415) 269-1973 or race@syconline.org.

SEQUOIA YC — Every Wednesday night through 10/8. Rick Gilmore, (650) 593-5591.

SOUTH BEACH YC — Friday Night Series: 7/18, 7/25, 8/1, 8/15, 8/22. Info, nashsherry@comcast.net.

STOCKTON SC — Every Wednesday night through 8/27. Phil Hendrix, (209) 476-1381.

TAHOE YC — Summer Series, every Wednesday night through 8/27. Summer Laser Series, every Monday night through 8/25. Dan Hauserman, (530) 583-9111 or dan@ilovetahoe.com.

TIBURON YC — Friday nights through 8/29. Otto, (415) 388-9094 or pando@sonic.net.

VALLEJO YC — Every Wednesday night through 9/24. Timothy Dunn, fleetcaptainsail@vyc.org.

Please send your calendar items by the 10th of the month to calendar@latitude38.com. If you're totally old-school, mail them to *Latitude 38* (Attn: Calendar), 15 Locust Avenue, Mill Valley, CA, 94941 or fax them to us at (415) 383-5816. But please, no phone-ins! Calendar listings are for marine-related events that either are free or don't cost much to attend. The Calendar is not meant to support commercial enterprises.

July Weekend Currents

date/day	slack	max	slack	max
7/04Fri	0206	0532/6.0E	0929	1235/4.6F
	1557	1813/2.7E	2118	
7/05Sat	1014	0010/3.2F	0258	0620/5.6E
	2213	1318/4.4F	1639	1900/2.8E
7/06Sun		0103/3.0F	0352	0707/5.0E
	1058	1401/4.0F	1721	1947/2.9E
7/12Sat		0018/3.3E	0439	0751/2.4F
	1048	1300/1.1E	1613	1907/1.8F
7/13Sun		0118/3.5E	0533	0849/2.7F
	2239	1430/1.1E	1710	2002/1.8F
7/19Sat	0207	0529/4.9E	0924	1224/3.7F
	1547	1802/2.4E	2109	
7/20Sun		0001/2.6F	0246	0607/4.8E
	0954	1254/3.7F	1618	1840/2.7E
7/26Sat	0242	0531/2.4F	0856	1105/1.7E
	1352	1714/2.2F	2007	2338/4.2E
7/27Sun	0353	0653/2.7F	1020	1215/1.4E
	1508	1820/2.1F	2109	

South Beach Sailing Center

South Beach Riggers

**Winning
Technology for
the Hot Race or
the Casual Cruise**

- Expert advice, sales and splicing of Vectran, Spectra, Technora, and Dacron by our certified splicer
- Professional survey and tune for your rig
- Standing and running rigging replacement
- Fabrication and hydraulics
- More than 100,000 miles racing and cruising experience



TWO LOCATIONS

399 Harbor Dr. • Clipper Marina • Sausalito • 415.331.3400
Pier 40 • South Beach Harbor • San Francisco • 415.974.6063

The difference between a boat and a yacht



- Mobile Service: *We Deliver!*
- Washing
- Waxing
- Varnishing
- Interior Cleaning



Westwind

Complete Yacht Care

*Serving the entire Bay Area for
more than 20 years*



(415) 661-2205

Pier 40, South Beach on the Embarcadero • San Francisco

Call Toll Free **888-828-6789**



westwinddetailing@sonic.net
www.boatdetailing.com



CAL MARINE ELECTRONICS



Sales - Installation - Service - Integration

- | | |
|--------------|-------------------|
| • Radar | • Instrumentation |
| • VHF | • Chartplotter |
| • GPS | • HF/SSB / e-mail |
| • Antenna | • Electrical |
| • Auto Pilot | • Checkup |

Serving SF Bay with name brand products
and professional quality services since 1952

Done right ... priced right.

415-391-7550

Pier 40 The Embarcadero, SF, 94107
www.calmarineelectronics.com

*Design, Fine Yacht Upholstery,
Fabrication, Etc.*



YACHT: LIN MAR

**NORTH
BEACH
MARINE
CANVAS**

415.543.1887

nbmc@earthlink.net

www.northbeachmarinecanvas.com

Pier 40, The Embarcadero
 South Beach Harbor, San Francisco

Pier 40 • South Beach Harbor • San Francisco

POWER BOAT LISTINGS



42' Bertram Motor Yacht,
1981, \$180,000



Gas and Diesel
Vessels up to 150 feet



39' Sea Ray 390, 1988
\$59,500



37' Bayliner 3788, 1997
\$109,900



37' Sea Ray Sundancer 370,
1990, \$59,900



Bayliner 3218, 1987
\$39,500



32' Grand Banks Sedan,
1980, \$134,000



31' Blackfin Combi, 1997
\$129,000



30' Carver 300 Aft Cabin,
1993, \$69,000



29' Baltic Scand, 1987
\$35,000



28' Bayliner 2855, 2000
\$57,000



27' Farallon Enclosed Helm,
1982, \$89,000



CITY YACHTS • 10 MARINA BLVD.
SAN FRANCISCO, CALIFORNIA 94123

PLEASE VISIT OUR FUEL DOCK AT GASHOUSE COVE MARINA • OPEN 7 DAYS A WEEK • 9AM TO 5PM

YACHTS^{AND}_{THE}CITY

SAILBOAT LISTINGS



Hunter 45, 2006
\$299,000



42' Fountaine Pajot Venezia,
1995, \$264,000



Passport 40, 1985
\$129,500



37' Beneteau Oceanis 370,
1991, \$74,900



36' CS Yachts Traditional,
1985, \$69,900



35' Ericson MkIII, 1987
\$47,500



Sabre 34, 1983
\$54,900



30' Cal 3-30, 1974
\$17,500



30' Hess Bristol Channel,
1997, \$135,000

Call us Toll Free at: (877) 444-5091 • (415) 567-8880
FAX (415) 567-6725



email us at sales@citysf.com • visit our website at <http://yachtworld.com/cityyachts>

❖ 60' SLIPS ❖

NOW AVAILABLE



**PEACEFUL, PROTECTED
FIRST-CLASS YACHT HARBOR**

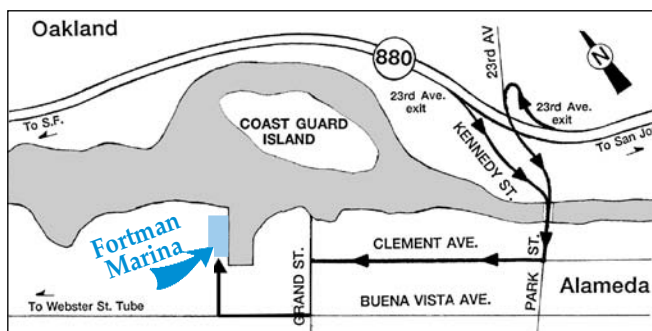

- Sheltered Alameda Location
- Competitive Rates
- Home of the Alameda Yacht Club

1535 Buena Vista Ave., Alameda, California
(510) 522-9080

For directions and rates go to:
www.fortman.com

LETTERS

↑↓ **THERE INDEED CAN BE A 'BLUE WALL OF SILENCE'**

For background purposes, I am a retired Deputy Chief from the Sheriff's Office in Reno. My last assignment at retirement was command of the Detective Bureau. During my career — specifically at the ranks of deputy, sergeant and lieutenant — I investigated and supervised investigations of fatal accidents of all sorts, including boating accidents.

I have followed the details of the Lake County case against Bismarck Dinius through the media, and it is my opinion that this case just cries out for an independent investigation.



COURTESY CHANNEL 7 I-TEAM

Is a 'blue wall of silence' covering up the real cause of this wreck?

Independent in the sense that the Lake County Sheriff's Office and the Lake County District Attorney's Office should never have proceeded to investigate the possible culpability of one of their own. Law enforcement professionals should have recognized immediately the necessity for these local agencies to recuse themselves from the matter.

I can tell you from personal observation that there indeed can be a 'blue wall of silence' formed when agencies investigate one of their own. I am not alleging that this is so in this case, I'm merely saying that there should never have been even the opportunity for such an accusation. There should have been a request made at once to an independent, outside agency to conduct the entire investigation and prosecution.

I urge the California Department of Justice to conduct an inquiry into this tragic accident and the subsequent investigation. Justice for the defendant, Mr. Bismarck Dinius, and for Deputy Perdock, cannot be fairly applied until this is done.

Rod Williams,
Deputy Chief (Ret.)

Rod — The Bismarck Dinius case is back in the news again because on June 11, Judge Richard Martin in Lake Port ruled that there was enough evidence for Dinius to stand trial in the fall for vehicular manslaughter. A pox on the California Department of Justice, headed by former Governor and current Attorney General Jerry Brown, for allowing this outrage to continue.

↑↓ **"EVERY VESSEL SHALL PROCEED AT A SAFE SPEED ADAPTED FOR THE PREVAILING CIRCUMSTANCES"**

How corrupt does the Lake County Sheriff's Department have to be before a citizen's opinion is needed on whether to enforce the law?

Maritime law seldom absolves anyone completely from blame in an accident. Blame is usually assigned in percentages. As I see it, the following Rules of the Road applied in the Lake County case:

Rule 2: "Nothing in these rules shall exonerate any vessel, or the owner, master, or crew from the consequences of any neglect to comply with the rules, or the neglect of any precaution which may be required by the ordinary practice of



THANKS TIM FOR 30 YEARS OF HAULOUTS

For 30 years Tim Grande has been safely lifting and launching boats for Svendsen's Boat Works. For many of our customers he is the face of Svendsen's. Having helped service and haulout many thousands of boats over 3 decades, Tim brings an unparalleled work ethic to our organization. On behalf of our entire Svendsen's team we **Thank You** Tim for your unwavering dedication, loyalty and professionalism. It's safe to say, "Tim, You're the Top Gun of Travelift Pros."



Free Svendsen's Haulout Contest

To celebrate Tim's 30-year anniversary, enter our "Free Svendsen's Haulout Contest." Simply estimate the total number of boat linear feet Tim has hauled in his 30-year Svendsen's career. Email your guess to contest@svendsens.com. If your guess is closest, we'll haul your boat for free. (**Hint:** it's between 900,000 and 1,000,000 linear feet)

Deadline for entry is July 31. Please, one guess per person. Haulout subject to qualifications.



SAIL HOME TO PARADISE



No channel to access one of the most desirable parts of the Bay with amazing anchorages in the sheltered beachfront coves of Tiburon's Gold Coast.

- ★ Deep water berthing for boats up to 110'.
- ★ On Tiburon's Gold Coast.
- ★ Two miles to Paradise Park and five miles to Angel Island.
- ★ Six miles to Sam's and downtown Tiburon.
- ★ New beautiful Tiburon Yacht Club with Friday Night Racing.
- ★ Flat water and warm breeze.
- ★ Tiburon's gourmet market and shopping nearby.
- ★ Affordable guest berthing for boats up to 110'.
- ★ 12 miles to San Francisco.
- ★ Marin's great restaurants and shopping within five miles.



The Paradise Cay Yacht Harbor is now accepting berthing applications for boats of all sizes. Give us a call at (415) 435-4292

Paradise Cay Yacht Harbor

Trinidad Drive • Tiburon

415.435.4292

LETTERS

seamen, or by the special circumstances of the case." Deputy Perdock, as owner and master of the powerboat that hit the sailboat at high speed, did not take the precaution to proceed at a safe speed in limited visibility caused by the darkness and background lights.

Rule 5: "Every vessel shall at all times maintain a proper lookout by sight and hearing as well as by all means appropriate in the prevailing circumstances and conditions as to make a full appraisal of the situation and of the risk of collision." Given the fact that Perdock hit the near-stationary sailboat only a split second after he saw it is proof in itself that nobody on his boat was standing a proper lookout.

Rule 7: "Every vessel shall use all available means appropriate to the circumstances and conditions to determine if a risk of collision exists. If there is any doubt, such risk shall be deemed to exist." Not being able to see because of the darkness and background lights, and knowing that it was not uncommon for people and floating objects to be on the lake without lights, Deputy Perdock was required to assume there was a risk of collision and use all available means — proceeding at a slow speed — to avoid such a collision.

Rule 18a: "A power-driven vessel shall keep out of the way of: i) a vessel not under command; ii) a vessel restricted in her ability to maneuver; iv) a sailing vessel." Perdock slammed into a boat that was both a sailboat and, because of the zephyrs, was restricted in her ability to maneuver. Had he kept out of the way of the sailboat by travelling at a safe speed, the accident never would have happened.

Rule 19: "Conduct of vessels in restricted visibility. (b) Every vessel shall proceed at a safe speed adapted to the prevailing circumstances and conditions of restricted visibility." Forty to 45 mph on a pitch-black lake while headed toward background lights is not proceeding at a safe speed given the restricted visibility.

Whether the sailboat's lights were on or hidden by the background lighting may be of importance to Mark Weber, the owner of the sailboat, or the family of Lynn Thornton, but they should be all but irrelevant to the criminal case. One could argue that the sailboat operator was under the influence, and that the lights of the sailboat were off — both have penalties under law — but it's obvious that neither was the predominant cause of the collision. The sailboat did not speed in front of nor broadside to Perdock's high-speed powerboat, but rather the powerboat rammed the sailboat on the stern quarter. Even if the sailboat's lights weren't on — which is disputed — the powerboat shouldn't have been travelling at such a high speed that the operator couldn't see her 40-ft mast with the sails up.

Either Perdock saw the sailboat or he did not. If he did not see it, he was in clear violation of Rule 5, Rule 7, Rule 18a, and Rule 19. If he did see the sailboat, he was in violation of Rule 2 as a negligent seaman, Rule 16, and Rule 18a.

An average mariner such as myself would have been held accountable for the death of Lynn Thornton under such circumstances. For a member of the law enforcement community to try and dodge his responsibilities indicates a much higher crime than bad seamanship or poor judgement. If Deputy Perdock had immediately apologized and taken responsibility for his unsafe and deadly actions, it would have been easier to put some of the blame on the group out sailing and drinking in limited visibility. But for the Sheriff's Department to hold their own blameless, and prosecute a sailor who couldn't have done anything to prevent the crash, is a travesty of justice. Even if *Beats Workin' II* had been a "vessel not under command," Perdock would still have been bound by Rule 18a(i)



STRATIS: DEFINING THE FUTURE

STRATIS. The latest in advanced sail technology.

Lighter. Unique pre-preg fiber and film lamination process precisely controls the amount of adhesive in each **STRATIS** sail.

More Durable. Precision lamination means strength and effective shape-holding across the wind range, which adds up to durability.

Join the revolution! Contact your local Doyle loft.

Doyle San Francisco

Bill Colombo & Rusty Canada
2035 Clement Avenue
Alameda, CA 94501
510-523-9411
sanfrancisco@doylesails.com

doylesails.com

BETTER ENGINEERED SAILS

800-94-DOYLE

Serious Sailors

isotherm
Marine Refrigeration

isotemp
Marine Stainless Steel Water Heaters



The Winning Team: Isotherm, Isotemp and You!

- ▶ 45 Years of Marine Heritage
- ▶ Refrigerators and freezers up to 9 cubic feet
- ▶ Build-in units up to 17 cubic feet
- ▶ Water heaters up to 20 gallons
- ▶ Complete range of marine products

Blue water sailors know how important dependable refrigeration and hot water are to a successful cruise. Built of the highest quality materials, Isotherm and Isotemp products are designed to last and use the absolute minimum of battery power.

Refrigeration systems including holding plate systems, water cooled, air cooled, SP thru-hull, and ASU energy management systems. Top loading refrigerators, cabinet refrigerators, drawer refrigerators stainless steel doors, glass front doors. Stainless steel water heaters

indel
Webasto
Marine USA

1-800-422-9711

www.IndelWebastoMarineUSA.com

Isotherm and Isotemp are distributed on the West Coast by:

Fisheries Marine Supply - Seattle 800-426-6930
Aegis/MMI - Newport Beach 800-747-3014

Service, Installation and Sales:

Miller and Miller Boatyard - Seattle 206-285-5958
Svendsen's Chandlery - Alameda 510-521-8454
Southern Cal Marine - San Diego 888-657-1606

LETTERS

to avoid it. Perdock was clearly going too fast for the conditions, period. The only thing that made the collision deadly was Deputy Perdock's negligent and irresponsibly high speed, which was in violation of many of the rules of the road.

Mark Wieber
Lafayette

Mark — It's true that blame is assigned on a percentage basis in many maritime accidents. As we've previously written, if it's true — and there is strong evidence to the contrary — that the sailboat's running lights were not on, we would have assigned the blame as follows: 79% to Deputy Perdock for violating Rules 2, 5, 7, 18a, and above all, 19, which requires

COURTESY CHANNEL 7 TEAM



We don't know Bismarck Dinius, but in our mind, there is no doubt he's being thrown under the bus by the D.A. to protect Deputy Perdock.

a boat operator to proceed at a safe speed in conditions of restricted visibility. 20% to Mark Weber, the owner of the sailboat, who was standing in the companionway. Under California boating law, Weber was in command of the vessel, therefore it was his responsibility to make sure the lights were on. He was also under the influence of alcohol. For whatever reason, he's not been charged at all. 1% to Bismarck Dinius, for being under the influence — although not by much — while at the helm.

If the defense witnesses and experts are correct that the sailboat's running lights had indeed been on, we would assign 100% of the blame to Deputy Perdock. After all, given the conditions, even the world's best and most sober helmsman couldn't have done anything to avoid the speeding deputy's oncoming powerboat. But for Bismarck Dinius — a guy we don't know and have never met — to be made the scapegoat, and for the other two to be charged with nothing, is preposterous.

↑↓ I KNOW WHAT I'M TALKING ABOUT

I'm a professional captain and in the marine management business. So I know what I'm talking about when I say in no uncertain terms that what Deputy Sheriff Perdock did — operate his powerboat at high speed in total darkness — was negligent. He, rather than a guy sitting next to the helm on a drifting sailboat, is the one who should be held responsible.

Stan Gibbs
Planet Earth

↑↓ READERS SHOULD WRITE THE FOLLOWING LETTER

I've been following the Lake County prosecution of Bismarck Dinius closely, and I thought it worthwhile that I relay a conversation I had with an analyst at the Public Investigations Unit of the California Attorney General's office. The analyst mentioned that the Attorney General's office was following the case to determine if there has been some impropriety in the actions of the Lake County District Attorney, and that the general public should send their opinions to piu@doj.ca.gov. The person I spoke with was very clear that no one would reply to anything sent to that address, and that the letters would primarily be used for statistical analysis purposes to determine the scope of the level of public interest — outrage? — in the case.

If any *Latitude* readers care about the case, please consider

XOJET[®]
Presents

October 4-5, 2008
San Francisco Yacht Club
Belvedere, CA

Raise a sail and
help fight leukemia,
lymphoma and
myeloma.

THE
LEUKEMIA
CUP
REGATTA



*The Leukemia &
Lymphoma Society*



VIP Dinner
Special Guest



Rupert Murdoch

PHOTO: DAVID DIBBLE

- Event Dates:** Saturday, October 4, VIP Dinner, and Sunday, October 5, Leukemia Cup Regatta
Regatta Format: PHRF with spinnaker & non-spinnaker divisions, and one design class with six or more boats
VIP Dinner: Saturday evening with special guest RUPERT MURDOCH, Chairman & CEO of News Corporation
Sign up today: By registering online at www.leukemicup.org/sf
Questions: For event details contact Leslie Crouch at 415.625.1133 or Leslie.Crouch@lls.org
For race details contact SFYC Race Office at 415.789.5647 or race@sfyc.org

Sailing
WORLD

West Marine
We make boating more fun!

Genentech
BIO@NCOLOGY™

SPONSORS

REX&CO

blue of california
Blue Shield of California
An Independent Member of the Blue Shield Association

ClubNautique
www.clubnautique.net

Ken Gardiner
MODEL MAKER



PASSPORT CAPITAL



MOUNT GAY RUM
BARBADOS

WENTE
VINEYARDS

Johnnie Walker
LIMITED EDITIONS



CORSAIR



MARINE

INTERNATIONAL



CORSAIR'S NEW 750 SPRINT

Some say, "Faster than a speeding bullet." Longer cockpit, larger sail area, taller mast, deeper daggerboard, bigger rudder, bigger bow pole. MORE FUN! Great family cruiser. Sailing should be something that feels good. You got-a-Tri this one! Call Gary for a ride (510) 865-2511.

When the first Corsair Trimaran blasted by every sailboat on the water in 1985, a precedent was set for a sailboat to offer the best in high performance racing and cruising on the average family budget. It must be easy – easy to sail, easy to trailer, easy to launch, easy to afford, easy to maintain, and easy on the eyes. Since the launch and take-off of the first Corsair Trimaran, Corsair Marine has exceeded every requirement of this precedent by developing new and better material combinations and construction techniques for increased performance through lighter weight, and relentlessly improving design elements for increased durability and safety, and improved aesthetics.



CORSAIR 31

Ask about the full line of Corsair multihulls:
Sprint 750, 24, 28, 31, 37, 50

CORSAIR 50
Fast Cruising Catamaran
New for 2008

In Northern California



314 Tideway Dr., Alameda, CA 94501
www.helmsyacht.com
(510) 865-2511

New Southern California Dealer!

West Coast Multihulls
1053 Rosecrans, San Diego, CA 92106
www.westcoastmultihulls.com
kurt@westcoastmultihulls.com
(619) 571-3513

LETTERS

sending an email, perhaps as follows:

Dear PIU:

I am concerned that the Lake County DA has acted improperly in pursuing charges against Bismarck Dinius. Mr. Dinius was operating a sailboat at 5 mph with cabin and navigational lights on when a powerboat piloted at 40+ mph by Russell Perdock hit the sailboat and tragically killed Lynn Thornton of Willows. Marine safety experts have testified to the state of the nav lights and the speed of Mr. Perdock's boat.

Mr. Dinius may have been intoxicated at the time of the accident, but marine safety experts have testified he would not have been able to avoid the powerboat even if he was sober. Mr. Perdock may have been intoxicated at the time of the accident, but an investigating officer was told not to apply a breathalyzer test to Mr. Perdock at the docks after the incident.

I believe that the Lake County DA made the decision to prosecute Mr. Dinius solely due to Mr. Perdock's employment with the Lake County Sheriff's office. The Lake County DA has overlooked key evidence, ignored statements by eyewitnesses, and pursued a prosecution that goes against common sense and maritime right-of-way rules.

The criminal prosecution against Mr. Dinius has important ramifications for civil suits that have since been raised. If Mr. Dinius takes a reduced-sentence plea offered by the DA, civil claims against Mr. Perdock may be seriously limited. By prosecuting Mr. Dinius, despite clear wrongdoing by the other party, the Lake County DA has taken a clear initiative to protect Mr. Perdock despite his role in the death of Ms. Thornton.

Furthermore, I believe the Lake County Sheriff's office may have been involved with evidence tampering — the sailboat's navigational light switches were noted as being switched 'on' at the scene, yet were switched 'off' during the inspection at the police impound yard two days later. It's also interesting to note that an investigating officer was instructed not to give Mr. Perdock a breathalyzer test on the docks after the incident, as that officer recently confessed to television reporter Dan Noyes.

These facts lead me to believe that a 'good ole boys club' is operating in Lake County, and I strongly encourage the California Attorney General to act in this matter. I recommend that the Attorney General start an independent investigation into this impropriety, and evaluate illegal actions at both the Lake County DA and Sheriff's offices.

Regards,
Your name
Your city, your state
Your phone number

Will Sitch
San Francisco

Will — It's not true that the sailboat was moving at 5 mph. There were only zephyrs on the lake, and she was described as drifting, and thus would have been unable to make any swift change of course. The sailboat — and Lynn Thornton — were sitting ducks.

↑↓ I'D LIKE TO CONTRIBUTE TO A DEFENSE FUND

There must be a defense fund for Bismarck Dinius. Do you know where we can contribute? I'd donate to that fund.

In addition, as with the O.J. case, can't the estate of Ms. Thornton file a wrongful death civil claim against Perdock?

Russ Irwin
Maine

In Northern California



314 Tideway Dr., Alameda, CA 94501
www.helmsyacht.com
(510) 865-2511

**In Southern California
West Coast Multihulls**

1053 Rosecrans, San Diego, CA 92106
www.westcoastmultihulls.com
kurt@westcoastmultihulls.com
(619) 571-3513

SEAWIND



SEAWIND 1000XL

**Come see the Seawind 1000XL and 1160
both at the San Diego Summer Boat Show
July 24-27**

HELMS YACHT SALES

WEST COAST MULTIHULLS



SEAWIND 1160, 2006

Loaded and ready to go cruising! Like new and impeccably maintained Boat of the Year blue-water cruiser from Australia's premier builder. In Mexico. Email kurt@seawindcats.com or call (619) 571-3513. \$469,000



CORSAIR 36, 2003. Cruise Mexico in the winter and Tahoe in the summer. Comes with a trailer. Often sailed at 20 knots, yet comfortably fitted out with 3 double and 1 single berths, full galley, 2 showers and all the amenities. \$198,000. Call Gary (510) 865-2511.



SHUTTLEWORTH 47

New listing.
Call Gary Helms at
(510) 865-2511.



28' CORSAIR 28R, 1997

Racing, carbon speedster.
\$71,000!



NEW!

**WEST COAST
MULTIHULLS
NEW DEALERS
FOR PDQ
POWER
CRUISING
CATAMARANS**



36' CATALINA, 1993

Exceptionally clean, ready to cruise,
tall rig. In Southern California. \$69,000.
Call Kurt (619) 571-3513.



32' PDQ CRUISING CATAMARAN, 1996

Lots of Canadian quality built into this proven design. All the right stuff and **READY FOR MEXICO!**
Asking \$118,000. Call Kurt (619) 571-3513.

SWISS TECH SAILING PRODUCTS: SIMPLY THE BEST

Please see our new Flash animated product descriptions
at: www.swisstech-america.com

Mast Lift



- 10-to-1 winch hoist for safe and easy mast climbing and lifting
- 45' and 85'

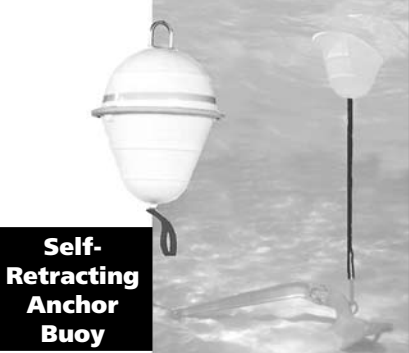

Self-Retracting Anchor Buoy

All products thoroughly tested in the toughest conditions.

Strong manufacturer's guarantee.

MOORING GEAR

- Many products for many applications: grabbing moorings/bullards, tying up to posts, locking, etc.

Mooring Buoy Catch Hook



Mooring Safety Lock



Ask about our discounts for Baja Ha-Ha participants. Proceeds from your purchase will go to Make-A-Wish Foundation.



See detailed descriptions of all our cruising products at:

www.swisstech-america.com
(408) 505-SAIL (7245)

LETTERS

Russ — You can contribute to defense fund for Bismarck Dinius by sending checks made out to Bismarck Dinius, with "Bismarck Dinius Defense Fund" in the memo section, to Sierra Central Credit Union, Attn: Brian Foxworthy, Branch Manager, 306 N. Sunrise Ave., Roseville, CA 95661. The estate of Ms. Thornton, and others, have filed suit against Deputy Perdock. We'll bet a nickel there is no way he's going to have enough insurance to cover all judgements that will go against him.

↑↓ HOW THE LEGAL PROCESS WORKS

I agree with *Latitude* about who was and was not at fault in the boating accident on Clear Lake that claimed the life of Lynn Thornton, and who should and should not be charged as a result of that accident. However, your castigation of Judge Richard Martin leads me to believe that you have a basic misunderstanding of how the legal process works in this instance.

If 1) Bismarck Dinius was at the helm, 2) he was over the blood alcohol limit, and 3) the boat's running lights were not on, Dinius is, by law, liable for manslaughter. When determining whether there is enough evidence to proceed to trial, the judge's job is to determine whether each of those three elements have legally admissible evidence that supports them. If so, his decision was correct. In making this determination, all legally admissible evidence is to be taken as true, and evidence to the contrary is to be ignored. Which legally admissible evidence one believes is a matter of fact for trial, and is not considered when determining whether to proceed.

As I've said in previous emails, the big problem here is bad law that allows travesties like this to take place. If the operator of a powerboat that was in violation of any of the rules of the road, and that collided with a manual- or sail-powered vessel, were automatically liable for the accident, Russell Perdock would have been charged and Bismarck Dinius almost certainly would not have been. Dinius is just serving as a patsy to take the focus off Perdock, who is the real cause of the accident. A campaign by sailors to change the law would go a long way toward preventing this type of travesty of justice from happening again.

Jeff Hoffman
San Francisco

Jeff — Are you saying that it's up to us, the general public, who are by and large the victims rather than beneficiaries of the U.S. legal system, and are certainly impotent against the mighty legal industry lobby, to change the laws to make them more just? Great. What next? Suggest that American motorists take the bull by the horns and get Arab countries to pump more crude at lower prices?

We understand enough about law to realize that Judge Richard Martin probably had his hands tied in making the decision he did. But as nearly powerless victims of the legal system, and seeing what we believe to be massive injustice in Lake County, we feel we have no alternative but to confront the problem in sometimes asymmetrical ways. As such, we're going to use every opportunity to raise hell and let more people know about the travesty that's occurring.

While Bismarck Dinius is certainly a major victim in this case, an even bigger loser is law enforcement and the legal system. Like a lot of folks, we previously believed that, with a few exceptions, cops and district attorneys were at least reasonably honest people who cared about justice. No more, not after the nonsense in Lake County, which even more tragically has been blessed by the silence of the Attorney General's Office

The only Haul Out that smiles back!

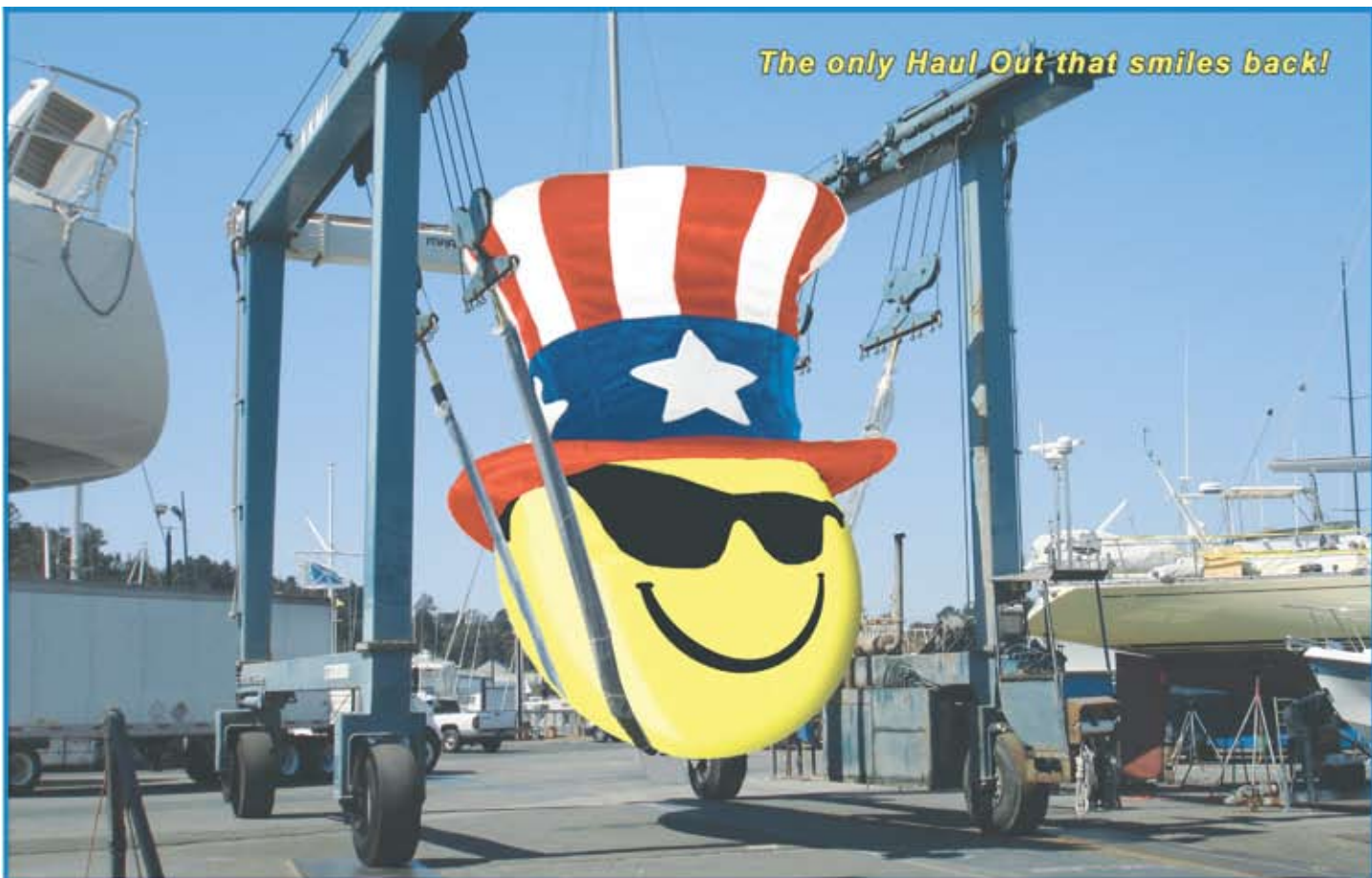

Full Service Boatyard ♦ Mechanical ♦ Rigging ♦ Electronics ♦ Chandlery

Home of the Free...Haul Out

*Bring your boat to KKMI this July and get a **FREE HAUL OUT** with your bottom painting package.*

*Our goal is for you to be a happy boat owner, on the water and in the yard, which is why every KKMI bottom job comes with a **Satisfaction Guarantee!*** We're also now offering **Saturday Haul Outs** to make the process of maintaining your boat that much easier!*

*Not only do you get the best value on the Bay, you'll get your boat back **on time and on budget!***

*Ask us about our **Free Shuttle Service**. You've got nothing to lose except the hassle!*

**See kkmi.com for details*



Keefe Kaplan Maritime, Inc. • www.KKMI.com
Ph (510) 235-KKMI (5564) • yard@kkmi.com
530 W. Cutting Blvd • Pt. Richmond, CA 94804

Seawear™

Nautical and Celtic Jewelry



Summer 2008

info@seawear.com

www.seawear.com

LETTERS

in Sacramento. The next time we're called to jury duty, we're going to be hard pressed to believe the law enforcement officers and the district attorney have any credibility whatsoever.

↑↓ MY DIESEL HAS BEEN IDLING SINCE '67

I found Jamie Gilardi's letter about the damaging effects that idling has on diesels — and *Latitude's* reply — to be quite interesting.

I'm the owner of *Inspiration*, a 50-ft steel Garden ketch that has been well-used since she was built in '67. I had her



LATITUDE / LADONNA

To idle or not to idle, that is the question. At least it was before diesel prices soared.

in Mexico for 20 years, but now keep her at Channel Islands Harbor near Oxnard. *Inspiration* is equipped with a six-cylinder, seven-liter Volvo MD-70 engine rated at 165 horsepower. Based on fuel consumption at one-half pound per horsepower hour, the engine develops just 25 horsepower at hull speed, with the fuel consumption being just 1.7 gallons per hour at 1,350 rpm.

Full power — resulting uselessly in stirring water — is 2,500 rpm.

In other words, my Volvo has basically idled for 40 years, during which time it's only required minor maintenance. The only thing that's been done in all that time is to remove the head — yes, there are two cylinder heads on this inline, six-cylinder engine (to have all six cylinders covered by one large cylinder head would mean a very heavy cylinder head, so Volvo used two cylinder heads, each one serving three cylinders) — to correct head gasket leaks. This engine has some dozen small cylinder head gaskets, one for each oil and one for each water passage, in addition to the cylinders themselves. That was done twice, more than 10 years apart.

My idling Volvo has been as reliable as a rock, so I wonder how bad idling actually is for an engine.

Bill Steagall

Inspiration, 50-ft Garden ketch
Channel Islands Harbor, Oxnard

↑↓ IT'S OK TO IDLE BUT DON'T RUN THEM COOL

I just returned from Arizona, where I located and visited the gravel pit where I operated my first diesel bulldozer. I worked there 66 years ago, meaning 1942, while helping build Kingman Air Force Base. Since '54, my family construction companies have owned hundreds of diesels in our equipment, and as a hobby, I still operate diesel-powered machines a couple of days a week.

In all these years, I don't recall ever paying to repair a diesel that was damaged from idling. Keep in mind that air compressors and diesel generators are required to idle for as many hours as necessary until they sense a demand, at which point they instantly power up to full throttle until the load is reduced, and then return to idle. Many of our other diesel-powered equipment was also required to work at low speeds a majority of the time. So based on that considerable experience, I have never hesitated to operate my sailboat diesels at low speeds or for charging batteries or running the

DESTINATION MARINA BAY

Still Exploring the Bay?

*Come discover Marina Bay
in Richmond this summer.*

*Book your Summer Club Cruise
Reservations NOW!*

LONG TERM TENANTS ENJOY:

- Deep draft harbor (race boat friendly)
- Berth to Bay in 15 minutes
- Nearby village of Point Richmond
- Onsite deli & restaurant



**MARINA
BAY
YACHT
HARBOR**

A Certified Clean Marina



www.MarinaBayYachtHarbor.com

1340 Marina Way South, Richmond, CA 94804

(510) 236-1013



SPECTRA
WATERMAKERS™

- Super efficient
- High reliability
- Worldwide sales and support



We have a watermaker to fit any need,
from 150 to 1000 gallons a day.

WEST COAST DEALERS

Emerald Harbor Marine, Inc.
Seattle, WA 98199
Tel: 206-285-3632
www.emeraldharbormarine.com

Svendsen's Boat Works
Alameda, CA 94501
Tel: 510-521-8454
www.svendsens.com

Channel Coast Marine
Oxnard, CA 93030
Tel: 805-985-0220
www.channelcoastmarine.com

Outbound Yacht Services, Inc.
Dana Point, CA 92629
Tel: 949-488-0652
www.outboundyachtservices.com

Daily Marine
San Diego, CA 92106
Tel: 619-222-9613
dailymar@aol.com



Your Dream, Realized.

Spectra Watermakers • Tel: 415-526-2780
www.spectrawatermakers.com

LETTERS

freezers. In 45 years of owning diesel-powered sailboats, I've never had to replace a fouled injector or had other problems caused by carbon buildup. Mind you, I do most of my motoring between 1,000 and 1,200 rpms, for maximum fuel efficiency, using the biggest prop that will allow my diesel to reach its maximum-rated rpm.

It's also worth considering the experience of diesels on the Alaskan Pipeline or in the Northern Plain states. The block heaters and glow-plugs do not put out enough heat to counter the sub-zero temperatures in the winter that allow the motors to start. So it's common to let equipment idle 24 hours a day, if necessary, to have it available for use during the coldest weather. As a result, a piece of equipment sold when the pipeline was completed may have had 10,000 hours on the engine, but only a third of that on the transmission and tracks. I do not recall hearing that that equipment had any more problems than engines that were worked normally for that number of hours.

On the other hand, I'm absolutely convinced that running diesel engine at cool temperatures does damage, and must be avoided to the best of our abilities. The best temperature for running a diesel is between 180° and 200°, but using saltwater heat exchangers means we have to limit the temperature to 170°, as salt precipitates out of sea water much faster at higher temperatures. So 170° thermostats are very important, and should be used at all times.

I'm not sure my years of experience alone makes me an expert, but paying for repairs sure makes a person pay attention to the causes of damage to engines.

Ernie Copp
Orient Star, Cheoy Lee Offshore 50
Long Beach

↑↓ NEVER ASSUME SHIPS STAY IN THE CHANNEL

I was recently sailing in the San Francisco ship channel, the one outside the Gate, in varying spells of rain or thick fog. Because of the lack of visibility, we were monitoring the Vessel Traffic Service (VTS) and heard that a tug was pulling a barge one mile east of Buoy 8. Since we had about one-mile visibility, we looked around and there was the tug, astern of us. As we tried to sail further west, the tug overtook our position by a course that was just north of the San Francisco channel buoys, and therefore not in the channel.

I'd been told that, in conditions of reduced visibility, the best place to be is just outside the shipping channel. I have since asked around and have been told that tugs sometimes travel outside the channel if they are pulling a hard-to-handle barge or are heading for a dump site. In quarter-mile visibility, it would be a great surprise to come across a tug outside the channel.

What is the official ruling on occurrences such as this, and how often does it occur? Any thoughts or wisdom will be greatly appreciated.

Bob Wills
Santa Rosa

Bob — We're under the impression that ships/tugs/commercial vessels can go wherever they want unless strictly prohibited by law — or if the water is too shallow. As such, it wouldn't shock us at all to find a tug/ship/commercial vessel outside of the San Francisco ship channel. We're not sure how often it happens, but that it happens at all is reason to always be on guard against it.

It may also surprise you that inbound ships often get permission from Vessel Traffic Service to use the outbound lane

*Come Visit the Crown Jewel of the Delta...
Overnight Visitors and Yacht Club Cruises Welcome!*

*Visit us this
Weekend!*

PHOTO CHRISTINE WEAVER

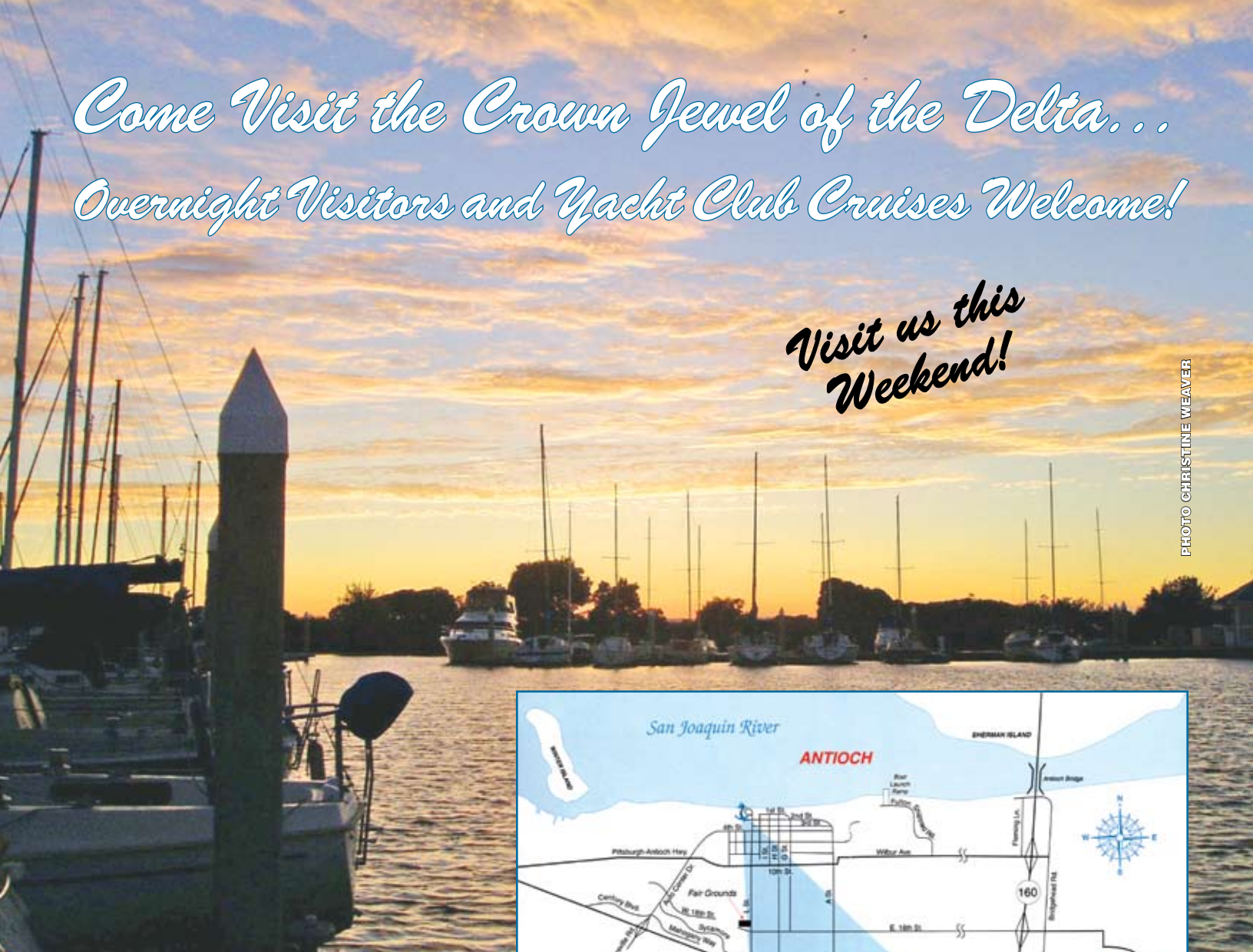

- FREE wireless Internet
- Open berths from 24' to 72'
- Covered berths from 32' to 50'
- 10' average water depth
- Easy access by boat, car or train
- Humphrey's on the Delta Restaurant

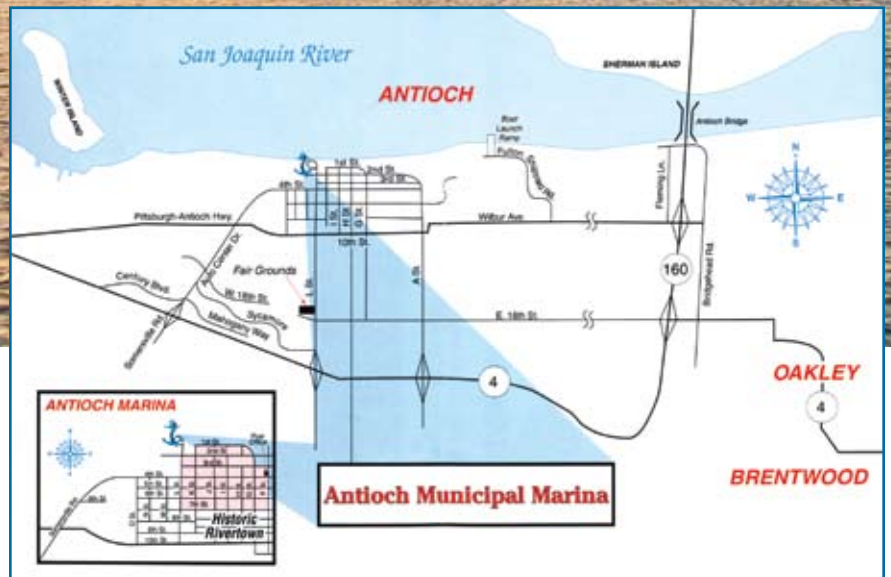

*Antioch
Municipal
Marina*

#5 Marina Plaza, Antioch
(925) 779-6957
marina@ci.antioch.ca.us
www.ci.antioch.ca.us



Introducing...

NORTH SAILS

direct



...a new experience in sail buying
for racing and cruising sailors!

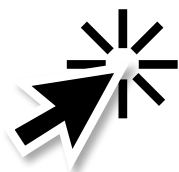

Visit our new website today to
learn how you can save on new
North cruising or racing sails*
...or call toll free at 888-424-7328.

northsailsdirect.net

formerly Cruising Direct

*boat size restrictions apply

LETTERS

inside the Bay, and vice versa. So we wouldn't make many assumptions about 'lanes'.

Our attitude is that you always have to be alert to the approach of ships no matter where you are, and that if you're on a small boat, there should never be an excuse for getting hit by a ship — even if the captain goes insane and tries to run you down. That's why we keep a close watch, rely on radar to know what's around us during times of poor visibility, and give ships plenty of room. Furthermore, before long we're going to invest in an Automatic Identification System (AIS) unit, which is a much less expensive yet more informative way to be alerted to the approach and intentions of ships.

↑↓ SAILBOATS 'ALMOST ALWAYS' HAVE RIGHT OF WAY

Regarding the letter in a recent issue commenting on vessel traffic situations in the Estuary, the author of the letter mentioned that sailboats that overtook him complained that he was in their way. While the author may have been motoring his boat, in light of Rule 13 of the Rules of the Road, perhaps you'd like to reconsider your reply that sailboats have the right-of-way over motor vessels.

Mike Farrell
Lassie, Pearson 28
Pt. Richmond

Mike — What we should have written is that sailboats "almost always" have the right-of-way over boats under power. The exceptions — when in restricted waters in which the vessel under power can't maneuver; when the boat under power is at anchor or not under command; and in Rule 13 cases, when overtaking a powerboat. We sort of assumed that people realized that boats under sail don't have the right to ram into anchored boats or the transoms of powerboats that are moving slower than they are, but we should have been clearer about it. Thanks for bringing it up. Sailboats also have to stay clear of powerboats if the powerboat is in a specific traffic lane — although there are no such lanes in the Oakland Estuary.

↑↓ AN ATTITUDE OF GRATITUDE FOR LATITUDE

Four years ago, I was at the end of a very long chapter in my life. I was in the midst of a divorce and it seemed likely that I would lose my business and my home. The ugly process of two lives being torn limb from limb was in full swing.

As I began to come out of my divorce, one of the nicer experiences was beginning to date again. The first woman I dated asked me if I was interested in sailing. I had sailed all over Southern California aboard my dad's Ericson 27 as a kid. When I was 14 years old, I'd read Robin Lee Graham's book *Dove*, and dreamed of sailing around the world as he had done. On our next get together, the woman brought me the April '04 issue of *Latitude 38*. I still have it. Since then, *Latitude* has been my primary connection to the vibrant sailing community that radiates outward from San Francisco Bay. Like many other readers, I wait anxiously each month for my subscription to arrive. The day it gets here usually finds me up late, unable to put the magazine down until I have completed my first pass.

Since reading that first issue of *Latitude*, my interest in sailing — and specifically long-range cruising — has continued to grow. As my passion for sailing grew, it was time to do something about it, so I chartered a boat for three weeks in the British Virgins. I thought this would be a good test run for the cruising lifestyle. Everything went wrong with that three-week charter, which was on a crappy boat from a budget charter outfit. But I took it as a good sign that I couldn't wait



MARINA RIVIERA NAYARIT

AT LA CRUZ



Ask for our
Summer Package

Up to 400 Vessel Capacity (30-400 ft.) • Fuel Station • Dry Dock • 150-ton Travel Lift • Yacht Club
Coming Soon: Hotel Site • Condominiums • Restaurants & Bars • First-Class Services and Much More!



Marina Coordinates: Lat. 20°45'N, Long. 105°24'W
La Cruz de Huanacastle, Bahía de Banderas, Nayarit, México

Tel (011 52) 329 295 5526 • info@marinarivieranayarit.com • www.marinarivieranayarit.com





**SVENDSEN'S
MARINE**

 **SolidNav.com**
The first alternative for everyone



**Replace Your Atomic 4
Now with SolidNav Electric
Propulsion System**

Only \$4,995.95

Call for installation estimate today!

**ALL BATTERIES
25% OFF**



**40% OFF Batteries
with purchase of a
SolidNav system.**

PRICES VALID THROUGH JULY 31, 2008

**LOCATED IN THE ALAMEDA MARINA
1851 Clement Avenue, Alameda**

CHANDLERY: 510.521.8454 • BOAT YARD: 510.522.2886

LETTERS

to get back on the water after that diesel-soaked, cockroach-infested, anchor-dragging fiasco of a charter.

So I joined SailTime in San Francisco, which I found to be a great way to pretend like you own a boat without the huge time and financial commitments of actually owning one. For 18 months, I learned and enjoyed the challenges of sailing on the Bay, all the while using *Latitude* as my guide to sailing resources. As I began to think about owning my own boat, I decided to try another charter in the British Virgins, but this time on a brand new Beneteau 47.3 with all the trimmings. One of the first things I realized was how much my skills and confidence had increased in such a short time.

But prior to the charter, something strange and evil began to happen. While at the Strictly Sail Boat Show in Oakland, I took a test sail on a SeaWind 1160 catamaran. Prior to that, I had never sailed on a cat and had the usual negative bias about the supposedly jerky motion and the risk of capsizing. But as the list of features for my own cruising boat came into focus, I couldn't deny that catamarans seemed to have a lot to offer. It was too late to change my charter booking from a monohull to a catamaran, so off I went to the BVIs and the shiny new Beneteau. I loved that boat. She was fun to sail, comfortable — and I knew there were several available in California in my price range. The only problem was that, while in the British Virgins, I couldn't take my eye off the catamarans.

After returning to the Bay Area, I began to ratchet up my boat shopping. I set a one-year deadline for buying a boat, so I began to kick monohull tires around the Bay. Meanwhile, I executed a plan to sell half of my business — which I didn't lose after all — which allowed me extended periods of time for cruising. As part of my boat search, I decided to take a test sail on a unique cat with Gary Helms. I'd asked Gary about the availability of catamarans in the area, and he said there was only one Seawind 1000 available. So I asked him about the F-41 that I saw listed on his website. "Oh," he said, "that cat . . . that boat is kinda special. She was custom made and requires a special kind of person to appreciate her." Gary is definitely on the low pressure side of the sales world, but after a little arm-twisting, he agreed to let me see the catamaran.

And not long after, we sailed the Ian Farrier-designed 41-footer in typical Bay conditions. As we beat up through the Slot, we passed Alcatraz going 12 knots with one reef in the main and our beverages sitting undisturbed on the cockpit table. All that room and stability — and she was fun to sail, too. Well, I was quickly hooked. The next six weeks were a blur of offers, bankers, insurance brokers, surveyors, emails to various sailors and cat owners as well as Ian Farrier, and appropriate big decision stress. But in August, I became the proud new owner of the F-41 sailing catamaran *Endless Summer!*

When I stepped aboard *Endless Summer* for the first time, I was immediately impressed by the function over form approach to the cockpit layout. There is no wood, no fancy trim, no fluff. The only thing shiny in the entire aft half of the boat are the five large chrome winches. One is set horizontally in the center of the aft section of the cockpit area, serving as a line clutch with about 10 lines led aft from the rotating mast. There are two stainless steering wheels, one on each side of the cockpit, each with a full complement of engine controls and electronics. The entire boat is cored fiberglass, and finished inside and out to a high gloss. *Endless Summer* sports a retractable 11-ft carbon fiber bowsprit, a carbon fiber cross beam, carbon fiber chain plates, and only weighs 13,000 lbs. when fully loaded. The cabin top has an aft-facing opening



ULLMAN SAILS

The Sailmaker to Champions!

ULLMAN SAILS Super Spinnaker Sale



Glide through summer with a new cruising spinnaker, and enhance your sailing pleasure.

Order a new Ullman All-Radial Cruising Spinnaker and receive a **Free ATN Spinnaker Sock!**

Place your order between July 1 and July 31, 2008.

For further information and color panel diagrams for your boat, contact your local loft or dealer listed below.



CONTACT AN ULLMAN LOFT OR REP FOR SERVICE AND SALES

LOFTS:

Newport Beach
(714) 432-1860
2710 S. Croddy Way
Santa Ana, CA 92704
Dave Ullman
Bruce Cooper
Steve Beck
Erik Shampain
One Design
Charlie Ogletree

San Diego
(619) 226-1133
2805 Canon
San Diego, CA 92106
Jim Clinton
Tom Niebergall
Chuck Skewes
Ty Hokanson

Long Beach
(562) 598-9441
6400 Marina Drive #9
Long Beach, CA
90803
Bryan Dair
Steve Beck
(562) 243-9710

Marina del Rey /
King Harbor
Mike George
(310) 645-0196
Steve Beck
(562) 243-9710

Ventura
(805) 644-9579
3639 E. Harbor Blvd.
#111
Ventura, CA 93001
Gary Swenson
Deke Klatt

Santa Barbara
Ken Kieding
(805) 965-4538
Gary Swenson
(805) 644-9579

Santa Cruz
Brent Ruhne
Ruhne Racing
(831) 295-8290 mobile

Seattle
Jeff Carson
Marine Servicenter
(206) 383-8618



Visit our website: www.ullmansails.com

2008 PACIFIC CUP AND SINGLEHANDED TRANSPAC FLEET FLYING UK-HALSEY SAILS:

Steen Moller	<i>X-Dream</i>	X-119
Garrett Caldwell	<i>Oceanaire</i>	Tayana 47
Joshua Grass	<i>Summer Moon</i>	Synergy 1000
Rodney Pimentel	<i>Azure</i>	Cal 40
Steve Waterloo	<i>Shaman</i>	Cal 40
Terry Cobb	<i>Mirage</i>	Express 27
Nathalie Criou	<i>Elise</i>	Express 27
Phil Mummah	<i>No Ka Oi</i>	Gib Sea 43
Rob Tyron	<i>Feolean</i>	Valiant 32
Dwight Odom	<i>Na Na</i>	Saga 43
Skip Allan	<i>Wildflower</i>	Custom Wylie 27



Synthia Petroka won Div. D with the Hawkfarm *Eyrie* in the 2006 Singlehanded TransPac. This year she's the Race Chairman.

WE WISH
EVERYONE A
SAFE, FUN, AND
FAST RACE!



NORTHERN CALIFORNIA

451 W. Atlantic, Suite 115, Alameda, CA 94501

(510) 523-3966

Sylvain Barrielle • Cynthia Petroka • Jason Crowson

www.ukhalsey.com • sanfrancisco@ukhalsey.com

LETTERS

and removable windows, creating an indoor/outdoor feel to the raised saloon and galley area. Warm hardwood floors complement the clean, airy-feeling interior.

The boat had been built in '01 for Scott Meyer, and he and his family had spent 2.5 years cruising Australia and the South Pacific. They eventually brought the boat home to San Francisco. Anyone interested in this boat should check out Scott's website at www.summ.org, where he's done an amazing job of detailing the features of the F-41 and explaining the pros and cons of the design. For me, Scott's website was an incredible treasure of information.

I can't think of a major purchase that is more complicated and stressful than that of a cruising boat. First of all, they are insanely expensive. Plus, you must become an instant expert in assessing hull integrity, rig stability, and the condition of thru-hulls, rudders, keels, electronics, sails, anchor gear, plumbing, engine, and electrical systems. And wait — all of these assessments could mean the difference between life and death. It's crazy. Having Scott's very detailed review of his boat and his account of how she behaved in his Pacific crossing was immensely helpful. I poured over the pages, making notes and lists of questions. Eventually, I just pulled the trigger and made the best decision I could — which was buying the boat. Since owning the boat, I have come to appreciate the design and quality of workmanship that went into *Endless Summer*. To me, she is beautiful in an all-about-function way — and fun as hell to sail.

During this time, I was also blessed by meeting a wonderful woman named Manjula. Among other things, she is a natural sailor. One day it was blowing over 40 knots, and I was trying to decide if we should go out and practice some rough-weather sailing. "If we go out there, you're going to get cold, wet, and scared," I told her. Her reply was, "I might get cold and wet, but not scared."

The real test came on this year's Doublehanded Farallones Race. It was very rough, but Manjula was a total trooper. On the way in, she drove the boat as we surfed to 20 knots under a double-reefed main and a jib. She likes how fast *Endless Summer* sails. I feel very fortunate to have found a life companion who is willing to share my cruising dream.

So here I am, 42 years old, semi-retired, the owner of a fast, fun cat, and spending my time getting ready for my first cruise. I plan to join the Ha-Ha this fall, spend about six months



'Endless Summer' at the start of the Singlehanded Farallones Race.

cruising Mexico, then figure out what to do next. My dream is to continue cruising and exploring Mexico and Central America, and then hopefully move on to Ecuador. I've already been to the Galapagos Islands, but would love to visit aboard my own boat. After that, I hope to continue through the South Pacific to Australia, and eventually Indonesia, a place I've already been twice.

Through all of the learning, *Latitude 38* has been at the center, providing inspiration, information, and access to the

COURTESY ENDLESS SUMMER

CALL FOR COUNTER-SEASON SPECIALS!

Yacht at Rest, Mind at Ease

WWW.YACHT-TRANSPORT.COM • 1-866-SHIP-DYT



SAFEST WAY TO SHIP • PREMIER SERVICE FOR ANY YACHT • RELIABLE FREQUENT SCHEDULES • UNIQUE DESTINATIONS • COMPETITIVE RATES

UNIQUE DESTINATIONS • SAFEST WAY TO SHIP • RELIABLE FREQUENT SCHEDULES • UNIQUE DESTINATIONS • COMPETITIVE RATES • PREMIER SERVICE FOR ANY YACHT

PHOTOS BY ONNE VAN DER WAL



WORLD CLASS YACHT LOGISTICS

Dockwise Yacht Transport USA

Telephone +1 954 525 8707

E-mail: dyt.usa@dockwise-yt.com

Dockwise Yacht Transport Europe

Telephone +39 [0]10 278 9411

E-mail: dyt.europe@dockwise-yt.com

Dockwise Yacht Transport France

Telephone +33 493 931 856

E-mail: dyt.france@dockwise-yt.com

Clean Boat Bottoms Today... Cleaner Bays and Waters Tomorrow.



Help keep our bays and waters clean for the boaters of tomorrow.

Introducing Sea Hawk's
New Copper-Free
"GREEN" Antifouling:
Mission Bay



Available at your local boatyard or contact us:



Family Owned &
Operated since 1978

PREMIUM YACHT FINISHES

NEW NAUTICAL COATINGS, INC.

800.528.0997 U.S.A. Only • 727.523.8053 International
contactus@seahawkpaints.com • www.SeaHawkPaints.com

LETTERS

sailing community and businesses of the Bay Area. I truly appreciate the important role your magazine has played during this pivotal time in my life. Thank you. I look forward to seeing you on the water.

Steve May
Endless Summer, F-41 catamaran
San Francisco

Steve — *It's an honor to have been of service, so to speak. Now, for some random thoughts:*

1) *You're the first person, male or female, we can ever recall who came out of a divorce and described dating again as a "nice experience."*

2) *We've always thought the Beneteau 47.3 is a cool-looking and fine-sailing boat. If we were looking at monohulls, she'd be a major temptation.*

3) *People understandably have different reasons for liking boats but, like you, our credo is function over form.*

↑↓ I STILL MISS JANICE WHITE

I read with interest *Latitude's* response to Russell Houlston's letter on his somewhat harrowing experiences in this year's Doublehanded Farallones Race. Your facts are usually correct, however, you made a mistake with the name of the skipper of *Sweet Omega* who was lost in the '82 race. It was Janice White, not Janice Rice.

Janice was an Oregonian who taught me sailing aboard *Sweet Omega* on the Columbia River. She was also an intrepid member of the Mt. Hood Ski Patrol. We climbed Mt. Hood and sailed The River with gusto and a sense of adventure. But Janice was most excited about sailing in the Doublehanded Farallones Race. She trailered her boat from Portland to San Francisco and, before the fateful event, had successfully completed the Singlehanded Farallones Race.

I remember the day she started the Doublehanded Race, and the wild evening/night of El Niño wind and rain when she failed to return. I came to realize then, and still do, that there are some things in our control and some that are determined by the fates. The weather had been forbidding and the forecast was for it to get worse, and her boat was small. The questions have all been asked and there are no satisfying answers. I still miss her.

Carl Kirsch
Sea Horse, Cal 2-29
San Francisco

Carl — *We apologize for the error.*

↑↓ I REPORT IT EVEN IF I DON'T THINK IT'S A FLARE

With regard to the discussion of whether to report what might be a shooting star or a flare, I always report what might be a flare to the Coast Guard — even if I don't think it is. I give the Coast Guard what information I've got, and my opinion of it. My reasoning is that the Coast Guard can use the info in conjunction with anything else they might have, and that they have better skills to decide what it really is.

But if anyone is reporting the position of what might be a flare, they should be specific with their latitude/longitude position. I've always used degrees, minutes and seconds. But one time when I reported what had for sure been a flare — but almost certainly fired from the beach — the Coast Guard couldn't interpret the seconds. They persisted in reading back the position in degrees, minutes . . . and 10ths. Even though I repeatedly emphasized the seconds, I could see their helicopter scanning the erroneous position about one mile away.

ANDERSON'S BOAT YARD



The #1 Boat Yard on the Bay

*All of us at Anderson's
would like to thank
all our customers
for choosing the
#1 boatyard
on the Bay.*

Call now to reserve space for:

- Sprayed racing bottoms
- Custom topside paint jobs
- Complete rigging shop
- Custom metal fabrication
- Electrical installation & repairs
- Engine service and repower

*Come see us
for your
boating needs!*

400 HARBOR DRIVE • SAUSALITO, CA 94965

(415) 332-5432 • (800) 310-5432

Fax: (415) 332-8136

**andersonsboat@pacbell.net
www.andersonsboatyard.net**

 **Interlux**
yachtpaint.com

North times seven.

When performance counts the choice is clear.
Call your nearest North Sails representative.

Sausalito
415-339-3000

San Rafael - Sail Care
415-453-2142

Channel Islands
805-984-8100

Marina Del Rey
310-827-8888

Long Beach
562-795-5488

Costa Mesa - Sail Care
949-645-4660

San Diego
619-224-2424



www.northsails.com

LETTERS

Since then I have acquiesced, and use degrees, minutes, and 10ths, just to avoid missed communications.

Bill Nokes
Someday, Gulfstar 41
Zihuatanejo

Bill — It seems to us, the problem with reporting what might be a flare even if you don't think it's one, is that the Coast Guard would be overwhelmed with such reports, most of which would be false, and not take them seriously. It's the old 'crying wolf' syndrome. You might remember that this is what happened with the original EPIRBs, as 99% of the supposed emergency reports were just false alarms.

As people who sail offshore, we think it's our responsibility, in cases of emergency, to make sure others know that we have a problem. That means we're equipped with one or more VHF's, an SSB, a cell phone, an EPIRB — and yes, probably the least useful of all, some flares. And if it ever came down to the case where we'd fired our last flare, and somebody like us decided that it was probably just a shooting star, we'd blame ourselves, not them. For when on the ocean, it's all about personal responsibility.

↑↓DON'T TALK SMACK ABOUT WESTSAILS

Thanks for including the photo of my Westsail 32 *Tortuga* in a recent *Lectronic*, serving as a sistership for the Westsail 32



Westsail 32s best sail to their rating in a good breeze.

Bag End that Dan and Nancy Chism reported having done half a circumnavigation with in 18.5 years.

Just in case anyone decides to talk smack about Westsails being slow, they should check out the accompanying photo of *Tortuga* that was taken in the New Boreas ocean race a few years ago. We had her surfing downwind with a few bursts of over 10 knots on the way to Moss Landing. Giddy up!

Capt. Randy Leasure
Tortuga, Westsail 32
Half Moon Bay

Capt. Randy — Are we being deceived or is *Tortuga* sailing without a boom?

↑↓DIDN'T A WESTSAIL WIN THE PACIFIC CUP?

In the June 13th *Lectronic*, you ran the following item under the title, *A 40-Year Circumnavigation?*

"We're now in the Seychelles in the Indian Ocean, and have finally crossed the longitude line that means we've done at least half a circumnavigation," report Don and Nancy Chism of the Antioch-based Westsail 32 *Bag End*. "This is no great feat for most people, but it's taken us 18.5 years to get here."

I might be wrong, but didn't a Westsail 32 win the Pacific Cup race from San Francisco to Hawaii once, finishing after everyone had gone home?

Michael Carlson
Planet Earth

Fast Bottoms – Part 2



This isn't the in by 9, out by 5 variety of Fast Bottom. This is your in by Monday, Winner's Circle on Sunday Fast Bottom; your Glide Through the Course Fast Bottom, prepped, sprayed and burnished for a competitive edge. Ask us how our Racing Bottom Package can make your boat faster!

Fine Print: Other factors beyond our control may contribute to race results.



Lift capacity 35 tons

Sprayed Racing Bottoms
Full Painting Service
Fiberglass & Gelcoat Repairs
Rigging Repairs & Installation
Electrical Repairs & Installation
Engine Service & Repowering
Propeller Installation & Tuning
Wood Hull Repairs & Caulking
Teak & Non-Skid Deck Repairs

Call us to schedule your boat!

**Chandlery &
Fuel Dock
Open 7 Days**
Mon – Fri
8 am to 5 pm
Sat & Sun
9 am to 5 pm



**A high-performing,
environmentally friendly
bottom paint!**

(see details on our website)

In Berkeley Marina • 510-843-8195 • www.berkeleymarine.com

Sailing Away?

We build custom
sails to suit your
needs, your boat,
your plans.



Keep cruising with
HOGIN SAILS



- New racing or cruising sails
- Roller furling conversions
- All sails manufactured at our Alameda loft
- Repair and service

In the Alameda Marina at
1801-D Clement Ave., Alameda, CA 94501

510.523.4388

Mon-Fri 8:30am to 5pm
Saturday by appointment only

sales@hoginsails.com
service@hoginsails.com
www.hoginsails.com

LETTERS

Michael — David King's Portland-based Westsail 32 Saraband was indeed the corrected time winner in the '88 Pacific Cup Race. Some might argue that when you race PHRF, every boat theoretically has an equal chance of correcting out first, so what's the big deal? The counter argument would be that Saraband also beat a lot of boats in her class with longer waterlines on a boat-for-boat basis, too. They were: Cal 35, Coronado 34, Crealock 37, Hans Christian 33, C&C 37, Tartan 35, and Pacific 40. The fact that she beat those seven boats on a boat-for-boat basis also means that she finished long before "everyone had gone home."

In the '90 Pacific Cup, Saraband corrected out third overall, but once again won her class, beating the following boats boat-for-boat, as well as on corrected time: Ericson 35, Yamaha 29, Hans Christian 33, Pacific 40, Coronado 34, Hans Christian 40, and Roughwater 45.

What conclusions can be drawn from these results? Pro-Westsail 32 folks will argue that it proves Westsails are faster than a lot of boats of the same waterline length and therefore aren't slow at all. Folks who don't like Westsail 32s will respond, "Yeah, they're faster when the competition sails their boats poorly." We think the truth is somewhere in between. There's the classic axiom in racing that there are "different horses for different courses." Westsail 32s are going to have a very hard time sailing to their rating in events that are upwind in light air and chop. Off the wind in a breeze, they have a much better chance to sail to their rating. But as always, the most important factor in making a boat go is the skill of the skipper and crew.

↑↓ GARMIN HAS NOT CHANGED THEIR EVIL WAYS

I've been cruising around the internet looking at handheld GPS units, as the Magellan I have is a little old and is no longer supported. But as I shopped,



COURTESY GARMIN

Curiously, Garmin handhelds seem to live in an upside down world.

I discovered why I bought the Magellan over the Garmin in the first place. Garmin insists on putting the screen at the bottom of their units and the control buttons at the top. This means the screen is covered by your hand when you're entering data. Is it just me, or does anyone else think it's a very basic and dumb way to do it?

Since I bought my Magellan over five years ago, Garmin has not changed their evil ways. I recently went to their website, hoping to email an inquiry to the company as to why they insist on doing this.

But there was no way to give them feedback. Maybe Garmin doesn't care what potential customers think?

Joanne Jackson
Richmond

Joanne — We have a handheld Garmin GPS 76 that we've used from time to time as a backup to our two main units, but don't ever recall being annoyed by the way the screen and controls are arranged. But since you brought it up, we went to the Garmin website, and you're right, all of the controls are on the top of the units while the screens are on the bottom. While we wouldn't characterize this as "evil," it certainly does seem strange, as working the controls often does block the screen.

As for your complaint that there's no way to provide Garmin

COME VISIT COYOTE POINT MARINA:

The Peninsula's Complete Recreational Destination!



BERTHING

- Slips to 40' available
- 22' inside ties for \$85 per mo.
- Multihull side ties available
- Check out our rates!



FUEL DOCK & PUMP OUT

- Open 7 days per week
- Gas and diesel available
- Check our prices
- Free pump outs



JULY SPECIAL

Stay for the Week on Us*

Make your Reservation for a Free Week Stay

**Call the Marina Office @ 650 573-2594
to make your reservation.**



* Does not apply to Transient Boaters. Boats must have current residency in a Bay Area Marina to qualify and must register at least 2 days prior to their arrival.

**COYOTE POINT MARINA ~ 1900 Coyote Point Drive • San Mateo
650.573.2594**



SAILTIME
FRACTIONAL SAILING

You do the Sailing
WE DO THE REST



In association with  HUNTER

Join SailTime today and exclusively sail a brand new Hunter sailboat a minimum of 7 times a month

- Sail a new Hunter just like you own it
- Guaranteed minimum 7 sailtimes per month
- Unlimited 'as available' usage
- Easy online scheduling
- All inclusive monthly fee
- Electronic check-on/check-off
- Sailing instruction available
- No long-term commitments

NOW 3 BAY HOMEPORTS!
Sausalito
San Francisco
Emeryville

Call 877-SAILTIME today to discover more

...when all you want to do is sail!

California Channel Islands Monterey
Newport Beach San Diego San Francisco

and further SailTime bases Worldwide

www.sailtime.com

LETTERS

with feedback on such matters, in their 'Contact Us' section on their website, they write "We appreciate your business and value your feedback. How may we help you?" And while they have 11 categories under which to contact them, you're right again, none of them is really appropriate for the "feedback" they claim to want and you want to give them.

We think Garmin is a fine company that produces many excellent products. Nonetheless, we think both your observations are valid.

↑↓ I'M JUST GLAD BABY BIRDS DIDN'T FALL OUT

After reading the June *Latitude* cover to cover on the Saturday after it came out, I took my boat out on Sunday. Imagine my surprise when I hoisted the main — and was showered with a bird's nest and a couple of little eggs that broke in my cockpit. This after just reading about a similar thing happening on *Profligate*. I'm just glad that baby birds didn't fall out of the sail.

Gregory Clausen
Wisdom, Santana 30/30
Marin County

↑↓ BETTER CHOICE AND PRICES IN BANDERAS BAY

We recently had a great exchange with Christian Mancebo regarding the Nayarit Riviera Marina's slip rates for this fall and winter, and it looks as though they'll be doing a 180° turn in their pricing. He quoted us a 35 cents/foot/day rate for October, which is 15 cents/foot/day less than Paradise Village, and he said that, once the season starts, the Nayarit Riviera Marina will be very competitive with Paradise Village. We think that might make a lot of boatowners happy.

John & Gilly Foy
Destiny, Catalina 42
Alameda / Punta Mita

Readers — Perhaps the greatest evidence that price does matter to boatowners is that Paradise Marina is now, during the off-season, running at nearly 100% occupancy, while the Nayarit Riviera Marina, which opened with significantly higher rates, is operating at something like 10% occupancy. Nayarit Riviera Marina Manager Mancebo tells us they are also working on other ways of attracting boatowners. For instance, they are awarding a perpetual trophy to the first Ha-Ha boat of the year to move into the marina. Last year it was won by Bill Thomas' Vallejo-



↑ ELECTRONIC / RICHARD

Mancebo hopes to have Philo Hayward and others playing live music at the breakwater theatre during the upcoming season.

based C&C 30 Capt. George Thomas. In addition, the marina is in talks with Philo Hayward of Philo's Bar and Music Studio to hold Wednesday night concerts in the amphitheater that's built into the marina breakwater. They are also thinking about addressing the serious problem of not having a pool by putting one in, along with a snack bar, at the entrance of the breakwater, a spot that



HAULOUTS 20' to 80'

HAULOUTS ON SHORT NOTICE...CALL US!



NORTHERN LIGHTS

GENERATOR SALES & SERVICE

WUGGER

MARINE ENGINES SALES & SERVICE

YOUR NEW FULL SERVICE
VOLVO PENTA
DEALER IN THE BAY AREA

PETTIT
marine paint

Sea Hawk
PREMIUM YACHT FINISHES

FULL SERVICE BOATYARD:

- ✓ COMPLETE PROPELLER SHOP
- ✓ ELECTRICAL REPAIR & INSTALLATION
- ✓ FIBERGLASS BLISTER WORK
- ✓ LPU PAINTING
- ✓ COMPLETE MACHINE SHOP
- ✓ SHIPWRIGHTS - CAULKING & CARPENTRY
- ✓ GAS & DIESEL ENGINE SERVICE
- ✓ MAST & RIGGING REPAIR
- ✓ SANDBLASTING & EPOXY COATINGS
- ✓ FIBERGLASS & GELCOAT REPAIRS
- ✓ USCG CERT. WELDERS - STEEL/ALUMINUM
- ✓ INSURANCE WORK WELCOME

88-TON TRAVELIFT HANDLES UP TO 23' BEAM!

Online reservations now available at www.baymarineboatworks.com



1-800-900-6646
(510) 237-0140 • Fax: (510) 237-2253

STEVE TAFT, MANAGER

310 WEST CUTTING BLVD. • POINT RICHMOND, CA 94804



Not Using Your Boat?



**STORE
IT**

Want To Sell Your Boat?



**STORE
IT**

Want to Dry Out Your Boat?



**STORE
IT**

Leaving the Country?



**STORE
IT**

Want to Save Money?



**STORE
IT**

**DRY STORAGE
\$3.75/ft
Power & Sail**



CELEBRATING OUR 50TH ANNIVERSARY

NAPA VALLEY MARINA

1200 Milton Road • Napa, CA 94559

(707) 252-8011 • Fax (707) 252-0851

www.napavalleymarina.com

Marina • Boatyard • Chandlery • Brokerage

Dealers for
YANMAR

Interlux
yachtpaint.com

Distributors for *Brownell*
Boat Stands

LETTERS

would afford a great view of the bay and mountains. We think these are all great ideas.

Of course, nobody should forget that Emilio Oyarzabal Garcia, Director General of Marina Nuevo Vallarta, has told us he expects many of the 230 slips — at what will be an entirely rebuilt and vastly upgraded Marina Nuevo Vallarta — will be ready by the start of the winter season, and that they intend to be very competitive with their pricing.

If things work out, mariners will have more and better choices in Banderas Bay — perhaps the best sailing area in Mexico — than they've had for years.

↑↓HOW FAST WILL YOUR CAT JUMP?

I'm attaching a photo of the GPS we installed in Puerto Vallarta last January, shortly before heading back down to Panama and into the Caribbean again. In May of this year, we were making the passage from Panama's San Blas Islands to Cartagena, Colombia, and enjoying a 10-knot-reach breeze in what were just wonderful sailing conditions. We knew there was a slow-moving low in the area, but there hadn't been any squall activity.

But at midnight there was a sudden blast of cool air, and *Little Wing* started to accelerate. She got going so fast that there was spray everywhere, and we cut the crests of waves with the crossbeam as we bore away. The velocity just kept increasing, so there was no time to shorten sail. What a rush! It would have been much more pleasant, of course, had it been daylight, and had we not left the port open that allowed spray to drench a computer.

I remember seeing the speed predictions that Morrelli & Melvin did for a cat of theirs that was similar in size and displacement to my *Little Wing*. Their predicted top speed of 32 knots seemed a little farfetched to me, as in my experience, we'd been able to hit 18 knots easily but found that it had been very tough getting over 20 knots. But on that night in the Caribbean, with just a main and headsail, we almost effortlessly



'Little Wing's GPS showed a top speed of 29.5 knots. Not bad for a true cruising cat.

bested our previous high speed of 23 knots. And mind you, that mark had been set in 37 knots of true wind while carrying a massive 4,300 square feet of sail. With that sail configuration, *Little Wing's* bow was down, her stern was up, and I felt we were right on the edge. But this time, with just the main and a regular headsail, we had much better control and, as the photo of the GPS shows, hit 29.5 knots, and thus were going much faster.

P.S. Unlike in the Banderas Bay Blast last December, we'd had our bottom cleaned before leaving the Hollandes Cay, so it was no longer like a shag rug.

John Haste
Little Wing, Perry 52
San Diego / Colombia

Readers — Wow, that's moving! We can't help but wonder if any of Bob Perry's designs have ever sailed as fast as his

THE FINEST SAILS BEGIN WITH THE BEST SAILCLOTH

Our patented woven Vectran® sailcloth performs like the laminates with the durability of Dacron®, especially in roller furling applications. In fact, Vectran® is lighter, lower stretch, and retains its shape over a longer life than any sailcloth we've ever offered to cruising sailors. That's because Hood Vectran® is woven, not laminated to Mylar® film. And you can be sure that each sail we roll out is built by hand, with the same care and craftsmanship that has been the Hood hallmark for 50 years. To discuss your sailcloth needs – whether our state-of-the-art Vectran® or our soft, tight-weave Dacron® – give us a call today.

HOOD Sails & Service

HOOD New Sails

HOOD Sail Repairs

HOOD Furling Conversions

HOOD Pickup & Delivery

**Outbound Yachts
New Outbound 52
with Hood Vektron
Vertical Full Batten
In-Mast Furling
Mainsail and 135%
Vektron Genoa**

**PHOTO COURTESY
SWIFTSURE YACHTS**

HOOD
SAILMAKERS

HOOD SAILMAKERS 466 Coloma Street, Sausalito, CA 94965

Call Robin Sodaro (800) 883-7245 (415) 332-4104 Fax (415) 332-0943 hoodsails@aol.com

Visit our website for Special Online Discount Pricing... www.hoodsailmakers.com

LETTERS

52-ft Little Wing, which, make no mistake about it, is a full-on cruising cat. As a result of Little Wing's tremendous burst of speed, we got on *Lectronic* and asked the owners of other cruising cats to report their top speeds. Their responses appear below.

↑↓TOP CAT SPEEDS

In the June 4 *Lectronic*, you asked owners of cruising cats to report their top speeds. My *Eclipse* was only 32 feet, so we never hit 29.5 knots like John Haste did with his Perry 52 *Little Wing*, but we did hit 21 knots with her shortly after she was launched and before I started using her as a liveboard cruiser. Later, we hit 16 knots while crossing the Atlantic. We then sailed the 60-mile-long north coast of Puerto Rico, anchor to anchor, at an average speed of nine knots, something we repeated on a 60-mile stretch of the north coast of Cuba. Both of those passages were under autopilot. As veteran sailors know, the peak speed of any passage is usually near double the average speed on that passage.

However, I must say that I was even more pleased with *Eclipse's* windward, rather than offwind, performance. This was most notably true in the 60-mile '02 Round the Island (Isle of Wight) Race in England, an event that attracted 1,700 entries, 50 of them multihulls. My cat was the only cruising catamaran to stay in contact with the Farrier trimarans and, in fact, we even beat a couple of them. Our start was 10 minutes before that of the high-performance Mumm 30 monohulls. I was somewhat surprised that they caught up with us on the run, and we rounded the leeward mark in the company of three of them. But then, much to their surprise — and disgust! — we overtook them on the beat home, despite the fact that, unlike us, they weren't carrying a dinghy in davits. By the way, I had a journalist aboard from *Practical Boat Owner* who can confirm this story. So who says cruising multihulls don't go to windward?

We're currently sailing our 25-ft Merlin catamaran in British Columbia. We've raced her with some success, and have cruised her when the weather has allowed. I've also been doing some racing aboard *Bad Kitty*, a 25-year-old, 35-ft one-off catamaran that was designed by Karl Utoff. We finished first in the Cape Flattery Race, just beating the F40 *Dragonfly*

— which admittedly had a terrible race. But again, the best part was overtaking performance monohulls such as Santa Cruz 52s and the Wylie 70 ULDB *Rage*



COURTESY ECLIPSE

Although Richard Wood's true cruising cat was only 32 feet, he got her up to 21 knots.

to windward in light winds. And yes, we do have a video to prove it. So again, who says cruising catamarans don't go to windward?

Jeti Matzke of Oakland and I recently bought a new — to us — cruising catamaran, *Bombay Duck*, which is a 34-ft Romany design of mine. This is to replace our much-missed *Eclipse*, which you'll recall we abandoned in a Tehuantepecker. Our new cat is currently located in Virginia. We plan to cruise her in the Bahamas this winter, then probably head

**ATTENTION CRUISERS!
MEXICAN LIABILITY INSURANCE ONLINE**

MARINERS
GENERAL INSURANCE GROUP

Now with six offices offering you local insurance service and global insurance coverage.

SEATTLE
Joe Cable
(800) 823-2798 • (206) 281-8144
Fax (206) 281-8036

NO. CALIFORNIA
(800) 853-6504 • (650) 373-0595
Fax (650) 548-1585
email: boomeins@aol.com
Lic. # 0A99058

L.A./ORANGE COUNTY
Craig Chamberlain
(800) 992-4443 • (949) 642-5174
Fax (949) 642-0252
Lic. # 0D36887

SAN DIEGO
Henry Medina
(800) 639-0002
Fax (619) 226-6410
Lic. # 0A96346

BRADENTON, FLORIDA
Jerry Norman
(800) 914-9928
Lic. # E051940

New!
PUERTO VALLARTA
(949) 274-4111

We insure racers and cruisers all over the world with prompt, reliable service.
www.marinersinsurance.com

ASK ABOUT OUR NEW RACING SAILBOAT PROGRAM!

It's a Mariner's Fact:
Mariner's General Insurance insures cruising sailboats all over the world... are you heading out?



Hunt Yachts

Yacht Sales & Service



FEATURED LISTING

See us at the
**San Diego
Summer Show**
July 24-27



40' Delphia

Sail Away Price ~ \$219,000

2000	55'	Fairline Squadron, <i>Spellbound</i>	\$675,000	2005	40'	Raider RIB, <i>Surf Raider</i>	\$272,500
2000	53'	J/160, <i>NovaKane</i>	\$689,000	1980	40'	Sun Harbor, <i>Bridget</i>	\$39,900
2002	47.7'	Beneteau, <i>Flying Shadow</i>	\$264,900	2006	37'	Delphia	Base price \$152,127
2000	46'	Moody CC, <i>Amadeus</i>	\$376,000	2003	36.7'	Beneteau 36.7, <i>Fandango</i>	\$134,900
2006	45'	Renzo Coupe 4.5	Call for pricing	2002	35'	J/109, <i>Duster II</i>	\$222,000
1987	42'	Hinckley SW, <i>Alcyone</i>	\$297,800	2002	35'	J/105, <i>Cheetah</i>	\$115,000
2005	42'	Renzo PT Runner 4.0	Call for pricing	2002	35'	J/105, USA523	\$138,900
2006	42'	Renzo Express 4.0	Call for pricing	2007	33'	Cross Current, <i>Electra</i>	Sold
2006	40'	Renzo Coupe 4.0	Call for pricing	2007	33'	Delphia	Base price \$130,823
2006	40'	Delphia	\$219,000	1984	32'	C&C, <i>Intrigue</i>	\$54,900
1999	40'	J/120, <i>Blew Bayou</i>	Sold	1998	29'	Luhrs, <i>Blue Pearl</i>	\$87,000
1998	40'	J/120, <i>Scamp</i>	\$205,000	2005	28'	Alerion Express, <i>Bill of Sail</i>	\$89,000
1999	40'	J/120, <i>Blue J</i>	\$217,500	2007	25'	Hunt Harrier	\$159,000
2002	40'	C&C 121 Xpress, <i>Anasazi</i>	\$215,000	2007	22'	Raider RIB	\$49,690

Sell your boat with us. We are always looking for quality listings.



Yacht Sales & Service

2330 Shelter Island Dr. #106
San Diego, CA 92106
(619) 224-6200
FAX: (619) 224-6278

Jeff Brown John Bohne Roy Bream

www.jk3yachts.com



YACHTWORLD.com



**SOUTH
BEACH**
H·A·R·B·O·R

South Beach Harbor is a great way to experience San Francisco. Boats of all sizes are welcome in our protected deepwater harbor. Bring your boat to South Beach and enjoy all the attractions of the city.



- Two guest docks for boats up to 125'**
- 20 guest berths up to 50'**
- Casual and fine dining nearby**
- Adjacent to AT&T Park**
- Easy access to transportation**
- 24 hour security**
- Free pump-out stations**



For Reservations:
415.495.4911 (x0)
fax: 415.512.1351
sb.harbor@sfgov.org
www.southbeachharbor.com

LETTERS

further south in '09-'10.

When not sailing, I'm building the prototype Strike 18, which is a beach cat/trimaran conversion. I started by buying an old 18 m² Morrelli cat for just \$600, and then spent another \$900 for the plywood and epoxy for the main hull. So, for under \$2,000, we'll have a fast daysailer/weekender.

On an entirely different subject, my non-sailing friends attended the Strictly Sail Boat Show in Oakland a few months ago. They thought the show was nice, but came away without really knowing what to do next if they were interested in buying a boat. It would have helped if there had been a general information stand with a sign that said 'Welcome to Sailing' and provided information on things such as whether you needed to take classes to sail a boat, what was involved with buying a boat, what kind of equipment is mandatory, what sailing clubs there are to join, and so forth. Sort of a dummy's guide to getting into sailing. Maybe they could do something like that next year.

Richard Woods
Woods Designs

Foss Quay, Millbrook, Torpoint, Cornwall, PL10 1EN
United Kingdom

Readers — Anyone interested in small cruising cats may want to check out Woods' site at www.sailingcatamarans.com.

↑↓WE 'FORGOT' TO REEF

I've enclosed a photo of the knotmeter on my Lidgard 43 catamaran *RotKat* after an exhilarating sail from Pier 39 in San Francisco to Sausalito a few weeks ago. We probably hit the top speed near Alcatraz, where I estimate the true wind was in the low 30s. We'd 'forgotten' to reef because it hadn't looked that windy. But that's not a bad speed for a 43-ft cruising cat.

ARJAN BOK



Twenty knots could only be a matter of time.

Arjan Bok
RotKat, Lidgard 43
San Francisco

Arjan — Not bad indeed. For readers who may not remember, Arjan did the '00 Ha-Ha with his much-loved Newport 33 Tiger Beetle, after which he decided he might want a larger boat for cruising. He bought the plans for a Lidgard 43 cat and spent years building it in San Francisco. The result is fantastic, in a very clean, simple and hi-tech way. Bok is a bargain hunter, and managed to incorporate many used items in his new boat. The wheels, for example, were originally on Profligate!



COURTESY RotKat

Lightweight composite construction and a rotating mast mean 'RotKat' is capable of very high speeds.

The result is fantastic, in a very clean, simple and hi-tech way. Bok is a bargain hunter, and managed to incorporate many used items in his new boat. The wheels, for example, were originally on Profligate!

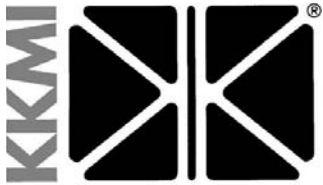

Maritime Yacht Brokerage

☎(510) 236-6633 • fax: (510) 231-2355
yachtsales@kkmi.com • www.kkmi.com
530 W. Cutting Blvd., Pt. Richmond, CA 94804

Ask us about our Maritime Protection Program to find out what a warranty can do for the purchase or sale of your yacht.



Nelson Marek Custom
A 92-ft aluminum world cruiser. Recently repowered. Immaculate throughout and in perfect condition.
\$2,850,000



Dubois Custom 50' (1989)
Custom two cabin cruising yacht designed by Dubois Naval Architects. Exceptionally well thought out cruiser with many details, *Norther* is robustly built, very comfortable and easily sailed short-handed.
Asking **\$529,000**



Sabre 402 (2002)
Awarded *Cruising World's* Overall Cruising Boat of the Year, the Sabre 402 is a perfect mid-size boat for the family or shorthanded offshore cruising. Extremely well equipped with Furlboom, electric halyard winch with all lines leading to the cockpit make it very easy for shorthanded sailing. Asking **\$279,000**



45' Herreshoff Mobjack design ketch
Built by John Clark in Corvallis, Oregon, and commissioned in 1989, this classic Herreshoff wooden ketch took more than eight years to complete. In addition to a well appointed interior and comfortable layout, it has excellent sailing characteristics for cruising in all weather conditions. Asking **\$200,000**



Hinckley Bermuda 40 MkII Yawl CB (1968) Bill Tripp design B-40 is highly regarded for her classic beauty, superb workmanship and many quality details. New sails, new dodger, intelligently updated. Excellent condition.



Fox 44 (2006) Ocelot
Tom Wylie/Kernan Yacht Design sloop-rigged offshore racer. Carbon hull and spars, rod rigging, PBO backstay with full complement of sails, and includes trailer.
Asking **\$325,000**



Santa Cruz 52 (1993)
Beautiful, fast cruiser, set up for short-handed sailing. Maintained to very high standards, the hull has been repainted in stunning red with new bottom paint.
Asking **\$490,000**



Grand Banks Eastbay 38 HX (2003)
Designed by a renowned naval architect, C. Raymond Hunt, and built by a quality yacht builder, the Eastbay 38 HX is a premium cruising yacht in all respects. Extensive factory options, comprehensive electronics, superbly maintained. Asking **\$385,000**



Nordlund 65 (1995)
Custom motor yacht designed for easy operation and comfortable living. Understated and tasteful accommodations in excellent condition.
Asking **\$795,000**



Hatteras 58 (1973)
High quality tri-cabin motor yacht with flybridge. Full displacement with modified V-hull. Completely enclosed sundeck for comfort in all weather conditions. Very well maintained.
Asking **\$269,000**

Emergency Preparedness & Management for Cruisers

Hands-On & On-the-Water Training

Get ready to go coastal!

August 23 - 24

DAY 1

Storm Tactics
Firefighting Exercises
Life Raft Deployment
Flare Practice
PFD Inflation /Re-arm
EPIRB Demonstration
Radio Exercises

DAY 2

Crew Overboard Exercises - with live swimmer
Abandon Ship Exercises
Sea Anchor & Drogue Deployment Exercises



We certify more coastal and offshore graduates than all the other US SAILING schools in the country combined.

Day 1 - \$395
Day 2 - \$695
Day 1&2 - \$995
(savings of \$95!)

Club Nautique

You're at the helm
www.clubnautique.net

Call now to reserve your space
510-865-4700

LETTERS

WE HIT 23.5 WHEN OUR CAT WAS NEW AND LIGHT

Despite carrying just a staysail and a double-reefed main, we hit 23.5 knots in the Med with our Switch 51 *Beach House* when she was new and light. It happened off Cabo Creus at the border between France and Spain, which is also known as the 'Cape Horn of the Mediterranean'. The wind was blowing 30-35 knots, with a few gusts to 40.

We've been cruising for almost a year, and are currently in La Paz. It's hot!

Scott & Cindy Stolnitz
Beach House, Switch 51
Marina del Rey / Mexico

BANJO ANDY PULLED A FAST ONE

When discussing top cruising cat speeds, you noted that, "while high speeds are often possible, they're not necessarily always desirable." Then you continued to say, "As far as we're concerned, hitting the 20s during the day for a few hours isn't bad, nor is hitting 15 during the night. Beyond that, it's more relaxing and comfortable to sail a little slower, thank you." It gave me a laugh because, when we sailed past Isla Cedros before dawn on *Profligate* in the '06 Ha-Ha, I seem to recall that Assistant Poobah Andy Turpin hit 24 knots while the Grand Poobah was sleeping.

My wife Leslie and I will see you on this fall's Ha-Ha, as we'll be sailing down with friends.

Ron Sherwin
Monterey

Ron — Because the wind often funnels down from the tall peaks of Cedros, we always like to be ready for a big increase in wind speed. So when we knocked off that night, we remember giving specific instructions to the crew to keep the boat speed under 15 knots. So there we were in our bunk, trying to get a little shut-eye before getting up and doing the net early the next morning. Every half hour or so we'd glance at the GPS mounted above our berth to make sure everyone was taking it easy. Every time we glanced at the GPS, the boat was within the speed parameters that we'd given. But the last time we peeked, the GPS read a steady 21.5 knots. We bolted out of our bunk, not liking it at all. But once on deck, everything was not only fine, it was great, with the cat sailing as smooth as silk. So the problem is really with us, not the cat.

THE FASTEST PASSAGE BY A GRAY BOAT

In *Lectronic* you reported that the 100-ft ICAP *Leopard* set



'Leopard' starting to show her stripes during sea trials off Australia.

Mari Cha IV, which presumably did not have power-assisted winches.

One would think the power-assisted winches would be

COURTESY LEOPARD 3

BERKELEY MARINA



Centrally located off Hwy. 80 at University Ave. • Fast Access to the Central Bay • Fuel Dock • Marine Center with 35 Ton Lift Capacity • Waterfront Hotel • Restaurants • Adventure Playground • 17 Acre Off-leash Dog Park • Picnic Sites • Deli and More...

Available Berths*

60' Upwind Double, Liveaboard	\$828.40/Mo.	40' Downwind Double, New docks	\$346.80/Mo.
52' Upwind Double	\$554.84/Mo.	32' Upwind Double	\$271.60/Mo.
52' Upwind Double, Liveaboard	\$699.84/Mo.	32' Upwind Double	\$271.60/Mo.
40' Downwind Double, New docks	\$346.80/Mo.	32' Downwind Single, Liveaboard	\$459.56/Mo.
40' Downwind Double, New docks	\$346.80/Mo.	32' Upwind Double	\$314.56/Mo.
40' DW Double Liveaboard, New docks.	\$491.80/Mo.	32' Upwind Double, Liveaboard.	\$459.56/Mo.
40' Downwind Double, New docks	\$346.80/Mo.	30' Downwind Single	\$280.20/Mo.
40' Downwind Double, New docks	\$346.80/Mo.	28' Upwind Single, Liveaboard.	\$404.39/Mo.
40' Downwind Double, New docks	\$346.80/Mo.	28' Upwind Single	\$259.40/Mo.
40' DW Double, Liveaboard, New docks	\$491.80/Mo.	25' Upwind Double	\$217.80/Mo.
40' DW Double, Liveaboard, New docks	\$491.80/Mo.	24' Downwind Double	\$177.12/Mo.
40' Downwind Double, New docks	\$346.80/Mo.	24' Downwind Double	\$177.13/Mo.
40' Downwind Double, New docks	\$346.80/Mo.	20' Downwind Double	\$137.40/Mo.

Berths subject to availability

*all rental agreements & permits subject to approval of application and vessel inspection. Customer responsible for 1st month rent plus deposit, and all applicable fees.

Berkeley Marina Office • 201 University Ave. • 510-981-6740

Visit our website at: www.ci.berkeley.ca.us/marina



Don't Let This Happen To You!

Marine AIS Receivers

Give your navigation software or chartplotter the power to see shipping traffic.

Prices start
from only
\$189!



Why Leave Your – And Your Family and Crew's – Safety to Chance?

Commercial ships now use AIS transponders. Map nearby ships with supported navigation software and chartplotters connected to one of our low cost AIS Receivers.

For more information visit:

www.MiltechMarine.com

Or call us at:

**Milltech Marine
(206) 299-2217**

LETTERS

considered an advantage, and the phrase would only exist on a record that eclipsed a monohull record set by a boat with manual winches. If *Leopard* crossed in a slower time than *Mari Cha*, she doesn't hold a record. Yes, it may have been the fastest crossing by a boat with the advantage of power winches, but it still wasn't as fast as the disadvantaged *Mari Cha* — so who cares? It was probably also the fastest passage by a gray boat, by a boat named after a cat, by a boat with a skipper with initials C.S., and so forth. But again, so what?

It seems like an impressive boat, a top skipper and fast crossing — but not a record.

Jonathan Ogle
Serendipity, Pisces 21
Alameda

Jonathan — Even though we've sailed with owner Mike Slade and captain Chris Sherlock on the previous Leopard, and consider them friends, there is no way we can deny the validity of your argument. It is a little bogus to characterize Leopard's time as a record.

In Leopard's defense, one might argue that 100-footers are sort of the standard of large racing yachts these days, and that few if any of them would have a chance against a boat with a 40-ft longer waterline.

↑↓ IS THAT LINE OF COKE STAINED BLOOD-RED?

I decided to forward the accompanying photo that a friend sent after sailing between Manzanillo and Ixtapa in Mexico. It will help mariners know to expect something unusual — members of the Mexican military wearing masks.

I was told that members of the military wear masks to protect their identity when stopping vessels. The reasoning is that, if they are lucky enough to nab smugglers, they won't be identified, and they and their families won't be threatened or killed by members of the drug cartels. If this seems strange, remember that some of our DEA agents also wear masks when they conduct raids.

I'm told that the members of the boarding party were professional, and didn't mind having their photos taken — with the masks on.

Bill Seals
Planet Earth

Readers — Mexico is in the midst of a very serious battle to determine whether the country will be controlled by a democratically elected government or vicious drug cartels that exist only



BILL SEALS

These masked men aren't Lone Rangers, nor are they members of drug cartels.

because of the insatiable appetite Americans have for controlled substances. We don't know of anyone who objects to members of the Mexico military wearing masks, given that drug cartels are trying to scare off the government by killing as many members of law enforcement as possible, often in the most gruesome ways. So the next time somebody gets

Better Sail Control



now requires less effort...

Garhauer's adjustable genoa car system is the answer to leaving the cockpit and going forward to move the genoa car with every wind shift and sail adjustment.

Experience better sail control with less effort. With four to one purchase, you can now easily control the travel of a block on any track from a single line led aft.

This is a four piece system consisting of two control cars and two end controls (port & starboard). A single line threads thru the two horizontal blocks on the easily-installed track cars for each track. Your genoa sheet slides thru the pivoting vertical block and back to the winch.

Available in track widths of 1 and 1-1/4", built with rock solid durability that all Garhauer hardware is known for.

Now tack better and spend less:

E-Z G-1UB 1 in. track \$242.00

E-Z G-2UB 1-1/4 in. track \$302.50

E-Z G-3 1-1/4 in. track \$363.00

optional swivel cams
available: \$96.80 per pair

for sailboats
25-30' LOA



E-Z G-1UB

Optional
swivel cam on slide

for sailboats
30-36' LOA



E-Z G-2UB

Optional
swivel cam on slide

for sailboats
37-47' LOA



E-Z G-3

Optional
swivel cam on slide



1082 West Ninth Street,
Upland, California 91786

Phone: (909) 985-9993
FAX: (909) 946-3913

email: garhauer@garhauermarine.com
<http://www.garhauermarine.com>

multihulls

classic sails

one design

offshore spec

NEILPRYDESAILS



San Francisco Bay Area
Jim Leech 415 827-1177
Jack D. Scullion 510 919-0001

Monterey Bay Area
Larsen Sails 800 347-6817

Sail outside the box
www.neilprydesails.com

LETTERS

ready to do a line of coke, they might look to see if it's colored by the blood of lots of innocent victims.

↑↓ **SOLAR PANELS ARE A WORTHWHILE INVESTMENT**

The May issue interview with Glenn Tieman, who has done, and is doing, amazing things with primitive catamarans, was fascinating. I was hoping that you could elaborate about two things he mentioned.

First, he said he could receive hourly weather reports from WWVH in Hawaii. What is the least expensive radio for receiving such broadcasts? I thought VHF reception was only good for about 30 miles. Could a sailor receive weather reports from a mainland station for the first half of a trip between San Francisco and Hawaii?

Tieman also mentioned 12-inch by 12-inch solar panels with the "smallest deep cycle batteries." Do you know where these items can be purchased?

Jeff Stump
Indifference, Buchan 37
Kentfield

Jeff — VHF radio is only good for line-of-sight, meaning about 35 miles — except in unusual cases when it can skip hundreds of miles. But they are more expensive than what Tieman paid for his simple radio with shortwave capability. According to NOAA's website, many such radios are available ranging in price from \$20 to \$200. Check the internet. But just because NOAA broadcasts on that site every hour doesn't mean you could pick up the broadcast every hour. Radio propagation isn't that reliable over long distances.

Carrying such a basic radio was consistent with Tieman's simple approach to cruising. Almost everyone else who sails from California to Hawaii would have more sophisticated — and admittedly more expensive — ways to access weather. Among them are SSB or ham radio, which with proper software, could provide text and graphic images of the weather. In addition, those who own satphones could contact professional weather sites for forecasts.

Small solar panels and deep cycle batteries are commodities that you can find in all marine stores and many other retailers. Solar panel technology is improving rapidly, so you may want to look for the newer models. We finally got two of our four 85-watt solar panels hooked up on Profligate, and are very pleased with the results. While she anchored off Catalina, they are keeping the batteries topped up, despite the use of anchor lights, the stereo, the computer and, the most draining, the refrigerator/freezer. We used to have to run the engine about an hour every other day and are now down to running it about an hour every week. When we double our solar panel capacity in the fall, we expect that we'll seldom have to use the engine except for propulsion. There's a sizeable initial investment in solar, of course, but once you make it, the power is free, you eliminate much annoying engine noise, and you leave much less of a carbon footprint. We highly recommend it. And for more ways to lessen your boat's 'footprint', be sure to read 10 Ways to Reduce Your Carbon Footprint starting on page 132.

↑↓ **DOUBLEHANDED BASHING WORKED FOR US**

In *Lectronic* you asked for reports on Baja Bashes this year. We had a surprisingly easy trip from Cabo to San Diego. We even had it good all the way to Morro Bay, after which Pt. Sur gave us a little schooling.

We were late for the big window around April 12, as we'd continued playing around near Agua Verde following the Sea of Cortez Sailing Week. But we left Isla Partida and covered

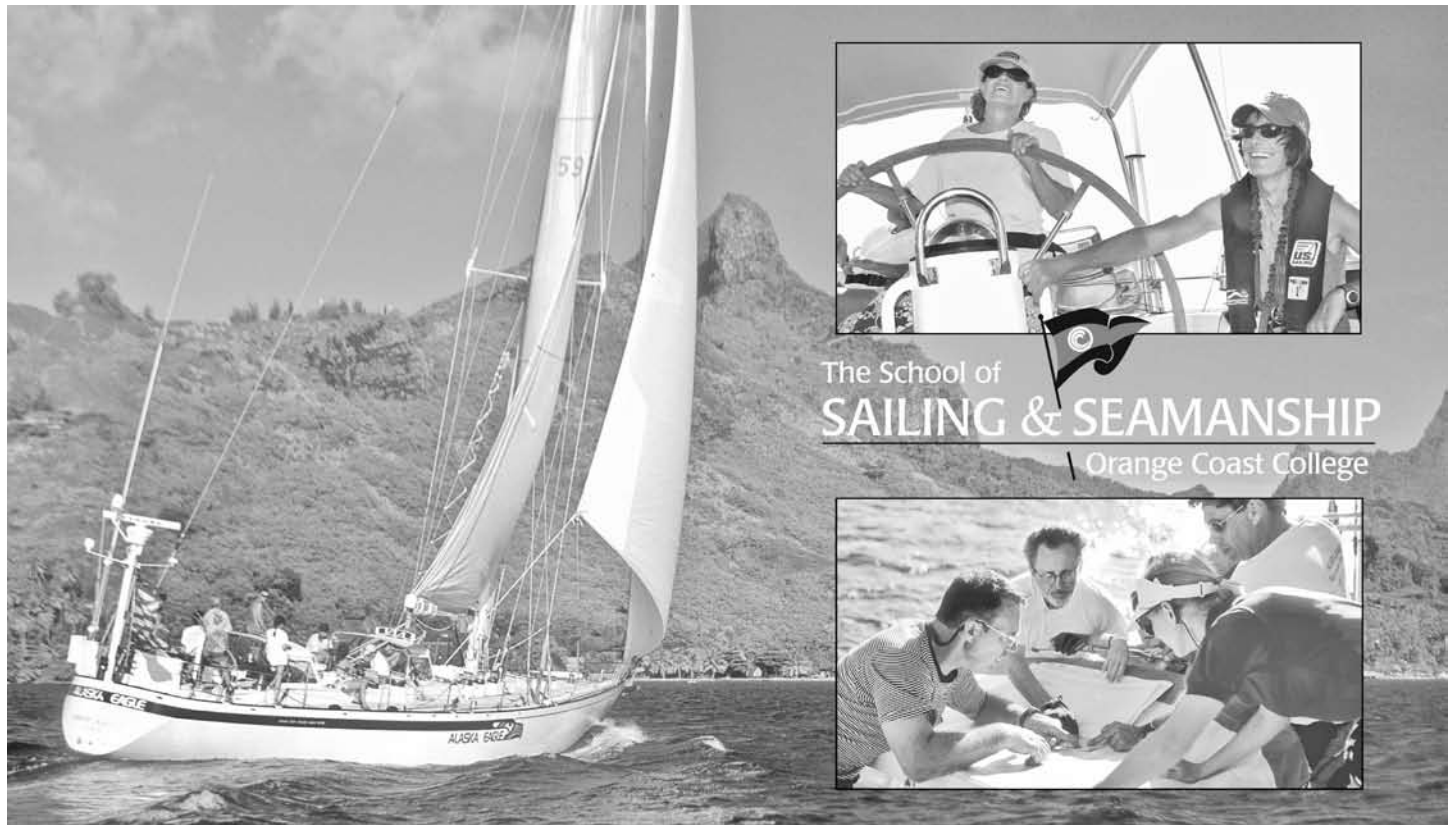

The School of
SAILING & SEAMANSHIP
 Orange Coast College

Make Your First Ocean Passage a Great One

Learn what it takes to make a major cruise under sail during our 24th offshore sail training voyage. Our 2009 schedule offers opportunities for classic passages, shorter coastal trips and participation in long distance races.

Along with eight other crewmembers, you'll sail in all conditions, standing watches and steering as *Alaska Eagle* sails 180 to 240 miles a day. Our emphasis is on helping you build skills in an environment of fun and great sailing. Many who sail with us are planning voyages of their own. There is no better way to prepare.



2009 SKIPPERS
*Sail and
 Learn with
 the Best*

Since Rich and Sheri Crowe sailed *Alaska Eagle* from England to California in 1982, they have been aboard as skipper and mate for the majority of her voyages. Their adventures have taken them north to Alaska, south to Antarctica and everywhere in between. They have so many offshore miles, we've lost count. In their spare time they've built three boats: a 54' aluminum adventure boat and two Farr 44s, virtually by themselves. Their most recent 'vacation voyage' was spent sailing their Farr 44 *Tabu* to Ecuador.

Licenses held: USCG Master Upon Oceans
 STCW International Yacht Master
 (RYA/DOT) • US Sailing Instructor:
 Keelboat, Cruising, Coastal Navigation

ALASKA EAGLE VOYAGE SCHEDULE:

Newport - Cabo San Lucas • 800 miles

March 8 - 14, 2009

Alaska Eagle will be the communications boat for the Newport - Cabo Race

Cabo - Newport Beach • 800 miles

March 17 - 25, 2009

Sailing this coast can be a challenging mix of upwind sailing and motoring with plenty of navigational challenges.

San Francisco - Newport Beach • 350 miles

April (after Strictly Sail Pacific)

Sail under the Golden Gate Bridge and down the coast to a mixture of remote and popular anchorages.

Newport Beach - Hawaii • 2250 miles

June 29 - July 12, 2009

Alaska Eagle will be the communications boat in the legendary Transpac Race.

Hawaii - Victoria • 2500 miles

July 15 - Aug 2, 2009

This classic passage is for sailors who want to experience the freedom of an ocean crossing.

Pacific Northwest Adventure • 600 miles

Aug 5 - Aug 16, 2009

*This women's trip starts and ends in Victoria, BC. Gorgeous landfalls with training in navigation, radar, weather and sailing *Alaska Eagle*.*

Victoria - San Francisco • 800 miles

Aug 20 - Sept 1, 2009

Challenging conditions and rugged beauty make this a great voyage for coastal skill building.

San Francisco - Newport Beach • 350 miles

Sept 4 - Sept 10, 2009

*The last leg on *Alaska Eagle*'s 2009 voyage allows for a nice mix of passages and exploring secluded anchorages.*

To learn more: www.occsailing.com To request a color catalog or specific info: **949-645-9412**

Or write: *Alaska Eagle Voyages*, 1801 W. Coast Hwy, Newport Beach, CA 92663

**"Your full service,
fully stocked canvas super store."**



Matthew Hunt

**Build it
Repair it
SAVE
\$\$\$!**

**Online Shopping, Tips,
Instructions, Product Videos**

Kits



Thread



Tools



**For a free supplies catalog call 1-800-348-2769 or
visit us online at www.sailrite.com**



**1-800-348-2769
www.sailrite.com**

LETTERS

95 miles to Frailes under a full main and poled out jib in just over 10 hours in a mild — 20 knots or so — Norther.

We got to Cabo the following day, and found no boats waiting, as they'd all left in the good weather a few days before. But as the weather was supposed to stay good for another 24 to 48 hours, we provisioned and left at dawn the next morning. We had flat calm all the way from Cabo Falso to about 10 miles from Turtle Bay — which is about half the distance from Cabo to San Diego — and covered it in just 48 hours. We had thick fog most of the way to keep us on our toes.

We spent the whole next day in Turtle Bay, packed up the dingy, davits, and everything else we could, and departed at 5 a.m. Initially, the forecast was for another three-day 'window', but Don Anderson of *Summer Passage* shortened it to about 36 hours. As a result, a bunch of boats that left Turtle Bay with us turned back. But we continued on and made San Diego in 43 hours.

We had a little breeze around San Carlos, but never saw over 15 knots the entire way from Cabo to San Diego, and 90% of the time it was five knots or less. Our Bash took a total of just under six days — including the 48 hours we spent in Turtle Bay.

After a short stay in San Diego — including a side trip to Disneyland — we made it to Morro Bay in just over 48 hours, including a nice overnight stay at Avalon. There were mild Santa Anas, so we rounded Pt. Conception in calm conditions with occasional offshore blasts of warm air! Arguello gave us a short stint of 30 knots, but that was all until Morro Bay.

Making it around Pt. Sur required some persistence. In our first attempt, we departed San Simeon at night in a moderate breeze, but by the time we got to Pt. Lopez at 4 a.m., the wind was blowing a steady 36 knots and gusting to 42. In addition, the waves had a diabolic nature characterized by occasional sidewinders that would really soak down the cockpit. Since it was night, there were only two of us, and the forecast called for a full gale within 24 hours, we retreated to Morro Bay to try again a couple of days later.

During our second attempt we had the same high 30 and low 40 winds at Pt. Lopez but, as it was daytime, we soldiered on through the last 10 miles and dropped the hook at Pfeiffer Cove. You've got to love the name of the beach at Pfeiffer — Shipwreck Beach.

After a roly night on the hook, we left at dawn again, and had high winds in the high 20s and low 30s to Pt. Sur and



ELECTRONIC / RICHARD

"I got you, babe!" Baba and Brendan decided they'd rather do the Bash by themselves rather than adding extra crew.

again to Año Nuevo. But after that, it was mostly 15 knots to San Francisco. Note that on both occasions, the forecast for the Pt. Sur area — Piños to Piedras Blancas — was for 10-20 knots. This seemed generally accurate, except that the Pt. Sur acceleration zone reached 20 miles south of the point and doubled or tripled the wind north of the Point.

All in all, our Bash conditions were much better than ex-

Why settle?



Ballena Isle Marina

Alameda 510.523.5528

Jack London Marina

Oakland 510.834.4591

Treasure Island Marina

San Francisco 415.981.2416

Martinez Marina

Martinez 925.313.0942

You don't settle for less, why do it with your marina? Join one Almar marina and gain access to seven Bay Area marinas. Almar's reciprocal program takes the hassle out of your boating weekend. A simple call to the marina office and you can spend the weekend at Jack London Square or Treasure Island. Maybe a trip to a few of Almar's seven Southern California marinas. We make it so easy you may find yourself using your boat.

Almar boaters receive a 10% discount on any fuel purchase at Jack London Square and Ballena Isle Marina. Jack London Square Marina has just upgraded it's fuel dock with high speed fuel dispensers and now has the fastest pumps in the Bay Area. You don't have to settle anymore.

Almar is the largest operator of saltwater marinas in the country. Almar Marinas provide a wide range of services and programs that few marinas or yacht clubs offer. Some of these programs include: monthly boating seminars, boat handling classes, navigation courses and organized outings to local anchorages. Each marina offers wireless high speed internet access, which can be used with your reciprocal privileges at any Almar Marina. To see the difference, visit one of our marinas this weekend.



almar.com

BLUE WATER YACHT INSURANCE

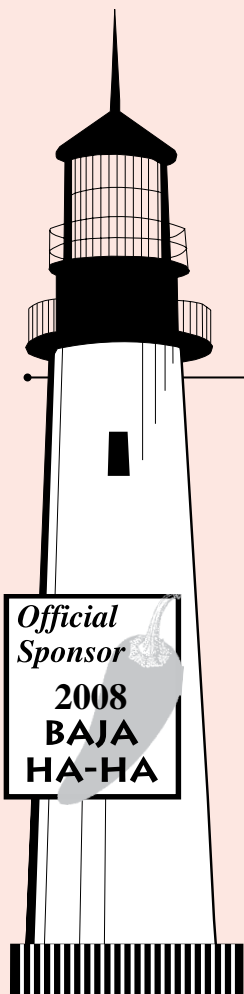

Blue Water Yacht Insurance covers more active cruising boats than any other marine agency in the Western Hemisphere, and is the leading innovator of insurance products for the offshore sailor.

Our Insurance Programs Provide:

- Crew of two anywhere
- Worldwide Navigation
- Hawaii
- Caribbean
- South Pacific
- Charter Boats
- Multihulls
- Liveboards
- Racing Boats

Quality Rated Insurance Companies

Boats aged 1 to 40 years • "Agreed Value"
"All Risks" • "New for Old" replacement partial losses
Hulls valued \$50,000 to \$2,500,000

Worldwide Health Insurance

International and USA health insurance plans
at affordable prices.

Call Toll Free

(866) 463-0167

Fax: (866) 795-3707

sales@bluewaterinsurance.com

Quote requests

Visit our website

www.bluewaterinsurance.com

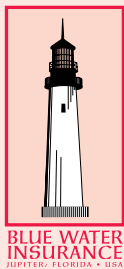

LETTERS

pected, but we did intentionally wait around for good weather, and when we had it, we went straight through without stopping, even though there were only two of us. We made the decision to go with just us, as it allowed us more flexibility with timing. It seems to have been a good decision.

The availability of accurate weather information — especially GRIB files via SailMail and Anderson's radio forecasts — helped make it an easier trip.

Brendan Busch & Baba Muller
Isis, SC52
La Honda

↑↓ IT'S BEEN A TYPICAL BAJA BASH SEASON

It's been rough out there doing the Bash this season because of all the storms in Southern California. In fact, after spending about 20 hours making it up to Mag Bay in late May, I decided to return to La Paz. It was taking longer than I thought, and I was under some time constraints, so I'll try again in July. I'll let you know how it goes.

Axel Heller
XTerra Firma, Formosa 47
Temple City

Axel — Based on the reports we've gotten, it's been a typical Baja Bash season. Those who got good windows, or were able to wait until they got good windows, had pretty easy trips. Those who didn't have the luxury of being able to wait for a window, had every kind of trip imaginable — great, good, bad, or terrible.

↑↓ I HAD A GREAT TIME SINGLEHANDING HOME

After having a great first time cruising to Mexico with the '07 Baja Ha-Ha, we had our daughter Chancy and son-in-law Gabe — he had only been home from Iraq for two weeks — join us in the Sea of Cortez for more great sailing, snorkeling, and diving. But we all had to fly home when my mother suffered a heart attack and passed away a week later.

Having left *Cool Breeze* in San Jose del Cabo, I decided to fly back and do the Bash singlehanded. It took me a total of 11 days to make it to Ensenada, two of them spent on the hook in Turtle Bay.

It was rough three times. Two of them were on the second and third evenings of my Bash. On both occasions, the swells and current became so strong at about 7 p.m., that my autopilot was unable to hold a course. As a result, I was glued to the helm for both nights for about 10 hours. And when I took my eyes off the compass to look at the radar screen for a second or two, I'd be thrown 20° off course.

The third rough time was the first night I was anchored at Turtle Bay, when I woke up at 2 a.m. to find the wind blowing 35 knots and *Cool Breeze* dragging closer to the reef. It was a little hard to keep my bearings as I tried to raise my anchor, when a power outage on shore blew all the lights out. I finally did get the anchor up and was able to motor to the north shore and reset my hook. The shore lights came on about two hours later.

Checking out of Mexico in Ensenada went smoothly. Fortunately, I'd purchased Mexican liability insurance at the Ha-Ha Kick-Off Party in San Diego in October. I didn't think that I'd need a copy of my insurance to clear out, but they made it clear that either I had to go back to my boat to get a copy, or I was going to have to buy a new policy. I did the former. But I was really surprised that I needed to have the insurance to check out.

The next day I checked back into the States in San Diego.

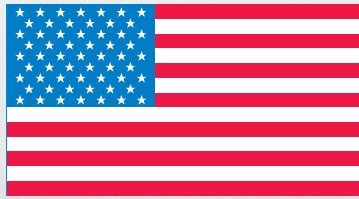

**Along with a great place to berth
your boat, San Leandro Marina
offers you a wealth of
recreational opportunities...**

- **27 holes of championship golf**
- **A waterfront hotel**
- **Fine dining at 2 restaurants
overlooking the water**
- **40 acres of shoreline park and
picnic sites**
- **300 acres of tidal wetlands on the
Bay Trail**
- **2 active yacht clubs**



(510) 577-3488
www.ci.san-leandro.ca.us/slmarina.html

Harken Self-Tailing and Powered Winches

Why Upgrade?



Marten 49, Francolini / Azzura Marine Photo

WINCHES



SELF-TAILING WINCHES

Upgrading from a standard to a self-tailing winch frees your tailing hand and **allows a single person to trim or raise the sails.** Either manage light loads with one hand, or use both hands to deliver more power to a Speedgrip handle.

POWERED WINCHES

The **touch of a button** allows you to sit back while a powered Harken winch does all the work. Upgrading to powered winches lets you **perform high-load jobs effortlessly** and **sail larger boats shorthanded.** In marginal conditions a single electric winch can make the difference between sailing and motoring.

ELECTRIC WINCH CONVERSION

Harken winches made after 1999 **can be converted to electric power** (size 44 and up).



HARKEN
CELEBRATING 40 YEARS

1251 E. Wisconsin Ave., Pewaukee, WI 53072, Tel: 262-691-3320
Fax: 262-691-3008, Email: harken@harken.com, Web: www.harken.com

LETTERS

I made it from San Diego to Bodega Bay in seven days, including a stop in Santa Barbara. I left *Cool Breeze* in Bodega Bay until there was a beautiful weather window a month later. That window allowed me to make a three-day sail up to Winchester Bay, Oregon. The only mishap occurred at 11 p.m. while I was rounding Pt. Mendocino, when the block on the main's outhaul snapped, allowing the foot to fly freely.

I docked at my home port of Winchester Bay at 10 a.m. on May 18, having had a great time. I'm looking forward to a future Baja Ha-Ha, and want to thank *Latitude* and the Ha-Ha crew for that wonderful event.

John Beane
Cool Breeze, Catalina 42
Winchester Bay, Oregon

↑↓IT COULD HAVE BEEN WORSE

Here's our Baja Bash report: Scott from *Adios Pirate* and I left La Paz on May 15, six months after doing the '07 Ha-Ha (our second) and arrived in San Diego 10 days later. We sat out a gale in Turtle Bay for three days, but other than that, had a pretty easy trip.

We fueled up in San Jose del Cabo to avoid entering the Cabo San Lucas madhouse. We were hit with about 30 knots off Cabo at 6 p.m., and it took us two hours to clear Cabo Falso. Several other boats turned back, but we broke out and the wind backed off at about 9 p.m.

We had 25 to 30 knots the next day, and an ugly 6-ft swell. But that let up around dark. After that, we probably didn't see 15 knots at sea for the rest of the trip. As previously mentioned, we did wait out a gale in Turtle Bay.

Vinmar uses a half gallon of fuel per hour at 2,500 rpms. We ran at 2,800 rpms to Turtle Bay and, as a result, used 50 gallons of fuel, quite a bit more than our average. We motored at 2,600 rpm from Turtle Bay to San Diego, and used only 35 gallons.

Customs in San Diego asked for our passports and boat registration, and didn't even step aboard. It took 10 minutes.

Two problems revealed themselves once we were back in our slip in San Diego. First, we had fried the four-year-old batteries by not having a three-stage charger on the engine alternator. Second, we shook crud loose in the fuel system and filled the filter bowl.

The best Bash advice I received — and it came from several different sources — was to keep moving whenever possible and as fast as possible. Several boats left Turtle Bay when we did, but stopped at San Quintin and had a lot worse weather the rest of the way than we did.

A big thanks to Don of *Summer Passage* for his weather information. His forecasts for the gale were spot on.

Scott Haselton
Vinmar, Ranger 33
San Diego

↑↓"WOULD I DO IT AGAIN? HELL YES!"

My wife, Debbie, and two stepsons, Matt and Jake, did the '06 Ha-Ha aboard our Westsail 32 *Sosiego*, and based our 'commuter cruising' out of La Paz. In the spring of this year, Joey, my youngest son, and I, delivered the boat home. We learned a lot about the local weather patterns and how to best tackle a Bash on that trip.

Our first challenge was getting through Customs in the La Paz Airport. Naturally, my bag with the new tiller pilot inside was the one they wanted to 'inspect'. I was taken to an office, and after some 'negotiations', my wallet was lighter.

Our next hurdle was provisioning, which required some

NOW AT SOUTH BEACH HARBOR IN SAN FRANCISCO

Introduction to Fractional Sailing

Member/Sailor Benefits:

- Above average monthly sailing time
- A fraction of boat owner cost
- Brand new Catalina yachts
- No monthly maintenance
- Includes slip fees, insurance
- Convenient slip in San Francisco's South Beach Harbor



All this for only \$575/mo*

**Apply now.
Limited memberships available*

Want to Own a New Catalina at a Fraction of the Cost?

Owner/Sailor Benefits:

- Own a new Catalina today
- Club members reduce costs
- Yacht maintenance managed for you
- Stop dreaming and start sailing!

Owner/sailor needed for new Catalina 320*

**Limited owner positions available.
Apply today.*



Always leave the dock happy.

South Beach Harbor • San Francisco
Emery Cove • Emeryville
Visit us at www.WindPath.com or
Call 510.499.WIND (9463)

Where Can Mariner Take You?

Your Marine Lending Source

PURCHASE/REFINANCE/REPOWER
TERMS UP TO 20 YEARS
LOANS UP TO 100% OF VALUE
LOAN AMOUNTS AS LOW AS \$10,000
FIXED AND ADJUSTABLE RATE PROGRAMS
VESSELS FROM 1979-ON ELIGIBLE



Call Joe for a Rate Quote
(866) 289-0976

www.marinerfinancialsvcs.com

Rates and terms subject to credit and collateral qualification and may change without notice.
Restrictions and exclusions may apply to some programs.



The best sailing gear on the market



Life Time Guarantees

Check out all the great sailing gear at
www.OnLineMarineStore.com

6000 items in one store
same or next day shipping on most

He Who Ha-Ha's First Ha-Ha's Best!

Come to San Diego early for:

- ✓ best guest slips
- ✓ best prices on cruising gear
- ✓ best San Diego service and outfitting

All
San Diego
Marinas
Listed on our
website!

CAN'T COME EARLY?



CRUISE TO OUR EXPANDED WEBSITE

www.downwindmarine.com



**DOWNWIND
MARINE**
THE CRUISER'S CHANDLERY
Cruisers' Net, Ch. 68, from
8:30 am weekdays: **WHX369**

SAVE NOW – CALL TOLL FREE

866-289-0242

2804 Canon St., San Diego, CA

32° 43' 01" N 117° 13' 50" W

Fax: (619) 224-7683

info@downwindmarine.com

Open: M-F 8-5 • Sat. 9-5

www.downwindmarine.com

NEW LOCATION!



Hansen Rigging specializes in quality service and installation of masts, booms, rope and all associated hardware and now has a new facility to serve all our yachting friends even better than before.

*Please stop by to experience the difference
a knowledgeable rigger can make.*

HANSEN RIGGING

(510) 521-7027 • www.hansenrigging.com

2307 Blanding Ave., Alameda, CA 94501
hansenrig@sbcglobal.net

LETTERS

communications with the taxi driver. The fact that my wife is fluent in Spanish has resulted in me relying on her abilities, so my Spanish is beyond atrocious. Wanting to go to the supermercado, I said, "Cuanto cuesta C.C.C.?" I pronounced the name of the well-known store as 'Si, Si, Si'. After much gesticulating, I learned that C's in Spanish are pronounced like 'Say', and therefore the store is 'Say, Say, Say'.

With provisions loaded, anchors stowed, bottom scrubbed, and boat rigged for sea, we made an overnight dash to Cabo San Lucas. We had to motor the entire way because there was no wind. Was our delivery going to be a piece of cake?

In preparation for the trip north from Cabo, I bought and reread a copy of Capt. Jim Elfers' *Baja Bash*. This book is a wealth of knowledge and just plain good seamanship. Joey and I topped off the tanks, then called Debbie, who was to be our weather router for the Bash. She reported a two-day window, so we bunked down early to make a 4 a.m. attempt at Cabo Falso. As Cabo veterans know, the disco music doesn't end until 4 a.m., so sleep was hard to come by at best. We had confused seas at Cabo Falso, but no gusts over 25 knots.

After six hours of 'washing machine' fun, we had a foot on the beach and were making good time toward Mag Bay. I must confess, however, that this was the scary part of the trip for me. A friend had lost his 40-ft ketch on this stretch of coast the previous fall. The pounding had opened up a seam, and he eventually lost a fight with rising water. He lost his boat, but was rescued by fishermen before he had to take to his liferaft. We made it to Bahia Santa Maria — 175 miles north of Cabo — in two days, with the strongest wind being the 20 knots we had on approach to the bay itself at sunset.

With the anchor holding well, my son and I slept like the dead until our planned departure at noon the next day. Despite Bahia Santa Maria remoteness, I had cell phone reception and was able to call Debbie for a weather report. She said the forecast was for building conditions toward the end of the week, but it looked as though we could make it the 240 miles to Turtle Bay.

Points along the coast accelerate the wind, and nothing demonstrated it more to me than what we faced the next two days. In *Baja Bash*, Elfers recommends anchoring in the lee of Abrejos. Instead of taking that advice, we continued on. Oops! For the next 24 hours we averaged one knot an hour to the good, went through five fuel filters, and discovered some leaks in my previously dry boat. Lesson learned!

The next afternoon, we were abreast of Asunción, so we ran in to anchor for the night rather than battling on to Turtle Bay. An old dog *can* learn new tricks! Well rested, we made the hop to Turtle Bay without incident — but just in time. Within hours of our arrival, we were joined by the Mexican tuna fishing fleet, which was also seeking shelter. We spent the next five days having fun with the locals while waiting out gale force winds. My son and I practiced our Spanish with the captain and crew of a fishing boat over a few beers while they practiced their English. By the way, we got the cleanest fuel of our whole trip at Turtle Bay.

Once the weather eased up, we motorsailed for three days and two nights to Ensenada in light winds — nothing over 15 knots — and flat seas. We checked out of Ensenada without difficulty after spending the night tied up next to the *Black Pearl*! How cool is that?

All in all we made it back under the Gate within two weeks of leaving La Paz. We even had a following wind around Pt. Conception, with a pod of whales as an escort. Even better, we were able to sail wing-on-wing from Monterey to the Bay!

Would I do it again? Hell yes! It was a great time to bond

For more than 25 years, yacht owners have been able to trust **PACIFIC COAST CANVAS** for the best in design, service and quality.

• **Offshore Dodger™**

Welded aft handrail
Bolt-on side handrails
Lexan windshields

• **Baja Awning™**

Lightweight and waterproof
Durable and easy to launch
Multiple side screen configurations



Check out the new 'Special Edition' Jeanneau 45, with Dave at Cruising Yachts; with our new offshore dodger.

• **Coastal Dodger™**

Affordable designs
Same high quality materials
Same superior workmanship

• **Cruiser's Awning™**

Easy setup off your dodger
Flies with no bulky frame
Comes with shade screens

Open Monday-Friday 8:00-4:00
Saturday by appointment
(510) 521-1829



**2021 Alaska Packer Place
Alameda, CA 94501
Grand Marina**

Harbor 25

Enjoy Sailing in Style and Comfort
The Harbor 25 is a stunning **NEW** design with classic looks, a roomy cockpit, a beautiful teak interior, and an inboard engine.

W.D. Schock CORP.

Boat Builders · 23125 Temescal Canyon Rd., Corona, CA 92883 · (951) 277-3377 · Fax (951) 277-4104
Website www.wdschock.com

SUMMER SPECIALS

on AVON and ZODIAC INFLATABLES

Cadet Fastroller

Pro Dive Boat

- ☛ YACHT TENDERS
- ☛ PROFESSIONAL DIVE BOATS
- ☛ RIBs & ROLL-UPS
- ☛ LIFERAFTS
- ☛ SALES AND SERVICE

CALL TODAY FOR LOWEST PRICE OF THE YEAR!

Tim's Zodiac Marine
45570 Industrial Place #10, Fremont, CA 94538
(510) 438-9881

NOW AVAILABLE



C. SHERMAN JOHNSON CO. INC.
Johnson
 Marine Hardware

KEEPING YOU CONNECTED FOR 50 YEARS!

Full Line of Hand Crimp,
 Machine Swage and DIY
 Cordage Fittings

**DIY Lifeline
 Fittings**

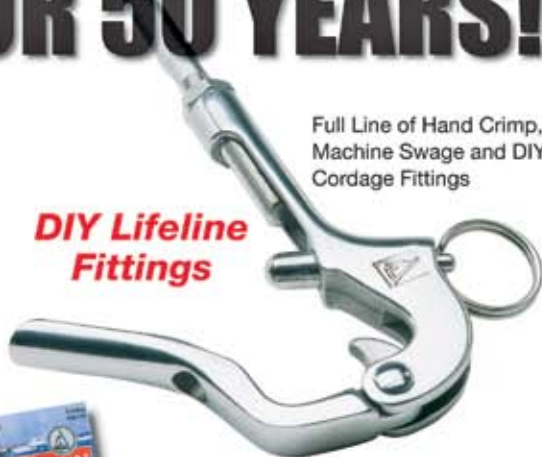

**Unique
 Accessories**

Grab 'n Go™ Hook



**Rigging
 Hardware**

Calibrated
 Turnbuckle



C. Sherman Johnson Co., Inc.
 East Haddam, CT
 1-860-873-8697

www.csjohnson.com

LETTERS

with my son, improve my skills, and meet some of the amazing people of Mexico. I also want to thank the Poobah and everyone else for the fun and memories of a lifetime we got from the '06 Ha-Ha.

Joe & Debbie Graham
 Sosiego, 32 Westsail
 Vacaville

↑↓DONATE TO THE USCG IN HONOR OF JIM GRAY

As many of your readers know, Jim Gray went missing without a trace on January 28, 2007, whilst singlehanded his C&C 40 *Tenacious* to the Farallones to spread the ashes of his mother. As reported by *Latitude* and other publications, an extensive three-week search by the Coast Guard and private individuals resulted in no trace of Gray or his red-hulled sailboat.

Last month, over 700 people, including family members, friends and colleagues, gathered at UC Berkeley to honor and remember Gray, and to recognize his wide-ranging contributions to database design and application. One of the ways Gray's family and friends would like him to be honored is by contributions to the U.S. Coast Guard. During the active search for Jim, and in the months that followed, Jim's family and friends worked closely with Coast Guard and found them to be very caring and amazingly competent. Throughout the search, the members of the Coast Guard were unfailingly polite, respectful, and responsive.

While working with the Coast Guard, Gray's family and friends noticed that certain technological improvements would have helped in the search. For example, if the cameras on the Golden Gate bridge that keep track of boat traffic had higher resolution, they might have recorded a possible attempt by Jim to return to the Bay. Or, if there had been a portable cellphone base station that could be flown during the search, some sign of his cellphone or PDA might have been found.

As such, Jim's widow, Donna, has asked those who want to make a contribution to make it directly to the Coast Guard, San Francisco Sector, for their acquisition of better technology for Search and Rescue operations. This is both as a thank you to the Coast Guard, and to help the next time there is a search.

Donations in honor of Jim Gray may be sent to: USCG Sector San Francisco, Attn: Deputy Sector Commander, One Yerba Buena Island, San Francisco, CA 94130.

Joel 'Not The Weatherman' Bartlett

↑↓VIRGIN'S MASTER HAS SAILED FROM ALASKA

The May *Letters* section featured the usual interesting reading, as it was populated by pirates, jungle boys, and surfers who warmed their wetsuits by illegally urinating within the three-mile limit. The pirates were outwitted, the jungle boys adopted by yachties, and the surfers urged to wear diapers. Woo-hoo!

But Steve Granville from San Rafael won my Golden Tiller award for his comments on the unconventional boat *Virgin*, which he described as a "tragedy" that he wanted to call an "art boat." If it wasn't "a homeless person's mobile quarters . . . at night to be kept away from prying eyes . . . the seaman-like flourishes form a thin veneer on life at its nadir."

Then the vocabularious correspondent Capt. Granville tops his literary survey with a picture of the *Virgin* in all her PVC-pipe, epoxy-covered, spray-on foam glory — despite a sign on the bow that reads 'Do Not Photograph'. I guess spring is as good a season as any to be de-*Virginized*.

Robert, the master of the *Virgin*, hasn't just sailed from

Own a dock on San Francisco Bay! Perfect Location - Great Investment

EMERY COVE
YACHT HARBOR

BUY A SLIP: Save money & earn equity! Save 1/3 of your rental cost. Enjoy big tax savings as a slip owner. Emery Cove Yacht Harbor is the only marina on the Bay with FEE SIMPLE dockminium ownership.
OR RENT A SLIP: 35-60' slips! Rates from \$8.25 to \$9.25.



CALL FOR A MARKETING PACKAGE • 510-428-0505

3300 Powell Street, Emeryville, CA 94608 • www.emerycove.com • Email: info@emerycove.com

COVER CRAFT

It's Only Fitting

that dodgers from Cover Craft have earned a reputation as the best available.



Order now for winter!

- Classic dodgers and biminis
- Wavestopper hardtop dodgers
- Drop-top dodgers for special applications
- Enclosures • Custom canvas

1230 Brickyard Cove Road, #106
Pt. Richmond, CA 94801
In Brickyard Cove Marina

(510) 234-4400

Quality
Yacht
Canvas

CRUISE CONTROLS

MAIN SAIL



**LEISURE FURL®
IN-BOOM FURLING**

- Smooth Operation & Instant Reefing
- Aluminum or Carbon Fiber Construction
- Easily Fitting to an Existing Mast
- Integrated Manual Back-up
- Five Year Limited Warranty

**GENOA
WHISKER POLES**



- Poles Available for boats 16 to 55 Feet
- Aluminum, Carbon Fiber or 50/50 Construction
- Patented Line Control™ or TwistLock™ Adjustment
- Larger Poles Come with Light & Strong Ultra™ Ends



FORESPAR®
MARINE PRODUCTS THAT PERFORM

Ph: 949.858.8820 • www.forespar.com

NEW STORE SAVINGS!



BRING COUPON FOR

EXTRA 10% OFF

Everything you need now in stock
backed by knowledgeable staff.

Free Parking • Expanded Inventory
Convenient Location
Next to Park Street Bridge

expires July 31, 2008



Boston Whaler 110 Sport

With 25 hp EFI Mercury
4-stroke. Great tender.
Great value!

Bristol Finish

Two-part exterior
One-part interior



Honda Yamaha Evinrude Mercury Universal

POWERED BY

**HONDA
MARINE**

**EVINRUDE
E-TEC**

**Universal
DIESEL MARINE ENGINES**

YAMAHA

**MERCURY
Outboards**

Outboard Motor Shop

Where the professionals shop!

(formerly Seapower Marine)

(510) 533-9290

www.outboardmotorshop.com

333 Kennedy St., Oakland, CA 94606 • Fax 510-533-3374

LETTERS

Bolinas, he's navigated all the way from Valdez, Alaska, on *Virgin* and six similar craft. He says the trip began after the *Exxon Valdez* spill on March 24, 1989 — including 543 miles from Chief Joseph Dam to Astoria, Oregon, on the Columbia River. The heavily bearded Robert still dresses like an Alaskan sourdough, and considers himself Amish. He refuses to ride in cars, buses, trains or anything with an engine, and doesn't watch television or movies.

If *Latitude* were courageous enough to speak with him about his many adventures down rivers and oceans, logging more sea time under very challenging conditions than many who call themselves sailors, you could bring a tape-recorder. He doesn't mind those. You can do a painting or charcoal drawing of his boat, too.

After a visit to my Frisco Flyer *Titania* in Richardson Bay, Robert valiantly paddled against 45-knot winds trying to avoid being sucked out the Golden Gate again. I thought to myself, "There goes a guy with the guts of a sea warrior."

If the American Way of Life were more like Robert's and the Amish, existence would be sometimes uncomfortable. It would also be freer of oil addiction, inequality, ecological suicide, climate change, and war fevers.

The seaworthiness of a boat can't be measured by the varnish or the reflection of a well-fed, shaved face in the brasswork. However distorted that reflection, it's still more truthful than judging another without talking with them first — no matter how different they appear.

Jeff Chase
Titania, Frisco Flyer
Richardson Bay

Robert — Members of our staff have considered visiting Robert, but have found him to be somewhat unapproachable. But if he wants to follow the Amish way of life, we've got no problem with it.

Just to bring non-Amish readers up to speed, perhaps the two core Amish values are the rejection of pride and the willingness to submit to God — which also means a reluctance to assert oneself in any way. Being Amish is all about conforming to the group norm. This anti-individualist bent is, of course, totally in opposition to the classic American — and seafarer — outlook. It's also the rationale for rejecting labor-saving technologies, such as electricity and roller furling, as they would make one less dependent on the community. The fear is that this could lead to things like vanity and status goods — such as photographs. It's also the general reasoning that explains why the Amish are against education beyond the eighth grade.

For what it's worth, we at Latitude believe in almost everything the Amish don't — individualism, self-reliance, education, and technology. Sure, we've found the American Way of Life to be wanting in some regards . . . until we compare it with everything else that is available.

↑↓ ARGH, THAR BE PIRATES IN THESE WATERS

I was called out of class by the sheriff, who instructed me to call the Coast Guard immediately. I did. The Coast Guard told me that they had my *Santana* 22 at Yerba Buena Station, and that I needed to come and get it that day. They apparently had picked her up drifting around the Bay Bridge. "WTF?" I thought to myself.

I ran out of class and rushed to the marina, where I have my real boat, and left for the station to retrieve my 'dinghy'. When I arrived, the Coasties at the station were very professional and helpful. In fact, I couldn't believe how nice they were. I'm not one for big government — or for government



Raymarine®

E-Series. Re-Loaded.
New v4 Software, Re-Loaded with
new features and performance

Raymarine's most powerful multifunction displays now re-loaded with new features and improved performance. The new v4.29 software expands E-Series capabilities with support for HD and Super HD digital radar, *Platinum+* charts, Sirius satellite radio audio tuning and more!

Bring your E-Series display to Star Marine Electronics in July for a FREE SOFTWARE UPGRADE with the purchase of a Navionics *Platinum+* chart card.

Purchase a new Navionics *Platinum+* chart card and get up to \$100 for your old chart from Navionics.

Star Marine
ELECTRONICS

Visit Our Showroom At
 333 Kennedy St. • Oakland, CA 94606
510-533-0121
www.starmarineelectronics.com



VALLEJO YACHT CLUB



info@vyc.org

<http://www.vyc.org>

***Now Accepting New
 Membership Applications!***

Individual, Family, Young Adult, Juniors, Students
 and Crew Membership Available. No Boat Required.

*Stop in for a visit during Friday Night Happy Hour
 5:30 PM - 8:30 PM during July and August*

485 Mare Island Way, Vallejo, CA 94590
(707) 643-1254

ELLIOTT / PATTISON SAILMAKERS



PHOTO: GERI CONSER



870 Production Place
 (949) 645-6697
 Newport Beach, CA 92663

Order now for Pacific Cup Delivery

Oceanside
 Lee Pryor
 760 529-0062

Marina Del Rey
 Doug Johnstone
 310 528-2146

LA Harbor Area
 Steve Dair
 310 619-7245

SPEED DATA 100% ACCURATE ULTRASONIC SPEEDO



100% COMPATIBLE
with all
electronic brands!

» Standard transducer size is interchangeable with your current sensor.

» Flush, Fast, and Precise! Speed always available, guaranteed.

Forget the problems with your current paddlewheel and get comfortable with a sensor that is maintenance free.

Get the sensor that is linear and exact! Speed is the fundamental basis for all performance data on your boat; you no longer have to settle for spotty/intermittent data.



nke offers displays and sensors for your boat that are tested and proven in the harshest environment on earth.

nke

MARINE ELECTRONICS

In service and at your service all over the world! www.nke.fr

U.S. Representative
Euro Marine Trading, Inc.
62 Halsey Street, M – Newport, RI 02840
www.euromarinetrading.com

LETTERS

at all, really — but these guys were fantastic. They even had me wanting to join the Coast Guard Reserve. But my distaste for people barking orders at me won out, and I have not yet enlisted. But I digress.

When I got to the dock, I asked what had happened. They told me they'd gotten a call that there was a boat floating aimlessly around the eastern towers of the Bay Bridge — where all the construction and barge traffic is — and so they picked



CAPT. TEDDIUS MAXIMUS

A lot of stuff at the bottom of Clipper Cove could cause an anchor rode to part, but above the waterline?

it up. Strange, I thought. I had the Santana securely on the hook in Clipper Cove for the week. And I know how to set a proper anchor. I walked over to my boat, and I immediately noticed something odd. The remaining two feet of anchor rode was clearly cut — not frayed at all. It was obvious to

my eyes that the line had been cut. And to the eyes of the Coasties, once I pointed it out to them.

I know that I shouldn't have expected otherwise, having left my boat unattended for a week or more on the hook, and especially with my already stated inclination towards lawlessness. I guess I was hoping that piracy was not the name of the game in these waters. In fact, it has been quite the opposite of my San Francisco Bay experience. My Santana 22 is not particularly valuable, nor was anything in her. And nothing seemed to be stolen. I guess the spot my boat had been occupying was the plunder that the culprit(s) were after, or perhaps just some sense of malicious gratification.

My Santana is now safe in a marina, undergoing an overhaul, and all is well. A hearty thanks of appreciation to the Coast Guard for softening the brine in my politics. And to the scurvy rats that cut my line, I'll come to collect my bottle of rum, Pusser's please, and take your apologies — lest you extend this invitation to join you in the world's second oldest profession, in which I am equally capable and willing to play.

Avast ye that ply the Bay of the Golden Gate, for there be pirates in these waters

Capt. Maximus
Pacific Coast and Ocean

Capt. Max — Modern life being what it is, leaving a boat unattended often leads to unintended consequences.

As for the "world's second oldest profession," we checked the internet, and there were no less than 34 candidates, from vintner to accountant. What's your nomination?

IT'S GOT TO STOP

My idea for stopping the theft of items for their scrap metal value — such as reported in June's *Sightings* — is to require scrap yards to hold the items turned in for a week to 10 days, withholding payment as well. This would allow items

THERE'S A NEW SHERIFF IN TOWN

Rated "EXCELLENT"
& "BEST BUY"

Powerboat Reports®
2004, 2005, 2006, 2007



BLUE WATER® MARINE PAINT

KKMI® is pleased to promote Blue Water™, rated "EXCELLENT" by Powerboat Reports®. Blue Water™ contains higher concentrations of premium domestic copper & active ingredients, and only use virgin rosins, colorants & solvents in all antifouling. Blue Water™ is the only distributed marine paint that offers a 1-year written warranty against premature hard marine growth.



COPPER PRO SCX 67 HARD™ FULL SEASON - 67% COPPER - BOOSTED MODIFIED EPOXY

Blue Water® Copper Pro Scx 67 HARD™	\$199.99	★ \$40 / gal Savings
Pettit® Trinidad SR™	\$229.99	
Interlux® Ultra with Biolux™	\$239.99	



530 West Cutting Blvd.
Pt. Richmond, CA 94804

(510) 235-5564
KKMI.COM

FridgeFreeze THE ICE AGE IS OVER!™

Portable 12/24 and 110-volt refrigerator/freezer



- * Super low amp draw
- * Will freeze or refrigerate in over 110 degree heat
- * Made for the marine environment

FridgeFreeze, Inc.
5343 Banks Street • San Diego, CA 92110
(619) 220-6003

www.fridgefreeze.com



Got Shade?

- Ingenious, self-supporting awning system, attaches to lifelines
- Tall enough to walk under at cabin, no limbo
- Bombproof construction, easily sustains 25 knots
- Sets up in 10 minutes, stows complete in its own 10" x 36" bag
- 10 standard sizes fit any boat, catamarans too
- Prices from \$300.00 to \$700.00

Visit: www.intheshd.com

ShadeTree
888-684-3743
shadetre@gulftel.com

shadetre 
Relax Under A ShadeTree

Relieves Gas Pains

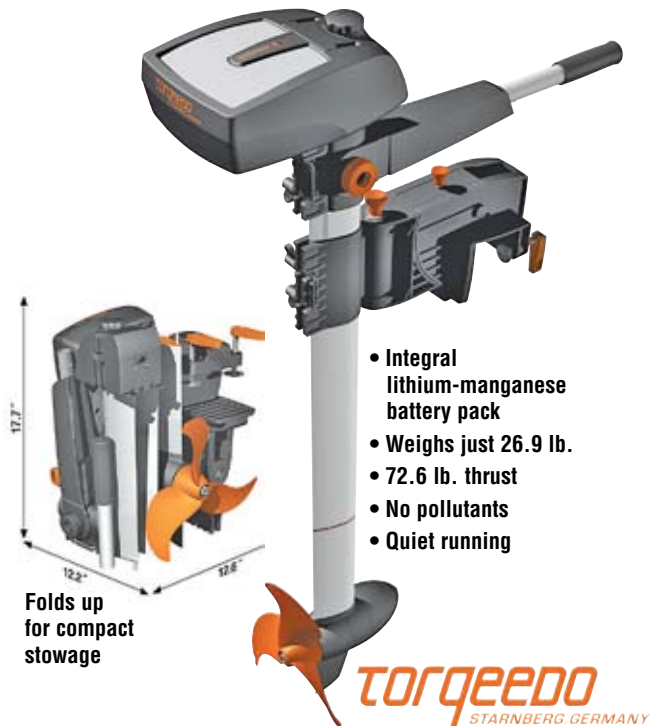

- Integral lithium-manganese battery pack
- Weighs just 26.9 lb.
- 72.6 lb. thrust
- No pollutants
- Quiet running

Folds up for compact stowage

Travel 801 Electric Motor

Finally! A practical alternative to gas-powered outboards that's ideal for tenders, small keelboats and sportboats. The Torqeedo Travel 801 eliminates the mess and potential hazards of gas tanks along with oil changes, tune-ups, fumes and that infernal racket.

The Torqeedo combines an advanced lithium-manganese battery, highly efficient synchronous permanent magnet motor and variable pitch prop to produce thrust equivalent to a 2 hp combustion motor. It weighs a mere 26.9 lb. (with battery) and can be folded for easy stowage and transport.

If you're ready to say good-bye to gas pains, say hello to a better propulsion solution—the Torqeedo Travel 801 Electric Motor.

Long & Short Shaft versions available.

West Marine
We make boating more fun!

Visit our **Alameda Sailing Superstore!**
730 Buena Vista Ave. • 510-521-4865

We have 22 stores in Northern California.
Log onto westmarine.com or call **1-800-BOATING**
to find the store nearest you.

LETTERS

reported stolen to be claimed, and the thieves to be caught. I doubt the thieves would be willing to wait for the money or risk being arrested when it came time to collect. Sure, it



COURTESY TIBURON YC

Tiburon YC lost this antique bell last year to copper thieves.

Tim — We're not familiar enough with the business to know what measures might be both workable and effective, but perhaps requiring sellers to register and document some chain of ownership for the materials they sell might deter some of the thieves.

would be a bit of a hassle for those involved in the business, but far less than the hassle endured by those who get ripped off or suffer the effects. These thieves are causing thousands of dollars of damage to sell stuff for just hundreds of dollars. It's got to stop.

Tim Donnelly
Chewink, Goldengate sloop
Pier 39

Tim — We're not familiar enough with the business to know what measures might be both workable and effective, but perhaps requiring sellers to register and document some chain of ownership for the materials they sell might deter some of the thieves.

↑↓ SAN DIEGO'S POOP IS MORE NUTRITIOUS

I appreciate *Latitude's* Northern California ethos and the inbred Bay Area need to slam Los Angeles whenever possible. So I had to smile when the editor wrote in the June issue, "If we're not mistaken, the City of Los Angeles still pays millions of dollars a year in fines for polluting Santa Monica Bay because it's less expensive than fixing the sewer system."

Well, you are mistaken. A Gannett newspaper study this month, for example, found that L.A. paid a grand total of \$1.6 million in fines over the last five years for sewer spills from its 6,500 miles of sewer lines. Contrast that to the \$3 million in fines assessed against New York City, and the \$6.2 million in fines to San Diego, which has the leakiest sewer system in the west.

Since '98, Los Angeles has met full EPA secondary treatment standards at its Hyperion treatment plant near LAX. All sludge is removed from the 340 million gallons of waste a day before the treated liquid is discharged five miles offshore. L.A. residents have paid extra fees for years to rebuild trunk lines and improve the sewage treatment plant. Sadly, sewage spills do happen, but major upgrades have replaced the oldest section of main lines.

You should also be aware that San Diego is the only city in the country that does not remove sludge from its outfall to the Pacific. San Diego argues that the nutrients — (!) — in their sludge are nothing more than fish food. San Diego has fought hard in Washington for its cherished — read money-saving — federal exemption to the Clean Water Act for 30 years. Yummy.

Hans Laetz
Environmental Reporter
Zuma Beach

Hans — We apologize to everyone for the mistake, and thank you for taking the time to correct us. We'll try to do better in the future.

We're equal opportunity slammers when it comes to pollution. Perhaps you didn't see our earlier reports on the 5.15 million gallons of raw and partially treated sewage that ended up in the Bay as a result of January 26 and January 31 raw sew-



#1 THE SAILBOAT ENGINE IN THE WORLD

COMPACT • LIGHTWEIGHT • RELIABLE • FUEL EFFICIENT



YM SERIES 15-29 HP



JH SERIES 40-125 HP



SAILDRIVES
9-75 HP



5-YEAR LIMITED WARRANTY*

SEE **WHAT'S NEW** AT
A FACTORY AUTHORIZED
YANMAR DEALER
NEAR YOU!



YANMAR FACTORY AUTHORIZED DEALERS:

AQUARIUS BOAT WORKS
Santa Cruz • 831-475-3131

COLLINS MARINE INC.
Bethel Island • 925-684-2758

GOLDEN STATE DIESEL
Oakland • 510-465-1093

J&H MARINE
Stockton • 209-951-0283

KEEFE-KAPLAN MARITIME, INC.
Richmond • 510-235-5564

LIST MARINE INC.
Sausalito • 415-332-5478

MORRO BAY R.V. & MARINE
Morrow Bay • 805-772-5696

NAPA VALLEY MARINA
Napa • 707-252-8011

SAN FRANCISCO BOATWORKS
San Francisco • 415-626-3275

TRINITY DIESEL INC.
Eureka • 707-443-5041

WALKER MARINE
So. Lake Tahoe • 530-541-8514

DISTRIBUTOR:

Boatswain's Locker® • 866-908-2676

931 W. 18th Street, Costa Mesa, CA 92627 • www.boatswainslocker.com



"Marine Power Specialists"
Since 1939

Margaret W Fago Yacht Portraits

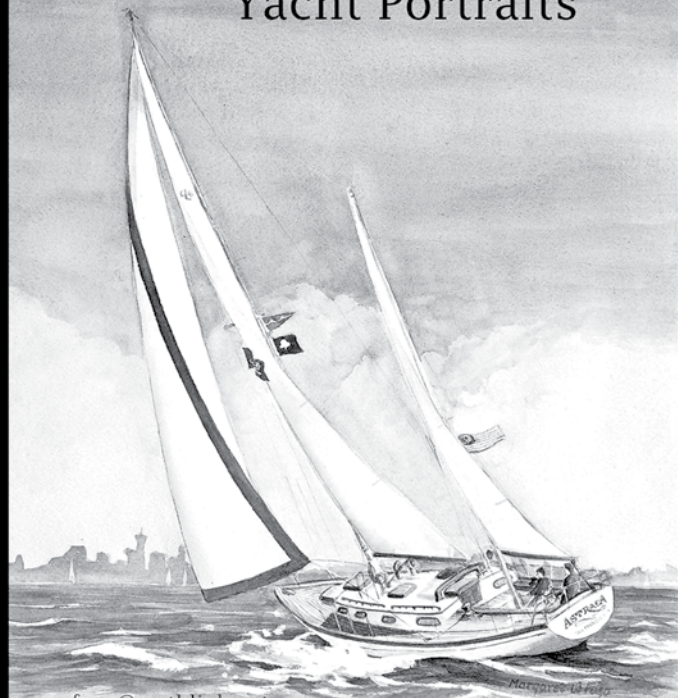

mwfago@earthlink.net
510 522-1309

www.margaretfago.com

FACTORY BLOWOUT SALE!*

**ROCK BOTTOM
SUMMER PRICING**

Exclusive White
LSI 8'8", 9'6", 10'4"

Only from:

**SAL'S
INFLATABLE
SERVICES, INC.**

PHONE (510) 522-1824

FAX (510) 522-1064

1914 Stanford St., Alameda 94501
salsinflatables@sbcglobal.net
www.salsinflatableservices.com

**SUNPROOF
HYPALON
TENDERS**
by Achilles

*Hurry!
Limited to stock on hand

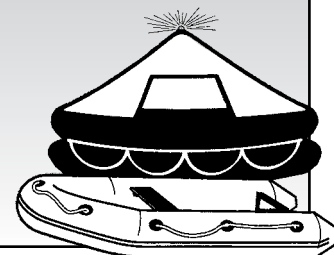

Feeling Stuck?



Gray



White

SPERRY
TOP-SIDER 

Sperry Top-Sider SB1070 Shoes

If your current boat shoes don't exactly give you the reassurance of that "planted" feeling on a wet, heeling deck, maybe it's time to check out the latest in technical footwear from Sperry Top-Sider. Their SB1070 is a prime example of how Sperry's years of experience, combined with the latest in technical innovations and new materials can give you the sure footing you need to be safer, more efficient and more effective on deck in the most demanding conditions. And, along with peace of mind, your dogs will be exceptionally comfortable after a long day on the water, too. Get a more secure "understanding" at your local West Marine today. Try on a pair and feel the difference a great pair of shoes can make.

Model 8647554S 89.99

 **West Marine**
We make boating more fun!

Visit our **Alameda Sailing Superstore!**
730 Buena Vista Ave. • 510-521-4865

We have 22 stores in Northern California.
Log onto westmarine.com or call **1-800-BOATING**
to find the store nearest you.

LETTERS

age spills from a treatment plant here in Mill Valley. Almost a month later, Sleepy Hollow and San Rafael had raw sewage incidents involving 8,000 and 6,000 gallons respectively. But according to state records, Richmond has been the worst in the last 12 months, with 60 spills totalling 2.3 million gallons. Records show that in the last 12 months there have been 276 sewage spills in the Bay Area involving 1,000 gallons or more. So it's not like Northern California poop doesn't stink — or end up in the Bay.

↑↓ MY DAD FIGURED OUT HOW TO SOLVE THEM

When I got back from a vacation in Cancun, the first thing I did was grab a copy of *Latitude* — and was amazed to find that the Lee Helm character in the *Max Ebb* feature was reading a book about partial differential equations. Amazed because my father, John Crank, was instrumental in figuring out how to solve such things. I'd like to know how Max Ebb thought of it being a topic for reading in a Coast Guard class.

By the way, you can Google my dad's name to find his obituary.

Peter Crank
Los Angeles

↑↓ INCENTIVES ARE IMPORTANT

Joel Ross of San Diego wrote in saying he was looking for the boat used in the movie *Captain Ron*. I know where she is. She's owned by At The Helm charters in Kemah, Texas, which is on the Gulf Coast not far from Houston. The outfit can be reached at (281) 334-4101.

James "Boof" Henderson
Bryght Endeavors, Gossard G41
San Pedro Bay

Readers — *Captain Ron*, the '92 flick that starred Kurt Russell, has become a cult film among sailors because of dialogue such as this:

Captain Ron, while they are lost in a big storm: "We should be okay. 'Cause I know we're near land."

Martin Harvey, owner of the boat: "Great, Cap. Great. Ya hear that? We're almost there. Explain to the kids how you know that, *Captain Ron*."

Captain Ron: "All right, now stay with me: When we left, we had just enough fuel to make it to San Juan. And we are out of fuel."

According to Amazon.com, 97 of the 119 people who rated the film gave it five stars. What they really meant was that it was among their "favorite stupid movies."

↑↓ WE NEED YOUR ADVICE ON COMING NORTH

I have a question regarding coastal cruising. I'm delivering a catamaran from Los Angeles to San Francisco Bay, and find that the lesser mass of a catamaran is a disadvantage when powering into headseas. Currently we're at Port San Luis awaiting more favorable conditions to continue on.

You've probably moved *Latitude's* catamaran *Profligate* north along this route many times. What time of year do you find best for the passage? What weather patterns are conducive to southwest or southerly winds between Pt. Conception and San Francisco Bay? Do you hug the coast or go offshore?

Charles & Karin Coleman
Bay Area

Charles and Karin — You didn't mention what size or kind of catamaran you're talking about. Shorter cats can have trouble

Meet the Whitehall twins.



She's all about full-body workouts.

Similar to an open water racing shell, the Whitehall Spirit™ Solo 14 is fitted with a sliding seat, foot stretcher and outriggers. At the catch, your legs and upper back muscles are engaged. By mid-stroke, the remaining major muscle groups in your back, shoulders and arms come into play. And at the end of each stroke (finish), your core muscles are engaged. It's a matter of fact that rowing, as a form of exercise, is more intense than jogging and bicycling, without putting undue strain on your joints.



She just wants to play.

In seconds, the Solo 14 transforms into a sleek picnic boat. Able to accommodate up to four people, there's still room for the picnic basket, cooler and fishing gear. And with two sets of oarlocks, one or two people can row. The hull shape makes her nimble enough to explore the shallows of nearby shorelines. Yet the Solo 14's wide beam makes her more stable than any kayak for open water crossings. Call 1 (800)663-7481 to test-row the Solo 14 in Sausalito, CA.

For information about the entire line of Whitehall Boats for rowing and sailing, visit www.whitehallboats.com. Mention this ad and receive a FREE Whitehall Boats cap.

Whitehall Spirit Solo 14 is a trademark of Whitehall Rowing & Sail. © Whitehall Reproductions Canada Ltd. 2008. All rights reserved.

**REPAIR
REPAIR
REPAIR**

**ROOSTER SAILS
A REPAIR
LOFT**

- CRUISERS' REPAIRS
- FAST TURNAROUND
- RACING REPAIRS

**YOUR ROLLER
FURLER UV COVER
SPECIALIST**

ROOSTER SAILS

451 West Atlantic Ave., Alameda Pt. (Alameda Naval Air Stn.)
(510) 523-1977

www.roostersails.com • rui@roostersails.com

Open M-Th 9-6 • Fri 9-5 • Sat by appt.

Owned and Operated by Rui Luis • Experienced Sail Repair and Fabrication

NOW OFFERING NEW CRUISING SAILS!

SAIL REPAIR SPECIALISTS • COMPETITIVE RATES • RECUTS • CONVERSIONS

All New Cruising Guide!

A Cruiser's Guidebook

SEA OF CORTEZ

Shawn Breeding and Heather Bansmer

WWW.EXPLORINGCORTEZ.COM

BLUE LATITUDE PRESS (360) 421-1934

Cleaner and Greener

PURE OCEANS®



NEW! Pure Oceans Boat Care Products

West Marine is proud to introduce our new Pure Oceans line, a new selection of boat care products that have been specifically formulated to be kinder to the environment while delivering performance that equals less environmentally-friendly formulas. The Pure Oceans line includes soaps, cleaners and surface care products that are inherently less toxic, less environmentally persistent, less bio-accumulative and that degrade to substances with similar desirable characteristics when compared to ingredients in conventional formulations. Be good to your boat, and be good to the environment with West Marine's new Pure Oceans Boat Care Products.

West Marine®
We make boating more fun!®

Visit our **Alameda Sailing Superstore!**
730 Buena Vista Ave. • 510-521-4865

We have 22 stores in Northern California.
Log onto westmarine.com or call **1-800-BOATING**
to find the store nearest you.

LETTERS

with strong headseas because they'll pitch a lot and, if they're heavy, they'll also slam into seas like a monohull. But longer and lighter cats can actually motor into headseas rather well, as their bows lift over the seas instead of bashing into them. But when the seas get big enough, there is simply no alternative to slowing down, and if it's bad enough, really slowing down.

Percentage wise, the best time of year to come north is November through February, as there are often long calm spells between storms. Fall is probably the second best time. Spring and summer are probably the worst, but unfortunately, that's when most folks want their boats brought north.

If you can have a flexible schedule, you can still find windows in the spring and summer. When you do find one, go like hell for as long as the window is open. But no matter what the forecast, you should always assume that you'll get hit by 30 knots of wind or more along the Central California coast, so know where your shelters are. The two worst stretches are usually Pt. Conception and just south of Pt. Sur.

Southerly winds between L.A. and San Francisco? They are very common with storm fronts in the winter. In the summer, you'll only find them when the normal summer weather pattern goes completely wacky. By the way, we just checked www.passageweather.com, and based on their forecast, it looks as if the normal summer weather pattern will be wacko for the next week, and as such, you're in for one of the best and longest spring-summer weather windows we've seen for the Central California coast in years. Good on ya!

↑↓ **PASSAGWEATHER.COM IS A GREAT RESOURCE**

It's us again. Thanks very much for informing us about the www.passageweather.com website. What a great tool that is! Right now I'm coordinating with the owner and another crewmember to leave on Sunday. We'll let you know how accurate that forecast was when we get to Vallejo.

Update: When I first contacted you, we'd interrupted the Gemini 34 cat delivery at Port San Luis because of gale force northwest winds along the coast. On May 24 — the beginning of the window of relative calm was identified by www.passageweather.com — we resumed the delivery and motored nonstop to Vallejo in 43 hours. The conditions were ideal — light southerly winds and a very gentle 4-ft swell from the northwest. I've never experienced a better weather pattern for going north along the coast. The website is an excellent tool and gives a more complete look at future conditions than the NOAA forecasts.

Charles Coleman
Delivery Captain

Charles — We're glad it worked for you. We don't think it ever pays to fight gale force winds, as you do nothing but beat up the boat and the crew. As for www.passageweather.com, we think it's like a lot of similar sites in that they get most of their information from the U.S. government. The difference is that much of the same information is presented differently, with some being more user friendly than others.

In a typical month, we receive a tremendous volume of letters. So if yours hasn't appeared, don't give up hope.

We welcome all letters that are of interest to sailors. Please include your name, your boat's name, hailing port, and, if possible, a way to contact you for clarifications.

By far the best way to send letters is to email them to richard@latitude38.com. You can also mail them to 15 Locust, Mill Valley, CA, 94941, or fax them to (415) 383-5816.



Discover

Brisbane Marina



GREAT LOCATION! Just minutes to Central Bay sailing.
GREAT RATES! \$5.90/foot!
GREAT FACILITIES! All concrete docks.
 Newly constructed bathrooms and laundry rooms.
KAYAK STORAGE! \$25 per month.



From Hwy. 101, take the Sierra Point Parkway exit and follow the signs to the marina.

400 Sierra Point Parkway
 Brisbane, CA 94005
 (650) 583-6975
www.ci.brisbane.ca.us
harbormaster@ci.brisbane.ca.us

CRUISING CATS USA

Your West Coast Dealer for
 LAGOON CATAMARANS



LAGOON 380

All-time best selling cruising cat. As roomy as a 46' monohull – but up to 15 knots!



LAGOON 420

Either twin diesels or "hybrid" system (diesel/electric). Salon helm-station also available.



LAGOON 440

Huge galley and salon. Available with 3 or 4 suites. Serious bluewater cruiser.



LAGOON 500

Exceptional comfort and luxury afloat. Easily sailed by a couple – room for 8 guests.

San Francisco Bay
 Seattle

Call
 Toll Free (877) 937-2287

www.CruisingCatsUSA.com

Buy a Sportboat and Let Spinnaker Sailing Help Pay For It!

That's right! Buy a New Ultimate 20 or Antrim 25, put it into our sailing fleet and we'll send you a check every month, PLUS give you free berthing at South Beach Harbor!



New U20 in stock at our dock now!



©2006 DAVID KENNEDY

CALL US AND WE'LL TELL YOU MORE!

SPINNAKER SAILING SAN FRANCISCO

(415) 543-7333

www.spinnaker-sailing.com

We Won't Hand You a Line



The Right Rope for Every Application—In Stock!

Whether you race or cruise, we've got the right line to make every system on your boat run smoother, stronger and more efficiently. And our rigging experts have the knowledge to match precisely the right line to every need. For the best selection of line, from affordable, all-around polyester braid, to the most advanced high-tech cordage, visit the Rigging Shop at our Alameda store location and find out what the right rope can do to make your sailing smoother, swifter and more fun!

 **West Marine**[®]
We make boating more fun![®]

Visit our **Alameda Sailing Superstore!**
730 Buena Vista Ave. • 510-521-4865

We have 22 stores in Northern California.
Log onto westmarine.com or call **1-800-BOATING**
to find the store nearest you.

LOOSE LIPS

Carl's greatest hit.

Pearson Composites, LLC. (formerly TPI) announced last month that they had delivered the 400th Alerion Express 28 to a broker in Western Long Island Sound. The AE28, whose traditional 'Herreshoff-esque' topside look and modern underbody launched ten thousand dreams and a whole new genre — the 'gentleman's yacht' — was drawn by the late Alameda naval architect Carl Schumacher in the late 1980s. Originally intended as a one-off daysailer for a Connecticut client, the project took on a life of its own after awhile, going into production and spawning clubs, websites and eventually even racing fleets, the first of which was San Francisco's very own Fleet One.

Although Carl's name is still synonymous with fast, pretty modern production boats — notably the Express 27 and 37 — and a number of accomplished custom boats — *Wall Street Duck*, *Heart of Gold*, *Swiftsure II* and *Morpheus*, to name a few — in terms of sheer numbers, the 400 AE28s built over the last 14 years make this his most 'successful' design. According to the builder, even in these shaky economic times the boat continues to amaze: "The Alerion Express 28 is selling more briskly today than at any previous time in its history."

Lost and found.

Forget the *Edmund Fitzgerald*. The real 'holy grail' shipwreck of the Great Lakes has finally been found. The 22-gun *HMS Ontario* sank in Lake Ontario in a Halloween-night storm in 1780 with all 130-some hands. But no one knew quite where. Despite dozens of searches over the years, she remained elusive until last month, when a team finally found and photographed her with an unmanned submersible. At least as spectacular as the find itself is the fact that the 80-ft ship is lying mostly upright on the bottom — and is almost entirely intact. Her two masts are still up and there's even glass left in some of the windows! The "miraculous preservation" is due to the extreme depth (500 feet), extreme cold, and lack of oxygen and light, all of which have combined to literally freeze her in time like a fictional ghost ship ready to rise from the depths and sail again. Expedition leaders Jim Kennard and Dan Scoville say there are no plans to raise, disturb or even return to the wreck, which they consider a war grave. (Not to mention that, technically, she is still the property of the British Admiralty.) Even her exact location is being closely guarded, with the team only allowing that it is located in a deep part of the lake somewhere between Rochester and Niagara, New York. The good news for those of us who love this stuff is that work has already started on a TV documentary which will air later this year. In the meantime, to see photos and even a short video of the ship, log onto www.shipwreckworld.com.

Famous yachts in the news.

- The 62-ft yawl *Manitou*, designed by Sparkman and Stephens and built in Maryland in 1936, is up for sale. A sort of king-size version of Olin Stephens' legendary *Dorada*, *Manitou*, built of mahogany planks over oak frames, was considered one of the finest yachts of her day. Her enduring claim to fame was her third owner, John F. Kennedy, who eschewed the official presidential yacht *Potomac* for this unofficial one, which he reportedly sailed often in Chesapeake Bay and off New England. So fond was he of *Manitou* that he called her the 'floating White House.' *Manitou* has undergone an extensive refit in the last five years and is said to be in like-new condition. She's lying in Deltaville, Virginia. Asking price: \$1,950,000.

- On the other end of the scale, *Joltin' Joe*, a 22-ft Chris Craft once owned by Joe DiMaggio, is currently rotting away in a warehouse in Martinez, birthplace of the Yankee Clipper. The boat was presented to him by Yankee fans in thanks for



Nautical Equipment Package

- 1 pair of championship high quality short finger leather sailing gloves, S-XL.

- 2 stainless steel multitools with file, saw, knife, and LED flashlight, perfect for your needs.

- 1 high quality 5.5" alloy security flashlight, 2AAA batteries not included.



Order direct at www.westek.com/nautical

(800) 526-2673



or email our sales team
sales@westek.com
Satisfaction Guaranteed

All 4 for the low price of
Plus shipping and handling

\$29.99



3.5" multitool



2.5" multitool



5.5" flashlight, 2AAA batteries not included

Great package for your boat, perfect for your nautical needs. MQ1023 Rev.1 20080609

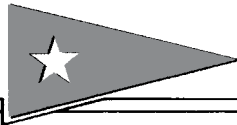

Sausalito Yacht Club

JUNIOR SAILING PROGRAM

Summer 2008

Your Passport to Adventure!



Basic ★ Intermediate ★ Advanced

Sailing courses for boys & girls ages 9-17

Classes throughout the summer Monday-Friday 9-4

For info, call Peggy Plumley

(415) 331-5762 or (415) 332-2336

Headed to the Ha-Ha?

2008 Baja Ha-Ha
San Diego - Cabo
October 27, 2008



Safe Voyages
Begin with Landfall

The **Landfall Premium Personal Safety Kit** features the **Mustang Deluxe Hydrostatic Vest with Harness** and the **Wichard Double ISAF Tether**. The full kit is only **\$399.95** - \$539.89 if purchased separately (use item SPSKOP when ordering).*

Landfall has been providing safety and navigation gear and expert advice for over 25 years. Call us at **800-941-2219** for a free catalog or expert advice. Shop online anytime at www.landfallnav.com.

Landfall
WHERE SAFE VOYAGES BEGIN

SAFETY | NAVIGATION | REFERENCE | WEAR

*Because they contain CO₂ cartridges, all inflatable lifejackets incur special shipping charges for 1-, 2-, or 3-day air delivery. ©2008 Landfall Navigation. All rights reserved.

SHAFT SHARK

**The best rope,
line and debris
cutter there is!**

Two piece unit

For both
power and sail



AB Marine, Inc.

747 Aquidneck Ave.
Middletown, RI 02842

401-847-7960

Fax: 401-849-0631

sales@ab-marine.com

www.ab-marine.com

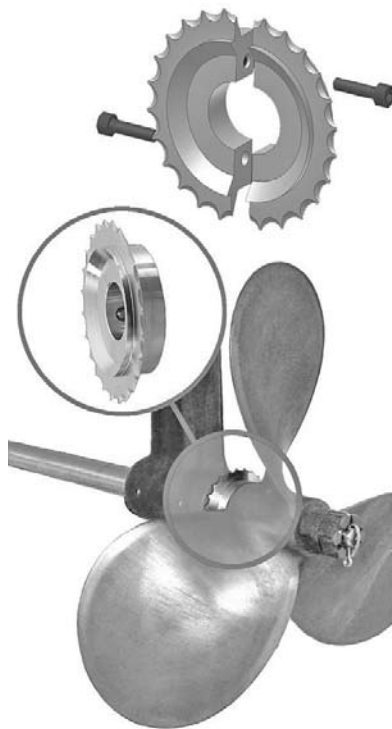

LOOSE LIPS

his 1949 season, in which he hit 39 home runs and had a .320 batting average. It's said that Joe romanced Marilyn Monroe aboard the boat prior to their short year of marriage. But otherwise, he didn't take much interest in boating or in his family's fishing heritage. He eventually gave the boat to a brother, who used it for fishing until both he and the boat got old and tired. The city of Martinez asked if it might be donated and put on display to commemorate their favorite son, and to everyone's surprise, the reclusive Joe himself showed up in 1991 to make it official. The *Joltin' Joe* was buffed back into shape and put on display in 1994, apparently by well-meaning people who didn't know you can't leave a wooden boat out in the open weather very long before bad things happen. They did. In 2006, the boat was pulled off display and is presently stored in a warehouse near the marina, where the decay proceeds at a slightly less rapid pace. According to a *Chronicle* article, no one wants to claim the boat or foot the bill for the extensive repairs it needs — not the yacht club, not the marina, not the local historical society, not the community, not the city and, apparently, not any extended members of the DiMaggio family. (Joe himself passed away in 1999 at age 84.)

Which leaves, perhaps, someone out there reading this. . . ?

Eight bells.

We're sad to report that Roger Jones passed away on June 2 after a short illness. He was 65.

Roger was born in San Mateo, but by the '60s, found himself in Newport Beach, neck deep in the golden age of boatbuilding there. As production manager at Jensen Marine, he oversaw the production of hundreds of Cal and Ranger boats, including the entire run of perhaps the seminal West Coast ocean racer of all time, the Cal 40. In more recent years, Roger was the go-to surveyor for newer buyers of Cal 40s, and was a guiding force behind the large Cal 40 fleets that raced the 2003 and 2005 TransPacs. He was also a go-to resource for *Latitude 38*, and his encyclopedic knowledge of West Coast boatbuilding was reflected in many articles. Roger and wife Lori moved to Reno in 1990 and started the Sierra Nevada Community Sailing, Nevada's first and only non-profit educational community sailing program. He also put much effort into making the environment cleaner and safer for future generations.

Ferry goes down.

In one of the worst maritime disasters so far this century, the 600-ft *Princess of the Stars* sank during a typhoon on Saturday, June 21, apparently soon after she radioed to report she had lost engine power and gone aground around mid-day. Between 700 and 800 people may have lost their lives in the tragedy, which so far has yielded only 32 survivors who managed to get to shore after the ship grounded off Sibuyan Island, about 180 miles from Manila. They told harrowing tales of people slipping on the rain-slicked decks and children screaming as the ship slowly heeled over, eventually capsizing and sinking upside down. Even worse, bad weather prevented any rescue craft from getting to the site for more than 24 hours.

The *Princess* was heading from Manila to Cebu, about 400 miles away, at the time of the accident. Although passenger estimates vary between 600 and 800 people (in addition to a crew of 121), the ship is rated for more than twice that, so she was not overcrowded. But the worst storm for the shipping company Sulpicio Lines may be yet to come: with a typhoon alert in effect, critics say the ship should never have been allowed to leave port. So far the official line has been that, had she not suffered engine troubles, the *Princess* would have been docked safely in Cebu well before Typhoon Fengshen hit.

Gori® propeller



3-Blade



2-Blade



Racing

AB Marine, Inc.
747 Aquidneck Avenue
Middletown, RI 02842

Phone: 401 847 7960

Fax: 401 849 0631

sales@ab-marine.com

www.ab-marine.com



MODERN SAILING SCHOOL & CLUB

Sausalito, CA www.ModernSailing.com 800-995-1668 (415) 331-8250

Get Certified



Call About the Captain's Special

Club Initiation Fee
ASA One Year Membership
Basic Keelboat (ASA 101)
Basic Coastal Cruising (ASA 103)
Bareboat Chartering (ASA 104)

Upcoming Adventure Sailing Trips

Learn from renowned instructor, John Connolly

- ▲ Caribbean / Trinidad - Winter 2008
- ▲ Canary Islands / Spain - Spring 2009

Call for details

Stay Active on the Bay. Join the Club!

ONLY \$35 a Month!

- ▲ July 4th - Club Sail 12 - 6, BBQ & Fireworks 6 - 10pm
- ▲ July 18 - Full Moon Sail
- ▲ July 19 - Full Moon Hike
- ▲ July 30 - Storm Strategies with John Connolly, GGYC @ 7pm
- ▲ Weekly Club Sails!

Call us for details



PREPARE TO TAKE THE HELM



SailDawg.com

Join the Crew

Climb aboard and join in building the most interactive sailing site on the web.

What's Your Sailing Event?

A weekend sail, your cruise, racing - email us the details and we'll post it on the site.

Got Scuttlebutt?

Send us your story, photo or video, and we'll post it on the Dawglog List.

Sailors Want to Know

Comment on and rate your favorite sailing services and products.

Win Prizes

Enter one of our regular contests.

Ready for Some Fun?

Visit us today and check out the latest sailing news, events and more!

SailDawg - Sailing Your Way



BLUESTORM

Prepare for the unexpected



Bluestorm Inflatable PFDs provide the ultimate in style, safety and value.

- Three sailing models with built-in harness
- Manual, fully automatic, or convertible inflation
- USCG approved

Bluestorm
P.O. Box 210
Plymouth, MA USA
(877) 688-5657
www.bluestorm.us

SIGHTINGS

high seas drifter

Once again, a yacht lost months ago has been spotted in mid-ocean on a journey to who-knows-where. You will recall that the Olson 40 *Pterodactyl* had to be abandoned during the March 29 Doublehanded Farallones Race when, about five miles from the islands on the way home, her owner and crew were both washed overboard by a freak wave. Despite being rescued quickly by a nearby yacht, Luc de Faymoreau and Disun Den Daas were unable to reboard the Olson due to the rough sea state. Neither was the Coast Guard after they arrived on scene. The Coasties did manage to toss an EPIRB aboard *Pterodactyl*, which tracked the Olson out to approximately the Farallones before it quit or was itself washed overboard.

Six weeks later, on the night of May 13, the 650-ft Maltese-flagged bulk carrier *MV Namrun* had quite a scare when they almost ran down an unlit sailboat on their way from Xiamen, China, to Houston via the Panama Canal. The encounter happened at position 32N, 136W — approximately 900 miles southwest of the Golden Gate. Captain Melih Akgül and his all-Turkish crew turned the ship around and stood by the sailboat while they reported the incident to Coast Guard Honolulu. At daybreak, they were able to read off the name and homeport: *Pterodactyl*, Moss Landing.

By request of the Coasties, Captain Akgül sent a boarding party over to see if anyone was aboard. Finding no one, they gathered a few personal items, again as requested. Having no way to recover or tow *Pterodactyl*, the 55,000-ton *Namrun* resumed her course for Panama. And *Pterodactyl* resumed hers, making about 1.5 knots southwest.

Upon arrival in Houston, Captain Akgül turned over the personal items from the sailboat (cellphones, laptops and IDs) to the Coast Guard. But they never did tell him the story of what had happened to the boat.

Captain Akgül — a sailor himself with a pretty 31-ft gaff-rigged sloop back home in Marmaris — says he worried about what had become of the crew of *Pterodactyl* the whole rest of the trip after leaving her behind. So while waiting at the airport in Texas for the flight home, he pulled out his laptop and Googled the boat name and hailing port — which popped up 'Lectronic Latitude' reports. He wrote to us straightaway with many of the details you've just read, and the main message: "I was relieved that the crew were saved."

Two weeks later, a Navy ship also encountered *Pterodactyl*, although the person who wrote us did not give a position. As with the *Namrun* encounter, except for the shredded sails, *Pterodactyl* seemed to be in fine shape and had not taken on any water.

The insurance company 'bought' the boat from de Faymoreau in mid-June. He says they have treated him well, for which he's grateful. But though he's technically out of the loop, he follows the reports of *Pterodactyl* sightings with interest. Unfortunately, even if he could have afforded to charter a boat to go after her in the days and weeks following the incident, the chances of her being found, even within days of her last sighting, would be slim. In years past, there have been a handful of similar incidents where boats had to be abandoned outside the Golden Gate. Despite intensive (and expensive) searches by sea and air, none were ever recovered — at least until they came ashore somewhere far away, usually in pieces.

There is a fair chance that *Pterodactyl* might one day be recovered to sail again — assuming she doesn't hit or get hit by anything first.

continued on outside column of next sightings page

see how

Of all the nautical words used to describe all the various boat types and boat stuff, perhaps none evokes the adventure of sailing so much as 'schooner'. These tall, elegant craft — supposedly named for how they 'scooned' (a Scottish word describing how a flat stone skims across the water) — have long been synonymous with distant tropical anchorages, 'bones

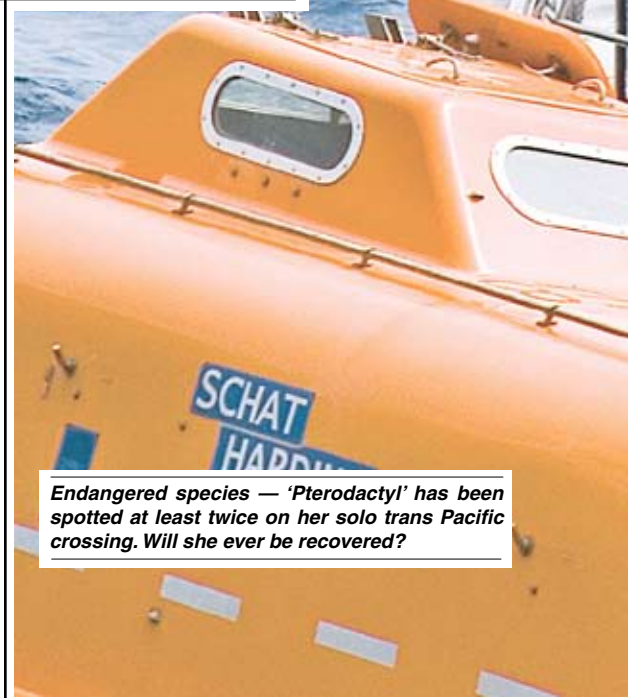

Endangered species — 'Pterodactyl' has been spotted at least twice on her solo trans Pacific crossing. Will she ever be recovered?

they schooner!

in the teeth', swashbuckling personas and all else that is romantic about our sport.

Schooners were once the fastest craft afloat. While their heyday as top racing machines was long ago usurped by more modern (and weatherly) sloops and ketches, there are still a lot of swift, well-sailed schooners around — and folks

continued in middle column of next sightings page

drifter — cont'd

The two precedents that come to mind are the 42-ft *Credimus*, which was abandoned in heavy weather off Cape Mendocino in August, 1997; and the Nauticat 33 *Chaton de Foi*, which was abandoned in Mexico's Papagayo Gulf in December, 2005. Both were found months later, still afloat, off Hawaii. Although both boats showed the ravages of a long drift — lots of guano from roosting seabirds, and *Chaton* had been vandalized — both boats were reclaimed by their owners, and were cleaned, repaired and sailed again.

— jr



PHOTOS MELIH ANKÜL

SIGHTINGS

tragedy at catalina

The 2008 boating season at Catalina got off to a terrible and tragic start on the morning of May 23 when a Eurocopter AS-350 carrying four mariners, plus a pilot and baggage handler, crashed on a sloped field about 75 yards south of the Isthmus YC at Two Harbors. The chartered Island Express helicopter had departed Long Beach a short time before.

The helicopter burst into flames upon impact, almost immediately killing two who couldn't be pulled free of the wreckage. First on the scene was Deborah Hansen, an American Airlines flight attendant and a member of the King Harbor YC. Witnesses described her as "a hero" for helping and encouraging the victims to get free of the wreckage as flames shot to 30 feet in the air. Despite emergency medical attention from others, the pilot died a short time later of an apparent heart

continued on outside column of next sightings page

schooners

aboard them who like going faster than similar craft as much as any other sailor. That's at least part of the impetus behind the newest event on the Bay: The first annual Great San Francisco Schooner Race, which will be held August 23. Created by longtime schoonerman Alan Olson (*Stone Witch, Maramel, Seaward*) and hosted by the San Francisco Yacht Club, this event is open to schooners of all sizes, and there will be divisions for both gaff- and marconi-rigged boats. Judging from the turnout at the Master Mariners in late May — where 14 or 15 schooners were



LATITUDE / JR

— cont'd

in attendance — this has the potential of being quite a spectacle.

Look for a Notice of Race to be posted in the 'regatta' section of *www.sfyf.org* by July 1. In addition to the racing, the tentative plan is to invite vessels to tie up at SFYC from Friday, August 22, through Sunday, August 24. A Saturday night party with music, cocktails and hors d'oeuvres is in the works, with the awards ceremony held on the SFYC deck following the race. For more information, contact *race@sfyc.org*.

— jr

catalina — cont'd

attack. Three passengers survived despite serious to critical injuries. Two are well on the road to recovery from their physical injuries, while one woman remains in very serious condition.

Wayne Noecker, owner of the blue-hulled Alamos Bay-based J/44 *Sabrosa*, asked us to report that two members of his family were involved in the crash. Tania Hurd, with whom he had lived for 16 years, and who was the mother of his 12-year-old son Max, was one of those who perished because she couldn't be pulled from the wreckage in time. A popular culinary arts teacher at John Burroughs High School in Burbank, Tania wasn't the world's most enthusiastic sailor, but she loved playing host to others on *Sabrosa* at a mooring at Two Harbors. We were guests for a number of wonderful brunches she prepared onboard, and knew her to be the antithesis of the Southern California female stereotype.



COURTESY WAYNE NOECKER

Tania Hurd will be missed by many.

Tania was a sweet, soft-spoken and loving woman who will be dearly missed by everyone who knew her. Days after the accident, there were two heavily attended memorial services, one for all of her friends, family, and students, and another at Burroughs High, where several of the students spoke of her as being like a "second mother." In addition, there were large obituaries in the various newspapers, and several unusually long segments on local television stations.

Also aboard the doomed helicopter was C.J. Noecker, Wayne's older son, who turned 30 at the end of May. Because C.J. had suffered a broken back and a compound break of his right leg, he begged not to be moved when help arrived. Rescuers had no choice but to pull him away, as the flames were almost upon him. After a spell in intensive care, his father reports that C.J. is recovering quite well from his physical injuries.

There was a tremendous amount of inaccurate reporting on the accident. The *Chicago Tribune* reported that the crash was caused by driving rain and poor visibility. Untrue, as it wasn't raining and the visibility wasn't bad. Another source said the crash site was near Avalon, which was actually more than 12 miles away. Many sources, including the *L.A. Times*, reported that the helicopter had been on a tour and that the passengers had been picked up from Two Harbors an hour earlier. It was not a tour, and the flight started from the mainland.

The real story is that a powerboat-owning friend of Wayne's chartered the helicopter so that his wife and daughter wouldn't have to make a very early morning trip from the mainland to Two Harbors by boat. With two open seats left on the helicopter, he called Wayne and asked if he knew anyone who would like to use them. Wayne said that Tania and C.J. would be happy to. So while Wayne and Max left Alamos Bay for Two Harbors at 5 a.m. aboard *Sabrosa*, Tania and C.J. boarded the helicopter in Long Beach at about 9:20 a.m. and flew over.

There was no sign of trouble until the helicopter was almost passing over the outer row of moorings at Two Harbors. It was at this point that Doña de Mallorca, in *Profligate's* dinghy, noticed what appeared to be periodic flames coming out of the helicopter's exhaust. Several other witnesses saw the same thing, and one member of the Harbor

continued on outside column of next sightings page

Kickin' it old schoon — 'Brigadoon' and 'Regulus' battle it out in the Master Mariners race. They'll get the chance at a rematch in August at the first annual Great San Francisco Schooner Race.



SIGHTINGS

catalina — cont'd

Patrol even got on the radio to express concern that the helicopter might not be able to land safely. The heliport is on a flat area on the side of a hill about a third of a mile inland from the moorings, and the helicopter was not able to make it.

Exactly what happened after the apparent flame out is not completely clear, as eyewitnesses gave slightly differing accounts, and no official report has been released. Several witnesses said they heard clicking sounds, as if the engine had flamed out and the pilot was trying to restart it. Some of these and others said the pilot appeared to be autorotating the helicopter, which is the procedure used to lessen the impact of a crash. Other eyewitnesses told us that the helicopter appeared to be gliding poorly past the Isthmus YC, at which time the blades suddenly stopped rotating, causing it to fall to the ground like a rock from a relatively low altitude. Whether some low power lines next to the crash site added to the pilot's problems is not clear.

For Wayne Noecker, son Max, and Tania's older son Zachary, the loss of Tania at Catalina is a particularly hard blow, because it happened at a place where the extended family had enjoyed "many of the best times of our lives." Having lost Tania, they worry they might lose the island, too.

— richard

a very long and hard time coming

The catamaran seen sailing in front of the Golden Gate Bridge on June 7 — one of many unusually warm sailing days in June — is Jim Milski's Schionning 48 catamaran *Sea Level*, as captured at the start of the 10-boat Catnip Cup to Vallejo. She was lookin' good.

Originally from Colorado, Milski decided he could best afford the catamaran he wanted by building one himself. We firmly counseled him against the idea, but there was no stopping him, and he purchased a 'kit cat' from Schionning Designs. A contractor, Milski spent several years, along with some other workers, completing the cat in Vallejo. She was launched last December, and the quality of the work is very high.

The inset photo is of Arjan Bok of San Francisco, on the left, sitting next to Milski. After doing the '00 Ha-Ha on his Newport 33 *Tiger Beetle*, Bok, a busy plumbing contractor, also decided to build his own catamaran, a Lidgard 43. Setting up shop in San Francisco, it took him 4.5 years of evenings and weekends to finish the cat, which he eventually christened *RotKat*. The quality of Bok's work was also excellent.

There are two good reasons that both *Sea Level* and *RotKat* are simple boats without a lot of gingerbread. First, because the gingerbread costs a lot more in materials and labor, and second, because gingerbread weighs a lot and slows cats down. Both *Sea Level* and *RotKat* are faster than typical production cats.

One benefit of building your own cat is that you get to know everything about her — and are thus inclined to do things others might fear to try. Bok, for instance, once removed one saildrive — while the boat was in the water! After removing the prop, he unbolted the engine from the saildrive and raised it as high as he could inside the engine compartment. Then he unsealed and removed the saildrive. Sea water poured in, of course, but only to a depth of 16 inches because the cat floats so high and because the engine compartment is so small. Bok says removing the saildrive only took about an hour, about the same amount of time it took to put it back in once it had been repaired. Brilliant!

As for the \$64,000 question, would Milski or Bok build another cat, or recommend anyone else build a cat?

Milski: "No! I would not. I was a contractor for 30 years, so I thought

continued on outside column of next sightings page

the highs and

With cruiser dispatches coming in daily from all over the world, we're constantly reminded of the balance of highs and lows that are characteristic of the cruising lifestyle. A case in point concerns New Zealanders Paul and Gina Rae of the Hylas 44 *Solace*. They bought the boat on the West Coast, cruised Mexico, then did

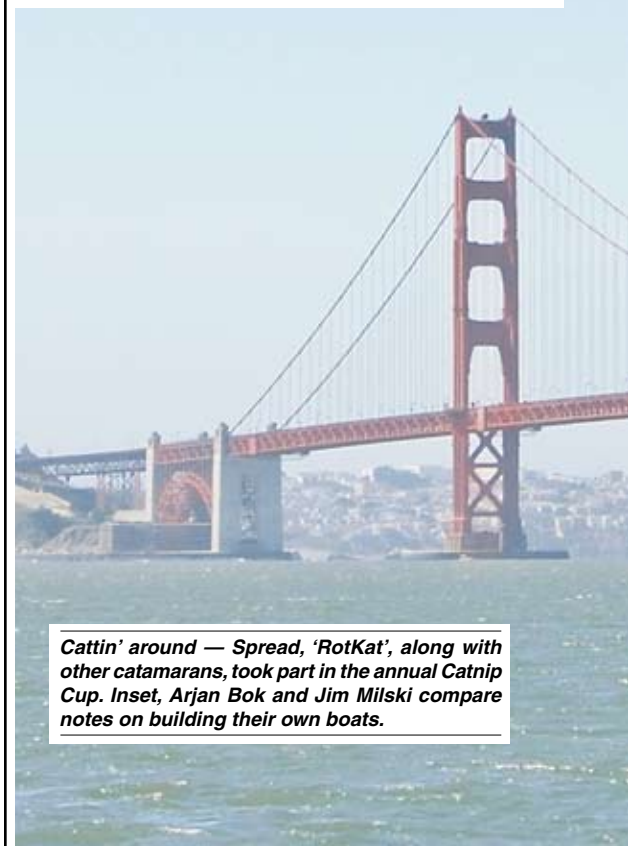

Cattin' around — Spread, 'RotKat', along with other catamarans, took part in the annual Catnip Cup. Inset, Arjan Bok and Jim Milski compare notes on building their own boats.

lows of cruising

the Puddle Jump to French Polynesia this spring.

In late May, they sent a note with the photo in the next spread from the remote French Polynesian atoll of Apataki, in the Tuamotus. "We motored through the lagoon and anchored on the north side

continued in middle column of next sightings page

cats — cont'd

I could handle this, but it's much more difficult than constructing a house — even a custom home. It knocked me to my knees several times. I must have well over 10,000 hours in her and I'm still refining systems!"

Bok: "If I didn't have one, I'd do it again, but since I have one I'd rather be sailing. As for the average person, I don't think most could see the commitment through. For example, sanding alone takes a full year."

— richard



PHOTOS LATITUDE / RICHARD

SIGHTINGS

crap government and courts

In just another chapter in the book on complete crap justice in California, on June 11 Judge Richard Martin ruled there was enough evidence for 39-year-old Bismarck Dinius of Sacramento to stand trial on charges of vehicular manslaughter in the April 29, 2006, boating accident on Clear Lake that resulted in the death of Lynn Thornton.

In a world where there was even a smidgen of justice, Judge Martin would have stopped the four-day hearing during the first 10

continued on outside column of next sightings page

cruising

against a deserted motu. This is where we have spent the last few days in peaceful tranquility. There are enough small reefs around to show us a parade of aquarium fish and sea life."

With that image still fresh in our minds, another note arrived two weeks later with the sad news that Paul had "taken sick" and had to be flown back

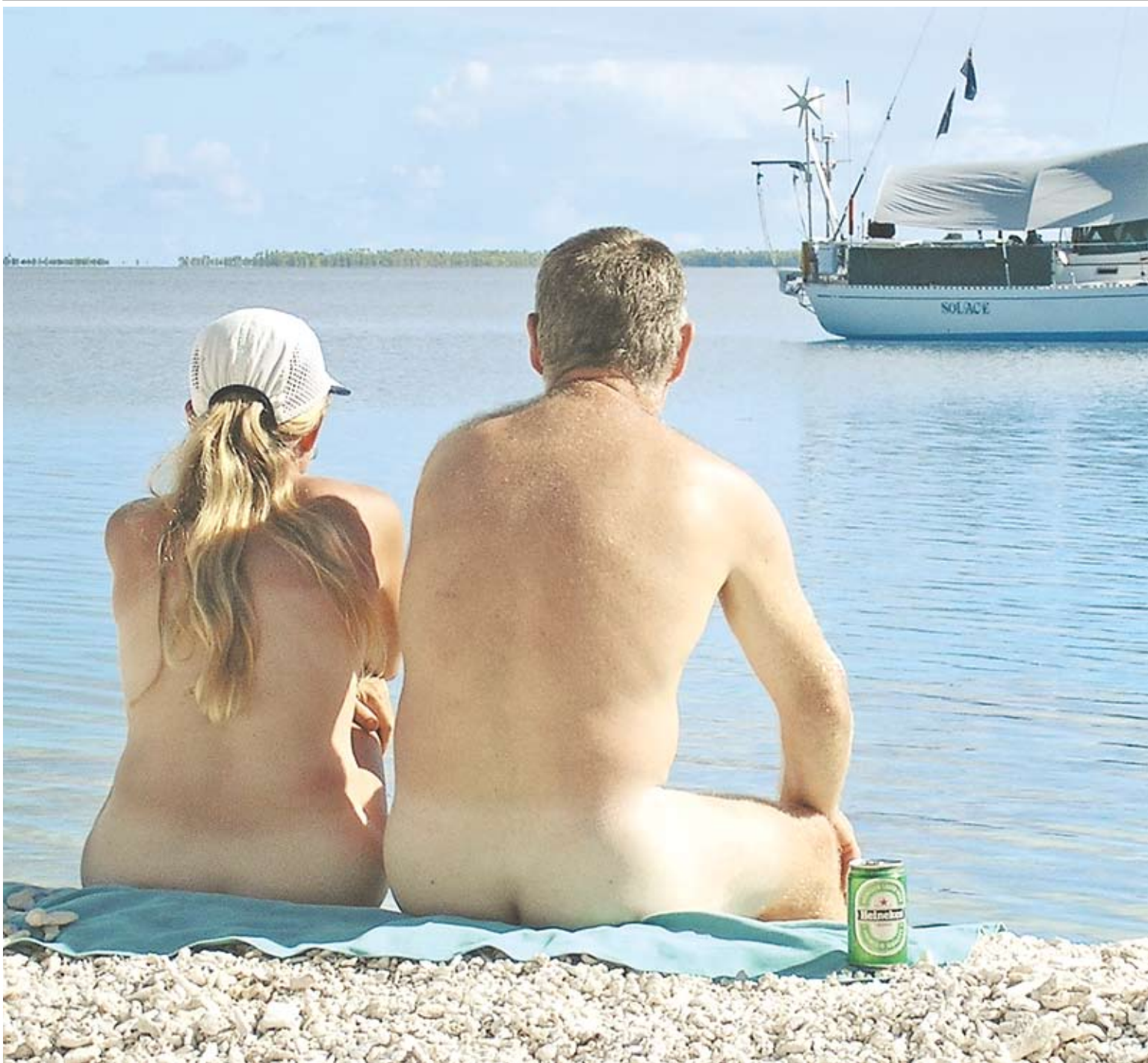

COURTESY SOLACE

— cont'd

to NZ for medical care. Fellow cruisers helped get *Solace* to a Raiatea boatyard where she'll stay on the hard until Paul recovers.

"This has been rather a blow to us," writes Gina, "but like anything else on a boat that breaks down, we will just work on the problem till it is fixed."

— andy



A snapshot in time — This photo exemplifies the cruising life. It's also a reminder to live life to the fullest — shortly after it was taken, Paul Rae fell ill and had to be flown home for medical treatment.

crap courts — cont'd

minutes to excoriate the Lake County District Attorney for charging the wrong man with the crime. As the outrage now stands, Deputy Sheriff Russell Perdock, who on that dark night slammed his high-powered speedboat into the aft quarter of the sailboat that Thornton was on, at an admitted 40 to 45 mph — and perhaps as fast as 60 mph — hasn't been charged with anything!

It would be nice to believe that someone in robes would have recognized that Thornton would not have been injured, let alone killed, had Perdock not been violating the most basic rules of the road. It would be nice to believe that someone in robes would have recognized that Thornton would not have been killed, let alone injured, had Perdock followed even the most basic notion of common sense.

We ask all of you to put yourselves, as ordinary citizens, in Perdock's blood-soaked boat shoes. If you'd been operating your boat at 40 to 45 mph on a pitch black lake at night, knowing full well that there were often boats and rafts on the lake after dark, and slammed into a stationary boat, killing a woman, do you think the District Attorney would have patted you on the back and said, "Don't worry about it, you didn't do anything wrong"? Or do you think he would have kicked your ass in jail and thrown away the key? And if that was the case for you, do you think it was, or should be, any different if the negligent boat operator was a colleague of the D.A.'s in law enforcement?

The prosecution's case rests on two main contentions. First, that the running lights of the sailboat in question, *Beats Workin' II*, were not on. Although the District Attorney apparently didn't want to hear it, at least two witnesses, including a former law enforcement officer, have testified that the sailboat's running lights were on prior to the collision. Second, that Bismarck, who happened to be at the helm, as opposed to the owner of the boat, who was a few feet away, had a blood level of .12, which is over the legal limit. It's true that Bismarck should not have allowed himself to get over the limit — a few years back, mind you, he would have been under it — but what's much more important is that even a stone cold sober Russell Coutts couldn't have driven the near-motionless sailboat out of the path of Perdock's powerboat thundering at them out of the blackness.

Bismarck Dinius is slated to stand trial this fall — unless, against all odds, someone in this entirely corrupt process decides that their vow to stand for truth and justice really means something. That somebody should be former California Governor Jerry Brown, who is currently the Attorney General of the State of California. So what's it going to be Jerry? Are you going to just sit there and collect yet another state paycheck, or do you still really give a damn about justice and the integrity of law enforcement in this state? And please give your answer in a loud and clear voice, because we all want to hear.

If you'd like to donate to Bismarck's defense fund, send checks made out to Bismarck Dinius, writing "Bismarck Dinius Defense Fund" in the memo section, to Sierra Central Credit Union, Attn: Brian Foxworthy, Branch Manager, 306 N. Sunrise Ave., Roseville, CA 95661. You can also email your opinions on this case to the Public Investigations Unit of Mr. Brown's office at piu@doj.ca.gov.

— richard

a race for three generations

The fact that Bay Area sailor Hogan Beatie was tapped to crew for the Los Angeles to Tahiti Race — which should see his ride, Doug Baker's *Magnitude 80*, finish a few days after the July issue of *Latitude 38* is delivered — should come as no surprise to anyone who's sailed with him aboard many of the top big boat programs on the West Coast, including *Magnitude 80*, on which he's been a regular for the last year and a half. But what may come as a surprise to those same people

continued on outside column of next sightings page

generations — cont'd

is that he isn't the first generation in his family to sail the race. He's not even the second. He's the third generation of the Beatie family to sail it.

The first was Beatie's grandfather Mike, who sailed in the inaugural edition back in 1925 aboard the winner, *Mariner*, a 106-ft schooner.



Hogan Beatie

The second was his father Mik, who did the race in 1964 as a young professional-sailor-in-the-making. Given that kind of history, it's no wonder that, while they were proud of Hogan, and thought it was great that the their scion was perpetuating the family's involvement in the race, parents Suzi and Mik didn't exactly throw him a party.

"They're pretty used to it with the big boat sailing I've done," Beatie said who, among other things, has been in the nearly full-time employ of Roy Disney aboard *Pyewacket*.

A couple years in the revival, this year's race — the thirteenth — marks the first running since the late Fred Kirschner's SC 70 *Kathmandu* set the current record for the 3,571 mile race of 14 days, 21 hours in 1994. "We've been planning for it since this

year's PV race," Beatie said. "Doug started talking about it around last year's Transpac. I think he had to wait to see if it was all going to come together. He likes setting records, and that's something the boat can do. There aren't any boats like it on the West Coast anymore."

And set records she has. In 2008, she first stamped her name on the San Diego YC's Vallarta Race, where she lopped six hours off the existing record, and then in Balboa YC's Corona Del Mar to Cabo San Lucas Race, which she finished in a remarkable 2 days, 10 hours 23 minutes. Theoretically, *Mag 80* has the potential to finish off the Pt. Venus Lighthouse near Papeete in a little over 10 days.

In 1925, when *Mariner* won the Tahiti race — which started in San Francisco that year — she did so by 7 days after a 20-day passage. In an article from October 7, 1980, in *Marin Scope*, Jim Wyatt, one of the eldest Beatie's fellow crewmembers aboard the schooner, recounted their arrival in Papeete to writer Annie Sutter, "the crew were treated to a 6 a.m. champagne party by the Governor of Tahiti, after which everybody was entertaining us. Pretty girls took us on picnics to beautiful spots at freshwater pools — they didn't bring anything but mats to sit on, and they gathered breadfruit and bananas and fresh shrimp from the streams. . . ."

"Hopefully, there'll be beverages," the youngest of the Tahiti-bound Beaties said, laughing. And the pretty girls? "My wife is meeting me over there, so I've got that going for me!"

That type of reception is probably behind the mystique and allure of this elusive and irregular race. There are three other entries chasing *Magnitude 80* to Papeete — Jim Morgan's SC 50 *Fortaleza*, Chris Welsh's classic Spencer 65 *Ragtime*, and Bob Lane's Andrews 63 *Medicine Man*. With doldrums shaping up to be about 300 miles wide as of this writing, there will likely be some trying sailing for the boats as they near the equator. "It's going to be a fun equator crossing," Beatie said, and it sounds like King Neptune will have his hands full. "Only two people on the boat have crossed before."

— rob

'tall ship girls' learn life lessons

To casual observers, the launch last month of a hand-built 'Susan' skiff at Aquatic Park probably didn't seem like a big deal. But it was a major milestone in the lives of 12 extremely proud high school girls.

continued on outside column of next sightings page

the ha-ha

Thanks to the fact that folks can now sign up for the Baja Ha-Ha online, as of June 25 there were already 67 paid entries for the 15th running of the event, which begins October 27.

The smallest entry to date is Alan Collier's Emeryville-based Catalina 30 *Solitude*, while the largest is Brian Flander's Sequim, Washington-based Liberty 55 *Rainshadow*. Most of the others are in the 34- to 47-ft band. Four catamarans have signed up, as well as several powerboats. Perhaps most unusual is the number of states already represented: Califor-



It runs in the family — Hogan Beatie's grandfather, Mike (spread) crewed aboard 'Mariner' (inset), the 106-ft schooner that won the inaugural Tahiti Race by seven days.



goes 'lectronic

nia, Arizona, Washington, Mississippi, Maine, Alaska, Oregon and Indiana. Also interesting is that five boats which have recently done the Bash up from Cabo are getting ready to sail south again as part of the Ha-Ha — and more returnees tell us they will be signing up shortly.

For those who have been living on the dark side of the moon, the Ha-Ha is the 750-mile cruiser's rally from San Diego to sunny Cabo San Lucas, with R&R stops at the little village of Turtle Bay and spectacularly beautiful Bahia Santa Maria.

continued in middle column of next sightings page

tall ship girls — cont'd

When the skiff's bow hit the water — to shouts of joy — it symbolized the girls' completion of a life-altering 18-week maritime program called Tall Ship Semester for Girls.

Drawing teenage girls from all over the Bay Area, the accredited course is run by the The Tall Ship Education Academy, a special project of the Recreation & Leisure Studies Department at SF State University. The three-phase program includes six weeks of classroom instruction and small boat sailing lessons, a six-week voyage on a Caribbean-based tall ship, and a six-week boat-building internship at the San Francisco Maritime Historical Park. With normal school disciplines woven into the curriculum, students receive full school credit for their efforts. The course is offered every spring, with full scholarships available based on the needs of applicants. No previous

continued on outside column of next sightings page



PHOTOS COURTESY IAN CHARLES

SIGHTINGS

tall ship girls — cont'd

boating experience is required.

Knowing how to use hand tools and trim sails may prove to be skills these girls will use throughout their lives, but the graduates tell us the 'life lessons' they learned — involving such attributes as teamwork, self-discipline and a strong work ethic — have made an even greater impact on their outlook: "Before all this," said one, "I didn't know what I was going to do with my life. Now I realize the world is full of possibilities."

TSEA will be running a related program this summer called Girls Summer at Sea (June 23 - July 30) which includes three-weeks of voyaging along the California coast aboard the 82-ft schooner *Seaward*. (See www.tallshipacademy.org and www.callofthesea.org for

continued on outside column of next sightings page

ha-ha

The goals of the Ha-Ha are for everyone to have a safe passage to Cabo while making lots of friends along the way. Professional weather forecasts and daily roll calls are two of the services offered to achieve these goals. Are you a party animal looking for a booze cruise to the cape? Sorry, this is not the event for you.

Ha-Ha entries must be 27 feet or longer, and must have been designed, built and maintained for offshore use. There must be a minimum of two crew per boat who have overnight sailing and navigation



— cont'd

experience. While Ha-Ha conditions have generally been pretty benign — winds less than 20 knots from astern — over its 14-year history, all entries must be ready for whatever the Pacific Ocean might dish out. As such, all participants need to be in fairly good physical condition.

The Ha-Ha entry fee is \$350, an amount that is not only a fraction of similar long-distance events, but one that can easily be offset by discounts on products, services and berthing, both in the States

continued in middle column of next sightings page

tall ship girls — cont'd

info about these and other youth programs.)

We should mention also that staffers of the Maritime National Historical Park facilitated sailing instruction for the 'tall ship girls', in addition to guiding their young hands through the construction of their oak-and-mahogany-trimmed skiff. Undoubtedly the ultimate highlight of the day was sailing their smartly painted craft around the Aquatic Park anchorage — in the shadow of the facility's signature vessel, the 300-ft square-rigger *Balclutha*.

— andy

leukemia cup fundraising starts early for local sailor

There is nary a sailor among us who doesn't know the name Gary Jobson. An accomplished sailor, author and TV commentator, Gary has also been a warrior, engaged in daily battle for more than four years with non-Hodgkins lymphoma, first diagnosed in 2003. We are happy to report that modern science and Gary's indomitable spirit defeated the beast — he was declared cancer-free last year. Rather than hide his condition from the public, Gary openly used it to raise money and awareness, mainly for the Leukemia & Lymphoma Society which, among other fundraisers, runs more than 40 Leukemia Cup regattas in venues across the country every year. In 2007, more than 11,000 sailors took part in these events and/or donated some \$3.5 million to help the LLS advance its mission to help fight blood diseases. Gary himself showed up at most of them, handing out awards, shaking hands and posing with winners.

Another accomplished sailor and America's Cup veteran, Tiburon's Ian Charles, has also taken up the cause for the LLS. Given that 75 cents of every dollar raised goes directly toward finding cures, he made fundraising for the 2007 Leukemia Cup a personal mission. With the help and support of many friends and fellow sailors, he was personally able to raise \$30,000. As a result, he was asked to be the chairman for the San Francisco edition of the 2008 Leukemia Cup Regatta, scheduled for October 4-5. His only hesitation was due to the fact that he had no prior personal connection to cancer.

In what has to be the irony of all time, just this past April, Ian was diagnosed with multiple myeloma, an incurable blood cancer.

"Shocked is an understatement to describe what I felt when the doctor gave me that news," says the 40-year-old father of two young boys and founder of Rex & Co, a real estate investment company. His shock was matched by all who know him, if only because he seemed like the least likely candidate for any worse medical condition than exhausting all those around him. Before April, Ian customarily completed six to eight triathalons a year. In a single week, he might run 30+ miles, bike 150-200 miles and swim 10,000 yards.

Now he's in chemotherapy, fighting the disease with drugs that were funded in part by the very organization whose regatta he's chairing this year. A lesser man might pull back, change direction, take a break. Not Ian. Again taking a page from the Jobson playbook, Ian is throwing his still-considerable energies into raising an unprecedented \$100,000 for LLS this year.

"The more funds we raise to develop drugs and test protocols, the closer we can get to extending my life and the lifespans of all people with these diseases — possibly one day even curing them," says Ian. "Drugs developed in part by donations are my first line of defense. They are not only keeping me alive, they are allowing me to continue to work, provide for my family and, for the present, lead a mostly normal lifestyle."

Donations can be made directly to the Ian Charles 2008 Fundraising Campaign for the Leukemia Cup Regatta (www.active.com/do

continued on outside column of next sightings page



You go, girls! These Tall Ship Semester grads proudly display the muscles it took to build such a beautiful skiff.



SIGHTINGS

leukemia cup — cont'd

nate/leukemicupgsf/IanCharles) and/or by enlisting the help and support of others to sail in — and donate to — the Leukemia Cup Regatta on October 4-5. For more information on the event itself, log onto www.leukemicup.org/sf.

— jr

just another relaxing beer can race

Having crewed and cruised aboard wooden boats in the past, we've always had a special appreciation for owners of these vessels, because we know how much extra behind-the-scenes work is necessary to keep them sailing. And we have extra-extra appreciation for the minority of owners who actively race their old wooden craft. They not only put in extra-extra hours of maintenance, they know how to deal with emergency situations that you just don't encounter on fiberglass yachts.

Take Peter English's lovely K-38 *Chorus*. Built in San Diego in 1958 (#39 of 40-some K-38s designed and built by the famed Kettenburg Yard), she's been sailing family and friends around the Bay — and occasionally beyond — for almost 30 years now. The bright-finished hull and familiar 'treble clef' spinnaker are familiar sights on race courses from the Master Mariners to the Great Vallejo Race to the Gulf of the Farallones. She even did the Pacific Cup in 1996.

Peter is also a regular at Sausalito YC's Spring Sunset Series, raced early on Tuesday evenings twice a month through the summer. Which is where we underscore our point. Remember the week of scorching temperatures we had in the first part of last month? Hot, dry weather doesn't really affect fiberglass that much, but on traditionally built wooden boats, it tends to make the planks shrink a tiny bit, which makes them pull away from the caulking in between — which makes them leak. At least until the water gets in there and swells the wood up again.

This shrinking/swelling thing is not really noticeable until, well, the boat starts filling up with water, which is what happened to *Chorus* on June 10. "We'd just rounded Blackaller Buoy when someone noticed there was water over the floorboards," said English — "way over the floorboards, and just a few inches from the cushions."

While lots of water below is a wake-up call no matter what you're sailing, Peter put on a game face "while secretly hoping and praying it was just the topside seams," he says. Indeed, this proved to be the case after the boat had been dewatered by the regular bilge pump, a backup bilge pump "and for good measure bailing like hell with a bucket." By the time they dropped the chute at Knox and started the beat to the finish, the water was gone.

Peter says the boat does this every few years, always after a spate of hot weather and always on the port side, which gets full sun most of the day. "My big fear every time is that something big has sprung," he says. So far, the impeccably-kept boat shows little sign of showing her 50 years in such a rude way.

Despite the unintentional water ballasting, *Chorus* went on to win the spinnaker division.

— jr

kiddin' around

Since we ran the feature on youth sailing in the April issue, we've been hearing about some of the programs that didn't get mentioned. One of those is a work-in-progress at the Bay View Boat Club in San Francisco. Like most things boating, this program began over refreshments at the club. A teacher at Brett Harte Elementary School mentioned how great it would be to take some kids out on boat rides.

continued on outside column of next sightings page

ha-ha

and down in Mexico. Participants also get the usual bountiful swag bag full of Ha-Ha hats, shirts, burgees, *Latitude 38's First-Timer's Guide to Cruising Mexico* and assorted other goodies.

The Ha-Ha is once again owned by the Grand Poobah, who will be using the 63-ft catamaran *Profligate* as the mothership for the 12th year in a row. 'Banjo Andy'



Coming apart at the seams — The recent heat wave loosened *Chorus's* seams, sending owner Peter English for a bucket when on starboard tack.

— cont'd

returns as the Assistant Poobah, with Donna Andre as the Chief of Security. This threesome has a total of 37 Ha-Ha's to their credit.

Why sail to Mexico? Three of the big reasons are that it's warmer than the States in the winter, the cost of living can be much lower, and the cruisers and

continued in middle column of next sightings page

kiddin' — cont'd

A BVBC member said, "Let's go!" And so it was that 25 fifth-graders got a two-hour ride on member boats earlier this spring. For some kids, it was their first boat ride ever.

The second 'kids cruise' happened on May 19. This time it was 16 third-graders from New Traditions School in the City. BVBC member Meg Sandine is a teacher there, and other members pitched in by volunteering their boats, or by going along as crew. The three boats used were Steve Cooper's Rawson 30 *Rainbow*, John Jaundzems' Cal

continued on outside column of next sightings page



LATITUDE / JR

SIGHTINGS

kiddin' — cont'd

29 *Kai Manu* and Bill Ceragioli's Ranger 29 *Beverly J.* Along as crew were Peter McCool, Arnie Gallegos, Larry Smith and Doug Cowan. John Super ran the 17-ft 'crash boat'. Treasure Island Sailing Center donated the lifejackets for the young mariners.

The cruise itself consisted mainly of motoring up to Pier 39 and back, although *Rainbow* actually sailed part of the way.

So how did they like it? "Same as any other group," says Super. "Most probably won't do it again, 10% were deathly afraid and an-

continued on outside column of next sightings page

ha-ha

locals are more relaxed and friendly. Why do the Ha-Ha to get to Mexico? Previous participants say the best reason is all the great new sailing friends they make, but have also cited the fact that it's historically the best time to sail to Mexico, and that it's given them a firm date to set sail.

Based on the last several Ha-Ha's, we'd



SPREAD: LATITUDE / ROB; INSET LEFT: PETER LYONS/IMAGING.COM; INSETS RIGHT: LATITUDE / JOHN A.

— cont'd

estimate that about 175 boats will sign up for the event with around 155 actual starters. If you're interested in the Fabulous Fifteenth Ha-Ha, please visit www.baja-haha.com for all the event details, including instructions on how to enter. The sooner boats sign up, the higher they are on the list for berths in Cabo.

— richard

kiddin' — cont'd

other 10% can't wait to go again." Since Bay View Boat Club does not have a junior program, Super pointed parents of interested kids to the Treasure Island Sailing Center. He likes the symbiosis of that arrangement. "We take them out, see if they're interested, then guide them to someplace with the expertise to really teach them right."

If there are any other programs we missed in our April piece, we'd welcome photos and information.

— jr

summer sailstice fun

The Vallejo Race has long been touted as the largest race on the Bay, and one of the largest inland races in the nation. But in terms of number of participants, it's no longer the biggest boating event. That title was usurped the weekend of June 20-21 when an estimated 400 yachts and 2,000 people took part in Summer Sailstice festivities at Treasure Island.

This is the eighth year for Summer Sailstice — the global celebration of sailing on the weekend closest to the summer solstice — and the third year for Treasure Island to host the main local celebration. All you had to do to take part in the greater Sailstice was just go sailing anywhere in the world that weekend. But many yacht clubs and racing fleets integrated Sailstice into regattas, cruise-ins, raft-ups and so on — in the Bay, across the nation and around the world.

Besides all the sailors, a unique aspect of Sailstice at Treasure Island was how many non-sailors it attracted. With free admission, it was hard to get accurate stats, but organizers we talked to estimated that about a quarter of those who showed up were new to the sport. This is a big increase compared to how many new people attend boat shows. The estimate was corroborated by several brokers who had new yachts open for inspection. They reported a number of folks who admitted it was the first time they had ever been aboard a yacht.

Sailors or not, there was plenty going on to keep people smiling. Shoreside activities included five different musical groups, a boatbuilding competition, a highly entertaining pirate lookalike fellow named Captain Jack Spareribs, a Coast Guard rescue demonstration, and plenty of food and drink (portions of all concessions went to TISC's community outreach programs). On the water, some 80-85 boats crowded into Clipper Cove to drop anchor or raft up. Many YRA fleets used the weekend for 'counter' races in their seasons, and some 125 dinghies — Lasers, Vanguard 15s, Optis and others — held races in (or just adjacent to) the Cove.

Two of the most popular attractions were the boatbuilding competition and free boat rides. The former pitted three teams against each other to build a boat in just 8 hours — using only \$125 worth of materials — then be the first to pilot it around a short course. Only two teams finished within the time limit, with the race prize going to Bay View Boat Club's pretty little rowing dinghy. Berkeley Marine Center's equally pretty little sailboat got the grand prize.

The free boat rides — especially popular with folks new to sailing — were aboard boats donated by sponsors: a Colgate 26 (Club Nautique), J/80 (J/World) and Catalina 34 (Mission Creek Sail Tours.)

Obviously, there was quite a bit more that happened over the weekend — and more individuals and organizations that helped it all happen — than we are able to mention here. (And quite a bit more worldwide. For more on all the fun, log onto www.summersailstice.com.)

"Everybody we saw, sailors or non-sailors, was happy to be there," said Dave Moore of Cruising Yachts, one of several local brokers to have new boats open for inspection. "It was a great day, a relaxed atmosphere and a terrific crowd. I think this event is one of the best things to happen to sailing in a long time."

— jr



Sailing on the Sailstice — Whether you were racing, rafting up, shopping for a new boat or just hanging out aboard with friends, we hope you had as much fun as we did during Summer Sailstice.

blind sailors knocked down

Recovering from the chaos wrought by a mid-ocean knockdown is a challenge for any sailor, but imagine trying to sort things out if you were nearly blind.

Scott Duncan and Pam Habek, both of whom are legally blind, suffered this grim fate in late May while crossing the Coral Sea, a few days after departing Australia. Sailing aboard their Pearson 390, *Starship*, they were bound for New Caledonia. As reported earlier in these pages, the couple left San Francisco in the fall of 2004 with the intention of becoming the first blind sailors to circumnavigate. (Pam has about 10% of normal vision; Scott has about 5%.)



COURTESY STARSHIP

Pam and Scott.

The knockdown occurred roughly 280 miles south of New Caledonia's Koumac Island, when a freak wave crashed into *Starship*. Scott was in the cockpit at the time just about to strap on his PDF as he prepared for a sail change. Pam was below decks. Scott remembers: "The next second I felt the boat drop beneath my feet and start to roll. In the tick of the clock, I knew that I needed to hit the deck, literally, and I dove for the floor and grabbed onto a support pole. On my way down, I glimpsed a huge wave that towered over the boom coming over the boat. The wave came from the opposite direction of the prevailing wave pattern and crashed straight down on *Starship*. I felt the full force of the wave come down on me with a huge crash and continue to roll the boat to nearly 90 degrees. Everything that was in the cockpit was now flying past me. The sensation was like being in a breaking wave when you are body surfing."

The boat's heavily built dodger was shredded, almost everything loose in the cockpit was washed overboard, and the wind generator support structure was mangled. Below decks, water was up to the floorboards, and, as they would later learn, all that green water had damaged various elements of their electrical system including their engine electronics on their brand new diesel engine. Luckily, though, neither Scott nor Pam was injured. They hove to, and eventually got the mess sorted out, then pushed on northward. After discovering that the engine wouldn't start, they gathered their wits and figured out how to jump start it.

"During our voyage we have learned that, in the midst of a crisis, there will always be success and regrets," writes Scott. "We certainly learned the lesson that, anytime we are in the cockpit, we must be clipped in before leaving the cabin below, despite the perception of safety the enclosure provides. We feel that our training (mainly by Club Nautique's Arnstein Mustad) carried us through the aftermath.

"One of the most frequently asked questions by the media prior to departing on the voyage was: 'How will two legally blind people deal with an emergency at sea? Surely you will have problems and then need to be rescued.' In hindsight we think many people in our situation would have considered firing off their EPIRB and calling to be rescued, especially because it took another 12 hours for the seas to calm after the wave strike. As mentioned, nobody responds perfectly to an emergency, but we drew on our training, used our minds, kept our cool, worked our way through the situation and never once did we let our vision limitations become a negative factor. We were simply people determined to overcome adversity despite our limitations, and ultimately this is what our voyage is all about.

"On our departure day I was asked by a reporter if I thought this

continued on outside column of next sightings page

switlik recalls

Switlik Parachute Company, makers of Switlik life rafts, has issued a safety alert and recall on all of their liferafts. It seems that inflation valves on the rafts might fail to "operate properly and discharge the gas from the CO₂ cylinder into the life raft." In other words, your raft may or may not inflate when your boat is sinking out from under you.

The problem has to do with lubricant degrading the piston O-ring, causing it



all life rafts

to stick. According to their press release, the instances of improper inflation are few — and apparently none have happened in real life situations, only at testing stations — but it's not something you want to ignore.

Switlik will replace the faulty valve at no cost to consumers, so go to www.switlik.com to find a service station near you.

— ld

blind sailors — cont'd

voyage was dangerous. I replied that yes, it is. It can be dangerous for anyone, but if it was easy, then it would already have been done. People have a remarkable ability to achieve great things beyond their perceived limitations, and Pam and I are continually amazed and rewarded by what we are capable of achieving through determination."

During our three decades of reporting on all aspects of sailing, we've met a fascinating cast of characters, but Scott Duncan and Pam Habek are two of the most remarkable. We're happy to report that they have safely reached New Caledonia, where *Starship* is undergoing repairs. For more on their quest, see www.blindsailing.com.

— andy



Lazy, hazy days of June — Clockwise from here, the spectacular weather we had last month gave us lots of sun but not much wind, a problem if your outboard conks out. Good thing this club boat carried a paddle; These military boys soaked in some rays behind Angel Island; Like father, like sons.

THE LATITUDE 38 INTERVIEW

Marc & Doreen

In contrast to many well-heeled modern cruisers, Marc and Doreen Gounard have proven that you don't need a fancy boat, all the latest gadgetry and deep pockets to explore the world under sail. Since launching their home-built 33-ft cat, Imani, in 1994, they have done four half-year stints cruising Mexico and a 4.5-year westward circumnavigation, via the canals, with their young kids aboard.

Marc, a Frenchman who was born in the port town of Sete, but also spent a decade in North Africa during his youth, had dreams of sailing the world since his grade school days.

Doreen, who was born and raised in Massachusetts, was not a sailor before she met Marc, but always loved the water. Some of her fondest childhood memories are of boating and swimming on lakes at New England summer camps.

Permanently based at Sausalito's Galilee Harbor marina, where Doreen is the Harbor Manager, the couple has always home-schooled their kids, Maya and Tristan, whether traveling or at home at Galilee. Now 20, daughter Maya is currently thriving at Hampshire College in Amherst, Mass.

We spent a few pleasant hours with Marc and Doreen recently, learning about their travels and their philosophy about the cruising lifestyle. They plan to take off again this fall for a 10-month circuit out to French Polynesia, then north to Hawaii and home again.

Latitude 38: First a little background. We know you've been together a long time. Did you meet here in Sausalito?

Marc: No, we actually met in Washington, DC in 1985, a while after I had delivered a boat from Greece to Florida. We were married about a year later — 21 years ago.

Lat 38: Doreen, we understand that you didn't know much about sailing when you met. Did you have any idea what you were getting into?

Doreen: Well, without knowing anything about sailing, I found myself falling in love with a sailor. Within the first two weeks it was clear that a boat would eventually be part of our story.

Lat 38: So when did you move to California?

Doreen: In April of '87. I was pregnant with our daughter Maya at the time. A week after we arrived we were invited to go out sailing with some new friends. We had never seen so many boats in one place before. Turned out it was Opening Day.

Lat 38: Tell us about building the boat. Who's the designer and where did you build her?

Marc: We started building her in August of '89, just before the earthquake. We rented a flat in West Oakland with a big backyard — it was sort of a compound, really. Living there

"Within the first two weeks it was clear that a boat would eventually be part of our story."

was pretty edgy, you know, dangerous, but we actually had no problems.

Imani's design is called a 10.2 Inspiration, by Australian designer Roger Simpson. She's 33 feet by 19.5, very beamy, which is why we have so much space. She's very well designed. I'm really, really happy with her.

Lat 38: Is she cold-molded?

Marc: The hull is actually strip-planked with red western cedar; sandwiched with 10-oz triaxial cloth on both sides, and cedar in the middle. The rest is marine-grade ply with fiberglass.

Lat 38: Sounds like pretty challenging work. Had you done

this before?

Marc: No, but I had a mentor, a French guy named Marc Ginisty, who'd built six boats in five years. I was also trained in school as a marine engineer, although I never practiced that profession. I got into sailboats instead, and I had wanted to build one for a long time.

We have a classic monohull rig — nothing fancy — an outboard engine, no roller furling and no fridge. So we've kept her very simple. We do have a wind generator and two solar panels, so in the tropics we have more power than we need. We can watch TV, use the radio, nav lights — all that's taken care of by the sun. And if it's cloudy, it's usually windy, so we use the wind generator. We have virtually no 'carbon footprint'!

Lat 38: How long did it take you to build her?

Marc: About 4.5 years to finish the basic shell. We launched her in '94, then moved her to Sausalito to finish her.

Lat 38: And the cost, if you don't mind us asking?

Marc: About \$35,000 all together, including the plans.

Lat 38: So, you built *Imani* specifically to go cruising?

Marc: Absolutely. I've had cruising in mind since I was 9 years old.

Doreen: And that's why we've always home-schooled both kids. We always knew we were going cruising. Maya's first actual classroom experience was at College of Marin, at age 16, after we came back.

Lat 38: What sort of home-schooling regimen did you follow?

Doreen: We've always looked at what is required by the California curriculum, then we get our own materials.

We've been at it for a while, so I have found that if we can make it as much fun as possible — not really trying to create a traditional school environment at home, but have the learning come through everything we're doing — then it's far more doable.

You've got to figure out what your goals are, and help your kids figure out what their goals are. I was primarily the home schooling parent. There's a point where I told the kids, "You've got two choices in this life. You can be smart, or you can be dumb. It's really up to you. I'm not going to ride you like crazy."

That's what's hard about home schooling on a boat. I see parents end up in a very adversarial position which is really hard on them, and it's hard on the kids. And it destroys the

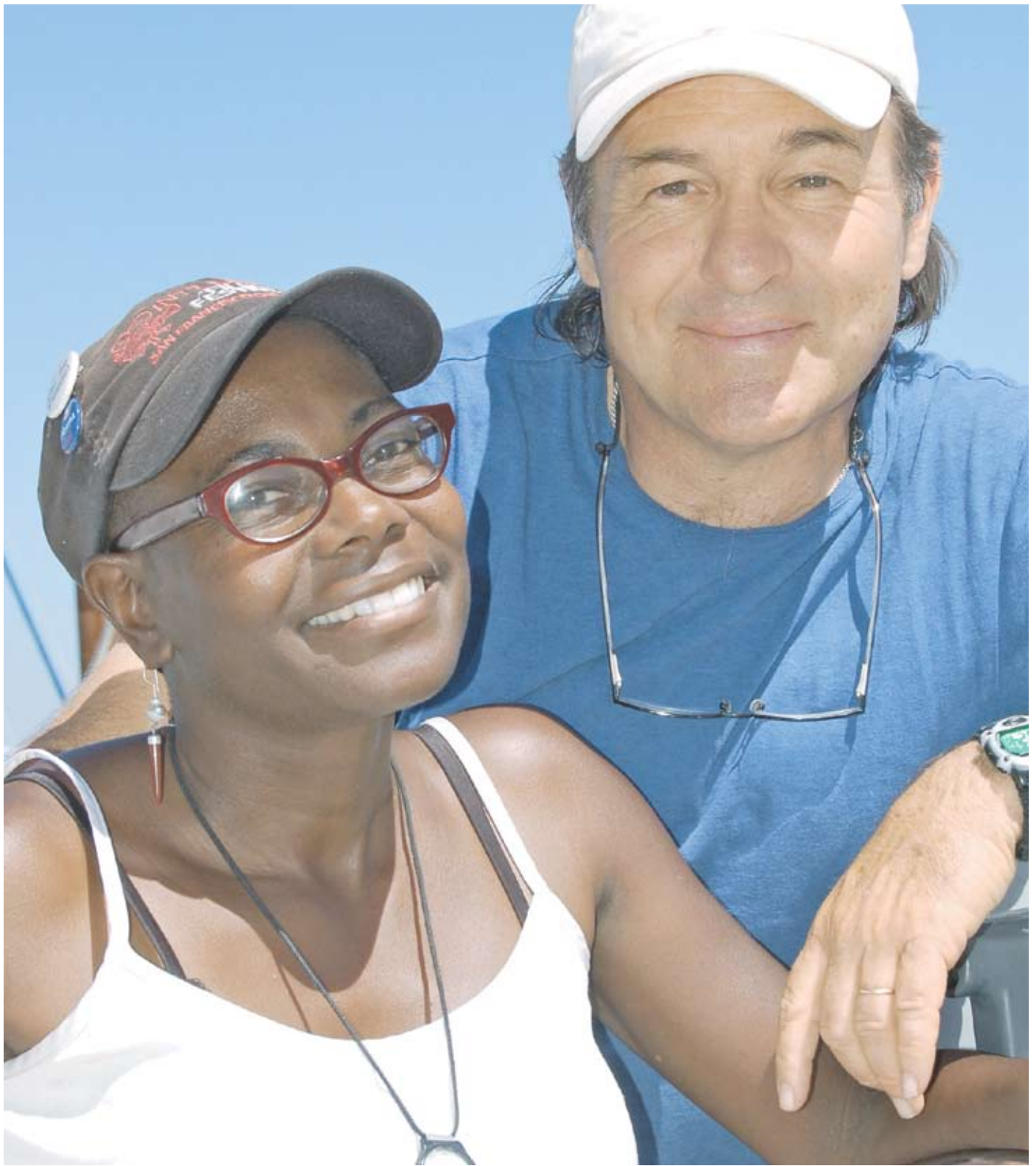

LATITUDE / ANDY

whole cruising thing, 'cause they're trying to make it all about school. Instead, if you can kinda let go of that, and help them understand that this isn't about me, this is about you and your future, things will work out much better. And there's a point when — boom — they get it. They start getting really serious and they organize their time.

Lat 38: We understand you did several Mexico cruises as a warm-up to your circumnavigation.

Marc: Yes, we cruised Mexico for about six months every winter for three years between '96 and '98.

Doreen: Each time, we'd accumulated more gear: a short

wave radio, a better dinghy. . . We were realizing what we needed and what we didn't. It was really good that we had a chance, not only to test ourselves, but to test the boat.

Lat 38: Then in the fall of '99 you finally set off on the big cruise, right? What route did you follow?

Marc: We left on December 11, 1999, from San Francisco directly for the Marquesas. We were blessed, as we arrived on the morning of January 1, at the beginning of the new century! We'd averaged 6.8 knots.

We spent six months cruising French Polynesia — it was easier to get a long-stay visa back then — we went west to the

the latitude interview:

Cooks and Beverage Reef. That was a highlight, incredible! We were going to stay a day, but spent a week. No fishermen go there so the sea life was incredibly prolific. Then on to Samoa and Niue — we swam with whales there!

Lat 38: How old were the kids at that time?

Doreen: Maya was 12 and our son Tristan was 6 — they were only 9 and 3 when we took our first test sail, so they were very accustomed to cruising by then.

Lat 38: Was it always your intention to do a complete circumnavigation?

Doreen: We'd always considered doing it. But by the time we'd spent a few months in French Polynesia we were really getting more solid about the idea. Because of weather patterns,

"They were only 9 and 3 when we took our first test sail, so they were very accustomed to cruising by then."

you're forced to plan ahead. You're always thinking about the next cyclone season and where you're going to end up.

Lat 38: Unlike most Pacific cruisers, you chose not to visit New Zealand and Australia. Why?

Marc: Well, after all that time in America I didn't really want to be with Anglos anymore. I wanted to see something else.

Besides, we knew that New Zealand and Australia were going to be just too expensive for us. So after visiting Tonga, we went north to Tuvalu, Kiribati and the Marshall Islands, where we stayed for three months.

Doreen: Because it's an American territory, it was a great place to collect textbooks and have stuff shipped in. Marc was able to sell a lot of his artwork there too, which helped replenish the cruising kitty.

Marc: From there we headed west to Kosrae — which was fabulous — then to Yap and the Philippines.

Lat 38: Really? We rarely hear of cruisers going there.

Doreen: We hadn't planned to go there until we met this intrepid young couple from Hong Kong sailing aboard a Prout catamaran with two little kids. They'd come back through the Philippines going the opposite direction, and their stories intrigued us.

Marc: It's an amazing place to sail. In fact, I think all of Southeast Asia is one of the best areas in the world to cruise. There's beautiful weather, great people, great food. . . We didn't see any other cruising boats the entire time we were in the Philippines, though. Typical cruisers just don't go there, and I understand why. It's just kind of scary and out of the way.

Clockwise, from upper left: Exploring volcanic outcroppings on Niue, Marc bags a nice one, a treat from the oven, a snorkeling trip on Beverage Reef, the family strikes a pose in the Philippines, an Eritrean camel herder, Tristan combs a lonely beach in Sudan.

ALL PHOTOS COURTESY IMANI

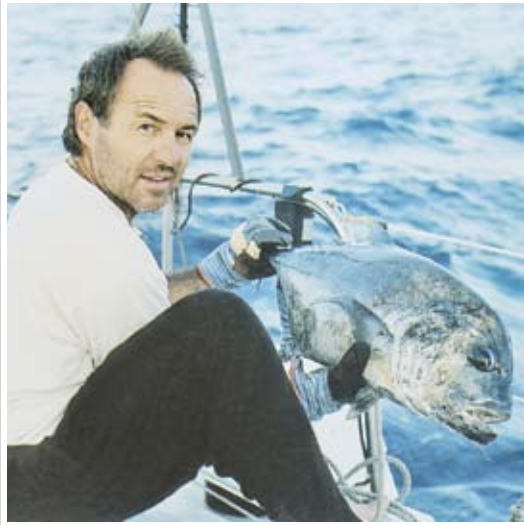

marc & doreen

It's like the Wild West — and really, really poor. You can't imagine how people live. They don't buy a full head of garlic, for example, just two or three cloves at a time. In the stores you see the grandparents and kids breaking down 50-lb bags of flour, sugar and rice into tiny portions, just enough for one day. The toothpaste they sell is the 'sample size'. It's really sad and very corrupt, but the experience with the people was amazing — and many of them speak English.

Doreen: We faced a difficult decision while there. The typhoon season had arrived early and we were trying to get as far south as possible. But when we reached Palawan — in the southwest part of the archipelago — we were really in a quandary about whether to go along the less-protected west side, in the China Sea, or through the more-protected Sulu Sea, on the eastern side, which is notorious for pirates. Some people had just been kidnapped there and had their heads chopped off!

Just as we were picking up the anchor to start heading south, two guys approached in a boat. In front was a guy with a big gun strapped across his chest. They don't have any official uniform or any of that stuff, so we didn't know who we were dealing with. Only Tristan and I were on deck, so I told Marc to stay below for a minute. I found that being a black woman on a boat was really disarming sometimes. It's just not what they expect.

They arrived and the one guy says, "Good Morning," as he

throws his lines to tie up. I asked, "Uhh, who are you?" He says, "We're the Coastal Guard. We just wanted to make sure you guys are okay."

I told them, "Yes, we're fine, we have our exit papers, but we're trying to figure out which way to go." He told us go through

"For three days and two nights we had 50 knots of constant winds, and a reef right behind us!"

the China Sea to avoid the pirates, and that there were enough hidey holes along the outside that we'd be able to find shelter if another typhoon came through.

Marc: Later, we did catch the edge of a typhoon. It was starting to blow just as we were trying to anchor in this little bay. It seemed too deep to anchor, but a guy on shore shouted to us, "Here, here, here!" and directed us over a little ledge. For three days and two nights we had 50 knots of constant winds, and a reef right behind us! That was one of the scariest times, because of that reef.

Doreen: After that, though, we went to Borneo, which was wonderful.

Marc: I used to think of Borneo as a primitive place, but it's not anymore. We were surprised to find that Malay-

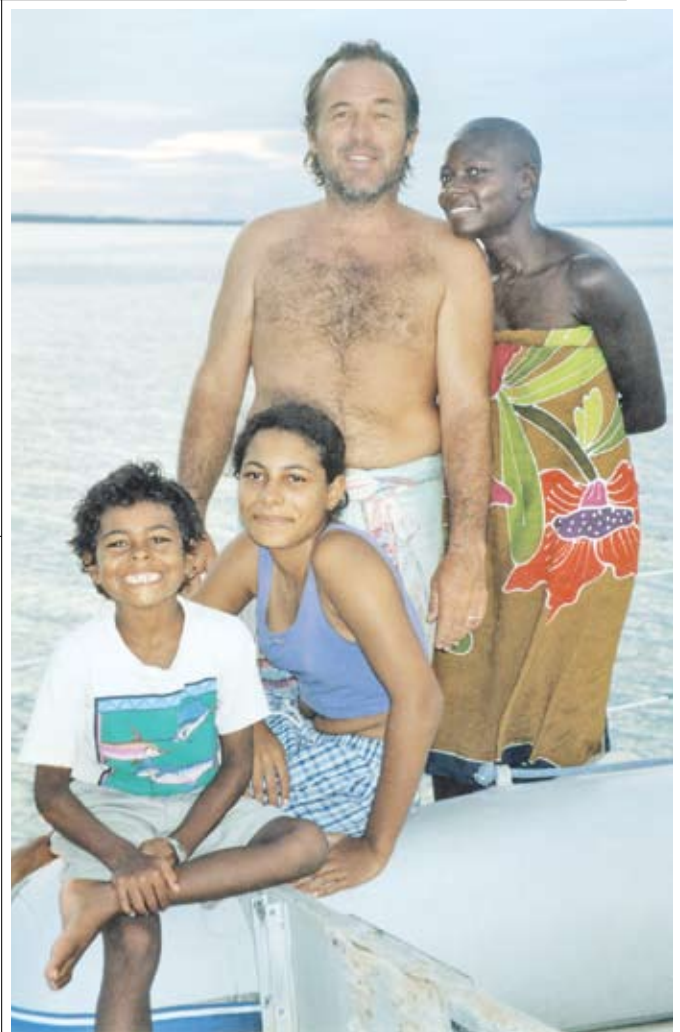

the latitude interview:



Looking very intent, Tristan shows his dinghy driving prowess on a lagoon in the Society Islands.

have some qualifications, they will give you a visa just like that. They're smart! And you can leave your boat there for two years.

Lat 38: Did you pick up any anti-American vibes there?

Doreen: No. They don't seem to be anti-American, or anti-anything. They really appreciated what they call the 'yachties'. It's a kind of tourism they feel they can sustain and support. And they're developing it for themselves too, by training their own kids how to sail through free government programs. We ended up spending 18 months between there and Thailand.

Our daughter, who was 13 then, really loved Malaysia. She felt really free and secure there. She could walk down any street by herself, she said, and men would give her a look of respect. Thailand was the opposite due to the sex tourism and all that. It wasn't the Thais who hit on her, though, but the tourists.

Lat 38: From there, then, you eventually headed west across the Indian Ocean, right?

Marc: Yeah, January is the time to leave Thailand. Years ago I had worked doing charters in the Maldives, so we stopped there on our way to the Red Sea. Unfortunately, as you may have heard, a lot of the coral there is now all bleached out — but there's still plenty of fish.

We arrived in Oman right before the Gulf War, and again had no hassles being Americans.

Lat 38: What about the fact that you are a mixed-race couple? Did that ever draw any weird reactions?

Marc: Well, it's kind of funny, because our kids look like they could be from India, Mexico, Polynesia, the Philippines or anywhere. When we were in Egypt, we presented our passports at the gate to the yacht club and the guy said, "Okay you have two Americans here, but what about those two Egyptian kids?" We laughed and said, "We make Egyptians!"

Doreen: Well, I have to say, I sometimes felt like a Martian! Lots of times people would see this black, bald-headed woman and the look on their face was as if they'd just seen a creature from outer space — I'm just not what they're used to seeing.

Lat 38: What about piracy? Were there any incidents when you were sailing up to the Red Sea?

Doreen: Because of the Gulf War, there were a lot of war ships around. But still, we did have a pirate incident crossing the Gulf of Aden. We were traveling with four Australian

monohulls, when three boats began chasing us — a boat had been hit in the same spot the week before.

There was very light wind, so we started running at full speed with our 9.9hp outboard. I started hiding everything of value, mostly among the kids' toys. I remember hiding my wedding ring in the Legos! We hid the good binoculars and cameras, and

put out the old ones in case they robbed us. We were sweating buckets!

Eventually we were able to outrun them, though. Two of the three couldn't keep up and eventually smoke started pouring out of the third boat. So they gave up and kept going toward Yemen.

"We are a U.S. flag boat, so I called the coalition headquarters on the radio. They said, 'We'll be there in three hours.'"

Marc: We assume they were smugglers who were just traveling along the route from Somalia to Yemen. The real pirates are after the big money. We are a U.S. flag boat, so I called the coalition headquarters on the radio. They said, "We'll be there in three hours."

Lat 38: That's a pretty scary memory. But I bet the Red Sea

The time they spent in Egypt was a highlight for the whole family. Having done her 'homework' on the region's antiquities, Maya took on the role of tour guide.

Lat 38: That's a pretty scary memory. But I bet the Red Sea

The time they spent in Egypt was a highlight for the whole family. Having done her 'homework' on the region's antiquities, Maya took on the role of tour guide.

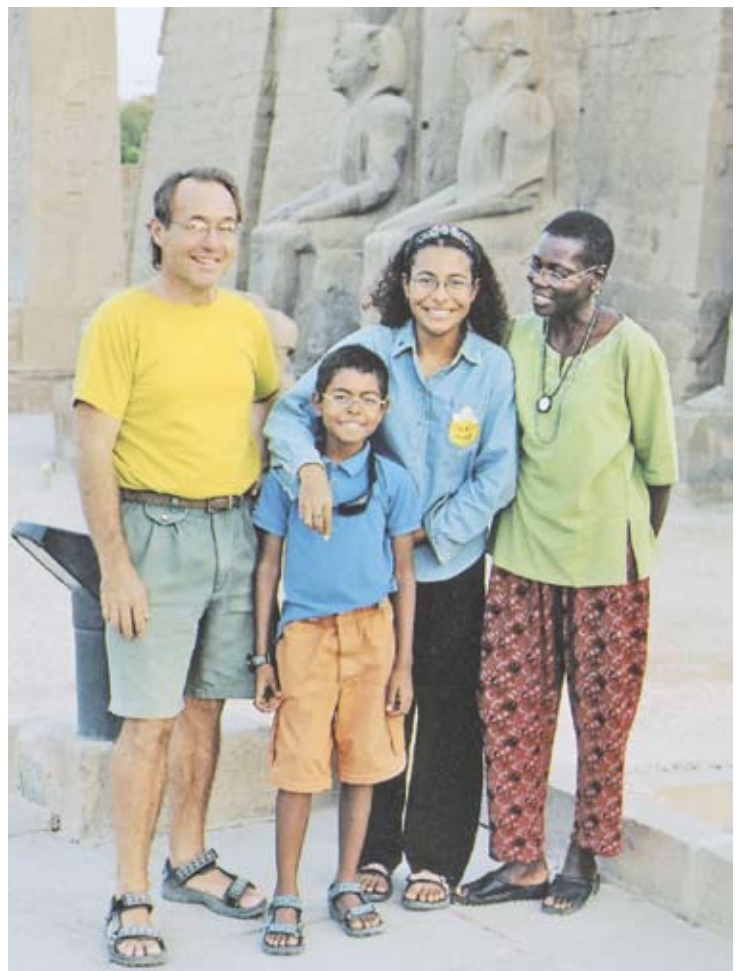

marc & doreen

diving helped make up for it.

Doreen: We all love snorkeling. And the kids were in the water a lot throughout the trip. When we returned here, Maya started volunteering at the Steinhart Aquarium in the tank with penguins, feeding them and giving talks about them.



Being self-motivated is a key to success with live-aboard home-schooling. Here, Maya works on a science experiment.

is less north wind. As the low pressure goes across the Med and over the top of the Red Sea, it sucks away those north winds. And because of the low pressure you get southerlies. If you wait for them, you can catch a nice ride north — that was pretty amazing. But when it's over, it's over. One night we were drifting along at about 3 knots under spinnaker when all of a sudden the wind died. Ten minutes later we had 25 knots on the nose.

Lat 38: Once in the Med, I assume you went to visit family in France?

Marc: Yes, we had a nice time visiting family and friends, but that was the summer of 2003 and it was extremely hot, so there wasn't much wind. In the fall we sailed to the Balearics, then on to Gibraltar, hoping to arrive before it got too nasty. But we saw some very bad weather anyway — amazingly strong wind!

In December we left the Canaries for the Caribbean. In the middle of the crossing we had a week of no wind, so I used the time to work on my artwork, which paid off because I was able to sell a lot of it in St. Barts.

"During the early part of the trip she used to say, 'Your dream is my nightmare and I hate you!'"

Doreen: That was great because we'd spent most of our money stocking up on food, so the kitty was pretty empty. After St. Barts, we sailed up to Georgetown in the Bahamas to rendezvous with Maya's boyfriend and his family, whom we'd met in Thailand. They hadn't seen each other in about a year, so that was lovely. She flew back to California from there to take the high school proficiency exam — they only give it twice a year.

We then sailed down to Jamaica, on to Panama and back to the Bay in June. We were moving pretty fast at that point, because Maya wanted to go to school.

Lat 38: Throughout the trip, how was the balance of enthusiasm between you adults and your kids?

Doreen: When we left, Maya was 12 years old. She didn't want to go, but I told her, "The reality is you're with us, and

Marc: It's such a beautiful world, so rich. Every time you dive you see something new. It's really amazing.

Parts of the Red Sea were fantastic. We took a slow trip sailing across it. During February and March there

you know this is your father's dream." But we worked through it. She was a very reluctant sailor and she just didn't want to do anything. So we made a rule that she had to get off the boat at least once everywhere we stopped.

A lot of places there were no boats with kids, but when we reached Singapore and Thailand there were a lot of boats with kids. That's when she really blossomed. She was able to join the Phuket Riding Club and took horseback riding lessons every day. She really found her tribe among the other cruising kids. We were able to make that time her time.

After that, she had a very different attitude. By the time we got to Egypt she was the one leading us through all the tombs and temples. She had done all the reading, and we all had a blast.

Marc: I think it's important to see that, to see all those works of art, beauty and balance. Everything was painted — tunnels in the tombs — with stories of those ancient people.

When Maya came back she wrote a paper for one of her classes, and had come to the conclusion that the trip was very good for her. She wrote that it had grounded her, so that she knew what she wanted out of life

I felt a lot better when I read that paper. Great, I thought, she doesn't hate me! During the early part of the trip she used to say, "Your dream is my nightmare and I hate you!"

Doreen: Tristan was younger, and he loves sailing. He was much easier. He has a very different temperament. He's content on his own and doesn't need as many friends around to be happy. He's 14 now and a good little sailor.

Lat 38: On average, what do you think you spent per month? I assume you didn't start out with a lot of money.

Doreen: (Laughing) We've never had a lot of money!

Marc: There's no way I'm going to make a lot of money, but we had faith that I could generate some income with my artwork — that's why we named the boat *Imani*, which is 'faith' in Swahili. I have never had a regular paycheck in my life, so I'm used to it. But we have no debt, so, unlike a lot of people, we are free to go.

Doreen: On the circumnavigation, we were probably spending between \$9,000 and \$12,000 a year; between \$600 and \$1,000 a month.

Lat 38: Looking back on the circumnavigation now, would you say the experience met your expectations?

Marc: Yeah, I would say so, Ever since I was young I had read a lot about those singlehanders sailing around the world, and about French families cruising, so I knew pretty much what to expect.

Doreen: Because I had never done anything like this, I didn't have a lot of expectations. I wanted to travel, to experience living in other places, and I loved the idea of being able to step off the boat and become absorbed in a new culture, but then



One useful skill Maya learned was the age-old art of palm tree climbing — without a rope.

the latitude interview:



At home at Galilee Harbor, Marc, Doreen and Tristan are prepping for another cruise. Marc augments his art income by 'coaching' future cruisers to set up their boats sensibly and sustainably.

take a respite from it all by 'coming home' to the boat; to my own little place where I could decompress. It can be overwhelming when you are taking in all the new sights and smells and experiences.

I think that's what cruising on a sailboat is: being able to dip into all these different cultures and meet new people, yet still be able to keep your own identity together.

Lat 38: So what's your advice for would-be cruisers who might like to follow in your wake?

Marc: It's important to understand that you can't

"It's important to understand that you can't control everything. You can't have total security."

control everything. You can't have total security. You have to be ready for the unexpected. For example, the amount of communications equipment some people carry is intense. But still, you might get struck by lightning which fries everything. What are you going to do then?

The other thing is that the cost of traveling like this is really very reasonable once you have the boat paid for. I think a lot of people don't realize that. Also, most people aren't aware of the number of people who are out there living this life — more and more of them from all over the world, from places you wouldn't expect like Poland and Brazil.

Doreen: What I've learned is that for most people there's an aspect of jumping off a cliff. What I mean is, every time you make a passage it's a bit like jumping off a cliff, but you have a parachute because you know your boat, and you know what she can do, so you go with faith. And that's the only way any of us get to follow our dreams — you've gotta jump.

— **latitude/andy**



OWL HARBOR MARINA

THE FRIENDLY MARINA

**HOME OF
ANDREAS COVE YACHT CLUB
Limited Time Only
\$100 Memberships
Call for details**

- 30'-50' deep draft berths @\$5.50 per foot
- Dry and open storage
- Extra wide berths for multihulls
- Home of Club Rio Sailing School

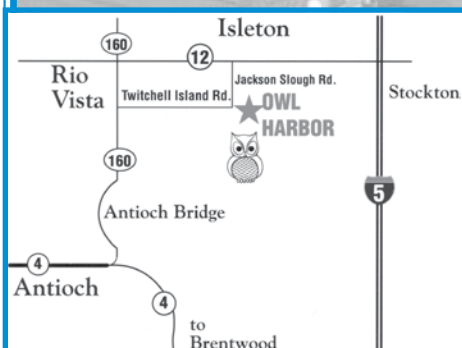

'CANVAS BY THE LOOP' On-site canvas & repair shop

- SAIL - Alterations & Repair
- CANVAS - New & Repairs
- SAILBOAT RIGGING
- HARDWARE INSTALLATIONS
- 12-VOLT REPAIR & INSTALLATION
- FAST TURNAROUND ON REPAIRS

LOCATED ON SEVEN MILE SLOUGH
OFF THE SAN JOAQUIN RIVER

HARBORMASTER: SHAWN PASSERI

(916) 777-6055

email: shawn@owlharbor.com
www.owlharbormarina.com

1550 W. TWICHELL ISLAND RD.
ISLETON, CA 95641

Your Baja Ha-Ha Outfitters!

Sausalito —

295 Harbor Dr (415) 332-0202

Michael Price

Michael has been boating for almost 50 years and has owned a total of 23 vessels (both sail and power), 11 of which he built from the keel up. Before his current 20 year stint with West Marine, Michael was a partner in Anchorage Marine in Sausalito for 10 years. When it comes to maintenance, electrical, plumbing and power, Michael is the "go-to" source for his large following of loyal customers.

Jeff Zarwell

Jeff has been racing on San Francisco Bay for over 25 years and now manages over 90 days of racing each year around the country as a "Certified National Race Officer." Jeff's certification by the United States Sailing Association qualifies him to be the Principal Race Officer of virtually any regatta in the world. In addition to racing, Jeff has also cruised the West Coast and the Caribbean. Jeff has expert knowledge of running rigging for racing and cruising, anchoring, navigation, foul weather gear and electronics.

Alameda — Dan Niessen

730 Buena Vista Av. (510) 521-4865

Dan Niessen comes to West Marine with over 25 years of sailing experience. After competing in the Pac-10 college sailing circuit, he moved up to racing J-Boats, 505s and FDs in the San Francisco Bay Area. Dan currently owns 2 boats and is an avid long distance cruiser and a certified sailing instructor.

Long Beach — Holly Scott

251 Marina Dr. (562) 598-9400

Holly's love of boats and sailing began at the age of nine, when she found a fully rigged Sabot in the living room. By the age of 15 she was skippering her parent's Cal 36 to Catalina and up and down the California coast and bought her very own cruising sailboat at the age of 24. Today Captain Holly has a 100-ton Masters License and charters all over the world. Holly loves to share her knowledge, experience and boating humor.

Newport Beach — Louis Holmes

900 West Coast Highway (949) 645-1711

Louis has been an avid sailor for 22 years. Starting in sabots, he has sailed in regattas ranging from Dinghy and Olympic One Design, to Grand Prix and Offshore events. He has over 6000 miles of delivery experience, including two Mexico returns and a return from Hawaii, and over 10,000 miles of racing experience. Louis is most at home charging down waves or slogging around the next point. Now in his tenth year at West Marine, Louis is eager to tackle your rigging, electronics, and navigational needs to make your boat faster, safer, and easier to sail. Stop into our Newport Beach location to talk to Louis or the many other knowledgeable associates about outfitting your boat for the Baja Ha Ha.

San Diego — Mick Fritzching

1250 Rosecrans (619) 225-8844

Mick has been sailing since he was a small boy. He started out sailing Thistles, Comets, and Lightenings on the finger lakes in upstate New York and built his first sabot out of plywood with his dad when he was 11 years old. Their family yacht was a 60' Alden that his father salvaged off the Jersey shore and completely rebuilt. Mick, along with his wife and son, have cruised on and off for many years, and he is currently restoring a 1967 Columbia Constellation.



Sausalito



Alameda



Long Beach



Newport Beach



San Diego

380 Stores Nationwide
1-800-BOATING
westmarine.com

 **West Marine**[®]
We make boating more fun![®]

FESTIVAL OF SAIL SAN FRANCISCO

The ingenious mind of modern man has created many wondrous things. Among them, towering glass-walled skyscrapers, rocket ships that carry men to the moon and artfully designed bridges that cross mile-wide seaways with a single span. To our way of thinking, though, no man-made creation is more majestic and awe-inspiring than a square-rigged sailing ship bounding along with great clouds of billowing sails straining against a fresh breeze.

If you were cut from the same cloth as

The mere sight of a 'tall ship' will make your heart beat a little faster. . .

we were, the mere sight of a 'tall ship' will make your heart beat a little faster and your face form into a broad smile, while your imagination is transported back to a bygone era when sailing ships ruled the seas as the unchallenged masters of international commerce, exploration and human migration.

This month, you'll have a rare opportunity to get your fill of square-riggers, schooners and a variety of other traditionally rigged sailing vessels as San Francisco hosts the Festival of Sail, July 23-28. The star of this year's fleet will be the U.S. Coast Guard's flagship, *Eagle*, a 295-ft barque that carries more than 21,000 square feet of sail.

We plan to be out on the Bay cheering her on, Wednesday, July 23, as she leads an eye-popping procession of sailing craft along the Cityfront during the Parade of Sail, the inaugural activity of this five-day celebration. We suggest you mark your calendar and join the welcoming party.

The *Eagle* and the rest of the fleet will be available for public tours at dockside Thursday through Sunday, in addition to public sails, mock sea battles and a wide variety of maritime exhibitions. Many participating vessels are actively involved in sail training for youth and/or adults.

Organizing such events has always been a monumental challenge

which requires untold hours of preparation and planning, plus a small army of volunteers. The good news this year is that the nonprofit San Francisco Maritime National Park Association has taken the reins of leadership, and has enlisted substantial support from a broad coalition of corporate sponsors, establishing a foundation that will hopefully be built upon for future events. With the help of ASTA (the American Sail Training Association), tall ship fests are staged along the Left Coast every three years.

This year's ship tours and other festivities will be staged at three waterside 'vil-

lages', each with a specific theme. The Marine Educational Village at Aquatic Park and the Hyde Street Pier will feature a wide range of hands-on learning activities for the whole family including sailboat rides, boatbuilding competitions and historical exhibits.

The International Village will be staged at Justin Herman Plaza and the Ferry Building, showcasing San Francisco's diverse cultural heritage through a variety of international exhibitions.

As the name implies, the Green Village will focus on environmental education, through 200 eco-friendly exhibits and demonstrations.

Adding to the festive mood, each venue will also have live music and other entertainment, plus food and drink concessions. And yes, there will be plenty of on-site restroom facilities.

With that brief introduction, let's have a look at this year's fleet.



America's tall ship, 'Eagle'.

LANCER EKHART

— A TALL SHIP INVASION

(See www.festivalofsail.org for complete event details.)

HMS Bounty — Apart from the *Eagle*, no ship in the fleet has a more colorful history than this finely-crafted replica



'HMS Bounty' will transport you back in time.

of Captain Bligh's notorious vessel. She was built in Nova Scotia, for the classic 1960 version of *Mutiny on the Bounty* — the one starring Marlon Brando as Fletcher Christian. After the filming was completed, she circled the globe to promote the film, and has starred in a variety of productions since, the latest being Disney's *Pirates of the Caribbean II* (2006).

Bounty has the distinction of being one of the largest actively sailed wooden square riggers that is also a full-rigged ship.

Overall Length: 180'; **Beam:** 32'; **Draft:** 13'; **Rig:** Full-rigged ship; **Sail Area:** 10,000 sq. ft.; **Mast Height:** 115'; **Hull:** wood; **Built:** 1960 at Smith & Rhuland Shipyard, Lunenburg, Nova Scotia; **Passengers:** 49 (12 on passages).

Alma — A familiar sight on the Bay, *Alma* is the last remaining example of the hundreds of wooden-hulled scow schooners which brought hay, lumber, produce and other cargo from North Bay and Delta farms to San Francisco's thriving wharves during the 1800s.

Once neglected on a South Bay mud-flat, she was purchased by the state in 1959, and the slow work of restoration began. In 1978 she was transferred to the National Park Service, and was designated a National Historic Landmark in 1988. Today she is one of San Francisco Maritime National Historical Park's most active historic vessels.

Alma sails every season, and is a regular attraction at the annual Master



The privateer 'Lynx' is sleek and fast.

Mariners Regatta every spring.

Overall Length: 62'; **Beam:** 22'6"; **Draft:** 4'; **Rig:** gaff schooner; **Sail Area:** 2,684 ft; **Mast Height:** 76'; **Hull:** wood; **Built:** 1891 in San Francisco; **Homeport:** S.F.'s Hyde St. Pier.

Lynx — This splendid square tops'l schooner is a carefully crafted replica of an American privateer of the same name which was built in 1812. The original was one of the first ships to defend American freedom by evading the British naval fleet which was blockading American ports.

This vessel, however, specializes in doing a variety of youth sailing excursions, as well as corporate teambuilding and sail training.

Overall Length: 78'; **Beam:** 23'; **Draft:** 9'5"; **Rig:** square tops'l schooner; **Sail Area:** 5,000 sq. ft.; **Hull:** wood; **Built:** 2001, Rockport, Maine. **Homeport:** Newport Beach; **Passengers:** 40 on daysails, 6-8 overnight.

Nina — After doing much research, the goal of *Nina's* builders was to produce the first historically accurate replica of a 15th Century Caravel. They chose a Brazilian port town for her construction because they had discovered a group of master shipbuilders

there who were still using design and construction techniques that dated back to the 15th Century. After countless hours of shaping Brazilian hardwoods with adzes, axes, hand saws and chisels, *Nina* was launched in 1991 to begin her career as a globe-trotting maritime history museum.

In her first year, she was featured in Ridley Scott's Columbus epic *1492*, and since then she has visited well over 400 ports. Don't miss your chance to see this



Columbus would be proud on this 'Nina'.

fascinating slice of maritime history.

Overall Length: 68'; **Beam:** 18'; **Draft:** 7'; **Rig:** 1400s caravel; **Sail Area:** 1,900 sq. ft.; **Mast Height:** 54'; **Hull:** wood; **Built:** 1991, Valenca, Brazil. **Homeport:** U.S. & Mexico; **Passengers:** 50 on daysails, 6 on passages.

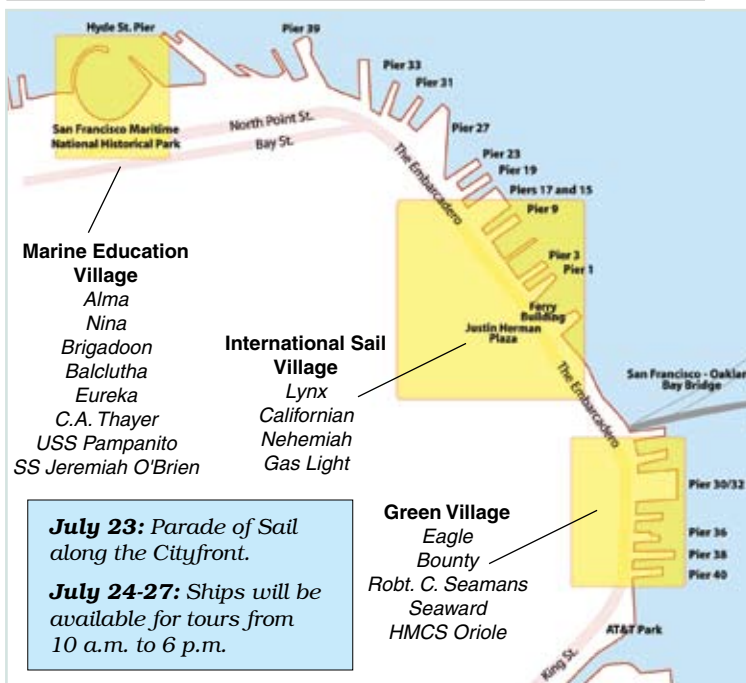

FESTIVAL OF SAIL SAN FRANCISCO



Our state's official tall ship, 'Californian'.

Californian — Built at San Diego's Spanish Landing, and launched in 1984, she is a finely crafted replica of an actual Gold Rush era schooner named *C.W. Lawrence*. The original was commissioned as a Revenue Marine Service Cutter — the Coast Guard's predecessor — and was the first such vessel stationed on the California coast. With that pedigree it's no wonder she was chosen to

be the state's Official Tallship Ambassador.

The *Californian* stays busy throughout the year running programs for both youth and adults that combine basic sail training with the study of coastal ecology and American history.

Overall Length: 145'; **Beam:** 24'6"; **Draft:** 9'5"; **Rig:** Square topsail schooner; **Sail Area:** 7,000 sq. ft.; **Rig Height:** 101'; **Hull:** wood; **Built:** 1983 by Nautical Heritage Society, San Diego. **Homeport:** Long Beach; **Passengers:** 16 (overnight), co-ed, 4th grade through college.

HMCS Oriole (Canada) — This beautiful 102-ft ketch holds the unique distinction of being the oldest commissioned ship in the Canadian Navy — and the only yacht.

But she is not merely a museum piece. In addition to conducting active sail training programs for naval personnel, she is also a regular participant in local and offshore races like the Vic-Maui, the TransPac and the Swiftsure Classic. Based at Esquimalt, near Victoria, BC, she made an 18,000-mile voyage to Nova Scotia and back in 1984 for a tall ship



The Canadian Navy's 'Oriole'.

event.

Fourth in a line of private yachts built for a Toronto businessman, this *Oriole* was completed in 1921 by George Lawley and Sons of Boston.

Still true to her era, she uses no winches. Her spinnaker poles are 42 feet long and weight 125 lbs.

Overall Length: 102'; **Beam:** 19'; **Draft:** 10'; **Rig:** Marconi ketch; **Sail Area:** 15,700 sq. ft.; **Mast Height:** 105'; **Hull:** wood; **Built:** 1921,

AMERICA'S TALL SHIP — BARQUE EAGLE

Dubbed 'America's Tall Ship', the 295-ft barque *Eagle* is the federal government's sole tall ship ambassador to festivals around the world. As such, she has long been a symbol of America's noblest cultural traditions, and the co-ed contingent of U.S. Coast Guard Academy

cadets who serve aboard her always do so with great pride. A stint on the *Eagle*, in fact, is undoubtedly one of the coolest 'duty stations' in all branches of our armed forces. This is one military vessel, by the way, which carries no armament.

Originally named *Horst Wessel*, she is one of five sisterships built in Germany for naval cadet sail training in the '30s. At the end of WWII, she was taken as a prize of war, then was sailed via 'the Columbus route' across the Atlantic to New London, CT — still today her home port — and was commissioned by the Coast Guard in 1946. During that crossing, she rode out a mid-ocean hurricane, then survived another one eight years later while en route to Bermuda.

She took the name *Eagle* from a long line of Coast Guard cutters that preceded her. The first was commissioned in 1792, shortly after the formation of the modern Coast Guard's forerunner, the Revenue Marine Service. When *Eagle's* 21,000 square feet of sail are straining against a stiff breeze, she is undoubtedly one of the most beautiful vessels ever to fly the stars and stripes. She's been known to hit 17 knots.

During *Eagle's* nearly continuous voyages, she serves as a seagoing classroom



for roughly 175 cadets and their instructors from the Coast Guard Academy. If you think upkeep on your boat is costly, consider that *Eagle's* complex sail plan requires five miles of rigging! Over 200 lines must be coordinated during a major ship maneuver.

Built to take the abuses of any ocean, her steel hull is nearly a half inch thick. Atop her steel weather deck is a layer of three-inch-thick teak.

If you are a tall ship buff, you'll be interested to know that all four of *Eagle's* sisterships are still active today — 70 years after they were launched. They are *Mircea* of Romania, *Sagres II* of Portugal, *Gorch Fock* of Germany and *Tovarich* of Russia.

Among her many starring perfor-

— A TALL SHIP INVASION



'Gold Star' has sailed the Bay for decades.

George Lawley & Sons, Boston; **Homeport:** Esquimalt, B.C.; **Passengers:** 18

Gold Star — This sleek schooner has been sailing on San Francisco Bay since 1965, but her history began long before that. George Krenkel of Richmond spent 14 years building her before she was launched in 1960.

Two year's later she was purchased

mances, *Eagle* served as the flagship of the epic 1964 OpSail festival in New York, and did so again at OpSail '76 during the U.S. Bicentennial celebration. In that same tradition, her presence at Festival of Sail should be a point of pride for all Bay Area residents, and we would highly encourage you to check her out in person. We're sure this is one government expenditure you'll be glad your tax dollars are funding.

— *latitude/andy*



Overall Length: 295'; **Beam:** 40'; **Draft:** 17'; **Rig:** three-masted barque; **Sail Area:** 21,000 sq. ft.; **Mast Height:** 147'4"; **Hull:** Steel; **Built:** 1936 by Blohm & Voss, Hamburg, Germany. **Homeport:** New London, CT; **Crew:** 19 officers, 46 crew, 175 cadets and instructors.

by her second owners who fitted her out comfortably for Bay and ocean sailing. Since then, she has logged over 35,000 miles of ocean voyaging, including trips to Mexico and Hawaii, plus five trips to Alaska. She's a regular at the Master Mariner's Races and at Tiburon's Wooden Boat Show

Overall Length: 60'; **Beam:** 14'2"; **Draft:** 7'6"; **Rig:** Marconi schooner with gaff foremast; **Hull:** wood; **Built:** 1960, Richmond; **Homeport:** San Francisco.

Robert C. Seamans — Said to be the most sophisticated oceanographic research/sailing school vessel ever built in the U.S., this steel brigantine was built specifically for the Sea Education Association in Woods Hole, MA, for programs in North America and the Pacific. She was designed by renowned naval architect Laurent Giles, and built in Tacoma, WA.

The ship's amenities include a wet/dry laboratory, a large library, classroom, and computer laboratory, which are used by student researchers on programs in the Northern and Tropical Pacific.

Overall Length: 134'; **Beam:** 24'5"; **Draft:** 12'3"; **Rig:** brigantine; **Sail Area:** 8,554 sq. ft.; **Hull:** steel; **Built:** 2001, Martinac Shipbuilding, Tacoma; **Homeport:** Woods Hole, MA.

Bay Lady — The largest USCG certified schooner on San Francisco Bay, Bay Lady was built in Boothbay, Maine, in 1989. She is patterned after the famous Maine Coastal Schooners that have plied the sailing trade on the Eastern seaboard for hundreds of years.

Overall Length: 90'; **Beam:** 22'; **Draft:** 6'; **Rig:** tops'l schooner; **Sail Area:** 2,460 sq. ft.; **Hull:** steel; **Built:** 1990, Washburn & Doughty, Maine; **Homeport:** Pier 40, S.F.; **Passengers:** 77.

Gas Light — Built in 1991 by master shipwright Billy Martinelli, this vessel is a replica of a scow schooner of the same name which plied the Bay and Delta in the late 1800s.

She is one of the Bay's busiest charter vessels, giving passengers an insightful look into the style and sailing ability of the Bay's distinctive, flat-bottomed cargo vessels.

Overall Length: 72'; **Beam:** 19.5'; **Draft:** 3'4"; **Rig:** scow schooner; **Hull:** steel; **Built:** Sausalito. **Homeport:** Sausalito; **Passengers:** 49.

Seaward — Since her arrival on the Bay several years ago, this 82-ft staysail schooner has done a wide range of char-



The 'Bay Lady' is licensed to carry 77 guests.

ter work and youth sail training, both on the Bay and offshore.

When winter approaches, she heads for the sunny latitudes of Mexico, where she offers a series of programs which combine education in traditional seamanship, study of the marine environment and fun in the sun. *Seaward* is owned and operated by the nonprofit Call of the Sea organization.

Overall Length: 82'; **Beam:** 17'6"; **Draft:** 8'4"; **Rig:** stays'l schooner; **Hull:** steel; **Built:** 1988, St. Augustine, Florida. **Homeport:** Sausalito; **Passengers:** 40 on daysails, 15 for overnights.

Nehemiah — Solidly built and tra-

SAILFEST TIPS & NOTES

(See www.festivalofsail.org for full details)

Costs: Visiting the Villages is **free**, but a fee is charged to tour most vessels (which supports their costly upkeep).

- Ship tours from 10 a.m.-6 p.m., Thu-Sun.
- Touring the *Eagle* is free.

• \$10 for a wristband to see all ships in one Village (5-7 ships) on one day; \$20 for an 'all-Village' wristband.

• 'Timed Tickets' (for a specific time) will be given to wristband holders so they will not have to wait in line. (Brilliant idea!)

- Wristbands may be prepaid online.
- Seniors > 65, \$2 discount; kids < 5 free.

Bay Sailing: Tickets can be purchased online for a ride aboard most vessels during the Parade of Sail, and aboard selected vessels for Mock Battle Sails, Daysails & Evening Sails.

Volunteer Opportunities: Volunteer staff are needed in a variety of positions ranging from ticket sales to helping with kids' programs to ship logistics. Sign up online.

Private Group Events: A variety of other special activities can be arranged involving selected ships, including:

- Exclusive after-hours entertainment and socializing.
- Land receptions that include exclusive access to a tall ship.
- Private catered picnics or parties in VIP areas of Villages.

FESTIVAL OF SAIL SAN FRANCISCO

ditionally rigged, *Nehemiah* is an ideal platform for hands-on training that she offers to Bay Area youth, particularly at-risk youth. In addition, she offers custom charters to the general public.

This classic wooden ketch holds the distinction of being the only S.F. Bay charter vessel that has circled the globe — and she's done it twice.

Overall Length: 57'; **Beam:** 14'3"; **Draft:** 6.5'; **Rig:** ketch; **Hull:** wood; **Built:** 1971, Carpenteria, CA; **Homeport:** Richmond, CA; **Passengers:** 32.

In addition to these vessels, don't miss the stationary watercraft of all types berthed at the Hyde Street Pier (S.F. Maritime Park), such as *Balclutha*. The ultimate symbol of the great Age of Sail, this three-masted, steel-hulled square rigger, which was launched in 1886, carried cargo all over the world — and those voyages took her around Cape Horn a remarkable 17 times!

To our way of thinking, inviting non-sailing friends to join you at the Festival of Sail is an ideal way to introduce them



At the highly theatrical Pirate Academy, the young, and young at heart, will learn "the ways of those mischievous water rogues."

to the magic of sailing. Formerly reluctant 'lubbers may get so psyched up, in fact, that they'll beg you to take them out for a day of bashing around the Central Bay on your own boat.

Kids, too, will love checking out the fleet up close. Surveying the tall rigs and chatting with the crews may inspire

them to sign up for a sail training cruise someday. That's one of the best ways we know of for teens to build character and self-confidence, and gain a sense of purpose.

On the East Coast, tall ship festivals have a long and proud tradition. Organizers are able to recruit impressive numbers of European ships, as they can 'cross the pond' with relative ease due to prevailing winds and currents.

We don't have it so easy here — it's a long uphill slog from Panama and an even harder trip across the North Pacific from Russia or Japan. Huge 'school ships' from those countries have visited the Bay before and they'll do so again in the future if they know they'll receive a warm reception.

So we encourage you to lend your full support to this year's Festival, and hopefully the momentum will continue to build so that the Bay can host an even bigger and better sailfest three years from now.

See you on the docks!

— **latitude/andy**

LOCH LOMOND MARINA

**Completely Rebuilt Marina • Gas & Diesel Fuel Dock
Free Pump Out Station • Modern Launch Ramp
Guest Slips Available • Marine Mechanical Boat Repair
Arena Marine Supply Store • Loch Lomond Market**

110 Loch Lomond Drive, San Rafael, CA 94901

Phone: (415) 454-7228 • Fax: (415) 454-6154

www.lochlomondmarina.com

Harbor Master – Pat Lopez • pat@lochlomondmarina.com





**ESSEX
CREDIT**

NEW - USED - REFINANCE

Boat Loans Made Easy®



Let our 27 years of experience go to work for you!

Linda Carroll

866-377-3948 ext. 7215

www.essexcredit.com

EQUAL CREDIT OPPORTUNITY LENDER

Loan Amounts from \$15,000 Instant Loan Approvals*
Zero Down Program* 90 Days to First Payment*

*(Subject to Loan Program Guidelines and Credit Approval)

Reference Code =MAR931

**SAVE TIME WITH
SYSTEMTHREE**

**QuikFair
FAIRING PUTTY**

Sandable in 3 hours!

Silver-Tip QuikFair - Fairing Putty
Hand sandable in 3 hrs.,
machine sandable in 4 hrs.

Helping you put it all together
Get your Free Epoxy Book today, call: 800-333-5514
www.systemthree.com

McDERMOTT COSTA
insurance brokers - est. 1938

Commercial Operations

- COMMERCIAL POLICIES
Marinas, Yards,
Yacht Clubs,
Brokers,
Shipwrights

Pleasure Yachting

- YACHT & BOAT POLICIES
Offshore, Coastal,
Inland and
Liveaboards

Lic. #OB21939

Bill Fowler
McDERMOTT COSTA INSURANCE
(925) 606-6606 Fax (510) 357-3230
bfowler@mcdermottcosta.com

10 WAYS TO REDUCE

Long before 'go green', 'global warming' and 'carbon footprint' became catchphrases for the environmental movement, cruising sailors had harnessed Mother Nature's gifts to cross oceans, charge batteries and stretch budgets.

As Mr. and Mrs. American work to reduce their carbon footprint — the amount of carbon dioxide released into the atmosphere annually by an individual's actions (mainly energy consumption) — cruising sailors and liveaboards can be proud of the fact that our footprints are exceedingly smaller than those of our landbound friends.

The average American produces 20 metric tons (tonnes) of CO₂ every year while the worldwide average is just 4 tonnes. Using one of the many online carbon footprint 'calculators' (www.carbonfootprint.com), we calculated our own personal footprint as liveaboards: 4.203 tonnes. Not too shabby for being plugged into shorepower and driving to work every day.

Then we calculated the footprint of an imaginary cruising couple who never ran their engine, used solar and wind power to charge their batteries, anchored out all year (thus not using shorepower) and didn't fly home to visit family: 2.310 tonnes. Of course, those types of cruisers are few and far between, so we recalculated with the same solar and wind

"I use my kayak, which I've had since my first 'Wanderlust', more than the outboard and dinghy," said Mike Harker, seen here on his shoreside mode of transportaion.

charging systems but added in about 300 annual engine hours, six months of shorepower use and two roundtrip flights



"These adjustable panels gave us 100 amps a day while we cruised the Sea of Cortez," said Jimmie Zinn of the Pt. Richmond-based Morgan 38 'Dry Martini'. "The shadow of one thin shroud can reduce output by as much as 60%."

from La Paz to SFO: 3.556 tonnes. Still lower than the worldwide average.

Of course, there are many variables in figuring one's carbon footprint — are you vegetarian? How much do you recycle? Do you buy locally grown/organic foods? and so on — but it's clear that cruising sailors, whether they are aware of it or not, are 'greener' than many of those who preach conservation. On top of that, in this age of \$5/gallon diesel, they're saving boatloads of cash.

If you're planning your own cruising adventure in the near future — or even if you're out cruising right now — check out this list of 10 ways you can reduce your footprint:

1) Sail more than you motor. Though folks like Lin and Larry Pardey don't feel this way, many cruisers believe engines are a necessity. If you're one of them, challenge yourself to only fire up the 'iron genny' when you absolutely, positively have to get someplace in a hurry. Part of the fun of cruising is kicking back and letting the wind take you where it will — it may take you a little longer, but you'll be impressed with your fuel savings at the end of the season.

2) Row, sail or kayak ashore instead of using an outboard. Not only will your ride be quieter, but you'll get a little exercise and save on



fossil fuels.

3) Instead of hiring a cab or riding a bus, bring along a couple of folding bikes for getting around while in port. They're not terribly pricey and they break down into relatively small 'footprints' on your budget and boat.

4) Install a windvane. While electronic autopilots are great, they drain batteries. Plus they have the annoying habit of dying in the middle of an ocean crossing. Windvanes can easily steer a boat in most conditions, leaving the autopilot in good shape to handle the rest.

5) Consider more eco-friendly products when buying everything from bottom paint to boat cleaners.



COURTESY MIKE HARKER

JIMMIE ZINN

LATTITUDE / ANDY

YOUR CARBON FOOTPRINT



Treading lightly — 'Destarté', shown above at the start of the '06 Ha-Ha, is all set up to use the gifts of nature. Right, small solar chargers are great for PDAs and iPods.

6) Change out all the lights in your boat — cabin, running, anchor — to LEDs. LED lights draw nearly 90% less electricity than incandescent bulbs, give off less heat and last 30 times longer. As replacement LED bulbs are readily available for the more common types of light fixtures, this is one of the cheaper and easier ways to conserve energy.

7) Invest in a wind generator. Humans have used the wind to help them with their chores for centuries, dating back to as early as 200 B.C. Cruisers use

wind generators to charge their batteries but they often don't put out enough juice to keep an average system topped off unless the wind is really howling.

8) Use solar energy. French physicist Antoine César Becquerel first discovered the photovoltaic effect in 1839, but it took another 100 years before modern solar panels were finally developed. They've been a boon to cruisers, allowing large battery banks to charge up without having to run the engine or generator. The substantial investment in the newer, super-efficient panels is quickly recouped these days by a huge savings in fuel.

But that's not the only way cruisers can use solar energy. Solar chargers for your portable electronic gadgets, for ex-



10 WAYS TO REDUCE

ample, aren't particularly expensive, and mean even less drain on your battery bank. And, unknown to most Americans but not at all uncommon in developing nations where cooking fuel is scarce, solar ovens are efficient, insulated boxes that use the sun's rays to cook food and sterilize water. Ideal for cruising in sunny locales, they keep the heat out of the galley and can turn out perfect 'slow cooked' foods — from stew to cake to fish. Check out www.solarovens.org to see if one would work on your boat.

9) Speaking of cooking, break out that pressure cooker and learn to use it. Pressure cookers typically take a third of the time of standard stovetop cooking, and manufacturers claim a 70% energy savings. The new-style pressure cookers (not Grandma's old Presto jigglers) are quite safe — Kuhn Rikon cookers, for example, have five safety release valves that prevent explosions — and take the



TIM SELL

Kayaking to shore allows you to explore nature in peace while conserving fuel.

work out of cooking.

10) While we're on the topic of food, shop wisely. Choose foods with as little packaging as possible and recycle what you can. Buying locally grown foods not only helps the economy of the community you're visiting, but helps reduce your footprint a little more because less fuel is needed to bring the food to your

table. And though most of us don't change our eating habits significantly when we go cruising, consider adding more raw foods to your diet — vegetables, fruit and the like. Not only are they healthier, but you also conserve cooking fuel.

'Going green' doesn't have to mean switching out your Sperry's for Birkenstocks or eating granola instead of Cap'n Crunch. And you don't have to rip out your freezer, or switch to soy diesel, or rely on kerosene lamps either. With all due respect to Kermit the Frog, when it comes to sailing, it is *very* easy to be green. Reducing your carbon footprint helps the environment, it helps the cruising kitty (and possibly the cruise) last longer — and it helps everyone on the way to a brighter, cleaner future.

— *latitude/ladonna*

AS GREEN AS IT GETS!

A windvane from Scanmar

- Not petroleum dependent
- Uses wind and water power only
- Proven for decades
- Silent
- Emergency Rudder



It will steer you around the world without using a drop of oil – not even for lubrication!

www.selfsteer.com

FACTORY DIRECT

SCANMAR
INTERNATIONAL

432 South 1st St. • Pt. Richmond, CA 94804
Tel: 510 215-2010 • Fax: 510 215-5005
Toll Free: 888 946-3826
email: scanmar@selfsteer.com

Peaceful Southern San Diego Bay

**Slips Available
Various Sites**

HOME OF CHULA VISTA MARINA

552 slips with complete amenities from private dock boxes to pool and jacuzzi to ample free parking.

Come feel the South Bay difference.

Permanent or temporary berths available.

(619) 691-1860

Dockmaster's office open 7 days a week

boatslips@cvmarina.com

www.chulavistamarina.com





YOUR BOAT DESERVES IT!

Fully Insured & Marina Approved

Polishing • Detailing • Maintenance
Bilge Cleaning • Washdown
Carpet and Cushion Cleaning

Serving the Bay Area Since 1986

Call now for a Free Estimate

510 428-2522 or 415 457-6300
www.seashine.net



INCREDIBLE SAVINGS ON FUEL AT MARINA CORAL!
Call for a quote ~ 866•302•0066



- The only fuel dock & best launch ramp in Ensenada
- Concrete docks from 30' to 65' with 110v/220v elect., water, cable TV, phone service and wireless Internet, laundry, marine chandlery.
- Enjoy the amenities of the 147 ocean view suite resort which will make your stay the most enjoyable.

www.hotelcoral.com

Reservations toll free **1-866-302-0066**

E-mail: marina@hotelcoral.com Fax-011526461750058 VHF 71
Carretera Tijuana-Ensenada Km. 103, No 3421 Zona Playitas, Ensenada, B.C. C.P 22860

WHALE POINT MARINE & HARDWARE CO.

**A FAMILY OWNED & OPERATED BUSINESS
FOR THREE GENERATIONS** 
MARINE PARTS & ACCESSORIES, PLUS A COMPLETE HARDWARE STORE

"DISCOUNT PRICES WITHOUT THE ATTITUDE"

NO SALES TAX
EVERY ITEM ONLY ON FRIDAY, JULY 4TH
"HAPPY 4TH OF JULY"

DELUXE BOSUN'S CHAIR

Hard bottom seat. Large SS D rings let you snap in shackle and tie in a safety line.



NOW \$79⁹⁹

SILVER MARINE Inflatables



Length..Width.....Max Floor **NOW**
7'8" ... 4'1" .. 2.7hp .. Roll-up **\$699**
8'2" ... 4'3" 4hp .. Roll-up **\$799**
9'8"5' .. 9.9hp... Wood .. **\$1199**

WALKER 8'-10' Dinghy

Very affordable. Converts from row boat to sailboat to motorboat. Polypropylene hull. Comes with oars. Sail kit optional.



10' Dinghy: **\$995⁰⁰** **8' Special \$699⁰⁰**

HAPPY HOOKER Makes mooring simple!

- STEP 1:** Attach line to eye
- STEP 2:** Push "Happy Hooker" forward to straddle mooring boy eye
- STEP 3:** Pull "Happy Hooker" back

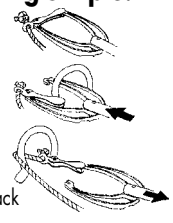

NOW \$29⁹⁹

VECTOR SANDER & POLISHER

1000-3000RPM



NOW \$69⁹⁹

STEARNS Ship'n'Shore Vest

USCG approved life preserver, Type III.

Color: Navy
Sizes: S-XXL



NOW \$59⁹⁹

UNIDEN Solara VHF

All USA, Int'l and Canadian channels. 1 watt/25 watt transmit power. H2O submergable.



NOW \$99⁰⁰

205 Cutting Blvd, Corner of 2nd, Richmond
510-233-1988 • FAX 233-1989
Mon-Sat: 8:30am - 5pm • Sun: 10am - 4pm
Email: whalepoint@acehardware.com

2008 SINGLEHANDED TRANSPAC PREVIEW

In the great pantheon of short-handed ocean races, the Singlehanded TransPac has always flown just below the radar. And chances are, after 30 years, that's not going to change. It will never have the flash of a Transat, the rock stars of a Jacques Vabre or the numbers (or huevos) of a Mini-Transat.

Not only is that okay with organizers and participants, it's how they prefer it.

In the three decades we've been covering the Solo T-Pac (its first start in 1978 coincided with *Latitude 38's* first full year of publication), the race has evolved from precocious youngster to scrappy adolescent to comfortable — if not quite mature — adult. This is an event that's comfortable in its own skin, so to speak, and has its own quiet dignity — but is not above a sly wink and a bit of mischief now and then.

In those early years, the SHTP was a

man-against-the-elements thing. When the naysayers were proven wrong and everyone actually survived the first few runnings, the attraction shifted more to the personal accomplishment end of the spectrum. Those are still big factors. But what really makes this race unique is the camaraderie.

In bigger races like the ones mentioned — or even TransPac and Pacific Cup — sailors on the fast boats are often aboard airliners headed for home before most of the boats even finish.

Those who finish the Solo TransPac tend to stick around. They gather every afternoon in the shade of a big tree on the beach at Hanalei Bay, Kauai, swap stories, laugh a lot and bask deservedly in the glow of mutual accomplishment.

Mark Deppe and 'Alchera' are back this year to defend their overall win in the 2006 Singlehanded TransPac.

That *esprit de corps* alone keeps many of them coming back year after year, and the recidivism rate is correspondingly high — on a typical year, half of the participants are returning veterans. A few of are downright serial offenders.

At this writing, 23 intrepid skippers are signed up to answer the starting gun off Corinthian YC on July 12. Eleven of them are veterans of prior races. Boats in this year's fleet range in size from 20 to 60 feet. Participants range in age from 37 to 78, and in backgrounds from hardworking blue-collar folks to doctors and chemistry PhDs. Two women, both returning veterans, are in the race — as is the 2006 defending champion, the grand master of the Solo TransPac (this will be his 10th race) and one veteran of that very first race in 1978.

Turn the page, and we'll do the introductions . . .



— 30TH YEAR'S A CHARM

SINGLEHANDED TRANSPAC — PAST WINNERS

<i>Year</i>	<i>Starters/Finisher</i>	<i>First to Finish/Skipper</i>	<i>Overall Winner/Skipper</i>
1978	33/22	Solitaire /SC27/Norton Smith	Solitaire /SC27/Norton Smith
1980	38/27	Crusader /Cross 55 trimaran/Mike Kane	Sanderling /Golden Gate/Bob Counts
1982	18/13	Crusader /Cross 55 trimaran/Mike Kane	Pegasus /Wylie 34/Dan Newland
1984	13/11	Tainui /Newick 40 cat/Peter Hogg	Shadowfox /Carlson 29/Mark Rudiger
1986	18/17	Bullfrog Sunblock /Crowther 40 tri/Ian Johnston	Francis Who? /Olson 30/Dan Newland
1988	14/14	Tainui /Newick 40 cat/Peter Hogg	Intense /Olson 30/Bill Stange
1990	19/17	Aotea /Antrim 40 tri/Peter Hogg	Polecat /Freedom 44/Alan Brutger
1992	13/11	Pegasus XIV /Newland 368/Dan Newland	Pegasus XIV /Newland 368/Dan Newland
1994	12/12	Aotea /Antrim 40 tri/Peter Hogg	Illusion /Cal 40/Stan Honey
1996	16/16	Wild Thing /Brewer 60/Ray Thayer*	Rumbleseat ***/30 Square Meter/Bruce Schwab
1998	13/11	Lakota /60ft tri/Steve Fossett**	Giggles /Baltic 36/Dale Parshall
2000	23/22	Sundowner /SC50/Anna Stockel	Starbuck /Black Soo/Greg Nelsen
2002	8/8	Alchera /J/120/Mark Deppe	Haulback /Spencer 35/Jim Kellam
2004	24/21	Dogbark /Open 60/AI Hughes	Sail A Vie /Ericson 35/Phil MacFarlane
2006	16/14	Dogbark /Open 60/AI Hughes	Alchera /J/120/Mark Deppe

* Current monohull record — 10D/22H/53M; ** Current Multihull record holder — 7D/22H/38M

*** Bruce Schwab's *Rumbleseat*, built in 1930, is the oldest boat to race the Solo TransPac.

Course: San Francisco Bay to Hanalei Bay, Kauai; distance 2,120 miles



2008 SINGLEHANDED

Mark Deppe

Alchera — J/120

San Francisco, age 55

Previous SHTPs: 1996, 2002, 2004, 2006

The fourth time was a charm for Mark, whose offshore experience and impeccable preparation finally won him and *Alchera* overall corrected honors in the '06 race.



One of several returning veterans who have sworn several times in the past, "this is my last one — for sure!", Mark seems finally to have accepted that once you do a Solo TransPac, you're hooked. So why fight it?

"There's something very addictive about this race that's hard to explain to the uninitiated. Even though each skipper gives their best effort to do well in the race, no one hesitates to help out and support their fellow competitors as well. We all share the experience of getting our boats ready and passing the qualification inspections. Then we all share the experience of racing to Kauai for two or more weeks. By the time we cross the finish, we are a close-knit family, having shared our best and worst moments, and we have made friends for life."

Christian Humann

Carroll E — Dana 24

Berkeley, age 41

Previous SHTPs: 2006

Chris' first Solo TransPac in 2006 ended with him finishing out of the money, several days after the awards ceremony, and well short of his and his boat's potential. Yet he was greeted like a conquering hero because, in a way, he was (well, maybe not conquering, but a hero). When a fellow small-boat competitor became disabled, Chris turned *Carroll E* around, went and found the guy, and 'escorted' him to the finish. To do this, he had to zigzag to go slow enough (the guy had broken both his main and backup rudders and could only do 2-3 knots steering with drogues), which put him in Hawaii probably two or three days later than he could have gotten there otherwise. In a demonstration of the cool dignity of this event, almost all skippers stayed an extra few days, then motored



out to meet the two boats, greeting them as though they'd just won the America's Cup.

Chris grew up sailing on the West Coast and learned to appreciate short-handling from his father, since it was usually just the two of them. For this year's race, his goals are: not get caught in the Pacific High (or lack thereof); catch a fish again; enjoy the sail again; and the biggie — cross the finish line in time for the awards ceremony.

Robert Crawford

Black Feathers — Cal 20

San Francisco, age 63

Previous SHTPs: 1994

In his second Solo TransPac, Bob Crawford is really pushing the envelope — the small end of the envelope. His Cal



20 *Black Feathers* is both the smallest and oldest boat (hull #14, built in 1961) in this year's fleet. She's also believed to be the first Cal 20 ever to participate in the Solo TransPac, although the minimum 20-ft

length limit has attracted other little boat sailors over the years.

Why so small? "To add to the experience of the Singlehanded TransPac, and to show that big events can still be done effectively with simple boats and modest budgets," says Bob. "It's also a reminder from times past that you really can 'do the race in the boat you have'."

On the more pragmatic front, "I'm sure to be among the last to finish," says Bob. "But I'm hoping my high handicap will keep even the hottest boats a bit on their toes."

James Fair

Chesapeake — Outbound 46

Berkeley, age 61

Previous SHTPs: 1986

Jim grew up in Maryland (thus the name of this new-to-him boat as well as the Merit 25 he's owned for the last two decades), but didn't take his first sail until he was finishing up his chemistry PhD at UC Berkeley in the mid-'80s. That experience (through Cal Sailing Club) gave the Bay one of its most tireless and dedicated racers, and gave Jim a lifetime of enjoyment — which, as it turns out, will accompany him well into retirement.

"As is common with many people who sail, I have the dream of long distance cruising," says Jim, who retired

earlier this spring after 30 years in the

semiconductor industry. "The Merit 25 is not exactly ideal for cruising, so I looked around and settled on the Schumacher-designed Outbound 46. I'm using the Singlehanded TransPac both as a



way to re-experience one of the landmark events of my life, and as a shakedown for the new boat prior to going cruising.

"Once I return, and after fixing everything that breaks, my wife Linda and I will head out the Gate and turn left looking for warm water."

Alan Hebert

Ankle Biter — SC 27

Alameda, age 51

Previous SHTPs: 1996 (unofficial)

Alan has been sailing with SSS off and on since 1994. In 1996, he sailed the SHTP course without entering the race. He was 'official' in 2004, but the roughest first few days in race history broke some stringers loose in his Santana 30/30, so he wisely headed home.

This time he returns to the fray with a more formidable weapon, the SC 27 *Ankle Biter* — a sistership of which held the Solo TransPac record for 10 years.

In a departure from the norm, rather than deal with the expense, time and logistics of getting the boat home, Alan plans to sell it after arrival in Hawaii. Anyone interested in a nicely prepped SC 27 sometime around the end of July can contact him at alansails@yahoo.com.



Al Hughes

Dogbark — Open 60

Seattle, age 55

Previous SHTPs: 2004, 2006

There have been many interesting 'back stories' about the Solo TransPac over the years. Al's is one of the more unique ones. He purchased *Dogbark* in 2004 specifically to do the Singlehanded TransPac, and originally because he felt she could set a new monohull record. But after the '04 event — his first ever race and first time in Hawaii — it was the experience and the people that have kept him coming back for more.

Naturally, a course record would be

pretty cool icing for that cake. And the boat certainly has the waterline and pedigree to do it — as *Jarkan Builders*, it carried Australian Kanga Birtles to a fifth place finish in the '90-91 BOC. In that and subsequent travels, this boat has accumulated more mileage than any handful of his competitors' boats combined. But oddly, in between Solo TransPacs, she doesn't accumulate any. Al puts her up on the hard and 'mothballs' her until the next time. (But he's never far from the water. He repairs boats for a living and lives aboard a 39-ft sailboat that he and wife Lou built 30 years ago.) Even as we write this, he's sweeping out the cobwebs and checking all the systems for his third go at the brass ring. Here's hoping this one's the charm.



John Hayward

Dream Chaser — Valiant 40
Sausalito, age 58
Previous SHTPs: none

Before he did his offshore qualifier for this year's Solo TransPac, John Hayward had never sailed offshore alone before. In fact, up until two years ago, he hadn't done any serious sailing in about three decades. But he's been loving every minute of getting back into the swing of things, and says he is really looking forward to doing the race.

John grew up in Southern California and sailed through his teen and college years. When he moved to the Bay Area, he brought along his trusty Columbia 22. But in a familiar story, he got too busy with life and family to do much sailing. He sold the boat to make part of the downpayment on a house. And that was pretty much it for sailing until he retired from a career as a chemist in 2006.

John's goal is to sail *Dream Chaser* as fast and safely as possible, avoid getting caught in the High, and be content with however he ends up in the standings if he feels he has done his best.

Rob Tryon

Feolena — Valiant 32
San Francisco, age 49
Previous SHTPs: none

Raised in Portland, Oregon, Rob spent many years sailing that "muddy little ditch" called the Columbia River, all the while dreaming of one day sailing in the Singlehanded TransPac. He's put in some serious miles over the years, doing several singlehanded passages up and down the West Coast, a couple of Pacific Cups, and three years of cruising (with wife LaDonna) from the San Francisco Delta to the rugged back country of Southeast Alaska.

While watching the 2006 Solo TransPac fleet sail out the Gate, he decided it was time to finally fulfill his dream.

Because they live aboard their Crealock 37 *Silent Sun* — "and I couldn't take

LaDonna's home away for two months" — Rob bought a bargain Contessa 26 and spent several months working on her.

Then, last winter, a friend offered the use of his new-to-him Valiant 32 for the race. "I shook hands quickly before he could change his mind and put the Contessa up for sale the next week," laughs Rob. He admits *Feolena* isn't going to get there much quicker than the Contessa. "But I'll be a lot more comfortable on the way over."



Joshua Siegel

Sunquest — Westsail 32
Portland, OR, age 49
Previous SHTPs: none

Joshua first got his seaboots wet while at Stanford in 1992. "One of my professors had a photo of a sailboat and it piqued my interest," he recalls. "I talked a couple of other residents into taking sailing lessons at Spinnaker Sailing — and I've never looked back."

A couple of years later, he bought his first boat, a 26-ft Pearson Ariel (also named *Sunquest*) and "sailed the dickens out of it" for the next five years. He wasn't very interested in racing, but did complete the 2000 Doublehanded Farallones — during which he discovered that he liked shorthanded sailing, and he really, *really* liked sailing in the ocean. Even after he moved to Portland, Oregon, and bought the Westsail 32, rechristened *Sunquest*, many of his solo ventures were into the ocean.

Joshua first read about the Solo TransPac a decade ago and has wanted to do the last three. But every time, "some reason came up that I couldn't go," he says. This year, in addition to flying down from Portland nearly every weekend to work on the boat (which he berths at Brisbane Marina), Joshua worked



hard to eliminate the 'can't barriers'. The sudden and unexpected passing of his mother in March was the third element that blended his resolve into a sort of 'Perfect Storm of life'.

"All along, she was my biggest supporter and my biggest fan," he says. "So now I have to go, no matter what — because she'd be disappointed if I didn't."

Ken Roper

Harrier — Finn Flyer 31

North Myrtle Beach, SC, age 78

Previous SHTPs: 1984, 1986, 1992, 1994, 1996, 1998, 2000, 2004, 2006

Baseball had the Babe, golf has the Tiger, and the Singlehanded TransPac has the General, Ken Roper. After



sailing in nine of these races (and at least one unofficial one where he singlehanded over to Kauai just to say hi), Ken has become an icon of the SHTP, symbolizing all that is fun and life-affirming about this

race — and about life in general for that matter. At 78, he remains the ultimate juvenile delinquent.

Ken came by his nickname the old fashioned way: he earned it. A graduate of West Point, he attained the rank of Brigadier General in the Army and served active duty in Germany, Korea and Vietnam where he "flew everything with wings or rotors."

Ken retired in 1977 and, for the last 30 years, has pursued his two passions: scuba diving and sailing. He's dived all over the world, and sailed much of it, too, putting about 100,000 miles under the keels of *Harrier* and his previous boat.

"I became interested in the Singlehanded TransPac Race after sailing into Hanalei Bay from French Polynesia in 1978 and anchoring in the midst of the

2008 SINGLEHANDED

Barbara Euser

Islander — Bristol 34
Norfolk, VA, age 59
Previous SHTPs: 2004

"I had so much fun sailing the Single-handed TransPac in 2004, I want to do it again," says Barbara. "During that race, I kept a detailed list of all the improvements I would make to *Islander* for the next SHTP." As all boat owners know, those lists often take longer to complete than planned. She didn't quite make it for '06, and truth be told, she's still got a few projects to go. "But at least the most important ones are done!" she says.

Barbara grew up sailing on reservoirs in Colorado, transferring to Chesapeake Bay after a career move took her and her family (husband Dean and two daughters) to Washington, D.C. They bought *Islander* in 1992, and when they were again transferred, this time to Paris, Barbara and Dean doublehanded the boat across the Atlantic — thence around the Med, French canals and back across the pond to Florida. However, the 2004 Singlehanded TransPac marked Barbara's first long-distance race — and passage — sailing solo.

Thomas Kirschbaum

Feral — International Folkboat
Los Angeles, age 55
Previous SHTPs: none

"I've been thinking about this since fourth grade, when Mrs. Fleming assigned Joshua Slocum's *Sailing Alone Around the World*," says Tom. He got his first sailboat ride — and sailboat (a San Francisco Pelican) — the next year and, well, it's all been 'downwind' from there. Fast forward 40 years to the summer of 1998, when "Everything came together," according to Kirschbaum.

"My older daughter and I sailed our Santana 20 from Marina del Rey to the unspoiled 'other side' of Catalina and had a great time. On our return, she gave me a copy of *My Old Man and the Sea*. I reread Slocum, and that same year I heard about the SSS.



"In 2002, I bought *Feral* with the idea that I might one day do the SHTP. Grandmothers have crossed oceans in these boats! We completed the 2003 and 2007 LongPac races and, after a few hard knocks — literally — and a lot of work, we're ready!"

Goals: 1) to arrive safely in Hanalei, with no mutiny, scurvy, or other sea adventures; 2) be able to enjoy the trip, whatever the conditions happen to be; 3) hobnob with some great sailors; and 4) to not finish dead last.

Jeff Lebesch

Hecla — Hammerhead 54
Ft. Collins, CO, age 54
Previous SHTPs: none

Jeff is the newbie of this year's group. Not only will the Solo TransPac be his first big ocean race, it will also be his



first ocean crossing. However, he's racked up a lot of coastal experience since learning to sail at Berkeley's OCSC in 2000, including sailing many solo miles on a 31-ft trimaran — to Alaska and the

Bahamas among other destinations. He moved up to the big boat last year.

"I've followed this event for years, and am attracted to it because of the well-developed rules and training options prepared by the SSS for singlehanded sailors," says Jeff.

Like several other competitors, he hopes to make the entire passage without using any fossil fuels for battery charging or cooking. Unlike many, Jeff says he'll rely on his triathlete training to help monitor how aggressively he's sailing. Although he intends to push himself and the boat to do well, "If I'm exhausted at the halfway point, I'll know I'm pushing too hard."

Dwight Odom

Na Na — Saga 43
Sausalito, age 70

Previous SHTPs: 1994, 2000, 2006

Like many before him, Dwight once thought one Solo TransPac was enough. "My 2000 race had great sailing conditions and everything worked very well with the boat. In short, it was such a perfect trip that I thought I would never need to go again."

However, after six years, it was obvious that the retired OB/GYN "needed another baby." So he entered the '06

race. For a number of reasons, he only got about 200 miles out before turning around. He's back in '08 to complete what he started, and to once again experience the magic of the Singlehanded TransPac.



"I love long ocean passages and being greeted by family and friends in Hanalei," says Dwight, who credits the main 'greeter', wife Mary, for getting him into this whole sailing thing — it was she who taught him to sail in Galveston Bay years ago.

Jeanne Socrates

Nereida — Najad 361
Hamble, UK, age: none of your business
Previous SHTPs: 2006

Jeanne started sailing in England in the early 1990s. In 1997, she and husband George flew to the Najad yard in Sweden to take delivery of *Nereida*. They cruised extensively in the Caribbean and U.S. East Coast. After George passed away in 2002, Jeanne kept going — in a big way. Last month, she tied the knot of a 15-month solo circumnavigation begun in March of 2007 off Zihuatenejo.

Jeanne was just passing through the Bay Area in 2006 when she met some singlehanders who talked her into entering the last Solo TransPac. Despite being becalmed for a week (along with most of the fleet), she enjoyed the race so much that she vowed to return in 2008. So as soon as she crossed her outbound track in Zihau, she was turning north for San Francisco.

"The last race brought out the dormant competitive spirit in me," she says. "And it made me get to know *Nereida's* capabilities far better than before. All in all, it resulted in a tremendous boost to my self-confidence, and was definitely one of the reasons for my extended wanderings since then."



Skip Allan

Wildflower — Custom Wylie 27
Capitola, age 63
Previous SHTPs: 1978

Skip is one of the most talented and accomplished sailors ever to come out of the West Coast. Just a few highlights

from his resume include tours of duty aboard the splendid 72-ft ketch *Ticonderoga* on her legendary '65 TransPac run; co-skippering the family's Cal 40 to a TransPac win in 1968; and skippering the famous Holland 40 *Imp* to wins of the '77 SORC and Fastnet Race.

Through it all, Skip has always had a soft spot for the Singlehanded TransPac.



He sailed in the very first one in 1978 — on the same boat he's taking again, the modified Hawk-farm *Wildflower*, which he built at designer Tom Wylie's shop in 1975. Skip has sailed this boat some 90,000 miles

since then, including two round trips to New Zealand, five to the Pacific Northwest and/or Alaska, and six to Hawaii — including an overall win of the 2002 Pacific Cup as a doublehanded entry.

"I'm sailing this race again, 30 years after the first one, because the boat is due for another long passage, it's the 30th anniversary of the race — and because Hanalei Bay is the best place in the world to finish an ocean race."

Eric Thomas

Polar Bear — Olson 30
Duluth, MN, age 37
Previous SHTPs: none

Eric has been messing about in boats all his life. In fact, actually a bit before his life: "Something about my mother water skiing at eight months pregnant causing 'water on my brain' — or so they tell me," he says.

But seriously, his family raced and cruised the Great Lakes in a variety of boats as Eric grew up. Sailing on the University of Wisconsin sailing team and multiple trips south in the winter to race, round out the big picture. His solo sailing began in college "when I would run out of patience waiting for friends to show up on the few warm days we would get on Lake Superior," he says. This led to local solo day races and, eventually, the Great Lakes Singlehanded Society's races on Lakes Huron, Michigan and Superior.

And now he's sailing across the Pacific. "See?" he says — "Water on the brain!"



Bob Johnston

Ragtime! — J/92
Benicia, age 51
Previous SHTPs: 2006

If there is a trend among Solo TransPac 'repeat offenders', it is that the first time you do the race, you "cruise conservatively for the experience." From then on, you race. That's the situation with Bob, who says his first SHTP in 2006 (which was also his first-ever visit to Hawaii), was a feeling of accomplishment that can't be described, from start to finish. Yet it was only after he arrived that he fully understood what some of the veterans had told him about the event. "Lou Freeman said that we all get amnesia between races. And he's right. I'm so excited about doing this year's race that I barely remember being becalmed for days in the last one."

Mark Deppe's remark that "There's something addictive about this behavior" also proved spot-on.

"I hadn't planned to do this race again until 2010. But almost since I got back, I find myself buying boat parts on eBay, jamming myself under the cockpit to drill holes and run wiring, and otherwise anticipating the July 12 start."



Don Gray

Warriors Wish — Jutson 30
Oriental, NC, age 60
Previous SHTPs: none

Don had his first sailing experience in England at age 24. Since then, he's sailed everything from dinghies to offshore racers. He particularly enjoys singlehandeding, and decided last year "if I was ever going to really do it, I better get going." He set goals to do the 2007 Bermuda 1-2, the 2008 Singlehanded TransPac and the 2009 Transat.

In searching for a boat that met his needs and budget, it wasn't long before he ran across the Jutson 30. Originally built to the Mount Gay 30 box rule, the water-ballasted *Warriors Wish* had been sitting in storage a while and was in good shape. Don did a few modifications to make the boat more friendly for singlehandeding — among them trading in the boat's symmetrical kits (and 15-ft spinny pole) for a 4-ft sprit and assymetricals. Thus outfitted, Don took second both going and coming in the Bermuda 1-2 last June.



There are other, more worthy goals. *Warriors Wish* is named after a program within Hope for the Warriors, a nonprofit organization whose mission is to enhance the quality of life for U.S. service members who have been injured in the line of duty, and for the families of those warriors who have made the ultimate sacrifice. "As a Vietnam era Marine, this program means a lot to me, and I am proud to be a board member," says Don.

Ruben Gabriel

Sparky — Pearson Electra
Benicia, age 42
Previous SHTPs: none

"Hanalei Bay, Kauai, is my favorite place on earth — no joke — and to have an opportunity to arrive by sail, in a race, is too amazing!" says Ruben.

As with all new participants, Ruben quickly learned that the race itself is just one part of this event — and a relatively small one at that. "Just wanting to go is not enough. I've learned that the reality is the huge amount of preparation that's necessary — and the huge amount of help and support I've gotten from friends, family and the SSS. It's already been a life-changing experience, and the race hasn't even started yet! Or has it?"

Ruben will be sailing the race's second-oldest boat, his 23-ft Pearson Electra *Sparky*. "She was built in 1962, so she's been around longer than me, but she is strong, capable, beautiful, and an absolute joy to sail!" he says. "I believe I may be the 'slowest rated' boat in the fleet, but with new Pineapple sails and a sprayed racing bottom, I'll sail *Sparky* as fast as I possibly can and hopefully worry at least a few of my competitors."



Jim Kellam

Haulback — Spencer 35
Vancouver, age 56
Previous SHTPs: 2002, 2004

Jim is another one who has fallen under the spell of the Singlehanded TransPac. For years a fan of long-distance sailing, Jim did the '02 and '04 races. Then — get this — after the '04 Solo TransPac, he sailed *all the way around*

2008 SINGLEHANDED TRANSPAC PREVIEW



the world with only one mandatory stop: he wanted to be back in Hanalei in time to greet the '06 fleet. To everyone's surprise and delight (including ours), come July,

there was good old *Haulback* in the anchorage, and Jim greeting each boat as they finished.

Jim's goals for '08, in no particular order, are: beat my previous best crossing of 16 days, catch more fish and find a glass ball on the way over.

Wen Lin

Wenlemir — Swan 47
Tiburon, age 70

Previous SHTPs: none

Sailing and a lifetime love of the sea go hand in hand for Wen, who learned to sail as a high schooler in his native Japan. After relocating on this side of the Pacific, he continued to evolve as a sailor with new boats and new venues: a Cal 20 in Vancouver, an Aries 32 in Marina

del Rey and, finally, the pretty Swan 47 *Wenlemir*, which he bought after moving to Northern California in 1991.

"This boat was a handful for one person at the start, but as we sailed together, it became my companion and friend," says Wen. In 2000, he singlehanded her from the Bay up to British Columbia, where he was joined by his wife for a season of cruising the beautiful Northwest. They liked it so much that he'll be sailing the boat back there after the Solo TransPac for more exploring.



Wen started the 2004 Transpac, but had to drop out due to health issues and some weather-related damage. He returns this year, both to complete

that unfinished business, "and to regain my optimism of life" after the passing of his parents last year.

Nicholas Ratto

Kali O Kalani — Hawkfarm 28
Alameda, age 41

Previous SHTPs: none

Nick's interest in boats started about age 6, but it wasn't until he went to college and started dating a girl who had cruised Mexico and the South Pacific with her family that he really got interested — in sailing, that is. He convinced some friends (non-sailors, all) to go into partnership on a 40-ft wooden sailboat that had formerly been a live-aboard for a family of four people, one dog and a diabetic cat. "Needless to say, it needed some work," he recalls. But they lived aboard, worked on it a lot and, somewhere along the way, taught themselves to sail.



"It was a great learning experience and led to other boats, cruises, some racing on the Bay — and being part of this race."

SCHOONMAKER POINT MARINA

• IN SAUSALITO •



Call the Marina Office
for more information

415•331•5550

FAX 415•331•8523

or check our web site at

www.schoonmakermarina.com

85 LIBERTY SHIP WAY, #205
SAUSALITO, CA 94965



"Sausalito's finest Marina"

160 Berth Marina in one of the most beautiful spots on the Bay

- Visitor berths • Guest moorage able to handle yachts up to 200 ft.
- Dry storage • Waterfront Offices • Three-ton Hoist • Windsurfing
- Deli • Beach • Rowing • Kayaking • Yacht clubs always welcome

Sailors aren't alone



with an Alpha pilot onboard

Ultra-Low Power Consumption – Reliable – Accurate

For 35 years, Alpha has been delivering the reliability, performance and low power consumption offshore sailors have demanded.



Alpha Marine Systems, Inc.

Call the quality leader... **1-800-257-4225**

or visit us on the web at www.alphamarinesystems.com

Launching in June 2009

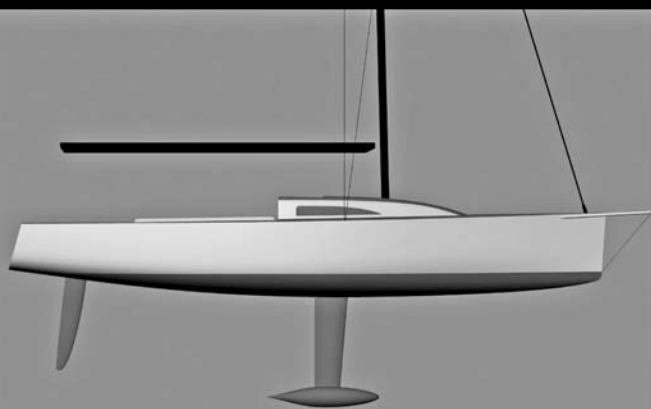

LS-30

LOA 27 ft 10 in	Draft 6 ft	Displacement 4,073 lbs	Rigging Carbon	Hull Cold-molded	Power Inboard diesel
--------------------	---------------	---------------------------	-------------------	---------------------	-------------------------



The Landing School

www.landingschool.edu

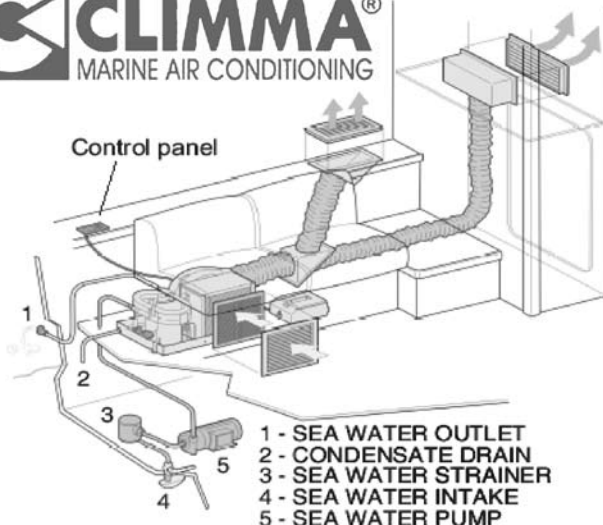

SUMMER AIR CONDITIONING

Quiet • Cool • Efficient

Stainless steel base and brackets for long life in the harsh marine environment. Quiet, high efficiency Carrier compressor for low running and starting current. Exceptionally low current draw – can easily be powered from batteries through inverter.



SWEDISH MARINE

1150 BRICKYARD COVE RD., SUITE B6
PT. RICHMOND, CA 94801 (510) 234-9566

EYE ON THE BAY

— **W**ith all due respect to Stephen Stills, if you can't sail with the ones you love — just go out with anybody.

Let's face it, unless you're one of those lunatic fringe singlehanders, any meaningful life experience is better when you share it with someone else. And according to recent research, sailing leaves more indelible memories than any other pastime. Okay, okay, we just made that

up. But think about it: of the top five best memories of fun outings with family and friends that you've had in the last 20 years, how many involve sailing? Now, how many involved croquet? See? (Margin of error in this poll: $\pm 3\%$.)

We have taken many people sailing
continued on page 148

The unvarnished truth: going sailing with friends is always better than working on the boat.

PHOTO: PETER LYONS/WWW.LYONSIMAGING.COM



— THE BUDDY SYSTEM



EYE ON THE BAY

PETER LYONS/WWW.LYONSIMAGING.COM



PETER LYONS/WWW.LYONSIMAGING.COM



Just between friends (clockwise from right) — the 'Spray' replica 'Bertie' spreads her wings and takes flight; in the Bay you have big friends and little friends; 'Xarifa' in the rinse cycle; it's not just two-legged sea dogs who enjoy sailing; 'Bo power; trading tacks with FDR's floating white house 'Potomac.'



— THE BUDDY SYSTEM



PETER LYONS/WWW.LYONSIMAGING.COM

EYE ON THE BAY

over the years. It's one of the funnest aspects of this whole crazy deal for us. And getting folks out who have never been sailing before is usually the most fun.

Unlike the old days when we used to like to give them the 'full experience' by basically scaring the bejesus out of them, these days we go to great pains to make the experience a memorable one for all the right reasons. Plus we don't lose as many friends as we used to.

So it's the classic Bay tour — out under the Golden Gate in mid-morning, when the wind's just coming up, followed by an easy run down the Cityfront, then a spray-drenched white-knuckler across the Slot, followed by the wine and cheese thing at anchor off Angel Island. (If this sounds familiar, that's because we detail it every spring in our *Guide to Bay Sailing*. Taking friends sailing is one of the main ways we developed it.)

Even if it doesn't seem like it at the time, a day like that can live forever in someone's memory. During the holidays last year, when we had the chance to meet up with (nonsailing) friends that we hadn't seen and barely talked to in a



Ferry wakes can't be helped, but if you're taking newbies out, try not to scare them too much. If they do get scared or queasy, head downwind and take a break.

decade, one of the first things they did was thank us for a day like the one we've just described, calling it one of the best days of their lives. And this was before we even spiked the eggnog.

So next time you get the hankering to go out with friends, invite a few new

ones along — or invite the friends to invite someone. It doesn't matter who — neighbors, kids' friends, kids' friends' parents, the couple you met on the dock that morning, the local mechanic who's always treated you right, the latest Facebook Friend . . . the 'who' doesn't really matter. What matters is that you're giving something to someone, and that the thing you're giving is a gift that might just be remembered for a lifetime.

More Fun in the Great Outdoors!





Wheel-a-Weigh® Dollies
Get your small boat or kayak to the water quickly and conveniently!



Whale Tail XL® Aluminum Stabilizer & Ski Boat Fin
Improves performance on any I/O or outboard motor. Transforms prop wash energy into lift, reducing wake and popping skiers up quicker. Saves fuel, too!



Improved!
Windex® 15 Wind Indicator
The standard on most mastheads around the world. Now with bird-proof spike!



Air-Dryr™ An inexpensive and effective way to fight mold, mildew, moisture, corrosion. Silent, low-cost operation.



WindScribe™ Ultrasonic Wind Meter
Compact unit measures wind speed from 0–150 mph. Patented ultrasonic technology means exceptional accuracy—and no moving parts!



Wheel-a-Weigh® Launching Wheels
Get your small boat or inflatable to the water quickly and conveniently!



New!
Vantage Pro2® Wireless Weather Station
Breakthrough technology transmits weather data wirelessly 1000 feet! Large LCD display provides graphing and forecasts. Sensor suite measures rain, temperature, humidity and wind.



Davis Instruments
3465 Diablo Ave., Hayward, CA 94545 U.S.A.
800-678-3669 • sales@davisnet.com
www.davisnet.com

New Member Showers and Laundry Facilities Now Open!

Emeryville Marina

ON THE BAY

NEW SLIPS!

Now taking reservations
40' to 60' - available
Fall/Winter 2008

*When you call Emeryville Marina Home...
...call this your backyard!*

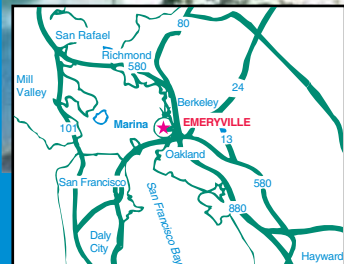

MARINAS
International

Slips from 20-65 ft
Full Amenities - including
Fuel Dock & Pumpout Station

(510) 654-3716
www.emeryvillemarina.com



wallas®

SAFEFLAME

85DU/270
Marine Diesel
Stove with Heater Lid

2,000 to 6,650 BTU



UNIQUE EFFICIENT DESIGN

- Safe no-open flame operation.
- Exhaust vented outside, helps keep cabin dry.
- Lid up: cooking. Lid down: cabin heating
- Superb marine grade construction, great looking.
- Easy to install, either flush or surface mounted.
- Super clean, variable output combustion process.

CE

Importer & Distributor for North America:



ScanMarine
EQUIPMENT

2144 Westlake Ave N Suite D
Seattle, WA 98109
Ph: 206-285-3675
Fax: 206-285-9532
info@scanmarineusa.com
www.scanmarineusa.com



Newest Technology for Bottom Paint Stripping Offered by Surface Restoration Group

- ◆ Using the Farrow System® designed for use in boatyards and marinas to strip paint from Fiberglass, Wood, Steel and Aluminum hulls for supreme paint adhesion.
- ◆ Remove years of paint coatings for better performance and speed. Reduced drag, weight, and increased fuel savings.
- ◆ Fast – Cost Effective – Green Technology – Precise Control.

Visit website or call for further information

www.surfacerestorationgroup.com
925 998-9902

PACIFIC CUP 2008 PREVIEW

There's an undercurrent of resurgence pushing this year's Pacific Cup. Not only is the event rebounding from 2006's 43-boat turnout — the lowest since 1986 — but it's doing it with some bling! This year's field of 61-boats includes a fully-tickled SC 50, a late-model TP 52, a year-old Antrim 40, and what's probably the fastest 45-ft keelboat ever built. Along with all the bling, there are other efforts worthy of a mention for different reasons. The only thing we regret is not being able to get to them all.

The "Broken" Boat — *Checked Past* is a customized Wyliecat 39 belonging to Chris Gibbs. Originally from the Bay Area, Gibbs will be sailing under the burgee of Richmond YC, but lives in Hamburg, Germany where he owns a store that sells high-end motorcycle leathers. He made an attempt to do the Atlantic Rally for Cruisers this past winter but when the boat wasn't ready in time, he was forced to abandon the plan and was left with a dilemma. He'd had been sailing the boat on the Elbe River and Baltic Sea, but they just weren't doing it for him anymore. So when he got the commitment of long time friends Grant Donesley, Geoff Ashton and Gibbs' father, Larry, the choice was clear — ship the boat to the Bay for the Pacific Cup.

Gibbs has known Ashton and Donesley since they were in the merchant marine together, he said, between trading barbs with his wisecracking crew as we talked about their trip. "When they said they were up for it, the decision was made."

There's just a couple quirks to this tale. The first is that Gibbs is paraplegic and needs a wheelchair for mobility. He credits the boat's designer, Tom Wylie, and builder, Dave Wahle, with creating the perfect platform to allow him to



continue sailing. Wylie designed some modifications, like a wickedly simply companionway elevator with dogs for Gibbs' wheelchair wheels, that slides on ball-bearing traveler tracks and can be easily raised by hand with the 4:1 ratchet tackles on either side.

"It's our fitness program on the way to Hawaii," Gibbs joked. "We don't want any atrophy on this boat. But seriously, Tom did a great job of not making it look 'handi-capable' or some horrendous shit like that."

That elevator, coupled with a swiveling race car seat mounted to a carbon fiber tube which plugs into the cockpit floor and weighs maybe 20-pounds all up, makes the boat open enough that Gibbs can negotiate almost every inch of it from his wheelchair.

When it came time to work on the interior, Wahle stepped in. He used a vegetable pallet and a forklift to lift Gibbs up and inside the boat the boat where Wahle,

told him, "You wheel around, and I'll follow you with a chainsaw." The result is an open layout that easily accommodates Gibbs' chair.

Another quirk? Larry Gibbs recently had a steak-sized tumor removed from his back. Another? Ashton is a survivor of both testicular cancer and Lymphoma. And Donesley? Well, he survived two strokes after a blow to the head from his surfboard caused a bloodclot to form in his brain. And the final quirk? These guys are racing for a win in Division B, not a pity party. That's if the group that refers to itself as the "broken" boat can keep from getting in fights over the helmsman's chair.

So what's Gibbs looking forward to the most?

"When's the last time you got to go 18-knots without a bunch of dickheads in matching shirts screaming at you?" he asks. And guess what he said they'll be wearing for the trip. "Totally — matching shirts."

Unfinished business — Encinal YC's Rodney Pimentel is looking at this year's

A 'Checked Past' with a mai tai future — (l to r) Larry Gibbs, Grant Donesley, Chris Gibbs and Geoff Ashton.



LATITUDE/ROB



Above, 'E.T.' will be back to try and repeat as a division winner — with a new crew for co-owner Todd Hedin. His wife, Liz Baylis, is skipping the Pac Cup to go match racing and designer Jim Antrim will be aboard the Barran Family's 'XL'. 'Azure' (below) and skipper Rodney Pimentel will be looking to improve on their 2005 Transpac showing.

LATITUDE/LADONNA

Pacific Cup as a chance to improve on his first crossing in his Cal 40 *Azure* — the 2005 Transpac — which didn't go as well as he would have liked when they finished 10th in their division.

"We learned our lessons on routing," he said. "We were very green, but we learned a lot, licked our wounds and we're ready to try again."

Pimentel has again recruited childhood-friend Ted Floyd to navigate while adding Coastal Cup daredevil Michael Andrews, who's not only won the national championship in the Santana 22 class, but also raced his down the coast. Pimentel feels that this balance should put them in the hunt.

"We're looking for a good, big-air Pac Cup, where the Cal 40 can show its stuff and hopefully shine."

Another motivator — Sailing her Express 27 *Elise* to Hawaii this year will be Nathalie Criou's just reward for having to endure a less-than auspicious last couple of years. In 2006, Criou was aboard the Barran family's ILC 40 *Muriedretta XL* on the way home from Kaneohe Bay, when a whale struck the boat and sunk it 400 miles from Hawaii.

Criou was barely done surviving that when she was confronted with another life-threatening situation. Criou — who will be sailing the race with Nathan Bossett — was diagnosed with Sarcoma, a rare cancer. After a year of treatments that made work and sailing impossible, she's a survivor who's dedicating her trip and her efforts to raising funds and awareness for Sarcoma research.

As part of a multi-pronged effort, Criou founded the first annual Sarcoma Cup which was sailed June 28-29 at Richmond YC. We went to press before the event, so we can't tell you what the outcome was. What we can tell you is that we're impressed. Sailing has redemptive value beyond trophies and it's efforts like this that remind us of that.

As of this writing, a reassessment of the division assignments and start dates was still in process. The Pacific Cup Yacht Club wisely chose to reevaluate the division breaks when it was realized that displacement boats were mixed in with ULDBs unnecessarily among the smaller boats. So, we're going to be making our winners picks without knowing if the divisions will stand. But, what the hell — this 2,070-mile classic only comes around every two years. Keep in mind, we're making these subjectively and hoping to disprove the myth of the "Latitude 38 jinx." So here goes:

Doublehanded 1 — (starts July 14) In this division we see Richmond YC/Seattle YC's Paul Disario and his Olson 911 *Plus Sixteen* winning. Disario and Tony Porche finished second in the Doublehanded Division in 2006 and their main competition that year *The Contessa*, is in the new Doublehanded 2 Division this year. None of the other boats apart from the SC 27 *Giant Slayer* are back this time, so look for Disario and Porche to romp.

Doublehanded 2 — (starts July 15) Speaking of *The Contessa*, the Swede 55 is a favorite, but with a catch. In 2006, she only had one Moore 24 to deal with. This year she's got three, plus Dylan Benjamin's Dogpatch 26 *Moonshine*, which took overall honors in the 1994 race under original owners Bill and Melinda Erkelens. If it's a moderate year, and the big boat can put her waterline to use, Shawn Throwe and Neil Weinberg should be able to hold the ULDBs off. But, with this year's race starting three weeks later, we're betting on full-blown surfing conditions and Mark Moore with Rowan Fennell on the Moore 24 *Moore Havoc*.

Divison A — (starts July 14) There are four strong Cal 40 efforts here. Pick one. Ours is Timm and Victoria Lessley's *California Girl*. They've won their division in the last two editions of the race, although there'll be a lot more competition for them this year with two additional Cal 40s boats compared to 2006.

Divison B — (starts July 15) We're going to have to go with *Checked Past* in this division. Chris Gibbs has an experienced crew and a simple platform that can gybe on any shift it likes without slowing down, breaking stuff or waking the off-watch.

Divison C — (starts July 15) Michael



PETER LYONS/WWW.LYONSIMAGING.COM

PACIFIC CUP 2008 PREVIEW

Maloney's Express 37 *Bullet* out of the Berkeley Yacht Club is well-sailed and has the least amount of furniture as far as we can tell.

Division D — (starts July 16) This group is packed with talent and preparation. There's also a bit of a waterline gap. If the breeze is moderate, Wayne Zittel's *J World J/120* entry could get a jump. With class wins in the Ensenada Race and the Doublehanded Farallones Race, Dean Daniels' Hobie 33 *Sleeping Dragon* could pose a threat. But, we're going to go with *E.T.* because we think that after three wins, co-owner Todd Hedin has the chops to win without his wife and co-owner Liz Baylis, and Jim Antrim.

Division E — (starts July 17) This is a tough, tough call. In light air, Chris Calkins and Norm Reynolds' Calkins 50 *Sabrina* is as pretty as she is slippery. We happened, randomly enough, to sail aboard her under previous ownership on Puget Sound and can tell you she'll sail to her PHRF rating. If she doesn't get hurt by the Pac Cup ratings, she just

might reprise her overall Corona Del Mar to Cabo San Lucas Race win earlier this year. Yes, we know Paul Cayard is in this division. If the breeze comes up, his SC 50 *Hula Girl* should scream. But, we have to think that *Hula Girl's* rating will be pretty steep on account of all the performance modifications the previous owner made — too steep for a SC 50 in the kind of conditions they seem to excel in. So, we're picking the Barran Family's Antrim 40 *XL*. Are we crazy betting against a Volvo Ocean Race winner? Probably, but we really like *XL*. She has an extremely efficient sailplan, a displacement of only about 10,000 pounds, a more modern hull form, and we're banking on the fact that Harry Pattison and Jim Antrim will be on opposite watches. We think the boat fits a broader range of conditions and should really smoke downwind in the breeze. Given that the race is starting three weeks later this year, we're going to hedge our guess for more breeze and go with *XL*.

Division F — (starts July 19) With world class navigator Adrienne Cahalan joining Brack Duker's crew of Dave Ullman, John Fuller, Brent Ruhne, Mike Herlihy, Keith Kilpatrick, Mark Sims and Sam Heck, the SC 70 *Holua* is our pick to win this division. In fact, we think there's probably an attorney who would charge that Duker's violated the Sherman Act by hoarding all that talent. He or she would lose, because there's a lot of other talent in the division, principally on Mark Jones', Dick Watts', and Peter Stoneberg's late-model TP 52 *Flash*, and Chip Megeath's R/P 45 *Criminal Mischief*, which offshore is quite possibly the fastest 45-ft keelboat on the planet and will be navigated by '06 winning navigator Jeff Thorpe. Still, we have to go with *Holua* though, believing that they've got age, wisdom and enthusiasm going for them.

First On Elapsed Time — *Flash*
First Overall — *Moore Havoc*

See you in Hawaii!

— latitude/rg

APS
"The Raceware Specialists"

KNOWLEDGE
- Shop Where Fellow Racers Work

CONVENIENCE
- Online Orders Save on Shipping
- Same Day Shipping
- Speedy Custom Rigging

SELECTION
- Largest Selection of Racing Hardware, Apparel, & Cordage In the World...Online and In Stock!

www.APSLTD.com ~ 800.729.9767



Easy to handle

e – built in epoxy | design by judel/vrolijk & co



320 New 350 New 370 e-option 400 e-option 430 e-option **470e** 540e 630e

Hanse Yachts US

410-626-1493 | dwalsh@hanseyachts.com

NorCal: Larry Mayne Yacht & Ship | 650-888-2324 | maynesails@aol.com

SoCal: Bower & Kling | 619-226-7797 | rkling@ix.netcom.com

INNOVATION – SPEED – COMFORT

- ⚓ Ground breaking interior design
- ⚓ Multiple layout options (see our Individual Cabin Concept)
- ⚓ Modern, award winning performance cruisers
- ⚓ Self-tacking jib engineered into the HanseYachts design
- ⚓ Epoxy hulls (option up to 43 ft)
- ⚓ Safe, comfortable, fast & easy to sail

Hanse 
www.hanseyachts.com

**WE SPEAK
SSB
EMAIL**



HF Radio On Board has sold thousands of trouble-free Icom SSB email systems. Get yours online at www.hfradio.com.



510.814.8888
info@hfradio.com
www.hfradio.com

Official Sponsor
**2008
BAJA
HA-HA**

MARINE COMMUNICATION SOLUTIONS FOR EVERYONE, EVERYWHERE



Keelboat
Certification
System

*Let us show
you the ropes*

Find a US SAILING accredited school near you:
call 1-800-USSAIL-1 or visit
www.sailingcertification.com



Photo courtesy of Billy Black Studios

You dream of learning to sail and charting a course to an adventure of your own. At US SAILING, superior instruction and hands-on training come together under the direction of the most qualified instructors at the country's top sailing schools.

Accomplished sailors start here.

MAX EBB

I had almost forgotten how bright the stars can appear after the moon sets and you are a thousand miles from land and the nearest city lights.

We were well into the trades, and I was alone on watch, steering down long round swells before a fresh breeze. The air had warmed up enough to forget about the foulies and fuzzy hats, even at three in the morning.

I had dimmed the instrument lights so the compass card and the stars were the only objects clearly visible, and even the compass card was superfluous. My instructions were to steer "whatever feels like the best VMG downwind," and "wake me up if we're lifted more than 10 degrees."

"What's our course?" Lee Helm asked from the companionway, dispelling the illusion I was one with the universe.

"Headed down five," I answered. "And the wind's up a little. Good sailing."

"Um, have you, like, looked behind you lately?"

"No, why?" I asked as I turned to look back at our invisible wake, expecting to see a ship or another sailboat that I should have noticed.

"Can't see a thing."

"See that big patch of sky?"

"You mean that big black area with no stars?" I said.

As I spoke I realized that there should be stars everywhere, and a big patch of nothing but black could only mean one thing: a massive cloud formation was overtaking us from astern.

"I'll wake up Radar," said Lee.

'Radar' was the most novice sailor in the crew, but he had done some time on anti-submarine aircraft, and loved to use the radar. Fortunately, this boat was equipped with a 250-watt solar farm, so the power budget allowed him to play with his favorite toy to his heart's content. He had been waiting for this moment since the start of the race.

"We have visual on a possible target," I heard Lee explain as a red flashlight beam flickered

around the starboard quarterberth.

"Cool! I'm on it!"

The indirect light from the nav station confirmed that the radar was warming

up. Meanwhile, the area of the sky behind us with no stars was getting taller and wider. Lee reflaked the spinnaker halyard to make sure it was ready to run out fast without a tangle.

I hadn't thought I would be sailing to Hawaii this summer, but Lee Helm had mentioned that she was going to the bon voyage party, and that there were often some last minute crew spots to fill. She insisted I come along.

Sure enough, there was a big fast boat on which one crew had a sudden emergency at work and another had an old back injury flare up. Lee swept in like a vulture. Just three days before the start, they signed me on as navigator and Lee as foredeck crew. Although, as it turned out, Lee was calling the shots.

"Target acquired," reported the radar tech. "Solid return, there's a big rain core in this one."

He gave us the range and bearing to the center of the approaching squall.

"Let's head up 15 degrees," said Lee.

She trimmed the sheet and foreguy

as I eased the after-guy forward from the helm. Speed jumped up a knot on the new course, although now we were giving away some VMG downwind.

"Should we have more people on deck for this?" I asked as I looked back again at the big black patch, now expanding



across the sky at a faster rate.

"Who's on watch with you?" asked Lee.

"I sent the owner down early because he was up all through his last off-watch trying to fix the watermaker. Let's call up the standby."

Lee went below and flashed a light in the face of the crew in the port pilot berth, and he confirmed in a groggy voice that he would be on deck in a minute.

"Sure would be more convenient if the squalls came during daylight," I said

"Doesn't work that way," said Lee.

"During the day, when solar heating at the surface makes the air unstable, the updrafts are stronger than the down-

RULES OF SQUALLS

- Squalls sail on starboard tack (except when they don't).
- Wind in the squall is a right-hand shift (except when it isn't).
- A header might mean the edge of the squall wind (except when it doesn't).
- Exit stage left (except for left-handed squalls).
- Squalls move at half the speed of the wind in the squall (except when they move faster or slower).
- Stay away from squalls at dawn (always true).

— SQUALL OF THE WILD



Squalls act tough but, with a bit of practice, they can be reasoned with. Not so with some weather bullies, such as this waterspout that scattered the Sydney-Hobart fleet in 2001. Thank goodness none of these bad boys have been reported on Hawaii races.

drafts. At night, when everything cools down, we get the big downdrafts that turn into the wind gusts in front of the big squalls."

"Somehow I imagined tradewind air would be stable at night," I said.

"Only when the temperature gradient is, like, less than the adiabatic lapse rate," Lee corrected.

"The what?"

"Adiabatic," Lee explained, "means no

heat going in or out."

She didn't need daylight to detect my baffled expression.

"If you take some air," she explained patiently, "and move it up to a higher altitude where there is less pressure, it will expand. And expansion of a gas causes it to cool. Think of a box of air. If you expand the box, the molecules of air will bounce off a surface that's moving outward every time they hit an expanding wall, so they bounce back at a slower speed, and slower moving molecules means lower temperature. The adiabatic lapse rate is just the natural cooling rate of air as it rises. Typically around five degrees per thousand feet for dry air."

"Okay, but what does this have to do with squalls?" I asked cautiously,

wondering if it was really a good idea to encourage her. We should have been preparing for an impending disaster — or at least a fire drill — before the squall hit.

"Stability of an air mass is determined by comparing the actual vertical temperature profile of the air mass to the adiabatic lapse rate," she said as if this should be obvious. "If some air moves up just a little, it cools just a little, at the adiabatic rate. If the surrounding air at the higher altitude is even cooler than the air that just moved up, then the air that moved up finds that it's now warmer than the surrounding air."

There was a pause, as if that last statement was supposed to explain everything.

"And?" I finally asked.

"If air is warmer than the air around it, it's buoyant! It floats up even more! Then the temperature difference is even greater, so it floats up faster, and you have a rising column of unstable air. You know, like, a thermal."

"In other words," I suggested, "warm air rises."

"Yes, but it always cools as it rises, so to keep rising, the ambient air around it has to get cooler faster than the rate at which the rising air cools."

"Let me work on that for a minute."

But Lee was not about to leave it there.

"The situation is more complicated when you add the effects of moisture," she continued, with obvious enthusiasm for the subject. "As air goes up and the pressure and temperature drop, the air can hold less water vapor. So water starts to condense out, and the latent heat of vaporization is released. The air is essentially heated by condensing steam. That's why the adiabatic lapse rate for moist air is less — more like 3.5 degrees per thousand feet. Then it's much more likely to find an ambient lapse rate that's steeper, so it's much more likely to be unstable air. That's why we get a stronger sea breeze in the Bay when the humidity in the valley is high, and why squalls form over water, and why glider pilots look for cumulus clouds."

I probably could have followed this reasoning if I could have given it my full attention, but it was difficult to take my mind off the ever-expanding patch of black sky that was almost on top of us.

The standby crew joined us on deck, tested his strobe light, checked the batteries in his little personal VHF and clipped in his harness tether.

LATITUDE ARCHIVES

MAX EBB

Radar called out new vectors for an intercepting course, and the stars directly overhead were blotted out.

"If these towering cumulus clouds are made by unstable air going up, what the heck is this thing that's about to hit us?" I asked.

"What goes up must come down," Lee noted. "When moist air cools and starts to sink, the pressure and temperature increase, so liquid water drops in the clouds can evaporate, and the evaporation keeps the air from heating up as it sinks faster and faster.

Instead of steam heat, we have air conditioning, and we get the cold downrush column typical of a strong squall."

I felt a few drops of rain, and then the wind hit. It went from high teens to high twenties in a few seconds. And as if the squall had been listening to Lee's lecture, the temperature dropped about

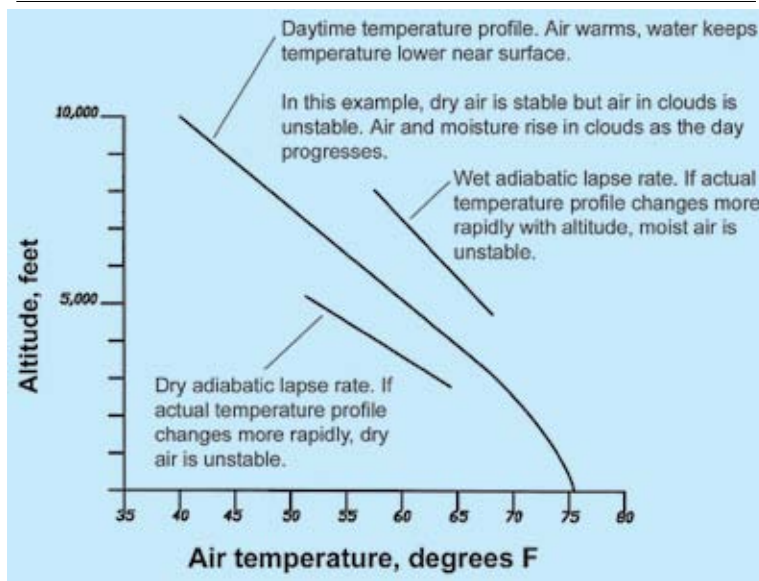

20 degrees. The boat, an ultralight fitted out for cruising but still capable of high speeds before a good blow, took off on a very fast deep reach on starboard tack.

"It's a big righty," shouted Lee. "We're lifted big time. We should jibe on this."

the pole tip up to the port spinnaker clew and transferred load to the afterguy. We now had both spinnaker clews locked in place at the two pole tips.

"Anytime," they called to me as they moved to the mainsheet. "Just don't dip either of the poles."

I turned, they hauled in the main

SURVIVAL TECHNOLOGIES

MOM8-A[®]



Man Overboard Module

Manufactured By



Switlik Parachute Co., Inc.
Trenton, NJ

609.587.3300

info@switlik.com

BETA MARINE

Our engines idle smoother and quieter because of our high inertia flywheel. This is one of the many Beta Marine exclusive features that make our diesel engines easier to live with.



SMOOTHER... QUIETER!

What a Concept! It is engineered to be easily serviced.

Beta Marine superb propulsion engines, using Kubota diesel 10-90hp including our famous Atomic 4 replacements.

Also available: Marine Generators up to 30 kw.

California Distributor:

HIRSCHFELD YACHT LLC

265 Gate 5 Road, Sausalito, CA 94965

www.engineerite.com

www.betamarine_west.com

(415) 332-3507

— SQUALL OF THE WILD

until it slammed over, and we were going full speed directly toward the finish in 27 knots of wind. We transferred the load from the starboard afterguy to the starboard sheet and secured the starboard pole.

"Close the hatch!" shouted Radar as another heavy rain shower overtook us.

"Pass up some soap!" joked Lee as the rain intensified.

"The old ditty about squalls is right," said the standby crew as the true wind hit 30 knots. . . .

"First the rain and then the wind,

Tops'l sheets and halyards mind.

First the wind and then the rain,

Hoist your tops'ls up again."

"Gag me!" complained Lee. "That's got not one, but two illegal rhymes in just four lines."

"Works at least as well as 'red sky at

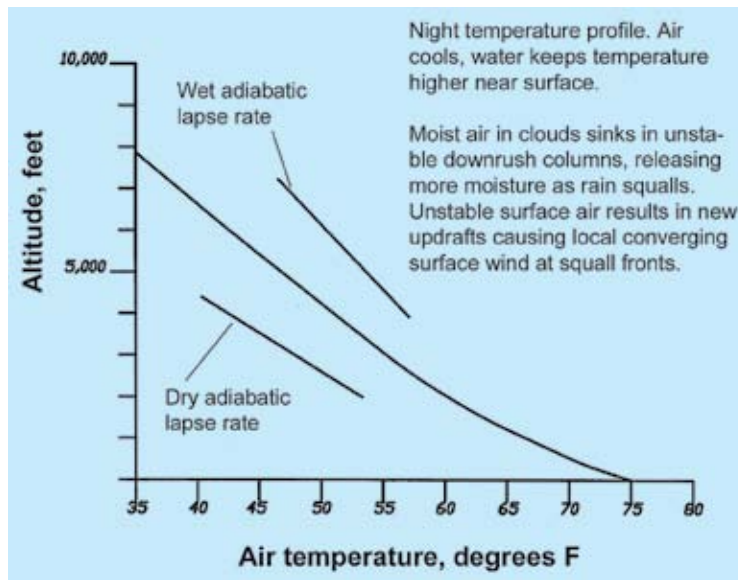

night," insisted the crew.

The wind intensified even more. I could tell that Lee desperately wanted to take the helm from me. But it always

feels less scary if you're the one driving, and the boat handled the speed just fine. After a few minutes, the worst of it had passed.

"How's our course?" asked Lee as she wiped raindrops off the compass dome.

"Headed down a little," I said. "And the wind's down to 20. I can sail hotter and still be right on rhumb-line."

"That means we better jibe back," she said. "The wind often heads a little right on the boundary of the squall breeze."

Imagining the squall as air sinking down the middle

of the collapsing column of clouds and fanning out horizontally as it hit the surface, this seemed all wrong. It made more sense to me that the wind would lift, not head, at the boundary of the squall wind. And I couldn't see jibing away from a fast reach that was taking us directly to the finish line. But Radar confirmed that we

Can Your Insurance Company Measure Up?



Policyholder Willow Link and Florida Claims Rep, Salandra Dawson

"On our way back from Florida to Lake Erie, a sudden 35 knot wind forced us into another boat's anchor flattening our dinghy! This safety item had to be replaced for our trip to continue. Salandra, a BoatU.S. Florida Claims Representative, saw that our check was issued within days and drove her own car to the coast where we were waiting..."

BoatU.S. has been insuring boats and caring for boat owners for more than 40 years. All policies come complete with unparalleled claims service and peace-of-mind coverage that you won't find with other insurance companies.

"...BoatU.S. exceeds expectations by demonstrating concern for their customers—truly the measure of a good, trustworthy insurance company."

— Willow Link, BoatU.S. Insured



All policies are subject to limits and exclusions.

For a fast, free quote, call
1-800-283-2883

priority code 4848

or log-on to **BoatUS.com/insurance**

MAX EBB

were in fact at the edge of the action, so we jibed back to starboard.

Lee was right, our jibe put us right back into the full strength breeze. We jibed across the face of the squall three more times before the wind finally started to fade, and we sailed out of it on port pole.

"Exit, stage left," Lee advised, quoting a cartoon character that had been off the air long before she was born.

"Why left?" asked Radar from the nav station. "We might get one more good blast of air if we sail through it again."

"Exit left takes us away from the tail end of the squall faster, and if we're lucky, we'll escape the calm spot in back where the squall wind and the trade winds cancel out."

"But why is the port exit any faster than the other side?" asked the standby crew. "Don't we expect to end up back on starboard when we're out of the squall?"

"Squalls usually sail on starboard tack," Lee explained. "The wind aloft is dominated by coriolis forces and pretty much follows the isobars. But like, at sea level where surface friction slows

wind we sail in. From our point of view, the wind aloft is distorted to the right. That's the air the squall moves in. That's why we get the big shift to the right when the blast of air hits, and why the squall moves like it's on a starboard tack broad reach."

"Makes sense," said Radar, who could hear every word said on deck whenever the wind was up and we were talking in loud voices. "The rain cells usually track to the right of the surface wind direction."

"But why do we get a header just before sailing out of the squall?" asked the standby crew. "Shouldn't there be a lift, if the wind radiates away from the column of sinking air?"

I was afraid he was going to ask that, because I was sure that Lee would be able to answer it, and I was sure it would not be pretty.

"There's an easy explanation," Lee assured us. "The air near the surface can be very unstable at night, and the

SQUALL STRATEGY ARSENAL

- Fast boats: Jibe back and forth to stay in the strongest wind for as long as the squall lasts. Watch for headers that sometimes indicate the boundary of the squall wind. Then exit stage left.
- Slow boats: Jibe to port while in the squall (usually a right-hand shift). The left exit is especially important near dawn and in the morning when the post-squall calm can be big.
- Symmetrical spinnakers and two-pole jibes, for quick and easy jibes with short crew. Jibe early and jibe often.
- Radar for precise squall interceptions. The cheap units work fine.
- Big solar panels, to keep the radar running without extra engine time.
- (optional) A boat that can make VMG downwind equal to at least half the wind speed, up to wind speeds of 30 knots or more.

it down, the wind is distorted outward down the pressure gradient, so like, the wind direction goes across the isobars from high pressure to low. That's the



OYSTER POINT Marina/Park



A full service marina located in South San Francisco with berthing and guest dockage available

For information and pricing call
(650) 952-0808
www.smharbor.com/oysterpoint

in Southern California...



*A First Class Full Service Facility Serving the Entire Pacific Coast
150 Ton & 30 Ton Travelifts*

VENTURA HARBOR BOATYARD

Open 6 Days a Week!
Competitive Rates ~ Professional Staff

For quality and attention to detail you can count on our commitment to your satisfaction.

(805) 654-1433

1415 Spinnaker Drive, Ventura, CA 93001
www.vhby.com

— SQUALL OF THE WILD

cold front of wind ahead of the squall can lift the air up enough to create another rising mass of air. So like, there's a region ahead of the squall that's sucking air up, while the main squall is blowing air down. The system is more like a dipole than a source."

"A dipole?"

"A source-sink combination."

"You lost me completely."

"Okay, how about this: The main squall is a piston going down, pushing air out in all directions. The secondary system is triggered right in front of the squall where the wind is strongest, and it's another piston going up, sucking surface air back up into the sky. The air flows out of the main squall, then curves back around to the rising column, explaining the headers we sometimes get

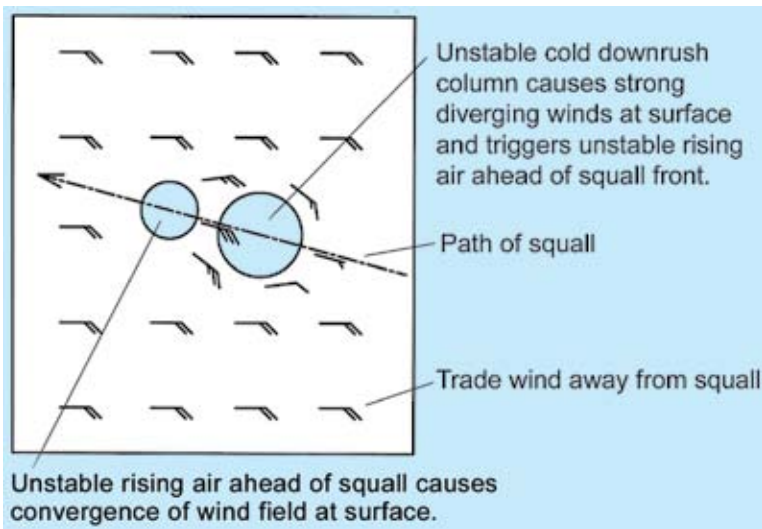

at the boundaries of the system."

We pondered this as the wind continued to drop, and I headed up more and more to maintain speed.

"VMG is pretty bad," I noted. "We're more than 60 degrees off rhumb."

"Gotta get away from the back end of this thing before dawn," Lee advised. "Sail for maximum speed to the south — forget about VMG for now."

It was a close call. We slatted the main once, but the wind came back, the stars came out, and we jibed back to starboard in conditions exactly like what we had been sailing in before the squall hit. The standby crew went below and Radar went back to bed.

Lee woke up the next person in the watch rotation to relieve me.

"Looks like an easy watch," he said as he climbed up the ladder to the cockpit. "Anything exciting happen?"

"Just me and the stars," I yawned. "Steer for best VMG, and wake up Lee if you get lifted more than 10 degrees."

— **max ebb**



Tradewinds Sailing School and Club

1230 Brickyard Cove Rd #100, Point Richmond, CA 94801

Phone: (510) 232 - 7999

Email: staff@tradewindsailing.com

"Sailing is Personal - So is Tradewinds!"

American Sailing Association School

Basic Keelboat (101) - \$575

July 7,8,9
July 16,17,18
July 19,20,26,27
July 21,22,23
July 26,27 & Aug 2,3
July 28,29,30

Basic Coastal Cruising (103) - \$725

July 14,15,16
July 19,20,26,27
July 21,22,23
July 26,27 & Aug 2,3
July 30,31 & Aug !
Aug 2,3,9,10

Bareboat Charter (104) - \$945

Aug 9,16,17
Aug 16,23,24
Aug 27,28,29
Sept 6,13,14
Sept 17,18,19

Don't take our word for it,
see what our students and members have to say!
View school reviews at SailingSchoolReviewer.com

**Our club members enjoy unlimited sailing for
one low monthly rate!**

Summer Special!
**Take \$100 off any
of the above courses!**

www.TradewindsSailing.com

*Expires 7/31/08

THE RACING

In this month's *Racing Sheet* we start with the Singlehanded Sailing Society's **Corinthian Race**. Next up is a recap of a painfully light and long riverine odyssey — the **Delta Ditch Run**. Then we take a look at some Bay Area women who've been putting up good scores in the match racing arena, most recently at the ISAF Grade 1 **BoatU.S. Santa Maria Cup**. Next up, a report from the wildly successful **US Kiteboarding Nationals** in its second year at St. Francis YC. Then it's on to some offshore action — or in some cases, a lack thereof. And don't miss the story of the latest Latitude 38 reader to step up to the **"Beer Can Challenge."**

Corinthian Race

Ross Stein's Corsair 24 Mk II *Origami* made it two in a row for the overall corrected time win in the Singlehanded Sailing Society's Corinthian Race on Saturday, May 31. When it was all said and done, Stein and crew Bill Pace put nearly 30 minutes between them and Steve Carroll's Express 27 *Tule Fog* on corrected time. With consistent breeze in the high teens and a few rare puffs into the low 20s, as well as a couple knots of ebb, the 18-mile course presented all of the 68 starters with interesting tactical choices. After the start off Corinthian YC, the fleet left Little Harding to port and were presented with the first of those — which side of Alcatraz to pass on the way to the Blossom Rock buoy.

For Greg Nelsen aboard his *Azzura* 310 *Outsider* — which finished first in the singlehanded division despite breaking its outhaul sheave — the choice was pretty clear. "I stayed west of Alcatraz to avoid the lee-side wind hole. A doublehanded J/105 that was doing really well with an early spinnaker set got stuck there. . . I was able to set the spinnaker at Alcatraz for the remaining ride to Blossom Rock, which paid huge since I was planing most of the time."

From there the fleet rode the couple-

Blunt. Gordie Nash and Ruth Suzuki's modernized Santana 27, *Arcadia*, rounded out the top three of the 42 starters in the doublehanded fleet, with a couple roundups on the leg. "We crashed in the gybes, but what else is new?" Nash joked. "Of course we only gybed twice so it wasn't too bad. . . It's a lot of boat for two people when it's blowing 19."

With the ebb in full swing, Pt. Blunt was a washing machine, producing some gnarly wipeouts. But the run to Southampton Shoal was the reward as the overcast skies finally began to break. Just as the lee of Alcatraz was a make-or-break obstacle, so was the lee of Angel Island. "After rounding Pt. Blunt, I made sure I dug deep enough to stay clear of the flukey wind in the lee of the island," Nelsen said. "I had strong, steady breeze all the way there and was the

first monohull to round — barely."

The rounding brought with it another crucial-tactical choice — which side of Angel Island to sail around to get back to Little Harding for the starboard rounding and short leg to the finish off Corinthian YC.

We guesstimate that about 60% of the fleet, including *Origami*, chose the Strait as the optimum path around the island. "Raccoon Strait popped us out like a watermelon seed," Stein said. For Nelsen, the trip back to Little Harding started beating up his boat. "The beat back up to Little Harding had some really strong puffs rolling



through and that's where I started to break stuff," he said. "First the mainsail clew strap pulled off, then the outhaul sheave was taking all the load at a bad angle so it twisted and finally broke the fitting and pulled it through the boom."

Steve Hill's Beneteau First 42 *Coyote* finished comfortably in second among the rest of the singlehanders.

Stein and Pace were all smiles at the dock after getting what they said were perfect conditions in a race they feel suits their boat perfectly. "For us, it was just the right amount of wind," Pace said. "Five knots more and we really need another crewmember. Five knots less and we're not planing."

DOUBLEHANDED

MULTIHULL — 1) **Origami**, Corsair 24 Mk II, Ross Stein/Bill Pace; 2) **Peregrine Falcon**, F-27,



Corinthian Race Winners (l-r) — Ross Stein, Bill Pace and Greg Nelsen.

knot ebb up the Cityfront to Blackaller. "We stayed fairly far out on the beat back to Blackaller. . . further out than most" Stein said.

There were more than a few snafus at Blackaller when the kites went up for the run to Southampton Shoal via Pt.



Chris Case pours on the intensity aboard 'Firefly' at the start of the Corinthian Race. It paid — he won the Singlehanded PHRF 100-160 class.

PETER LYONS/WWW.LYONSIMAGING.COM

thian, James R. VanDyke. (2 boats)

PHRF >160 — 1) **Chelonia**, Yankee 30, Ed Ruszel; 2) **Travieso**, Ericson 30+, Daniel Alvarez; 3) **BlueBerry**, Nonsuch 22, John Foster. (5 boats)

NON-SPINNAKER — 1) **Krissy**, Erickson 35-3, Allen Cooper; 2) **Meritime**, C&C 30, Gary Proctor; 3) **Voyager**, Beneteau First 34.5, Alan Barr. (9 boats)

SPORTBOAT — 1) **Hurricane**, Moore 24, Al Germain; 2) **Wetsu**, Express 27, Phil Krasner. (4 boats, 1 RAF)

WYLIECAT 30 — **Nancy**, Pat Broderick. (2 boats, 1 RAF)

SINGLEHANDED OVERALL

1) **Outsider**; 2) **Coyote**; 3) **Nancy 4) Chelonia**; 5) **Krissy**. (26 Boats)

Complete results: www.sfbaysss.org

Delta Ditch Run

In negotiating the raft-up at Richmond YC the morning of the Delta Ditch Run, we stepped on its deck at least 10 times. It was rock-stable, with a rating of 258, and we admit we never once thought, 'maybe it'll be the overall winner.' But Tom and Bill Royall's diminutive Rhodes 19 *big WOW!* won big, taking overall corrected time honors by over 15 minutes.

Much to the chagrin of racers and organizers, the National Weather Service's forecast for the race was right on. With an occasional puff to about 12 knots representing the high for the day, the light air meant finish times after nightfall for the bulk of the 131 boats who started on June 7. But what the breeze lacked in strength, it made up for in consistency over the 67.5-mile course, as it hung around long enough to push the the entire fleet to Stockton.

A result of this weather was that the top four boats all came from the theoretically slowest division — Heavy 3. After *big WOW!*, Stephen Hutchinson's Columbia 5.5 Meter *Seabiscuit* took second overall, and Greg Goodman's Cal 27 *Happyhouka* rounded out the top three. Wayne Wilson's Hunter 30 *Sailavie* was fourth followed by the first ultralight, Caleb Everett's Moore 24 *Tortuga*.

The Ditch Run counts toward the Moore 24 Roadmaster Series. The largest of any of the one-design classes, all 29 finishers ended up in the top-half of the fleet.

Chris Winnard's Holder 20 *Landing Strip* was the second of the lighter-displacement boats overall after *Tortuga*. We encountered *Landing Strip* and her, ahem. . . aviation-inspired name, in the pre-race raft-up also, and were more than a little concerned when the crew broke out bouyancy bags and began to inflate them. . . . but not as alarmed as we were when they took a break to inflate

'*Origami*' blasting to the finish off Corinthian YC in the Singlehanded Sailing Society's Corinthian Race. Skipper Ross Stein and crew Bill Pace won the doublehanded division by nearly 30 minutes.

Bill/Phil Gardner; 3) **Riverdance**, Corsair 24 Mk II, Pierre Chatelin/Peter Kraft. (4 boats)

PHRF <100 — 1) **Jam Session**, J/105, Adam Spiegel/Geoff Papillion; 2) **Pegasus**, J/35, Mark Sykes/Ted Dijmon; 3) **007**, J/105, Bruce Blackie/Mike Hinman. (4 Boats)

PHRF 100-160 — 1) **Arcadia**, Modernized Santana 27, Gordie Nash/Ruth Suzuki; 2) **Carmelita**, Catalina 42, Christian Lewis/Dan Lockwood; 3) **Audacious**, J/29, Scott Christensen/Jonathon Clark. (13 boats)

PHRF >160 — 1) **Sea Witch**, Yankee 30, Bob Boynton/Ansel Boynton; 2) **Grace O' Malley**, Ranger 23, Sean Canavan/Terry O'Sullivan; 3) **Sagitta**, Islander 28, Walter George/Caroline George. (3 Boats)

NON-SPINNAKER — 1) **Shamrock**, C&C 41, Jim Connolly/Richard Keyes; 2) **Joyride**, J/109,

Jim Vickers/Andrew Otewalt; 3) **Arabella**, Alerion Express 28, Harry Allen/Henry Culp. (3 Boats)

SPORTBOAT — 1) **Tule Fog**, Express 27, Steve Carroll/Patrick Lewis; 2) **Sunshine**, Moore 24, Stanly Martin/Joel Truher; 3) **JR**, Moore 24, Richard Korman/Chris Davison. (11 Boats)

WYLIECAT 30 — 1) **Silkye**, John Skinner. (1 boat)

DOUBLEHANDED OVERALL

1) **Origami**; 2) **Tule Fog**; 3) **Arcadia**; 4) **Sunshine**; 5) **JR**. (42 Boats)

SINGLEHANDED

MULTIHULL — 1) **Puppeteer**, Thom's 24, Thomas Davis; 2) **Hecla**, Hammerhead 54, Jeffrey Lebesch; 3) **Triple Play**, F-31, Richard Keller. (3 Boats)

PHRF <100 — 1) **Outsider**, Azzura 310, Greg Nelsen; 2) **Coyote**, Beneteau First 42, Steve Hill; 3) **Alchera**, J/120, Mark Deppe. (3 boats)

PHRF 100-160 — 1) **Firefly**, Dehler 34, Chris Case; 2) **Windward Rhythms**, Cal 39 TM Corin-

LATITUDE/ROB

THE RACING



PETER LYONS/WWW.LYONSIMAGING.COM



PETER LYONS/WWW.LYONSIMAGING.COM



LATTITUDE/ROB

their mascot "Lu Lu the Love Lamb," an anatomically-representational ovis aries. We're not sure whether Lu Lu or the the Kevlar 3Dr sails were more responsible, but *Landing Strip* was fast enough to win the Light 3 Division by a little under three minutes and correct out to sixth overall.

In addition to the usual smattering of groundings, Ed Matson's Laser 28 *Mega Hurts* lost its rig on channel marker 19, and the Moore 24 *Runnin Blues* reportedly snagged it not too long thereafter with the same result.

One grounding resulted in hospital visit for Bob George, who was standing

up at the the helm of the Bilafer family's Henderson 30 *Family Hour* when they hit. Only about a mile from the club, they ran aground with enough force to send George to a rushed meeting with the cockpit sole. Despite his protests that he was fine, the crew convinced him to go get the cut on his head checked out.



LATITUDE/ROB



ERIK SIMONSON/WWW.H2OSHOTS.COM



PETER LYONS/WWW.LYONSIMAGING.COM



PETER LYONS/WWW.LYONSIMAGING.COM

Delta Ditch Walk (clockwise from right) — The Rhodes 19 'big WOW!' blew the fleet away, winning overall by 15 minutes; 'Bullet' soakin' down the Delta; the unofficial entry 'E-ticket' capsized and swamped; Hank Easom's 'Yucca' rolls on; 'Infinity' chases 'Sand Dollar' with a blooper; grounded tiger, hidden mud bank — 'Savage Beauty' in the muck; 'Southern Cross' — the first monohull finisher.

Fourteen staples later, he was released from the hospital and is doing fine.

At the Stockton Sailing Club, the party started late and the band was packing

up by the time many of the crews got to the chow line. The volunteers manning the hoist were still pulling boats like clockwork when we bailed after mid-

night. Judging by the line of trucks and empty trailers waiting to pull up, they were there a lot later than that, keeping things moving.

HEAVY 1 — 1) **Yucca**, 8 Metre, Hank Easom; 2) **Stewball**, Express 37, Bob Harford; 3) **Outsider**, Azzurra 310, Greg Nelsen. (11 boats)

THE RACING

HEAVY 2 — 1) **Arcadia**, Modernized Santana 27, Gordie Nash; 2) **Uno**, Wyliecat 30, Steve Wonner; 3) **Silkye**, Wyliecat 30, John Skinner. (13 boats)

HEAVY 3 — 1) **big WOW!**, Rhodes 19, Tom/Bill Royal; 2) **Seabiscuit**, Columbia 5.5 Metre, Stephen Hutchinson; 3) **Happyhouka**, Cal 27, Greg Goodman. (7 boats)

LIGHT 1 — 1) **Southern Cross**, Melges 32, Don Jesberg; 2) **Sea Saw**, Henderson 30, Tim Cordrey; 3) **Kika**, FT 10m, Marc Pinckney. (10 boats)

LIGHT 2 — 1) **Skiff Sailing Foundation**, 11 Metre One Design, Rufus Sjoberg; 2) **Still Gladiator**, Cheetah 30, Eric Rinkus; 3) **Peregrine**, Hobie 33, Simon Garland. (8 boats)

LIGHT 3 — 1) **Landing Strip**, Holder 20, Chris Winnard; 2) **Racer X**, Santa Cruz 27, Mark Schipper; 3) **Flight Risk**, Thompson 650, Ben Landon. (9 boats)

EXPRESS 27 — 1) **Get Happy!**, Brendan Busch; 2) **Wile E Coyote**, Dan Pruzan; 3) **Eagle**, Ross Groelz. (14 boats)

MELGES 24 — 1) **Average White Boat**, Kent Pierce; 2) **Thumper**, Grant Lepper; 3) **Smokin'**, Kevin Clark. (9 boats)

MOORE 24 — 1) **Tortuga**, Caleb Everett; 2) **Eight Ball**, Scott Easom; 3) **Moore Havoc**, Mark Moore. (30 boats)

WYLIE WABBIT — 1) **Mr. McGregor**, Kim Desenberg; 2) **Kwazy**, Colin Moore; 3) **Szygy**, Simon Winer. (7 boats)

MULTIHULL 1 — 1) **Sling Shot**, Formula 18, Phillip Meredith; 2) **Dionysis**, Hobie Miracle 20, Tim Parsons; 3) **Freedom**, Hobie 20, Mark Lewis. (5 boats)

MULTIHULL 2 — 1) **Serenity**, Catamaran, Michael Ropers; 2) **Three Sigma**, F-27, Christopher Harvey; 3) **Peregrine**, F-27, Bill Gardner. (4 boats)

DITCH CRUISE — 1) **Obstreperous**, Catalina 22SK, Tom Jerry; 2) **E.C. Rider**, Catalina 25, Matthew Loeffler; 3) **No News**, Newport 28, Drew

Myers. (4 boats)

OVERALL — 1) **big WOW!**; 2) **Seabiscuit**; 3) **Happyhouka**; 4) **Sailavie**, Hunter 30, Wayne Wilson; 5) **Tortuga**; 6) **Landing Strip**; 7) **Eight Ball**; 8) **Moore Havoc**; 9) **Penguin**, Moore 24, Matt Dini; 10) **Knot Serious**, Capri 25, Steve Gierke. (131 boats!)

Complete results at: www.stocktonsc.org

BoatU.S. Santa Maria Cup

Two Bay Area-based women's match racing teams posted strong showings at the ISAF Grade 1, BoatU.S. Santa Maria Cup sailed off Annapolis, May 27-31. Liz Baylis and Molly Carapiet met in the weather-shortened petit final of the event with Carapiet winning to take third in the regatta, sailed in J/22s at Eastport YC.

The two teams arrived in Annapolis from two very different sets of circumstances. Baylis' experienced and well-traveled San Francisco Women's Match Racing Team, sailing for the San Francisco YC, was ranked fifth in the world with the event's title to its name back in 2003. Carapiet's team, sailing for St. Francis YC and San Francisco YC, was the upstart amongst a seasoned field.

A five-time collegiate All-American and winner of two national championships at Yale, Carapiet carried some impressive credentials from outside the match racing world, but being younger and relatively unknown, she and her regular 470 crew, Molly Vandemoer of Annapolis, along with former college teammate Emily Hill of Miami and St.



Francis YC's Jen Morgan of Seattle, were spoilers in Annapolis. Ranked 78th in the world coming into the event and having qualified by virtue of their win at the ISAF Grade 3 Sundance Cup a month prior, the team wasn't an obvious choice

YRA SPRING RACE RESULTS

June marked the start of summer and the end of the YRA's spring series. The following results are cumulative scores for ODCA (One Design Classes Association), HDA (Handicap Divisions Association), WBRA (Wooden Boat Racing Association), OYRA (Ocean Yacht Racing Association) and the just-for-fun Party Circuit. For a list of the the second-half season openers, see www.yra.org.

HDA (All classes: 4 races/1 throwout)

99-Raters — 1) **Mintaka 4**, Farr 38, Gerry Brown, 2 points; 2) **White Fang**, Beneteau First 40.7, Mark Howe, 5; 3) **Petard**, Farr 36 (mod.), Keith Buck and Andrew Newell, 6. (14 boats)

SF30 — 1) **Encore**, Wylie Gemini 30, Andy Hall, 2 points; 2) **Topgallant**, Tartan Ten, Jim Lindsey, 4; 3) **Elusive**, Olson 911S, Charles Pick, 5. (5 boats)

DIVISION K (PHRF >102) — 1) **Eclipse**, Hawkfarm, Fred Hoffman, 3 points; 2) **Gandalf**, Santana 35, Ricardo Diola, 3; 3) **Tinker**, Wilderness 21, 7. (9 boats)

ODCA

BENETEAU 36.7 (8 races/3 throwouts) — 1) **Mistral**, Ed Durbin, 5 points; 2) **Ay Caliente**, Aaron Kennedy, 10; 3) **Bufflehead**, Stuart Scott, 11. (5 boats)

ALERION EXPRESS 28 (5r/1t) — 1) **Ditz**, Ralph Morgan, 4 points; 2) **Dream**, Kirk Smith, 9; 3) **Lizbeth**, Michael Land, 13. (6 boats)

SF 180 (6r/1t) — 1) **Harry**, Newport 30-2, Dick Aranoff, 7 points; 2) **Goose**, Catalina 30, D. Michael Kastrop, 7; 3) **Achates**, Newport 30-2, Robert Schock, 16. (7 boats)

EXPRESS 37 (6r/1t) — 1) **Bullet**, Mike Maloney, 7 points; 2) **Elan**, Bill Riess, 10; 3) **Golden Moon**, Bill Bridge/Kame Richards. (6 boats)

ISLANDER 36 (7r/1t) — 1) **Captain Hooke**, Tom and David Newton, 15 points; 2) **Freedom Won**, John Melton, 16; 3) **Tenacious**, Robert Warren/Kris Youngberg, 18. (7 boats)

OLSON 25 (12r/3t) — 1) **Vivace**, Larry Nelson/Frank VanKirk, 10 points; 2) **Synchronicity**, Steve Smith, 19; 3) **Clean Sweep**, Tom Nemeth, 20. (6 boats)

OLSON 30 (2r/1t) — 1) **Hot Betty**, John Scar-

borough, 1 point; 2) **Warpath**, Andrew Zimmerman, 2; 3) **Getting Air**, Patrick Shue, 3. (4 boats)

SANTANA 22 (8r/1t) — 1) **Bonito**, Michael Andrews, 20 points; 2) **Tackful**, Frank Lawler, 20; 3) **Tchoupitoulas**, Giovaccini Buckingham, 22. (10 boats)

WBRA (All classes 10 races/1 throwout)

BIRD — 1) **Polly**, William Stuckey/Dennis Brewer, 23 points; 2) **Oriole**, Dan McLean, 34; 3) **Widgeon**, David Cobb, 37. (5 boats)

FOLKBOAT — 1) **Windanse**, Don Wilson, 15 points; 2) **Josephine**, Eric Kaiser, 21; 3) **Polperro**, Peter Jeal, 30. (13 boats)

IOD — 1) **Bolero**, Richard Pearce, 19 points; 2) **La Paloma**, James Hennefer, 23; 3) **Whitecap**, Henry Hernandez, 27. (6 boats)

KNARR — 1) **Knarrmageddon**, Mike Peterson, 21 points; 2) **Sophie**, Tom Reed, 41; 3) **Larkin**, Jon Perkins, 51. (21 boats)

OYRA

PHRO-1A (6 races/1throwout) — 1) **Serena**, custom Thompson 1150, David Kuettel, 7 points;



JUSTIN MCCABE/WWW.ANNAPOLIS RACING.COM

Bay Area sailor Molly Carapiet keeps seventh-ranked Christelle Philippe close at the BoatU.S. Santa Maria Cup. She beat Philippe in their final round-robin race for the last spot in the semis.

for anyone's shortlist.

"For the sailors who aren't match racing a lot, but are sailing a lot, it may look like they come from nowhere,"

said Baylis, who coached Carapiet this spring. "But, they are sailing a ton, and the boathandling and course awareness is strong. She and her team really im-

pressed at Santa Maria Cup. They sailed a great event."

Baylis' team at the BoatU.S. Santa Maria Cup included Karina Shelton, Pease Glaser and Suzy Leech, and was fresh off a silver medal performance at 2008 Women's Match Racing World Championship in Auckland, New Zealand in April. That medal though, had come without the chance to race for the final. After barely qualifying for the quarterfinals, Baylis and her team, which at that event included Lee Icyda in place of Glaser, clawed their way through the quarterfinals and semifinals to earn a shot against eventual winner Claire Leroy of France. Then the weather stepped in and a complete lack of breeze put an end to the final match. Leroy was determined the winner on a countback of the round robin scores.

In Annapolis, Baylis cruised to a solid second position points-wise in the double round-robin, easily qualifying behind eventual winner and defending champion, Sally Barkow's Team Seven. Carapiet snuck into the fourth and final semi-final spot, punching her ticket only after a do-or-die final round-robin race against Frenchwoman Christelle Philippe, ranked seventh in the world at the time. Tied on points going into that race, she and Phillippe were racing for all the marbles.

"We knew that the race with Christelle was a very important going into it," Carapiet said. "However, we approached it like every other race we sailed. We try to win

2) **Emily Carr**, SC 50, Ray Minehan, 13; 3) **Kokopelli2**, custom SC52, Lani Spund, 13. (6 boats)

PHRO-1 (6r/1t) — 1) **Eclipse**, Express 37, Mark Dowdy, 9 points; 2) **Petard**, Keith Buck/Andrew Newell, 10; 3) **Stray Cat Blues**, J/35, Bill Parks, 19 points. (12 boats)

PHRO-2 (6r/1t) — 1) **Trial Run**, Passport 40, Jack & Kathy Bieda, 16 points; 2) **Ohana**, Beneateau 45f5, Dean Hocking; 3) **No Ka Oi**, Gibsea 42, Phil Mummah, 20. (9 boats)

MORA (6r/1r) — 1) **Always Friday**, Antrim 27, John Liebenberg, 5 points; 2) **Bloom County**, custom Mancebo 31, Anthony Basso, 14; 3) **Sugar Magnolia**, Hunter 29.5, Ward Fulcher, 14. (4 boats)

SHS (Shorthanded, 6r/1t) — 1) **1st Impression**, SC 27, Rick Gio/Jan Grant, 9 points; 2) **Tenacity**, SC 27, Paul Nielsen, 14; 3) **Banditos**, Moore 24, John Kernot, 16. (9 boats)

PARTY CIRCUIT

MULTIHULL (2 races/1 throwout) — 1) **Adrenaline**, D Class cat, Bill Erkelens, 1 point; 2) **Papillon**, F-27, Andrew Scott, 2; 3) **Three Sigma**, F-27, Christopher Harvey, 2. (5 boats)

J/105 (2r/2t) — 1) **Racer X**, Phil Laby/Rich Pipkin/Mary McGrath, 1 point; 2) **Wallop**

Swede, Theresa Bradner, 2; 3) **Miss Demeanor**, Aidan Collins, 2. (4 boats)

EXPRESS 27 (3r/1t) — 1) **Strega**, Larry Levit, 1 point; 2) **Freaks On a Leash**, Scott Parker, 1; 3) **Archimedes**, Joe Balderrama, 2. (3 boats)

CRUISING CATS (2r/1t) — 1) **Endless Summer**, Cruising Cat, Steve May, 1 point; 2) **Serenity**, Seawind 1160, Michael Ropers, 1; 3) **RotKat**, Cruising Cat, Arjan Bok, 2. (3 boats)

SF 198+ (2r/1t) — 1) **Star Ranger**, Ranger 26, Simon James, 1 point; 2) **Latin Lass**, Catalina 27, William Chapman, 2; 3) **Madness**, Sprinta Sport 23, Dusty Hayes, 3. (5 boats)

IOR WARHORSE (2r/1t) — 1) **Infinity**, custom Holland 47, Gary Gebhard, 1 point. (1 boat)

NON-SPINNAKER (2r/1t) — 1) **Drama**, Beneateau 440 Oceanis, Robert Irby, 1 point; 2) **Blueberry**, Nonsuch 22, John Foster, 1; 3) **Lassie**, Pearson 28, Michael Farrell, 2. (3 boats)

DIVISION G (PHRF <66, 2r/1t) — 1) **Splash**, Beneteau 42s7, Ray Handyside, 1 point; 2) **Kika**, Flying Tiger, Raffaele Sena/Marc Pinkey, 1; 3) **Jeannette**, custom Frers 40 1T, Henry King, 2. (14 boats)

DIVISION H (PHRF 69-93; 2r/1t) — 1) **Crazy Diamond**, J/109, Liga & Soren Hoy, 1 point; 2) **Mintaka 4**, Farr 38, Gerry Brown, 1; 3) **Max**, Ant-

rim 27, Ryan Richard, 2. (15 boats)

DIVISION J (PHRF 86-117; 2r/1t) — 1) **No-via**, Cal 39, David DeMeter/Dick Baker, 1 point; 2) **For Pete's Sake**, Ultimate 24, Peter Cook, 1; 3) **Baleineau**, Ericson 34, Charles Brochard, 2. (10 boats)

DIVISION K (PHRF 120-159; 2r/1t) — 1) **Chimera**, Little Harbor 47, C. Grant Miller, 1 point; 2) **Blue Pearl**, Hunter 41, John Dahle, 2; 3) **1st Impression**, SC 27, Rick Gio/Jan Grant, 2. (10 boats)

DIVISION M (PHRF 162-195, 2r/1t) — 1) **Gypsy Lady**, Cal 34, Val Clayton, 1 point; 2) **Chesapeake**, Merit 25, Jim Fair, 1; 2) **Don Whan**, Santana 28, Don Kunstler, 2. (10 boats)

DIVISION D (SF 30, 2r/t) — 1) **Plan B**, J/29, Brett DeWire/Rob Stubblefield, 1 point; 2) **Lazy Lightning**, Tartan Ten, Tim McDonald, 1; 2) **Topgallant**, Tartan Ten, Jim Lindsey, 2. (8 boats)

SINGLEHANDED (2r/1t) — 1) **Speed Racer**, Merit 25, Teresa Scarpulla, 1 point. (1 boat)

PC SF-180 (2/1t) — 1) **Huge**, Catalina 30, Russell Houlston/William Woodruff, 1 point; 2) **Windsome Wench**, Newport 30, Robbie Murphree, 1; 3) **Starkite**, Catalina 30, Laurie Miller, 2. (4 boats).

Complete results: www.yra.org

THE RACING

each one we sail. Nevertheless, we were ecstatic when we won."

In the first semifinal match-up with Barkow, Carapiet's team fell 3-1 which set up a petit final against Baylis, who'd lost 3-1 to Frenchwoman Anne-Claire Le Berre in the other semifinal match. Carapiet drew first blood before the weather stepped in, dispensing to Baylis' team a fate similar to the one that befell the crew in Auckland. After the first race, a storm rolled through, leaving a greasy calm, a premature ending, and a frustrated race committee in its wake.

"The petit finals were supposed to be best of three," Carapiet said. "A huge storm hit Annapolis right before we were beginning the second race. There was rain, hail, thunder, lightning, and huge winds."

"You would always prefer to sail all of the matches in any competition," Baylis said. "But we do compete in a sport that is pretty much controlled by nature. . . . I had no desire to stay out on the water once the lightning started."

In the only race completed for the finals match, Barkow beat Le Berre for



Jon Modica fully powered-up at the US Kiteboarding Nationals, now in its second year.

her third win at the event. For Carapiet — sailing in only her second regatta at the helm of a keelboat, in her first ISAF Grade 1 match racing event — the result

was as gratifying as the company.

"We were pleased with our performance," she said. "I was especially happy with our teamwork. Although I've sailed with each of my teammates individually, this was our first time together as a team. They made me look good."

As far as her future plans go, Carapiet seems to have caught the match racing bug, which will have to be satisfied between the events she's pursuing with Vandemoer for their work-up to the trials for the 2012 Olympics in the 470.

"I'd like to continue match racing," she said. "In the near future I will be crewing for Liz at the Mayor's Cup in Long Beach and the Lysekil Women's Match Race in Lysekil, Sweden."

For Baylis, the fact she'd coached Carapiet in the spring was not lost on her teammates: "A few in my team ribbed me a little about maybe teaching Molly too much! But Molly is a great sailor and she took on the challenge of learning to match race with a lot of enthusiasm."

Final — Sally Barkow (USA) d. Anne-Claire

ANDREW KARCIE

SOUTH BEACH YACHT CLUB
& BENICIA YACHT CLUB

are proud to present the 20th Annual

JAZZ CUP

Saturday, August 30, 2008

Best in Downwind Racing

SAN FRANCISCO
TO BENICIA

For entry forms &
information, see

www.southbeachyachtclub.org

or call Sherry Nash at

(650) 552-9260



McGinnis Insurance

Since 1972

Knowledge ♯ Commitment
Reliability ♯ Service



Large and small, we do them all!

Call us at: **800-486-4008**

meginnsins@aol.com

License #0570469

Le Berre (FRA) 1-0*
 Petit Final — **Molly Carapiet** (USA) d. **Liz Baylis** (USA) 1-0*

**curtailed by lack of breeze*

US Kiteboarding Nationals

In front of a crowd of about 300 spectators lining the Crissy Field seawall, Damien LeRoy of Naples, Florida, put the finishing touches on a consistent week at the US Kiteboarding National Championships hosted by St. Francis YC June 10-14, scoring three seconds in the event's final three races. Despite only winning 5 of his 15 races between the qualifying and championship rounds, LeRoy's two throwouts for the week were only a second and third, which proved good enough for a 4-point win over Colima, Mexico's Sean Farley. The top local finisher was Anthony Chavez in fifth.

If you don't follow kiting and had never heard of Farley, LeRoy or Chavez, you still might recognize one name in the field: Santa Cruz's Mo Hart.

Hart, who was born and raised in Maine but has lived in Northern

California since the late '90s, did well enough at the event to qualify for the championship races ending up in 30th overall. The name might sound familiar because Hart was a member of the US Sailing's Olympic team for the run-up to the trials for Athens in 2004. He spent four years training with Team Pegasus, and three or four months per year during that time were spent with the team in Hawaii, where he picked up kiting.

"I would go over to Kailua at sunrise and get some time in during the morn-



ANDREW KARCIE

Second Place Sean Farley (r) congratulates winner Damien LeRoy after a race at the USKNA.

ings before the day would start," he said about his first forays with the kite around 2000. "It was fun to learn in warmer water and I kept doing it when I would come back to California."

Following his run at the Olympic tri-

24th
 Annual



Come to
 the Party!

THE BAY VIEW BOAT CLUB AND THE ISLANDER BAHAMA FLEET
 invite all

'60s & '70s Vintage Fiberglass Sailboats

to the San Francisco

PLASTIC
 CLASSIC
 REGATTA

and

Concours d'Elegance

Including Laser Masters
 Pacific Coast Championship 2008

Saturday, July 19

at the Bay View Boat Club and the waters of Pier 54.

For more information:

Call Peter McCool, Race Committee Chair, (415) 864-4334

Bay View Boat Club, 489 Terry Francois Blvd., San Francisco, CA 94107

TROPHIES TO PRETTIEST BOAT AND FASTEST OVERALL

10 a.m. UNTIL DARK • RACE STARTS AT 1 p.m. • TROPHY PRESENTATION AT 7 p.m.

THE RACING

als, Hart took time off from sailing to go to school and start an IT business. In fact he's only recently started sailing again with Peter and Kristen Lane's Tiburon-based Brickhouse team. But during that layoff he didn't put the kite down, and when this event came along he jumped right in the fray.

"John Craig ran an awesome event," Hart said about the event's PRO. "Working us around the ships and ferries must have added a few gray hairs to his head. The neat thing is that this is all being written as they go along. They've never done this before for this many kites, so it's cool to see how it all came together."

Course racing is newer to kiteboarding than kiteboarding is to wind-powered watersports, and this was the St. Francis YC's second running of the event. If the 40-kites out of 70 entries are any indication, it's here to stay. But a dustup over control of who should administer the sport is looming, and ISAF has yet to recognize it as a discipline.

"Obviously someone needs to organize it," Hart said, speaking to the polemic of



'Criminal Mischief' was a casualty of a slow Spinnaker Cup. Just 16 of the 55 starters finished.

the day for course-racing kiteboarders. "I don't think it matters who, as long as you can keep it friendly for the kites. Basically, whoever it is needs to listen to what the kites want. Sponsors can make it good, but that won't ever happen if going with ISAF means you can't put

logos on kites or you can only put them on say, 25% of the wingtips. I guess the question is, 'are the formula windsurfers happy they went to ISAF?' That history would probably repeat itself."

Hart acknowledged that there are probably more than a few answers to that last question, but in the meantime, he's just trying to recuperate from the long week of racing on the Cityfront, where spectators crowded the beach each day of the event in a manner sailboat racing seems hard-pressed to do.

"I'll tell you one thing," he said. "It made the Olympic trials look easy. My legs were torched. Those were long courses."

Now that comparison might not resonate with you yet, as we haven't told you which class he was sailing in the trials... The Finn!

USKNA — 1) **Damien LeRoy**; 2) **Sean Farley**; 3) **Sky Solbach**; 4) **John Modica**; 5) **Anthony Chavez**. (40 kites)

Complete results at: www.stfyc.org

ERIK SIMONSON/WWW.H2OSHOTS.COM

Wright Way designs

Custom Yacht Interiors

PROFESSIONAL DESIGN SERVICES INCLUDE CUSTOM

- carpeting
- cushions
- designer fabrics
- draperies
- linens
- upholstery



Deborah Wright
510.908.3939

2900 Main Street #67, Alameda, CA 94501
wrightwaydesigns@hotmail.com
 Check out our new web site:
www.wrightwaydesigns.com

GLEN COVE MARINA

Come Visit Our Historic Lighthouse and New Cafe

SUMMER KICKOFF EVENT

JULY 19TH

with Music, BBQ, Arts and Crafts Show, Winetasting and More!

Now Available:
Two 55-foot uncovered slips available now!



GLEN COVE MARINA 707-552-3236

2000 Glen Cove Road, Vallejo, CA 94591

www.glencovemarina.net • glencovemarina@gmail.com

Spinnaker Cup

After a few days of wind in the 40s out of the northwest, May 23's Spinnaker Cup was looking promising for a typical 90-mile downwind blast from San Francisco YC to Monterey. But a low-pressure system that brought a little drizzle to parts of Northern California had other ideas, and the 57 starters in five divisions had to contend with a weak southerly flow that got progressively lighter as the fleet worked its way down the coast. Only 16 boats persevered all the way to the finish at Monterey Peninsula YC.

The only finisher in the Doublehanded division was Paul Nielsen's aptly named SC 27 *Tenacity*. Dick Watts' TP 52 *Flash* corrected out over the only other finisher in PHRO 1A, Dave Kuettel's Thompson 1150 *Serena*. PHRO 1 had the most finishers with Bill Parks' J/35 *Stray Cat Blues* beating the other 10 to win on corrected time. In PHRO 2, Steve Waterloo's Cal 40 *Shaman* was the lone finisher, and Steve Carroll's Express 27 *Tule Fog* took the MORA division.

DOUBLEHANDED — 1) *Tenacity*, SC 27, Paul

Nielsen. (9 starters)

PHRO 1A — 1) *Flash*, TP 52, Dick Watts; 2) *Serena*, T 1150, Dave Kuettel. (9 starters)

PHRO 1 — 1) *Stray Cat Blues*, J/35, Bill Parks; 2) *White Dove*, Beneteau 40.7, Mike Garl; 3) *Tiki Blue*, custom 42, Gary Troxel. (17 starters, 11 finishers)

PHRO 2 — 1) *Shaman*, Cal 40, Steve Waterloo. (7 starters)

MORA — 1) *Tule Fog*, Express 27, Steve Carroll; 2) *Sea Saw*, Henderson 30, Tim Cordrey. (6 starters)

In the Wake of Drake

As with several ocean races early in the year, OYRA's June 7-8 Drakes Bay



PETER LYONS/WWW.LYONSIMAGING.COM

That's more like it — the only coastal race since the DHF with breeze this year was Drake's Bay.

weekend was a windy one.

"Each boat earned their way to Drakes Bay," says Phil Mummah of the Gibsea 42 *No Ka Oi*. The 14 participants in four divisions battled upwind through 25-

COMING SOON - FT 7.5M

www.flyingtigerboats.com

FAST, FUN, AFFORDABLE

THE RACING

35 knots on Saturday, then spent the night at anchor — protected from the big swells but still buffeted by big breeze. By Sunday morning, they had 'earned' their reward: racing downwind back to the Bay in the same conditions.

Speaking of earning, Mummah and crew clinched a well-deserved first in PHRO-2 on the uphill half of the weekend, then got the gun in the five-boat class on the run home Sunday, correcting out to second. (The days are scored separately.) They traded their first and second with Jack and Diane Bieda on the well-sailed Passport 40 *Trial Run*.

And, of course, the racers once again gained a renewed appreciation of the spectacular sailing experience to be had outside the Bay. "It was beautiful watching the boats come through the Gate on a flood tide with spinnakers flying in 20+ knots," said Mummah.

SATURDAY, 6/7

PHRO-1A — No Starters

PHRO-1 — 1) **Eclipse**, Express 37, Mark Dowdy; 2) **Petard**, Farr 36 (modified), Keith Buck/Andy Newell; 3) **Stray Cat Blues**, J/35, Bill Parks.



LYNN BUCHANAN

Tom Page's "Late Start" leads Gregg Rohde's "Criosaith" at the Go For The Gold Regatta.

(4 boats)

PHRO-2 — 1) **No Ka Oi**, Gibsea 42, Phil Mummah; 2) **Trial Run**, Passport 40, Jack & Diane Bieda; 3) **Ohana**, Beneteau 45f5. (5 boats)

MORA — 1) **Always Friday**, Antrim 27, John Liebenberg. (1 boat)

SHORTHANDED — 1) **Melange**, Express 37, Jim and Petra Reed; 2) **Tenacity**, SC 27, Paul Nielsen; 3) **1st Impression**, SC 27, Rick Gio and

Jan Grant. (7 boats)

SUNDAY, 6/8

PHRO-1A — No Starters

PHRO-1 — 1) **Petard**, Farr 36 (modified), Keith Buck/Andy Newell; 2) **Eclipse**, Express 37, Mark Dowdy; 3) **Stray Cat Blues**, J/35, Bill Parks. (4 boats)

PHRO-2 — 1) **Trial Run**, Passport 40, Jack and Diane Bieda; 2) **No Ka Oi**, Gibsea 42, Phil Mummah; 3) **Galaxsea**, Custom Nauticat 43.5, Daniel Willey. (5 boats)

MORA — 1) **Always Friday**, Antrim 27, John Liebenberg. (1 boat)

SHORTHANDED — 1) **1st Impression**, SC 27, Rick Gio & Jan Grant; 2) **Le Flying Fish**, Moore 24, JP Sirey & Stephane Plihon; 3) **Tenacity**, SC 27, Paul Nielsen. (3 boats)

Complete results at: www.yra.org

Go For The Gold Regatta

Over 50 boats and 100 sailors descended on Scotts Flat Lake, northeast of Nevada City on June 7-8 for five races in in wind from 5- 20-knots.

"Winds came over the dam just like clockwork," said organizer Jerry Lewis from the Gold Country YC.

There were eight divisions, including

Last Year, More Than 100,000 Boaters Needed Assistance.



You may think you'll never need a tow but odds are good that you will at some point—just ask the BoatU.S. Members who were towed last year. That's why it pays to have Unlimited Towing from BoatU.S. With the average price of a tow around \$600— it's better to pay a little now rather than a lot later.

Unlimited Towing from BoatU.S. includes:

- ✓ On-the-water towing, soft ungroundings, jump starts & fuel delivery
- ✓ Applies to all recreational boats you own, borrow or charter
- ✓ 24/7 dispatch and assistance
- ✓ No claim made on your hull insurance

To join BoatU.S., call **800-888-4869**
or visit **BoatUS.com**

VESSEL ASSIST[®]
Towing You Can Trust From BoatU.S.

Look For the RED Boats of Vessel Assist

*Details of service provided and exclusions can be found online at BoatUS.com/towing or by calling.

multihull, Ultimate 20s, Catalina 22s, Lasers and Sunfish.

OPEN MULTIHULL — 1) **1603**, Nacra, Mike Peavey, 6 points; 2) **Rhino**, Nacra, Peter Schmalzer, 11; 3) **14**, Nacra, Jason Smith, 11. (4 boats)

ULTIMATE 20 — 1) **Cinderella Story**, John Andrew, 7 points; 2) **Layla**, Trish Sudell/Tom Burd, 10; 3) **UFO**, Trent & Kim Watkins, 27. (6 boats)

OPEN KEEL — 1) **Kudzu**, Capri 22, Jerry Lewis, 10 points; 2) **Bear**, Santana 20, Gary Dowd, 10; 3) **J/22**, Scott Mack, 16. (5 boats)

CATALINA 22 — 1) **Dumbo**, David Torrisi, 11 points; 2) **Sirius**, Michael Rayfuse, 12; 3) **Late Start**, tom Page, 17. (8 boats)

OPEN CENTERBOARD A — 1) **338**, Megabyte, Charles Witcher, 11 points; 2) **Heartbeat**, Windmill, Alan Taylor, 16; 3) **2095**, C-15, Ryan Schofield, 17.5. (8 boats)

OPEN CENTERBOARD B — 1) **307**, DS, Steve Lowry, 7 points; 2) **11745**, El Toro, Walter Andrews, 12; 3) **Windy Britches**, DS, Wade Behling, 14. (7 boats)

SUNFISH — 1) **57707**, Roy Jordan, 9 points; 2) **See Ya**, Byron Jonk, 10; 3) **31191**, Bob Cronin, 12. (7 boats)

LASER — 1) **Dan Ouellet**, 6 points; 2) **Richard Leland**, 15; 3) **Tony Dahlman**, 15. (7 boats)

Coastal Cup

The dire weather forecasts proved horribly correct for the 21-boat fleet sailing Encinal YC's Coastal Cup, which started Jun 12. Nearly 71 hours later the last of only three finishers, Shaun Hagerman's J/105 *Double Trouble*, crossed the finish line off the Santa Barbara YC. Bill Turpin's R/P 77 *Akela* was first on

both elapsed and corrected time, completing the 277-mile course in a little over 48 hours at an average speed of 5.7 knots. The Fox 44 *Ocelot* was the only other boat to finish. Two boats hung in the whole way and barely missed the cut-



ERIK SIMONSON/WWW.H2OSHOTS.COM

HDA, ODCA and WBRA fleets all got into the swing of Summer Sailstice 2008. Upwards of 125 dinghies from Lasers and V-15s to Optis raced in, or near, Clipper Cove. See this month's 'Sightings' for more on the event.

off, Simon Garland's Hobie 33 *Peregrine* and Jim Gibbs' Express 27 *Moonlight*.

Encinal YC is considering reviving Catalina as the destination next year, in a return to the race's roots.

CLASS A — 1) **Akela**, R/P 77, Bill Turpin; 2) **Ocelot**, Fox 44, Flannigan/Nelsen. (2 finishers)



LOCATION!

(We're SO convenient and easily accessible from all over the greater Bay Area!)

LOCATION!

(No gimmicks, no hidden fees – 20-plus years of boating expertise at your service!)

LOCATION!

(We're full-service –and your next project is definitely our priority!)

SAN FRANCISCO BOAT WORKS

835 Terry A. François St., San Francisco, CA 94158

(415) 626-3275 Fax (415) 626-9172

www.sfboatworks.com sfboatworks@yahoo.com

Be our guest for lunch at the historic Ramp Restaurant*

*Some restrictions apply



THE RACING

CLASS C — 1) **Double Trouble**, J/105 Shaun Hagerman. (1 finisher)
 OVERALL — 1) **Akela**; 2) **Double Trouble**; 3) **Ocelot**. (3 finishers, 21 starters)

Beer Can Challenge Winner

Ladies and gentlemen — we have a winner! Larry Riley is the latest sailor to join an elite few iron men (and women) who have answered *Latitude 38's* grueling Beer Can Challenge — participate in one beer can race every day for a week. It sounds easy. So did curing the common cold.

What's even more impressive: Riley did it with his own boat, the *Diva 38 Arowana* — and even most of his regular crew. Here's his account:

Monday (Bay View Boat Club) — Since we'd never sailed here before I figured the best strategy was to follow the leaders. However, being the lowest rated boat in the race, it quickly became clear we were the leaders. Dang! Fortunately, my crew managed to find all the proper marks and get us across the finish as though we knew what we were doing. What a lovely sail — flat water, gorgeous light and nice



COURTESY, ENCINAL YC

'Flash' and 'Lightning', casualties of a terminally-slow Coastal Cup — three boats finished.

wind, even warm. Everyone wanted to stay for dinner but as the poet said, there were miles to go before we slept. Sailed partway back to our berth at RYC and powered the rest of the way.

Tuesday (Sausalito YC) — We'd done many of these so we knew that escaping the cove is a big part of the race. Not this

time. The start was just north of Little Harding, right into the teeth of it. Where did all this wind come from?

The weather mark was scary. Had a near-death experience with a over-zealous newbie but lived to tell the tale. The wind moderated after that, the rest of the race was your standard off-the-shelf Sausalito evening of unsurpassed beauty. Probably the best place in the world for a beer can race.

Wednesday (Richmond YC) — Richmond is the most relaxed and fun of all the beer can series. And Eric Arens's 'rating system' is second to none. For example, in one race all the green-hulled boats received a three-minute/mile handicap. I won another one because we had the most kids on board.

This Wednesday night it was blowing again. So there we were, pounding through a pack of nasty, square waves and mixed up as to where we were supposed to go. Most of the other boats were clearly committed to one mark, but the Commodore over there was rounding that red channel marker. We decided to



VALLEJO MARINA

Gateway to the Bay & Delta



*We love making new friends
and spoiling them!*

- Competitive Rates!
- Ample Guest Dock
- Full Service Boat Yard and Chandlery
- 2 Restaurants for Breakfast, Lunch, Cocktails, Dinner
- Covered and Open Berths



**48-ft.
BERTHS
NOW
AVAILABLE**





*Join us for those
warm summer nights!*

- One hour from Sacramento
- Only Three hours from Reno
- Easy access to San Francisco Bay and the Delta

**(707)
648-4370**

Fax 707-648-4660
42 Harbor Way
Vallejo, CA 94590
www.ci.vallejo.ca.us

follow him and, as it turns out, he (and we) guessed right. On the way back to the finish we hit 12 knots with no chute up — on both the knotmeter and GPS. Better get both of 'em fixed.

Thursday (Benicia YC) — I always forget just how far away Benicia is. We got everything packed and ready Wednesday night and on Thursday headed out before noon. There's nothing but ebb the whole way, but we make it with an hour to spare until the start.

Once again, lots of wind at the start. I'm sensing a trend here. We had two relatively inexperienced crew aboard so sailed non-spinnaker. This time we stuck around for dinner at the club — mostly because they were having a breast cancer fundraiser that featured a member-cooked spaghetti feed. A great cause, for sure, but so good that we'd come back just for the food. Thank you Benicia YC for the warm welcome.

Friday (Corinthian YC) — Old home week. CYC's Beer Can Series is about as good as it gets. I did these for three summers on the Wyliecat 30 *Silkye*, and two

on *Arowana*. Too busy last year.

After a week of windy evenings, this one looked mellow. Very mellow. Who hit the off-button for the wind machine? We tucked in by Belvedere Point for a while, but as the sun dropped behind Tamalpais, the wind died completely. Hoped for a mutiny, but the crew won't hear of it. So I have to do it myself. Engine on, race abandoned, no finishers in our division. Figure I'm still good for the Beer Can Challenge since the rules only say 'participate in', not 'complete' every race.

Helping out at various times during the week were crewmembers and friends Amy Oakland, David Oakland, Charlie Brochard, Daniele Melhan, Jeff Nelson, Attila Plasch, Michael Ruiz, Martha Mc-



COURTESY AROWANA

Why is Larry Riley smiling? Because he just conquered the 'Beer Can Challenge' — five beer can races in as many days. Lucky guy!

Coy, Lydia Ruiz, Erik Menzel, Jill Keimach, Kim Benninghoven and my boat partner, Ken Finney. Thanks folks!"

In recognition of valor above and beyond the call of common sense, we hereby award Larry a *Latitude 38* T-shirt and 15 minutes of fame — which you've just read.

The North Bay's complete marine service facility:

- Complete chandlery
- 40-ton haulout service
- Engine & drive service
- Trailer boat/outdrive service & repair
- Bottom paint
- Finish paint
- Fiberglass repair
- Marine electrical



Don't Pass Us By...

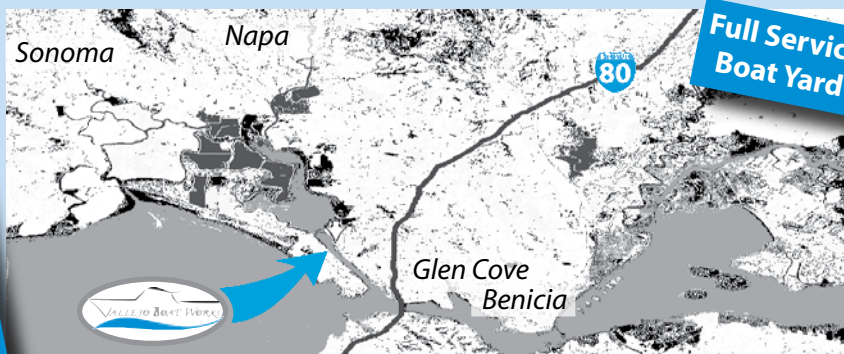

See us for your service needs on the way up to the Delta!

Why Haul Your Boat Down to the Central Bay?

Factory Authorized Dealer

"If it's broken, we fix it."



www.vallejoboatworks.com

1 Harbor Way, Vallejo
(adjacent to the Vallejo Marina)

(707) 554-2813

With reports this month on **The Challenge of Addressing the Eco-Impacts of Chartering** and a frequent charterer's **Cat Cruise Through the Sea of Cortez**.

The Greening of the Charter Industry: Taking Sustainable Steps

Many years ago the British Virgin Islands government took the laudable step of declaring the entire underwater realm of their country to be a marine preserve. That decision was not only a remarkably progressive step at the time, but also a completely logical one, in that tourism — primarily waterborne tourism — is the mainstay of the BVI economy.

That action has gone a long way toward preserving the territory's distinction as the most popular yacht chartering destination in the world — and a top scuba diving venue. However, while sailors and divers are restricted from removing anything from the water, including shells and coral fragments, it has struck many visitors as odd, if not crazy, that they are allowed to dump human waste directly into those same waters. The problem is that pumpout stations are few and far between in the BVI and throughout the Eastern Caribbean. A similar dilemma exists at many other prime chartering venues throughout the world.

Vacationers who marvel at the beauty of tropical fish and coral, and the clarity of the water, are often stunned by the fact that they are expected to pump heads directly overboard — despite the fact that most charter boats are manufactured with holding tanks. Scientists might point out, however, that the constant flushing action of ocean currents greatly diminishes any negative effects of thousands of boaters pumping out,

At busy Roche Harbor in the San Juan Islands the 'Phecal Phreak' "takes crap from anyone." Many charter boats use this service.



LATITUDE / ANDY

arguing that such waters are perfectly safe to swim in. Nevertheless, it's the mere *idea* of it that bothers some visitors. Over the years we've received a number of letters to the editor stating startled disbelief that this practice is allowed to continue in the BVI and elsewhere. Unfortunately, implementing a solution isn't nearly as simple as you might think, because in most Caribbean nations, and elsewhere in the developing world, most waterside facilities are not connected to a central sewage treatment system. Even in the neighboring U.S. Virgin Islands, where, under U.S. law, pumping out into inshore waters is a serious offense, such rules are largely unenforceable due to the lack of pumpout infrastructure.

With that lengthy introduction, we're happy to point out that Sunsail and The Moorings have recently taken progressive steps to address the pumpout problem, as well as other environmentally sensitive issues. With any luck, their actions will build substantial momentum toward the 'greening' of the entire charter indus-



LATITUDE / ANDY

The promise of pristine diving conditions is key to the success of many tourism-based economies.

try.

Because both Sunsail and The Moorings are owned by the same parent company these days — Tui Marine — both charter opera-



LATITUDE / ANDY

tions now share the same BVI base at Tortola's Wickham's Cay II, where a number of eco-friendly steps have recently been taken. As part of the new Crystal Green program, the marina's holding tank pumpout facilities are now linked to Road Town's sewage system. In addition, with the construction of a new seawall which protects the marina, an innovative system has been developed to increase seawater circulation within the marina area. Special pumps will augment the natural circulation of water from outside the seawall deep into the inner harbor. As it moves through the pumps, this water will be filtered to enhance water quality and circulation.

As reported earlier in these pages, The Moorings has also been manufacturing a new line of '4300' charter cats propelled by electric motors that are powered by highly efficient diesel generators. The expectation is that these, and future models, will substantially reduce the company's 'carbon footprint'.

Another positive step is the use of innovative antifouling paints which are said to release roughly half the toxins of traditional bottom paint. The use of LED flashlights and biodegradable soaps,



Few things in life are more satisfying than snorkeling in clear tropical waters, such as Raiatea's tranquil lagoon. Environmental awareness will help preserve such prime venues.

both aboard boats and in company laundry facilities, are other small steps that will ultimately make a positive impact.

Being the two largest charter outfits in the world, you might say it's easier for Sunsail and The Moorings to adopt such practices than it would be for a small 'Mom and Pop' operation. While that may be true, the 'big boys' are also in an ideal position to set an environmental standard which smaller companies can strive to match. We invite you to encourage the smaller companies you work with to do all they can to make such changes universal within the industry. And you can tell them that the costs of making progressive changes can be offset by the positive PR value they'll earn.

What else can be done to insure the preservation of the world's prime sailing destinations? If you have what you think are worthwhile suggestions, don't be afraid to voice them — respectfully and diplomatically, of course — to tourist boards and other government agencies. Competition for tourist dollars is intense

throughout the world these days — especially now, with leisure travel slowing due to airline fuel costs. So savvy officials would be wise to climb aboard the 'green' bandwagon.

While we're on the subject, we'll remind you that, as travelers, it's important that we always show great respect for the cultures and physical environments we visit. Part of doing that is setting an exemplary example of 'environmental stewardship' by never throwing trash overboard, preserving marine ecosystems and, if you must pump out away from a shore facility, do so in deep offshore waters.

We think you'll like our final tip: The best way we know of to de-

crease your 'footprint' while chartering is simply to resist the temptation to kick on the diesel, and sail from point to point whenever possible!

— latitude / andy

In the British Virgins, the rocky grottos called The Baths are a 'must-see', but increased tourism has had an impact.



LATITUDE / ANDY

WORLD



ALL PHOTOS ART HARTIGER

The Sea of Cortez is unlike any other charter venue. There are few shoreside amenities, but plenty of tranquil anchorages.

Cruising the Sea of Cortez: A Million Miles from the Mainstream

As repeatedly mentioned in *Latitude*, the allure of Baja is powerful. Our sailing mate, Donna, is a Baja expert — although her knowledge was mostly land-oriented until this trip — and she relentlessly enticed us with stories about blue-footed boobies, rattlesnakes, strange

Mexico cruising accounts in *Latitude* for years, as well as stories about the Ha-Ha, I think I am beginning to understand what everyone is raving about. We were not disappointed by our experience in the Sea of Cortez, and have vowed to return. As one member of the crew said, "We left a piece of ourselves down there."

Our crew of eight consisted of Donna, our spiritual leader; Boone, boat counselor-at-law; Geoff, chief of lifeguard services; Virginia, head chef superior;

cacti and delicious tequila recipes. We eventually gave in and chartered a 40-ft cat from The Moorings called *Firecat*.

As trite as it may sound, our trip in April really was amazing. Having read

Nathan, chief of hijinks and gymnastics; Doctor Amy; Roberto, chief angler and mixologist; and yours truly, 'El Capitan'.

When we arrived at the La Paz airport with four cases of California wine, we got our first lesson in negotiation, Mexican-style.

Okay, perhaps we should have paid attention to the customs and duty rules. But I've checked enough wine through foreign ports to know that customs rules are sporadically enforced. Not this time. We were escorted to another room, where we had a thirty-minute negotiation regarding the value of the wine and the overall cost. The customs official demanded 75% duty, except for four bottles allowed per person. After some spirited discussions in Spanglish, and much laughter, our chief of lifeguard services negotiated the price to be 75% of the "value" of bottles attributable to seven adult passengers. We may have been gouged, but we had fun. Next time we might smuggle things in a bit differently.

Tortola BVI
Belize
The Grenadines

UNIQUELY
TMM

Marisa
TMM Belize

Most charter companies offer blue water & palm trees, but it takes the personalized care of people like Marisa to make your vacation a success.

Like Marisa, everyone at TMM is committed to your complete satisfaction. Our specialized three-location operation offers large company quality with small company service. A combination that is uniquely TMM.

TMM
Yacht Charters
Since 1979

catamarans • monohulls
motor yachts
ownership programs

Real People. Real Sailing. Real Fun.

Sail Cats | Power Cats
Monohulls | Trawlers
Bareboat | Skippered

Real Choices.

Choose CYOA and become part of the family. We've been providing beautifully maintained yachts, personal service and sensible prices to sailors since 1980.

1-800-944-2962
info@cyoacharters.com
www.cyoacharters.com
St. Thomas USVI 00802

CYOA
YACHT CHARTERS

OF CHARTERING

I always find the gigantic X-Ray machines in the luggage area at smaller foreign airports to be very interesting. If you put your luggage at the front of the machine, it is dutifully passed through the machine. If you don't, well, that's ok too. Just walk on by and smile.

We taxied to Hotel Los Arcos, and loved it. After settling in, we strolled out along the *malecón* for dinner and exploration. Virginia had researched the local restaurants and insisted that we eat at Las Tres Virgenes. I have to say the barbecued octopus was phenomenal.

Along the way, our chief of lifeguard services stopped at a *farmacia* to purchase antibiotics in case of an emergency, and to round out the boat's first aid kit — no prescriptions required. Donna made us stop at Hotel Yeneka, where the monkey she fondly remembered from a prior trip had been stuffed and set up in a rather weird display.

After breakfast at Los Arcos, we hired a taxi to take care of us for several hours. Our driver, Luis', first stop was The Moorings' new base at the recently



"What's the matter? Never seen anybody slice up a ray before?" Life is simple at Isla Coyote, but the fishermen are friendly.

completed Marina Costa Baja.

Some of the crew went to the *mercado* for provisioning, then picked up Boone

at the airport, while I did a chart briefing and boat checkout. Before leaving, we ran into our friend Craig Adams, who was there on his own boat, *Infinnity*. He made a gift to me of his favorite fishing lure, a cedar plug, and we ended up sailing with *Infinnity* for a few days, until we turned back at Puerto Escondido.

Craig swore by that cedar plug, and it did attract our biggest fish. But, sadly, the fish got away after stripping out 200 feet of line. Whatever it was, we couldn't land it despite chasing it with the cat. That was quite a battle.

I'd been thinking, conservatively, of a short cruise up the coast because of our afternoon departure. But Craig thought we should cruise straight up to Partida Cove. He was right, as Partida Cove is a lovely anchorage between Isla Partida and Isla Espiritu Santo. We dropped the hook in the Eastern part of the cove in shoaling water — the closest boat to the beach. By this point we were already loving the cat.

We soon discovered that, although everyone brought iPods, there was no iPod connection to the stereo. I always

BRITISH VIRGIN ISLANDS "BEST DEALS ON KEELS"



- Most selection of sailboats 32'-52'
- "Purr" with cats 38'-47'
- Bare boat or skippered
- Best yacht management program

Conch Charters
Est. 1986

NEW YACHTS IN FLEET!

www.conchcharters.com
Email: sailing@conchcharters.com
Call our 'Sails' Office
(USA) (800) 521-8939
Tel (284) 494-4868 • Fax (284) 494-5793

Sail paradise with Conch Charters

CALIFORNIA'S CARIBBEAN CONNECTION

SAN JUAN ISLANDS SAILING SCHOOL

Fly to Bellingham, WA
Explore the spectacular San Juan Islands!

Week-Long Learn-N-Cruise

During your live-aboard week out in the islands, you'll complete American Sailing Association's Basic Sailing through Bareboat Charter Certification.

Tax Exempt Tuition Only **\$1295** Includes Food!
(Airfare SFO/OAK to BLI approx. \$300)

No Experience like this for the price in the SF Bay Area!

1.800.677.7245
www.sanjuansailing.com

SCHOOL





CHARTER

40 Exceptional Yachts
from 31 - 49 feet

25 Years of Sailing Excellence

We certify more Bareboat Skippers than any other school in the Northwest!

WORLD

bring a back-up set of CDs, and so did Geoff, mostly Grateful Dead. Our boating theme became "All Dead, all the time."

The next morning, Geoff, Donna and I dinghied over to the El Cardoncito for a bit of great snorkeling. Afterwards, we weighed anchor and set sail for our next destination, Isla San Francisco.

After a pleasant sail of roughly 20 miles, we reached "The Hook" at Isla San Francisco. En route, Roberto immediately caught a number of fish, which we assumed were bonito, and we made ceviche. We also saw amazing numbers of manta rays jumping out of the water. Initially, we stopped to observe them, but there were so many of them in the area that later in the trip we just kept cruising.

The Hook is a wonderful anchorage. We chose a spot close to the beach, away from other boats. That night we enjoyed dinner with Craig and his crew, Brandon. It was decided that the next day's destination would be El Puerto Gato, aka "Gato y Toro."

Just North of Isla San Francisco is a very small island named Isla Coyote,



ALL PHOTOS ART HARTIGER

Kelton's Cove, on the east side of San Jose, is a beautiful day anchorage. The weather was so calm, Art and Co. decided to overnight there.

which is inhabited by a few Mexicans living a "hardscrabble life," according to Geoff. The Moorings chart referenced

"dancing" and "shopping," and it was such an unusual location, we had to check it out. We dinghied in and walked around the island. The inhabitants were very friendly, and we enjoyed tooling around, stretching our legs and buying some jewelry.

We asked for ice at Isla Coyote, but there was none. They pointed us to San Evaristo, so we departed for our new destination, about 10 miles north on the Baja peninsula, on the way to El Puerto Gato. After arriving at this lovely spot, we dispatched the dinghy, without anchoring, to investigate the situation. Our crew members returned with ice, but with instructions that we were not to ingest it under any circumstances. This was fine with us, as we were mainly looking for a way to keep more beer cold.

Here, we encountered the first of many pods of dolphin that we would see during the trip. After spotting us coming toward them, they would swim over and dance in our bow wake. It was amazing cruising alongside these beautiful creatures.

☰ Mission Creek Sail Tours, LLC



Sailing San Francisco Bay Since 1996

San Francisco, "The City by the Bay", is one of the most exciting destinations in the world and the most memorable way to experience it is from the water aboard your private sailing yacht.

Romantic Sunset Sails • Private Bay Tours
Wine Tasting Cruises • Corporate Team Building

Conveniently located at South Beach Harbor
(between AT&T Park and Pier 40)

408-910-0095/408-377-2824
 Charters@sfsailtours.com
<http://www.sfsailtours.com>
 Call or email us for a *free brochure*

'Imi Loa
San Francisco, CA

SAIL HAWAII

Captain/Crewed Sail & Motor Yacht Charters



PACIFIC YACHT MANAGEMENT
 808.226.3496 • info@pacyacht.com
www.pacyacht.com

**CHARTERS BY
BELLHAVEN**



www.bellhaven.net
800-542-8812
bellhaven@bellhaven.net
 714 Coho Way Bellingham WA 98225

Bellhaven
Yacht Sales • Sailing School • Charters

CHARTERS: BC Canada • Mexico • Offshore

Trips available for groups, individuals or couples
 57-ft Luxury Sailing Vessel **WESTERN GRACE**

• Private Charters BC Canada & Mexico	\$5,000-\$11,000/week
• Around Vancouver Island	Sept. 6-20 \$2,800/p.p.
• Victoria, BC, to San Francisco	Oct. 2-10 \$1,800/p.p.
• San Francisco to Cabo San Lucas	Oct. 16 - Nov. 7 \$2,680/p.p.
• Cabo San Lucas to La Paz	Nov. 10-17 \$900/p.p.
• La Paz to Puerto Vallarta	Nov. 30 - Dec. 10 \$1,400/p.p.
• Puerto Vallarta to Hilo, HI	Mar. 29 - Apr. 23, 2009 \$2,680/p.p.
• Hilo, HI, to Victoria, BC	Apr. 29 - May 22 \$2,680/p.p.

www.WesternGrace.ca
 808.271.3540
sailaway@westerngrace.ca



OF CHARTERING

We reached Puerto El Gato, and were soon greeted by Manuel who wanted us to buy lobster from him and supply him with booze. We negotiated to buy six lobsters, plus four more for *Infinity*. Sure enough, in the morning he returned on schedule with our order, which inconveniently displaced our *cerveza* in the cooler.

After some of the crew took a hike through a cactus forest, we headed out toward our next destination, Agua Verde, about 16 miles north.

Agua Verde is a beautiful anchorage, with a distinctive rock outcropping at the entrance, and three distinctly different spots to anchor inside: the left (the SE Bight), middle (off the beach) and right (the NW Bight, off the Agua Verde Beach Club). *Infinity* arrived ahead of us, 'warned' the cruising community of our impending arrival, and anchored in the more crowded NW Bight. We cruised around a dozen boats in that area and opted to head across the bay to the SE Bight, where there was only one boat. (We were hopeful that its crew were Grateful

Dead fans.)

The lobster dinner that evening was wonderful. Craig and Brandon dinghied over with a bottle of tequila and their own four lobsters, and we had a feast. After parboiling them, we popped them on a mesquite grill, and served them up with drawn butter. Mmm, delicious.

The crew really wanted to keep moving north, so we weighed anchor early for the trip to Puerto Escondido (20+ miles). From there, we planned to catch a taxi to Loreto, look around, and then decide our next move. En route we saw four whales and numerous manta rays doing backflips.

We dropped anchor in Puerto Escondido about 10:30 a.m., then headed to the dinghy dock. A taxi miraculously ap-



Off Santa Cruz Island, Art bagged a 30-lb dorado that he named Mauricio, which fed the crew for two days.

peared, and we negotiated a \$65 fare to Loreto. In town we had fish tacos, bought tequila and ice, and had a look around town.

Our next stop was Isla Monserrate, an island about 12 miles to the southeast. No overnight anchorages were listed, but the weather was so calm we decided to drop the hook at Yellowstone Beach. This spot was gorgeous. We were the only

Closest full-service charter base to Desolation Sound & Princess Louisa Inlet

Visit our Web site for a preview of our 25' to 54' Power & Sail fleet

BOOK YOUR CRUISING ADVENTURE NOW
Check out our New Lower Rates!

e-mail charter@desolationsoundyachtcharters.com
<http://www.desolationsoundyachtcharters.com>

#101-1819 Beaufort Ave., Comox, BC, Canada V9M 1R9
TOLL FREE 1-877-647-3815 FAX (250) 339-2217

ANACORTES YACHT CHARTERS
PACIFIC NORTHWEST ADVENTURES

Largest Selection of Charter Yachts in the Pacific Northwest

Bareboat & Skippered

Power and Sail 28'-66'

Charter Yacht Ownership

Yachting & ASA Sailing Schools

Enjoy Yachting for a Lifetime with the World's Best!

Rated #1 by Cruising World

www.ayc.com 800.233.3004

GET READY for the CARIBBEAN!

1. Pack for the sun.
2. Go to the airport.
3. Meet our friendly staff.
4. Sail away for the day or month.
5. Sunbathe. Snorkel. Wine. Dine.

YACHTS from 31-52 feet
Crewed yacht charters available
10% off to repeat customers
Monthly specials

Joma Marina, Port Purcell, Tortola
284-494-4289 or 888-615-4006
fax 284-494-6552
charters@bviyc.com

WORLD OF CHARTERING

boat at the anchorage, and some of us dinghied in to enjoy a private walk along the beach.

In the morning we departed early for Isla San Jose, an island more than 40 miles to the south. Our objective was to sight a blue whale, so our course took us more easterly than perhaps necessary. We deployed the fishing lines, and off Santa Cruz island we were rewarded with the capture of a 30-lb dorado which we named Mauricio. He fed us for the next two days.

Next, we moved on to Kelton's Cove on the east side of San Jose, another day anchorage. But the weather was very calm and the anchorage so beautiful that I thought overnighting was an acceptable risk.

We had a great day, preparing dinner and later experiencing the beautiful luminescence in the evening while swimming. I'd read in *Latitude* about the bees, and sure enough, a bunch of them visited us, apparently seeking our fresh water.

The next morning we cruised to our last anchorage, El Candalero, 15+ miles



ART HARTIGER

Ceviche anyone? Art and the gang caught this small school of bonito, which they chopped up into classic Mexican hors d'oeuvres.

away. Along the way, we stopped at Los Islotes, a "must" stop according to The Moorings. The main attraction of this tiny outcropping of rocks is a resident colony of sea lions. It's truly a day anchorage, just north of Isla Partida, with day buoys for charter diving boats. Some of us deployed the dinghy and jumped in for a "swim-with-the-sea-lions" experience. We were not disappointed, as we

experienced an exhilarating rush when the sea lions swam straight at us.

El Candalero is a fantastic anchorage. We moved up into a beautiful turquoise cove with just one other boat in sight and dropped the hook — truly a beautiful spot. There we witnessed a fascinating exchange between a pelican, a gull and a vulture. The loser was the vulture, who was eventually pecked to death. This was our version of nature theatre.

With the boat due back at 10 a.m., we weighed anchor early and headed in. The Moorings folks did a great job checking us in, and we reluctantly headed off to the airport. We're still thinking about this great trip, and will probably be back again someday for round two.

— art hartinger
south beach harbor

Art — Thanks for your detailed report. We're tempted to follow in your wake sometime soon. But we're not sure we'd have the same luck fishing. We'll put some Latitude swag in the mail to you as a 'thank you'. So, where to next?

— Ed.

JUST YOU AND THE SEA...

Punta Mita Beachfront Condos

Call now for winter reservations!

1.415.599.5012

www.puntamitabeachfrontcondos.com



Society of Accredited Marine Surveyors®

Serving Northern California

Al Blair, SA
415.456.3154
blairsurvey@msn.com

Jesse Brody, SA
415.342.0757
jesse@baymarinesurvey.com

Odus Hayes, AMS®
415.461.8425
ohayesurvey@comcast.net

Alan Hugenet, AMS®
415.531.6172
hugenet@comcast.net

Tom List, AMS®
415.332.5478
listmarine@yahoo.com

Jack Mackinnon, AMS®/SMS
510.276.4351
surveyjack@aol.com

Randell Sharpe, AMS®
877.337.0706
rsharpe@alamedanet.net

Terry Tucker, SA
510.381.1925
ttucker100@sbcglobal.net

Sold My Boat!

"As a result of my Classy Classified in the May issue of *Latitude 38*, our boat sold quickly. Thanks for your help in making the placement of the ad easy and for your great customer support!"



If you want a proven method to sell your boat, get your ad into the next issue of *Latitude 38* – the deadline is the 18th at 5:00 pm. A 40-word ad is just \$40, and best of all, you can do it online!

www.latitude38.com

HONDA MARINE
IT'S ALL ABOUT POWER.

caribe
INFLATABLES

Aquapro
INFLATABLES



HONDA MARINE
IT'S ALL ABOUT POWER.

TOHATSU
outboards

Achilles

We've been **THE Bay Area** authority for inflatables and outboards for more than 35 years.

Call us today for quotes.

Voyager Marine

1296 State St.
P.O. Box 246, Alviso, CA 95002-0246
(408) 263-7633 • (800) 700-7633
Open Tuesday thru Saturday



CHANGES

With reports from **Aurora** on landing a big mahi on the way to New Zealand; from **Moonduster** with the straight dope on singlehanding; from **Manu Rere** on the Gulf of Fonseca; from **Rhapsody** on Alma, the first tropical storm of the season; from **Sea Angel** on the last passage of the Caribbean season; from **Tropical Dance** on a 'double turtle save'; from **Moonshadow** on cruising expenses in the Med; from **Imagine Me And You** on doggie help from Singlar in Santa Rosalia; from **Lucky Star** on Glacier Bay; from **Tenacity** on a whale of a photo off Mazatlan, and lots of **Cruise Notes**.

Aurora — Morgan 38 Jim and Pam McEntyre The Big Fish (San Pedro)

Here's a fish picture for you! My wife and I had spent a lovely '06 season sailing our Morgan 382 from Panama across the South Pacific to the Galapagos, French Polynesia, and so forth, and finished up the season in Tonga. It was then late in the cruising season, and we needed to leave Tonga for New Zealand to avoid being caught by an early-season tropical cyclone. We patiently waited for a weather window while happily anchored next to Motutapu Island, which is near the capital city of Nuku'alofa at the southern end of the Kingdom of Tonga.

Getting to New Zealand from Tonga requires a 1,000-mile dash across the notoriously treacherous waters between Tonga and New Zealand. We were in daily contact with New Zealand weather guru Bob McDavitt hoping for a window, but there just didn't seem to be one, so we waited and waited. But eventually, after a strong frontal system passed through, McDavitt told us to scoot. So we weighed anchor and took off in the fresh breezes

This beautiful mahi was hooked just as Jim and Pam were bringing in the meat hook because the wind had come up.



AURORA

and leftover lumpy seas. We began flying along at hull speed almost as soon as we cleared the islands — even though we had the genoa rolled in to 105% and a double reef in the main.

We decided we should reduce sail a bit more because of the threat of increasing winds, but before doing that, we pulled in our 'meat line' because it was beginning to become too rough to fish anyway. I had just reached for the line to pull it in when it jerked bar-taut and the shock cord snapped out to the limit! There wasn't just a fish on the line, it was a big one! I had no choice but to bring in the line, so I got on my knees and slowly muscled away at it, all the while slipping and sliding on the wet deck. It took me 20 minutes to land and subdue what turned out to be a five-ft, 40-or-so lb. mahi. It took me another hour to filet the fish on the side deck. The big seas actually helped, by occasionally sending clean seawater along the weather deck to wash away the blood.

We ate fresh mahi until eight days later when we arrived at our check-in port of Opuia, on New Zealand's North Island. Whereas New Zealand authorities are very careful about preventing any raw meat products from coming into their country, they have no concerns whatsoever about fish, so we were able to keep all the remaining fish in our freezer and later share it with cruising friends. Many a cruiser belly was made happy by that one fish.

— jim 06/02/08

Moonduster — S&S 47 Wayne Meretsky Straight Dope on Singlehanding (Alameda)

When I get to the end of an ocean passage, I invariably meet other boats who have done the same crossing at the same time with really only one difference — they have crew. It's usually a couple, but sometimes three or four. The conversation usually starts with curious questions: "Do you ever sleep?" or "How do you stand watch?" or "Do you eat a lot of freeze dried foods?"

The reality is that, as a singlehander, I sleep and eat really well, and generally arrive more rested and in a better frame



BOTH PHOTOS COURTESY LITTLE WING

of mind than those traveling with friends or spouses. The rationale is a little hard to digest at first blush and is sure to be controversial, but the reasons are simple. Measured per person, there's much more food in the fridge, water in the tank, and juice in the batteries when there's but one person on the boat. I took at least one shower a day, and was able to enjoy eating fresh meats, vegetables, and salads every day during my 20-day passage from Mexico to the Marquesas. The math is easy and shouldn't cause much of a stir. There's just no way I could have pulled that off if there had been another person on the boat.

As far as rest and energy reserves go, this is where eyebrows start to raise and heads start to shake. I've sailed quite a bit, doublehanded and fully crewed, and have found there is nothing less restful than trying to manage watch-and-watch with one other person. You just can't be fully rested trying to swap two-, three- or



run down are pretty much over. I routinely get AIS hits on commercial vessels from 100, 150 or even 200 miles away.

Second, by being really well rested and well fed, I find that I'm far more mentally and physically prepared when something needs attention or when something really goes wrong. What do I mean by well rested? I usually have three alarm clocks set on 30-minute intervals at night and on 60-minute intervals during daylight hours. They are battery-powered digital kitchen timers that cost about \$6.95 at Longs Drugs. At times, I'll sleep through one of them, but I haven't slept through all three in the last 10 years.

Have I had any close calls? Yes. In '98, when I was sailing solo from Manzanillo to Hawaii, I was in a low pressure trough with considerable rain for about five days. The radar watch alarm was useless because the rain constantly triggered the alarm. After being awake pretty much continuously for three days, I finally fell asleep for perhaps four to six hours, sleeping through all three alarms. When I awoke, it was in a dead start, and when I shoved the companionway hatch open to take a look while

Spread; The carefree life, swinging in 'Moon-duster's spinny seat off an atoll in the Tuamotus. Inset; Singlehander Meretsky.

four-hour watches. And when you are on watch, looking at someone else's dirty dishes in the sink, laundry on the settee, or chicken scratches on the chart tends to just drive you crazy after 10, 15 or 20 days. By contrast, my crew's personal hygiene, organizational, navigational, sail trim and culinary skills are perfectly aligned! There's no discord or subtle tensions, no discussions being rehearsed while they're sleeping peacefully and I'm trying to cope with their best efforts. It always works perfectly.

So that really leaves just one question, "How do you stand watch?" And herein lies the tricky part, because I really don't stand watch at all. Having sailed plenty of miles doublehanded and fully crewed, I've always been miffed at how little gets noticed by the other crew standing watch. Whether it's running

lights on the horizon, a temperature gauge that has crept up 10 degrees, or the fact that the wind speed has fallen and it's time to shake out that reef, I find that, in the middle of a 15-day passage, the mid-ocean malaise has reduced the attentiveness of most crew — myself included — to a pretty low standard.

My solution is twofold. First, throw technology at the problem everywhere possible. I run my radar in 'watch' mode on 10 or 20-minute intervals with a programmed zone that is usually out to 20 miles. My wind speed, wind direction, compass heading, course, cross track error, way point arrival, and depth all have programmable alarms that would likely wake the dead. For this cruise, I've also added AIS to the mix, and have come to believe that, so far as commercial shipping goes, the days of being

the radar was warming up, there, dead ahead, was a Panamax container ship with range lights perfectly aligned less than a quarter mile ahead. The panic lasted a few seconds, and I turned to the right about 45 degrees and quickly opened up a decent passing lane. I talked

Wayne, Alanna Coady, Pat Boggs, and John Boggs, the latter three of the Beneteau 473 'Don Pedro', at Taiohae Bay, Nuku Hiva.



KAY COMPTON

CHANGES

to the profusely apologetic master of the ship for about two hours, until we were out of VHF range. The adrenaline dump kept me up for the next two days.

That situation never would have occurred in an AIS-equipped world. The only close encounter I had this season was with a military vessel that popped up at 15 miles on radar. Unfortunately, the military kids refuse to operate AIS even when in U.S. coastal waters, which I think is just dumb, dumb, dumb.

What's the hardest period of time for solo sailing? I find that there's a lot to do during the first eight to 12 hours, mostly because I never really have the boat squared away before I leave, regardless of how hard I try. Then wind conditions change as one clears the coast, and there's lots of sail trim to deal with, preventers to set, alarms to program, and so forth. At the end of those eight to 12 hours, I'm pretty tired, but if I can get one to two hours of good rest, I can start to fall into the groove. But if the whole trip is just 12 to 18 hours long, then the opportunity for rest is usually lost and I arrived exhausted. It's for that reason I don't really like 100- to 150-mile hops.

Have I ever been caught short because I was singlehanded? There are plenty of times when I've been really concerned about my ability to handle some tricky situations. In the Tuamotus recently, my anchor chain became badly fouled on some coral. When the wind shifted and the anchorage became very choppy, it was clearly time for me to move. I dove on the rode and found a total mess. But a

little patience, a really good windlass, and a little luck saw the situation resolved with no drama at all.

More problematic was side-tying to a barge in Papeete, as I was approaching a dock for the

first time in two months and with a 15-knot cross breeze blowing me off the dock. My spot was also surrounded by other boats, and there was nobody on the dock to take a line. I pulled in perfectly, and stepped off the boat with a bow and stern line in one hand. But with the crosswind and no cleats on the dock, it was a real struggle to get both lines secured in the silly rings on the dock without losing control of the boat.

In fact, my boat got about 15 feet away from the barge before I could get her secured. I've had similar docking problems in the past, most always due to strong crosswinds.

That's not to say that it's always been so easy. Having done the solo thing for over 15,000 miles has resulted in quite a bit of confidence, most of it deserved. I've learned more than a few tricks from other solo sailors, refined many of my systems, and I make different trade-offs than in my earlier days. Plus, I spend a lot of time thinking through landfalls and planning contingencies.

In the end, solo sailing is still very controversial. I've only met four other singlehanded boats this season out of the 1,200 that I've seen here in French Polynesia. Many skippers and crew are adamant that it's not possible to be safe when sailing solo. The establishment, as measured by insurance companies, is also dubious of those of us who sail alone. I was only able to get one quote for sailing singlehanded offshore, and it came to nearly 10% of the coverage amount.

But for me, regardless of the controversies and despite the risks, the experience of watching Fatu Hiva slowly materialize out of the mist as the sun rose on the 19th day out of Puerto Vallarta was the culmination of endless dreams and countless hours of planning. And of all the accomplishments in my life, there's been nothing more satisfying than having done it alone.

— wayne 06/17/08

Manu Rere — 38-ft Homebuilt Cat Glenn Tieman Gulf of Fonseca (Southern California)

It took me two full weeks of sailing to make my way from Huatulco, Mexico, along the Gulf of Tehuantepec, around Guatemala and most of El Salvador, then back deep into the Gulf of Fonseca to reach the backwater of La Union, El Salvador.

The Gulf of Tehuantepec is a dangerous place because the wind is accelerated through one of the narrowest parts of Central America at Salina Cruz. My boat doesn't have an engine so, unlike most cruisers, I couldn't just motor across the wide gulf during a big weather window. Fortunately, May, the month I was there, is historically the safest month for making the crossing. In addition, I followed the well-known technique of staying very close to shore. This meant that, if the offshore winds did come up,



they wouldn't have much fetch in which to build up huge seas. As it turned out, I had an excellent sail across the Gulf.

By the time I'd reached southern Mexico and was ready to make my jump across the Gulf, typical rainy season weather conditions had arrived. That meant many black thunderstorms, with heavy rain at night with calms and headwinds during the day. The weather was so foul at night that I usually just took down the sails about midnight and slept soundly.

It turns out that Guatemala charges exorbitant fees for private boats, so I didn't stop there. Most boats stopping in El Salvador do so at either Barillas Marina or the Hotel del Sol. Both are resort facilities reached by crossing a bar into a lagoon. But I wanted to see the 'real' El Salvador, so I elected to stop at La Union, a town that is definitely off the tourist trail. Unlike in Mexico, where the people have been jaded by all the tourists, the locals at La Union treated me like a curiosity.

There was another boat with me in



'Rere's beam lashings.

IN LATITUDES



BOTH PHOTOS LATITUDE/RICHARD

Spread; 'Manu Rere' is spacious, but somewhat lacking in accommodations. Inset; Glenn holds up a classic kerosene running light he uses.

La Union, *Tao8*, which I'd previously crossed paths with in Mexico. Unfortunately, they'd had fuel containers stolen off their decks at night, so La Union isn't about to lose its reputation for being unsafe. When I went ashore, I'd tie to a Salvadoran naval ship and then walk through the base to town. The officers, who were also some of the officials who cleared me into the country, said it was the safest way for me to come ashore, but it still wasn't a very comfortable arrangement. As it turned out, I was challenged at the gate once, but said, "*El Capitán del Puerto me permite al pasa aquí.*" At that point I was waved through.

After provisioning at the fabulous public market, where the exchange rate was three *sapotes* to the dollar, making an improvement to the mainsail, and sending this email, I'm about to head out to the islands in the Gulf of Fonseca, which are home to smaller villages. After that, I'll continue on to Honduras, which

is on the other side of the Gulf and has a very limited coastline presence on the Pacific Ocean.

— glenn 05/29/08

Rhapsody — Beneteau Oceanis 510 Pat and Trish Horton Along Came Alma (San Diego)

In preparation for leaving Puntarenas, Costa Rica on May 27, we checked the GRIB files from SailMail and the other forecasts we get from *buoyweather.com*. Since neither indicated any unusual weather, we went ashore on Tuesday to play a little pool and have a last beer before departing the next morning. While shooting pool, Noel DesMarteau and his family on the *Astoria*, Oregon-based Morgan 452 *Ketching Up* took the floating dock in front of ours, then came into the yacht club. Noel reported that their dinghy and outboard

had been stolen the night before at Islas Cedros/Jesuitas — even though they'd lifted the dinghy out of the water and secured the outboard on a mount on a stanchion.

It was bad enough that someone had stolen their dinghy and outboard, but the fact that someone boarded their boat to do it was downright scary. Trish and I had been anchored at the same place for three days the week before. In addition to learning that *Argonauta 1* had also had her dinghy stolen there, I noticed a few shady looking characters eye-balling *Rhapsody* as they slowly rowed around in their canoes. After Noel told us about their theft, we checked on the web for other reports — and found that several other dinghies and motors have been stolen from Cedros/Jesuitas in the past few months. So a word to the wise.

While Noel was sharing his bad news, we mentioned that we'd be leaving the next morning. He offhandedly asked if we'd seen the forecast for 17-ft seas for the next day. We hadn't. It had been a long time, in fact, since I had checked the sea state, being more interested in forecasts for the wind, lightning, and rain. As we were leaving, Michael and another guy from the 32-ft sloop *Harmony* said they were planning on leaving the next day also. When we mentioned the forecast for high seas, they said they were going to leave anyway. After urging them to reconsider, we returned to *Rhapsody*, where, thanks to our nifty long-range wi-fi antenna, we were able to check the weather again via the Costa Rica YC.

Sure enough, *buoyweather.com* was forecasting 11 to 17-ft seas, but had upped the wind forecast to a still-relatively mild 12-18 knots. Trish and I decided to postpone our departure. When we awoke the next morning, we saw that ***The berthing at the Costa Rica YC is in the middle of the estuary on individually anchored docks — perfect for snagging debris.***



RHAPSODY

CHANGES

Harmony had left. We tried to raise them on the VHF to warn them about the seas, but were unsuccessful.

Since we weren't leaving, we decided to join Bruce and Marianne for champagne and Trivial Pursuit aboard their *Gallivant* at 4 p.m. By 5:00, it was raining quite heavily. When we left *Gallivant* to return to our boat at 7 p.m., we got drenched covering the 30 feet between the two boats. Six or seven hours later, in the wee hours, we were awakened by strong winds and heavy rain. The instruments showed gusts to over 30 knots, and it was raining so hard we couldn't think.

It wasn't raining or blowing as hard at dawn, so we slept in. About 9 a.m., we started to hear things bump into the boat. Since the Costa Rica YC is on a river estuary, and we had seen a few logs and branches floating downstream during our stay, we figured we were hearing the usual stuff. But when we stuck our head outside, we were astounded to see dozens of trees and logs floating down the river, quite a few of them thumping and bumping as they glanced off *Rhapsody*.

It quickly became apparent that the quantity of debris could become a problem, and occasionally a tree limb or some debris would get stuck between our boat and the dock, threatening to pull us loose from the dock. So Trish and I, along with several of the yacht club workers, began clearing the debris from *Rhapsody*, and were barely able to keep pace with the arrival of new debris. Meanwhile, Bruce, Marianne, and Gene were keeping the debris from *Gallivant* and *Caravan*, the next two boats downstream from us. Noel, Ashley and the boys on *Ketching Up* were lucking out as, for some reason, their boat didn't seem to catch any

All manner of debris came down the river to bump into 'Rhapsody', including a live armadillo and a dead crocodile.

debris.

After about an hour of keeping pace with the arrival of new debris, we all looked up to see a huge island of stuff headed right for our *Rhapsody*! Everyone stopped working for a second or two, as what must have been a ton or more of trees, limbs, and trash caught between *Rhapsody* and the floating dock she was tied to. The water was moving down the estuary at perhaps five knots, so this debris packed a wallop when it jammed itself between our boat and the dock. Soon there was an island of debris large enough to walk on! And the force of the current on the island was so great that not only was I afraid the docklines were going to part, but that one of the cleats would be pulled out of the dock. The force was so great that it was already bending two half-inch steel bolts sideways and threatening to pull them through four-inch-thick hardwood!

The debris island contained a lot of the usual stuff, but also a railroad tie that used to be part of a fence and was wrapped with 20 feet of barbed wire. What a mess! In addition, there were all kinds of lizards, frogs, and even a few snakes in the mix. About this time one of the dockworkers gave a holler and pointed out a good-sized armadillo in the pile! The workers rescued it, picking it up by its tail, and put it in a 5-gallon bucket until they could release it properly later on. A short time later, everyone stared incredulously as a 12-ft dead croc, his feet up in the air, floated by. He must have been hit by a falling tree or something.

After the initial shock of seeing all of the debris pile up, I argued that we just needed to wait for the tide to change and for the problem to "fix itself." But Rudolfo, one of the workers, told me there was too much water coming down the river, and even when the tide tried to change, water would still be flowing out. So it was either keep cleaning the debris away or risk *Rhapsody* breaking loose and drifting down on the boats further downstream.

For the next five hours or so, Trish and I, helped by six workers from the yacht club, as well as Gene from *Caravan*, battled the debris. Several other workers got into *pangas* and worked to clear the pile away also. After all those hours of hard work, one of the workers tied a rope to a large log in the middle of the 'island' of debris, then gunned his *panga*. That managed to get the bulk of the debris free of our boat. After another hour or so of work, *Rhapsody* was completely free. In order to prevent a repeat



of what had happened, the workers tied *Rhapsody* to two mooring balls, then cut the floating dock away.

After a very hard and messy day, *Rhapsody* was still covered with trash, bugs, and twigs, but at least she was safe. Trish and I were still sore the next day from all the backbreaking work, and don't know what we'd have done without all the help we'd received.

While watching Costa Rican television that night, we learned that we'd been hit by parts of tropical storm *Alma*, and had been very lucky to have stayed in Puntarenas. The next morning it was reported that the sailing vessel *Stravaig*, having lost their engine and sails in 60-knot winds and 30-ft seas in the Gulf of Papagayo, had to be rescued by the Costa Rican Coast Guard. They eventually made it to Nicaragua. Nonetheless, the storm was blamed for three deaths in Central America.

As for *Alma*, instead of heading northwest as most Eastern Pacific tropical storms do, she headed northeast across Nicaragua, and emerged in the Carib-



RHAPSODY

IN LATITUDES



PHOTOS COURTESY SEA ANGEL

Spread; 'Sea Angel' heads for a summer on the hard in Trinidad. Inset; The Trini boatyards are popular for off-season storage.

bean as tropical storm *Arthur*. We never did hear anything about *Harmony*. They were headed for 600-mile-distant Ecuador, so we hope they made it.

— pat 06/05/08

**Sea Angel — Peterson 44
Marc Hachey
Last Passage of the Carib Season
(Auburn)**

With the North Star dead astern and 12 degrees above the horizon, and the Southern Cross serving as a guiding light off my bow, I sailed out of Prickly Bay, Grenada, at 1 a.m. on June 1. My destination was Chaguaramas, Trinidad, approximately 80 miles to the south. The sky was mostly clear with only a few clouds and, since the new moon was only two days away, it was a perfect night for viewing the stars. They all looked bright, including the planet Jupiter, which was directly overhead. Only a sliver of the moon rose above the horizon, and not

until around 4 a.m., about two hours before the welcome sunrise. When singlehanding, the nights always seem very long, but no matter how tired I am when the sun peeks above the horizon, I always feel reenergized at the beginning of a new day.

My last passage of the season couldn't have been much nicer. I'd sailed out of the bay under full main and a 100% yankee-cut jib in 17 knots of breeze. The average winds turned out to be 15 to 20 knots at about 65 degrees off the bow — in other words, absolutely perfect! This passage typically features some strong currents, mainly westerly setting, and others with a north or south flow. But on this night, I definitely had the west setting current, as my compass heading was as much as 19 degrees east of my actual course over ground. Fortunately, the wind was north of

east instead of the south of east that is normal for this time of year, so I was able to stay on my planned course. I also had some favorable current from aft, but none on the bow — also unusual for this passage. But as a result of all the different factors, a good portion of my trip was made at 7+ knots over the bottom, in seas that were in the pleasant three- to six-foot range. In this part of the world, sailing just doesn't get much better.

At present, I'm tied stern-to at the Peake Yacht Services boatyard jetty, preparing to haul *Sea Angel* for another hurricane season. The season officially started on June 1, the day I arrived. I'm always amazed at how much work is involved with preparing a boat to be left for an extended period of time. Normally, I need about a week at the dock, rinsing and removing sails, removing salt from lines — and just about everything on the exterior of the boat — as well as removing surface rust, polishing stainless, and so forth.

As I was doing my initial rinse with a hose in my hand, I realized that it was the first time that *Sea Angel* had been at a dock all season, and therefore it was the first time all season I'd had a chance to take a hose to her. The previous time was in November when I was buying diesel for the trip from the Northeast down to the Caribbean. My engine hour meter shows that I've put a total of just 100 hours on the Perkins since June of last year — which is an average of only about nine hours a month. That means a pretty small carbon footprint. After *Sea Angel* is secured on jacks in the boatyard next week, I'll flush the engine and refrigerator cooling system with fresh water, secure all her covers to protect her from ***If you spend the winter sailing and hiking in the Caribbean, there is no way you're not going to be fit — and eager for the next season.***



LATITUDE/RICHARD

CHANGES

the tropical sun, and finish my interior cleaning.

By the time I'm seated in an aluminum tube flying me back to the States, I'll be ready for a break from all the work associated with cruising mostly solo. On the other hand, I'll know that by the end of summer I'll be anxious to return to the Caribbean and get back to cruising — and hiking — in the islands I've come to know and appreciate more each season.

— marc 06/03/08

Tropical Dance — Gulfstar 50 Dan and Reylyn Yarussi A Double Turtle Save (San Clemente)

Dan and I, along with surfer/photographer Andy Conlin of Ventura, made a 'double turtle save' last month while on a passage from Zihua to Acapulco. We were motoring at about seven knots when we saw two turtles about 100 yards off our port beam. Using the binoculars, I got a closer look and could see yellow floats around the turtles. Then we saw the netting that had snagged them.

"Let's go free them!" said Dan. Andy and I immediately agreed. I switched the autopilot off, pulled a 'U'-ey, then came alongside the trapped turtles. It was quickly apparent that they were caught

With the task made more difficult by the Gulfstar Sailmaster's high freeboard, Dan Yarussi struggles to cut the turtles free of the netting.



ANDY CONLIN

in snags from hell.

One of the big problems in freeing the turtles was that our Sailmaster 50 has unusually high freeboard. As a result, I ended up using the extendable boathook to pull the mess out of the water, which allowed Dan to reach down and cut away at the net. But it wasn't easy — in fact, one knife fell into the water and sank. Ultimately, I had to lift the net and the weight of the two turtles just so Dan could get a good angle for cutting the lines.

The whole operation took about 20 minutes, but I'm proud to say that we freed both the turtles. I wish we could have taken the net aboard to prevent other turtles from getting snagged, but there was a baby shark and a couple of dead fish in it, so it wasn't something we were able to deal with. Plus, during the whole rescue operation there were quite a few fish swimming below, including something really big — we couldn't tell exactly what it was — about 30 feet down. But it could have been a big shark hoping to have a turtle for lunch.

— reylyn 05/05/08

Moonshadow — Deerfoot 62-2 George Backhus Cruising the Med (Sausalito)

Twelve years after doing the Ha-Ha, we're still cruising, and are presently in southwestern Turkey heading north into the Aegean. Folks in California who are thinking about cruising the Med would no doubt be interested in the price of things in this part of the world. We've found them to be fairly reasonable compared to what other cruisers have told us about the prices in the Western Med. It's our understanding that the costs get progressively more expensive as one heads west.

We paid about US\$500/month for out-of-the-water winter storage in southern Turkey. It would have cost twice as much at the more popular wintering-over spots on the west coast such as Bodrum or Marmaris. On a casual basis, mooring in a marina will cost more than \$100/day, but an annual contract will bring the cost down significantly. We generally avoid marinas unless we need to get some work done. The smaller Turkish towns have municipal harbors where one can tie up and get power and water for \$25 to \$50 a night. We pop in to these lovely little spots for a couple of days a week to do some sightseeing and provisioning, and maybe enjoy a meal out. We filled up with diesel at the end



of last season, well before the current fuel situation, when it only cost about \$6/gallon. I haven't checked prices this year yet.

Food prices are average in Turkey. A decent dinner out — two starters, two mains, a side dish/salad, and a reasonable bottle of wine — costs from \$40 to \$80 depending on the location and quality of the restaurant. We usually have breakfast and lunch aboard *Moonshadow*, and have dinner out about twice a week. Merima is pretty good at learning how to prepare local foods, so we often eat Turkish/Greek onboard. A good beer ashore is about \$4 to \$5, and a glass of wine is about the same. You can buy a bottle of Turkish wine in the markets for \$10 to \$20.

We spent a couple of months cruising the Greek Isles last summer, where there are municipal harbors rather than marinas. While the cost to tie up was usually a euro or two a night, power and water were expensive, running about \$20/day. The water is expensive because most Greek Isles get little rain and have



GEORGE BACKHUS

Among 'Moonshadow's most recent stops has been Kastellorizo, a lovely little Greek island a few miles off the coast of Turkey. "It's very quiet and cool, doesn't get too many tourists, and is a great place to forget about life for awhile." Such as the fact that diesel is \$9/gallon in Turkey!

to have it brought in by barge. We found the food in the tavernas to be excellent and, at less than \$50 for two, reasonably priced. Good house wine was usually less than \$10 per "kilo" (liter). That said, food in the grocery stores was more expensive than in Turkey due to higher transportation costs.

While the Med is very interesting from a historical standpoint, it is much more expensive and difficult cruising than in Southeast Asia or north Queensland in Australia. The Med is also very crowded with charter and tour boats, so it's almost impossible to find a quiet anchorage where you can be alone.

If I was looking for a place to cruise long term, my first choice would be Malaysia, where you can spend the season going down to Singapore and up to Thailand. Of course, north Queensland — home to the Whitsundays and the Great Barrier Reef — are also fantastic, so I could see spending a couple more

winters — northern summers — there if we keep the boat past one circumnavigation.

We plan to head out to Crete and visit the village where my grandfather was born. Then we'll sail back to Turkey and north to Istanbul. After that, we'll travel back across the Aegean to Thessalonika and south to Athens before heading through the Corinth Canal to the Ionian Sea. We plan to leave the boat in Dubrovnik, Croatia, for the winter.

— george 06/15/08

Readers — When you read about the costs of cruising in other parts of the world, you can't help but realize how lucky we West Coast sailors are, what with huge, diverse, inexpensive, and relatively uncrowded Mexico so close at hand.

Imagine Me And You — M/V Tom and Judy Blanford Great Help from Singlar (Santa Rosalia, Mexico)

We normally keep our boat in San Carlos on the east coast of the Sea of Cortez, but have spent the last five weeks on the Baja side. We were anchored at Sweet Pea on the inside of Isla San Marcos when we woke up one morning to discover that Brigand, our little tuff guy dog, was having seizures and couldn't walk. We immediately sought help on the Sonrisa Net. Janice, a retired vet tech, helped us as much as possible via the HF radio, but we also learned there was a vet in nearby Santa Rosalia.

So we beat feet to the Singlar Marina, where we took a slip and asked the office staff to call for a taxi. They wouldn't hear of it! They insisted on driving us and our very sick pooch to the vet. Carlos, one of the Singlar employees, drove us, in part because he's fluent in English and would stay with us in case there was a language issue at the vet. The entire Singlar staff has continued to be helpful and concerned about our dog.

We've heard some negative comments by fellow cruisers about the Singlar Marinas. If those complaints are accurate, they don't apply to the marina at Santa Rosalia. The folks here have been terrific, and everything is clean and well maintained. Incidentally, the Singlar facility in Santa Rosalia has power and water, a pool, wi-fi, an air conditioned room for cruisers, a fuel dock, and the staff is easy to get along with. The slip fees are about the same as Marina Real over on the San Carlos side, and probably less than at Marina San Carlos.

Singlar Santa Rosalia is a first class facility, and the staff made it easier for us to deal with an unpleasant situation.

When little Brigand, seen with Judy, fell ill, the staff at the Singlar Marina in Santa Rosalia rushed to help — and really cared.



IMAGINE YOU AND ME

CHANGES

— tom and judy 06/08/08

Tom and Judy — To the best of our knowledge, cruiser complaints with the Singlar facilities are mostly over pricing. Based on their somewhat extravagant but woefully under-utilized facilities at places such as Puerto Escondido and La Paz, Singlar still doesn't seem to understand the concept of market-based pricing. It would be in their best interest — and that of cruisers — if someone could explain it to them.

Lucky Star — Brent Swain 36 Tim Sell, Shelagh and Leslie To Glacier Bay (Sausalito)

On May 20, the three of us, plus my dog Jack, left Juneau for Glacier Bay National Park and Preserve. I'd heard that we don't need a permit for the park prior to June 1, which is when most of the 300,000 annual visitors start to arrive on cruise ships. Speaking over the VHF, the folks at the Bartlett Cove Ranger Station confirmed we didn't need a permit. We departed Juneau on a bright and sunny day, and, except for just one day, would have the same weather for our entire trip. We're told that's almost unheard of in Southeast Alaska.

As we travelled up the Saginaw Channel, the humpback whales exploded up through the surface of the water, breaching frequently. We spent our first night at the public dock at the native village of Hoonah. After topping off the fuel tanks, we covered the last few miles to the park, and along the way saw many sea otters feeding in very deep water. We stayed center channel when we finally entered Glacier Bay National Park, as the Rangers advised us that there would

The dramatic snow-capped peaks of Glacier Bay were proof positive that 'Lucky Star' was no longer on San Francisco Bay.



be less chance we'd disturb the feeding whales.

Boats are allowed a three-hour stay at the Barlett Cove docks so, after taking Jack for a walk, we anchored out, and the next morning went to the boater orientation session. While there, we met David Brewster, who had paddled his kayak from Juneau. He looked a little ragged, so I invited him to put his kayak atop ours and ride up the west arm with us. He agreed.

We had a nice sail up to Blue Mouse Cove, but once there, Shelagh and Dave seemed a little reluctant to take the kayaks ashore to go camping. It took a bit of tough love on my part to get them into their kayaks and headed for land. I can't imagine why they were hesitant. Shortly after they paddled into an inlet they were followed by a black bear. I suppose I would have felt pretty guilty if they'd been eaten.

But our kayakers did return in one piece, after which we headed up the west arm. We got about as far as Johns Hopkins Inlet before the ice became so thick that I didn't think it was prudent to continue. So we just sat in the sunshine and enjoyed lunch. We then had a leisurely sail — among bergie bits, no less — all the way to North Sandy Cove. The crew kept busting my balls to start the engine, but I was having a great time sailing — even though we were only doing three knots. "Fuck 'em," I thought to myself, they can make something to eat or go to sleep, but I'm sailing my boat.

The next morning Jack growled at something ashore. It was a moose. I then shuttled all of Shelagh and Dave's gear to the beach, as they were to kayak and camp through the Beardslee Islands and meet up with us at Bartlett Cove. Leslie and I sailed the boat over the south arm of Fingers Bay.

After meeting up in Bartlett Cove, we said good bye to Shelagh, who hitched over the hill to Gustavus to catch a flight to her home in Montana. And the next morning, after bidding farewell to Dave, we set out for Tenekee Hot Springs. Tenekee has about 100 residents, but there are no vehicles except a fire truck and fuel truck. Everyone walks, bikes, or rides an ATV. After two days of hanging out with friendly locals, tak-



ing hot soaks, and even a yoga class, we headed back to Juneau. We had a great sail across Icy Strait. In fact, I even had to reef the main. We pulled into Funter Bay for the night, but the public dock didn't have a ramp to shore. Jack found this to be very confusing.

The next day we got the whale show as we made the last few miles back to Juneau's downtown marina. My slip fee for this first-class marina is \$130 a month. Even so, many of the slips at this city harbor are empty. Why? Because they recently raised their rates, so the fishermen moved to Hoonah, where the slip fees are lower.

— tim 06/15/08

Tenacity — Pearson 424 Terry and Vicki Fahey A Whale of a Great Time (Richmond)

We've been cruising Mexico since last fall, and have enjoyed the abundant wildlife — including the breaching whale in the accompanying photograph. The whale made its appearance on March



TENACITY

The real world on display. *The Faheys took this beautiful photograph of a whale about 15 miles outside of Mazatlan.*

25 when we were about 15 miles out of Mazatlan and the ocean was as smooth as glass. I saw this little guy breaching, so we cut the engine and were entertained for a long time. I couldn't believe our luck! I also have some video of a mother and baby whale outside of Chacala — mostly fluke slapping — and we saw many mothers and baby humpbacks from Chacala to Mazatlan.

And once we got over to the Sea of Cortez, we found that the sea life is outrageous! We've seen many different types of fish, a lot of giant manta rays, a variety of sting rays, and much, much more. At San Juanico and Aqua Verde, we saw a number of osprey nests, and we've often seen lots of dolphins. In fact, we saw a group of dolphins at the bow of our dinghy on our way back from snorkeling. The animals, sea life, and clear water have made this part of our trip our favorite.

— terry and vicky 05/05/08

Cruise Notes:

"As far as I'm concerned, Norm Goldie in San Blas saved my finger," writes Ken Douglas, who usually singlehands his Astoria, Oregon, and Mazatlan-based Pearson 356 ketch **Mermaid**. "In February, I was stupid enough to check the V-drive with my hand, and for all practical purposes severed the end of my finger. Fortunately, I had a guest aboard who helped me reposition the end of the finger and stop the bleeding. Then I got on VHF 22 and asked if anyone in San Blas knew where there was medical help. Norm Goldie came on the radio and took over. He arranged for Ishmael, who owns a local restaurant and provides other services for cruisers, to meet me on the beach when I came ashore in my dinghy. While Ishmael drove, Norm contacted the Naval hospital to let them know that I was coming and the nature of my injury. Four hours after my initial call for assistance, the end of my finger had been reattached — with the warning that the doctor

would have to cut it off if it turned black. The cost for the treatment, including medication? Just \$7 U.S. I thank the sea spirits that Norm was in San Blas and had the connections to set up everything. Today, my finger works normally, and other than an ugly fingernail, is just great."

Speaking of San Blas, whatever happened to the **Singlar Marina** that was supposed to be built there? Norm Goldie reports that last year officials informed him that it would be operational for the '07-'08 season. That didn't happen, so now that they are promising it will be ready for the '08-'09 season, he's a little skeptical. "They are doing some work," he writes, "but they're going to have to speed things up if they want to be open for the next cruising season. For one thing, the amount of dredging that needs to be done is extensive. At present, 75% of the estuary entrance is dry, so I recommend skippers contact me before they attempt to enter."

In February, when would-be Pacific Puddle Jumper Sally Hein of the Bainbridge Island-based Peterson 46 **Grace** was run down and badly injured by a speeding motorcycle in Mexico, other sailors on the scene agreed that it was one of the most bizarre and unlucky incidents they'd ever seen. Ironically, only seconds before attempting to cross the highway Sally made the sarcastic comment, "We'll be lucky to get across this highway — let alone 3,000 miles of open ocean." The accident put Sally in a Puerto Vallarta hospital, where she endured several surgeries and faced a slow recovery. She insisted, however, that her husband, Geoff Lane, and a couple of friends make the crossing to French Polynesia without her, promising that she'd catch up when the sailors all got there. And she did, too. "We are **After Sally's recovery and Geoff's sail across the Pacific, the couple were reunited in French Polynesia aboard 'Grace'.**



LATITUDE/ANDY

CHANGES

thrilled to report that we're back together on *Grace*," wrote Geoff from Moorea. "While Sally still has an open wound on one leg, she is 90% recovered and is ecstatic to be back 'home'."

Beach clean-ups are popular in many populated sailing areas, but at remote Suvarrow Atoll in the Cook Islands? It's true. The folks at the World Cruising Club, who are in charge of the current **World ARC**, had gotten special permission for the 40 boats in the circumnavigating fleet to stop at the national park and wildlife sanctuary. As a thank you, the crews decided to work with warden John Samuels and his family to help clean up the damage done by winter storms. The two-day campaign saw fallen branches, battered huts, and piles of oceanic flotsam removed from the beaches and main campsite.

Of the three U.S.-based World ARC starters, the number is now down to two and will shortly be down to one. What's happened is that Jim and Mimi Logan of the Sarasota-based Outremer 55 cat **Candela**, who only were going to go as far as Australia, decided to drop out in



WORLD ARC

World ARC participants find that tattoos are good souvenirs, as they are light, don't break, and aren't subject to duty.

French Polynesia. And Don and Anne Myers of the Syracuse-based Amel Super Maramu 52 **Harmonie** decided they liked the South Pacific so much that they are going to stop in Australia, go back to the

South Pacific, then join the next World ARC when it comes through Cairns in '10. As such, Suzan Nettleship and Michael Bell aboard the Seattle-based Avatar 52 **Maamalni**, who at one point dropped three weeks behind the fleet, are the only Americans slated to go all the way around.

"As some *Latitude* readers might remember, while at Golfito, Costa Rica, about four years ago with my old Islander 37 *Viva!*, I had the 'pleasure' of a fer-de-lance snake coming aboard," writes Bob Willmann of the Golden, Colorado-based F/P Casamance 44 **Viva!** that was stretched to 47 feet. "The fer-de-lance is such a deadly snake that the Central Americans call it *Dos Peds*, or something like that, means 'two steps', which is supposedly about all you get before you die if a fer-de-lance gives you a good bite. It was a mystery to my friends and me how such a snake could have gotten aboard my boat, which was anchored in the middle of the bay at the time. But it did get aboard, and ended up coiled at the foot of my cockpit cushion. Well, it's





We help make
El Salvador
worth the trip!

Visit our Web site
www.barillasmarina.com
to learn more about our
many amenities including
high speed Internet,
on-site customs and
24-hour security.



Barillas Marina Club is the premier cruising destination in El Salvador. We are Located in Jiquilisco Bay, the largest Bay in El Salvador. Make Barillas Marina Club your headquarters in Central America and experience the difference that makes us a preferred destination.

www.barillasmarina.com
 (503) 2675-1131 • info@barillasmarina.com

LET MARINA EL CID
WELCOME YOU TO MAZATLAN!

Cruisers -
FIRST
NIGHT
FREE*



Official
Sponsor
2008
BAJA
HA-HA

A CRUISER'S PARADISE IN THE HEART OF MEXICO'S
LUSH TROPICAL COASTLINE AND BEAUTIFUL ISLANDS

A Full Service Marina Offers...

★ 90 slips from 25' to 120'	★ 24-hour security
★ Electrical and water hookups	★ 24-hour laundromat
★ Telephone connections	★ Supermarket
★ Restrooms and shower facilities	★ Dry dock
★ Dock Boxes	★ Gasoline - Diesel
★ Dock Carts	★ Pump-out station

NEW Marina-Wide High Speed Wireless Internet Connections!

www.elcid.com

011-52 (669) 916-3468 • gcevallos@elcid.com.mx

*Reserve for any multi-day stay and your first day is FREE!

Page 192 • *Latitude* 38 • July, 2008

four years later, I'm in Guatemala's Rio Dulce aboard my new *Viva!*, and what did I find yesterday when I removed the cockpit cushions? A barba amarilla, or yellow beard, which is a small and deadly snake known as *Tres Minutes* in these parts, because after a good bite you can expect to only live for another three minutes. If bitten by one, the U.S. Army's *Jungle Survival Handbook* recommends that you "lay down and try to make yourself comfortable." My little yellow beard was only about a foot long, and probably couldn't have opened his mouth enough to bite anything bigger than a little finger, but just the same, I'd rather it hung out someplace other than on my boat. But the same question arises, how did this one get on my boat? I haven't been tied up to shore or sailing beneath any trees. And why did it decide to get under the cushion where I always sit? Is there something about boats named *Viva!* that attracts deadly snakes? But the most important question is, where is the little snake's momma?"

(Because we're curious by nature,

we did a little research on Wikipedia, and discovered that the fer-de-lance and barba amarilla are two different names for the same venomous pit-viper species common to Central America. No matter what you call them, these snakes are large and nervous, and are usually responsible for the vast majority of snake bites in whatever area they inhabit. However, the 'two step' or 'three minute' names are exaggerations of the power of the venom. Prior to 1947 in Costa Rica, where it is considered the most dangerous snake, the fatality rate was about 7%, but now it's almost zero. If treated with dispatch, most victims survive.)

Willmann reports he's in the Rio Dulce



No matter if you call them fer-de-lance or barba amarilla, this type of snake irritates easily and is quick to bite. But most victims survive.

for the duration of hurricane season. "Having lost my original *Viva!*, as well as everything I owned, in a hurricane two years ago, I'm kinda touchy about being near them. But my semi-long-term plan is to spend another year or two in the Caribbean — meaning Honduras, Panama, the San Blas Islands, and Co-

YOUR SECRET PARADISE...



Located in a beautiful sheltered lagoon on the north Pacific coast of Nicaragua, Marina Puesta del Sol is your premier cruising destination in Central America

- ◆ Onsite Immigrations & Customs
- ◆ Full service restaurant and bar
- ◆ 24 hour security patrol
- ◆ Internet & Fax/copy service
- ◆ Yacht club with showers and laundry



- ◆ 140 foot fuel dock - diesel/gasoline
- ◆ Well marked channel
- ◆ 40 slips with water, power and cable TV
- ◆ Two pools, oceanside and marina
- ◆ Tennis, surfing, fishing, horseback riding
- ◆ Luxurious hotel with 19 executive suites



Marina Puesta del Sol

Aserradores, Nicaragua • 011 (from US and Canada) 505-883-0781 mpuestadelsol@yahoo.com • www.marinapuestadelsol.com • USA 408-588-0017

...IN BEAUTIFUL NICARAGUA

CHANGES

lombia — then do another Canal transit and climb back up the coast of the Pacific to Mexico." What's Willmann think of his 47-ft catamaran after so many years cruising on an Islander 37? "Sometimes she's too big for a singlehander like me, but nobody ever has too much space on a cruising boat. I've already put 6,500 Caribbean and ICW miles under her keels, so I'm still just getting to know her, but I flat out love her! In fact, I wonder if any catamaran owner has ever gone back to a monohull?"

"Life has been good down here at **Puerto Los Cabos**," reports Marina Manager Jim Elfers. "We've had remarkably moderate weather for June so far, with San Diego-like air temps, but the water is now up to nearly 80 degrees. As for the Puerto Los Cabos Marina, which as most folks know is located at San Jose del Cabo, 17 miles to the northeast of Cabo, we've just opened up a dock of 70-ft slips, all of which were leased out a year prior to the opening. That means we're up to 90 slips, with another 60 that will be coming on soon, and several hundred more later on. I can also report that we've signed a major deal with The



LATTUDE/RICHARD

Puerto Los Cabos Marina Manager Jim Elfers, gesturing to the historic breakwater, says more berths are coming online all the time.

Marine Group of San Diego, so we'll be getting a 150-ton Travel-Lift and a real chandlery. The fishing has been good, but not wide open. We have some Ensenada and Mazatlan-based tuna

boats setting nets right off our coastline — and it's perfectly legal! Having fished out their own waters, now they are going after ours. We're fighting them, of course, but haven't won yet. But at least this is circle rather than gill net fishing, so they aren't a big hazard to navigation."

"Weather guru Don Anderson of **Summer Passage** got on the Amigo Net this morning and reported that the Pacific Seafarer's Net (PAS) was complaining that the Puddle Jump bunch "didn't know what they were doing," writes Puddle Jumper John Hallinan of the Seward, Alaska-based Southern Cross 39 **Horizons**. "It seems that the 'rules' for the various nets vary considerably, with the Pacific Seafarer's Net being a bit more structured and formal than most of the others. As I understood the complaint, Puddle Jumpers would neither pre-register with the net nor would they give a day's notice before departure — both of which are apparently requirements — and would just call in. Another complaint was that Puddle Jumpers would sometimes miss a roll call, breaking another rule, which

OPEQUIMAR

MARINE CENTER CENTRO MARINO

**88-ton (max)
Travelift!
Length to 100'
Width to 23'**

Official Sponsor
**2008
BAJA
HA-HA**

Puerto Vallarta, Jalisco, Mexico
Paseo de la Marina Sur #214 • Marina Vallarta, 48354
Tel: 011 52 (322) 221 1800 Fax: 011 52 (322) 221 1978
email: info@opequimar.com

Visit Our
Yacht Club!

Opequimar Yacht Club

First Class • Full Service
On site dining, Internet, socials

BOAT SALES
NEW & USED BROKERAGE

www.opequimar.com

West Marine
We make boating more fun!

SIMRAD
A KONGSBERG Company

PETTIT
marine paint

Come to Mexico,
Enjoy the Mexican Riviera,
Repair your boat at
OPEQUIMAR

would then trigger a time-consuming 'health and welfare' action by the Pacific Seafarers Net. Frankly, the rules of engagement and/or operating norms for these nets vary so much that they are a mystery to newcomers, including me. I haven't used the Pacific Seafarer's Nets, but now that I understand their rules, I probably won't in the future. It's way too easy to miss a roll call when you're sailing shorthanded, and who wants to get in 'trouble' for something like that? Maybe *Latitude* could do a piece on the most popular nets, noting their functions, rules, commitments, norms, and expectations."

No matter if they are on HF or VHF, all nets have different cultures, and they vary even more depending on who happens to be net control at the time. We list the most popular nets and a description of them in our *First Timer's Cruising Guide to Mexico*, and will do it again with this fall's reprint of our *Idiot's Guide to SSB Radio*. But when it comes to understanding the cultures and rules of the various nets, there is no substitute for listening in for a few

days in advance to decide if it's your style. Some nets are very rule-bound and orderly, while others are casual. On some nets people blab on forever about what seems like nothing to most people, while on others it's much more all-business. The beauty of the SSB and VHF radio is that if you and your friends can't find a net to your liking, it's simple and free to start your own.

The **margarita indicator** tells all! It's been about four years since we last stopped at the Chacala anchorage, which is about 34 miles north of Banderas Bay. When we did, we were shocked to find that none of the palapa restaurants served margaritas. If you wanted alcohol, it was beer or nothing. So when John and Gilly Foy told us they were headed that way with their Alameda-based *Catalina 42 Destiny* in May, we warned them. We



John, Gilly, Louis, and Laura agree that margaritas really are available in Chacala now. It's another village on the march upscale.

need not have.

"We can report that margaritas are now readily available at Chacala — and even have photographic evidence," write John and Gilly. "Like many other ocean-front locations in Mexico, Chacala is moving more upscale, so mixed drinks are now available in many places. We

Puerto Lucia, the gate to the South Pacific

www.puertolucia.com.ec

2900 miles to Marquesas Island

Galapagos At only 500 miles from Puerto Lucia

2.13 S 80.55 W

North Atlantic Ocean

Panama Canal

Dona Juana

50-ton Travelift
Long and short term dry storage. Maintenance and provisioning.

Ecuador has the Best Climate in the World

(Source: International Living, January 2005)

Excellent climate year round, floating docks, fuel, laundry, Mediterranean-style moorings, Wi-Fi, Cruiser's Lounge electric and water hook-ups.

South Pacific Ocean

For Further information: 593-4-2783190 / 593-4-2206154 or email us: marina@puertolucia.com.ec, www.puertolucia.com.ec

CHANGES

enjoyed an easy daysail from Punta Mita to Chacala, as the jungle-covered Nayarit coastline is spectacular. The Chacala anchorage can be a bit rolly, but setting a stern anchor helps, especially when the onshore breeze dies in the evening. While in Chacala, we met up with Louis Kruk and Laura Willerton of the Alameda-based Beneteau 42s7 **Cirque**, who had just made an overnight passage down from Mazatlan. *Cirque* was just back in the water and looking good after being hauled out at the relatively new Singlar facility in Mazatlan where, in addition to other work, she had her bottom sprayed. Kruk was very pleased with the quality, cost, and efficiency of the job. We're planning to haul *Destiny* there next year while on our way to Sea of Cortez Sailing Week and cruising in the Sea of Cortez."

"We're home safe and sound after a season in which we logged over 3,500 miles in Mexico and made many new friends," report Chuck and Elaine Vanderboom of the Lake Havasu City, Arizona-based Corsair 31 catamaran **Boomerang**. "We would like to thank the



LATITUDE/RICHARD

Having covered 3,500 miles in Mexico last season, Chuck and Elaine proved you can have big runs with a relatively small trimaran.

Grand Poobah for the great '07 Ha-Ha, and *Latitude* for reviving Sea of Cortez Sailing Week — and for the fantastic write-up on us and our boat in the May issue. We had one friend jokingly

ask us to autograph his copy. If all goes well next year, we hope to sail down from San Carlos to participate in Sea of Cortez Sailing Week again."

"We've been enjoying the Ixtapa-Zihuatanejo area since our arrival two weeks ago," reports Lesa Pyle of the Brookings, Oregon-based Gulfstar 41 **Someday**. "Lately one possible answer to the pet overpopulation problem has been floating through Marina Ixtapa. He's a very large — 10-ft or so, but who has a tape measure? — croc. I keep Perra Bonita, my dog, on a very short leash here."

Crocs aren't new at Marina Ixtapa. We can remember being there 20 or so years ago when they were building it, and one worker would be in the water pounding on pilings while another worker would be stationed on the dock near him with a baseball bat. When we asked what it was all about, the guy with a bat pointed to a sign warning of crocs. The thing we still don't understand is why there aren't more croc attacks on humans in Mexico. After all, there are countless



Blue Sky
ENERGY

Increase Your Solar Output With Solar Boost™ MPPT Solar Charge Regulators

Get All The Power You Need To Weather Any Storm

The Solar Boost™ 3024i & 2000E are two of the most reliable Solar Charge Controllers on the market & our patented technology extracts all the power your solar panels can deliver, up to 30% more!

Blue Sky Energy Inc. gets rave reviews in *Practical Sailor*. Read the article at www.blueskyenergyinc.com

800-493-7877 or 760-597-1642
2598 Fortune Way, Suite K, Vista, CA 92081 USA
E-mail: sales@blueskyenergyinc.com
Web: blueskyenergyinc.com

QUALITY....RELIABILITY....BLUE SKY ENERGY, CHANGING THE WAY SOLAR IS USED EVERYDAY





large ones in the lagoons all along the mainland coast of Mexico. Near San Blas, you can even 'swim with crocs' just like you can swim with dolphins in other places. And at very busy Paradise Marina, 12-ft+ crocs cruise the waters all the time, but for some reason have yet to eat any of the divers who scrub bottoms or the fishermen who stand knee-deep in the water all day and half the night fishing with nets. A three-year-old local child was snatched and killed by a croc about a year ago on the south shore of Banderas Bay, but in 30 years that's the only croc-on-human attack we've heard of in Mexico. One explanation is that crocs like the taste of dogs and cats, but not human flesh. Another is that there is so much food around they don't need to attack humans.

"I want everyone to know that some of the booty gathered at last December's **Banderas Bay Blast / Pirates for Pupils Spinnaker Cup for Charity** is in a safe place," reports Ronnie 'Tea Lady' of Banderas Bay. "I delivered a car full of supplies to a school for children at Punta

Mita recently. Unfortunately, the accompanying photo doesn't do it justice, as it was taken by a very insistent three-year-old. But in addition to stationery, paints, jigsaw puzzles and balls, we also delivered interlocking rubber mats, which are ideal for when the kids need to participate in floor-based activities. I also took three large boxes of medical supplies to the local health clinic — much to the astonishment of the new doctor, who looks to be all of 10 years old! I took an equal amount of booty to the special needs school in PTL, the suburb of Puerto Vallarta, together



Several students and Ronnie 'Tea Lady' stand with some of the booty from the Banderas Bay Blast and Pirates for Pupils Spinnaker Run.

with some soft squashy toys to encourage tactile response. The appreciation of all the teachers was overwhelming, and, on their behalf, many thanks to everyone who contributed. I'll be making a similar delivery when the schools go back in session after the summer break. After that,



Since 1987

SPARKLING FRESH WATER, POWER, AND REFRIGERATION FROM THE SEVEN SEAS

110 VOLT / BELT DRIVE



HYDRAULIC



MODULAR KIT



UPGRADE MOUNT



316 S/S REMOTE PANEL



12 VOLT DC



AquaGen combines the quality, simplicity & reliability of AquaMarine, Inc. watermakers with the durability of the Kubota 150 amp 12V diesel generators. This compact low fuel consuming AquaGen is a powerhouse, capable of producing up to 150 amps, and 8 up to 62 GPH of fresh potable water from any water source. Make fresh water, refrigeration, and also charge your batteries all at the same time! A hydraulic pump may also be added to run your dive compressor, windless, bow thruster, or emergency bilge pump. Ideal for longterm cruisers or weekend wanderers. We custom engineer our systems to fit any size vessel or cabin site. Electric, Hydraulic, or Belt Driven Modular Kits are also available. Visit our Website for more information.

QUALITY AT AFFORDABLE PRICES.
LIFETIME WARRANTY ON PUMP HEAD AND PRESSURE VESSELS.

AquaMarine, Inc., 58 Fawn Lane (P.O. Box 55) Deer Harbor, WA 98243 USA
(800)or(360) 376-3091 Fax (360) 376-3243

www.aquamarineinc.net



Colligo Marine™

Affordable
Synthetic Shrouds
Featuring Dynex Dux™
Low Stretch, Low Creep,
12 Strand Line.



Emergency Shroud Kit

- Easily Stowable
- Easily Installed
- No Corrosion

480.703.3675

Colligomarine.com

CHANGES

there won't be much left in the pirates' chest. For folks coming down on the Ha-Ha or by themselves, what's needed most — in addition to copious doubloons — are writing instruments and paper. It doesn't need to be fancy, and you can often pick up back-to-school bargains in chain or thrift stores. Finished with reading glasses, hearing aids, crutches, or anything in braille? All of that can be put to good use down here also."

As a reminder, this year's Banderas Bay Blast — the 'nothing serious' three-day cruisers regatta on Banderas Bay — will be held on December 3, 4, and 5, ending up at Paradise Marina and the Vallarta YC just in time for the December 6 Chili Cook-Off. The three legs of the Blast are: seven miles from Nuevo Vallarta to the Nayarit Riviera Marina, where there will be live music and extreme socializing at Philo's Music Studio in La Cruz; ten miles from the Nayarit Riviera Marina to Punta Mita, where the Punta Mita Yacht & Surf Club will again open for the year with margaritas, music, and other fun and games; and finally, the classic Pirates for Pupils Spinnaker Run



LATITUDE/RICHARD

The Banderas Bay Blast has been carefully scheduled this year so nobody has to miss the Vallarta YC's Chili Cook-Off in December.

for Charity part of the Blast, which is 12 miles under spinnaker from Punta Mita to Paradise Marina. Ronnie 'Tea Lady' reminds everyone to bring pirate attire — which is *de rigueur* for the Pirates for

Pupils — as that kind of kit is hard to find in Mexico.

Here's a funny one. If you go to Google Earth — which is a terrific and free tool — and zoom in just to the east of Punta Mita, you'll see they have some camera sites. If you click on them, you get photographs of the area. We clicked one not far from the *panga* marina there — and saw a photo of last year's Banderas Bay Blast, with *Profligate* and *Capricorn Cat* with their chutes up. Check it out!

Mexico marches on! Thanks to Mexican President Felipe Calderon signing a long-awaited constitutional amendment, Mexico now presumes that all crime suspects are innocent until proven guilty, and will begin having U.S.-style public trials. Until now, a judge would make a ruling behind closed doors based on written evidence. Alas, it's expected to take years to train judges and lawyers to be able to conduct the new style trials, so full implementation is not expected until 2016. In other news from down south, Mexico has announced price controls on 150 basic foodstuffs in an attempt to

Toll Free 1 866 365 25 62
01152 646 155 41 06
info@marinapuertosalina.com



*Marina
Puerto Salina*

Marina Services:
Power 220 / 110 volts
Internet
Fresh water
Security 24 hrs
Cleaning
Dock master
Showers
Dressing room
Laundry
Immigration

Shuttle to :
Ensenada & US border
Pump out
Restaurant & Bar
Yacht Club
Dry Dock
14 ft depth at low tide
(channel access)

Lat. N 32° 3.28'
Long. W 116° 53.20'
Ensenada 27 NM south
Tijuana 39 NM North

New Slips Available 30 to 60 ft.
\$.55cts daily \$11.55 monthly \$9.35 & \$8.50 long term per ft per month.

www.marinapuertosalina.com

curb rising food prices. While overall inflation isn't terrible in Mexico, food prices have risen 8% in the last 12 months, which is dangerous in a country where so many poor people have to spend most of their money on food. Mexico already has a cap on the prices of diesel, which sells for \$2.01/gallon — or less than half of what it does in the United States. Price freezes have historically proven to be risky, as they often just postpone problems and frequently make them even worse.

"After getting our boat to Seattle the easy way — on the back of a truck — we ran into the worst January weather on record," write Angie and Peter Rowland of the Richmond-based sloop **Casablanca**. "It was two weeks of cold, nasty, windy, rainy weather that even had the Seattleites complaining. We should have known when we pulled into our slip, as the boat next to ours was **Rain Cloud Billy**. But once the seasons changed and we got off the dock, we had three days of motoring north in flat water with just a little breeze on the nose. Finally, after

reaching Smugglers Cove on the Sunshine Coast, we got to enjoy our first real sunset. The next day, the sun came out and the wind was at our backs. We reached all the way up past Jervis Inlet to the Powell River. As we write this, it's raining again, but we should make Melanie Cove in Desolation Sound by sunset. We also just picked up our fishing licenses and are ready to catch some salmon. The favorite rig here is Purple Haze Flasher and Hoochies."

Not to be smart-asses, but we can't wait for an explanation of why you would truck your boat to Seattle in January as



It turns out that verdant Smuggler's Cove, British Columbia, doesn't look that much like Richmond after all.

opposed to April.

Also headed north this spring, and all the way to Alaska, are Dick and Sharon Drechsler of the Long Beach-based Catalina 470 **Last Resort**. "After a number of very pleasant visits to many of the Bay's fine yacht clubs earlier this year, Dick and I had probably overstayed our

Your Boatyard in the Heart of Paradise



Large, fenced, secure dry storage area

Tahiti Customs policy has changed!
Foreign Flag vessels can stay on dry storage in our yard for up to 12 months out of 24.



A Subsidiary of
The Moorings Yacht Charter, Ltd.

Our Services |

HAULOUT

- Marine Travelift 25 tons
- Marine railway 120 tons
- Storage in adjustable steel cradles
- Fenced Yard

PAINTING

- Topsides, hull, bottom, varnish
- Brush, roller, spray

MECHANICAL WORK

- Inboard, outboard, diesel, gas
- All brands

REPAIRS

- Electrical repairs
- Refrigeration installation & repair
- Fiberglass & woodwork
- Welding, steel, stainless, aluminum

SAIL LOFT

- Sail repairs, biminis, dodgers, covers

STORE

- International, Pettit, Epiglass, Devoe
- Spares
- Fill U.S. gas cylinders

DO-IT-YOURSELFERS WELCOME!

BoatUS Cooperating Marina



Professional boatyard in the heart of Paradise

Raiatea Carenage will make sure paradise is everything you expected.

Call, write, or sail in . . . we're here to serve you.

B.P. 1111 Uturoa Raiatea 98 735 Polynésie Française

Tel: (689) 600-545 ~ Fax: (689) 600-546 ~ VHF 68

Web site: <http://www.raiatea.com/carenage> ~ email: raiataecarenage@mail.pf

CHANGES

welcome. But with him finally making it back to the Bay after leaving aboard his Catalina 36 in '97, reunions with lots of old friends were in order. But wanderlust got the better of us on April 22, when we waved goodbye to friends at the St. Francis YC and headed north."

According to Google Earth, it's 315 miles from San Francisco to the Oregon border, the coast of Oregon is 290 miles long, and the coast of Washington, before turning east at Cape Flattery, is 150 miles from the Oregon border. The wind and seas were naturally on the nose for the Drechsler's trip, but it wasn't too bad, nor were the bar crossings at harbors along the way. Crab pots were an issue. The couple say the "crab pot-free lanes," claimed by some cruising guides, simply don't exist and, in fact, they got one crab pot line caught in their prop. Their other big excitement was when their dripless shaft bearing had a problem, allowing seawater inside the boat and setting off the high water alarm. But they survived and, as we write this, have made it to Alaska.

"We are currently moored at Puerto



LAST RESORT

Dick and Sharon spotted their first bald eagle at Poet's Cove, Bedwell Harbor. On their way to Alaska, they've seen many more.

Amistad YC at Bahia Caraquez, Ecuador," report George, Melinda, and seven-year-old Joshua Salley of the Newport Beach-based F/P 42 catamaran **Southern Belle**. "As some *Latitude* read-

ers might be aware, Puerto Amistad has been getting some bad press lately due to certain political issues. We can't speak to those issues, but we can report that the facility and services here are very nice for the price, which is currently \$270/month for the moorings and use of the facilities. Puerto Amistad has an elegant and picturesque restaurant built over the water, and there is free wi-fi at the bar. Paying a lot for fuel in the States? It's only \$1.50/gallon pumped into your boat here. Laundry is 35 cents/pound. The showers and bathrooms are beautiful, there's a work area for boat projects, and the courteous and friendly staff make you feel like part of the family. We hope the political mess works itself out so everyone can get along, but meanwhile, we give Puerto Amistad a big thumbs up!

Cruising is not all smooth seas and cocktails at sunset. Here's an excerpt from the most recent report from Liz Clark of the Santa Barbara-based Cal 40 **Swell**, whose most recent passage on her surfing safari under sail took her from Fanning Island to Bora Bora:

MARINA REAL

SAN CARLOS, SONORA, MEXICO

IN THE SEA OF CORTEZ
 Located on the Mexican mainland near Guaymas and San Carlos, 265 miles south of Nogales, Arizona.

- 350 slip marina • 20 & 30 amps electrical service
- 24-hour security patrol
- Fuel dock with gasoline/diesel
- Restrooms & showers
- Web email • Fax/copy service
- Port entry clearance
- Book exchange • Video loan library
- Ice & bottled water
- Wet storage for summer months (low prices)

Now Offering:
Haulouts, Dry Storage & Service Yard



Phone/fax 011-52-622-2270011
 Call on VHF #16 when in area
 email: marinareal@prodigy.net.mx
 Visit our website:
www.marinareal.bravehost.com



HYDROVANE
SINCE 1968

Celebrating 40 Years of Excellence

Survive Your Dream

'Great Atlantic Gear Test'

Always rated #1 or #2!

Courtesy Jimmy Cornell



THE JOURNAL OF YACHTING MONTHLY October 2006

100

best bits of gear - ever!

HYDROVANE included twice!

Hydrovane is both:

- ★ Self Steering
- ★ BEST Emergency Rudder

SHOWERS EVERY DAY!

ECH₂O Tec Watermakers

BUILT TO LAST

www.hydrovane-watermakers.com

www.hydrovane.com
604-925-2660
info@hydrovane.com

"In another instant, the monster hit *Swell* and me with the swiftest, fiercest blast of wind we've ever felt. *Swell* is pinned on her starboard side. I frantically release the mainsheet and my boat comes up after the impact of the initial blow. I cry out for my father, but he can't hear me. No one can hear me. Now comes rain. But this isn't rain, it's a sky of water. It's so intense that the sound is deafening. The wind subsides as it moves over us. My body trembles out of control. I bite my lip and can taste blood in my mouth. The lightning repeatedly casts its white electric light to remind me that this moment is real. The monster pursues despite the fact I have *Swell's* engine at full throttle trying to get away. I gather my composure and squint into the clearing night sky. A small patch of stars ahead hints of hope. More lightening flashes a few miles ahead. Tears flow down my cheeks but I make no noise of crying. I just strain to see what's ahead. I look at my watch, and it's only 10 p.m. The night has just begun."

Similarly, the start of Liz's very long

and rough passage had only just begun. We'll have more next month.

It's a little premature to conclude that global warming caused all the **unusually warm weather** in the West — and on San Francisco Bay — the first two weeks in June, but it was cooking. Down in Southern California, the coastal towns are known for the 'June gloom' and often having June temperatures that are lower than in San Francisco. But it was a nearly gloomless June for the mainland coast of Southern California — and even Catalina, which is known for even cooler Junes. When Doña de Mallorca, after days of 85 degree weather on the hook by Bird Island,



It was so warm out at Catalina in June that folks could be excused for thinking it was August or September, the normal hot months.

asked the folks at the Two Harbors office how this June's weather compared with that of previous years, the response was unequivocal. "Weatherwise, this has been the best June ever!" Now, if they could just do something about the water temps.

Baja Ha-Ha Cruiser's Special August - October 2008 - 30% Off!

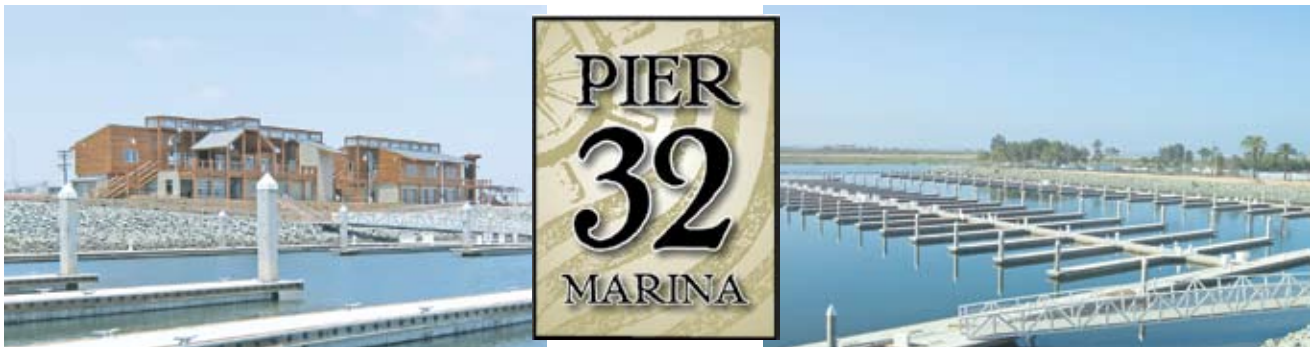

Yes, we're open! We welcome members of the 2008 Baja Ha-Ha Rally to San Diego!

Pier 32 Marina is the most beautifully developed marina in San Diego Bay with ultra modern docks and fabulous shoreside amenities including:

- 28' - 60' slips
- Deluxe shower rooms
- Spacious laundry facilities
- Exercise/workout center
- Swimming pool & Jacuzzi
- Boater's lounge
- High Speed Internet
- Free shuttle to trolley station
- Putting green

Ideal location for cruiser outfitting, provisioning and boatyard maintenance



Official Sponsor
2008
BAJA
HA-HA

Pier 32 Marina

3201 Marina Way
National City CA 91950
Call 800-729-7547

We are located just 6 minutes south of downtown San Diego at the mouth of the Sweetwater Channel as it enters into San Diego Bay.
office@pier32marina.com
www.pier32marina.com

Please read before submitting ad

CLASSIFIEDS

1. Write your ad. Describe what you're selling. Indicate category. Don't forget price and contact info. Be neat. We aren't responsible for errors due to illegible writing or unclear meaning. We make final placement determination.

2. Count the words. Anything with a space before and after counts as one word (eg. phone number, email address, price). We'll spell-check, edit and abbreviate, as necessary.

3. Mail your ad. Enclose check or money order, or deliver to our office with cash, or ...

Post your ad safely online with Visa, MasterCard or AmEx at: www.latitude38.com

Personal Ads

1-40 Words: \$40
41-80 Words: \$65
81-120 Words: \$90
Photo \$30

- Personal Advertising Only
- No business or promo ads except Non-Profit, Job Op, Business Op

Business Ads

\$70 for 40 Words Max
• All promotional advertising
• 1 boat per broker per issue
• Camera-ready art OK
• No photos or reversals
• No Extra Bold type
• Not to exceed 12 pt font
• Artwork subject to editor approval.

'Trying to Locate' Ads

Searching for People: \$10 for 20 Words Max

All ads will be set to fit *Latitude 38* standard.
Re-Run Ads: Same price, Same deadline.

Mail (or bring) to:

Latitude 38

Attn: Classified Dept

15 Locust Ave, Mill Valley, CA 94941

Questions?: (415) 383-8200, ext 104 • class@latitude38.com

DEADLINE

is always the

18th at 5 pm

of the month prior to publication.

Due to our short lead time, deadlines are *very strict* and include weekends & holidays.

- No ads without payments
- No billing arrangements
- No ads accepted by phone or fax
- No verification of receipt
- We reserve the right to refuse poor quality photos or illegible ads.

DINGHIES, LIFERAFTS AND ROWBOATS

10-FT TRINKA ROWING DINGHY with cover. Excellent condition. Located in Milpitas. \$1,500/obo. (408) 263-5837.

WEST MARINE/ZODIAK DINGHY, RU 260. New in Fall, 2006. Used just a few times, still like new. Comes with good running Evinrude 4-hp ob. In Alameda. \$700 for both. Call Jay (209) 617-1384.

24 FEET & UNDER

J/24, US 2155 with trailer. All new rigging from bare hull up. Also all new sheets, halyards, etc. New painted interior, full set new Quantum racing sails (valued at \$6,000). No bottom paint, very fast, all racing accessories. Available Stockton. Do the math, \$7,500/firm. Ray Lopez (209) 772-9695.

LIDO 14, SERIES 6000. Purchased new in 1997 but is in excellent condition, only sailed about 15-20 times. Owner never had the time to learn to sail. Cover is included. \$4,750. Also, wanted: used Sunfish in good condition. (415) 789-9143 azitaraji@yahoo.com.

CATALINA 22, 1981. SWING KEEL, pop-top. Includes main, jib, new halyard kit. 6-hp Evinrude, Porta-Potti, anchor. Hull and teak trim excellent; bulkhead-mounted compass. Trailrite with spare, new tires. Dry stored, Redding. \$4,300. Gary (530) 222-3823 or (805) 689-7913 (cell).

24-FT WYLIE WABBIT, HULL #51. Race ready, galvanized trailer, lots of gear. \$4,300. You pick up in San Diego. Call (619) 741-6989 (pm).



SAN JUAN 24, 1981 with trailer. New interior, main, genoa, jib and 2 spinnakers, 8-hp 2002 Yamaha 4-stroke electric-start, electric-tilt motor. Sleeps 5, includes galley and Porta-Potti, stereo/CD/MP3/XM radio and speakers. \$7,500. Call Toran (916) 708-4700.

1984 FREEDOM 21 BY PEARSON with unstayed carbon fiber mast. A solid 4-berth sailboat, needs TLC and a new spinnaker. Presently moored on Tomales Bay, must be moved. \$3,000/obo. (415) 669-7100 or tgaman@forestdata.com. Photos at: www.forestdata.com/freedom21.html

23-FT DEHLER SPRINTA SPORT. New-new carbon/Kevlar race sails, Ballenger mast and boom, great for singlehanded, 3-hp Mercury outboard, transferable Berkeley Marina slip. \$3,000. More info: <http://www.flickr.com/photos/branliw/sets/72157605660242505/> Call (925) 980-1727 or email: branliw@hotmail.com.



J/24, 1980. Maintained and ready to sail with main, genoa, roller furling jib. 9.9-hp XL-shaft 4-stroke electric Star motor with heavy-duty bracket. New battery and bottom paint 11/05. \$5,500 with motor. \$4,500 without motor. Trailer also available. Call Randy (530) 713-9964.

SANTANA 22. Race ready. Excellent condition. Low hours on Pineapple main and class jib. North 150 and oversized spinnaker. Also, 80% headsail. Faired keel, rudder and bottom. Just painted bottom and topsides. 3.5-hp Nissan longshaft recently serviced. \$3,200. (415) 686-5256.

BEAR BOAT #52, 1949. \$10,000 or best offer to secure a good home for *Juno*. 90% restored, but now needs regular maintenance. Restoration included keel bolts, sistered ribs, refastened hull, new deck structure, new cabin, new deck glassed, canvas, and sanded, new boom, original hardware. In need of paint and varnish, decent sails: 1 main 2 jibs, old and new spinnakers. Terrific upwind Sausalito Yacht Harbor berth. Call Bruce (415) 581-2617.

J/24, 1978 with dual-axle trailer. At Vallejo Yacht Club. Asking \$4,000. David Britt: rdbritt@ucdavis.edu or (530) 400-9142.

16.5-FT INTERNATIONAL 505. High performance racing dinghy. Parker (UK) wood foredeck and CB trunk. Fully ready to race. All new running rigging. 2 sets sails, excellent trailer. New tall Ullman spinnaker, still in box. \$5,500/firm. Ray Lopez, PO Box 16, Burson, CA 95225. (209) 772-9695.

SAN JUAN 24, 1977. Slow Dancer. MORA, MYCO, BAMA Doublehanded Race winner. Rigged for racing but excellent family cruiser. Numerous sails and equipment, including Autohelm, 3.5-hp Nissan ob and electronics. Priced \$3,000/obo. RYC. Dennis (707) 745-2529.

J/24, 1984. Professionally maintained and comes complete with main, genoa, jib and 6-hp motor. Many upgrades including new boom in 2005, new standing rigging and battery in 2006 and new winches in 2007. \$5,000/obo. Call (510) 843-4200, Matt or Phil.



MELGES 24, #331. Go, Dogs, Go. Lots of sails: 4 mains, 4 jibs, 4 kites and a full set of 1 regatta sails available (4 sails). Nissan 2-stroke, (Honda 4-stroke available). Velocitech, lots of new lines, new wire rigging, Hutchinson hiking pads, mast protector and rig adjuster system, updated cockpit hatch, spinnaker bag with hoop, newly reinforced stanchion bases, new traveler and traveler car, cockpit nonskid, deck and hull cover, trailer box, trailer brakes rebuilt with new actuator, new trailer tires and wheel bearing service 6/07. This boat is race ready, will deliver West Coast. \$32,000. Call Tim Hawkins (831) 234-2589, Santa Cruz.



Beautiful Cedar-Strip Row Boat

15'4" x 4'6" • Two fixed-seat rowing stations
Light and fast • \$6,800

John Tuma Boat Builder • (510) 366-1476

CHART SAVINGS UP TO 75%

HIGH DEFINITION PRINTS • 256 INCREDIBLE SHADES!

Worldwide • Sample Chart \$7.95 • Affordable E-Chart back-ups
Bellingham Chart Printers Division, TIDES END LTD., PO Box 397L, Shaw Island, WA 98286
800-643-3900 • fax: 360-468-3939 • www.tidesend.com • sales@tidesend.com

Specialists in Marine SSB radio and HF E-Mail

ICOM Marine Radios, Furuno, SCS/Pactor, McMurdo EPIRBs



HF RADIO ON BOARD

Communication is our Business!

www.hfradio.com
(510) 814-8888

WISE MARINE SERVICES

Refrigeration • Air Conditioning • Electrical • Engine Services
Experienced in both Power and Sail systems

Roger Wise • (510) 418-7550 • rdwisesr@gmail.com

25 TO 28 FEET

MacGREGOR 26M, 2005. Excellent condition. Trailer, 50-hp Evinrude E-Tec, 80 hours. Bottom painted 2005/08, dual batteries, 4 fuel tanks, furling jib, cockpit canopy, mainsail cover, 2 opening port windows. DVD/CD, 4-110v outlets, shore connection. Garmin GPS/depthfinder, safety equipment, Coast Guard radio, extras. \$22,500. Tony (510) 494-1749 or email: debtonjes@msn.com.

CAL 27, 1977. Must go. New boat on its way. Well maintained, good sails. Roller furler jib, tiller, diesel engine. A great Bay boat. Asking \$5,500/obo. Located in Richmond. Call (415) 690-9923.

EXPRESS 27 SAILBOAT WANTED. Would like to buy a good Express 27 with trailer to race against 'Mike' again. Prefer Northern California or nearby. Call (530) 318-3230 or rossgroelz@aol.com.

MacGREGOR 25 WITH TRAILER. Excellent boat, swing keel, new sails and covers. Newer 9.9-hp 4-stroke Mercury. New stereo, VHF, BBQ, stove, head. Pop-top with full wrap-around cover with windows. Sleeps 4. Much more. \$6,500. (530) 544-6234 or (530) 314-1694.



CHEOY LEE OFFSHORE 27, 1970. Classic fiberglass full-keel pocket cruiser. Original owner. Volvo 15-hp diesel, tiller, standing headroom. New bottom 2008. Beautiful, lots of teak, solid, needs TLC. Located Richmond YC. \$9,500/offer. Call (707) 763-9710 or email: stuart@lucky-duck.com.

OLSON 25, 1985. Freshwater. Pacific Boats Hull #63. Original gelcoat very slick, 2-axial trailer, 2 newer jibs and spin, North sails. 6-hp Johnson, KVH Sailcomp. Lewisville, TX. Asking \$11,500. Call Brian (469) 853-4158. <http://www.yachtworld.com/boats/1578513/0>

CATALINA 250 Mk II, 2005. Excellent condition. Wing keel, very low-hour Honda 8-hp electric start. Sheets led aft. Roller-furling 110% jib. Mast raising system. 12-gallon freshwater storage. CGN stove, stainless sink. Enclosed head with Porta-Potti and sink. Pop-up enclosure, GPS, speed, depth and fishfinder, VHF radio. Fortress anchor, 200-ft rode. Battery and charger, cockpit cushions, sail covers. Custom galvanized tandem trailer with brakes. \$28,000. mjbtcave@verizon.net or (510) 750-6553.

CAPE DORY 27, 1979. 155, 110, 90 and storm. Long-batten main with 2 reefs. Self-tailing winches. 2 anchors, 2 VHF radios, Loran, Autohelm, dodger, alcohol stove, gas BBQ. New standing rigging 4/05. \$6,700/firm. Craig (510) 278-2936.

YAMAHA 26, 1989. Yanmar diesel, roller furling, dodger, windvane, autopilot, solar panel, two deep-cycle batteries, inverter, GPS, VHF, AM/FM/CD, Bruce and Danforth anchors. Trans-Pacific veteran. Clean, dependable boat, gives you more sailing time. \$19,700/obo. (650) 728-5945 or nagayoshi@netzero.net.



MacGREGOR M-26, 1993. Sails, genoa, sail covers and bags. Cockpit cushions, pop-top enclosure. Mast-raising system. No motor. Trailer with new tires, wheel bearings re-packed 4/08. Excellent condition. Interior better than new. \$7,500. Call Roger (916) 663-1950 or email: rriley@lanset.com.

ISLANDER 26, 1971. Excellent Bay boat with tall cabin and roomy cockpit. Must see to appreciate the quality workmanship and solid construction. Sturdy boat in great shape. \$8,900/obo. Photos, movie(s) and details: <http://mytitle24.appspot.com/stellaforsale> Call (415) 864-4224 or ewalstad@gmail.com.

CHEOY LEE FRISCO FLYER, 1965. Perfect Bay cruiser in excellent condition. New sails, new full cover. Ballenger aluminum spar systems. 1990's Yanmar diesel engine. New batteries and charger. Fiber hull, teak deck, brightwork in great shape. Sausalito slip. \$12,000. (415) 992-1090 or niels.walther@comcast.net.



MacGREGOR 26X, 1999. On trailer. 50-hp Yamaha 4-stroke, Tahoe-legal. Furling jib, working jib, main, head, galley, sleeps four. Depthfinder, compass, marine radio. Great Bay and Lake boat. Asking \$17,500. Brian (415) 485-1958.

ISLANDER 28. Newer 20-hp diesel, many upgrades, clean and well-maintained. \$15,000. Call Bill (510) 846-1874 or email: floatinghouse@sbcglobal.net.

SANTANA 525, 1979 with trailer. Great family racer/cruiser. New sails, Nissan 6-hp 4-stroke, interior, 2-part poly paint, bottom paint, rope clutches, mainsail rig, boomkicker, etc. \$4,500. Trade for Japanese car possible. (928) 208-3822 or dabaker49@frontiernet.net.

CATALINA 25, 1981 POP-TOP. Fixed keel, standard rig, new main, 85 and 110 jibs plus whisker pole, new 8-hp longshaft ob, all lines run aft. Interior is clean. Transferable berth at Alameda Marina. \$6,500/obo. (510) 331-7614 or catalinapop25@yahoo.com.

BRISTOL 27, 1968. Near perfect. Atomic-4, good sails. New canvas, paint, varnish throughout. Great tackle. Channel Islands champion, sitting on mooring in Morro Bay. Sweet boat. Ready for memories. Will deliver South. \$9,500. (805) 235-2637. Photos? Email: ceccmil@charter.net.

MacGREGOR 26D, 1989. New Nissan 9.8-hp, 2007. New IdaSailor rudder 2008. Main, jib and genoa. Bottom painted epoxy 2008. One-year Santa Cruz North Harbor slip transferable. Trailer, Garmin GPS178C, Navman Wind3100, VHF. \$6,000. (831) 465-6714. Email for pictures: sergio.barberan@gmail.com.



CATALINA 27, 1979 with Atomic 4 inboard engine. Dependable engine runs strong. A fast, spacious, stable sailboat in excellent, well-maintained condition. Sleeps 5 with a beautiful teak interior. Nice sails. Berkeley slip. \$7,500. Jeff (916) 261-3440.

BAHAMA 25 (NOT ISLANDER). Looks like Folkboat. Stout pocket cruiser, easy motion, easy helm, points and tracks well. Full keel, cutaway forefoot, fractional rig sloop. Hand laid-up, overbuilt fiberglass hull and decks. Superb canvas (over \$5k). Complete aft enclosure formed by dodger, bimini and sunscreens. Also has full boat cover. Ballast 1,850 lbs. Displacement approx. 4,300 lbs. Bal/disl ratio 42.5%. Main, jib, drifter, VHF, bilge pump, Danforth. \$3,950. Lying Sausalito. Call (408) 799-2117 or email: yokj@yahoo.com.

INTERNATIONAL FOLKBOAT 26-FT Marieholm. OB, headsails, safety gear, radio, ground tackle, stove, sink, etc. See her on YouTube 'saving mr kitty'. Sitting in Newport Beach. Will deliver for reasonable expenses. \$4,800. Tom (415) 722-1407.

LANCER 28, 1981. Honda 10-hp 4-stroke ob. Shoal keel. Dry, well maintained, clean boat. Berthed in Alameda. \$3,500. (559) 260-6671.

CAL 2-27, 1974. \$8,000/obo. Inboard Atomic 4 gas engine. Mainsail, two jibs and spinnaker in good condition. Roomy with over 6' cabin headroom. Stable and very solidly built. Jamie (707) 267-5069 or email: humbelcola@yahoo.com.



HAWKFARM 28. Equipped for 2008 Singlehanded TransPac and offshore racing or fast cruising. Yanmar diesel, Monitor windvane, 160-watt solar, LED lights, newer mast, high-tech running rigging, Mylar and Kevlar headsails, 3 spinnakers, much more. No time for me to sail it back so see it in the Bay Area now, pick it up in Hawaii after the race. Ham radio, liferaft and other equipment negotiable. \$17,000 or possible trade. (510) 593-8697.

29 TO 31 FEET

PACIFIC SEACRAFT MARIAH, 1979. LOD 31', LOA 36', LWL 25', beam 10'9", draft 4'5", displacement 16,000 lbs, ballast 6,000 lbs. SA 596 sq ft, headroom 6'5". Fiberglass hull double-ender, full keel, cutaway forefoot. Wheel steering or emergency tiller. Staysail, roller furling foresail, fully battened mainsail. 30-hp Yanmar diesel, full service 12/07. Survey 12/07. New standing rigging 9/03. Bottom paint 4/07. Radar, GPS, VHF, SSB/Ham, Muir windlass, more. Loch Lomond Marina. \$69,000/obo. Richard (415) 927-2765.

KNARR #133. Completely re-done, new paint, teak decks, full race equipment, 3 mains, 4 jibs, full cover, fiberglass. \$38,000. Dewey Hines (415) 298-3565.

CATALINA 30, 1988. 21-hp diesel, low hours, dodger, bimini, autopilot, roller furling, new jib, new chartplotter, new battery charger. Excellent condition. Moss Landing slip. Call for details and photos. \$34,500. (831) 753-2001.

BUCCANEER 28.5 SLOOP. Trailer, center cockpit, wheel, positive flotation, diesel, Autohelm, depth gauge, GPS, roller reefing genoa, solar, swim platform, 6'2" headroom. 10'Avon with 3.3-hp Mercury ob. This is a fully equipped cruiser. Pictures and specs: <www.rhmarx.com> \$27,500. (928) 684-9606.

ISLANDER 30 Mk II. Atomic 4 engine, roller furling, singlehand rigging. Microwave and propane stoves, GPS. Wind, speed and depth. Sleeps 4-6. Expandable bunk to queen. New autopilot. Many extras. Must see \$12,000. Rich (415) 877-0011.

BOAT • LETTERING

alphaboatsue@aol.com • (510) 599-1197 • www.alphaboatgraphics.com

Creative and durable lettering and artwork for your boat

Marine Architecture

John Seward
105 Edison Ave.
Corte Madera, CA 94925
(415) 924-0429 • nims65@gmail.com

Marine Construction

Millerick Bros. Coast Marine
PO Box 357, Cotati, CA 94931
(707) 829-2507
(707) 823-1954 (fax)

Brochure Available

VOLPAR, Inc.

(408) 986-0848 • (800) 258-4545
Parts / Service • Penta Only
10am-7pm PST every day including Sat-Sun
email: Volpar@Volpar.com

VOLVO PENTA

WOODRUM MARINE

Specializing in custom interior
cabinetry, tables, cabinets, countertops,
cabinsoles. For power or sail.

CARPENTRY

Mobile cabinet shop
Contact Lon Woodrum at:

415-420-5970
www.woodrummarine.com

COAST MARINE

& INDUSTRIAL SUPPLY INC.

398 Jefferson St. San Francisco - On the Wharf.

Call **Bruce Becker** or **Clark Atkinson**
(415) 673-1923 (415) 516-4860

800-433-8050

Fax (415) 673-1927



LIFE RAFT
Sales & Service



U.S.C.G. Approved Testing Facility

- ★ U.S.C.G. life raft facility for Solas commercial yacht and fisherman rafts
- ★ COMAR DEBARKATION LADDERS
- ★ COMAR PILOT LADDERS
- ★ COMAR WORK LADDERS
- ★ All U.S.C.G. approved

GUINNESS WORLD RECORD "World's longest tested ladder 320ft."

Major Distributor for:

Pains Wessey
Safety Systems

STEARNS



IN SAN DIEGO CALL OCEANS WEST 619 544-1900

CATALINA 30, 1979. Alameda. Everything excellent. 2-speed self-tailing winches. Wheel steering. Lines aft. Excellent jiffy-reefed main, Harken roller jib. Rebuilt low-hour Yanmar diesel. Matching covers. Clean. One of the best, possibly the best Catalina 30 on the market. \$22,500/obo. (775) 527-0058.



NONSUCH 30, 1982 CLASSIC. Hard dodger, autopilot, anchor windlass, all-chain rode. 4-cyl Westerbeke with V-drive, 2,000 hours. Force 10 propane cabin heater, Paloma demand water heater. New aluminum propane tanks with crossover. Electric main halyard windlass. Propane stove with oven. New Sunbrella cabin cushions, vinyl cockpit cushions, interior refinished. Lee cloths, all berths and jacklines, new sail cover. Located Richmond, CA. \$49,000. (925) 934-1580 or dwheeler94598@hotmail.com.

GREY GOOSE, SF BIRD BOAT #10. Excellent condition. Top race record. \$9,000. (206) 780-2444.

CATALINA 30, 1978. Price reduction, original owner, new rig and Atomic 4 rebuilt 2003. New cushions, main, jib, genie, spinnaker, wheel steering, VHF, new wind instruments, depth, loads of other equipment, sound system, \$12,500, it's yours. New boat coming. (408) 210-6686.



CAL 30, 1963. CRUISE READY. Fully loaded for cruising or liveaboard. Comes with permanent slip in Santa Cruz Harbor. \$18,000/obo. Brand new: 185w solar panels, refrigeration, Lewmar windlass, Furuno radar, GPS chartplotter, Horizon depth/knot electronics. Custom hard dodger. Raymarine autopilot, Schaffer roller furling/130 headsail, new mainsail, spinnaker and sock, Volvo Penta MD2B diesel, electric tabernacle, new standing and running rigging, 3x to Mexico vet. LectraSan head, 2-burner stove, gas and charcoal BBQ, 1,000w inverter/charger, EPIRB, safety gear, tons of extra gear, solid fiberglass boat. Call John (831) 818-4161 or (831) 479-7678 or email for pics: jdeworken@hotmail.com.

J/29, 1984. Originally *Smokin' J*. Great Bay boat. Set up for shorthanded daysailing. Harken furling jib, lazyjacks, fractional rig, Yanmar inboard diesel. Racing gear off boat but available. Standing rigging replaced 2003. Sausalito berth. \$17,500. Email: timsalz@sbcglobal.net.

PT 30 Mk II, 1973. IOR 1/2-ton Britton Chance design. Great beginner, low maintenance performance boat, great cruising potential. 5 berths, standing headroom. Solid F/G hull, roller furler, diesel, VHF, D/S, W/P, W/S, K/M. 3 headsails, spinnaker, main. \$14,000/obo. Call (415) 279-0609.

CATALINA 30, 1982. Fully equipped and ready to go, just add water. New dodger, newer sails, canvas, GPS/chartplotter, roller furling. Refrigerator, h/c water, microwave. Second owner. Lying in Alameda. \$20,000/obo. Call Deborah (650) 714-7482 or dtinnca@yahoo.com.



CLASSIC BABA 30, 1982. Perry design rugged full-keel double-ended cutter. She'll take you around the Bay or around the world. Gorgeous teak interior with V-berth, head with shower, spacious salon with twin settees, butterfly hatch, hanging lockers, woodburning stove, full galley, nav station with quarterberth. LOA 30', beam 10'3", draft 4'9". 12,500 lbs with 5,000 ballast. Stainless fuel (35 gal) and water (75 gal) tanks. Hauled March 2008: bottom paint, major engine service on Volvo MD11D 27-hp diesel. Reconditioned main, jib, and staysail, new storm trysail and drifter. Roller furling on both headsails, bulletproof tiller steering, full cockpit enclosure, warm, dry winters. VHF, GPS, radar, WiFi, stereo. Downtown Sausalito view slip. Pictures available. \$57,900. (415) 332-6763 or cy@brainmon.com.

ISLANDER 30 Mk II, 1971. Great boat, clean. Newer diesel. Everything works. Strong hull, rigging, mast. New bottom paint, many electronics, dodger, oven, roller furling, etc. Transferable slip, Berkeley Marina. Call (415) 497-0398. \$15,000/obo. See website: <www.zoltanistvan.com/islander30.html>

CATALINA 30 SLOOP, 1981. Original owner, clean interior, new main and 90% jib. 24-hp Yanmar 3GM30F. Wheel steering, standing rig replaced 2001, dark brown trim. Located South Beach Harbor, SF. \$18,000. (415) 731-4956.



RICHARDSON BAY MARINA

formerly Kappas Marina

MODERN FACILITIES IN A WELL-PROTECTED HARBOR

Concrete Dock System

Well Maintained Facilities

Beautiful Surroundings

- DEEP WATER BERTHS: BASIN AND CHANNEL DREDGED
- CARD KEY SECURITY SYSTEM
- DOCK CARTS
- PUMP OUT STATION
- AMPLE PARKING
- CLEAN SHOWER AND TOILET FACILITIES
- WITHIN WALKING DISTANCE: MARKET/DELI, LAUNDROMAT, RESTAURANT
- AT EACH BERTH: LARGE STORAGE BOX, METERED ELECTRICITY, PHONE HOOKUPS, WATER

BERTH YOUR BOAT IN SAUSALITO

Phone 415 • 332 • 5510

100 Gate Six Road, Sausalito • Fax (415) 332-5812

Jack D. Scullion
Yacht Services

jdsyachts@att.net
(510) 919-0001

Rigging
Electronics
Troubleshooting
Electrical Installations



NOR-CAL COMPASS ADJUSTING

Magneuto™ System Exclusively
Boat Remains in Berth • Eliminates Deviation
Authorized Compass Repair • All Major Brands
Hal McCormack • Phone/Fax: (415) 892-7177

32 TO 35 FEET

THE FINEST RESTORED COLUMBIA 5.5 in the fleet. She is ready to take you and your family sailing in complete style. Comes with mainsail, jib, 2 spinnakers and a heavy duty trailer with four brand new tires. \$10,000. Bill (510) 521-8075 or capt207@aol.com.

1986 HANS CHRISTIAN 33 CUTTER. Original owner, good to excellent condition, new bottom 10/07, 80-gal fuel, 90-gal water, Kenyon tapered spars, Navtec backstay adjuster, all rigging and winches oversized, Sea Tiger windlass, 1 Bruce and 1 CQR with 75' chain/rode. Seaward stove/oven/heater LPG, Cool Mate refrigerator, microwave, Yanmar 3QM30 freshwater cooling, Icom IC-725 SSB, weather fax, Icom IC-M55 VHF, Autohelm 7000, Raytheon R20 radar, Raynav-570 Loran, Si-Tex A310 satellite navigator, Harken Mk III jib furling, new Sutter sails 2003, 3/4-oz. reacher drifter, 1/2-oz. spinnaker with 4" pole and rigging, 130 genoa, 75-amp alternator, True Charge battery charger, 2 battery banks, Sony stereo/CD player, 2-man raft, more. \$100,000. Located Lake Tahoe, CA. (775) 287-9360 (days) or (775) 852-0321 (eves) or kathi.kunze@gmail.com.

TARTAN 10 SAILBOAT. Brand new bottom job. 3 jibs, all Mylar sails, spinnaker. Rebuilt Farryman diesel, excellent condition. \$15,000/obo. Call (415) 453-0610 or email: jeff@mintowilkie.com.



DOWNEAST 32 CUTTER, 1979. Good condition. 24-hp Universal diesel, furling jib, bimini, davits, radar, refrigeration, autopilot, solar. New running and standing rigging, hardshell dinghy, older Achilles inflatable, 3-hp Evinrude. Lying LaPaz. \$31,000. (949) 500-0652 or dgroverman@aol.com.

WESTSAIL 32, 1977. Well equipped and maintained. Excellent condition. Outfitted for cruising. 28-hp Volvo 2003. Dual Racors. Stove and oven. Refrigeration. Documented. Tools and many extras. Located San Rafael. \$48,500. Call (415) 729-6127.

COLUMBIA 34 Mk II, 1972. Well equipped with hot/cold pressure water, Force 10 stove, new interior cushions, very liveable. Less than 100 hours on new Yanmar 3YM30. \$24,900. (510) 521-1062 or (510) 316-0594 or b.bostrom@yahoo.com.

CLASSIC WILLIAM GARDEN KETCH. Relocation forces sale. Perkins 4108, new diesel tank. Hauled out last October. New sails, main and mizzen custom made from North sail. 8-ft beam, 8-ft keel. Cedar on oak, built in Oregon in 1970, have plans. This 35-ft ketch is easy to sail. \$7,500. Call Opal (415) 717-8243.

WESTSAIL 32 HULL, DECK, all lead ballast, rudder and steel cradle. Custom LaFiel mast and boom, custom stainless steel bowsprit and boomkin, ABI portlights, two shipmate stoves (one for parts). NIB Aries windvane to fit the boomkin and NIC Sabb model G 10-hp variable-pitch prop diesel and misc. parts. \$22,000. Call (831) 239-2914.

OFFSHORE ONE DESIGN 34, 1980. Doug Peterson design, Jeremy Rodgers construction. Excellent condition. Carefully maintained and improved with many recent upgrades. Exceptional value at \$39,000. Call (415) 388-2582 or (415) 552-0860 for more info. Photos and details at: <<http://yacht.milagro.googlepages.com/home>>



RAFKI 35, 1979. Full keel bluewater sloop, cruise ready. Full electronics, TV, watermaker, new sails and rigging, Yanmar, wind generator, solar, full cover. We moved back east. You will not be disappointed. \$49,000. (802) 552-4549 or mark@rosanne.info.

MARINER 32 KETCH, 1979. Unicorn. Bay sailing, liveaboard, or cruising. LOA 32-ft (9.8m). Beam 10-ft (3m). Draft: max 4-ft (1.2m). 42-gal fuel (132.5 ltr). 35-gal water (132.5 ltr). Full keel, fiberglass hull, aft cockpit. Anchor windlass, Harken roller furling Mk III. All sails in good condition, new sails and hatch covers. 3 Barlow #20 winches, rack and pinion steering, wheel and emergency tiller. Signet knotmeter and depthsounder, compass, new VHF. Alcohol 2-burner stove, ice box, pressure hot/cold water. Perkins 4-108 37-hp diesel. \$25,500/obo. Can be seen on Dock 5, Brisbane Marina. Bob (650) 355-5166 or (650) 996-4631 (cell).

J/105, 2002, SAIL #497. Stars & Stripes Blue hull, B&G instruments, 20/20s, autopilot, Furuno GPS, GoriProp, Standard VHF with ram at helm, Sony stereo. Shorthanded set-up. Antal cars on trac with lazyjacks. All can be removed for one-design racing. Good sail inventory. Very light use. \$124,000/obo. John (415) 332-6395.

ARIES 32 ROUGHWATER. Mexico vet, cutter rigged. Great bluewater pocket cruiser. Windlass, spare sails, 4-cylinder diesel, Ham radio, 12v refrigeration, large battery bank, propane heater, new standing rigging, roller furling. \$16,500. (707) 462-4142.

ERICSON 32, 1969. Make cash offer For liveaboard: microwave, stove and BBQ on propane system, holding tank, stereo sound system. For cruiser: autopilot, 3 sails, VHF radio, rebuilt Atomic 4 with 800 hours. At Owl Harbor, Slip D-5. (209) 572-2934 or phillipsfred@sbcglobal.net.



HUNTER 33, 2004. Excellent condition. Glen Henderson design. Absolutely the most custom, cruise-ready 33 on the planet. All top-quality hardware and installation. Too many options, custom products and systems to list. Handles easily and is very spacious and comfortable. Located in Puerto Escondido, Baja, Mexico (no tax delivery). On private anchor system in harbor at \$30/month rent. Will deliver to US location. Divorce forces sale. \$112,500. (415) 992-8057 or <www.myspace.com/carlosmango>

NOR'WEST 33. Classic bluewater racer/cruiser featured in November, 2006 *Cruising World Classic Plastics*. 1978, hull #6. Cruising ready. Full complement of sails, wind generator, solar panel, new bimini and interior upholstery, radar, GPS, Monitor self-steering vane, autopilot, new standing rigging and Harken Mk IV roller furler at headsail. LectroSan waste treatment system, all new head plumbing, bottom paint, new multi-stage battery charger. Most systems replaced in past 10 years. 2006 survey available. Currently berthed in San Diego. Asking \$55,000. Call (510) 301-3431 or email: sailskye@pocketmail.com

COLUMBIA 34, 1973. Roomiest of them all. 7' plus headroom with nice woodwork below. New barrier coat, bottom paint and survey. \$12,500. 12' Yukon dinghy also in great condition, \$800. Like-new trailer available. 5/16" chain x 250 ft, \$200. (916) 777-5510.

ERICSON 35 Mk II. Unbelievable deal. Equipped for cruising, sailed to Mexico and back, now must sell. Strongly built, comfortable boat. Yanmar 3GM30F, Ballenler spar, windgen, wheel/tiller steering. Equipped to live aboard. Too much to list. \$28,000/obo. (415) 992-5365 or email: mr_determined@hotmail.com.

NOR'WEST 33, 1979. Well-maintained, modified full-keel bluewater sailboat. Roller furling jib with 110% and 80% sails, Yanmar 20-hp diesel, tiller with autopilot, quality teak interior. \$29,500. Call Kris (415) 378-3342.

33-FT PEARSON 10M, 1976. Very good condition. Family loss forces sale. Easy to see in San Rafael. Asking \$17,500/obo. Jack (415) 225-4982.

WESTERLY 32 SLOOP, 1974. British-built fiberglass offshore cruiser, well equipped, singlehanded to Hawaii. Volvo diesel with low hours, self-steering, very comfortable interior, lots of storage aboard. Dry-docked 6/08. Must see to appreciate. \$22,000. (805) 239-7716.

CORONADO 32 AFT-COCKPIT, 1973. Skeg, deep keel, tall rig, steady, fast. New interior cushions, CNG heater, stove, custom table. Palmer 60 gas, new ss tanks, roller jib, wheel, cockpit table, CD, VHF, dodger. \$12,000. In Alameda. (510) 467-8372.

ROUGHWATER 33. Traditional double-ender. Fiberglass hull with full keel. Strong bluewater cruiser. Completed two-year solo circumnavigation. Furl-Ex roller furling on headstay. Fleming windvane. Electronic tiller/pilot by Sim-Rad. Simpson-Lawrence windlass. Solar panel. water-maker. Furuno GPS. Epoxy barrier coat on hull. Reliable 20-hp Yanmar diesel. \$32,000. (650) 851-7795.

PEARSON 32 RACER/CRUISER, 1979. Fast cruising boat, easily singlehanded. Recommendation: See August 2007 *Practical Sailor*. Original M-15 Universal diesel, 1,250 hours. Gear, about 1995: autopilot, digital depthfinder and gauge, genmaker, Harken furler, Navtec backstay adjuster, Quik Vang, radar, WM Loran-C, 25-watt marine radio. New: electric fuel pump, 10-gal. aluminum fuel tank 2002, batteries 2006. Documentation: all original manuals, surveys, maintenance, diving, haul records since my 1995 purchase. Location: Alameda. \$23,500 or good offer above BUC 'fair'. (510) 525-2754.

36 TO 39 FEET



39-FT X-119. Excellent condition. New sails 2007. New running rigging 2008. Too much to mention. For more info email: steenmoller@sbcglobal.net.



MARINE SURVEYS by Captain Alan Hugenot
Naval Architect • Yacht Delivery Skipper
Accredited Marine Surveyor (SAMS)
••• Bay or Delta • No Travel Charges •••
All major credit cards accepted • (415) 531-6172

CALIFORNIA CS MARINE

Boat work done in your slip • 21 years experience • Competetive rates
General maintenance • Custom topside paint and varnish
Bonded • Insured • License #750805
(650) 341-0622

MARINE ENGINE CO.

Complete Engine Services • Gas & Diesel
30 Years Experience • Reasonable Rates
Tune-Ups • Oil Changes • Engine Rebuilding, etc.
(415) 332-0455

N.E. MARINE TITLE

Coast Guard documentation • Title/lien searches • Transfers • Mortgage filing • Escrow services
Local closing facility for brokers or private transactions
30 years experience of doing it right the first time
1150 Ballena Blvd, Alameda, CA • (510) 521-4925

SAUSALITO

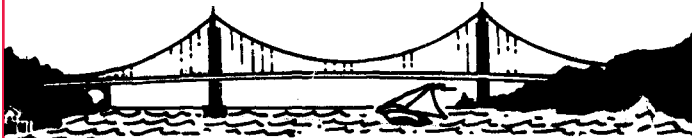

LIST MARINE INC.

- Full service engine shop
- We service all makes
- Dockside facilities
- Mobile service trucks



YANMAR
marine

P.O. BOX 2008 / 69 LIBERTY SHIP WAY • SAUSALITO, CA 94966
Adjacent to Schoonmaker Pt. Marina

415•332•5478
www.listmarine.com

Custom Canvas & Interiors



The Gianola Family has been designing and fabricating custom canvas and interiors since 1969. Gianola & Sons offers you the best in quality, more choices, and personal service.



360 Gate 5 Road
Sausalito, CA 94965
(415) 332-3339
www.gianolacanvas.com

CAL 39, Mk III, 1982. Excellent ocean-sailing vessel with three-cabin design, includes many extras including new roller furling, new bimini, and new fuel tank. Rebuilt diesel with 90 hours. \$69,500. (408) 202-1151 or Doug.swanson@earthlink.net.



ISLAND PACKET 380, 2003. 39'7" full keel, fiberglass, well-maintained blue-water cruiser. Spacious master and guest cabins. Large head with full shower. Propane stove. Dodger/bimini. Full electronics. Autopilot, radar, GPS, VHF. Cruising package. Cutter rig, inmast furling, Harken furling staysail and jib, asymmetrical spinnaker, storm trysail, jib pole, multiple Lewmar winches. Boom brake. 9' inflatable, 6-hp Nissan, EPIRB, Yanmar 56 hp with 386 hours, bow thruster, fridge/freezer, windlass, many extras. \$249,000. Lying Richmond, CA. Call Bernard Lemke (707) 621-2626 or bernardlemke@gmail.com.



HUNTER 36, 2007. Delivered 08/07. Can't make the payments. All 36 features, many extras: Electric windlass, second anchor, dodger, hardware for cruising spinnaker, inverter, quiet-flush head, Raymarine C80 GPS and radar, complete galley, AM/FM/CD with cockpit speakers, fitted cushions, 50-hour dealer service on 29-hp Yanmar diesel. Original price \$217,000. Will sell her for \$175,000. (650) 493-5059 or raneyt@pacbell.net.

ISLANDER 36, 1977. Perkins 4-108, new rigging 2002, 2 self-tailing Harken 44s, 2 self-tailing Barlow 25s. Dodger, covers, holding tank, macerator, propane stove/oven, radar, chartplotter, VHF, bowroller, 2 anchors/chain and rode, carpets/curtains, Avon/ob. Alameda Marina #204. \$55,000/obo. Arnie (415) 999-6751 (cell) or (415) 383-9180 (hm) or email: arnoldgallegos@comcast.net.



HANS CHRISTIAN 38T CUTTER. 60-hp Yanmar diesel, 300 hours. Radar, chart-GPS, windlass, bow thruster, VHS, 18-gph watermaker with 200-amp genset. Cold-plate fridge, windvane, Ham with email. 2 mains, 2 jibs, 1 spinnaker, 1 staysail. Asking \$119,000. Call Mike (916) 256-8078.

ISLANDER 36, 1977. Major recent refit including teak and holly sole, headliner, cushions, Profurl jib. Sound system, dodger, covers, boot, fathometer and speedo, new ports, 3-cylinder Yanmar diesel. New FW heater and pump. Great boat, excellent condition. \$54,000. Sail away. (707) 542-1906.

CATALINA 380, 2000. Full electronics, Leisure Furl boom, Vectran mainsail, electric winch and windlass, inverter/charter, ultra-leather interior, flat-screen TV, Glassmat batteries, full cockpit enclosure, electric head, Yanmar engine, 220 hours. Alameda. Asking \$135,000. (916) 632-9317.



FAST PASSAGE 39. Legendary cruising yacht. Two-time Hawaii, three-time Mexico vet. New engine, prop, dinghy, dodger, gennaker. Much much more. \$140,000. For details, email: DRJY2K@aol.com.

CATALINA 36 Mk II, 1996. Universal diesel, 600 hours. New bottom Dec. 2007. New dodger and bimini, roller furling, three headsails. Garmin chartplotter, autopilot, wind direction/speed, depth. Meticulously maintained, beautiful interior, like new, must see. No disappointments. \$105,000/obo. (925) 228-2852.

FREYA 39 HALVORSEN steel sloop. Insulated, new rebuilt 85 hp Ford diesel. Autopilot, radar, GPS, fridge, shower, hot water. Hood rollerfurl, hydraulic windlass, sounder, dodger, refurbished aluminum mast/boom. Recent haulout, sandblast, paint 8 coats. \$48,000/obo. Pics: traime69@hotmail.com or (805) 200-6089.



CAL 39, 1978. SAME OWNER for 16 years. Many upgrades, including rebuilt Perkins 4-108 engine and transmission. New tapered double-spreader mast, aluminum toe rails, radar, electric windlass, below-deck autopilot, headliner, port lights and watermaker. Hard dodger and bimini with new canvas, cockpit screens, and solar panels. Updated galley with new deep double stainless steel sink, refrigeration, stove/oven and microwave. Much more. Price reduced by \$6k to \$69,000. (209) 327-0274.

CAPE DORY 36 CUTTER, 1980. Active cruiser now in Mexico. WH autopilot, Monitor windvane, VHF and Ham/SSB radios, SCS Pactor, sun panels, radar, watermaker, Adler Barbour fridge, spinnaker, Aquapro dinghy, 15 hp, much more. Survey 2006 available. See: < www.seaternsurvey.blogspot.com > \$79,500. svseatern@aol.com.

SABRE 362, 1998. Well maintained. New mainsail and spinnaker. Recent bottom and topsides paint and rigging. Wing keel with 4'6" draft. Autohelm, dodger, furling jib. Beautiful boat in Berkeley. \$175,000. Call (925) 766-2205 or email: dan@deltaexcavating.net.



38-FT SLOOP, 1970. Canadian-built Hughes. Sails well, has new diesel inboard engine. Located in Monterey, CA. (831) 915-4984.

ISLANDER 36, 1978, CYGNET. Hull #495. Original owner. Never raced. Always meticulously maintained. Navy blue hull, white topsides and rig. Beautiful appearance, turnkey conditions. Perhaps the prettiest I36 on the Bay. Located SF marina. \$55,000. Call (415) 596-7271 for details and to inspect.



2003 FARR 36 ONE DESIGN. Hull #2 with Triad trailer. Large sail inventory both North and Quantum, very nice instrument package, Furuno GPS plotter. Boat new to West Coast via Annapolis and Key West. Very fast and fun. Asking \$139,000. (530) 583-5150 or johncorda@hotmail.com.

38-FT SAILBOAT. MORGAN 382, 1980. Cruise equipped. Below-decks Autohelm, radar, 50-hp Perkins 4-108, A/B fridge, propane stove/oven, windlass, full dodger and bimini. Too much to list. \$63,900. Email: sv_indigo@yahoo.com.



GULFSTAR 37, 1977. Aft cockpit. Recently rebuilt Perkins 4-108. Radar, GPS, VHF, Autohelm, electric windlass, Harken roller furling, speed/depth, dodger/bimini, dinghy and motor. Lots more. Good condition. Great island boat. \$51,500. Call Don in Ventura. (805) 672-0007.



ISLANDER 36, 1977. All original docs and manuals, Perkins 4-108 pulled 2004, never raced. PUR watermaker, pressure hot/cold water, inverter, auto charger, radar, Raymarine wind, GPS, chartplotter, Autohelm, diesel heater, new Force 10 oven/stove, BBQ, 5-year rigging, 35# CQR, 150-ft 3/8" chain. Horizontal windlass in anchor locker, lightly used full-batten main, Harken Mk III furler, cruising spinnaker, Barlow st winches, new main windows, new electric panels, davits, full covers, extras. \$44,000. Call John (510) 326-9829 or jtsut@aol.com.



RAFIKI 37. Good condition. Cutter rig, new electrical and running rigging, fuel tanks, new LPU and brightwork. Sound boat. Needs new cushions. \$59,000. Tom (510) 672-1646 or (510) 799-1712.

FREYA 39. Well-known Australian offshore design. Originally cutter, easy to change back. One owner, hull #4, 1977. Mast repaired after damage in Chile, fully tested, with new chainplates and rigging. Yanmar 3-cyl, 2,170 hours. A great passage-maker. \$49,500. (925) 522-1353.

ERICSON 38, 1981. Universal 3542 diesel, dodger, roller furling 90% and 150% headsails, 2 mains, Navtec backstay, rigid vang, newer cabin cushions, new head and hoses, new batteries, teak interior with teak and holly sole. Located Benicia. \$45,000. (530) 902-3503.

40 TO 50 FEET

MASON 44 CUTTER. Commissioned 1990. *Juliet* is possibly the finest Mason on the West Coast. She has a Yanmar 55 hp, 1,132 hours. 5-kw generator, 341 hours. New in 2000: in-mast main furler, Harken headsail furler, Furuno radar, ICOM SSB and VHF, GPS, autopilot, 2-kw inverter, B&G gauges. The teak joinery, Lewmar hatches and ss ports are like new. No teak decks, dry. Inflatable with outboard and a liferaft. \$260,000. Call (206) 780-8984 or jam.mac@earthlink.net.

HARDIN 44. CLASSIC BILL HARDIN ocean cruiser back from cruise to Panama, Caribbean and east coast. Waiting for her next adventure. All sails roller furling. Fiberglass, Isuzu C240, 200 gals fuel/water. Long Beach. \$75,000. (480) 215-8224 or pilot435@hotmail.com.



WAUQUIEZ CENTURION 45. High quality, very safe performance cruising yacht by Wauquiez, designed by Dubois with stellar record for fast, comfortable offshore passages. Solid FRP hull, masthead sloop, removable cutter stay and stays'l, dyform rigging, owner's layout, fine European joinery. Icom SSB and VHF, Furuno radar, Garmin GPS, Raymarine ST 7000 autopilot, Harken furling, full-batten main, Windpilot servo-vane, swimstep transom, Lofrans electric windlass, dual refrigeration, new Balmal alternator/smart charger, 1000w inverter, AGM batteries 2006. Too much to list. Priced to move at \$185,000. 04/07 drydock survey available. Caribbean, South Pacific, Hawaii passages with up to 200 mpd made good. This boat can go anywhere you want. Photo catalog and inventory available. For more info contact: tunes@aloha.net or call (808) 826-6050.



BALTIC 43, 1987. A truly beautiful and well-cared-for vessel, one of only 47 in the world. Fast, responsive, fun to sail and is well suited for daysailing or extended ocean passage. Berthed in Sausalito. \$210,000. <www.sfdolphindance.com> (831) 684-2457.



BILL TRIPP COLUMBIA 43. Achilles inflatable with 9.9 Evinrude. 2 Garmin plotters, 2 sounders, refrigeration, Ray autopilot. Good condition in northeastern Panamanian Islands. \$45,000/obo. (928) 910-2288 or rockndammer@yahoo.com.



FORMOSA 41 KETCH, 1978. Beautiful sailboat, excellent condition, bluewater veteran ready for more. Many upgrades. USGS documented. Located on Rio Dulce, Guatemala. \$59,500. See specs, photos at: <www.tombuttsmontana.com/dragonlady.html> (406) 431-9582 or tombutts10@hotmail.com.



47-FT CUSTOM FIBERGLASS CUTTER, 2004. Bluewater high-latitude cruising sailboat. Two helms, one enclosed. Sleeps six, premium equipment, electronics, 85-hp diesel, 4.2kw generator, workshop, 200+ fuel and water, refrigeration, washing machine, insulated. \$575,000. Pictures: <www.hyssop.com/boat/> Coos Bay, OR. (541) 888-5688.

2003 BENETEAU 423, HULL #1. French built. All factory options. Also Spectra watermaker, liferaft, AB dinghy 18-hp Tohatsu, a/c, heat, three 120w solar panels, 750 amp/hr AGM. Full batten main. \$185,000. No brokers. svpaxil@gmail.com.



47-FT OLYMPIC OFFSHORE cruising ketch. Ted Brewer design, hand-laid fiberglass to Lloyd's specs, 3 staterooms, spacious accommodations, 75-hp diesel, LPG oven/stove, refrigerator/freezer, hot water, radar, VHF, GPS/chartplotter. See more at: <www.rebeccasailboat.com> \$147,500. (360) 452-5050 or (360) 928-3058.

DIVORCE FORCES SALE. 42-ft aluminum-hulled cutter-rigged Selestra 1983. Fin keel with skeg-hung rudder. Soft chine. Perkins engine. New Raymarine GPS, chartplotter and radar. New headliner. Berthed in Emeryville. All the standard equipment. \$109,000/obo. Bob (928) 699-0461.



YACHT DELIVERIES

Royal Yachting Association & USCG-Licensed Captain available to deliver your yacht in a safe & professional manner

Andy Signal (408) 858-2639 • www.andysignolyachting.com

August Enterprises

Marine Surveying and Consulting

Serving the Bay Area since 1995

510-889-8850

Online and home study courses in all areas of marine navigation and weather

★ ★ ★
STARPATH®
School of Navigation

(800) 955-8328 • www.starpath.com

More than 25,000 students since 1977



ISLAND PLANET SAILS

Low internet pricing • Exceptional service • Attention to detail
Quality materials from Bainbridge and Dimension Polyant
World class design team with America's Cup experience
www.IslandPlanetSails.com • (510) 931-6499

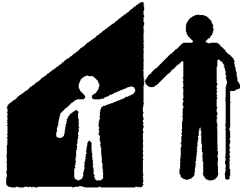

AGAPE VILLAGES

FOSTER CHILDREN NEED YOUR HELP!



Donate your boat to support

AGAPE VILLAGES

Tax Deductible

1-800-513-6560

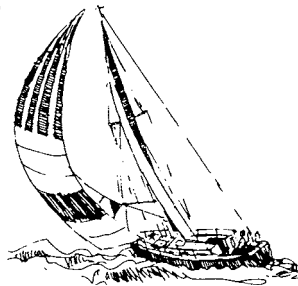

DF DIESEL FUEL FILTERING



Purify Diesel Fuel & Clean Tanks

Process scrubs, polishes, removes algae, dirt, sludge, rust, water, and foreign particles from diesel fuel.

Includes internal tank washdown. Save your injectors, costly engine repair and down time.

Since 1989. Fully insured. Your berth or boat yard.

(510) 521-6797 Fax: (510) 521-3309

QUALITY SAILS FOR LESS!



**MAINSAILS
MIZZENS
STAYSAILS
HEADSAILS
CRUISING SPINNAKERS
MAINSAIL COVERS
ALL CUSTOM FIT**

(510) 769-4858 • leesailsnc@yahoo.com

2021 Alaska Packer Pl. • Grand Marina • Alameda, CA 94501

SAILMAKERS TO THE WORLD!

KELLY PETERSON 44, 1979. Fully equipped for cruising. Self-contained, go anywhere boat. \$125,000. Location: Mazatlan, Mexico. More info/photos: (818) 364-1920 or ellenbgannon@yahoo.com.



MASON 44 CUTTER, 1993. Ready to cruise anywhere in class, comfort, safety. Difficult to find a better bluewater cruiser at any price. \$265,000. Details/photos: <www.WizardMason44.blogspot.com> Call (760) 610-2198 or (626) 695-5560 or email: fmelone@dc.rr.com.



ANACAPA CHALLENGER 42. Center cockpit. Heavy-built full-keel cruiser. Real queen-sized mattress in master cabin. Sleeps 6, fully enclosed cockpit, 12' dinghy with 6-hp ob. Large gourmet galley, Isotemp refrigerator/freezer, Iso-therm water heater, Princess oven/stove, all new. Quantum jib, main, spinnaker. Redundant electronics: 3 VHF's, ICOM SSB with Pactor III email, upgraded. New Furuno DGPS antenna. New Nobeltec WAAS antenna. 235 gals fuel. Primary fuel tank completely cleaned, resealed from inside. New FilterBoss dual fuel filter and polishing system. Hydraulic windlass, new chain, 3 anchors. 5 new Lewmar hatches, new Bomar portlights throughout. No leaks. Solar, wind, lifeboat, kayak, plus spares. 100-hp SD33 engine. New cylinder head and ss muffler. New Nobeltec AIS system. \$85,000. Call (916) 880-8896, jhardi95616@gmail.com.



HYLAS 42, 1987. German Frers designed. Fast, comfortable. Continuously upgraded, outstanding condition. Refitted/outfitted by professional shipwrights and/or boatyards in 2005/2006 for long-distance cruising. Extensive equipment list includes watermaker, solar panels, ShadeTree, refrigerator/freezer, Monitor windvane, autopilot, EPIRB, asymmetrical spinnaker with pole, 3 GPS's, SSB/Ham with Pactor modem, radar, electric windlass, 125-amp alternator, liferaft, dinghy, 9.9 outboard, LED tri-color/strobe/anchor light, shade panels for cruising bimini, custom mattresses, great galley, and more. Located San Carlos, Mexico, ready to go. \$145,900. (206) 604-2650 or svangelfish@yahoo.com.



NAUTOR'S SWAN 43 CRUISING center cockpit, 1977. First time on the market since new. All manuals and literature available. Newly refurbished teak decks, Perkins 4-236 85-hp diesel, ss fuel tanks (2) 299 gal. SS water tank (3) 285 gal. B&G instruments, Northstar GPS, 24 radar, ICOM Ham and SSB. Harken furling, autopilot, 3-Blade MaxProp, Espar diesel heater, Keefe windlass, 4-kw generator, custom ss davit with Achilles dinghy and 15-hp ob. Too much to list in this ad. New dodger and bottom paint 5/08. No brokers. Asking \$195,000. For info call Mike (949) 374-4184 or nautorswan43@msn.com.

MAPLE LEAF 48. Just completing a major refit of all cosmetics and systems. Way too much to list here. For pictures and details, visit website: <www.captfht2.com> (720) 221-8295 or email: captfht2@captfht2.com.



HERRESHOFF CARIBBEAN 50. 14.5' beam, 6' draft. Perkins 6-354. Radar/AP/SSB-HAM, VHF, Probe, liferaft, spares and tools. Fresh interior refinish. Photos and info on <www.sailboatlistings.com> Located Eureka, CA. \$199,500. (707) 834-4798.

SAMSON 40 CUTTER. Just back from Mexico cruise. 600 hours since rebuild on Volvo diesel. Dutchman flaking on main. Sails and rigging recently replaced. See: <www.svpatriarch.com> \$44,000. Call (707) 961-2080 or email: rbrandes@aplusevents.com.



HUNTER 430, FAST AND VERY comfortable, *Espiritu* is completely updated and ready for trouble-free enjoyment, at the dock, on The Bay, or down the coast to Mexico. We're just back after a two-year shakedown cruise in Mexico. Now it's your turn to enjoy this two bedroom, two-bath super-clean vacation home. Complete with radar and electronics, huge freezer, central heat and air conditioning, microwave, generator, liferaft, dinghy, new AGM batteries, on and on. \$145,000. Part trade OK for trailerable or transportable boat. For complete information call Pat (916) 281-5238 or espritu430@yahoo.com or go to: <http://patsysweb.com/HUNTER_430_LEGEND_for_sale.html>

PETERSON 44 CENTER COCKPIT cutter, 1977. Two staterooms, two heads. New Yanmar, LP, fuel tanks. Robertson autopilot, radar, dinghy, outboard. \$109,000. San Carlos, Mexico. Call or email for complete list and photos. (520) 742-2727 or (520) 235-6695 or svubetcha@aol.com.



GREAT LIVEABOARD, \$169,500. 1979 Hudson Force 50 offshore cruising ketch. 5 staterooms, 2 heads, 80-hp diesel, 220-gal fuel, 260-gal water, watermaker, autopilot, SSB/Ham, liferaft. Specs, photos available. Blaine, WA. (360) 371-0904.



BENETEAU 423, 2003. Excellent condition, like new, deep keel, 2br/2ba, color GPS, Raymarine instruments, LINK 1000 inverter, folding MaxProp, engine under 200 hours, 2nd anchor, EPIRB, dodger, full Delta boatcover, extras. Haulout March 2007. \$199,500/obo Email: hcben88@gmail.com.



CELESTIAL 48, 1986. REBA. Spacious, well-built center cockpit ketch. Fantastic boat. Excellent condition. Many special features. Fully cruise ready. Great value. See overview and details at: www.celestial48.com.

FD-12, 50-FT FIBERGLASS pilothouse cutter, unsinkable thanks to added foam flotation, easily handled by 2. Dedicated berths for 5-6 in 2 staterooms forward and 1 stateroom aft, good privacy for parents with children or 2 couples. Superb galley in pilothouse, view, daylight, and counter space. SoPac and Mexico vet, fully equipped with tools and spares, ready to go cruising. Make a deal by October or she's going cruising in Mexico for the winter. See www.svdreamer.com



VAGABOND 47, 1982. Full keel, 5.6' draft, 13.6' beam. Fiberglass. Many custom features and upgrades highlight this cruise-ready, center cockpit, cutter-rigged ketch. They include: Aluminum pilothouse, 1-1/2" stainless tubing handrails and bow pulpit, aluminum dinghy landing platform/ladder, electric windlass, 88-lb Delta with chain and rode, 85-hp John Deere, 4.2kw Entec genset, Webasto diesel heating system. Watermaker, Splendide washer/dryer, large aft cabin, 2 heads/shower, fridge and freezer, liferaft, electronics, stainless water tanks 350, aluminum fuel tanks 210. Sails are all roller furling, aluminum masts and much more. Located at City Docks along Hwy 1 northbound, Coos Bay, OR. \$229,000. Email: skboehm.1@juno.com for more information and photos. Call Tim (928) 920-1767.



CALIBER 40, 1993. Beautiful, bluewater cruiser. Sailed from Seattle to Sea of Cortez in 2002 (Ha-Ha IX). Loaded with cruising equipment. Located in San Carlos, Sonora, Mexico. Asking \$167,000. For complete specs and photos contact: (206) 799-5222 or svkokomo@hotmail.com.



HANS CHRISTIAN 48 CUTTER, commissioned 1990. One of only two aft-cockpit 48s ever built. Dependable Lugger diesel, 8kw Panda, new electronics, radar and autopilot. Huge fuel and water capacity. Spectacular teak joinery. This boat was built for one of the owners of Hans Christian as a showboat for the company and is arguably the finest boat built by that respected firm. A floating palace and a powerful sailer. \$289,000. Tom (510) 525-6168.

ROBERTS 43 FIBERGLASS center cockpit ketch. In-mast furling, radar, electric windlass, 10-kw diesel generator, air conditioning, refrigeration, watermaker, washer/dryer and cockpit enclosure. Needs cushions, new sails and general refurbishing. Located Morro Bay. \$65,000. Call (805) 674-0678 or captij@charter.net.



HUNTER PASSAGE 42, 1996. \$165,000. Ready to cruise with autopilot, SSB, radar, 2 chartplotters, dinghy with outboard, etc. See full details, photos, etc at: www.svdakota.com Richmond, CA. Call (925) 200-9659 or email: ed@svdakota.com.



CAL 2-46 KETCH, 1974. Liveaboard, 2 staterooms, 2 heads, engine room/workshop, heavy stainless dodger. Upgrades: shaft, propeller, Raymarine E120 radar, VHF, Schaefer furler, dual Racor filters, upholstery, Force 10 3-burner stove, dinghy, 9.9 Merc and more. \$110,000. Info/pictures: www.StillCrazySailing.com (831) 708-2144.



MAPLELEAF 48. 4-cabin large-volume sloop built in British Columbia 1974. Excellent liveaboard/cruiser. Comfortable all-weather pilothouse. Teak interior. Spacious, bright salon, table seats 6+, wood fireplace, nav station. Large galley with 2-seat nook. 2 double berths, 2 single berths. New head with shower. Beam: 14'8", draft 6'6", 19 tons. Isuzu DA120-hp engine, 800 hours, good condition. Recent rigging. Sails, hull OK. Solar, Furuno, Raymarine instruments. Water/fuel 300 gals. Needs work. Available Monterey. Email for photos, 2007 survey, description: bobbi_long@csu.edu or call (831) 224-3326.



INFRARED, LAURIE DAVIDSON 45. IOR and PHRF winner of both North Long Beach Race Week and St. Francis Big Boat Series. IMS-Americap II and IRC certificates available. 20 or so sails, recent carbon Technora main, 1,2,3 jibs. Both 7/8 and masthead kites roller furler and self-tacker. Recent Volvo upgrade 42-hp diesel, also Zantex inverter/charger plus 4 new no-maintenance gel batteries. New Adler-Barbour icemaker, CNG 3-burner stove/big oven. Also inverter-driven microwave oven. All Sailtec hydraulics systems recently rebuilt. Bottom is vivid white. Full bottom peel and redo 2007. Flex-O-Fold 3-blade full-folding prop. Asking \$98,500. Call Ray Lopez, PO Box 16, Burson, CA. 95225. (209) 772-9695.



50-FT DEL REY IN PANAMA. Cruiser/liveaboard, complete refit 2002. USCG documented. All fiberglass, center cockpit, full keel, roller furling, teak interior, large aft cabin, fully equipped, good condition, dry. New Cummins 135-hp engine and bottom job. Photos: www.usedboats.com \$85,000. Email: emerada4sale@hotmail.com.

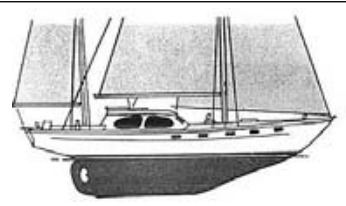

COUNTESS 44 KETCH, 1965. Alden designed, Pearson built. Full keel, beautiful sheer, flush foredeck, meticulously maintained and upgraded with extensive electronics, 120-hp auxiliary, 7.5kw generator and cruising gear. Outstanding liveaboard ready to cruise. \$120,000. Visit www.geocities.com/kochab1965 or (415) 720-5477.

'Electronic Latitude

Sailing News Every Mon-Wed-Fri

www.latitude38.com

Yacht Repair
Design / Consulting

Custom Interiors
Exterior Joinery



**STEVE'S MARINE
WOODWORK**

60 C Libertyship Way, Sausalito
jonessail@aol.com • (415) 332-2500

SMALL AD, SMALL PRICES • RIGGING ONLY

Standing and running rigging, life lines, furling gear, winches, line, windlasses, travelers, wire and terminals, blocks, vangs, and much more.

~ ~ ~ Problem solving and discount mail order are our specialties ~ ~ ~

www.riggingonly.com • (508) 992-0434 • email: sail@riggingonly.com



MARINE SURVEYS • Jan Van Sickle

Member: SAMS – AMS, ABYC & IAMI

Ultrasound Thickness Testing of Steel & Aluminum

jtvs@post.harvard.edu • www.vintageyachts.org

(707) 939-9131 • No travel charge within Bay Area

VOLVO PENTA

Specialist Dealer Since 1980

ESKELUND MARINE • (510) 523-7670

1913 Clement Ave • Alameda Marina • Bldg 13 at Pier 2



Easom Racing and Rigging

1150 Brickyard Cove Rd., Suite B1
Point Richmond, CA 94801

(510) 232-SAIL (7245)

www.easomrigging.com

DONATE BUY SELL CLEAN



- Donate your boat for a tax deduction
- Learn about our For Sale by Owner program plus tax deduction
- Quality used boats for sale
- Topside cleaning service, every first Saturday of the month, \$2.00/foot

*Fundraiser for Ship 65 Sea Scouts
and Historic Boat Restorations*

650-380-5535

GOLDEN STATE DIESEL MARINE

PARTS

YANMAR • UNIVERSAL • WESTERBEKE
PERKINS • ISUZU • PATHFINDER • ATOMIC 4

SERVICE DIESEL ENGINES

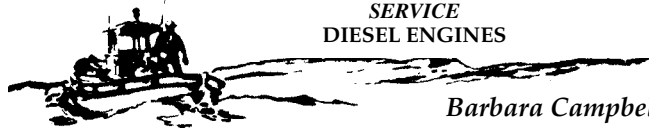

Barbara Campbell

351 EMBARCADERO
OAKLAND, CA 94606

(510) 465-1093

Vessel Electric

*Marine navigation installations and expansions
of existing systems*

- Electrical installs and trouble shooting D/C and A/C systems
- Raymarine® warranty dealer and certified installer
- NMEA-certified Marine Electronics Installer • Insured

Brian Theobald • (415) 424-2204
vesselelectric@yahoo.com



CT 41 KETCH. Bill Garden design, 1973. Roomy teak saloon and comfortable captain's berth. New chain plates, rebuilt Volvo-Penta diesel, new fuel tanks, full cover, well maintained. Docked Berkeley. \$65,000. Neil 415-407-6403 or email: silvernrc@earthlink.net.

DOWNEASTER 45 KETCH, 1977. Center cockpit. New: 4-236 Perkins, transmission, starter, alternator, 5-kw Northern Lights, 12vdc and 120vac Ancor wiring, and running rigging. Three cabins/two heads, lots of storage, many custom touches when built, great liveboard. Two CQRs, chain forward, two Danforths, 17 winches, two whisker poles. Needs: standing rigging, electronics, teak needs TLC, refrigeration, interior detail. Liveboard slip possible in Alameda. One-half market price \$89,000. Email: svliberty2@gmail.com or call (541) 654-1576.

51 FEET & OVER



FORMOSA 51 KETCH, 1981. Just hauled. Loving care by second owner for 23 years. Sitka spruce spars, stainless steel crow's nest. Roller furling boomless main, staysail. Maroon covers. Teak interior, varnished throughout. Benmar autopilot, radar, VHF, 80-hp Ford Lehman diesel, diesel heater, propane stove with oven, propane water heater, cold-plate freezer/fridge. 220-gal fuel, 220-gal water. 3 staterooms, 2 heads. Set up to single-hand. Lying Santa Cruz. \$119,000. (650) 326-1430 or ewhollandjr@aim.com.



62-FT TRANSOCEANIC-CLASS STEEL sailboat. All-weather comfort. Well maintained. Four private staterooms, three full heads, large salon, roomy pilothouse, sleeps ten. Well suited for eco-adventure travel. Many photos available. \$110,000. (503) 263-4988.

Latitude 38 eBooks

WORLDWIDE ~ JUST \$18/yr

www.latitude38.com

CLASSICS

WOODEN BEAUTY, 65' LOD KETCH. Marconi rigged. Traditional oak hoops on raked masts. Shallow draft. Sails nice and in great shape. See more at: <www.sunstarsail.com> or call (530) 467-3173.



1970 ALDEN CENTERBOARD YAWL. 54 feet, sailing luxury from a bygone era with modern updates. A restored world-cruiser vet, mahogany over white oak, beveled glass, carvings, mahogany interior, sleeps 8, dinghy, full cover. \$75,000/obo, as is where is. (510) 633-2125.

MULTIHULLS



CROWTHER 35 TRIMARAN. Racer/cruiser, set up for singlehanding. New paint 2008. 10-hp Tohatsu 2006. New nets 2004. Complete sail inventory, autopilot, wind and speed instruments, Garhauer vang, standing headroom, sink, stove. More boat than F-27. \$35,000. Call (818) 500-1631 or caresys@pacbell.net.

DEAL FELL THROUGH: CSK 50 catamaran. 1970 cold-molded construction, 80-hp diesel, radar, self-furling jib, 4 cabins, 2 heads. Located Berkeley Marina. Good condition. \$99,500. Call (925) 254-6404.



1973 HIRONDELLE 23 CATAMARAN. A solidly-built fiberglass catamaran with additional equipment for comfortable cruising. Roller furling, autopilot, windvane, self-tailing winches, Caribe dinghy, much more. 15" to 4' draft. Trailerable. \$18,900/obo. For a list of specs, equipment, more photos email: amvoyage@aol.com.

40-FT PILOTHOUSE KETCH. Modified Piver Victress trimaran. ProFurl, Isomat spars, full batten, EZ reef, lazyjacks, self-tailing winches. All lines aft, epoxy bottom, LPU topsides. Wing keel, new Edson steering, Perkins 85-hp diesel, keel cooler. Lotsa room, sails great. \$39,500. <<http://home.comcast.net/~captainado/madness/>> (707) 823-1149.

STARS AND STRIPES CATAMARAN. Dennis Conner's Formula 40, now 44-ft. Morelli design, carbon hull. Approx \$300k in 1988. Current \$100,000 value. Trade for cruising cat, tri. (775) 827-2786.

GEMINI 105MC CATAMARAN, 2005. Screecher, microwave, Furuno 1834C-NT 10.4" display, radar, GPS fishfinder, target tracking. Prosigne 2.0 inverter/charger. NewMar battery monitor. 200AH gel batteries, washdown pump, AB RIB/8-hp Honda 4-stroke, Fortress F28, Honda EU2000. Redwood City. (650) 380-3343 or brian.j.gibbons@gmail.com.

WINDRIDER 16 TRIMARAN with trailer, \$1,200. See: <www.windrider.com> for details. In Santa Cruz. (831) 475-4172.



26-FT CATAMARAN, 2000. 26' x 15'. Core cell construction, open solid bridgedeck, 9.9-hp 4-stroke electric start, sleeps 4, bimini with 3-sided enclosure. Located near Rio Vista, CA. Asking \$26,000. (916) 203-8517.

38-FT RACING TRIMARAN. Pro-built, Newick native. Wing mast, SSB, auto, Yamaha, dodger, excellent sails. Neeps paint. Steal at \$37,000. (775) 827-2786.



2004 BROADBLUE 46 CATAMARAN. Owner's version, air conditioning, young sails, electric winches, 10k generator, radar, chartplotter, 55-hp Volvo engines with approximately 1,500 hours each, solar, furling main, loaded with options. Currently in Ensenada, coming to California soon. \$520,000. (530) 417-6608. <www.dazlcat.com>

31'-LOA, 20' BEAM CATAMARAN boat-building project. Partially completed hulls and crossbeams for Jim Antrim-designed daysailer cat, could be converted to cruising cat or trimaran. Invested \$17k, unable to finish boat, need to sell as is. Duracore strip-planked hulls with carbon fiber layup inside, unfinished outside. 6" aluminum roller-bent crossbeams, some additional supplies, all for \$5,000 or best offer. Pics and more info: Stephen (707) 738-1813 or estebanbaja@gmail.com.

PRINDEL 19, 1989. High-performance catamaran in good sailing condition with galvanized trailer. Optional storage at Port of Redwood City, next to the ramp. Clean titles. \$1000/obo. Mike (408) 838-0331 or email: shinskym@mail.com.

POWER & HOUSEBOATS



65-FT WOOD CLASSIC, 1939. Heavy built ex-trawler. GMC 12V-71, 21-kw generator. Full electronics. Lots of equipment. Ready to go. Would make great conversion. More pics/details: ancona@mcn.org. Will consider any reasonable offer. Call (707) 964-5423.



1997 KEVLACAT 3400 FLYBRIDGE. Superior strength and lightweight due to use of Kevlar material. Twin inboard 315-hp Yanmar diesel engines. Catamaran hull tames the rough water and makes for very efficient fuel usage, even with a top speed of 30 knots. Full electronics in turnkey form with low hours, approx. 750. Health forces sale. See more specs, details and pictures at: <http://www.725regal.com> \$130,000. Please call (650) 364-4714.



32-FT CLASSIC MONTEREY. Totally restored Monterey fishing boat, converted to day boat, sportfisher or Bay cruiser. All woodwork has been done. New fuel tanks, hydraulic steering, tinted glass, etc. GMC 2-71 diesel engine. Needs to be finished, such as controls, wiring, exhaust and finishing touches. Must be seen to be appreciated. Will consider any reasonable offer. Pics/details: (707) 964-5423 or ancona@mcn.org.



1995 RENDOVA 19 RIB dive boat with 1996 Mercury Offshore 150 2-stroke, 25-gallon fuel tank. Tubes 2003 from Wings inflatables, hookah dive compressor. Runs great, fun boat. Alameda. Asking \$16,000. (415) 302-0101.



57-FT CHRIS CRAFT, 1964. Twin GM 8V71Ns, 10-kw Kohler, 3 heads, 2 showers, LectraSan, Alwgrip on hull, sleeps 12 in 6 separate areas. Freshwater and covered berth since 1980. 2 Sub-Zero refrigerators, 1 Sub-Zero freezer with ice maker. Full delta canvas. Would make a great liveaboard. Make offer. Call Rex (925) 833-7121.



CHRIS CRAFT 28 CATALINA EXPRESS cruiser, 1977. Great family boat. Sleeps 6, VHF, depth, windlass, 6'5" headroom, repowered with 80+ hours. Berthed at Vallejo Marina. Must sell. \$10,000 \$8,000/obo. (707) 486-9647.



1982 CORRECT CRAFT FISH Nautique. Repowered with new 285-hp Pleasure Craft fuel-injected engine with 280 hours. Teak swim platform, color chartplotter/GPS/sonar, VHF, bottom paint, newer aluminum trailer and fresh (in water) flush system. 40-mph boat. See: <http://picasaweb.google.com/taylor.stein/1982_correct_craft_fish_nautique> \$15,000. Call (415) 518-8550.

16-FT SKIFF, 2005. Cold-molded cedar, fiberglass sheathing. Top speed 17 knots, cruise 7 knots and get 13 mpg with 15-hp Honda outboard. Beautiful, quiet and efficient. Includes Pacific galvanized trailer and bimini top. \$16,500. John (510) 366-1476.



PRICE REDUCED. 30-FT WILLARD Vega Searcher. Excellent little ship for 2, good for 4. Super condition in/out. All systems in excellent condition. Full electronics. All safety gear, full head, 100 gals fuel, 100 gals water. See to appreciate. Call (650) 207-6898 or (650) 851-3402.



1972 CRUISE-A-HOME HOUSEBOAT. Sleeps 4. Galley, pressurized water, head, shower, swim platform, screens. Generator, stereo, VHF, microwave, electronic ignition on twin 300 hp OMC V8s, new outdrive, new canvas. 11+ knots. Comfortable, seaworthy. Pictures: <www.deltadrifter.com> \$14,500/obo. (916) 777-5510.



STEEL TRAWLER YACHT under construction. 57' x 15'3" x 6'3" hull, steel work 99% complete. Interior partially finished. Located in Bay Area, can be seen by appointment. (510) 219-1463 (lv msg).

PARTNERSHIPS

COLUMBIA 34 Mk II, 1972. Nice classic boat, well equipped for day-sailing or cruising. Wheel steering, furling jib, new interior cushions. Unlimited non-equity use, \$400/month to cover slip fees at Alameda Marina, insurance and taxes. (510) 521-1062 or (510) 316-0594 or b.bostrom@yahoo.com.

PROFESSIONAL YACHT DELIVERIES

60 years of combined experience • 100,000 miles at sea • USCG Licensed
Capt. Phil Howe (415) 290-1659 • Capt. Greg Snead (415) 846-6919
We'll get the job done in a safe, professional manner • Call for details

**FREE
 Catalog**



Defender®

The BRANDS you WANT and TRUST
 in STOCK for LESS

(800) 628-8225 • www.defender.com

Learning to sail is a breeze with ...

SailingWindWheel.com



COMPLETE MARINE WOODWORK

Design / Restoration • Expert European Craftsmanship • Interior / Exterior
 Repairs / Maintenance • Marine Windows & Frame Replacement
 Wood & Dry Rot Repairs • Varnish Work • Marine Painting
 References Available • Reasonable Rates • Call (415) 331-6718



MALACHOWSKI & ASSOCIATES
Attorney At Law

Boating DUI Defense Lawyer

Boating under the Influence of Alcohol
Collisions, Right of Way Violations
• USCG Issued Mariner's License / MMD (Z-Card)
Suspension and Revocation (S&R) Hearings
• OCM Determinations

www.marklawdui.com
Tel: **(415) 983-0717**

PARTNERSHIPS, CONT.

CATALINA 30 SHARE. Best Sausalito slip with parking. 5 min. to Bay, 30 to Angel Island. Walk to bars/restaurants. Upgrades: Wheel, diesel, cushions, jib furler, mast, more. Non-equity use 7 days max/month. 1 year, \$270/month. (415) 332-5442 or Leeloves2sail@hotmail.com.

WATKINS 36C. PARTNERSHIP in spacious 36-ft center-cockpit sloop and slip at Pier 39 in San Francisco. Well maintained. Original owners. For cruising the Bay or passage to Mexico. No liveaboards please. shboatmail-bay@yahoo.com or call (650) 224-8020.

BENETEAU 393. Sausalito downtown berth. Beautiful, fully equipped, well-maintained, fast cruiser. Full electronics, diesel, dinghy, outboard. Like-new interior. Classic main, furling jib. Prefer active sailors. Non equity \$500/mo. (415) 847-4716 (cell) or greg@marigotgroup.com.

CAL 31 PARTNERSHIP. Well-maintained boat. Santa Cruz Lower Harbor berth. \$5,000 equity/\$175 per month. Or possibly no equity/\$250 per month. 25% share. Easy-going, financially responsible sailor with some experience only. Call Mike (831) 425-5583 (eves) or email: msail@ix.netcom.com.

ONE-THIRD TIME SHARE IN Catalina 30 sloop. New sails, repowered with 24-hp Yanmar, wheel steering, original owner, clean, easy daysailer. Located San Francisco. \$350/mo. (415) 731-4956.

PEARSON TRITON 28 SLOOP. Excellent condition, 15-hp Yanmar inboard, 5 sails, head and galley, sleeps 4. Sausalito slip. Congenial partners, non equity. \$125 per month. (415) 459-7417

BUYING RENTING OR BUILDING in Barra De Navidad, Mexico? Let me help with obtaining permits or finding apartments or houses. Laura Murillo Hogin: ggato18@yahoo.com.mx.

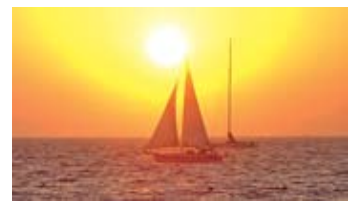

PRIVATE CHARTERS, FULL AND half-day. Overnight can be prearranged. Review our charter options or contact us to individualize your itinerary and special day. Make your vacation to Puerto Vallarta a lasting memory. <www.seagnomeadventures.com> Call Mex: 011-52 (322) 134-7397 or US: (714) 412-6180 or email: info@seagnomeadventures.com.

PLAN YOUR MEXICAN GETAWAY NOW at the brand-new, gorgeous Cielo Y Mar condos. Located in Punta Mita, 35 minutes from Puerto Vallarta, available to rent from private owner. Right on the beach, 10 feet from the water, they offer spectacular views of ocean and mountains, the biggest infinity pool in the area, an endless beach, great advanced and beginning surf breaks, great fishing, tremendous views of whales, bird life and the islands. While uncrowded and tranquil, it's just a five-minute walk to several waterfront restaurants. Choose from a spacious and beautifully furnished one or three-bedroom unit, or an amazing two-story penthouse with lovely shade trellis on the top floor. See details: <www.puntamitabeachfrontcondos.com> To reserve, call (415) 599-5012.

WANTED

WANTED: VANCOUVER 27. Email: lumanmoody@yahoo.com.

NEED HELP TO MAKE AN OLD BOAT go. Low on cash. Need sails. 1965 Magellan 36. Jib 39' x 14', main 35' x 17' or close. (530) 318-3754.

GIVENS 4/6 MAN OFFSHORE with canister and cradle. S/S port lights 12" x 5" opening approx. Aerogen #3/#6 wind generator. John (808) 291-3233 or AEOLUS_99@yahoo.com.

TRAILER FOR CAL 22 fixed keel at Lake Tahoe. Trailer must be road-worthy for transport to/from Reno. Call Joe (775) 971-0113 or (775) 560-7609.



SOUTH OF THE BORDER

LEARN TO SAIL in the Sea of Cortez. San Carlos Sailing School, an ASA school based in San Carlos, Sonora. Specializing in learn-to-sail cruises, vacations. Also offer boat rentals, day trips. See: <<http://mexicosailing.com>> or please call (800) 874-4830.

CONDO RENTALS NEAR VALLARTA yacht club. Two adjacent condos overlooking Paradise Village Marina. Each 2 br, 2 bath with Jacuzzi, pool and amenities. Access to Sports & Beach Club. Rent one or both. Call (925) 208-1601 or 011-52 (322) 297-7559 or nancywmoore1@aol.com.



LEARN OFFSHORE NAVIGATION

From Celestial to GPS and Electronic Charts
Course on CD • Instructors via Email
www.amwnavigator.com

OFFSHORE PASSAGEMAKING INSTRUCTION IN THE ATLANTIC
John & Amanda Neal are dedicated to providing hands-on, documented instruction aboard their Hallberg-Rassy 46 *Mahina Tiare III*, drawing on their combined 472,000 miles and 63 years of experience.
www.mahina.com • (360) 378-6131



We care about sail care!



San Francisco Service
773 Andersen Drive, San Rafael, CA 94901
T: 415-453-2142 M: 510-333-4644
Hours: 8-5 M-F, Sat. by appointment
Faster by Design
www.northsails.com
SAIL CARE ■ SAIL COVERS ■ YACHT COVERS ■ FLAGS ■ CRUISING PRODUCTS



PRIME FABRICATION.
Marine Hardware and Custom Metal Fabrication

- Stainless Anchors - Plow, Fluke, Claw & Ace
- Table Pedestals • Flopper Stoppers
- Helm Seats • Handrails



Ph 949.496.1348
Fax 949.496.1341
www.primefabrication.com
33081 Calle Perfecto, Suite B
San Juan Capistrano CA 92675



MARINA DE LA PAZ FULL SERVICE MARINA
S.A. DE C.V.

Friendly, helpful, fully bilingual staff

All new hardwood docks • Wireless Internet
Dinghy landing with potable water
New protective piling & sheetpile breakwaters • And more!

TEL: 01152 612 122 1646
email: marinalapaz@prodigy.net.mx
www.marinelapaz.com
Apdo. Postal 290, La Paz, 23000, Baja California Sur, Mexico



TRAILERS

2000 ZIEMAN TRIPLE-AXLE TRAILER. Used previously with Sea Ray 260 Sundancer. \$3,000. (510) 325-1039 or mcvullin@gmail.com.

2000 HOSKING NEW ZEALAND 28-FT Protector boat trailer. Very low mileage, dual-axle, 40 rollers, electric brakes, 7,500 lbs, spare tire, jack. Sitting for 7 years without boat on it. Over \$6K new. \$3000/obo. (408) 398-4251 or email: mcoleman50@hotmail.com.

SAILBOAT TRAILER. Single-axle, rated for 6,000 pounds. I wasn't comfortable with my Catalina 27 on it but it would carry a 25 nicely. \$1,000. Shoot me an email, I'll shoot you a picture. Stagesop9472@sbcglobal.net or (707) 277-0915.

GEAR

45-LB CQR ANCHOR. \$560. Please call (415) 665-6269.

35-LB ABI PLOW ANCHOR, \$100. Davis Mk 15 sextant, \$80. New Revere Offshore Ocean 4 liferaft, \$1,800. McMurdo 406 EPIRB, \$250. Sea222 SSB radio, \$200. Photocomm Dum50 solar panel, \$240. New Vetus LP Waterlock muffler, \$50. Steve (707) 895-2813.

NORTHERN LIGHTS DIESEL generator, 5-kw freshwater-cooled with control panel, only 34 hours of run time since new. All that's needed is a boat and a battery. \$5,000 (save \$5,500). Don (415) 454-0170.

MY TRAINED COCKROACHES want to sell you an Atomic 4 rebuild for \$2,950, or a Westerbeke 13-hp diesel at \$2,200. Both complete and ready to install by me for \$\$\$\$. Instead of buying a smart car, have a smart boat. (415) 272-5776.

PFaff 130 SEWING MACHINE. Straight/zig zag, with case. \$300. (541) 597-4373 or stevestock@frontiernet.net.

TINKER 12, TRAVELLER SAILING dinghy/liferaft. Luke LK70 storm anchor. Code-0 sail. ParaTech 15 sea anchor plus line. Phaff sewing machine. PUR 6 and 15 watermakers. East Coast OG and Maptech charts. CQR45 anchor. Abandon-ship bags. (817) 301-9127 or sonrisa249@aol.com.

SAILS AND LIFERAFT from Santa Cruz 50. #3 racing, excellent condition, \$2,400. Mains, spinakers and headsails, good to fair condition, make any offer. Recut for your boat. Liferaft: 10-person Plastimo Offshore, \$1,500/obo. (650) 492-0681 or captkirk@sfbaysail.com.

GENOA 885-SQ.FT., 9.3 HIGH modulus Dacron, excellent condition, only used a few times, \$850/obo. Selden Furler 300S headsail furling system, about 62-ft, excellent condition, only used a few times, \$1,900/obo. (530) 417-6608.

SOLID VANG, 35 TO 40-FT BOAT. \$350. Davis Mark 25 sextant/starfinder/tables, \$120. Wetsuit, 2XL, hood/gloves/shoes, \$80. F/W gear, men's, used, \$40; woman's L, new, \$100. Edson outboard bracket, new, \$150. Call (541) 514-3810.

PLASTIMO COASTAL-6 LIFERAFT, Avon inflatables: RU-315, Redstart, Redcrest, mounts, pumps, seats, oars. Achilles SPD-4, 2.5 to 8-hp outboards, Alpha 4000, Autohelm 3000/4000 parts, Tillermaster, paranchor, drogue, Lewmar 2000 windlass, hatches, BBQ, Velvetdrive, vdrive, compasses, Davis 25 sextant, bow roller, davits, winches, scoops, headsails. brad-low@sbcglobal.net or (415) 497-3731.

74-FT MAST DESIGNED for catamaran. Best offer. (415) 269-5165.

MISCELLANEOUS

MARINE FLEA MARKET / MARITIME Day Celebration: Sausalito, 300 Napa Street. Saturday, August 2, 8 am - 6 pm. Festivities include: Flea market, maritime skills demonstrations, art, live music, food, boat rides and more. Bring the whole family. Spaces available. \$35. <www.galileeharbor.org> (415) 332-8554.

18th ANNUAL FLEA MARKET, VALLEJO Yacht Club, 485 Mare Island Way, Vallejo. August 30, 9 am - ? Join us for fun, food, bargains. Buy, sell, browse. If it's legal, sell it. Vendors welcome, \$25/space. Call office (707) 643-1254.

CAPTAIN'S LICENSE CLASSES. OUPV (6-pack)/100-ton Masters, plus towing and sailing endorsements. USCG-approved courses. Successful completion satisfies USCG exam requirements. Offered by US Maritime Academy of California. Weeknight classes in San Mateo. Call Mike (650) 298-9489.

CLUBS & MEMBERSHIPS

CLUB NAUTIQUE MEMBERSHIP. Includes all classes leading to offshore passagemaking. Discounts on seminars, classes and charters. \$3,000/obo. Carey (510) 552-1989.

CLUB NAUTIQUE SAILING CLUB Membership. Selling the single Passage Maker membership for \$3,000. Fantastic club. I got married and my wife doesn't want to sail. What can I say? Includes all Basic membership benefits. Call Bill (925) 989-2425.

SINGLE SKIPPERS AND CREW of all abilities are invited to attend Single Sailors Association's <http://www.singlesailors.org/> meeting held 2nd Thursday, Oakland Yacht Club, 1101 Pacific Marina, Alameda, 94501. Social 6:30 pm. Meeting 7:30 pm. Members enjoy daysailing, rafts and social events. Guests welcome. (510) 233-1064.

CLUB NAUTIQUE ULTIMATE membership. All sailing and powerboat classes included. <http://www.clubnautique.net/sailing/membership/types.html> \$7,250 if purchased from the Club. Great deal at \$6,250. Moved out of country. Email: vidalibre@keef.com.

NON-PROFIT

MARIN POWER & SAIL SQUADRON offers members free classes ranging from Seamanship to Celestial Navigation plus cruises and social events. Next Squadron Boating Course in Novato September 9, 11, 16, 18, 23, 25, 2008, all from 7 to 9 pm. Textbook \$50. For details and registration call (415) 924-2712.

SAFE BOATING NO ACCIDENT. Santa Clara Power Squadron promotes safe boating. Boat Smart Class: Wilcox High School, 3250 Monroe, Santa Clara. Classes are four Tuesdays, starting September 30, 2008, 7-9 pm. Cost \$30 for materials. Call (408) 225-6097.

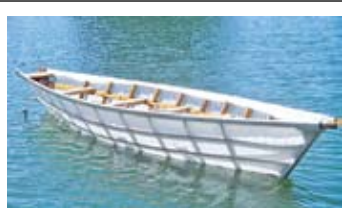

SKIN-ON-FRAME BOATBUILDING workshops. Build your own sea kayak in 4 weekends. Build a 25-ft sailboat in 7 days. Commission a boat, design your own class or check our website for currently scheduled programs: <www.WatersideWorkshops.org>

PROPERTY SALE/RENT

SUMMER VACATION BY THE BAY. Tiburon condo. 2 bdms/1 bath. Queen in master, twin-size loft bed in kid's room. Close to sailing and other Bayside recreation, SF, wine country, beaches, bike path, hiking. Kid-friendly, quiet, nice, convenient neighborhood. \$595/wk or \$350/3 nights, + deposit. See: <www.digsville.com/listing_photos.asp?id=34> Chris (415) 383-8200 x103 or chris@latitude38.com.

BERTHS & SLIPS

OWN YOUR OWN SLIP IN EMERYVILLE, CA. This is not a 'right-to-lease' fee, this is a 'real estate' purchase. You own the slip. Dual fingered, 45' x 14.5' slip, beautiful marina, very protected, on Bay. All amenities provided, \$59,850. David (831) 818-4206.

PIER 39 BOAT SLIP available for rent. 40 feet, D-dock, away from the sea lions. Great location in the heart of San Francisco, beautiful views, great marina facilities, parking available. \$350 per month plus utilities. Call Frank (206) 321-3730.

FOR SALE: 36-FT, PIER 39. B25. Lowest price. (714) 310-0659.

PERSONALS



TALL, WARM, FIT, BERKELEY resident seeks first mate to cruise SF Bay and the Delta in his Ericson 30. I would like to meet a warm, upbeat, fit woman, late 50's/early 60's, for sailing, friendship and a romantic relationship if the chemistry is right. If you like to sail and have the time and energy to enjoy life, let's talk. (510) 704-0772.

TRYING TO LOCATE

DÉJÀ VU, 36-FT STEEL SAILBOAT, built Sausalito 1978, Bob's Boatyard. Chine hull, Goit winches, hydrovane. Call (707) 895-2813 or derwinski@pacific.net.

JOB OPPORTUNITIES

SAILING AND POWER BOATING instructors wanted. Award-winning Club Nautique is seeking instructors with exceptional boating and communication skills to teach in Alameda and Sausalito. We have the newest fleet on the Bay and the most active Coastal Passage Making program in the nation. Advance your skills, work with other professional instructors and have fun on the water. Includes boat use privileges and membership benefits. CG License required. Call Jim Hancock (510) 865-4700 or email: jhancock@clubnautique.net.

BLUE PELICAN MARINE

A sailor's consignment store now open at Grand Marina, Alameda
Sails • Winches • Instruments • Brass • Collectibles • Sailing Books
Charts • Small Outboards • Hardware • No large items • No junk
(510) 769-4858 • bluepelicanmarine@sbcglobal.net

SEGWAY OF OAKLAND

212 International Blvd., Oakland • Rent, buy, or lease
All models in stock • New & Used • Only \$55 for a lesson
(510) 832-2429



WINCHMATE
SELF-TAILING CONVERSION

www.winchmate.com

For Barient & Barlow #27 - #32

(415) 460-5151

Need Crew? Latitude 38 Crew List *A Boat to Crew on?*

Visit our website and sign up as Skipper or Crew • It's Free
Find out about our next Crew Party: Wed. Sept. 10 at Encinal Yacht Club
More info: www.latitude38.com/crewlist/Crew.html or call (415) 383-8200

Mathiesen Marine Services

For All Of Your Electrical & Electronic Needs

- Systems Design & Troubleshooting
- Marine Electronics Installation
- PC & Mac Based Navigation Systems
- AC/DC Electrical Panels/Systems
- Chargers/Inverters/Solar Panels
- Battery Bank Testing/Upgrades



(510) 350-6622

www.MathiesenMarine.com

-Fully Insured-

environmentally friendly products



- ◆ No harsh chemicals
- ◆ Organic composting
- ◆ No thru-hulls
- ◆ Only \$850 - includes hoses, brackets, fan



Nature's Head Composting Toilet

(530) 383-4217

www.greenpease.net

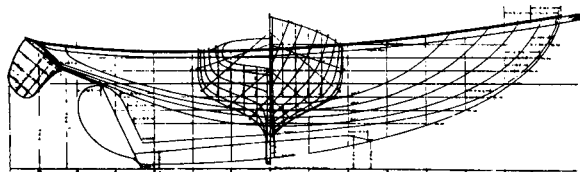

MAKELA BOATWORKS

Family owned since 1948

Wooden Boat Building • Repair and Restoration

19280 South Harbor Drive • Fort Bragg, CA 95437

(707) 964-3963

email: howard@makelaboatworks.com • www.Makelaboatworks.com



2008 NISSAN OUTBOARDS

NSF 3.5 AI	3.5 hp 15"	\$962
NSF 8A31	8 hp 15"	\$1,664
NSF 15B21	15 hp 15"	\$2,200

TLDI TWO STROKE ENGINES

NSD 90BEPT02	90 hp 20" fuel injected	\$7,544
NSF 115AEPT02	115 hp 20" fuel injected	\$8,300

Controls & 3-year warranty included. 20% off product and/or labor to veterans.



Now offering 14.5' hand-laid ocean kayaks.

265 Gate 5 Road • Sausalito, CA 94966

(415) 332-8020

JOB OPPORTUNITIES, CONT.

CAPTAINS, FIRST OFFICERS & CREW.

Rendezvous Charters is hiring ship's crew and licensed masters to sail our fleet of five certified vessels, including our 77-passenger schooner, *Bay Lady*. Part-time or full-time. Excellent wages/benefits. Mid-week and weekend work available, flexible schedule. Want to enjoy your job? Building your sea time? Join this rapidly growing company. Great people, fun company. Fax résumé to (415) 543-7405 or call (415) 543-7333.

BUSY CHARTER COMPANY needs part time help checking clients in and answering phones. Ideal candidate would know boats and/or the charter trade. Weekends a must. (415) 331-0444 or email: info@sfbayadventures.com.

6-PAK CAPTAINS AND SAILING instructors, Spinnaker Sailing in San Francisco, is hiring sailing instructors and captains for part-time or full-time work in the City aboard our fleet of 22 to 44-ft sailing yachts. Mid-week and weekend work available, flexible schedule. This company is growing fast for one reason ... its people. Fax résumé to (415) 543-7405 or call (415) 543-7333.

TOO LATE TO CLASSIFY

CORONADO 27, 1973. Fiberglass, sails great. Good 6-hp longshaft outboard, great mileage. Sausalito, CA. \$2,999. Call Jerry (406) 899-2789.

CHRYSLER 26, 1978. New 9.9 Mercury outboard with controls plus 2-year warranty. New cushions, clean interior VHF, depth/fishfinder, steering column. Sails in good condition. \$6,200. (510) 919-6960.



PEARSON TRITON 28.5, 1962. 1st place Classic winner So-Bay OP-Day, 2006. 18-hp Yanmar, freshwater cooled. 7 sails including spinnaker. Barient, autopilot, standing headroom. Haulout 4/05. Located Redwood City, CA. (650) 327-0190. Will email photos: cdroth2@sbcglobal.net. Reduced to \$9,500. Certified check only.



50 X 26-FT TRIMARAN. Fiberglass over wooden superstructure. 5 berths, 4 queens, 1 king, hot and cold shower, commercial Westerbeke 4-cylinder diesel, runs good. Mass will be stood upon completion of sale. Includes dinghy and 10-hp motor. \$44,000/obo. Call Alex (916) 247-4017.

NORDIC 44, 1982. Sloop rig. Bob Perry design, roller furling. Fully battened mainsail. Sausalito berth. \$169,000. See pics: www.yachtcharter.com Call Joanna (415) 332-0800 or atlantis@yachtcharter.com.



LYLE HESS 30, 1997. Classic wooden Bristol Channel cutter. 2 times Wooden Boat Show winner, San Diego Yacht Club. Now for sale in as-new condition. Located Monterey, CA. View on web: www.watsonvilledentalclinic.com Asking price \$135,000. Call (831) 254-7001.



Let Your Boat Make Money • Charter It

NEW and HUGE TAX BENEFITS
www.spinnaker-sailing.com

Spinnaker Sailing • South Beach Harbor, SF • (415) 543-7333



Going Somewhere? **Mexico • Caribbean • South Pacific**

Stop by our office and take a bundle of *Latitude 38* along with you.

We promise you'll be a hero for sharing them with other cruisers!

Latitude 38 • 15 Locust Ave • Mill Valley, CA • (415) 383-8200 • Open M-F 9-5

MARINE ENGINE CO.

PERKINS • YANMAR • ATOMIC 4 • VOLVO
WESTERBEKE • UNIVERSAL • BETA MARINE

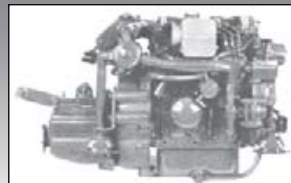

CALL NOW FOR LOW ENGINE QUOTES

- Engine Repowering and Rebuilding
- Engine Sales, Service and Parts
- Complete Marine Engine Service

(415) 332-0455

weatherguy.com

Worldwide Marine Forecasts
Cruising, Racing & Commercial
 Packages Starting at \$50.00 USD

(866) 882-WXGY (9949) toll free
 (808) 291-WXGY (Mobile)
 (808) 254-2525 (Office)
 (808) 254-1525 (Fax)



970 N Kalaheo Ave
 Suite C-109
 Kailua, Hawaii 96734
 info@weatherguy.com

www.weatherguy.com

GC Marine

- Custom line for racers and cruisers
- Standing & running rigging
- Roller furling installations
- Fiberglass, carbon, gelcoat repairs
- Lifelines swaged on location

Free estimates - Unmatched rates

gilles@gcmarine.net 415-533-2915

¿ MEXICO BOUND ?
DON'T LEAVE PORT WITHOUT

GERRY
 SEA of CORTEZ CHARTS

YOU DON'T NEED A BIG BOAT
GET A COPY OF GERRY'S
Trailer Boating the Sea of Cortez

www.gerrycruise.com

WIRELESS E-MAIL



ICOM **SCS**
 the factor creators

SeaTECH SYSTEMS™
 Computerized Navigation & Communication
800.444.2581 • 281.334.1174
 info@sea-tech.com www.sea-tech.com

Call for Info on SeaTech Packages & CAPN Demo Disk

BDI
MARINE SURVEYS & DELIVERY CAPTAINS

Book Your Boat's Return from the Pacific Cup
 Pre-purchase and Insurance Surveys
 Serving the Entire West Coast
 More than 100,000 Miles at Sea
 30+ Years of Experience
 Power and Sail

(707) 526-2418

Dare to be Different!

SOVEREIGN
 BBQ & GRILLS
 AUSTRALIA



Quality Features Include:

- Seamless 316 marine grade stainless steel, beautifully finished
- Flame failure safety device, baffled air intake, easy clean drip tray
- Flat plate or grill/flat plate combination
- Two sizes available, suitable for boats from 20 feet onwards
- Standard mounting options to suit powerboats and sailboats
- Great for transom rails on sports cruisers
- Accessories include beach stands, covers and trays

Call for your local dealer, or for a free color brochure. **714-843-6964**
 email: sales@quickline.us www.quickline.us

ADVERTISERS' INDEX

AB Marine.....98	Baja Ha-Ha Sponsors..... 19,20,21	Berkeley Marine Center59	Bottom Siders..... 219	Corsair Marine42
ABC Yachts..... 226	Ballena Bay Yacht Brokers.....17	Beta Marine Engines 156	Brisbane Marina95	Cover Craft.....85
Agape Villages..... 208	Barillas Marina 192	Blue Latitude Press.....93	British Marine16	Coyote Point Marina61
Almar Marinas77	Bay Island Yachts 220	Blue Sky Energy 196	Butler Rigging 217	Cruising Cats USA95
Alpha Marine Systems..... 143	Bay Marine Boatworks63	Blue Water Marine Paints/ National Paint Industries.....89	BVI Yacht Charters 179	Cruising Direct Sails.....50
Anacortes Yacht Charters..... 179	Bay Marine Diesel..... 219	Blue Water Yacht Insurance.....78	Cal Marine Electronics.....33	Cruising World Pacific..... 221
Anderson's Boat Yard57	Bay Risk Insurance18	Bluestorm99	Catalina Yachts23	Cruising Yachts9
Annapolis Performance Sailing 152	Bay View Boat Club 167	Bluewater Network..... 220	Chula Vista Marina 134	CYOA Yacht Charters..... 176
Antioch Marina.....49	BDI Marine Surveys..... 215	Bo'sun Supplies 219	City Yachts..... 34,35	Davis Instruments 148
Aqua Marine..... 197	Bellhaven Yacht Sales & Charters 178	Boat US..... 170	Club Nautique70	Desolation Sound Charters 179
Aquatic Protection Agency..... 221	Berkeley Boat Sales 220	Boat US Insurance..... 157	Coast Marine..... 204	DeWitt Studio 219
Bair Island Marina32	Berkeley Marina.....71	Boatswain's Locker.....91	Colligo Marine..... 197	Diesel Fuel Filtering 208
			Conch Charters..... 177	Dockwise Yacht Transport55

"Latitude 38 is the Best of the Bunch"

"I am living and working on the Sunshine Coast south of the Whitsunday Islands. I've been reading Latitude 38 since the early 1980s. I've seen a lot of sailing publications from various areas and countries, and frankly, Latitude 38 is the best of the bunch. There's only one Latitude 38. Whenever I'm in the U.S. I grab a few copies and pass them to sailing friends who inevitably say the same thing: Wow, this is a great sailing magazine for cruisers!"

– Jim Otterson, Australia

Latitude 38 eBooks

AVAILABLE WORLDWIDE – JUST \$18/yr

www.latitude38.com

ADVERTISER'S INDEX - cont'd

Downwind Marine	82	Flying Tiger Yachts	169	Greenpeace.....	214	Hydrovane	200	Leukemia &	
Doyle Sails	39	Forespar.....	85	H.F. Radio.....	153	Isotherm / Indel	40	Lymphoma Society	41
Easom Rigging.....	210	Fortman Marina.....	36	H&S Yacht Sales.....	13	Jeanneau America	8	List Marine Enterprises.....	206
Elliott/Pattison Sailmakers.....	87	Fridge Freeze.....	89	Hanse North America	153	JK3 Nautical Enterprises.....	67	Loch Lomond Marina.....	130
EM Designs	220	G.C. Marine Services.....	215	Hansen Rigging	82	Johnson Marine, C. Sherman.....	84	Makela Boatworks.....	214
Embroidery Factory.....	219	Garhauer Marine.....	73	Harken	80	Kensington Yachts	222	Malachowski & Associates.....	212
Emery Cove Yacht Harbor.....	85	Gentry's Kona Marina.....	218	Helms Yacht & Ship Brokers/ West Coast Multihulls	43	Kissinger Canvas	16	Marina Bay Yacht Harbor.....	47
Emeryville Marina	149	Gerry Sea of Cortez Charts ...	215	Helmut's Marine Service	220	KKMI - Brokerage	69	Marina de la Paz.....	212
Essex Credit Corp.	131	Gianola & Sons	206	Heritage Yacht Sales.....	222	KKMI - Maritime Services	45	Marina El Cid	192
Euro Marine Trading	88	Glen Cove Marina	168	Hogin Sails.....	60	Landfall Navigation.....	97	Marina Puerto Salina	198
Fago, Margaret Artist.....	91	Golden State Diesel Marine ...	210	Hood Sails.....	65	Landing School, The	143	Marina Puesta del Sol.....	193
Farallone Yacht Sales	7	Grand Marina	2	Hotel Coral & Marina.....	135	Larsen Sails/Neil Pryde Sails ...	74	Marina Real	200
Flying Cloud Yachts.....	15	GreenBoatStuff.com	218			Lee Sails.....	208	Marina Riviera Nayarit	51

STANDING RIGGING REPLACEMENT

AT YOUR SLIP!!

Ask About Lifeline Replacement
Cruise/Race • One Design Fleet Specials

BUTLER RIGGING

(510) 672-2639

butlerrigging@sbcglobal.net



ATLANTIC 57 CATAMARAN™



THE ORIGINAL PILOTHOUSE CATAMARAN
 o Designed for easy shorthanded cruising
 o Spectacular windward performance
 o Cored epoxy/glass/carbon construction
CHRIS WHITE DESIGNS
 TEL: 508-636-6111
 www.chriswhitedesigns.com

WEDLOCK, RAMSAY & WHITING

Marine Surveyors



Pre-purchase, insurance: vessel, engine, rig surveys

Serving the Bay Area since 1980

www.norcalmarinesurveyors.com

(415) 505-3494

NEW AND USED SAILS!
 Specializing in production boats and featuring the largest selection of stock sails available anywhere! Save with warehouse volume discounts on Stock Sails, Custom Sails, Sail Covers, Furlers and Accessories. All top Quality.

FAST SHIPPING!

All Fully Guaranteed!

- Full Batten Mains
- Furling Genoa's
- Storm Jibs
- Trysails
- Furling Units
- Custom Canvas
- Used Sails

FREE CATALOG!

THE SAIL WAREHOUSE
 Ph. (831) 646-5346 www.thesailwarehouse.com

SAVE YOUR FUEL!

Fuel Polishing

Tank Cleaning



Www.MarineLube.biz



From our boat to yours, we bring the SERVICE to your slip!

RPARTS

REFRIGERATION PARTS SOLUTION

100% INTERNET BASED We carry a complete line of refrigeration parts for maintenance, repair, and upgrades for all brands including Grunert, Glacier Bay, Marine Air, Sea Frost, Adler/Barbour and more. We are also



pleased to offer R28+ vacuum insulation panels (independent lab tests) all at Rprices: guaranteed lowest!

www.rparts.com

ADVERTISER'S INDEX - cont'd

Marina Village.....31	Mission Creek Sail Tours/ SF Sail Tours 178	Outboard Motor Shop..... 86	Punta Mita Beachfront Condos 180	Sailtime62
Marine Engine Co..... 214	Modern Sailing Academy.....99	Owl Harbor..... 124	Pusser's Rum6	Sal's Inflatable Services.....91
Marine Lube 217	Napa Valley Marina64	Oyster Cove Marina.....16	Quantum Pacific 26,27	San Francisco Boat Works 171
Marine Outboard Co. 214	Nelson Yachts 224	Oyster Point Marina..... 158	Quickline..... 215	San Juan Sailing 177
Mariner Financial Services.....81	Nelson's Marine..... 228	Pacific Coast Canvas.....83	R-Parts 217	San Leandro Marina79
Mariner's General Insurance.....66	New Era Yachts..... 223	Pacific Yacht Imports.....11	Raiatea Carenage Services.... 199	Santa Cruz Yachts25
Maritime Institute.....24	Norpac Yachts 227	Pacific Yacht Management..... 178	Randall Burg Yacht & Ship..... 224	Sausalito Yacht Club Junior Sailing97
Marotta Yachts..... 225	North Beach Marine Canvas.....33	Paradise Cay Yacht Harbor.....38	Richardson Bay Marina..... 204	Scan Marine Equipment 149
Mathiesen Marine..... 214	North Sails 212	Passage Yachts.....4,5	Rooster Sails.....93	Scanmar International 134
Mazatlan Marine Center/ La Paz Yachts.....14	North Sails - San Francisco.....58	Pier 32 Marina/Harbor Island West Marina..... 201	Sail California 28,29	Schmidt, Charlotte Yachts..... 223
McDermot Costa Insurance 131	OnlineMarineStore.com.....81	Pineapple Sails3	Sail Warehouse, The 217	Schoonmaker Point Marina.... 142
McGinnis Insurance..... 166	Opequimar Marine Center 194	Prime Fabrication..... 212	Saildawg.com.....99	Sea Hawk/New Nautical Coatings.....56
Milltech Marine Inc.....72	Orange Coast College.....75	Puerto Lucia..... 195	Sailrite Kits76	

Latitude 38's Mexico-Only Crew List & Baja Ha-Ha Party

**WEDNESDAY
SEPTEMBER 10**

6:00 to 9:00 pm

(Please, no early birds!)

ENGINAL YACHT CLUB

Pacific Marina, Alameda

**FREE for 2008 Baja Ha-Ha Skippers
& First Mates only**

\$7 at the door for everyone else
(Exact change very helpful!)

*Munchies • No-Host Bar
Door Prizes • Demonstrations
Guest Experts*



For directions and more info, see our Web page at

www.latitude38.com/crewlist/Crew.html or call us at **(415) 383-8200**



www.greenboatstuff.com

Environmentally Friendly Boating Supplies



Call us toll free at
(866) 535-1610
or visit us online

www.greenboatstuff.com

FEATURED PRODUCTS

- Anti-Fouling Paint
- Sunscreen
- Clothing & Linens
- Bags & Buckets
- Cleaning Supplies
- Hardware
- Galley Gear & Food
- Personal Care Items
- And Much More!

HAWAII

LONG TERM DRY STORAGE

Clear Customs at our dock

**GENTRY'S
KONA MARINA**

HONOKOHAU HARBOR

156°1'30" W
19°40'20" N

888-458-7896
TOLL FREE

The friendliest boatyard in Hawaii

ADVERTISER'S INDEX - cont'd

Sea Scouts..... 210	Star Marine Electronics.....87	Tradewinds Sailing 159	Wedlock, Ramsay & Whiting Marine Surveyors..... 217	Yachtfinders/Windseekers.....18
Seashine 135	Starbuck Canvas.....18	Trident Funding.....10	West Marine - Baja Ha-Ha 125	Tell 'em <i>Latitude</i> sent you!
Seatech 215	Surface Restoration Group..... 149	UK-Halsey Sails54	West Marine..... 90,92,94,96	
Seawear Nautical Jewelry46	Svendsen's.....37	Ullman Sails53	West Marine - Rigging30	
Selden Mast, Inc. USA.....22	Svendsen's Marine52	US Sailing 153	Westek, Inc.....97	
Shadetree Fabric Shelter.....89	Swedish Marine..... 143	Vallejo Boat Works.....173	Western Grace 178	
Society of Accredited Marine Surveyors/SAMS 181	Swiss Tech America.....44	Vallejo Marina 172	Westwind Precision Details33	
South Beach Harbor.....68	Switlik 156	Vallejo Yacht Club.....87	Whale Point Marine Supply... 135	
South Beach Riggers.....33	System Three Resins 131	Ventura Harbor Boatyard 158	White, Chris Designs..... 217	
South Beach Yacht Club..... 166	Tartan 4400: 'Tartini Time' 223	Vessel Electric 210	Whitehall Rowing & Sail.....93	
So. California Yacht Sales..... 222	The Boatyard at Grand Marina12	Voyager Marine..... 181	Windpath Sailing, Inc.....81	
Spectra Watermakers.....48	Tim's Zodiac Marine.....83	W.D. Schock Corp.83	Wizard Yachts, Ltd. 224	
Spinnaker Sailing S.F.....95	TMM/Tortola Marine Mgmt ... 176	Waypoint 153	Wright Way Designs..... 168	
		Weatherguy.com..... 215		





dewitt

*Latest commission
for
Kathy Forte,
in honor of
John.*

DeWitt Art Gallery & Framing 121 Park Place, Point Richmond, CA 94801

(510) 236-1401 • (800) 758-4291 www.jimdewitt.com

Tuesday-Thursday 10:00 a.m. to 5:00 p.m. • Friday 10:00 a.m. to 3:00 p.m. • Saturday Noon to 5:00 p.m.

STAINLESS STEEL CHAIN

Custom lengths
in link sizes from 5/32" to 1"
in Proof Coil and BBB Chain

*Strength, Quality
and Dependability...
plus a Lifetime Warranty!*

**Stainless Steel Marine Hardware,
Rigging & Fittings at Reasonable Prices.**

See our complete catalog and order on the Web:

www.BOSUNSUPPLIES.COM

Or call toll-free for catalog and to order



(888) 433-3484

Marine Diesel Specialists AT YOUR SLIP!



30 years experience • Universal/Westerbeke dealers
Repairs/Tune-ups all models • Engine Surveys, Instruction

BAY MARINE DIESEL

510-435-8870

baymarinediesel@comcast.net

Save Your Aft!

Using one of our 1400+ patterns or your own pattern, let our craftsmen create a comfortable, durable, and stylish set of all-weather cushions for your cockpit. Find your custom, closed cell foam cushions at www.bottomsiders.com!

BottomSiders



BottomSiders
2305 Bay Avenue
Hoquiam, WA 98550

Call Toll Free: (800) 438-0633
cushions@bottomsiders.com
Fax: 360-533-4474

GEAR UP TO WIN!

CUSTOM EMBROIDERED SAILING GEAR



JACKETS • SHIRTS • CAPS



EMBROIDERY FACTORY
Benicia, California • 707.746.7625
www.embroideryfactory.com



Bay Island YACHTS

(510) 814-0400

yachtsales@bayislandyachts.com
www.bayislandyachts.com

34' CATALINA, 1989



Just listed and at our dock.
\$46,900

37' TAYANA



Just listed. At our dock.
\$69,500

WAUQUIEZ HOOD 38



1979. Great cruiser.
\$77,500

35' SCHOCK, 1994



Performance cruising.
\$45,500

36' SOLARIS SUNSTAR



New price. Recent survey.
\$98,500

YOUR MULTIHULL BROKERAGE SPECIALIST

82' CNB.....	\$1,700,000
56' MARQUISES, 1997.....	€390,000
50' TROPIC, 1993.....	€253,000
48' PRIVILEGE, 1991.....	\$400,000
48' PRIVILEGE, 1990.....	\$400,000
44' KOHLER, 1993.....	\$249,000
43' BEUZE, 2003.....	\$416,000
43' LAGOON POWER CAT, 2003.....	\$550,000
42' VENEZIA, 1995.....	\$195,000
38' ATHENA, 1998.....	\$185,000
33' SEAWIND, 2000.....	\$182,000
POWER CATS	
40' EUPHORIE, 1991.....	€145,000
37' MARYLAND, 2002.....	315,000

40' HUNTER, 1985



At our dock.
Reduced to \$59,500

NORTHSTAR 40, 1973



Affordable center cockpit cruiser.
\$39,500

ISLANDER BAHAMA 30



Perfect family Boat boat.
\$22,500

MORE LISTINGS

39' COLUMBIA.....	\$39,950
36' CATALINA.....	\$45,000

HIGH VISIBILITY SALES BASIN SPACE
AVAILABLE FOR QUALITY LISTING



YACHTWORLD.com

In Grand Marina • 2099 Grand St., Alameda, CA 94501
Fax (510) 814-8765

PRODUCT DESIGN
FOR THE MARINE AND
WATER SPORTS INDUSTRIES
**MECHANICAL & ELECTRICAL
ENGINEERING**





DESIGNS

E-M DESIGNS
171 Ocean Blvd.
Box 97
Half Moon Bay
CA 94019-0097
650-728-3406
www.emdesigns.com

VOLVO PENTA

ENGINES • PARTS • SERVICE

We Ship Anywhere

1-800-326-5135

(415) 453-1001
FAX: (415) 453-8460
www.helmutsmarine.com
619 Canal Street
San Rafael, CA 94901



MARINE SERVICE INC
AUTHORIZED POWER CENTER

Donate your Boat

Cars, Trucks, RVs, & Real Estate
We handle all DMV & Smog
Running or Not (restrictions apply) Tax Deduction



BLUEWATER NETWORK | 800-324-7432

"Proceeds help Bluewater Network reduce greenhouse gases, clean up our air and water, and protect marine mammals and wildlife."

Berkeley-Brisbane Boat Sales +



42' CARVER M-YACHT, 1987, H-Cabin
Gas twin, no sales tax! \$139,000

55' KAYOT PANTOON H-Boat, '76, like new...\$99,000
51' Bill GARDEN DESIGN ketch, '77.....\$99,000
41' MAINSHIP, '89, flybridge.....\$99,000
34' SEARAY bridge, '87, low hours.....coming soon
27' CAL JENSEN, '73, pop-up top, in Berkeley.....
.....5k - yes, 5k

NEW

Sales Slips
As low as \$120/mo!!

For qualified listings
at only
\$10/ft of Beam!!

Now Brisbane and
Berkeley Boat Sales
cell (415) 515-9215
www.berkeleyboatsales.com



Offices Independently Owned

**Call For Free Report –
“24 Essential Tips To Buying Your Next Boat”**

Cruising World Pacific, Inc.

1853 Embarcadero, 2nd Floor, Oakland, CA 94606

(510) 764-1734

5060 N. Harbor Dr., Suite 165, San Diego, CA 92106

www.yachtworld.com/cruisingworldpacific



DESCRIPTION		24/7 ext.	DESCRIPTION		24/7 ext.
70' Andrews	1998	\$339,000	5223	36' Catalina MkII	2000 \$114,900 7133
52' Tayana CC Cutter	1991	\$295,000	7253	36' Catalina MkII	1999 \$113,900 7143
50' Hudson Force 50 Ketch	1974	\$109,900	7013	36' Catalina sloop	1984 \$55,000 7153
48' Liberty 458	1983	\$175,000	5173	36' Columbia sloop	1968 \$29,900 7163
47' Beneteau 47.7	2001	\$330,000	7023	34' Cal Pearson	1976 \$29,500 7173
44' Peterson cutter	1978	\$114,000	7033	34' Pacific Seacraft	1989 \$119,900 7193
41' Hunter 410	2004	\$224,900	7043	33' NorWest 33.5	1982 \$39,500 7203
40' Jeanneau DS	1998	SOLD	3103	32' Capital Gulf	1985 \$49,995 7213
38' Baltic Doug Peterson	1984	\$128,000	7083	32' Fuji cutter	1977 \$49,900 7223
37' Endeavour sloop	1978	\$55,000	7123	31' Prout Cat	1983 \$79,000 5123

**You can receive a boat info sheet via our 24/7 Auto Fax Back
Call (888) 827-1891 then dial extension**

52' TAYANA CC CUTTER, 1991

\$295,000
Auto Fax Back
(888) 827-1891
ext. 7253



Call for information on
**YACHT CHARTER
PLACEMENT**
on San Francisco Bay
(510) 764-1734

PROUT 31, 1983

Yanmar diesel.
Two stateroom.
Auto Fax Back
(888) 827-1891
ext. 5123



BlueBoater Tip of the Month:

Check your seacocks. Open and close all of them this month. If frozen, time to service/replace.

APA latest News: We expand our program into the Delta. We now monitor for illegal pollution in the Monterey Bay National Marine Sanctuary, San Francisco Bay, and the Delta.

Our Sponsors:

Boat on the Bottom?
Call SaltyDingo
Marine Salvage
888-416-7174



PrePurchase, Insurance,
and Damage Surveys on
Vessels with offices in
Berkeley, Santa Cruz,
Sacramento, and the Delta
888-524-4113



DONATE YOUR BOAT

to the Aquatic Protection Agency. We protect our precious coastal waters from illegal toxic pollution. We can use your equipment, so you will get maximum value for your donation.



We are on the water, monitoring cruise ships, performing BlueBoater trainings, and testing outfalls for harmful toxins.

Call 415-235-0756
boats@aquaticprotection.org
www.AquaticProtection.org

HERITAGE

Yacht Sales

Live your Dreams



47' Passport AC
2002
\$449,500



32' Ericson 200
1989
\$47,500



37' Pacific Seacraft
Yawl, 1984
\$105,500



38' Alerion Express
2008



33' Alerion Express
2008



28' Alerion Express
2008



Your SoCal Alerion Dealer

Long Beach-Naples	231 North Marina Dr. 866-56-YACHT
Newport Beach	829 Harbor Island Dr. 877-38-YACHT
Wilmington	Berth 202 Peninsula Rd. 877-59-YACHT

Full specs at www.heritageyachts.com

Southern California Yacht Sales



THE LOST SOUL ~ 56' Formosa, 1981

Legendary World Cruiser Available for \$475,000

After a recent 300k refit, *The Lost Soul* is back on the high seas and for sale to the next adventurer.

Live the dream!

Contact listing agent Greg Kovsky at (714) 222-8890

Find details of
this great yacht
and others at...



Kensington Yachts

"Everyone needs a bigger boat"

UNIQUE, REDUCED COMMISSIONS!

Our commission structure is on a sliding scale.

- Have a large note?
- Two boat owner?
- Death or family emergency?
- Want to trade up?

We have seen every situation, and understand.

Call us today. Let us help you sell your boat!



30' BABA, 1982...\$57,900



53' SPENCER, 1973...\$219,000



36' ALBIN CLASSIC, 1980...\$58,900



38' CATALINA, 1983...\$44,900

SAIL	POWER - con'd
30' CATALINA, 1980..... \$18,900	41' MAXUM 4100 SCA, 2000..... \$234,000
30' BABA, 1983..... \$68,500	38' PACEMAKER, 1973..... \$37,000
POWER	25' MONTEREY 250, 2005..... \$59,000
45' CALIFORNIAN MY, 1989..... \$235,000	

Kensington Yacht & Ship Brokers

email: yachts@kensingtonyachts.com

877.444.5272 • 415.793.9376

www.kensingtonyachts.com

2004 TARTAN 4400: TARTINI TIME

\$495,000



- Hull #1 of of Tartan's newest Deck Salon
- Electric winches • Vacuflush heads
- Full batten main, roller genoa, cruising spinnaker
- Espar central heat • Bow thruster
- Kato davits with Caribe inflatable
- Only 140 hours on diesel engine

*Boat is loaded with options and in new condition.
Call for details and other photos.*

(530) 318-0730

amjohn@sbcglobal.net

NEW ERA yachts

POWER & SAIL

41' MORGAN OUT ISLAND BRONCO 1982

Start cruising now!
This very well equipped seven-time vet of the Baja Ha-Ha has won class and 'soul sailor' every year but one as the boat which has sailed the entire course from San Diego to Cabo. It's a treat to find a boat this comfortable that sails so well. She's ready for you to take her on her eighth. Sailaway for \$99,500

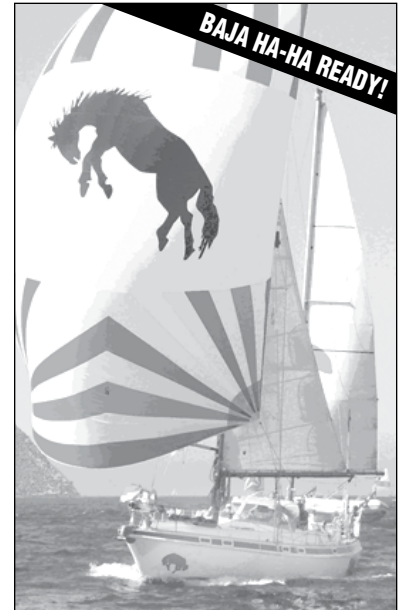

51' BENETEAU, 1986 • \$159,000



47' VAGABOND, 1981 • \$165,000



43' HANS CHRISTIAN, 1979 • \$139,000



37' BENETEAU 373, 2006 • \$149,000



38' HANS CHRISTIAN, 1985 • \$119,500



36' CHEOY LEE, 1986 • \$59,000



36' ISLANDER, 1978 • \$39,900



33' NEWPORT, 1984 • \$25,000



31' HUNTER 310, 1999 • \$59,900



29' CAL, 1976 • \$17,000

35' Morgan.....	SOLD	31' Hunter.....	SOLD
32' Hunter Vision.....	SOLD	30' Hunter, 1987.....	\$28,500
31' Hunter.....	\$28,500	30' Hunter, 1979.....	\$17,000

2021 Alaska Packer Place, Alameda, CA 94501
sales@newerayachts.com

(510) 523-5988

www.newerayachts.com

CHARLOTTE SCHMIDT

YACHT SALES

4100A Harbor Blvd.
Oxnard, CA 93035
Fax (805) 382-2374

When Experience Counts
In SF Bay Area: (415) 613-0712

(805) 382-2375

Csyachtsales@cs.com

www.yachtworld.com/charlotteschmidt



51' CHB PILOTHOUSE LRC, 1978 Twin Ford Lehmans, full flybridge, dual steering, 2 staterooms, washer/dryer, pilothouse with dinette & berth, strong offshore cruiser, rare offering, great price. Call Listing Agent Gary (415) 613-0712.



37' TAYANA CUTTER, 1981
Robert Perry design. 40 hp Yanmar dsl, Raymarine chart plotter/radar, autopilot, SSB, dodger bimini. Many upgrades past two years. Ready to cruise!
Asking \$110,000



42' CATALINA MK II, 1996
Yanmar diesel, inverter, radar, autopilot, GPS, davits/dinghy, dodger, three staterooms. Excellent condition.
Asking \$144,000



32' NAICAT PILOTHOUSE MTL, 1996
Yanmar diesel, radar, GPS, inverter, refr., air/heat.
Stout offshore cruiser.
Asking \$150,000



47' VAGABOND KETCH, 1986 Ford Lehman dsl, genset, chart plotter, radar '06, AP '06, SSB, 12' Avon, dodger. Stunning/Top condition. Won't find a better Vagabond. At our docks. Asking \$239,000



44' KELLY PETERSON C/C, 1978 Westerbeke 60 hp dsl, radar, autopilot, chart plotter, dodger, Avon dinghy, 6 hp OB, modified full keel. Clean and accommodating for world cruising! Asking \$99,000

Randall Burg YACHT AND SHIP, INC.

Representing over \$38 Million in Pre-Owned Inventory!

Marina del Rey
Newport Beach
San Diego
Alameda
info@rbyachts.com • www.rbyachts.com

(310) 574-9449
(949) 675-5940
(619) 222-1907
(510) 865-1934



78' CUSTOM GAFF SCHOONER, 1971 Stunning. Asking \$595,000



70' CUSTOM NEW ZEALAND MOTORSAILER, 1991, \$450,000



51' MASON, 1958 Restored quality classic. \$87,900



45' STARRATT CENTER COCKPIT KETCH, 1989 Great value. \$85,000



44' NORSEMAN, 1983 Performance bluewater cruiser. \$228,000



39' CROWTHER SPINDRIFT CATAMARAN, 1980 Solidly built. \$44,500



38' LAGOON CAT, 2001 Pristine West Coast multihull. \$309,000



37' RAFIKI CUTTER, 1978 Heavy-duty ocean-crossing cutter. \$58,000



31' PACIFIC SEACRAFT, 1979 Quality full keel double-ender \$69,000



30' WILLARD, 1976 Well-preserved, lightly used cruiser. \$47,900



48' DEFEVER, 1980 Elegant & impressive. \$185,000



42' GRAND BANKS, 1974 Well-maintained classic. \$139,500

QUALITY LISTINGS NEEDED • OPENINGS FOR SALESPERSONS IN THE ALAMEDA AND SAN DIEGO OFFICES

OUR DAILY BOAT SHOW!



54' SKALLARUD, 1961
A world cruiser awaiting completion.
Built in California. \$49,000



44' C&C, 1986
This fast cruiser/racer will handle
tough conditions. \$150,000

SAIL

60'	THURSDAY'S CHILD, '83	\$99,000
54'	SKALLARUD, '61	49,000
50'	HUDSON FORCE 50, '81	149,000
50'	HOLLMAN 50, '89	229,000
45'	EXPLORER, '79	125,000
44'	C&C, '86	150,000
41'	AMEL, '80	70,000
40'	FARR, '84	60,000
40'	OLSON, '82	59,500
40'	OLSON, '83	85,000
40'	FAST, '80	15,000
37'	HUNTER, '93	85,000
37'	RANGER, '74	29,000
35'	ERICSON, '72	21,000
34'	PETERSON OOD, '79	32,500
34'	GEMINI, '96	105,000
33'	11 METRE, '90	18,000
32'	COLUMBIA SABRE, '66	6,000
30'	TARTAN, '78	19,500
30'	OLSON, '79	10,000
30'	SANTANA, '79	19,400
30'	CARTER, '76	19,000

30'	CAPRI	12,000
28'	ALBIN SLOOP, '82	13,000
28'	WYLIE HAWKFARM, '78	6,000
27'	CAPE DORY	15,000
27'	CATALINA, '79	8,000
26'	COLUMBIA, '72	3,000
22'	MARSHALL CATBOAT, '96	35,000
17'	HUNTER 170	7,689
14.5'	HUNTER 146	4,500
14'	HUNTER 140	4,224
9'	HUNTER XCITE	2,200

POWER

35'	LARC, '63	90,000
34'	MAINSHIP, '80	49,500
32'	UNIFLITE, '76	24,400
32'	CARVER, '87	30,000
32'	BOUNTY	185,000
32'	BAYLINER, '90	45,000
28'	BAYLINER 2885, '92	32,000
23'	WHALER, '01	69,950
19'	REINELL, '77	3,500
17'	CHRIS CRAFT, '59	19,000
9'	CARIBE INFLATABLE, '91	2,500

NELSON
Yachts
Carl Nelson
Chad Freitas, Broker

(877) 517-8281
sales@nelsonyachts.net

www.nelsonyachts.net

GO FASTER Wizard YACHTS LTD.

Bill Lee
Dan O'Brien
Tom Carter



345 Lake Ave., Suite G
Santa Cruz, CA 95062
(831) 476-9639 fax (831) 476-0141
www.fastisfun.com



79' SPARKMAN & STEPHENS PROPER RACER/CRUISER. *Kialoa III* is the last of a generation. Very nice, complete int. \$495,000



SANTA CRUZ 50. Go fast and have fun. Recent mast, sails and scoop. 50% partnership available \$89,500



HOBIE 33. Deep draft, points super, many short handed features. Trailer. Best buy pocket racer!! \$19,900



COLUMBIA 50. Club race or cruise, this is one of Bill Tripp Sr.'s best designs. Survey and one-year Santa Cruz slip available. \$64,000



SANTA CRUZ 50. New paint, updated sails, major upgrades, water ballast, sprit, excellent short handed boat. \$157,000



CATANA 411 CATAMARAN. Twin diesels, four staterooms, daggerboards for good upwind performance. Lying Ecuador. \$199,000



Marotta Yachts of Sausalito

Brokers of Fine Sail and Motor Yachts

415-331-6200 • info@marottayachts.com



See at:
www.marottayachts.com

45' ISLAND PACKET, 1998

In very nice shape and well equipped for cruising: three recent Quantum sails, new storm trysail and spinnaker, Hydovane autopilot and internal B&G 12V autopilot, Fisher Panda 4kw genset, Switlik six-person liferaft, Icom SSB, and more. Just hauled and detailed and shows very well. Lying New Zealand.

\$265,000



See at:
www.marottayachts.com

47' JEANNEAU SUN ODYSSEY, 1992

Sexy Euro-style performance cruiser with deep draft Kevlar-reinforced hull and nicely laid out, spacious 3-stateroom interior. Well equipped with offshore dodger, full suite of electronics, new Doyle sails, heavy duty ground tackle and 10-ft Caribe RIB on nicely executed stainless steel davit system.

\$199,000



See at:
www.marottayachts.com

46' BENETEAU OCEANIS 461, 2000

Bristol two stateroom/two head 461 never cruised or chartered. Custom Awlgripp'd dark blue hull plus upgraded 76hp Yanmar diesel, furling jib and main, heavy duty custom hardtop dodger and full Raytheon electronics, much more.

Transferable Sausalito Yacht Harbor slip.

\$199,000



See at:
www.marottayachts.com

39' GRAND SOLEIL, 1986

Over \$300,000 (this is not a typo!) spent upgrading this Swan look-alike over the past few years: new Yanmar engine with less than 200 hours, sails, rigging, winches, dodger, electronics, interior all redone, much more. Transferable Sausalito slip.

\$109,000



See at:
www.marottayachts.com

39' COLUMBIA CENTER COCKPIT, 1979

This yacht had more than \$30,000 spent since 2002 and now shows better than new: rebuilt engine, new mainsails, renewed rigging, replumbed, rewired, replaced original plastic portholes with ABL stainless steel, new custom hard dodger, etc.

\$79,000



See at:
www.marottayachts.com

34' SUNSET SLOOP, 1967

This full keeled little jewel was designed as the ultimate Bay daysailer and built like a piano by Al Silva shortly after he left the legendary Stone Boat Yard. Fully restored, she's one of the finest boats of this era we've ever seen, everything's done to showboat standards.

\$69,500



See at:
www.marottayachts.com

36' ISLANDER FREEPORT, 1978

Rare B plan interior with Pullman double berth! Note raised cabin top, deep comfortable cockpit with step-thru transom, keel stepped mast, skeg hung rudder and wide decks with anchor well – all were very innovative back in the late 1970s. Very nice shape and only one on West Coast.

\$49,900



See at:
www.marottayachts.com

37' WAUQUIEZ CHANCE, 1971

The Chance 37 is a classic performance cruiser, and unfortunately rare in the U.S. Which is a shame because with a draft of 6', the boat's a blast to sail on the Bay. This particular example is very nice inside and out, is competitively priced and lying in a transferable Sausalito Yacht Harbor slip.

\$39,000



See at:
www.marottayachts.com

35' PEARSON, 1985

Built in the U.S. (back east in Rhode Island) to typical high Pearson standards, this is one of the last 35s to be built. She's been a local boat since 1993 and is in very nice shape (just detailed, and the brightwork is bristol), priced right and lying in the Sausalito Yacht Harbor – all in all, a nice turn key package!

\$34,800

100 BAY STREET • SAUSALITO • CALIFORNIA 94965

3 HANS CHRISTIANS



43' HANS CHRISTIAN, 1989
Cutter, Telstar, low hours. \$215,000
Also: 38', 1980...\$99,000
33', 1986...\$112,000

Anchorage Brokers & Consultants YACHTS



www.yachtworld.com/anchoragebrokers
#1 Gate 5 Road, Sausalito, CA 94965

(415) 332-7245
yachts@abcyachts.net

25 Third Street,
San Rafael, CA 94901
(415) 457-9772

CLAY & TERESA PRESCOTT • GEORGE HIGBIE • PHIL HOWE • LARRY MAYNE • DANA PAUL • ARNIE GALLEGOS • PETER BOHN • ED L'ABARRE • JOHN SAUL



PASSPORT 40, 1986
New main, new hull, Awlgrip, Pullman.
Super clean. \$183,900



COUNTESS 44
Ketch rig, Alden design, raised salon, numerous
upgrades. Pristine. \$120,000



3 STEEL
Pictured: 36' SWAIN, 1997...\$98,000
Also: 43' CORTEN, 1984...\$99,000
39' MOTA HUTA, '80...\$29,000



51' ALEUTIAN, 1980
Cutter, center cockpit, great passagemaker and
great price. \$159,900



32' WESTSAIL, 1977
Passagemaker in great shape.
\$52,500

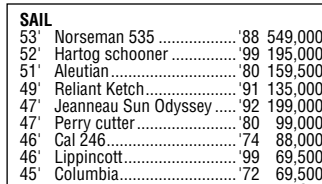

35' BABA, 1979
Perry design, new dodger, dinghy davits, clean.
\$69,500



37' C&C, 1982
All updated UK sail inventory w/spinnakers,
electronic package, cruiser/racer. \$64,900

SAIL	
53' Norseman 535	88 549,000
52' Hartog schooner	99 195,000
51' Aleutian	80 159,500
49' Reliant Ketch	91 135,000
47' Jeanneau Sun Odyssey	92 199,000
47' Perry cutter	80 99,000
46' Cal 246	74 88,000
46' Lippincott	99 69,500
45' Columbia	72 69,500
44' Nordic	82 Call
44' Hylas	86 165,000
44' Norseman CC	84 225,000
44' Islander Schooner	80 85,000
43' Corten steel SS	84/'08 99,000
43' Hans Christian	89 215,000
42' Baltic DP	84 189,000
41' Beneteau 411	99 99,000
41' CT	76 79,000
40' Passport Pullman	86 183,900
40' Cheoy Lee MS	75 73,900
40' O'Day	86 75,000
40' Hunter 40.5	95 112,000
40' Challenger	73 67,500
40' Catalina 400 Mk II	04 205,000
39' Cal	78 69,000
39' Mota Huta, steel	80 29,000
38' Morgan	78 44,000
38' Ingrid	76 & '84 from 61,900
38' Hans Christian	80 99,000
37' Alberg, equipped	72 70,000
37' Rafiki, new engine '07	77 57,000
37' Irwin	79 35,000
36' Islander	77 50,000
36' Catalina	'84 & '93 from 52,500
36' Sweden	84 69,000
36' Palmer Johnson	74 46,000
36' Swain Steel	97 98,000
35' Hanse	08 Inquire
35' Hunter 35.5	93 54,750
35' Baba	79 69,500
35' Ericson Mk III	84 48,500
35' Fantasia Mk II	79 50,000
34' C&C, nice	80 37,500
34' Sabre	83 46,000
34' J/105	01 125,000
34' Chinook	72 20,000
33' Hans Christian	86 112,000
32' Targa, center cockpit	78 34,500
32' Westsail	77 52,500
32' Odyssey, nice	67 75,000
31' Pacific Seacraft Mariah	79 69,000
30' Baba	82 57,900
30' Carabella cutter	66 14,900
30' Catalina (two)	'75 & '81 16,500
30' Islander MkII	74 Call
30' Pacemaker, cert	75 15,000
30' Lancer	80 32,500
30' Golden Gate	91 34,500
29' Hunter 29.5	94 33,500
29' J/29	83 25,000
28' Newport	81 9,700
26' Alden	33 11,000

POWER	
85' Broward Alum.	'81 965,000
67' Stephens Alum.	80 795,000
65' Pacemaker, cert	71 299,000
65' Elco Classic MY	26 450,000
65' Chris Craft	65 135,000
53' Hatteras MY, new engines	76 259,000
50' Stephens	63 179,000
50' Stephens	65 135,000
50' Whitcraft	74 118,000
48' Dutch canal barge	50 219,000
45' Chris Craft	73 149,000
44' Marine Trader CP	84 159,000
44' Defever	82 195,000
44' Gulfstar MV	79 147,000
43' Viking Sundeck	77 95,500
41' Hatteras	61 Inquire
41' Hatteras, nice	65 149,000
40' Sea Ray Sundancer, dsl	97 169,000
38' Holiday Mansion	89 38,500
38' Chris Craft	65 66,000
35' Cooper Prowler	86 78,000
34' Atlantic SF	89 79,000
34' Mainship	81 48,000
34' Sea Ray Sundancer, dsl	01 155,000
34' Kevlacat	97 160,000
34' Tolly Craft	72 29,000
32' Bayliner 3288	89 54,900
32' Unifite, t/d	77 37,500
32' Silverton FB, 370 hrs	98 55,500
30' Sea Ray	88 34,500
29' Boston Whaler	99 99,000
29' Monterey	95 29,000
28' Boston Whaler, twin Merc	99 59,000
28' Mako CC	96 32,500
28' Cruiser, nice	86 28,000
27' Seaport w/trailer	96 90,000
26' Osprey long cabin	03 85,000
26' Osprey	02 98,000
26' Chaparral, trailer	94 19,000
24' Orca, inboard	99 39,995
24' Osprey	96 69,500
22' Grady White 222 w/trlr	02 59,000
17' Marlin, '91 w/OB, '02 w/trlr	29,500



47' JEANNEAU SUN ODYSSEY, 1992 3 state-rooms, master is Pullman, upgraded beautiful interior, RF main, 75hp Yanmar. Worth seeing! \$199,000



BENETEAU 411, 1999
Tri-cabin.
\$99,000



35' J/105, 2001
\$125,000



HANSE 470
SEVEN REASONS TO OWN A HANSE: EASE OF USE, SAFE, COMFORT, PERFORMANCE, QUALITY, STRENGTH & PRICE.

Hanse Dealer Report

We had a great time at Clipper Cove last month. Join us next year in your 2009 Hanse! The new models will be displayed at the annual dealers meeting later this month. Come for a test sail this summer!

Larry R. Mayne - Yacht & Ship Broker
Dealer & New Boat Sales Manager
Sales dock slip available, \$300/month



HANSE 350, 2008
Already commissioned.
Ready to go sailing.
Inquire



85' BROWARD, 1981
Aluminum. Mexico to Kodiak, Alaska. Meticulously maintained. Newer engines.
\$965,000

NORPAC YACHTS

1150 Brickyard Cove Rd., B9, Pt. Richmond, CA 94801

(510) 232-7200 • FAX (510) 232-7202

email: info@norpacyachts.com

WE HAVE BUYERS & NEED MORE BOATS!
LIST YOUR BOAT NOW & WE SHALL SELL HER!

**FOR MORE
 SEE OUR
 norpacyachts.com
 WEBSITE**

ESTATE SALE

58' LOD NEW ZEALAND SCHOONER. 16'6" beam, strong, copper riveted, 3x kauri-planked. Detroit dsl, radar, AP, watermaker, genset, shower, 3 S/Rs. World cruiser. GREAT OPPORTUNITY! **Asking \$99,900**

DREAM CHARTER BUSINESS

100' ADVENTURE CHARTER YACHT & BUSINESS in PANAMA. Successful, operating Adventure Tourism business w/ high-endurance, stand-alone luxurious & extremely seaworthy steel vessel. 16 overnite pass., tenders/speedboats, surfing, diving, fish, explore & ALL THE TOYS. **Try \$2,250,000USD**



ENGLISH ELEGANCE

66' THORNYCROFT CUTTER-RIGGED KETCH Classic 1923 design, well maintained. She's like a beautiful & comfortable private British club down below. Must be seen. Teak decks, diesel, genset, radar and more. Extremely charming and a great performer. **Asking \$199,500**



36' PICNIC BOAT. Exceptionally high-quality, comfortable & luxurious performer. Dsl, absolutely loaded with equipment & can't be told from NEW! With Warranty. Already located in Vancouver, BC, Canada, for your cruising pleasure. Motivated seller! **Asking \$324,950**



REDUCED

57' CHINESE JUNK. Teak const. Huge & very comfortable well lit & well appointed inter. Outstanding liveboard cruiser w/ lug rig & highly desirable Gardner dsl. Charm, character. Gen set, washer/dryer. Pos. liveboard slip & more! **\$138,950/Offers**



REDUCED

40' CHEOY LEE GULF 40 PH Sloop 56hp Yanmar dsl, varnished teak hull, copper rivet fastened. Good sail inventory incl, 2 spinnakers, AP, radar, chart/GPS, more! Fresh haulout & ready to go! Washer/dryer ++. **Asking \$39,950**



EXTRA NICE!

36' 52 11 Meter Sloop An excellent vessel from a fine builder. 35hp inboard diesel Saildrive, galley, enclosed head with shower, pulpits and lifelines, well maintained, more! VERY NICE BOAT. **Asking \$47,950**



REDUCED

45' COLUMBIA Center cockpit sloop. Diesel, F/G, roomy, comfortable cruiser with good light and visibility below. Two heads, shower & MORE! These are great cruise/live vessels. We have two, starting at **\$32,500**



HIGH ENDURANCE CRUISING YACHT

75' NORTH SEA TRWLR YACHT. Awesome Bluewater World Cruiser. Massively built in SCOTLAND to go to sea & stay there. CAPE HORN vet. Impeccable total refit & yacht conversion. Fully found & loaded incl. strong, economical & long lasting Gardner dsl main & much more. **Ask \$825,000**



42' SPARKMAN & STEPHENS Slip F/G, dsl engine, spinn., dodger, major refit incl. rig. Beautiful cruiser from world-class architect; she's a very desirable yacht with a great layout, excellent performance & outstanding comfort and cond. Hard to go wrong. **Asking \$49,000**

SAIL
 100' MEGA Slip. Custom offshore performance cruiser. Comfort & luxury with LOTS of room & berths & nearly new. MUST BE SEEN!..... Asking 1,500,000
 51' FORMOSA Ketch. Aft cockpit. Good project. Fiberglass, diesel and lots of extras..... 54,950/Offer
 50' CAULKINS Slip. A project, but all there. Dsl, strip plank, ocean racer..... Try 15,000
 42' SPARKMAN & STEPHENS steel custom cutter by Olin Stephens. Major upgrades. Center cockpit, aft cabin, diesel and more. FULL REFIT NEARLY COMPLETED: BEAUTIFUL!..... Asking 87,900
 39' FREYA Double-ender, steel, dsl, dink-a-b, new point, solar, furling, radar, AP, cruise equipped & more!..... Asking 57,950
 38' INGRID Ketch by Wm. Atkins. Great glass double-ended cruiser. Diesel, vane, furling, radar, EXTRA STOUT! Much recent upgrading. Let's go cruising!..... Asking 60,950
 37' GULFSTAR center cockpit, aft cabin, dodger, diesel & more..... 43,950
 37' VILLENAVE Cruising Cn Blue Water Euro Performance. Loaded..... Asking 43,950
 36' STEEL HARTOG ketch, double-ended cruiser. Great potential, reduced to 9,900
 36' NIELSEN classic 1918 Danish aux. sloop. Nice condition..... Asking 15,000
 35' CHEOY LEE by Robb. Dsl, teak...17,950
 35' MARINER ketch. 2 full sets of sails (one brand new), 4-107 dsl, much recent work. A medium "project boat", Wm. Gardner design. GREAT BUY!..... Try 5,500
 29' PEARSON TRITON. New diesel. Total refit nearly done..... Asking 15,950
 28' MORGAN Out Island sloop, 1/B, shower and more! A Great Boat at a Great Price!..... Asking 8,500
 27' BALBOA Sloop. Diesel auxiliary, wheel, standing headroom, 2-axle E2-Loader trailer..... Asking 12,750
 25' CHEOY LEE FRISCO FLYER, teak..8,000
 23' HERRESHOFF Classic PRUDENCE Sloop with 2003 Honda..... 7,500

POWER
 130' CAMCRAFT Passenger Ship. Certified for 33 passengers overnight. Booked for the season. Virtual turnkey: Money and opportunity..... 2,200,000
 65' STEEL YTM TUG. Beautiful condition. Work her or excellent broad-shouldered yacht conversion. 510 hp Cat gensets ++ more!..... Asking 65,000
 65' CLASSIC MOTORYACHT by WHEELER, 1931. Much recent major struct. rebuild, twins, 3 doubles, crew's qtrs & huge salon. Excellent restoration project...BARGAIN: 49,950/Offers
 60' MATTHEWS MY, '65, twin diesels, big, comfortable liveboard cruiser with South SF berth..... Asking 215,000

45' STEPHENS 1929 classic. Beautiful Gatsby-era motoryacht waiting to transport you back to the days of yachting in the grand style..... Try 75,000
 43' MATTHEWS, '65, diesel. A gem! Loaded and beautiful..... Asking 69,450
 42' GRAND BANKS Tvl. Aft cabin, F/B, Onan, twin dsls, radar. Excellent..... 121,000
 41' CHRIS CRAFT CONSTELLATION. Aft cabin. Great liveboard, full Delta canvas, new shafts, smooth running, dinghy w/ outboard & MORE! Great potential! GREAT LIVEBOARD! REDUCED! Asking 12,950/obo
 37' HATTERAS Convertible. One of their BEST EVER! Maj. refit just complete. Twin 8V53 dsls, 7.5 kw Onan, F/B. Loaded & outstanding..... 179,000/Offer
 37' DEFEVER TRAWLER by North Sea. Dsl, F/G, F/B, 2 heads, showers, radar, gen., thruster, GPS/map & MORE! Very nice...Ask 88,950
 36' UNIFLITE. F/B, aft cabin, twins, radar, GPS and more!..... Asking 59,950
 36' CHRIS CRAFT Express Cruiser, twins, runs well. SUPER BARGAIN!..... Try 3,950/obo
 32' ROBERTS commercial fish w/HERRING PERMIT & more!..... Asking 58,950

32' CARVER. Glass, twins, Sausalito liveboard berth. Nice!..... Asking 30,950
 32' BOWPICKER, aluminum. Commercial (herring) license..... 49,000
 31' MONTEREY BAY EXPRESS PILOTHOUSE utility, F/G, '9a1, twin 130 Yanmars, trailer, USCG- documented, commercial quality gen. REDUCED! Asking 29,950
 30' WILLARD Voyager Trawler/Mh Sail. 4-108 dsl, heat & more! Very colorful... Try 23,950
 30' RINKER 300 EXPRESS. Just refit & repowered very nicely. Twins, aft stateroom + MORE!..... Ask 29,950
 29' WELLCRAFT 2900 EXPRESS. Twin screw (not outdrives). Super clean & nice! Bright red..... REDUCED! Asking 19,950
 27' FARALLON Pilothouse, '86. F/G, twin 5L V8s, fast and seaworthy. Just detailed and very nice..... Asking 51,950
 26' PACEMAKER, cabin cruise /V8, nice!...8,500
 26' BARTENDER by Caulkins. Capable double-ender, V-8. REDUCED..... 7,950
 24' WILSON w/tr. Twin Volvo 6 cyl. dsls, fwd cabin, encl. PH, radar, depth, Loran. Ideal commercial quality fishing/diving boat w/new point & running great! MORE!..41,950/offer

BOAT INSURANCE
 CONTACT OUR EXPERT
ELDENE FLETCHER AT
 eldene@norpacyachts.com
(415) 235-5247



31' PACIFIC SEACRAFT "Mariah" Cutter. Strong FG Double-Ended World Cruiser by Crealock. Dsl, wheel, furling, dodger, RADAR & more! An outstanding vessel for everything from Bay sailing to Blue Water cruising. **Ask \$68,950**



130' CAMCRAFT PASSENGER SHIP USCG inspected & certified for 33 overnight guests in 17 stms, SOLAS, low hrs 3508 CATs, 2,000 gph watermaker, MSD & gray water treatment. Inverter banks for silent eyes, 8 days min. endurance w/o provisioning. Lying Pac NW. **Ask 2,200,000**



58' ALDEN BOOTHBAY MOTORSAILER center cockpit ketch. Dsl, genset, air/heat, new upholstery, much recent refitting & refinishing. Loaded w/ cruising gear, AP, radar ++. Great comfortable bluewater cruiser w/excellent layout & more!! **\$268,950 Ask**



32' FUJI KETCH
 Diesel, furling, shower, full galley, full cruising keel with cutaway forefoot. Very nicely maintained ++. We have two starting at **\$31,950 Asking**



REDUCED GRAND BANKS

32' GRAND BANKS CLASSIC TRAWLER, 1970 Economical diesel, dual helms, flybridge, TEAK decks, full electronics, swim platform, mast and boom. She's a great cruiser and a very well loved design. **\$29,450/Ask**

**CALL (510) 232-7200 OR FREE (877) 444-5087
 OR CALL GLENN DIRECT AT (415) 637-1181
 FOR INFORMATION & INSPECTION APPOINTMENTS**

EVERY JOB IS IMPORTANT!

Call about our
'Well Cared for
Special'*

Having the 125x60-ft *Cheyenne* (background) hauled out at Nelson's is a privilege, but we are just as excited to restore the 14-ft wooden runabout in the foreground. Nelson's treats all jobs and all boats with the same level of enthusiasm – LPU paint on *Cheyenne* and the restoration of a 14-ft classic are both opportunities for the Nelson's team.

***WELL CARED FOR SPECIAL! \$33/FT CALL FOR DETAILS**



23' BOSTON WHALER CONQUEST, 2001
Twin 2006 Mercury 150 hp Verados. Alameda slip, hydrohoist. \$130k+ invested. **\$69,900**



HOLLMAN 50
A turnkey cruiser with luxurious features and an open feel. Lots of space and comfort. **\$229,000**



41' AMEL SHARKI, 1980
Outstanding reputation for safety and comfort in blue water. Asking **\$70,000**



SACRAMENTO AFFILIATE: McClellan Indoor Boat & RV Storage
(916) 640-0141 • www.mcclellanstorage.com



NELSON
Yachts

Chad Freitas, Broker • (877) 517-8281
See ad page 224

Sacramento
Yacht Sales
NOW
OPEN!

Nelson's Marine

www.nelsonsmarine.com
1500 FERRY POINT
ALAMEDA, CA 94501
(510) 814-1858 • FAX (510) 769-0815