

# Latitude 38

VOLUME 367 January 2008

WE GO WHERE THE WIND BLOWS

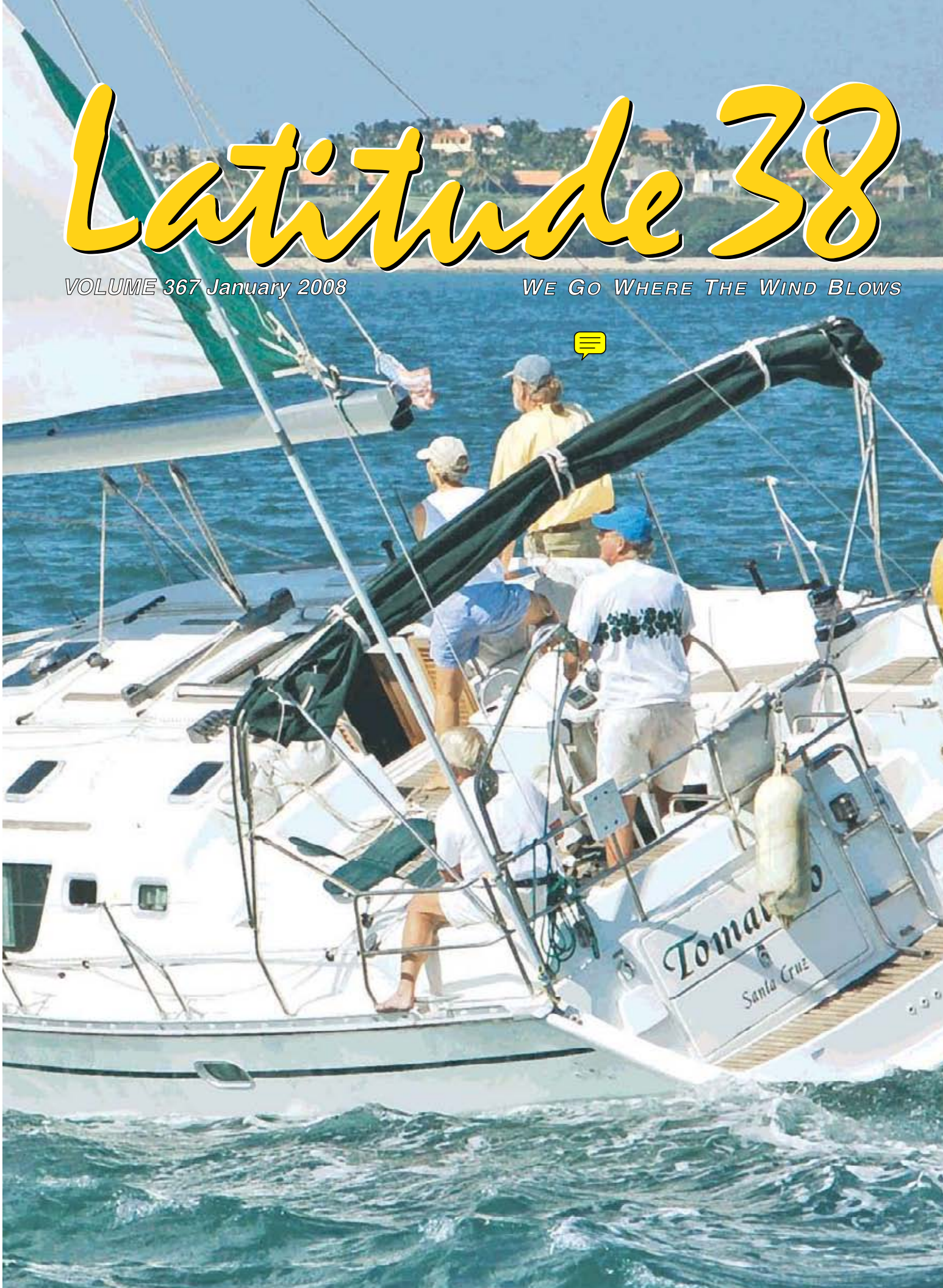

Latitude 38

JANUARY 2008

VOLUME 367





## *It's just that simple.*

With so many marinas to choose from, looking for a slip in the Bay Area can be a hassle. Everyone's looking for the same thing: convenience, a great marina where everything you need is at your finger tips. Never be overcharged for services that should be included in your monthly bill. Grand Marina has great services at a great price. Period.

- Over 400 concrete berths 30 to 60 feet
- Secured Gatehouses (electronic key system)
- Dockside Electrical (up to 50A - 220V)
- Cable TV & Telephone Service
- Heated & tiled restrooms with individual showers
- Beautifully Landscaped
- Ample Parking available
- Sailboat & Powerboat Brokers on site
- Excellent customer service
- Monthly informative newsletter

### DIRECTORY of GRAND MARINA TENANTS

Bay Island Yachts .....	7
Bay Marine Diesel.....	218
The Boat Yard at Grand Marina..	16
Lee Sails .....	212
New Era Yachts.....	224
Pacific Coast Canvas.....	95
Pacific Yacht Imports .....	9

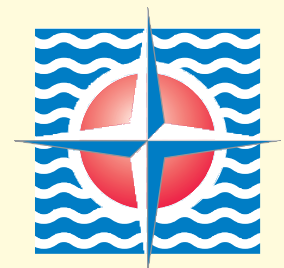

**GRAND MARINA**

ANDERSON-ENCINAL

**510-865-1200**

Leasing Office Open Daily  
2099 Grand Street, Alameda, CA 94501  
[www.grandmarina.com](http://www.grandmarina.com)

*Our wait list for liveaboard status is now closed.*



# Play Your Cards Right!



Last season brought successes in spades to Pineapple powered boats. Racers and cruisers alike found that dealing with Pineapple Sails brings results: sails that perform and endure.

This season offers new opportunities for mastering the many techniques of sailing. New Pineapple sails and the advice and service that go with them stack the deck in your favor.

Don't gamble. Give us a call today.

YOUR DEALER FOR: Musto foul weather gear, Dubarry footwear and Headfoil 2

Sails in need of repair may be dropped off at:  
West Marine in Oakland, Alameda, or Richmond;  
or Svendsen's in Alameda.



## PINEAPPLE SAILS

Phone (510) 522-2200

Fax (510) 522-7700

[www.pineapplesails.com](http://www.pineapplesails.com)

2526 Blanding Ave., Alameda, California 94501

\*Powered by Pineapples



# 28 Reasons to Start Your Year at Passage Yachts

## BENETEAU

31 ~ 343 ~ 37 ~ 40 ~ 43 ~ 46 ~ 49 ~ 523 ~ 57  
10R ~ 44.7 ~ 45 ~ 50



BENETEAU 49



BENETEAU 46



BENETEAU 40



BENETEAU 37

## ISLAND PACKET

37 ~ 41 CRUISER ~ 440 ~ 465 ~ 485



ISLAND PACKET SP 41



ISLAND PACKET 465



ISLAND PACKET 440

## WAUQUIEZ

CENTURION  
40 ~ 45  
PILOT SALOON  
41 ~ 47 ~ 55



WAUQUIEZ PILOT SALOON 41



WAUQUIEZ PILOT SALOON 55

Call for  
great boat show  
deals and free  
equipment  
packages thru  
February 2

## ALERION EXPRESS

20 ~ 28 ~ 33 ~ 38



ALERION EXPRESS 33



## Visit our Alameda Brokerage and Performance Boat Annex at Marina Village

**SWIFT  
TRAWLER 42**  
now only  
**\$419,000**



Alameda



**BENETEAU  
FIRST 44.7**  
now only  
**\$279,000**

Alameda

**SEE PAGE 221  
FOR OUR  
COMPLETE  
BROKERAGE  
LIST**



**ISLAND PACKET 380, 2001**  
**\$235,000!**



FIRST 36.7



FIRST 10R



ALERION 28

**Affordable  
and Exciting  
One Design  
and Handicap  
Racing**

**Beneteau  
First**

**10R**

**36.7**

**40.7**

**Alerion 28**

## January Events Calendar

**Sat-Sun, January 12-13**  
**OPEN BOAT WEEKEND**

Alameda Office  
New & Used Boat Display  
11:00 to 5:00

**Call for great  
Boat Show deals!**

**January 19-26**  
**In the Water**  
**New Boat Show**

Pt. Richmond Office  
Disappointed by the limited display  
of sailboats at the boat show? Stop  
by our show for the best selection  
in cruising and racing yachts.

**Saturday, February 2**  
**VIP Sailing Day**

Test sail a new Beneteau,  
Island Packet or Wauquiez.  
Join us on our monthly test sails  
to experience the latest in sailing  
technology and comfort.

*Reservations required – Call for boat schedule*



Pt. Richmond Office  
1220 Brickyard Cove Road  
p: 510-236-2633 f: 510-234-0118  
Alameda Office ▪ Marina Village  
1070 Marina Village Pkwy, Ste 101  
p: 510-864-3000 f: 510-337-0565

[www.passageyachts.com](http://www.passageyachts.com)  
[sales@passageyachts.com](mailto:sales@passageyachts.com)

*Award-winning Sales & Service since 1981*



# PUSSER'S®

*"The single malt of rum™  
and the father of grog"*



**Forbes writes,** "Pusser's is still made in the same way it was at the time of Trafalgar - in wooden pot-stills as opposed to modern industrial column-stills. This results in the most full-flavored rum available anywhere".



**The original Navy Rum and the father of grog** as the rum of the Royal Navy and Royal Marines for more than two centuries.



*Gold Medals, London, 2001  
San Francisco, 2003 & 2005*



**P**usser's isn't for everyone. Some people prefer rums that are almost flavorless when compared to the intensely rich flavor of Pusser's. But if you want a rum that you can enjoy sipping, or still taste through the mix of your favorite cocktail, then Pusser's is for you. Try a Pusser's and Cola sometime and taste the difference.

Pusser's is not always easy to find but your local retailer can order it for you. Or take a look at HOW TO FIND IT on our web site at

[www.pussers.com](http://www.pussers.com)

*Charles Tobias*

Charles Tobias, Chairman

IMPORTED BY SHAW-ROSS INT'L IMPORTERS, MIAMI, FL. PUSSEY'S RUM 42% ALC/VOL.

## CONTENTS

subscriptions	8
calendar	34
letters	42
loose lips	102
sightings	108
cabo catastrophe revisited	128
sausalito yc midwinters	134
soloing <i>sereia</i>	138
north coast cruise	144
banderas bay blast	148
winners, pt. III	154
max ebb: lyin' eyes	160
the racing sheet	166
world of chartering	176
changes in latitudes	186
classy classifieds	206
advertisers' index	215
brokerage	219

Cover: Birthday boy Jim Casey's Santa Cruz and Tahoe-based Jeanneau 43DS *Tomatillo* crosses the Banderas Bay Blast at Punta Mita.

Photo: 'Lectronic Latitude/Richard

Copyright 2008 Latitude 38 Publishing Co., Inc.

*Latitude 38* welcomes editorial contributions in the form of stories, anecdotes, photographs—anything but poems, please; we gotta draw the line somewhere. Articles with the best chance at publication must 1) pertain to a West Coast or universal sailing audience, 2) be accompanied by a variety of pertinent, in-focus digital images (preferable) or color or black and white prints with identification of all boats, situations and people therein; and 3) be legible. These days, we prefer to receive both text and photos electronically, but if you send by mail, anything you want back must be accompanied by a self-addressed, stamped envelope. **Submissions not accompanied by an SASE will not be returned.** We also advise that you not send original photographs or negatives unless we specifically request them; copies will work just fine. Notification time varies with our workload, but generally runs four to six weeks. Please don't contact us before then by phone or mail. Send all submissions to [editorial@latitude38.com](mailto:editorial@latitude38.com), or mail to Latitude 38 editorial department, 15 Locust Ave., Mill Valley, CA 94941. For more specific information, request writers' guidelines from the above address or see [www.latitude38.com/writers.html](http://www.latitude38.com/writers.html).



# Bay Island YACHTS

(510) 814-0400

yachtsales@bayislandyachts.com  
www.bayislandyachts.com

### PACIFIC SEACRAFT 34



PRICE REDUCED

1989. Ready to go cruising!!  
\$99,500

### 48' AMEL MARAMU



NEW LISTING

1979. New engine + much more.  
Fully reconditioned. \$189,000

### ISLANDER BAHAMA 30



NEW LISTING

1979. Fresh from Lake Tahoe.  
\$22,500

### WAUQUIEZ HOOD 38



1979. Truly a performance cruiser.  
\$85,500

### NORTHSTAR 40, 1973



SISTERSHIP

NEW LISTING

Center cockpit cruiser.  
\$53,000

### HUNTER LEGEND 40



NEW LISTING

1989.  
The Legend...\$69,500

### CONTESSA 32



"Old world" quality. Excellent sailing.  
\$39,500

### 36' CATALINA, 1983



PRICE REDUCED

Great condition for her age.  
Good gear. \$45,000

### BABA 30, 1983



NEW LISTING

Nicely kept.  
\$65,500

### 35' SCHOCK, 1994



PRICE REDUCED

Ex-class champion. "Full race."  
\$45,500

### 36' SOLARIS SUNSTAR, 1993



SISTERSHIP

REDUCED!

New Listing at Grand Marina  
\$119,000

### YOUR MULTIHULL BROKERAGE SPECIALIST

#### SAILING CATS

82' CNB.....	\$1,700,000
56' MARQUISES, 1997.....	€390,000
50' TROPIC, 1993.....	€253,000
48' PRIVILEGE, 1991.....	\$400,000
48' PRIVILEGE, 1990.....	\$400,000
44' KOHLER, 1993.....	\$249,000
43' BELIZE, 2003.....	\$416,000

43' LAGOON POWER CAT, 2003	\$550,000
42' VENEZIA, 1995.....	\$195,000
38' ATHENA, 1998.....	\$185,000
33' SEAWIND, 2000.....	\$182,000

#### POWER CATS

40' EUPHORIE, 1991.....	€145,000
37' MARYLAND, 2002.....	315,000

### MONOHULLS FOR SALE IN THE CARIBBEAN

52' NAUTICAT.....	\$390,000
51' BENETEAU 510.....	\$189,000
50' JEANNEAU.....	\$290,000
47' WAUQUIEZ.....	\$219,000
47' JEANNEAU.....	\$155,000
47' BENETEAU.....	\$275,000
47' SWAN.....	\$199,000
43' SAGA.....	\$272,000
43' SLOCUM.....	\$160,000

### NONSUCH 36, 1987



'FAST LUCY'

Lovable, simple, elegant!  
\$102,500

### SOLD

ALEUTIAN 51 BENETEAU 39  
ERICSON 35 (2)  
MORGAN 41 HUNTER 29.5  
ISLANDER 32 CATALINA 34  
BENETEAU 40S  
HUNTER 430 SPINDRIFT 43  
ERICSON 30+ IRWIN 46  
ISLANDER 37 COMPAC 25  
NONSUCH 30 (2)  
HUNTER 29.5 ERICSON 28  
O'DAY 30 HUNTER 45 (2)  
CATALINA 27 PEARSON 32  
BENETEAU 42s7  
FORMOSA 51 HUNTER 33  
BENETEAU 390 CHB 34  
HUNTER 37.5 NEWPORT 33  
HUNTER 40 ISLANDER 30  
HUNTER 37 NEWPORT 30  
CATALINA 36 SANTANA 30  
BENETEAU 47 NONSUCH 33  
MULL 82

### SPINDRIFT 43, 1981



NEW LISTING

Ready for liveaboard cruising.  
\$129,000

### HUNTER 31, 1984



NEW LISTING

...around  
\$30,000

### 32' CUST. GAFF RIGGED



Full keel cruising boat, baggy wrinkle.  
\$55,500



In Grand Marina • 2099 Grand St., Alameda, CA 94501 • Fax (510) 814-8765

YACHTWORLD.com



# BOAT LOANS

from



Trident Funding

*"a fresh approach from  
people you can trust"*

*In Northern California call  
**JOAN BURLEIGH**  
**(800) 690-7770***

*In Southern California call  
**JEFF LONG**  
**MARGE BROOKSHIRE**  
**(888) 883-8634***

*In San Diego  
**MIKE LOCKARD**  
**(619) 255-5666***

www.tridentfunding.com

## SUBSCRIPTIONS

Please read form carefully before submitting.

We regret that we cannot accept foreign subscriptions. Check, money order, or credit card information must accompany request. Please allow 4-6 wks to process changes/additions, plus delivery time.

Enclosed is \$18 for one year on eBook

Check out [www.latitude38.com](http://www.latitude38.com) and click on eBooks to see what we're talking about. Our eBooks are now in PDF format, easy to use with Adobe Reader



Enclosed is \$36 for one year Third Class Postage

(Delivery time 2-3 weeks; Postal Service will not forward third class, so you must make address change with us in writing.)

Enclosed is \$55 for one year First Class Postage (Delivery time 2-3 days; FPO/APO (military), Canada & Mexico subscriptions are first class only)

Third Class Renewal  First Class Renewal (*current subs. only!*)

Gift Subscription – Card to read from: \_\_\_\_\_

Name \_\_\_\_\_

Address \_\_\_\_\_

City \_\_\_\_\_

State \_\_\_\_\_

Zip \_\_\_\_\_

Phone: ( ) \_\_\_\_\_ Email: \_\_\_\_\_

**CREDIT CARD INFORMATION**  
Min. Charge \$20

MASTERCARD

VISA

AMERICAN EXPRESS

Number: \_\_\_\_\_ Exp. Date: \_\_\_\_\_

### INDIVIDUAL ISSUE ORDERS

Current issue = \$6.00 • With classy ad placed = \$5.00

Back Issues = \$7.00 (must indicate exact issue by month or vol. #)

### DISTRIBUTION

We have a marine-oriented business/yacht club in California which will distribute copies of *Latitude 38*. (Please fill out your name and address and mail it to the address below. Distribution will be supplied upon approval.)

Please send me further information for distribution outside California

Business Name \_\_\_\_\_

Type of Business \_\_\_\_\_

Address \_\_\_\_\_

City \_\_\_\_\_

State \_\_\_\_\_

Zip \_\_\_\_\_

County \_\_\_\_\_

Phone Number \_\_\_\_\_

## Latitude 38

*"we go where the wind blows"*

Publisher/Exec. Editor.....Richard Spindler.....richard@latitude38.com.....ext. 111  
Associate Publisher.....John Arndt.....john@latitude38.com.....ext. 108  
Managing Editor.....John Riise.....johnr@latitude38.com.....ext. 110  
Senior Editor.....Andy Turpin.....andy@latitude38.com.....ext. 112  
Associate Editor.....LaDonna Bubak.....ladonna@latitude38.com.....ext. 109  
Advertising Sales.....John Arndt.....john@latitude38.com.....ext. 108  
Advertising Sales.....Shawn Grassman.....shawn@latitude38.com.....ext. 107  
Classified Sales.....Mary Briggs.....class@latitude38.com.....ext. 104  
General Manager.....Colleen Levine.....colleen@latitude38.com.....ext. 102  
Production/Web.....Christine Weaver.....chris@latitude38.com.....ext. 103  
Production/Photos.....Annie Bates-Winship.....annie@latitude38.com.....ext. 106  
Bookkeeping.....Helen Nichols.....helen@latitude38.com.....ext. 101

Directions to our office.....press 4  
Subscriptions.....press 1,4  
Classified.....class@latitude38.com.....press 1,1  
Distribution.....distribution@latitude38.com.....press 1,5  
Editorial.....editorial@latitude38.com.....press 1,6  
Calendar.....calendar@latitude38.com  
Other email.....general@latitude38.com.....Website: www.latitude38.com

Please address all correspondence by person or department name

15 Locust Avenue, Mill Valley, CA 94941 • (415) 383-8200 Fax: (415) 383-5816

**VIDEO TOURS OF OUR YACHTS  
AVAILABLE ONLINE!**

*Tayana 54  
Deck Saloon*

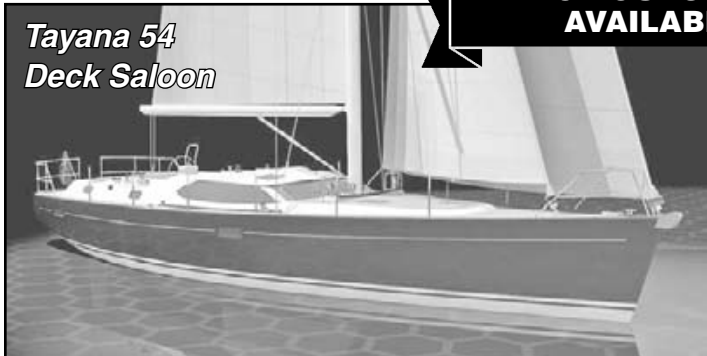

**NEW TAYANA 54 DECK SALOON**

Performance cruiser by Bill Dixon. Custom built to your specifications by Tayana. Two, three and four stateroom options available.

*Tayana 58 DS*



**TAYANA 58 DECK SALOON**

World famous Tayana 58 Deck Saloon. Fast and stable, custom interior. More than 100 hulls built!

*Tayana 64 Deck Saloon*



**TAYANA 64 DECK SALOON**

Robb Ladd design. Center or twin cockpit. 18-ft beam and long waterline. Modern looking bluewater cruiser.



**TAYANA DYNASTY 72**

Designed by Bill Dixon/Andrew Winch. Cruise in luxury on this 72-footer with 20-ft beam. Many interior plans to choose from. Fast and spacious.



**2005 TAYANA 48 CC**

Like new and loaded. 500 hours on Yanmar 75 turbo. LeisureFurl, electric winches, KVH 33 Imarsat phone. **\$489,000**



**2000 BENETEAU FIRST 40.7.** Race ready with many upgrades like larger motor, oversize primary winches, carbon spin pole, professionally faired. **\$189,000**



**1984 TAYANA V-42** aft cockpit cutter. Mast has new LPU paint, rigging & wiring. Raymarine pkg. incl. AP, radar, GPS plotter AGM batteries. Full cockpit enclosure, 3 genoas, spinn w/sock, extensive equip. list **\$149,500**



**1988 HANS CHRISTIAN 41 Molokai** In as fine a condition as one will hope to find in a yacht of this caliber. Fully equipped. **\$225,000**



**1978 MARINER 36 CUTTER**

Rare Tayana-built Mariner 36 in great shape and ready to go cruising. Many recent upgrades including new main and rigging.



**1987 MORGAN 41 CLASSIC.** Modernized version of Charlie Morgan's very popular Out-Island 41. Updated inter. design; improved underbody w/fin keel. **\$99,900**



**1977 TAYANA 37 CUTTER** New Yanmar diesel with 60 hours. Aluminum mast with in-boom furling and new rigging. Chartplotter, radar, windvane.



**2007 TAYANA 48 DECK SALOON** Our most popular 2-stateroom 2-head model. You can still add any factory options. Many extras at a discounted price. Ready to ship. **\$430,000**

*Pacific Yacht Imports*

2051 Grand Street, Alameda, CA 94501

[www.pacificyachtimports.net](http://www.pacificyachtimports.net)

*We're at Grand Marina*

Dave Wolfe, Neil Weinberg, Keith Rarick

Tel (510) 865-2541 Fax (510) 865-2369

[tayana@mindspring.com](mailto:tayana@mindspring.com)





# Successfully Selling Boats in Mexico since 1998

Looking to buy a boat to cruise south to Mexico or beyond?  
The boat you are looking for is either in Mazatlan or La Paz.  
These are proven, cruise ready boats, all have been outfitted, and  
all have made the trip from the U.S., Canada or other countries.



**61' NORLUND** flybridge  
cockpit by Ed Monk, 1975  
\$249,000



**44' PETERSON**  
(2 to choose from)  
cutter, 1976  
\$115,000



**42' HYLAS CC**  
cutter sloop, 1987, \$159,000  
**45' HYLAS 455 CC**  
cutter, 1995, \$159,000



**41' PEARSON RHODES**  
sloop, 1966  
\$69,500



**38' SHANNON**  
cutter, 1980  
\$109,900



**37' RAFIKI**  
cutter, 1978  
\$69,500



**36' UNION POLARIS**  
cutter, 1979  
\$62,500



**30' CAPE DORY**  
cutter sloop, 1983  
\$38,500

Size	Brand/Model	Year	Price
<b>SAIL</b>			
86	Schooner charterer	1970	70,000
55	New Zealand steel ketch	1980	199,000
53	Mason cutter	1983	320,000
51	Formosa cutter ketch	1974	138,000
46	Hunter 466 cutter	2002	219,000
46	Hunter 460 cutter sloop	2000	235,000
45	Hylas 455 cutter	1995	245,500
44	Irwin CC sloop	1987	89,000
44	Miller 44 CC cutter	1980	138,000
44	Kelly Peterson	1979	138,000
44	Peterson cutter	1976	115,000
43	Hunter 430	1995	159,900
43	Camper Nicholson	1970	99,000
43	Nautor Swan sloop	1969	118,000
42	Hylas CC cutter sloop	1987	159,000
41	Seawind	1977	55,000
41	Rhodes by Pearson	1966	69,500

Size	Brand/Model	Year	Price
40	Simpson catamaran	2005	299,000
40	CS sloop	2001	149,000
40	Hardin Sea Wolf ketch	1978	59,000
38	Shannon cutter	1980	109,900
37	Bruce Roberts ketch	1985	66,900
37	Endeavour 37.5 A ctr ketch	1979	59,900
37	Hunter cutter	1979	38,500
37	Rafiki cutter	1978	69,500
37	Tayana cutter	1976	79,000
37	Tayana ketch	1975	79,900
36	Union cutter	1983	89,900
36	Union Polaris cutter	1979	62,500
36	Chung Hwa Magellan ketch	1979	39,900
36	Chung Hwa Magellan ketch	1977	45,000
36	Westerly Conway ketch	1976	38,900
35	Spencer sloop	1966	29,500
34	Cal sloop	1977	34,000
33	Bristol channel cutter	1950	39,500

Size	Brand/Model	Year	Price
32	Freedom sloop	1984	50,500
32	Kettenburg sloop	1978	26,000
31	Pacific Seacraft Mariah cutter	1979	68,000
31	Elizabethan sloop	1976	21,500
30	Cape Dory	1983	38,500
<b>POWER</b>			
61	Norlund flybridge cockpit	1975	249,000
60	Gladding & Hearn converted tugboat	1960	245,000
48	Bluewater Coastal	1991	172,000
45	CHB sedan trawler	1981	169,000
42	Grand Banks trawler	1970	69,000
40	Hatteras convertible sportfish	1968	95,000
39	Bayliner 3988	1998	225,000
39	Sea Ray Express	1989	80,000
30	Baja performance cruiser	1997	699,900
23	Bayliner 2650	1986	8,000
23	Custom launch	1988	12,200



Ray Watson & Jeannette Sarrasin  
Toll free: 1 (888) 716-7430  
Phone & FAX: 011-52-(669)-913-3165  
E-mail: MazMarine@aol.com  
Compare our listings at: MazMarine.com



Mike Rickman  
Toll free US/CAN: 1 (877) 245-9689  
Phone: 011 52-(612)-123-1948  
Cell: 011 521-(612)-105-6459  
E-mail: LaPazYachts@aol.com





Cruising Yachts, Inc.



Unique to the world's seas, a Jeanneau sailboat is distinctive in its design, performance, comfort and security. As America's largest selling import sailboat, Jeanneau has established its reputation over 50 years as the leader in the world of elegant and distinctive design and uncompromising quality, while maintaining elements of its traditional heritage.

Sun Odyssey 39i



A stunning combination of comfort and performance, the SO 39i offers a large cockpit with twin steering positions, luxurious interior appointments, Burmese teak woodwork and a spacious floor plan.

Sun Odyssey 42DS



See why this is America's largest selling import sailboat. Designed by Marc Lombard and Vittorio Garroni, the SO 42 Deck Salon combines perfection in aesthetic beauty with a spacious and light-filled interior.

Sun Odyssey 45 DS



New for 2008, the 45 Deck Salon combines striking exterior design with the largest cockpit in its class, attractive wraparound windows and a vast, light-filled interior. Limited Availability - Order Now for 2008 Delivery.

Sun Odyssey 45 - \$50K Discount



This is the ideal sailboat whether your plans are for entertaining onboard or long distance cruising. The SO 45 combines the distinctive design, unparalleled performance and luxurious livable space that are hallmarks of a Jeanneau.

Call us today at **888.78.YACHT** or visit

[www.cruisingyachts.net](http://www.cruisingyachts.net)



Navigator

CALIBER YACHTS  
INCORPORATED

See us at the Northern California Boat Show  
Pleasanton, CA | Jan 5 - 13, 2008



# Randall Burg YACHT AND SHIP, INC.

Marina del Rey  
Newport Beach  
San Diego  
Alameda

(310) 574-9449  
(949) 675-5940  
(619) 222-1907  
(510) 865-1934



Open at the Ballena Isle Marina!!!  
info@rbyachts.com • www.rbyachts.com

Brokerage Slips Available in Long Beach, Marina del Rey & Newport Beach.  
Stated Income Loans to \$350,000 starting at 6.5%. Broker Co-Ops encouraged.



**51' MASON OFFSHORE YAWL, 1958**  
New wiring, plumbing & paint in/out, hydraulic windlass, Volvo 71 hp dsl. \$99,000



**46' HUNTER 46, 2000**  
Lots of light below.  
Excellent condition. \$217,000



**50' PIVER**  
Loaded with gear. Sleeps 8 in 4 cabins.  
New rigging & Yanmar diesel. \$169,000



**40' MARINE TRADER, 1978**  
\$79,000



**459 MERIDIAN, 2005**  
\$449,000



**37' RAFIKI, 1978**  
\$71,000



**32' RADON DIVE BOAT, 1992**  
\$104,000



**REDUCED**  
**47' KETTENBURG SLOOP, 1958**  
Fully restored. \$99,000



**48' AMERICAN MARINE GRAND BANKS**  
\$149,000



**FAMILY ADVENTURE YACHT**  
**50' DELTA, 1976**  
Repowered, near total rebuilt.  
49 passenger CG doc. \$482,000



**60' CAPE ISLAND TRAWLER, 1994**  
\$299,990



**38' HANS CHRISTIAN MkII CUTTER, 1983**  
Very well equipped.  
\$135,000



**36' HUNTER, 2003**  
\$128,500



**43' PETERSON**  
\$76,500



**40' BLUEWATER TRAWLER, 1979**  
Pristine long range pilothouse.  
\$175,000



**47' MCKINNA, 1997**  
Aft cabin.  
\$347,500



**52' DEFEVER**  
Located in La Paz.  
\$135,000



**52' CALIFORNIAN, 1988**  
\$289,000



**34' CHB TRAWLER, 1978**  
\$60,000



**REDUCED**  
**42' GRAND BANKS CLASSIC, 1973**  
Well maintained. \$89,000



**REDUCED**  
**50' SEA RANGER, 1986**  
\$239,000



**42' GRAND BANKS TRAWLER, 1974**  
\$139,990



**44' NORSEMAN 447 1983**

The owners of this classic bluewater cruiser have completed a two-year 'once-in-a-lifetime' tour of the South Pacific, and are returning to San Francisco. The yacht performed admirably, demonstrating her ability to handle heavy seas with comfort and stability. Refit in 2007, carefully maintained. Designed by Robert Perry, who refers to this model as his "masterpiece." An opportunity to own a safe, swift, and very elegant yacht at a very reasonable price.

**\$228,000**

LIST YOUR BOAT WITH US AND WE'LL PUBLISH A FREE FULL PAGE AD IN YACHT BUYERS GUIDE UNTIL IT SELLS!

# Happy New Year from

F A R A L L O N E & *Catalina* Yachts

See us  
at the  
San Diego  
Boat Show  
January  
3-6



**CATALINA 309**



**CATALINA 34 Mk II**



**CATALINA 350 MkII**



**CATALINA 42 Mk II**



**CATALINA 440**



**CATALINA 470**



**ALAMEDA OPEN BOAT WEEKEND • JANUARY 12-13**



Catalina 42, MkII, 2000



S & S 40, 1982



Valiant 37, 1978



3 to choose from

Catalina 36



Catalina 30, 1990



Jeanneau 36, 1997



Jeanneau 37, 2000



Hunter 36, 2004



Franz Maas 42, 1972

**NEW CATALINA YACHTS  
IN ALAMEDA**

Catalina 470  
Catalina 42 MkII • Catalina 350  
Catalina 34 MkII • Catalina 309

**NEW CATALINA YACHTS  
IN SAN DIEGO**

Catalina 42 MkII • Catalina 350  
Catalina 34 MkII • Catalina 320

**PREOWNED CATALINAS/ALAMEDA**

Catalina 42 MkII	2000	169,000
Catalina 36 MkII	1995	98,500
Catalina 36	1987	52,000
Catalina 36	1987	55,000
Catalina 34	1987	47,000
Catalina 30	1990	37,000

**PREOWNED CATALINAS/SAN DIEGO**

Catalina 400	2000	185,000
Catalina 36	2001	122,500

Catalina 34	2003	115,900
-------------	------	---------

**PREOWNED SAILING YACHTS  
IN ALAMEDA**

Mikelson 50	1988	319,000
Franz Maas 42	1972	149,950
S&S 40	1982	139,000
Morgan 38	1979	57,500
Jeanneau 37	2000	122,000
Valiant 37	1978	79,500
Jeanneau 36	1997	109,000

Hunter 36	2004	122,000
-----------	------	---------

Islander 36	1975	34,500
C&C 36	1981	43,000
Hunter 29.5	1996	40,000

**PREOWNED POWER YACHTS  
IN SAN DIEGO**

Broward 80	1979	1,390,000
Stevens 70 motoryacht		670,000
Apex Pangs Offshore 2600		29,900

1070 Marina Village Pkwy., # 104  
Alameda, CA 94501  
**T: 510.523.6730**  
F: 510.523.3041

*Exclusive San Diego and  
San Francisco Bay Area  
Catalina Dealer*

*yacht sales*  
F A R A L L O N E  
www.faralloneyachts.com

\*2302 Shelter Island Drive  
San Diego, CA 92106  
*New Location!* **T: 619.523.6730**  
F: 619.523.3041





5 Convenient Coastal California Locations  
 Open 7 Days a Week • We take trades  
**#1 DEALER FOR JEANNEAU & HUNTER IN '07**  
**888.325.4353**  
**www.HSyacht.com**

**YOUR SOUTHERN CALIFORNIA DEALER FOR:**



**YEAR-END CLEARANCE SALE!**



**1993 Columbia 50 - A/P Radar, Diesel - \$115,000**



**2000 Catalina 36 - Very popular model! \$82K**



**1984 Newport 28MKII - A steal at only \$17,900**



**2006 Jeanneau 49 DS - Owner moved up. \$479K**



**2000 Beneteau 461 - 2 cabin/2hd. \$199K**



**1975 Swan 44 - Sleek & FAST! \$129,000**



**2006 Beneteau 343 - Save \$\$ over new. \$132K**



**1997 Catalina 42 - 3 cabin version \$118K**



**1998 Catalina 36 - Sleeps 7. \$80,000**



**2007 Catalina 309 - BRAND NEW! \$95,000**

1984 Newport 28 MKII	\$17,900	1998 Catalina 36	\$89,000	1999 Hunter 410	\$149,500	2004 Hunter 466	\$279,000
2005 Catalina 320	\$139,000	1996 Beneteau 36s7	\$97,000	2005 Hunter 41AC	\$209,000	2000 Jeanneau 45.2	\$259,000
1990 Hunter 32	\$44,000	1987 Catalina 36	\$60,000	1987 Morgan 41	\$99,000	2005 Hunter 46 LE	\$290,000
2002 Hunter 326	\$82,500	1999 C&C 110	\$139,995	1998 Hunter 410	\$142,500	1980 Island Trader 46	\$225,000
2003 Hunter 326	\$77,900	2003 Hunter 356	\$132,500	2002 Hunter 410	2 avail - call	2000 Hunter 460	\$220,000
2000 Catalina 320	\$69,500	2005 Hunter 36	\$148,999	1997 Catalina 42 MK II	\$118,000	2000 Beneteau 461	\$199,000
2004 Catalina 320	\$118,000	1993 Hunter Legend 37.5	\$86,500	1994 Hunter Passage 42	\$139,000	2006 J Boats 46	\$675,000
2005 Hunter 33	\$119,500	2006 Hunter 38	\$192,246	1991 Hunter 42	\$139,000	2001 Catalina 470	\$269,000
2002 Beneteau 331	\$94,500	1999 Hunter 380	\$120,000	2003 Beneteau 423	\$224,000	1999 Catalina 470	\$259,000
1989 Hunter 33.5	\$42,500	1985 Catalina 38	\$53,000	1989 Irwin 43 Mark III	\$145,000	1984 Mayflower Mercury	\$189,500
1988 Schock 35	\$55,000	1984 Catalina 38	\$54,900	2001 Dufour Gib Sea 43	\$160,000	2006 Jeanneau 49 DS	\$479,000
1987 Hunter 35.5	\$65,000	1984 Pearson 385 CC	Call	1990 St. Francis 43	\$199,500	1993 Columbia 50	\$115,000
1990 Hunter Legend 35.5	\$64,900	2005 Beneteau 393	\$175,000	2003 Jeanneau 43DS	\$229,500	1999 Beneteau 50	\$280,000
1988 J Boats 35	\$55,000	2007 Jeanneau 391	\$213,000	1975 Nautor Swan 44	\$129,000	2000 Jeanneau 52.2	\$429,900
2004 Hunter 36	\$138,000	1996 Hunter 40.5	\$128,500	2006 Hunter 44DS	\$298,000	1981 Pearson 530	\$289,000
2000 Catalina 36 MKII	\$95,000	2004 Hunter 41 AC	\$229,900	2007 Hunter 44DS	\$272,000	2004 Jeanneau 54DS	\$650,000
2004 Hunter 36	\$148,000	1999 Hunter 410	\$159,000	1999 Hunter 45	\$199,000	2005 Jeanneau 54DS	\$750,000
2002 Catalina MK II	\$134,950	2000 Hunter 410	\$165,000	2000 Hunter 450	\$209,000	2001 Moody 54 CC	\$710,000
1986 Catalina 36	\$57,500	1984 C&C 41	\$89,000	1997 Hunter Passage 450	\$155,000		

**SELL YOUR BOAT FASTER WITH H&S**

- WE SELL MORE 30'- 60' SAILBOATS THAN ANYONE!
- You'll have over 25 salesmen marketing your boat from 5 offices across Southern California.
- Your boat will appear on the leading boating websites, printed boating publications and at boat shows.



**SAN DIEGO | NEWPORT BEACH | MARINA DEL REY | CHANNEL ISLANDS**

**TARTAN**  
YACHTS



TARTAN  
4100  
View at our  
Sales Dock  
  
Call for  
Appt.

TARTAN NEW 5300 • NEW 5100 • 4400  
NEW 4300 • 4100 • 3700 • NEW 3400

**C&C**  
YACHTS



C&C 121 • C&C 115 • C&C 110  
C&C 99 • ONE DESIGN SPECS

**NOW STANDARD ON ALL TARTANS AND C&Cs**  
**Carbon Spar, Epoxy Hull, 15-Year Hull Warranty**



GULFSTAR 50, 1978  
Mexico ready. \$125,000



BENETEAU FIRST 305, 1986  
Diesel, race equipped. \$36,000



WESTSAIL 32, 1976  
Perkins 4-108, new interior. \$58,000



PASSPORT 40, 1982  
Diesel, dodger, nice. \$118,000



30' S-2 CC, 1977  
SOLD

**OPEN BOAT WEEKEND**  
**JANUARY 12-13**

*We need listings now!!*



Klaus Kutz  
Broker Don Wilson  
Broker



TAYANA VANCOUVER 42, 1979  
Cruise ready. Call for appt. \$99,500



WHITBY 42, 1981. Cruising classic,  
clean, roller furling. \$74,500



CASCADE 41, 1971  
Center cockpit. \$59,500



EXPLORER 45 KETCH, 1979  
\$130,000



TARTAN 3400, 2006  
SOLD

ISLANDER 40 ..... SOLD SPARKMAN & STEPHENS 47 ..... SOLD  
PACIFIC SEACRAFT 44 ..... SOLD CAPE DORY 36 ..... SOLD

**Tartan C&C Yachts of San Francisco**  
1070 Marina Village Parkway, Suite 102, Alameda, CA 94501  
(510) 769-9400 • [www.tccsf.com](http://www.tccsf.com)



PASSPORT 40, 1986. Cruise ready,  
well equipped. \$149,500

# THE BOAT YARD AT GRAND MARINA

Formerly Mariner Boat Yard

"Where Service Has Meaning"

**60-TON  
TRAVELIFT**

**Spring Forward  
@ The Boat Yard**



FEATURING  
TRINIDAD  
ANTI-FOULING PAINT BY  
**PETTIT**  
*marine paint*  
RATED "SUPERIOR" by  
Practical Sailor

*The only yard to brush on your bottom paint!*

Dealers for:

**MAX-PROP**  
AUTOMATIC FEATHERING PROPELLERS

**GORI**  
marine

**Webasto**

PACKLESS SEALING SYSTEM  
**SHAFT SEAL**

**LECTRA/san**

**SIDE-POWER**  
Thruster systems

**PROFURL**

**facnor**  
FURLING SYSTEMS INC.

**AQUAMARINE**  
FINE REVERSE OSMOSIS EQUIPMENT

**IT'S SIMPLE!**

Call The Boat Yard at Grand Marina for the Lowest Bottom Prices!

~ COMPARE US WITH THE COMPETITION ~

- Prop and Shaft Work
- Mast & Rigging Repair
- Fiberglass & Blister Repair
- Gelcoat Repair
- Gas & Diesel Engine Service
- LPU Hull & Topside
- Electrical Repair & Installation

**CALL FOR A RESERVATION**

(510) 521-6100 • Fax (510) 521-3684

Located at Grand Marina • 2021 Alaska Packer Place, Alameda

[www.boatyardgm.com](http://www.boatyardgm.com)

\*weather permitting



# Cityyachts

San Francisco's yacht broker  
since 1969

The staff at  
City Yachts wishes  
you health and  
peace in 2008

## YACHTS AND THE CITY



Sabre 34, 1983  
\$59,000



Morgan 41 Out Island  
\$54,900



Passport 40, 1985  
\$150,000



Harbormaster 37  
Ideal City location. \$80,000



Ohlsson 41  
\$34,950



Newport 41 Mk II  
\$39,500



Bayliner 28, 2000  
\$57,000/Offer



Californian Aft Cabin 36, '83  
\$74,900



Classic Coronado 26, \$55,000  
40' SF berth, perfect location



Islander 30 Mark II  
\$9,000

10 MARINA BL. • SAN FRANCISCO, CA 94123 • Toll Free: 877-444-5091 • 415-567-8880  
FAX (415) 567-6725 • email [sales@citysf.com](mailto:sales@citysf.com) • website <http://yachtworld.com/cityyachts>



PLEASE VISIT OUR FUEL DOCK AT GASHOUSE COVE MARINA • OPEN 7 DAYS A WEEK • 9AM TO 5PM

# Golden Gate Yacht Sales

Proud Dealers for



**Sales Position  
Available for an  
Experienced  
Sailboat Person**

Coming Soon  
To Our Docks



2008 Sabre 42 Hardtop Sedan

**We have Buyers! We need listings! Sell your boat with one of California's most active brokerages.**



1969 Admiralty 50 by  
American Marine \$123,500



1996 Beale 47  
\$259,000



1999 Outbound 44  
\$339,000



2000 Beneteau 42  
\$172,000



1964 Cal 40  
\$69,500



2000 Sydney 38 OD  
\$195,000



1990 Sabre 38 Mk II  
\$110,000



1985 Beneteau 38  
\$80,000



1984 C&C 37  
\$75,000





# Yacht Sales & Service - San Diego



**65' J 65 "Brand New Day"**  
Call For Pricing



**42' Hinckley SW, 1987**  
\$329,000



**2002 C&C 121 Xpress 'Anasazi'**  
\$215,000

## FEATURED LISTINGS



**34' J/109, 2004 ~ \$225,000**



**40' Delphia, 2007 ~ \$203,206**

2006	65'	J/65, <i>Brand New Day</i> .....	Call for pricing
1990	46'	Wylie, <i>Stardust</i> .....	\$349,000
1983	46'	Swan Hull #1, <i>Equity</i> .....	\$280,000
1987	42'	Hinckley SW, <i>Alcyone</i> .....	\$329,000
2005	42'	Renzo PT Runner 4.0.....	Call for pricing
2006	42'	Renzo Express 4.0.....	Call for pricing
2006	42'	Renzo Coupe 4.5.....	Call for pricing
2006	42'	Renzo Coupe 4.0.....	Call for pricing
2007	40'	Delphia.....	Base price \$203,206
1998	40'	J/120, <i>Scamp</i> .....	\$220,000
1999	40'	J/120, <i>Blew Bayou</i> .....	\$195,000
2002	40'	C&C 121 Xpress, <i>Anasazi</i> .....	\$215,000

2006	37'	Delphia.....	Base price \$152,127
2001	35'	J/105, <i>Odin</i> .....	129,600
2004	34'	J/109, <i>Zephyr</i> .....	SOLD \$225,000
1980	34'	Peterson, <i>Yellowbird</i> .....	SOLD \$34,500
2007	33'	Cross Current, <i>Electra</i> .....	Call for pricing
2005	33'	J/100, <i>Faster Horses</i> .....	SOLD \$119,000
2007	33'	Delphia.....	Base price \$130,823
1979	32'	Lobster/swordfish, <i>Amber K</i> .....	\$60,000
1984	29'	J/29, <i>Zulu</i> .....	\$25,000
2007	25'	Hunt Harrier.....	\$175,000
2004	26'	J/80, <i>Jim</i> .....	SOLD \$32,000
2001	26'	J/80, <i>Whiplash</i> .....	Pending \$31,000

**Sell your boat with us we are always looking for quality listings.**



Yacht Sales & Service  
- San Diego

2330 Shelter Island Dr. #106  
San Diego, CA 92106  
SD office: (619) 224-6200  
SF office: (408) 218-2828  
Jeff Brown John Bohne Barry Demak  
www.jk3yachts.com



Dealers for  
San Diego  
and Hawaii



# Better Sail Control



*now requires less effort...*

Garhauer's adjustable genoa car system is the answer to leaving the cockpit and going forward to move the genoa car with every wind shift and sail adjustment.

Experience better sail control with less effort. With four to one purchase, you can now easily control the travel of a block on any track from a single line led aft.

This is a four piece system consisting of two control cars and two end controls (port & starboard). A single line threads thru the two horizontal blocks on the easily-installed track cars for each track. Your genoa sheet slides thru the pivoting vertical block and back to the winch.

Available in track widths of 1 and 1-1/4", built with rock solid durability that all Garhauer hardware is known for.

Now tack better and spend less:

**E-Z G-1UB 1 in. track \$242.00**

**E-Z G-2UB 1-1/4 in. track \$302.50**

**E-Z G-3 1-1/4 in. track \$363.00**

**optional swivel cams available: \$96.80 per pair**

**for sailboats  
25-30' LOA**



**E-Z G-1UB**

**Optional  
swivel cam on slide**

**for sailboats  
30-36' LOA**



**E-Z G-2UB**

**Optional  
swivel cam on slide**

**for sailboats  
37-47' LOA**



**E-Z G-3**

**Optional  
swivel cam on slide**



1082 West Ninth Street,  
Upland, California 91786

Phone: (909) 985-9993  
FAX: (909) 946-3913

email: [garhauer@garhauermarine.com](mailto:garhauer@garhauermarine.com)  
<http://www.garhauermarine.com>



# Flying Cloud Yachts



**Hans Christian**

**GEMINI**

Sail • BROKERS • Power

MEMBER  
BoatWizard  
M.L.S.  
YACHTWORLD.COM



6400 Marina Dr., Long Beach, CA 90803

Phone (562) 594-9716 Fax (562) 594-0710



**NEW 105Mc - GEMINI, 2008**  
Best selling cruising catamaran in the U.S.!  
\$154,500



**57' BOWMAN KETCH, 1978**  
Five hours on rebuilt 110hp Perkins. New electronics. Top-quality bluewater cruiser. \$249,000



**36' CATALINA SLOOP, 2001**  
Better than new! Extensive upgrades include Avon RIB with 15hp OB. \$119,500



**47' GIL'S CHOY CATAMARAN, 2002**  
Ready to cruise the South Pacific today!  
Everything as new, fully equipped. \$400,000



**42' CATALINA(s), 1992 & 1997**  
New diesel, fresh sails, 2 & 3-stateroom layouts. Very nice! From \$115,000



**42' WESTSAIL CUTTER, 1974** Only 400 original hours on 35hp Perkins. Great liveboard with beautiful interior. A must see! \$113,000



**37' C&C, 1984**  
Pristine condition! Low hours on Yanmar diesel. Loads of upgrades! \$74,500



**35' CHARTER CATS WILDCAT, 2001**  
Space & performance in ready to cruise cat. 4 strms, hard bottom dinghy, good electronics. \$209,000



**30' ERICSON 30+, 1985**  
Quality production & sailing ability. Needs some cosmetic work. \$18,000

Web site: [www.yachtworld.com/fcyachts](http://www.yachtworld.com/fcyachts) • email: [flyingcloud@verizon.net](mailto:flyingcloud@verizon.net)



**45' HUNTER SLOOP, 1999**  
Very clean and sharp, shows little use. Just reduced, serious seller. \$199,500



**43' CONTESSA SLOOP, 1978**  
Performance designed by Doug Peterson. Quality construction. Must see! \$139,000



**42' PEARSON KETCH, 1978**  
Aft cockpit, aft stateroom cruising ketch, excellent construction. \$79,950



**41' NAUTOR'S SWAN, 1973**  
Clean and ready to sail. New LP and new bottom paint in 5/07. 120,000



**40' CARROL MARINE TRIPP 40, 1991**  
Beautiful boat! *Sailing World's* Boat of the Year People's Choice Award. \$64,900



**42' BINGHAM DOREANA KETCH, 1983**  
Well equipped, beautifully finished, easy to sail. Strong, seaworthy, ready to cruise. \$59,000



**41' YORKTOWN, 1985, \$44,500**  
**39' YORKTOWN, 1976, \$39,500**



**38' HANS CHRISTIANS 1980-1986**  
From \$99,000



**36' CATALINA SLOOP, 1984**  
Very clean. Owners moved out of country - need offers! \$49,500



**36' C&C SLOOP, 1981**  
Clean, good sails and equipment, FAST. \$45,900



**36' ISLANDER SLOOP, 1981**  
Meticulously maintained! New Universal diesel, new upholstery. Many upgrades. \$69,500



**35' CAL CRUISING SLOOP, 1974.** Hard to find cruiser w/big interior. 90 hours on rebuilt Perkins. 2 fuel tanks hold 170 gals. \$39,000



**35' ALLIED SEABREEZE, 1964**  
Classic Plastic with beautiful lines. In great condition. Yanmar diesel. \$29,500



**32' DOWNEAST, 1976**  
Clean pocket cruiser. Low hours on new Volvo diesel! \$45,000



**33' RANGER SLOOP, 1974**  
Tall rig, race sail inventory, new mast and standing rigging. Zodiac & outboard. \$13,500



**30' BABA CUTTER, 1983**  
Low hours on Yanmar diesel. Serious seller, priced right! \$55,000

Some boats shown may be sisterships.



Poop.

Poop.

Poop.

## It feels kinda dirty, that poop just hanging out there, doesn't it?

That's because it is dirty. Nasty. And stinky. It even sounds like what it is – **POOOOP**. And that's why it doesn't belong anywhere near our oceans or waterways. But can you believe that's exactly where lots of it is dumped each year by those masquerading as boaters and fishermen, but are actually the enemy of great Mother Nature herself? Not only is this material far from scenic, it can also spread biological contaminants linked to infectious hepatitis and can lead to diarrhea and dysentery. So join us, true boaters and anglers, lovers of the outdoors and all of its beauty – rise up against these offenders protect our beautiful oceans and waterways and spread the word: **DUMP AT THE PUMP**. To find a pump out station near you visit **DBW.CA.GOV**.

If it's **YOUR** boat, it's your **RESPONSIBILITY**.



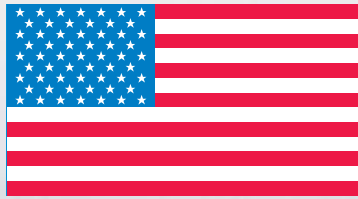

**Along with a great place to berth your boat, San Leandro Marina offers you a wealth of recreational opportunities...**

- **27 holes of championship golf**
- **A waterfront hotel**
- **Fine dining at 2 restaurants overlooking the water**
- **40 acres of shoreline park and picnic sites**
- **300 acres of tidal wetlands on the Bay Trail**
- **2 active yacht clubs**



**(510) 357-7447**

[www.ci.san-leandro.ca.us/slmarina.html](http://www.ci.san-leandro.ca.us/slmarina.html)



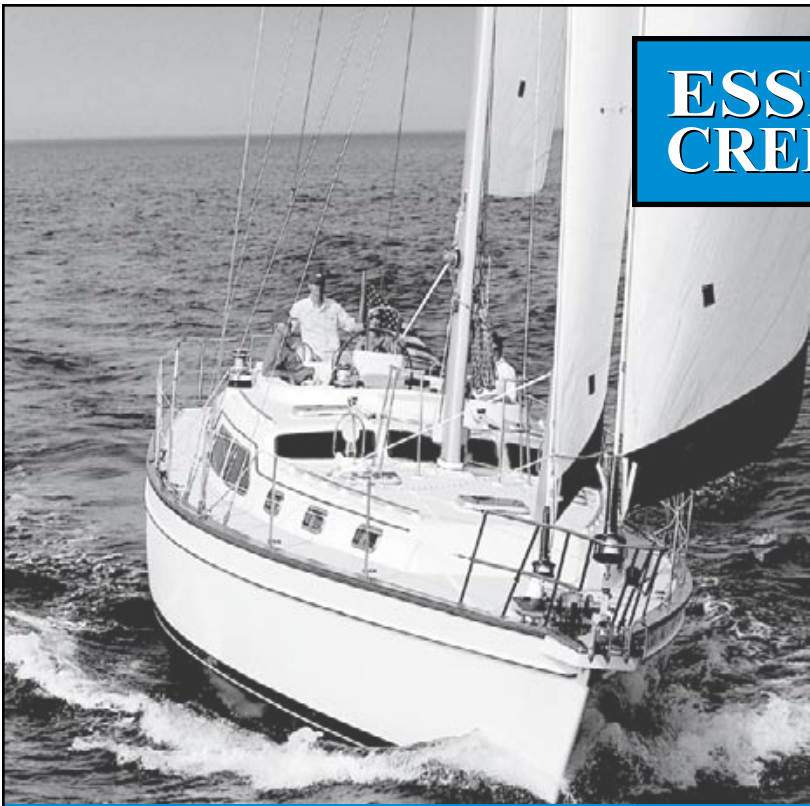

**ESSEX  
CREDIT**

NEW - USED - REFINANCE

# Boat Loans Made Easy®



Let our 26 years of experience go to work for you!

**Linda Carroll**

866-377-3948 ext. 7215

[www.essexcredit.com](http://www.essexcredit.com)

EQUAL CREDIT OPPORTUNITY LENDER

Loan Amounts from \$15,000      Instant Loan Approvals\*  
Zero Down Program\*      90 Days to First Payment\*

\*(Subject to Loan Program Guidelines and Credit Approval)      Reference Code =MAR931

## FULL SERVICE BOATYARD

**WINTER Haulouts for  
Bottom Painting**

**Interlux** Small yard offers specialized service.  
[yachtpaint.com](http://yachtpaint.com)

**NEW  
MARINE  
DIESELS**



**Perkins DIESELS**

SALES  
SERVICE  
PARTS

**10% OFF**

**GENUINE PERKINS PARTS**

Mention this ad ~ Good until 1/31/08  
Perkins Authorized Master Service Dealer

*We ship  
worldwide!*



#11 Embarcadero Cove  
Oakland, CA 94606

(800) 400-2757  
(510) 534-2757

Two blocks from West Marine

[www.britishmarine-usa.com](http://www.britishmarine-usa.com)

## COAST MARINE

**& INDUSTRIAL SUPPLY INC.**

398 Jefferson St. San Francisco - On the Wharf.

Call **Bruce Becker** or **Clark Atkinson**  
(415) 673-1923      (415) 516-4860

**800-433-8050**  
Fax (415) 673-1927



**LIFE RAFT**  
Sales & Service

**U.S.C.G. Approved Testing Facility**

- ★ U.S.C.G. life raft facility for Solas commercial yacht and fisherman rafts
- ★ COMAR DEBARKATION LADDERS
- ★ COMAR PILOT LADDERS
- ★ COMAR WORK LADDERS
- ★ All U.S.C.G. approved



**GUINNESS** "World's longest tested ladder 320ft."  
WORLD RECORD

Major Distributor for:



**Pains Wessex**  
Safety Systems

**STEARNS**



IN SAN DIEGO CALL OCEANS WEST 619 544-1900

# NELSON *Yachts*

# LIST YOUR BOAT!

www.nelsonyachts.net  
(510) 337-2870 • (877) 517-8281

Chad Freitas     Justin Scott  
Ruth Scott, Broker



**HUDSON  
FORCE 50,  
1974**

Spacious, multi-level,  
inside steering,  
large open decks.

**Just  
\$189,000**



**DEFIANCE**

**41' SHOCK,  
1984**

Ready to race  
singlehanded.

**\$68,000**



**47' CHEOY LEE  
OFFSHORE,  
1974**

Just back from Baja  
adventures and ready  
to go again.

**\$95,000**



**OLSON 40**

**Prime Time**

Reduced price!  
Ready to race.

**\$69,000**



**PETERSON 34  
CONTESSA-BUILT  
OFFSHORE  
ONE DESIGN**

**Bulldog**

**\$37,000**



**SILVERTON 34,  
1985**

Ready for fishing.  
Great liveboard.

**\$49,900**



**UNIFLITE 32**

A comfortable and  
versatile cruiser.

**\$24,400**

**SAIL**

50' Hudson Force, '81.....189,000  
45' Explorer, '79.....Inquire  
41' CT Yankee Clipper, '74 ..... Make Offer  
40' Fast, '80 .....15,000  
40' Farr One-Ton, '81 .....Inquire  
39' Vagabond cutter, '75 .....89,900  
33' 11:Metre, '90 .....Inquire  
33' Cape Caribe, '73 .....23,000  
32' Westsail, '75 .....60,000  
32' Columbia 5.5 Sabre, '67 ..... Make Offer  
30' Carter, '76 .....19,950  
29' Cal 2-29, '72 .....13,900

28' Albin sloop, '82 .....14,900  
28' Wylie Hawkfarm, '78 ..... Make Offer  
27' Hunter ..... Inquire  
27' Catalina, '79 ..... Make Offer

**POWER**

35' U.S. Military Amphibious, '63 90,000  
32' Uniflite .....24,400

**NEW HUNTERS**

21.5' Hunter 216, demo '04 .....13,499  
17' Hunter 170, new '06 .....7,599  
14.5' Hunter 146, new '06 .....4,999  
14' Hunter 140, new '06 .....4,499  
10' Hunter Xcite, new '05 .....2,599



# SPECIALIZING IN BLUEWATER CRUISING YACHTS

Visit our website at [www.vallartayachts.net](http://www.vallartayachts.net) for our complete inventory of more than 60 quality yachts.



50' Gulfstar



46' Beneteau



45' Jeanneau



45' Liberty



40' Passport



38' Catalina

Nick and Carol Rau  
Paradise Village Marina

[www.vallartayachts.net](http://www.vallartayachts.net)  
[nick@vallartayachts.net](mailto:nick@vallartayachts.net)

Ph/Fax: 011-52-322-297-2249

Local Cell: 044-322-227-2944

US: 314-667-4111 (rings in MX)



J/160 SYREN

Start the New Year out with the best J/160 on the planet, Syren at \$799,000 and right here in Paradise!

Exclusive Mexico Dealer for Sabre and Back Cove Yachts



VALLARTA YACHTS S.A. DE C.V.

NEW COAST FABRICS  
EST. 1972



Distributor to the automotive and marine aftermarket.

New Coast Fabrics is a distributor for



Polish and Plastic, Canvas and Vinyl Cleaners

**Inflatable Boat Cleaner** is an easy-to-use biodegradable cleaner. Dissolves dirt, oil, creosote, diesel soot and scuff marks on inflatable boats, fenders, rub rails, etc.

**Super Swabby Bilge Cleaner** dissolves oil, grease, gasoline, scum and sludge, leaving a clean fresh scent. Biodegradable.

**Boat Wash with Carnauba Wax** cleans and maintains waxed finishes on boats, cars, planes and recreational vehicles.

We also carry complete lines of marine vinyls, carpets and WeatherMax outdoor fabric.

NEW COAST FABRICS

1955 Davis Street, San Leandro, CA

800.772.3449

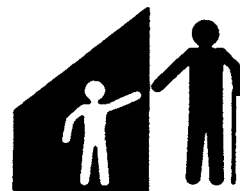

AGAPE VILLAGES

**FOSTER CHILDREN NEED YOUR HELP!**



Donate your boat to support

**AGAPE VILLAGES**

Tax Deductible

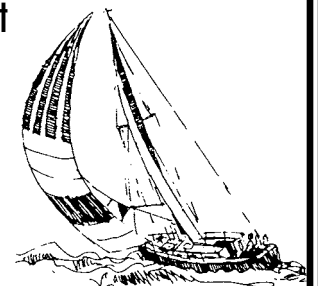

**1-800-513-6560**

See us at the 2008 Seattle Boat Show

Concourse Booth 2412

Take Advantage of the Lowest Prices of the Year.

Boat Show Pricing From Jan. 15 th to Feb. 15th.

Some Items Limited to Stock on Hand.

See us in Seattle for the best brands and advice you can trust.



Cold in Cal? See our Espar dealers in California

A to Z Marine San Diego

Boat Guys Alameda

Swedish Marine Pt. Richmond

Barnett Marine Greater L.A. area

Espar Heater Systems

**BOAT ELECTRIC** Helping you Cruise in Comfort Since 1968  
(206) 281-7570 • (800) 458-5680  
www.boatelectric.com  
2520 Westlake Ave. N. • Seattle, WA 98109

# Best Buys for Your Eyes

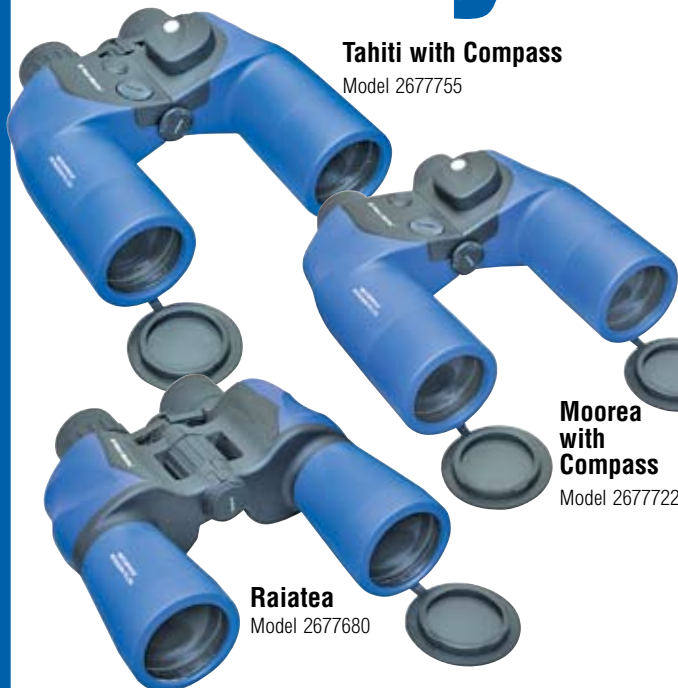

Tahiti with Compass  
Model 2677755

Moorea with Compass  
Model 2677722

Raiatea  
Model 2677680

## Waterproof 7 x 50 Binoculars

When it comes to choosing a pair of binoculars for marine use, it's easy to be overwhelmed by the jillions of available options. But if superb performance at an affordable price is what you want, you can comfortably narrow your focus to one binocular brand—West Marine's Island Series binoculars.

Our complete line of marine binoculars combines truly superb optical performance with rugged, waterproof and fog-proof construction at prices that make them exceptional values. But you don't have to take our word for it. *Practical Sailor* magazine's August 2006 issue rated our Tahiti "Excellent" and a "Best Buy." Better yet, prove it to yourself by stopping by one of our convenient store locations and seeing (and we mean that literally) the difference for yourself!

**West Marine**  
We make boating more fun!

Visit our **Alameda Sailing Superstore!**  
730 Buena Vista Ave. • 510-521-4865

We have 22 stores in Northern California.  
Log onto [westmarine.com](http://westmarine.com) or call **1-800-BOATING**  
to find the store nearest you.

**SURVIVAL TECHNOLOGIES**

**MOM8-A**



**Man Overboard Module**

Manufactured By



Switlik Parachute Co., Inc.  
Trenton, NJ

609.587.3300

info@switlik.com



**YACHTFINDERS****WINDSEAKERS****(619) 224-2349 • Toll Free (866) 341-6189**

2330 Shelter Island Dr. # 207  
 San Diego, CA 92106  
 info@yachtfinders.biz  
 www.yachtfinders.biz



**51' PASSPORT CC, '84**      **\$235,000**  
 Designed to cruise the world, this Passport 51 provides the ultimate in safety and comfort with no compromise to speed and ease of handling.



**47' ROYAL PASSPORT, '95**      **\$398,500**  
 If you are a discriminating buyer looking for a perfect yacht, then *Emerald* should be at the top of your list. Just back from the South Pacific!



**45' HARDIN CC KETCH, '81**      **\$157,000**  
 This classy, offshore vessel with graceful lines and an open and comfortable interior layout will take you around the Bay or around the globe.



**44' PETERSON CC, '76**      **\$119,000**  
 Full of quality upgrades with well-maintained electrical and mechanical systems and custom woodwork in the interior, this is your dream boat!



**44' LANCER PH MS, '80**      **\$99,000**  
 This ultimate spacious motorsailer is well loved and maintained by her current owner. She looks good and goes fast with amazing fuel efficiency.



**42' CATALINA TRI-CABIN, '89**      **\$120,000**  
 This very clean vessel has an owner's private stateroom with separate head and shower and two large guest cabins and guest head with shower.



**41' C&C RACER/CRUISER, '87**      **\$115,000**  
 Win races with a PHRF rating of 72, while providing accommodations for family cruising. *Amity II* has been nicely maintained by original owners.



**41' NEWPORT 41S, '80**      **\$59,500**  
 The Newport 41S has a reputation as a sound, fast, sailing vessel. This one has earned many trophies. Low hours on the 2005 Westerbeke diesel.



**39' BENETEAU 393, '03**      **\$169,500**  
*Opportunity* is a stable, comfortable cruising sailboat offering performance and Beneteau reliability. CE-rated Class A for offshore capabilities.



**34' HUNTER, '85**      **\$38,500**  
 This fast, comfortable, coastal cruiser has custom cabinetry in the salon. Check out the easy-drop mainsail bag and upgraded headsail furling.



**34' CATALINA, '87**      **\$54,900**  
 Extremely clean and well-maintained Catalina 34 with many quality upgrades. Transferable liveaboard slip with marina approval!



**30' CATALINA, '80**      **\$17,000**  
 This yacht is outfitted with the basics for Bay or coastal sailing. She's an honest boat with good bones and tremendous potential for upgrade.



# RICHARDSON BAY MARINA

*formerly Kappas Marina*

## MODERN FACILITIES IN A WELL-PROTECTED HARBOR

**Concrete  
Dock System**

**Well Maintained  
Facilities**

**Beautiful  
Surroundings**

- DEEP WATER BERTHS: BASIN AND CHANNEL DREDGED
- CARD KEY SECURITY SYSTEM
- DOCK CARTS
- PUMP OUT STATION
- AMPLE PARKING
- CLEAN SHOWER AND TOILET FACILITIES
- IN WALKING DISTANCE: MARKET/DELI, LAUNDROMAT, RESTAURANT
- AT EACH BERTH: LARGE STORAGE BOX, METERED ELECTRICITY, WATER, PHONE HOOKUPS

## BERTH YOUR BOAT IN SAUSALITO

**415 • 332 • 5510**

**100 Gate Six Road, Sausalito • Fax (415) 332-5812**

# BETA MARINE

SMOOTHER...  
QUIETER!

Our engines idle smoother and quieter because of our high inertia flywheel. This is one of the many Beta Marine exclusive features that make our diesel engines easier to live with.



**What a Concept!** It is engineered to be easily serviced.

Beta Marine superb propulsion engines, using Kubota diesel 10-90hp including our famous Atomic 4 replacements.

Also available: Marine Generators up to 30 kw.

Regional Dealer:

**BETA MARINE US, LTD.**    **HIRSCHFELD YACHT LLC**

P.O. Box 5, Arapahoe, NC 28510  
www.betamarine.net

265 Gate 5 Rd, Sausalito, CA 94965  
www.engineerite.com

877-227-2473 • 252-249-2473

415-332-3507

info@betamarinenc.com

## Alameda Prop & Machine

Custom Stainless Steel Fabrication & Repair

(510) 522-7899    (800) 774-7899

www.marinepropellers.com

at Grand Marina

## Folding & Feathering Props Are Faster!

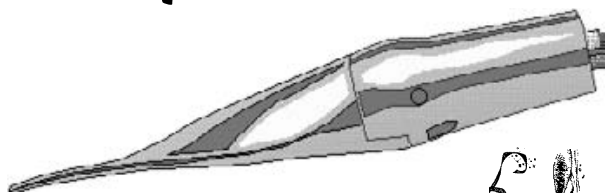

Best Wishes for a  
Happy New Year!

Prop Sales, Repair, Sizing

Wide Selection of USED PROPS

Inboard • Outboard • Folding • Feathering

# Relieves Gas Pains

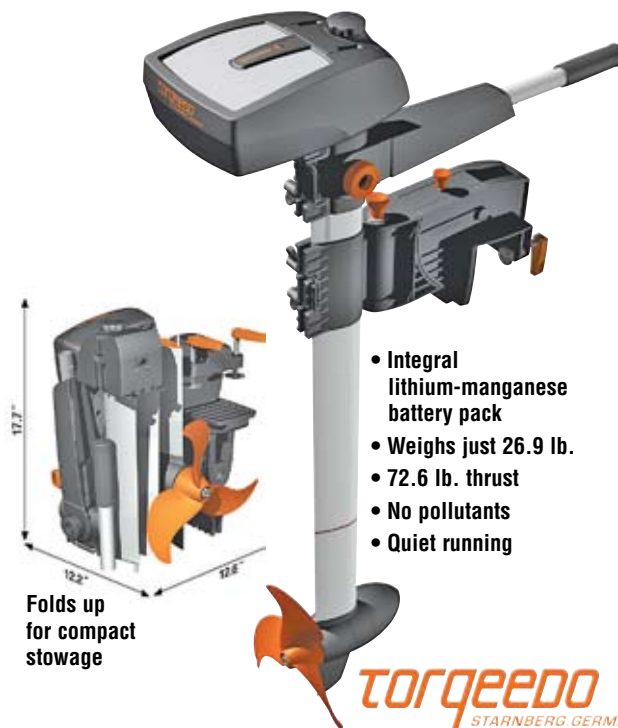

- Integral lithium-manganese battery pack
- Weighs just 26.9 lb.
- 72.6 lb. thrust
- No pollutants
- Quiet running

Folds up  
for compact  
storage

**torqeedo**  
STARNBERG GERMANY

## Travel 801 Electric Motor

Finally! A practical alternative to gas-powered outboards that's ideal for tenders, small keelboats and sportboats. The Torqeedo Travel 801 eliminates the mess and potential hazards of gas tanks along with oil changes, tune-ups, fumes and that infernal racket.

The Torqeedo combines an advanced lithium-manganese battery, highly efficient synchronous permanent magnet motor and variable pitch prop to produce thrust equivalent to a 2 hp combustion motor. It weighs a mere 26.9 lb. (with battery) and can be folded for easy stowage and transport.

If you're ready to say good-bye to gas pains, say hello to a better propulsion solution—the Torqeedo Travel 801 Electric Motor.

Long & Short Shaft versions available.

**West Marine**  
We make boating more fun!

Visit our **Alameda Sailing Superstore!**  
730 Buena Vista Ave. • 510-521-4865

We have 22 stores in Northern California.  
Log onto [westmarine.com](http://westmarine.com) or call **1-800-BOATING**  
to find the store nearest you.





# BALLENABAY YACHT BROKERS



1150 Ballena Blvd. #121, Alameda, CA 94501 ♦ (510) 865-8600 ♦ Fax (510) 865-5560  
2736 Shelter Island Drive, San Diego, CA 92106 ♦ (619) 523-1151

♦ [www.ballenabayyachts.com](http://www.ballenabayyachts.com) ♦ [www.trawlers.com](http://www.trawlers.com) ♦ [www.yachtworld.com/ballenabay](http://www.yachtworld.com/ballenabay) ♦



California dealer for  
**Valiant Yachts**

**New 42' Valiant  
Coming in March 2008**



**33' MASON CUTTER, 1987**  
Bristol condition. Professionally maintained. A must see boat! **\$99,500**



**39' FAIRWEATHER, 1989.** Proven ocean cruiser and great liveboard. **\$140,500**



**41' COOPER PILOTHOUSE, 1981**  
Comfortable, bluewater-capable boat. **\$95,000**

**Check our Web sites for other fine listings!**

## THE PATRON SAINT OF CANVAS...



**ST. ARBUCK**  
AND THE CREW  
WISH YOU A VERY

*Happy New Year!*

## Custom Canvas & Interiors



The Gianola Family has been designing and fabricating custom canvas and interiors since 1969. Gianola & Sons offers you the best in quality, more choices, and personal service.



360 Gate 5 Road  
Sausalito, CA 94965  
(415) 332-3339  
[www.gianolacanvas.com](http://www.gianolacanvas.com)

*Margaret W Fago*  
Yacht Portraits ~ now in Oil



Margaret's Studio-1524 Mozart St, Alameda, CA  
www.margaretfago.com  
510 522-1309 mwfago@earthlink.net

## GLEN COVE MARINA



*Located on the Carquinez Straits*

- 135-ft. Guest Dock
- Yacht Clubs Welcome
- Café & General Store
- Picnic & Event Areas
- Great Fishing Spots Nearby
- Free Wireless Internet
- Pump Out
- Security
- Showers & Laundry

*Now Available:*

24-36 ft. Covered Berths • Up to 55 ft. Uncovered Berths

**GLEN COVE MARINA 707-552-3236**

2000 Glen Cove Road, Vallejo, CA 94591

www.glencovemarina.net • glencovemarina@gmail.com

# A Flare For The Dramatic



**ORION**

## Orion SOLAS-Approved Flares

You don't want to think about it. We don't want to think about it. But good seamanship demands that each of us be prepared for on the water emergencies in order to prevent avoidable dramas.

When the unthinkable happens, you want to attract as much attention as possible from potential rescuers. Which is why you want the brightest, longest burning, highest flying flares you can get your hands on. And SOLAS-approved flares are the best you can buy.

Waterproof, easy to fire and extremely bright, SOLAS flares significantly exceed US Coast Guard requirements. The dramatic difference has to be seen to be appreciated. And, after all, being seen is what it's all about.

West Marine has Orion SOLAS-approved flares in several styles for your boating safety: Red Parachute Flare, Red Handheld Flare and Orange Smoke Canister.

**West Marine**  
We make boating more fun!

Visit our **Alameda Sailing Superstore!**  
730 Buena Vista Ave. • 510-521-4865

We have 22 stores in Northern California.  
Log onto [westmarine.com](http://westmarine.com) or call **1-800-BOATING**  
to find the store nearest you.



# We Still Offer More!



**Making boating easier – and more fun! – is what a marina should be all about.** That's why Oyster Cove Marina rates number one with many Bay Area boaters. It's an exclusive yet reasonable facility of 219 berths, accommodating pleasurecraft in slips up to 60-ft long. **Oyster Cove is the private Peninsula marina closest to bluewater boating.** Want to cruise to Sausalito, lunch at Tiburon, or sail to Angel Island? How about a day's fishing outside the Gate, or a weekend at the Delta? No other private Peninsula marina is better situated or offers nicer, fresher surroundings.

## OYSTER COVE MARINA

385 OYSTER POINT BOULEVARD #8A,  
SOUTH SAN FRANCISCO

**(650) 952-5540**

- Berths 30 feet to 60 feet
- Double Finger Concrete Slips
- Telephone Available
- Five Minutes from SFO
- Heated Dressing Rooms & Showers
- Laundry Room
- Nightly Security Patrol
- Complimentary Ice
- Cable TV/High Speed Internet
- Recently Dredged
- End Ties Available at \$5.75/Ft!

BayRisk Classic

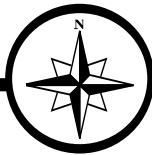

**BayRisk** Insurance Brokers, Inc.

800-647-2025

Visit our Website [www.bayrisk.com](http://www.bayrisk.com)

1920 Minturn Street • Alameda, CA 94501

*in Southern California...*



*A First Class Full Service Facility Serving the Entire Pacific Coast  
150 Ton & 30 Ton Travelifts*

## VENTURA HARBOR BOATYARD

Open 6 Days a Week!

Competitive Rates ~ Professional Staff

*For quality and attention to detail you can count  
on our commitment to your satisfaction.*

**(805) 654-1433**

1415 Spinnaker Drive, Ventura, CA 93001

[www.vhby.com](http://www.vhby.com)

# GET AMERICA'S FINEST BOATING EDUCATION



Location	Phone #	Location	Phone #
Antioch	(925) 377-2628	San Leandro	(650) 592-3604
Marin	(415) 883-6777	San Mateo	(650) 592-3604
Martinez	(925) 377-2628	Santa Clara	(408) 225-6097
Monterey Bay	(831) 624-3333	Santa Rosa	(707) 793-0538
Oakland	(510) 814-1092	Stockton	(209) 951-3862
Sacramento	(916) 782-1240	Vallejo	(707) 552-6287
San Francisco	(650) 871-4447	Walnut Creek	(925) 377-2628

[www.usps.org/localusps/d25/squadrons](http://www.usps.org/localusps/d25/squadrons)

# Optimize Your Spring Lineup



## Get Set for Spring Training

Savvy managers in every sport know that laying the foundation for success begins in the off-season. That's why now is the ideal time for you to scrutinize the sail handling systems aboard your boat.

If you're looking for ways to make your systems run quicker, smoother and stronger, look to West Marine's huge selection of sailboat running rigging.

We've got everything from the latest super-fiber synthetics to affordable standbys in every combination of sizes, colors and constructions. And we've got rigging experts who can help you choose precisely the right lines for every rigging system aboard. We can even splice, taper and strip the lines to ensure they're perfectly tailored to your needs at our Alameda Sailing Superstore.

Get set for a great season now by optimizing your lineup at your nearby West Marine.

**West Marine**  
We make boating more fun!

Visit our **Alameda Sailing Superstore!**  
730 Buena Vista Ave. • 510-521-4865

We have 22 stores in Northern California.  
Log onto [westmarine.com](http://westmarine.com) or call **1-800-BOATING**  
to find the store nearest you.

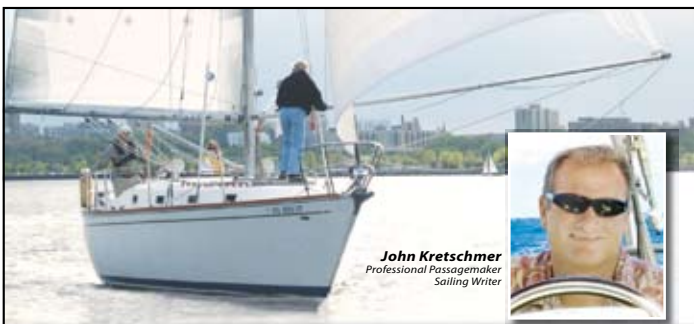

**John Kretschmer**  
Professional Passagemaker  
Sailing Writer

## "I CAN'T IMAGINE SAILING DOWNWIND WITHOUT MY WHISKER POLE"

I make offshore passages for a living and I count on my Forespar® whisker pole. It's an aluminum and carbon, telescoping model that gives me great flexibility when poling out my headsail. It is robust, well engineered and easy to set. When the wind pipes-up I'm able to sail on a deep reach and if it builds more I simply furl the sail, adjust the pole length and keep blasting along.



**FORESPAR**  
CARBON



50/50 Combo

- Poles Available for Boats 16 to 55 Feet
- Aluminum, Carbon Fiber or 50/50 Construction
- Choice of Patented Line Control™ or TwistLock™ Adjustment
- Larger Poles Come with Light & Strong Ultra™ Ends



**FORESPAR**  
WHISKER POLES

Ph: 949.858.8820  
Fax: 949.858.0505

CALL FOR A COMPLETE LINE CATALOG

[www.forespar.com](http://www.forespar.com)



# Pre-Cruised Best Buys



Turn-Key  
Cruiser  
\$800K  
Replacement  
Value!

'01 Hunter HC50/53 • \$498,000



Monterey Slip!

'06 Hunter 45CC • \$330,000



Like New!

'07 Hunter 44DS • \$299,950



Like New!

'05 Hunter 41DS • \$219,950



Fast Cruiser

'83 C&C Landfall 43 • \$129,999



'04 Hunter 386 • \$169,995



'05 Hunter 38 • \$199,000



Reduced!

'05 Hunter 27 • \$49,995

**We're Selling Boats & We  
Can Sell Yours! Call Today!**



**Cruising Yachts, Inc.**

1-888-78-YACHT • [www.cruisingyachts.net](http://www.cruisingyachts.net)

Alameda • Monterey

Sisterships may be shown. Subject to prior sale, change or withdrawal without notice.

# CALENDAR

## Non-Race

**Jan. 1** — New Year's resolution: Sail more!

**Jan. 2-30** — Wednesday Yachting Luncheon Series at St. Francis YC, 12-2 p.m., \$13.50. Enjoy lunch and a dynamic speaker every Weds. All YC's members welcome. More info under the 'Events' tab at [www.stfyc.com](http://www.stfyc.com).

**Jan. 2, 16** — Pt. Fermin Singles Sailing YC invites singles to two monthly meetings. 6 p.m. at Acapulco Restaurant in San Pedro. Info, (310) 427-4817 or [www.pfsyc.com](http://www.pfsyc.com).

**Jan. 4-13** — Northern California Boat Show at the Alameda County Fairgrounds in Pleasanton. Nearly 1,000 boats from 7 to 70 feet, though most sailboats are on the smaller side. Adults \$10; Kids under 15 free. Info, [www.ncma.com](http://www.ncma.com).

**Jan. 6-27** — Free sailing at Pier 40 every Sunday courtesy of BAADS. Info, (415) 281-0212 or [www.baads.org](http://www.baads.org).

**Jan. 8** — Rope Splicing seminar at Sausalito West Marine, 4:30 p.m. Three-strand and braid. Info, (415) 332-0202.

**Jan. 8, 10, 17, 19, 22, 24** — Boat Smart course by Marin Power & Sail Squadron at Kell Education Center in Novato, 7-9 p.m. For info or to register, call (415) 924-2712.

**Jan. 9-Feb. 13** — Basic Coastal Navigation by Flotilla 12-2 at Oakland YC, 6:30-8:30 p.m. Followed by six-week Advanced course. Info, (510) 601-6239 or [nancy@windwave.com](mailto:nancy@windwave.com).

**Jan. 9** — Heavy Weather Sailing class at Sailing Education Adventures HQ at Upper Fort Mason, 7 p.m. Membership required but only \$75 per year. Info, [www.sailsea.org](http://www.sailsea.org).

**Jan. 10** — Single skippers and crew of all skill levels are invited to the Single Sailors Association monthly meeting at Oakland YC, 6:30 p.m. Info, [www.singlesailors.org](http://www.singlesailors.org).

**Jan. 10, 24, Feb. 7, 21** — Sailing Adventure Lecture Series sponsored by Ventura Maritime Foundation at City Hall, 7:30 p.m. Speakers John Neal, the Winson family, Nigel Calder and Quintin Hoard share their wisdom in this four-part series. \$15 per lecture or \$50 for the series. Info, (805) 794-1747.

**Jan. 12** — Get your Amateur (Ham) Technician Class radio license or upgrade your class to General in one day. Study session and exam at Dianne Feinstein Elementary School in San Francisco, \$30. Info, [www.baears.com/index.php](http://www.baears.com/index.php).

**Jan. 12** — Outboard Maintenance class from Sailing Education Adventures, 12 p.m. Membership required but only \$75 per year. Info, [www.sailsea.org](http://www.sailsea.org).

**Jan. 19** — Cruising Before & After lecture from a skipper about to leave and one back after 14 years. Oakland YC, 9 a.m.-noon. Info, (510) 522-6868 or [cwong@oaklandyachtclub.com](mailto:cwong@oaklandyachtclub.com).

**Jan. 22** — Full moon on Tuesday night.

**Jan. 22** — Boating Safety course by Santa Clara Power Squadron. Call DeWayn at (408) 225-6097 for info or go to [www.usps.org/localusps/santaclara/PE.htm](http://www.usps.org/localusps/santaclara/PE.htm) to register.

**Jan. 24-Feb. 2** — Seattle Boat Show at Qwest Field Event Center and the Boats Afloat Show at Lake Union's Chandler's Cove combine to create the largest boat show on the West Coast. Visit [www.seattleboatshow.com](http://www.seattleboatshow.com) for more info.

**Jan. 26** — Join a SF Maritime Park Ranger for a free tour of the unique collection of small craft berthed on Hyde Street Pier, 9:30 a.m.-2:30 p.m. Info, (415) 447-5000.

**January, 1978** — It Was Thirty Years Ago from the article *Origin of the Species*:

The earliest fiberglass production sailboat came out of the molds in Sausalito on Saturday, November 24, 1956. That boat is now more than old enough to swagger into any California bar and demand a drink.

In January of 1957, that same sailboat was loaded on a train and shipped east for the New York Boat Show. The boat had not yet been in the water — she hadn't even been com-

# *We do Power!*

## **Complete engine service for Powerboats & Sailboats!**



*Let us put our 30 YEARS OF EXPERIENCE in marine engines to work for you.*

Rebuilds • Repower • Maintenance • Tune-ups • AC/DC Electrical



### **Lift capacity 35 tons**

Sprayed Racing Bottoms

Full Painting Service

Fiberglass & Gelcoat Repairs

Rigging Repairs & Installation

Electrical Repairs & Installation

Engine Service & Repowering

Propeller Installation & Tuning

Wood Hull Repairs & Caulking

Teak & Non-Skid Deck Repairs

**Chandlery &  
Fuel Dock  
Open 7 Days**

Mon – Fri  
8 am to 5 pm

Sat & Sun  
9 am to 5 pm



**In Berkeley Marina • 510-843-8195 • [www.berkeleymarine.com](http://www.berkeleymarine.com)**



# Introducing the SABRE Spirit

## Now at Sail California



*Sail California is proud to offer the new Sabre Spirit. She's all about simplicity, style and sailing!*

For 35 years, Sabre Yachts has handcrafted sailing yachts with a performance pedigree, all built for people who love sailing and who treasure the exhilarating feeling that a great sailboat design can offer her crew. Sabre asked Jim Taylor to design a daysailer with the style and elegance of sailing yachts of a bygone era, and added to the design mandate blending the performance of a youthful sport boat with "grown-up" ease of handling available with today's modern sailing hardware. With her comfortable and deep cockpit, efficient weekend accommodations and quality Maine craftsmanship, the Sabre Spirit is ideal for San Francisco Bay.

*Call now to own the first boat now at our docks in Newport Beach.*

*Also available ~ the Sabre 386 and 426.*

# SAIL California

Web page: [www.sailcal.com](http://www.sailcal.com)  
Email: [info@sailcal.com](mailto:info@sailcal.com)

**SAIL CALIFORNIA**  
NEWPORT BEACH  
251 Shipyard Way  
Cabin A  
(949) 675-8053  
FAX (949) 675-0584

**SAIL CALIFORNIA**  
SAN FRANCISCO BAY  
1070 Marina Village Pkwy,  
#108, Alameda  
(510) 523-8500  
FAX (510) 522-0641

## CALENDAR

pleted. A special caboose was rented and equipped with tools, and a work crew commissioned to finish the boat as she rolled across the country. This novel idea was a flop, as the weather hit -17° in Cheyenne, Wyoming. The boat was completed in New York, just in time to be presented to the eastern yachting establishment. It created an uproar: Herreshoff's 'frozen snot' had finally arrived.

Frederick Coleman was the man behind the boat, and his firm was Coleman Plastics of Sausalito. The boat was the Bounty II, designed by Phillip Rhodes. (The original Bounty had been a 38-ft wood family cruiser that Rhodes had designed in the late '30s.) It was offered at \$3,877, complete with an inboard engine, at the 1940 Boat Show, and was a success until WWII broke out. Curiously, many of the wood Bounties had been built by a Coleman Boat Works in Florida.

Legend has it that Frederick Coleman had a wood Bounty and that a number of local sailors expressed an interest in having a similar boat. With that impetus, Coleman decided to set up a company to produce the boat in fiberglass, and had Rhodes modify the original for fiberglass construction.

Numerous events over the years have borne out the claims of Bounty quality and craftsmanship. One Bounty back east had a hull-speed encounter with another sailboat and suffered only scratches and the loss of her fiberglass mast. Another fell off the ways and incurred only cosmetic damage. One notoriously reckless local Bounty owner gave the helm to his brother one night and told him to keep a close watch for the Knox buoy. His eagle-eyed brother finally found the buoy with the starboard bow at eight knots. The total damage was the loosening of a few inches of fiberglass tape around the integral water tank that was repaired in less than an hour. Not bad for an 18-year-old boat!

Who built the second fiberglass production boat? A man by the name of Ray Creekmore, and not only were his masts fiberglass, so were his booms — but that's another story.

**Feb. 5-Apr. 29** — Boating Skills and Seamanship course taught by USCGA Flotilla 12 at Sausalito Cruising Club, Tuesdays 7:30-9:30 p.m. \$75 fee. For info, contact Margrit at (415) 924-3739 or [margritkeyes@sbcglobal.net](mailto:margritkeyes@sbcglobal.net).

### Racing

**Jan. 1** — Master Mariners' New Year's Day Race & Chili Potluck at Pt. San Pablo YC in Pt. Richmond. Info, (415) 364-1656 or [www.mastermariners.org](http://www.mastermariners.org).

**Jan. 14** — Sail Selection and Repair seminar for the Singlehanded TransPac at Sequoia YC. Info, [www.sfbaysss.org](http://www.sfbaysss.org).

**Jan. 19** — Richmond YC Little Daddy Regatta. Big Daddy isn't until March 8-9. Info, [www.richmondyc.org](http://www.richmondyc.org).

**Jan. 21-28** — Acura Key West Race Week, the best regatta in the country. Info, [www.premiere-racing.com](http://www.premiere-racing.com).

**Jan. 26** — Three Bridge Fiasco, one of the oddest and most entertaining races ever invented, the first SSS event of the season. Info, [www.sfbaysss.org](http://www.sfbaysss.org).

**Jan. 26** — Sequoia YC's first singlehanded race of the year. Info, John Draeger at [jdraeger@sonic.net](mailto:jdraeger@sonic.net).

**Jan. 27-Feb. 2** — US Sailing's Rolex Miami Olympic Classes Regatta (OCR), a Grade 1 ISAF event with seven Olympic and Paralympic classes. Info, [www.ussailing.org](http://www.ussailing.org).

**Feb. 20-Mar. 1** — San Diego-Puerto Vallarta Race, a 1,000-mile downwind race followed by MEXORC. See [www.sdy.org/pv](http://www.sdy.org/pv) for details.

**Feb. 23** — Island YC Sadie Hawkins Race on the Estuary. Woman skipper, full crew. Chowder Challenge afterwards. Joanne McFee, (510) 521-7442 or [iycracing@yahoo.com](mailto:iycracing@yahoo.com).

**Novice, ancient mariner or olympic rower...  
the fun exercise machine you've been waiting for  
has arrived.**



**The New Whitehall Spirit™ Solo 14**

**Comes fully equipped  
We sell direct and ship worldwide  
Dealer inquiries welcome**

**Watch the video at  
[www.whitehallsolo.com](http://www.whitehallsolo.com) 1-800-663-7481  
See us at the San Diego and the Seattle Boat Shows!**



**YACHT INSURANCE**

**Commercial Operations**

- COMMERCIAL POLICIES  
Marinas, Yards,  
Yacht Clubs,  
Brokers,  
Shipwrights

**Pleasure Yachting**

- YACHT & BOAT POLICIES  
Offshore, Coastal, Inland  
and Liveboards



Lic. #OB21939

**Bill Fowler**

**McDERMOTT COSTA INSURANCE**  
(925) 606-6606 Fax (510) 357-3230  
[bfowler@mcdermottcosta.com](mailto:bfowler@mcdermottcosta.com)

**Port Townsend  
Shipwright's Co-op**



**Celebrating our 25<sup>th</sup>  
Anniversary!**

*The oldest boat yard in Port Townsend!*

**360-385-6138 800-567-8780**  
[www.ptshipwrights.com](http://www.ptshipwrights.com)



# “1<sup>st</sup> IN CLASS”

Available  
To View!



## The New J/122

These three words, ‘1st in Class’ have already been found next to ‘J/122’ many times after the recent introduction of this latest performance J/Boat. Starting right here on San Francisco Bay with the 2007 Big Boat Series where the brand new J/122 TKO took her class in IRC ‘C’. But it’s not a local phenomenon, the J/122 has won on the East Coast in events such as the Manhasset Fall Series and in Europe where the J/122 dominated the 2007 RORC IRC series with six firsts.

Bring the J/122 home to the family and you’ll likely be nominated ‘1st in Class’ by your spouse and kids. For not only will they enjoy the silverware from the race weekends, they’ll enjoy the comfortable sailing motion and the spacious, relaxing accommodations below. Like all J/Boats, the 122 is a sailboat first but it doesn’t leave the rest of life’s pleasures ashore. Both the two or three cabin layout will make for very agreeable cruising for the whole family.



The J/122 is well balanced, has proven performance under IRC and will excite any passionate sailor. Give us a call and have a look at the latest from J/Boats.

“...certainly in terms of feeling and handling the 122 was a joy.” — Andi Robertson, Yachts & Yachting

**Nothing Beats a J/Boat**

**SAIL**  
*California*

Web page: [www.sailcal.com](http://www.sailcal.com)  
Email: [info@sailcal.com](mailto:info@sailcal.com)

### SAIL CALIFORNIA

NEWPORT BEACH  
251 Shipyard Way  
Cabin A  
(949) 675-8053  
FAX (949) 675-0584

### SAIL CALIFORNIA

SAN FRANCISCO BAY  
1070 Marina Village Pkwy,  
#108, Alameda  
(510) 523-8500  
FAX (510) 522-0641

### SAIL NORTHWEST

SEATTLE  
7001 Seaview Ave., NW  
Suite 140  
(206) 286-1004  
FAX (206) 286-1353

## CALENDAR

**July 12** — 30th anniversary of the Singlehanded Transpac from SF to Hanalei. If you’ve been wanting to prove your mettle, this could be your year. Info, [www.sfbayss.org](http://www.sfbayss.org).

**July 14-19** — 15th Biennial Fun Race to Hawaii, aka the Pacific Cup. For details on the race and seminars, visit [www.pacificcup.org](http://www.pacificcup.org).

### Midwinter Regattas

**ALAMEDA YC & ISLAND YC** — Estuary Midwinters: 1/13, 2/10, 3/16. Joanne McFee, (510) 521-7442.

**BERKELEY YC** — Midwinters: 1/12-13, 2/9-10, 2/24. Bobbi, (925) 939-9885.

**BERKELEY YC** — Chowder Races: Sundays through March except when it conflicts with above. Paul, (510) 540-7968.

**CAL SAILING CLUB** — Year-round Sunday morning Lido 14 races, intraclub only. Ed, [racing\\_chair@cal-sailing.com](mailto:racing_chair@cal-sailing.com).

**CORINTHIAN YC** — Midwinters: 1/19-20 & 2/16-17. Allyn Schafer, (415) 435-4812 or [racing@cyc.org](mailto:racing@cyc.org).

**ENCINAL YC** — Jack Frost Series: 1/12, 2/9, 3/8. Charles Hodgkins, [rearcommadore@encinal.org](mailto:rearcommadore@encinal.org).

**GOLDEN GATE YC** — Seaweed Soup Series: 1/5, 2/2, 3/1. Gary Salvo, (916) 363-4566.

**OAKLAND YC** — Sunday Brunch Series: 1/6, 1/20, 2/17, 2/24, 3/2. Steve, (510) 373-3280.

**REGATTAPRO** — West Marine Winter One Design: 1/12, 2/9. West Marine Winter Keelboat: 1/5, 2/2. Jeff Zarwell, (415) 595-8364 or [jzarwell@regattapro.com](mailto:jzarwell@regattapro.com).

**RICHMOND YC** — Small Boat Midwinters: 1/6, 2/3, 3/2. Sue Hubbard, (510) 235-0184 or [www.richmondyc.org](http://www.richmondyc.org).

**SANTA CRUZ YC** — Midwinters: 1/19, 2/16, 3/16. Info, (831) 425-0690.

**SAUSALITO YC** — Sunday Midwinters: 1/6, 2/3, 3/2. J. Rigger, (415) 332-6367 or [race@syconline.org](mailto:race@syconline.org).

**SEQUOIA YC** — Winter Series: 2/9, 3/1. J. Draeger, (650) 244-6529. Redwood Cup: 1/6, 2/24, 3/9. R. Brown, (650) 430-5567.

**SOUTH BAY YRA** — Midwinters: 1/5, 2/2, 3/1. Larry Westland, (510) 459-5566.

**SOUTH BEACH YC** — Island Fever Midwinters: 1/19, 2/16, 3/15, 3/24 (makeup). Info, [www.southbeachyc.org](http://www.southbeachyc.org).

**VALLEJO YC** — Tiny Robbins Midwinters: 1/6, 2/3. Info, (707) 643-1254.

### Mexico, The Season Ahead

**Jan. 29-Feb. 3** — 7th Annual Zihua Sail Fest in Zihuatanejo, Mexico. Five days of parties, contests, potlucks, races, BBQs, auctions and chili cook-offs are what attracted over 100 boats to last year’s event, but the real payoff was raising money for the Nueva Creaciones School for indigenous children. These kids, many of whom are orphaned, can’t attend Mexican schools until they learn to speak Spanish. Last year nearly \$95,000 U.S. was raised — thanks in large part to matching funds raised by the Bellack and Underwood Foundations. To join in the fun and help some needy kids — even if you can’t make it to the parties — go to [www.zihuasailfest.com](http://www.zihuasailfest.com).

**Feb. 5** — Pacific Puddle Jump Kick-Off Party at Rick’s Bar in Zihuatanejo from 2-5 p.m. *Latitude 38* and Rick’s Bar team up to host the first of two get-togethers for South Pacific-bound cruisers. It gives everyone a chance to compare notes and finalize radio skeds, and also gives *Latitude*’s Andy Turpin a chance to interview you and take your photo for the magazine. Open only to people who are Puddle Jumping this year. For details, email [andy@latitude38.com](mailto:andy@latitude38.com).

**WE WANT TO SELL YOUR BOAT! CALL TODAY – DOCK SPACE AVAILABLE!**

# SAIL *California*

Don't wait another day to have the J/Boat Experience, visit our sales dock and choose from pre-owned J/105s, J/109, J/120, J/42 and J/44



**Santa Cruz 52, 2000  
Natazak**

This SC 52 is pristine. Major refit in summer '06: full inshore/offshore racing and cruising equipment. There is no finer SC 52 on the planet. Now on our sales dock for you to view.

Asking **\$629,000**



**REDUCED**

**Andrews 56,  
1994, Charisma**

This performance cruising boat offers speed and comfort with the allure for adventure. Call today to fulfill your cruising dreams.

Asking **\$364,599**



**Back Cove 29  
2005  
Diamond Lil**

Style, grace and performance, what more could you want?

Asking **\$199,000**



**One Design 35  
Hull #18  
Double Trouble**

This boat is RACE READY with an impressive record, truly turn-key, just add crew!

Asking **\$94,900**



**J/120, 1998 Hot Tamale**

This boat is 40' of fun, the J/120 can do it all race and cruise. *Hot Tamale* is turn key to race in Winter Series. On our sales dock! Asking **\$219,000**



**Andrews 56, 1992 Cipango**

Looking to win the Pacific Cup? This is your ride! Asking **\$389,000**



**REDUCED**

**J/105, Wianno, 1998**

See this classic tiller boat, race ready on our sales dock today. Asking **\$87,000**



**SISTERSHIP**

**J/44, 1990, Phoenix**

The perfect sailboat – liveaboard comfort, easily managed by two, offshore durability and speed to win Fastnet and Sydney-Hobart. Asking **\$239,000**

- 56' Andrews 56, '92, *Cipango*.....\$389,000
- 56' Andrews 56, '94, *Charisma*..... Reduced! \$364,599
- 53' HC-50, *Break n' Wind*, '01..... Reduced! \$498,000
- 53' Andrews, '90, *Artemis*\*\*..... Reduced! \$325,000
- 52' Santa Cruz, '00, *Natazak*..... \$629,000
- 45' Hunter 450, '00, *Fall Asea*..... Reduced! \$219,000
- 44' J/44, '90, *Phoenix*..... \$239,000
- 44' J/44, '90, *BJ*\*\*..... New Listing \$275,000
- 40' J/120, '98, *Hot Tamale*..... Reduced! \$219,000
- 40' J/120, '95, *Attitude*\*\*..... \$199,000
- 40' Tripp, '92, *Snake Oil*\*\*..... Reduced! \$85,900
- 40' Elan, '04, *Tupelo Honey*..... Reduced! \$239,000
- 39' Dehler 39, '03, *Wild Redhead*\*\*..... New Listing \$329,500
- 38' Ericson 38-200, '87, *Yankee Rose*\*\*..... Reduced! \$88,500

- 37 Beneteau First 375, '85, *Time Warp*\*\*..... New Listing \$69,900
- 36' J/109, '03, Hull #43, *Doc Holiday*\*\*..... SOLD
- 36' 362 Sabre, '95, *Soledad*\*\*..... SOLD
- 36' J/109, '05, Hull #204, *Commotion*..... \$239,900
- 36' J/109, '06, *Surfer Girl*\*\*..... New Listing \$229,000
- 35' J/35, '84, *Courageous*\*\*..... \$42,000
- 35' J/105, '99, Hull #255, *Roadster*\*\*..... Reduced! \$105,000
- 35' J/105, '99, Hull #235, *Life Is Good*\*\*..... Reduced! \$99,000
- 35' J/105, '98, *Wianno*..... Reduced! \$87,000
- 35' J/105, '02, Hull #523, *Streaker*..... \$139,000
- 35' One Design, '98, *Double Trouble*..... \$94,900
- 34' J/34, '85, *The Zoo*\*\*..... Reduced! \$29,900
- 33' J/100, '04, Hull #9, *Brilliant*\*..... \$134,900

- 33' J/100, '05, Hull #17\*\*..... \$125,000
- 32' Melges, *Emotional Rescue*..... SOLD
- 30' J/92, '93, *Zippy*, Waukesha, WI..... \$54,500
- 30' Sea Ray 300 Sundar, '06, *Sophie Ann*\*\*..... Reduced! \$149,950
- 29' J/29, '81, *Macs*\*..... \$26,900
- 29' J/29, '84, *Jolly J*\*..... \$25,000
- 29' Back Cove, '05, *Diamond Lil*..... \$199,000
- 29' Back Cove, '06, *Desiderata*\*..... \$197,500
- 29' Cobalt 29, '01\*\*..... New Listing \$76,000
- 27' Choate, '79, *Allegro Con Brio*\*\*..... \$17,500
- 26' J/80, '00, *Risky Business*\*\*..... Reduced! \$32,000
- 22' Aquapro Raider 665, '04..... \$44,900
- 20' Harbor 20, '04\*\*..... Reduced! \$22,500
- 19' Alerion Cat, '98, *Whiskers*\*\*..... SOLD

**YACHTWORLD.com**

**OPEN BOAT WEEKEND  
JANUARY 12-13**



\* Indicates So. California Boats  
\*\* Indicates Seattle Boats

# SAIL *California*

Web Site: [www.sailcal.com](http://www.sailcal.com)  
Email: [info@sailcal.com](mailto:info@sailcal.com)

**NEWPORT BEACH**  
251 Shipyard Way  
Cabin A  
Newport Beach, CA 92663  
**(949) 675-8053**  
FAX (949) 675-0584

**ALAMEDA**  
1070 Marina Village Pkwy  
#108  
Alameda, CA 94501  
**(510) 523-8500**  
FAX (510) 522-0641

**SEATTLE  
SAIL NORTHWEST**  
2130 Westlake Ave. N.  
#3  
Seattle, WA 98109  
**(206) 286-1004**



# Harken Furling Systems Unwind



C&C 115 — Bobi Grieger Photo

**FURLING**

## MKIV & CRUISING JIB REEFING AND FURLING SYSTEMS

Furling is easier than ever with Harken's new lines of racing and cruising furlers. Smaller outer drums fit belowdeck and on narrow bows, while larger inner spools increase mechanical advantage. Large bearing races reduce friction for effortless reefing and furling from the safety of the cockpit.

Harken furlers don't require professional installation and leave your headstay intact. Link plates now allow you to raise the drum to clear the anchor, reduce sail chafe, and increase visibility for smooth sailing.



**TECH TIP:** The Jib Reefing & Furling Lead Block Kit (7404) reroutes lines outside the stanchions for a cleaner deck and prevents backlash by keeping tension on the line.

### CHOOSING YOUR SYSTEM

- Log on to [www.harkencompuspec.com](http://www.harkencompuspec.com) for a step-by-step guide
- Contact your local dealer or sailmaker (listing at [www.harken.com](http://www.harken.com))
- Call the Harken Tech Service Team at 262-691-3320

**HARKEN**  
INNOVATIVE SAILING SOLUTIONS

1201 E. Wisconsin Ave., Fremont, WI 53122, Tel: 262-691-3321  
Fax: 262-691-9888, Email: [harken@harken.com](mailto:harken@harken.com), Web: [www.harken.com](http://www.harken.com)

## CALENDAR

**Feb. 8** — Pacific Puddle Jump Kick-Off Party at Vallarta YC in Nuevo Vallarta from 2-5 p.m. *Latitude 38*, Paradise Marina and the Vallarta YC team up to host the final get-together for South Pacific-bound cruisers. For details, email [andy@latitude38.com](mailto:andy@latitude38.com).

**Mar. 1-8** — The 16th Annual Banderas Bay Regatta has expanded to a week of 'friendly racing for cruising boats'. The sailing conditions and the Paradise Marina venue couldn't be better. Everybody plays it safe because they're sailing their homes, and the entry is free. It's the perfect time and place to have family and friends fly down and join you in the tropics. In fact, you'd have to be nuts to miss this one. The Regatta is part of the month-long Festival Náutico Vallarta. For details, visit [www.banderasbayregatta.com](http://www.banderasbayregatta.com).

**April 11-13** — La Paz Bay Fest. This will be the fourth year for this descendant of the (in)famous La Paz Race Week. An event for cruisers that includes races, potlucks, cruising seminars and other fun activities for the family. More info on Bay Fest 2008 will soon be found at [www.clubcruceros.org](http://www.clubcruceros.org).

**May 1-4** — Loreto Fest and Cruisers' Music Festival. This classic Baja event, started to clean up Puerto Escondido, draws a very large crowd of cruisers and Baja land-travellers for a chili cook-off, dinghy races and other water activities, the Candeleros Classic race, and lots of participant-created music. The goals are to have fun and raise lots of money for Mexican charities in Puerto Escondido and Loreto. Visit [www.hiddenpartyachtclub.com](http://www.hiddenpartyachtclub.com).

Please send your calendar items by the 10th of the month to [calendar@latitude38.com](mailto:calendar@latitude38.com). If you're totally old-school, mail them to *Latitude 38* (Attn: Calendar), 15 Locust Avenue, Mill Valley, CA, 94941 or fax them to us at (415) 383-5816. But please, no phone-ins! Calendar listings are for marine-related events that are either free or don't cost much to attend. The Calendar is not meant to support commercial enterprises.

### January Weekend Currents

date/day	slack	max	slack	max
12/29Sat		0224/3.3F	0541	0812/2.5E
	1154	1429/2.0F	1714	2013/3.2E
12/30Sun	0004	0311/2.9F	0623	0905/2.6E
	1301	1539/1.9F	1825	2107/2.5E
12/31Mon	0052	0358/2.6F	0704	0958/2.9E
	1404	1654/2.0F	1940	2205/1.9E
1/01Tues	0141	0443/2.3F	0742	1049/3.2E
	1501	1802/2.2F	2052	2307/1.6E
1/05Sat		0154/1.4E	0458	0748/2.1F
	1032	1358/4.3E	1809	2120/3.2F
1/06Sun	0034	0236/1.5E	0539	0829/2.2F
	1113	1440/4.5E	1849	2157/3.4F
1/12Sat		0051/3.5F	0417	0645/2.8E
	1001	1250/2.3F	1533	1852/4.0E
	2223			
1/13Sun		0131/3.3F	0452	0732/3.1E
	1102	1347/2.3F	1636	1943/3.4E
	2304			
1/19Sat		0100/1.7E	0359	0657/2.6F
	0943	1315/5.2E	1722	2033/4.0F
	2353			
1/20Sun		0201/1.9E	0458	0754/2.8F
	1040	1410/5.5E	1813	2124/4.2F
1/26Sat		0049/3.4F	0402	0637/3.0E
	1015	1258/2.5F	1553	1846/3.4E
	2229			
1/27Sun		0128/3.0F	0440	0722/3.0E
	1113	1354/2.2F	1653	1933/2.7E
	2310			

# Remember when service actually meant something?



## FREE SAIL INVENTORY EVALUATION

Bring in your sails to Quantum today for a free evaluation, and be ready to go come race day.



TM

**Quantum Pacific**  
1230 Brickyard Cove Road  
Point Richmond, CA 94801  
sanfrancisco@quantumsails.com  
510.234.4334

**Los Angeles**  
222 West 'D' St.  
Wilmington, CA 90744  
mtaylor@quantumsails.com  
310.518.2842

**San Diego**  
2832 Canon St.  
San Diego, CA 92106  
reynolds@quantumsails.com  
619.226.2422



# CRUISE OR RACE WITH THE SAME SUIT OF SAILS: UK-HALSEY TAPE DRIVE.



**WINTER DISCOUNTS**  
November – February  
As little as two weeks  
delivery time!

"My Luders 33 Endeavour may be a lot older than your boat, but my UK-Halsey Tape-Drive sails keep you from noticing anything but her speed," says owner Bill Conron.

CONVENIENCE AND  
SATISFACTION FROM  
USING FAST SAILS  
THAT LAST.



## NORTHERN CALIFORNIA

451 W. Atlantic, Suite 115, Alameda, CA 94501

**(510) 523-3966**

Sylvain Barrielle · Synthia Petroka · Jason Crowson · John Herne

[www.ukhalsey.com](http://www.ukhalsey.com) • [sanfrancisco@ukhalsey.com](mailto:sanfrancisco@ukhalsey.com)

## LETTERS

### ↑↓CHEATING IN THE HA-HA?

I just completed the '07 Ha-Ha, and want to express my thanks for the great job the organizers did toward making this a safe and informative start to a cruising experience for my wife and me.

We sailed in a division with two heavy displacement sister-ships and quite a few lighter displacement boats of the same length. We didn't break any records for speed with our boat, but were gratified to find out at the awards ceremony that it wasn't how fast you got there, but how much you sailed in getting there.

But we do think that the Poobah missed awarding a significant prize for the one boat in our division that was able to defy the laws of physics — although he did get the first place award for having sailed all the way. Let me explain:

During the second leg, we sailed side by side with this boat, crossing paths three times during the first day and night. During the second day, the winds were too light for our vessel — we need at least 10 knots of wind to do three knots — so we motored down the rhumb line at 6.5 knots directly toward Bahia Santa Maria. Imagine our surprise to see the sistership that we'd been competing with all day anchor next to us an hour after we got there, saying that they had sailed the entire way. Somehow he must have made six knots of speed in 10 knots of wind directly to Bahia Santa Maria, or perhaps he made more like eight knots — even though his boat has a hull speed of 7.8 knots — if he sailed outside to find winds that no one else could. In either case, he defied the physical laws of the universe. At the least, one would have expected the lighter displacement boats in our division to have beaten a heavy displacement boat that had sailed all the way.

During the last leg of the trip, we needed to get a crewmember to Cabo by a certain time that required we



ELECTRONIC / RICHARD

**Scott Karlin's Newport Beach-based Irwin 43 'Windswept' is not a party to this controversy, but is an example of a Ha-Ha boat that was surprisingly fast under a huge asymmetrical chute.**

make a six-knot average speed during the entire leg. So we sailed directly down the course line wing-on-wing and, whenever the wind fell below 15 knots, brought in the sails and cranked up the engine to maintain the six knots we needed to reach Cabo on time. I believe the entire fleet ran into light winds by the evening of the first day, which can be handled by the lighter displacement sailboats, but not by those of us with heavy displacement boats. But during the 6 a.m. position report, we noted that our miraculous sistership was just ahead of us, outside of Cabo, having "sailed all the way."

I think you need to institute a special prize for sailors who either defy the laws of physics, or have a helping hand from the Almighty with special winds that are denied the rest of the fleet. I plan to notify the factory that they need to find out how they manufactured the sailboat that was produced

# From top to bottom, Svendsen's delivers quality craftsmanship.



## FREE

### Polish and Wax with Bottom Job

Call today to  
schedule your  
bottom job:

**510.522.2886**

Offer Expires  
1/31/08

Svendsen's is a full-service boat yard, performing all aspects of marine repair using the finest **3M** materials. Boasting some of the most experienced craftsmen in the bay area, our experts will handle your boat bottom with care. From thorough sanding and preparation to fine detail painting and finishing. Treat your boat like it's one of the family, because we will.



## SVENDSEN'S BOAT WORKS

Call today to schedule your haulout : **510.522.2886**  
Or schedule your work online at **svendsens.com**

### 3M Superior Products



- Abrasives & Masking
- Sealants and Fillers
- Compounds
- Buffing Pads
- Finishing Materials





passionate about sailing

## SAILING VACATIONS



# Discover your passion with Sunsail

At Sunsail we share your passion for sailing, and have spent over 30 years working to ensure our charters are the best value available. No matter if you're a group on our largest yacht, or a couple on our smallest, you'll get the same Sunsail quality and service that make us the best value in sailing vacations today.

Trust your vacation to Sunsail –  
The company that loves sailing as much as you do...

Call 800 734 8682  
or visit [www.sunsail.com](http://www.sunsail.com)



Caribbean • Mediterranean • South East Asia

## LETTERS

two molds after mine to make it so fast in light winds, so as to retrofit my boat with whatever they did.

Please Withhold My Name To Protect The Innocent

*P.W.M.N.T.P.T.I. — We're not being flip when we say we've got some good news for you — your boat is much faster than you realize. How do we know? Because she has a PHRF rating of about 120, which means if you're only getting three knots out of her in 10 knots of wind, you're missing out on at least half of her potential speed. And make no mistake that the difference in speed between sisterships can be dramatic. For example, if you watch the J/120 class at the St. Francis Big Boat Series, you'll see that the distance at the finish between the best-sailed boats and the less-well sailed boats is very large — and everybody in that class is an experienced racer.*

*There are a lot of seemingly little things that add up to make one sistership much faster than another, particularly with cruising boats. For example, how clean the bottom is, how much weight is being carried, the trim of the sails, the size of the spinnaker, how well the boat is being steered, and the course chosen.*

*In the case of the second and third legs of the Ha-Ha, the way you played the typical north to northwest shift of the winds from morning to afternoon, and then back to the north again at night, made a tremendous difference, not only for the apparent wind angle, which is critical for boat speed, but also for whether you aligned with or crossways to the swell. If you were on the wrong jibe at the wrong time, or even if you were doing rhumb line, you were losing out big time.*

*If you assume that everybody got the same amount of wind from the same direction on those last two legs, check out [www.sailflow.com](http://www.sailflow.com), select the map for the coast of Baja, then click on the Wind Flow Viz map. If you examine the chart over a series of days, you'll see that if you approach Punta Hughes/Bahia Santa Maria from the inside, you're going to be sailing very deep — and therefore very slowly. But if you were coming in from the outside, you'd be on a steaming reach, and therefore have more apparent wind and much more boat speed.*

*By the way, your boat is a rather high-performance, medium-displacement boat, not a heavy-displacement boat. As such, she's at her best — compared to light-displacement boats — in 10 to 15 knots of wind and flat water — such as we usually have in the Ha-Ha.*

*We're very familiar with the boat and skipper that you believe didn't really sail the whole way. He and his boat have done several Ha-Ha's as well as trips to the South Pacific, to the Pacific Northwest and many other places. Not only is he a fine sailor, but he's got a very large and vibrantly colored asymmetrical chute that he trims well and sails on the curl for maximum speed. We were right next to him with Profligate in the early stages of both the second and third legs and found his boat to be very fast, particularly in the light and steady stuff. When he said that he sailed the entire way, there was no doubt in our mind that he did just that.*

*Our suggestion is that the next time you cross paths with the person you suspect of foul play, that you compliment him on his performance, and ask him for tips on how to sail your sistership faster. We bet he'd be happy to take you for a sail to show you what a big asymmetrical can do for performance, and the difference it makes in speed when it's trimmed perfectly. As we said, you've got a terrific boat capable of superb performance, and you'll be thrilled once you learn to extract it.*

*For those who didn't do this year's Ha-Ha, there were 10 members of the 150-boat Ha-Ha 14 that sailed the entire distance, earning the title of Soul Sailors. We'd like to acknowledge*



# The way of sailing



E - BUILT IN EPOXY | DESIGN BY JUDEL/VROLIJK & CO | MADE FOR SAILORS

**NOMINATED**  
Category: under 10 meter

**320**  
New

**350**  
New

**370**  
New  
e-option

**400**  
New  
e-option

**430**  
e-option

**470e**

**540e**

**630e**

**INNOVATION - SPEED - COMFORT**

- ⚓ Ground breaking interior design
- ⚓ Multiple layout options (see our Individual Cabin Concept)
- ⚓ Modern, award winning performance cruisers

- ⚓ Self-tacking jib engineered into the HanseYachts design
- ⚓ Epoxy hulls (option 37 to 43 ft)
- ⚓ Safe, comfortable, fast & easy to sail

Hanse Yachts US | Ph: 1-410-626-1493 | [dwalsh@hanseyachts.com](mailto:dwalsh@hanseyachts.com)  
Contact your nearest Hanse-Dealer from our Website

[www.hanseyachts.com](http://www.hanseyachts.com)







**HAPPY  
NEW YEAR!**

**HERE'S TO  
FAIR WINDS IN 2008!**

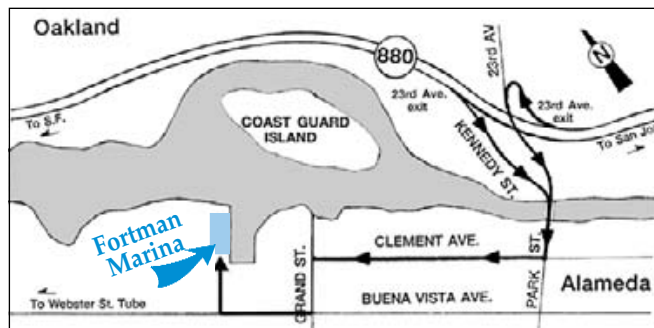

- Sheltered Alameda Location
- Competitive Rates
- Home of the Alameda Yacht Club

1535 Buena Vista Ave., Alameda, California  
(510) 522-9080

For directions and rates go to:  
**www.fortman.com**

## LETTERS

them here. Please note how many of them had 'ordinary' boats as opposed to speedsters. Phil MacFarlane of the San Mateo-based Ericson 35 MK II Sail A Vie; Albert Miller of the Sacramento-based Hunter 36 Delight; Steve Lannen of the Beneteau First 405 Full Quiver; Dan Swett of the Bonita-based Hunter 41 Deliverance; Richard Bernard of the Oceanside-based Valiant 42 Surf Ride; Peter Bruckman of the Kamloops, B.C.-based Beneteau 46 Quickstar; Garland Bell/Jim Taylor of the San Rafael-based Beneteau 47.7 Sooner Magic; Patsy Verhoeven of the Portland-based Gulfstar 50 Talion; Wayne Zittel of the Alameda-based J/120 J/World; and Duncan Hicks of the Incline Village-based Corsair 31 trimaran Flying Fox. Lyman Potts of the Portland-based Royal Passport 43 San Cles would have sailed the entire way, too, had he not heeded a call to tow a boat just a very short distance from the finish of the third leg at Cabo Falso.

### WE APPRECIATE YOUR PROFESSIONALISM

I wanted to take a few minutes to compliment you on your response to the December letter from Jim and Dianne Currah of the British Columbia-based *Ladysmith*. In the letter, titled "I Didn't Know We Could Reserve A Slip There," they expressed their displeasure in the service they received from a representative of the San Diego Harbor Police Department when inquiring about slips at the police dock.

As the Sergeant of the Harbor Police Professional Standards Unit, the unit responsible for investigating Citizen Complaints, I found *Latitude's* response refreshing. You thoroughly and appropriately explained to the Currah's our procedures for accepting complaints, while at the same time educating your readers in these procedures.

Although we don't have any means of contacting the Currah's to follow up on their concerns, I can assure you that we will look into this matter. The Harbor Police take this type of complaint very seriously, and take great measures to ensure that citizen encounters, such as the one described by the Currah's, are an anomaly.

We are aware of the significance of our role within the boating community, and take pride in maintaining excellent relationships with those we serve and protect. We continually look for opportunities to enhance our professional performance, and we appreciate your contribution in this instance.

Thank you again for taking the time to educate your readers as to our complaint procedures. I truly appreciate your professionalism and your service to the San Diego boating community. Keep up the good work.

Sergeant John Reilly  
Professional Standards Unit  
San Diego Harbor Police Department

*Sergeant Reilly — We're happy to help out — and pleased with your response.*

*We've had two previous occasions to contact waterfront law enforcement agencies in Southern California with complaints on behalf of our readers. Once was many years ago with the San Diego Harbor Police, the other time was about five years ago with the Orange County Sheriff's Department. On both occasions, the respective heads of the departments looked into the matters, concluded that their officers could have handled the situations better, and instituted changes. We were very impressed. And rather than becoming angry with us for raising the issues, both departments became friends with us. In fact, after that, officers from the San Diego Harbor Police would stop by our Ha-Ha Kick-Off and Costume Party. They were a big hit, and we hope some officers will visit the party next fall.*



# ULLMAN SAILS

The Sailmaker to Champions!

Get ready for  
spring racing –  
call your Ullman  
loft today!

**THE FASTEST SAILORS CHOOSE  
THE FASTEST SAILS ON THE PLANET**

*R/P 50 Staghound*  
Alec Oberschmidt  
Carbon GPL Main  
and  
Carbon Fiberpath Lt#1 Genoa

PHOTO: BRUCE COOPER US

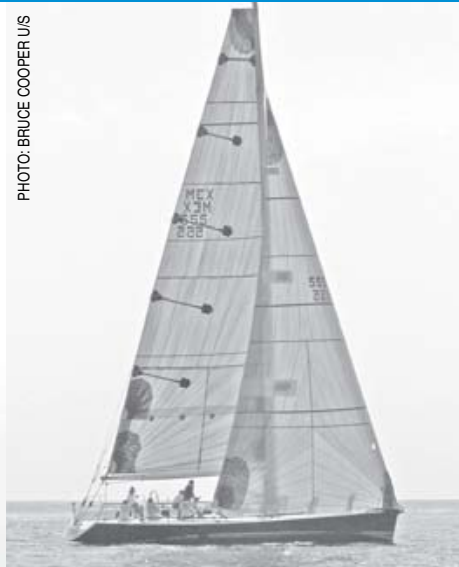

*J/105 Masquerade*  
Thomas Coates  
Airx 700 and  
Superkote 75  
AP Spinnakers

PHOTO: DAVE McBRIDE



*Farr 46 Wasabi*  
Jorge Ripstein  
Carbon GPL "Fat Head" Main  
and Carbon GPL Lt#1 Genoa

PHOTO: STACY McLEAN



**CONTACT AN ULLMAN LOFT OR REP FOR SERVICE AND SALES**

## LOFTS:

Newport Beach  
(714) 432-1860  
2710 S. Crodody Way  
Santa Ana, CA 92704  
Dave Ullman  
Bruce Cooper  
Steve Beck  
Erik Shampain  
One Design  
Charlie Ogletree

San Diego  
(619) 226-1133  
2805 Canon  
San Diego, CA 92106  
Jim Clinton  
Tom Niebergall  
Chuck Skewes

Long Beach  
(562) 598-9441  
6400 Marina Drive #9  
Long Beach, CA  
90803  
Bryan Dair  
Sam Heck

Marina del Rey /  
King Harbor  
Mike George  
(310) 645-0196  
Sam Heck  
(310) 418-9179

Ventura  
(805) 644-9579  
3639 E. Harbor Blvd.  
#111  
Ventura, CA 93001  
Gary Swenson  
Deke Klatt

Santa Barbara  
Ken Kieding  
(805) 965-4538  
Gary Swenson  
(805) 644-9579

Santa Cruz  
Brent Ruhne  
Ruhne Racing  
(831) 295-8290 mobile

Seattle  
Jeff Carson  
Marine Service Center  
(206) 383-8618



Visit our website: [www.ullmansails.com](http://www.ullmansails.com)



# Sailing to Mexico, the South Pacific, Hawaii - or Around the World?

*This is that perfect extra crewmember you have been longing for.*



- It takes ALL the watches, doesn't sleep, drink or argue.
- It doesn't need any electricity.
- It's silent.
- The more it blows the better it works.
- It can also be your EMERGENCY RUDDER.

**And that tough stainless look will let other boats know that you are a serious cruiser.**



See us at the **SEATTLE BOAT SHOW** Concourse #2026

"Sunstone's MONITOR is still going strong for us after 80,000 painless miles and we're looking forward to the next 80,000."

— Tom and Vicky Jackson

Writers for *Cruising World* and other sailing magazines

**BUILT LOCALLY • USED GLOBALLY  
PROVEN FOR DECADES**

GO TO

**www.selfsteer.com**

FACTORY DIRECT

**SCANMAR**  
INTERNATIONAL

432 South 1st St. • Pt. Richmond, CA 94804

Tel: 510 215-2010 • Fax: 510 215-5005

Toll Free: 888 946-3826

email: scanmar@selfsteer.com

## LETTERS

### ↑↓ "LOOK OUT FOR THE WAVE BEHIND YOU!"

The most important and overlooked part of the dinghy disaster scenarios is that you have to look behind you as you go to shore. During our four years of cruising, there were innumerable times when I watched people go to shore from the anchorage and had to scream — "Look out for the wave behind you!" They couldn't hear, of course, so it was pretty entertaining at times.

John Bavin  
Monakewago, Passage 34  
Vancouver, B.C.

John — It's our understanding that one of the first things that Hawaiians — who spend much of their time near the water — teach their children is "never turn your back on the ocean." And for good reason.



LATITUDE / JR

Folks taking dinghies in through the surf should, as you say, keep this in mind.

By the way, while in Banderas Bay last month, we bumped into Jim Hosie, the owner of the dinghy featured in the tremendous dinghy flip at Turtle Bay during the Lucky 13th Ha-Ha. Although Hosie had only started sailing a short time before that event, and took one of the worst dinghy dumps we've

**Jim Hosie not only flipped his dinghy upon landing in Turtle Bay in '06, but has also flipped over the cruising lifestyle.**

ever seen, it hasn't deterred him. He cruised his beautifully maintained Folsom-based Catalina 42 Renaissance as far south as Zihua last year, and is about to continue on to Panama this season.

### ↑↓ I'VE BEEN HOOKED SINCE I SAW THE VIDEOS

In answer to the question that was posed in *Lectronic*, yes, I find Francis Joyon's attempt to break the singlehanded around the world record with his 97-ft trimaran IDEC to be both compelling and riveting. From the moment I saw videos of the huge, red, three-bladed craft scything through the waves, I've been hooked. And since my French is awful, I've been relying on *Lectronic* for updates. So thanks, and keep them coming!

Darryl Tillman  
No Boat Yet  
Aberdeen, Scotland

Darryl — If Joyon continues to the finish at the pace he's been going — which is about 30% faster than Ellen MacArthur's record with her trimaran B&Q Castorama — we think it will very possibly be the greatest singlehanded sailing achievement ever. If we lived in Aberdeen, there's no way we wouldn't make our way over to France to see Joyon finish.

### ↑↓ AND HE'S LEAVING NO CARBON FOOTPRINT

I don't know about anybody else, but I find Francis Joyon's attempt at the singlehanded circumnavigation record with his

# SEAWIND

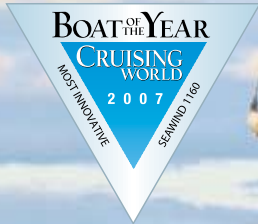

See the Seawind 1160 at the San Diego Boat Show Jan. 3-6

In Northern California



YACHT SALES INC.

314 Tideway Dr., Alameda, CA 94501  
www.helmsyacht.com  
(510) 865-2511

In Southern California  
West Coast Multihulls

1053 Rosecrans, San Diego, CA 92106  
www.westcoastmultihulls.com  
kurt@seawindcats.com  
(619) 571-3513



## SEAWIND 1160

The new Seawind 1160 is turning heads everywhere. This new 38-ft catamaran has just been launched and is proving to be an immediate success. The 1160 combines some of the best features of the Seawind 1000 and 1200 sailing cats. The winner of 2007 *Cruising World* Boat of the Year, the 1160 features an innovative interior layout for easier living arrangements and stunning sailing performance.



*This rare West Coast find needs a new owner that's ready to cruise. Low engine hours and lots of great stuff make this a hot deal! Won't last long so call for more information today.*

Call Kurt at (619) 571-3513 or email: kurt@seawindcats.com

One of the best boat shows in Seawind's 25-year history saw FIVE boats sold at the Annapolis Boat Show! The new 1000 XL and 1160 are proving exceedingly popular with bright, open interiors and outstanding performance. Production is busy so be sure to schedule your build now.



**CORSAIR 28, 2002**  
Like new boat.  
Very well equipped.  
\$79,000



**CORSAIR 24 MKII, 2001**  
Lightly used, very clean.  
\$39,900.



**41' DEHLER DECK SALOON**  
Performance cruiser. German engineering built to an exceptionally high standard. This Dehler is in new condition, electric winches, fly-by-wire inside controls. Full weather and sun enclosures. A rare find and a great buy. \$230,000.



**HC-50-4**  
The next step in the evolution of sailing design and technology brings you the most advanced long distance express cruiser. Born of singlehanded around-the-world experiences, the HC-50 is built to provide a fast, stable, and comfortable passage.



**THE NEW CORSAIR 750**  
Arriving this month - call for demo.  
Corsair 24s from \$31,000 • F-27s from \$46,500  
Corsair 28s from \$72,000



**CORSAIR 36**  
Fast on the water and on the road!  
\$206,000.

## BROKERAGE

Contact Gary Helms at  
(510) 865-2511



# WHALE POINT MARINE & HARDWARE CO.

**A FAMILY OWNED & OPERATED BUSINESS FOR THREE GENERATIONS**  
**MARINE PARTS & ACCESSORIES, PLUS A COMPLETE HARDWARE STORE**

**"DISCOUNT PRICES WITHOUT THE ATTITUDE"**

## 2008 CALENDARS



Many styles available: Woodenboat, Sail, Art, Fishers Book of Days, Light-ho...  
**40% OFF**  
 Qty. Ltd. World of Boating, Bay Area Tide Calendar...

## FORCE 10

**3 Burner Propane Stove**



**FORCE 10**

Model 63351 West \$1339  
**Whale Pt \$1199<sup>00</sup>**  
 Model 63251: 2-burners: West \$1349  
**Whale Pt \$1099<sup>00</sup>**

## WALKER 8'-10' Dinghy

Very affordable. Converts from row boat to sailboat to motorboat. Polypropylene hull. Comes with oars. Sail kit optional.



10' Dinghy: **\$995<sup>00</sup>**  
**8' Special \$699<sup>00</sup>**

## SILVER MARINE Inflatables



Length..Width.....Max ..... Floor .....  
 7'8" ... 4'1" ... 2.7hp .. Roll-up ..... **\$699**  
 8'2" ... 4'3" ... 4hp .. Roll-up ..... **\$799**  
 9'8" ..... 5' ... 9.9hp ... Wood .. **\$1199**

## DOUGLAS GILL "Key West" OS5 Foulweather Gear

Waterproof, red and comfortable



Model..... West ..... **Whale Pt.**  
 Jacket ..... \$239.00 ..... **\$199<sup>00</sup>**  
 Bibs ..... \$179.00 ..... **\$149<sup>00</sup>**

## SEADOG Winch Handle



9" aluminum, locking winch handle.  
**NOW \$19<sup>99</sup>**

## JABSCO TOILET

Manual Model 29090-2000  
**NOW \$149<sup>99</sup>**



Electrical Model 37010-0090  
**NOW \$499<sup>00</sup>**

## PORTABLE HEATER

Indoor safe propane heater.



Mr Heater 4,000-9,000 BTU: **NOW \$99<sup>99</sup>**

**205 Cutting Blvd, Corner of 2nd, Richmond**  
**510-233-1988 • FAX 233-1989**  
 Mon-Sat: 8:30am - 5pm • Sun: 10am - 4pm  
 Email: [whalepoint@acehardware.com](mailto:whalepoint@acehardware.com)

# LETTERS

97-ft IDEC to be very compelling and newsworthy. I also think it's commendable that he's doing it with little or no carbon footprint. Please keep up the regular updates.

Given the world's energy situation, power may very well have to give way — back — to sail. Can you imagine a 20-masted schooner container ship? A catamaran, of course, so the containers don't fall off.

George Backhus  
 Moonshadow, Deerfoot 62

Finike, Turkey/Sausalito/'Home' in Auckland for summer

George — Like you, we're extremely impressed that the top transoceanic and circumnavigating sailors of Brittany are going 'clean' by choice. We don't want to slam the America's Cup any more than it deserves being slammed, but what a waste by comparison. After all, didn't each team make something like 500 sails?

### THE COVER ENTICED ME TO WANT TO GO SAILING

The cover photo for the November issue — the one of the two boys on the bow — was a real delight. They seemed to be having such a blast that it made me want to get out on the water.

Lance Carlson  
 Whatever, MacGregor 26 Power/Sail  
 Oxnard and Ventura Harbor

### WHAT A GREAT NOVEMBER ISSUE COVER!

The kids on the bow of that boat are stoked! I've had some experience teaching kids sailing, and I know the look. For example, just after the TransPac one year, the Andrews 56 *Stealth Chicken* was parked at Hanalei Bay, Kauai, with her delivery crew soaking up the view before setting off on the long sail back to the mainland. I had a class of juniors in 14-footers going for it around a course we'd laid out through the anchorage. Two of the kids on one boat just missed T-boning the *Chicken* when their dink got hit by a puff and they lost rudder control for a few seconds. I was watching from the beach — this was their first solo trip around the course — and still remember the looks on their faces after they'd missed the *Chicken* and made it around the course successfully. It was the look on the kids' faces on the November cover.

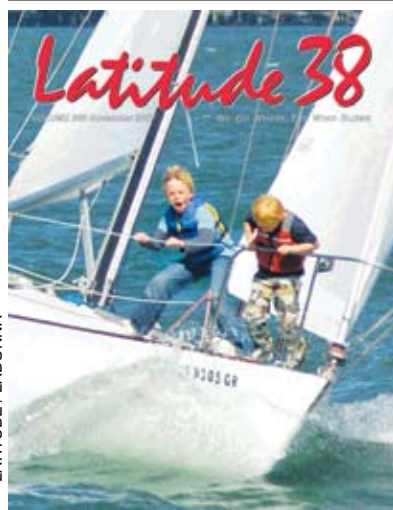

LATITUDE / LADONNA

*The grandparents of the boy on the left were so enamored with this shot, they're blowing it up to poster-size for posterity.*

By the way, your spin on "small craft advisories" went into my boating safety files. I've read and written on the subject, but your take is the best I've seen.

Pat Durkin  
 Waioli, Tartan 34C  
 North Island, Hawaii

Pat — You gotta love the kids! By the way, the photo was



**KKMI**  **Maritime**  
Racing & Rigging

*"I took on several projects myself which gave me the chance to work alongside the KKMI Team. Everyone was competent, friendly, helpful and showed real interest in my project."*



**Bottom Painting Packages**  
where the price we quote  
is the price you pay!

*"The quality of the hull and bottom painting exceeded my expectations."*



**KKMI**  **Maritime**  
Full Service Yard

*"Your team of professionals treat people with respect"*

*"Hats off to everyone; I couldn't be more satisfied"*



**KKMI**  **Maritime**  
Electronics

*"Your team of professionals treat people with respect"*

*"Hats off to everyone; I couldn't be more satisfied"*



**KKMI**  **Maritime**  
Engine Sales & Service

*"Each time the end result exceeds our expectations."*

*"Thanks for the thorough 101 tutorial about my engine."*



*Ask us about discounted Bottom Painting Packages.*

**Keefe Kaplan Maritime, Inc**  
530 West Cutting Blvd.  
Office Ph (510) 235-KKMI  
kkmi.com \* yard@kkmi.com





**FINANCE  
YOUR DREAM  
THROUGH OUR  
WELL-CHARTED  
WATERS**



Seacoast Marine Finance offers more than the best rates, extraordinary expertise and a streamlined loan process. You can rest assured that your application is being handled by professionals who value your privacy and confidentiality. Don't drift into uncharted waters for assistance. Navigate to Seacoast Marine Finance, the premier haven for yacht buyers, dealers and brokers.

*Call for your complimentary quote today.*

Florida toll-free | 877-916-2326  
California toll-free | 800-233-6542  
Seattle | 206-784-7773



[www.seacoastmarinefinance.net](http://www.seacoastmarinefinance.net)

 A division of Seacoast National Bank

# LETTERS

*taken by Latitude's LaDonna Bubak, and we think it's terrific, too.*

## ↑↓SHOW US THE MONEY

Thank you for the outstanding report on the Cosco Busan hitting the Bay Bridge and the resultant oil spill. It was a breath of fresh air after the trash the mainstream media has been putting out ever since. Your article was inclusive, well-researched, and without a hidden agenda. I wish you could give journalism lessons to our local newspapers and TV news reporters.

The first I heard of the incident was from television, and they said they didn't know when or how the pilot got off, where he went, and that he'd been "laying low for 20+ hours." There was a correction a few hours later, but where was the apology to him and his family? If the media, elected politicians, and bureaucrats would have spent as much time on finding a solution as they did searching for blame and someone to sue, I'm sure the problem wouldn't have ended up as bad as it did. And they're still at it. I don't think it has anything to do with saving birds, but is all about bucks and litigation!

Stuart G. Sall  
Red Rover, Hans Christian 34  
Tiburon

*Stuart — Thanks for the compliments. We're glad you liked our coverage, but we certainly wouldn't be as critical of the other media reports. After all, many of them had to write about the event right after it happened and, having been there, we know how hard it can be to get the straight story.*

## ↑↓BUILD A PARASOL FOR THE PLANET?

Once upon a time I sailed to the South Pacific on my Farr 30 *Antipodiste*. While underway, my fresh water consumption was on the order of a few gallons per day. My electricity consumption was way under 500 watts, augmented by a few candles and a pint or so of stove alcohol. I was a happy guy.

The joke, though, was that the half-life of a 'cruising relationship' was 1,000 sea miles or a month in port. This bit



*Charles Warren happily cruised his Farr 30 'Antipodiste' with a very small carbon footprint back in the day.*

of humor, as with most good bits of humor, was based on observation. Another observation was that American girls washed out fast, and few circumnavigated. The only recidivist circumnavigating family I met was from South Africa. Life in a small boat, something like the Old West, seems to be "great for men and dogs, but hell on horses and women."

So what does this have to do with anything? The relevant question is probably something like, what sort of political system would you need to take away the energy-driven comforts Americans love? The next question would be, what sort of world economic order would you need to deny those comforts to those who presently lack them?

The market solution is to rely on prices, but there is no clear connection between the cost of energy production and the costs of climate change. Those costs are poorly understood anyway. The political debate is muddled in shades of authoritarianism between energy taxation — *vive Pigot!* — and a new post-Mao Cultural Revolution. Al Gore, Prince Charles, and



# Baja Sur

Jacques Cousteau considered the Sea of Cortés the world's largest aquarium. Come view it from within.



The Sea of Cortés is not only winter home to the grey whales, it has more marlin than any area of the world as well as thousands of other colorful creatures that are *not* to be observed from afar. So, to get an up-close view, and to experience the adventure of this unique environment, just dock your vessel at any one of the four superb marinas in La Paz and, at your leisure, wander the streets and byways of this picturesque town, cruise to the fishing grounds, or explore a quiet island, cove or inlet. Then as Mr. Cousteau preferred, jump right into the aquarium. You'll never feel so alive.

For more information visit:  
[marinacostabaja.com](http://marinacostabaja.com); [marinadelapaz.com](http://marinadelapaz.com);  
[marinapalmira.com](http://marinapalmira.com); [clubcantamar.com](http://clubcantamar.com)



Come Explore the Richness of Baja Sur.

# Baja California Sur

[mybajasur.com](http://mybajasur.com)

1 877 MY BAJA SUR



Visit  
**Downwind Marine**  
 at the  
**San Diego Boat Show**  
**January 3-6**

with



Pick up a FREE CD, Catalog and Cruising Guide

Or visit our website for

Expanded Worldwide Service • Reduced Market Beating Prices

Rapidly Growing Inventory



West Coast sailors have long known of  
 Downwind Marine's  
 extensive experience and great value.

- Save with every 'click'.
- We specialize in special orders.
- Expert help when you need it.
- TRY IT, it won't cost you, it will save you!



Open: M-F 8-5 • Sat. 9-5

(619) 224-2733 • TOLL FREE (866) 289-0242

[www.downwindmarine.com](http://www.downwindmarine.com)

2804 Cañon St., San Diego, CA • email: [info@downwindmarine.com](mailto:info@downwindmarine.com)  
 CRUISERS' NET, Ch. 68, from 8:30 am weekdays: WHX369

*Boating is  
 already Fun –  
 We make it more  
 Affordable©*

## LETTERS

like-minded wealthy visionaries can buy indulgences — at least for awhile.

Perhaps we need to celebrate Sputnik's 50th anniversary with a new commitment to space exploration and exploitation. First, if we're only going to do experimentation with our atmosphere, the only breathable one in our solar system, maybe we need to provide a bolt-hole for at least a few if it goes wrong. Second, once out of the earth's gravity, building large structures may take time, but not a lot of materials or energy. In a century, we could probably build a respectably sized parasol for our planet. Maybe it could also generate power. Maybe we could find a way to use that to reduce our dependence on carbon-based fuels, of which we have no more than a few centuries' supply of anyway.

Charles Warren  
 San Francisco

*Charles — There may be "no clear connection between the cost of energy production and the costs of climate change," but market forces — i.e. higher prices — could certainly "take away the energy-driven comforts Americans love." For example, if the price of fuel at the pump ever reached that of bottled water at 7-Eleven, Americans would be doing a hell of a lot less driving — or would at least drive cars that got a lot better gas mileage. As we Americans are already sending \$1 billion a day to Arab countries for oil, it behooves us to reduce our consumption — and build lots of nuke plants — now rather than later.*

*As for American girls, we see a growth in the extremes. Unfortunately — for them — there seem to be more Paris Hilton wannabee princesses than ever. Fortunately, there seem to be a lot more adventuresses, too. Speaking as a guy, there are few qualities we find more attractive in a woman than an adventuresome spirit.*

### ↑↓ BLUEBIRD, TAKE ME ON YOUR WING

We're pleased to announce the launching, on American Lake, of our 28-ft sailing trimaran *Bluebird*. She has 16'6" of beam



COURTESY BLUEBIRD

*She's new, she's blue, and she's headed to Mexico.*

with her amas extended, and 9'3" with them retracted. She draws 12 inches, weighs approximately 1,820 pounds, has a sail area of 330 sq. feet, and is powered by an 8 hp Honda outboard. She travels to weather at 55 mph on a 40-ft King trailer, and will soon be voyaging at speed to Banderas Bay, Mexico. She was designed by Jack Taylor and built by Synergy Systems Co. in Lakewood, Washington in '06 and '07.

Jack and Muriel Taylor  
*Bluebird*, 28-ft tri  
 Lakewood, Washington

### ↑↓ DO THE RIGHT THING FOR YOUR CHILD

I'm writing in response to the December letter from Michael Walsiewski, who is seeking to gain approval from the court system to raise a child on a boat. Having gone through the same process myself as a father and single parent, I can provide Michael with some advice.

# BIG or small, we do it all



at...

## ANDERSON'S BOAT YARD

*The Captain's Choice Since 1968*

### Call Now to Reserve Space For:

- Sprayed Racing Bottoms
- Complete Rigging & Wood Shops
- Electrical Installation & Repairs
- Custom Topside Paint Jobs
- Custom Metal Fabrication
- Engine Service and Repower

400 HARBOR DRIVE • SAUSALITO, CA 94965

**(415) 332-5432 • (800) 310-5432**

Fax: (415) 332-8136

**[andersonsboat@pacbell.net](mailto:andersonsboat@pacbell.net) • [www.andersonsboatyard.net](http://www.andersonsboatyard.net)**

 **Interlux.**  
yachtpaint.com



## Clean Boat Bottoms Today... Cleaner Bays and Waters Tomorrow.



Help keep our bays and waters clean for the boaters of tomorrow.

Introducing Sea Hawk's  
New Copper-Free  
"GREEN" Antifouling:  
Mission Bay



Available at your local boatyard or contact us:



Family Owned &  
Operated since 1978

PREMIUM YACHT FINISHES

NEW NAUTICAL COATINGS, INC.

800.528.0997 U.S.A. Only • 727.523.8053 International

contactus@seahawkpaints.com • www.SeaHawkPaints.com

## LETTERS

As a single father you already have points against you, for we are still in the dark ages when it comes to an equal "shared" custody for fathers, and worse, "reasonable" visitation. A father is profiled as the working parent who has less time to be with his children.

Although I see the beginnings of change, the courts lean toward the traditional motherly role. And I agree with the courts — in the early stages of a child's development. However, from ages six through 18, especially for a boy raised by his father — as in my case — a boy needs the male bonding more than the nurturing from his mother. A boy will have it one way or another, for a male child will seek out alpha males as leaders through sports, gangs or the military. I was more fortunate than many as, for reasons that were apparent to the court at the time, I was granted primary custody during my son's developmental years.

I was able to take my eight-year-old son with me to Mexico to spend a year sailing the Sea of Cortez on my 28-ft boat. I was his teacher and home-schooled him along the way. We sent emails to the third grade class that he left behind. He was a hero to his classmates when he returned the next year.

Being with my son 24/7 was an incredible experience, something that is beyond a court's understanding. They do not — and cannot — possibly know what it's like to sail with your son. With my case it was argued as being dangerous. Living in Los Angeles is dangerous! But I was allowed to leave with my son as long as there was communication with his mother on a regular basis. I completely agreed with this requirement, although it was a daunting task to say the least.

It was a miracle that I was able to convince the court to allow me to do this, for they were unaware of the countless positive experiences it gives a child of eight. Being able to identify the stars and have them guide us, being able to meet kids on boats from different backgrounds, and having his father as a teacher, mentor and friend was the most incredible experience that he and I have ever shared.

I don't expect Michael to be another Sterling Hayden and run off with his child, nor do I give him much of a chance of talking his ex-wife into letting his son sail to another country with him, but I do offer this as motivation to do more than the ordinary. Don't let what I have seen in the past happen to you. If all you are doing is living on a boat and not taking it out with your child, you are missing out on the best moments the two of you can share. Here in Southern California, we have the Channel Islands. In San Francisco Bay you have the Delta, Angel Island or just pulling up to the docks of restaurants. If your boat is a sailboat, introduce your child to racing. Do something with your boat that involves both of you, or you might as well live in the corner of a small, dark, cold and cramped garage — for that's what it will seem like to a child who wants and needs an adventure with his parent. If your boat isn't seaworthy, join an active yacht club, one that sponsors youth programs. Or just purchase two Sabots and teach him the basic sailing skills. There isn't a sailor alive who doesn't remember his first times and how great they were.

I remember taking Zach out on our sailboat and catching a fish while sailing to Catalina. I'm not a fisherman, but tried to have a similar father/son experience with my son as my dad had with me. We caught a huge fish — I think it was a yellowtail — and, not knowing what to do next, I left it flopping around in the cockpit of our boat. Zach was four, and asked the normal questions. "When is he going to die? Will we eat him? Is he an old fish?" Zach and I decided to take the hook out and throw the fish back into the sea. After we did, he looked up at me and said, "I feel better about letting him go. Is that



# HAULOUTS 20' to 80'

**HAULOUTS ON SHORT NOTICE...CALL US!**



**NORTHERN LIGHTS**

**GENERATOR SALES & SERVICE**

**WUGGER**

**MARINE ENGINES SALES & SERVICE**

**YOUR NEW FULL SERVICE VOLVO PENTA DEALER IN THE BAY AREA**

**PETTIT**  
marine paint

## **FULL SERVICE BOATYARD:**

- ✓ COMPLETE PROPELLER SHOP
- ✓ ELECTRICAL REPAIR & INSTALLATION
- ✓ FIBERGLASS BLISTER WORK
- ✓ LPU PAINTING
- ✓ COMPLETE MACHINE SHOP
- ✓ SHIPWRIGHTS - CAULKING & CARPENTRY
- ✓ GAS & DIESEL ENGINE SERVICE
- ✓ MAST & RIGGING REPAIR
- ✓ SANDBLASTING & EPOXY COATINGS
- ✓ FIBERGLASS & GELCOAT REPAIRS
- ✓ USCG CERT. WELDERS - STEEL/ALUMINUM
- ✓ INSURANCE WORK WELCOME

**88-TON TRAVELIFT HANDLES UP TO 23' BEAM!**

**Online reservations now available at [www.baymarineboatworks.com](http://www.baymarineboatworks.com)**



**1-800-900-6646**  
(510) 237-0140 • Fax: (510) 237-2253

**STEVE TAFT, MANAGER**

**310 WEST CUTTING BLVD. • POINT RICHMOND, CA 94804**





# LETTERS

**ATTENTION  
CRUISERS!  
MEXICAN  
LIABILITY  
INSURANCE  
ONLINE**

**MARINERS**  
GENERAL INSURANCE GROUP

Now with six offices offering  
you local insurance service  
and global insurance  
coverage.

**SEATTLE**

Joe Cable  
(800) 823-2798  
(206) 281-8144  
Fax (206) 281-8036

**NO. CALIFORNIA**

(800) 853-6504  
(650) 373-0595  
Fax (650) 548-1585  
email: boomeins@aol.com  
Lic. # 0A99058

**L.A./ORANGE COUNTY**

Craig Chamberlain  
(800) 992-4443 • (949) 642-5174  
Fax (949) 642-0252  
Lic. # 0D36887

**SAN DIEGO**

Henry Medina  
(800) 639-0002  
Fax (619) 226-6410  
Lic. # 0A96346

**BRADENTON, FLORIDA**

Jerry Norman  
(800) 914-9928  
Lic. # E051940

**New!**  
**PUERTO VALLARTA**  
(949) 642-5174

*We insure racers and cruisers all over  
the world with prompt, reliable service.*

**www.marinersinsurance.com**

- **Sail & Power**
- **Fishing Boats**
- **Charter Boats**
- **Liveaboards**
- **Marine Businesses**
- **Tugboats**
- **Cargo**
- **Offshore Cruising**



**It's a Mariner's Fact:**

*Failure to maintain a proper lookout by sight and hearing violates the Navigation rules, is a major cause of collision at sea, and reduces the safety of all boats in the area.*

okay?" I hugged him and told him, "Yeah." In any situation, both you and your child can learn new things together.

My advice is not to think about what the courts ask of you at this point. Do the steps to convince them that this will benefit your relationship and the development for your child. Persevere. Go outside the approved boundaries, for the right motivations can do more than the ones you are given. In the end, if you do the right thing for the child, they will see that and grant you the visitation you need to provide the lifestyle you'd like your child to have.

Zach is now 18 and attending UC Berkeley on a scholarship. He's not on drugs, with a gang, or living at home trying to decide what to do with his life. I know the year we spent sailing together — and all the activities we did together in between — made a lasting positive impression and influenced him toward the direction he is now sailing on his own.

Jim Barden

Ann Marie

Still In The Sea of Cortez

*Jim — Thanks for the observations.*

*We got divorced when our kids were six and four. It was not a good thing, because kids desperately need both a stable environment and ongoing male and female influences. But the kids' mother and we made the best of it. She was in charge of nurturing, while we were in charge of adventuring. With the support of their mother, we dragged those kids on sailing adventures all over the world. And now, 20 years later, we relive them with laughter frequently, as they were some of the best times of our lives.*

**MUCH TO LEARN OUTSIDE THESE HALLOWED HALLS**

Thanks for turning a positive spotlight on the kids that were part of the recent Baja Ha-Ha. Emily Applewhite of



LATITUDE / RICHARD

*Mary Alice, seen here in the South Pacific, knows all about the educational benefits of cruising.*

Emily, crew on *Volcano* and one of our students at Woodward Middle School, was a participant, and came back with changed ideas and attitudes about what's important in life and her world. There is lots of learning to be taken advantage of outside our hallowed halls.

My husband Brian and I are avid sailors, and have done a circumnavigation aboard *Shibui*, our Norseman 447. You can imagine my excitement at seeing our student and classmate in the pages of *Latitude* 38. Never mind that Woodward Middle School has been in national publications. Being mentioned in *Latitude* was far more exciting. Life is about balance!

Mary Alice O'Neill  
Principal, Woodward Middle School  
*Shibui*, Norseman 447  
Bainbridge Island, WA



# WOW!

There is a new way to enjoy a Beneteau

# HOW?

You can do it with Beneteau Fractional Yachting

# NOW.

Visit [beneteaufractional.com](http://beneteaufractional.com) or contact your local dealer



**BENETEAU**

**FRACTIONAL  
YACHTING**





“Looking Beyond Tomorrow”

## FACTORY DIRECT!!!

**Seconds, Discontinued  
& Overstocked Items**

Visit our Showroom  
Monday-Friday 10:00am - 2:00pm

**Precision Lighting Showroom**

**3635 Standish Avenue, Santa Rosa**  
Just two blocks off Hwy. 101 – Todd Rd. Exit

- Gift items: Desktop/bar globes, knives, porthole clocks, barometers, mirrors, ship bells
- 12 & 24 Volt Light Fixtures
- 12 & 24 Volt Light Bulbs and adapters
- LED Chip-Tech Lamps & Rope Lighting
- Portholes and Deadlights
- Anchoring & Docking accessories
- Cabinet, Plumbing & Restoration hardware
- Sailboat hardware
- Plumbing accessories

*Let us help you with  
energy savers and lighting ideas*

**WWW.ABIMARINE.COM**

**800•422•1301**

**707•585•6210**

## LETTERS

*Mary Alice — Thanks for the very kind words and the observation. And don't think that we don't remember meeting you and Brian — what was it, 12 years ago? — somewhere in Tonga or Fiji. In fact, check out the accompanying photo of you and Brian that we managed to pull out of the archives.*

### ↑↓IMAGINE USCG SATISFACTION SURVEYS

What an enjoyable experience it is to be boarded by the Mexican Navy! They are always very courteous, concerned about not leaving footprints on our boats, and love to practice their minimal English. Best of all, they give mariners a satisfaction survey to complete before they push off and say *adios*. Imagine if the U.S. Coast Guard handed out satisfaction surveys at the end of their safety inspections.

Jerry Jordan  
Manu Wai, Cape George 38  
Seattle / Mazatlan

*Jerry — We think it would be a great idea — both for the public and the U.S. Coast Guard — if they did pass out satisfaction surveys.*

*As we've mentioned before, Mexico really seems to be getting into the customer satisfaction business. Just before we flew out of Puerto Vallarta in early December, a clean-cut, friendly young Mexican man who was fluent in English asked if we'd let him conduct a survey about the airport. He was so nice that we couldn't refuse. It was a detailed survey, and he took care to record our responses accurately. As such, it comes as no surprise that the Puerto Vallarta Airport — which has greatly expanded recently to handle the huge upswing in business — is terrific. The lines were all short and quick, the airport staff were friendly and professional, and the whole facility — including the restrooms — sparkled.*

### ↑↓I'M TERRIFIED TO GO TO UNFAMILIAR MARINAS

I'm writing in hopes of finding the answer to whether or not there is a law that requires a marina/boatyard or a mariner who damages someone's boat to, at a minimum, supply the name of their insurance carrier. I've never needed to utilize my own insurance, but it seems to me that the law, regarding property damage, would be similar to car insurance. As motorists, we are required by law to provide insurance information in the event of an accident, as well as file an accident report with the DMV.

Here's where I'm going with this: Last summer a boatyard in the East Bay relocated the 1947 Lyle Hess-designed classic *Lady Elizabeth*, which a friend of mine had recently purchased, to the shallow end of their fuel dock. The *Lady E* was negligently grounded, which caused the keel to be torn off — something that supposedly went unnoticed by all the marina personnel. My friend tells me that the keel is still sitting there, in just six feet of water, posing a serious hazard, all because the dockmaster refuses to cooperate with my friend in resolving the matter. I honestly don't know what he could be thinking — other than if he waits long enough, the whole nightmare will just disappear. The boatyard has refused all communication with my friend, including her numerous registered letters. As a result, she feels that she has no other recourse than to contact the marina's insurance company directly. The problem is, they won't tell her the name of the insurance company.

Surely, there must exist some legal agency to prevent such ridiculous and dangerous matters from going without resolution. Her boat could sink without the keel attached — and she could be on it. Does it take a death in order to get someone's



Paradise Village™  
MARINA & YACHT CLUB

# *Paradise Village Marina* *...Treasure of the Gold Coast*



Share with us our Successful combination:  
• *Service* • *Security* • *Location*

## Services:

- Electrical service, 110/30amps, 220/50 amps and 3 phase 100amps
- Potable water
- Cable TV
- Garbage collection
- Pump-out Station
- Fire fighting boat protection
- 24 hrs. Security.
- Computerized gate access

## Additional services:

- Vallarta Yacht Club
- Special area for marina guests
- Restrooms
- Showers
- Lockers
- Pool and Jacuzzi
- Free access to all the facilities of our 5 star hotel
- White sand beach
- Dive tank refilled
- Propane refill
- Launch ramp



CONTACT US:  
marina@paradisevillagegroup.com  
Phone & fax from U.S. 011-52-322-22-66728  
[www.paradisevillage.com](http://www.paradisevillage.com)



GPS Coordinates 105 17.9 W 20 41.2 N CHANNEL 16



*multihulls*  
*classic sails*  
*offshore spec*  
**one design**

**NEILPRYDESAILS**



San Francisco Bay Area  
Jim Leech 415 827-1177  
Jack D. Scullion 510 919-0001

Monterey Bay Area  
Larsen Sails 800 347-6817

**Sail outside the box**  
[www.neilprydesails.com](http://www.neilprydesails.com)

## LETTERS

attention to something like this?

In all my years of boating, this is a horror story unlike I could ever imagine, and has left me, along with all of my 'solo' female boating friends, terrified of going near unfamiliar marinas — especially in the Bay Area — ever again.

I have a much smaller boat than *Lady Elizabeth*, and fortunately, my *Harry P.* is resting safe in my backyard — and will remain there until I completely familiarize myself with boating insurance law.

Mary C. Furch  
*Harry P.*, West Wight Potter 15  
San Diego

*Mary — If there's a collision between boats in which there is damage of more than something like \$500, both parties are required to file a report with Cal Boating. But since even the smallest boat nick is likely to cause \$500 in damages, you can imagine how seldom mariners comply with that law. But more to your question, we're not sure you have to provide the other party in a boat accident with insurance information, as boats, unlike cars, aren't required to have insurance.*

*When there's a dispute such as your friend apparently has with the boatyard, and the boatyard doesn't respond, the normal course of action would be to consult a lawyer. If the lawyer thought your friend had a good cause for action, he/she would write the boatyard demanding some sort of remedy. If the boatyard didn't agree or respond within a reasonable amount of time, the lawyer — if he/she felt it was worth his/her time — would file a lawsuit on her behalf. If the damages weren't so great, the matter could be taken to Small Claims Court. Having said this, it's rarely in anybody's interest to go to court, as only the lawyers and government employees usually win.*

*In addition, the potential problem we see with your friend's case is that a boat's keel shouldn't fall off just because it hits bottom — unless the boatyard staff hit the bottom with her at about 25 knots. As such, a court might find that the condition of your friend's boat was the cause for the keel to fall off, in which case she might have to pay the cost of removing the keel from the boatyard, back berth fees, the boatyard's legal fees — and still have a disabled boat.*

*In any event, we can't imagine why this would make you and your friends "terrified of going near unfamiliar marinas." If we may be frank, you and your friends should be more terrified of 60-year-old wooden boats, as they require a lot of time and money to maintain.*

### ↑↓ THE PRESIDIO YC COULD BE AN ASSET TO THE PARK

I read the letter from Jeffrey Keeton regarding Horseshoe Cove with great interest and a little sadness. In '74, while on active duty in the Army, I was assigned to duty at Fort Baker. Within a month I owned a Columbia 26 Mk1, and was a member of the Presidio YC. Even though I had just completed a four-year assignment in Hawaii, where I sailed a Cal 20, which wasn't bad duty, I felt I'd died and gone to heaven after arriving at Ft. Baker and San Francisco Bay. I subsequently kept my Hawkfarm *Courageous* and One-Tonner *Rolling Stone* at the Presidio YC.

A common misconception, which *Latitude* expressed, is that the Presidio YC and the Travis Marina at Ft. Baker are "Treasury-draining boondoggles." The truth is that they've always paid their way via member's dues and, in fact, provided a considerable positive cash flow to support the Morale activities of the Army and Air Force. The docks and so on were built and paid for by members. In addition, a typical monthly workday would find 30-40 members building fingers, pound-



Discover

# Brisbane Marina

## GREAT LOCATION!

Just ten minutes from downtown San Francisco and close to Central Bay sailing.

## GREAT RATES!

\$5.90/foot!

## GREAT FACILITIES!

All concrete docks.  
Newly constructed boater restrooms  
and laundry room.

## KAYAK STORAGE!

\$25 per month.



DRIVING NORTH OR SOUTH ON HWY 101,  
TAKE THE SIERRA POINT PARKWAY EXIT AND  
FOLLOW THE SIGNS TO THE MARINA



400 Sierra Point Parkway, Brisbane, CA 94005

(650) 583-6975

[www.ci.brisbane.ca.us](http://www.ci.brisbane.ca.us) · [harbormaster@ci.brisbane.ca.us](mailto:harbormaster@ci.brisbane.ca.us)

Open 7 days a week: Monday - Saturday 8am-5pm, Sunday 8am-4:30pm





# Don't Let This Happen To You!

## Marine AIS Receivers

Give your navigation software or chartplotter  
the power to see shipping traffic.

Prices start  
from only  
**\$189!**



**Why Leave Your –  
And Your Family And Crew's –  
Safety to Chance?**

Commercial ships now use AIS transponders.  
Map nearby ships with supported  
navigation software and chartplotters  
connected to one of our low cost AIS Receivers.

For more information visit:

**www.MiltechMarine.com**

Or call us at:

**Milltech Marine  
425-818-5246**

## LETTERS

ing nails and picking up trash on the beach. The one great advantage, of course, was that the Army owned the land and buildings.

The Presidio YC is a 300+ member club that actively participates in all boating activities in the Bay, including sponsoring YRA races, PICYA activities, the normal inter-yacht club cruises and so on. The membership is less now, but the activities are the same. The only difference between members of Presidio YC and other clubs is that, in addition to a common sailing bond, we also have the common bond of military service.

By the time the Army decided to leave the Bay Area, I was long retired and cruising aboard *Rolling Stone* with my wife, Dolores, and we ultimately ended up in Scotland. I recognize that all the sailing, racing and cruising I was able to do over the past 40 years was a result of the military-supported boating activities at Ft. Monmouth, New Jersey, Hickham AFB, Hawaii, and the Presidio YC at Ft. Baker. I don't think anyone thinks of military service as much of a "boondoggle" these days.

I agree with Jeffrey that Horseshoe Cove is a poor location for a recreational boating facility for Travis personnel because it's such a long drive. And I'm afraid that the nail in the coffin was driven long ago when the Golden Gate National Recreation Area and its advisory panel decided not to house a "military yacht club" in Horseshoe Cove. I feel sad about that, as many, many people put a lot of sweat into it and continue to do so. The Presidio YC could be an asset to the park.

As for me, we moved on to the Point San Pablo YC in Point Richmond, which is a great and fun club that owns its land. We sold *Rolling Stone* in Scotland, and she now resides in Germany. I still read *Latitude* every month, even though our latest boat, *Dolores E*, is a converted salmon troller. I periodically help Hans from Scanmar sell Monitor Windvanes at various boatshows and bum rides on friend's sailboats.

Robby Robinson  
Sergeant Major, U.S. Army (ret.)  
Mill Valley

*Robby — We agree with you, it makes a lot of sense for the Travis sailing program to be located some place closer to Travis Air Force Base. However, that doesn't mean it makes any sense for the military to give up a facility that their other members could use. And with a Bay dying for berths close to the Central Bay, what's the sense in encouraging the elimination of 70 berths?*

*It's true that the best time to make sure the Horseshoe Cove marina and Presidio YC wouldn't be lost was years ago during negotiations with the National Park folks. But as an irregular veteran of the Telegraph Avenue Army while a student at Berkeley in the '60s, the one thing we learned is that it's not over until it's over. And even then, it's still not over. The war for Peoples' Park, for instance, has been going on for what? 40 years? And it still — for better or worse — hasn't been lost.*

### ↑↓WE CAN'T WAIT TO SAY "WE TOLD YOU SO"

I would not agree with Jeff Keeton's portrayal of Horseshoe Cove as being as "gloomy as a foggy and windy February afternoon in the Cove," since any day in the Cove is better than a sunny day across the Bay. It isn't that the marina wasn't a good fit for the military, it's that the military once again fell victim to local politics. The Park Service snatched the marina out from under the Air Force, forcing the Air Force into a rental agreement. Then along comes a wolf in sheep's clothing, big business under the guise of a convention center, and bye-bye

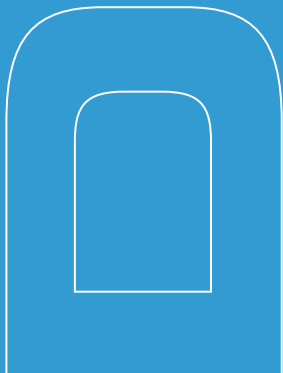
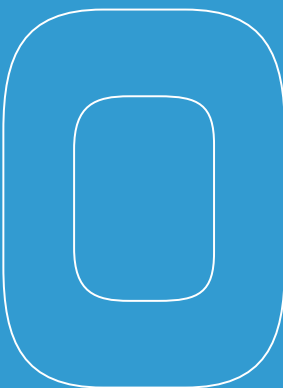
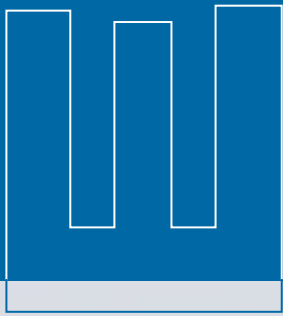

Photo courtesy of Sailing World

## Four NOODs. Four Victories.

Doyle powered Beneteau 36.7's have won their class in the 2007 San Diego, Annapolis, Detroit, and Chicago NOODs. The secret? Doyle offshore one-design clients are finding that not only are their sails faster than the competition but that the Doyle Set Up and Tuning Guides help them go faster across a wide range of conditions. You can go faster in 2008, too—take the first step by contacting your local Doyle loft.

### Doyle San Francisco

Bill Colombo & Rusty Canada

2035 Clement Avenue

Alameda, CA 94501

Tel: 510-523-9411

E-mail: [sanfrancisco@doylesails.com](mailto:sanfrancisco@doylesails.com)

[www.doylesails.com](http://www.doylesails.com)



1-800-94-DOYLE

BETTER ENGINEERED SAILS



## OUR STAR ATTRACTIONS



50' 1987 SANTA CRUZ



37' 1999 PAC SEACRAFT



37' 1985 AMAZON

PRESENTING  
MIAA  
January

1989 48' HANS CHRISTIAN

### SAIL

- 1985 44' Sirena
- 1999 43' Shannon
- 1981 35' Hinterhoeller
- 1985 33' Nauticat

Yachts  
McGrath



www.McGrathYachts.com  
41 Liberty Ship Way Sausalito 415.331.5020

### POWER

- 1988 73' Philbrook Pilothouse
- 2004 53' Barge
- 1984 49' Kha Shing
- 1998 48' Navigator
- 1996 46' Viking
- 1989 45' Californian
- 1979 44' Marine Trader
- 2006 44' Sea Ray
- 1984 43' Bestway
- 1987 43' Kha Shing
- 1984 40' Kha Shing
- 2000 36' Heritage
- 1980 36' Albin
- 2005 36' Meridian
- 1980 34' Mainship
- 2006 34' Meridian
- 1972 34' CHB
- 1990 31' Tiara
- 1997 31' Albin
- 1982 31' Sea Horse
- 2000 30' Pursuit
- 2000 28' Albin
- 1987 28' Faltline
- 1999 27' Sea Sport
- 2000 27' Sea Sport
- 2000 27' Sea Ray

## LETTERS

military, which has controlled the area since 1866.

I take exception to your portrayal that the Travis Marina is nothing more than a military boondoggle, draining the U.S. Treasury, since it is so obvious that you have no idea about the history of the Bay Area. The Army purchased the Fort Baker area in 1866 because the United States was very concerned with protecting the strategically important Golden Gate strait from potential enemies. The intention at the time was to build a brick fortification just like the one at Fort Point, but by the time the foundation was completed, technology had bypassed a fort, and the military instead developed the area as batteries in the 1870s to 1890s. By controlling land on each side of the strait, the Army possessed unique advantages in defending San Francisco Bay.

World War II brought antisubmarine minefields and nets, as well as antiaircraft guns being added to the batteries. Fort Baker became the depot for the underwater minefields. The wharf that is deteriorating in front of the Presidio YC was built as a submarine mine wharf to accommodate the large mine-planter ships. In 1943, the marine repair shop was built to repair all boats, and had three boat launchways, one of which still survives in front of the Presidio YC. In order to protect the boatyard, the Army built the existing breakwater. During the 1950s and 1960s, Horseshoe Cove was the home of the 561st Port Construction Engineer Company, which was the Army's version of the Sea Bees, and constructed and/or repaired ports. They also conducted rescues, aided in civil emergencies, inspected piers, welded deteriorating ship hulls from underwater, and cleared ship wrecks. In 1972, legislation created the Golden Gate National Recreation Area that included Fort Baker within it. Since the defense program was reduced in size, the Army felt no need to maintain their presence in San Francisco and gave over their Bay Area property to the National Park Service in 2002. So much for your boondoggle theory.

The Air Force was given the use of the marine repair shop in 1959 as an MWR facility for all branches of the military, and allowed the Presidio YC to set up their club within the confines of the marina. Civilian contractors have run the marina from the beginning. As for being "Treasury-draining," the marina is a self-sustaining entity. It has been the leading income-producing program of the Travis Air Force Base Outdoor Recreation and Services for the past two years, making more income than all Travis services combined. In other words, the Travis Marina and the Travis Sailing Academy have been the sustaining forces behind keeping the Travis Outdoor Recreation and Services in the black for as long as I can remember. We are not layabouts on the military dole.

I agree that the cove is a rare and unique site. Under current plans, it will no longer be a marina, as mooring balls do not a marina make. Seventy, plus or minus, boats — both power and sail — will be displaced by the plans of the "folks or organizations with greater vision and resources." So, no sir, we don't agree with you and your staff who are so obviously on the side of the National Park Service allowing big business onto a historical site and an MWR facility the minute they were ceded the property.

Is it any wonder that those of us at the marina, who have dedicated so much of ourselves, our time, and our resources to further the recreation of those fighting in foreign lands, are so against the convention center, and look at Louie with jaded eyes? Is it any wonder that the military keeps withdrawing from the Bay Area, with the political maneuvering and anti-military stance we see everyday, which shows so clearly not only in your attitude, but in the attitude of our own



# ALAMEDA MARINA

1815 Clement Ave., Alameda ~ (510) 521-1133  
www.alamedamarina.net



## A MARINA TO SUIT ALL YOUR NEEDS

- 530 Wet Berths 22-40 ft
- End Ties 40-70 ft
- Dry Storage – Trailer Boats
- RV & Camper Storage
- **Easy Access by Car or Boat**



Our tenants include some of the most respected names in the sailing industry, representing a full spectrum of services. Visit us today.

<p><b>Doyle Sailmakers</b> 2035 Clement, Bldg. 32C <b>(510) 523-9411</b> <i>Better Engineered Sails</i></p>	<p><b>L.T.D. Marine Electrical</b> 2035-B Clement, Bldg. 32B <b>(510) 523-2521</b> www.ltdmarine.com</p>
<p><b>Eskelund Marine Volvo Service</b> 1913 Clement, Bldg. 13 at Pier 2 <b>(510) 523-7670</b> <i>Volvo Penta specialist since 1980</i></p>	<p><b>Reliable Marine Electronics</b> 1925 Lafayette <b>(510) 864-7141</b> www.reliablemarine.com</p>
<p><b>Hogin Sails</b> 1801-D Clement, Bldg. 28A <b>(510) 523-4388</b> www.hoginsails.com</p>	<p><b>Sal's Inflatable Services, Inc.</b> 1914 Stanford <b>(510) 522-1824</b> <i>Your Survival is Our Business</i></p>
<p><b>The Japan Woodworker</b> 1731 Clement <b>(510) 521-1810</b> www.japanwoodworker.com</p>	<p><b>Svendsen's Boat Works/Chandlery/Metal Works</b> 1851 Clement <b>(510) 522-2886</b> www.svendsens.com</p>
<p><b>HF Radio On Board</b> 1813 Clement, Bldg. 24 <b>(510) 814-8888</b> www.hfradio.com</p>	<p><b>Waypoint</b> 1813 Clement, Bldg. 24 <b>(510) 769-1547</b> www.waypoints.com</p>



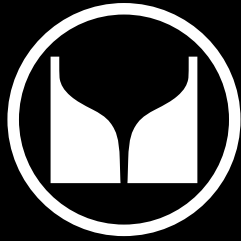

# SVENDSEN'S MARINE



## True North Deluxe High Performance Heater



- 2 Speed Fan
- 600/900/1500 Watts
- Thermostat Control
- Antifreeze Setting
- Durable finish
- 5-year warranty

LIST PRICE: \$75.15

SALE PRICE:

**\$41.95**



## 25-foot 30-amp Shore Power Cord Set (50-foot also available)

LIST PRICE: \$75.00

SALE PRICE:

**\$45.00**

## mcmurdo

### Fastfind Plus 406 P1b with built-in GPS



- Built-in GPS receiver
- Global alert to Cospas-Sarsat satellites
- 406MHz transmitter
- 121.5 MHz homing frequency
- Weighs just 11 oz.

LIST PRICE: \$788.00

SALE PRICE:

**\$529.00**

PRICES VALID THROUGH JANUARY 31, 2008

**LOCATED IN THE ALAMEDA MARINA  
1851 Clement Avenue, Alameda**

CHANDLERY: **510.521.8454** • BOAT YARD: **510.522.2886**

## LETTERS

harbormaster? This rare and unique marina site is available to folks and organizations right now. However, the convention center's "greater vision and resources" have already changed our environment for the worse. How much worse is yet to be seen. I will take great delight in saying I told you so when you pay to enter Fort Baker through locked gates that do not currently exist. The Travis Sailing Academy will be sitting elsewhere and we will have smug smiles on our faces.

Phyllis Burns Keeton, Sailing Master  
Travis Sailing Academy  
Travis Marina, Horseshoe Cove  
Fort Baker

*Phyllis — We'll grant you that you know your local military real estate history much better than do we, but your arguments make no sense, and you completely misunderstand our point of view.*

*If Travis Marina and the Presidio YC are not a boondoggle, and if, as Jack Machun, President of the Presidio YC Governing Council, claims in the next letter, they are both self-sustaining, why do you want to let them slip away? If you and Jeffrey Keeton — who we presume is a close relation, if not your husband — want to press for the Travis sailing school to be moved elsewhere, that's fine. But we don't understand your desire to eliminate the possibility of other military personnel — or some other entity — restoring and using it?*

*Where did you get the idea that we're in favor of a convention center at Horseshoe Cove? We hate the idea, as for more than 30 years Horseshoe Cove has been our secret shoreside hideaway when we've needed to chill out. Plus, the last thing Southern Marin needs is more people, cars and buildings at the expense of open space. Our fervent desire is that the Travis Marina and Presidio YC be fixed up — as Machun claims can be done — and be used by the military. But if that can't be done, or if you military people don't have the fight in you to try to make it happen, then we'd like to see some other entity take over the facilities and update them. Our only goal is that a marina facility yacht club not be lost. You and your husband's goal — which makes no sense to us if you love sailing and support recreation for the military — seems to be to make sure such a cool and unique facility is lost. It makes us wonder if you're not double agents for the evil forces of the convention center crowd.*

### ↕ ANOTHER VIEW OF THE PRESIDIO YC SITUATION

*Latitude is correct. Jeffrey Keeton's portrayal of the Travis Marina at Horseshoe Cove was "as gloomy as a foggy and windy February afternoon in the Cove."*

Fortunately, the real picture is not nearly as grim as Keeton painted it. The boat rentals and sail training have provided a significant amount of recreational activity to members of the Armed Forces and their families. During 2007, over 550 active duty personnel, their dependents and community members, went sailing in Travis Marina boats, and countless went sailing in private boats. In addition, military and non-military members and guests participated in social functions such as Workday Dinner, Opening Day, Independence Day Picnic and the Fleet Week Picnic. Travis Marina also regularly hosted weddings, birthday parties, and musical events that were well attended by locals and out-of-towners alike.

As far as the docks being in disrepair, there is some truth to that claim. However, a large capital expenditure hasn't been made recently because of the short-term nature of the lease extensions that have been granted to the Air Force by the National Park Service. The three-year lease extension negotiated in '06 does not lend itself to large investments.



# For the record...

Congratulations to all the North Sails customers who made 2007 the most successful year in our history. For a complete 2007 North Sails victory list, log on to...[www.northsails.com](http://www.northsails.com)

All North Sails products are produced in owned or fully licensed North Manufacturing facilities.



Any North customer who finished 1st, 2nd, or 3rd in a North American regatta in 2007 can register for a **FREE North Sails Bullet T-Shirt** by logging on to [www.northsails.com](http://www.northsails.com) (one shirt per customer). Want to win more races next season? Call your nearest North Sails representative today...

**FREE!**

Offer expires April 1, 2008.

**Channel Islands** 805-984-8100  
**Long Beach** 562-795-5488  
**Marina Del Ray** 310-827-8888  
**San Diego** 619-224-2424  
**Sausalito** 415-339-3000



# Outboard Motor Shop

Where the professionals shop!

(formerly Seapower Marine)



## See us at the Pleasanton Boat Show

C-Dory • Skagit Orca  
Boston Whaler • Evinrude

## Boat Show Savings!

BOSTON  
**WHALER**

2007 Model  
**CLEARANCE SALE\***

### More Fun. Less Fuel.



- Quiet, 4-stroke technology
- Unsurpassed fuel economy
- Transistorized pointless ignition
- Ideal for sailboats, small tenders

IDEAL FOR  
SAILBOATS  
AND  
SMALL  
TENDERS



POWERED BY

**HONDA**  
**MARINE**

Meets EPA  
2006 & CARB  
2008  
Emissions  
Standards!

© 2007 American Honda Motor Co., Inc.

Always wear a personal flotation device while boating and read your owner's manual.  
5-Year Warranty Offer good on all new Honda outboard engines purchased through 3/31/08.  
Check with participating dealers for complete details.



### BRISTOL FINISH INTERIOR ONE-PART POLYURETHANE

We use it and swear by it!

### RANGER TUGS

R-25

110 hp Yanmar, 3 GPH, cabin heater, diesel generator, air conditioning, fresh water, marine head, 1 burner stove, holding tank.

Call for viewing!



At the Boat Show

[www.outboardmotorshop.com](http://www.outboardmotorshop.com)

(510) 533-9290

333 Kennedy St., Oakland, CA 94606 • Fax 510-533-3374

\*Limited Inventory

## LETTERS

Once the National Park Service and the Air Force agree to a long-term lease, it's certain that the general infrastructure will be greatly improved.

The Air Force document describing the relationship between the Travis Marina and the Presidio YC states, "The Presidio YC is an integral part of the Travis Marina." The Travis Marina/Presidio YC get full support from officials at Travis Air Force Base. The Base Commander has met with Brian O'Neil, Golden Gate National Recreation Area General Superintendent, initiating discussion for a longer-term agreement with the Park Service. The Wing Commander at Travis truly feels that Travis Marina is a significant recreational asset.

You were wrong in being curious about "what kind of Treasury-draining boondoggle created" the Travis Marina/PYC. The marina is a NAF (Non-Appropriated Fund) facility. Not one cent of taxpayer money is spent on it. It is entirely self-supporting from revenue generated by club dues, slip rental fees and facility rentals. According to Air Force policy, if the marina does not continue to be self-sustaining it will be shut down. In fact, the marina generated excess revenue that assisted other Morale, Welfare and Recreational activities such as the base day care center that provides day care at less than cost.

You were wrong again when you said "the marina ought to be made available to folks or organizations with greater vision and resources." I cannot think of a greater vision than providing recreation for the men and women of the Armed Forces, who daily make sacrifices in the defense of our nation

Jack Machun

President, Presidio YC Governing Council  
San Rafael

Jack — We thank you for your two corrections. Given Keeton's gloomy assessment, we somehow assumed that the facility was a big money loser. If it's not, why are they so intent on it being lost?

### OTHER COMPLICATIONS

Thank you for printing my September letter about the problems that I was having getting to use my Vallejo-based Marquesas 56 catamaran *Amani*. I got several generous offers of help, and *Latitude's* reply and advice were most helpful to me — and others, I'm sure.

I've already taken some of your recommended steps. I have most enjoyed tacking against the current going out to Point Pinole with no crew. My cat tracks as well as my Volvo. I have also beat into 20-knot winds — not such a good idea with a cruising cat. I also ran aground near San Rafael with the tide going out. But the worst was when I rammed the dock hard enough to bend the seagull striker, the A-frame structure on the forward beam that maintains the structural integrity of the bow and keeps the hulls from being pulled together. The one thing I haven't practiced is sailing into the marina, something that I wouldn't want to try with a crosswind.

There were several things about your suggestions that really stood out. First, making a commitment to weekend sailing. This would mean gathering several crew who would always be there. That would be an opportunity for me to expand my social network on the waterfront. I knew this all along, as I had frequently been advised to do similar things such as join a sailing club and take a navigation class. But I had an excuse. I was so wiped out by my work at Napa State Hospital that I just wanted to kick back on the weekends. Yes, I 'retired', but kept working. My next job required me to stay in hotels

# COME VISIT COYOTE POINT MARINA:

*The Peninsula's Complete Recreational Destination!*



**RECENT  
DREDGE  
COMPLETE!!**



## ***BERTHING***

- Slips to 40' available
- 22' inside ties for \$85 per mo.
- Multihull side ties available
- Check out our rates!

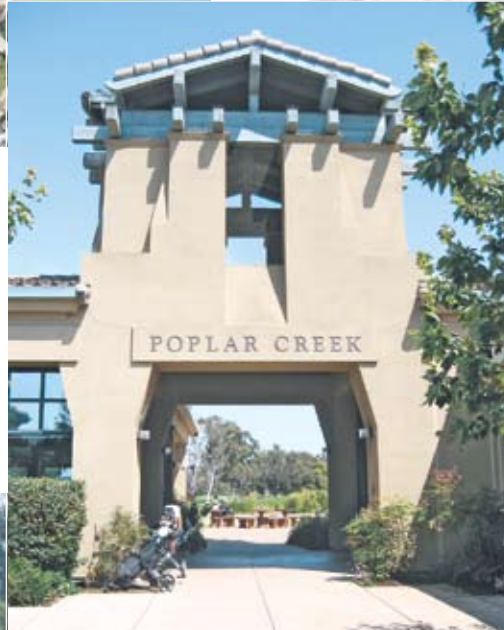

## ***FUEL DOCK & PUMP OUT***

- Open 7 days per week
- Gas and diesel available
- Check our prices
- Free pump outs



**GREAT  
WEATHER!**



## ***COYOTE POINT RECREATIONAL AREA – HOME TO:***

- Coyote Point Marina
- Poplar Creek Golf Course
- Coyote Point Park
- Captain's House Conference Center
- Beach, Picnic & BBQ Areas
- Coyote Point Yacht Club
- Dominic's Restaurant
- Magic Mountain Playground
- Coyote Point Museum
- Shoreline Trail

**COME FOR A VISIT – WE THINK YOU'LL STAY**  
*Call us and mention this ad for a FREE One Night Guest Berth*

**COYOTE POINT MARINA ~ 1900 Coyote Point Drive • San Mateo**  
**650.573.2594**



# HYDROVANE

SINCE 1968

## Survive Your Dream



Courtesy Jimmy Cornell

See John, Karen & Will at the Seattle and Vancouver Boat Shows

'Great Atlantic Gear Test'  
Always rated #1 or #2!

### YACHTING

MONTHLY October 2006

**100**  
best bits of gear – ever!

**HYDROVANE included twice!**

UK's prestigious YACHTING MONTHLY is celebrating its centennial and is celebrating its centennial by nominating the all time favorite equipment for its feature "100 Best Bits of Gear...EVER". HYDROVANE was selected twice...and both times as first choice.

Hydrovane is both:  
★ Self Steering  
★ BEST Emergency Steering

[www.hydrovane.com](http://www.hydrovane.com)

SPONSORS OF:  
★ Baja HaHa  
★ ARC and World ARC  
★ Carib 1500

## Announcing New Product!

### ECH<sub>2</sub>O Tec Watermakers

Truly Reliable – Amazing Prices!

[www.hydrovane-watermakers.com](http://www.hydrovane-watermakers.com)

604-925-2660

[info@hydrovane.com](mailto:info@hydrovane.com)

## LETTERS

during the week and drive long distances through traffic — when all I wanted was to be home on *Amani*. Every night I used to walk down to the dock thinking how nice it would be to go sailing right then — but whoops, there was nobody to do it with. And with such a big cat, I needed a second set of eyes, as well as somebody who knew the meaning of 'head up' and how to secure a line to a cleat. It had me thinking that I could have just jumped into that little racing boat in the next berth and gone sailing myself in the perfect weather. Shoulda, woulda, coulda.

The idea of trading down to a smaller cat and starting over would have given me the do-it-yourself thing again. It would also have given me some much needed money. I dreamed about spending the night on the hook at China Camp, a place recommended by Harriet and Tibor on *Baja*, the huge cat next to mine in Vallejo.

Unfortunately, I have other complications besides money and work. I have problems — and not just figuratively — with my brain and my heart. I take pills to prevent seizures, but they give me an unsteady gait that gives me a tendency to trip and hurt myself. And that's on solid ground, not a boat that's moving. In addition, I had very serious heart surgery in '92, which has left me with an arrhythmia and low blood pressure. I needed to be shocked a few months ago to get me out of it. I don't want to die at sea, nor do I want a full-time paramedic and/or babysitter following me around.

What's the solution? If I wanted to stay on the water, it might be a Grand Banks 42 Europa, which I could enjoy on the Bay and up the Delta. There's just one problem — it would require using fuel for propulsion as opposed to the wind. So I guess it would be best if I just had a small, easy-to-singlehand sailboat at Vallejo, where I like living.

What irony! I just retired for real. No more professional work for me. But I'm lonely, miss all the human contact that I used to have, and need to keep myself busy. Now I could really devote time to going out sailing all the time and making waterfront social connections. I will do this anyway on another path, but without fulfilling my big dream of sailing far away.

So *Amani* is for sale. I moved to a friend's house in order to clean her up and cherry her out. My big girl sure does have sexy lines. Anyway, I'm getting over the loss gradually, and am holding on to the vision of my next vessel.

Doug Smith  
*Amani*, Marquesas 56  
Vallejo

*Doug — Big catamarans are fabulous boats, but given your health issues, we'd have to agree that such a boat isn't right for you. What a shame.*

*By the way, sailing a big cat like *Amani* into a harbor, particularly one like where you keep your boat in Vallejo, would be insanity. There are some things you can do with a Moore 24 that you can't do with a 28-ft-wide cat. But when it comes to beating in 20 knots on San Pablo Bay, it's not only a great idea, it's some of the most fun that you can have with a cat. You grind the smallest jib tight, lower the main traveller all the way to leeward, sheet in the main so it's as flat as a piece of plywood — and go like a bat out of hell!*

*Anyway, good luck on selling your cat and finding a new boat of your dreams.*

### WELCOME TO THE CRUISING LIFESTYLE

Hola from a sunny cruising destination!

Here we sit in the shade of a palm, toes buried in the sand,

# Make Your First Ocean Passage a Great One

The School of  
**SAILING & SEAMANSHIP**  
| Orange Coast College



## LEARN WHAT IT TAKES...

to make a major cruise under sail during our 23rd offshore sail training voyage. Our 2008 schedule offers you a choice of shorter excursions in prime cruising areas, exotic land-falls and classic ocean passages.

Our emphasis is on helping you build skills in an environment of fun and great sailing. Many who sail with us are planning voyages of their own—there is no better way to prepare. Underway, we provide in-depth experience in vessel management, safety, provisioning, electrical and plumbing systems, celestial navigating, anchoring, sail handling, weather routing, and heavy weather.

Along with eight other crewmembers, you'll sail in all conditions, standing watches and steering as *Alaska Eagle* sails 180 to 240 miles a day. Delicious meals are prepared by the ship's cook. Everyone has a comfortable berth, and double cabins are available for couples and single women.

*Alaska Eagle* is owned by one of the nation's premier non-profit sailing schools. Designed by Sparkman & Stephens and strongly built of aluminum by the Royal Huisman Shipyard, *Alaska Eagle* (ex Whitbread winner *Flyer*) has logged more than 350,000 offshore miles. She has a comfortable four stateroom interior and all the latest electronics and cruising gear. She is Coast Guard certified for All Oceans.

## 2008/2009 SKIPPERS – *Sail and Learn with the Best*



Since Rich and Sheri first sailed aboard *Alaska Eagle* from England to California in 1982, they have been aboard as skipper and mate for the majority of her voyages. Combined, they have sailed more than 550,000 miles, including three Atlantic crossings, more than 30 crossings between Hawaii and the West Coast, 13 equator crossings, and many miles through the South Pacific between Tahiti and Australia. In between, Rich and Sheri have built three boats, virtually by themselves. In their first boat, a Farr 44, they circumnavigated South America. Their next boat was a 54 foot aluminum sloop in which they voyaged to Antarctica. Their third boat, the Farr 44 *Tabu* has just been launched and is ready for adventure.

Licenses held: USCG Master Upon Oceans • STCW International Yacht Master (RYA/DOT) • US Sailing Instructor: Keelboat, Cruising, Coastal Navigation

## ALASKA EAGLE VOYAGE SCHEDULE

**Looking for Rough Stuff? Here's our heavy weather leg:**



**Auckland – Raivavae – Tahiti May 15 – Jun 5, 2008**  
*Predominately an upwind passage, heavy weather and an exotic landfall combine to make this a challenging voyage.*

**Raiatea – Fanning – Hawaii**  
**Jun 22 – Jul 12, 2008**

*Leaving the legendary island of Raiatea, this passage includes a stop at Fanning Island and an equator crossing officiated by King Neptune.*

**Hawaii – San Francisco**  
**Jul 15 – Aug 1, 2008**

*Conditions range from upwind sailing and squalls to exquisite reaching conditions. Sailing under the Golden Gate Bridge brings a picture perfect ending to this trip.*

**2009 Newport to Cabo Race**  
**Mar 9 – Mar 15, 2009**

*Alaska Eagle will be the communications boat for this downwind race. This is a great trip for those thinking about taking their own boat to Mexico.*

**Baja Bash - Cabo to Newport**  
**Mar 18 - Mar 26, 2009**

*An ideal trip for those wishing to test their coastal skills in a variety of weather conditions.*

To learn more: [www.occsailing.com](http://www.occsailing.com)

To request a color catalog or specific info: **949-645-9412**

Or write: *Alaska Eagle* Voyages, 1801 W. Coast Hwy, Newport Beach, CA 92663



# Seawear™

Nautical and Celtic Jewelry



Winter 2008

[info@seawear.com](mailto:info@seawear.com)

[www.seawear.com](http://www.seawear.com)

## LETTERS

watching the sweet sun melt below a crimson horizon whilst sipping on iced tea or coconut water laced with rum. Sounds idyllic, doesn't it? It is.

We are here and you are there. We wish you were here, too, but not all at once! The 'we' I speak of are marine professionals, some ex-Navy, some with certain attributes that far out-qualify our chosen trades and lifestyles, but all with a tale to tell and many sea miles under the belt. We offer our experience and skills to folks who just might need it. Sometimes we do it for a handshake and a nod, sometimes for a bottle of wine or a meal, but sometimes for the great Greenback, too. After all, we've all made our investments in time and experience to have gotten this far.

Most often you'll find us in far away places where there is no one else to help you keep your dream afloat. But we've been there, and having spent a lifetime afloat all over the world, know what breaks down, how to fix it, and have had the foresight to bring along all those little bits and pieces that will keep us — and maybe you — going. I'm speaking of the stuff that keeps the diesel engine running, the nav lights burning, the beer cold, and the ice cubes tinkling.

But we're a dying breed and, as the immediate cruising grounds of the West Coast become more commercialized and the basic cost of living continues to rise, we're forced to move further off the beaten path.

So for those of you who make it past the Ha-Ha, look out for us lifetimers! We'll probably have more wrinkles for our given age, but we might have some interesting stories to tell, too. Our boats won't be quite as shiny, but they'll be clean on and below deck, and just as seaworthy, if not more so, than your boats. We ain't gonna tell you where it's at, figuring that you can work it out for yourselves.

Anyway, welcome to the cruising lifestyle. We bet you'll wish you made the break sooner.

Miguel Miguel

Somewhere South Of The Border

### ↑↓WHO DESIGNED ADELE?

In the October 5 *Lectronic Latitude*, you reported that a West Coast family purchased the 180-ft *Adèle* through KKMI in Richmond. Who designed that ketch — Bob Perry?

P.S. We sure love *Latitude*. What a service to West Coast sailors!

Ted Johnson

Liveaboard on a Bob Perry-designed Islander Freeport 36  
Seattle

*Ted — Thanks for the kind words. Adèle was designed by Hoek Naval Architects in the Netherlands, which was started by Andre Hoek in 1986. In the last 21 years they have been respon-*

COURTESY ADELE



**Hoek designs have a distinctive style, and to our thinking are very attractive.**

*sible for a tremendous body of superb work, much of it being large classic-looking yachts with modern underbodies using high-tech techniques and materials. The average sailor is most likely to be familiar with the Hoek line of Truly Classic — and truly expensive — yachts. If you enjoy looking at beautiful yacht design, we suggest you visit [www.hoekdesign.com](http://www.hoekdesign.com).*

# South Beach Sailing Center

*Design and Upholstery*

**415.543.1887**

**[nbmc@earthlink.net](mailto:nbmc@earthlink.net)**

**[www.northbeachmarinecanvas.com](http://www.northbeachmarinecanvas.com)**

**NORTH  
BEACH  
MARINE  
CANVAS**

Pier 40  
The Embarcadero  
South Beach Harbor  
San Francisco

YACHT: CARPE DIEM

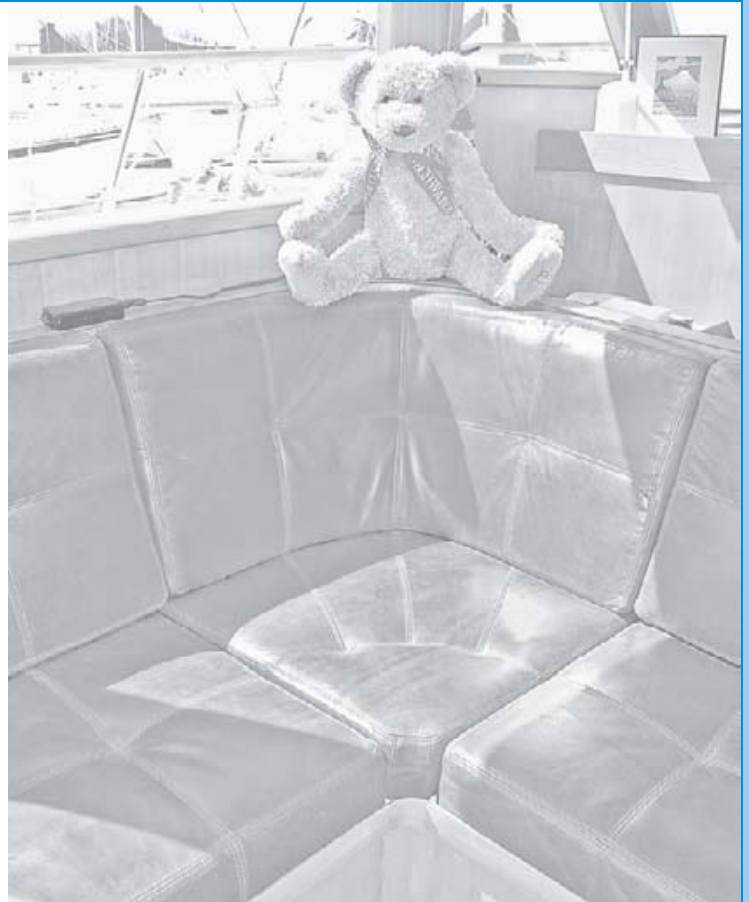

## South Beach Riggers

**Winning  
Technology for  
the Hot Race or  
the Casual Cruise**

- Expert advice, sales and splicing of Vectran, Spectra, Technora, and Dacron by our certified splicer
- Professional survey and tune for your rig
- Standing and running rigging replacement
- Fabrication and hydraulics
- More than 100,000 miles racing and cruising experience



### TWO LOCATIONS

**399 Harbor Dr. • Clipper Marina • Sausalito • 415.331.3400**  
**Pier 40 • South Beach Harbor • San Francisco • 415.974.6063**

## The difference between a boat and a yacht



- Mobile Service: *We Deliver!*
- Washing
- Waxing
- Varnishing
- Interior Cleaning

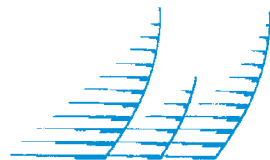

**Westwind**

Complete Yacht Care

*Serving the entire Bay Area for  
more than 20 years*



**(415) 661-2205**

Pier 40, South Beach on the Embarcadero • San Francisco

Call Toll Free **888-828-6789**

[westwinddetailing@sonic.net](mailto:westwinddetailing@sonic.net)  
**[www.boatdetailing.com](http://www.boatdetailing.com)**



Pier 40 • South Beach Harbor • San Francisco





See us at  
the SEATTLE  
BOAT SHOW

- Super efficient
- High reliability
- Worldwide sales & support



We have a watermaker to fit any need,  
from 150 to 1000 gallons a day.

#### WEST COAST DEALERS

**Emerald Harbor Marine, Inc.**  
Seattle, WA 98199  
Tel: 206-285-3632  
[www.emeraldharbormarine.com](http://www.emeraldharbormarine.com)

**Svendsen's Boat Works**  
Alameda, CA 94501  
Tel: 510-521-8454  
[www.svendsens.com](http://www.svendsens.com)

**Channel Coast Marine**  
Oxnard, CA 93030  
Tel: 805-985-0220  
[www.channelcoastmarine.com](http://www.channelcoastmarine.com)

**Outbound Yacht Services, Inc.**  
Dana Point, CA 92629  
Tel: 949-488-0652  
[www.outboundyachtservices.com](http://www.outboundyachtservices.com)

**Daily Marine**  
San Diego, CA 92106  
Tel: 619-222-9613  
[dailymar@aol.com](mailto:dailymar@aol.com)

*Your Dream, Realized.*

Spectra Watermakers • Tel: 415-526-2780  
[www.spectrawatermakers.com](http://www.spectrawatermakers.com)



## LETTERS

*Adèle was built at Vitters, which is also in the Netherlands. Designed by Hoek and built by Vitters is about as fine a pedigree as a yacht can have.*

### ↑↓ HOW CAN WE REACH DOUG PETERSON?

Can you or anybody else tell us how to get in contact with naval architect Doug Peterson? He custom designed my Peterson 35 back in '73, and over 40 of the boats were eventually built. *Pacific Yachting Magazine* would like to do a story on the history of the design, and we'd like to get some comments from Peterson.

Vernon W. Ruskin  
Jolly Olly IV, Peterson 35  
Royal Vancouver YC

*Vernon — For those who weren't sailing in the '70s and '80s, Doug Peterson came out of nowhere — and San Diego — to rapidly displace Sparkman & Stephens as the premiere designer of non-ultralight racing boats. As we understand it, Peterson did it the old-fashioned way — his grandmother gave him the money necessary to design, build and ship a boat to the One Ton Worlds in Europe. The success of his boat at that and subsequent regattas quickly propelled him to worldwide prominence.*

*However, Peterson has never been the gregarious type and didn't give a lick for publicity, so it comes as no surprise to us that he's hard to find. He's done a lot of America's Cup design work in recent years, mostly for Prada. His interest in boats is as keen as ever. It's our understanding that he owns an 8-Meter, a 9-Meter and a 12-Meter, all in Europe, and is partner in a Caulkins 50 in San Diego. Of these, the 8-meter is the most interesting. Originally known as Lillian II, she was built by Fife in 1907 and was later renamed Synnove III. After purchasing her in Newport Beach, Peterson disappeared and the historic yacht sank at her mooring. He immediately had her shipped to the renowned Argentario yard in Italy for storage and restoration.*

### ↑↓ THERE IS A BETTER WAY

There is a better way to use a Mac computer to navigate than, as you reported in the September issue, using something like Nobeltec while running Windows on a new Intel-based Mac computer. GPSNavX is a small company that has been making excellent native Mac navigation software for a few years. I've been using it for five or six years, and have been very happy with it. I don't work for them, but I do like to support small outfits. Readers can check out their website at [www.gpsnavx.com](http://www.gpsnavx.com).

John Swain  
Planet Earth

*John — We apologize for being more than a little behind the times with that funky recommendation. In fact, we've gotten a number of letters from Mac users such as yourself who have reported very high satisfaction with GPSNavX. They report that, not only does it do everything that Nobeltec does, but it costs a fraction of the price.*

*Speaking of Mac, it boggles our mind that, thanks to the recent dramatic run up in the price of Apple stock, that company now has a significantly greater market capitalization — \$170 billion versus \$150 billion — than IBM.*

### ↑↓ CHARTS FOR GPSNAVX ARE AVAILABLE

Jim Innes offers server space for Mac users to store and share their digital charts at [www.globalfusion.com/Charts/in-](http://www.globalfusion.com/Charts/in-)

Looking for something Boaty??

Northern California  
**BOAT-SHOW**

**PROFESSIONAL SEMINARS**

How to Choose a Wakeboard that's Right for You - Fishing Stripper in the Delta  
What's New & Hot in the Electronics World - Wake Surfing from A to Z  
Boat Maintenance How to - Facts Versus Myths - Boating Destinations



*Cruising, Racing & Trailerable sailboats, dinghies, rigids, boat graphics, electronics, auxiliaries, safety equipment & toys!*



**\$2.00 OFF  
Admission**  
*Bring this ad!*



**January 4-13, 2008**



TOYOTA Alameda County Fairgrounds, Pleasanton TOYOTA

go to [www.ncma.com](http://www.ncma.com) for Discount Tickets 1(800) 698-5777



# Sailing Away?

Call Today  
for Winter  
Pricing

We build custom  
sails to suit your  
needs, your boat,  
your plans.



Keep cruising with  
**HOGIN SAILS**



- New racing or cruising sails
- Roller furling conversions
- Boom and canvas covers
- Repair and service

In the Alameda Marina at  
1801-D Clement Ave., Alameda, CA 94501

**510.523.4388**

Mon-Fri 8:30am to 5pm  
Saturday by appointment only

sales@hoginsails.com  
service@hoginsails.com  
www.hoginsails.com

## LETTERS

*dex.html*. He has charts for all over the world and adds more all the time. I was able to get some charts for Western Mexico to use with GPSNavX, but they don't have as much detail as I'd like.

Since the charts are not specific to Mac or PC, I assume they are just not available. This seems unbelievable since there is so much nautical traffic in Western Mexico. Maybe some of your readers have had more success at getting digital charts for Western Mexico that are compatible with GPSNavX.

Richard and Tudy Taylor  
*Elysia*, Cheoy Lee Offshore 40 & *La Brisa*, Mason 43  
Durango, CO

*Readers — We'd like to find out, too. Anyone?*

### ↑↓ **PROOF THAT AN INFLATABLE BOARD WORKS WELL**

As a first-time participant in the Baja Ha-Ha, I want to say a big 'thank you' for such a well-run event. My crew and



ELECTRONIC / RICHARD

**"It's me, Greg! I'm really catching a wave on my inflatable surfboard."**

sleeping cots for our crew.

I'm also the guy who was surfing the inflatable surf-



ELECTRONIC / RICHARD

**Greg not only caught it, he got a long and fast ride at Bahia Santa Maria.**

board at the point at Bahia Santa Maria, and I think the Grand Poobah might have gotten a photo of me riding a wave. My friends are doubtful that the waves were that good and that my inflatable board worked that well. So is there any chance that you could publish a photo of me riding my board?

Greg Boyer, Crew  
*Fidelitas*, Tayana 460

*Greg — How about two photos, one of you dropping in that shows your inflatable board, and another of you moving on down the line? The Poobah can confirm that you not only got a ride, but that you got one of the better rides of the day.*

### ↑↓ **NEVER GO ALOFT WITHOUT A SAFETY LINE**

In the December 12 *Lectronic* there was the following item about Commodore Eugenie Russell of the Punta Mita Yacht & Surf Club: "Commodore Eugenie had reason to smile while signing membership cards for the Punta Mita Yacht and Surf Club. She'd been at the top of a 100-ft mast on a main halyard the day before because the splice failed on the halyard."

☎(510) 236-6633 • fax: (510) 231-2355  
 yachtsales@kkmi.com • www.kkmi.com  
 530 W. Cutting Blvd., Pt. Richmond, CA 94804

Ask us about our Maritime Protection Program to find out what a warranty can do for the purchase or sale of your yacht.



**Nelson Marek Custom**

A 92-ft aluminum world cruiser. Recently repowered. Immaculate throughout and in perfect condition.

**\$2,850,000**



**Swan 601 Moneypenny (2005).**

This yacht exceeds the pedigree of her design, construction and the Nautor brand. Truly an extraordinary vessel whether your passion is to sail in world-class regattas or cruise in a high performance yacht.

**\$2,975,000**



**Nick Potter/Wilmington Boat Works 62' classic sloop (1938).**

Designed by renowned Nick Potter for Jascha Heifetz, *Serenade* has been completely restored and is in pristine condition.

Asking **\$1,200,000**



**Fox 44 (2006) Ocelot**

Tom Wylie/Kernan Yacht Design sloop rigged offshore racer. Carbon hull and spars, rod rigging, POB back stay with full complement of sails, and includes trailer.

Asking **\$395,000**



PRICE REDUCED

**Nordlund 65 (1995)**

Custom motor yacht designed for easy operation and comfortable living. Understated and tasteful accommodations in excellent condition.

Asking **\$895,000**



**Dubois Custom 50' (1989)**

Custom two cabin cruising yacht designed by Dubois Naval Architects. Exceptionally well thought out cruiser with many details, *Norther* is robustly built, very comfortable and easily sailed short-handed.

Asking **\$589,000**



**Santa Cruz 52 (1993)**

Beautiful, fast cruiser, set up for short-handed sailing. Maintained to very high standards, the hull has been repainted in stunning red with new bottom paint.

**\$490,000**



WITH WARRANTY

**Oyster 53 (1999)**

A semi-custom yacht which includes numerous detailed appointments. Designed to be modern and coordinated, while remaining practical and durable at sea.

Now **\$849,000**



**Swan 112 Song of the Sea (2002)**

One of the finest yachts produced by Nautor's Swan standing in a league with the super yachts. The vessel has been maintained to a very high standard and shows as new.



SOLD

**Nordic 46 Raised Salon (1992) Blue Point**

Robert Perry designed 2-cabin offshore cruiser set up for shorthanded sailing in comfort in all conditions. Built to the same high quality standards as all Nordic yachts, this is a one of a kind yacht perfect for the serious cruiser. Asking **\$209,000**





# Custom RIGGING by the Experts!

From outfitting traditional cruisers to fine-tuning cutting-edge racers, let West Marine's experienced staff design the ultimate package to optimize the performance and look of your boat. Custom rigging is available through any West Marine store location.











- PowerLite PBO
- Running Rigging
- Standing Rigging
- Dock & Anchor Lines
- Lifelines

Contact us at 888-447-RIGG, or visit our Onsite Rigging Locations in:

<b>Alameda</b> 730 Buena Vista Av. Ph 510-521-4865	<b>San Diego</b> 1250 Rosecrans St. Ph 619-255-8844	<b>Seattle</b> 1000 Mercer St. Ph 206-292-8663
--	---	--

## LETTERS

I hope that this means that she went up to replace a halyard with a failed splice, because if it meant that it broke after she went up, and she's smiling because she survived it, then maybe it needs some amplification.



ELECTRONIC / RICHARD

**When not nearly falling from the top of 100-ft masts, Commodore Eugenie puts her dagger through the hearts of men and women all along the Vallarta coast.**

The tallest mast I've ever been up was the one on the 82-ft M boat *Sirius II*, so I can relate to some of the risks — and rushes — of going up tall masts. But if there's a lesson to be learned, please pass it along.

Fin Beven  
Radiant, Cal 40  
San Pedro

*Fin — We apologize for the confusion, as there was an error between our reporter in Mexico and the editors in Mill Valley. What happened is that Eugenie went to the top of the mast of the Morrelli & Melvin 70 cat Humu Humu to do a little work. Once it was done, she came down safely. However, when the boat was taken out for a sail the next day, only the top batten of the main had been raised when the same halyard she'd gone up on the day before failed! Why it hadn't failed the day before with her at the top of the mast is unclear.*

*There are two lessons. The first is to never go aloft without a safety line — a rule Eugenie vows to adhere to for the rest of her life. The second is to be very careful when splicing lines, particularly newer ones with older ones.*

### ↑↓ THERE AIN'T NO SUCH ANIMAL

I'm in the market for a catamaran that's about 33 feet long in the \$50-60,000 range. Can you tell me if there is a consensus of opinion in the catamaran community as to whether some brands are better than others? I realize that each have different characteristics, and that I'd always opt for diesel over gas, and inboard over outboards. There seem to be a lot of Geminis out there and a smattering of others, but most of them are out of my financial league. Any suggestions?

Curt Christensen  
Planet Earth

*Curt — We think you're discovering one of the major drawbacks of cruising catamarans — that even the used ones are quite expensive relative to monohulls. To be honest, we doubt that you could find a 33-ft cat with running diesel inboards in that price range. And even among those that are outboard-powered, there just aren't going to be many to chose from. In fact, the only semi-modern one that comes to mind would be a Crowther 33, such as Chewabacca, the one the Winship family cruised from Alameda to Colombia.*

### ↑↓ WE SMELLED A TREMENDOUSLY FOUL ODOR

We decided to start our cruise down the coast of Baja from Ensenada on November 19, the same day and place the Baja 1000-car/motorcycle race started for La Paz. Rather than making a straight shot to Mag Bay and then Cabo, we decided that we'd gunkhole our way down. The news for our sailing friends is that the anchorages along the coast of Baja are, almost without exception, very poor for getting a good night's sleep.

# BUYING OR SELLING?

LARGEST SELECTION  
OF NEW & USED SAILBOATS  
IN ONE LOCATION



Office Space for Rent  
Yacht Broker Building

## BRING YOUR VESSEL TO OUR HIGH TRAFFIC SALES DOCK

List with a Marina Village broker and you have access to the Bay Area's best sales environment. Of course, it makes sense, buyers should come for the same reasons: better brokers, better boats, and more of them!

*Beneteau • Island Packet  
Wauquiez • Alerion  
Passage Yachts  
(510) 864-3000*

*Tartan/C&C Yachts  
of San Francisco  
(510) 769-9400*

*J/Boats  
Sabre  
Sail California  
(510) 523-6730*

*Catalina  
Farallone Yachts  
(510) 523-6730*

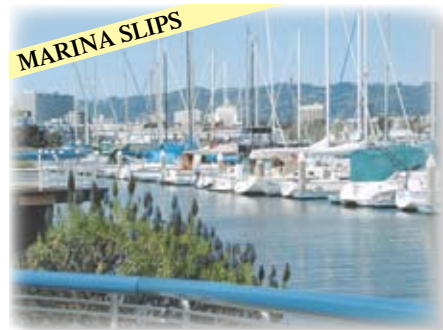

### MARINA VILLAGE

*Much More than Just a Marina*

[www.marinavillageharbor.com](http://www.marinavillageharbor.com)

**(510) 521-0905**

*Limited  
availability*





NEW SOCIETY  
PUBLISHERS

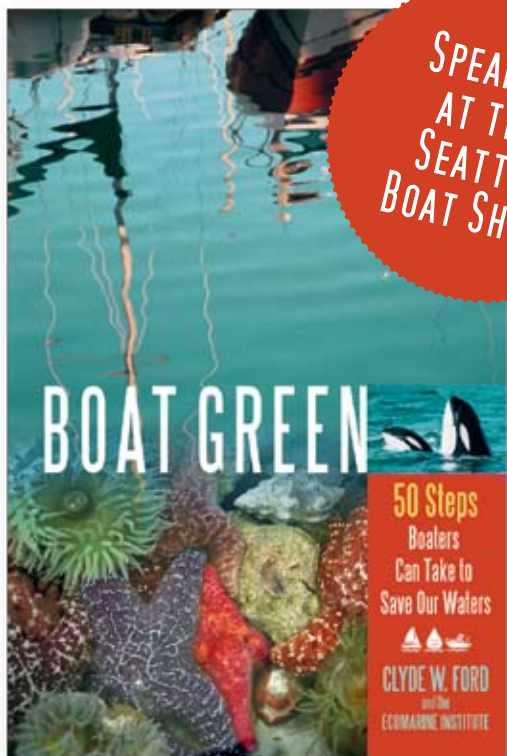

**BOAT GREEN**  
50 STEPS BOATERS CAN  
TAKE TO SAVE OUR WATERS

CLYDE W. FORD

Inspiring, practical and pragmatic  
From biodiesel to bottom paint, this  
handbook is a terrific resource for boaters  
wanting to leave a "green wake."

\$17.95



Order from our on line book store:  
[www.newsociety.com](http://www.newsociety.com)

LETTERS

We did have fog some of the time. For instance, we were going to stop at Isla San Martin, but bypassed it when we couldn't see more than 150 feet ahead. We ended up at Bahia San Quintin, which is well protected from the northwest swell, but is shallow and has many shoals. We reluctantly anchored in 13 feet of water — but that was only the beginning of the excitement.

As we were settling in for dinner, I heard a whale blowing — and then smelled a tremendously foul odor. It was a 35-ft gray whale. He or she circled our boat for a bit, then came in straight to our port beam, and gently began to rub its nose on the keel and side of our boat! This went on for about 20 minutes.

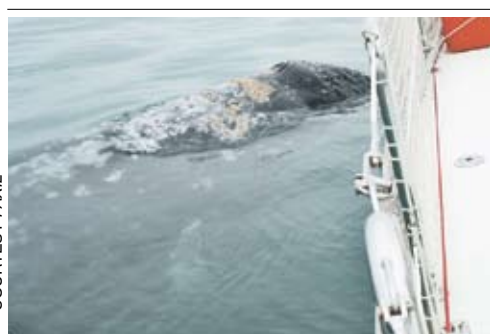

COURTESY PAXIL

"The whale rubbed our hull for 20 minutes . . ."

Then it began to rub our rudder. When I felt our boat rise up, I'd had enough. We started the motor and revved it in neutral a few times. This kept the whale away for a few seconds, but then it returned. By then it was almost dark, so I grabbed the flashlight and shined it in the whale's right eye. He didn't like this, so off he went to circle us a few more times before vanishing in the bay. I learned that you can be awestruck and still be scared to the point of shitting yourself. We barely slept the rest of the night because every time we heard a little noise we thought you-know-who had returned.

Other noteworthy stuff:

— We stopped at San Carlos Bay, which turned out to be a surfing mecca, of a sort. In fact, we felt as though we were treated to a surfing exhibition. Later, a boat from Santa Cruz anchored next to us, and we watched a crewmember from Santa Cruz climb to the spreaders and dive into the water.

— After an exhausting 95-mile overnight leg to Cedros, during which time we had stronger wind and bigger seas



COURTESY PAXIL

" . . . but when he started raising us by the rudder, that was too much."

than we would have liked, we pulled into Cedros around 9 a.m., having gotten very little sleep. We were welcomed by three boys flying kites on the breakwater, but after waving hello, went below to nap before taking a more active parental role. The thing is that Phoebe can sleep through anything, so she was bright-eyed and bushy-tailed and awaiting our attention. But she was nice and quiet while we napped.

— The Cedros anchorage is often ignored, apparently because it's only 30 miles away from Turtle Bay. But others told us that the port captain at Cedros Village is a very engaging personality who has been known to take visitors around on personally guided tours. He apparently wishes that more

# THE FINEST SAILS BEGIN WITH THE BEST SAILCLOTH

Our patented woven Vectran® sailcloth performs like the laminates with the durability of Dacron®, especially in roller furling applications. In fact, Vectran® is lighter, lower stretch, and retains its shape over a longer life than any sailcloth we've ever offered to cruising sailors. That's because Hood Vectran® is woven, not laminated to Mylar® film. And you can be sure that each sail we roll out is built by hand, with the same care and craftsmanship that has been the Hood hallmark for 50 years. To discuss your sailcloth needs—whether our state-of-the-art Vectran® or our soft, tight-weave Dacron®—give us a call today.

**HOOD Sails & Service**

**HOOD New Sails**

**HOOD Sail Repairs**

**HOOD Furling Conversions**

**HOOD Pickup & Delivery**

**HOOD Winter Discounts  
Now in Effect**

**Outbound Yachts  
New Outbound 52  
with Hood Vektron  
Vertical Full Batten  
In-Mast Furling  
Mainsail and 135%  
Vektron Genoa**

**PHOTO COURTESY  
SWIFTSURE YACHTS**

**HOOD**  
SAILMAKERS

**HOOD SAILMAKERS 466 Coloma Street, Sausalito, CA 94965**

**Call Robin Sodaro (800) 883-7245 (415) 332-4104 Fax (415) 332-0943 hoodsails@aol.com**

**Visit our website for Special Online Discount Pricing... [www.hoodsailmakers.com](http://www.hoodsailmakers.com)**



# FAR-OUT GENNAKER SAILING...



Now available  
in carbon!

...with an extendable  
Seldén gennaker bowsprit

- Gives the gennaker more clear air
- Facilitates rapid gybing
- Always ready for quick extension
- Makes for fast and efficient gennaker handling
- Can be fitted to most yachts
- Complete kit for deck mounting

[www.seldenmast.com](http://www.seldenmast.com)

 **SELDÉN**  
for sailing

Rig solutions for dinghies, keelboats and yachts. Aluminium and carbon spars. More than 750 authorised dealers worldwide.

Seldén Mast Inc. Tel 843-760-6278, [info@seldenus.com](mailto:info@seldenus.com)

## LETTERS

cruisers would stop to enjoy the village's hospitality.

— After leaving Cedros the following morning at 9 a.m., we quickly got clear of the island's influence and, with 18 knots of wind and following seas, made Turtle Bay in six hours. It was the best sailing of our trip to date.

Jeffrey, Patti and Phoebe Critchfield  
Paxil, Beneteau Oceanis 423  
Brickyard Cove, Point Richmond

*Jeffrey, Patti & Phoebe — Yours are some of the best whale-rubbing-a-sailboat shots that we've ever seen. Congratulations!*

*But what's this about Baja anchorages not having good anchorages for sleeping? As coastlines go, it's got lots of anchorages, and good ones, too.*

### ↑↓ FIVE EASY STEPS

We recently visited Puerto Vallarta, then went over to La Cruz de Huanacastle to visit the new Nayarit Riviera Marina. It's going to be beautiful! But on our way through the airport, we picked up one of the glossy tourist magazines that describes all the 'adventures' you can book in that tourist area. One of their suggestions was to go sailing. According to the publication, it's easy — as long as you follow their "5 Basic Steps To Sail:"

"1) Locate the broad reach.

"2) Displace the rudder until you get the sails in direction of the wind.

"3) Keep a course.

"4) When you get to a point where it will be necessary to tack (to turn around to change the course), displace the rudder at the time the backstays are loosened up.

"5) Tense the backstays to guide the sail according to the new position which is sought in front of the wind."

According to the publication, that's all there is to it — unless something was lost in the translation.

David and Jill Wolfe  
Escapade, Catalina 400 Mk II  
Marina Village, Alameda

*David & Jill — That publication does English about as well*

*as we do Spanish, so we're not going to be too critical. However, one of the many free glossy publications around Vallarta is Vallarta Nautica, which was started 10 years ago by cruisers Lew and Anneke Jennings, with all proceeds donated to local charities. They subsequently sold it, and it's now become "a world class, full-color magazine, covering everything in, on and under the waters of Banderas Bay." We've seen it, and it's not only very well done, it's accurate, and has a Resource Guide with 680 listings in 97 categories. New publisher John Youden re-*



LATITUDE / LADONNA

**Everything you need to know about sailing, surfing, kayaking and diving on Banderas Bay is in this free magazine.**

680 listings in 97 categories. New publisher John Youden re-



# MARINA RIVIERA NAYARIT

AT LA CRUZ

- UP TO 400 vessel capacity (30-400 ft.)
- Fuel station • Dry dock 150 ton travel lift • Yacht club
- Hotel Site • Condominiums • Restaurants & Bars
- First-class services and much more!



Marina Coordinates: Lat. 20°45'N • Long. 105°24'W





Canvaswork and Sailmaking are Sailrite's specialties and we're here to help you with your projects. Build it new, repair it, retro fit it— You can do it! Sailrite can help!

*Matthew Gerrit*



## Fabric



## Kits



## Thread



## Tools



**Sailrite**

For a free supplies catalog call 1-800-348-2769 or visit us online at [www.sailrite.com](http://www.sailrite.com)



1-800-348-2769  
[www.sailrite.com](http://www.sailrite.com)

## LETTERS

ports that a substantial amount of the proceeds will still go to charity. While the glossy guides are free in Vallarta, they can also be downloaded at [www.vallartanautica.com](http://www.vallartanautica.com) for \$10.

As for the Nayarit Riviera Marina, we've stayed there a few nights and agree that it's going to be a much-needed addition



ELECTRONIC / RICHARD

The addition of 400 slips at the new Nayarit Riviera Marina in La Cruz marks the dawning of a new nautical era on the north shore of Banderas Bay.

to Banderas Bay, one that gives mariners yet another choice. Vallarta Marina is terrific for those who want to be surrounded by restaurants and in the middle of what's becoming a very crowded and

busy city. Paradise Marina is for those who want an excellent facility with all the extras of a fine resort, and one that's away from the traffic but still not too far from town. The Nayarit Riviera Marina will be perfect for those who want to berth their boat in what's still an authentic and quiet little Mexican town, but one that's only 20 minutes from the airport and 30 minutes from the booming downtown.

### ↑↓ I'M A FANATIC BUT ONLY CARRY TWO GUNS ABOARD

I particularly liked two articles in the October issue of *Latitude*. The one on HF radio was very informative, and you can't say too many good things about Don Anderson, who provides all the free weather reports to cruisers in Mexico. It's actually Dr. Anderson, as he has a PhD in chemistry. I've been to Don's home and checked out his 90-pound Harris HF radio and his 75-ft directional antenna, the design of which he borrowed from the CIA. Very impressive.

The article on spear fishing was also good, but I'd like to add a few comments without trying to sound too officious. The author gets points for not using scuba gear to spear fish, and almost all the info in the article was accurate. But he wrote that he uses four spear guns and was considering the purchase of yet another. I'm a spear fishing fanatic, but I don't believe you need five spear guns. I only carry two, although I do carry a lot of spare parts.

I'd also like to point out that it's not a good idea to shoot at a fish that's in front of a rock. A good underwater hunter, like a good police officer, will always be aware of his/her back-ground and avoid shots that will damage his/her equipment. The tip of a spear shaft needs to be needle sharp, and killing 'rock fish' will quickly dull the point. When shooting fish in caves, I'd recommend a pole spear as a better choice. They are very simple, yet they work well on small fish.

The author also stated that he doesn't use a reel on his guns as he doesn't shoot large fish. But here's the problem I see with that approach: a nice 30-pound yellowtail swims right in front of his gun. It would be almost impossible not to take that shot, but without a reel or a trailing-line, the fish — and perhaps the hunter's gun — would be lost. A trailing line is simply a floating line, 50 to 75 feet long, that's attached to the gun, and, like a reel, allows the diver to swim to the surface for a breath of air while fighting the fish.

Regarding the selection of spear guns, pneumatic guns are high-maintenance and they lose power at depth. But if

# Why settle?



## **Ballena Isle Marina**

Alameda 510.523.5528

## **Jack London Marina**

Oakland 510.834.4591

## **Treasure Island Marina**

San Francisco 415.981.2416

## **Martinez Marina**

Martinez 925.313.0942

You don't settle for less, why do it with your marina? Join one Almar marina and gain access to seven Bay Area marinas. Almar's reciprocal program takes the hassle out of your boating weekend. A simple call to the marina office and you can spend the weekend at Jack London Square or Treasure Island. Maybe a trip to a few of Almar's seven Southern California marinas. We make it so easy you may find yourself using your boat.

Almar boaters receive a 10% discount on any fuel purchase at Jack London Square and Ballena Isle Marina. Jack London Square Marina has just upgraded it's fuel dock with high speed fuel dispensers and now has the fastest pumps in the Bay Area. You don't have to settle anymore.

Almar is the largest operator of saltwater marinas in the country. Almar Marinas provide a wide range of services and programs that few marinas or yacht clubs offer. Some of these programs include: monthly boating seminars, boat handling classes, navigation courses and organized outings to local anchorages. Each marina offers wireless high speed internet access, which can be used with your reciprocal privileges at any Almar Marina. To see the difference, visit one of our marinas this weekend.



[almar.com](http://almar.com)



# Slip Into Someplace Comfortable

Silicon Valley's newest and most convenient marina



Discover a touch of Italy with the quickest access to South San Francisco Bay. Bair Island's management team is committed to providing a truly excellent home for your boat.

- ★ Slips and side-ties from 30' to 75'
- ★ 30 and 50 amp power
- ★ Cable TV, DSL and phone
- ★ Calm, quiet and protected
- ★ Free parking
- ★ Heated shower and laundry facilities
- ★ Walk to shops, restaurants and movies
- ★ Office open 7 days
- ★ Dock boxes with lighting
- ★ Kids playground

## BAIR ISLAND MARINA



702 Bair Island Road  
Redwood City, CA 94063  
650-701-0382  
www.greatslips.com

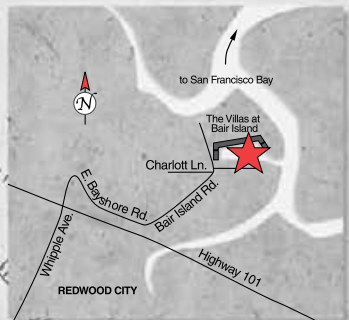

CALIFORNIA RECREATION COMPANY

## LETTERS

you always hunt in shallow water, the loss of power wouldn't be that significant. A bent shaft will render such a gun inoperable. The Riffe spear gun is outstanding, but it's also very expensive. The JBL is a very good workhorse, but stay away from the early guns, circa 1970, as they tend to pre-fire — meaning they go off without pulling the trigger. That's not a good thing.

A few more tips I'd like to share: Never aggressively pursue a fish, as you'll almost always lose it. Avoid making eye contact with a fish, as it's a strong indication to the fish that it's potential prey. Just before making a dive, remove the snorkel from your mouth. If you don't, air bubbles will slowly flow from the snorkel during the beginning of the dive, and they will scare the fish away.

Steve Albert of *Far Fetched* did a fine job on the article, but I hope I was able to add a little to the subject. By the way, I'm a graying member of the Long Beach Neptunes, the oldest active spear fishing club in the United States.

Thomas Blandford  
M/V *Imagine Me and You*  
San Carlos, Mexico

### ⇅ LONGER WOULD BE BETTER

We'd like to thank the Grand Poobah and the Ha-Ha staff for helping us have such a great experience on the last Baja Ha-Ha. Despite all of the warnings about the possibility of injury and death — which was one of the reasons we almost didn't go on the Ha-Ha — in the waivers we had to sign, the Poobah and his staff really did support, assist, and truly look out for the safety and enjoyment of every participant.

This was our first lengthy passage and, while we experienced no problems, we would have felt safe and supported if we had encountered any mechanical, electrical, or medical issues. In addition, we truly enjoyed sharing our experiences with other mariners at each of the stops, and felt that having one planned event at each stop was just perfect. The only improvement we can think of would be an extra day at Turtle Bay and an extra day at Bahia Santa Maria. However, we realize that you really try to keep the event to less than two weeks. Anyway, we really appreciated the Ha-Ha staff's hard work as well as the local expertise for each destination. We're certainly going to recommend the Ha-Ha to all of our friends who will be heading south in the future.

There was some talk of a site being set up where everyone could post the photos they took — particularly of other boats under sail. For example, we know that the vessel *Ticket* got some of our boat while we were flying our blue and gold chute, and we'd love to get digital copies. Has there been anything done with that?

Anyway, thanks again for giving us all the opportunity to experience what some of us believe will be the preface to our adventure of a lifetime.

Jan and Rob Anderson  
Triple Stars, Island Packet 380  
Sausalito

*Jan and Rob — Thanks for the very kind words, but what makes the Ha-Ha work is all the great participants.*

*We've just created a simple-to-use Ha-Ha '07 photo-sharing site at <http://picasaweb.google.com/Baja.HaHa.07>. Participants can view, download and upload photos to share with others.*

### ⇅ DISPELLING THE "SWARM OF LOCUSTS" RUMORS

Living in the Pacific Northwest, we didn't have ready access

# Yacht at Rest, Mind at Ease

[WWW.YACHT-TRANSPORT.COM](http://WWW.YACHT-TRANSPORT.COM)



SAFEST WAY TO SHIP • PREMIER SERVICE FOR ANY YACHT • RELIABLE FREQUENT SCHEDULES • UNIQUE DESTINATIONS • COMPETITIVE RATES

UNIQUE DESTINATIONS • COMPETITIVE RATES

PHOTOS BY ONNE VAN DER WAL

RELIABLE FREQUENT SCHEDULES • SAFEST WAY TO SHIP • UNIQUE DESTINATIONS • COMPETITIVE RATES • PREMIER SERVICE FOR ANY YACHT



WORLD CLASS YACHT LOGISTICS

**Dockwise Yacht Transport USA**

Telephone +1 954 525 8707

E-mail: [dyt.usa@dockwise-yt.com](mailto:dyt.usa@dockwise-yt.com)

**Dockwise Yacht Transport Europe**

Telephone +39 [0]10 278 9411

E-mail: [dyt.europe@dockwise-yt.com](mailto:dyt.europe@dockwise-yt.com)

**Dockwise Yacht Transport France**

Telephone +33 493 931 856

E-mail: [dyt.france@dockwise-yt.com](mailto:dyt.france@dockwise-yt.com)



# SOUTH BEACH

H·A·R·B·O·R

South Beach Harbor  
is a great way to experience San Francisco.  
Boats of all sizes are welcome in our  
protected deep water harbor. Bring your  
boat to South Beach and enjoy all the  
attractions of the city.



Two guest docks for boats  
up to 125'

20 guest berths up to 50'

Casual and fine dining nearby

Adjacent to AT&T Park

Easy access to transportation

24 hour security

Free pump-out stations

For Reservations:

415.495.4911  
fax: 415.512.1351  
sb.harbor@sfgov.org  
www.southbeachharbor.com

## LETTERS

to *Latitude 38* and all the great articles from people cruising all over the world. We had, however, heard stories of the "notorious" Baja Ha-Ha, including tales of exuberant Ha-Ha participants ruining anchorages along the Baja peninsula. One person described the Ha-Ha as being like a swarm of locusts coming through and devastating the landscape. As such, when we planned our cruise from Vancouver to Mexico, we planned to arrive at Ha-Ha stops well before or after the Ha-Ha fleet had come through.

As it turned out, we needed to get some parts that weren't available in Ensenada, and contacted *Tin Soldier*, a boat we knew from the Blue Water Cruising Association, and one that was going to be in the Ha-Ha, to see if they would be able to help us get the items. We arranged to meet up with *Tin Soldier* when the Ha-Ha fleet was in Turtle Bay. In fact, we were anchored at Isla San Benitos when many members of the Ha-Ha fleet went sailing by. The local fishermen even came out to our boat to ask why so many boats were sailing past. We explained that there was going to be a big sailors' fiesta in Turtle Bay.

Anyway, we left San Benitos the next evening for a short overnight to Turtle Bay. Thanks to 25-knot winds for most of the night, our planned eight-hour trip turned out to be much shorter. Not wanting to enter an unknown harbor at night, we hove-to outside Turtle Bay. But the sight inside the bay was amazing, as it was lit up like a city, thanks to 150 masthead lights glowing brighter than the stars!

We entered the bay at first light and sort of kicked ourselves, because the entrance is easy, even at night. After dropping the hook and having breakfast, we went in search of *Tin Soldier*. It wasn't hard to find them, as they were one of the few boats flying the Maple Leaf flag. After collecting the parts they had kindly picked up for us, we joined them on the beach for tacos, beer and Ha-Ha frivolities. We had a great time meeting the participants in this "notorious" event, some of them new cruisers, some of them very experienced, but everyone enjoying themselves in this new cruising environment. It was a fun afternoon in the sun and sand, with fellow cruisers swapping tales during the potluck and beach game activities. There was none of the outrageous, out-of-control, drunken debauchery that we had been led to believe happened at the Ha-Ha.

We also listened in on the morning roll calls, and were very impressed with the organization of so many vessels, the Grand Poobah's control of the daily details and gossip, and the obvious camaraderie the participants were sharing. It made us wish that we'd joined the fleet in San Diego.

We hung around Turtle Bay for several days after the Ha-Ha fleet had left on a spinnaker run south, and can report that it wasn't as though the town had been overrun by a plague of locusts. The *tiendas* still had lots of fresh tortillas, produce, and even beer.

A few days later we carried on into Bahia Magdalena, bypassing the Ha-Ha stop at Bahia Santa Maria for no real reason other than the winds were right for us. It was only later that we heard about 72 Ha-Ha participants being stuck on the beach overnight thanks to a combination of high surf and darkness.

A week or two later, we arrived in Cabo San Lucas, having enjoyed a leisurely trip down the outside of Baja, exploring the coastline. Cabo is such a busy tourist town, it would have been hard for the Ha-Ha to have had much impact.

From what we could tell, the 150 boats and 601 people in the Ha-Ha were a positive experience for the local communities on the Baja peninsula — as were the 50-or-so-boat-strong



**SeaPortal Ltd.**  
INTERNATIONAL  
Marine Group

**www.seaportal.com**

HOME

NEW BUILDS

SAILING YACHTS

POWER YACHTS

CHARTER

BROKERAGE

**NEW BUILDS:**

Building the boat of your dreams is a rewarding yet demanding endeavor. Seaportal can make the experience fun while providing knowledgeable guidance in the process. For more information go to [www.seaportal.com](http://www.seaportal.com)

**(415) 999-6144**

**H&L**  
marine woodwork, Inc.

**Yes We're Still in Business!!!  
Now Over 60 Years**



the ORIGINAL  
and still your  
best buy because...

- Made in U.S.A by skilled craftsmen using the latest woodworking technology.
- Consistent quality and styling year after year lets you add matching accessories anytime.



**The Best In Wood Products For Your Boat...**

- |                           |                           |
|---------------------------|---------------------------|
| Handrails                 | Laminated Tillers         |
| Shower & Cockpit Gratings | Bow Pulpits               |
| Swim Platforms            | Ladders                   |
| Racks                     | Pedestal & Lift Tables    |
| Doors & Drawers           | Pre-Fabricated Door Units |
| Panelling                 | Decking                   |
| Hatchboards               | Teak & Holly Sole Boards  |
| Ash Batten Panels         | Teak & Lumber & Plywood   |
| Moldings & Corners        |                           |

**H&L Marine Woodwork, Inc.**

2965 East Harcourt St., Rancho Dominguez, CA 90221  
(323) 636-1718 • (310) 638-8746 • Fax (323) 636-1720  
Email: [h.l@sbcglobal.net](mailto:h.l@sbcglobal.net)

less fuel  
less noise  
less pollution  
more power



OSSA Powerlite diesel-electric systems by Glacier Bay are up to 95% quieter.  
[www.ossapowerlite.com](http://www.ossapowerlite.com)

Glacier Bay, Inc. 2930 Faber Street Union City, CA 94587  
(510) 437-9100 (510) 437-9200 fax [www.glacierbay.com](http://www.glacierbay.com)



# SHAFT SHARK

**The best rope,  
line and debris  
cutter there is!**

Two piece unit

For both  
power and sail



AB Marine, Inc.

747 Aquidneck Ave.  
Middletown, RI 02842

401-847-7960

Fax: 401-849-0631

sales@ab-marine.com  
www.ab-marine.com



# Gori® propeller

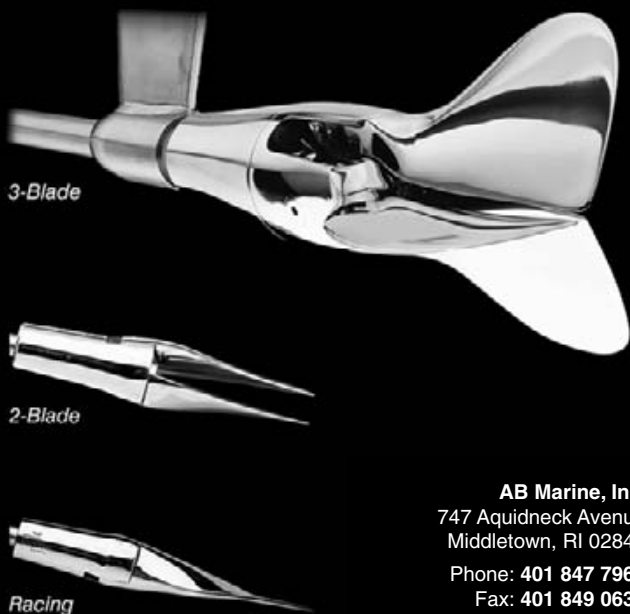

AB Marine, Inc.  
747 Aquidneck Avenue  
Middletown, RI 02842  
Phone: 401 847 7960  
Fax: 401 849 0631  
sales@ab-marine.com  
www.ab-marine.com

## LETTERS

FUBAR powerboat fleet that came through a week or so later. Neither of these events presented a problem for cruisers on individual boats, such as ourselves, along the coast of Baja. The only downside that we see to the Ha-Ha is that the participants don't have the time to thoroughly enjoy the rest of the other beautiful anchorages that Baja has to offer — anchorages that we enjoyed immensely.

I'm not sure how rumors get started, but we're out to dispel the "swarm of locusts" one about the Ha-Ha — and are even considering heading north next fall to join the Ha-Ha fleet of '08. So please keep up the great work and good times.

Geoff Goodall, Linda Erdman and Jessie the sailing dog  
Curare, Bowman 36  
Vancouver, B.C., Canada

*Geoff, Linda & Jessie — On behalf of the Ha-Ha, thank you for the very kind words. We've been extremely proud of the way the Ha-Ha participants have conducted themselves over the years. We're glad you saw fit to join everyone on the beach, as everyone is always welcome at the Ha-Ha social events.*

*By the way, we couldn't agree with you more that it would be great if the Ha-Ha could be a month or so long in order for folks to enjoy more of what Baja has to offer. Unfortunately, something like that just wouldn't be practical for most folks, and to our thinking, after two weeks it's time for folks to go off on their own or at least in much smaller groups.*

### ↑↓ BRAVO TO YOUR RESPONSE TO WHINERS

I'm writing this letter in response to those whiners who criticize the Ha-Ha but have never done one. They have no idea what they are talking about.

My wife and I did the '06 Ha-Ha aboard the Morgan Out-Island 41 *Bronco*. One of our crewmembers suffered a broken rib and multiple fractured ribs — and got excellent medical treatment at the clinic in Turtle Bay. A radiologist on another boat reread the X-rays for us so we would know exactly what her condition was. Another doctor gave us extra medication to ease the crewmember's pain. On top of that, other medical professionals in the fleet regularly inquired as to how our injured crewmember was doing.

I applaud *Latitude's* response to those whiners. Maybe they'll change their tune if they find themselves in need of help and some Ha-Ha veterans come along.

Bob Bauer  
Lady Ann, O'Day 27  
Alameda

*Bob — Thanks for the kind words. We probably got more positive reaction to our response to the 'Whiners' letter than any other in the last five years. If folks do a Ha-Ha and don't like it, that's fair enough. And while we certainly don't lose any sleep over it, we think it's lame for people who haven't even done a Ha-Ha to criticize it.*

### ↑↓ WAVE PERIODS AND DANGEROUS CONDITIONS

The loss of the crab boat *Good Guys* on December 4 brings up the subject of wave period and dangerous conditions for small boats. Although we hashed out this subject in the May and June issues of *Latitude*, I still feel an important point has to be understood about dangerous long period swells.

I totally agree with you that such swells are no problem as long as you are sailing in deep water. But a long period swell of 15 seconds or greater becomes a danger in shoaling bottoms like the ones surrounding the entrances to San Francisco, Tomales Bay, and surrounding the entrance and approaches

# FISHING FOR SAVINGS...DON'T LET THIS ONE SWIM AWAY

**20% OFF BOTTOM PAINTING PACKAGES** OFFER EXPIRES 1/31/08

(no salmon were hurt in the making of this ad)



**KKMI** Ask us about our **FREE** shuttle back to your car or marina & courtesy boat wash before delivery.

**Keefe Kaplan Maritime, Inc.**  
www.kkmi.com \* Ph. (510) 235-KKMI (5564)  
530 W. Cutting Blvd. \* Pt. Richmond, CA 94804

## THERE'S A NEW SHERIFF IN TOWN

Rated "EXCELLENT" & "BEST BUY"

Powerboat Reports®  
2004, 2005, 2006, 2007

# BLUE WATER® MARINE PAINT

KKMI® is pleased to promote Blue Water™, rated "EXCELLENT" by Powerboat Reports®. Blue Water™ contains higher concentrations of premium domestic copper & active ingredients, and only use virgin rosins, colorants & solvents in all antifoulings. Blue Water™ is the only distributed marine paint that offers a 1-year written warranty against premature hard marine growth.



## COPPER PRO SCX 67 HARD™ FULL SEASON - 67% COPPER - BOOSTED MODIFIED EPOXY

Blue Water® Copper Pro Scx 67 HARD™	<b>\$199.99</b>	
Pettit® Trinidad SR™	\$229.99	
Interlux® Ultra with Biolux™	\$239.99	



530 West Cutting Blvd. (510) 235-5564  
Pt. Richmond, CA 94804 KKMI.COM





*Happy New Year!*  
from all of us at Staal Sails

**A Full Service Sail Loft**

Providing Quality Customer Service  
and Competitive Pricing

Visit us at the  
**SEATTLE BOAT SHOW, West #25**  
Jan. 24 – Feb. 2 at Qwest Field Event Center  
**15% OFF NEW SAILS**  
**20% OFF FURLING HARDWARE**

801 Harris Ave., Bellingham, WA 98225  
**(360) 734-8559** or **(800) 234-6157**  
email: [drew@sailloft.com](mailto:drew@sailloft.com)  
Used sails listed on our website: [www.sailloft.com](http://www.sailloft.com)

**LETTERS**

to Half Moon Bay.

These distant swells come from far away storms and, when they approach our coast on a windless day, can appear to be relatively harmless. But these 'sneaker waves' have claimed many lives along our coast and just a short distance out to sea. These long-period swells are most common in the fall and winter months, and into early spring. It's very easy to get suckered into thinking that conditions are calm, and therefore cut over a shoal area or enter a harbor or bay that has a shoaling entrance, and get caught by a large, breaking sneaker wave.

Before I go out the Gate during the winter and early spring, I always check the offshore buoy data for the dominant wave period. It takes less than a minute, and gives other important data as well.

Nobody is going to argue with you that sailing into a short-period wave system of the same height as a long-period swell is going to be very uncomfortable. But the long-period swell, of the same height, has far more energy and is much more deadly as it passes over a shoaling area.

I'm only speculating, but I think this is what claimed the *Good Guys*, and it took them all at once and fast. The swell period that day was 17 seconds.

Tony Badger  
Kingfish

*Tony — We're glad you brought this subject up, because it's indeed the time of year for mariners to be particularly vigilant for sneaker waves. That said, a lot of people — and even safety authorities — don't seem to have a clue what a real sneaker wave is, confusing it with what surfers commonly refer to as the "wave of the day." Waves of the day might be considerably larger than the other waves, and they may be part of the set of the day, but in no way are they sneaker waves. Sneaker waves — at least what we consider to be sneaker waves — are large waves that inexplicably come out of nowhere on days when the surface of the ocean is very flat before and after the wave has hit. So flat that there's almost no discernible wave period. That's why they call them 'sneaker waves' rather than 'bigger than normal waves'.*

*We can remember a fishing boat being nailed by a sneaker wave near Baja's offshore Roca Ben, an Olson 30 being pitched in otherwise flat conditions off Marina del Rey, and boats being creamed at places like the entrance to Tomales Bay, Half Moon Bay and elsewhere. In all cases, the waves came out of nowhere on otherwise flat days.*

*According to the literature, sneaker waves are caused when a number of smaller waves become focused, meaning the individual wave peaks coincide to create a new wave that is the sum of those superimposed. We think this is a bunch of baloney, because there have been big sneaker waves when the ocean has otherwise been as flat as a mirror and where there were no smaller waves to coincide. Nor would this explain the fact that true sneaker waves only seem to occur between November and the end of February. And why don't waves coincide at other times of year? And please, let's not refer to what surfers call ordinary 'f-ckin' doubles' as sneaker waves — because they aren't.*

*Some authorities believe that most true sneaker waves occur along the coasts of Oregon, Washington, California and Baja. Others say it's a universal phenomenon.*

*What should Latitude readers take away from all this? Exactly what Badger suggests — stay in much deeper water than during the summer, and don't cross the bars outside the Gate. But if you must cross a bar or area of shallow water, do*

See us  
at the SEATTLE  
BOAT SHOW  
Concourse  
#2104

# wallas®

## SAFEFLAME

**85DU/270**  
Marine Diesel  
Stove with Heater Lid

**UNIQUE EFFICIENT DESIGN**

- Safe no-open flame operation.
- Exhaust vented outside, helps keep cabin dry.
- Lid up: cooking. Lid down: cabin heating
- Superb marine grade construction, great looking.
- Easy to install, either flush or surface mounted.
- Super clean, variable output combustion process.

Importer & Distributor for North America:

2144 Westlake Ave N Suite D  
Seattle, WA 98109  
Ph: 206-285-3675  
Fax: 206-285-9532  
[info@scanmarineusa.com](mailto:info@scanmarineusa.com)  
[www.scanmarineusa.com](http://www.scanmarineusa.com)

# For more than 25 years, yacht owners have been able to trust **PACIFIC COAST CANVAS** for the best in design, service and quality.

## • Offshore Dodger™

Welded aft handrail  
Bolt-on side handrails  
Lexan windshields

## • Baja Awning™

Lightweight and waterproof  
Durable and easy to launch  
Multiple side screen configurations



*Check out the new 'Special Edition' Jeanneau 45, with Dave at Cruising Yachts; with our new offshore dodger.*

## • Coastal Dodger™

Affordable designs  
Same high quality materials  
Same superior workmanship

## • Cruiser's Awning™

Easy setup off your dodger  
Flies with no bulky frame  
Comes with shade screens

Open Monday-Friday 8:00-4:00  
Saturday by appointment  
**(510) 521-1829**



**2021 Alaska Packer Place  
Alameda, CA 94501  
Grand Marina**



## OYSTER POINT Marina/Park



*A full service marina located in South San Francisco with berthing and guest dockage available*

For information and pricing call  
**(650) 952-0808**  
[www.smharbor.com/oysterpoint](http://www.smharbor.com/oysterpoint)

## CRUISING CATS USA

Your West Coast Dealer for



**BEARCAT 46**

Special intro savings: \$100K LESS than the \$749K price.  
(46' x 18' x 3' - 16-24kts.)  
2,3, or 4 suites. Fully equipped/turn-key ready.



**LAGOON 500**

38' to 62'  
\$350,000 to \$1.5M  
Also L-420 'hybrid', dsl-elec



**MAHÉ 36**

36' to 65'  
\$300,000 to \$1.3M



**GEMINI 105MC**

34' x 14'  
Fully equipped for cruising  
\$169,000

SEE US AT THE SEATTLE BOAT SHOW

California Don Margraf (510) 469-3330  
Pacific Northwest Rod Gibbons (877) 937-2287

[www.CruisingCatsUSA.com](http://www.CruisingCatsUSA.com)



**LIFELINE**  
...the heart of your system II



Made  
in  
U.S.A.

## LIFELINE BATTERIES

**Valve Regulated Lead Acid (VRLA) Batteries**  
**Absorbed Glass Mat (AGM) Technology**

Concorde, a pioneer in AGM technology, was originally developed in 1985 for military aircraft where power, weight, safety and reliability were paramount considerations. This technology was incorporated in the Lifeline series of maintenance-free deep-cycle batteries that has been the leading AGM battery in the Marine and Motor Coach Industry for the past 15 years and is now original equipment in 135 manufacturers worldwide.

Lifeline AGM Batteries are proven to be the fastest recharging batteries today because of low internal resistance. Since there is no free electrolyte in AGM batteries, terminal corrosion is eliminated. They are a completely sealed recombinating gas battery, eliminating the need for water replenishment.

These are some of the reasons that Lifeline Batteries are the safest, fastest recharging batteries today.

To learn more about Lifeline Batteries, visit our web site at:

[www.lifelinebatteries.com](http://www.lifelinebatteries.com)

**Lifeline Battery Inc.**

955 Todd Ave., Azusa, CA 91702 • (800) 527-3224

## KISSINGER CANVAS

*Marine Canvas & Interiors*  
STEVEN KISSINGER  
**(925) 825-6734**  
*Covering the Entire Bay Area*



- Biminis
- Boat Covers
- Cushions
- Sail Covers
- Headliners
- Awnings

## DODGERS

Side handrails and window covers included.

## OPTIONS

Aft handrail, dodger cover, sailing bimini.

*Free Estimates and Delivery*

## LETTERS

*it as quickly as possible. It's true that more than a few people have been killed.*

*Have you ever seen or been hit by a true sneaker wave? If so, email us at [richard@latitude38.com](mailto:richard@latitude38.com).*

### ↑↓ I'VE BEEN LUCKY WITH MY BOAT PARTNERSHIPS

I read Thomas Hill's inquiry about boat partnerships, and wanted to report on my experience. I've been involved in three boat partnerships — a homebuilt boat in Italy, and a Pearson 22 and C&C 29 in the Bay Area. All were done with cash and a handshake. All have worked out very well, especially since I turned out to be the most frequent user of all the boats, which allowed me to enjoy lots of great sailing on Lake Como and off Alameda and Santa Cruz. Maybe I was just lucky, but I don't think you have to get that legal if you have a good feeling about the people you are joining.

Michael Faulk  
Aptos

*Michael — Maybe it's more than just luck. Maybe you and your partners are responsible, easy to get along with, and able to see things from other partners' points of view.*

### ↑↓ KICK SOME LAKE SAILORS' BUTT

It sure seems to me that Larry Ellison and the BMW Oracle America's Cup team has been taking a lot of flak for what no other team seemed to have the huevos to do — and that is stand up to the Swiss rascal Ernesto Bertarelli of *Alinghi*. What he was doing really was B.S., and it did my heart good to see that things didn't go well for them for once. But I also find it appalling that folks aren't giving Ellison and BMW Oracle a standing ovation. Good on ya', BMW Oracle — and kick those lake sailors' butts!

Gary Watson  
Abrejos, Ericson 27  
Olympia, WA

*Gary — You make a good point. Personally speaking, we'd*



V. CURTCHET / DPPI / IDEC

*have been more enthusiastic about BMW Oracle's court victory had we not been suffering from an extreme case of America's Cup Legal Proceedings Fatigue. Furthermore, we're finding it increasingly difficult to get excited over a sailing event where it takes \$150 million to be competitive, where the event's prestige is based primarily on the fact that so many rich guys are willing to spend so much money, and where there appears to be so little regard for the environment. As we've said elsewhere, we think what*

*Francis Joyon is doing is far more admirable in all respects.*

*Francis Joyon is doing is far more admirable in all respects.*

### ↑↓ WING NUTS AND OTHER STUFF

I'm prompted to make several comments concerning the great December issue.

First, on page 48 of *Letters*, the photo of the Santana 22 mast being worked on from the balcony of a house reminds me of the '70s when I was working at Sailboats, Inc., the larger

# PREMIER SLIPS FOR SALE

## Yacht in the Heart of San Francisco Bay

EMERY COVE  
YACHT HARBOR

**BUY A SLIP: Save money & earn equity!** Save 1/3 of your rental cost. Enjoy big tax savings as a slip owner. Emery Cove Yacht Harbor is the only marina on the Bay with FEE SIMPLE dockminium ownership.  
**OR RENT A SLIP: 35-60' slips!** Rates from \$8.00 to \$9.20.

**HAPPY  
NEW  
YEAR!**



**CALL FOR A MARKETING PACKAGE • 510-428-0505**

3300 Powell Street, Emeryville, CA 94608 • www.emerycove.com • Email: info@emerycove.com

**SAVE**

## DISCOUNT MARINE HARDWARE

**New & Used**

Online, ready to ship worldwide

- Line
- Hardware
- Winches
- Outboard Engines
- Carbon Poles
- Spectra Loops
- Pre-made One Design Rigging
- Electronics

**FEATURED  
SPECIAL**

Racing Berths  
Perfect for Pacific Cup

<http://stores.ebay.com/Discount-Marine-Hardware>



**Save money and  
save the planet!**  
Reuse & recycle.

**BOAT SHOW!**



See Zodiac on display  
Alameda Fairgrounds  
Pleasanton • January 4-13



**Cadet  
Fastroller**

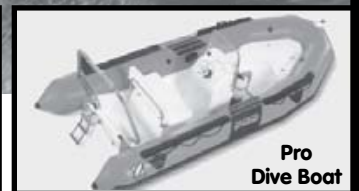

**Pro  
Dive Boat**

- YACHT TENDERS
- PROFESSIONAL DIVE BOATS
- RIBs & ROLL-UPS
- LIFERAFTS
- SALES AND SERVICE



**CALL TODAY FOR LOWEST PRICE OF THE YEAR!**

**Tim's Zodiac Marine**

45570 Industrial Place #10, Fremont, CA 94538

**(510) 438-9881**



**AVON INFLATABLES**





After 25 years as the nation's leading marine outfitter and safety expert, Landfall Navigation is now simply Landfall. We're shortening our name. Expanding our product lines. Issuing more catalogs. Redesigning our website. But one thing endures: our commitment to safety. So whether you need to outfit a dinghy or a maxi yacht, think safety first – think Landfall.

**SAVE \$25**

To celebrate the new Landfall, for a limited time save \$25.00 when you spend \$150.00 or more. Use promotional code EA0101 at checkout to receive your savings.\*



Phone: 800-941-2219 | Online: www.landfallnav.com | On Land: Stamford, CT

\*Not to be combined with any other promotion. Limited time offer expires 1/31/08. © 2008 Landfall Navigation. All rights reserved.

## ELLIOTT / PATTISON SAILMAKERS

### Load Path Membranes now available

Great Sails, Great Service, and Great Prices... Made in our loft in Newport Beach

As Load Path Membrane sail technology continues to develop we are committed to providing the proper solution for your application, whether it is a Load Path, D4, D3, or tri-radial paneled sail.

Call us now for a quote and see how competitive these sails are: both on the race course, and the budget!

**For information:**  
949 645-6697

LA Harbor Area:  
Steve Dair 310 619-7245

Marina Del Rey:  
Doug Johnstone  
310 528-2146

Oceanside: Lee Pryor  
760 529-0062



Antrim 40 "XL"



**The Only Sailloft  
in Newport Beach**  
870 Production Place  
(949) 645-6697  
Newport Beach, CA 92663

## LETTERS

boat dealership in the East Bay. On many occasions we did most work on our boats from the balcony at Quinn's Lighthouse in Oakland. The advantage of that location was that beer was right at hand as soon as our work was completed!

Second, in John Riise's very fine *Diesel Diagnosis* article, he discusses some reasons why a diesel may not turn over.



LATITUDE / ANDY

**What we don't understand is, if wing nuts don't meet ABYC standards, why are batteries sold with them?**

One of my current pet peeves is the use of wing nuts on battery terminals for boats. Indeed, West Marine supplies many of their batteries with wing nuts. However, the American Boat and Yacht Council (ABYC) standard E-10 Storage Battery section reads, "10.8.3 Battery cables and other conductors size 6 AWG (13.3 mm<sup>2</sup>) and larger shall not be connected to the battery with wing nuts." I have seen wing nuts on many of the boat batteries on vessels I have surveyed this year and, in three cases, the engine would not turn over even though the battery cables appeared to be tight. In each case, tightening with a wrench or pliers completed the connection enough so that the engine then started. So please, replace the wing nuts with hexagonal nuts, then torque them properly with the proper size wrench.

Finally, in the letter on page 74 regarding the San Diego



JACK MACKINNON

**We presume that raft-ups aren't allowed at the San Diego Police Dock.**

I was surprised that there was not a bigger raft-up.

Jack Mackinnon, AMS®-SMS  
San Lorenzo

Police Dock, I took this photograph from my room at the Kona Kai Inn on the afternoon of October 27 during the Society of Accredited Marine Surveyors® (SAMS®) annual international meeting. I was surprised

### ↑↓NOT MUCH LEFT OF THE CUTTY SARK

If readers follow your advice to drop by the *Cutty Sark* when in London, they'll be sorely disappointed, for the last of the tea clippers was all but completely destroyed by fire months ago. There are big intentions to rebuild — if the money can be raised.

Nonetheless, as you stated, Greenwich is well worth any sailors' time, regardless. As for the evident 200-ft error in the location of the Prime Meridian reported by your readers, the following may explain it:

You mentioned that the Royal Naval Observatory was established by King Charles II in 1675 to "figure out a way to accurately determine longitude," but it wasn't until an Act of Parliament in 1714 that England got really serious about accurately determining longitude whilst at sea. It was decreed that 20,000 pounds — a few million of today's anemic dollars — be awarded to whomever built a timepiece that, after being



# MODERN SAILING ACADEMY

SAUSALITO, CA

## PREPARE TO TAKE THE HELM



[www.modernsailing.com](http://www.modernsailing.com)

800-995-1668

415-331-8250

### Captain's Special

**Only \$2195!**  
Save over \$500!



#### Includes

- ▲ Modern Sailing Membership
- ▲ ASA One Year Membership
- ▲ Basic Keelboat (ASA 101)
- ▲ Basic Coastal Cruising (ASA 103)
- ▲ Bareboat Chartering (ASA 104)

### Captain's License Course U.S. Coast Guard Approved

This course will prepare you for all elements of the exam. We also guide you through the application process! With **On Site Testing** and **On-The-Water Practicals**, our **pass rate is 100%**. We **Guarantee** it. Convenient night and weekend classes make this course ideal.



Local Instructors and Professional Support!

**6 PAX LICENSE - OUPV, \$995**

February 2 - 23

**100 TON MASTER LICENSE, \$1195**

February 2 - March 2

Sat & Sun (9am to 5:30pm)

Tues & Wed (7pm to 10pm)

**Modern Sailing  
Club Members  
receive \$100 off!**

SEASHINE

## YOUR BOAT DESERVES IT!

Fully Insured & Marina Approved

Polishing • Detailing • Maintenance  
Bilge Cleaning • Washdown  
Carpet and Cushion Cleaning

Call now for a Free Estimate

**510 428-2522 or 415 457-6300**  
[www.seashine.net](http://www.seashine.net)

COVER CRAFT

## An Ode to Dodgers



Order now for summer!

Because Comfort Counts!  
Custom designed to work with  
you and with your boat –  
and with clear windows!

1230 Brickyard Cove Road, #106  
Pt. Richmond, CA 94801  
In Brickyard Cove Marina

**(510) 234-4400**

Quality  
Yacht  
Canvas



# MARINE INSURANCE

Global Coverage • Personal Service  
*Unbeatable experience to match  
 your needs to the right product.*



*Insurance made simple, affordable and effective.*

## TWIN RIVERS MARINE

INSURANCE AGENCY, INC.

7 Marina Plaza, Antioch, CA 94509 LIC # OE32738

[www.boatinsuranceonly.com](http://www.boatinsuranceonly.com) **800-259-5701**

# Wright Way designs

Custom Yacht Interiors

**PROFESSIONAL DESIGN  
 SERVICES INCLUDE  
 CUSTOM**

carpeting  
 cushions  
 designer fabrics  
 draperies  
 linens  
 upholstery



**Deborah Wright**  
**510.908.3939**

2900 Main Street #67, Alameda, CA 94501

[wrightwaydesigns@hotmail.com](mailto:wrightwaydesigns@hotmail.com)

Check out our new web site:

[www.wrightwaydesigns.com](http://www.wrightwaydesigns.com)

# LETTERS

carried from Greenwich to the West Indies and back, could prove accurate to within 30 miles. A piffling couple of hundred feet were probably no big deal back when someone plonked down the line that, by today's nano-technological standards, we expect to be spot on.

Just in case some readers don't know the tale about determining longitude, it took an enterprising amateur John Harrison literally a lifetime to build such a timepiece necessary to determine longitude, and he bettered the required accuracy by 20 miles. A naïve 20-year-old with no clock-making experience when he began the work, he was an old man by the time he accomplished the feat on his fifth West Indian trial.



WEBB LOGG

*After this fire last May, there's not that much left of 'Cutty Sark' to see.*

All the while, he had been jealously observed by professionals from (appropriately) the Royal Observatory. Harrison's trick was to use perpetually self-lubricating *lignum vitae* wood that didn't expand or contract detrimentally with changes in the temperature and humidity. However, he was literally on his deathbed by the time he was actually awarded his prize. There had been a change of heart in Westminster since their navy had their hands on the holy grail of clocks — the one Capt. Cook had already 'borrowed' for his last two voyages. It was only when Harrison's son William pleaded his father's claim all the way up the governmental ladder to King George III that the prize was awarded.

Iain Woolward  
 Krystyna Alicja, Vanguard Finn  
 Redwood City

*Iain — We knew and reported that the Cutty Sark had burned during restoration on May 21 of last year, but had forgotten that she'd been so badly damaged. Thank you for correcting us. Authorities estimate it would cost \$50 million U.S. — about the price of a small apartment in expensive London town — to repair the historic tea clipper. We hope they do.*

*For those who love learning where ships — and whiskies — got their names, 'cutty sark' is, in Scots, a short undergarment. It was also the nickname of the character Nannie in Robert Burns' comic poem 'Tam o' Shanter'. Nannie wore a linen cutty sark that she had been given as a child, so it was much too small for her. But the erotic sight of her dancing in what today would be the equivalent of a thong from Victoria's Secret — caused Tam to cry out, "Weel done, Cutty Sark!" — and it became a popular expression.*

*In a typical month, we receive a tremendous volume of letters. So if yours hasn't appeared, don't give up hope.*

*We welcome all letters that are of interest to sailors. Please include your name, your boat's name, hailing port, and, if possible, a way to contact you for clarifications.*

*By far the best way to send letters is to email them to [richard@latitude38.com](mailto:richard@latitude38.com). You can also mail them to 15 Locust, Mill Valley, CA, 94941, or fax them to (415) 383-5816.*

# Sailors aren't alone



## with an Alpha pilot onboard

**Ultra-Low Power Consumption – Reliable – Accurate**

For 35 years, Alpha has been delivering the reliability, performance and low power consumption offshore sailors have demanded.



**Alpha Marine Systems, Inc.**

Call the quality leader... **1-800-257-4225**

or visit us on the web at **www.alphamarinesystems.com**

### WHY DO BUSINESS WITH SAL'S?

*Your one stop shop  
for  
offshore safety*



- Central Bay Area location
- Broad Product Selection
- Factory and USCG Certified

- Sales
- Service
- Repairs
- Rentals
- Liferrafts

**BOAT  
SHOW  
PRICES**  
in our  
Alameda Office  
Jan. 1 to  
Feb. 15!!

- Inflatables
- EPIRBs
- Flares
- Survival Suits

**SAL'S**  
INFLATABLE  
SERVICES, INC.

PHONE (510) 522-1824

FAX (510) 522-1064

1914 Stanford St., Alameda 94501  
salsinflatables@sbcglobal.net  
www.salsinflatableservices.com

**NEW** Factory Approved for  
**WINSLOW LIFERAFTS**

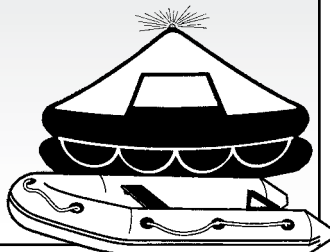

### It's Time to "Fuel-Proof" Your Boat!

A dual filter controller with a built in vacuum/pressure gauge for monitoring the online filter, a built in fuel pump for easy engine bleeding and onboard fuel polishing, along with an early warning panel to let you know when the filter is clogging.

### FilterBOSS

"Don't Leave Shore Without It"

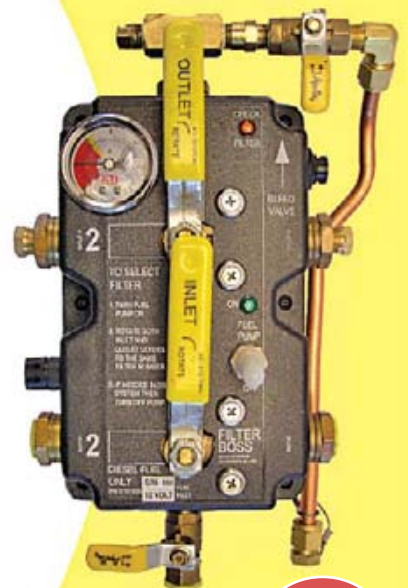

See us at  
Strictly Sail  
St. Petersburg  
& Miami

KTI Systems Inc.

**www.KTISYSTEMS.com**

(800) 336-0315 / Fax (413) 569-6911 / Filterboss@ktisystems.com





greenboatstuff.com

Environmentally Friendly Boating Supplies

- Anti-Fouling Paint
- Fueling Systems
- Sunscreen
- Galley Gear
- Clothing & Linens
- Personal Care Items
- Bags & Buckets
- And Much, Much More!
- Cleaning Supplies

VISIT OUR WEBSITE TODAY!!

www.greenboatstuff.com

or call us toll free at  
(866) 535-1610



## ULTRA SMALL CABIN AND WATER HEATER

### NEW HEATER BREAKTHROUGH

Be comfortable all year round with a quiet, reliable Webasto hot water heating system. Can be linked to pre-heat an engine and provide all the hot water you'll need in the galley or for showers.

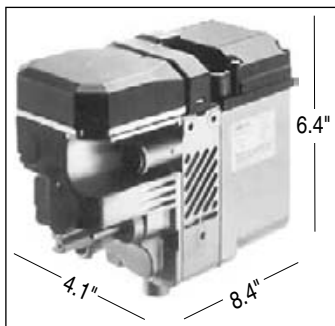

**Webasto**

### CERAMIC IGNITION SYSTEM

- Heat output 17,200 btu/hr (5kw)
- Fuel Consumption .18 gal/hr
- Power Consumption 32 w
- Weight 6.4 lbs

CALL FOR MORE INFORMATION



**SWEDISH MARINE**

1150 BRICKYARD COVE RD., SUITE B6  
PT. RICHMOND, CA 94801 (510) 234-9566

## LOOSE LIPS

### Remembering Phil.

We have been remiss in taking so long to note the passing of historian and cartoonist Phil Frank, who died of complications from a brain tumor on September 12. He was 64. Although sailing was only a small part of Phil's world, he was an integral part of the sailing community, and a large part of what makes the Bay Area, and particularly Marin, such an enclave of idealism and creativity. Most people will know him best through his daily *Chronicle* comic strip *Farley*, where his talent for poking gentle fun at even the most serious of local issues almost always accomplished its goal: to make us laugh at ourselves.

Phil was hugely generous with his time, both as Sausalito's unofficial historian (his lecture on the bootleg days of prohibition was one of our favorites, and the house in which he lived above Caledonia street was once a speakeasy), and with his talent as an artist. He did numerous renderings for us to illustrate stories over the years. His style also became synonymous with the fun drawings he did for BayRisk Insurance's monthly advertisements in *Latitude*. That company was one of many who have paid tribute to Phil in the months since his passing:

*For the last 10 years, Phil Frank captured the spirit of marine insurance needs. The creator of Farley, a nationally syndicated strip The Elderberries, as well several books, Phil was generous with his time and talent. He had been working with John Hardgrove, owner and creative director of the Design Bunch on the BayRisk ad campaigns since 1997.*

*Phil had a love for the water and boats. He lived and worked aboard a Sausalito houseboat for 13 years before moving ashore. As part of the BayRisk campaign, he would use his comic skills to take disastrous boating situations and make them funny. It not only brought readers a chuckle, but focused attention on serious events that happen at dockside as well as on the water.*

*As a tribute to the great work Phil Frank did for BayRisk, plans have been made to run the classic ads from the past 10 years in 2008. Phil provided us years of smiles and we at BayRisk are grateful to have been able to share his creativity and wonderful sense of humor with you all.*

Our belated condolences to the friends and family of Phil. We invite readers to learn more about him and his work at [www.farleycomicstrip.com](http://www.farleycomicstrip.com).

### Why sailboats sink.

Every year, BoatUS thumbs through their insurance statistics to come up with helpful hints on not becoming one — a statistic, that is. Their latest list, culled from a study of 100 sailboat sinkings is titled *Why Sailboats Sink and Five Tips to Prevent It*. Without further adieu, the most common causes of sinkings are...

#### Sinking Underway:

- Struck Submerged Object 40%
- Prop, Shaft or Strut Problem 16%
- Below Waterline Fitting 16%
- Grounding 8%
- Stuffing Box Leak 8%
- Storm/Knockdowns 8%

#### Sinking at the Dock

- Below Waterline Fitting 44%
- Stuffing Box Leak 33%
- Keel/Centerboard Leak 7%
- Rain 7%
- Head Back-Siphoning 3%
- Above Waterline Fitting 3%

Sailboat keels seem to be the main contributing factor in the 'strike submerged object' category, as collision leaks often oc-

# 'TREE HUGGERS' ... NAPA STYLE

Once a year, our entire marina staff goes out and picks olives – one of the perks of being the only boatyard in the state (that we know of) landscaped with mature olive trees.

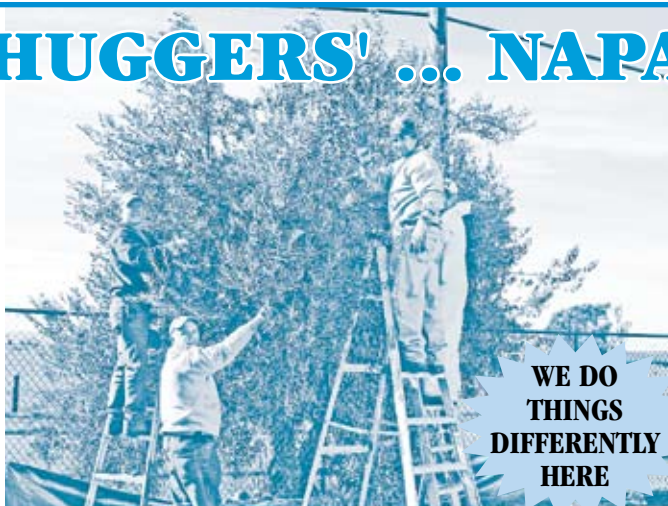

This year we picked about a ton and immediately took them to press. The result was 32 gallons of the finest extra, extra virgin olive oil ever produced by a boat yard.

So call us today regarding that winter project, our unmatched dry storage, or if you just want to talk olive oil.

## CELEBRATING OUR 50<sup>TH</sup> ANNIVERSARY

### NAPA VALLEY MARINA

1200 Milton Road • Napa, CA 94559

(707) 252-8011 • Fax (707) 252-0851

[www.napavalleymarina.com](http://www.napavalleymarina.com)

Marina • Boatyard • Chandlery • Brokerage

Dealers for

**YANMAR**

**Interlux**  
yachtpaint.com

Distributors for *Brownell*  
Boat Stands

### DRY STORAGE

\$3.75/ft

Power & Sail

**REPAIR REPAIR REPAIR**

**CRUISERS' REPAIRS**  
**FAST TURNAROUND**  
**RACING REPAIRS**

**YOUR ROLLER FURLER UV COVER SPECIALIST**

**ROOSTER SAILS**

451 West Atlantic Ave., Alameda Pt. (Alameda Naval Air Stn.)  
**(510) 523-1977**

[www.roostersails.com](http://www.roostersails.com) • [rui@roostersails.com](mailto:rui@roostersails.com)

Open M-Th 9-6 • Fri 9-5 • Sat by appt.

Owned and Operated by Rui Luis • Experienced Sail Repair and Fabrication

**NOW OFFERING NEW CRUISING SAILS!**

**SAIL REPAIR SPECIALISTS • COMPETITIVE RATES • RECUTS • CONVERSIONS**

## OFFSHORE INSURANCE

For Canadian, U.S., & International Registered Vessels

Policy Underwritten through Lloyds, London Underwriters

**SEE US AT THE SEATTLE BOAT SHOW**

**Dolphin**

Tel: (604) 261-9200 Fax (604) 484-2311

**Call Toll Free 1-800-460-0619**

Apply online at: [www.dolphininsurance.com](http://www.dolphininsurance.com)



**HONDA**  
**MARINE**  
IT'S ALL ABOUT POWER.

**caribe**  
INFLATABLES

**Aquapro**  
INFLATABLES



**TOHATSU**  
outboards

**Achilles**

We've been **THE Bay Area** authority for  
inflatables and outboards for more than 35 years.

Call us today for quotes.

**Voyager Marine**

1296 State St.  
P.O. Box 246, Alviso, CA 95002-0246  
**(408) 263-7633 • (800) 700-7633**  
Open Tuesday thru Saturday



**SAUSALITO**



**LIST MARINE INC.**

- Full service engine shop
- We service all makes
- Dockside facilities
- Mobile service trucks



**YANMAR**  
marine

P.O. BOX 2008 / 69 LIBERTY SHIP WAY  
SAUSALITO, CA 94966  
Adjacent to Schoonmaker Pt. Marina

**415•332•5478**

## LOOSE LIPS

cur around where the keel attaches to the boat. Collisions with submerged objects can also nick a prop, bend a shaft or loosen a strut or rudder, too. Also, sailboat engines get less use (compared to powercraft engines), which invites more corrosion damage.

BoatUS's suggestions for staying afloat:

- Any time the boat hits anything in the water, immediately inspect the bilge and keelbolts, or centerboard and associated structures, for damage. To be safe, inspect everything again an hour later.

- Routinely — twice a season — inspect all below-waterline fittings, hoses and hardware. If the fitting is long enough and it hasn't been done already, it's good practice to have *two* marine-rated stainless steel hose clamps on all hose ends. As well, any hoses showing signs of rot should be replaced immediately.

- Underway, stuffing boxes are supposed to leak a little bit — a drop every 10 to 30 seconds. When at rest, stuffing boxes should *not* leak. If yours does, tighten or replace the packing.

- Don't ignore thru-hull fittings or hoses installed above the waterline. While they may appear to be 'safely' above the water level, they can leak when the boat heels over or — in really cold climates — when snow or ice buildup pushes the boat deeper in the water.

**Hey buddy, wanna buy a nice prop?**

There are rumors going around that boats stored in dry storage yards are being relieved of props and in some cases winches. One tipster who did not want to be identified says the propeller was stolen off his boat in a north Bay dry storage facility — "And when I looked around, there were bare shafts all over the place."

Short of removing the propeller after every sail, there's not a lot boaters can do to deter a thief with a big wrench. But we do suggest vigilance with companionway locks and even suggest securing your expensive Edson steering wheels with chain/padlocks or bicycle locks, as some of them have apparently been walking off, as well. If anyone knows more details about these thefts, please let us know.

**The winter of '54.**

With a whole new breed of large, cutting-edge boats prowling the globe, sailing records are once again falling like bowling pins on league night, and the dawn of yet another new era in sailing is upon us. With an equally shiny new year in our laps, we figured it was worth a quick look back for a little perspective.

For beginners, modern sailors aren't the only ones who covet records. In the 19th century, particularly around the time of the clipper ships, speed records were so prestigious that one Captain had his record carved into his tombstone with the addendum 'never beaten'. Then, as now, two of the biggies were the 24-hour ("day's run") mark and top speed. Until about 20 years ago, those records were held by two clippers who set them on runs to Australia in 1854. From noon to noon on December 10-11, the 252-ft *Champion of the Seas* reeled off 465 miles on her maiden voyage from Liverpool to Melbourne. Earlier in the year, another Donald McKay-designed ship, the 245-ft *Sovereign of the Seas* hit 22 knots while running her easting down to Australia.

Those marks are enviable even today. Although both were broken in the 1980s, and have since been eclipsed by every new generation of high-tech craft, it's worth remembering that *Champion* and *Sovereign's* records stood for more than 100 years, and that they were set by fully loaded merchantmen drawing more than 25 feet and sailed by crews of 60 or more. They had no electronic navigation, no weather routers, no ball bearing blocks, no winches and no synthetic lines or sails. They sailed when they had to, not when they wanted to. And only rarely did the weather cooperate to secure them a footnote in history.



## Welcome to YRA Racing!

Thank you for participating in the YRA! We offer you a choice for racing both on the Bay and on the local ocean!

### FLEET INFORMATION

#### HDA (Handicapped Divisions Association)

- Bay Racing on longer courses for boats with a current NCPHRF rating. The Vallejo, 2<sup>nd</sup> Half Opener, and Season Closer Regatta's are included in the HDA Season Racing fee.
- Divisions are determined by grouping similarly rated boats. If you are unsure of your division, please write your NCPHRF rating on the "Fleet" line.
- HDA divisions are invited to race in the Crewed Lightship 1 race for an additional \$5.00 per racer. A signed Minimum Equipment List must be included with entry. Entry into the Crewed Lightship 1 race must be made at the time of season entry or individual race fees will apply.

#### ODCA (One Design Class Association)

- Short Course, Windward/Leeward style racing for qualified one-design classes.
- The Vallejo, 2<sup>nd</sup> Half Opener, and Season Closer Regatta's are included in the ODCA Season Racing if the individual class has included the races on their race schedules. Current Fleet schedules can be found on <http://www.yra.org>
- If you are not sure if your fleet is a current ODCA fleet, or would like to sign your fleet up for ODCA, please contact the YRA office at (415) 771-9500 or [info@yra.org](mailto:info@yra.org).

#### OYRA (Offshore Yacht Racing Association)

- Approximately 12 ocean races ranging from 15 to 51 nautical miles in length
- OYRA racers are invited to race in the Vallejo race for an additional \$5.00 per racer. Entry into the Vallejo race must be made at the time of season entry or individual race fees will apply.
- Racers will race in one of the following 5 divisions, determined by their boats D/L ratio (unless choosing to race in the SHS division):
  - PHRO 1a – NCPHRF of 0 or less
  - PHRO 1 - OVER 31.5 Feet, D/W ratio Less than 200
  - PHRO 2 - OVER 31.5 Feet, D/W ratio 200 & over
  - MORA – 31.5 Feet & Under
  - SHS – Shorthanded division, Specifically Requested

#### WBRA (Wooden Boat Racing Association)

- The WBRA is a Golden Anchor member in US Sailing and includes US Sailing membership dues in its entry fee
- Bay racing for one of the following 4 fleets:
  - Bird Boats
  - Folkboats
  - IODs
  - Knarrs

#### BACK FOR ANOTHER GREAT YEAR!

#### THE YRA PARTY CIRCUIT!



- This series highlights the 3 marquee YRA events: The YRA Season Opener (The Great Vallejo Race) in May, the YRA 2<sup>nd</sup> Half Opener in July, and the new YRA Season Closer in September. Three fun-filled weekend events with great parties on each Saturday night!
- Series Champions will be awarded at the YRA Year-End Trophy Party in November 2008.
- There is one throw out race for the series. In addition, 50% of the fleet or class must qualify for awards to be given.
- All Bay-Area sailors are invited to sign up! We will have divisions for PHRF racers, One-Design Classes and new for 2008, a Double/Singlehanded Division, and a non-spinnaker division. If your One-Design Fleet is interested in signing up, please contact the YRA office.
- When entering, simply list your NCPHRF rating on the "Fleet" line, or, enter your One-Design Fleet.
- Sailing Instructions for each race will be available on the YRA Website: [www.yra.org](http://www.yra.org). If you have any additional questions, contact the YRA office at (415) 771-9500 or [info@yra.org](mailto:info@yra.org).

### GENERAL INFORMATION

- **YRA Sailing Instructions are available on the YRA website at [www.yra.org](http://www.yra.org)**, or at the YRA office. Sailing instructions are normally posted approximately 2 weeks prior to the race for each charter association. If you do not have access to the internet and need to have your race instructions mailed to you, please contact the YRA office at (415) 771-9500 or [info@yra.org](mailto:info@yra.org)
- A YRA sailing membership and a membership in a YRA member yacht club is required to register a boat for any YRA regatta.
- Please fill out your entry form completely, sign, date and return it to the YRA office along with your payment. If you need additional assistance completing this form, please contact the YRA office.





# Yacht Racing Association of San Francisco Bay

## 2008 Entry Form

New for 2008 - Save time and paper!  
sign-up online at [www.yra.org](http://www.yra.org)

Quarters 35 S, Fort Mason  
San Francisco, CA 94123  
Phone: 415.771.9500  
Fax: 415.276.2378  
email: [info@yra.org](mailto:info@yra.org)

Name: \_\_\_\_\_ Boat Name: \_\_\_\_\_ Sail Number: \_\_\_\_\_  
 Street: \_\_\_\_\_ Boat Model: \_\_\_\_\_  
 City, State, Zip: \_\_\_\_\_ Manufacturer: \_\_\_\_\_ Yr Built: \_\_\_\_\_  
 Evening Phone: \_\_\_\_\_ Daytime Phone: \_\_\_\_\_ Designer: \_\_\_\_\_ Yr. Designed: \_\_\_\_\_  
 Email Address: \_\_\_\_\_ U.S. Sailing #: \_\_\_\_\_ YRA Member #: \_\_\_\_\_  
 Yacht Club Affiliation: \_\_\_\_\_ Marina: \_\_\_\_\_ Berth/Slip #: \_\_\_\_\_

<b>Membership Fees:</b>	YRA Membership: <b>Required for YRA Racing</b>	\$40	\$ _____
<b>NCPHRF Fees:</b>	Renewal of 2007 Certificate:	\$30	\$ _____ <i>Please attach NCPHRF</i>
	New Certificate or Renewal of 2006 or prior Certificate:	\$40	\$ _____ <i>renewal form or application</i>

<b>Season Racing Fees:</b>	<b>US Sailing Members</b>	<b>Non US Sailing Members</b>	<b>Fleet</b>	<i>See back for more fleet information</i>
Handicap Division Assoc (HDA) Season <i>(6 Race Days only, Does not Include Vallejo, 2nd Half Opener or Season Closer)</i>	\$120	\$135	_____	\$ _____
HDA Season + Party Circuit (12 race days)	\$180	\$195	_____	\$ _____
YRA Party Circuit <i>includes Vallejo, 2nd Half Opener and Season Closer only</i>	\$120	\$135	_____	\$ _____
One Design Class Association (ODCA) Season	\$180	\$195	_____	\$ _____
Ocean Yacht Racing Association (OYRA) Season *	\$195	\$210	_____	\$ _____
Wooden Boat Racing Association (WBRA) Season <i>(includes US Sailing Membership)</i>	\$190	N/A	_____	\$ _____

<b>Single Race Fees:</b>	<b>US Sailing Members</b>	<b>Non US Sailing Members</b>	<b>Fleet</b>	<i>See back for more fleet information</i>
HDA season racers entering Lightship 1 *	\$5	N/A	_____	\$ _____
OYRA season racers entering Vallejo	\$5	N/A	_____	\$ _____
Vallejo Race Only (YRA Season Opener)	\$75	\$80	_____	\$ _____
2nd Half Opener Only	\$75	\$80	_____	\$ _____
Drake's Bay *	\$75	\$80	_____	\$ _____
All other YRA Races (write in race name): _____	\$50	\$55	_____	\$ _____

<b>Racing Late Fees:</b>	<b>1st Deadline</b>	<b>2nd Deadline</b>	
Vallejo Race (YRA Season Opener): 1st deadline- 4/21, Final deadline- 4/30	\$35	\$75	\$ _____
Lightship 1: 1st deadline- 3/10, Final deadline- 3/19	\$35	\$75	\$ _____
All other YRA Races: Rec'd after 5pm Mon and before 5pm the Wed before race	\$35	N/A	\$ _____

**No entries accepted after 5pm the Wednesday before the race**

\* All YRA Racers entering an ocean race or ocean series must submit a signed OYRA Minimum Equipment Requirement List. See [http://www.yra.org/OYRA/ocean\\_safety.html](http://www.yra.org/OYRA/ocean_safety.html) or contact the YRA office for more information.

**TOTAL** \_\_\_\_\_

In consideration of being admitted to sailing membership in the Yacht Racing Association of San Francisco Bay (YRA), I agree to abide by "The Racing Rules of Sailing" and the Sailing Instructions of the YRA and the regatta sponsors. I warrant that I will maintain compliance with the YRA Minimum Equipment requirements. I agree to release the officers, agents and employees of the YRA, and its member Associations in any activity to which this entry form applies. I further warrant that I have not relied upon any of the above entities or individuals in preparing my yacht for racing.

Signed: \_\_\_\_\_ Date: \_\_\_\_\_  
 Make check payable to YRA. To pay by MasterCard or Visa please provide card info below, including billing street address and zip code

Card Number: \_\_\_\_\_ Exp Date: \_\_\_\_\_ CV # \_\_\_\_\_ Name on Card: \_\_\_\_\_

Card Holder's Signature: \_\_\_\_\_ Billing Address: \_\_\_\_\_

<b>Office use only</b>			
C.C.	Check Number _____	Amount PD _____	DATE Received in office _____





## TRY IT... YOU'LL LIKE IT!

*The Bay Area  
Racing Scene  
has something  
for everyone.*

**What boats?** Here's a start: Catalina 30, Flying Dutchman, Pearson Triton, Islander 36, J/105, Optimist, Ranger 33, Olson 25, Beneteau 36.7 – really, the list is endless. If you own a sailboat there's an event for you.

**Where?** Everywhere: the South Bay, inland, fresh-water lakes, the ocean, the central Bay. You shouldn't have to venture far from your slip to find a starting line.

**When?** You can pick a couple of fun events or practically race every day of the week, with casual 'beer can' racing Monday-Friday, the three-weekend 'Party Circuit', special events, and season-long series.

**Who?** How about you! You can race singlehanded, doublehanded, with a full crew, women skippers, kids' events, one design or open class.

**Why?** You'll use your boat more, have more fun, meet new people, improve your skills, and discover things about the Bay, your boat and sailing you never dreamed of. Why not?

## BUT HOW?

- **Pick up** one of these:
- **Pick out** the fleet or events you want to sail in
- **Fill out** the form on the left
- **Save the dates** and go sailing!



## NEED CREW?

**Go to** [www.latitude38.com](http://www.latitude38.com) and use our **free** online Crew List. Then come to our Crew List Party on Wednesday, April 3, 6-9pm at Golden Gate Yacht Club on the San Francisco Marina.



# South Bay Yacht Racing Association

## 2008 RACING CALENDAR

### 2007-2008 WINTER SERIES

January 5	Winter #3	Oyster Pt. YC
February 2	Winter #4	Coyote Pt. YC
March 1	Winter #5	Sequoia YC

### SUMMER SERIES

April 12	Summer #1	Sierra Pt. YC
May 3	Summer #2	Oyster Pt. YC
June 7	Summer #3	Bay View BC
July 12	Summer #4	Ballena Bay YC
August 2	Summer #5	San Leandro YC
September 6	Summer #6	Coyote Pt. YC
October 4	Summer #7	Coyote Pt. YC

### 2008-2009 WINTER SERIES

November 1	Winter #1	Oyster Pt. YC
December 6	Winter #2	Sierra Pt. YC

*For information call Larry Westland*

**(510) 459-5566**

[lwestland@tricommercial.com](mailto:lwestland@tricommercial.com)

<http://sbyra.home.comcast.net>





# SIGHTINGS

## **miss catarena**

Bay Area photographer Peter Lyons captured these fantastic shots of the lovely catboat *Catarena* during a sail on a fine December day. *Catarena* was built in 1917 at the Crosby Shipyard in Cape Cod. She originally worked as an oyster dredger up and down the Eastern Seaboard, dragging rakes through the sandy bottom, even in the lightest of wind.

At some point, *Catarena* was acquired by the Los Angelean who donated her to the San Francisco Maritime National Historic Park last June. She's currently under the care of Christian Buhl — who can

continued on outside column of next sightings page

## **darla jean wrecks**

In the December 5 *Electronic Latitude*, we reported that the disabled San Francisco-based 47-ft motorsailer *Darla Jean* wrecked on a reef at Fanning Atoll on December 2 after two and a half months drifting across the Pacific. Owners Darla and Jerry Merrow — and their dog and macaw — were reported by Robby and Lorraine Coleman (who've been on Fan-



PHOTOS PETER LYONS / WWW.LYONSIMAGING.COM

## on fanning atoll

ning for several months aboard their Honolulu-based Anglemann ketch *Southern Cross*) to be in good physical condition and requesting no assistance, even though *Darla Jean* was a total loss.

We were naturally curious about the couple, so we asked if anyone knew them. Over the next few days, we received emails

continued in middle column of next sightings page



**Catting around** — *'Catarena'* will often be seen next summer at Hyde Street Pier, taking kids out for daysails.

## catarena — cont'd

often be seen on the Bay at *Catarena's* helm — and will soon become a 'frequent flyer' in the Park's community sailing programs. For more on those programs (many of which are for kids), contact the Park's Education Director M.J. Harris at [mjharris@maritime.org](mailto:mjharris@maritime.org).

— ladonna

## francis joyon — our sailing hero

Potentially the greatest sailing achievement since we started covering sailing 30 years ago? We think so. We're referring to Frenchman Francis Joyon's assault on Ellen MacArthur's 71-day solo around-the-world record — and, although Joyon never intended it, a run on Bruno Peyron's crewed Jules Verne-around-the-world record of 52 days with the 125-ft cat *Orange II*.

If you've been following our extensive coverage of Joyon's adventure in *'Lectronic Latitude*, you know he's racing around the world aboard *IDEC*, his new 97-ft Irens/Caberet trimaran. As we write this on December 20th, Joyon has passed the halfway mark of the circumnavigation, and is already 2,800 miles ahead of MacArthur's pace — and that doesn't take into account the fact that MacArthur came down with a terrible case of the slows coming up the Atlantic.

Although you may not be too familiar with the 51-year-old Joyon because, unlike most French superstar sailors, he's not interested in the spotlight, he's hardly new to tremendous sailing records. In '04, sailing Olivier de Kersauson's handed-down 92-ft trimaran *Sport Elec*, renamed *IDEC*, with 10-year-old sails and no weather router, Joyon set a solo around the world record of just under 73 days. In doing so, he beat the old mark by 20 days. Then, in '05, after MacArthur, backed by a huge team and sailing the new purpose-built 75-ft trimaran *B&Q Castrorama*, nipped his record by a little more than a day, Joyon established a fantastic new solo TransAtlantic record of 6 days, 4 hours, setting a new 24-hour solo record of 543 miles in the process. Exhausted after the record run, Joyon tragically fell asleep while singlehanded *IDEC* back to France, and piled her up on the rocks off the Breton Coast. She was completely destroyed.

When Joyon started his current record run, it was hoped there would be a head-to-head duel between him and Thomas Coville aboard the other Frenchman's new 105-ft trimaran *Sodebo*. Although both trimarans were designed by Irens/Caberet, they are quite different. *IDEC* is eight feet shorter and doesn't have a rotating mast, both of which would seem to be disadvantages. But she's a ton lighter, which would seem to be a big advantage in many conditions. Typical of Joyon, *IDEC* is — unlike *Sodebo* — spartan and short on creature comforts. For example, when it came to staying warm in the Southern Ocean, where there was always fog and the temperature was always in the high 30s and low 40s, Joyon relied on three layers of polar fleece rather than a heater to stay warm. Coville's trimaran, on the other hand, has a nice pilothouse and engine-generated heating. Unfortunately, there was a breakdown in the hydraulic system of Coville's much more complex tri, and *Sodebo* was unable to begin with *IDEC*.

Joyon started astonishingly fast, rocketing down to the equator. And it wasn't long before he set a new 24-hour solo record of 616 miles. To put that in perspective, it's only 450 miles from San Francisco to San Diego. And when the wind went light, Joyon's average speed plummeted to 'only' 15 or 16 knots. As it turned out, Joyon didn't just start fast — he's maintained an incredible pace to where he is as we write this, halfway done with the 28,000-mile circumnavigation. At this stage, he's improved on MacArthur's time by about 30%, and he managed to sail across the entire Indian Ocean less than an hour slower than Peyron and his team aboard the 125-ft *Orange II*. It's astonishing what he's accomplished already.

continued on outside column of next sightings page



# SIGHTINGS

## joyon — cont'd

It's also interesting to note how different an experience Joyon is having from the one MacArthur had. For MacArthur, the solo circumnavigation was an incredible mental and physical battle, one she admits she still hasn't fully recovered from. Joyon, on the other hand, seems to be enjoying himself to no end. Consider the following report from deep in the Southern Ocean.

"The wind comes from the southwest at around 20 knots, and it also brings squalls with enormous black clouds full of rain and strong winds that all arrive in one fell swoop. There are always a lot of birds, a mix of albatrosses and smaller ones, plus the beautiful light. It's really a great day. This morning there was a five-metre swell, but the wind has eased and turned, and now it is a little quieter. So I must adapt. It's been really interesting sailing since . . . I was going to say since yesterday, but it's been interesting since I set off!"

Is this guy in his element or what?

It makes a difference to us that Joyon's assault on the record is a 'green' one, meaning that he insisted on relying on alternative energy sources, rather than an engine or generator, to power his boat's system. "It's working

really well," Joyon told *The Daily Sail*. "Having diverse energy sources is great for safety, too. So often you can be at the mercy of engine failure, and be forced to give up. But wind energy — it's worked perfectly — has given me about 70% of the energy I need for the instruments on board, while the solar panels have done the rest. They operate even in overcast conditions and, at the moment, I've been having daylight for 20 hours each day. I do have a fuel cell as a backup, but so far I've only used four litres of methanol. It's nice to be in tune with the environment as, down here in the Southern Ocean, it's all clean. You see not a trace of waste bags, plastic, bottles — nothing but ocean."

If one was looking for a sailing hero, you'd want him or her to be mentally and physically strong, capable of handling both tremendous success and adversity with equanimity, and be truly in love with what he/she does. Well, we give you Francis Joyon, our sailing hero. We wish him the best of luck for the second half of his great attempt at the record for a solo circumnavigation.

— richard

## lost on a reef at rangiroa

"Having come upon your publication by way of Google," writes self-described 'old salt' Tom Tamburrino, "can you tell me what happened to actor Sterling Hayden's 97-ft schooner *Wanderer*? There are hundreds of references to her, but none of them answer the question of what happened to the schooner after Hayden owned her."

To give a little background, *Wanderer* was built by San Francisco's Union Iron Works in 1893 for John D. Spreckels of the sugar family, and had been christened *Grace S.* after one of Spreckel's daughters. During the Hayden years, *Wanderer* was skippered by Omar Darr, father of Bob Darr, who now runs the Arques Boatbuilding School in Sausalito. The senior Darr bought and sailed the schooner with Joe Price in 1961, then sold his share to Price in '64, who hired Capt. Bill King to run her.

According to Bob Darr, *Wanderer* was tragically lost on a reef at

continued on outside column of next sightings page

## darla jean

from Darla's sister, Kimberly Corcoran, and son, Steve Cliché, filling in some of the blanks in a fascinating story.

"They left San Francisco on a different boat but hit a bad storm just outside of the Gate," said Kimberly. "They made it as far as Monterey when something happened to their keel. That's where they decided to buy *Darla Jean*."

According to Steve, a Navy vet just returned home to Arkansas from Iraq, Darla and Jerry had very little sailing experience

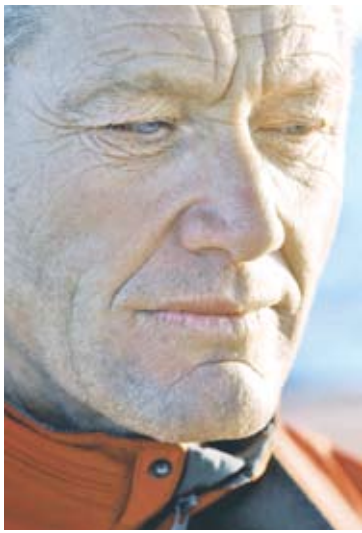

VINCENT CURUTCHET / DPPI / IDEC

"I do my job as a sailor, that's all." The modest Joyon is a sailor's sailor.

Despite the solitude and rigors of sailing solo around the world, Joyon's state of mind has been described as "serene."





## — cont'd

before setting off on their dream voyage. "Everyone told them to wait until they knew what they were doing," he recalled, "but 'The Skipper' insisted everything would be fine." In preparation for the trip to their ultimate destination of the Cook Islands, the couple built what Steve refers to as an "upper floor" out of 2x4s and plywood on what he believes was a trimaran (he never saw *Darla Jean*).

Darla contacted her sister just before  
continued in middle column of next sightings page

*wanderer* — cont'd

Rangiroa on the night of November 7, 1964. King was considered to be a competent skipper who had just been unlucky that night. Sailing, it must be added, was considerably more risky back then, as GPS hadn't been invented, and radar and other electronics weren't what they are today.

If anybody knows any further details of the loss of *Wanderer*, we — and our readership — would be interested to hear them.

Newer generations of sailors may not be familiar with Sterling Hayden and *Wanderer*, but they should be, for Hayden was a bold and larger-than-life figure. He was born in New Jersey, and his father died when Sterling was only nine, at which time he was adopted and took

continued on outside column of next sightings page



JEAN MARIE LIOT / DPPI / IDEC



# SIGHTINGS

## *wanderer* — cont'd

on his new father's last name. During his youth he lived all over the eastern United States, and his moving around didn't change much

continued on outside column of next sightings page

## *darla jean*

leaving Monterey on September 20 and that's the last anyone heard from them . . . until they washed up on Fanning



DIANE BEESTON

## — cont'd

Island, more than 1,700 miles north of their original destination. "It had been

continued in middle column of next sightings page

*This 1964 photo of 'Wanderer' was taken just weeks before she wrecked on a reef in Rangaroa.*

*wanderer* — cont'd

once he was an adult. A true adventurer, Hayden ran away at 17 to be a ship's boy, fished the Grand Banks, got his first command at the tender age of 19, and reportedly circumnavigated several times.

Somehow the 6'5" Hayden became a print model and then an actor. Dubbed "the most beautiful man in the movies" during World War II,

he became an undercover agent with what was to later become the Office of Strategic Services. He also served in the marines, running guns through German lines to Yugoslav partisans, and parachuting into fascist Croatia. He lived a life that was truly more exciting than the movies he starred in.

Hayden returned to Hollywood after the war. He claimed to dislike the profession, and said that he only acted in order to get the money necessary to buy and maintain sailboats. His most notorious exploit was, after losing a bitter custody battle in '59 for his children Christian, Dana, Gretchen and Matthew, defying a court order by taking off with the kids to Tahiti aboard *Wanderer*, with the likes of Spike Africa as crew.

In the early '60s, Hayden rented one of the pilothouses in the old ferryboat *Berkeley* docked in Sausalito — which, at the time, was a pretty interesting place. While there, he wrote *Wanderer*, a biography that all sailors should read. Although he later bought a canal barge in the Netherlands, and ultimately lived aboard her in the heart of Paris, he died in Sausalito of prostate cancer in '86 at age 70.

To our thinking, Hayden's best movie role was that of Colonel Jack D. Ripper in *Dr. Strangelove, Or How I Learned to Stop Worrying and Love the Bomb*. We saw that movie at the Elmwood Theatre in Berkeley in '64 while in high school, and can still remember laughing like crazy as the skeptical Jack D. Ripper machine-gunned a Coke machine to get a nickel to (indirectly) protect the precious bodily fluids of all Americans. Hayden's best writing is the oft-quoted passage from his autobiography *Wanderer*:

"To be truly challenging, a voyage, like a life, must rest on a firm foundation of financial unrest. Otherwise, you are doomed to a routine traverse, the kind known to yachtsmen who play with their boats at sea — 'cruising,' it is called. Voyaging belongs to seamen, and to the wanderers of the world who cannot, or will not, fit in. If you are contemplating a voyage, and you have the means, abandon the venture until your fortunes change. Only then will you know what the sea is all about.

"I've always wanted to sail to the South Seas, but I can't afford it.' What these men can't afford is *not* to go. They are enmeshed in the cancerous discipline of 'security'. And in the worship of security we fling our lives beneath the wheels of routine — and before we know it, our lives are gone.

"What does a man need — really need? A few pounds of food each day, heat and shelter, six feet to lie down in — and some form of working activity that will yield a sense of accomplishment. That's all — in the material sense, and we know it. But we are brainwashed by our economic system until we end up in a tomb beneath a pyramid of time payments, mortgages, preposterous gadgetry, playthings that divert our attention from the sheer idiocy of the charade.

"The years thunder by. The dreams of youth grow dim where they lie caked in dust on the shelves of patience. Before we know it, the tomb is sealed.

"Where, then, lies the answer? In choice. Which shall it be: bankruptcy of purse or bankruptcy of life?"

— richard



*Hayden was once called the "most beautiful man in the movies."*



# SIGHTINGS

## getting a cruising cat the hard way

Coloradan Jim Milski has spent his entire working life in the construction industry. So when he was toying with the idea of building his own cruising catamaran, he figured, "How hard can it be?" Having finally launched *Sea Level* last month after two long years



Jim and Kent Milski.

of laying-up, glassing, shaping, casting, installing and painting, he admitted, "It turned out to be the toughest thing I've ever done, and I couldn't have done it if I hadn't had help."

Luckily, he did have a lot of help. In fact, the long list of professionals who played key roles in the project reads like a Who's Who of the West Coast boating industry — far too many to list here. (See the website [www.levelmarine.com](http://www.levelmarine.com) for a complete list and a wealth of construction photos.) Plenty of non-professionals pitched in too, including

his son Evan and daughters Samar and Alex — and, most importantly, his wife Kent, who was amazingly supportive throughout the project: "She actually said, 'Don't worry about the money.'"

Jim's first sailing experience was in 1980, when a couple of friends took him sailing on a Hobie 16. Despite getting launched right through the jib, he claims, "from that moment on I was hooked." Soon afterwards he got hold of a Catalina 16, which he and Kent used to hone their skills — through trial and error — on 8,600-foot-high Lake San Cristobal. Years later, a family charter out of Key West fueled the couple's cruising dreams, and they eventually bought a Privilege 39 in St. Martin in 1995. That boat's performance was a bit disappointing, however, which led to the notion of building a performance cruiser from scratch.

After exhaustive research, Jim settled on a design by Brett Schionning of Australia. Before fully committing to the project, though, he sought the advice of both retired engineer Blair Grinols, who'd custom-built the 45-ft *Capricorn Cat*, and *Latitude 38* publisher Richard Spindler, who'd overseen the design and construction of the 63-ft cat *Profligate*. They both sincerely tried to talk Jim out of taking on such a daunting project, but he was determined. He flew to Australia, where he picked the brains of 16 boatbuilders. A daysail aboard a Schionning 33 — during which they hit 17 knots — sealed the deal. Jim flew home with a complete set of plans, having placed an order for the hull materials to be shipped out by freighter. Next, Jim and Kent moved to the Bay Area and began searching for a build site, eventually renting a WWII-era Quonset hut on Mare Island.

Fast forward to the present and you'll find the couple eagerly anticipating a sea trial, having recently stepped their custom-built Ballenger spar. With retractable daggerboards and 35 inches of bridgedeck clearance, *Sea Level* is expected to point higher than most production cats and ride well over ocean swells. Now that the untold hours of labor are behind them, the Milskis can refocus on their original goal: to go cruising! We have a strong hunch that *Sea Level* will be on the starting line of Baja Ha-Ha 15 next October.

— andy

## crew list time

Say, hypothetically, that Tom Cruise and Penelope Cruz get back together and decide to go sailing to, oh, Santa Cruz. They could do so by taking part in our spring Crew List. And then we could title an

continued on outside column of next sightings page

## darla jean

over two months since I'd heard anything from them, and the whole family was worried," Kimberly said. "I emailed the Coast Guard to see if they could give me info on their whereabouts and was sent a link to your story. We're all so thankful to know that they are safe!"

According to sketchy reports from Fanning, it appears *Darla Jean* had problems after leaving Monterey that left her unable to either sail or motor. As such, she ap-

PHOTOS COURTESY SEA LEVEL



## — cont'd

parently “drifted” across the Pacific until reaching the reef on the southeast side of Fanning. Once ashore and in the hands of Immigration (Jerry had reportedly lost his passport), the couple made it clear they didn’t want any outside help. They stayed on the island until December 14, when they left on an inter-island steamer bound for Christmas Island. Strangely, none of Darla’s family has yet to hear from her.

— *ladonna*

## crew list — cont'd

article about it “Cruise/Cruz Cruise Crew List for Cruising Boat to Santa Cruz.” Hey, it could happen.

Or not.

Anyway, welcome to the leaner, cleaner Crew List — the place and time of year where we solicit sailors of all ages, genders and interests to sign up for something new this coming year. It used to be this write-up was accompanied by forms that you’d cut out, fill in and mail to us in the categories of Cruising, Racing, Daysailing, Co-Chartering and Boat Swapping. Now that we’ve conceded this internet thingie might actually be around for awhile, we’ve gone completely electronic on

continued on outside column of next sightings page

*It took blood, sweat and tears — not to mention two years — but ‘Sea Level’ was finally launched last month*





# SIGHTINGS

## crew list — cont'd

the Crew List forms. You will no longer find them — or the resultant lists — in the magazine, but can access them anytime 24/7 by going to [www.latitude38.com](http://www.latitude38.com) and clicking on the 'Crew List Forms' link.

Doing it this way, an independent lab has confirmed, means *Latitude* uses a couple rainforest acres less paper, has lowered our collective blood pressure at least 20 points and emits far fewer hydrocarbons into the atmosphere. Darned if this thing hasn't turned into the downright Prius of Crew Lists.

continued on outside column of next sightings page

## pucker

In the Coast Guard, 'Surfman' carries the same connotation as Army Ranger or Navy Seal — an elite few who can go out in conditions like this and not only save other people's lives but, most of the time, retain their own. This spectacular sequence by photographer Gary Robertshaw shows a 44-ft motorlifeboat conducting Surfman training outside Morro Bay on



PHOTOS GARY ROBERTSHAW

## factor 10

December 4. The first photo (inset, top) shows the boat just before the 'big one' — estimated at more than 20 feet — hits. In the spread, the boat is vertical.

continued in middle column of next sightings page



## crew list — cont'd

The basic instructions for using the Crew Lists can be found online, so this is mainly a reminder and a bit of a pep rally. But as a quick review, the mission of the Crew List has always been the same: to get people who *want* to crew together with skippers who *need* crew. When you fill out the appropriate form for the kind of sailing you hope to do

in 2008, your information will go online immediately (another big difference from the stone age of two years ago) — there to be viewed and possibly acted upon by potential crew or skippers.

Our 'sea trials' for this brave new world were done on last fall's Mexico-Only Crew List, and we were, at first, disheartened by the seeming lack of skippers looking for crew. We finally realized that lots of boat owners were taking part — but they were finding crew so fast (and thereafter removing their listings) that the list always seemed small. So one of the similarities between the 'new' lists and 'old' remains intact — don't delay, because the best rides can come and go quickly, especially those involving racing, since racers need to put their programs together a bit earlier than the other groups.

The Racing, Cruising and Daysailing categories are self-explanatory. 'Co-Chartering' just means you're willing to pitch in with other folks to share expenses aboard a charter boat in some far-flung locale, or perhaps join in with a larger group for a flotilla charter. The Boat-Swapping category, which seems like a great idea to us but has always been the least-used category, simply means you are volunteering to 'swap' your boat for a week or more with someone in, say, Chesapeake Bay — that family sails your Islander 36 around the Bay for a week while you enjoy their like-size boat on the Chesapeake.

The bottom line: For just about any sailing experience you'd like to try, short of sailing in the America's Cup, there is a Crew List category. (We hear there are still openings on a few America's Cup teams if you're a lawyer — though you won't be doing much sailing.)

As mentioned, the Crew Lists are open to anyone, and you don't have to be listed to contact those who are. However, we do ask that you take responsibility for whatever comes of it. So, for the record, the *Latitude 38* Crew List, and the Crew List forms, are intended for informational purposes only. *Latitude 38* does not make or imply any guarantee, warranty or recommendation as to the character of individuals participating in the Crew List or the conditions of the boats or equipment. You must judge those things for yourself.

Finally, if you're a newbie at all this, or haven't 'Listed in awhile, here are a handful of tips to get you back in the groove.

1) Be honest. The simplest rule of all. In this case, being honest means not inflating your experience or skill level because you think it's what someone wants to hear. In sailing, perhaps more than any other sport, if you don't know what you're talking about, people who do can recognize it instantly. BS'ers don't get rides.

Contrary to what you might think, honest folks with little or no experience often get rides. It has to do with some experienced skippers preferring to train people in their way of doing things.

2) Women can use first names only if they want. Why? Because if you are female, you *will* get contacts. Possibly lots of them. Back in the paleolithic epoch when all Crew Listing was done over the phone, we knew women who claimed they got hundreds of calls, sometimes months after the Crew List was published. For the same reason, we

continued on outside column of next sightings page



# SIGHTINGS

## crew list — cont'd

also recommend that women use only emails for their contact information — and *not* phone numbers.

3) Follow through. Realize that taking part in the Crew List involves certain obligations — and that by signing up or taking part, you intend to live up to those. Along the same lines, also please realize that the Crew List has enjoyed a long life and great reputation, so don't be a bad apple.

4) Unlike the old days, the online Crew Lists are free. And everyone who takes part is invited to our spring Crew List Party April 3 at Golden Gate YC, where we will get \$7/person out of you at the door to cover expenses. We'll have more on the Crew Party in a few months.

For the Crew Listers in particular, the party can be about more important things than being entertained for a few hours. Everyone wears color-coded name tags indicating whether they are boat owners looking for crew or crew looking for boats, so the party of the first part is easy for the party of the second part to spot at the party. And if the parties of Cruise and Cruz are there, then you could party with the Cruise party of Cruise and Cruz and . . . oh, never mind.

— jr

## geja for sale again

Does everybody remember Eli and Sara Bottrell? A year ago October the Northern California couple responded to a story in *Lectronic* for the Islander 36 *Geja*, which had been cruised most of the way around the world by Dick and Shirley Sandys of Palo Alto. After Dick died, Shirley put the boat up for sale, where is, as is. She just happened to be in Spain, and the price was just \$10,000 to move the boat quickly.

Sorely tempted to buy the boat ourselves, we announced that it would be a great deal for a young couple wanting to have a low-

cost cruising fling before continuing on with their lives. Because they were quick, the Bottrells, a young couple indeed looking for an inexpensive cruising fling, quickly made an offer and got the boat.

How did it turn out? "My wife and I recently returned home after seven months of sailing the Med," writes Eli. "The trip was incredible, and we're extremely pleased that we made the decision to drop everything and go cruising."

We'll have a long report from the Bottrells in the February issue of *Latitude* but, other than a temporary problem with the autopilot, the boat was trouble-free. They did, however, do quite a bit of work on her before setting out.

With the couple about to charge into 'real life' mode, they're putting the boat up for sale, where is, as is, for \$20,000. She just happens

continued on outside column of next sightings page

## pucker factor

third photo (inset, bottom), the boat is on its side but, as designed, it righted itself within 10 seconds and the crew motored in before the next set. It probably goes without saying that these boats are built expressly to handle these conditions, and the crew is strapped securely in place.

So next time you deride the Coast Guard for inconveniencing you with a safety boarding, part of their new Home-



**Yes, that's Tom Perkins' Belvedere-based 289-ft 'Maltese Falcon' that Sara and Eli are posing on. They met the captain, and he gave them a tour.**

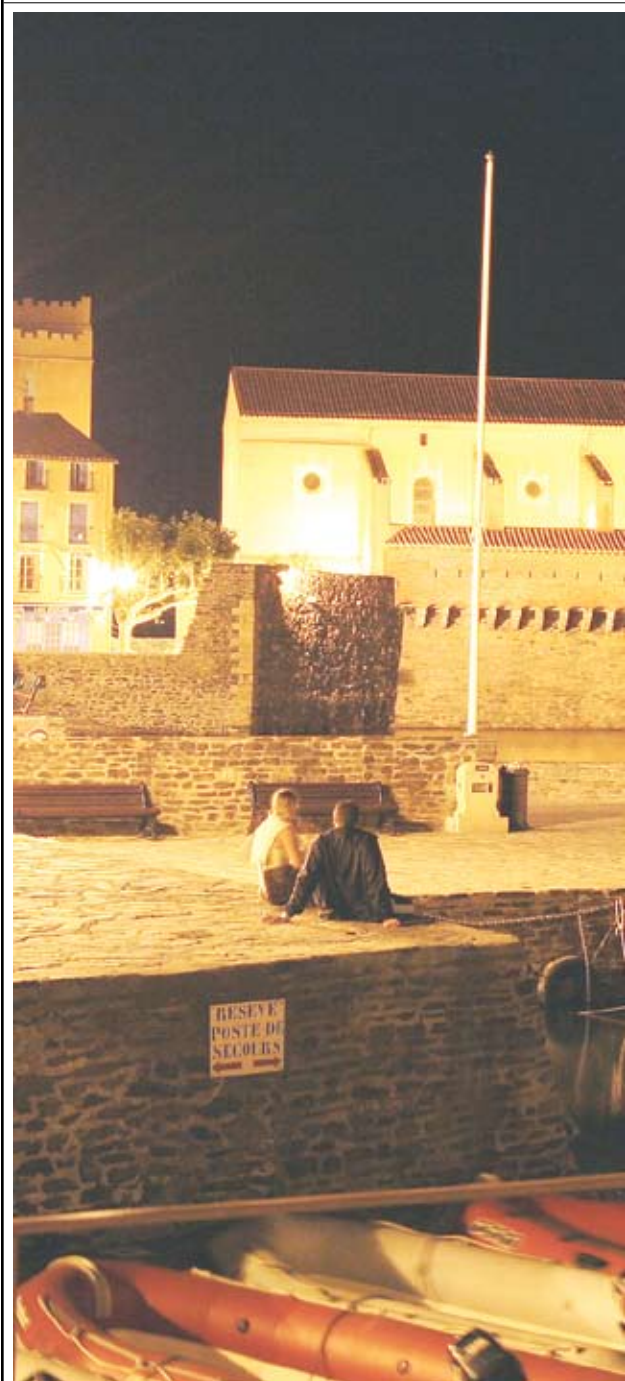

**— cont'd**

land security duties, remember these photos, and remember the most important of their many missions — going to the aid of those in peril on the sea. So when the crap hits the fan and most of us weekend warriors go running for cover, the Coasties go out into the belly of the beast and save lives.

This is how they practice for it.

— jr

**geja — cont'd**

to be up a river near Pisa. True, it's twice the price they paid for the boat, but they did a number of improvements, and the price may or may not include an inflatable and outboard.

If you see any spots on the pages, it's because we're drooling again. Let's see, if we got three other partners, that would be only \$5,000 each — for a boat just a short distance from Capri and Elba, and not all that far from Greece, Turkey, Croatia, Spain and France! To be fair, we'll give everyone a few weeks to do a deal on the boat — email the couple at [geja@bottrell.org](mailto:geja@bottrell.org) if you're interested. If she's not sold by then, we don't believe we'll be able to stop ourselves.

— richard

*Not having a lot of money didn't stop Northern Californians Eli and Sara from enjoying a summer of cruising their own 36-footer in the Med. It's going to be hard for them to resume normal life after enjoying many romantic ports — some of them with free berthing — along the Italian coast.*





# SIGHTINGS

## yra calendar is out

It may come as news to some of you that *Latitude* publishes, not 12, but 13 magazine-size publications every year. In addition to the regular monthly 'books', 2007 marks the 17th year for our *Northern California Sailing Calendar and YRA Master Schedule*, which is now available at all the usual outlets that carry *Latitude*.

The *Calendar* started out as kind of an experiment back in 1991. Although we've always tried to keep up with things in our monthly *Calendar* column in the magazine, there was no one central source that listed all the various YRA races, clubs, contacts and other information that racers need. So we thought we'd create one and see if it got any traction. That it did, like a muscle car doing burnouts, and it has grown by leaps and bounds every year since. The first year, it was

continued on outside column of next sightings page

## hubris happens

Call it Murphy's Law, or just bad luck, but sometimes trouble strikes in the final phase of an otherwise uneventful journey. It happened to Nigel Tetley near the end of the famous Golden Globe Race — a shoe-in for the fastest time, his boat broke up 2,000 miles from finishing the first solo 'round-the-world' race. It happened to voyager William Peterson — he was forced to abandon his Newport 40 after dismasting several hundred miles short of completing a nine-year circumnaviga-

continued in middle column of next sightings page



## yra calendar — cont'd

only 12 pages long. This year — it's hard for even us to believe this — it weighs in at 100 pages! And by all indications, it is a valuable resource for everyone who races in Northern California, from YRA to PICYA to yacht clubs to individual racers.

There's lots of great stuff in the 2008 edition, including:

- A YRA sign-up form (there's also one of these in this issue). Which means you've run out of excuses for getting these in late.
- Women's program — the official list of 18 races which constitute our Women's Challenge. The woman who participates in the most gets recognized in these pages as 'Queen of the Women's Circuit'. The 2007 winner was Lucie Mewes.
- Basic Racing Guidelines — Paul Cayard can skip this part, but we've reduced the often complex and confusing racing rules to 10 easy-to-understand ones, which begin with the unwritten "Have Fun!"
- YRA's latest rules, courses, changes and fleets for 2008 — even charts indicating where all the buoys are.
- A listing of nearly every youth program in Northern California — four column's worth — and how to get in contact with all of them.
- Sunrise/sunset times and tide currents for every weekend.
- Contacts for, well, just about everybody and every organization having anything to do with racing on the Bay, rivers or lakes.

And last but not least, a bunch of great advertisers who make it all possible. Please give these great folks all the support you can in the coming year — and tell them you saw it in the *Latitude* Calendar!

Now go grab one before they're all gone.

— jr

## three west coast-bound boats missing

The searches for three missing West Coast-bound boats have been suspended indefinitely, though the Coast Guard is asking everyone to keep a sharp eye out for them.

Everett Evans, 67, set off from Kauai, Hawaii on August 17, bound for Ketchikan, Alaska on his Aquarius 21 *Grace*. The boat is a small trailerable daysailer that, according to official estimates, should have made it to the West Coast by the end of September.

Chris Malchow, 31, and Courtenay Steele, 27, left Hilo on September 8 aboard *Takaroa II*, their 30-ft Tahiti ketch. *Takaroa* was equipped with EPIRB, GPS, a liferaft and other safety gear, but their radio wasn't working. A major search was launched with no sightings.

Finally, Haoshi Yara, also 67, and on his way from Japan to either Vancouver, B.C. or San Francisco, was last heard from on October 18 when he was about 800 miles off the Oregon coast. His rudder had been disabled, he'd run out of diesel, his main had been damaged and he was steering with an emergency tiller.

If you have information about any of these boats or their owners, contact USCG Alameda at [rcalameda@uscg.mil](mailto:rcalameda@uscg.mil) or (510) 437-3701.

— ladonna

## sea of cortez sailing week returns

Back in '83, the Wanderer and Kathy McCarthy, who founded *Latitude 38*, spent Thanksgiving Day anchored on our Freya 39 *Contrary to Ordinary* at Caleta Partida, about 25 miles north of La Paz. It was so beautiful and the water was so warm that the Wanderer decided it would be cool to hold an Antigua Sailing Week-type end-of-season event there for cruisers. So in the next month's *Latitude*, we announced that we'd return the following March with a BBQ, volleyball net, and some ideas for a race course, for what we dubbed Sea of Cortez Sailing Week.

It was an idea whose time had come, because just about everybody with a boat or an interest in boats in La Paz seized the idea and ran like

continued on outside column of next sightings page



DOUG THORNE

**Just when they were probably thinking about getting out the docklines and fenders . . . whammo!**

## pacific cup preview

The Pacific Cup — with starts between July 14-19 — returns this summer with more emphasis on the 'fun race to Hawaii' aspect than ever before. Begun in 1980 as an 'even year' alternative to the more serious TransPac (which runs in odd-numbered years) — and with the added attraction of a San Francisco start — the Pacific Cup has become a must-do West Coast event in its own right. Limited to 70 boats by the capacity of Kaneohe Bay, the Pac Cup rarely fails to deliver capacity crowds at the end of its sun-drenched 2,070 course. And though few boats are turned away, the waiting list is always long. This year is no exception, with — count 'em — 79 sign-ups already showing on the race website. That group includes a number of 'usual suspects' as well as some fresh new faces. Among the veterans:

*Merlin* — Bill Lee's original Magic Bus returns to the scene of three previous elapsed time records. Donn Campion is chartering the 67-ft thoroughbred.

*Rage* — Another big ultralight and Pac Cup record holder. Steve Rander will once again be at the tiller when the Wylie 70 hits the starting line.

*E.T.* — Liz Baylis and Todd Hedin's Antrim 27 has won her division three times in a row and is back for another try.

That's just a quick glimpse. We'll be featuring much more about the Pac Cup in the months to come. In the meantime, log onto the website ([www.pacificcup.org](http://www.pacificcup.org)) and check out the latest news, crew list, seminar schedule — and yes, even online entry forms!

— jr



# SIGHTINGS

## sailing week — cont'd

hell with it. So when we showed up at Caleta Partida, 64 boats were already there, and there had already been a big formal-dress opening ceremony in La Paz with local officials and the Mexican Navy. There were also a Mexican Navy destroyer at Caleta Partida to start two of the races, a Mexican Air Force plane that did a fly-by, and all kinds of prizes donated by merchants in La Paz and the tourism folks.

Boat races were held on three afternoons and, on the other days and nights, there were social events on the beach. Chess, backgammon and other games were popular, and so was playing music. Since a vendor had come up from La Paz and set up a big beer concession, and because we were so young and naughty, we engaged in some youthful indiscretions, too. For example, we organized a wet T-shirt contest for the women and a wet bun competition for the men. In retrospect, it's amazing how many women and men were happy to strut their stuff in these contests, which turned out to be strange combinations of group love — in the platonic sense — and lightweight lust.

Anyway, Sea of Cortez Sailing Week took off like an ultralight sled down a steep wave in the Cerralvo Channel. The following year over 200 boats showed up, and there was a more elaborate beach concession, with hundreds of chairs, scores of tables with umbrellas, and several outhouses. Before long, we were roasting pigs in the ground, and some particularly well-endowed women were setting up their cruising itineraries around the dates of the wet T-shirt contest.

But as should have been expected, as the event grew, certain people began to smell money. They couldn't be held in check by committee members, as most of them sailed off to other parts of the world after the event. As the 'father' of Sea of Cortez Sailing Week, we were too far away and had too many other things to do to supervise. So after about five strong years or so, Club Cruceros de La Paz sort of adopted the event and, while some years were better than others, it went into a long period of considerable decline. After limping along for about 15 years, a La Paz restaurant set up a competing event out at the islands on the same dates, and Club Cruceros decided to throw in the towel. The restaurant's event lasted but two weak years. For the last three years, Club Cruceros has hosted La Paz Bay Fest instead, which is a lot of social activities and one race. And they will be doing that again this year on April 11-13.

But we're here to announce that Sea of Cortez Sailing Week is back! Based on the great attendance — 100 or so people on 29 boats — and the great fun that everybody had at December's Pirates for Pupil's

Banderas Bay Blast, it's become clear to us that there's a certain segment of the cruising population in Mexico whose desire for 'nothing serious' racing is not being met. So we're reviving Sailing Week out at the islands north of La Paz — but on a more modest scale.

Why not have a huge one like the old days? Primarily for ecological reasons. Turtle

**The lovely women in the first ever Sailing Week seemed to enjoy it as much as the grizzly men.**

Bay, Bahia Santa Maria and Cabo can all handle Ha-Ha size fleets, but that's not true for Caleta Partida. As such, there will be no beach concessions, no outhouses, no cooking pigs on the beach, no outboard-powered dinghy racing and, as long as some individuals — we

continued on outside column of next sightings page

## hubris

tion. And it happened to a delivery crew bringing the Celestial 48 *Tamara Lee Ann* back to Alameda from the Baja Ha-Ha.

After an otherwise trouble-free 1,250-mile bash up the coast, the crew apparently lost their concentration momentarily while entering the Oakland Estuary and slammed into a set of pilings near the Alameda Ferry doing six knots. The boat's



## — cont'd

permanent slip lay only a mile away.

We air this sad tale not to beat up on the delivery crew — hey, you-know-what happens, especially in the realm of sailing — but as a warning to everyone to always keep a proper watch and anticipate potential mishaps, even when you think you're home free.

— andy

## sailing week — cont'd

won't mention any names — can contain their deep-seated ecdysiastical urges, there won't be any official wet T-shirt or wet buns contests either. In fact, with a core group of three big cats — Wayne Hendryx and Carol Baggerly's Brisbane-based Hughes 45 *Capricorn Cat*, Jim Forquer's Newport Beach-based Catana 52 *Legato*, and *Latitude's* Punta Mita-based 63-ft *Profligate* — some, if not all, of the social events will be on the boats as opposed to the beaches. And maybe we'll rotate the base of activities from Caleta Partida to Ensenada Grande or, if the

continued on outside column of next sightings page

**Spread:** Nobody ever expected that more than 200 boats would show up in Caleta Partida for Sea of Cortez Sailing Week. **Inset:** Boats of all types, from 20-footers to the 73-ft 'Kialoa II' would race in the early years.

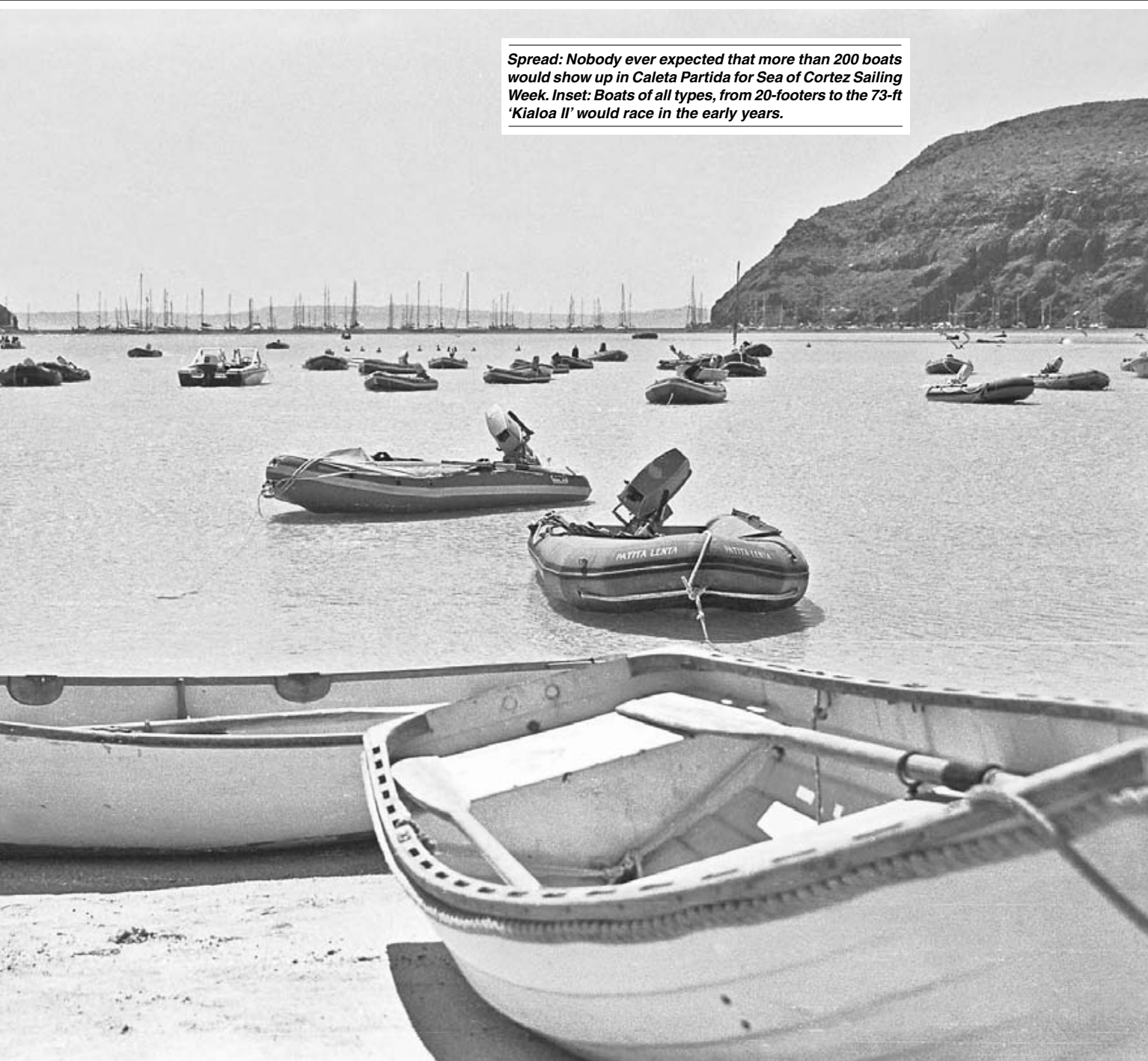



# SIGHTINGS

## sailing week — cont'd

wind is right, have a fun race up to Isla San Francisco. The dates will be April 1-6, and that's no April Fool's joke.

Given the initial favorable response we've received to the concept, the problem might be how to limit participation to 30 boats and 100 people. We're going to attempt to do this by emphasizing the fact that this event will be much more sailing-oriented than socially-oriented. In other words — and we sure don't want to sound elitist — if

continued on outside column of next sightings page

## short

**EUREKA, CA** — We don't think Craig Peterson had a death wish, but he certainly showed poor judgement when he left Brookings, Oregon in late November bound for Alaska aboard his, ahem, Catalina 25 *Jack* . . . and just a few days before one of the biggest — and best forecasted — storms of the season.



MARTIN COUDRIET

## sightings

Peterson called a *mayday* on December 2, notifying the Coast Guard that his rudder had broken and he was taking water over the side of the boat. A helo out of Humbolt Bay located *Jack* 30 miles offshore in 30-ft seas and 45-knot sustained winds. Peterson jumped overboard and

continued in middle column of next sightings page



**Benoit Lequin and Pierre-Yves Moreau** raced this 20-ft beach cat 2,700 miles across the Atlantic faster than all 240 boats in the Atlantic Rally for Cruisers.

## sailing week — cont'd

you and your boat are like a voyeur at an orgy when it comes to fun racing, and you don't like to fly chutes, this event won't really be up your alley. But it doesn't matter what kind or size of boat you have, if you're into Ha-Ha-style racing, and believe in being super-respectful of the environment, email [richard@latitude38.com](mailto:richard@latitude38.com) and let us know how interested you are.

We want Club Cruceros to know that we have no intention of competing with their La Paz Bay Fest, where the importance of sailing to social activities is reversed. In fact, we believe a revived Sea of Cortez Sailing Week can attract boats to La Paz that will be happy to participate in La Paz Bay Fest, too.

— richard

## more french record breakers

There's no denying that the French are showing the world the way when it comes to ballsy ocean sailing. The day before Francis Joyon set the new 24-hour record with *IDEC*, Benoit Lequin, 33, and Pierre-Yves Moreau, 35, two other Frenchmen, established a new transatlantic record for a . . . beach cat.

The very experienced duo sailed their 20-ft cat 2,700 miles from Dakar, Senegal, to Pointe-a-Pitre, Guadeloupe, in just 11 days and 11 hours, breaking the old record by more than two days.

For the sake of comparison, the first three boats to finish the 2,700 miles Atlantic Rally for Cruisers, from the Canary Islands to St. Lucia, were the *Matelot*, a Southern Wind 80, which took 12 days, 15 hours; *AAG Big One*, a Volvo 70 that took 12 days, 13 hours; and *Venemous*, a Swan 86 that took 12 days, 13 hours.

*Incredible, no?*

— richard

## updates in the bismarck dinius case

Channel 7's Dan Noyes has been doing a terrific job of following up on what we think is an outrageous case of injustice in Lake County. He's put the spotlight on three telling pieces of new information:

- Sheriff Deputy Russell Perdock has changed his story three times in regard to his speed the night he slammed his powerboat into the drifting sailboat on which Lynn Thornton was killed. 40? 45? 35? He can't seem to make up his mind, but even if it was 'only' 35, it was too fast for the conditions, clearly in violation of California boating laws.

- All six Lake County judges recused themselves from Perdock's divorce proceedings because they all knew him personally but, oddly, two have refused to do so in the Bismarck Dinius case.

- Noyes interviewed Perdock's soon-to-be ex-wife who claimed Perdock was a speed freak — he loved driving his cars and boats fast, scaring his wife and endangering others in the process.

To get the details on these revelations, check out Noyes' excellent coverage at <http://iteamblog.abc7news.com>.

— ladonna

## ice station tara

The 119-ft aluminum schooner *Tara* has been adrift for more than a year, and the eight-person crew is anxious to start sailing again. But it's going to be at least another month of scientific work, snowball

continued on outside column of next sightings page



"Oui oui! We are zee best!"

JF MADELAINE / ARCHI-FACTORY



# SIGHTINGS

## *tara* — cont'd

fighters and hikes to the outhouse before that happens. Then again, how many people can say they've drifted more than 3,000 miles — frozen solid in ice?

That's right, the research vessel *Tara* and her crew have been traversing the far 'northwest passage' with the Arctic sea ice itself. In addition to having one of the most unique experiences of any modern voyager, they have made some amazing and startling discoveries.

The beginnings of this expedition go back years. In fact, you could say the beginnings of the *Tara* Expedition began with the brutal murder of Kiwi sailing legend Sir Peter Blake by pirates in the Brazilian Amazon in December, 2001. At that time, the boat was named *Seamaster*, and Blake captained not only the specially built boat, but Blakexpeditions, an ambitious project to sail and study the health of the world's oceans — which included an Antarctic voyage just prior

continued on outside column of next sightings page

## shorts

was saved by a rescue swimmer.

**LAGOS, PORTUGAL** — French siblings Corinne Caspar, 49, and Thierry Beille, 52, were each sentenced on December 12 to 24 years in prison for the murder of André Le Floch. Prosecutors successfully proved that the pair beat and strangled the 67-year-old Le Floch on August 17, 2006, in an effort to steal his 66-ft trimaran, *Intermezzo*, worth \$143,000.

Caspar and Beille were found adrift in a dinghy off the coast of Portugal that day, not far from the capsized *Intermezzo*, where rescuers found the bound and weighted-down body of Le Floch. Au-



## — cont'd

thorities believe the inexperienced pair caused the capsizing by not lowering the centerboard during a mild storm.

**GEORGETOWN, SC** — The Coast Guard covered 50,000 square miles between Delaware and Miami over four days in early December searching in vain for two overdue Canadian sailors aboard their *Columbia 29 Pride*. The search was suspended on December 12.

On December 13, a disabled *Pride* was towed into Georgetown after surviving a storm that blew her off course. Her crew was unharmed, if a little exhausted.

— *ladonna*

*tara* — cont'd

to the Amazon.

The fate of the boat and the project were lost in the flurry of press and outrage over Sir Peter's death. *Seamaster* resurfaced in Newport, Rhode Island, in 2003 where Pippa Blake, Sir Peter's widow, put her up for sale. Included was all the scientific equipment which Blakexpeditions had installed, as well as lots of cold weather gear.

Grant Redvers acquired the boat in 2004 and renamed her *Tara* for the French non-profit Tara Expeditions, an organization which sponsors studies of the impact of global warming in the high latitudes.

Although the end of Blakexpeditions was nearly as traumatic for his family and followers as the loss of the man himself, we feel Sir Peter would be proud of what she has accomplished. Most recently, Redvers and a scientific team sailed her up into the Arctic seas above Alaska and, in September, 2006, let the ice grab her. They've been riding the 'conveyor belt' ever since. At the one-year mark, they had traveled 2,100 miles — the length of a TransPac — from west to east, in the process passing closer than any other boat in history to the North Pole: 88 miles. In December, the ice started showing signs of weakening,

but they don't expect to be fully released and underway until sometime in February in the area near Fram's Strait (between Greenland and Spitzberg) at 80° N. Total transit time will have been around 400 days; total distance, around 3,000 miles.

*Tara* is of course not the first vessel to be frozen in ice. The ice grabbed and crushed many a ship in the old days (the loss of 31 whaling ships in this same area in 1871 broke the back of the American whaling industry). But she is one of only a few expressly designed to deal with the brute force of nature in such a situation. Besides being built extremely strong, her steeply flaring sides tend to make her 'squirt' above the crushing force of the ice, like a slippery watermelon seed squeezed between the fingers.

She is superbly outfitted for her mission. Updates made by the *Tara* team include solar panels, wind generators and LED lighting, which make her 60% more energy efficient than before. She makes fresh water by melting ice. The crew grows their own vegetables to supplement the nine tons of stores

aboard. And they use 'outhouses' set away from the boat so that the environment surrounding the boat does not become contaminated. This 'black water' will remain frozen in the ice until it's released in the Greenland Sea, and "broken down by natural processes." They compact and keep the rest of their wastes for later disposal.

The main purpose of *Tara's* ice drift was to study the Arctic sea ice. Studies of the last few years indicated that it's going away faster than it's forming. Some models predict it will only be a few decades before it disappears completely every summer. This, of course, would have an enormous environmental and socio-economic impact.

So far, almost every test and observation done by the *Tara* team indicates that the models are incorrect — the ice is actually moving and melting *faster* than previously thought. The boat moved about six miles a day, twice what the *Tara* team had predicted and three times more than the models said. The ice was also much thinner, and outside temps don't get as cold as they used to. The mean temperature last month, for example, was 'only' 18° below zero — practically tanning weather compared to a decade ago. The most shocking prediction to come of the study: "Given the actual pace of ice pack retreat . . . 8 to 10 years would be sufficient for the summer ice pack to disappear," said a recent report.

*Tara's* complete body of findings and their consequences are far beyond the scope of our brief mention here. But to anyone concerned about global warming and the environment — or just about one of the great boating adventures in modern experience — their website is a must-read: [www.taraexpeditions.org](http://www.taraexpeditions.org).

— jr



Freeze frame — Shackleton's 'Endurance'? No, the spread shows 'Tara' during her frigid Arctic passage. Above, just who was brave enough to use that bike?



PHOTOS COURTESY TARA



---

# CABO CATASTROPHE REVISITED



---

## — SHATTERED DREAMS

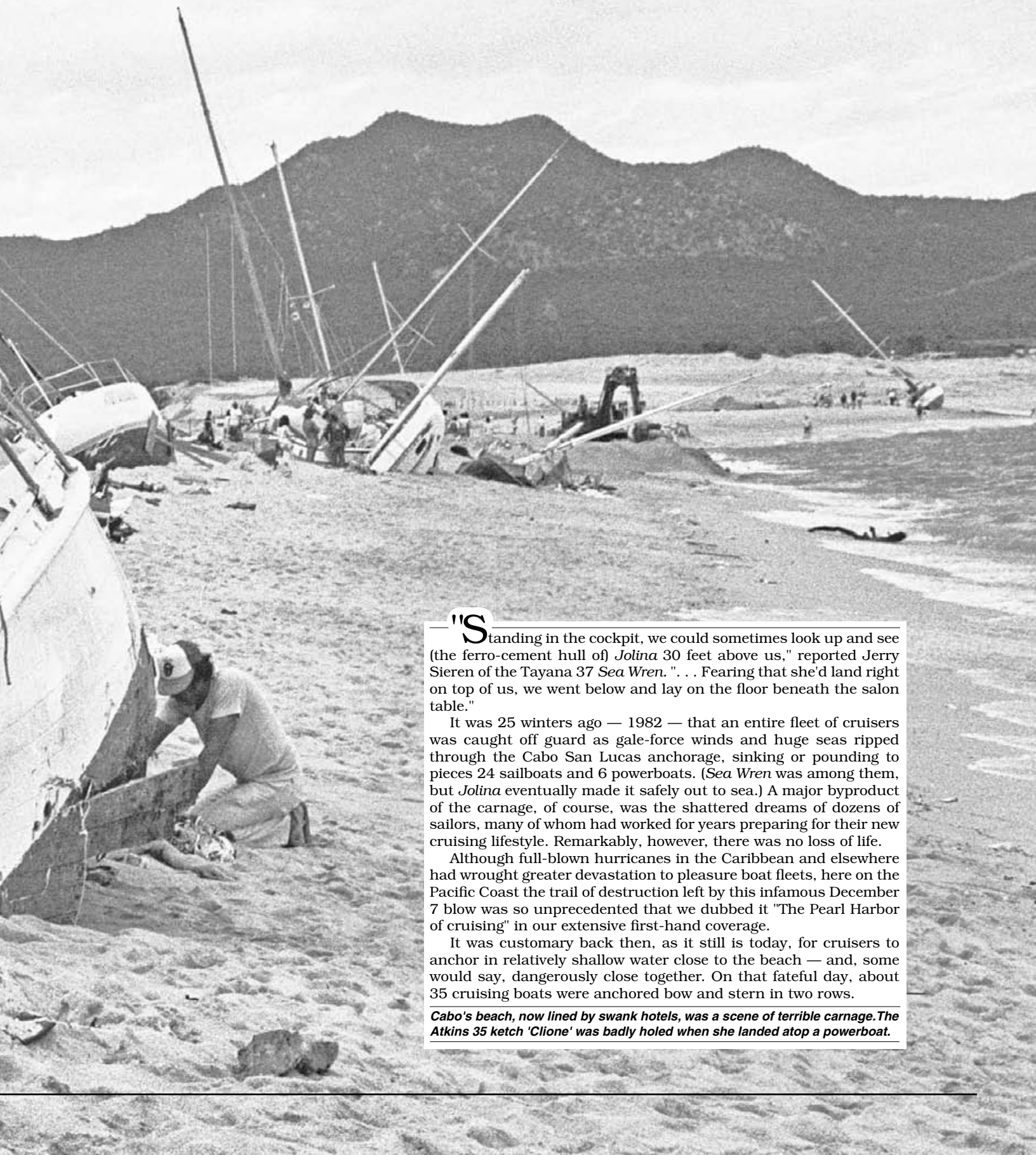

— "S"tanding in the cockpit, we could sometimes look up and see (the ferro-cement hull of) *Jolina* 30 feet above us," reported Jerry Sieren of the *Tayana 37 Sea Wren*. ". . . Fearing that she'd land right on top of us, we went below and lay on the floor beneath the salon table."

It was 25 winters ago — 1982 — that an entire fleet of cruisers was caught off guard as gale-force winds and huge seas ripped through the Cabo San Lucas anchorage, sinking or pounding to pieces 24 sailboats and 6 powerboats. (*Sea Wren* was among them, but *Jolina* eventually made it safely out to sea.) A major byproduct of the carnage, of course, was the shattered dreams of dozens of sailors, many of whom had worked for years preparing for their new cruising lifestyle. Remarkably, however, there was no loss of life.

Although full-blown hurricanes in the Caribbean and elsewhere had wrought greater devastation to pleasure boat fleets, here on the Pacific Coast the trail of destruction left by this infamous December 7 blow was so unprecedented that we dubbed it "The Pearl Harbor of cruising" in our extensive first-hand coverage.

It was customary back then, as it still is today, for cruisers to anchor in relatively shallow water close to the beach — and, some would say, dangerously close together. On that fateful day, about 35 cruising boats were anchored bow and stern in two rows.

***Cabo's beach, now lined by swank hotels, was a scene of terrible carnage. The Atkins 35 ketch 'Clione' was badly holed when she landed atop a powerboat.***

---



# CABO CATASTROPHE REVISITED

Today, of course, sailors have all manner of weather forecasting data at their fingertips. But in the early '80s, a falling barometer and ominous skies were the principle predictors of trouble ahead when cruising Mexican waters.

On December 7 the weather had been unsettled all day, then late in the afternoon a brief 25-knot squall blew through from WSW. But only a few sailors took the cue and headed out to sea, as the anchorage was protected from that direc-

tion. And besides, it was a full five weeks after the official end of hurricane season. "I didn't do anything because nobody else did," was a common admission in the aftermath.

The *Sea Wren* crew described how, shortly before dark, the wind accelerated from zero to 35 knots in a quarter of an hour out of the SSE — an angle from which the local topography offered no protection. Other reliable sources report-

ed sustained winds of 45 knots during the six-hour ordeal, with gusts up to 60. But as always, it was the accompanying waves which did most of the damage. Various reported to be 8, 10, 15 feet and larger, they were, by any measure, sufficiently stout and powerful to turn the normally tranquil anchorage into a battlefield. Within minutes the most experienced sailor of the lot was in the process of learning a very hard lesson.

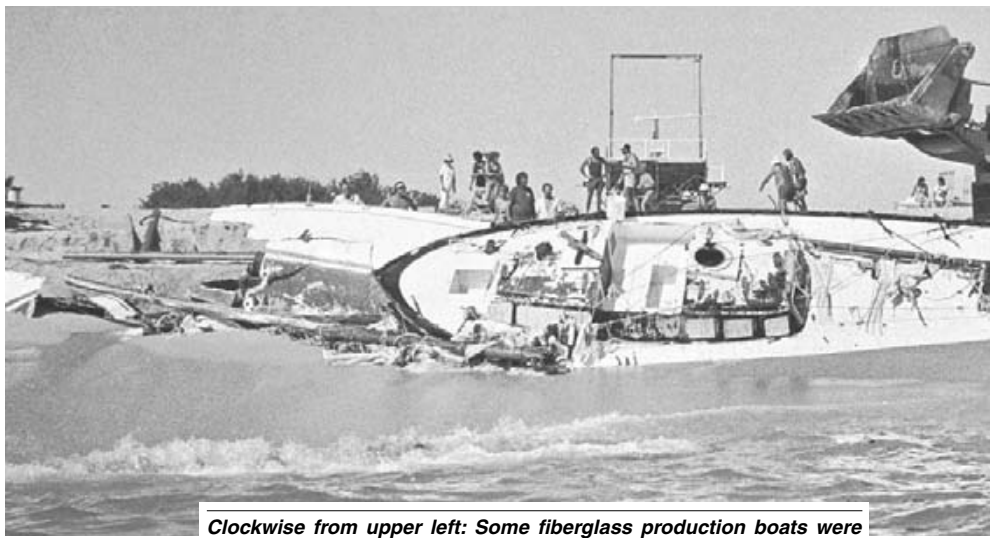

*Clockwise from upper left: Some fiberglass production boats were completely obliterated; Moitessier's dismantled 'Joshua' was eventually resurrected by a new owner; although the CT 37 'Gypsy Magic' looks salvageable, she too was a total loss; the normally pristine beach resembled a battlefield; many hands contributed to the refloating of the Bristol Channel Cutter 'Vagabundo'. All photos latitude / richard*



## — SHATTERED DREAMS

Acclaimed French singlehander Bernard Moitessier — who had been living in Sausalito for several years previously — had anchored his steel-hulled, 40-ft ketch *Joshua* closest to the beach of all. He was soon on the radio requesting assistance, as his one-lunger diesel was no match for the waves' tremendous force. But his neighbors all had their hands full, to put it mildly, and *Joshua* was the first to be swept up the beach. Many others fol-

lowed shortly afterwards, including the L.A.-based Peterson 44 *Freling*, which was swept right over *Joshua*, dismasting her. The next day Moitessier, then 57, reasoned that he could not face the prospect of a rebuild and simply gave away the battered hull to a crewman off the San Francisco-based schooner *Elias Mann*. (That wooden 68-footer had weathered the storm safely.)

In the aftermath of the tragedy ev-

everyone had a dramatic tale to tell, some of them textbook illustrations of how a series of problems can escalate into calamity. Aboard the Nevada-based Bounty II *Adalante*, for example, a sheet fouled the prop while her crew was attempting to set sail toward open water. The Novato-based *Wind Dancer's* anchor chain jumped the windlass then snapped her sampson post. Both boats were total losses. Others reported heavy anchor chain breaking due to the strain of the

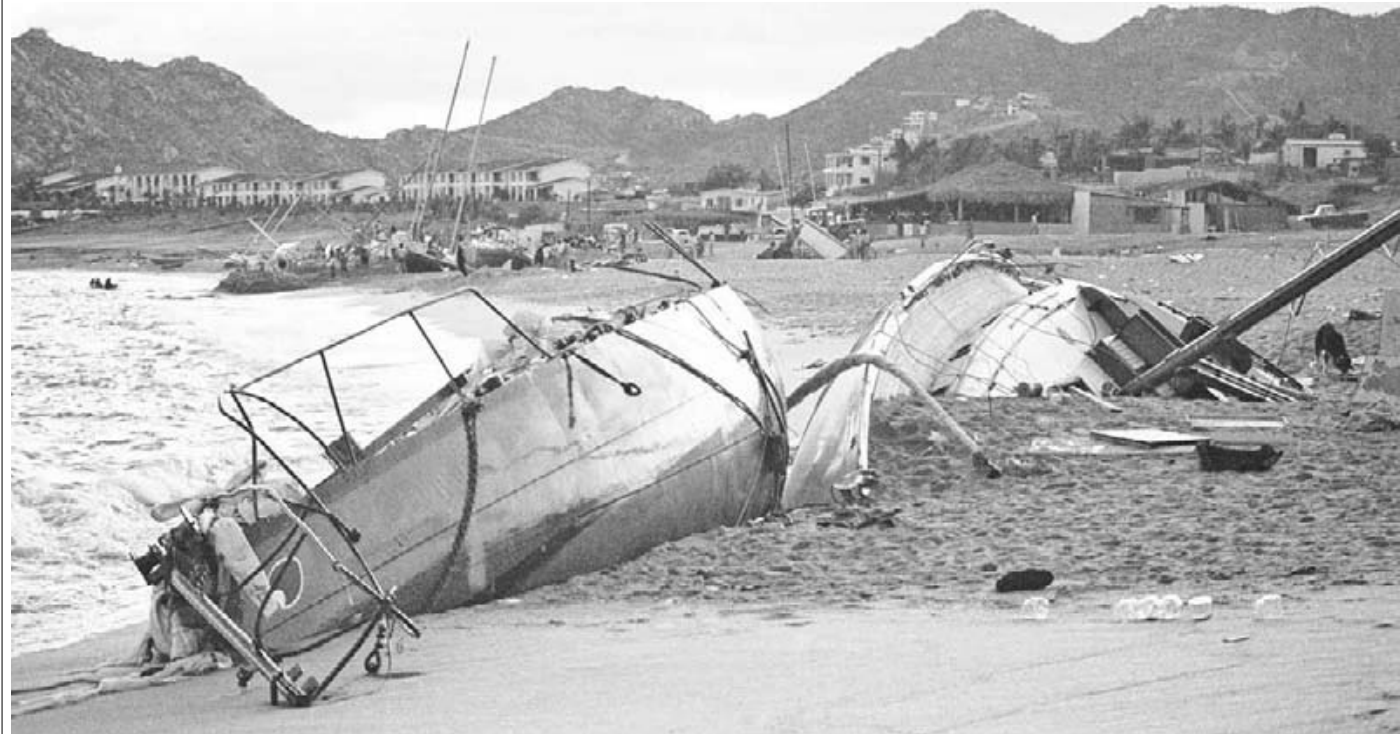



# CABO CATASTROPHE REVISITED

violent waves. And perhaps most vexing was the fact that the near-shore waters became littered with all manner of debris, which made fouling of props and engine intakes almost a certainty.

One of the lessons learned from this painful night was that some

of the boats anchored in deeper water came through it completely unscathed, apart from their crews' jangled nerves. Most, but not all, who went out to sea early dodged the bullet also, but few who attempted to do so during the height of the chaos were successful. Some of the surviving boats and their crews went on to cruise extensively, however. A few even circumnavigated, such as Paul and Susan Mitchell, who rode out the big blow at anchor aboard their 58-ft Alden schooner *White Cloud*. Twenty-five years later, they're still out cruising.

There were also happy endings for



LATITUDE / RICHARD

***The Seattle-based Omega 46 'Grace' was one of the lucky ones. Supported by a sand berm, she landed upright, virtually unharmed.***

at least four of the beached boats. The inherent toughness of the Vancouver-based Bristol Channel Cutter *Vagabundo* allowed her to sail again another day. By contrast, the light weight of the Santa Cruz-based *Notorious*, a three-month-old Olson 40, probably led to her surviving relatively unscathed, as she was tossed high up the beach. Perhaps the luckiest boat of all, though, was the Seattle-based Omega 46 *Grace*, which was washed ashore in a position which left her virtu-

ally undamaged. The same boat recently participated in the Baja Ha-Ha rally and may continue on next spring to the South Pacific.

Although our informal survey at the time revealed that the vast majority of boats lost were less than five years old, very few of them were insured. Their owners were split about

50/50 on whether to find new horses to climb back up on — so to speak — or to simply hang up their spurs and abandon their cruising dreams. We'll bet those who picked up the pieces and started over are very glad they did, as the Cabo catastrophe of '82 was an anomaly of the cruising life, the likes of which has never been repeated.

— **latitude/at**

*Readers — If you weathered Cabo's big blow of '82 we'd love to hear your recollections and see your photos. Write us at [editorial@latitude38.com](mailto:editorial@latitude38.com).*

**Blue Sky**  
ENERGY

**Increase Your Solar Output  
With Solar Boost™ MPPT  
Solar Charge Regulators**

**Get All The Power You Need To Weather Any Storm**

The Solar Boost™ 3024i & 2000E are two of the most reliable Solar Charge Controllers on the market & our patented technology extracts all the power your solar panels can deliver, up to 30% more!

Blue Sky Energy Inc. gets rave reviews in *Practical Sailor*. Read the article at [www.blueskyenergyinc.com](http://www.blueskyenergyinc.com)

800-493-7877 or 760-597-1642  
2598 Fortune Way, Suite K, Vista, CA 92081 USA  
E-mail: [sales@blueskyenergyinc.com](mailto:sales@blueskyenergyinc.com)  
Web: [blueskyenergyinc.com](http://blueskyenergyinc.com)

**QUALITY....RELIABILITY....BLUE SKY ENERGY, CHANGING THE WAY SOLAR IS USED EVERYDAY**

# SAN DIEGO'S NEWEST MARINA!!



Six minutes south of downtown San Diego, Pier 32 Marina offers an ideal location for cruiser outfitting, provisioning and boatyard maintenance. Knight & Carver Boatyard and West Marine nearby.

## OPENING EARLY 2008

Beautiful 250 slip marina opening soon. Top notch Bellingham dock system, newly dredged harbor and luxurious shoreside amenities including:

- 28'-60' Single Slips
- Deluxe Showers
- Spacious Laundry Room
- Exercise/Workout Center
- Boater's Lounge
- Swimming Pool/Jacuzzi
- High Speed Internet
- Full Service Deli

**Pier 32 Marina**

**(800) 729-7547**

[office@pier32marina.com](mailto:office@pier32marina.com)

[www.pier32marina.com](http://www.pier32marina.com)

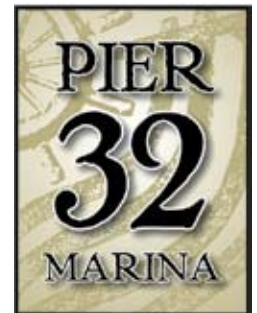

## Blue Water Yacht Insurance

Blue Water Yacht Insurance covers more active cruising boats than any other marine agency in the Western Hemisphere and is the leading innovator of insurance products for the offshore sailor.

### Our Insurance Programs Provide

- Crew of two anywhere
- Hawaii
- South Pacific
- Multihulls
- Racing Boats
- Worldwide Navigation
- Caribbean
- Charter Boats
- Liveaboards

### Quality Rated Insurance Companies

Boats aged 1 to 40 years • "Agreed Value"  
 "All Risks" • "New for Old" replacement partial losses  
 Hulls valued \$50,000 to \$2,500,000

### Worldwide Health Insurance

International and USA health insurance plans at affordable prices.



Call Toll Free **(800) 866-8906**

Fax: (866) 795-3707

email: [sales@bluewaterinsurance.com](mailto:sales@bluewaterinsurance.com)

Quotes requests/Visit our website:  
[www.bluewaterinsurance.com](http://www.bluewaterinsurance.com)



**Portable 12/24 and 110-volt refrigerator/freezer**



- \* Super low amp draw
- \* Will freeze or refrigerate in over 110 degree heat
- \* Made for the marine environment

**FridgeFreeze, Inc.**

5343 Banks Street • San Diego, CA 92110

**(619) 220-6003**

[www.fridgefreeze.com](http://www.fridgefreeze.com)



# SAUSALITO MIDWINTERS

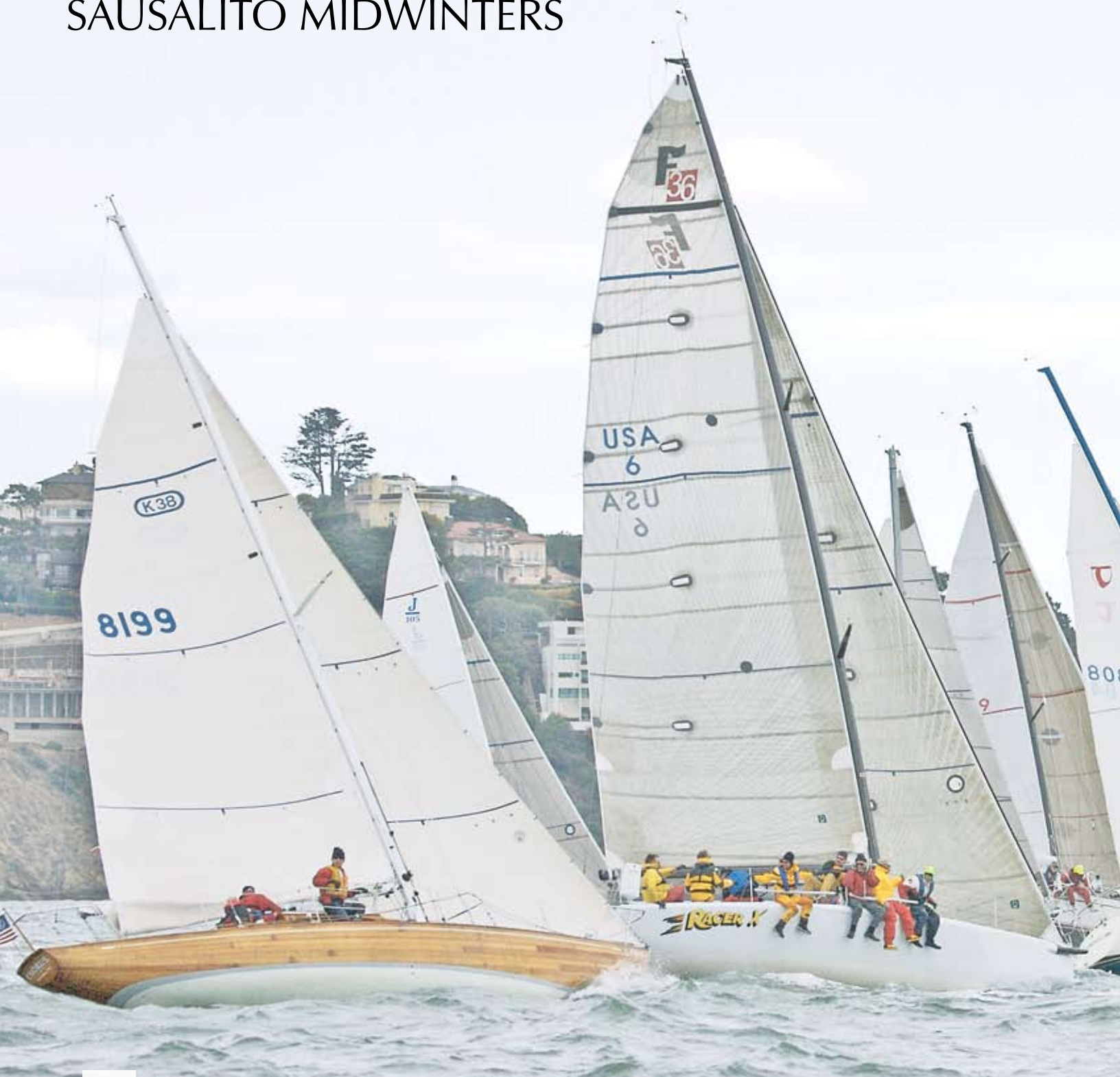

While many midwinter races this season have been . . . well, 'leisurely', Sausalito YC's second race in their winter series — held December 2 — was definitely on the sporty side. Consistent 20-knot southerlies combined with a strong ebb made for a choppy upwind start on the Knox course — when they finally started, that is. "One 'enthusiastic' division caused a general recall,"

***Racers took full advantage of consistent southerlies in Sausalito YC's second midwinter.***

noted SYC's newly inducted Race Chair Paul Adams.

When the race finally started shortly after noon, sailors found smoother waters closer to the Little Harding windward mark. And though the gray skies may have threatened rain, they never delivered, leaving sailors dry, if a bit

chilly. Luckily, the action was spirited enough to keep their blood pumping.

The two laps around the course ended on a downwind leg, treating spectators along the Sausalito waterfront to an eye-catching spinnaker finish, something the racers were also able to enjoy at the barbecue afterward, thanks to the club's unofficial videographer. "Shooting video is a great touch," said Synthia Petroka,

# — TOUCH OF GRAY



crew on Doug Grant's Hanse 342 *Grey Ghost*.

SYC boats currently make up about 70% of the roster, but Adams would like to see more non-club boats join in the fun. In an effort to increase attendance, he pointed out that SYC will give any one-design their own start if they commit five or more boats to any series. "The winter series has been running for 27

years," he pointed out, "and we want to see it run for another 27."

— **latitude 38/ladonna**

DIVISION A HIGH (PHRF over 102) — 1) **Lynx**, Wyliecat 30, Steve Overton/Jim Plumley; 2) **Gammon**, Tartan 10, Jeff Hutter; 3) **Carlene**, Wyliecat 30, Fred Soltero. (6 boats)

DIVISION A LOW (PHRF under 102) — 1) **Racer X**, Farr 36, Gary Redelberger; 2) **Q**, Schumacher 40, Glen Isaacson; 3) **Wicked**, Farr 36,

Richard Courcier. (6 boats)

NON-SPINNAKER — 1) **Roxanne**, Tartan 30, Charles James; 2) **Grey Ghost**, Hanse 342, Doug Grant; 3) **French Kiss**, Beneteau 350, Dave Borton. (6 boats)

J/105 — 1) **Blackhawk**, Scooter Simmons; 2) **Lulu**, Don Wieneke; 3) **José Cuervo**, Sam Hock. (5 boats)

SANTANA 22 — 1) **Tackful**, Cathy Stierhoff; 2) **Betty Boop**, Donald Lessley; 3) **Cloud 9**, Jim Doyle. (3 boats)



# SAUSALITO MIDWINTERS





# — TOUCH OF GRAY



*Seeing red (clockwise from here) — 'Tackful' bounced merrily through the chop; Bruce Nesbit had a full crew on 'Razzberries'; 'Chorus' was pretty as a song; 'Blackhawk' snatched first in the J/105 fleet; the racing was A-OK; riding the wave; Richard Courcier's crew played a 'Wicked' game.*





# WILD RIDE TO WHANGERAU

Take one look at Sereia and you'll know that Peter and Antonia Murphy aren't typical cruisers. The ornate trim on their Mariner 36 is painted in a kaleidoscopic array of bright tropical colors. Young, free-spirited and eager for adventure, they set out from Richmond, CA, in October '05 on a proposed circumnavigation. They'd already experienced plenty of highs and lows when Antonia discovered she was pregnant last May, while en route to the Galapagos. As you might imagine, the 3,000-mile trip from there to French Polynesia was pretty miserable for her, so Peter, a lifelong sailor, volunteered to singlehand to New Zealand while Antonia flew on ahead. His trip turned out to be a bit more challenging than he'd imagined.

**Day 1, 1400** — Raised anchor at 0930 with no problems. I was anxious about the Taapuna pass but it was fine. Had to motor through a lot of rowers and local boats out to watch the surfers. Raised the main just outside the pass and motor-sailed in light SSW winds until

1300 then set the main and jib, and let 'Cheeky' take over. (Ed. note: 'Cheeky Little Bastard' is Peter and Antonia's nickname for their well-worn, second-hand Monitor windvane.)

**Day 2, last 24 hours: 131 nm** — Great sail first night! 15-20 knots off the port quarter, and I didn't touch Cheeky all night. Repaired the Monitor wheel attachment this morning, as one of the hose clamps had rusted and busted.

Then I had my first disaster dinner, Campbell's cream of mushroom soup. If I had just neglected to add the water it probably would have been a hearty stew-like substance, but then I also went on deck and promptly forgot about dinner. At first I thought the smell was an electrical fire.

A gray brown bubbly material, much like concrete, remained in the bottom of the pot. Good news, though, the stove is definitely working better.

**Day 3, last 24 hours: 129 nm** — Big news! I'm fucked! Last night at 2100 as I was lying down for a nap *Rei-Rei* (Sereia) jibed. I leapt out of the rack and was on deck in a

flash. I disengaged Cheeky and corrected course. Then I looked at Cheeky and noticed that he wasn't moving right. I checked him out, only to find the water paddle was gone. Not broken or dangling, but gone. I just stood there dazed, then I began to realize the horror: 2,700 nautical miles of hand steering. I sat down on the helm box and began to sweat.

Just then the wind started to pick up

and the waves that had been building all day really looked menacing. By 2200 it was blowing 25 knots, sustained. *Rei-Rei* was cooking along, but I knew I couldn't hand-steer all the way to New Zealand.

Luckily, it's simple to heave-to in *Rei-Rei*: you just roll up the jib, sheet in the main hard and turn the wheel in the direction of the wind. She'll sit fairly well like that in moderate seas.

So far it's not so bad. I steer until I get tired, then heave-to to nap and eat. Apart from the huge seas that sometimes crash into the cockpit, this is working out. When making way, we're doing 6's and 7's. Even though I hove-to for several hours I still made 129nm. The short of it is, I'm changing course to the Cooks. Only 400 nm, and then I'll figure out what I'm going to do.

**Day 4, last 24 hours: 93 nm** — Last night was hard. I had been on the helm for God-knows-how-many hours without a break. The winds were still in the mid-20's and I had been really ripping it up with *Rei-Rei*: she had enough speed to maneuver and dodge waves, sailing great. I didn't want to heave-to because the seas were large enough that even hove-to would be bumpy. When the fatigue got to the point where I was steering badly and I was starting to understand

Crowhurst's poetry, I had to stop. (Ed. Note: Donald Crowhurst was the infamous competitor in the 1968 Golden Globe race who went crazy and apparently jumped overboard after writing lots of bizarre poetry and other ramblings.)

It was terrible. I lay

"When the fatigue got to the point where I was steering badly and I was starting to understand Crowhurst's poetry, I had to stop."

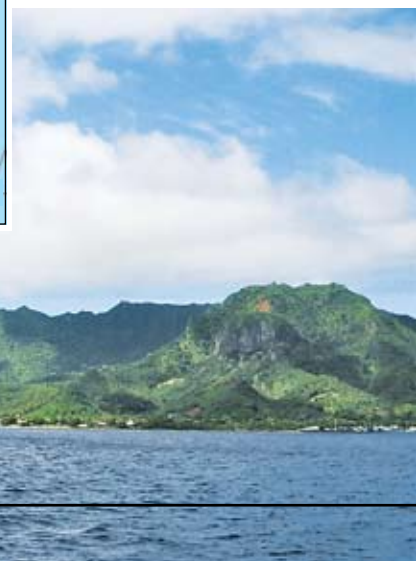
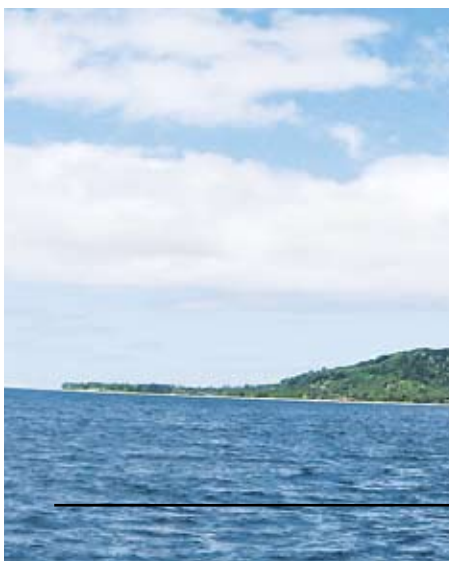
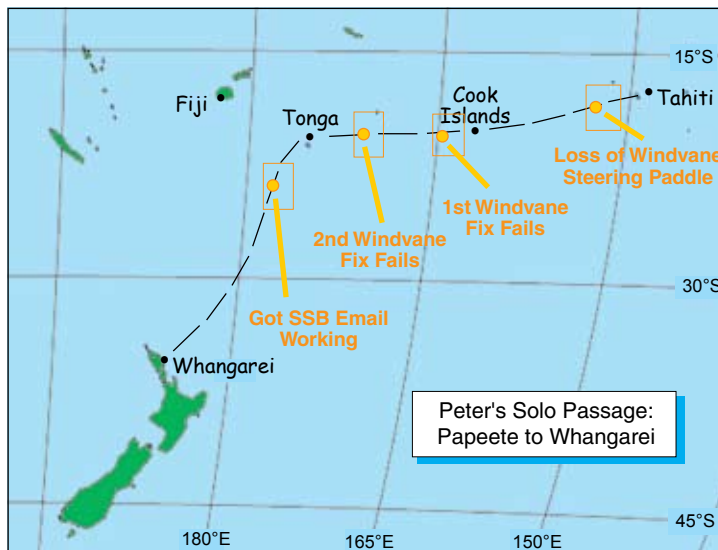

# — THREE CHEERS FOR 'CHEEKY'

in the rack for about 45 minutes getting thrown up in the air as *Rei-Rei* was smashed around by breaking waves. I got up again and went bleary-eyed back to the wheel. The next four hours were really weird. I didn't see frogs or hear children laughing, but I kept dozing off at the wheel, having split second mini-dreams about soft warm beds and my wife. Then I would lurch back into consciousness just before the jibe. This happened again and again. After four hours I was so off my rocker I hove-to again, hit the rack and was out for four and a half hours straight.

While I was out the seas calmed, and I woke up refreshed and ready to do it again. Only 262 nm to the Cooks!

**Day 5, last 24 hours: 87 nm** — "The sun will come out tomorrow. Bet your bottom dollar that tomorrow, there'll be sun. . ." Christ! I'm starting to sing show tunes.

The wind backed to the East last night, just enough for the main to blanket the jib, destination dead downwind. The evening became a game of keeping the jib filled, picking up speed and then bearing off back to course. Boy did that get old fast. The jib pole would have helped. Too bad it's busted.

Eating consists of running down below, grabbing something — anything — and running back to the wheel before the jibe. Ever try eating a dirty, raw potato?

When motor functions and mental

***Although Rarotonga, in the Cook Islands, looks pretty inviting from this angle, Peter decided to push on without stopping.***



ALL PHOTOS SEREIA

***Reunited in Whangarei. After falling in love in 2003, Peter and Antonia merged their dreams and assets, then set off around the world.***

acuity drop below an acceptable level it is time to sleep! Period! Full stop! The tricky part is finding that "acceptable level."

**Day 7, last 24 hours: 55 nm** — At about 2100 last night I was becalmed, no wind, nada. . . Rolled up the jib, sheeted in the main tight amid-ship and hit the rack for 8 hours. Woke up to a light 8 knots out of the northwest with flat seas. Set full jib and main, locked the wheel one spoke to starboard and haven't touched the helm in many an hour.

**Day 8, last 24 hours: 54 nm** — Rarotonga was a bust. Started the engine

about 0400, as I had been becalmed the whole night. Motored for 7 hours, radioed the harbor master about 10 times but received no response. Asked for a radio check and some guy answered, but he didn't offer info about the harbormaster. I did a drive-by of the harbor — what a shit-hole. All my fantasies about communing with the locals to fabricate a new water paddle melted away.

So. . . I bit the bullet and decided to pull a Moitessier. (*Ed. note: French singlehander Bernard Moitessier probably would have won the Golden Globe Race, but after rounding Cape Horn he opted to continue on to Tahiti rather than head north to the finish line.*) I took off the bow anchors and moved all 450 lbs of anchor chain out of the forward locker and stowed it under the salon table. Then I took all the weight I could find off the stern and bow and put it in the center of the boat, stowing it as

low as possible. *Sereia* has picked up half a knot already. Then I set a course to Tonga, only 850 nm to go!

**Day 9, last 24 hours: 118 nm** — My hard work from yesterday is paying off. Wind out of the southeast at 10-15 knots. *Rei-Rei* has never moved like this! The hobby-horsing is reduced, and she is cutting through waves rather than bouncing over them.

I'm able to consistently steer with the sails for the first time: I can pick my course and carefully set the sails. First I set the main, then the jib so she is balanced just right, then I lock the wheel to the center line. Small corrections can be made with miniscule wheel moves. She swings 15-20 degrees either side of





# WILD RIDE TO WHANGERAU

course but hasn't jibed yet. The track from last night was definitely inebriated but not drunken.

The one downside to moving the anchors and chain and fuel and air tanks and everything else is that the only place left on board for living is the nav-station, part of the galley and a small section of the main cabin to sleep.

I knew the weight re-distribution would help, but *Rei-Rei* is like a different boat. 750 nm to Tonga!

**Day 10, last 24 hours: 97 nm**—Tough night. The wind backed to the east and a chop came up, so I couldn't balance *Rei-Rei*. I was up pretty much all night steering. But this afternoon I had a break. I thought about the windvane, and figured out a way to fix it. Since the water paddle broke off at the top weld — it had been in a collision previously — the shaft that connects the paddle to the wind vane was still there. I took the shaft off and attached it to the centerboard from our old Tinker sailing dinghy. It took me most of the day to figure out how to do it, but the epoxy is drying as I write this. If all goes well, in the next hour I'll be napping and Cheeky Little Bastard will be up and running.

**0630** — The first incarnation of the new water paddle lasted about 30 seconds before it snapped like a dried bone. I took what was left, basically a hunk of epoxy and wood, and bolted on the plastic centerboard from our Walker Bay sailing dinghy, *Jackson Erl*.

It has been several hours since the newest installation. Since then, I've had a nap and it still seems to be working. But I'm keeping my fingers crossed.

**Day 12, last 24 hours: 112 nm** — Too busy to write yesterday, as I was sleeping and watching movies and eating and stroking my functioning Monitor windvane. It reminded me of Antonia saying, "I love our Monitor. It's like having another crewmember who I don't have to cook for!" The new water paddle is working beautifully.

I had an exciting morning. At about 0430 I woke up with my face against the

bulkhead. The boat was heeled over with the port rail in the water. The wind was blowing in the mid 30's with horizontal rain and *Rei-Rei* — under full sail — was

heeling over so far she was just about stalled. I leapt out of the rack, donned my foulies, and shot up on deck. I rolled up the jib and put a double reef in the main. Once I got her moving again under main alone, I let out a little bit of jib and we were flying — making 6 and 7 knots upwind.

The squall was out of the Southwest,

*"I'm not stopping! What would I do there? Wait for good weather? Well, it's pretty damned good right now!"*

just about where I wanted to go, but *Rei-Rei* was doing great. With her new weight distribution, she can actually sail upwind. I'm so proud.

**0700** — The wind died at sunset, so I motored. It had been a week since I last ran the engine. After about three hours I shut down the engine and went to bed. Woke up every couple of hours to watch the boat go backwards at about 1-1/2 knots, which was discouraging. Lousy sailing, but great sleeping.

At sunrise the wind came up again, and we were doing 3.5 to 4 knots — which would have been 4.5 to 5 knots without the head current.

What's up with the current going the wrong way? Hope it's just an eddy.

**Day 13, last 24 hours: 46 nm** — Very little wind all day. I've been fighting for every mile. Head current continues. Just started doing over 4 knots consistently. Going to try to head back north a little to see if I can pick up the Trades again. It's going to be a long journey if I keep making 50-mile days. I haven't seen one

south and we're moving again. One of the three hose clamps that holds Cheeky's wheel assembly on the helm busted off twice last night. The hose clamps don't seem to be up to the job. I've put two new ones on, but they keep breaking. I hope the increased strain on the steering system that's being caused by the jury-rigged water paddle doesn't do any other damage. Cheeky has been over-steering like a beginner helmsman since the paddle fix. Well, it's either this or hand steer.

**0350** — Raining, wind died again, doing 1.5 knots. Man, this is going to be a long trip.

**Day 15, last 24 hours: 67 nm** — 2 knots, 3 knots, 2.5 knots, slogging, 2 knots. Very little wind, shifting around the compass. Obviously, I'm out of the Trades. I'm heading a little more north, so hopefully I'll pick them up again. I have to work for every mile.

**0040** — Well, that was exciting. At about dusk, Cheeky busted again. God broke the plastic water-paddle just below the bolts. So I resigned myself to hand-steering the rest of the way to Tonga. . .



**Short-lived fix #1:** The centerboard was bolted and epoxied onto the water paddle shaft — which a collision had weakened.



**Fix #2 incorporated the centerboard from a Walker Bay dinghy. It lasted five days before snapping in two.**

contact since 50 miles out of Papeete. It's a big ocean.

**Day 14, last 24 hours: 96 nm** — Finally, the wind came up from the

not!

This is the first good wind I've had in days: SSE between 15 and 20 knots — perfect.



# — THREE CHEERS FOR 'CHEEKY'



**Peter arrived at Whangarei weary, yet elated. No doubt, 'Sereia's wacky paint job made her a standout in the anchorage.**

I busted out the tools and fixed the Little Bastard again, better and stronger this time. I'm getting used to hanging off the back of the boat in the dark, repairing broken shit.

**Day 16, last 24 hours: 110 nm** — Had a good sleep and a big bowl of pasta, then watched *The Life Aquatic* yet again. The



**Fix #3, using the undamaged lower portion of the centerboard, lasted for the remainder of the trip.**

wind continues to be perfect, 15 to 20 knots out of the southeast; SOG 5 to 6 knots. Cheeky seems happy, the shorter water-paddle is functioning better than

the old one, not as much over-steering. Only 150 nm to Tonga, and I'm going to have to decide soon: Should I stop?

**Day 17, last 24 hours: 145 nm** — The Island of Eua is visible off the starboard bow. It's the southernmost island in the Tonga group. I'm not stopping! What would I do there? Wait for good weather? Well, it's pretty damned good right now! I made 145 nm in the last 24 hours, and that's the best mileage yet this voyage. Cheeky is working.

I only have two main concerns. First, I don't have good weather info for when I approach New Zealand. The second is that I have a slight discomfort in the right side of my groin area. It is intermittent and I'm taking it easy. But it does kind of remind me of a hernia. Anyway, if I need another hernia operation I'd certainly rather be in New Zealand than Tonga.

1230 — Woke to a change in boat motion. Felt like a new wave train from an island. Checked the chart and found

I was 3.5 miles from a 40-meter sea mound. The bottom rose up from 1,600 meters to 40. I'm passing over a mountaintop and I can feel the change on the surface. Very cool.

**Day 19, last 24 hours: 100 nm** — It's been a mixed couple of days. The sailing's been perfect, winds southeast at 15-20 knots with little chop or swell, beautiful puffy white cumulus trade wind clouds. Unspeakably gorgeous sunsets and sunrises.

The downside is: something is up with my gut. I've been trying to lie down as much as possible, saving myself for the last couple hundred miles — when the gales hit. Only a little over 1,000 miles to go!

**Day 20, last 24 hours: 120 nm** — Just crossed the International Date Line, very exciting. Heard some clear calls to Russell Radio.

*Rei-Rei* has been great. She's sailing herself, not putting too many demands on me. I've been contemplating changing course to the south a little more. I'd save some miles but sacrifice some westing. Haven't decided yet.

My gut feels the same, so I'm taking it easy, trying not to strain or lift heavy shit. What a joke.

**Day 21, last 24 hours: 117 nm** — Great news! I used my voodoo to get the email working and got in touch with Antonia. So good to have some contact with her, even if it is just email. The SSB connection is shit so I don't know if I'll be able to contact her again, but she was able to send me some weather info and I grabbed some Grib files as well as a couple of text forecasts. Combined with what I've overheard on the SSB, all signs point south.

I've changed course to almost due south to Whangarei. Cheeky is holding up, my gut hasn't gotten any worse and I'm getting really hungry for some real food. Only 649 nm. Come on *Rei-Rei*, let's fly!

I just realized I have not seen a boat since Rarotonga, and that was a small motorboat. I hand-steered for over 500 miles and I never saw a tanker or anything. Granted, now that Cheeky is working I'm not on deck as much, but I still stick my head out every hour or so. I've gone over 2,000 nm without seeing a container ship, or fishing vessel, or cruiser.

**Day 22, last 24 hours: 130 nm** — An east wind at 15 to 20 knots for over 24 hours has given *Rei-Rei* a nice lift. Only five more days and I get to see my wife. I must admit I've truly enjoyed this rite of passage, but I can't wait to hold my



# WILD RIDE TO WHANGAREI

wife in my arms.

I haven't spoken to another human being in over 21 days. I don't feel like a hermit or recluse but, then again, how does a hermit or recluse feel? I don't miss people that much, although it would be nice to have a conversation with something other than inanimate objects.

**Day 23, last 24 hours: 142 nm**— That east wind just keeps on blowing. I'm making much better time than I had anticipated, but I don't want to jinx it. I've also been pressing *Rei-Rei* a little. I haven't reefed in several days and there have been a couple of occasions when reefing would have been prudent. But *Rei-Rei* just leaned over and went faster. She is a great beam reacher.

My gut feels better. I'm hoping that nasty little intestine has wormed back into place. It has been drizzling all day, exposing the many new leaks *Rei-Rei* has sprouted. It looks as though every port hole and window has a leak. Joy.

**Day 26, last 24 hours: 95 nm** — *Rei-*



*Antonia is a highly trained chef who typically makes fabulous meals aboard 'Sereia'. When Peter cooks, well... it's another story.*

*Rei* and I have been getting some wind the last few days. The Gribbs were right. Winds from the West at 25-30 kts. For the last few hours we've been close-reaching as the wind backed slightly to the south. Most of the time it's been a single-reefed main and one-third jib, doing between 4 and 5 knots. It's been pretty bouncy. Down below is a complete wreck and most everything is soaked.

Every time I grab the winch handle I have a mantra I repeat to myself: "This is gold, this is gold, this is gold." It's the only winch handle on board. The other one went in the drink when I was reefing on Day 2.

Saw my first traffic in 24 days, a big commercial vessel coming out of Whangarei. The turning block for the control lines on the Monitor has busted — perfect timing really. I'll be in port in 12 hours. Spotted Poor Knight's light, only 50 miles to go!

**Day 27, last 24 hours: 57 nm** — By the time I'd cleared customs, I was exhausted, as I hadn't slept at all the night before. When I stepped off the boat at the Town Basin Marina and into Antonia's arms, it was pure elation. After 26 days, it felt so wonderful to have my arms around my wife.

— peter murphy

*Peter and Antonia encourage you to check out their website: [www.svsereia.com](http://www.svsereia.com). The baby is due this month!*



## Tradewinds Sailing School and Club

1230 Brickyard Cove Rd #100, Point Richmond, CA 94801

Phone: (510) 232 - 7999

Email: [staff@tradewindsailing.com](mailto:staff@tradewindsailing.com)

**"The Best Sailing and Training Value on the San Francisco Bay!"**

### American Sailing Association School

#### Basic Keelboat (101) - \$525

January 12th  
January 14th  
January 19th  
January 23rd  
January 26th  
February 2nd  
February 6th

#### Basic Coastal Cruising (103) - \$675

January 19th  
January 28th  
February 2nd  
February 16th  
February 25th  
March 8th  
March 12th

#### Bareboat Charter (104) - \$895

March 8th  
March 22nd  
March 26th

**\*\*Dates listed are class start dates. 101 and 103: Weekend classes are 4 days. Weekday classes are 3 days. 104: Class is 3 days with overnight.**

**Our club members enjoy unlimited sailing for one low monthly rate!**

**Winter Special!**  
**Take \$200 off any of the above courses!**

\*Expires 2/29/08

**[www.TradewindsSailing.com](http://www.TradewindsSailing.com)**

# Emeryville Marina



ON THE BAY

**NEW SLIPS!**

**40-65' Available Now  
Call Today...**

*When you call Emeryville Marina Home...  
...call this your backyard!*



**Full Amenities  
including  
Fuel Dock & Pumpout Station**

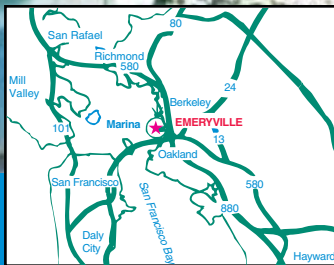

**MARINAS<sup>™</sup>**  
International

**(510) 654-3716**

[www.emeryvillemarina.com](http://www.emeryvillemarina.com)



**We help make  
El Salvador  
worth the trip!**

Visit our Web site  
[www.barillasmarina.com](http://www.barillasmarina.com)  
to learn more about our  
many amenities including  
high speed Internet,  
on-site customs and  
24-hour security.



Barillas Marina Club is the premier cruising destination in El Salvador.

We are Located in Jiquilisco Bay, the largest Bay in El Salvador.

Make Barillas Marina Club your headquarters in Central America  
and experience the difference that makes us a preferred destination.

[www.barillasmarina.com](http://www.barillasmarina.com)

**(503) 2632-1802 • [info@barillasmarina.com](mailto:info@barillasmarina.com)**



**INCREDIBLE SAVINGS ON FUEL AT MARINA CORAL!**

**Call for a quote ~ 866•302•0066**



- The only fuel dock & best launch ramp in Ensenada
- Concrete docks from 30' to 65' with 110v/220v elect., water, cable TV, phone service and wireless Internet, laundry, marine chandlery.
- Enjoy the amenities of the 147 ocean view suite resort which will make your stay the most enjoyable.

[www.hotelcoral.com](http://www.hotelcoral.com)

Reservations toll free **1-866-302-0066**

E-mail: [marina@hotelcoral.com](mailto:marina@hotelcoral.com) Fax-011526461750058 VHF 71  
Carretera Tijuana-Ensenada Km. 103, No 3421 Zona Playitas, Ensenada, B.C. C.P 22860



# EXPLORING THE

About 40 years ago, my good friend and mentor, Hugh Jacks, took his big yawl *Altura* on a cruise up the Mendocino Coast, the area north of Tomales Bay. The small, exposed coves there were once bustling hubs of activity during the 19th-century lumber trade, but are rarely visited by sea in modern times. Hugh's purpose was to examine these little nooks and coves where the 19th-century lumber schooners loaded redwood timber to ship to San Francisco and beyond. He came back with a wealth of color slides which, when combined with old black and white photos, made up one of the most interesting programs I have ever seen. Ever since, I have thirsted to repeat his trip and recently accomplished a good portion of it in our little Aries 32 *Misty*.

When the first Americans came to the Mendocino Coast in the 1850s, they discovered an astonishing wealth of timber in the magnificent groves of *Sequoia sempervirens* that grew along the Sonoma and Mendocino County coasts. At the time, there were no roads or railroads through the rugged country, so the only practical way to exploit the bounty was to locate sawmills on the coast — usually at the mouths of small rivers — and transfer the cut lumber to schooners at tiny, exposed anchorages often referred to as “dog holes.”

‘wire chute’ whose high end was rigged ashore, with the ship at the lower end. Bundles of timber were delivered via a



wire ‘high line’. Because the schooners had no auxiliary engines and there were no tugs available, an extraordinary degree of seamanship was necessary to maneuver them into position, then get underway again with huge loads of timber stacked below and on deck. Although the schooners eventually got small engines, then bigger and bigger ones (and their sail plans shrank accordingly), the degree of seamanship required to ply the dog hole coast was still extraordinary.

My first attempt to explore the dog hole coast began in early September of 2006 with my friend Dee Bowman of Mill Valley, when the winds were — supposedly — going to be light and the seas smooth. Armed with the large-scale chart (18626) of the coast between Elk and Fort Bragg, U.S. topographical maps of likely anchorages, and George Benson's excellent little guide *Cruising the Northwest Coast*, we sailed out the Golden Gate and up to Drakes Bay for an overnight stop, then on to Tomales Bay in company with a small yacht club cruise fleet. Proceeding on our own from there, we stopped at Bodega Bay, then headed north about 20 miles in heavy fog to our first dog hole anchorage at Fort Ross. Except for the worrisome presence of a rock in the middle of the cove that's shown on some — but not all — charts, the anchorage was mostly clear of kelp and smooth enough for us to row ashore in the dinghy to check out the historic Russian fort. A modest swell was coming around the point, so we set my homemade flopper-stopper from the spinnaker pole, which eased the rolling.

The next morning greeted us with a much bigger swell running and a light but rising breeze, with everything shrouded in dense fog. We quickly decided that the conditions didn't look good for our next

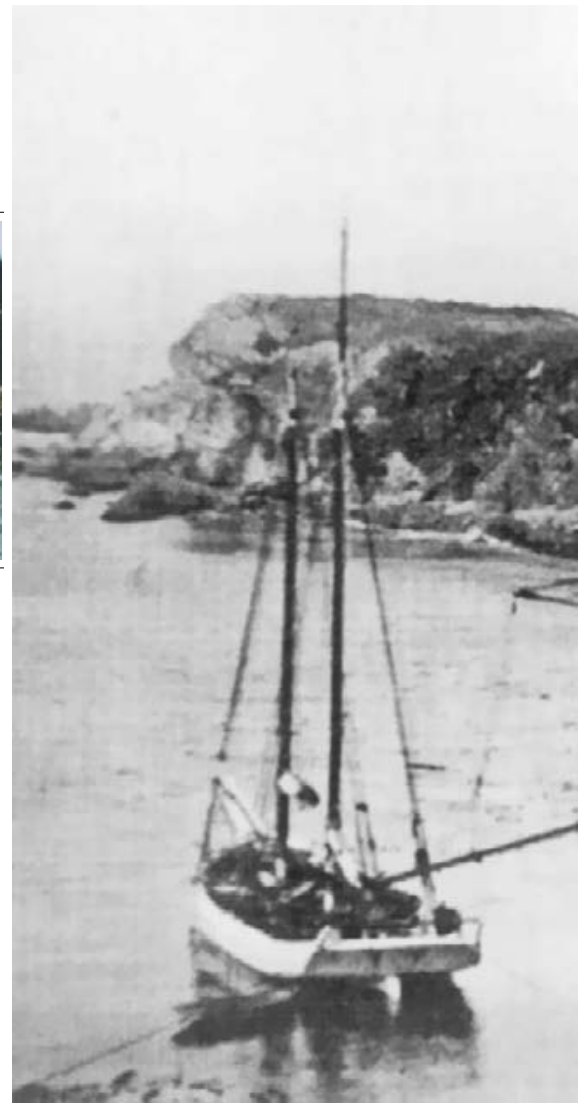

dog hole, Fisherman's Bay, which we believed was probably too small for comfort. So we headed on up the coast for Arena Cove, arriving in the late afternoon.

To our dismay, we saw a couple of small moored fishing boats pitching and rolling wildly, and a pair of guys in wetsuits surfing . . . in the anchorage. We tried setting the anchor a couple of times in the indifferent protection of the cove, but the bottom seemed to be gravel and gave poor holding. Obviously, this was no place to spend the night, so with few other options, we started up around Point Arena and headed for Cuffey Cove, just above the little hamlet of Elk. By the time we arrived, it was almost sunset, the coast was again hidden by fog and, without GPS, I don't know how we would have found it. Luckily, the fog lifted a bit just as we approached the shore, and we were able to identify some of the huge rocks guarding the entrance.

We tried to stick our nose into a nar-



Since there were no wharves or piers, timber was loaded on anchored ships via an elaborate and ingenious cantilever

# DOG HOLE COAST



*Plying the North Coast, then and now. Above, a lumber schooner in a North Coast 'dog hole' gets loaded via a long wooden chute. Above left, 'Misty' at anchor in Little River. Near right, Dee Bowman enjoying lunch on the fantail in 2006. Far right, working a slightly busier fantail in the old days.*

row portion of the cove known as Cuffey Inlet, but quickly saw that it was far too narrow, not to mention those surging waves going in and out. In the fading light, we picked out what appeared to be a safe spot in the middle of the main cove and carefully set the anchor, which fortunately got a good bite into the bottom. An uneasy night followed, with the boat rolling heavily and the wind piping through the rigging. We wondered if the iron men of old got as little sleep as we did on such a night.

The next morning revealed a low, dark, gray sky, a big swell and a weather forecast of gale force winds with gusts to 40 knots and hazardous seas. We had little confidence in our present location, nor the planned next one, Noyo Harbor, 40

miles to windward. Even if beat ourselves up getting there, we had no assurance we could get over the bar. We decided discretion was definitely the better part of valor. We weighed anchor and turned south for the 65-mile run back to Bodega Bay.



By midday, the sky had cleared, but the wind and seas were in full heavy weather mode. I had no way to accurately measure the wind velocity, but estimate it was at least 40 knots in the gusts which, combined with truly impressive seas, made steering a considerable chore and even overpowered our Monitor windvane at times. On a couple of occasions, we took sizeable seas over the stern which, though not dangerous, drenched the crew. We rounded Bodega Head at sunset and tied up to a battered fishing boat in the windswept harbor, thoroughly exhausted. We lay over at Bodega Bay for another day to let the wind die down, then headed for home via Drakes Bay, promising ourselves we'd try again next year.

**T**he next attempt in mid-September, 2007, turned out to be a solo cruise — not by choice, but because my crew was forced to drop out with a bad back shortly before departure. As in the previous year, *Misty* joined a small yacht club cruise fleet to Drakes Bay and on to Tomales Bay. I laid over an extra two days in White Gulch near the entrance to Tomales Bay because of very windy weather, and barely got over the bar on the third day because of the swell that had built up. By the time I reached Bodega Head, it was obvious that it would be foolish to go farther into the face of the rising wind and the big confused seas and swell, so I entered "Blowdega Bay." I spent two more windy days waiting out the weather, once



again trying to imagine how many schooners had done the same in the old days.

Finally, on September 20, the weather settled down, so I got underway for Fisherman Bay, a little dog hole about 12 miles north of Fort Ross. With



# EXPLORING THE DOG HOLE COAST

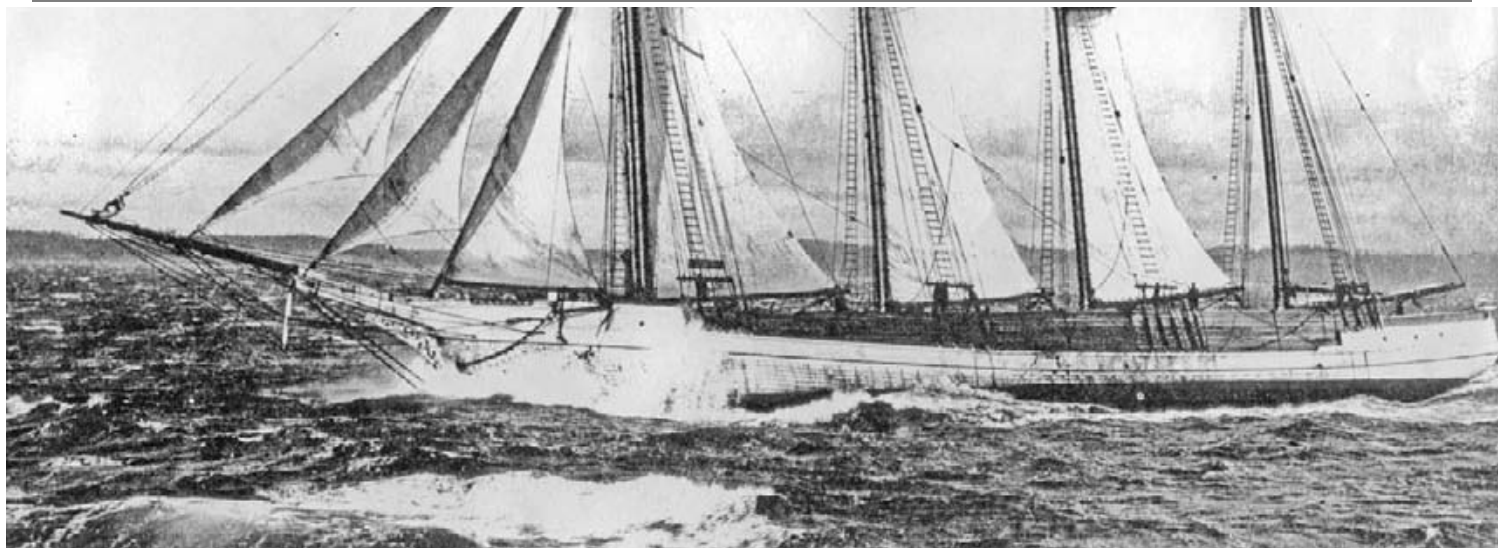

some difficulty, I identified the little cove and cautiously entered to discover that the most sheltered part of the anchorage, the northwest corner, was choked with kelp. With sizeable waves breaking over the rocks, and rather skimpy shelter in the middle of the tiny cove, there was a strong temptation to leave, but I decided to anchor and stay.

Despite the rolling and the noise of the breakers, it turned out to be a delightful spot in the afternoon sunshine. It occurred to me that I might have taken a few more clues from Benson's book, especially the photo that showed the author's boat with a full panoply of anti-rolling devices deployed, including a riding sail, flopper-stopper on a spinnaker pole and a stern anchor. In the evening, I solved the noise problem by closing the hatch and turning up the volume of my Gilbert and Sullivan CD. How those old lumber schooners managed to get into and out of a place like this was hard to imagine.

**T**he next morning I got underway early, intending to go 45 miles to the mouth of the Albion River, which was a dozen miles above Cuffey Cove — the farthest north we had gotten the year before. Except for some patchy fog, the weather was good with only a modest breeze, but there was still a big, confused swell running. By early evening, the sky was heavily overcast but the visibility was good, so I had little difficulty finding the buoy which marked the entrance to the river. I made my way into Albion Cove by passing uncomfortably close to Mooring Rock, which guards the entrance. The cove was nicely sheltered from the waves and swell, but was cluttered by that abomination of modern cruising: unused private mooring buoys. Still, it was a very picturesque spot with houses atop the cliff overlooking the

***Talk about iron men! — magnets must have stuck to the guys who sailed the lumber schooners in and out of dog holes in the old days. And they didn't stop for something as trifling as winter. This is the four-master 'Fearless' heading up-coast in a blow with lumber piled high on deck. The last survivors of 900 ships that plied the lumber trade are the dilapidated steam schooner 'Wapama' (currently not open to the public) and the Maritime Museum's 'C.A. Thayer' at Hyde Street Pier. The 'Thayer' also holds the distinction of being the last commercial sailing vessel to operate from a West Coast U.S. port.***

anchorage and an impressive, very high bridge over the river just above the cove. I had seen an old photo of the huge sawmill on the level area just above the bridge which is nowadays just a trailer park.

After a peaceful night's sleep, I inflated the dinghy and went for a row up the river. Upon my return, I got underway for the next dog hole, Little River, 15 miles north. The big mixed swell from the northwest and southwest was still running, which made my exit from Albion (and the entrance past the rocks into the Little River anchorage) very exciting, but once inside, it was smooth. I anchored near the beach at Van Damm Park, which on a Sunday was covered with happy beachgoers and kayakers. It was a pleasant scene, but once again hard to imagine how it might have looked in the old days. By evening, the wind shifted into the south and it began to spit rain — not a comfortable situation considering there was virtually no protection from that direction. I moved out from the beach and re-anchored, then crossed my fingers and hoped for the best.

**I**n the morning, there was only a light breeze from the northwest, but if anything, the confused swell was even bigger. I had planned to visit Russian Gulch — described in the *Guide* as “the

gem of the Mendocino Coast,” but when I arrived opposite the cove, the entrance was a frightening welter of big breakers. Perhaps I would have been bold enough to enter if I'd had a crew aboard, but honestly my courage failed me, so I decided to continue on to Noyo Harbor and visit ‘the gem’ on my way back.

Noyo Harbor lies about a mile beyond the high bridge spanning the entrance, and is a delight with its setting along the high wooded banks of the Noyo River. The place is crowded with busy fishing boats and echoes with the barking of many well-fed sea lions. The weather was sunny and calm and several cruising boats were in residence, which made for a lively social scene.

After two pleasant days, I started back, leaving the harbor early in company with a Coast Guard boat out on dawn patrol. But the blasted big, confused swell was still running high, and I once again cancelled my plan to try to get into Russian Gulch. I felt doubly humbled by the fact that the old schooners operated in all seasons with (in the early years) no engines, and here I was in the best season and had a handy little sloop with an auxiliary engine.

By noon I easily entered Cuffey Cove. This time it was delightful, with sunny skies and only a mild breeze as I anchored off the rugged cliffs.

**F**rom there, it was another day running before light following breezes to Bodega Bay, and one more of easy down-wind sailing before I was back in the Bay. It had not only been a rewarding two-week cruise in itself, but a sort of trip back in time that gave me a vast appreciation of the seamanship of the sailors of those old schooners.

— bob van blaricom



# MARINA BAY YACHT HARBOR

*A Certified Clean Marina*

**(510) 236-1013**

[www.MarinaBayYachtHarbor.com](http://www.MarinaBayYachtHarbor.com)

1340 Marina Way South  
Richmond, CA 94804



- Berth to Bay 15 Minutes
- Single Load Concrete Docks
- Deep Draft Harbor
- Nearby Boatyards, Marine Stores and Fuel Dock
- Wireless Internet
- Reserve Space For Your '08 Club Cruise!

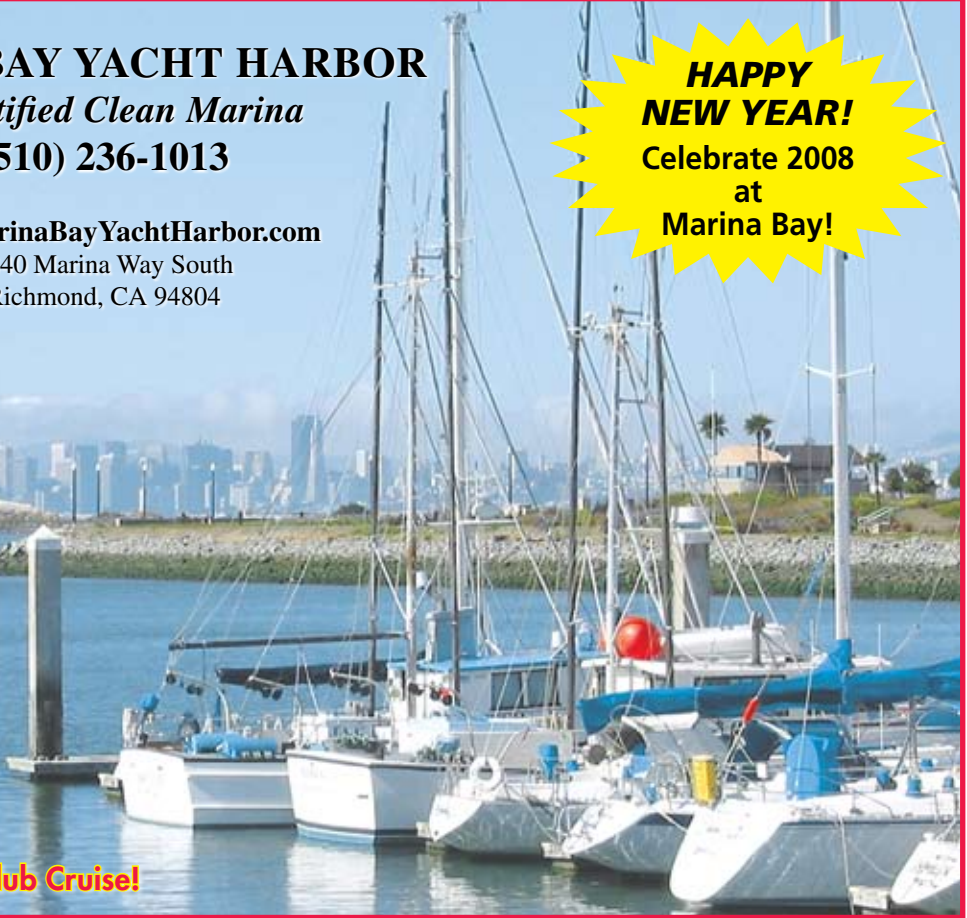

## McGinnis Insurance

*Since 1972*

**Knowledge ⚓ Commitment**  
**Reliability ⚓ Service**

*Happy New Year!*



*Large and small, we do them all!*

Call us at: **800-486-4008**

[mcginnsins@aol.com](mailto:mcginnsins@aol.com)

License #0570469

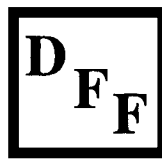

## DIESEL FUEL FILTERING

*since 1989\**

*Superior equipment and years of experience guarantee results - Don't settle for less.*

### **Purify Diesel Fuel & Flush Tanks.**

Process scrubs; polishes; removes algae, dirt, rust and water from diesel fuel.

Includes internal tank washdown.

Save your injectors, costly engine repair and down time.

*We are in compliance with State and Federal Specifications & pollution control.*

- "All Pleasure Yachts & Commercial Craft."
- Your berth or boat yard.
- Fully Insured

**(510) 521-6797**

Fax: (510) 521-3309



\*Owned and operated by Bob Sherman since 1989



# PIRATES FOR PUPILS

The first annual Pirates for Pupils Banderas Bay Blast more than lived up to its name, as the crews of 29 boats amicably went at it in ideal beating, reaching, and running conditions over a three-day period in early December. And they raised just under \$3,000 doing it.



**Having cheated death, Commodore Eugenie photographed the Punta Mita Yacht & Surf Club membership cards.**

The Pirates for Pupils was previously a one-day spinny run from Punta Mita to Paradise Marina just prior to the start of the Banderas Bay Regatta in March of each year. But with that latter event becoming part of Nautico Week, along with MEXORC and other activities, and with the Wanderer, who founded Pirates for Pupils, wanting to expand the event to publicize the wonderful sailing conditions and destinations on Banderas Bay, the P for P was moved to early winter. And to kick it up a notch, the Wanderer invited the Vallarta YC to become a co-sponsor, and to try to create a little buzz, make a feature of the event a supposedly 'bad blood' duel between *Latitude's* 63-ft Emiliano Zapata-based cat *Profligate*, sailing for the Punta Mita Yacht & Surf Club, and John Haste's Panama-based Perry 52 cat *Little Wing*, sailing for the Vallarta YC.

The 29 participating sailboats ranged in size from Randy Hough's Black Cove 29 *Sweet Lady* in the Fun Class, to Dave Crowe's M&M 70 cat *Humu Humu*, but also included a couple of powerboats to prove that sailors don't discriminate. The overwhelming majority of the participants and boats were Ha-Ha veterans of the last several years, so many of the participants knew each other and were familiar with the 'nothing serious' culture. Making the fleet rather unusual was the presence of six big — 45 to 63-ft — cruising cats. It gave everyone a unique opportunity to see how very different the cats were in design and construction, and how differently they performed in the different wind conditions.

To get away from the windward-leeward racing that has little appeal for most cruisers, the three 'races' were all to destinations rather than around the buoys. The first leg was a light air reach from just off Paradise Marina to the seven-mile distant Riviera Nayarit Marina at La Cruz. With *Profligate* having had a long history of getting drubbed in the light air first legs of Banderas Bay races because of her tiny headsail, the supercargo had the crew set the big asymmetrical chute from the leeward bow in order to try to sail as high as possible while still carrying that sail. He didn't care that this resulted in their pointing to the beach rather than the mark, he just wasn't going to be underpowered again. But it's better to be frustrated and lucky than good, as the big cat — the only one to hoist a nylon sail — was progressively lifted to lay the finish line by the narrowest of margins.

One of the refreshing things about life in Mexico is that people aren't so risk adverse. For example, could you imagine the management of an unfinished 400-berth marina in the States allowing 29 boats and 100 crew in to mix with their 600 construction workers? Well, it wasn't a problem for Christian Mancebo, a partner in the Riviera Nayarit Marina, who not only welcomed the entire fleet with

The 29 participating sailboats ranged in size from Randy Hough's Black Cove 29 *Sweet Lady* in the Fun Class, to Dave Crowe's M&M 70 cat *Humu Humu*, but also included a couple of powerboats to prove that sailors don't discriminate. The overwhelming majority of the participants and boats were Ha-Ha veterans of the last several years, so many of the participants knew each other and were familiar with the 'nothing serious' culture. Making the fleet rather unusual was the presence of six big — 45 to 63-ft — cruising cats. It gave everyone a unique opportunity to see how very different the cats were in design and construction, and how differently they performed in the different wind conditions.



**Spread; Robin and Michelle Bendall, a couple of research scientists from Santa Cruz, and their daughter Melissa, in from Australia, head toward the Punta Mita finish aboard 'Warrior', their 50-ft German-built wood boat. Insets, clockwise from above; Jim Forquer's *Cantana* 52 'Legato' leads 'Capricorn Cat' and 'Little Wing' away from La Cruz. Peter Boyce gets a sweet kiss to celebrate his 75th. Jim Taylor of 'Sooner Magic' wants you not to miss the P for P next year. He ran over 700 races for the St. Francis YC in his day, and rarely saw Banderas Bay conditions on San Francisco Bay.**



# BLASTS OFF ON BANDERAS BAY

free berthing, but threw a little beer bust amongst the workers laboring at the site of the to-be yacht club. Fortunately, the P for P folks did their part by not getting hit in the head by cranes, run over by cement trucks, or impaled on unmarked rebar. Recent progress at the marina, which has a beautiful location, has been swift, so it will probably be up and run-

ning by the time you read this.

**O**f course, no sailor visits La Cruz without stopping at Philo's Restaurant and Bar. Philo Hayward is the guy from Mendocino who did the '00 Ha-Ha aboard his Cal 36 *Cherokee Spirit*, fell in love with La Cruz, but continued across the

Pacific to Vanuatu before selling his boat and returning. His drinks were cold and strong, the dinners were delicious, and the music was better than ever that night. The song of the evening was *Happy Birthday*, sung for Peter Boyce of the Manteca-based Sabre 402 *Edelweiss III*, who along with his crew had flown down just for the charity event. What's next on the 75-year-old's schedule? Put-





# PIRATES FOR PUPILS



ting all his energy behind the cruisers' Zihua Sail Fest charity event at the end of January.

If anybody wants to understand the difference between a beat on Banderas Bay and a beat on San Francisco Bay, they should have been there for the 10-mile second leg from La Cruz to Punta Mita on December 8. It blew 20 knots on Banderas Bay, as it usually does on San Francisco Bay, but there was no chop because there was so little fetch. Even more important, it was also about 35 degrees warmer on the course in Mexico, so nobody even thought of wearing foul weather gear. On some boats — we won't mention *Capricorn Cat* by name — there wasn't a t-shirt's worth of fabric covering the entire eight-person crew.

The race was tactically interesting, too. Those who started by sailing the off-shore tack quickly became toast, as the further they sailed, the worse a header they would have to tack back into. For those who hugged the north shore, the

goal became trying to clear the point while making the fewest tacks possible, but also without hitting any rocks on the relatively shallow and uncharted bottom. After some exciting port/starboard situations in about 12 knots of wind, the leaders of the fleet made it around the last rocky outcropping to find as much 21 knots of warm wind to play in. Despite some intermittent lulls and wind shifts toward the end, it was an idyllic upwind leg. Looking good approaching the Punta Mita finish was Jim Casey of Tahoe City, who celebrated a birthday of his own driving his Jeanneau 43DS *Tomatillo* across the line. He didn't reveal his age, but Doña de Mallorca said "he doesn't look a day over 49" to me.

While the huge swell of the previous two days had mostly dissipated, there were still enough waves for some sailors to do some surfing not 100 yards shoreward of the P for P fleet anchored



*Clockwise from top left; Rob and Tania Ritchie's beautiful Bristol 49 'Indigo'; Pirates — not 'pilots' — for Pupils!; the J/160 'Blue' on a beat; Katie, the most stylish pirate of them all; Jim Casey at the helm of 'Tomatillo'. Tim and Kim of 'Hawaii's Eau de Vie'. Wayne and Carol of 'Capricorn Cat'. Heather and Mary Forest of 'Cap Cat' give a safety demonstration at the end of the Punta Mita leg; Christian Mancebo of the Nayarit Riviera Marina. Bottom two photos: Tim Taylor on the high side of the San Rafael-based 'Sooner Magic', and Jan and Vivian Meerman of 'Capriccio' — who "blame" Latitude for their having so much sailing fun in Mexico.*



# BLASTS OFF ON BANDERAS BAY



at Punta Mita. Most, however, were just pleased that Rod, owner of the splashy new Swimmer's restaurant at the western end of Punta Mita's waterfront restaurant row, had arranged for *pangas* to shuttle pirates between their boats and shore. If you haven't been to Punta Mita for a few years, you'd be flabbergasted by the changes. One thing remains the same, however, and that's the location of the Punta Mita Yacht & Surf Club — although the club officers let Hector use the facility as Margarita restaurant the 363 days of the year when the club isn't using it.

Not everyone was able to just kick back during the fiesta at the club. Commodore Eugenie Russell, who had cheated death by broken main halyard just the day before, was on a mission for



## PIRATES FOR PUPILS

charity. She patiently went from table to table, explained the purpose of the charity, and got most folks to throw in some extra pesos for the cause. But as per the club rules, she had to be firm with club memberships. Those who hadn't sailed to Punta Mita and/or who couldn't cough up the \$1 in lifetime fees had to be rejected.

Other big benefactors were Ronnie 'Tea Lady', who has been a mainstay of the P for P since day one; Mai Dolch of the Marquesas 56 *Dolce Vita*, who raised \$300 on her own; North Sails Mike, who donated the T-shirts sold to raise money; and many others.

The Yacht and Surf Club party was a great chance to spend time with old friends and make new ones. For example, it allowed us to catch up with South African friends Doug and Mary Solomon, who we'd spent some of the most laugh-filled nights of our lives with in Antigua in '91 and '92. Now on a new-to-them wood Aige Nielson 63-ft *Fandango*, we hadn't seen these still-sailing-in-their-70s folks in 15 years! Among the many new friends we met was Tim Dick, who



**Heather 'I won't ever do retail again' Corsaro and David Addleman of the Cal 36 'Eupsychia' jumped their ship to become pirates.**

owns the Beneteau 42S7 *Eau de Vie* on Kaneohe Bay, Hawaii, and who started the *Hawaii Superferry*. Tim was there with his lovely lady Kim Le of Sausalito, who had come down to Banderas Bay to brush up on her sailing skills at J/World.

One nice thing about sailing events with 100 or so people is that after the second day, just about everybody knows each other, and it's like family.

Most first-time visitors were impressed with Punta Mita. The shallow water anchorage could hold hundreds of boats, and the afternoon breeze is reliably offshore. In addition, there's often surf, there are good places to eat, the views of the point, the breaching whales and the four-mile distant Tres Marietas Islands are lovely, and the sunsets are spectacular.

After a couple of P for P skippers briefly snuck off the next morning to join Philo for his Sunday morning motorcycle ride, most members of the fleet gathered at Swimmer's for breakfast. We're not sure how long it's going to last, but despite having the most attractive digs on the beach just a winch handle's throw from the dinghy landing, Swimmer's had the lowest breakfast prices, too. We're working with Rod, the owner, to explore the feasibility of providing regular *panga* service between the boats and shore. The

# Buy Quality Sails Direct at 25-40% Savings!



It's the easy way to measure and order your own sails and SAVE! Premium fabrics, quality construction, unbeatable value. Order online or ask for our FREE catalog today!

**[www.cruisingdirect.com](http://www.cruisingdirect.com)**

Call 1-888-424-7328 for your FREE catalog

Fax toll free: 1-888-237-2457

MANUFACTURED AND SERVICED BY NORTH SAILS

**CD**  
**CRUISING DIRECT**  
**SAILS**

# BLASTS OFF ON BANDERAS BAY

restaurant also allowed Bill Finkelstein of the Santa Rosa-based Valiant 50 *Raptor Dance* to install the *Latitude*-donated wifi equipment to blast a wifi signal out to the anchorage. We were too busy to try it, but one user said that it not only worked, it was super fast.

The last leg of the Blast, the traditional 12-mile P for P Spinnaker Run For Charity back to Paradise Marina, was about as mellow as could be, with just enough windshifts and lulls to keep things interesting, and enough wind to keep the boats at close to hull speed most of the time. That kind of sailing, with warm sunshine, surrounded by jungle and tall mountains, accompanied by dolphins, rays, and turtles, was hard to beat.

Who won the Banderas Bay Blast? The 'bad blood' duel between John Haste's *Little Wing* for the Vallarta YC for Doña de Mallorca's *Profligate* for the Punta Mita Yacht & Surf Club, turned out to be a bust because the owners and crews of the two boats like each other too much for bad blood, and because *Little*

*Wing*, thanks to a mix-up with the diver, had a bottom as smooth as a shag run and couldn't get out of her own way. There's always next year.

The real winners, in addition to the charities, were the owners and crews of the following boats that participated: *Dolce Vita*, Marquesas 56; *Wind Trekker*, F-31; *Legato*, Catana 52; *Capricorn Cat*, Hughes 45; *Humu Humu*, M&M 70; *Little Wing*, Perry 52; *Profligate*, Surfin' 63; *Interlude*, Morgan 382; *Charissa*, Liberty 45; *Edelweiss*, Sabre 401; *Indigo*, Bristol 49; *Tomatillo*, Jeanneau 45DS; *Destiny*, Catalina 42; *Vinmar*, Ranger 33; *Warrior*, Chance 50; *Capriccio*, Sabre 38; *Capt. Geo Thomas*, C&C 30; *Bright Star*, Jeanneau 40; *J/World 80*, J/80; *Blue*, J/160; *Sooner Magic*, Beneteau 47.7; *J/World 120*, J/120; *Raptor Dance*, Valiant 50; An-



As 'not very serious racing' destinations go, it's hard to beata scenic Punta Mita, at the northwestern tip of Banderas Bay.

*dante*, Mystery 35; *Chere*, Beneteau 46; *Curare*, Bowman 36, *Sweet Lady*, Black Cove 29; *Paseitos*, power; *Vingaras Due*, power.

Like having a blast while sailing and raising money for charity? Then load up for next year's Pirates for Pupils, to be held at the same place at approximately the same time.

—latitude/rs



The VIKING advantage

## VIKING RescYou Pro™

- Your guarantee for ultimate safety

- Available in 4, 6, 8 person capacity
- Equipped with inflatable double floor
- Full Offshore (E-type) equipment Pack (Optional ISO Pack 1, Pack 2 or Solas B)
- Available in valise or low profile container with stainless steel cradle for rail or deck mount
- Worldwide servicing - over 300 USCG/SOLAS approved service facilities

Hailed Market's Best  
by Independent Sources  
• Three-Year Service  
Intervals

See Us at the Seattle Boat Show  
January 24 - February 2



VIKING LIFE-SAVING EQUIPMENT  
(America), Inc.

Please contact our local Viking dealers:

Sal's Inflatable Services	Alameda	(510) 522-1824
Coast Marine & Industrial Supply	San Francisco	(415) 673-1923
Oceans West Marine	San Diego	(619) 544-1900
Viking Life-Saving Equipment	Long Beach	(305) 614-5800





# SEASON CHAMPIONS, PART III —

Welcome to the third and final installment of our annual season champions feature. In the past two issues, we profiled the winners of HDA (November) and one design (December). This month — last but certainly not least — we introduce you to representative winners of the Wooden Boat Racing Association, the Singlehanded Sailing Society's (SSS) Singlehanded and Doublehanded season winners, the Wylie Wabbit champ and the Bay Area Multihull Association (BAMA) winner. We even have a few winners from a couple of the larger dinghy classes, the Vanguard 15s, as well as the El Toro Sr. and Jr. champions.

With the ups and downs of various fleets over the years, it always amazes us when we get to this point in the Champions process and realize that fleets like the Knarrs, Folkboats, IODs, Birds — and indeed the El Toros — have been racing more or less continually for more than half a century! And while their numbers vary up and down like everyone else's, new people continue to be attracted to the fleets. It has certainly helped that most of the larger classes just mentioned allow fiberglass hulls, but, more to the point, these fleets showcase all that is good about sailboat racing: good organization, spirited competition, good, enduring designs and — most important — fun, knowledgeable, helpful people within the fleets.

A perfect example is the El Toro family, which has nurtured more future champion sailors on our local waters than any other design. And continues to do so. From America's Cup skippers and round-the-world race winners Paul Cayard and John Kostecky to, most recently, 29er champion Max Fraser (and crew David Liebenberg), they all started in Toros. Not bad for a little plywood dinghy originally cobbled together by local sailors in 1939 as a yacht tender.

All of which takes nothing away from the Optimist class, which has also been the first large stepping stone for future sailing champions. And the Opti fleet has grown rapidly in Northern California, once again boasting 40-some boats in 2007, making it the largest junior dinghy class in the Bay Area. We heartily congratulate the repeat winner, 14-year-old Lauren Cefali, for her 2007 season win.

But this year, it's the Junior El Toro winner's turn for the limelight. Look for more on 'young gun' Patrick Tara's win in the following pages.

The other 'dinghy' class in our end-of-season lineup is the Vanguard 15s.



Started and based out of the Treasure Island Sailing Center since 1998, the V-15 fleet is one of the larger and more active of all local small boat fleets. They're so big they actually have season champions in two separate fleets: the 'regular' season champ, and the top team in their even better-attended Thursday evening series.

Over at YRA, while dwindling numbers continue to vex the one design and handicap divisions, the woodies (and 'glassies') of WBRA have maintained pretty well over the past few years. WBRA President Bob Thalman reports that 2008 numbers and classes will be about the same as last year, with around

55 boats spread over four classes: the Birds, Folkboats, IOD and Knarrs. It looks as though the latter — the largest WBRA fleet — may even get a new boat or two.

(Still notable by their absence is the Bear Boat fleet. One of the larger of all YRA classes as recently as 10 years ago — and, at 60-some boats, numerically still one of the biggest local fleets — the Bears went into a 'hibernation' of sorts after some of the old guard retired from racing. Many boats remain active, however, and some new blood is coming into the fleet. Hopefully, they can put something together for a grand return to fleet racing in 2009.)

There will be two big changes for WBRA fleets in '08. One is the move away

# WBRA, BAMA, SSS, DINGHY, ETC.



from starts off race decks and the use of RC boats instead. The second will be the emphasis on using offset windward marks and leeward gates by clubs having the capability to do so. "We also will be asking clubs to use inflatables wherever they are able to," says Thalman. "Don Wilson and I will be modifying the WBRA SIs to include these course options." Bob credits the Knarr Class for making these requests, which it's hoped will clear up congestion at mark roundings in WBRA's short windward/leeward courses.

If WBRA is maintaining well, the SSS fleet is positively exploding. 2007 marked the organization's 30th anniversary (it started in 1977, the same year as this magazine), and interest in the club, and in shorthanded sailing, has been

***Nice Folks — The first Folkboat went sailing in 1942. Fleets are still going strong here in San Francisco Bay and Scandinavia. Don Wilson's 2007 Season Champion 'Windansea' is the blue boat at right.***

steadily increasing. Last year saw 186 members and 340 boats racing SSS events, up 15% from 2006. The Society's Three Bridge Fiasco, with an amazing 297 boats last year, is one of the better attended of all events on the Bay — and it's in *January*. (Check out the website at [www.sfbaysss.org](http://www.sfbaysss.org) to help them break the 300 mark later this month.)

SSS Commodore Mark Deppe reports that most feedback to the club about their race program and excellent seminar series is, simply, "Keep doing what you're doing." But of course there's always room

for improvement. In that category for 2008 is replacing September's East Bay Estuary Race with a new course designed to avoid the heavy commercial shipping traffic in the Oakland Estuary. And, as a tentative step outside their racing-only mentality, "We're looking into an experimental 'cruise-in' event open to the SSS sailors, their friends, and families," says Mark.

**F**inally, to the fleets and 2007 season champions not mentioned in this series, our sincerest congratulations and accolades. We wish we had the space to feature you all. Keep up the good work and perhaps next year it will be your turn to appear in these pages.



# SEASON CHAMPIONS, PART III —

## **Knarr** **Three Boys and a Girl**



**Chris Perkins**  
**SFYC and StFYC**

Ever since he started in the San Francisco YC Junior Program back in the mid-'70s, Chris Perkins has been a force to be reckoned with in fleets ranging from the family's first boat — a Rhodes 19 Chris's father bought from Joe Madrigali — to his latest weapons of choice, the J/105 *Good Timin'* and the Knarr #141 *Three Boys and a Girl*. With the former, he won seven season championships in a row, as well as the J/105 division at the last Big Boat Series. With the Knarr (named for the combined progeny of himself and boat partner Hans Baldauf), he won the 23-race, 5-throut season, as well as the International Knarr Championships, an annual world championship of this 65-year-old class that rotates between host clubs in Denmark, Norway and here in San Francisco.

Chris's Knarr roots go back even further than his junior sailing at SFYC. "I grew up in and around these boats back in the '60s, crewing for guys like Grant Sedelmeyer," he recalls. "So when Hans and I were looking around for a relatively inexpensive but quality club racer, the Knarr was an easy choice." They originally had a wooden boat, but changed to the less maintenance-intensive fiberglass *Three Boys* about 10 years ago.

Chris, a CPA, attributes this year's win to the fine crew work of Baldauf, Hisham Sinawi and brother Phil Perkins.

The 'other' season for Knarrs is their intense Wednesday night series. Sean Svendsen won that in '07.

2) **Lykken**, Hans Williams/Rick Fisher; 3) **Snaps III**, Knud Wibroe. (18 boats)

## **Folkboat** **Windansea**

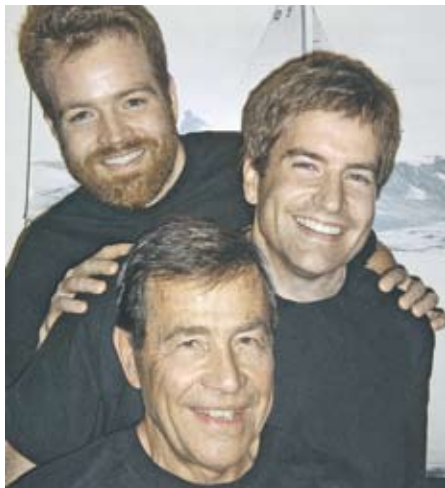

**Don Wilson & Sons**  
**Richmond YC**

After the birth of his second son, Daniel, in 1978, the doctor told Don Wilson — a Folkboat sailor since 1968 — "Now you have a whole crew." Little did he know how prophetic those words would be. In 2007, for the first time, Don, Dan and older brother David raced as a team — and won the Folkboat season championship. It was the first time for the younger Wilsons, and the second time for Don, who last won the same year Dan was born: 1978.

The younger Wilsons did more than just crew. After shoulder surgery put Papa Don on injured reserve in September, Dave and Dan (with 'thirds' Tom Urbania and Martin Leivers) bulleted three of their last four races to get *Windansea* into the winner's circle. In fact, out of the 19 races that the Wilsons attended, *Windansea* took 12 firsts, 6 seconds and 1 third — that's right, they never finished worse than third! This is one of the top performances of the year in any class.

And that's not all. With dad still sidelined by the healing shoulder, Dave helmed the boat to a win in the very competitive International Folkboat Regatta in September, beating masters of the game who came from as far away as Germany, Norway, Denmark and Sweden to compete. David also won the Folkie's long-running Wednesday Night series out of St. Francis YC. We think it's safe to say that *Windansea* is the new boat to beat in this fleet.

2) **Thea**, Chris Herrmann; 3) **Polperro**, Peter Jeal. (10 boats)

## **SSS Singlehanded** **Mirage — Black Soo**



**Ben Mewes**  
**SSS**

Ben attributes this year's win of SSS Singlehanded Division to "finally learning how to sail." He's obviously being a bit facetious. But a talk by former Singlehanded (and Doublehanded) season winner Mark Halman really did start him sailing smarter. Ben has owned the 30-foot foot Black Soo (a hard-chined Van de Stadt design built in the late '60s) for 18 years, and worked with Carl Schumacher to make a lot of little tweaks to the boat. And he's done a lot of sailing, both on *Mirage* and *Georgia*, a 40.5-ft sloop (also a Van de Stadt design) that he sailed to Hawaii in the 2000 Singlehanded TransPac. But only recently has he really concentrated on constant sail trim as the boat sails on autopilot. And it's paid off.

Ben says his biggest thrill this year was pursuing and eventually passing an Express 27 — a boat that gives him time — during last year's Singlehanded Farallones Race. "That was a real adrenaline rush," says Mewes, who was raised in Germany and immigrated to the U.S. in 1965. He currently makes his living as a contractor.

Ben's good fortune in the sailing arena pales to that in real life. In October, he underwent surgery to open a blocked artery. Ironically, a fellow SSS sailor, Rob Mayberry (who crewed on Steve Katzman's *Dianne*), died of a heart attack that same day. "I'm the lucky one," Mewes says, extending his condolences to Katzman and the Mayberry family.

2) **Travieso**, Ericson 30+, Dan Alvarez; 3) **Arowana**, Diva 39, Larry Riley. (29 boats)

# WBRA, BAMA, SSS, DINGHIES

## SSS Doublehanded Bad Puddy Cat — C&C 37



### Matt Siddens Sequoia YC

This is the second year Matt (left) and crew Chris 'Lou' Lewis have won SSS's Doublehanded Division, and Matt says it was decidedly harder than in 2006. They not only had to finish every race, they had to do well in every race, right down to the homestretch when they were so close in points to Darren Doud's F-31 *Roshambo* that whichever boat won the last race (the doublehanded half of the Vallejo 1-2) won the season. As with a couple other close calls over the summer, Matt and Lou pushed the old C&C to victory.

Their best race had to be the Three Bridge Fiasco, though. "We saw a lane of pressure outside at the start. Even though it was in adverse current, we gave it a shot — and ended up passing about 40 boats in 10 minutes," said Siddens, who works in the family cabinet-making business in San Jose.

When not sailing with each other, both Matt and Lou crew on other boats. Locally, they are regular crew on Lani Spund's *Kokopelli*². Farther afield, Matt recently returned from Florida, where he crewed on Tom Cassenberg's winning Melges 24 *Flygfisk* at the Key Largo Regatta, a tune-up event for this month's Acura Key West Race Week.

Matt and *Puddy Cat* boat partner Charles Watt (who does some singlehanded races) have decided to "do something different" next year, so, after four years of fun, the 'Cat is up for sale. "If we end up with another doublehanded boat, we'll be back," says Siddens.

2) *Roshambo*, F-31, Darren Doud; 3) *Voyager*, Beneteau 345, Steve Hocking. (31 boats)

## BAMA Three Sigma — F-27



### Christopher Harvey BAMA

"My throwout was better than his," laughs Chris Harvey (center) of his first BAMA Cup win. The 'his' in this case refers to 2006 season champion Ross Stein on *Origami*. And the throwout situation went something like this:

The BAMA fleet races a diverse 10-race, three-throwout series consisting of three shorthanded events, two pursuit races, two ocean races, three interclubs — "and at least four good parties." Going into the last event, Richmond YC's Great Pumpkin Regatta in October, Harvey and Stein were tied for first place. Whoever won the Pumpkin would win the season. However, unlike most fleets who use the Great Pumpkin's 'serious' Saturday buoy races as season counters, the BAMA guys score only Sunday's pursuit race. When that was cancelled due to no wind, it became a 'forced' throwout — meaning everyone had to 'take back' a race they had planned to throw out and, as Chris says, his was better than Stein's.

Chris's crew for '07 was Philip Jenkins and Scott Lemming. "I know everybody says it, but these guys are the reason we won. They're really good."

Chris's best race was the Second Half Opener — they rounded the weather mark right behind an SC 52, and at the finish line, the only boats in front were other 52s and Melges 24s. The worst moment was the Vallejo Race, where *Three Sigma* was five minutes late to the start and finished third in division . . . by five minutes.

2) *Origami*, Corsair F-24, Ross Stein; 3) *Wingit*, F-27, Ray Wells. (8 boats)

## Wylie Wabbit Mr. McGregor



### Kim Desenberg Richmond YC

Old age and treachery are hard enough to beat, but when you realize that Kim Desenberg *built* all 63 Wylie Wabbits back in the 1980s, doesn't his 2007 win seem somehow, well . . . illegal?

We're kidding, of course. Desenberg, who now works at KKMI boatyard, is one of the super good guys of the sport, and he had to work hard for every victory in this friendly-but-competitive fleet. Plus he's quick to defer any personal accolades to his crew John Groen and Terry White — as well as to the great conditions this year, great competitors in some races (and the absence of some of them in others) — even designer Tom Wylie for designing "a pretty neat little boat."

One of the things that keeps this fleet so sharp is that many members sail regularly on other boats. For example, Tim Russell (*Weckless*) won the J/105 season this year. Bill and Melinda Erkelens (*Jack*) took third in the Moore 24 season. Desenberg himself races a Flying Scot in Inverness and won the Hog Island Race with Colin and Hilary Moore of *Kwazy* as his crew.

All of which is not to say the Wabbit fleet is hurting. A dozen boats hit the line regularly, and the fleet got two or three new members this past year.

As for that age thing, "I did turn 60 this year and don't know how much longer I can hold off the younger set," says Desenberg — "But Jim Malloy is still the oldest one in the fleet!"

2) *Weckless*, Tim Russell/Rusty Canada; 3) *Kwazy*, Colin Moore. (12 boats)



# SEASON CHAMPIONS, PART III

## Sr. Solo Dinghy El Toro



### Gordie Nash Richmond YC

Gordie Nash cut his sailing teeth about the same time as his real teeth. The son of sailmaker and Bay Racing grand dame Jocelyn Nash, Gordie went sailing long before he could walk, and by age 5 was helming El Toros out of RYC's Junior Program. He quickly ascended the ranks into big boats, but dropped out of sailing when IOR caught on, switching to competitive rowing. "By the time I blew out my elbows, IOR was on the way out so I started sailing again," says the affable Sausalito boatbuilder. He gravitated back to the Toros in 1990.

"These boats are easy to learn but hard to master," he responds when asked what keeps him coming back. "With a boat this small, you really learn a lot about balance, sail trim, and how to feel the way a boat's going through the water — all great skills that transfer well to bigger boats."

Gordie says a big part of his success in '07 was getting a lot of 'his' conditions this year: long weather legs, 6 to 10 knots of breeze and not many shifts. But with a deep pool of talent in the fleet, nothing's ever 'for sure'. "Throw in shifts, and Art Lange will win. If it's really light — or really heavy — Fred Paxton just walks away from the fleet," says Nash.

When he's not sailing the 'Toro, Gordie can be found sailing his big boat, the radically customized Santana 27 *Arcadia*. How does he balance the two campaigns? "As president of the El Toro Fleet, I can schedule things. So far, there haven't been many conflicts."

2) Fred Paxton; 3) Art Lange. (32 boats; [www.eltoroyra.com](http://www.eltoroyra.com))

## Jr. Solo Dinghy El Toro



### Patrick Tara San Francisco YC

Patrick, an 8th grader at Pacific Collegiate School in Santa Cruz, started sailing El Toros around age 5 with his father, Paul. "All I remember about the first time was being in the bottom of the boat crying that we were going to get run over by fishing boats," he laughs. He's come a long way since then, beginning serious racing in the Jr. El Toro circuit in '04 and having his first 'big' win at the 2006 Junior North Americans — where his father also won the senior division. But Patrick admits that victory was a hollow one since he was the only Junior that showed up that year. So he came back this year and won the three-race NAs with straight bullets — this time against 35 boats. He also won the season overall in the Junior Toro fleet.

Much of Patrick's sailing education came from just hanging around the extended Toro family. Before he started racing, he'd travel to regattas with Dad and, while Paul was sailing, Patrick hung out on the crash boat and just soaked it all in. Or at weekend regattas like Clear Lake, he'd sit around the campfire at night and listen to Fred Paxton or Gordie Nash or Dave Vickland talk about sailing and the old days when there were so many boats that you could "walk across the lake without getting your feet wet."

All of which made the finish of the last race of the NAs the most memorable moment of the summer for Patrick — as he crossed the finish line, Paxton gave him an extra-long toot on the horn for a job well done.

2) Mackenzie Cook; 3) Marina Fennell. (32 boats; [www.eltoroyra.com](http://www.eltoroyra.com))

## Two-Person Dinghy Vanguard 15



### Nick Adamson Treasure Island SC

2007 was a good year for Nick Adamson (right) and crew Jago Macleod. Particularly the V-15 Nationals sailed out of the StFYC in August. Going into the last race, the duo's #891 was in second — but a full 12 points behind leaders Rich Feeny and Jen Hoyle. Nick and Jago got a decent start and finished third, hoping at best to retain second overall. But Feeny and Hoyle were learning the harsh realities of mistakes in a fleet as competitive as this one. They had a bad start and things went south from there. When the trophies were announced, Adamson and Macleod were blown away to learn *they* had won — by one point!

That's pretty much how the rest of the season went for 891, as well. Lots of great competition, lots of hard-won victories — and their own share of less-than-stellar performances. Fortunately, the V-15 schedule lists about 45 races, of which 23 are scored. So the more you do, the more 'throwouts' you can take — and the better your score. (Adamson and Macleod attended about 3/4 of the events.)

Nick, a property manager, is no stranger to dinghies or tough competition. One of the original founders of the local V-15 fleet back in 1998, his resume also includes the 1996 Olympics in Lasers (he finished mid-fleet).

A dozen boats competed for the V-15 season title. But an even bigger fleet, about 20 boats, did their Thursday Night series. Ken Turnbull and crew Rebecca Beard won that 'half' of the season.

2) Kevin Richards; 3) Ken Turnbull. (49 boats, 6 qualified)



Come visit DeWitt Gallery & Framing in Downtown Pt. Richmond.

**DeWitt**

**BIG SALE**  
**January 8-31**

- DeWitt Giclee' Prints
- Custom DeWitt T-shirts
- Custom DeWitt Apparel
- Frames • Posters

**DeWitt Art Gallery & Framing**

121 Park Place, Point Richmond, CA 94801

**(510) 236-1401 • (800) 758-4291**    [www.jimdewitt.com](http://www.jimdewitt.com)

Tuesday-Thursday 10:00 a.m. to 5:00 p.m. • Friday 10:00 a.m. to 3:00 p.m. • Saturday Noon to 5:00 p.m.



# MAX EBB

"Cancelled?" my foredeck crew gasped in horror. "What do they mean, cancelled?"

"We want to race," moaned my assistant trimmer, new to the game.

"The wind's only 20," chimed in our tactician. "What's their problem?"

"Wimps!" cried a nearby older sailor who was dressed more for a formal dinner than for battling the elements. "Back in the day, it was up to the skipper to decide whether to race or to retire. I'll tell you, some of my best races were sailed under gale warnings."

They weren't fooling anyone. It was a miserable day for sailing, and everyone, my crew included, was secretly delighted that the race committee had the good sense to call off racing for the day.

"I'm disappointed too," I lied. "We haven't seen wind like this since summer, and here I am with my heavy crew all suited up and looking forward to it."

My crew nodded in solemn agreement. Liars, every one of them.

"So what are we going to do now?" whined my foredeck crew as another blast of wind and rain rattled the big plate glass window overlooking the harbor. We all moved a few inches farther away from the glass. "Can't we go out sailing anyway, just for practice? Besides, you have to get the boat home somehow."

Tempting as it was to call his bluff, a soft chair in front of a fireplace seemed like the better call.

"No, the boat's fine where it is at the guest dock," I said. "We'll do the winter beer can race next Saturday, since we're on this side of the Bay."

"Well, okay then," the crew grumbled. He could have won an Oscar, the way he pretended to be heartbroken. "But I still think they should leave the decision to us, just like it says in the rule book."

Relieved as I was to not have to race in stormy conditions, I did feel bad that my crew had dutifully shown up for a cancelled race. So I did the only honorable thing:

"Let's have lunch," I announced. "This club has really good restaurant service. On me."

We weren't the first crew to have that idea, and the yacht club's restaurant was at capacity.

"Do you mind sharing a table?" asked the hostess as she handed us menus

and, without waiting for an answer, led us to a table at which two people were already seated. One was the older sailor who, just a few minutes previously, had called the Race Committee wimps.

But our count was off. Lee Helm, although she was crewing on another boat for this series, always has her radar set for a free meal. And the more expensive it is, the higher her receiver's sensitivity. She had somehow materialized at exactly the right time.

After pulling over one more chair and squeezing in a little, we all had warm, dry and comfortable seats with a great view of the storm outside.

"Max, your yacht club should totally have restaurant service, too," Lee suggested.

"Look, they even put a picture of the Commodore's boat on the menu," said our new crew.

"We could at least do the fancy menus for our barbecues," I said. "It's a great picture."

"Thank you!" said the older sailor sitting across from me, who introduced himself as the club's Commodore.

"Nice looking boat," I said. "Didn't you used to race YRA? We haven't seen the boat out there for the last few years."

"Oh yes, I used to race almost every weekend, bashing around the Bay," he recalled. "But now I just do the midwinters, the Friday nights, and some of the special regattas. Better competition, more interesting courses, better parties. You know the drill."

"Better competition on Friday nights?" I questioned. "The YRA fleet would love to have you back in the HDA division."

"Yes, sometimes our Friday night races are quite a bit tougher than what's left in the YRA handicap divisions," he asserted.

"He's right," agreed my tactician. "In some of the classes, it's getting so that all you have to do is show up for every race to win a season championship. Kinda takes the fun out of it."

"But YRA entries are almost holding steady," added the Commodore's dining companion, who turned out to be the club's Race Committee Chair.

"The long-term trend is pretty bad," said Lee.

"Especially if you look at actual race

*Everyone was secretly delighted the race was called off.*



participation instead of entries," added the tactician.

"YRA isn't circling the drain yet," said Lee, "but it will be in a few years at the rate it's going."

"On the other hand," countered the Commodore, "if you count everything outside the YRA format, sailboat racing is booming here on the Bay."

"For sure," said Lee. "Like you say, it's the weekend club regattas, beer can races, midwinters, ocean races, Big Boat Series and other wacky special events that have all the market share."

"So where do you think YRA should go from here?" I asked. "Do we even need it?"

"We sure do," the tactician answered quickly. "It serves a number of critical functions: Permanent racing marks. Appeals Committee, liaison with the Coast Guard for regatta permits, support for entry-level racers and so on. We don't want YRA to go away."

# — CAN'T HIDE THOSE LYIN' EYES



***Making the YRA a membership-based organization, and reshuffling the fleets, could potentially reenergize Bay racing, offering more opportunities for more sailors.***

"Of course not," said the Commodore, "but YRA has to change with the market. For too long, they've been trying to turn back the clock to the '60s and '70s when we had large fleets of production cruiser-racers that made up the bulk of the YRA divisions. The boats being sold today are different, with the fleets polarized more into cruisers that aren't set up to race, and single-purpose racers that are hard to cruise. We just don't have the numbers interested in the YRA style of weekly Bay racing. I hate to say it, but I think YRA is at the end of a 40-year experiment."

"What was the experiment?" I asked.

"Consolidating regatta race instructions into a consistent series, and taking de facto sponsorship away from the clubs," he answered. "But without those affordable cruiser-racers being sold in

large numbers, the YRA paradigm has become less viable."

"No, it's not just the kinds of boats," said the Race Committee Chair. "The racers are aging too. All the kids are windsurfing or kiteboarding."

"So what's YRA supposed to do about it?" asked my novice crew.

"Here's my plan," said the RC Chair. "For the last few decades, YRA associations have been organized around boat types — one-design, handicap, woodies, multihulls. There was always some tension within each group as to the types of courses and schedule they wanted: One race per day versus two, long or short courses, Central Bay only, North or South Bay included in the season or not, Vallejo counts or doesn't count, and so on. So for most of the entrants, the YRA season is a compromise. Add that to what happens as YRA participation

shrinks. We have an RC out there all day for just 20 boats in the handicap association, with only a couple of boats in some of the starts. Then another club runs almost exactly the same thing for one-designs."

"I think I see what you're getting at," said my foredeck crew. "But if you try to combine the race management resources, even fewer racers would get the courses and schedules they want."

"Unless," said the RC Chair, "we reshuffle the fleets by the sort of races they want instead of by the type of boat or type of handicapping."

"You mean, do away with the Charter Associations?" I asked. "That will be a tough sell. The association level is where the racers have some say in how the races are run."

"The associations would still be in control, but the membership would reshuffle. For example, fleets that wanted all two-race or three-race days on the Cityfront or Knox courses would be in one association. Probably woodies and some of the more high-pressure one-designs. Fleets that wanted only one race per day and longer courses, including North and South Bay, in the schedule would opt for a different association. This would probably include handicap divisions and most of the older one-design classes with small fleets."

"What about the Party Circuit?" I asked, passing the wine list to my tactician so he could make the right call.

"That's the only thing that kept YRA alive last season," said the Commodore. "Party Circuit seems to appeal to all those new cruisers with no racing sails and rough bottoms. I think it's because the long point-to-point races throw in so much luck, good or bad, that a slow boat sometimes comes out on top. Or at least they have the illusion that they can come out on top if they get lucky."

"The Party Circuit fleet would fall into the new 'Destination Race' category," explained the RC Chair. "We could put together a great season for them, including Vallejo, the Point Bonita part of the second half opener, maybe a weekend to Coyote Point and back, maybe Jazz Cup if we can talk them into making it a YRA event, or Martinez or Antioch if we can't. The multihulls would probably go for the Destination Race schedule also, at least the ones I've talked to."

"Singlehanders would fit into that destination category, too," I suggested.

"What happens to the ocean racers?" asked the foredeck.

"No change there," said the RC. "They're already properly segregated



# MAX EBB

from the rest of YRA."

Lee was uncharacteristically quiet through this discussion, speaking up only to order the lobster bisque and the poached salmon when orders were taken. That's when I noticed she was scrawling something with a heavy black marker on the back of the menu, blotting out most of the printing.

"Lee, what are you working on?" I finally asked.

"It's, like, almost done," she said as she drew a few more lines and arrows as we waited for an explanation. "Finis!" she finally announced. "The new YRA."

Lee had produced a chart showing exactly how the YRA associations could be reorganized.

"I call them YRA-1, YRA-2 and YRA-3 for the three different styles of closed-course Bay racing. Then there's the Destination Race series for Party Circuit, multis and shorthanders, and the Ocean Series left as is."

"Yes, that's about how I imagine it would look," said the RC Chair.

"I also have a list of the various types of boats that would likely opt in to each of the race formats," she explained.

"With circles and arrows and a paragraph on the back of each one explaining what each one is," joked the Commodore,

*"YRA needs to become a membership organization, like US Sailing."*

but the '60s music reference was lost on Lee.

"I think this could work," added the RC, "because it allows the Charter Association to stay pretty much intact. No political skin off anyone's back to reorganize the racing around this system."

"Well, it's nice in theory," pronounced the Commodore. "But I have a completely different plan."

"Your reorganization plan still assumes that people will continue signing up for the YRA seasons," said the Commodore. "The market trend is in the other direction, and I'm not convinced this would reverse the trend, even if more of that silent majority of cruisers do go for the Party Circuit. It won't be enough. And the problem with the Jazz Cup is typical. Why should a club that already runs a popular event give up its entry fees?"

"So, is this a fallback plan for when YRA goes under?" asked my tactician.

"It's a major transformation," he said. "What I think YRA needs to do is become a membership organization, more like US Sailing. Anyone who races on the Bay should be a member. But instead of trying to beat the dying horse of YRA season participation, let's concentrate on YRA's more general roles and stop worrying about it. YRA could get out of the business of writing sailing instructions, taking entries, and scoring races."

"What's left? And why would anyone join?"

## SCHOONMAKER POINT MARINA

• IN SAUSALITO •



Call the Marina Office  
for more information

**415•331•5550**

**FAX 415•331•8523**

or check our web site at  
[www.schoonmakermarina.com](http://www.schoonmakermarina.com)

85 LIBERTY SHIP WAY, #205  
SAUSALITO, CA 94965



"Sausalito's finest Marina"

**160 Berth Marina in one of the most beautiful spots on the Bay**

- Visitor berths • Guest moorage able to handle yachts up to 200 ft.
- Dry storage • Waterfront Offices • Three-ton Hoist • Windsurfing
- Deli • Beach • Rowing • Kayaking • Yacht clubs always welcome

# — CAN'T HIDE THOSE LYIN' EYES

"People would join to support the functions that benefit everyone: Racing marks, PHRF Committee, Appeals Committee, Coast Guard relations and schedule coordination."

"It's going to be a tough sell," I said, "if a YRA membership doesn't include any race entries."

"Yes, but YRA's costs go way down as well. We need a hook, like tying YRA membership to the PHRF certificate. US Sailing did something like that several years back with that insurance deal and the entry discount, and it worked great. If we can get local sailors to think that it's more important to be members of YRA than US Sailing . . ."

"They tried that PHRF-YRA linkage a

few years ago," my tactician reminded him. "Didn't work at all. I was running

get a \$35 certificate when it only took five seconds for the office to write '134' at the bottom of the form."

"The other problem," said the RC Chair, "is that PHRF is a committee of HDA, and YRA has no direct control."

"That is a sticking point," admitted the Commodore. "But there are solutions to both problems."

"For sure," Lee interrupted. "The PHRF fee structure should be, like, two-tier. I mean, that Santana 22 should only have to pay \$5 for processing a known one-design rating, but like, a one-off Rub-a-dub 32 should pay \$75 for a rating that makes

the PHRF Committee sit around eating pizza for an hour figuring out what to do with them."

"My numbers were \$10 and \$100,"

## YRA CHARTER ASSOCIATIONS BY RACE TYPE

YRA-1 (HDA)	YRA-2 (ODCA)	YRA-3 (Woodies)	PCYRA (Party Circuit)	OYRA (OYRA)
• Buoy races	• Buoy races	• Buoy races	• Point-to-point courses	• Ocean courses
• Long courses	• Shorter courses	• Shorter courses	• Parties	• Full season
• Main Bay+*	• Main Bay+*	• City, Knox, Circle	• Short season	
• 1 race/day	• 2 races/day	• 2-3 races/day		
• Full season	• Full season	• Full season+		

## LIKELY PREFERENCES FOR BOAT TYPES

- One-design: YRA-1, YRA-2, YRA-3, PCYRA, OYRA
- PHRF: YRA-1, YRA-2, PCYRA, OYRA
- Woodies: YRA-3
- Multihulls: PCYRA, OYRA
- Measurement Classes (IOR, IRC, IMS, etc.): YRA-1, PCYRA, OYRA
- Singlehanders: PCYRA, OYRA

\* City, Knox, Circle, Southampton, T.I. and possibly one North & South Bay per season. Note: "Full season" is 10-12 race days, "Full season+" is 14-20 race days.

my club's beer can series at the time, and I could not, in good conscience, make some poor guy with a Santana 22 who wanted to try out racing for the first time

# MARITIME INSTITUTE



## Commitment

**Offer the best and most practical instruction for mariners!**

We assist our students at every step to see that, not only are they prepared to pass the USCG test, but, more importantly that they're more likely to retain and use what we've covered. A well prepared mariner will be a safer mariner.

Some schools are offering a barebones course to get a student through the exam; a number of students won't pass the test and there won't be anyone there to tutor them to understand and to retest and pass what was missed. Even though 98% of our students pass the exam on their first try, as a matter of principle, we provide the additional where it's needed and at no additional cost.

For over 30 years we have built a reputation for offering the very best mariner's instruction available, anywhere. Give us a try and find out why.

**CALL TOLL FREE 888-262-8020**

Visit our website for more information.

[www.MaritimeInstitute.com](http://www.MaritimeInstitute.com)

**CAPTAIN'S LICENSE • RADAR • RADIO • NAVIGATION • SAFETY**





# MAX EBB

said the Commodore, "but you've got the idea."

"Do you really think you can make people pay \$100 for a PHRF certificate?" I asked.

"If they have a one-of-a-kind, what other option do they have?" he responded. "The club race committees have no other way to rate if they can't look up a sistership. If they can look up a sistership, then the rating doesn't need committee action, and it should be issued at the cheap rate."

"Tell me again how this is going to make people sign up for YRA, when there are no YRA races to enter?" asked my new crew.

"YRA membership will be inexpensive, and it will be part of a PHRF certificate. Or rather, YRA membership will be required to get a PHRF rating."

"HDA will never go for it," said my foredeck crew. "And PHRF is a committee of HDA."

"That's the evil part of my plan," whispered the Commodore. "The way entries are shrinking, there won't be an HDA in a few years. Control of PHRF defaults to

YRA, which is where it should be, and then we can tie YRA membership to it. As long as membership is inexpensive, I think we can pull it off. But to keep it inexpensive we have to pull way back on

*"Why do you think Vallejo is still going strong after 107 years?"*

actual race management functions. Let the YRA members choose their own mix of races to sail every year, and get YRA out of the race management business."

I was about to say something but he cut me off.

"I know, races are officially sponsored by clubs, not by YRA, but in practice it's YRA's show, with the big clubs sending their second-string volunteers."

Since I had helped run a YRA race or two myself last season I wasn't sure if I agreed that most clubs send their "sec-

ond string" RC people to do that job. But the conversation moved elsewhere.

"Would your proposal mean, like, no more YRA season champs?" asked Lee.

"I agree with Lee," added my foredeck crew. "What's the point, if you can't get your mug in the rogue's gallery at the end of the season?"

"Fleets would still be free to define a YRA season by picking and choosing from the various club events. Some of the one-design fleets already do that. YRA could still award trophies. The difference is that racers would have to enter the events that comprise their series on their own."

**F**ood arrived, and that kept everyone quiet for a while.

"That would solve the problem of getting Jazz Cup included in the Party Circuit," remarked the foredeck crew through a mouthful of rare steak. "And



# VALLEJO MARINA

## Gateway to the Bay & Delta



*Join us!  
We love making new friends  
and spoiling them!*

- **Competitive Rates!**
- **Ample Guest Dock**
- **Full Service Boat Yard and Chandlery**
- **2 Restaurants for Breakfast, Lunch, Cocktails and Dinner**
- **Covered and Open Berths**

**48-ft.  
BERTHS  
NOW  
AVAILABLE**

**Winter Berthing  
~ Close to Home ~**

- **One hour from Sacramento**
- **Only Three hours from Reno**
- **Easy access to San Francisco Bay and the Delta**

**(707)  
648-4370**

Fax 707-648-4660

**42 Harbor Way  
Vallejo, CA 94590**

[www.ci.vallejo.ca.us](http://www.ci.vallejo.ca.us)



# — CAN'T HIDE THOSE LYIN' EYES

Vallejo YC would finally be able to collect entry fees to pay for those flags," added the Commodore.

"But it would end up costing us all a lot more in entry fees, when you add it all up."

"Still much less than a new sail or a bottom job," Lee pointed out as she sipped her lobster bisque. "It costs money to put on good events, and I think it's better when racers, like, pay directly for good race management instead of having to put up with advertising and races being distorted in ways that please the sponsors instead of the sailors."

"Well, your plan might be where we end up in the long run," said the Race Committee Chair, "but YRA isn't in that much danger of going under with the basic structure it has now. Party Circuit is what will keep it afloat, I think, as long as they stick to the destination race

format. That's the best example of following the market instead of trying to sell something that people aren't buying."

"Except that they're totally doing it wrong for next season," said Lee.

"How so?" I asked.

"The end-of-season weekend race is, like, back to the same old YRA format. I mean, look how few boats showed up for the second day of Second Half Opener last year. Get a clue, guys! The Party fleet wants point-to-point races, not round the buoys. Why do you think Vallejo is still going strong after 107 years?"

"We did try to get Jazz Cup in the party circuit," said the Commodore.

"Here's how to fix that end-of-season event," said Lee, now well into her salmon. "Start the first race of the weekend down by the Estuary. Maybe even off the south shore of Alameda. The first race finishes off Corinthian, and the second race is a normal buoy race. Then on Sunday, the last race finishes over at Berkeley or Richmond, or back down in the South Bay."

"It would make the crews much more likely to stay on their boats that night," noted the foredeck crew. "and that's what really makes a good post-race party."

"It's not too late!" Lee warned. "You can still turn that end-of-season weekend into a destination race, save the season for the Party Circuit, and save YRA as we know it."

"Interesting concept, and it might work," said the RC Chair. "I'll bring it up at the next meeting."

"Just don't make us all pay separate fees for each event on the YRA schedule," I said. "Campaigning a race boat is already expensive enough as it is."

"But entry fees are such a small part of the cost of racing," said my tactician, "Think of it as a market adjustment."

I was all set to argue that YRA race fees were already too high and that this was one of the reasons that entries were declining. But then a small tray holding the bill for our lunch was placed on the table in front of me.

It was more than my YRA entry fee for the season.

— max ebb

The North Bay's complete marine service facility:

- Complete chandlery
- 40-ton haulout service
- Engine & drive service
- Trailer boat/outdrive service & repair
- Bottom paint
- Finish paint
- Fiberglass repair
- Marine electrical



## Don't Pass Us By...

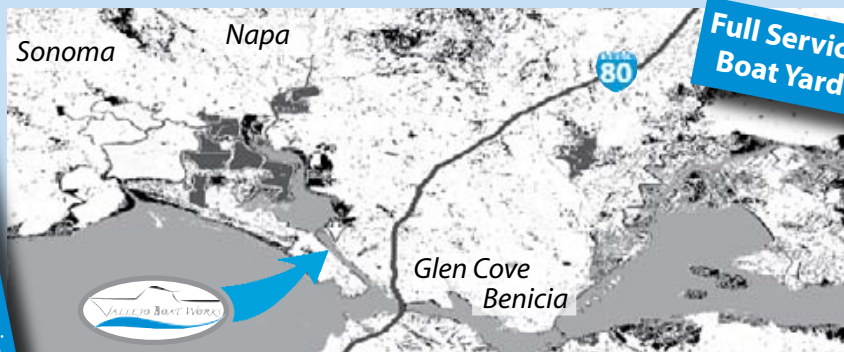

Factory  
Authorized  
Dealer

"If it's broken,  
we fix it."

Onan

AWLGRIP

Attention !!!  
Herring Boat  
Fishermen:  
I will match \$\$  
on long-term  
storage fees!  
Limited Space Available.  
First Come, First Served.

Why Haul Your Boat Down to the Central Bay?

[www.vallejoboatworks.com](http://www.vallejoboatworks.com)

1 Harbor Way, Vallejo  
(adjacent to the Vallejo Marina)

(707) 554-2813



# THE RACING

Happy 2008! In this first Racing Sheet of the new year, we report on a win of the warm, sunny **Key Largo Regatta** by some sailors from the cold, rainy Bay; check out what's going on at GGYC's **Manny Fagundes Seaweed Soup Regatta** (and list box scores for all the other Midwinters we could find), introduce you to an inspiring woman with a great idea for a new regatta, take you back to those thrilling days of yesteryear — and tomorrow — with a look back and forward at **Ragtime** and the reborn **Tahiti Race**, go Down Under for a report on **Rosebud's** win of the **Rolex Trophy**, and finish off with a mess of **race notes** from far and wide.

## SF Boat Wins Inaugural Key Largo Event

Tom Kassberg is a sailor who likes competition. When the former owner of the J/105 *Walloping Swede* started looking around for a new ride, he wanted something a bit easier on the wallet, but just as competitive: *voila* — the Melges 24! Seadon Wijsen just happened to have the battle-tested #525 up for sale and the deal was done. And you want competition? — Kassberg's first formal race in the boat was last summer's Fullpower Melges 24 Worlds, sailing against the likes of Shark and Philippe Kahn, Brian Porter and eventual winner Dave Ullman. *Flygfisk* — 'flying fish' in Swedish — finished about midway down the 58-boat roster, and Kassberg was if anything even more fired up than before.

Fast forward to sunny, warm Florida last month, when Kassberg and his Bay Area crew, Guy Rittger, Andrew Whittome and Matt Siddens wowed the locals with a surprise win at the first-ever Key

part in the seven-race, one-throwout regatta, with Tampa's George Haynie leading after the first day's 15-knot conditions. With Sunday winds up a bit and gusting into the mid-20s, *Flygfisk* reveled in the more Bay-like (but lots warmer) conditions, coming back from an over-early in the last race to take second, but two points ahead of Haynie to take the overall win.

"We entered mainly to tune the boat up for Key West," says Kassberg, a biotech engineer. "But it was sure a nice surprise to win it." He doesn't expect to show quite as well when the 'big dogs' of the fleet gather again at Acura Key West Race Week January 21-25. But he says he'll have fun just the same.

In fact, Kassberg has liked the whole southern experience so much that he's contemplating racing on both coasts next year. He'd leave *Flygfisk* on the Eastern seaboard, trailering the boat to events like the Melges 24 Nationals in Charleston, and the NAs in Annapolis.

At the same time, he hopes to charter a local boat to sail with the San Francisco fleet. Sounds like the best of both worlds to us.

1) **Flygfisk**, Tom Kassberg, San Francisco, 9 points; 2) **Firewater**, George Haynie, Tampa, 11; 3) **Cre83**, Cary Siegler, Miami. 20. (9 boats)

## Berkeley YC Midwinters

"I still can't believe how mild and gentle the whole weekend was," says Race Chair Bobbi Tosse of BYC's first Midwinter Race weekend on December 8-9. "It was even almost warm."

Seventy-eight of 95 sign-ups showed up Saturday on the Berkeley Circle to



sail the 8-mile double windward-leeward course — which, as the day wore on and the breeze turned to zephyrs, was apparently a tad too long. When the zephyrs turned to about 3 knot 'breaths', the RC scooted down to the leeward mark and ended the race to finish everyone before it died completely.

Sunday saw 29 of 42 entries arrive for some fun. And again, despite a forecast for 20 with gusts to 30 from the north — a gentle southerly ushered in the starts. It promptly shifted west after that, allowing most boats to easily lay the weather mark in one tack.

"No crashes, no injuries, no broken boats," reports Tosse. "Just lovely sailing — as long as you weren't in much of a hurry."

### SATURDAY

DIVISION A — 1) **Bodacious**, Farr 40 1-ton, John Clauser; 2) **Sleeping Dragon**, Hobie 33, Dean Daniels; 3) **Relentless**, Sydney 32, Arnold Zippel. (9 boats)

DIVISION B — 1) **Backatcha Bandit**, Thompson 650, Ben Landon; 2) (no name), Ultimate 24, Peter Cook; 3) **Baleineau**, Olson 34, Charles Brochard. (7 boats)



CRIS SANDIFER

'Flygfisk' crew (l to r) Andrew Whittome, Tom Kassberg, Guy Rittger and Matt Siddens. Next stop, Key West!

Largo Regatta, sailed out of the Upper Keys Sailing Club December 8-9.

Nine boats, most from Florida, took



Above, Kassberg's Commandos race the azure waters off Key Largo. Right, chuting the breeze at the almost-as-balmy (not!) Berkeley Midwinters.

DIVISION C (PHRF 120-168) — 1) **Chesapeake**, Merit 25, Jim Fair; 2) **1st Impression**, SC27, Rick Gio; 3) **Andiamo**, SC27, Pancho Blanco. (5 boats)

DIVISION D (PHRF >171) — 1) **Can O' Whoopass**, Cal 20, Richard Van Ehrenkrook; 2) **Ypso**, Cal 2-27, Tim Stapleton; 3) **Tappo Piccolo**, Cal 20 (modified), David Bacci. (6 boats)

EXPRESS 27 — 1) **Motorcycle Irene**, Will Paxton; 2) **Moxie**, Jason Crowson; 3) **Xena**, Mark Lowry. (13 boats)

J/24 — 1) **Phantom**, John Gulliford; 2) **Frogflips**, Richard Stockdale; 3) **TMC Racing**, Michael Whitfield. (5 boats)

MOORE 24 — 1) **Gruntled**, Simon Winer; 2) **Blister**, Matt Johnson; 3) **Topper II**, Conrad Holbrook. (6 boats)

NEWPORT 30 — 1) **Achates**, Robert Schock; 2) **Harry**, Dick Aronoff. (2 boats)

OLSON 25 — 1) **Synchronicity**, Steve Smith; 2) **Shadowfax**, Mark Simpson; 3) **Samba**, Bob Gardiner. (8 boats)

OLSON 30 — 1) **Hoot**, Andy Macfie; 2) **Naked Lady**, Jeff Blowers; 3) **Voodoo Child**, Charles Barry. (10 boats)

ULTIMATE 20 — 1) **Babe**, Phil Kanegsberg;

2) **UFO**, Trent Watkins; 3) **Layla**, Tom Burden. (4 boats)

#### SUNDAY

DIVISION A (PHRF 0-99) — 1) **Hoot**, Olson 30, Andy Macfie; 2) **Wraith**, Olson 30, Ray Wilson; 3) (no name), Ultimate 24, Peter Cook. (6 boats)

DIVISION B (PHRF 102-144) — 1) **1st Impres-**

spewed oil all over the place, and both racing and recreational sailing all over the Bay screeched to an abrupt halt for two weeks. . .

But that was then. As if someone had thrown a celestial switch, the segue from November to December could not

CRIS SANDIFER

### Manuel Fagundes Seaweed Soup Regatta

Oh the irony of it all. Golden Gate YC's 37th Annual Manuel Fagundes Seaweed Soup Regatta series was supposed to get underway on November 3. But there was no wind so it was cancelled. The following week, a freighter ran into the Bay Bridge and







have been more dramatic. On December 1, the breeze was back, the water pronounced clean, the skies sunny — and the 68 boats in 8 divisions were ready to finally kick off GGYC's midwinter series. Winds in the 10-12 knot range ushered the fleet around a flat central Bay.

Among the better performances of the

**Scenes from the 'Seaweed (clockwise from above) — 'Mr. Magoo' on the run; Santa in training for the big sleigh ride; 'Bessie Jay' crew on high alert; (inset), 'Shaman' on the way to a Division win.**

day, ICs kicked some tail in the PHRF 5 Division, with *Youngster*, *La Paloma* and *Whitecap* taking first through third in that order. Include the Thunderbird *Crazy Jane* in fourth and let's hear it for

the classics, which beat out an eclectic group of Santana 22s, Catalina 30s and a J/24 or two.

The remaining Seaweed Soup Regattas are scheduled for January 5, Febru-





ALL PHOTOS WWW.LYONSIMAGING.COM

ary 2, and March 1.

DIVISION 1 (PHRF <45) — 1) **Alpha Puppy**, 1D35, Mark Witty; 2) **Howl**, Sydney 38, Peter Krueger; 3) **Summer Moon**, Synergy 1000, Joshua Grass. (10 boats)

DIVISION 2 (PHRF 46-69) — 1) **Mr. Magoo**, J/120, Steve Madeira; 2) **Q**, Schumacher 40, Glenn Isaacson; 3) **Quiver**, N/M 36, Jeff McCord. (9 boats)

DIVISION 3 (PHRF 70-110) — 1) **Jam Jam**, Melges 24, Neil Ruxton; 2) **Yucca**, 8-Meter, Hank Easom; 3) **Tivoli**, Beneteau First 42S7, Torben Bentsen. (11 boats)

DIVISION 4 (PHRF 111-136) — 1) **Shaman**, Cal 40, Steven Waterloo; 2) **Arcadia**, Santana 27, Gordie Nash; 3) **Lazy Lightning**, Tartan 10, Tim McDonald. (7 boats)

DIVISION 5 (PHRF >137) — 1) **Youngster**,

IOD, Ron Young; 2) **La Paloma**, IOD, James Hennefer; 3) **Whitecap**, IOD, Henry Hernandez. (11 boats)

CATALINA 34 — 1) **Crew's Nest**, Ray Irvine; 2) **Wind Dragon**, Dave Davis; 3) **Obsession**, Lee Perry. (9 boats)

KNARR — 1) **134**, J. Eric Gray; 2) **Narcissus**, John Jenkins; 3) **Benino**, Mark Dahm. (6 boats)

FOLKBOAT — 1) **Windansea**, Don Wilson;



# THE RACING



2) *Thea*, Chris Herrmann; 3) *Nordic Star*, Richard Keldsen. (5 boats)

## New Regatta Set for June 28-29

Excuse our Greek, but 2006 was a hell of a year for Natalie Criou. Among the good: she bought the Express 27 *Elise* and joined the local fleet. Among the bad, a boat she was helping deliver back from Hawaii after the Pacific Cup (Nick Barran's 40-ft *Mureadritta XL*) was rammed and sunk by whales. A couple months later, in September, her OB/GYN called to tell her she had a tumor. It was eventually diagnosed as a rare type of sarcoma. What followed was the nightmare that Natalie — like most of us — had previously only read about: half a year of fear, pain, illness, self doubt and depression.

Natalie has emerged into the light at the end of that long tunnel with her life and her health (although her treatment regimens are not yet over, she is presently back at her career as a project manager at Google).

She is also back sailing, with a new inspiration to 'return the favor' — give something back to the science that saved her and new hope to the many other people, young and old, who suffer from the

***Back in black — Pacific veteran 'Ragtime' will be on the starting line of the reincarnated Tahiti Race this summer.***

more than 50 known types of sarcoma — which are cancers that develop in connective tissues. Sarcomas account for 1% of adult cancers, but 15-20% of childhood cancers, yet currently only 1% of cancer research funds are specifically allocated for sarcoma research.

The two ways she plans to do it both

***Natalie Criou at the helm of 'Elise'. As a cancer survivor, she's also taken the helm of a worthy cause — and a new regatta.***



COURTESY NATALIE CRIOU

revolve around sailing. In the first, she has dedicated her doublehanded Pacific Cup race aboard *Elise* (with Nathan Bossett) to raising awareness of sarcoma. Second and even more ambitious, she is creating a whole new regatta, open to all boats, which is slated for the end of June out of Richmond YC. We wish the 'Sarcoma Cup' had a prettier name, but then again, it's not a pretty disease.

"Getting the idea for a new weekend event was the easy part," says Nat in her half-French, half-British accent. (She grew up sailing dinghies in France and took up racing when she moved to England in her 20s. She has lived in the Bay Area since 2000.) Even putting together the non-profit Beat Sarcoma ([www.beat-sarcoma.org](http://www.beat-sarcoma.org)) was comparatively easy compared to shoehorning a new race into the busy summer schedule. But talks with various agencies including YRA and the Leukemia Society (which runs a series of regattas across the country) were encouraging, and both the Express 27 fleet and Richmond YC were very enthusiastic about the idea.

So get out your pens and 2008 calendars, folks. Dates for the inaugural Sarcoma Cup are June 28-29. The format will be three to five buoy races on Saturday, a party Saturday night,



RICH ROBERTS

and a pursuit race on Sunday. Natalie says RYC really took the ball and ran with it, among other things assigning PRO Fred Paxton to run the show.

The event is open to all one design and handicap boats. Natalie has already contacted a number of them and

several have made at least verbal commitments.

So let's see: a great weekend of racing (and partying) out of one of the nicest clubs in the Bay Area, at the nicest time of year. There are no major conflicts with other regattas, and all pro-

ceeds will go specifically toward sarcoma research. . . What's not to like?

You will be reading more about the Sarcoma Cup in future issues. Until then, for more on that event, *Elise's Pacific Cup* project, or Natalie herself, go to the [www.beatsarcoma.org](http://www.beatsarcoma.org) website. If you or your fleet are interested in signing up, please contact Natalie at [nat@beatsarcoma.org](mailto:nat@beatsarcoma.org).

### Ragtime Signs Up for Tahiti Race

*Ragtime* is restless, and maybe a little homesick. With a record 14th Transpacific fresh under her wooden hull — trumping the former tie with *Merlin* at 13 apiece — the 65-ft ocean racing icon will return to the South Pacific waters of her birth in the 13th Tahiti Race starting next June from San Pedro.

Owner/skipper Chris Welsh of Newport Beach said the resurrection of the race after a 14-year hiatus was too tempting to pass up.

"For a West Coast sailor, Tahiti is Everest," Welsh said after filing his entry. "I felt it was compelling, like here's the race, you've got the right tool to do it, and who knows how many times in your life you'll have that all at once?"

Other early entries are Doug Baker's Andrews 80 *Magnitude 80*, from Long

## MIDWINTER BOX SCORES

November's oil spill threw a greasy wrench in many yacht club midwinter schedules. Unless they got off a race early in the month, most clubs cancelled all on-the-water activity in November and just began anew in December. Barring another manmade or natural disaster, most of these series will run through March.

### SBYRA WINTER #2 (SPYC, 12/1):

SPINNAKER — 1) **Wired**, Choate 27, Larry Westland; 2) **First Light**, Beneteau First 35S5, Alex Jefferies; 3) **Black Sheep**, Beneteau 25, Ron C. Brown. (6 boats)

NON-SPINNAKER — 1) **Hot Ice**, C&C 110, Mike Haddock; 2) **Columbine**, Islander 44, Dylan Benjamin. (2 boats)

Complete results: [sbyra.home.comcast.net](http://sbyra.home.comcast.net)

### SEQUOIA YC WINTER #2 (12/1):

SPINNAKER — 1) **Made Easy**, Beneteau 42, Jim Peterson; 2) **Yellow Brick Road**, Jeanneau 40, John Draeger; 3) **Magic**, Express 27, Steve Klein. (4 boats)

NON-SPINNAKER — 1) **Iowa**, Hunter 380, Rick Dalton; 2) **Mirth**, Catalina 34, Rick Gilmore.

(2 boats)

Complete results: [www.sequoiayc.org](http://www.sequoiayc.org)

### TINY ROBBINS MIDWINTER #2 (VYC, 12/1):

A FLEET (PHRF 0-174) — 1) **Summer & Smoke**, Ben. First 36.7, Pat Patterson. (1 boat)

B FLEET (PHRF 174+) — 1) **Wings**, Albin 27, Jerry Halterman; 2) **Luna Sea**, Santana 525, Steven Strunk. (2 boats)

C FLEET (NON-SPINNAKER) — 1) **Jasmine**, Ranger 23, George Hale; 2) **Somewhere in Time**, Schock 35, Tom Ochs; 3) **Lita-K III**, Catalina 42, John Karuzas. (3 boats)

Complete results: [www.vyc.org](http://www.vyc.org)

### ALAMEDA / ISLAND ESTUARY #1 (12/9):

SPINNAKER PHRF 0-138 — 1) **Rascal**, Wilderness, Rui Luis; 2) **Ragtime**, J/92, Bob Johnston; 3) **Vitesse**, SC 27, Bart Goodell. (7 boats)

SPINNAKER PHRF 139-189 — 1) **Moore Lights**, Moore 24, Aaron Lee; 2) **Bewitched**, Merit 25, Laraine Salmon; 3) **My Tahoe Too!**, Capri 25, Steve Douglass. (10 boats)

SPINNAKER PHRF 190+ — 1) **Fun Zone**, Santana 22, Tom McIntyre; 2) **Atuna Matata**, Santana 22, Bill King; 3) **Auggie**, Santana 22, Sally Taylor. (3 boats)

NON-SPINNAKER — 1) **Flyer**, Peterson

33, John Diegoli; 2) **Cassiopeia**, Islander 36, Kit Wiegman; 3) **White Cloud**, Yamaha 33, Barbara Jagiello. (4 boats)

COLUMBIA 5.5 — 1) **Alert**, Liem Dao; 2) **Wings**, Mike Jackson; 3) **Krasny**, Zhenya Kirueshkin-Stepanoff. (3 boats)

Complete results: [www.iyc.org](http://www.iyc.org)

### ISLAND FEVER MIDWINTER #2 (SBYC, 12/15):

SPINNAKER PHRF 0-139 — 1) **Savage Beauty**, Flying Tiger, John Lymberg. (1 boat)

SPINNAKER PHRF 140-179 — 1) **Crews Nest**, Catalina 34, Ray Irvine; 2) **Auggie**, Santana 22, Sally Taylor. (2 boats)

SPINNAKER PHRF 180 — 1) **Dancing Bear**, Catalina 30, Joe Askins/Ray Hall; 2) **Huge**, Catalina 30, Amanda Deisher; 3) **Goose**, Catalina 30, Mike Kastrop. (5 boats)

NON-SPINNAKER — 1) **Popeye & I**, Cal 9.2, Ruth Summers; 2) **Seaview**, C&C 115, Pete Hamm. (2 boats)

Complete results: [www.southbeachyc.org](http://www.southbeachyc.org)

### REDWOOD CUP #2 (SeqYC, 12/16):

1) **White Dove**, Beneteau 40.7, Mike Garl; 2) **Magic**, Express 27, Steve Klein; 3) **Made Easy**, Beneteau 42, Jim Peterson. (12 boats)

Complete results: [www.sequoiayc.org](http://www.sequoiayc.org)



# THE RACING

Beach, and Al Hughes' Open 60 *Dogbark*, from Seattle. Another high-end Long Beach boat, Bob Lane's Andrews 63, *Medicine Man*, is verbally committed.

The 3,571-nautical mile race will start Sunday, June 22, at 1 p.m. off Point Fermin in San Pedro, cross the equator and finish at the historic Pointe Venus lighthouse on the north end of the island of Tahiti, six miles east of Papeete.

The race has been run intermittently a dozen times from 1925 to 1994. The record is 14 days, 21 hours, 15 minutes, 26 seconds — an average speed of about 10 knots, modest by current standards — established by Fred Kirschner's Santa Cruz 70 *Kathmandu*, in 1994, the last time the race was run.

Long admired for her sleek, black, low-profile hull, *Ragtime* was built in New Zealand in 1964 by the late John Spencer. Originally christened *Infidel*, the boat was brought to Long Beach in the early '70s, renamed, and in 1973 sailed by a local crew of eight that stunned a skeptical racing community by snatching TransPac's Barn Door prize (first to finish) from the record holder, *Windward Passage*, by 4 minutes 31 seconds — still the closest first-to-finish duel in TransPac history — and followed that with another win in '75.

*Ragtime* has had several owners in her 44 years. One extended her transom 3 1/2 feet (for additional waterline) to a length overall of 65 feet. Welsh took possession three years ago and has added his own touches, including a more powerful rig, a new rudder and — now in process — the fitting of a new, more efficient keel that will reduce displacement by about 1,500 pounds.

The Tahiti Race is open to any 'properly ballasted, self-righting monohull' 33 feet and up with a Southern California PHRF rating no slower than 114. Multi-hulls 45 feet and over are also welcome.

**Meet the new 'Boss': Alex Thomson's newest 'Hugo Boss' was running second in the Barcelona World Race — and gaining fast on the leader as this issue went to press.**

There is no upper size limit. Of course, there are a number of safety regulations and inspections to which all entries are subject. For more on all aspects of the race, log onto [www.transpacificyc.org](http://www.transpacificyc.org).

— rich roberts

## Rosebud Blooms in Rolex Trophy

Roger Sturgeon's TransPac 65 *Rosebud* snuck past local favorite *Yendys* to win IRC Division 0/1 of the Rolex Trophy, an 8-race, 1-throw-out series put on by the Cruising Club of Australia off Sydney Heads in early December.

The Florida-based *Rosebud* — with Santa Cruzan Jack Halterman once again on the helm — was 'fresh off the boat' from San Francisco, where she placed second in class at the Big Boat Series last September.

Racing began off Sydney on December 9. Tied with the R/P 55 *Yendys* through mid-series, Sturgeon's crew leapfrogged ahead in the final four races, ending up with an impressive 1,2,2,1,1,2,2

(11 points) record after throwing out a fifth in the last race, which beat *Yendys* by two points. Thirty-three boats in three one design and three IRC divisions par-

ticipated.

Originally called the British Trophy Regatta, this series of buoy races was conceived as an 'off-year' event for boats in between the Southern Cross Series races (which then included the Sydney-Hobart). Today, the Rolex Cup is a stand-alone event which attracts top boats on its own merits — although most, including *Rosebud*, still hang around to do the Sydney-Hobart on December 26.

## Race Notes

Clash of the Titans — As this issue went to press, two Open 60s screaming across the Southern Ocean 800 miles



ROLEX/CARLO BORLENGHI



ROLEX/DANIEL FORSTER

**Roger Sturgeon's STP-65 'Rosebud' wowed the crowd at the Big Boat Series and recently did the same Down Under. Her next event: the Sydney-Hobart.**

below Australia were practically within spitting distance of one another. They were the Open 60s **Paprec-Virbac 2**, whose co-skippers Jean Pierre Dick and Damian Foxall have led the Barcelona World Race (nonstop doublehanded around the world) since its start on November 11, and British sailors Alex Thomson and Andrew Cape on the big, bad **Hugo Boss**. The latter has been slowly chipping away at the former and after 10,000 miles of racing, at one

point they were only separated by 12 miles. (To see how they're doing when you get this issue, log onto [www.barcelona-world-race.com](http://www.barcelona-world-race.com).) Earlier in the race, **Hugo Boss** set a new 24-hour monohull record of 501 miles. Only five of nine starters are still on the race course, the rest having retired due to damage of one type or another.

Not another one! Not another two! — two new shorthanded round-the-world races were formally announced last month: the **SolOceans Singlehanded** event and the **Portimão Global Ocean Race**. The first is a two-leg affair from France to New Zealand and on around

the globe back to France on 'identical' one design 53-ft boats. The second starts and ends in the title city (which is in Portugal). It has five stops, is being touted as 'affordable' and can be raced either solo or doublehanded. Both events are scheduled to start within weeks of each other next fall. Next up, a special race for left-handed, red-haired guys with blue boats . . . .

Cruel fate — Early in the morning of December 19, just a few hundred miles from the finish line of the **Transat Ecover B to B** race, **Dee Caffari's** Open 60 yacht *Aviva* dismasted in gale conditions. The boat was towed to Spain and Dee, who made history in 2006 by becoming the first woman to sail alone around the world against the prevailing wind and current, has since flown home to England. There was likely still plenty of holiday cheer — her new Open 60 *Aviva* splashed down in New Zealand right before she dismasted the old one. Fifteen boats started the Transat Ecover B to B in Salvador de Bahia, Brazil, on November 29. Twelve toughed it out to the finish line 4,400 miles away in Port-La-Floret, Brittany, with winner **Loick Peyron** on *Gitana 80* arriving on December 14.

In like a Lyon — Congratulations to the Bay Area's **Amy Lyons**, 25, for being named US Sailing's 'US Sailor of the Week' last month. Lyons, who had never set foot on a sailboat until college, has grand goals for her role as program director for Treasure Island Sailing Center, including the expansion of their adaptive sailing program and the launch of a new program aimed at getting Bay Area 4th graders on the water. "It's important to help broaden their horizons about what's out there, within their reach," Lyons said of the kids.

Easy riders — Seven maxi yachts had a smooth ride across The Pond during the first ever **Transatlantic Maxi Yacht Rolex Cup**. Anders Johnson's Swan 70 *Blue Pearl* took top honors. The race, which started November 26, took the 70-ft-or-longer boats from the Canary Islands to St. Maarten in the Caribbean. The International Maxi Association, in cooperation with Italy's Yacht Club Costa Smeralda, dreamed up the 2,700-mile race as a feeder for the winter Caribbean racing circuit. It was such a success that plans are already underway for next year's event.

Mariners with a Mission — At least three Pacific Cup participants are sailing for a cause, and we encourage you



# THE RACING

to help if you can:

- Nathan Bossett and Natalie Criou, aboard their *Expres 27 Elise*, hope to raise awareness and money for the **Beat Sarcoma Fund** at the Stanford Cancer Center. Check out their website at [www.beatsarcoma.org](http://www.beatsarcoma.org) for more on how you can take part; and check out the *Racing Sheet* article on page 170 for more on Natalie and a new fundraising regatta for this worthy cause coming up this summer.

- When Stephane Plihon's son, Evan Luc, was born prematurely, the folks at Children's Hospital of Oakland were so wonderful that he wants to help pay back their kindness by raising funds while crossing the Pacific aboard the Moore 24 *Le Flying Fish*. Plihon and boat partner Jean-Phillipe Sirey, both TransPac and Pac Cup vets, hope to raise \$50,000 with their **Sailors on a Mission** campaign to benefit the Children's Hospital & Research Center Foundation. Find out more at [www.sailorsonamission.org](http://www.sailorsonamission.org).



*Midwinter racing returned in a big way last month. This is the J/24 contingent of Regatta-PRO's 'Winter Keel' fleet in action.*

- Finally, Garrett Caldwell, sailing his *Tayana 47 Oceanaire*, wants to bring attention to the **Give Back a Smile Foundation**. The foundation helps victims of domestic violence reclaim their self-esteem by restoring their smiles. Check them out at [www.aacd.com/foundation](http://www.aacd.com/foundation).

[aacd.com/foundation](http://www.aacd.com/foundation).

On that note, we wish you all a healthy, happy and prosperous **New Year**. If you race, have fun but be safe. And if you're searching around for worthy resolutions, how about offering a ride to a non-racer friend, co-worker or even neighbor — and going to the extra effort to make it an unforgettable experience for them?

See you out there!

Photo: David Gartland



## SAN FRANCISCO BOAT WORKS

835 Terry A. François St., San Francisco, CA 94158

(415) 626-3275 Fax (415) 626-9172

[www.sfboatworks.com](http://www.sfboatworks.com) [sfboatworks@yahoo.com](mailto:sfboatworks@yahoo.com)

*Be our guest for lunch at the historic Ramp Restaurant\**

\*Some restrictions apply

**20-50%  
WINTER DISCOUNTS!\***  
**CALL NOW!**

- **Engine sales and installation**
- *Sprayed racing bottoms*
- *Custom topside paint*
- *Fiberglass and gel coat repairs*
- *Electrical and mechanical systems*
- *Rigging repairs and refit*
- *Wood repairs*



**YANMAR**  
marine

**Interlux**  
yachtpaint.com



**"The Raceware Specialists"**

**KNOWLEDGE**

- Shop Where Fellow Racers Work

**CONVENIENCE**

- Online Orders Save on Shipping
- Same Day Shipping
- Speedy Custom Rigging

**SELECTION**

- Largest Selection of Racing Hardware, Apparel, & Cordage In the World...Online and In Stock!



**www.APSLTD.com ~ 800.729.9767**

**Question: What's the secret to winning the Pacific Cup?**

**ANSWER: START EARLY!**

Winning takes planning and preparation. The last two overall winners started early by calling Easom Rigging. Start now! Call today.



**Easom Racing and Rigging**

1150 Brickyard Cove Rd. Suite B1  
Point Richmond, CA 94801

**(510) 232-SAIL (7245)**

**www.easomrigging.com**

**JOIN US FOR OUR MIDWINTER SERIES**

★ ALL BOATS WELCOME ★

**January 19-20 & February 16-17**

*Post-Race Festivities – Drink, Dine and Dance to a Fabulous Band*

**Information & Sign-Up at: [www.cyc.org](http://www.cyc.org)**

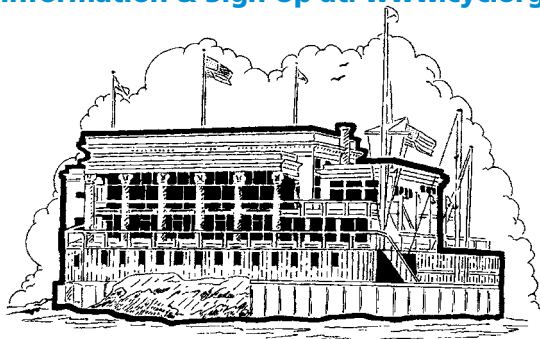

**Corinthian Yacht Club**

OF SAN FRANCISCO

43 MAIN, TIBURON, CA 94920 • **(415) 435-4771**

Visit our website: **www.cyc.org**



# WORLD

With reports this month on the differences between **Prime Charter Venues Around the World** and a frequent charterer's four-family cruise through **Rhode Island Sound**.

## Welcome to 2008 And a World of Charter Options

Whoa! Here we are at the beginning of a new year already. Time certainly does fly when you're, ah... working your tail off.

One of the cool things about January, though, is that it's a time of new beginnings. A time to clear away the clutter of the past year and start anew. A time to survey the pages of your new calendar and pencil in a little time for some much-needed R&R — ideally on a sailing vacation. In this month's column we'll attempt to help you answer the obvious question: Where to next?

As you can see by the map below, this ol' world of ours is peppered with charter bases. Needless to say, they're all located in prime sailing destinations. Late-model bareboats are available at all the spots listed and luxury crewed yachts can be found at many of them also.

Let's set your head to reeling with too many options, we'll divide our discussion here by categories or 'themes'. After all, different attractions appeal to different tastes. With bareboat chartering in mind, we'll address several key questions which are often asked of charter brokers: Which are the best venues for first-time charterers? Which offer the best sailing? Which are best for kids? Which offer the most interesting cultural attractions ashore? And which are the most exotic?

If you regularly peruse these pages

but have been just a wee bit too unsure of your abilities to commit to a bareboat charter, let us explain how easy it can be. You probably won't be surprised to find that the British Virgin Islands are at the top of our list for first-time charterers. You've heard that a thousand times, right? And for good reason. Not only are the waters well protected, the distances between anchorages short and the shore-side facilities abundant, but there are overnight mooring buoys in almost every popular anchorage. You can literally explore for two weeks without having to anchor — the most fearful maneuver for most marina-based sailors.

Although we never tire of sailing in the BVI, that British Overseas Territory isn't the only place we'd recommend to first-time charterers. Roughly 350 miles to the southeast lies a cluster of tiny islands called the Grenadines. Here too, distances between islands and anchorages are quite short and the sea state is generally pretty flat. But there's not nearly as many boaters, and not nearly as much development ashore. Yes, you will have to anchor, but with white sand beneath you in every anchorage it's as close to a no-brainer as you'll find anywhere. Besides, you've gotta learn to set the hook sometime.

Another excellent first-timer destination is the greater Puget Sound region. Whether you choose to sail in the American San Juans or the Canadian Gulf Islands, you'll find benign conditions



90% of the time; excellent shoreside facilities, including many marinas; and breathtaking panoramas. You do have to pay careful attention to tides and currents, but that's a minor challenge which we've always viewed as part of the fun.

Which venues offer the best sailing?

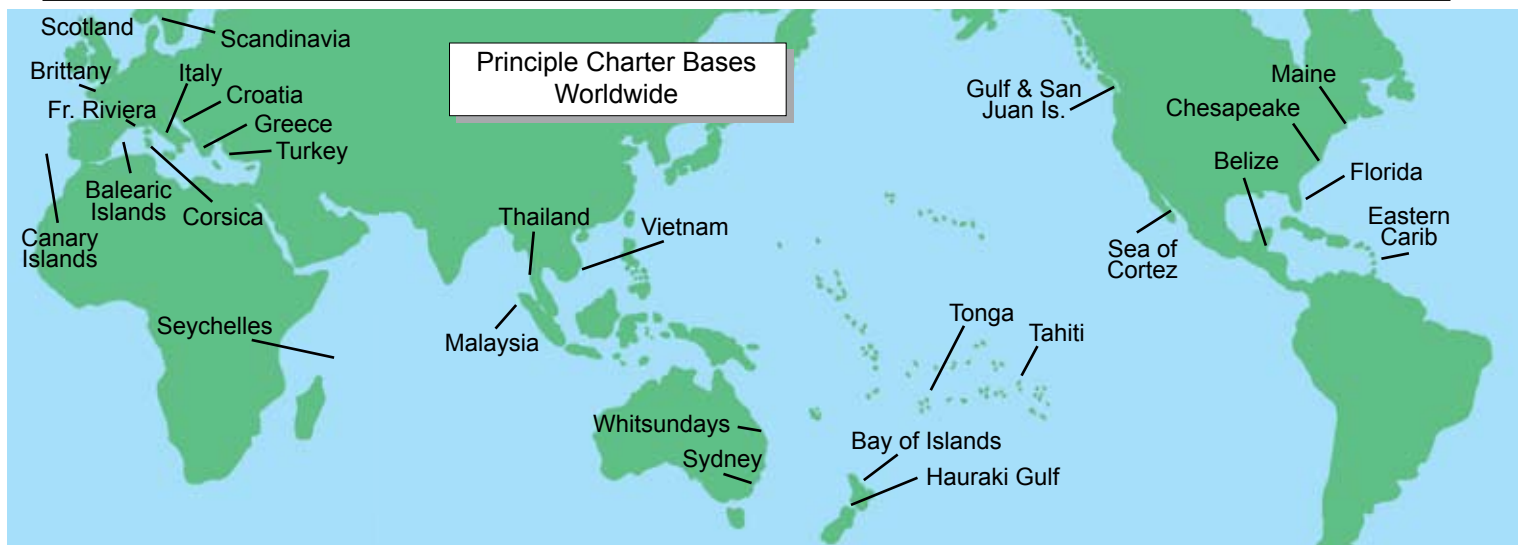

# OF CHARTERING



INSET RIGHT: GPSC

LATITUDE / ANDY

**Spread:** Charterers anchor off a 'motu' in the tranquil Raiatea lagoon. Insets, left to right: With plenty of overnight moorings available, the San Juan Islands are a fine choice for a first-time charter; chillin' is a national pastime of the BVI; the cultural heritage of Greece adds a whole new dimension to vacationing there.

We'd be fools to guarantee you'll find ideal wind and weather anywhere in any given week. That said, the trade winds of the Eastern Caribbean are about as predictable as you'll find anywhere. That's why Antigua Sailing Week and the Heineken Regatta are two of the most popular regattas in the world. From St. Maarten to the Grenadines you'll typically find ideal 12- to 25-knot conditions year-round, interrupted only by passing storms and 'tropical waves' during the June-to-November hurricane season. Where else? You can usually count on some pretty fine sailing conditions in New Zealand during their summers (our winters), as well as in the Tahitian islands, which promise tranquil lagoon anchorages combined with often-booming interisland passages. Wind strengths in Mexico's Sea of Cortez tend to cycle,

including everything from very light air to strong blows. Taken as a whole, though, there's generally plenty of nice breeze in fall, winter and spring.

Which are the best venues for kids? In our experience, the most fun young kids typically have on a charter vacation is when they're snorkeling. Find a snorkel and fins that fit your kid, let him or her splash around for a few hours in clear water over an abundant reef, and you'll have one happy kid — and one who won't give you a hard time at bedtime. Older teens and young adults tend to like the autonomy of taking off on a sailing dinghy, windsurfer or kayak (translation: escaping their parental units).

SUNSALE

With these criteria in mind, there are a lot of places that will fill the bill: the Eastern Caribbean, Belize, the Sea of Cortez, Tonga, Tahiti, Thailand, the Whitsundays, the Seychelles and even Florida. If your charter operator doesn't offer watersports toys, you can often rent them from waterside resorts.

Which venues offer the most interesting cultural attractions ashore? Here we enter a whole new realm of consideration. If some of your potential shipmates aren't die-hard sailors, but love history or simply like being surrounded by lively cultural traditions, there are a variety of destinations that will peak their interest while ashore, in addition to fine cruising under sail. Of course, anywhere in Europe is worth considering — Britany, Scotland, the French Riviera, Italy's western coastline, Croatia. . . But for true history buffs, accessing the antiquities of the Greek Isles and Turkey's Turquoise Coast is tough to beat. Closer to home, the backwaters of Downeast Maine and the Chesapeake could also be considered, as towns there date back to colonial times. And when it comes to getting in touch with genuine Polynesian culture, both Tonga and Tahiti are sure to please.

Which venues are the most exotic? By our definition of the word, Thailand and Malaysia would definitely have to be high on the list, as would Tahiti, the Seychelles and the sailing world's newest charter option, Vietnam.

Yeah, we know: So many choices, so little time. Here's an idea: Corral a group of willing charter partners and let them decide!

— latitude/at

**Whoever invented the mask and snorkel did family vacationers a huge favor. Everyone from pre-schoolers to grandparents can enjoy it.**







ART HARTIGER

*They kept the Hinckley 49 'Elizabeth' in their sights. Chartering two boats adds a whole new level of fun.*

### A Four-Family Charter Through Rhode Island Sound

We've done a lot of wonderful bareboat charters in venues all over the world, but last summer we decided to

charter closer to home. Sailing two boats out of Newport, RI, four families did a week-long cruise to Cuttyhunk, Martha's Vineyard and Nantucket.

There were eight of us board *Imagine*, a Beneateau 46: me, my wife Susan, our kids Claire, 15, and Elise, 13, plus our longtime chartering partners Andrea and Kirsi, and their kids Marco, 15, and Paolo, 13. This was our first cruise with teenagers, and we're happy to say it was not a problem.

Aboard the second boat, a Hinckley 49 named *Elizabeth*, were New Yorkers Alberto and Annemarie, with their two kids Francesco, 9, and Giacomo, 8. They were joined by our friends from London, Marco and Karin, and their kids Matteo, 12, and Daniela, 10.

We chose to charter from Bareboat

Sailing Charters, mainly because they seemed to be the only game in town ([www.bareboatnewport.com](http://www.bareboatnewport.com)). And Newport seems to be the only harbor in the area from which one can charter any boats at all. Our search for boats in other East Coast locations that are within easy striking distance of Martha's Vineyard didn't turn up any alternatives.

Unfortunately, it was raining when we gathered in Newport on a Friday evening in August. But we completed check-outs on both boats, as we planned to set sail early in the morning.

After dinner at a local Newport restaurant, we returned to the boats, and some of the crew went off to provision. Attention beer and wine lovers: things shut down at 11 p.m. in this part of the world, so plan accordingly. We made it to the liquor store by 10:55 p.m., narrowly averting a crisis, as our first stop was scheduled to be Cuttyhunk, a dry island.

We departed on Saturday morning, with clear skies and a nice breeze, reaching Cuttyhunk in the afternoon. It's a beautiful little island with an in-

The Right Equipment.  
The Lowest Cost.

Price Guarantee  
BEAT ANY OFFER BY \$100!  
888-788-0549  
[www.footloosecharters.com](http://www.footloosecharters.com)

Footloose  
SAILING CHARTERS

Monohulls and Catamarans 33' to 50'  
BRITISH VIRGIN ISLANDS

# OF CHARTERING

ner harbor which is somewhat tight, but can accommodate a few dozen boats on moorings (\$40 per night, first come, first served).

Cuttyhunk has a few great services, including a wonderful fish market (actually, more of a window), ice cream store and a raw bar. We bought some fresh swordfish and salmon and headed back to the boat for a barbecue. The raw bar boat circles through the mooring field, offering fresh clams, lobsters and oysters. We succumbed to temptation and bought some oysters and shrimp to accompany our cocktail hour. Delicious!

Our game plan was to sail to Martha's Vineyard, to spend time with some friends who have a house there, on the shoreline of Lake Tashmoo. We left in the morning, traversing Quick's Hole to Vineyard Sound, having calculated the high tide outside the lake to be at about 12 noon or so. The entrance is reputed to be narrow, with significant shoaling, and the Tisbury Harbormaster was unable to say whether we could even enter the lake, given the six-foot draft on each of our boats. But our friend Elissa

had promised to prepare both a fresh clam chowder and a lobster feed, so we were determined to make it.

We hit high tide outside the lake and, upon entering the narrow channel, promptly hit the sandy bottom. We quickly backed off, and were advised by a local boater to keep to the east side of the channel. With lobster on our minds, we tried again and, sure enough, we slipped through with no problem.

Lake Tashmoo was apparently a freshwater lake decades ago, but when it suffered a breach to the sound, it was decided to create a permanent entrance to Vineyard Sound. These days, the water inside is brackish. It is a beautiful little lake, surrounded by trees and some houses, with a number of boats moored inside. Escorted by our local friend Bob, his son Lem and daughter Anna Rose in their boat, we felt privileged to pull up



ART HARTIGER

*Elissa raises a toast over a heap of local lobsters. She whipped up a meal that will long be remembered.*

to a dock right in front of their house. Before long we were enjoying Elissa's famous homemade clam chowder, with



## Come... Escape Reality aboard the GORGEOUS LUXURY TALL SHIPS of Star Clipper

*A sailing experience,  
where the work  
is optional!*



You'll enjoy the amenities of a modern cruise ship aboard vessels which were lovingly created in the tradition and romance of legendary sailing ships. *Star Clipper* and *Star Flyer* are 360-ft long. *Royal Clipper* is 439-ft long. Seven-day cruises will take you to remote **Caribbean** islands, the enchanting **Italian and French Riviera**, the magical **Greek Islands**, exotic **Thailand**, and everyone's favorite dream destination: **Tahiti and French Polynesia!** *Special fares* are available on selected dates throughout the year.

### **Special Clipper Ship Instructions:**

Hands-On Sailing Maneuvers on Deck  
Knotting Classes  
Navigation Classes  
Dinghy & Laser Sailing

**THE CRUISE DIRECTOR, INC.**  
**(650) 592-6048 (800) 533-7111**  
email: [off2sea@pacbell.net](mailto:off2sea@pacbell.net)

Call for a  
**FREE BROCHURE!**

California Seller of Travel  
#1002066-40



# WORLD

clams taken shortly before our arrival directly from the lake.

We settled in for a couple of nights of swimming and fun. Our friends taught us how to get clams — using a rake or even your hands is cheating, according to Elissa. You've got to wade in and feel them with your toes. Within a short time, the kids had filled up a bucket with fresh clams. Later, Bob took the kids out to check on his lobster pots and they returned with four lobsters. (Three mysteriously escaped that night, however, before being plunged into a steamy pot. I suspect the numerous kids who kept checking out the cage.)

That evening, we left the kids behind and went to a Boston Pops concert that included Natalie Cole, Branford Marsalis and a guest appearance by Carly Simon. The next day included walks to nearby Vineyard Haven, outdoor showers, spending too much money at the famous Black Dog Tavern, a bike ride to Edgartown, a lobster feed with local corn on the cob, and then another music surprise: Toots and the Maytals were playing at a local joint called Out-



ART HARTIGER

**Regardless of the boat type that is chartered, kids always seem to find a place to escape their parents. Note the safety line.**

erbound. Karin and I found ourselves on stage at one point dancing with a bunch of twenty-somethings.

The next day we set sail late in the morning bound for Nantucket. We had 15- to 20-knot winds the whole way, and had a great time sailing with *Elizabeth*. While *Imagine* dutifully rounded all marks and I cooked a leisurely pasta lunch on the way into Nantucket Harbor, *Elizabeth* cut the corners and proclaimed they'd "won the race." Later, this set off a round of arguments, and so our defacto 'race committee' set a specific course for the next day's sail back to Martha's Vineyard. There was no way the Hinckley could possibly beat our Beneteau.

On the trip to Nantucket, we were joined by a red-breasted nuthatch — we nicknamed him Red — who looked very tired and glad to find a resting place some five miles or so from shore. Red stayed for an hour or so before flying off.

Although there are dozens of moorings in the harbor, they were all reserved. But we found plenty of anchoring room in a lovely anchorage. The only drawback was that we were quite a ways from the dinghy dock. The alter-

**HAVE WE GOT A CAT FOR YOU...**

**GO CATS**  
Catamaran Charters Worldwide

In North America  
Call for a Brochure  
**1.800.592.1254**  
[WWW.GOCATS1.COM](http://WWW.GOCATS1.COM)

SOUTH PACIFIC • MEDITERRANEAN • CARIBBEAN • INDIAN OCEAN

photographers: B. Picard, P. Lafabre

**Tahiti,**  
is calling you

The...  
magical seduction!    spectacular beauty!  
dazzling sunshine!    turquoise lagoons!

Charter a new catamaran for a week or more  
and cruise around the best palm trees in the world

**TAHITI YACHT CHARTER**  
P.O. Box 5162 • Newport Beach CA 92662  
949-675-3519 • Fax: 949-723-8512  
[marimktg@ix.netcom.com](mailto:marimktg@ix.netcom.com)

For reservations Call toll free:  
**1-800-404-1010**  
anywhere in USA or Canada

[www.tahitiyachtcharter.com](http://www.tahitiyachtcharter.com)



# OF CHARTERING

native was to call the Harbor Launch on VHF 68 for a pick-up. They charged \$8 per person for a roundtrip. We made the rounds at the stores, stocked up on ice and returned to the boat for a BBQ and a poker game with the kids.

The official poker winners – for every game during the trip – were Paolo and Elise. After losing, I mentioned that I had taught Paolo how to play poker in French Polynesia on an earlier family cruise. With that, Paolo smugly pointed out, "Well, as so often happens, the student has surpassed the teacher."

Nantucket has a rich history as a whaling town, but appears now to be chock full of boutiques and art galleries. It would have been nice to explore the other parts of the island, but we wanted to get back aboard and get some rest before the next morning's big race.

Both *Imagine* and *Elizabeth* weighed anchor early and headed out the narrow Nantucket channel entrance. While inside the channel, with about 15 knots of wind behind us, we saw activity on *Elizabeth*. They were setting the jib, and kids were scurrying about. We pulled



**At the peak of the summer sailing season Nantucket's dinghy dock is a busy place — but we've seen much worse.**

up alongside and learned that they had complete engine failure with a troubling amount of smoke in their engine room.

They eventually got things sorted out and we set sail for Martha's Vineyard, close hauled. The winds built to over thirty knots, with gusts to 40. Although the wind was on the nose, it was a really fun 20-mile sail.

*Elizabeth* contacted the charter company for some help in diagnosing the engine problem, and they directed us to Vineyard Haven to meet a mechanic. It turned out to be a decent anchorage even though there is quite a bit of ferry traffic. There was lots of room to anchor, in 15 feet of water.

*Elizabeth* dropped the anchor under sail, and we set ours nearby. When the mechanic came the next morning, we learned that a new part was needed, so it would be sailing only for them the rest of the way.

We picked up the anchor and headed to Menemsha for our last day. Both boats tacked their way up Vineyard Sound, with the wind on the nose under cloudy skies. We eventually took moorings right outside the mouth of Menemsha Harbor. It looked like there were six mooring balls there (apparently

ART HARTIGER

NORTH AMERICA

CARIBBEAN

MEDITERRANEAN

SOUTH PACIFIC

INDIAN OCEAN

BAREBOAT

CREWED

SKIPPERED

## WE TAKE CARE OF YOU, EVERY TIME.

At The Moorings, we handle all the details so you can concentrate on having the time of your life. It's a sailing vacation the way you want it. We help you choose the right yacht, arrange your itinerary and schedule your flights to get you to any of our exotic destinations with ease. Plus, we have the largest fleet of new yachts in the industry – custom built and equipped with you in mind.

Our 38-year reputation for integrity, quality and reliability has satisfied the most discriminating sailors. Trust The Moorings. We promise an experience you will treasure forever.



The Moorings®

The Best Sailing Vacations In The World!

Visit the most trusted name in chartering.  
www.moorings.com • 800-521-1198





# WORLD OF CHARTERING

free, as no one said otherwise), first come first served. We managed to get the last two mooring balls, and were set again for the night. *Elizabeth* expertly picked up the mooring under sail, no problem.

Menemsha is really a nice change from the T-shirt shops, art boutiques, and curio stores which seemed to be prevalent in Nantucket and Vineyard Haven (at least close to their harbors). Menemsha is low key, with a beautiful beach (although it was raining when we were there). And there is a restaurant in town, Home Port, that we loved. Without a reservation, we ordered from their 'take out' window, and sat outside (in a light rain), enjoying clams, shrimp, oysters, lobsters, and fish stew. It was extremely difficult to plow through our last four bottles of wine at dinner, but we persisted and succeeded.

Did I mention that people seem to



ART HARTINGER

***Look closely and you'll see Claire's new feathered friend, Red. He stopped by to visit and rest his weary wings during the sail to Nantucket.***

make a lot of reservations this time of year, and we made none the entire trip? If you want a mooring or restaurant reservation, you should call ahead. We did just fine making no reservations, but

this was a crowded time of year, and we like to cook on board.

Departing the next day, we had a long slog back to Newport Harbor, with fluky winds (ranging from 5 - 15 knots) right on the nose, and lumpy seas. *Imagine* motorsailed, as we had about thirty miles to go, and the boat was due back by noon. *Elizabeth* sailed, close hauled, enduring an 11-hour tacking fest.

When back in Newport, the boats had to be topped off, so we stopped at a fuel dock, filled up the water tanks, and bought some diesel. The charter company naturally relaxed this requirement for *Elizabeth*, and Alberto handily sailed the 49 footer straight up to the dock.

Our thoughts have turned to our next charter. Maine? Carib? Thailand? French Polynesia? We have some serious decision-making ahead.

— art hartinger

Tortola BVI  
Belize  
The Grenadines

**UNIQUELY  
TMM**

Marisa  
TMM Belize

Most charter companies offer blue water & palm trees, but it takes the personalized care of people like Marisa to make your vacation a success.

Like Marisa, everyone at TMM is committed to your complete satisfaction. Our specialized three-location operation offers large company quality with small company service. A combination that is uniquely TMM.

**TMM**  
Yacht Charters  
Since 1979

catamarans • monohulls  
motor yachts  
ownership programs

**GET READY  
for the  
CARIBBEAN!**

1. Pack for the sun.
2. Go to the airport.
3. Meet our friendly staff.
4. Sail away for the day or month.
5. Sunbathe. Snorkel. Wine. Dine.

**YACHTS from 31-52 feet**  
Crewed yacht charters available  
10% off to repeat customers  
Monthly specials

**B.V.I. YACHT CHARTERS**  
www.sailinthebvi.com

Joma Marina, Port Purcell, Tortola  
284-494-4289 or 888-615-4006  
fax 284-494-6552  
charters@bviyc.com

Real People. Real Sailing. Real Fun.

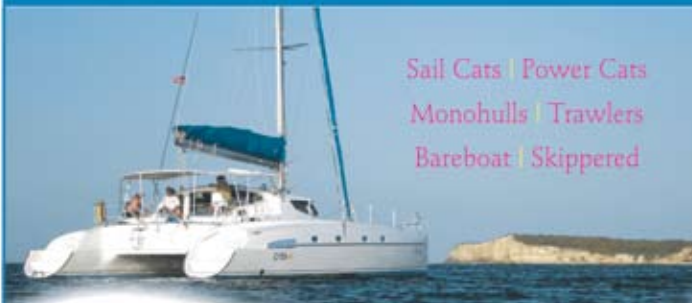

Sail Cats | Power Cats  
Monohulls | Trawlers  
Bareboat | Skippered

Real Choices.

Choose CYOA and become part of the family. We've been providing beautifully maintained yachts, personal service and sensible prices to sailors since 1980.



1-800-944-2962  
info@cyoacharters.com  
www.cyoacharters.com  
St. Thomas USVI 00802



RACE A LEGEND!



TWO-TIME B.O.C. AROUND THE WORLD RACER!  
**MIGHTY TONGAROA**  
SANTA CRUZ 50

6 CREW SPACES AVAILABLE FOR THE FOLLOWING RACES!

February 2008.....	<b>PV Mexico Race</b> .....	\$3,000+SE
	<i>Fast is Fun</i>	
March 2008.....	<b>Cabo Mexico Race</b> .....	\$2,500+SE
	<i>Potential Class Winner</i>	
June 2008.....	<b>Tahiti Transpac Race</b> .....	\$5,500+SE
June 2008.....	<b>Pacific Cup Race</b> .....	\$5,000+SE
	<i>Set a Class Record</i>	
November 2008.....	<b>Sydney/Hobart (tuneup) Race</b> ....	\$1,500+SE
	<b>Lord Howe Island/easily handled by 6-18</b>	
December 2008.....	<b>Sydney/Hobart Race</b> .....	\$5,000+SE
	<i>Boat Speeds 24+ knots</i>	
February 2009.....	<b>Great Barrier Reef/WB Race</b> ....	\$2,500+SE
June 2009.....	<b>TransPacific Race</b> .....	\$5,500+SE

CHOOSE YOUR RACE AND CALL!

- Hassle Free • Fly In/Fly Out After
- Bare Boat with your Crew or Crew with us (Syndicate)
- Delivery Space Available to Learn Seamanship from the Following Passages: Mexico, Tahiti, Cook Islands, Australia, New Zealand, Hawaii – \$1,500+SE

HIGH PERFORMANCE SAILING HAWAII

Contact Bill Boyd

(562) 714-2455 or (808) 230-5551



MAHINA OFFSHORE  
CRUISING SEMINAR



Learn the latest practical and rewarding aspects of cruising from accomplished world cruisers and instructors John and Amanda Neal.

Seattle, WA: March 1, 2008  
Oakland, CA: March 8, 2008

Six months a year John and Amanda conduct sail-training expeditions worldwide aboard their Hallberg-Rassy 46, *Mahina Tiare*. This seminar incorporates the knowledge gained from their combined 472,000 sea miles and 63 years experience.

Topics include: Choosing the Right Boat, Equipment Selection, Storm Avoidance and Survival, Safety & Medical Concerns, Communications, Anchoring, Galley Essentials, Managing Your Escape and Cruising Routes Worldwide.

9 hours of detailed instruction follow the 265 page Offshore Cruising Companion.

Details and online registration: www.mahina.com,  
or call 1-800-875-0852, 206-283.0858, fax 206-285-1935



BRITISH VIRGIN ISLANDS  
"BEST DEALS ON KEELS"

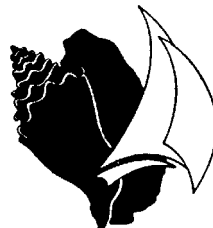

Conch  
Charters

Est. 1986

- Most selection of sailboats 32'-52'
- "Purr" with cats 37'-45'
- Bare boat or skippered
- Best yacht management program



www.conchcharters.com

Email: sailing@conchcharters.com

Call our 'Sails' Office

(USA) (800) 521-8939

Tel (284) 494-4868 • Fax (284) 494-5793

Sail paradise with Conch Charters

CALIFORNIA'S CARIBBEAN CONNECTION



# JUST YOU AND THE SEA...

## Punta Mita Beachfront Condos

*Call now for reservations!*

1.415.599.5012

[www.puntamitabeachfrontcondos.com](http://www.puntamitabeachfrontcondos.com)

## PACIFIC OFFSHORE PASSAGES AND PRIVATE CHARTERS

57' Steel Cutter. Custom Built 2002 in BC, Canada.



CHARTERS: Mexico • BC, Canada • Offshore  
Trips available for groups, individuals or couples

- Puerto Vallarta to Zihuatanejo Jan. 14-29
- Mexico to Hawaii March 31 – April 22
- Hawaii to Victoria, BC April 28 – May 21
- Around Vancouver Island June 7-21 & Sept. 6-20
- Victoria, BC, to San Francisco Oct. 2-10
- San Francisco to Cabo San Lucas Oct. 16 – Nov. 7

Sailing Yacht Western Grace  
[www.WesternGrace.ca](http://www.WesternGrace.ca)  
800.664.6049 / 808.271.3540

## MARINA REAL

**SAN CARLOS, SONORA, MEXICO**

### IN THE SEA OF CORTEZ

Located on the Mexican mainland near  
Guaymas and San Carlos, 265 miles south of  
Nogales, Arizona.

- 350 slip marina • 20 & 30 amps electrical service
- 24-hour security patrol
- Fuel dock with gasoline/diesel
- Restrooms & showers
- Web email • Fax/copy service
- Port entry clearance
- Book exchange • Video loan library
- Ice & bottled water
- Wet storage for summer months (low prices)

**Now Offering:**

**Haulouts, Dry Storage & Service Yard**



Phone/fax 011-52-622-2270011  
Call on VHF #16 when in area  
email: [marinareal@prodigy.net.mx](mailto:marinareal@prodigy.net.mx)

Visit our website:  
[www.marinareal.bravehost.com](http://www.marinareal.bravehost.com)

# SAN JUAN ISLANDS SAILING SCHOOL

Fly to Bellingham, WA  
Explore the spectacular San Juan Islands!

## Week-Long Learn-N-Cruise

During your live-aboard week out in the islands, you'll complete American Sailing Association's Basic Sailing through Bareboat Charter Certification.

Tax Exempt Tuition Only **\$1295** Includes Food!  
(Airfare SFO/OAK to BLI approx. \$300)

No Experience like this for the price in the SF Bay Area!

**1. 800.677.7245**  
**www.sanjuansailing.com**

SCHOOL



CHARTER

40 Exceptional Yachts  
from 31 - 49 feet

25 Years of Sailing Excellence

We certify more Bareboat Skippers than any other school in the Northwest!

# We fell in love...

*with the San Juan Islands.*

*My husband and I took our vacation with ABC Yacht Charters. It was the best vacation of our lives. After experiencing the beautiful San Juan Islands, we fell in love.*

**800.426.2313**  
[www.abcyachtcharters.com](http://www.abcyachtcharters.com)



# ABC YACHT CHARTERS

## Maine Cat 30 & 41 Hope Town, Abaco, Bahamas Bareboat Charters

Enjoy well protected Sea of Abaco waters with their beautiful islands and beaches aboard an open bridgedeck cruising catamaran. A breeze to handle and fully equipped.



[www.mecat.com](http://www.mecat.com) or [www.mainecatcharters.com](http://www.mainecatcharters.com)

New email: [info@mecat.com](mailto:info@mecat.com)

Phone: 1-888-832-CATS



**Closest full-service charter base to Desolation Sound & Princess Louisa Inlet**

Visit our Web site for a preview of our 25' to 54' Power & Sail fleet

Book your 2008 charter now and SAVE!

e-mail [charter@desolationsoundyachtcharters.com](mailto:charter@desolationsoundyachtcharters.com)  
<http://www.desolationsoundyachtcharters.com>

#101-1819 Beaufort Ave., Comox, BC, Canada V9M 1R9  
TOLL FREE 1-877-647-3815 FAX (250) 339-2217



## YACHT CHARTERS IN GREECE, TURKEY & CARIBBEAN

**Best Rates For Reliable Charters**  
Full services: Low fares, hotels, tours, transfers

Visit our website for yacht photos and details, destinations and itineraries:  
[www.albatrosscharters.com](http://www.albatrosscharters.com)

**SAIL AND SCUBA DIVING IN GREECE**

Sailboats • 30'-60'  
Bareboat/Crewed  
Monohulls & Catamarans  
Luxury Sail & Motor  
5 to 60 Guests

**Albatross** (800) 377-8877  
An American owned and operated company (856) 778-5656  
Box 250, Moorestown, NJ 08057

## ANACORTES YACHT CHARTERS

PACIFIC NORTHWEST ADVENTURES

Enjoy Yachting for a Lifetime with the World's Best!

*Rated #1 by Cruising World*



*Largest Selection in the Pacific Northwest*

Bareboat & Skipped Power and Sail 28'-66'

Charter Yacht Ownership

Yachting & ASA Sailing Schools

**www.ayc.com**  
**800.233.3004**



# CHANGES

With reports this month from **Hawk** at Puerto Montt, Chile; from **Night Heron** on surviving the Caribbean 1500 with not much sail; from **Meridian** on launching baby turtles in Mazatlan; from **Coco Kai** on working through Ecuadorian red tape; from **Southern Cross** on the continuing fun on Fanning Island; from **Sea Angel** on the passage from Bermuda to St. Martin; from **Snow Goose** on Thanksgiving at Isla Isabella; and a whole locker full of **Cruise Notes**.

**Hawk — Van de Stadt 47  
Evans Starzinger & Beth Leonard  
Puerto Montt, Chile  
(Annapolis, Maryland)**

Evans and I have enjoyed another challenging and rewarding year. In the last 12 months we've sailed almost 12,000 nautical miles, visited four countries and, upon reaching Puerto Montt, Chile, in October, have closed the loop on our second circumnavigation. Since we were last here in Puerto Montt five years ago, we've put more than 40,000 nautical miles beneath *Hawk's* bottom, a third of that in the Southern Ocean. We've now sailed more than 100,000 miles in our two boats, almost two-thirds of it in high latitudes with *Hawk*.

To review our last year, we spent Christmas in Mag Bay on the west coast of the Baja peninsula with a wonderful group of new-to-cruising couples, and became good friends with them. We then rounded the tip of Baja, and just after New Year's, stopped at La Paz for a couple of weeks so Beth could refresh her Spanish by taking an intensive course. After that, we enjoyed a six-week winter cruise in the Sea of Cortez, followed by an inland trip to visit the Mayan ruins in Chiapas, Mexico's southernmost state.

In April we departed the Sea of Cortez for Costa Rica. We took the offshore route, making just one short stop in Zihua to clear Customs and top up with

**Beth, seen here with Evans, won the National Outdoor Book Award in Outdoor Literature for 'Blue Horizons'.**

fuel, water and produce. The Gulf of Tehuantepec is dreaded for sometimes strong winds and big seas, but we motored across in flat calms, surrounded by pods of dolphins, dozens of sea turtles, and hundreds of seabirds. Upon arriving in Bahia Santa Elena in the north of Costa Rica, we were serenaded, morning and night, by flocks of scarlet macaws.

We had planned to spend a month or so in Costa Rica before moving onto Ecuador, where the summer climate is much cooler and drier. Unfortunately, the officials in Ecuador make it exceedingly difficult to visit by yacht, so we spent three months, from the end of April to the end of July, in Costa Rica. It was unbearably hot and humid, with almost daily thunderstorms, but the wonderful wildlife experiences more than made up for it.

Ecuador's new regulations affect the Galapagos Islands as well, so when we left Costa Rica, we sailed nonstop to the Gambier Islands. This is a small archipelago in French Polynesia that's located about 800 miles southeast of Tahiti. We'd always wanted to visit these remote islands, but they'd never really been within reach of any of our sailing routes. It took us 24 days to cover the 4,000 miles between Costa Rica and the Gambiers, but once there, we spent a month enjoying the coral atolls. From there, it was another 3,800 miles — in 24 days — to Puerto Montt, Chile, and included weathering two gales during the last four days of the passage.

We left *Hawk* at Marina del Sur, the marina where we wintered the last time we were here, and returned to the States for a short visit.

We've just applied for our cruising permit, so, weather permitting, we'll begin a three-month voyage from Puerto Montt to Puerto Williams — the latter 60 miles north of Cape Horn — at the end of the week. We plan to spend the southern winter in the Beagle Channel at the very bottom of South America. In October or November, our intention is to make the passage to South Georgia Island, where we hope to spend a month. After that, we'll head back up the Atlantic, for



what will likely be the end of this voyage.

— beth 12/10/07

*Readers — During the couple's trip back to the States, Beth received word that her book Blue Horizons had won the prestigious National Outdoor Book Award in the Outdoor Literature category. Her book is only the second sailing book to win in any category, and the first to win in the literature category. Congratulations!*

*As for deciding that officials had made Ecuador too difficult to visit, there are opposing views later in this month's Changes.*

**Night Heron — Brewer 52  
CiCi Sayer, Crew  
An Adventurous Caribbean 1500  
(Two Harbors, Catalina)**

The East Coast version of the Baja Ha-Ha is the Caribbean 1500 from Hampton, Virginia, to Tortola in the British Virgins. This was the 18th year, and 69 boats participated. Unlike the Ha-Ha, which almost always has benign weather con-



LATTITUDE/LADONINA

# IN LATITUDES



KARL MATZKE

***In the last five years, Evans and Beth have put 40,000 miles beneath 'Hawk's' keel — even a few of them on San Francisco Bay.***

ditions with light winds from aft, 1500s tend to have periods of much stronger winds and bigger seas, the wind can come from any direction, and you have to cross the Gulfstream. Furthermore, the 1500 is not only twice as long as the Ha-Ha, there are no stops along the way — except for those who seek shelter in Bermuda.

After another summer of driving a shoreboat at Two Harbors on Catalina, I joined owner Jeff Edwards and several others — who all proved to be terrific — for the trip. We started on November 4, just after hurricane *Noel* had passed Virginia. The passing of the hurricane seemed to create a vacuum in its wake, as we enjoyed sunny weather with light winds for the start. Apparently this is something of a novelty for the 1500, as evidenced by the comment, "We've finally been able to take photographs of a 1500 start!" Over the years, starts have had to be delayed by as much as several days

to wait for safe sailing conditions.

Our first three days of sailing were easy, as the conditions were easy. That all changed when a low formed off Bermuda and a front created squalls for the boats — such as ours — toward the back of the fleet. By midnight, the wind was up to 35 knots and gusting to 40, and the seas were running 15 feet. But sailing with the main double-reefed, we were pretty comfortable given the conditions.

At 1 a.m. — when else? — I was awakened by the sound of flailing sails and the watch attempting to further shorten sail. But by then it was too late. With a loud 'Pop!', the genoa exploded in a 50-knot gust. About the same time we were struck broadside by a wave that had enough force to sheer the mounts of the 500-lb, 14 kw generator, jerking her three feet to the side and against the main engine. Our port tank was also ruptured, and we began to lose diesel at a frightful rate. And just for kicks, our high water alarm sounded, setting off a frantic search for the source of the incoming water. It turned out that seawater had been pouring into the chain locker all along,

and that the bilge pumps had finally clogged. Shame on us for allowing both of those things to happen unnoticed!

When dawn finally broke, we were able to assess the condition of our sails. The genoa was a total loss, having been completely shredded. But if we were careful, we found that we could still use about 10% of the main. So with just a staysail and a tiny bit of main to work with, you can imagine that we were a little underpowered for the long — and what proved to be very slow — sail the rest of the way to the British Virgins. We thought about diverting to either Bermuda or the Carolina coast, but with bad weather in the way to both those ports, we decided to continue on to the tropics. Naturally we reported our status to the folks at the Caribbean 1500 — and were shocked to learn that a number of other boats were in even worse shape than *Night Heron*!

Unfortunately, our list of problems seemed to grow by the hour. Silly me, I'd thought that we could throw our 'to do' list away once we'd left the dock. As soon as the weather settled a little, we transferred our remaining fuel to the starboard tank, using our oil change pump and a water hose. Yes, we'd had to get creative. We finally managed to get the generator off the engine and back where it belonged — but it required using a 5-foot long 2x4 as a lever. The 2x4 was then attached to the stringers to keep the generator from sliding sideways in the still-large seas.

As we continued southeast to our destination, the weather deteriorated each night, so sleep was almost impos-

***When surfers shred, it's a good thing. But when headsails shred — as was the case with 'Night Heron' in the 1500 — it's not so good.***



CICI SAYLOR



# CHANGES

sible. But we eventually all became so exhausted that we could have slept through a hurricane. Given our badly out of balance sail plan, it was understandable that our autopilot couldn't steer in any gusts or if the wind was forward of the beam. As such, we had to do a lot of hand-steering in all conditions. I'll say one thing for having done this trip, driving in 40 knots doesn't scare me anymore. Fifty knots, yes. But 40 knots is doable.

After five days of sailing to conserve our dwindling fuel supply, and with our generator still out of commission, we began to live by the mantra of most cruisers: Conserve! Conserve! Conserve! On the fifth night after the initial squall, we found ourselves in yet another bout of bad weather, with virtually no control over the boat. Although the pointy end of the boat was headed southeast, *Night Heron* was making three knots due west! In a 24-hour period, we'd been blown 50 miles off course. It suddenly began to look like we'd have to make landfall at Cuba — no matter what the Bush administration would think. But the weather soon moderated considerably, and we decided to motorsail toward our goal. Then the wind miraculously came out of the northwest, the perfect direction, at a very pleasant 15 knots, which allowed us to kill the engine, make good time, and actually enjoy ourselves. By this time only three of the 69 boats were behind us. All of them had major issues, from water in the fuel to blown sails — and sometimes both!

Before long, the wind came out of the south at a very mellow 10 knots, but by that time we were within striking distance of Tortola, so we fired up the

*After a couple of seasons of driving shoreboats at Catalina's Two Harbors, Cici was looking forward to a sailing adventure. She found it!*



LATITUDE/RICHARD

engine once again and made a beeline for the finish. We arrived at Road Town on the 19th of November, having averaged only about 100 miles a day, not bad given our situation. We made quite a spectacle upon arrival, as we'd been unable to lower our shredded headsail, and therefore looked a bit like a pirate ship after a losing battle. Nonetheless, we received a good round of applause by the many folks who had been waiting for us.

Once secure at Village Cay Marina, we reviewed the trip to see what we could have done better. There were many things. While we had reefed early enough, two reefs hadn't been sufficient for the conditions. Heaving to would have been preferable to carrying on as we did. Falling off course and running with the wind may also have been a better option. We also learned the importance of checking the bilges on a regular basis, and not assuming that the bilge pumps would be clear and working. By the way, after 'the incident' we instituted a rule that, whenever the wind blew in excess of 30 knots, two crew had to be on deck, one to keep watch, one to check on the bilges and pumps. On the good side, we also learned that *Night Heron* sails pretty darn well with handkerchief-sized sails!

I've always believed that it's not a matter of if the world will go to shit, but when. And that when it happens, it will be in three seconds flat. Sadly, I was right in this case. Happily, I can say that the gods of the sea were kind and didn't cause us any harm other than to our pride and the owner's pocketbook.

— *cici* 12/10/07

## **Meridian — Tayana 48CC Cutter John and Nancy Powers & Family Launching Baby Turtles (Napa)**

After completing the Ha-Ha, we headed up to La Paz for Thanksgiving, then crossed the Sea of Cortez to Mazatlan and Marina El Cid. It's nice here. Maybe too nice, as we're getting very comfortable here and our girls, Maddie, 8, and Sophie, 6, are loving the swimming pool.

While listening to the morning cruisers' net the other day, we heard that baby turtles would be released to the sea that afternoon at 5 p.m. on the beach in front of the Aqua Marina Hotel. We didn't know what it was about, but it sure sounded interesting. We grabbed a bus around 4:30 p.m., but couldn't quite get to the hotel because of road detours being set



up for some kind of race the following day. So the bus driver, on the advice of several locals, encouraged us to get off at a stop a few blocks from the beach. When we got off, we followed what was an unusually large number of people heading to the beach at that time of day. And once there, we saw hundreds of people — mostly locals — lined up behind a rope that was stretched along several hundred yards of sand.

Joining the masses, it wasn't long before some official-looking guy went through the crowd handing out baby turtles. Maddie and Sophie each got two. We could tell that the girls weren't really sure how to feel about having these squirming little fellas in their hands, but they held on. It was amazing, as these very small very young turtles were absolutely driven to make their way out into the ocean.

The moment finally came for everyone to set their turtles gently in the sand. Then we watched as they raced — we're being generous here, as they are, after all, turtles — toward the water. Some

# IN LATITUDES

ALL PHOTOS COURTESY MERIDIAN



**Spread; Crowds line the beach at Mazatlan to watch the turtles being launched. Insets; Sophie and Maddie, and a man from a TV crew.**

charged full speed ahead without a break, and were gone as soon as they reached the waves. Others seemed to become a little tuckered on their journey to the sea. And a few others pretty much gave up from the git go. Fortunately the turtle herders — or whatever the organizers were called — eventually scooped up the laggards and moved them a bit closer to the water. Contact with the water seemed to revitalize the little guys, and they instantly charged further into the sea. Once the turtles were in the water, they could really move out. Before long, we could no longer see them or their rapidly moving flippers.

Maddie later told me that she thought the turtles were all going to be very large, and that they were going to have to use a crane to lower them into the water. After all, nobody mentioned anything about baby turtles. Well, that would have been fun to see, too.

In the December *Changes*, you ran an

article on the new Singlar Marina in La Paz. We'd like to add some very positive comments about another new Singlar Marina in Mazatlan, which apparently is very similar in layout and facilities to its sibling in La Paz. Located next to Marina Mazatlan, Singlar Mazatlan has beautiful new docks, power, water, diesel, and a combo hot-tub/lap-pool. Future additions include an outdoor bar, a cruisers' lounge, and a small restaurant. The docks receive a weekly cleaning, the grounds are very well-kept, and the Singlar staff has been just great, making us feel very much at home.

Although Singlar Mazatlan doesn't have as many slips as neighboring Marina Mazatlan or the nearby El Cid Marina, it can still accommodate about 25 boats up to 60 feet. And if you need work, it's nice to have a boatyard right there. They have a big Travel-Lift, offer excellent painting services, and it's also the site of Total

Yacht Works first-class diesel repair service. As such, Singlar Mazatlan is a smart choice for boats needing TLC.

Our intent was not to write a puff piece for Singlar Mazatlan; we're just satisfied customers who would like other people to know about the resource. The large following seas in the early going of the Ha-Ha convinced us that we needed to beef up the mounting for our autopilot, but we weren't sure we'd be able to find someone to do the work. Boy, were we wrong! We had the work done here at Singlar Mazatlan, and it was very professional, as well as on time and under budget.

— nancy 11/29/07

*Readers — Several years ago we participated in the launch of baby turtles near Nuevo Vallarta. What a fantastic experience, as those day-or-two-old little fellas really are cute and full of life. But nature is cruel, for it's our understanding that the mortality rate is over 90% in the first year.*

## **Coco Kai — 65-ft Schooner Greg, Jennifer and Coco Ecuador Red Tape Isn't Too Bad (Long Beach)**

We on *Coco Kai* are rebellious buccaneers — and very proud of it! If we listened to all the negative comments about places we wanted to go, or when we wanted to go to them, we'd have missed a lot. That includes Ecuador. Since we're always one step ahead or behind the pack, we've enjoyed uncrowded anchorages, no problems picking up moorings without reservations, and travelled inland when it wasn't busy.

Let's focus on our experience with Ecuador. Just about everyone who had

***Coco's got the bug! The schooner's namesake loves her sea life, both in the wild and on her dinner plate.***



COCO KAI



# CHANGES

been there — and even those who hadn't — tried to convince us not to go. But if we insisted, they warned, we needed to be sure to travel with full diesel tanks because no fuel would be available there. Well, after eight straight days of rain in western Panama, we couldn't take it anymore, and on just 12 hours notice set sail for Ecuador. It was a month earlier than we'd planned, but both we and our schooner needed to dry out. It's true that our 300-gallon fuel tanks only had 20 gallons in them, but I didn't worry about that. And while we knew in advance that the pilot at Bahia Caraquez wouldn't be available for at least two weeks, we figured we could kill the time at some nearby islands. At least it wouldn't be raining there like it was in Panama.

We beat down to Bahia Caraquez in five days, only motoring for a few hours to clear Punta Galera. The last boat we talked to had taken two more days to complete the same passage, so that wasn't a problem. What was a problem was that our Winlink communication system went down enroute — ironically, on the same day that my ham license expired. As such, I lost contact with Tripp Martin, the cruisers' friend at Puerto Amistad in Bahia Caraquez.

So we anchored at Punta Pasado for one night, then sailed south to be able to reach Martin on VHF. He reported that the pilot was expected back in a week, so we went off to Isla de la Plata. The email came back up a couple days later, so I knew they hadn't shut me off. After a week, Martin told us that it would be another week before the pilot returned, so we should go ahead and check in at Manta, and he wouldn't charge us another \$150 in agent's fee when we

***In the first 6,000 miles, Greg didn't lose any leaders catching nice fish like this. Once he got to Ecuador, he lost lures left and right.***

got to Bahia Caraquez. Manta, for those keeping score, is the largest tuna fishing port on the west coast of South America. We were escorted into the harbor by a *panga*, and directed to anchor in a spot right in front of the yacht club. It was a Saturday, so I waited until Monday to try to check in.

Checking in wasn't too complicated in Manta. First, I, Greg, crossed the street and walked two minutes to the port captain's office, where they told me that I needed an agent. They gave me directions to one down the street. But I went back to the yacht club where I met Martin, who had come to Manta to discuss the problems with the pilot for Bahia Caraquez. After we met, he called the B.O.W. Agency for me, and set up a meeting at the club for that very afternoon. I met with the agent, gave him my paperwork, and he set up an appointment with all the officials to meet at the club the next day. Sure enough, the Port Captain, Immigration, and Customs folks — as well as my agent and an interpreter — showed up right on time. It took them about 40 minutes to fill out the paperwork. A boat stamp would have been very handy, as I had to sign four sets of 11 pages of forms! They took our passports, but left a phone number we could call in case we had a problem and needed them before they had time to stamp and return them. As it turned out, they returned our passports that very night, and we received our *zarpe* a couple of days later.

In other words, we didn't have to go further than 200 feet to get our paperwork taken care of. The costs were as follows: \$150 for the agent; \$30 for Immigration — although others have been charged different amounts — and \$6.84 for the Port Captain. There is also a light and buoy fee of \$.73 a ton, but for some reason we weren't assessed that. On the other hand, when we later continued on to Bahia Caraquez, the port captain there charged us another \$6.84 for his services. But big deal.

As things now stand in Ecuador, you are supposed to have an agent to check you in and out of any port that has a port captain — which would mean an additional \$150 each time. That's shades of the



bad old days in Mexico, but hopefully that will change in the near future. But the thing to remember is that you can have a great time in Ecuador based out of Bahia Caraquez. If you go there, Tripp will be your agent — although you'll still need to either make a \$30 cab ride — or four \$4 buses — to Manta in order to get your passports stamped.

We ultimately crossed the bar and entered Bahia Caraquez without the aid of a pilot, but only because the pilot was going to be delayed even longer, and because we were given special permission. But crossing the bar without a pilot is something that I wouldn't recommend. As I explained in a December *Lectronic*, I screwed up my mental picture of the turns I had to make in order to get in, and ran aground. Fortunately, it was a soft bottom and we got off easy. We were really lucky.

Former cruiser Tripp and his crew at Puerto Amistad are great hosts. The moorings are just \$7/day, and every morning he gets on 69 to ask if anyone needs water — tap is \$.50 and purified



# IN LATITUDES

BOTH PHOTOS LATITUDE/RICHARD

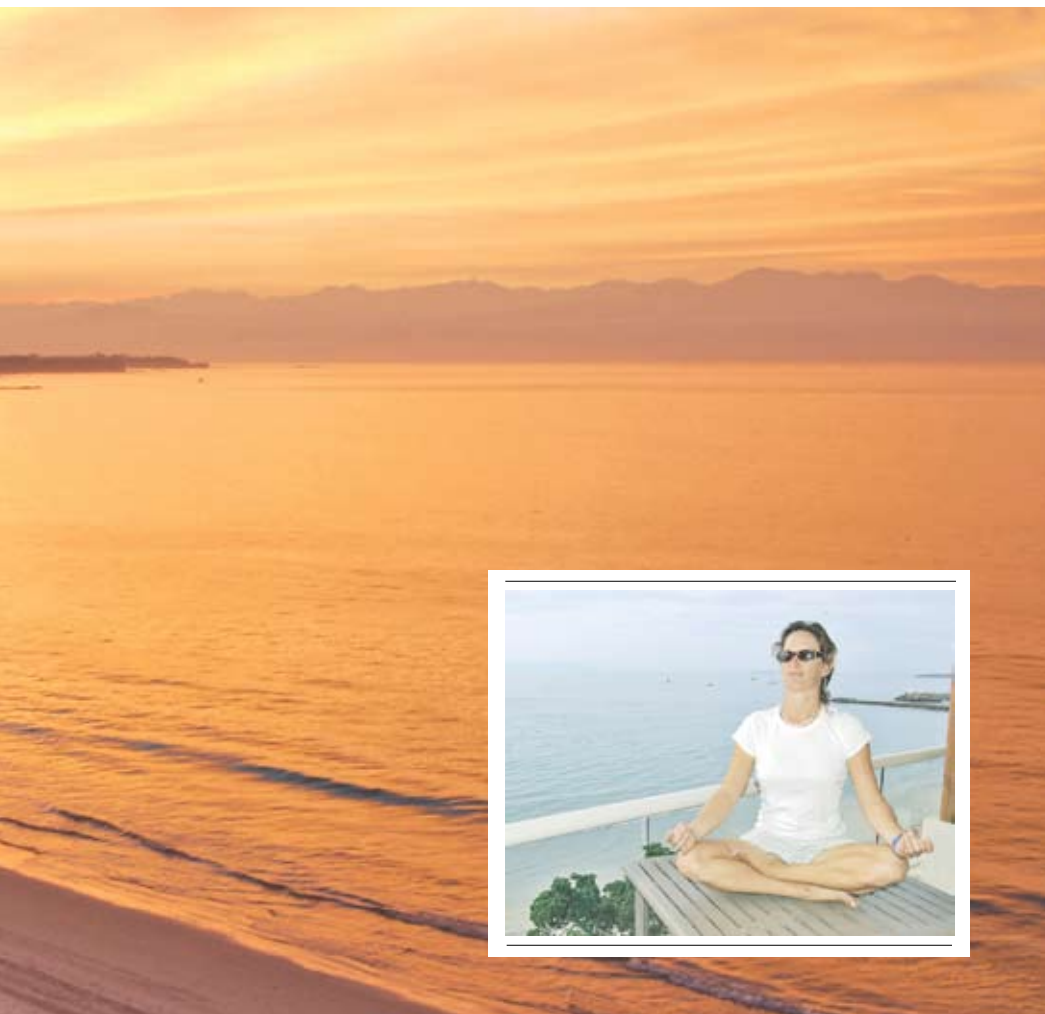

*Check out the colorful winter sunrise that is typical of Banderas Bay and much of coastal Mexico. With dawn temperatures in the mid-70s, no wonder folks such as Eugenie Russell, Commodore of the Punta Mita Yacht & Surf Club, and longtime sailing instructor at J/World Vallarta — love it.*

is \$1.75 for five gallons; laundry — \$.35 per lb; propane — \$6 up to 25 lbs.; gas — \$2 gal.; and diesel — \$1.50 gal. Everything is picked up at your boat and delivered back. They have a Whaler with a 100-gallon fuel tank, so we had them make several trips and bring us 240 gallons. So much for not being able to get diesel in Ecuador! However, Ecuador is not sure that they should be subsidizing the cost of fuel for American cruisers, so the diesel price might double from \$1.50 to \$3/gallon in the future.

Speaking of prices, one pleasant surprise is that the price of everything is about half the cost of that in Costa Rica! In addition, you can have a young man clean and polish your boat for \$7/day — and he'll be happy for the work. There is also much less theft in Ecuador than in Costa Rica.

Our sailing in Ecuador has been the best we've had in 13 months! It's blown 8-16 knots from the southwest day and

night about 95% of the time. As such, we've done more overnights here than ever before. Instead of rushing to get somewhere during the day, we leisurely do 40 to 70-mile passages at night, knowing it's going to blow all night. It's true that there are a lot of fishing boats, but the unlit smaller ones stay out of your way. As for the fishing, I've had hand lines out everyday we've been underway since California, and hadn't lost a lure in 6,000 miles — until we got down here. Then I lost eight lures in a 40-mile stretch outside of Bahia. Killer fish? I don't know. Someone mentioned that there are lots of swordfish around here, which may explain the frayed

steel leader that I pulled in one day. As it is, I'll need to get a new supply of lures before we head across the Pacific. By the way, the surfing season is just starting down here, and I hear the waves are great and uncrowded.

We'll be here until about March 1, at which time we'll set sail for the South Pacific.

P.S. We loved *Latitude's* response to the 'Annual Ha-Ha Whiner's Letter' in the November issue. I've have been sailing the Sea of Cortez and mainland Mexico since '95, and have logged many thousands of miles on many boats, including doing the Ha-Ha on the Newport Beach-based *Moontide* in '05 and on *Coco Kai* in '06. It's been my experience that the 'whiners' are usually the ones "clogging the marinas" and who are doing very little, if any, serious sailing. We love *Latitude*, so please keep up the good work!

— greg, jen and coco 11/26/07

*Readers — Next month we'll have a letter from the Glesers of the Alameda-based Islander Freeport 41 describing their experiences clearing out of Ecuador. It was reminiscent of the bad old days in Mexico, nonetheless, they say they wouldn't have missed Ecuador for anything.*

## **Southern Cross — Angleman Ketch Rob & Lorraine Coleman More Fun At Fanning (Honolulu, Hawaii)**

We continue to be very active and having the time of our lives at Fanning Island, which is 900 miles southwest of Hawaii. On Friday night we went to the party at the Norwegian Cruise Line compound, where they served BBQ

***Rob at Fanning Island, one of those most at risk from global warming. Its maximum elevation? Just 10 feet.***



SOUTHERN CROSS



# CHANGES

steaks and potatoes! And wine! You don't normally find that stuff on Fanning. Then we dove the pass with the delivery crew of the 59-ft *Free Range Chicken*, during which time we saw manta rays, barracuda and other fish. We also had to hurry up and give a box of mail to *Chicken* to take to Hawaii for us. While doing this, we got 'stuck' having fresh tuna dinner with them and hearing great sea stories.

*Kawai*, the cargo ship from Hawaii, also arrived today and started unloading, so there was a frenzy at the dock. We're going to wait a day or two until that's over. But they've offered us water, which is a good thing. It hasn't rained here since July.

This weekend we attended the grand opening of *Maneba*, the Norwegian Cruise Line School. All the grammar school children sang, danced, and did skits. It was wonderful! We were the invited guests, and had the front row 'seats' — meaning new hand-woven pandanus mats on which we sat yoga style. When the presentation was over, the mats were gifted to us.

***Are there any women who enjoy all aspects of the cruising life more than Lorraine Coleman? It would be hard to imagine.***



At noon there was a feast/feeding frenzy. Everyone brought a dish to include with all the others. Kathy and Jeff from *Bold Spirit* gave us 10 pounds of instant mix with which to make 200 pancakes, so we cooked them up the night before grand opening with our Kiribati family. We started with an open fire over an old stainless steel fuel tank, which turned out to make a very good griddle. When we served the pancakes the next day, they were gone in five frantic minutes. In addition, there was all the usual island food — fish, rice, octopus, and chickens. The chickens were gone in two minutes. One woman put a whole chicken on her plate! In addition, there were both fried and boiled breadfruit, corned beef, babai and, because they were in season, lots of papayas.

Then it was time to twist — Kiribati rock 'n roll. Everyone — big, little, young, old — dances. We danced every dance and were quite the spectacle, so everyone wanted to dance with us. The dancing went on for two hours, at which point it was time for everyone to go home. So everyone climbed into the back of open trucks and rode down the copra road to the ferry landing. Then it was time to cross the pass in the overloaded 'ferry'. The ferry is an old aluminum landing craft powered by a 40-hp outboard, so it's not the kind of ferry people commute on across San Francisco Bay. The front of the ferry is broken, so the water rushes in over everyone's feet. That's quite an experience the first time, but we'd gotten used to it. There was singing on the ferry, just as there had been in back of the open trucks.

Borau, our adopted Kiribati child, had a sleep-over on *Southern Cross* recently. He got to sleep in a sleeping bag in the cockpit on our new pandanus mats. Big fun! Borau eats our different food, does chores with us, swims and dives with us, loves listening to our music, and is experiencing a very different life on our boat. It's quite an education, as, for example, he found out that a boat is always work. We don't sleep all day!

Yesterday Robbie caught another barracuda, while Borau and I dove in the pass with our spears. Borau and I speared the first lobster. He then climbed three trees to get drinking coconuts. The guys drank one on shore, then schlepped the rest back to the boat. By then I had the fish filleted and the lobster



cleaned, and it was time to eat. Delicious food! After lunch, Borau fell asleep, Robbie worked on the computer, and I did dishes and other chores. This was followed by another beautiful sunset. Borau would have loved to spend another night on *Southern Cross*, but it was time for him to return home as he had school the next morning.

There is no Thanksgiving Day in Kiribati, but Robbie and I are thankful every day to be well, healthy and peaceful. We're out of bananas and are hoping to get some more, but that's about our biggest worry.

— lorraine 12/06/07

**Sea Angel — Peterson 44  
Marc Hachey  
Bermuda To St. Martin  
(Auburn)**

It's sooooooooooooo good to finally be back in warm weather!

After sailing my boat from California to the Caribbean, then cruising six months a year here for many years, I decided to sell my boat last year. But when she hadn't sold by June, I decided to sail up to New England for the sum-



ALL PHOTOS COURTESY STEVE SIDELLS



**After a New England (top inset) spell where the water was cold, Marc was happy to return to the warm and blue Caribbean (lower inset).**

mer. It can be cold up there!

The last leg of our trip back down to the Caribbean was from Bermuda to St. Martin. It's 860 miles, and we covered it in 5.5 days. That's pretty good for *Sea Angel*, but the wind averaged 25 knots, except during squalls, which either caused the wind to increase or decrease for brief periods. But 95% of the time the wind was on our beam or aft of the beam — and mostly aft. As a result, we had mostly following winds and following seas, which made for fantastic sailing. The only downside was the 8 to 12-ft seas, which caused the boat to do a lot of rocking and rolling. Periodically we had waves break on the beam — and you wouldn't believe the explosive sound it made inside the hulls! If I didn't know how stout *Sea Angel* was built, I might have been a little worried.

Other than the autopilot overheating one night, which resulted in an accidental jibe, we didn't have any damage that required repairs. I always put a preventer on when we're in following seas such as

we had, so there wasn't any damage. But I'd been down below and off watch when it happened, so I had to come on deck and straighten things out. The autopilot wouldn't work anymore, so we hand-steered for an hour in order to let it sort out its circuits. When we tried it again it worked fine — and did so all the way to St. Martin. That's a good thing, because the autopilot is our best crew-member. Anyway, it was great to make the passage without having to add to my existing 'fix-it' list.

Upon our arrival at St. Martin, and before we were able to get the anchor down, an unlit local Coast Guard inflatable roared up alongside us. Then a boarding party of four men and one woman, in full uniform and wearing big black boots, boarded us. I especially hated the big black boots, as I have a 'no shoes to be worn on the boat' policy in the tropics. Naturally they wanted to check my paperwork, at which point three of the others

started 'inspecting' my boat. One of the officers who was down below with me began asking about our safety equipment, and wanted to see whether my flares were current. Fortunately, when I prepared to sail north from St. Thomas last June, I was given several flares, still in date, but just barely. The officer and I had a laugh, as their expiration date was November 30th, which meant they'd be out of date the following morning!

The boarding party found everything to be in order on my boat. While they were fairly pleasant, and were done and gone in about half an hour, I nonetheless always find it stressful to have strangers go through my things. After they left, Robert and I proceeded to devour an entire ready-made lasanga that we'd started microwaving on our way into the bay. A short time later, we were crashed out in our bunks, sleep deprived after a somewhat stressful week of 'E-ticket' sailing.

But like I said, it feels sooooooo good to finally be back in warm water. Now I can continue to chip away at my project and repair lists. With the Atlantic Rally for Cruisers fleet having recently arrived in St. Lucia, I may sail down there to try to find some crew for the winter.

— marc 12/3/07

## **Snow Goose — Mapleleaf 50 Cherie Sogstie, Crew No Turkey On Turkey Day (Seattle)**

Having been anchored aboard the *Mapleleaf 50 Snow Goose* for a week at Isla Isabella, the 3.5-million-year-old bird sanctuary 75 miles north of Banderas Bay, the three of us — owner Mike McIntyre, my boyfriend Greg, and

***Isla Isabella is a bird sanctuary and, make no mistake, our many feathered friends take full advantage of its designation.***



CHERIE SOGSTIE



# CHANGES

I — decided that life aboard a boat revolves around activities and things that start with the letter 'S': sailing, snorkeling, snacking, and sunsets. I don't know why 'hiking' doesn't start with an 's', because we did a bunch of that, too.



CHERIE SOGSTIE

**The locals can be a little on the noisy side.**

While ashore the previous day and about to start a hike, we ended up having front-row seats at a big fight. It was a battle between iguanas. Two of the huge lizards sank their jagged teeth into each other's necks, then tried to rip through the other's scaly-skin. The winning iguana celebrated his victory by thrusting his head high to bask in the glory, and opened his mouth to reveal . . . a piece of the other iguana hanging from his lip. Ugh! The alpha iguana then gave me a look that said, "Don't mess with me, *chica*." I heeded his silent warning.

With that, Capt. Mike, Greg, and I took off walking to Crater Lake and the far side of the small island. Once on the other side, I jumped into the warm Pacific and bobbed up and down in the warm, clear surf. I wore a smile that had come from somewhere very deep inside. While I was cooling off, Greg explored the beach, and found a jumble of stinky lines intermixed with plastic bottles. By the smile on Greg's face, I could tell that he might as well have stumbled upon a treasure chest.

I was put on spider watch for the walk back to the other side of the island. My job was to lead our crew through the bush with a stick and displace any spiders blocking our path. Mike followed in the rear as the official Greg-untangler.

**Mexico is changing for the better. In the old days, the Isla Isabella beaches were lined with the carcasses of de-finned sharks.**



CHERIE SOGSTIE

Greg's new booty got caught on every other tree, and for some reason he seemed powerless to dislodge himself.

Believing that I was doing such a good job of keeping our path spider free, I slipped into complacency. I was soon punished for slacking off by walking face-first into a web containing a spider that, based on the damn thing's red spikes, must have had a feature role in *Arachnophobia*.

"Get that spider off me!" I screamed.

"The spider's not on you, it's on your hat," Greg replied, giving me that lame look all guys give their overreacting girlfriends.

"Get it off and we'll discuss the details later," I snipped.

I was vigilant for spiders the rest of the way back, which is why I suppose a bird was able to crap on me. Given the combination of the high humidity, the spooky spiders, and the foul-smelling bird shit streaked across my face and neck, you'd have thought that I'd be over that island. But Isla Isabella is such an incredible place that I thought it was worth enduring such small annoyances.

When we finished our hike by the fish camp, Greg presented the fisherman with his tangle of old line. They gave Greg the same kind of confused look I'd given him when he presented me with a lint-remover for Valentine's Day. I presume that Greg thought they'd be elated and would thrust freshly caught tuna in our hands. Alas, they just mumbled a confused, "*Gracias*". As we walked away, they probably shook their heads in bewilderment. I think I heard one of them softly say, "*Loco gringos*."

Tired from the hike, we nonetheless couldn't resist a quick snorkel. We were quickly rewarded with the sight of a spotted eagle ray gliding by. As if that wasn't enough, thousands of small fish swarmed beneath us, so tightly schooled that they obscured our view of the bottom.

A while later, we visited Neil Kaminer and the other folks on his Delaware-based Farr 58 *Tribute*. I was telling them a story of how we'd been given three red snapper by the local fishermen. Even though the fishermen didn't want anything in return, we handed them 20 pesos and a Costco-size bag of Halloween candy. Each fisherman took one small treat and then handed the bag back to us. "No, no," I said. "*Todo*



*es para ustedes.*" Their smiles betrayed a mixture of shock and delight, as they realized that all the candy was for them. Our smiles were just as big, for all three snapper were just for us.

As I was telling this story to the *Tribute* crew, one of them quietly interrupted me. "Excuse me," he said, "but there's a whale breaching behind you." Here's the thing — whales trump everything. They are a wake-everyone-up, interrupt-the-Pope kind of thing. You don't have to be polite when announcing a whale, because they are simply magnificent on every level. After all, you really have to marvel at an animal that has a penis that's bigger than my entire body.

We weren't the only ones anchored at Isla Isabella. Among the others were Wayne Hendryx, Carol Baggerly and Mary Forrest on the Brisbane-based Hughes 45 *Capricorn Cat*; John Forbes, Shirlee Smith, and Martha Marie on the Sceptre 41 *Solstice*; David Addleman and Heather Corsario on the Monterey-based Cal 36 *Eupsychia*; Glenn Burch and Rick Laska of the Seattle-based gaff-schooner *La Sirena*; and Deloris and Lynn Bolkar



COURTESY SNOW GOOSE

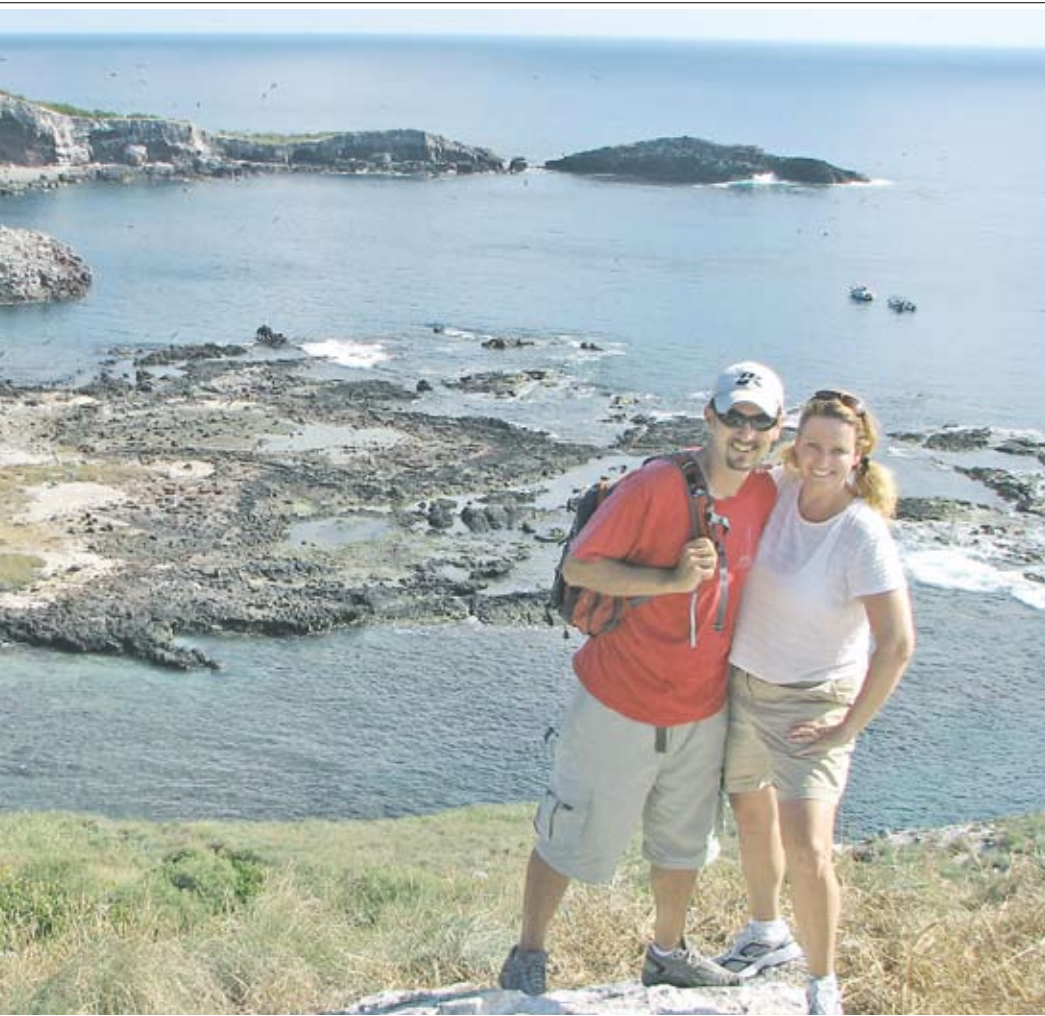

**Greg and Cherie high above the little bay at Isla Isabella. Out in the middle of nowhere, it was a great spot for Thanksgiving.**

and Steven and Jayce Flower of the big ferro ketch *Endless Summer*.

As it was Thanksgiving, we gathered for a feast that none of us will soon forget. A lot of people think you can't have Thanksgiving without a turkey. Well, we had fish and enchiladas, and fish and crab, and fish and fish, and more fish. We also had freshly baked bread, delicious brownies and other stuff, but the one thing we didn't have was turkey. Big deal.

At sunset, the crews — varying in age from 22-year-old Heather of *Eupsychia* to 70-year-old Lynn of *Endless Summer* — gathered on the bows and tramp of *Capricorn Cat* and, one by one, explained what they were most thankful for. Members of our group said they were thankful for everything from "finally" getting a watermaker to work to beating cancer. The meal and confessions brought us together as though we were family.

While our families back home may have been squabbling about who brought

the best pie, who forgot the mashed potatoes, and the suitability of somebody's fiancée, the crews of our six boats at Isla Isabella stretched our arms toward the star-studded sky and gave thanks for simply being alive in such a place.

— cherie 11/30/07

#### Cruise Notes:

"We made it! We finished the **Atlantic Rally for Cruisers** a little after dark on December 12, the 101st of 227 boats that completed the 2,700-mile crossing," exalted James Eaton of the Belvedere-based Hallberg-Rassy 43 **Blue Heron**, the only West Coast boat that participated. "Our last day was wild and fast, as the wind gusted to 40 knots. We completed the event without any malfunctions or breakage — which is remarkable given the conditions. But then just after crossing the finish line, we had a malfunction with the roller furling, and had to drop the genoa on deck! Once we tied up at Rodney Bay Marina, we just had to take long showers and have dinner in a restaurant. To be honest, the food wasn't any better than we'd had onboard — but at least we didn't have to do the dishes!

"Unfortunately, there was a tragedy in this year's ARC," continues Eaton, "as John Thompson, the owner of the Oyster 41 **Avocet**, was hit in the head by the boom during a jibe, failed to regain consciousness, and died in a Barbados Hospital. He'd been rushed there by a diverted cruise ship. *Avocet* is due to arrive today with the owner's son and other crew still onboard. What a tragedy. Yesterday we had lunch with the Dutch captain of **Scorpione dei Mari**, a beautiful Jongert 95 that was sailed by the owner and three guests, plus a professional crew of four, and crossed the finish line first. The captain, who has sailed around the world five times, reports that they destroyed about \$140,000 worth of sails on the crossing. Now that we've been in St. Lucia a bit, we've heard many stories of blown out sails, broken booms, and other damaged equipment, so we weren't overstating how rough the conditions were some of the time."

According to the ARC website, *Scorpione dei Mari* was actually the 21st boat to finish, and in a rather pedestrian 15 days, 11 hours. In fact, Eaton's time with *Blue Heron* — 17 days, 9 hours — was much better by comparison. The first boat to finish, in fact, was Bruce Dingwall's Southern Wind 80 **Matelot**, which crossed in 12 days plus a few minutes. The first of the 23 multihulls to finish was Julien Roudat's Lagoon 67 **Perle Noire**, which finished in 13 days, 1 hour, the fifth boat overall. That's quite a surprise given the fact that she's an older and heavier Lagoon. The last of the 227 boats to finish was Greg Feijen's Hallberg-Rassy 42 **Cadans**, which took

**Wyman Harris lands a 90-lb tuna during 'Blue Heron's' ARC. James Eaton will now head down to Trinidad for Carnival.**



BLUE HERON



# CHANGES

22 days, 8 hours. For an interesting look at what kinds of boats the Europeans are rallying across the Atlantic — the smallest of which was Henry Adams' **Ariel**, a 25-ft Nordic Folkboat — google 'Atlantic Rally for Cruisers'. It makes for interesting reading.

Earlier in *Changes*, we had a report on November's Virginia to British Virgin Islands **Caribbean 1500** from Cici Saylor of the East Coast-based Brewer 52 **Night Heron**. Now, for the rest of the story. This year's 18th annual fleet included 69 boats, perhaps a little smaller than it would have been had they not established a new minimum length for monohulls of 45 feet. According to organizer Steve Black, the winds were a little light all the way for the fastest boats, a little heavy all the way for the slowest boats, and just perfect all the way for the middle boats. "All things considered," he laughed, "good weather." Boats in the 1500 rally are allowed to motor and take a penalty, and it was interesting to note that, on the average, they motored about 75 hours. A few used the iron donk much more than that. Gil and Joy Smith's Con-



NIGHT HERON

*Having endured some wild weather in the Caribbean 1500, Cici of Two Harbors is now enjoying the wild colors of the Caribbean.*

necticut-based Farr 50 pilothouse **Joy For All** was the first boat to finish, and well she should have been, as they motored 121 of her 178 total hours (7 days, 11 hours). She corrected out poorly.

The fastest boat on corrected time was Alan Coren's New York-based Jeanneau 43DS **The Four C's**, which finished in just 214 hours (8 days, 22 hours), having motored just 34 hours, one of the lowest amounts in the fleet. Well done! Although they weren't in the same class, there was an interesting cruising catamaran battle between **Hammer**, Tom Robinson's Virginia-based high-tech, all carbon Gunboat 48 that rated -48, and Phil Gilihan's Virginia-based **Parallax**, one of the very few Corsair 3600 catamarans ever built, and which rated a much slower 78. Despite having motored 45 hours more, the inherently much faster *Hammer* only finished 15 hours in front of *Parallax*. It would be interesting to know what happened to the Gunboat, as one of the crew was Bill Biewenga, who in addition to being a great guy, is an excellent sailor — and an even better weather router.

"We recently heard from Kanji and Mieko Suehiro, who, like us, did the very first Baja Ha-Ha back in '94," write Rob and Mary Messenger, who did it with

## Puerto Lucia, the gate to the South Pacific

[www.puertolucia.com.ec](http://www.puertolucia.com.ec)

2900 miles to Marquesas Island

Galapagos At only 500 miles from Puerto Lucia

2.13° S 80.55° W

50-ton Travelift

Long and short term dry storage. Maintenance and provisioning.

Excellent climate year round, floating docks, fuel, laundry, Mediterranean-style moorings, Wi-Fi, Cruiser's Lounge electric and water hook-ups.

Ecuador has the Best Climate in the World

(Source: International Living, January 2005)

For Further information: 593-4-2783190 / 593-4-2206154 or email us: [marina@puertolucia.com.ec](mailto:marina@puertolucia.com.ec), [www.puertolucia.com.ec](http://www.puertolucia.com.ec)

the 45-ft **Maude I. Jones**. "Believe it or not, Kanji and Mieko have been cruising their Alameda-based Fuji 36 *Blue Fantasy* ever since! The boat is now in Malaysia. The couple decided that *Blue Fantasy* had gotten a little tired, so they just bought a Pacific Seacraft 37 in Annapolis, and are having it trucked to San Francisco Bay. Here's what they wrote to us recently:

"Our new boat is supposed to arrive this week, but meanwhile we've been spending an alarming amount of money at West Marine. Other than nautical stuff, Mieko is busy getting household stuff ready so that we can live aboard. But it's really a waste, since we have all this stuff on our other boat! Nonetheless, we just can't wait for our new-to-us boat to arrive. We're like kids waiting for Christmas. It's a feeling we haven't had for a long time, and I thank God that we're lucky enough to be experiencing it again."

"As for Rob and me," continues Mary, "we're on Chub Cay in the Bahamas working on boats for the foreseeable future.

Jimmy Buffet is on the island for two days with a couple of his buddies."

You know how bad whales' breath is? Well, take it from Jeffrey, Patti and Phoebe Critchfield of the Brickyard Cove-based Beneteau Oceanis 423 **Paxil**, there's something much worse. "While the whale was rubbing against our boat, he'd exhale out his blowhole, showering us with water and the stench of dead fish. But then he took a dump — it was much worse — and by far!"

"Rumors are flying around in the back of the pack of boats making their way down the coast of Baja that there are **anchoring fees** of up to \$160 at Cabo San Lucas," write Emmy Newbould and



***This just in — there's something worse than whale's breath. It's brown, it boils to the surface, and it smells much, much worse.***

Eric Wilbur of the Zephyr Cove, Nevada-based Flying Dutchman **Nataraja**, who are headed to the South Pacific for the second time with the same boat. "Now that sounds outrageously wrong, but for some reason wouldn't surprise us. We know the slip fees are way up there, and that there is a fee to pick up a mooring,

**Toll Free**  
1 866 365 25 62  
01152 646 155 41 06

info@marinapuertosalina.com



Marina  
Puerto Salina

**Marina Services**  
Power 220 / 110 volts  
Fresh water  
Security 24 hrs  
Cleaning  
Dock master  
Showers  
Dressing room  
Laundry  
Immigration

Shuttle to :  
Ensenada & US border  
Pump out  
Restaurant & Bar  
Yacht Club  
Dry Dock  
14 ft depth at low tide  
(channel access)

Lat. N 32° 3.28'  
Long. W 116° 53.20'  
Ensenada 27 NM south  
Tijuana 39 NM North

**New Slips Available 30 to 60 ft.**  
\$.55cts daily \$11.55 monthly \$9.35 & \$8.50 long term per ft per month.



# CHANGES

but to anchor?! We'd planned to stop at Cabo to check in, but if we had to pay to anchor, we'd probably continue on to La Paz. Can you tell us if this report is true?"

Like a lot of rumors on the cruising circuit, it's absolutely not true. Some of the developed ports in Mexico have APO port fees, but they're only about \$1 a day. And because the clearing procedures have been changed, there isn't always a way for officials to collect such fees in all ports.

Want affordable health care? Go cruising in Mexico. Gillian, who did the Ha-Ha this year with her husband John Foy on their Alameda-based Catalina 42 **Destiny**, developed a badly infected and inflamed elbow after sailing from Cabo to Punta Mita. Having gotten a look at it, we urged her to get treatment at a Puerto Vallarta hospital immediately. You never want those infections to get systemic. After a 'ranch doctor' attempt to drain the infection using a 'sterilized' hunting knife, Gillian took our advice the next morning. There are several good U.S.-style hospitals in Puerto Vallarta, and she chose Amerimed next to Marina



LATTUDE/RICHARD

*Gillian is as fun-loving as they come, but even she appreciates good medical care such as she received at Amerimed Hospital.*

Vallarta. To say that she was thrilled with the facility, the doctors, and the treatment — and to not have to wait for hours as in an American hospital — would be an understatement. The doctors took an

X-ray, drained the wound, tested to see what kind of infection it was, gave her antibiotics, and bandaged her up. The total cost? Just \$90, or about the price of an aspirin at a stateside hospital.

"We spent last winter in the Virgins, then sailed via Haiti — which was great — to the northwest Caribbean to get away from what we thought would be the majority of the hurricane threats," write Mike and Karen Riley of the Coronado-based Dickerson 41 ketch **Beausoleil**. "What a joke that strategy was! But if anyone is coming this way, they should put Isla Vache, Haiti, on their 'must visit' list. In return for \$20 worth of pencils and pens, plus a basketball, they filled our cockpit with veggies and fruit. Oh yeah, we fixed the town pump for them, too. But if you do visit, don't even think of clearing into Haiti. And don't worry, the locals will tell you where to hide on the other side of the island. We'll be leaving for the Canal soon, and it will be great to be back in the Pacific — and the land of *Latitude 38!*"

"In response to the editor's request," Mike continues, "I'll review our sailing

## SUNNY \* WARM \* FRIENDLY LOCH LOMOND MARINA IN SAN RAFAEL

**Completely Rebuilt Marina • Gas & Diesel Fuel Dock  
Free Pump Out Station • Modern Launch Ramp  
Guest Slips Available • Marine Mechanical Boat Repair  
Arena Marine Supply Store • Bobby's Fo'c's'le Cafe • Loch Lomond Market**

**110 Loch Lomond Drive, San Rafael, CA 94901**

**Phone: (415) 454-7228 • Fax: (415) 454-6154**

**www.lochlomondmarina.com**

**Harbor Master – Pat Lopez • pat@lochlomondmarina.com**





history, as I realize that it's been a few years. My first circumnavigation was aboard my engineless Columbia 24 **Tola**. Sounds radical, doesn't it? It wasn't. I lowered the cabintop 15 inches — it was the Weekender model — before I left Coronado, then extended the cabin into the cockpit — an easy modification — to increase the room down below and reduce the volume of water the cockpit could hold in the event of a knockdown. I would later add a four-foot-long bowsprit in Sri Lanka. I met Karen in Rabual, Papua New Guinea, where I was hiding from tropical cyclones and she was teaching school. We fell in love, married in Australia's Northern Territories, sailed across the Indian Ocean, went up the Red Sea and through the Suez Canal, and had our son, Falcon, in Malta. We continued across the Atlantic and Caribbean, and came up through the Sea of Cortez, where we briefly met the Wanderer/Publisher of *Latitude* at Sea of Cortez Sailing Week. That was the year he was on his Olson 30 **Little O**, wrecked his back, and had to be flown home on a stretcher in the back of an Aero Mexico

plane. We eventually sold *Tola* in Hawaii and, after nine months of serious hard work, purchased our Dickerson 41 **Beausoleil**. We took our new boat around the world via Panama and the Cape, three years of which we spent 'em-bayed' on the Eastern Shore of Maryland while Falcon — how time flies — completed high school. During that time Karen worked for Hinckley Yachts and I drove a car ferry. Falcon is now attending college in San Diego and, as I mentioned, we're on our way to the Pacific. We plan to head up to the Sea of Cortez. We're still on *Beau* and very happy with her, even after being rammed by a whale, enduring the eyes of several Category 5 hurricanes, and all the normal wear and tear. In the meantime, life is good out here, but we need more parties. So our



'Bronco', as seen going the in 'right' direction — meaning down to Mexico — during the '95 Ha-Ha. Nels can make that ketch go!

advice to everyone is, drop those dock lines and come and join us!

We're hoping to see the Rileys at **Sea of Cortez Sailing Week** once again, as we've reviving that in early April. See *Sightings* for details. And by the way, we don't care what Mike says, we still think circumnavigating with a Columbia 24 Weekender, modified or not, is pretty radical.

"Three crew and I departed El Cid

## OPEQUIMAR

MARINE CENTER    CENTRO MARINO

**88-ton (max)  
Travelift!**  
Length to 100'  
Width to 23'

Puerto Vallarta, Jalisco, Mexico  
Paseo de la Marina Sur #214 • Marina Vallarta, 48354  
Tel: 011 52 (322) 221 1800    Fax: 011 52 (322) 221 1978  
email: [info@opequimar.com](mailto:info@opequimar.com)

Visit Our  
Yacht Club!

Opequimar Yacht Club

First Class • Full Service

On site dining, Internet, socials

BOAT SALES  
NEW & USED BROKERAGE

www.opequimar.com

We make boating more fun!

A KONGSBERG Company

marine paint

Come to Mexico,  
Enjoy the Mexican Riviera,  
Repair your boat at  
**OPEQUIMAR**



# CHANGES

Marina in Mazatlan on December 1 to bring my Out-Island 41 **Bronco** back to Northern California," writes Nels Tober-son. "The best sailing we had of the whole trip was the first night and day — we even got to use the spinnaker for about eight hours. It got pretty rough the night before we arrived in Cabo, and that was it for Christina, who got off. She thought we'd be doing a nice daysail each day and then be in port at night. After taking on fuel and water, the three of us remaining set out for 420-mile-distant Turtle Bay. We had a few hours of wind and waves, but it was mostly a good motorboat trip. The crew wanted to spend some time in Turtle Bay, so we did — four days. With the cell phone and internet reception, we got enough good weather information to make the next 360-mile leg to San Diego. We left Turtle Bay and, against my wishes, travelled up the back side of Cedros, arriving at the north end in the afternoon. The little anchorage had several mooring buoys and one *panga*. We spent a rolly night there. But we didn't get bad weather until 100 miles from San Diego, when the wind and waves on



LATITUDE/ANDY

**On an impulse, Nels decided to shoulder the entire load of delivering 'Bronco' the last 444 miles home from Mazatlan.**

the nose slowed us and gave us a rough ride. With one of the crew not able to recover from a cold, I spent a night at the San Diego Police Dock, during which time I noticed that there was a weather

window to San Francisco. I made the scary decision to try do the last 444 miles to San Francisco by myself. I was to have two anxious periods. The first was halfway from the Channel Islands to Conception about dark, when the wind came up on the nose. I had a long and difficult rounding of Conception, but was rewarded with good weather passing Pt. Sur. Then, while I was west of Monterey Bay in the middle of the night, the wind came up to 25 knots and gusted to 40. This was isolated wind that came without warning or reason. By morning the wind was light again, but there was still a large swell. The rest of the passage to the Golden Gate was quite good, and I made it to my berth before the most recent storm hit. I only had a few problems with *Bronco*. Right after I left El Cid, the AC generator would shut down right after it was started because it was getting hot. This was potentially serious, as *Bronco* depends on AC power. I will never go to sea again without a backup inverter. After several hours and trying many fixes, we got it running fine again and

## Your Boatyard in the Heart of Paradise



Large, fenced, secure dry storage area

**Tahiti Customs policy has changed!**  
Foreign Flag vessels can stay on dry storage in our yard for up to 12 months out of 24.



A Subsidiary of  
The Moorings Yacht Charter, Ltd.

### Our Services |

#### HAULOUT

- Marine Travelift 25 tons
- Marine railway 120 tons
- Storage in adjustable steel cradles
- Fenced Yard

#### PAINTING

- Topsides, hull, bottom, varnish
- Brush, roller, spray

#### MECHANICAL WORK

- Inboard, outboard, diesel, gas
- All brands

#### REPAIRS

- Electrical repairs
- Refrigeration installation & repair
- Fiberglass & woodwork
- Welding, steel, stainless, aluminum

#### SAIL LOFT

- Sail repairs, biminis, dodgers, covers

#### STORE

- International, Pettit, Epiglass, Devoe
- Spares
- Fill U.S. gas cylinders

#### DO-IT-YOURSELFERS WELCOME!

BoatUS Cooperating Marina



Professional boatyard in the heart of Paradise

Raiatea Carenage will make sure  
paradise is everything you expected.

Call, write, or sail in . . . we're here to serve you.

B.P. 1111 Uturoa Raiatea 98 735 Polynésie Française

Tel: (689) 600-545 ~ Fax: (689) 600-546 ~ VHF 68

Web site: <http://www.raiatea.com/carenage> ~ email: [raiatacarenage@mail.pf](mailto:raiatacarenage@mail.pf)

it still runs great. We just don't know why. Then the main engine couldn't run on fuel from the main tank — meaning there were 60 gallons we couldn't use.

Then I discovered an air leak in the suction side of the tank. I replaced the hose and the problem was solved. I also had to replace a galley light. I'm happy that *Bronco* and I are home, but I'm very tired. Nonetheless, my 'house' is moving, so I need to go out in the rain and tighten the docklines."

"Debby and I just got back from a land trip to Zihua, and can report that everything is still grand," writes Tim Tunks of the Marina del Rey-based Islander 37 *Scallywag*. "We stayed at the Sotovento Hotel, where some 15 years ago, *Latitude's* Ocean 71 *Big O* spent an entire spring moored in their 'front yard'. From our vantage point we had a good view of arriving cruisers. Two I recognized were *Neriad*, a Hans Christian 43 ketch that had been our berth neighbor in La Paz one summer about a



*Nothing is for certain, but it appears that protests may have spelled doom for the nutty idea of ruining Zihau Bay with a cruise ship pier.*

dozen years ago, and a junk-rigged Colvin schooner, sistership of the beautiful *Joss* and *Migrant*. One summer, John Kelly, who is now cruising the South Pacific aboard his Seattle-based Sirena 38 *Hawkeye*, and I helped the owner, a retired dentist named Bill, sail *Migrant* from Tonga to Fiji. Bill and I continued to cruise Fiji for another week or two where, in return for his pulling a tooth or two at small family villages, we were treated like kings. Oh, the great memories! The great news in Zihua is that there's a big sign that reads, 'No', to the construction of a cruise ship pier that has been proposed to extend from the fisherman's

beach near the *zocalo* far out into the center of the bay, which would ruin the very thing that makes Zihua so appealing. It's hard to tell, but the protests may have been successful.

Also reporting from Zihua is Jim Carpenter of *Rick's*, which is the cruiser center in Zihua. "Although it's early December, about 10 cruising boats have already trickled in," he writes, "with another 30 on their way. A bunch of them were held up by high winds in the Sea of Cortez, so maybe next year's group will learn to head south a little earlier. Anyway, the weather here has been awesome, and we're ready for the cruisers. Nathaniel, the dinghy valet, is back on duty for the season, offering his much appreciated services. Our wifi is up and running, but we had to impose restrictions yesterday because so many people with wifi phones were locking it up. Cruise ships are coming in at the pace of two a week, saving the butts of local merchants until the cruisers arrive in force. Naturally all the locals have been

## YOUR SECRET PARADISE...



Located in a beautiful sheltered lagoon on the north Pacific coast of Nicaragua, Marina Puerta del Sol is your premier cruising destination in Central America

- Onsite Immigrations & Customs
- Full service restaurant and bar
- 24 hour security patrol
- Internet & Fax/copy service
- Yacht club with showers and laundry



- 140 foot fuel dock - diesel/gasoline
- Well marked channel
- 40 slips with water, power and cable TV
- Two pools, oceanside and marina
- Tennis, surfing, fishing, horseback riding
- Luxurious hotel with 19 executive suites



# Marina Puerta del Sol

Aserradores, Nicaragua • 011[from US and Canada] 505-883-0781 mpuestadelsol@yahoo.com • www.marinapuestadelsol.com • USA 408-588-0017

...IN BEAUTIFUL NICARAGUA



# CHANGES

up in arms about the proposed cruise ship pier, and I suspect the government won't go against their wishes. As soon as a few more cruisers arrive, we'll put together a committee for SailFest and get started on that."

Let's make sure that nobody cruising south of the border forgets that **Zihua SailFest** is the big cruiser fundraiser in Mexico, and that this year's 7th annual SailFest will be from January 29th through February 3rd. Last year cruisers raised an astonishing \$47,000, which, thanks to matching funds, climbed to almost \$95,000, most of which went to the construction of the *Nueva Creaciones School* and 12 other local school projects. In addition to cruisers doing hands-on work at the schools, raising money, and enjoying many social activities, there's also a fun pursuit race. Don't miss it. Zihua SailFest depends on an almost entirely new group of cruiser volunteers each year, so if this is your year, please don't forget to step up to the plate. Once you see what you've helped do, you'll never forget it. For more information and photos from previous years, visit [www.zihuasailfest.com](http://www.zihuasailfest.com).



LATITUDE/RICHARD

*This is the weather center report aboard 'Profligate' at dawn on December 8 at Punta Mita, Mexico. Perrrrrrfect!*

[zihuasailfest.com](http://zihuasailfest.com).

What a difference 300 miles makes — even in Mexico during the winter. With other commitments preventing Bill Lilly from being able to bring his Newport

Beach-based Lagoon 470 **Moontide** down to Banderas Bay for the Pirates for Pupil's Banderas Bay Blast, he reported that the high temperature in La Paz on a day in early December was just 60 degrees. Northerners can really drop the temperature everywhere in the Sea of Cortez. Meanwhile, down in Banderas Bay, it had consistently been 85 degrees during the day and 75 at night — meaning no sheets were necessary. The evening temps on Banderas Bay dropped to requiring a light blanket at night by mid December, but the days were still as warm as anybody could want.

"We're still having a great time 'commuter cruising' in Mexico," report '04 Ha-Ha vets Jeannette Heulin and Anh Bui of the Emeryville-based Bristol 32 **Con Te Partiro**. "We're in Nuevo Vallarta now, having spent two years enjoying the Sea of Cortez. But now we have to wait for our next vacation to continue further south. The problem with commuter cruising, of course, is finding places to leave our boat for two to three months at a time. We started this season by leaving



## OWL HARBOR MARINA

### THE FRIENDLY MARINA

**HOME OF  
ANDREAS COVE  
YACHT CLUB**  
Limited Time Only—  
**\$100 Memberships**  
*Call for details*

- 30'-50' deep draft berths @\$5.00 per foot
- Dry and open storage
- Extra wide berths for multihulls
- Home of Club Rio Sailing School
- Robert A. Viel, Certified Marine Surveyor

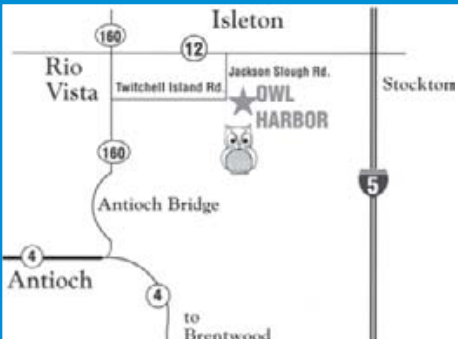

**'CANVAS BY THE LOOP'**

On-site canvas & repair shop

- SAIL - Alterations & Repair
- CANVAS - New & Repairs
- SAILBOAT RIGGING
- HARDWARE INSTALLATIONS
- 12-VOLT REPAIR & INSTALLATION
- FAST TURNAROUND ON REPAIRS

LOCATED ON SEVEN MILE SLOUGH  
OFF THE SAN JOAQUIN RIVER

HARBORMASTER: SHAWN PASSERI

(916) 777-6055

email: [shawn@owlharbor.com](mailto:shawn@owlharbor.com)  
[www.owlharbormarina.com](http://www.owlharbormarina.com)

1550 W. TWICHELL ISLAND RD.  
ISLETON, CA 95641

Mazatlan on October 28th, which is a bit early, but we wanted to beat the Ha-Ha crowd to Banderas Bay to get a berth. We had an idyllic two-week sail down. We spent three days at Isla Isabella, and also visited San Blas, Punta Mita, and La Cruz before settling in at Nuevo. We never saw another boat the entire way. Did you know that there is a French restaurant in La Cruz that, if you ask, will prepare a proper steak tartare? It's Le Rêve — which means 'The Dream' in French — Restaurant, Café and Concert Venue at 66 Coral. It was formerly the Hikuri Cafe. And as we're French, we're glad to see those crazy Frenchmen are back at chasing the singlehanded and crewed around-the-world records once again."

Neither fish nor fowl. Ray Durkee of the Alameda-based Tartan 37 **Velera** got a job as a harbormaster at Castine, Maine, and had two years to get there with his boat. "The trip was okay," he writes, "but I didn't really have the right attitude or schedule. Since I'd given myself two seasons to get from San Francisco to

Maine, mine was a cross between a cruise and a delivery. And as you surely know, those are different mind-sets that are in complete conflict with each other. As a result, every time I'd come to a really great place — Chacala, Mexico, the beaches near Huatulco, Drakes Bay in Costa Rica, the Perlas and San Blas in Mexico — I'd seem to get a really great weather window and would have to get some miles behind me. It's a baaaaad concept for cruising. Anyway, the highpoint was a month I spent in the San Blas Islands — even though I didn't have a watermaker! But it was a great experience, and I want to thank *Latitude* for its part in inspiring it. I've been reading the magazine since you started it as



**Although only you can make the decision, it may be in your best interest to utilize the expertise of Polynesia Yacht Services.**

sneakaboards at Clipper Yacht Harbor in Slezalito. Jimmy Buffett's sailboat was in our harbor here at Castine again for the summer, but I never did see him. But Eric Clapton is a regular. The swimming sucks here because the water is so cold, but with the possible exception of the San Blas Islands, we have the best cruising that I've ever seen."

In the past, we've gotten good reports about **Polynesia Yacht Services**, and a

## SVENDSEN'S

# JANUARY FURLER SPECIAL

Buy select Harken and Schaefer furlers  
at **10% OFF LIST** and receive

**FREE ASSEMBLY  
AND INSTALLATION**

by Svendsen's professional riggers.

Expires 1/31/2008



**THE BAY AREA'S ONE-STOP LOCATION FOR  
MARINE PRODUCTS AND BOAT REPAIR!**

Located in the Alameda Marina • 1851 Clement Avenue • Alameda, CA 94501

BOAT YARD: **510.522.2886** • CHANDLERY: **510.521.8454**

**www.svendsens.com**



# CHANGES

lot of cruisers heading toward French Polynesia wonder if their fees — which aren't cheap — aren't nonetheless cost effective. For their fee, PYS has someone meet your boat in the Marquesas with all the paperwork — including the visas and port captain papers. That's a very nice convenience. In addition, those who use the company's services don't have to post the bond, which for some boats can be thousands of dollars. And you always lose money on that exchange. But perhaps the biggest money-saver is being able to buy fuel at \$3.50/gal. as opposed to the regular price of \$7/gal. If you're going to be topping off with 150 gallons, that's a \$300 savings right there. For more details — and mind you, *Latitude* is not necessarily recommending them — google 'Polynesia Yacht Services'.

Mike Harker had hoped to make it around the world in time with his Hunter Mariner 49 **Wanderlust 3** to attend the New Year's Eve festivities at St. Barth, French West Indies. Alas, the determined sailor, whose Lake Arrowhead home burned in the recent wildfires, ended up running behind schedule and won't



COURTESY WANDERLUST 3

*With Mike Harker having now turned 60, we suppose we can cut him a little slack for taking a little more than 11 months to go around.*

make it in time. Nonetheless, the daughters of some local friends threw him a little party for his 60th birthday just a few days before setting sail up the Atlantic. Harker should finish his circumnavi-

gation, much of it singlehanded, by early February, which means his boat will be displayed at the Miami Boat Show.

"The Roatan YC in Roatan, Honduras, is decent, the docks are all right, and the staff is friendly," reports former-Alameda-then-St. Martin resident Jerry Blakeslee of the St. Maarten, Netherland Antilles-based NAB 38 **Islomania**. "The place is currently undergoing a change in ownership, so the bar and restaurant aren't open. But there are lots of fringe benefits that come with the \$250/month berths — including cable tv, free wireless internet, a swimming pool, a pool table, and free ice, water, and electricity. They do, however, charge extra for electricity if you have an air-conditioner. Unlike most of the Caribbean, they have full-length docks, not the Med-moor arrangements you see at most places. Space is limited, so contact them via email well in advance if you're looking for a slip. The marina is also conveniently located near the largest super mercado on the island, as well as banking. About the only downside is that the water in the marina is sometimes

service &  
quality  
at the best  
price

75 ton travel lift  
Paint, carpentry & blister repair  
S.S. & aluminum mig & tig welding  
Mechanical & structural work  
Full service marina  
Short & long term rentals

[bajanaival.com](http://bajanaival.com)

Ensenada, México  
Ph 011-52-646-174-0020  
Fx 011-52-646-174-0028

**BAJANAIVAL**  
**Boatyard & Marina**

**Peaceful Southern San Diego Bay**

Slips Available Various Sites

See us at the SAN DIEGO BOAT SHOW Jan. 3-6

**HOME OF CHULA VISTA MARINA**

552 slips with complete amenities from private dock boxes to pool and jacuzzi to ample free parking.

**Come feel the South Bay difference.**

Permanent or temporary berths available.

**(619) 691-1860**

Dockmaster's office open 7 days a week

[boatslips@cvmarina.com](mailto:boatslips@cvmarina.com)  
[www.chulavistamarina.com](http://www.chulavistamarina.com)

dirty with oil, thanks to the fishing and other commercial boats in the general area. After another 10 days here, Cay Hickson and I will be off to Guatemala's Rio Dulce for a haulout, bottom paint job and some other minor repairs."

"I'm writing this on my 61st birthday, but January 4 will be my 27th **Alcoholics Anonymous birthday**," writes a reader from Mexico. "My demographic is all over Mexico, both cruising and fueling the real estate boom. Most of these people are truly responsible with alcohol, nonetheless, booze has been a problem for a certain percentage of people since the beginning of time. I'd like to let everyone know that there are AA meetings where English is spoken all over Mexico. For example, they have them at the El Patio restaurant in Melaque on Wednesdays and Sundays at 5 p.m., at the Rincon restaurant in La Manzanilla on Fridays at 6 p.m., and many, many other places. Just ask around. The meetings are well attended, both by newcomers and people with years of sobriety. I've been to AA meetings all over the world,

and these are some of the best."

It's been our observation that the number of cruisers with drinking problems in Mexico has dropped dramatically in the last 15 years or so. Nonetheless, it can still be a real problem for some, as it's easy for drinking to find too great a role in the cruising life. Just to be on the safe side, we suggest that all drinkers take a two-week or so break from alcohol from time to time, just to make sure it's not getting away from you. As for those of you who attend AA meetings, we have the highest respect for you.

The last photo in this month's **Changes** is of something we hate to see — the apparent death throes of a vessel. "We've seen the converted tug **Justine** doing charters down here in La Paz for the last year," writes John van Strien of



*Could this be the sad and ignominious end to 'Justine', which has been chartering in the Sea of Cortez for the last year or so?*

the Edmonton-based Christensen 55 **Western Grace**, "but as you can see, as of early November she was in big trouble. Many locals think she'll never float again. Apparently she'd become stranded close to shore a few weeks before during a very low tide, which made her list. Then she filled with water on the incoming, most likely as a result of a very leaky hull above the waterline. She's been flooded ever since."

## A PROTECTED HARBOR A SCENIC SETTING WITH EASY ACCESS TO THE BEST SAILING IN THE WORLD!



*Call for guest  
berths or reserve  
space for your  
club cruise!*

**Brand new  
docks - 40' to 50'  
for qualified  
recreational  
boaters!**

### Berkeley Marina

201 University Ave., Berkeley, CA 94710

**(510) 981-6740**

Fax (510) 981-6745

[www.ci.berkeley.ca.us/marina](http://www.ci.berkeley.ca.us/marina)

Fuel Dock • Boat Yard • Chandlery • Yacht Club  
Sailing Club • Four Terrific Restaurants



Please read before submitting ad

# CLASSIFIEDS

- 1. Write your ad. Describe what you're selling. Indicate category. Don't forget price and contact info.** Be neat. We aren't responsible for errors due to illegible writing or unclear meaning. We make final placement determination.
- 2. Count the words. Anything with a space before and after counts as one word (eg, phone number, email address, price).** We'll spell-check, edit and abbreviate, as necessary.
- 3. Mail your ad. Enclose check or money order, or deliver to our office with cash, or ...**

Post your ad safely online with Visa, MasterCard or AmEx at: [www.latitude38.com](http://www.latitude38.com)

## Personal Ads

1-40 Words: \$40  
 41-80 Words: \$65  
 81-120 Words: \$90  
 Photo: B&W \$20  
 Photo: Color \$30  
 • Personal Advertising Only •  
 No Business/promotional ads except Non-Profit, Job/Biz Op.

## Business Ads

\$70 for 40 Words Max  
 All promotional advertising  
 1 boat per broker per issue  
 Camera-ready art OK  
 No photos/reversals  
 No Extra Bold type  
 Not to exceed 12 pt font  
 Artwork subject to editor approval.

## 'Trying to Locate' Ads

Searching for People: \$10 for 20 Words Max  
 All ads will be set to fit Latitude 38 standard.  
 Re-Run Ads: Same price, Same deadline.

Mail (or bring) to: **Latitude 38**  
 Attn: Classified Dept  
 15 Locust Ave, Mill Valley, CA 94941  
 Questions?: (415) 383-8200, ext 104 • [class@latitude38.com](mailto:class@latitude38.com)

## DEADLINE

is always the

**18th at 5 pm**

of the month prior to publication.

Due to our short lead time, deadlines are *very strict* and include weekends & holidays.

- No ads without payments
- No billing arrangements
- No ads accepted by phone or fax
- No verification of receipt
- We reserve the right to refuse poor quality photos or illegible ads.

## DINGHIES, LIFERAFTS AND ROWBOATS

**1997 LASER, SLI-MANUFACTURED.** Clean condition, good rig, standard and radial, Seitec dolly. Can be seen at Richmond Yacht Club by appointment. \$2,500. Also 1976 model but still good sailer for \$1,200. Email: [chrisg26.2@gmail.com](mailto:chrisg26.2@gmail.com).

**PORTA-BOTE, 10.5-FT** folding boat and 5-hp Nissan 2-stroke outboard. Included: Motor gas tank, life jackets, anchor, Porta-dolly transporter and oars. Boat/motor purchased new in 1995. Both in good shape. Ready to go for \$800. Questions please call (510) 441-1240; if machine answers please leave message. For information and pictures about Porta-Bote visit <<http://www.porta-bote.com/>>

**310 ZODIAC RIB WITH COVER.** 15-hp Yamaha, very low hours. Comes with trailer. \$3,600/obo for all. (415) 383-1985.

**FATTY KNEES, LYLE HESS DESIGN.** 7-ft sailing dinghy, \$700. 9-ft sailing dinghy, \$1,100. Glass, oars/locks, both with sailing gear. 7-footer, call (415) 479-1832. 9-footer, call (415) 924-2232.

## 24 FEET & UNDER

**SANTANA 22.** Well cared for, nice interior, spinnaker, depth. Well organized by competent owner. Bottom job just done at Berkeley Marine Center 10/07. \$3,000 with Honda 2BF or \$2,500 with Johnson 6 hp. (415) 505-7011.



**SCHOCK 23, 1987.** Wing keel. New FB main, 130 North genoa, asymmetrical spin, tillerpilot, Garmin 168, Yamaha 9.9 electric start, pop-top, trailer with extension tongue. All great condition. Much more. \$10,500. Call (503) 873-5607 or (503) 559-3661.

## 25 TO 28 FEET

**PEARSON 26, 1973.** The perfect boat for singlehanded sailing. Well equipped and well built. Harken roller furling, Lewmar self-tailing winches, 5-year-old North sails, Doyle StackPack makes it a snap to stow the sails, 9.9-hp 4-stroke Nissan, cockpit-mounted throttle controls for added safety and visibility. The Pearson 26 has an excellent reputation for stability in heavy weather. A pleasure to sail on your own or with a crew. A very nice boat for a nice low price: \$4,000. Loch Lomond Marina in San Rafael. See pictures at: <<http://www.flickr.com/photos/21773152@N07/sets/>> Call Jacob (415) 789-1042 or email: [jacob53@yahoo.com](mailto:jacob53@yahoo.com).



**RANGER 26, 1974.** Great condition. Only \$4,900/obo. Santa Cruz, CA, Lower Harbor. 9.5-hp Johnson outboard motor, runs good. Sails: Standard main, 120 roller furling, storm jib, depthsounder, VHS. Must see this well-kept beauty. Call Bruce (831) 476-4259.



**SKOL, ERICSON 27 FOR SALE.** Good looking, great sailing boat. Atomic 4 that purrs. Everything in working order. Mainsail, jib, spinnaker, replacements. Built 1974, winner 1982 Regional Championship; could easily capture a winter series. \$7,500. (415) 460-1106.

**SANTA CRUZ 27** for sale or trade for ? Fantastic Bay boat. Complete sail inventory including main, 3 jibs, spinnaker, blooper. Recent in-water survey. No outboard. Asking \$7,500. Photos/info/survey: <[www.spinnaker-sailing.com/SC27forsale.htm](http://www.spinnaker-sailing.com/SC27forsale.htm)> (415) 543-7333.

**CATALINA 27, 1978.** Custom teak interior, dinette model, 2-burner alcohol stove, 110v refrigerator, phone/cable and 110vac inlets. Atomic 4 engine, runs great, includes freshwater flush. Battery charge system, VHF radio, 2 anchors, rain roof, sail cover and much more. \$9,500. (415) 331-2044.

**SANTANA 525, 1978.** Two-part poly paint, Teflon bottom. New mainsail, new 85, new interior, new mainrig/traveler/boomkicker/lazyjacks. New 6-hp Nissan, great single-axle trailer. Dry sail slot at Svendsens, Alameda. Ready for 10 years of service. \$7,000. (928) 208-3822.

**CATALINA 27, 1976.** Very tidy, 2 outboards: 15-hp Mercury recently serviced and 4-hp Suzuki. Furling jib, good sails, recent windows/keel bolts/marine battery. Surveyed May 2007. Treasure Island berth. Ready to race or simply for leisure. \$8,000. (510) 299-2001 or [gslisbury@xyratex.com](mailto:gslisbury@xyratex.com).

**CONTESSA 26 FG FULL KEEL** world cruiser. Custom installed 4-stroke Honda 12-hp inboard saildrive. New heavy-duty cruising sails and running rigging. Near-new standing rigging. Trans Pac? \$9,200. Call (510) 499-9211.



**2004 MacGREGOR 26M** power sailer. Excellent condition, fully loaded, stored in dry dock for two years. Approved 70-hp 4-stroke outboard, sleeps 6. \$25,990. Contact Dan or Jeff at *Arena* in Loch Lomond (415) 456-2644.

**Jack D. Scullion**  
 Yacht Services  
[jdsyachts@att.net](mailto:jdsyachts@att.net)  
 (510) 919-0001

Rigging  
 Electronics  
 Troubleshooting  
 Electrical Installations

Online and home study courses in all areas of marine navigation and weather

★ ★ ★ ★  
**STARPATH**  
 School of Navigation

More than 25,000 students since 1977

(800) 955-8328 • [www.starpath.com](http://www.starpath.com)



**MARINE SURVEYS by Captain Alan Hugenot**  
 Naval Architect • Yacht Delivery Skipper  
 Accredited Marine Surveyor (SAMS)  
 ••• Bay or Delta • No Travel Charges •••  
 All major credit cards accepted • (415) 531-6172

**CHART SAVINGS UP TO 75%**  
**HIGH DEFINITION PRINTS • 256 INCREDIBLE SHADES!**  
 Worldwide • Sample Chart \$7.95 • Affordable E-Chart back-ups  
 Bellingham Chart Printers Division, TIDES END LTD., PO Box 397L, Shaw Island, WA 98286  
 800-643-3900 • fax: 360-468-3939 • [www.tidesend.com](http://www.tidesend.com) • [sales@tidesend.com](mailto:sales@tidesend.com)



**MERIT 25.** Race and cruise ready. Two new mains, new 70% and 100% jibs, spinnaker, screecher. Hauled 3/07. Jiffy reefing, Nissan 3.5 hp, new cushions. \$6,500/obo. John (510) 750-2258.

## 29 TO 31 FEET

**RAWSON 30, 1981.** Unbelievable deal. We equipped her, sailed down to Mexico, and now we must sell. She is a spacious, strongly built, bluewater cruiser with GPS, watermaker, fridge, Monitor windvane and much more. Sitting in LaPaz, waiting to go. We have a new baby or we'd still be sailing. Paid \$40,000. Sell for \$20,000/firm. Call Jay (604) 617-1436.

**PACIFIC SEACRAFT MARIAH 31, 1979.** Factory-finished liveaboard cruiser, double Pullman berth, no sleeping in the forepeak. Major refit in 2000, extremely well found, lovingly maintained. Lying Mazatlan. \$65,000/obo. For specs and photos email: jhallorion@netzero.net.



**NONSUCH 30, 1982 CLASSIC.** Hard dodger, autopilot, anchor windlass, all chain rode. 4-cyl Westerbeke with V-drive, 2,000 hours. Force 10 propane cabin heater, Paloma demand water heater. New aluminum propane tanks with crossover. Electric main halyard windlass. Propane stove with oven. New Sunbrella cabin cushions, vinyl cockpit cushions, interior refinished. Lee cloths, all berths and jacklines, new sail cover. Located Richmond, CA. \$49,000. (925) 934-1580 or dhwheeler94598@hotmail.com.

**OLSON 30, 1983. FAMILY HOUR.** Turn-key boat. Stiff hull and all class-approved stiffeners. Clean. Double spreader rig. 22 bags of sails. Keel and rudder faired. Numerous upgrades. Trailer. One of the most winning Olsons on Bay. \$20,000/obo. (925) 934-6926.

**NEWPORT 30, 1985.** New mainsail, wheel steering, Universal diesel, Harken furling, new upholstery. Solid bay boat. Needs some TLC. \$14,000. Stephen (775) 782-2584.

**IRWIN 30 CITATION SLOOP, 1977.** Yanmar engine, new sails, roller furling, many more recent upgrades. Possible Sausalito berth. New bottom paint 10/2/07. Asking 10,500/obo. Call (415) 302-1960 or email: jim.gagnon@comcast.net.

**CAL 31, 1980.** New mast, standing and running rigging, full batten main, 5 headsails, spinnaker, wheel steering, 16-hp Universal diesel, feathering propeller, propane stove, pressure water, bottom painted 5/2007, VHF, depth, speed. Asking \$19,900. Ventura. Call (805) 701-5622 or email: mike@vhby.com.



**WILLARD 30, 1976.** Crealock world cruiser, Baja Ha-Ha vet. Perkins 4-108, full keel, great liveaboard, Raymarine autopilot, radar/chartplotter, Lofrans windlass, lots more gear. Biggest 30-footer you'll ever see. \$34,500. <http://willard30.blogspot.com> (408) 887-3103.

## 32 TO 35 FEET

**PEARSON 32 RACER/CRUISER, 1979.** \$22,000. Original M-15 Universal diesel. Gear (about 1995): Autopilot, digital depthfinder and gauge, gennaker, Harken furler, Navtek backstay adjuster, Quik Vang, radar, WM Loran-C, 25w marine radio. New: 19-gal aluminum fuel tank, batteries, electric fuel pump. Documentation: All original manuals, 1995 surveys, log, maintenance, add-ons, diving, haul records since my 1995 purchase. Location: Alameda. Suggestion: Please see Aug. 2007 *Practical Sailor* before calling. Fast, easily singlehanded cruising boat for couple; not a motel. (510) 525-2754.



**EXPRESS 34.** *Locomotion* is seriously for sale. Your chance to own one of Carl's best designs. Successful Puget Sound race record. Many upgrades prior to 2006 Pacific Cup. New rod, sails, charging system. Spec sheet available. Asking \$73,500. Call (425) 765-2456 or ebmorgan50@yahoo.com.

**O'DAY 34, 1984.** Well maintained. Great Bay and coastal cruiser. Yanmar 3YM30, 500 hours. Roller furling, wheel steering, Autohelm, radar, GPS, VHF, WHAM, hot and cold water, LP stove. \$31,000. (916) 920-4423.

**COLUMBIA 34 Mk II, 1972.** Solid boat, good condition. In Moss Landing Harbor, a hidden gem in Monterey Bay. Upwind slip in highly desired North Harbor, near Elkhorn Yacht Club. Excellent, very roomy interior as 'cabin-in-the-mountain' or for liveaboard. Fully functional: Radar, tiller/pilot, new VHF and stereo, 2 water tanks, brand new holding tank, refrigerator, hot water (AC). Roller furling jib, dodger, depthsounder, 2 anchors. \$22,500. Contact: mistral\_x@msn.com or (408) 375-1998.

**C&C 35.5 Mk II, 1974.** Restored Yanmar GM30F, 320 hours. 6 Lewmar ST winches, full sails, new asymmetrical spinnaker, survey/bottom paint 10/07. Autopilot, radar, Newport heater, new panel/wiring throughout. Electric windlass, sin inverter, charger, etc. Cruise ready, beautiful. Visit: <http://web.mac.com> \$41,000. (510) 798-3617.



**DOWNEAST 32 CUTTER, 1977** in fair condition. Needs bowsprit repair, paint, varnish. Good mechanical condition. Have Stalocs and wire for standing rigging. Mast is lowered on deck, ready to truck. Located in Santa Cruz, slip not included. \$18,000/offer. (510) 912-8946.

**WESTSAIL 32, 1976. \$35,000.** For sale in SE Asia. Hasse Port Townsend mains'l, stays'l, spinnaker. Perkins 4-108, 2,500 hours, runs great, new heat exchanger. Contact seller for complete inventory and more photos. Read about 4-year voyage: <www.micoverde.com> Email: mywestsail@gmail.com.

**1965 CHEOY LEE LION.** Fiberglass-hulled sloop/cutter. Roller furling, serviceable main, dodger and full covers. Propane stove and H2O heater. Yanmar diesel with 500 hours. Too much to list. \$35,000/obo. Call or email for more details. (707) 688-2314 or webmaster@deltamarina.com.

**CATALINA 320, 2006.** Almost new. 53 hours on Yanmar engine, ultra-leather interior, dodger, cockpit cushions/table. 8" LCD RAY C80 chartplotter, RAY 60 wind/knot/depth/repeater. 2-kw radar, ICOM VHF, autopilot ST4000. 6' fin keel, Martec prop, many extras. \$129,000. (408) 353-3393.



**HUNTER 340, 2001.** New chartplotter/radar/GPS. Optima batteries. New dodger. 20" flat TV/DVD. Autohelm, roller jib, full-batten main, lazyjack. 27-hp Yanmar, wind/speed/depth instruments, windlass. New bottom paint. \$82,000. Call (707) 647-2693 or jhsuds@juno.com.

## 36 TO 39 FEET

**CAL 39, 1979.** Excellent condition and loaded with new upgrades and extras, list available. Monitor windvane, dodger, bimini. Beautiful clean interior. Great engine and sails. Ready to cruise or sail the Bay. Sausalito slip possible. \$77,000. Call (415) 846-6919 or sailonbaby@gmail.com.

**ISLANDER 36, 1977.** Perkins 4-108, new rigging 2002, 2 self-tailing Harken 44s, 2 self-tailing Barlow 25s. Dodger, covers, holding tank, macerator, propane stove/oven, radar, chartplotter, VHF, bowroller, 2 anchors/chain and rode, carpets/curtains, Avon/ob. Alameda Marina #204. \$55,000/obo. Arnie (415) 999-6751 (cell) or (415) 383-9180 (hm) or email: arnoldgallegos@comcast.net.

**CLASSIC LAPWORTH DESIGN L-36.** 36-ft LOA, mahogany hull. In water and sailing, good sails, great-running Yanmar 3-cyl diesel. Needs paint, varnish, some woodwork projects. \$8,700/obo. (707) 964-0958.



**FAST PASSAGE 39.** Legendary cruising yacht. Two-time Hawaii, three-time Mexico vet. New engine, prop, dinghy, dodger, gennaker. Much much more. \$140,000. For details, email: DRJY2K@aol.com.

**ERICSON 39-B, 1976.** Excellent live-aboard and cruising boat. Just back from Mexico/Hawaii. This very well maintained and equipped boat has too many features to list here. Go to: <www.queserasailing.com/ericson39b.htm> for details and photos. \$65,000. Greg (415) 209-3461.



### Marine Architecture

John Seward  
105 Edison Ave.  
Corte Madera, CA 94925  
(415) 924-0429 • nims65@gmail.com

Brochure Available

### Marine Construction

Millerick Bros. Coast Marine  
PO Box 357, Cotati, CA 94931  
(707) 829-2507  
(707) 823-1954 (fax)

Yacht Repair  
Design / Consulting

Custom Interiors  
Exterior Joinery



### STEVE'S MARINE WOODWORK

60 C Libertyship Way, Sausalito  
jonessail@aol.com • (415) 332-2500

### CATALINA 32, 2004 • Purchased New Dec. 2005

Loaded • Like New • Only 16 Hours! • Sailing Instruments • Autopilot  
Raytheon E-80 GPS/radar • Tabernacle Mast • Windlass • Refrigeration  
\$119,000 • View Specs & Photos: <www.yachtworld.com/yachtsource>

Bob Sherman • YachtSource • (619) 847-1122

### PROFESSIONAL YACHT DELIVERIES

60 years of combined experience, 100,000 miles at sea. Rest assured that  
**Greg Snead (415) 846-6919 or Phil Howe (415) 290-1659**  
will get the job done in a safe, professional manner. Call for details.





**BRUNO'S  
Island**

30-50 ft.  
Slips Available

**(916) 777-6084**

**www.BrunosIsland.com**

On the scenic Delta Loop  
1200 W. Brannan Island Rd., Isleton, CA



**You don't want  
an ordinary  
desk job.**

Begin an  
extraordinary  
career in  
boatbuilding, yacht  
design, marine  
systems or  
composites.

**The Landing School**

**www.landingsschool.edu**

**MARINE  
ENGINE CO.**

PERKINS • YANMAR • ATOMIC 4 • VOLVO  
WESTERBEKE • UNIVERSAL • BETA MARINE



**CALL NOW FOR LOW ENGINE QUOTES**

- Engine Repowering and Rebuilding
- Engine Sales, Service and Parts
- Complete Marine Engine Service

**(415) 332-0455**

**Ryan's Marine**

*Specializing in Marine Electrical Services  
for Your Boat*

- Electrical system installations from inverters to electronics packages
- Troubleshooting of existing systems
- Dealer for the complete Balmar product line
- Head and holding tank installations

**(510) 385-3842**

Ryan Schofield  
Owner since 1997

email:  
rssailor@yahoo.com



**CATALINA 36, 1986.** Below-deck autopilot, radar, electric windlass with gypsy and capstan, 45-lb anchor with chain rode, refrigeration, propane oven/stove/BBQ, high-output alternator, two 8D and one Group 27 battery, inverter, dodger, bimini and more. \$55,000. (510) 219-9116.



**INGRID 38, 1983.** Strong, reliable, blue-water cruiser. An excellent example of William Atkins double-ended design. Cutter rigged, Monitor vane, Autohelm autopilots, Yanmar 3QM30, 130 gallons fuel, 200 gallons water, 12' Avon and 5-hp Merc, huge inventory of gear and spares. Stored on the hard, located in finest cruising grounds in the Med, Ionian Greece. Available late April 2008. \$89,500. Email: edpauhana@hotmail.com or (360) 582-1173.



**ADVANCED NOTICE THAT** the great Schumacher 39 *Recidivist* will be available for purchase after her return from Hawaii in 2008. After sailing my dream with a race to Cabo and 3 consecutive races to Hawaii, I plan to sell *Recidivist* to the next person wanting to live their dream. Cruising in Mexico is next on my list. Email: kolcott@sandis.net for more info.

**CORBIN 39 PILOTHOUSE, 1985** (nee 1979). Numero uno, top-rated blue-water cruiser. Sailed sparingly during last ten years by second owner. Berthed in Emeryville slip. See <http://myworld.ebay.com/ebaymotors/lesterhel/> Asking \$54,500.

**TAYANA 37, 1976.** Proven offshore passagemaker designed by Bob Perry. Beautiful interior, all new fittings below waterline. 1,000 hours on perfect running 4-108 plus another parts engine. Some sails still new in their bags. Needs mast and boom. See: <www.cranialmining.com/tayana> \$35,000. (510) 931-6489.



**DOWNEAST 38 CUTTER, 1978.** 38' length, 12' beam, Farymann V-twin diesel with 600 hours. Solid no-leak boat with 10 replacement stainless ports, Aries windvane, gel batteries, deck re-glassed on inside. Needs headliner, seat covers. \$39,500. Ken (707) 996-9054.



**CAPE DORY 36 CUTTER, 1984.** Exceptional example of Carl Alberg design. Many new and upgraded systems/parts. Full details on Cape Dory owner's website. Will send photos and equipment list. \$85,000. (530) 885-4460 (eves) or (530) 518-5971 (cell) or email: john.nebilak@aerojet.com.



**C&C 37, 1982. *Bad Puddy Cat.*** Proven race winner. Full set of UK tape-drive sails. Four spinnakers. Full set of Raymarine instruments. Garmin chartplotter GPS, Raymarine S1G autopilot, radar, folding prop. Much, much more \$64,900. Call Charlie (650) 851-4160 or cwatt@woodsidentg.com.

### 40 TO 50 FEET

**PETERSON 44 CENTER COCKPIT** cutter, 1977. Two staterooms, two heads. New Yanmar, LP, fuel tanks. Robertson autopilot, radar, dinghy, ob. \$119,000. San Carlos, Mexico. Call or email for complete list and photos. (520) 742-2727 or svubetcha@aol.com.



### SAILBOAT TRANSPORT

Long Haul • Anywhere between San Diego & Blaine  
24 to 35 feet • Up to 13,000 lbs. • Experienced • Can rig  
call\_norm@shaw.ca • (604) 897-1167

### WOODRUM MARINE

Specializing in custom interior  
cabinetry, tables, cabinets, countertops,  
cabinsoles. For power or sail.

**CARPENTRY**  
Mobile cabinet shop  
Contact Lon Woodrum at:  
**415-420-5970**  
www.woodrummarine.com



### NOR-CAL COMPASS ADJUSTING

Magneuto™ System Exclusively  
Boat Remains in Berth • Eliminates Deviation  
Authorized Compass Repair • All Major Brands  
Hal McCormack • Phone/Fax: (415) 892-7177



**HARDIN 40-FT SEA WOLF.** Best of Bill Garden's deepwater cruisers. *Sea Wolf* is in San Carlos, Mexico ready to cruise now. Clean, brite, fully operational with dinghy, outboard, davits. \$49,500. (707) 815-5111 or [jghague@yahoo.com](mailto:jghague@yahoo.com).



**BENETEAU 45f5, 1991.** Pristine. Never chartered. Elegance, power of Bruce Farr hull lines combined with design beauty of Pininfarina in legendary First Series. Racing around buoys or sailing across oceans, this is your boat. Three cabins, two heads, sloop tall rig, both Kevlar and Dacron sails, deep keel, B&G Network electronics, radar on stern tower, SSB, genset, watermaker, etc. Fully equipped to cruise or race. Located in Santa Barbara. Possible use of 50-ft slip. \$179,000. (805) 692-8856.



**LONE STAR, DOUG PETERSON'S** SORC Serendipity 43, 1980. Refit 1995-97, into an elegant, comfortable, high-performance cruiser. Daylight crossings between San Carlos and Punta Chivato will delight the skipper and crew. Touches of home include: parquet floors, entertainment center, custom galley, china closet, wine and goblet display, cedar-lined compartments for clothes and toiletries, linen locker, 2-person shower and large, comfortable berths. Lying in San Carlos, Mexico. \$89,950. For brochure and pictures, contact (925) 917-0913 or [svlonestar@yahoo.com](mailto:svlonestar@yahoo.com).

**LANCER 44 PILOTHOUSE** motorsailer, 1982. Capable, comfortable cruiser in outstanding condition. Twin Perkins 4-236 diesels. Extensively refit and equipped including new engines, rigging, plumbing, galley, interior, electronics and much more. Ready to go in Newport Beach. \$129,000. (949) 500-6567 or [anadebal@yahoo.com](mailto:anadebal@yahoo.com).



**MILLER 44.** Big, strong, fast performance cruiser. Center cockpit, cutter rigged. Fully equipped to cruise anywhere. Price \$129,000. For full specs and pictures, see website: [www.capricious-sailing.com](http://www.capricious-sailing.com) Any questions, email: [capricious1943@aol.com](mailto:capricious1943@aol.com).



**48-FT STEEL PILOTHOUSE, 1994.** Proven safe and comfortable circum-navigator built by Horizon Steel Yachts. Meticulously maintained, fully equipped, and ready to go around again. On the hard for the winter near Annapolis, MD. Visit [www.svgigolo.com](http://www.svgigolo.com) for full details. \$179,000.

**CAL 40, 1965.** Fiberglass sloop, #36, *Terral*. 30-hp diesel. Classic boat in average condition. Destroyer steering wheel, one mainsail, two jibs. No extras. Moored near Acapulco. Asking \$20,000. Email: [dougandmarion@hotmail.com](mailto:dougandmarion@hotmail.com).



**CATALINA 400, 2004.** Yanmar engine, 56 horse, 135 hours. Bowthruster, electric winch, windlass, all two-speed winches, two staterooms, two heads, flat screen TV, stereo. Immaculate, absolutely beautiful, everything like new. Located Richmond, CA. \$218,995. (916) 774-1474 or [rdsinor@yahoo.com](mailto:rdsinor@yahoo.com).

**1985 J/41 SAILBOAT.** This boat is a knockout and loves a breeze. She has been fully restored by a boatyard and needs nothing. Bottom is epoxy barrier coated. Sails are in new condition used for regattas only. Hull and deck have both been refinished. \$79,900. Located on Great Lakes. (716) 440-2096 or email: [markkirby@roadrunner.com](mailto:markkirby@roadrunner.com).



**47-FT CUSTOM-BUILT CUTTER, 2004.** Fiberglass, insulated, 85-hp Perkins diesel, generator, wheelhouse, full keel, new sails, roller furling, radar, autopilot, dual hydraulic steering. Liveaboard, shower, workshop, cruise ready. Well built, low maintenance. Owner's health forces sale. \$575,000. (541) 888-5688. See: [www.hyssop.com/boat/](http://www.hyssop.com/boat/)



**WAUQUIEZ CENTURION 45.** High quality, very safe performance cruising yacht by Wauquiez, designed by Dubois with stellar record for fast, comfortable offshore passages. Solid FRP hull, masthead sloop, removable cutter stay and stays'l, dyform rigging, owner's layout, fine European joinery. Icom SSB and VHF, Furuno radar, Garmin GPS, Raymarine ST 7000 autopilot, Harken furling, full-batten main, Windpilot servo-vane, swimstep transom, Lofrans electric windlass, dual refrigeration, new Balmar alternator/smart charger, 1000w inverter, AGM batteries 2006. Too much to list. Priced to move at \$185,000. 04/07 drydock survey available. Caribbean, South Pacific, Hawaii passages with up to 200 mpd made good. This boat can go anywhere you want. Photo catalog and inventory available. For more info contact: [tunes@hawaiiintel.net](mailto:tunes@hawaiiintel.net) or call (808) 826-6050.



**50-FT ALEUTIAN KETCH, 1977.** Dual cockpit model, large aft stat room with tub in head, large salon, two staterooms fwd, walk-in engine room. good condition throughout. \$120,000/or trade for 40+ ft. diesel powerboat. (562) 706-4334 or [sailfast6@verizon.net](mailto:sailfast6@verizon.net).

## 51 FEET & OVER



**HUNTER 54, 1983.** Cruise equipped, EPIRB, raft, dinghy with outboard, windlass, furling jib, watermaker, fridge/freezer, radar, VHF/RAM, SSB. 2006 survey. Much more. Located La Paz, BCS, Mexico. \$105,000. Ron Rowley (801) 870-7110 or fax (801) 924-3400 or email: [ronrowley@earthlink.net](mailto:ronrowley@earthlink.net).

**ROBERTS 53 STEEL KETCH, 1985.** \$180,000. Your dream boat already in SE Alaska. Motor/sail/liveaboard or charter (U.S. hull). Well maintained, passagemaker, new pilothouse in 2007. See photos, specs, surveys and equipment list at [www.robertsforsale.com](http://www.robertsforsale.com) or call (907) 463-5511.



**1928 NEW ZEALAND 78 SCHOONER.** 58'LOD, 16'6" beam. Big, strong, copper-riveted, triple-planked in Kauri. Detroit diesel, radar, AP, watermaker, genset, shower, 3 staterooms and much more. Bluewater world cruiser. \$125,000. (239) 352-2971.



Specialists in Marine SSB radio and HF E-Mail

ICOM Marine Radios, Furuno, SCS/Pactor, McMurdo EPIRBs



**HF RADIO ON BOARD**

Communication is our Business!

[www.hfradio.com](http://www.hfradio.com)  
(510) 814-8888

*SailMail!*

**'Lectronic Latitude for Puddle Jumpers**

When you're 2,000 miles from nowhere, you'll be glad to know you can still get the text of 'Lectronic Latitude via Sail Docs on SailMail. ~ ~ Send an email to [query@saildocs.com](mailto:query@saildocs.com) with 'lat 38' in subject line ~ ~

## BOAT • LETTERING

[alphaboatsue@aol.com](mailto:alphaboatsue@aol.com) • (510) 599-1197 • [www.alphaboatgraphics.com](http://www.alphaboatgraphics.com)

Creative and durable lettering and artwork for your boat

**HARDIN 44 KETCH • ESTATE SALE • MUST SELL**

1979 World Cruiser • Fiberglass hull • Wood masts • 5 sails  
Roller furling jib • Dinghy • 8-man liferaft • 3 Solar panels • Inverter  
Lying La Paz • Complete specs: [www.yachtsus.com](http://www.yachtsus.com) • **Make offer**

Carl (619) 370-8000 • [tracomm@tracomm.com](mailto:tracomm@tracomm.com)

## VOLVO PENTA

Specialist Dealer Since 1980

ESKELUND MARINE • (510) 523-7670

1913 Clement Ave • Alameda Marina • Bldg 13 at Pier 2

**SMALL AD, SMALL PRICES • RIGGING ONLY**

Standing and running rigging, life lines, furling gear, winches, line, windlasses, travelers, wire and terminals, blocks, vangs, etc. Problem solving is our specialty. We are a rigging shop specializing in discount mail order. Free catalog.

[www.riggingonly.com](http://www.riggingonly.com) • (508) 992-0434 • email: [sail@riggingonly.com](mailto:sail@riggingonly.com)



# CNI MARINE SERVICES

Electrical, Mechanical and Plumbing Repairs  
New Systems and Electronics Installations  
Deliveries and Charters  
Boating Instruction



**Capt. Steve Neil**  
25+ years marine experience  
100-Ton USCG Licensed Master  
Office 925-685-6634 • Cell 925-639-1713  
[www.cnimarine.com](http://www.cnimarine.com)  
[steve@cnimarine.com](mailto:steve@cnimarine.com)

# VOLVO PENTA

ENGINES • PARTS • SERVICE

We Ship Anywhere

## 1-800-326-5135

(415) 453-1001  
FAX: (415) 453-8460  
[www.helmutsmarine.com](http://www.helmutsmarine.com)  
619 Canal Street  
San Rafael, CA 94901

Call us for your nearest Volvo Penta dealer 1-800-326-5135



MARINE SERVICE INC  
AUTHORIZED POWER CENTER

## STAINLESS STEEL SCREWS, BOLTS, NUTS & MORE

[www.BOSUNSUPPLIES.com](http://www.BOSUNSUPPLIES.com)

See our complete catalog & order on the Web.

Stainless Steel Marine Hardware,  
Rigging & Fittings at Reasonable Prices.



Or call toll-free for catalog and to order

**(888) 433-3484**

## PRIME FABRICATION

Marine Hardware and Custom Metal Fabrication

- Stainless Anchors - Plow, Fluke, Claw & Ace
- Table Pedestals • Flopper Stoppers
- Helm Seats • Handrails

Ph 949.496.1348  
Fax 949.496.1341  
[www.primefabrication.com](http://www.primefabrication.com)  
33081 Calle Perfecto, Suite B  
San Juan Capistrano CA 92675



## CLASSICS



**SEA BREEZE 35 SLOOP, 1964.** All glass, teak trim, great condition, good liveaboard, cruiser or daysailer. New canvas, Yanmar, Harken furler, stainless radar arch, etc. Easy to singlehand. Located in Southern CA. Reduced \$28,000. (562) 706-4334 or [sailfast6@verizon.net](mailto:sailfast6@verizon.net).



**26-FT CATAMARAN, 2000.** 26' x 15'. Core cell construction, open solid bridgedeck, 9.9-hp 4-stroke electric start, sleeps 4, bimini with 3-sided enclosure. Located near Rio Vista, CA. Asking \$26,000. (916) 203-8517.

## POWER & HOUSEBOATS

**43.5-FT LaBelle TRAWLER.** Sausalito outstanding view berth. Volvo diesels, 500 hours, 7.5 Onan. Roomy glass-enclosed sundeck. Full canvas. Large custom galley. Master with walkaround queen, tub + comfortable guest stateroom with large bed, head. Excellent workmanship/condition. Asking \$159,000/obo. May finance or rent. (415) 331-5251.

## MULTIHULLS



**CORSAIR F-27, 1988.** New trailer and full cover. Two mains, two genoas, two spinnakers. VHF, Loran and handheld GPS. Dry-stored in Morro Bay. \$42,900. Call (805) 773-1110 or email: [davidprewett@aol.com](mailto:davidprewett@aol.com).



**65-FT WOOD CLASSIC, 1939.** Heavy built ex-trawler. GMC 12V-71, 21-kw generator. Full electronics. Lots of equipment. Ready to go. Would make great conversion. More pics/details: [ancona@mcn.org](mailto:ancona@mcn.org). Asking \$112,000 or any reasonable offer. Call (707) 964-5423.



**ATHENA 38, 1997.** Rio Dulce, Guatemala. *Blue Moon's* in good sailing shape but needing cosmetics. Details and photos aplenty for cash buyers. \$135,000 with tools, spares etc. and year-old hardbottom Caribe and 15-hp outboard. Email for specifics: [aweliversudden@yahoo.com](mailto:aweliversudden@yahoo.com).



**30-FT WILLARD VEGA SEARCHER.** Excellent little ship for 2, good for 4. Super condition in/out. All systems in excellent condition. Full electronics. All safety gear, full head, 100 gals fuel, 100 gals water. See to appreciate. \$46,000. Call (650) 207-6898 or (650) 851-3402.



## MARINE SURVEYS • Jan Van Sickle

Member: SAMS - AMS, ABYC & IAMI  
Ultrasound Thickness Testing of Steel & Aluminum  
[jtvs@post.harvard.edu](mailto:jtvs@post.harvard.edu) • [www.vintageyachts.org](http://www.vintageyachts.org)  
**(707) 939-9131** • No travel charge within Bay Area

## MARINE ENGINE CO.

Complete Engine Services • Gas & Diesel  
30 Years Experience • Reasonable Rates  
Tune-Ups • Oil Changes • Engine Rebuilding, etc.  
**(415) 332-0455**



**WINCHMATE**  
SELF TAILING CONVERSION

[www.winchmate.com](http://www.winchmate.com)

For Barient & Barlow #27 - #32

**(415) 460-5151**

**1943 STEPHENS BROS. WOODEN** tugboat. 73 feet, 18.5-ft beam, 60 ton. Extraordinarily unique. Within the fantastic fit and finish of a bright, exotic wood and stone interior lies an overbuilt WWII tug's charismatic conversion to a luxury (fully floating home equipped) residence. 1,200 sq. ft. of efficient liveable space, fully equipped updated residential kitchen, 2 fireplaces, Jacuzzi, washer/dryer, wet bar, functional office, significant storage options, skillfully engineered systems. Detroit 6-71, Kubota 8 kw (both call for servicing). Surveyor's comment: "This home afloat should be regarded as having one of the nicest-looking interiors on the Sausalito waterfront, vessel's interior is furnished to the highest standards and is impressive for its spaciousness and quality décor." \$450,000. Email: gvtomas@earthlink.net.



**CHRIS CRAFT 28 CATALINA EXPRESS** cruiser, 1977. Great family boat. Sleeps 6, VHF, depth, windlass, 6'5" headroom, repowered with 80+ hours. Berthed at Vallejo Marina. Must sell. \$10,000 \$8,000/obo. (707) 486-9647.



**32-FT CLASSIC MONTEREY.** Totally restored Monterey fishing boat, converted to day boat, sportfisher or Bay cruiser. All woodwork has been done. New fuel tanks, hydraulic steering, tinted glass, etc. GMC 2-71 diesel engine. Needs to be finished, such as controls, wiring, exhaust and finishing touches. Must be seen to be appreciated. \$45,000, will consider any reasonable offer. Pics/details: (707) 964-5423 or ancona@mcn.org.

**TRADE OR SALE OR DONATE:** 1974 68-ft x 20-ft working steel trawler/office/home. 1,200 sq. ft. of space. Legal live-aboard. Trade value: 45 to 70-ft sailboat or cash or terms. Be creative. Berkeley slip. See: <www.myclassicboats.com> Email: GaryKJennings@msn.com or call (510) 665-7716.

## PARTNERSHIPS

**CABO RICO 34, 1995.** Crealock-designed cutter, easy to sail. Safe, comfortable passagemaker. Beautiful boat equipped for Mexico and beyond. We're back, now your turn. Long-term lease/equity share. (707) 477-6980 or jack@hewatt.net.



**DOWNEASTER-STYLE BASS BOAT.** Fortier 26, 2004. Classiest fishing/picnic boat in Santa Cruz Harbor and Monterey Bay. Semi-displacement, powered by Yanmar 260, radar, fishfinder, GPS, etc. Cared for as part of our proud family and want to keep her that way. 10-ft beam provides very stable fishing platform and plenty of room for recreational cruising. Seeking a partner, please. Call (650) 926-9797 or (650) 400-1041.

**GREAT OPPORTUNITY FOR A** prudent sailor. I'm moving to SoCAL for 2 years and can not bring my boat with me. I'm looking for an ASA or US Sail-trained, responsible sailor to pay slip fees (Berkeley Marina) and maintain my Newport 28 sailboat in exchange for use. I will need to use the boat a maximum of 1-4 days per month, otherwise she is all yours. No liveaboards. \$290/month. Email for details: atwoodhome@comcast.net.



## SOUTH OF THE BORDER

**SWALLOWING THE ANCHOR?** Lots of recent sales in San Carlos mean we're looking to add to our roster of well-equipped cruising sail and power boats. Find out why San Carlos Yachts is "a different kind of brokerage, in a different kind of paradise." Call toll-free from the U.S. or Canada (877) 694-4568, in Mexico 01 (622) 226-0044. Email: info@sancarlosyachts.com. Website: <www.sancarlosyachts.com>

**LEARN TO SAIL** in the Sea of Cortez. San Carlos Sailing School, an ASA school based in San Carlos, Sonora. Specializing in learn-to-sail cruises, vacations. Also offer boat rentals, day trips. See: <http://mexicosailing.com> or please call (800) 874-4830.

**CONDO RENTALS NEAR VALLARTA** yacht club. Two adjacent condos overlooking Paradise Village Marina. Each 2 br, 2 bath with Jacuzzi, pool and amenities. Access to Sports & Beach Club. Rent one or both. Call (925) 208-1601 or 011-52 (322) 297-7559 or nancywmoore1@aol.com.

**MEXICOLDER.** Your answer to frosty drinks in Mazatlan and tropical hideaways. Super efficient fridge freezers, lower than U.S. prices. 100% cruiser satisfaction. Visit <www.mexicolder.com> for helpful advice. Celebrating 30 years of those wonderful tinkling ice cubes. Email: sales@mexicolder.com.

**MARINA RESIDENCE:** Condo for rent overlooking Paradise Village Marina located on Banderas Bay near Puerto Vallarta. 1 bedroom, 1 bath. Marina view, watch the boats from your patio. Many amenities. For resort information and location call (916) 367-6292 or email: HNDJohn@starstream.net.

**BRISTOL 35, 1970.** Offshore equipped. 4-person liferaft 2005, EPIRB 2005, newer Yanmar 27 hp, sea anchor, Fleming windvane. 2005 Hasse trysail, storm jib. 2005 upgraded electrical, rigging, storm windows. Clean, comfortable cruiser. \$35,000. La Paz. (360) 774-0918.

**PLAN YOUR MEXICAN GETAWAY NOW** at the brand-new, gorgeous Cielo Y Mar condos. Located in Punta Mita, 35 minutes from Puerto Vallarta, available to rent from private owner. Right on the beach, 10 feet from the water, they offer spectacular views of ocean and mountains, the biggest infinity pool in the area, an endless beach, great advanced and beginning surf breaks, great fishing, tremendous views of whales, bird life and the islands. While uncrowded and tranquil, it's just a five-minute walk to several waterfront restaurants. Choose from a spacious and beautifully furnished one or three-bedroom unit, or an amazing two-story penthouse with lovely shade trellis on the top floor. See details: <www.puntamitabeachfrontcondos.com> To reserve, call (415) 599-5012.



## TRADE

**TRADE OR SALE OR DONATE:** 1974 68-ft x 20-ft working steel trawler/office/home. 1,200 sq. ft. of space. Legal live-aboard. Trade value: 45 to 70-ft sailboat or cash or terms. Be creative. Berkeley slip. See: <www.myclassicboats.com> Email: GaryKJennings@msn.com or call (510) 665-7716.

## WANTED

**SELLING OUR HOUSE.** Looking for a bluewater cruiser. 38 ft or more, for a couple. Prefer center cockpit cutter or ketch. In Mexico. Write: PO Box 1685, Lake Isabella, CA 93240 or call (760) 379-6369.

**42 TO 52-FOOT SAILBOAT** to purchase and convert to USCG-inspected charter sailing vessel in SF Bay. Must be US built and in good condition. Good sailing performance is a plus. Cash sale possible. Call Kirk (650) 492-0681 or captkirk@sfbaysail.com.

## GEAR



**63-FT ALUMINUM MAST, BOOM,** sails, winches, package sale: \$16,995. Was bought new and has been stored inside since. Bought for a 53-ft Roberts cutter. 21-ft boom, spreaders, sails in crates, never opened. One stainless steel prop shaft, 1-3/8" with tube, stuffing box, packing, bearing. Two Enkes AR36ASC winches. Two 60# plow anchors. 36-ft 1-1/4" stainless steel track. Two Aqua Signal mast lights. 35 Schaefer blocks, cleats, hardware. Call (707) 964-6712 or (707) 272-4811.

**1999 YANMAR 30-HP DIESEL** freshwater-cooled with 100-amp Balmar and 3-stage charger, \$4,500/obo. Engine installed in Olson 40 in 2000 and removed in 2007, excellent condition. See video on youtube, search 'olson 40 gear'. (650) 966-8767.

## All-MARINE Electronics & Electrical

- ◆ System Design ◆ Troubleshooting / Repair ◆ AC & DC ◆ Quality Installation ◆ Licensed & Insured ◆
- ◆ Radio & RADAR ◆ Antennas & Mastwork ◆ Integrated Navigation Systems ◆ Auto Pilots ◆
- ◆ Battery Monitoring Systems ◆ Alternators, Regulators ◆ Solar ◆

Alameda, CA -- (510) 523-6011

Charts, Cruising Guides, Software, Nav Tools, Flags, and More!

Electronic Navigation Specialists  
OceanGrafix Charts-on-Demand



**WAYPOINT**  
LAT: 37° 46.61' N LONG: 122° 15.01' W  
**www.waypoints.com**  
(510) 769-1547

Learning to sail has never been easier ...

SailingWindWheel.com



Classy Idea!

www.latitude38.com

Place your Classified Ad on our Website with your credit card. Fast, easy, convenient and secure. Deadline is always the 18th at 5pm. Your ad will run in the magazine, then be posted on the Website. Try It!

## DELIVERIES & PRIVATE SAILING INSTRUCTION

Learn to handle your boat in a safe and confident manner. 25 years and over 30,000 miles of cruising experience. 50-ton license • Sail and tow endorsements • Caribbean and West Coast deliveries  
(805) 540-4667 • markocina@hotmail.com

## COMPLETE MARINE WOODWORK

Design / Restoration • Expert European Craftsmanship • Interior / Exterior Repairs / Maintenance • Marine Windows & Frame Replacement  
Wood & Dry Rot Repairs • Varnish Work • Marine Painting  
References Available • Reasonable Rates • Call (415) 331-6718



## QUALITY SAILS FOR LESS!



**MAINSAILS  
MIZZENS  
STAYSAILS  
HEADSAILS  
CRUISING SPINNAKERS  
MAINSAIL COVERS  
ALL CUSTOM FIT**

(510) 769-4858 • leesailsnc@yahoo.com

2021 Alaska Packer Pl. • Grand Marina • Alameda, CA 94501

**SAILMAKERS TO THE WORLD!**

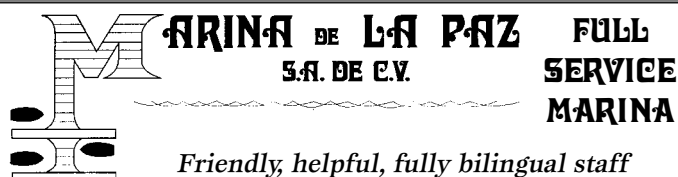

*Friendly, helpful, fully bilingual staff*

All new hardwood docks • Wireless Internet  
Dinghy landing with potable water  
New protective piling & sheetpile breakwaters • And more!

TEL: 01152 612 122 1646  
email: marinalapaz@prodigy.net.mx

**www.marinelapaz.com**

Apdo. Postal 290, La Paz, 23000, Baja California Sur, Mexico

## WIRELESS E-MAIL



**SEATECH SYSTEMS™**  
Computerized Navigation & Communication  
800.444.2581 • 281.334.1174  
info@sea-tech.com www.sea-tech.com

Call for Info on SeaTech Packages & CAPN Demo Disk

## Bilge Steam Cleaning Oil Changes

From our boat to yours, we bring the SERVICE to YOU



## GEAR, CONT.

**SEASIDE MARINE MEDICAL KIT.** Ideal offshore cruising kit in heavy-duty bag with shoulder and hand straps. Includes wide range of medical supplies: Suture, EENT, and GI kits, skin and burn preparations, equipment, antibiotics, medications, etc. Instructions included. Excellent condition. \$400. (808) 721-4666 or caw.caw1@yahoo.com.

**BRONZE GOOSENECK FOR boomgal-lows,** \$250. 80-lb fisherman's anchor, \$150. 1996 12-ft Porta-Bote, used four times, \$800. 2007 5-hp Nissan short shaft, still needs break-in, \$1,000. Engel fridge/freezer, \$350. Kenmore icemaker, home/light industrial, \$150. Mast, solid Sitka, 31' x 5-3/4" x 4", \$350. (415) 461-9425.

**HONDA 8-HP 4 STROKE MOTOR.** Just serviced. Possibly needs water pump. Includes fuel tank and hose. No longer needed. \$850/obo. (831) 247-7939 or hawknest1@prodigy.net.

**VOLVO MD3B 36-HP, 3-CYLINDER** diesel, very reliable. In boat. 1/2 gal per hour. Rebuilt 2003. Upgrading hp for cruising. \$2,000. (707) 561-7160 or rbrandes@magnoliagh.com.

**58-FT FURLING MAST.** Swept double spreaders and boom. Anodized, 2 years old, all in excellent condition, including mainsail, solid vang, and step. Currently on 49-ft sloop, will be available in January. Make any reasonable offer. Call (707) 290-4010.

**MY COCKROACHES ARE STARVING** so must sell my engines for low \$\$\$  
Westerbeke W18 18 hp, \$2,000. BMW 30 hp, \$2,400. Both excellent condition and complete. Two Universal 5411s. A-4 replacements, cheap. (415) 272-5776 or TheCockRoachKing@gmail.com.

**74-FT MAST DESIGNED** for catamaran. Best offer. (415) 269-5165.

## MISCELLANEOUS

**CAPTAIN'S LICENSE CLASSES.** OUPV (6-pack)/100-ton Masters, plus towing and sailing endorsements. USCG-approved courses. Successful completion satisfies USCG exam requirements. Offered by US Maritime Academy of California. Weeknight classes in San Mateo. Call Mike (650) 298-9489.

## CLUBS & MEMBERSHIPS

**SINGLE SKIPPERS AND CREW** of all abilities are invited to attend Single Sailors Association's <http://www.singlesailors.org/> meeting held 2nd Thursday, Oakland Yacht Club, 1101 Pacific Marina, Alameda, 94501. Social 6:30 pm. Meeting 7:30 pm. Members enjoy daysailing, raftups and social events. Guests welcome. (510) 233-1064.

**CLUB NAUTIQUE PASSAGE MAKER** Couples Membership. Includes all U.S. sailing courses, Basic Keelboat through Offshore Passagemaking, and charter discounts. Asking \$4,000. This is the best and safest way to learn sailing, from the best school. Phillip (925) 820-5836.

## NON-PROFIT

**BOATING SKILLS AND SEAMANSHIP** Course, U.S. Coast Guard Auxiliary Flotilla 12. Covers basics of boating. Meets Tuesdays 7:30-9:30 pm for thirteen weeks beginning February 5, 2008, at Sausalito Cruising Club. Enrollment limited. Course fee \$75, includes textbook. Call Margrit Keyes (415) 924-3739 or margritkeyes@sbcglobal.net.

**FREE BOATING CLASS: Boating Safety,** 4 Lesson, begins Jan. 22, 2008, offered by Santa Clara Power Squadron, Sail and Power Boating. Cost for materials only. Call DeWayn (408) 225-6097. For map or to register online go to <http://www.usps.org/localusps/santaclara/PE.htm>.

**MARIN POWER & SAIL SQUADRON** offers members free classes ranging from Seamanship to Celestial Navigation plus cruises and social events. Next Squadron Boating Course in Novato January 8, 10, 17, 19, 22, 24, 2008, all from 7 to 9 pm. Textbook \$50. For details and registration call (415) 924-2712.

## PROPERTY SALE/RENT

**CHARMING NEW 1400-SQ.FT.** cottages in Friday Harbor, on San Juan Island for sale by owner. Only two left out of four units. Beautifully done, quality throughout, easy walking distance to town. See at: <www.carlicottages.com> Asking \$435,000. (360) 378-0302.



## LEARN OFFSHORE NAVIGATION

From Celestial to GPS and Electronic Charts  
Course on CD • Instructors via Email  
**www.amwnavigator.com**

## WISE MARINE SERVICES

Refrigeration • Air Conditioning • Electrical • Engine Services  
Experienced in both Power and Sail systems  
**Roger Wise • (510) 418-7550 • rdwisesr@gmail.com**

## BLUE PELICAN MARINE

A sailor's consignment store now open at Grand Marina, Alameda  
Sails • Winches • Instruments • Brass • Collectibles • Sailing Books  
Charts • Small Outboards • Hardware • No large items • No junk  
**(510) 769-4858 • bluepelicanmarine@sbcglobal.net**

**ATTENTION SAILORS:** I have a house and large boat dock at Point Richmond for rent. Exclusive, large 5 br, 3 ba, fireplace, near Richmond Yacht Club. Must see. \$3,500/month or possibly for sale. Call (510) 222-2312.



**CATALINA ISLAND, HAMILTON** Cove condo. Relax and enjoy the quiet off season. Sleeps 6, 2 bedrooms, 2 baths. Overlooking the ocean and pool. 3 nights \$400, 7 nights \$800. For photos and more information, email: CatalinaCondoCPYC@hotmail.com or call (650) 697-5854.

## BERTHS & SLIPS

**BERTH AVAILABLE.** 36-ft berth at Pier 39, San Francisco. Very close in. Rental by month or annually. (415) 474-2474.

**40-FOOT SLIP FOR SALE AT PIER 39.** \$15,000/obo. No liveboards. D Dock, Slip 17. Marina facilities include washer/dryer, toilet, shower, Internet, garbage removal. HOA \$200/mo. Excludes elect/phone. Parking \$3 per 12 hours, Pier 39 Garage. Email: stephaniekrames@aol.com.

## CREW

**EXPERIENCED CIRCUMNAVIGATOR.** Schooner returning from high Arctic seeks select crew members on legs: 1) Northern Norway-Scotland-Ireland; 2) Ireland-Spain-Portugal-Gibraltar; 3) Gibraltar-Sardinia-Tunis-Sicily; 4) Sicily-Crete-North Africa-Israel; 5) Israel-Greece-Italy-Croatia. Each leg approximately 4 weeks, June - October. Must participate fully and share expenses. Call Mike (505) 466-6326 or clairehorn@comcast.net.

**REMEMBER LN ADS?** Experienced female cruiser SO for "as long as it's fun". I'm a funny "one off" sailor with a great boat, life, kid (grown), pets. Established SoCal 50ish beach kid with an intense passion for life. sailor4life120@yahoo.com.



## SEGWAY OF OAKLAND

212 International Blvd., Oakland • Rent, buy, or lease  
All models in stock • New & Used • Only \$35 for a lesson  
(510) 832-2429

## OFFSHORE PASSAGEMAKING INSTRUCTION IN THE ATLANTIC

John & Amanda Neal are dedicated to providing hands-on, documented instruction aboard their Hallberg-Rassy 46 *Mahina Tiare III*, drawing on their combined 472,000 miles and 63 years of experience.

[www.mahina.com](http://www.mahina.com) • (360) 378-6131

## N.E. MARINE TITLE

Coast Guard documentation • Title/lien searches • Transfers • Mortgage filing • Escrow services

Local closing facility for brokers or private transactions

30 years experience of doing it right the first time

1150 Ballena Blvd, Alameda, CA • (510) 521-4925

## JOB OPPORTUNITIES

**WEST MARINE, THE NATION'S** largest retailer of boating supplies and apparel, has an immediate employment opportunity for a Cashier and Sales Associate. FT/PT available in our Richmond store. Boating and retail experience is a plus. We offer a competitive compensation package and generous product discount. Apply online at: <[www.westmarine.com](http://www.westmarine.com)> Store Located at 501 Canal Blvd. #D, Richmond, CA. 94804. EOE.

**CHARTER COMPANY LOOKING** for couple to run satellite base in beautiful San Juan Islands during 2008 charter season. Boat handling, basic maintenance and navigation necessary. Send resumes to ABC Yacht Charters, PO Box 129, Anacortes, WA 98221, or email: herve@abcyachtcharters.com.

**YACHT SALESMAN WANTED** for growing four-office brokerage. Openings in the Alameda and San Diego offices. Must have track record for listing and selling brokerage boats. Email: randall@rbyachts.com or call Ann (510) 292-8567 or Jack (619) 222-1907.

**MARINA ASSISTANT MANAGERS.** SF Marina anticipates recruiting for experienced marina assistant managers. Duties may include light marina maintenance, patrolling/providing security for marina-owned facilities and equipment and providing assistance in Harbor Office setting. For information, please email: lisa.nakamura@sfgov.org.

**PART-TIME CREW, 1 DAY PER WEEK** for beautiful 46-ft cruising sailboat in Sausalito. Local cruising 2008-2009, possibility of San Juans or Channel Islands in summer. Good mechanical and sailing skills, reliability, and references crucial. (415) 627-8304.

**SAUSALITO PERSONAL ASSISTANT** and/or boatworker. One or two people, start pt, can become ft career position. Help with business, organization, upgrading boats. Interests in mortgage and real estate brokerage, south of the border real estate, boat remodeling, sales. Lodging possibly included. (415) 331-5251.

**ULLMAN SAILS, NEWPORT BEACH** is growing and we are looking for an experienced Handworker. Bring your enthusiasm, commitment and appreciation of teamwork. Salary is commensurate with experience. Contact Erik Shampain at: eshampain@ullmansails.com or (714) 432-1860.



**LICENSED 6-PAK CAPTAINS.** Captain Kirk's Sailing is looking for excellent captains for the 2008 season. Part-time and weekend sailing on Sovereil 36 from Sausalito for 3 to 4-hour trips. *Flying Tiger* is a fun, fast boat to sail. Must have excellent sailing skills, good people skills and references. Steady work, good pay, flexible schedules and bonuses for the right captain. Call Kirk (650) 492-0681 or email resumé to [captkirk@sfbaysail.com](mailto:captkirk@sfbaysail.com). See <[www.sfbaysail.com](http://www.sfbaysail.com)> for info on business.

## BUSINESS OPPORTUNITIES

**WYLLIECAT IS LOOKING FOR** a partner with strengths that complement our design and construction skills. Finance - Marketing - Sales. Please visit three websites: <[www.wylliecat.com](http://www.wylliecat.com)> and <[www.sealifeconservation.org](http://www.sealifeconservation.org)> and <[www.hybridfishingboat.org](http://www.hybridfishingboat.org)> then call Tom Wylie (925) 376-7338.

**ESTABLISHED, PROFITABLE** skippered sailing charter company in SE Alaska for sale. Turnkey operation includes boat, permits, and training. Incredible scenery, wildlife, fishing. It's a tough job, but somebody's got to do it. See: <[www.soundsailing.com](http://www.soundsailing.com)> Email: svbob@soundsailing.com.

**1958 JEFFRIES, RESTORED.** Current USCG cert. for 49 pass. 45' L, 15' W. Major refit April 2007. GM 6-cyl engine, 509 trans, new wood. Glass over wood. Very unique vessel, includes Furuno radar, 2 VHFS, bow thruster, new 2006. All work done at KKM. Very well maintained. This is a great Bay boat, turnkey with websites. CA. liq. lic. \$240,000. Must see to appreciate it. (415) 859-7050.

**ASA SAILING SCHOOL, SAILING Club,** Charters and Catalina Yachts dealership offered. Fully established with great growth potential. Located in premium resort area of northern California/Nevada area. For details call (877) 542-1691 or [captaindeeper@yahoo.com](mailto:captaindeeper@yahoo.com).

**GREAT OPPORTUNITY TO TAKE OVER** and run a growing sailing charter business in Bay Area. Very affordable. The only requirements are knowledge of sailing and some business principles. Existing owner will train. Call (510) 499-9463 for details.

## TOO LATE TO CLASSIFY

**CATALINA 380, 2001 PARTNERSHIP.** Berthed at Sausalito Yacht Harbor. Full electronics, chartplotter, autopilot, and radar. Furling main and jib, cruising chute, Yanmar 40 with low hours, new dodger, electric windlass. Equipped for sailing and cruising: 2 cabins, centerline berths, innerspring mattresses, refrigerator, microwave, flat screen HDTV/DVD, electric head, and separate shower. Includes dinghy and outboard. Beautifully finished interior in ultraleather and Corian. Equity or non-equity shares available, as low as \$300/month, depending on usage. Call (707) 421-0366 or [csmsam@aol.com](mailto:csmsam@aol.com).



**MARINER 40 KETCH, 1970.** Bulletproof fiberglass hull, beautiful teak interior and outside trim. Safe, sturdy full-keel cruiser or comfortable liveaboard. 85-hp Perkins, new aluminum fuel tank and system, hot water, roomy head with shower, LectraSan, new windlass motor, all-chain rode, built-in DC fridge and new AC fridge, dodger, loads of storage, large tanks, good sails. Sausalito berth. \$39,000. Call (707) 454-6247.

**ERICSON 27.** Queen of the fleet. Baby forces sale. Marina Village. As is. First \$3,500 in the New Year takes her. James (415) 710-5741.

**WANTED: PORTHOLES,** Opening ss or bronze 5x12 hull opening. Angled spigot preferred. Givens, Elliot, or Winslow 4/6 man offshore pack, canister preferred. Call John <808> 291-3233 or [aeolus\\_99@yahoo.com](mailto:aeolus_99@yahoo.com).

**SAILS:** Spinny's: 1.5-oz white, SL 33.11, SMG 17.10, old but good, with turtle, \$100. 1-oz Hood, multicolor, SL 32, SMG 15, good shape, no turtle, \$250. .5 poly Haarstick, multicolor, SL 32, SMG 14, with repairs, with turtle, \$100. Jib: North Pentex #1, I=31, J=12, with sausage, from Laser 28, old, free with chute. Located SF. (415) 994-3500 or [jsgutoff@hotmail.com](mailto:jsgutoff@hotmail.com).



## VOLPAR, Inc.

(408) 986-0848 • (800) 258-4545  
Parts / Service • Penta Only  
10am-7pm PST every day including Sat-Sun  
email: [Volpar@Volpar.com](mailto:Volpar@Volpar.com)

# VOLVO PENTA

Visit our Website

[www.latitude38.com](http://www.latitude38.com)

*Electronic Latitude*, updated daily, in glorious color! Place a Classified Ad with your credit card on our secure server. Buy a LogoWear hat or t-shirt. Subscribe! Peruse some of our Archives as well as dozens of interesting links. **Try it, you'll Love it!!**



## Let Your Boat Make Money • Charter It

NEW and HUGE TAX BENEFITS

[www.spinnaker-sailing.com](http://www.spinnaker-sailing.com)

Spinnaker Sailing • South Beach Harbor, SF • (415) 543-7333





We care about sail care!



**San Francisco Service**

773 Andersen Drive, San Rafael, CA 94901

T: 415-453-2142 M: 510-333-4644

Hours: 8-5 M-F, Sat. by appointment

SAIL CARE ■ SAIL COVERS ■ YACHT COVERS ■ FLAGS ■ CRUISING PRODUCTS



Faster by Design  
www.northsails.com

**GEAR UP TO WIN!**

**CUSTOM EMBROIDERED SAILING GEAR**



JACKETS • SHIRTS • CAPS



**EMBROIDERY FACTORY**  
Benicia, California • 707.746.7625  
www.embroideryfactory.com

**HAWAII**

**LONG TERM DRY STORAGE**

*Clear Customs at our dock*

**GENTRY'S  
KONA MARINA**

HONOKOHAU HARBOR 156°1'30" W  
19°40'20" N

**888-458-7896**  
TOLL FREE

The friendliest boatyard in Hawaii

**Save Your Aft!**



Using one of our 1400+ patterns or your own pattern, let our craftsmen create a comfortable, durable, and stylish set of all-weather cushions for your cockpit. Find your custom, closed cell foam cushions at [www.bottomsiders.com](http://www.bottomsiders.com)!

**BottomSiders**

**BottomSiders**  
2305 Bay Avenue  
Hoquiam, WA 98550

Call Toll Free: (800) 438-0633  
Email: [cushions@bottomsiders.com](mailto:cushions@bottomsiders.com)  
Fax: 360-533-4474

**WEDLOCK, RAMSAY & WHITING**  
Marine Surveyors



Pre-purchase, insurance: vessel, engine, rig surveys

*Serving the Bay Area since 1980*

[www.wedlockandstone.com](http://www.wedlockandstone.com)  
**(415) 505-3494**

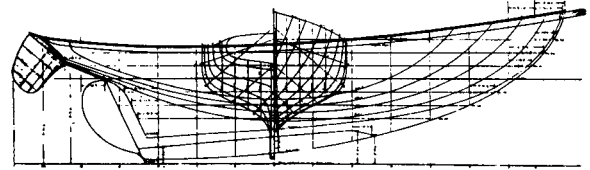

**MAKELA BOATWORKS**

*Family owned since 1948*

**Wooden Boat Building • Repair and Restoration**

19280 South Harbor Drive • Fort Bragg, CA 95437

**(707) 964-3963**

email: [howard@makelaboatworks.com](mailto:howard@makelaboatworks.com) • [www.Makelaboatworks.com](http://www.Makelaboatworks.com)

**Mobile Welding & Metal Fabrication**

Aluminum • Stainless • Cast Iron • Steel

*We Can Fix It or Make It New!*



Bonded • Licensed • Insured

[www.mrrpmwelding.net](http://www.mrrpmwelding.net)

email: [mrrpmwelding@yahoo.com](mailto:mrrpmwelding@yahoo.com)

**(650) 455-5229**

24-hour emergency

CA Lic. # 876283

**PRODUCT DESIGN**  
FOR THE MARINE AND  
WATER SPORTS INDUSTRIES  
**MECHANICAL & ELECTRICAL  
ENGINEERING**



**DESIGNS**

**E-M DESIGNS**  
171 Ocean Blvd.  
Box 97  
Half Moon Bay  
CA 94019-0097  
650-728-3406  
[www.emdesigns.com](http://www.emdesigns.com)

# STANDING RIGGING REPLACEMENT

Cruise or Race  
One Design Fleet Specials

## BUTLER RIGGING

(510) 672-2639

butlerrigging@sbcglobal.net



**Dare to be Different!**

**SOVEREIGN**  
BBQ & GRILLS  
AUSTRALIA

**Quality Features Include:**

- Seamless 316 marine grade stainless steel, beautifully finished
- Flame failure safety device, baffled air intake, easy clean drip tray
- Flat plate or grill/flat plate combination
- Two sizes available, suitable for boats from 20 feet onwards
- Standard mounting options to suit powerboats and sailboats
- Great for transom rails on sports cruisers
- Accessories include beach stands, covers and trays

Call for your local dealer, or for a free color brochure. **714-843-6964**  
email: sales@quickline.us www.quickline.us

**e<sup>1</sup>** Enviro Lua  
Environmentally friendly products

**Nature's Head Composting Toilet**

- No harsh chemicals
- Organic composting
- Only \$850 – includes hoses, brackets, fan
- No thru-hulls needed

(530) 383-4217  
www.envirolua.com

**BARNETT YACHT INSURANCE**

**Barnett Yacht Insurance, Inc.**  
PMB 389 • 2726 Shelter Island Dr.  
San Diego, CA 92106

**Our Insurance Programs Cover**  
Crew of Two  
Caribbean • Mexico • South Pacific • Worldwide

Call Toll Free: **866-463-0176**  
Fax: 619-226-8513 • email: sales@barnettyachtinsurance.com

For quotes, visit our website:  
**www.barnettyachtinsurance.com**

**Sailing Supply**  
Sailboat Hardware since 1972

Full-Service Rigging Shop:  
- Standing, Running rigging  
- Lifelines

Riggers to Olympic campaigns  
Friendly, knowledgeable staff  
**www.sailingsupply.com**

Authorized Distributor/Dealers for:

Alexander-Roberts	Lewmar
Camet	Ronstan
Forespar	Samson
Gill	Schaefer
Harken	Tylaska
Hayn	and many others
Kaenon	

**Sailing Supply**  
2822 Canon Street  
San Diego, CA 92106  
(800) 532-3831  
sailing\_supply@msn.com

**Hays Marine Transport**  
Specializing in oversized boat transport

Serviceing 48 States & Mexico  
**(813) 979-2900**

**jim@haysmt.net** **www.haysmarinetransport.net**

## ADVERTISERS' INDEX

AB Marine .....92	Aquatic Protection Agency ..220	Beta Marine Engines .....29	BVI Yacht Charters .....182	CYOA Yacht Charters.....183
ABC Yacht Charters.....185	Bair Island Marina .....88	Blue Sky Energy .....132	Cabrillo Yacht Sales .....224	Desolation Sound Charters.185
ABC Yachts .....226	Baja Naval .....204	Blue Water Marine Paints/ National Paint Industries....93	Chula Vista Marina .....204	DeWitt Studio .....159
ABI/Precision Lighting .....60	Baja Tourism Board .....53	Blue Water Yacht Ins. ....133	City Yachts .....17	Diesel Fuel Filtering .....147
Agape Villages.....26	Bailena Bay Yacht Brokers....30	Bluewater Network.....219	CNI Marine Services .....210	Discount Marine Hardware ..97
Alameda Marina/Pac.Shops.67	Barillas Marina .....143	Bo'sun Supplies.....210	Coast Marine .....24	Dockwise Yacht Transport....89
Alameda Prop & Machine....29	Barnett Yacht Insurance.....215	Boat Electric .....27	Conch Charters.....183	Dolphin Insurance Services Inc.....103
Albatross Yacht Charters ....185	Bay Island Yachts .....7	Bottom Siders .....214	Corinthian Yacht Club.....175	Downwind Marine .....54
Almar Marinas .....87	Bay Marine Boatworks.....57	Boy Scouts San Francisco...224	Cover Craft .....99	Doyle Sails .....65
Alpha Marine Systems .....101	Bay Marine Diesel.....218	Brisbane Marina .....63	Coyote Point Marina .....71	Easom Rigging .....175
Anacortes Yacht Charters...185	Bay Risk Insurance .....32	British Marine .....24	Cruising Cats USA .....95	Elliott Bay Yacht Sales.....219
Anderson's Boat Yard .....55	Beneteau.....59	Brunos Island Resort .....208	Cruising Direct Sails .....152	Elliott/Pattison Sailmakers ....98
Annapolis Performance Sailing .....175	Berkeley Marina .....205	Butler Rigging .....215	Cruising World Pacific.....220	EM Design .....214
	Berkeley Marine Center .....35		Cruising Yachts .....34	



**Delivered Worldwide\* just \$18!**

**Subscribe to  
Latitude 38  
eBooks**



Are you in Papeete, St. Martin, South Africa, Topeka, Amsterdam – or any of a billion other places where *Latitude 38* isn't distributed? The entire monthly issue is available online, now in easy to use PDF format.

To subscribe, go to [www.latitude38.com](http://www.latitude38.com), click on the eBooks link, and follow the easy instructions. We think you're going to love it!

*\*That is, anywhere in the world with Internet access.*

[www.latitude38.com](http://www.latitude38.com)

## Wm. E. Vaughan

Maritime Attorney, Arbitrator & Mediator

17 Embarcadero Cove, Oakland, CA 94606  
Mail: PMB 232 909 Marina Village Pkwy, Alameda, CA 94501

(510) 532-1786 • Fax 532-3461

[evstarmr@sbcglobal.net](mailto:evstarmr@sbcglobal.net)

### Avoid Rocks, Shoals, 'Land Sharks' & Confiscatory Taxes

We have resolved marine insurance coverage, damage claims, warranty and lien disputes. Experienced in drafting and negotiating purchase/sale, charter, builder's contracts and dealing with the IRS, State and local tax agencies.

A life-long, Bay, coastal, Delta racer/cruiser as well as an Officer/Director and/or Counsel of Yacht Clubs and other maritime entities since 1954. Affiliate of the Society of Accredited Marine Surveyors (SAMS).

## ATLANTIC 57 CATAMARAN™



THE ORIGINAL PILOTHOUSE CATAMARAN

- o Designed for easy shorthanded cruising
- o Spectacular windward performance
- o Cored epoxy/glass/carbon construction

**CHRIS WHITE DESIGNS**

TEL: 508-636-6111

[www.chriswhitedesigns.com](http://www.chriswhitedesigns.com)

## RODGERS & ASSOCIATES



established  
1978

Certified  
Marine Surveyors

As appointed by Boat US Insurance Services  
and Institute of London Underwriters  
ASA - NAMS - LLOYDS

Tel: 831-475-4468  
[rodgers@rodgersandassociates.com](mailto:rodgers@rodgersandassociates.com)

[www.rodgersandassociates.com](http://www.rodgersandassociates.com)

## GOLDEN STATE DIESEL MARINE

PARTS

YANMAR • UNIVERSAL • WESTERBEKE  
PERKINS • ISUZU • PATHFINDER • ATOMIC 4

SERVICE  
DIESEL ENGINES

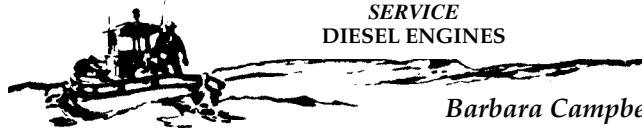

Barbara Campbell

351 EMBARCADERO  
OAKLAND, CA 94606

(510) 465-1093

### ADVERTISER'S INDEX - cont'd

Embroidery Factory.....214	Gentry's Kona Marina .....214	Harken .....40	Kensington Yachts .....222	Mahina Offshore Cruising Seminar .....183
Emery Cove Yacht Harbor.....97	Gianola & Sons .....30	Hays Marine Transport .....215	Kissinger Canvas .....96	Maine Cats .....185
Emeryville Marina .....143	Glacier Bay.....91	Helms Yacht & Ship Brokers/ West Coast Multihulls.....49	KKMI - Bottom Paint.....93	Makela Boatworks .....214
Enviro Lua .....215	Glen Cove Marina .....31	Helmut's Marine Service .....210	KKMI - Brokerage.....79	Marina Bay Yacht Harbor ..147
Essex Credit Corp. ....24	Go Cats.....180	Heritage Yacht Sales .....222	KKMI - Full Service Yard.....51	Marina de la Paz.....212
Fago, Margaret Artist.....31	Golden Gate Yacht Sales .....18	High Performance Sailing Hawaii.....183	KTI Systems/Filter Boss .....101	Marina Puerto Salina.....197
Farallone Yacht Sales.....13	Golden State Diesel Marine.....216	Hogin Sails .....78	Landfall Navigation.....98	Marina Puesta Del Sol .....201
Flying Cloud Yachts .....21	Grand Marina .....2	Hood Sails .....83	Landing School, The .....208	Marina Real .....184
Flying Tiger Yachts .....159	GreenBoatStuff.com .....102	Hotel Coral & Marina.....143	Larsen Sails/Neil Pryde Sails .....62	Marina Riviera Nayarit.....85
Footloose Yacht Charters....178	H&L Marine Woodwork Inc.....91	Hydrovane .....72	Lee Sails .....212	Marina Village.....81
Forespar .....33	H&S Yacht Sales .....14	Jeanneau America.....11	Lifeline Batteries .....96	Marine Engine Co.....208
Fortman Marina.....46	Hanse North America.....45	JK3 Nautical Enterprises .....19	List Marine Enterprises .....104	Marine Lube .....212
Fridge Freeze .....133			Loch Lomond Marina .....198	Marine Outboard Co. ....219
Garhauer Marine.....20				



# NEED CASH FAST?

Advertise your **USED MARINE GEAR**  
in our *Classy Classifieds*

**THIS STUFF SELLS FAST!**

**Deadline is the 18th at 5pm. See page 206 for details.**

## Monterey Bay Marine

at Santa Cruz Harbor

SeaSport • Scout Boats • Livingston

Pacific & EZ Loader Trailers

Yamaha • Honda • Volvo/Penta

[www.montereybaymarine.com](http://www.montereybaymarine.com) 831.479.4595

## RPARTS

REFRIGERATION PARTS SOLUTION

**100% INTERNET BASED** We carry a complete line of refrigeration parts for maintenance, repair, and upgrades for all brands including Grunert, Glacier Bay,

Marine Air, Sea Frost, Adler/Barbour and more. We are also pleased to offer R28+ vacuum insulation panels (independent lab tests) all at Rprices: guaranteed lowest!



[www.rparts.com](http://www.rparts.com)



### ADVERTISER'S INDEX - cont'd

Mariner's General Insurance.....58	Napa Valley Marina .....103	Orange Coast College.....73	Pineapple Sails.....3	Rodgers & Assoc.....216
Maritime Institute.....163	Napa Valley Marina Yachts .....221	Outboard Motor Shop/Star Marine Electronics .....70	Port Townsend Shipwrights Coop.....37	Rooster Sails.....103
Marotta Yachts.....225	Nelson Yachts.....25	Owl Harbor .....202	Prime Fabrication .....210	Ryan's Marine .....208
Mazatlan Marine Center/La Paz Yachts.....10	Nelson's Marine .....228	Oyster Cove Marina.....32	Puerto Lucia.....196	Sail California .....36,38,39
Mc Ginnis Insurance.....147	New Coast Fabrics.....26	Oyster Point Marina .....95	Punta Mita Beachfront Condos.....184	Sail Warehouse, The .....219
McDermot Costa Insurance...37	New Era Yachts .....224	Pacific Coast Canvas.....95	Pusser's Rum .....6	Sailing Supply .....215
McGrath Yachts .....66	New Society Publishers.....82	Pacific Yacht Imports.....9	Quantum Pacific .....41	Sailrite Kits.....86
Milltech Marine Inc. ....64	Norpac Yachts.....227	Paradise Village.....61	Quickline .....215	Sal's Inflatable Services.....101
Moorings, The .....181	North Beach Marine Canvas.75	Passage Yachts .....4,5	R-Parts .....217	S.F. Estuary Project.....22
Modern Sailing Academy ....99	North Sails.....214	Passage Yachts Brokerage..221	Raiatea Carenage Services 200	San Francisco Boat Works..174
Monterey Bay Marine.....217	North Sails - San Francisco ..69	Peter Crane Yacht Sales .....223	Randall Burg Yacht & Ship ...12	San Juan Sailing .....185
Mr. RPM Mobile Welding...214	NorCal January Boat Show..77	Pier 32 Marina/Harbor Island West Marina .....133	Richardson Bay Marina .....28	San Leandro Marina.....23
	Opequimar Marine Center.199			Sausalito Dock-n-Sell.....223
				Scan Marine Equipment.....94





# Society of Accredited Marine Surveyors®

## Serving Northern California

**Al Blair, SA**  
415.456.3154  
blairsurvey@msn.com

**Jesse Brody, SA**  
415.342.0757  
jesse@baymarinesurvey.com

**Alan Huguenot, AMS®**  
415.531.6172  
huguenot@comcast.net

**Tom List, AMS®**  
415.332.5478  
listmarine@yahoo.com

**Jack Mackinnon,**  
**AMS®/SMS**  
510.276.4351  
surveyjack@aol.com

**Francoise Ramsay, SA**  
415.497.7409  
framsay@comcast.net

**Randell Sharpe, AMS®**  
877.337.0706  
rsharpe@alamedanet.net

**Terry Tucker, SA**  
510.381.1925  
ttucker100@sbcglobal.net

**Terry Tupper, SA**  
415.722.7695  
bluwater@juno.com

**Rick Whiting, SA**  
415.740.2924  
captain\_rick@sbcglobal.net

**R.J. Whitfield & Assoc, AMS®**  
800.344.1838  
rjwsurvey.com

### Marine Diesel Specialists AT YOUR SLIP!



30 years experience • Universal/Westerbeke dealers  
Repairs/Tune-ups all models • Engine Surveys, Instruction

**BAY MARINE DIESEL** **510-435-8870**  
**baymarinediesel@comcast.net**

**weatherguy.com**  
Defense Applications and Marine Forecast Service  
*Rick Shema*

970 N. Kalaheo Ave • Suite C-109 • Kailua, Hawaii 96734

Toll Free: (866) 882-WXGY (9949)  
Mobile: (808) 291-WXGY  
Office: (808) 254-2525  
Fax: (808) 254-1525

email: rick@weatherguy.com  
website: www.weatherguy.com

### ADVERTISER'S INDEX - cont'd

Scanmar International.....48	South Beach Harbor.....90	Tartan/C&C Yachts.....15	Vallarta Yachts.....26	Whale Point Marine
Schmidt, Charlotte Yachts...223	South Beach Riggers.....75	The Boatyard at Grand	Vallejo Boat Works.....165	Supply.....50
Schoonmaker Point Marina 162	South Beach Sailing Center .75	Marina.....16	Vallejo Marina.....164	White, Chris Designs.....216
Sea Hawk/New Nautical	Spectra Watermakers.....76	The Cruise Director.....179	Vaughan, William E. ....216	Whitehall Rowing & Sail.....37
Coatings.....56	Staaf Sails.....94	Tim's Zodiac Marine.....97	Ventura Harbor Boatyard....32	Wizard Yachts, Ltd. ....221
Seacoast Marine Finance.....52	Starbuck Canvas.....30	TMM/Tortola	Viking Life-Saving Equipment	Wright Way Designs.....100
Seaportal.....91	Sunsail Charters.....44	Marine Management.....182	.....153	Yacht Racing Assoc. ....105,106
Seashine.....99	Svendsen's Boat Works.....43	Tradewinds Sailing.....142	Voyager Marine.....104	Yachtfinders/Windseekers ...28
Seatech.....212	Svendsen's Boat Works -	Trident Funding.....8	Weatherguy.com.....218	
Seawear Nautical Jewelry...74	Furlers.....203	Twin Rivers Marine Ins. ....100	Wedlock, Ramsay & Whiting	
Selden Mast, Inc. USA.....84	Svendsen's Marine.....68	U.S. Power Squadron	Marine Surveyors.....214	
Society of Accredited Marine	Swedish Marine.....102	District 25.....33	West Marine ..27,29,31,33,80	
Surveyors/SAMS.....218	Switlik.....27	UK-Halsey Sails.....42	Western Grace.....184	
South Bay YRA.....107	Tartan 4400: 'Tartini Time' .222	Ullman Sails.....47	Westwind Precision Details...75	

Don't forget to  
tell 'em that  
*Latitude*  
sent you!

# ELLIOTT BAY YACHT SALES



**51' Able Apogee "Bittersweet"**  
A performance cruising yacht built for an experienced yachtsman—no expense spared!



**65' Perry/Marten "Icon"**  
Stunning all carbon racer/cruiser with a removable cruising interior—a must see!

## SAIL LISTINGS

65' Perry/Marten '01 .....	\$995,000
55' Tayana CC Cutter '91 ....	\$355,900
51' Able Apogee '95 .....	\$480,000
50' Celestial Pilothouse '96..	\$329,000
48' Oyster '90 .....	\$349,000
47' Grand Soleil 46.3 '98 ...	\$295,000
40' Alden '55 .....	\$39,550
39' Baltic '78 .....	\$124,950
36' Cape George '80 .....	\$105,000
36' Union Cutter '80 .....	\$78,000
35' Catalina C350 '04 .....	\$149,000
30' Yamaha '80 .....	\$42,500
22' Cornish Shrimper '86 .....	\$21,500

## ELLIOTT BAY Yacht Sales

Elliott Bay Marina  
2601 West Marina Place, Suite D  
Seattle, Washington 98199

Phone: 206.285.9563  
Email: info@elliottbayyachtsales.com  
Web: www.elliottbayyachtsales.com

**FAST SHIPPING!**

**NEW AND USED SAILS!**

Specializing in production boats and featuring the largest selection of stock sails available anywhere! Save with warehouse volume discounts on Stock Sails, Custom Sails, Sail Covers, Furlers and Accessories. All top Quality.

**All Fully Guaranteed!**

- Full Batten Mains
- Furling Genoa's
- Storm Jibs
- Trysails
- Furling Units
- Custom Canvas
- Used Sails

**FREE CATALOG!!**

**THE SAIL WAREHOUSE**

Ph. (831) 646-5346    www.thesailwarehouse.com

**SMILE**

*Latitude 38 Photo Boat Crossing!*

**EXCELLENCE IN MARINE EQUIPMENT**

**2007 NISSAN OUTBOARDS**

NSF 3.5 AI	3.5 hp 15"	\$962
NSF 8A31	8 hp 15"	\$1,664
NSF 15B21	15 hp 15"	\$2,200

**TLDI TWO STROKE ENGINES**

NSD 90BEPT02	90 hp 20" fuel injected	\$7,544
NSF 115AEPT02	115 hp 20" fuel injected	\$8,300

*Controls & 3-year warranty included. 20% off product and/or labor to veterans.*

*Now offering 14.5' hand-layed ocean kayaks.*

265 Gate 5 Road • Sausalito, CA 94966    (415) 332-8020

**Donate your Boat**

**Cars, Trucks, RVs, & Real Estate**

*We handle all DMV & Smog*

*Running or Not (restrictions apply)*      **Tax Deduction**

**BLUEWATER NETWORK** | **800-324-7432**

*"Proceeds help Bluewater Network reduce greenhouse gases, clean up our air and water, and protect marine mammals and wildlife."*





## Sail into the New Year

**Cruising World Pacific, Inc.**

1853 Embarcadero, 2nd Floor, Oakland, CA 94606

**(510) 764-1734**

[www.YachtCouncil.com/cwp](http://www.YachtCouncil.com/cwp)



DESCRIPTION		24/7 ext.	DESCRIPTION		24/7 ext.
52' Tayana CC Cutter	1991	\$295,000	37' Endeavour sloop	1978	\$55,000
50' Hudson Force 50 Ketch	1974	\$109,900	36' Catalina MkII	2000	\$114,900
47' Beneteau 47.7	2001	\$330,000	36' Catalina MkII	1999	\$113,900
44' Peterson cutter	1978	\$114,000	36' Catalina sloop	1984	\$55,000
41' Hunter 410	2004	\$224,900	36' Columbia sloop	1968	\$29,900
40' Islander Peterson	1981	\$59,900	34' Cal Pearson	1976	\$29,500
39' O'Day sloop	1983	\$69,000	34' Catalina MkII	2005	\$129,000
38' Morgan 382	1980	\$59,000	34' Pacific Seacraft	1989	\$119,900
38' Baltic Doug Peterson	1984	\$128,000	33' Nor'West 33.5	1982	\$39,500
38' Ericson sloop	1981	\$46,900	32' Capital Gulf	1985	\$49,995
38' Hans Christian	1976	\$59,900	32' Fuji cutter	1977	\$49,900
38' Tripp Javelin	1961	\$34,500	25' Pacific Seacraft sloop	1976	\$18,900
					7123
					7133
					7143
					7153
					7163
					7173
					7183
					7193
					7203
					7213
					7223
					7233

**You can receive a boat info sheet via our 24/7 Auto Fax Back  
Call (888) 827-1891 then dial extension**

### HUNTER 340, 1999

Raymarine, StackPac  
main, dinghy & more.

Auto Fax Back  
(888) 827-1891  
ext. 3453



### STEVENS 50, 1986

Heat, AC, genset.  
Completely cruise  
equipped.

Auto Fax Back  
(888) 827-1891  
ext. 3213



### NOR'WEST 33

Offshore cruiser.  
New rigging,  
Monitor windvane.

Auto Fax Back  
(888) 827-1891  
ext. 7203



# DONATE YOUR BOAT

to the Aquatic Protection Agency. We protect our precious coastal waters from illegal toxic pollution. We can use your equipment, so you will get maximum value for your donation.

We are on the water, monitoring cruise ships, performing BlueBoater trainings, and testing outfalls for harmful toxins.

**Call (415) 235-0756**

**or (831) 247-8228**

**or email**

**[boats@aquaticprotection.org](mailto:boats@aquaticprotection.org)**

**[www.AquaticProtection.org](http://www.AquaticProtection.org)**



# GO FASTER *Wizard* YACHTS LTD.

Bill Lee  
Dan O'Brien  
Tom Carter



345 Lake Ave., Suite G  
Santa Cruz, CA 95062  
(831) 476-9639 fax (831) 476-0141  
[www.fastisfun.com](http://www.fastisfun.com)



**MERLIN, 68' CANTING KEEL** racing yacht. Carbon mast, all new everything. Fast is really fun. **\$295,000**



**OPEN 50 'Tuesday's Child'** Extensive upgrades. Real interior including V-berth. Water ballast. Inboard diesel. **\$89,000**



**SANTA CRUZ 50** Go fast and have fun. Recent mast, sails and scoop. **\$179,000**



**CATANA 411 CATAMARAN** Twin diesels, four staterooms, daggerboards for good upwind performance. Lying Ecuador. **\$239,000**



**CAL 31** Pocket cruiser. Diesel, excellent condition, one year Santa Cruz slip possible. **\$26,500**



**CATALINA 30, 1987** Lightly used, diesel, tabernacle mast, one year slip at Santa Cruz possible. Great boat. **\$24,500**

## 56' FOUNTAINE PAJOT MARQUISES

2001  
**\$895,000**



Most spectacular salon of any yacht in its class. Panoramic views and rich cherry joinery throughout. Large galley complete with bar and built-in seats; wrap-around dinette accommodates 10. Impressive navigation center with all the latest electronics.

Entire starboard hull dedicated to the captain's stateroom. Two large staterooms with their own private heads to port, with additional crew quarters. More than 1,000 sq. ft. of deck space. Low hours on twin Yanmar 75hp direct drive diesel engines.

Never chartered, hardly used. This vessel will take you anywhere in the world and is only limited by your imagination.

**NAPA VALLEY MARINA YACHTS**

**(866) 363-8882 • (707) 252-8011**

## THREE MONTHS FREE BERTHING FOR QUALIFIED NEW LISTINGS



**ISLAND PACKET 380, 2001 ~ \$235,500**



**BENETEAU IDYLLE 11.5  
1985 ~ \$69,000**



**CATALINA 30, 1995  
1995 ~ \$54,500**



**BENETEAU 473, 2004 ~ \$274,900**



**HUNTER 386, 2004 ~ \$159,500**



**HUNTER 310, 1997 ~ \$52,800**



**HUNTER LEGEND 40.5 ~ \$119,000**



**NEW ALAMEDA OFFICE**  
1070 MARINA VILLAGE PKWY, STE 101  
ALAMEDA, CA 94501  
**(510) 864-3000**

**PT. RICHMOND OFFICE**  
1220 BRICKYARD COVE RD.  
PT. RICHMOND, CA 94801  
**(510) 236-2633**

[www.passageyachts.com](http://www.passageyachts.com)  
[sales@passageyachts.com](mailto:sales@passageyachts.com)



# HERITAGE

Yacht Sales

*Live your Dreams*



47' Passport AC  
2002  
\$480,000



40' Beneteau  
Oceanis  
1996  
\$115,000



37' Cal  
1966  
\$89,900



36' Pearson 36-2  
1986  
\$70,500



33' Hunter 336  
1996  
\$66,500



25' Catalina  
2006  
\$31,500



## Slips available!

Long Beach-Naples	231 North Marina Dr. 866-56-YACHT
Newport Beach	829 Harbor Island Dr. 877-38-YACHT
Wilmington	Berth 202 Peninsula Rd. 877-59-YACHT

Full specs at [www.heritageyachts.com](http://www.heritageyachts.com)



## Kensington Yachts

*"Everyone needs a bigger boat"*

### UNIQUE, REDUCED COMMISSIONS!

*Our commission structure is on a sliding scale.*

- Have a large note?
- Two boat owner?
- Death or family emergency?
- Want to trade up?

*We have seen every situation, and understand.*

**Call us today. Let us help you sell your boat!**



BRISTOL 47.7 CC, 1992...\$399,000



43' MORGAN CENTER COCKPIT, 1985...\$122,500



37' WAUQUIEZ, 1971...\$49,000



34' CANADIAN SAILCRAFT CS, 1990...\$63,000

#### SAIL

41' COOPER 416, 1981 .....\$95,000  
37' CHEOY LEE PRINCESS, 1958 .....\$22,000  
36' FREEDOM YACHTS SLOOP, 1986.....SOLD  
36' S-2 CENTER COCKPIT, 1984.....SOLD

30' CATALINA, 1980.....\$23,500

#### POWER

40' BAYLINER 4087, 1996.....\$169,000  
28' BAYLINER TROPHY 2802, 2001 Santa Cruz Slip

## Kensington Yacht & Ship Brokers

email: [yachts@kensingtonyachts.com](mailto:yachts@kensingtonyachts.com)

**877.444.5272 • 415.793.9376**

[www.kensingtonyachts.com](http://www.kensingtonyachts.com)

## TARTAN 4400: TARTINI TIME



- Hull #1 of of Tartan's newest Deck Salon
- Electric winches
- Full batten main, roller genoa, cruising spinnaker
- Espar central heat
- Kato davits (not shown) with Caribe inflatable
- Only 140 hours on diesel engine

*Call for full details and other features & options*

**(530) 318-0730**

[amgjohn@sbcglobal.net](mailto:amgjohn@sbcglobal.net)

# Sausalito DOCK-n-SELL

Dock your yacht where it will be seen  
by buyers in downtown Sausalito.  
No brokers/salesmen commissions.  
**Save thousands!**

**Complete Yacht Services**  
Detailing - Electrical - Heads  
Surveys - Title Search  
Sea Trials - Financing - Comps

'For Sale by Owner' is not a new concept, we just made it easier and more cost-effective. Your yacht will be ready to show 24/7 by appointment with pre-qualified buyers. No more wasting time with tire kickers. Space is limited, so call today for details – you will be pleasantly surprised!

**Trailerable Boats Welcome!**

**"HOLD ON TIGHT TO YOUR DREAMS!"**

**HAPPY NEW YEAR from  
Sausalito DOCK-n-SELL!!**

**Sausalito DOCK-n-SELL**

41 Liberty Ship Way, Sausalito  
behind the Bay Model

**415.686.6860**

## Peter Crane Yacht Sales and Charters

In Santa Barbara - experienced, interested, friendly, low pressure  
Brokerage without walls

Peter Crane (805) 963-8000

Mark Scott-Paine (805) 455-7086



**1975 C&C 38**  
hard dodger, circumnav vet  
new shaft, prop \$45,000



**1978 Holcomb 38' schooner**  
bronze fastened work of art  
handcrafted top to bottom \$75,000



**1958 Bounty II yawl**  
well restored, excl. paint, decks  
new diesel, good sails \$39,000



**1992 Gulet 88 motorsailer**  
beautiful condition, new cat engine  
6 cabins ea w/ head, shower + crew  
\$850,000



**1974 Formosa 51 pilothouse**  
recent major refit for world cruise  
change in plans forces sale \$138K



**1981 Herreschoff Nereia 36**  
traditional good looks in fiberglass  
well equipped to cruise \$89,500

Info and photos: [www.petercraneyachts.com](http://www.petercraneyachts.com)

[pc@petercraneyachts.com](mailto:pc@petercraneyachts.com)

**Santa Barbara Slip Specialists**

## CHARLOTTE SCHMIDT

YACHT SALES

*When Experience Counts*

4100A Harbor Blvd.  
Oxnard, CA 93035  
Fax (805) 382-2374

In SF Bay Area: (415) 613-0712

**(805) 382-2375**

Csyachtsales@cs.com

[www.yachtworld.com/charlotteschmidt](http://www.yachtworld.com/charlotteschmidt)



**51' CHB PILOTHOUSE LRC, 1978** Twin Ford  
Lehmans, full flybridge, dual steering, 2 state-  
rooms, washer/dryer, pilothouse with dinette &  
berth, strong offshore cruiser, rare offering, great  
price. Call Listing Agent Gary (415) 613-0712.



**46' BENETEAU OCEANIS 461, 1997**  
Yanmar 78hp diesel, genset, watermaker,  
dodger, beautiful interior, well maintained,  
fully equipped for offshore cruising.  
Must see. Asking **\$189,500**



**34' CATALINA, 1988**  
Universal diesel, autopilot, GPS, dodger,  
furling jib, Caribe dinghy w/outboard, clean  
and ready to sail. Asking **\$53,900**



**51' COOPER PILOTHOUSE, 1982**  
Lehman 80hp diesel, chartplotter, GPS,  
radar, three staterooms, good interior layout,  
excellent offshore cruiser. Asking **\$174,900**



**34' GEMINI 105M CATAMARAN, 1997**  
Many great features, Westerbeke diesel,  
autopilot, chartplotter, furling jib, excellent  
condition! Asking **\$115,000**. Contact owners'  
listing agent Gary Kaplan at (415) 613-0712.



**47' VAGABOND KETCH, 1986** Ford Lehman  
diesel, genset, chart plotter, radar '06, AP '06,  
SSB, 12' Avon, dodger. Stunning condition. Top  
condition. You won't find a better Vagabond. At  
our docks. Asking **\$239,000**



# CABRILLO YACHT SALES

"Discover The Difference"

(619) 523-1745

[www.cabrilloyachts.com](http://www.cabrilloyachts.com)

Sun Harbor Marina (next to Fisherman's Landing)  
5060 N. Harbor Drive, Suite #155, San Diego, CA 92106

## tayana yachts sales/service



Custom Construction

64' TAYANA, 2008

- 200 hp diesel
- 650 fuel
- Electric windlass/winch
- 3-4 cabins

All New  
72' Deck Salon  
Bill Dixon design



2008

72' TAYANA DYNASTY  
Bill Dixon/Andrew Winch design.  
Design/priced affordably.



2008

48' TAYANA DECK SALON  
Center cockpit or pilothouse models.  
Also a used 48', 55' & 46' PH



Tayana

ALL NEW BILL DIXON DESIGNED  
54' TAYANA  
Check it out.



Used Tayanas

TWO 55' TAYANAS  
Ready to take on your wildest cruising dreams.  
Plus used 42'.



N DOCK

42' BALTIC by CENMARINE  
High quality performance cruiser.  
Swan-like qualities.



Price Reduced

45' DOWNEASTER KETCH  
Location: Hawaii. Slip obtainable with credit  
check. Make offer today. Also: 38' available.



New to Market

55' ISLANDER  
Tradwinds Model. She is a famous  
circumnavigator ready to go again.



Price Reduced

38' VAGABOND WESTWIND Many  
custom features. Super clean, cruise ready.  
\$119,900. And 42' Cenmarine/Baltic.



Price Reduced

51' SPENCER  
Canadian built quality.  
Has a lot of potential.



SOLD

MORGAN/CATALINA 440  
"No worries" says it all. Under factory warranty.  
Also: 42' Catalina, 2002



New to Market

70' OCEAN ALEXANDER LRC  
Beautiful joinery. Well cared for.  
Also: 44' available.



Recreational

TWO 34' HUNTERS  
and a 30' CATALINA.  
Great boats for the \$\$.

Worldwide / Mexico / Pacific Coast

Tayana Yachts • Large Selection of Used Yachts

[www.cabrilloyachts.com](http://www.cabrilloyachts.com)

Mexico Connection Keith Demott (520) 743-7833

# NEW ERA yachts

POWER & SAIL



51' BENETEAU, 1986 • \$159,000



47' VAGABOND, 1981 • \$165,000



43' HANS CHRISTIAN, 1999 • \$139,000



36' CATALINA, 1985 • \$55,000



36' CHEOY LEE, 1986 • \$59,000



35' MORGAN, 1970 • \$24,500



32' HUNTER VISION, 1990 • \$37,500



31' HUNTER, 2 to choose from \$28,500

Visit our new office in Grand Marina  
2021 Alaska Packer Place, Alameda, CA 94501  
sales@newerayachts.com  
**(510) 523-5988 • www.newerayachts.com**

## Give A Little...

Now Accepting  
Automobiles!



## Give A Yacht...

Your generosity will give your boat a new home and  
give you a nice tax break and great satisfaction...

Our growing Scout program needs your support:

- Any serviceable vessel can be used.
- We'll make the transfer quick and easy.
- Tax benefits from donating can meet and sometimes even exceed the amount realized from selling your vessel.
- You can eliminate the bills associated with the cost of owning your boat.

Donations  
Are Tax  
Deductible



Donate Your Boat to the Sea Scouts

San Francisco Bay Area Council,  
Boy Scouts of America

For more information contact: Matt Myers  
1-800-231-7963 x145 • mattm@sfbac.org



# Marotta Yachts of Sausalito

Brokers of Fine Sail and Motor Yachts

415-331-6200 • [info@marottayachts.com](mailto:info@marottayachts.com)



See at:  
[www.marottayachts.com](http://www.marottayachts.com)

### 46' WATERLINE CUTTER, 1999

This beautiful steel cruising cutter is well equipped (almost \$100,000 of electronics, as well as genset, central air, electric winches, watermaker, washer/dryer, etc., etc., etc.), highly customized with a \$225,000 refit in '04-'05, and shows bristol inside and out.

\$499,000



See at:  
[www.marottayachts.com](http://www.marottayachts.com)

### 47' JEANNEAU SUN ODYSSEY, 1992

Sexy Euro-style performance cruiser with deep draft Kevlar-reinforced hull & nicely laid out, spacious 3-stateroom interior. Well equipped with offshore dodger, full suite of electronics, new Doyle sails, heavy duty ground tackle and 10' Caribe RIB on nicely executed stainless steel davit system.

\$230,000



See at:  
[www.marottayachts.com](http://www.marottayachts.com)

### 40' NEWPORT CENTER COCKPIT, 1987

Partial list of recent work includes all new sails, refinished boom, new ProFurl roller furler, new winches and mainsheet, all new electronics, rebuilt engine, new fuel tank, new batteries and charger, extensively replumbed, new canvas and isinglass, much more. Vessel shows very nicely and is lying in a transferable Sausalito slip.

\$125,000



See at:  
[www.marottayachts.com](http://www.marottayachts.com)

### 42' CHEOY LEE GOLDEN WAVE, 1984

Designed by Bob Perry to look like a Swan topside and a Valiant 40 below. Never cruised, she shows nicely – sails in fine shape, low time on the trusty Perkins 4-108 diesel, heavy duty stainless steel, dinghy, davits/radar arch, electric windlass, radar, etc.

\$94,000



See at:  
[www.marottayachts.com](http://www.marottayachts.com)

### 39' COLUMBIA CENTER COCKPIT, 1979

Alan Payne-designed classic yacht has essentially been completely rebuilt and with over \$30,000 spent since '02 now shows better than new: rebuilt engine, new mainsails, renewed rigging, replumbed, rewired, replaced original plastic portholes with ABI stainless steel, new custom hard dodger, etc., etc., etc.

\$89,000



See at:  
[www.marottayachts.com](http://www.marottayachts.com)

### 40' HUNTER LEGEND, 1987

6'5" headroom throughout, QUEEN berth aft, plus a roomy cockpit and well-designed plan topsides – it's a hard-to-beat package (especially at a price well below \$100,000!). Clean, low engine time and transferable Sausalito slip.

\$69,000



See at:  
[www.marottayachts.com](http://www.marottayachts.com)

### 36' SWALLOWCRAFT SCYLLA KETCH, 1979

Very nice aft cockpit motorsailer built in Korea to European quality standards. New listing, additional information available soon.

\$54,900



See at:  
[www.marottayachts.com](http://www.marottayachts.com)

### 35' PEARSON, 1981

Bill Shaw-designed classic in fine shape, just detailed and lying in a transferable Sausalito slip.

New listing, full story online at [www.marottayachts.com](http://www.marottayachts.com).

\$34,800



See at:  
[www.marottayachts.com](http://www.marottayachts.com)

### 30' HUNTER, 1979

The Hunter 30s all have attractive lines and a spacious interior, and this particular boat shows nicely inside and out with the topsides looking especially nice for her age. Note Yanmar diesel; most boats in this price range have gas engines.

\$16,500

100 BAY STREET • SAUSALITO • CALIFORNIA 94965





**35' HANSE 350, 2008**  
Available at the San Rafael sales dock.

# Anchorage Brokers & Consultants YACHTS



www.yachtworld.com/anchoragebrokers  
#1 Gate 5 Road, Sausalito, CA 94965

**(415) 332-7245**  
yachts@abcyachts.net

*Happy  
New Year!*

25 Third Street,  
San Rafael, CA 94901

**(415) 457-9772**

*Hanse*

CLAY & TERESA PRESCOTT • GEORGE HIGBIE • PHIL HOWE • GEORGE SCOTT • LARRY MAYNE • DANA PAUL • ARNIE GALLEGOS • PETER BOHN • ED LABARRE • JOHN SAUL



**PASSPORT 37, 1986** Robert Perry design, second owner, newer sails in 2003, Pullman berth, beautiful teak interior. **\$109,000**



**TWO  
BENETEAUS**

**BENETEAU 411, 1999**, tri-cabin.  
**34' BENETEAU 350, 1988**, bristol, **\$67,000 (pictured)**



**35' J/105**  
One owner, racing and cruising sails. **\$105,000**



**36' ISLANDER FREEPORT, 1978**  
Bob Perry hit the nail on the head when he designed this one! **\$61,900**



**PEARSON 37, 1982**  
Clean, newer rigging and sails. **\$49,000**



**HUNTERS**

**40' HUNTER 40.5, 1995, \$116,000**  
**35' HUNTER 35.5, 1993, \$69,000**  
**33' HUNTER, 2005, Bank Repo**  
**33' HUNTER, 2004, \$93,000**  
**33' HUNTER 33.5, 1992, \$57,500**  
**29.5' HUNTER, 1994, \$40,000 (pictured)**



**36' SWEDEN, 1984**  
Swedish-made, performance plus, beautiful teak joinery below. 2 staterooms. **\$75,000**



**NORSEMAN 447 CENTER COCKPIT, 1984**  
Newer engine, low hours genset, newer rig and sail. **\$225,000**  
Also: **NORSEMAN 535, \$549,000**

SAIL		POWER	
53' Norseman 535	'88 549,000	33' Hunter 33.5	'92 57,500
52' Hartog schooner	'99 195,000	33' Mason	'87 99,500
50' Gulfstar sloop	'78 Inquire	33' Newport	'84 34,500
49' Reliant Ketch	'91 135,000	32' Westsail	'77 52,500
47.7' Bristol CC	'92 399,000	32' Fuji ketch	'76 37,500
47' Jeanneau Sun Odyssey	'92 230,000	31' Pacific Seacraft Mariah	'79 69,000
46' Chesapeake	'98 77,000	30' Catalina, new engine	'75 16,500
47' Perry cutter	'80 115,000	30' Islander	'75 15,000
45' Bruce Roberts CC	'79 120,000	30' Lancer	'80 36,000
44' Hylas	'86 185,000	30' Hunter	'90 36,000
44' Norseman CC	'84 225,000	29' Hunter 29.5	'94 40,000
43' Hans Christian	'82 129,000	28' Newport	'79 9,500
42' Baltic DP	'84 189,000	28' Pearson Triton	'61 11,000
41' CT	'76 79,000	27' Pacific Seacraft	'80 54,000
40' Cheoy Lee MS	'75 73,900	67' Stephens Alum	'80 895,000
40' Olson	'83 69,500	65' Pacemaker, cert.	'71 299,000
40' O'Day	'86 75,000	65' Elco Classic MY	'26 450,000
40' Hunter 40.5	'95 116,000	57' Chris Craft	'65 135,000
40' Challenger	'73 73,000	53' Hatteras MY, new engines	'76 259,000
39' Cal, nice	'79 74,900	50' Stephens	'65 135,000
39' Freya	'81 109,500	45' Chris Craft	'73 149,000
38' Ingrid	'76 & '84 from 61,900	44' Defever	'82 235,000
38' Hans Christian	'80 99,000	44' Gulfstar MV	'79 147,000
37' Pearson	'82 49,000	43' Viking DC	'77 107,000
37' Alberg, equipped	'72 90,000	41' Hatteras	'61 Inquire
37' Rafiki, new engine '07	'77 67,000	41' Hatteras, nice	'65 149,000
37' Irwin	'79 40,000	40' Sea Ray Sundancer, diesel	'97 197,000
36' Pearson 365, Bristol	'81 70,000	38' Holiday Mansion	'89 38,500
36' Islander	'77 & '74 from 42,000	38' Fu Hwa	'84 125,000
36' Islander Freeport	'78 61,900	38' Bayliner, nice	'90 97,000
36' Catalina	'84 & '93 from 59,500	35' Cooper Prowler	'86 78,000
36' Sweden	'84 75,000	34' Mainship	'81 48,000
35' Fantasia	'79 50,000	34' Sea Ray Sundancer	'01 169,000
35' Hanse	'08 Inquire	34' Kevlacat	'97 160,000
35' Hunter 35.5	'93 69,000	32' Uniflite, t/d	'77 37,500
35' Beneteau Oceanis 350	'88 75,000	32' Silverton FB, 370 hrs	'98 49,000
35' Baba	'79 77,500	30' Sea Ray 305 DB	'88 59,900
35' Ericson, nice	'79 33,000	27' Pacemaker	'78 15,000
34' Hanse 341	'03 139,500	26' Osprey long cabin	'03 85,000
34' C&C	'80 37,500	26' Osprey	'02 98,000
34' Sabre	'83 49,000	24' Chaparral, trailer	'94 19,000
34' J/105	'99 105,000	24' Orca, inboard	'99 59,950
33' Hunter	'04 93,000	24' Osprey	'96 69,500
33' Hunter	'05 Repo	22' Grady White 222 w/trlr	'02 59,000



**47' JEANNEAU SUN ODYSSEY, 1992** 3 staterooms, master is Pullman, upgraded beautiful interior, RF main, 75hp Yanmar. Worth seeing! **\$230,000**



**40' CHALLENGER**  
Super clean! Complete refit, new paint from mast to keel. **\$73,000**



**47' PERRY CUTTER CC, 1980**  
*Anything She Wants.* South Beach SF. New tanks, 6 cyl. Ford Lehman. **\$115,000**



**BOTH  
REDUCED**

*Pictured:* **HANS CHRISTIAN 43, 1982**  
New engine, genset, cruising electronics, great price. **\$129,000**  
Also: **HANS CHRISTIAN 38, 1980, \$99,000**

## Hanse Dealer Report

Three new Hanses on the Bay:  
350, 370e, 540e

Larry R. Mayne  
Yacht & Ship Broker  
Dealer & New Boat Sales Manager

Sales dock slip available, \$300/month



Latest arrival, the big 540  
with all the trimmings!  
*Happy New Year!*

# NORPAC YACHTS

On  
Hwy 101

557 Francisco Blvd., San Rafael, CA 94901

(415) 485-6044 • FAX (415) 485-0335

email: info @ norpacyachts.com

**WE HAVE BUYERS & NEED MORE BOATS!  
LIST YOUR BOAT NOW & WE SHALL SELL HER!**

FOR MORE  
SEE OUR

[norpacyachts.com](http://norpacyachts.com)

WEBSITE

AWESOME

**100' MEGA SLOOP** Custom Offshore Performance Cruiser. Luxurious, spacious, comfortable, sleeps 25 in 17 bunks. Loaded w/amenities & equipment. Fast, Cummins dsl. Excellent condition. Great private yacht with super charter potential. World class cruising and MORE! **\$1,500,000 Ask**

HIGH ENDURANCE CRUISING YACHT

**75' NORTH SEA TRWLR.** Awesome Blue Water World Cruiser. Massively built in SCOTLAND to go to sea & stay. CAPE HORN Vet. Impeccable total refit & conversion. Fully found/loaded. Strong, economical & long lasting Gardner dsl. **\$825,000**



**66' THORNYCROFT CUTTER-RIGGED KETCH** Classic 1923 design, well maintained. She's like a beautiful & comfortable private British club down below. Must be seen. Teak decks, diesel, genset, radar and more. Extremely charming and a great performer. **Asking \$174,950**



**57' CHINESE JUNK.** Teak const. Huge & very comfortable well lit & well appointed inter. Outstanding liveboard cruiser w/lug rig & highly desirable Gardner dsl. Charm, character. Gen set, washer/dryer. Pos. liveboard slip & more! **\$149,000/Offer**



**30' RINKER 300** Fiesta Vee Express, '94 w/near zero hrs on full inside/out remanufacture/refit incl. her twin engines. Aft cabin, quality, comfort, condition & performance. **Ask \$32,988**



**40' CHEOY LEE GULF 40 PH Sloop.** 56hp Yanmar diesel, varnished teak hull, copper rivet fastened. Good sail inventory including 2 spinnakers, AP, radar, chart/GPS, more! Great yacht in great shape. **Asking \$55,000**

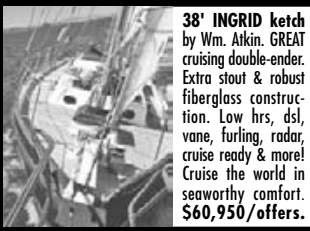

**38' INGRID ketch** by Wm. Aikin. GREAT cruising double-ender. Extra stout & robust fiberglass construction. Low hrs, dsl, vane, furling, radar, cruise ready & more! Cruise the world in seaworthy comfort. **\$60,950/offers.**



**45' COLUMBIA** Center cockpit Slip. Dsl, F/G, roomy, comfortable cruiser with good light and visibility below. Two heads, shower & MORE! These are great cruise/live vessels. We have two, starting at **\$39,750.**



**30' BRISTOL 29.9.** Famous Halsey HERRESHOFF cruiser/racer. Dsl, extra robust FG construction, roller furling, roomy & comfortable, dodger, pedestal wheel steering & more! This is a great boat. **Ask \$34,950**



**42' SPARKMAN & STEPHENS Slip.** F/G, dsl engine, spinn., dodger, major refit incl. rig. Beautiful cruiser from world-class architect; she's a very desirable yacht with a great layout, excellent performance & outstanding comfort and cond. Hard to go wrong. **Asking \$49,000**

**SAIL**  
51' FORMOSA Ketch. Aft cockpit. Good project. Fiberglass, diesel & lots of extras.....\$4,950/Offer  
50' CAULKINS Slip. A project, but all there. Dsl, strip plank, ocean racer. Try 15,000  
45' COLUMBIA CENTER COCKPIT Sloop, diesel, fiberglass, roomy, comfortable cruiser with good light and visibility down below, 2 heads, shower & more. These are well respected for cruising & for living aboard. We have two, starting at ..39,750 Ask  
42' SPARKMAN & STEPHENS steel custom cutter by Olin Stephens. Cent. cockpit, aft cabin, dsl & more... Asking 60,950  
41' HINCKLEY Cr. Trad. beauty and a world-class builder.....Ask 69,900  
39' FREYA Double-ender, steel, dsl, dink+o/b, new paint, solar, furling, RADAR, AP, cruise equipped + more! ... 62,950  
38' KETTENBURG Sloop. Dsl... Ask 43,950  
37' GULFSTAR cent. cockpit, aft cabin, dodger, dsl & more..... 43,950  
37' VILLENAVE Cruising Cr. Blue Water Euro Performance. Loaded..... Ask 43,950  
36' ISLANDER Sloop. Major upgrades, dsl, dodger, furling & more..... Ask 44,950  
36' STEEL HARTOG ketch, double-endered cruiser. Great potential and a great value priced at .....Offers/16,950  
36' NIELSEN classic 1918 Danish aux. sloop. Nice condition..... Asking 15,000  
35' CHEOY LEE by Robb. Dsl, teak... 17,950  
34' COLUMBIA Slip. Dsl, furling ++ .. 9,450  
30' NEWPORT Slip, 1/B, A/P, F/G... 11,950  
30' CATALINA Sloop. Furling, dodger, diesel, wheel steering, Avon, EXTRA CLEAN & More! ..... Ask 24,950  
29' PEARSON TRITON. New diesel. Total refit nearly done..... Asking 15,950  
28' MORGAN Out-Island Slip, 1/B, shower & more! A Great Boat at a Great Price! ..... Ask 8,500  
26' INT'L FOLKBOAT, F/G, O/B... Ask 6,950  
25' CHEOY LEE FRISCO FLYER, teak... 8,000  
23' HERRESHOFF Classic PRUDENCE Slip w/'03 Honda ..... 7,500

**POWER**  
130' CAMCRAFT Passenger Ship. Certified for 33 passengers overnight. Booked for the season. Virtual turnkey: SS and opportunity.....2,200,000  
63' FERRY conversion, 671 diesel, 19.5' beam, excellent condition. Ask 28,000  
60' MATTHEWS MY, '65, twin diesels, big, comfortable liveboard cruiser w/South SF berth..... Asking 215,000  
45' STEPHENS 1929 classic. Beautiful Gatsby-Era Motoryacht waiting to transport you back to the days of yachting in the grand style..... Try 75,000  
43' MATTHEWS, '65, diesel. A gem! Loaded and beautiful..... Ask 69,450  
42' GRAND BANKS Twl. Aft cabin, F/G, Onan, twin dsls, RADAR. Excellent... 121,000

41' CHRIS-CRAFT CONSTELLATION. Aft cabin. Great liveboard, full Delta canvas, good condition. 37,500/Offer  
40' OWENS, '65 Tahitian. Great for cruise/live, comfort, room & NICE! Newly refinished ..... 19,988 Asking  
37' HATTERAS Convertible. One of their BEST EVER! Maj. refit just complete. Twin 8V53 Dsls, 7.5 kw Onan, F/B. Loaded & outstanding. 179,000/Offer  
37' DE FEVER TRAWLER by North Sea. Dsl, F/G, F/B, 2 heads, showers, RADAR, gen., thruster, GPS/map & MORE! Very nice..... 88,950 Asking  
36' UNIFLITE. F/B, aft cabin, twins, radar, GPS and more!..... Asking 59,950  
36' CHRIS CRAFT Express Cruiser, twins, runs well. BARGAIN!..... Offers/6,850  
35' CHRIS CRAFT CAVALIER. Aft cabin, flybridge, twin V8s, many recent upgrades. Very nice. Reduced! EXCELLENT BARGAIN ..... 8,950  
34' CHB Mainship Twl. by Silverton. 160 hp dsl. F/G, gen & more! 49,500/Offer  
32' ROBERTS commercial fish w/HERRING PERMIT & more!..... Asking 58,950  
32' CARVER. Glass, twins, Sausalito live-aboard berth. Nice! ..... Asking 30,950

32' BOWPICKER, aluminum. Commercial (herring) license..... 49,000  
31' MONTEREY BAY EXPRESS PH utility, F/G, 1991, twin 130 Yanmars, trailer, USCG-documented, commercial quality gem..... Reduced! Asking 34,950  
30' WILLARD Trawler, dsl ++ .. Ask 34,950  
29' WELLCRAFT 2900 EXPRESS. Twin screw (not outdrives). Super clean & nice! Bright red...REDUCED! Asking 19,950  
28' RODMAN WA, F/B, 2004. Twin dsls, high quality & loaded. Looks new!..... Reduced! 149,000  
27' FARALLON Pilothouse, F/G, twin 5LVBs, fast & seaworthy. Just detailed & very nice 1986..... Ask 51,950  
26' PACEMAKER, cab. cruise w/V8, nice!..... Ask 8,500  
26' BARTENDER by Caulkins. Capable double-ender, V-8..... Ask 11,950  
25' FARALLON SF w/trailer. New twin 180 hp Volvos, radar, etc.... Asking 22,450  
24' SEA RAY V8. Full Delta canvas, trl, o/d, nice!..... Ask 12,000  
21' SEA RAY Cuddy, 1/O, Kicker, Trailer. Extra nice & MORE! ..... 9,950  
**OTHER**  
56' LCN-6 with dive support, steel, W/H, twin 671s, full elect..... Try 25,000

**SPECIALIZING IN  
VESSEL INCORPORATION  
&  
OFFSHORE REGISTRATION**

Many Advantages

Call: Glenn Shelly, MBA

The Broker: NORPAC

Direct cell: (415) 637-1181

Direct email: [glenn@norpacyachts.com](mailto:glenn@norpacyachts.com)



CLASSIC CRUISER

**65' CLASSIC, '31 MOTORYACHT BY WHEELER.** 16' beam, recent 40k hull refurb. Bottom's good & she's ready for you to finish restoration. Pilothouse, twins, 3 heads, huge salon, crew's quarters and more. **\$49,950/Offer**



**32' FUJI KETCH.** Diesel, furling, shower, full galley, full cruising keel with cutaway forefoot. Very nicely maintained ++. We have two starting at **\$31,950 Ask.**



GRAND BANKS

**32' GRAND BANKS CLASSIC TRAWLER.** 1970 Economical diesel, dual helms, flybridge, TEAK decks, full electronics, swim platform, mast and boom. She's a great cruiser and a very well loved design. **\$34,450/Offer**

**The OLD KERMIT PARKER BROKERAGE  
Serving the Boating Community since 1956.**



# ***BOATLOADS OF CAPACITY***



*Visit Our Website:*  
[www.nelsonsmarine.com](http://www.nelsonsmarine.com)

# ***BOATLOADS OF BOATS***



*For Sale:*  
*Boatloads of Boats!*

In the water or on land, Nelson's Marine has the capacity to accommodate your vessel. Our extensive docks in our protected boat basin and our huge indoor work space provide the space to handle any repair. Our dry-stored brokerage area features a broad selection of great quality yachts ready for inspection.



**SACRAMENTO AFFILIATE: McClellan Indoor Boat & RV Storage**  
**(916) 640-0141 • [www.mcclellanstorage.com](http://www.mcclellanstorage.com)**



**NELSON**  
*Yachts*

**Brokerage • (510) 337-2870**  
*See ad page 25*

**Sacramento  
Yacht Sales  
Opening  
Soon**

*Nelson's Marine*

[www.nelsonsmarine.com](http://www.nelsonsmarine.com)  
1500 FERRY POINT  
ALAMEDA, CA 94501  
**(510) 814-1858 • FAX (510) 769-0815**