

Latitude 38

Latitude 38

VOLUME 364 October 2007

WE GO WHERE THE WIND BLOWS



OCTOBER 2007

VOLUME 364

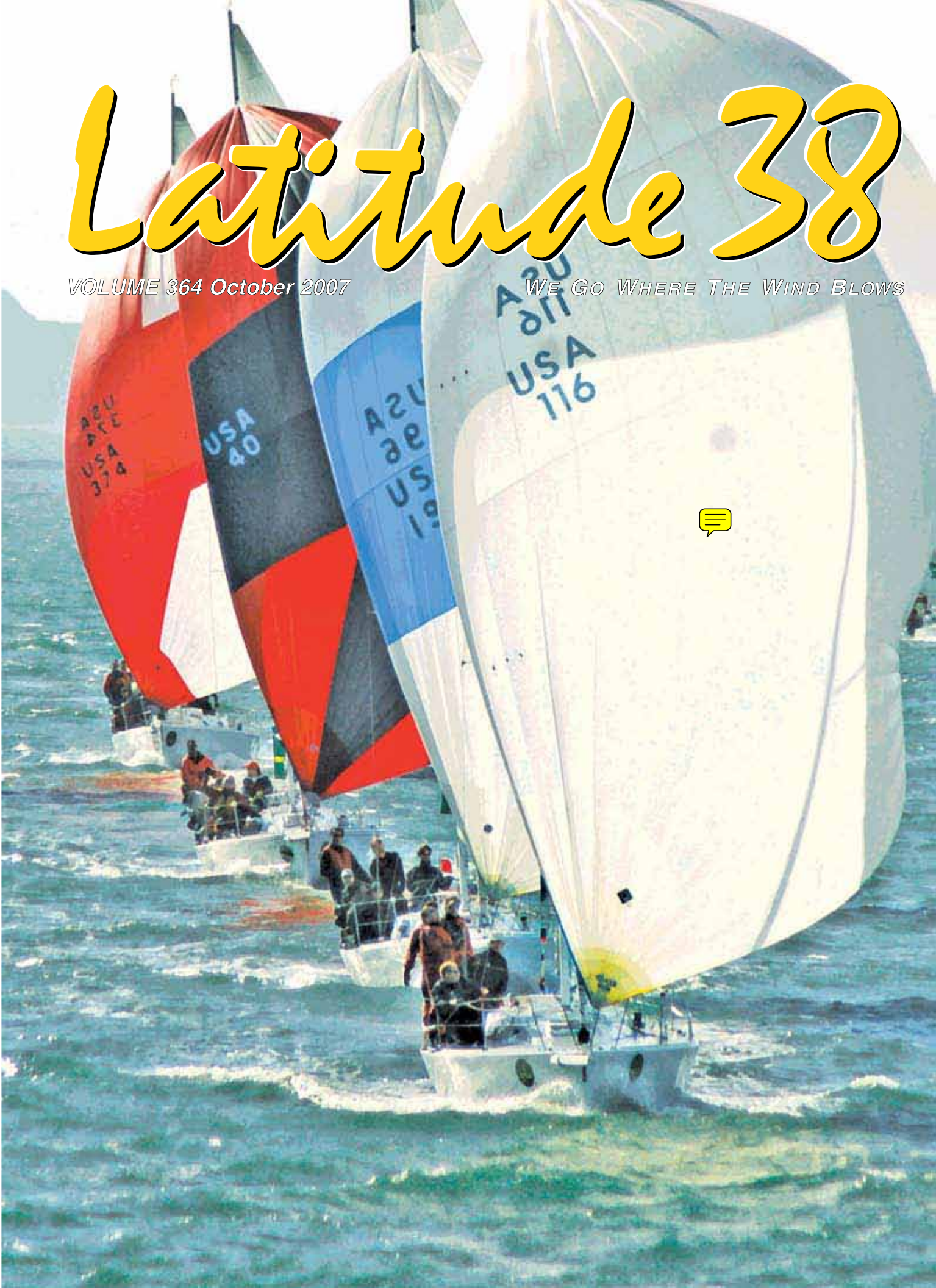

Grand Marina



**Grand Marina is a safe haven for yachtsmen.
Leave your boat in our landlocked full service marina with
a complete boatyard facility and walk away knowing your
boat is safe and sound.**

- Over 400 concrete berths 30 to 60 feet
- Secured Gatehouses (electronic key system)
- Dockside Electrical (up to 50A - 220V)
- Cable TV & Telephone Service
- Heated & tiled restrooms with individual showers
- Beautifully Landscaped
- Ample Parking available
- Sailboat & Powerboat Brokers on site
- Excellent customer service
- Monthly informative newsletter

DIRECTORY of GRAND MARINA TENANTS

Bay Island Yachts	7
Bay Marine Diesel	191
The Boat Yard at Grand Marina	22
Lee Sails.....	216
New Era Yachts	232
Pacific Coast Canvas	87
Pacific Yacht Imports	9



GRAND MARINA
ANDERSON-ENCINAL

510-865-1200

Leasing Office Open Daily
2099 Grand Street, Alameda, CA 94501
www.grandmarina.com

Our wait list for liveaboard status is now closed.

Winning with *Elan*

Starting with first place finishes in this year's season opener to Vallejo and back, Bill Riess's Express 37, *Elan*, sailed a stellar 2007 series, finishing first in the Express 37 One Design class with nine points to spare.

Bill began buying Pineapple Sails for his Coronado 25 in the late 1970's, then his Olson 25 in 1988 and *Elan* since 1999.

Much of Bill's crew has been sailing with him for 10 years and most more than 4. They find him fun to work with and work for. We couldn't agree more.

Sailmaking materials have changed. Sailmaking techniques have changed. The importance of a sailmaker who gives you the best materials, the best workmanship and the best service has not. Let us work with and for you.



PHOTO: MARIAHS EYES PHOTOGRAPHY (510) 864-1144

*Elan**

YOUR DEALER FOR: Musto foul weather gear, Dubarry footwear and Headfoil 2

Sails in need of repair may be dropped off at:
West Marine in Oakland, Alameda, or Richmond;
or Svendsen's in Alameda.

*Powered by Pineapples



PINEAPPLE SAILS

Phone (510) 522-2200

Fax (510) 522-7700

www.pineapplesails.com

2526 Blanding Ave., Alameda, California 94501

Innovative design and building technology

New 2008 Models



BENETEAU 43



In life there are leaders, and there are followers. Beneteau, Island Packet, and Wauquiez continue to set the standard for design innovation and deliver you more comfort, greater sophistication in styling, the latest in sailing equipment innovations, and true, long-term value.

For premium builders like Beneteau, Wauquiez, and Island Packet, you can be assured that your new boat will give you years of reliable use, pride of ownership and one of the highest resale values in the industry.

**Real Value in
a World of
Promises**



BENETEAU 40



BENETEAU 49



ISLAND PACKET 465

**October
Events
Calendar**

October 12, 13 & 14

Beneteau Annual Rendezvous and Intensely Fun Regatta
(Owners, please call if you have not received your registration!)

October 27

Pt. Richmond Open House Boats ~ Food ~ Fun ~ Sails

and the pursuit of the exceptional...

In today's world you can't afford to waste time and money on mediocre experiences and products. Our 25 years of industry experience have taught us that real value is not an interesting story or slick brochure. Our products offer the best in engineering, overall performance and luxury. That is why our customers keep coming back for their next boat.

If you are in the market, stop by to see our talented and knowledgeable staff. With a combined sailing experience of 173 years, from world class racing to serious world cruising, you're guaranteed to get the right advice and have an experience of a lifetime.

Boutique Models



BENETEAU 57



WAUQUIEZ 55



ISLAND PACKET SP 41



WAUQUIEZ 41 PS

**Beneteau • Island Packet
Wauquiez • Alerion**

Featured Brokerage Boat



**BENETEAU 473, 2002
\$229,000**

**See our complete
list on page 229.**

**SERIOUS ABOUT
SELLING?**

With two Bay Area
locations, we are
serious about selling
your boat.

Call us when you're
ready to sell!



Pt. Richmond Office
1220 Brickyard Cove Road
p: 510-236-2633 f: 510-234-0118

Alameda Office • Marina Village
1070 Marina Village Pkwy, Ste 101
p: 510-864-3000 f: 510-337-0565

www.passageyachts.com
sales@passageyachts.com

PUSSER'S
*"The single malt of rum
 and the father of grog"*



Forbes writes, "Pusser's is still made in the same way it was at the time of Trafalgar - in wooden pot-stills as opposed to modern industrial column-stills. This results in the most full flavored rum available anywhere".



The original Navy Rum and the father of grog as the rum of Great Britain's Royal Navy and Royal Marines for more than two centuries.



Gold Medals, London, 2001
 San Francisco, 2003 & 2005



Pusser's isn't for everyone. Some people prefer rums that are almost flavorless when compared to the intensely rich flavor of Pusser's. But if you want a rum that you can enjoy sipping, or still taste through the mix of your favorite cocktail, then Pusser's is for you. Try a Pusser's and Cola sometime and taste the difference.

Pusser's is not always easy to find but your local retailer can order it for you. Or take a look at HOW TO FIND IT on our web site at

www.pusser.com

Charles Tobias
 Charles Tobias, Chairman

CONTENTS

subscriptions	8
calendar	32
letters	42
loose lips	102
sightings	106
rolex big boat series	124
glacier bay	138
spearfishing	142
eye on the bay	146
ssb tips	148
ha-ha profiles, pt. II	156
max ebb: duck and cover	166
the racing sheet	170
world of chartering	184
changes in latitudes	192
classy classifieds	212
advertisers' index	223
brokerage	226

Cover: J/105s charge down the homestretch at the Rolex Big Boat Series.

Photo by: Latitude 38/JR

Copyright 2007 Latitude 38 Publishing Co., Inc.

Latitude 38 welcomes editorial contributions in the form of stories, anecdotes, photographs - anything but poems, please; we gotta draw the line somewhere. Articles with the best chance at publication must 1) pertain to a West Coast or universal sailing audience, 2) be accompanied by a variety of pertinent, in-focus digital images (preferable) or color or black and white prints with identification of all boats, situations and people therein; and 3) be legible. These days, we prefer to receive both text and photos electronically, but if you send by mail, anything you want back must be accompanied by a self-addressed, stamped envelope. **Submissions not accompanied by an SASE will not be returned.** We also advise that you not send original photographs or negatives unless we specifically request them; copies will work just fine. Notification time varies with our workload, but generally runs four to six weeks. Please don't contact us before then by phone or mail. Send all electronic submissions to editorial@latitude38.com, and all snail mail submissions to Latitude 38 editorial department, 15 Locust Ave., Mill Valley, CA 94941. For more specific information, request writers' guidelines from the above address or see www.latitude38.com/writers.htm.



Bay Island YACHTS

(510) 814-0400

yachtsales@bayislandyachts.com

www.bayislandyachts.com

PACIFIC SEACRAFT 34



NEW LISTING

1982. Ready to go cruising!!
\$105,000

HUNTER LEGEND 40



NEW LISTING

1989. Sail! Live aboard! Enjoy!
\$69,500

ISLANDER BAHAMA 30



NEW LISTING

Fresh from Lake Tahoe.
\$22,500

WAUQUIEZ HOOD 38



1979. Truly a performance cruiser.
\$85,500

47' BENETEAU 47.7



REDUCED

Bank is letting her go!
Try \$200,000

32' GAFF-RIG KETCH



CUSTOM

Pacific cruise veteran.
\$55,500

CONTESSA 32



\$39,500

"Old world" quality. Excellent sailing.
\$39,500

36' CATALINA, 1983



NEW LISTING

Two C-36s, 1983 & 1985
\$45,000 & \$57,500

SANTANA 30, 1979



Very complete sailing gear. Clean condition.
\$17,500

35' SCHOCK, 1994



Ex-class champion. "Full race."
\$49,500

42' VENEZIA, 1995



Price reduced to \$195,000 and she is well worth it. Good condition and ready to cruise around the Caribbean. Lying in Grenada, which is a wonderful place to start your dream sail. Call for complete details and for many more cat listings we have available. Our pending cat sales include a 471 Catana, 42 Venezia, 41 Lagoon. We've been selling catamarans since 1993 so if you are considering purchasing one, give us a call!

YOUR MULTIHULL BROKERAGE SPECIALIST

SAILING CATS

82' CNB.....	\$1,700,000
56' MARQUISES, 1997.....	€390,000
50' TROPIC, 1993.....	€253,000
48' PRIVILEGE, 1991.....	\$400,000
48' PRIVILEGE, 1990.....	\$400,000
44' KOHLER, 1993.....	\$249,000
43' BELIZE, 2003.....	\$416,000

43' LAGOON POWER CAT, 2003 \$550,000

42' VENEZIA, 1995.....	\$195,000
38' ATHENA, 1998.....	\$185,000
33' SEAWIND, 2000.....	\$182,000

POWER CATS

40' EUPHORIE, 1991.....	€145,000
37' MARYLAND, 2002.....	315,000

MONOHULLS FOR SALE IN THE CARIBBEAN

52' NAUTICAT.....	\$390,000
?? BENETEAU.....	\$189,000
50' JEANNEAU.....	\$290,000
47' WAUQUIEZ.....	\$219,000
47' JEANNEAU.....	\$155,000

47' BENETEAU.....	\$275,000
47' SWAN.....	\$199,000
43' SAGA.....	\$272,000
43' SLOCUM.....	\$160,000

SOLD

ALEUTIAN 51 BENETEAU 39
ERICSON 35 (2)
MORGAN 41 HUNTER 29.5
ISLANDER 32 CATALINA 34
CATALINA 36 BENETEAU 40S
HUNTER 430 SPINDRIFT 43
ERICSON 30+
IRWIN 46 ISLANDER 37
COMPAC 25
NONSUCH 30 (2)
HUNTER 29.5 ERICSON 28
O'DAY 30 HUNTER 45 (2)
CATALINA 27 PEARSON 32
BENETEAU 42s7
FORMOSA 51 HUNTER 33
BENETEAU 390 CHB 34
HUNTER 37.5 NEWPORT 33
HUNTER 40 ISLANDER 30
HUNTER 37 NEWPORT 30

NONSUCH 36, 1987



'FAST LUCY'

Lovable, simple, elegant!
\$102,500

NONSUCH 33, 1989



NEW PRICE!

Pretty in Green!
\$112,500

NONSUCH 30, 1982



CLASSIC

She's a Nonsuch. Simple. \$49,500

NEW LISTINGS, PENDING:

NAUTICAT 33
AMEL 48
HUNTER 31
NORTHSTAR 40

YACHTWORLD.com

In Grand Marina • 2099 Grand St., Alameda, CA 94501 • Fax (510) 814-8765

BOAT LOANS

from



Trident Funding

*"a fresh approach from
people you can trust"*

*In Northern California call
JOAN BURLEIGH*

(800) 690-7770

*In Southern California call
JEFF LONG*

MARGE BROOKSHIRE

(888) 883-8634

In San Diego

MIKE LOCKARD

(619) 255-5666

www.tridentfunding.com

SUBSCRIPTIONS

Please read form carefully before submitting.

We regret that we cannot accept foreign subscriptions. Check, money order, or credit card information must accompany request. Please allow 4-6 wks to process changes/additions, plus delivery time.

Enclosed is \$18 for one year on eBook

Check out www.latitude38.com and click on eBooks to see what we're talking about. Our eBooks are now in PDF format, easy to use with Adobe Reader



Enclosed is \$36 for one year Third Class Postage

(Delivery time 2-3 weeks; Postal Service will not forward third class, so you must make address change with us in writing.)

Enclosed is \$55 for one year First Class Postage (Delivery time 2-3 days; FPO/APO (military), Canada & Mexico subscriptions are first class only)

Third Class Renewal First Class Renewal *(current subs. only!)*

Gift Subscription – Card to read from: _____

Name _____

Address _____

City _____

State _____

Zip _____

Phone: () _____ Email: _____

CREDIT CARD INFORMATION
Min. Charge \$20

MASTERCARD

VISA

AMERICAN EXPRESS

Number: _____ Exp. Date: _____

INDIVIDUAL ISSUE ORDERS

Current issue = \$6.00 • With classy ad placed = \$5.00

Back Issues = \$7.00 (must indicate exact issue by month or vol. #)

DISTRIBUTION

We have a marine-oriented business/yacht club in California which will distribute copies of *Latitude 38*. (Please fill out your name and address and mail it to the address below. Distribution will be supplied upon approval.)

Please send me further information for distribution outside California

Business Name _____

Type of Business _____

Address _____

City _____

State _____

Zip _____

County _____

Phone Number _____

Latitude 38

"we go where the wind blows"

Publisher/Exec. Editor.....Richard Spindler.....richard@latitude38.com.....ext. 111
Associate Publisher.....John Arndt.....john@latitude38.com.....ext. 108
Managing Editor.....John Riise.....johnr@latitude38.com.....ext. 110
Senior Editor.....Andy Turpin.....andy@latitude38.com.....ext. 112
Staff Writer.....LaDonna Bubak.....ladonna@latitude38.com.....ext. 109
Staff Writer.....Lindsay Cohen.....lindsay@latitude38.com.....ext. 105
Advertising Sales.....John Arndt.....john@latitude38.com.....ext. 108
Advertising Sales.....Shawn Grassman.....shawn@latitude38.com.....ext. 107
Classified Sales.....Mary Briggs.....class@latitude38.com.....ext. 104
General Manager.....Colleen Levine.....colleen@latitude38.com.....ext. 102
Production/Web.....Christine Weaver.....chris@latitude38.com.....ext. 103
Production/Photos.....Annie Bates-Winship.....annie@latitude38.com.....ext. 106
Bookkeeping.....Helen Nichols.....helen@latitude38.com.....ext. 101

Directions to our office.....press 4
Subscriptions.....press 1,4
Classified.....class@latitude38.com.....press 1,1
Distribution.....distribution@latitude38.com.....press 1,5
Editorial.....editorial@latitude38.com.....press 1,6
Calendar.....calendar@latitude38.com
Other email.....general@latitude38.com.....Website: www.latitude38.com

15 Locust Avenue, Mill Valley, CA 94941 • (415) 383-8200 Fax: (415) 383-5816

Please address all correspondence by person or department name



Tayana 54 Deck Saloon

NEW TAYANA 54 DECK SALOON

Performance cruiser by Bill Dixon. Custom built to your specifications by Tayana. Two, three and four stateroom options available.



Tayana 58 DS

TAYANA 58 DECK SALOON

World famous Tayana 58 Deck Saloon. Fast and stable, custom interior. More than 100 hulls built!



Tayana 64 Deck Saloon

TAYANA 64 DECK SALOON

Robb Ladd design. Center or twin cockpit. 18-ft beam and long waterline. Modern looking bluewater cruiser.

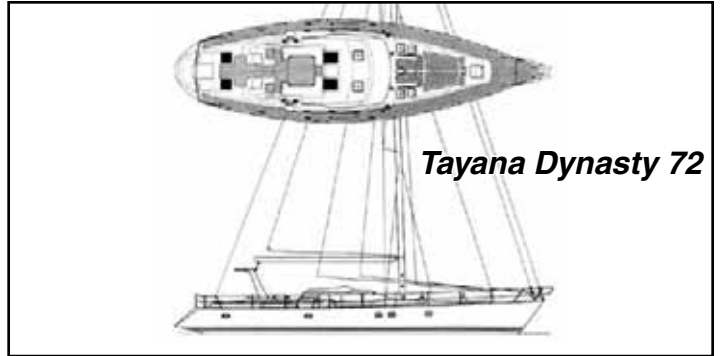

Tayana Dynasty 72

TAYANA DYNASTY 72

Designed by Bill Dixon/Andrew Winch. Cruise in luxury on this 72-footer with 20-ft beam. Many interior plans to choose from. Fast and spacious.



NEW LISTING

2005 TAYANA 48 CC

Like new and loaded. 500 hours on Yanmar 75 turbo. LeisureFurl, electric winches, KVH 33 Imarsat phone. **\$489,000**



SOLD

2002 TAYANA 48 DECK SALOON

Well-equipped, hard-to-find, rare Deck Saloon 48. Just back from Mexico. Watermaker, LeisureFurl, electric winches. Pristine! **SOLD**



AT OUR DOCKS

NEW TAYANA 46 PILOTHOUSE

Three-stateroom model with inside steering and all the quality craftsmanship you have come to expect from Tayana Yachts. **\$385,000**



1988 HANS CHRISTIAN 41 Molokai

In as fine a condition as one will hope to find in a yacht of this caliber. Fully equipped. **\$250,000**



SISTERSHIP

2000 BENETEAU FIRST 40.7. Race ready with many upgrades like larger motor, oversize primary winches, carbon spin pole, professionally faired. **\$189,000**



REDUCED

1987 MORGAN 41 CLASSIC. Modernized version of Charlie Morgan's very popular Out-Island 41. Updated inter. design; improved underbody w/fin keel. **\$105,000**



PRICE SLASHED

1979 EXPLORER 45 KETCH. Designed by Stan Huntingford. Exceptional cruiser of moderately heavy displacement yet timeless flowing lines. Well equipped, warm interior layout. Reduced to **\$75,000**



READY TO SHIP

2007 TAYANA 48 DECK SALOON Our most popular 2-stateroom 2-head model. You can still add any factory options. Many extras at a discounted price. Ready to ship. **\$430,000**

Pacific Yacht Imports

2051 Grand Street, Alameda, CA 94501

Tel (510) 865-2541 Fax (510) 865-2369

www.yachtworld.com/pacificyachtimports • tayana@mindspring.com

We're at Grand Marina

Keith Rarick, Neil Weinberg, Dave Wolfe

NO PAYMENTS FOR 1 YEAR ON '07 HUNTERS America's #1 Seller*



Hunter 38



Hunter 49 Saloon



Hunter 45CC Master Stateroom

New 2008 Models Arriving Weekly • Come Check Them Out!



San Diego • Newport Beach
Marina del Rey • Channel Islands
888-325-4353 • www.hsyacht.com



Cruising Yachts, Inc.

San Francisco Bay
888-789-2248

Monterey Bay
831-333-1597

www.cruisingyachts.net

* OAC - Tier 1 credit. Available on '07 models in stock only. Best Seller source: Statistical Surveys, Inc. ©2007 Cruising Yachts, Inc.



50TH ANNIVERSARY EQUIPMENT PACKAGES FREE ON ALL NEW JEANNEAUS DURING OCTOBER!



Jeanneau 36i — New model for 2007. Sleek, sexy, 2 staterooms, private head with separate stall shower.



Jeanneau 45. Master staterooms fore & aft w/ ensuite heads. Rigged for easy single handling. Beautiful teak interior.



New Jeanneau 39i has been a huge success & in short supply. Now in stock for immediate delivery. Hurry! Last one for this year.



Jeanneau's best seller — 42DS. Huge master stateroom aft w/ centerline queen berth. Fast, elegant, unique styling. In stock now!



San Diego • Newport Beach
Marina del Rey • Channel Islands
888-325-4353 • www.hsyacht.com



San Francisco Bay 888-789-2248
Monterey Bay 831-333-1597
www.cruisingyachts.net

* OAC. Tier 1 credit. © 2007 CYI.

Randall Burg YACHT AND SHIP, INC.

Marina del Rey (310) 574-9449
 Newport Beach (949) 675-5940
 San Diego (619) 222-1907
 Channel Islands (805) 469-9765
 Alameda Coming soon!
 info@rbyachts.com • www.rbyachts.com



Brokerage Slips Available in Long Beach, Marina del Rey & Newport Beach. Stated Income Loans to \$350,000 starting at 6.5%.

55' CUSTOM HERRESHOFF SCHOONER, 1982

Fiberglass, not wood, modeled after a 1935 L. Francis Herreshoff design for a Mobjack ketch. Total refit in 1999 and converted from ketch to schooner rig under the direction of Bob Perry. Exterior repainted in 2000. Bow thruster added 2002. Fully battened main + 8 more sails, 4kw gen, radar/GPS/AP, lcom SSB. Extensively cruised and in excellent condition. \$299,000



51' MASON OFFSHORE YAWL, 1958
 New wiring, plumbing & paint in/out, hydraulic windlass, Volvo 71 hp dsl. \$129,990



46' HUNTER 466 SLOOP, 2004
 Almost new!
 \$235,000



46' HUNTER 460 SLOOP, 2000
 \$217,500



41' HUNTER, 1994
 Loaded and like new.
 \$225,000



459 MERIDIAN, 2005
 \$449,000



33' HUNTER SLOOP, 2004
 Large and spacious.
 \$105,000



38' HUNTER SLOOP, 2001
 Fully equipped.
 \$137,000



47' KETTENBURG SLOOP, 1958
 Fully restored. \$119,000



50' COLUMBIA, 1974
 Custom interior.
 \$199,000



41' MORGAN, 1987
 Dodger, radar, autopilot, davits, Yanmar diesel, etc. \$69,000



36' HUNTER SLOOP, 2003
 Ready to sail.
 \$128,500



38' HANS CHRISTIAN MkII CUTTER, 1983
 Very well equipped.
 \$135,000



36' HUNTER, 2003
 \$128,500



80' SAN LORENZO, 1993
 \$1,895,000



40' BLUEWATER TRAWLER, 1979
 Pristine long range pilothouse.
 \$175,000



47' MCKINNA, 1997
 Aft cabin.
 \$347,500



52' DEFEVER
 Located in La Paz.
 \$135,000



36' DOREL, 2001
 Twin 454s w/125 hrs.
 \$135,500



34' CHB TRAWLER, 1978
 \$60,000



42' GRAND BANKS CLASSIC, 1973
 Well maintained. \$89,000



50' SEA RANGER, 1986
 \$239,000



27' GRADY WHITE WA 274, 2000
 Sailfish. \$87,000

GREAT BROKERAGE VALUES - GREAT SERVICE - CALL FOR VIEWING OR TO LIST YOUR BOAT!

Opening New San Diego Office*

Farallone Yacht Sales

Catalina Yachts

Exclusive San Diego and San Francisco Bay Area Catalina Dealer

now in two locations!

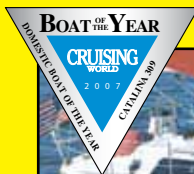

CATALINA 309



CATALINA 320 Mk II



CATALINA 34 Mk II



CATALINA 350 MkII



CATALINA 400



CATALINA 387



CATALINA 42 Mk II - 3 stateroom



CATALINA 440



CATALINA 470

OPEN BOAT WEEKEND • OCTOBER 13-14



Mikelson 50, 1988



Franz Mass 42, 1972



Catalina 380, 2000



3 to choose from

Catalina 36, 2001



Hunter 36, 2004



Valiant 37, 1978

NEW CATALINA YACHTS

In Stock

- Catalina 42 MkII
- Catalina 350 Mkl
- Catalina 309

PREOWNED CATALINA YACHTS

Catalina 380	2000	167,000
Catalina 36	2001	127,000
Catalina 36	1999	89,900
Catalina 36	1989	59,500
Catalina 36	1987	55,000
Catalina 34	1987	47,000
Catalina 30	1990	39,900
Catalina 270	2004	49,500

PREOWNED SAILING YACHTS

Mikelson 50	1988	319,000
Mass 42 ketch	1972	149,950
Hunter 40	1986	59,950
Jeanneau 37	2000	122,000
Valiant 37	1978	79,500
Isl. Freeport 37	1978	63,000
Islander 36	1975	39,000
Hunter 36	2004	112,000

PREOWNED YACHTS (cont.)

C&C 36	1981	47,000
Nonsuch 30	1981	55,000
Hunter 29.5	1996	40,000

Seriously need listings. HIGHLY visible sales docks.

1070 Marina Village Pkwy., # 104
Alameda, CA 94501
T: 510.523.6730
F: 510.523.3041

yacht sales
F A R A L L O N E
www.faralloneyachts.com

*2302 Shelter Island Drive
San Diego, CA 92106
T: 619.523.6730
F: 619.523.3041



5 Convenient Southern California Locations
Open 7 Days a Week • We take trades

CALL TOLL-FREE

888.325.4353

www.HSyacht.com

YOUR SOUTHERN CALIFORNIA DEALER FOR:



HUNTER®
MARINE CORPORATION



JEANNEAU

TRADE-IN CLEARANCE SALE!



1993 Columbia 50 - A/P Radar, Diesel - \$150K



2000 Catalina 36 - Very popular model! \$95K



1979 Mason 43 - Sleeps 6. A classic! \$129,500



2005 Hunter 33 - Very popular model! \$112,500



2004 Beneteau 473 - Custom! Make offer. \$279K



1975 Swan 44 - Sleek & FAST! \$155,000



1990 C&C 37+ - FAST cruiser. \$129,500



1997 Catalina 42 - 3 cabin version \$139K



1998 Catalina 36 - Sleeps 7. \$89,000



1977 Downeaster 38 - RESTORED! \$60,000

2004 MacGregor 26M	\$26,000	1987 Hunter 35.5	\$65,000	2005 Beneteau 393	\$179,000	1990 St. Francis 43	\$199,500
2006 Catalina 28 MK II	\$64,900	2004 Hunter 36	\$138,000	2005 Beneteau 393	\$175,000	2003 Jeanneau 43DS	\$259,500
1990 Hunter 30	\$25,900	2000 Catalina 36 MKII	\$95,000	1997 Catalina 400	\$159,000	1980 Kelly Peterson	\$120,000
2001 Hunter 320	\$69,500	2004 Hunter 36	\$148,000	1996 Hunter 40.5	\$128,500	1975 Nautor Swan 44	\$155,000
2005 Catalina 320	\$139,000	2002 Catalina MK II	\$134,950	1996 Beneteau 400	\$127,500	1998 Hunter 450 Sloop	\$199,500
1990 Hunter 32	\$44,000	1986 Catalina 36	\$57,500	2004 Hunter 41 AC	\$229,900	1999 Hunter 45	\$199,000
1997 Catalina 320 Sloop	\$59,500	1978 Islander 36	\$55,000	1999 Hunter 410	\$169,000	2000 Hunter 450	\$209,000
1989 Ericson 32	\$48,000	2001 Catalina 36 MKII	\$125,900	2000 Hunter 410	\$165,000	2004 Hunter 466	\$279,000
2005 Hunter 33	\$119,500	1998 Catalina 36	\$89,000	1984 C&C 41	\$89,000	2000 Jeanneau 45.2	\$259,000
2004 Hunter 33	\$114,900	2007 Hunter 36	\$166,000	2001 Hunter 420	\$199,000	2000 Hunter 46	\$159,000
2005 Hunter 33	\$107,900	1996 Beneteau 36s7	\$97,000	1997 Catalina 42 MK II	\$139,000	2000 Hunter 460	\$219,500
2007 Hunter 33	\$124,500	2002 Tartan 3700	\$229,000	1994 Hunter Passage 42	\$139,000	2001 Catalina 470	\$269,000
2006 Catalina 34 MK II	\$149,900	1994 Hunter 37.5	\$87,000	1993 Catalina 42	\$134,900	2007 Jeanneau 49 DS	\$480,000
1989 Hunter 33.5	\$42,500	1980 Tayana 37	\$115,000	1991 Hunter Passage 42	\$139,000	1993 Columbia 50	\$150,000
2001 Hunter 340	\$89,900	2005 Hunter 38	\$199,500	1989 Irwin 43 Mark III	\$145,000	2000 Jeanneau 52.2	\$429,900
1988 Schock 35	\$55,000	2006 Hunter 38	\$192,246	2001 Dufour Gib Sea 43	\$160,000	1982 Cooper Ent 51	\$179,000
1985 Schock 35	\$25,000	1999 Hunter 380	\$120,000	1979 Ta Shing Mason 43	\$128,500	1981 Pearson 530	\$289,000
1992 Hunter Legend 35.5	\$59,900	1977 Downeaster 38	\$60,000	1998 Hunter 430	\$156,000		

SELL YOUR BOAT *FASTER* WITH H&S

- WE SELL MORE 30'- 60' SAILBOATS THAN ANYONE!
- You'll have over 25 salesmen marketing your boat from 5 offices across Southern California.
- Your boat will appear on the leading boating websites, printed boating publications and at boat shows.



SAN DIEGO | NEWPORT BEACH | MARINA DEL REY | CHANNEL ISLANDS

Golden Gate Yacht Sales



Proud Dealers for



2007 Salona 37 Racer/Cruiser



2008 Sabre 42 Hardtop Sedan

We have Buyers! We need listings! Sell your boat with one of California's most active Brokerages



**1996 Beale 47
\$259,000**



**1999 Outbound 44
\$339,000**



**1998 Morgan Center Cockpit
\$149,000**



**1997 Tashiba 40
\$250,000**



**1964 Cal 40
\$69,500**



**2000 Sydney 38 OD
\$195,000**



**1990 Sabre 38 Mk II
\$129,900**



**1985 Beneteau 38
\$80,000**



**1997 30' J/92
\$54,900**

(415) 332-2120 • 301 Harbor Drive, Sausalito, CA 94965 • www.goldengateyachts.com

TARTAN
YACHTS



**TARTAN
4100**
View at our
Sales Dock

Call for
APPT.

C&C
YACHTS

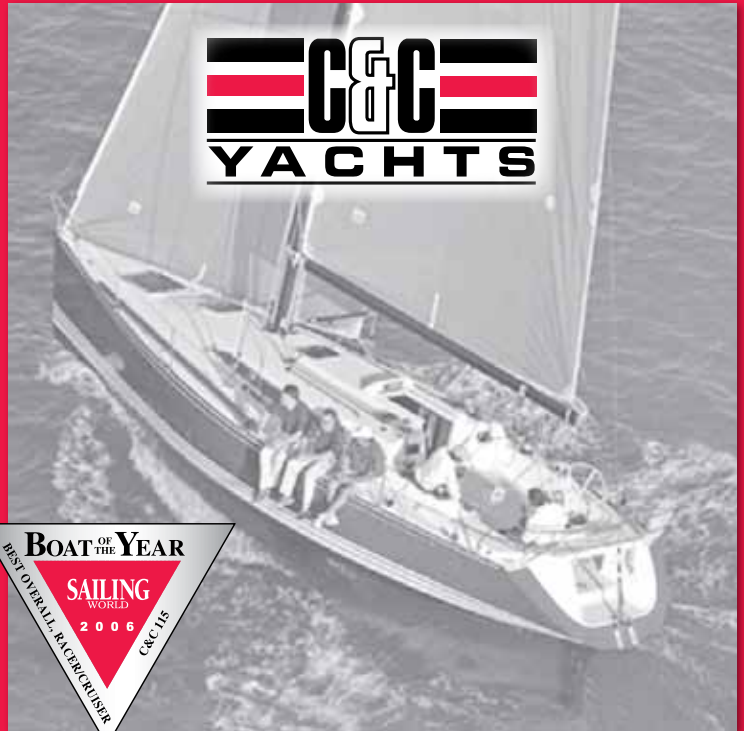

TARTAN NEW 5300 • NEW 5100 • 4400
NEW 4300 • 4100 • 3700 • NEW 3400

C&C 121 • C&C 115 • C&C 110
C&C 99 • ONE DESIGN SPECS

NOW STANDARD ON ALL TARTANS AND C&Cs
Carbon Spar, Epoxy Hull, 15-Year Hull Warranty



GULFSTAR 50, 1978
Mexico ready. \$125,000



BENETEAU FIRST 305, 1986
Diesel, race equipped. \$36,000



CAPE DORY 33
Clean, quality. SOLD



PASSPORT 40, 1982
Diesel, dodger, nice. \$128,000



30' S-2 CC, 1977
Diesel. \$32,000

OPEN BOAT WEEKEND
OCTOBER 13-14

*Our brokerage boats are selling.
Call us to list yours here now!*



Klaus Kutz
Broker

Don Wilson
Broker



TAYANA VANCOUVER 42, 1979
Cruise ready. Call for appt. \$99,500



WHITBY 42, 1981. Cruising classic,
clean, roller furling. \$79,500

**YOUR
LISTING
HERE!**



VALIANT 40, 1981. Great value
on a Bob Perry classic. SOLD



TARTAN 3400, 2006
SOLD

ISLANDER 40 SOLD SPARKMAN & STEPHENS 47 SOLD
PACIFIC SEACRAFT 44 SOLD CAPE DORY 36 SOLD

Tartan C&C Yachts of San Francisco
1070 Marina Village Parkway, Suite 102, Alameda, CA 94501
(510) 769-9400 • www.tccsf.com



PASSPORT 40, 1986. Cruise ready,
well equipped. \$149,500

Cityyachts

San Francisco's yacht broker
since 1969



SISTERSHIP

YACHTS AND THE CITY



Albin 28 Tournament Express
\$129,950

Harbormaster 37
Ideal City location. \$80,000



PENDING

SISTERSHIP

Bertram 42
\$87,500



Morgan 41 Out Island
2 from \$54,900



Ohlson 41
\$49,950



Newport 41 Mk II
\$39,500



Bayliner 28, 2000
\$57,000



Californian Aft Cabin 36, '83
\$74,900



Islander 36
\$28,900



Islander 30 Mark II
\$16,500



Islander 36
Perfect City location. \$55,000

10 MARINA BL. • SAN FRANCISCO, CA 94123 • Toll Free: 877-444-5091 • 415-567-8880
FAX (415) 567-6725 • email sales@citysf.com • website <http://yachtworld.com/cityyachts>



PLEASE VISIT OUR FUEL DOCK AT GASHOUSE COVE MARINA • OPEN 7 DAYS A WEEK • 9AM TO 5PM

BRISBANE MARINA FESTIVAL

Sunday, October 28, 2007 • 10am-4pm



Boat Rides & Tours
Amazing & Unusual Boats
on Display



Live Music!
Children's Activities &
Radio Controlled Car Races



Classic Car Show
on the
Marina Green



Food & Beverages



Barbeque



Booths & Exhibits



Sierra Point Prowl
Lion's Club 5K/10K Fun Run

FREE ADMISSION
FREE PARKING



Fire & Police Dept. Demos
FROM HWY. 101, TAKE THE
SIERRA POINT PARKWAY EXIT

(650) 583-6975
www.ci.brisbane.ca.us



OUR STAR ATTRACTIONS

POWER

- 93/03 80' San Lorenzo \$1,890,000
- 1988 73' Philbrook \$899,000
- 2004 53' Barge \$65,000
- 1984 49' Kha Shing \$179,500
- 1997 48' McKinna \$497,000
- 1992 48' Navigator \$369,000
- 1997 48' Jarvis Newman \$479,000
- 1996 46' Viking \$374,500
- 2006 44' Sea Ray \$489,000
- 1979 44' Marine Trader \$139,500
- 1987 43' Kha Shing \$210,000
- 1984 43' Bestway \$144,900
- 1988 42' Ocean Alexander \$224,000
- 1984 40' Kha Shing \$139,500
- 2002 39' Mainship \$184,000
- 1987 38' Riviera \$159,500
- 1965 38' Chris Craft \$47,500
- 2005 36' Meridian \$279,000
- 1972 34' CHB \$42,500
- 1980 34' Mainship \$49,500
- 1984 32' Island Gypsy \$71,000
- 1989 32' Bayliner \$69,900
- 1997 31' Albin \$139,500
- 1990 31' Tiara \$64,900
- 1982 31' Sea Horse \$44,500
- 2000 30' Pursuit \$94,900
- 2000 28' Albin \$124,950
- 1987 28' Fairline \$32,500
- 2000 27' Sea Sport \$99,500
- 1997 26' Skipjack \$59,700



57' 2006 BENETEAU



50' 1987 SANTA CRUZ



37' 1985 AMAZON



43' 1987 SPINDRIFT



40' 1990 HUNTER



40' 1995 CATALINA

SAIL

- 2006 57' Beneteau \$795,000
- 1977 50' Gulfstar \$115,000
- 1987 50' Santa Cruz \$215,000
- 1989 48' Hans Christian \$369,500
- 1987 43' Spindrift \$179,900
- 1999 43' Shannon \$499,000
- 1990 40' Hunter \$74,500
- 1995 40' Catalina \$125,000
- 2000 40' Pacific Seacraft \$299,500
- 1982 38' Morgan \$70,000
- 1985 37' Amazon \$157,500
- 1999 37' Pacific Seacraft \$229,500
- 1987 36' Catalina \$52,000
- 1984 35' C&C \$42,500
- 1981 35' Hinterhoeller \$69,500
- 1980 28' Shannon \$59,900



43' 1999 SHANNON



BOATS - BOATS - BOATS

FOOD - MUSIC - FUN
INFORMATION - CAMARADERIE

Contact Us For Your
Invitation To This
Sausalito Celebration

Yachts
McGrath

open 7 days a week



TAKE MORE THAN JUST A PEEK AT OUR
48' HANS CHRISTIAN
A DREAM COME TRUE

McGrath Yachts, Inc 41 Liberty Ship Way Sausalito CA 94965 415.331.5020 www.McGrathYachts.com



ALAMEDA MARINA

1815 Clement Ave., Alameda ~ (510) 521-1133
www.alamedamarina.net



A MARINA TO SUIT ALL YOUR NEEDS

- 530 Wet Berths 22-40 ft
- End Ties 40-70 ft
- Dry Storage – Trailer Boats
- RV & Camper Storage
- **Easy Access by Car or Boat**



Our tenants include some of the most respected names in the sailing industry, representing a full spectrum of services. Visit us today.

<p>Doyle Sailmakers 2035 Clement, Bldg. 32C (510) 523-9411 <i>Better Engineered Sails</i></p>	<p>L.T.D. Marine Electrical 2035-B Clement, Bldg. 32B (510) 523-2521 www.ltdmarine.com</p>
<p>Eskelund Marine Volvo Service 1913 Clement, Bldg. 13 at Pier 2 (510) 523-7670 <i>Volvo Penta specialist since 1980</i></p>	<p>Reliable Marine Electronics 1925 Lafayette (510) 864-7141 www.reliablemarine.com</p>
<p>Hogin Sails 1801-D Clement, Bldg. 28A (510) 523-4388 www.hoginsails.com</p>	<p>Sal's Inflatable Services, Inc. 1914 Stanford (510) 522-1824 <i>Your Survival is Our Business</i></p>
<p>The Japan Woodworker 1731 Clement (510) 521-1810 www.japanwoodworker.com</p>	<p>Svendsen's Boat Works/Chandlery/Metal Works 1851 Clement (510) 522-2886 www.svendsens.com</p>
<p>HF Radio On Board 1813 Clement, Bldg. 24 (510) 814-8888 www.hfradio.com</p>	<p>Waypoint 1813 Clement, Bldg. 24 (510) 769-1547 www.waypoints.com</p>



Hans Christian



Flying Cloud Yachts

Sail • BROKERS • Power



6400 Marina Dr., Long Beach, CA 90803

Phone (562) 594-9716 Fax (562) 594-0710



NEW 105Mc - GEMINI, 2008
Best selling cruising catamaran in the U.S.!
\$154,500



57' BOWMAN KETCH, 1978
Five hours on rebuilt 110hp Perkins. New electronics. Top-quality bluewater cruiser. \$249,000



44' PETERSON CUTTER, 1980
Beautiful bluewater cruiser!
\$96,000



45' HUNTER SLOOP, 1999
Very clean and sharp, shows little use. Just reduced, serious seller. \$199,500



42' CATALINA, 1992-1998
New Yanmar diesel. New sails. Two staterooms. Very clean. Also a '99 w/3 strms. From \$123,500



37' C&C, 1984
Pristine condition! Low hours on Yanmar diesel. Loads of upgrades! \$74,500



35' CHARTER CATS WILDCAT, 2001
Space & performance in ready to cruise cat. 4 strms, hard bottom dinghy, good electronics. \$209,000



47' GIL'S CHOY CATAMARAN, 2002
Ready to cruise the South Pacific today! Everything as new, fully equipped. \$400,000



39 NAUTOR SWAN SLOOP, 1984
Pristine construction and sailing performance, set up for offshore cruising. \$129,000

Web site: www.yachtworld.com/fcyachts • email: flyingcloud@verizon.net



43' CONTESSA SLOOP, 1978
Performance designed by Doug Peterson. Quality construction. Must see! \$139,000



43' COLUMBIA SLOOP, 1969
\$50,000



42' PEARSON KETCH, 1978
Aft cockpit, aft stateroom cruising ketch, excellent construction. \$79,950



41' NAUTOR'S SWAN, 1973
Clean and ready to sail. New LP and new bottom paint in 5/07. 120,000



41' YORKTOWN, 1985, \$49,500
39' YORKTOWN, 1976, \$39,500



41' ERICSON SLOOP, 1969
Under 20 hours on Perkins 4-108. Exceptionally nice inside and out. Lots of upgrades. \$46,500



40' CARROL MARINE TRIPP 40, 1991
\$64,900



40' ISLANDER PETERSON, 1982
Well maintained by original owner. \$69,000



38' HANS CHRISTIANS
1980-1986
From \$99,000



36' CATALINA SLOOP, 1984
Very clean. Owners moved out of country - need offers! \$59,000



36' C&C SLOOP, 1981
Clean, good sails and equipment, FAST. \$45,900



30' DIDHAM / PETERSON SLOOP, 1979
Cold-molded performance cruiser in excellent condition. \$23,000



32' CATALINA SLOOP, 2003. Clean, lightly used, 100 hrs on Yanmar diesel. Refrigeration, BBQ & walk thru transom. \$104,000.



32' WESTSAIL CUTTER, 1976. New engine, new standing & running gear, five new sails, new roller furling, new electronics. \$55,000



29' ERICSON SLOOP, 1978
Bristol condition, \$19,500.
Also: 29' ERICSON, 1972, \$10,900



25' FISHER PILOTHOUSE, 1975. Beautifully built, serious long range pocket cruiser/motor sailer. Excellent cond., a rare find! \$34,500

Some boats shown may be sisterships.

THE BOAT YARD AT GRAND MARINA

Formerly Mariner Boat Yard

"Where Service Has Meaning"

**60-TON
TRAVELIFT**

*The only yard to brush
on your bottom paint!*

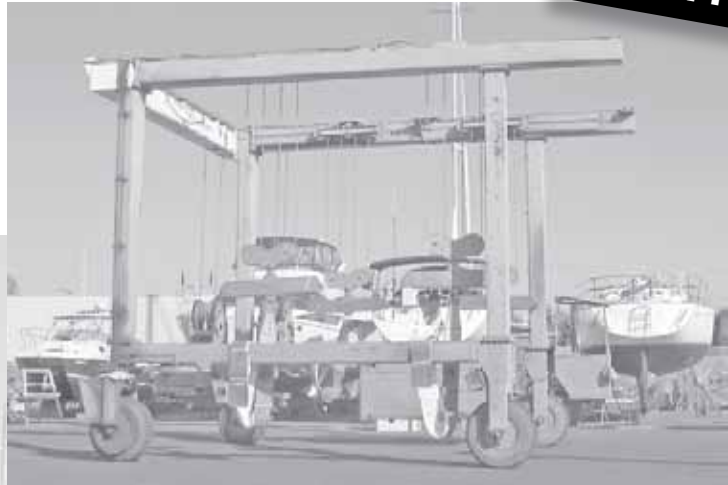

FEATURING
TRINIDAD
ANTI-FOULING PAINT BY
PETTIT
marine paint
RATED "SUPERIOR" by
Practical Sailor

Dealers for:

MAX-PROP
AUTOMATIC FEATHERING PROPELLERS

GORI
marine

Webasto

PACKLESS SEALING SYSTEM
SHAFT SEAL

LECTRA/san

SIDE-POWER
Thruster systems

PROFURL

facnor
FURLING SYSTEMS INC.

AQUAMARINE
FINE REVERSE OSMOSIS EQUIPMENT

IT'S SIMPLE!

Call The Boat Yard at Grand Marina for the Lowest Bottom Prices!

~ COMPARE US WITH THE COMPETITION ~

- Prop and Shaft Work
- Mast & Rigging Repair
- Fiberglass & Blister Repair
- Gelcoat Repair
- Gas & Diesel Engine Service
- LPU Hull & Topside
- Electrical Repair & Installation

CALL FOR A RESERVATION

(510) 521-6100 • Fax (510) 521-3684

Located at Grand Marina • 2021 Alaska Packer Place, Alameda

www.boatyardgm.com

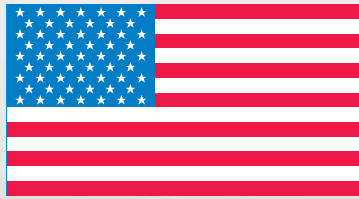

Along with a great place to berth your boat, San Leandro Marina offers you a wealth of recreational opportunities...

- 27 holes of championship golf
- A waterfront hotel
- Fine dining at 2 restaurants overlooking the water
- 40 acres of shoreline park and picnic sites
- 300 acres of tidal wetlands on the Bay Trail
- 2 active yacht clubs



(510) 357-7447

www.ci.san-leandro.ca.us/slmarina.html



BALLENABAY YACHT BROKERS



1150 Ballena Blvd. #121, Alameda, CA 94501 ♦ (510) 865-8600 ♦ Fax (510) 865-5560
2736 Shelter Island Drive, San Diego, CA 92106 ♦ (619) 523-1151

♦ www.ballenabayyachts.com ♦ www.trawlers.com ♦ www.yachtworld.com/ballenabay ♦



California dealer for

Valiant  Yachts

**New 42' Valiant
Coming in November!!**



33' MASON CUTTER, 1987
Bristol condition. Professionally maintained. A must see boat! **\$114,500**



41' COOPER PILOTHOUSE, 1981
Comfortable, bluewater-capable boat. **\$99,500**



39' VALIANT, 1997
One owner, ocean veteran ready for cruising. **\$229,500**

Check our Web sites for other fine listings!

FULL SERVICE BOATYARD

Haulouts for Bottom Painting

Interlux
yachtpaint.com

Small yard offers specialized service.

Servicing California Marine and Industrial Engines

Perkins Authorized Master Service Dealer

SALES SERVICE PARTS



NEW MARINE DIESELS

Perkins DIESELS

10% OFF

GENUINE PERKINS PARTS

Mention this ad ~ Good until 10/31/07

We ship worldwide

BRITISH MARINE



& INDUSTRIAL

#11 Embarcadero Cove
Oakland, CA 94606

**(800) 400-2757
(510) 534-2757**

Conveniently located on the Oakland Estuary, 2 blocks from West Marine

www.britishmarine-usa.com

STARBUCK CANVAS WORKS

Serving the entire Bay Area except Alameda

"Intelligently designed..."



"...and highly evolved"



67 Libertyship Way
Sausalito, CA 94965
415•332•2509

OPEN HOUSE

For Prospective Members
Sunday, October 14, 2007
9am-Noon

We'll be providing complimentary Mimosas, yummy Muffins and a tour of our facilities in exchange for an opportunity to show you why OYC is known as - *The Friendliest Club on the Bay!*

OYC Members: Invite an interested friend!

After the tour, please stay for our lavish brunch buffet, available for \$9.50. You won't find a better buy on the Estuary.

If you think you might attend, we'd ap-

Oakland Yacht Club

Pacific Marina (Foot of Triumph)
Alameda, Ca

The Friendliest Club on the Bay

www.oaklandyachtclub.com

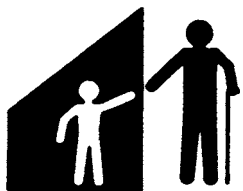

AGAPE VILLAGES



**FOSTER
CHILDREN
NEED YOUR
HELP!**

Donate your boat to support

**AGAPE
VILLAGES**

Tax Deductible

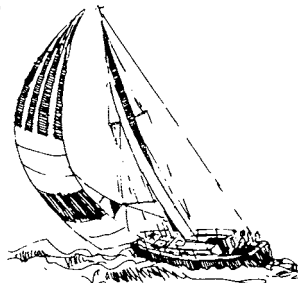

1-800-513-6560

Bow Wow!

Offset hinge enables
lashing to forestay

Pull the pin and it
hinges open for easy
luff tape loading



HOLT

Low-friction rollers
smooth hoists

H2O Pro Feeder by Holt

Here's a product that's anything *but* a dog. Consider the poor bowperson. Most of the time, the best they can hope for is not to screw something up, thereby avoiding the wrath of the rest of the keyed-up crew. That's why this little bit of genius from Holt Allen is the stuff of dreams for those who prowl the pointy end.

A pull of the piston pin enables the hinged Pro Feeder to open, so you don't have to remove the headsail from the luff groove to run it through the feeder before a hoist. Simply pull the pin, open the Pro Feeder, insert the luff tape, snap it shut and tell the pit man to hoist away. Also simplifies and speeds up sail take downs.

Construction is 316 stainless steel with friction-reducing rolling balls so it'll take heaps of abuse while sparing the bowperson equal amounts of same. Handles 4mm to 7mm luff tape sizes.

Model 8681637 \$39.99

West Marine
We make boating more fun!

Find the H2O Pro Feeder by Holt at our
Alameda Sailing Superstore!

730 Buena Vista Ave. • 510-521-4865

We have 22 stores in Northern California.

Log onto westmarine.com or call **1-800-BOATING**
to find the store nearest you.

(619) 224-2349 • Toll Free (866) 341-6189

2330 Shelter Island Dr. # 207
San Diego, CA 92106
info@yachtfinders.biz
www.yachtfinders.biz



65' CUSTOM CC PH CUTTER, '94 169,000
Custom-designed and built by her first owner, *Brigadoon IV* has already successfully completed a circumnavigation and can easily be sailed by two.



48' SAMPSON KETCH, '82 \$79,000
Beautiful teak interior throughout, two private cabins, comfortable salon and seagoing U-shaped galley. *Windstrutter* is a lot of boat for the money!



38' C&C, '86 \$64,500
You'll find terrific value in this one-owner racer/cruiser. Her moderate beam and displacement provide speed, comfort, stowage and spaciousness.



36' BRENT SWAIN CUTTER, '88 \$68,000
Solidly built and beautifully appointed, this custom offshore vessel has great attention to detail, safety and all-new professionally installed systems.



36' CATALINA MKII, '01 \$134,900
West Wind will meet or exceed all of your expectations of a late-model Catalina 36. She's loaded with all the right stuff and she's clean to boot.



1979 ENDEAVOUR 43 CC \$162,000

Dream Ketch'r is an exceptional example of the Endeavour 43 and provides the best of both worlds: comfortable living space below combined with lots of modern equipment. She has everything you could want in a cruising boat and has been constantly upgraded and maintained. She is a pleasure to sail and has a high-aspect rig with good up-wind sailing capabilities not normally found in a bluewater cruising boat.



34' PETERSON, '78 \$33,000
This original-owner racer/cruiser yacht shows true care in her appearance and mechanical maintenance. *Revanche* will not disappoint you at this value price.



32' B-BOATS B-32, '95 \$40,000
This very well-rigged and successful racer offers an epoxy bottom, custom keel inspection window, a great racing sail inventory – and a trailer!



30' CATALINA, '80 \$24,000
A rare find these days, *Top Cat II* is a fantastic value at this price. Very clean, she also features the asked-for extras every buyer is looking for.



25' PACIFIC SEACRAFT, '77 \$14,500
Charming and functional, this ideal pocket cruiser offers graceful and sturdy sailing abilities, diesel engine, good sails, and air conditioning.



24' PACIFIC SEACRAFT DANA, '85 \$45,000
Spacious and well-thought out interior, oversized bronze ports, solid teak trim and good storage space add exceptional quality to this Creaklock design.

South Beach Riggers

Winning Technology for the Hot Race or the Casual Cruise

- Expert advice, sales and splicing of Vectran, Spectra, Technora, and Dacron by our certified splicer
- Professional survey and tune for your rig
- Standing and running rigging replacement
- Fabrication and hydraulics
- More than 100,000 miles racing and cruising experience



TWO LOCATIONS

399 Harbor Dr. • Clipper Marina • Sausalito • 415.331.3400
Pier 40 • South Beach Harbor • San Francisco • 415.974.6063

BRUNO'S
Island

Try out Bruno
with an overnight
stay for only
\$2.00*

Bruno's Island offers a security gated park-like setting with a relaxing ambience, friendly and helpful staff, and shaded parking. We currently have deep draft berths with easy access to the San Joaquin River that are perfect for the owners or dealers of 28 to 50-ft boats.

(916) 777-6084

Check us out at:
www.BrunosIsland.com

Boat yard on site offering complete marine service

On the scenic Delta Loop
1200 W. Brannan Island Rd., Ileton, CA

*New customer only - subject to availability.
Can not combine with any other offer. One time use per boat.

Ballenger Spar Systems, Inc.

Custom Racing and Cruising Spars
Expert Design and Consultation

- Carbon and Aluminum spars
- Rod and wire rigging
- Hi-tech and conventional halyards
- Spar kits, extrusion
- Repair and modification
- Custom fabrication, waterjet and CNC
- Hardware, sheaves, spreaders
- Bay Area pick-up and delivery
- **Discounts** on halyards, standing rigging, deck hardware, furlers, Navtec integral cylinders
- 30 years experience!

Call about Carbon Spars.
Masts • Booms • Poles

ballengerspars.com

831/763-1196

831/763-1198 (fax)

Pasta Pockets



Bulkhead Sheet Bags



Rail Mount Bags



Rail Mount Storage Bins

Blue Performance Organizers

Sailboats require a lot of spaghetti (lines) to manage the sails and controls. But how do you manage the spaghetti itself? The best solution we've found are Organizers from Blue Performance.

Unlike other cockpit organizers you may have tried, Blue Performance products won't come adrift while being hurriedly stuffed with lines in the heat of battle. Sailor-tested designs, stainless steel mounting hardware, UV-protected fabrics and strategically deployed bungee materials make these superbly engineered bags the best in the business.

A wide range of configurations and sizes are available to keep your boat's spaghetti where it should be so you and your crew can really cook!

 **West Marine**[®]
We make boating more fun![®]

Find Blue Performance Organizers at our
Alameda Sailing Superstore!

730 Buena Vista Ave. • 510-521-4865

We have 22 stores in Northern California.

Log onto westmarine.com or call **1-800-BOATING**
to find the store nearest you.

Custom Canvas & Interiors



The Gianola Family has been designing and fabricating custom canvas and interiors since 1969. Gianola & Sons offers you the best in quality, more choices, and personal service.



360 Gate 5 Road
Sausalito, CA 94965

(415) 332-3339

www.gianolacanvas.com

Take Our Boat Test. Please.



1. See a boat on MazMarine.com.
2. Add cost of plane ticket to Mazatlan.

3. Add up all costs in this column.

total: \$?



1. Find a comparable boat near you.
2. Add in all sales taxes. All of 'em.
3. Add in all requisite gear needed for off-shore cruising. All of 'em.
4. Add in your time, energy and costs to install and test both gear and boat.
5. Add in your time, energy and costs to sail her down to Mazatlan.
6. Add up all costs in this column.

total: \$?

Interesting comparison, isn't it? Try it. Do the math on any comparable yacht up in your neck of the woods, with one of our well-equipped and maintained off-shore yachts listed on MazMarine.com. Compare the specs. Add it up. The reality is that selecting a blue-water vessel from Mazatlan Yacht Sales, Mexico's biggest and best, and soon opening an office in La Paz, is often ultimately safer and less expensive. And you're cruising Baja now...not a year or two from now. Our yachts were sailed here by experienced owners. Each boat's gear has been selected, installed and ocean proven. Each awaits your inspection at our docks in Marina Mazatlan. Do it. Crunch the numbers and call us.



Ray Watson & Jeannette Sarrasin
 Toll Free 1 (888) 716-7430
 Phone & FAX: 011-52-669-913-3165
 E-mail: MazMarine@aol.com
 Compare our listings at: MazMarine.com



MARINA MAZATLÁN: MÉXICO'S NEW "HOME PORT"

MEXICO'S BIGGEST YACHT HARBOR KEEPS GETTING BETTER. THE NEW SINGLAR DOCK YARD FACILITY IS NOW OPEN HERE IN OUR SECURE HARBOR. MAZATLAN OFFERS SUPERIOR MARINE SERVICES, REPAIRS, RESTAURANTS, SUN, FUN, BEACHES... AND A GREAT CRUISING COMMUNITY.

**2007 WINTER CRUISING RATES:
NOV. 1 THRU MAY 31 '08.**

SIZE OF BOAT	0' TO 41'	42' TO 60'	61' TO 90'	OVER 90'
01 TO 10 DAYS	\$ 0.60	\$ 0.70	\$ 1.00	\$ 1.10
11 TO 29 DAYS	\$ 0.45	\$ 0.53	\$ 0.70	\$ 1.00
30 TO 90 DAYS	\$ 0.37	\$ 0.44	\$ 0.50	\$ 0.60
91 DAYS OR MORE	\$ 0.33	\$ 0.40	\$ 0.45	\$ 0.49

RATES, IN U.S. DOLLARS, ARE BASED ON DOCUMENTED LENGTH AND DO NOT INCLUDE 15 % TAX. 30 FOOT MINIMUM CHARGE.

marina mazatlán

MARINA MAZATLAN'S "THANKSGIVING" DINNER & DANCE

JOIN NEW AND OLD BAJA HA HA FRIENDS ON NOVEMBER 22nd. DINE, DANCE AND SWAP TALES WITH YOUR SOON TO BE BEST CRUISING BUDDIES AT MARINA MAZATLAN. YOUR NEW "HOME PORT."

FOR ALL RESERVATIONS, DETAILS AND FURTHER DISCOUNTS
 CONTACT: ELVIRA@MARINA-MAZATLAN.COM
 PHONE: 011-52-669-669-2936
 PHONE & FAX: 011-52-669-669-2937
 WWW.MARINA-MAZATLAN.COM

COAST MARINE

& INDUSTRIAL SUPPLY INC.

398 Jefferson St. San Francisco - On the Wharf.

Call **Bruce Becker** or **Clark Atkinson**
(415) 673-1923 (415) 516-4860

800-433-8050

Fax (415) 673-1927



LIFE RAFT Sales & Service



U.S.C.G. Approved Testing Facility

- ★ U.S.C.G. life raft facility for Solas commercial yacht and fisherman rafts
- ★ COMAR DEBARKATION LADDERS
- ★ COMAR PILOT LADDERS
- ★ COMAR WORK LADDERS
- ★ All U.S.C.G. approved

GUINNESS WORLD RECORD "World's longest tested ladder 320ft."

Major Distributor for:



Pains Wessex
Safety Systems



STEARNS

IN SAN DIEGO CALL OCEANS WEST 619 544-1900

SAUSALITO

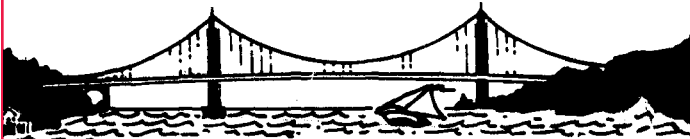

LIST MARINE INC.

- Full service engine shop
- We service all makes
- Dockside facilities
- Mobile service trucks



YANMAR
marine

P.O. BOX 2008 / 69 LIBERTY SHIP WAY
SAUSALITO, CA 94966
Adjacent to Schoonmaker Pt. Marina

415•332•5478

Relieves Gas Pains

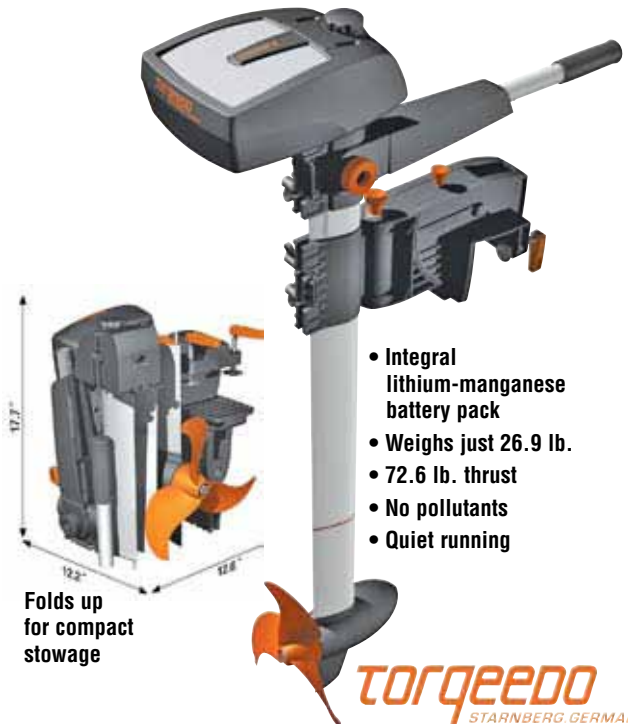

- Integral lithium-manganese battery pack
- Weighs just 26.9 lb.
- 72.6 lb. thrust
- No pollutants
- Quiet running

Folds up
for compact
stowage

TORQUEEDO
STARNBERG GERMANY

Travel 801 Electric Motor

Finally! A practical alternative to gas-powered outboards that's ideal for tenders, small keelboats and sportboats. The Torqeedo Travel 801 eliminates the mess and potential hazards of gas tanks along with oil changes, tune-ups, fumes and that infernal racket.

The Torqeedo combines an advanced lithium-manganese battery, highly efficient synchronous permanent magnet motor and variable pitch prop to produce thrust equivalent to a 2 hp combustion motor. It weighs a mere 26.9 lb. (with battery) and can be folded for easy stowage and transport.

If you're ready to say good-bye to gas pains, say hello to a better propulsion solution—the Torqeedo Travel 801 Electric Motor.

Long & Short Shaft versions available. **\$1599.00**

West Marine[®]
We make boating more fun![®]

Find the Torqeedo Travel 801 Electric Motor at our
Alameda Sailing Superstore!

730 Buena Vista Ave. • 510-521-4865

We have 22 stores in Northern California.

Log onto westmarine.com or call **1-800-BOATING**
to find the store nearest you.

SPECIALIZING IN BLUEWATER CRUISING YACHTS



65' Nautor Swan, '75, \$695,000



52' Tayana aft cockpit, '91, \$325,000



48' Hans Christian, '88, \$299,000



42' Catalina (3 to choose from)



57' McKinna Pilothouse, '00, \$599,000



49' Grand Banks, '95, \$695,000



37' Pacific Seacraft Crealock, '81, \$115,000



40' Passport, 2 to choose from

SAIL		POWER	
65' Swan, '65	\$695,000	41' Jeanneau Sun Legend, '86	\$79,000
63' Dynamique Elite cutter, '83	\$325,000	41' Master Mariner Neptune, '85	\$110,000
60' Maple Leaf pilothouse, '87	\$324,000	40' Jeanneau Sun Fast sloop, '02	\$189,000
53' Amel Mango cutter ketch, '81	\$175,000	40' Passport, '81	\$110,000
52' Tayana aft cockpit, '91	\$325,000	40' Passport cutter, '86	\$149,900
50' Hudson Force Venice ketch, '87	\$219,000	40' Baba cutter, '83	\$139,000
50' Centurion Orion, '84	\$129,000	40' Beneteau, '95	\$126,500
48' Hans Christian, '88	\$299,000	40' Fortuna Island Spirit 401	\$469,000
47' Beneteau 473 3-cabin	\$260,000	39' Cavalier, '80	\$75,000
46' Catamaran Choy Seaman, '91	\$174,900	38' Ingrid cutter sloop, '81	\$79,000
46' Jensen Marine Cal 2-46, '72	\$79,000	38' Downeast, '77	\$59,000
45' Liberty 458 CC cutter, '83	\$175,000	38' Pearson cutter, '84	\$89,500
44' Jeanneau Sunkiss, '84	\$150,000	38' Catalina sloop, '84	\$59,900
44' Formosa cutter, '87	\$149,000	37' Irwin, '79	\$59,900
44' Kelly Peterson cutter, '76	\$123,000	37' Pacific Seacraft, '81	\$115,000
43' Beneteau 432 sloop, '87	\$99,000	36' CS Yachts LTD Canadian, '84	\$69,000
42' Beneteau First, '82	\$74,000	36' Custom C-Crest ketch, '88	\$59,000
42' Catalina sloop, '90	\$120,000	34' Columbia sloop, '70	\$27,000
42' Catalina MkI, '94	\$128,000	34' Coronado sloop, '74	\$36,000
42' Catalina sloop, '89	\$115,000	34' Ericson, '79	\$17,500
42' Westsail, '74	\$60,000	32' Brandlmayer/Spencer, '71	\$14,500
42' Hylas sloop, '87	\$159,000	26' McGregor, '98	\$22,000
41' Hunter, '98	\$159,900		
41' Dufour Gib Sea, '85	\$65,000		



VALLARTA YACHTS SA DE CV
Exclusive Mexico Dealer for Sabre and Back Cove Yachts

57' McKinna pilothouse, '00	\$599,000	38' Californian aft cabin trawler, '75	\$84,500
52' Hatteras convertible sedan, '84	\$349,999	38' Bayliner, '92	\$110,000
49' Grand Banks motoryacht, '95	\$695,000	36' Blackfin sportfisher, '88	\$155,000
48' Offshore Camargue yacht, '91	\$350,000	32' Fjord sportfisher, '70	\$70,000
46' Lien Hwa motoryacht, '87	\$159,000	30' Albemarle Express 305, '02	\$179,000
46' Hatteras convertible SF, '77	\$250,000	29' Back Cove, '07	Inquire
43' Albin Marine trawler, '79	\$128,000	27' Skipjack cuddy sportfisher, '85	\$34,000
		18' Stripper Sea Swirl, '03	\$26,000

Nick and Carol Rau
Paradise Village Marina
Ph/Fax: 011-52-322-297-2249
Local Cell: 044-322-227-2944
US: 314-667-4111 (rings in MX)

www.vallartayachts.net
nick@vallartayachts.net



Society of Accredited Marine Surveyors®

Serving Northern California

Al Blair, SA
415.456.3154
blairsurvey@msn.com

Jesse Brody, SA
415.342.0757
jesse@baymarinesurvey.com

Alan Hugenot, AMS®
415.531.6172
captainhugenot.com

Tom List, AMS®
415.332.5478
listmarine@yahoo.com

Jack Mackinnon, AMS®/SMS
510.276.4351
surveyjack@aol.com

Francoise Ramsay, SA
415.497.7409
framsay@comcast.net

Randell Sharpe, AMS®
877.337.0706
rsharpe@alamedanet.net

Terry Tucker, SA
510.381.1925
ttucker100@sbcglobal.net

Terry Tupper, SA
415.722.7695
bluwater@juno.com

Rick Whiting, SA
415.740.2924
captain_rick@sbcglobal.net

R.J. Whitfield & Assoc, AMS®
800.344.1838
rjwsurvey.com

BETA MARINE

SMOOTHER...
QUIETER!

Our engines idle smoother and quieter because of our high inertia flywheel. This is one of the many Beta Marine exclusive features that make our diesel engines easier to live with.



What a Concept! It is engineered to be easily serviced.

Beta Marine superb propulsion engines, using Kubota diesel 10-90hp including our famous Atomic 4 replacements.

Also available: Marine Generators up to 30 kw.

Regional Dealer:

BETA MARINE US, LTD. **HIRSCHFELD YACHT LLC**

P.O. Box 5, Arapahoe, NC 28510
www.betamarine.net

265 Gate 5 Rd, Sausalito, CA 94965
www.engineerite.com

877-227-2473 • 252-249-2473

415-332-3507

info@betamarinenc.com



CLIPPER YACHT HARBOR

Sausalito's Only
Full Service Marina

www.clipperyacht.com

310 Harbor Dr., Sausalito, CA 94965

(415) 332-3500

800 Slips 20-60 ft • Dry Storage Available

- Fuel Dock
- Bait & Tackle Shop
- Sport Fishing
- Restaurants
- West Marine
- Launch Ramp
- Pump Out
- Laundry Facility
- Private Restrooms/Showers
- Anderson's Boat Yard
- Guest Slips Available

"Your Destination for a Full Service Marina"

Artistic Forgeries



Forged Shackles

When it comes to shackles, you shouldn't just accept a forgery, you should *insist* on it! Shackles have a tough job to do (usually holding expensive bits of your boat together), so it makes sense to buy the toughest, strongest, most reliable shackles made. Those would be the brilliant forgeries by Wichard.

These extraordinary shackles are created by drop forging 17.4 PH stainless steel, then painstakingly polishing them to a brilliant finish that defies the crevice corrosion which can cause lesser shackles to fail with catastrophic consequences.

If you want to skimp on something, go buy a forged painting. But don't skimp on something as important as a shackle. Insist on forged shackles by Wichard.

West Marine
We make boating more fun!

Find Wichard Forged Shackles at our
Alameda Sailing Superstore!

730 Buena Vista Ave. • 510-521-4865

We have 22 stores in Northern California.

Log onto westmarine.com or call **1-800-BOATING**
to find the store nearest you.

Want the right sailing school?

Choose the award winning sailing school that stands out above the rest

- ★ Learn to sail on boats specifically designed for training
- ★ Take classes from three ideal locations
- ★ Have access to the largest, newest and best equipped fleet
- ★ After your training you'll be qualified to charter boats with wheel steering and inboard diesel engines, whether you're a member or not

Don't sell yourself short.
Get the best education
and sail the best fleet.

Winner Prosser Award

For Excellence in Sailing Education



www.clubnautique.net



Alameda:
800 343-7245
Richmond:
866 606-7245
Sausalito:
800 559-2582

Call today for your free brochure with CD-rom

CALENDAR

Non-Race

Oct. 3 — *Latitude 38* Mexico-Only Crew List and Baja Ha-Ha Party at Encinal YC, 6-9 p.m. For more info, check out www.baja-haha.com and www.latitude38.com.

Oct. 3, 10, 17, 24, 31 — Wednesday Yachting Luncheon Series at St. Francis YC, 12-2 p.m., \$13.50. Enjoy lunch and a dynamic speaker every Weds. All YC's members welcome. More info under the 'Events' tab at www.stfyc.com.

Oct. 3, 17 — Pt. Fermin Singles Sailing YC invites singles to two monthly meetings. 6 p.m. at Acapulco Restaurant in San Pedro. Info, (310) 427-4817 or www.pfsyc.com.

Oct. 4-Nov. 15 — San Francisco Power Squadron's Boating Safety Course at Oyster Point YC on Thursdays, 7:30-9:30 p.m. Info, Janis at (650) 871-4447 or info@sfpd.org.

Oct. 4 — Light the Night Walk to benefit the Leukemia and Lymphoma Society, 5 p.m. at Oyster Point Marina. Info, email jasperc@lls.org or (408) 271-8312.

Oct. 4-9 — Fleet Week, including the Blue Angels. The sailors are in! Details, www.fleetweek.us.

Oct. 5 — Ha-Ha Cruisers' Bash at Sausalito West Marine, 5-7 p.m. Share snacks and stories. Info, (415) 332-0202.

Oct. 5-7 — Cruiser's Expo 2007, seminars for cruisers sponsored by Newport Beach West Marine. Learn about First Aid, Anchoring, Cruising Mexico, Diesel Basics, Safety and Battery Basics. Call Jacques Pane at (949) 644-9530.

Oct. 6 — Swap Meet at Chula Vista Marina, 7 a.m.-1 p.m. Info, (619) 691-1860 or www.chulavistamarina.com.

Oct. 6-7 — 15th Annual Northern California Women's Sailing Seminar at Island YC. A qualifier in the 'unofficial' *Latitude 38* Women's Circuit. Info, www.iyc.org/wss.htm.

Oct. 7-28 — Free sailing at Pier 40 every Sunday courtesy of BAADS. Info, (415) 281-0212 or www.baads.org.

Oct. 11 — If you want to meet other single sailors, learn to sail or need crew, Single Sailors Association's monthly meeting is at Oakland YC, 6:30 p.m. Info, www.singlesailors.org.

October 1977 — It Was Thirty Years Ago, from an article titled *Beer*:

Beer. It can make you fat, it can make you drunk, and it can make you friends. On her month-long cruise to Southern California and the Channel Islands, the ketch *Lily* carried a large cargo of beer. It made the crew fat, sometimes it made them drunk, but best of all, it made them some special friends. We joined *Lily* in Marina del Rey when she was making some changes in crew.

Two days later we were lying in silence on the sloping hills of Santa Cruz Island, enjoying the panorama of history before our eyes. Several miles to the south lay Anacapa Island, forced up from the depths of the ocean a million years ago. A few hundred yards to the west were Indian caves, active homes only a few hundred years ago. Along the ridges to the north were a number of the 38 neat stacks of boulders and rocks carefully put there near the turn of the century by prisoners in an attempt to clear the stony soil for cultivation. Just to the west was a rusted horse-drawn grader from the Depression Era. And moments later, coming right at us was the supply plane, the 12-passenger Islander, vintage 1970s.

Traditionally, the view of the cobalt water and brown islands has been the province of Indians, prisoners, smugglers, ranchers, and a few oil explorers. Visitors are not allowed on Santa Cruz Island. We were there only as a result of good fortune, anchoring at Scorpion, and having a goodly supply of beer.

The eastern portion of Santa Cruz Island is used for raising sheep. Fidel is the foreman, and has the help of Eddie, Richard and Primitivo. Six or seven times a year they round up the

NELSON *Yachts*

SELL WITH US!

www.nelsonyachts.net
(510) 337-2870

Chad Freitas Ruth Scott
Steve Coghlan, Broker



**OLSON 40
1982**

Strong, swift, elegant.
Legendary performance
and construction.

\$78,000



**DEFIANCE
41' SHOCK,
1984**

Ready to race.

\$68,000



**VAGABOND
LANDFALL 39,
1975**

Beautiful restoration,
excellent condition,
professionally
maintained.

\$89,900



**FARR 40,
1984**

Clean, well built
custom racer.

\$59,000



**34' PETERSON,
1980**

New bottom,
Andrews designed
keel, tall rig.

\$39,000



REDUCED

**34' CHINOOK,
1967**

Gracious Lady

Traditional lines,
many spares,
inboard diesel.

\$18,000

SOLD: 47' BAYLINER • 43' NAUTICAT • 41' HALBERG-RASSY
40' SEA RAY • 38' FU HWA • 37' LEGEND • 37' HUNTER
37' ISLANDER • 36' HUNTER • J/32 • 30' CATALINA
27' ERICSON • 27' HUNTER • 23' CAMPION

SAIL

50' Hudson Force, '81.....	189,000	27' Ericson sloop, '73.....	SOLD
47' Cheoy Lee, '74.....	125,000	27' Catalina, '79.....	7,500
41' CT Formosa Yankee Clipper, '74..	47,000	27' Hunter, '77.....	SOLD
40' Fast, '80.....	19,900	27' Nor'Sea, '79.....	39,000
40' Olson sloop, '82.....	78,000		

POWER

40' Farr custom racer, '84.....	59,000	35' U.S. Military Amphibious, '63.	90,000
39' Vagabond Landfall cutter, '75.....	89,900	34' Silverton Convertible, '85.....	56,000
37' Islander sloop, '68.....	SOLD	32' Uniflite, '76.....	24,400
34' Chinook, '67.....	18,000	31' Rinker Fiesta, '00.....	69,000
34' Peterson cruiser, '80.....	39,000		

NEW HUNTERS

32' Columbia 5.5 Sabre, '67.....	7,000	21.5' Hunter 216, demo '04.....	13,499
30' Carter, '76.....	19,950	17' Hunter 170, new '06.....	7,599
29' Cal 2-29, '72.....	13,900	14.5' Hunter 146, new '06.....	4,999
28' Albin sloop, '82.....	14,900	14' Hunter 140, new '06.....	4,499
28' Wylie Hawkfarm, '78.....	6,000	10' Hunter Xcite, new '05.....	2,599

Back Cove Yachts

Introducing the **NEW**
BACK COVE 33



Back Cove 29



Back Cove 26

Call Sail California to find out how
we can put you in the driver's seat.

SAIL
California

Web page: www.sailcal.com
Email: info@sailcal.com

NEWPORT BEACH
(949) 675-8053
FAX (949) 675-0584

ALAMEDA
(510) 523-8500
FAX (510) 522-0641

CALENDAR

sheep for various purposes — shearing, mating, separating, and herding for the trip to the mainland. The rest of the time the crew on the island rides fences, repairs the incredible variety of ancient mechanical equipment, raises chickens, grows fruits and vegetables, and in general takes care of what needs to be taken care of.

What needed attention when we anchored was the pier at Scorpion. Last Thanksgiving, Santa Ana winds from the deserts hit the island at up to 75 knots, destroying six boats on the island, and also destroying the pier in the process. The pier is the place where the *Vanquero II* from Santa Barbara puts in to take on livestock for the trip to the mainland. Richard and Eddie were rebuilding the pier when we arrived; pulling out parts from the water and welding them back into a functional boarding facility. It was hard work on the warm day, and the equipment they had to work with consisted of mostly strength and ingenuity. It was hot and we had cold beer. Clint and Max rowed in at lunchtime and gave Richard and Eddie a six-pack. They in turn invited the crew on *Lily* for a tour of the ranch when they were done for the day.

The four of us didn't need encouragement, and at dusk we got pooped off-loading ourselves and a jug of Growers wine in a ferocious surf. All six inches of it.

Walking up the valley to the main ranch grounds was a stroll into the past — and a pleasing one. By city standards, everything was somewhat primitive, but it worked, or could be made to work, or could be used for parts. No one on the island seemed to either want or need any more. There was a conspicuous absence of colored packages and knick knacks of the consumer society. God, it was great!

Oct. 12-14 — Beneteau Rendezvous at Passage Yachts in Point Richmond. Info, (510) 236-2633.

Oct. 13 — Bird Boat 85th Anniversary celebration at SFYC, starting at 1 p.m. See the flock at the guest dock and watch vintage films, then stay for dinner. Info, www.mastermariners.org.

Oct. 13, 27, Nov. 3 — Free sail on gaff-sloop *Polaris* at Spaulding Wooden Boat Center in Sausalito. RSVP at www.spauldingcenter.org or (415) 332-3179.

Oct. 14 — Oakland YC Open House for prospective members, 9 a.m.-Noon. Stay for brunch, \$9.50. RSVP at (510) 522-6868 or cwong@oaklandyachtclub.com.

Oct. 14, 21 — Cal Sailing Club will give free sailboat rides at Berkeley Marina, 1-4 p.m. Info, www.cal-sailing.org.

Oct. 18 — Red Wine & Rubber Boots Tall Ship Education Academy Benefit Reception on the ferryboat *Eureka* at Hyde St. Pier, 6-9 p.m. Info, www.tallshipacademy.org.

Oct. 20 — Bay Fest at McGrath Yachts in Sausalito. Call (415) 331-5020 or go to www.mcgrathyachts.com for info.

Oct. 20 — 19th Annual Sea Music Concert Series kicks off aboard *Balclutha* at Hyde St. Pier with master sea chantey singer John Roberts. Tickets \$14 (\$12 for SF Maritime Park members) or \$24 for the season. Call (415) 561-6662 ext 33.

Oct. 20 — Maritime Library Friends' 25th Annual Symposium, 10 a.m.-5 p.m. \$35 advance tickets (\$45 at door) include box lunch and reception. Info, (415) 561-7040.

Oct. 20 — Trees to Sea Harborfest, a Santa Cruz Harbor 'open house'. See www.santacruzharbor.org for more info.

Oct. 21 — Ha-Ha Welcome to San Diego Party at Downwind Marine, Noon-4 p.m. Info, www.baja-haha.com.

Oct. 21 — Get ready for the Pacific Cup with PCYC's first pre-race seminar at Berkeley YC, 8:30 a.m.-5:30 p.m. \$35 fee includes lunch and pupus. Info, www.pacificcup.org.

Oct. 23 — How to Use a Chart class by Santa Clara Power Squadron at Wilcox HS, 7 p.m. Info, (408) 225-6097.

Oct. 25 — Windvane Steering seminar at Downwind Marine

EVENTUALLY, EVERYTHING WEARS OUT.

Fall Savings -
Lowest Prices -
of the Year!



Quantum Pacific
1230 Brickyard Cove Road
Point Richmond, CA 94801
sanfrancisco@quantumsails.com
510.234.4334

Los Angeles
222 West 'D' St.
Wilmington, CA 90744
mtaylor@quantumsails.com
310.518.2842

San Diego
2832 Canon St.
San Diego, CA 92106
reynolds@quantumsails.com
619.226.2422

SHIFT
THE
ANTICIPATE

WE'RE JUST NOT SURE HOW LONG EVENTUALLY IS.



How long will our cruising sails last? We still don't know.
Quantum. The world's most durable cruising sails.



Nothing Beats a J/Boat!

**J/122 TKO wins Rolex
Big Boat Series IRC-C!**



Now at our docks.



See the J/124 popular daysailer.



See the J/109 popular racer/cruiser.



What's different about a J/Boat? You have to sail it to believe it. Call us to find out about the J/Boat experience.

SAIL
California

Web page: www.sailcal.com
Email: info@sailcal.com

SAIL CALIFORNIA
NEWPORT BEACH
251 Shipyard Way
Cabin A
(949) 675-8053
FAX (949) 675-0584

SAIL CALIFORNIA
SAN FRANCISCO BAY
1070 Marina Village Pkwy,
#108, Alameda
(510) 523-8500
FAX (510) 522-0641

SAIL NORTHWEST
SEATTLE
7001 Seaview Ave., NW
Suite 140
(206) 286-1004
FAX (206) 286-1353

CALENDAR

in San Diego. Sign up at Downwind Marine.

Oct. 26 — Full moon on Tuesday night.

Oct. 27 — Free Diesel Engine Maintenance seminar at KKMI Boathouse, 9 a.m. Call Ginger for info or to RSVP, (510) 235-5564 or www.kkmi.com.

Oct. 27 — Diesel Engine Maintenance class at SF Maritime's Boat Shop, \$100. Info, www.maritime.org/cal-boat.htm.

Oct. 27 — Haunted Harbor Festival and Boat Parade at Jack London Square, 4-8 p.m. Info, www.jacklondonsquare.com.

Oct. 28 — Brisbane Marina Festival, 10 a.m.-4 p.m. Boat rides and much more for the family! Info, (650) 583-6975.

Oct. 29 — Baja Ha-Ha XIV Cruisers Rally begins!

Oct. 30 — Great Pumpkin BBQ at Sausalito West Marine, 11-2 p.m. Ghouls welcome. Info, (415) 332-0202.

Oct. 31 — Scare up a good time!

Nov. 3 — Go behind the scenes to tour the SF Maritime Park's Small Craft Collection. Free. Info, www.maritime.org/cal-boat.htm or call (415) 561-6662.

Racing

Oct. 5 — Big Team Regatta, an all-day corporate sailing challenge and party held at OCSC to raise money for Treasure Island SC's Youth and Adaptive Sailing programs. To learn more go to <http://bigsf.gelcorp.com>.

Oct. 5-7 — Southwestern YC's 44th Annual San Diego to Ensenada International Yacht Race. Info, (619) 222-0438 or www.southwesternyc.org.

Oct. 6 — 4th Annual VNA & Hospice Regatta on Monterey Bay. MPYC, www.mpyc.org or (831) 402-3181.

Oct. 6 — Wallace Cup, a PHRF championship for East Bay clubs. OYC, www.oaklandyachtclub.com.

Oct. 6 — Hardehine Regatta for Snipes and Mercuries. RYC, www.richmondyc.org.

Oct. 6-7 — SSS Vallejo 1-2, a mellow way to end the short-handed season. Info at www.sfbaysss.org.

Oct. 6-7 — Fall One Design for Melges, Etchells, IOD and J/24 fleets. SFYC, www.sfyf.com or (415) 789-5647.

Oct. 7 — El Toro Stampede. RYC, www.richmondyc.org.

Oct. 7 — Berkeley YC Chowder Series begins and continues every Sunday through March, except during Berkely Midwinters. Paul, (510) 540-7968.

Oct. 12-14 — International Master's Regatta, a J/105 regatta/reunion for seniors. StFYC, www.stfyf.com.

Oct. 13 — YRA-OYRA Junior Waterhouse, RYC. Info, www.yra.org.

Oct. 13 — Ruth Gordon Schnapp Women's Regatta, a new addition to the local crop of races for women skippers. GGYC, call Gary Salvo at (916) 363-4566 or garysalvo@ggyc.com.

Oct. 13 — El Toro Corkscrew Slough Regatta. Sequoia YC, www.eltoroyra.org.

Oct. 14 — Women Skippers Regatta, a fundraiser for Tall Ship Semester for Girls. SYC, www.syconline.org.

Oct. 19-20 — IOD Team Races, SFYC hosts Marblehead (3 boats each team). SFYC, www.sfyf.com or (415) 789-5647.

Oct. 20 — YRA-HDA Yankee Cup/ODCA Champion of Champions, IYC. Info, www.yra.org or (415) 771-9500.

Oct. 20-21 — Jessica Cup, fleet racing for big woodies. StFYC, www.stfyf.com. Yes, these are the correct dates!

Oct. 21 — Lady Skipper's Race, PresYC. For more info, www.presidiodyachtclub.com.

Oct. 27 — Red Rock Regatta and Costume Party. TYC, www.tyc.org.

Oct. 27-28 — Fall Dinghy & Olympic Classes. StFYC, www.stfyf.com.

Oct. 27-28 — Great Pumpkin Regatta, a Halloween tradi-

WE WANT TO SELL THESE BOATS – WE WANT TO SELL YOUR BOAT! CALL TODAY!

SAIL *California*

WE HAVE A J/BOAT FOR YOU!

Don't wait another day to have the J/Boat Experience, visit our sales dock and choose from pre-owned J/105s, J/109, J/120, J/42 and J/44



Andrews 56, 1992

Cipango

Looking to win the Pacific Cup? This is your ride!

Asking **\$389,000**



SISTERSHIP

J/100, 2005

Crewcut

100% perfect for a day's sail. Whether your singlehanded or taking the "gang" this boat will give you performance and comfort. Crewcut is beautifully maintained and a very well equipped boat.

Asking **\$129,900**

Elan 40, 2004
Tupelo Honey
This is a great sailing boat with an excellent record on the race course and could easily convert to a fabulous cruising boat.
Asking **\$259,000**



Back Cove 29, 2005
Diamond Lil
Style, grace and performance, what more could you want?
Asking **\$199,000**



Hunter 450, 2000, Fall Asea
Priced to sell, ultimate cruiser and/or liveboard. Palatial interior (standing hdm over 6.5'), large cockpit, great swim platform, spacious decks. Ready for year-around fun. Asking **\$229,000**



Andrews 56, 1994, Charisma
This performance cruising boat offers speed and comfort with the allure for adventure. Call today to fulfill your cruising dreams. Asking **\$395,000**



J/105, Wianno, 1998
See this classic tiller boat, race ready on our sales dock today. Asking **\$87,000**



J/44, 1990, Phoenix
The perfect sailboat – liveboard comfort, easily managed by two, offshore durability and speed to win Fastnet and Sydney-Hobart. Asking **\$239,000**

56' Andrews 56, '92, <i>Cipango</i>	389,000
56' Andrews 56, '94, <i>Charisma</i>	\$395,000
53' HC-50, <i>Break n' Wind</i> , '01.....	Reduced \$498,000
53' Andrews, '90, <i>Artemis</i> **.....	Reduced \$349,000
52' Santa Cruz, '00, <i>Natazak</i>	Sale Pending \$629,000
45' Hunter 450, '00, <i>Fall Asea</i>	\$229,000
44' J/44, '90, <i>Phoenix</i>	\$239,000
40' J/120, '98, <i>Hot Tamale</i>	Reduced \$219,000
40' J/120, '95, <i>Attitude</i> **.....	\$199,000
40' Tripp, '92, <i>Snake Oil</i> **.....	\$89,900
40' Elan, '04, <i>Tupelo Honey</i>	\$259,000
38' Ericson 38-200**.....	\$95,000

37' Pacific Seacraft Crealock 37, <i>Zest</i>	Sale Pending \$134,900
36' J/109, '03, Hull #43**.....	Reduced \$209,000
35' J/35, '90, <i>Unusual Attitude</i> **.....	Reduced \$59,900
35' J/35, '84, <i>Courageous</i> **.....	\$42,000
35' J/105, '02, <i>Rum Tum Tugger</i>	SOLD
35' J/105, '99, Hull #255, <i>Rodster</i> **.....	\$119,000
35' J/105, '99, Hull #235, <i>Life Is Good</i> **.....	\$105,000
34' J/105, '98, <i>Wianno</i>	Reduced \$87,000
34' J/34, '85, <i>The Zoo</i> **.....	Reduced \$29,900
33' J/100, '04, Hull #9, <i>Brilliant</i> **.....	\$134,900
33' J/100, '05, Hull #14, <i>Crewcut</i>	New Listing \$129,900
33' J/100, '05, Hull #17**.....	\$125,000

32' Melges, <i>Emotional Rescue</i>	Reduced \$74,500
30' J/92, '93, <i>Zippy</i> , Waukesha, WI.....	\$54,500
29' J/29, '81, <i>Macs</i> *.....	\$26,900
29' J/29, '84, <i>Jolly J</i> *.....	\$25,000
29' J/29, '84, <i>Salsa</i> **.....	Reduced \$17,900
29' Back Cove, '05, <i>Diamond Lil</i>	New Listing \$199,000
26' J/80, '00, <i>Risky Business</i> **.....	Reduced \$32,000
26' J/80, '01, <i>Flying J</i>	New Listing \$36,500
24' J/24, '05, Hull #5453**.....	\$35,000
20' Harbor 20, '04**.....	\$26,500
20' Clark, '05, <i>Tahoe 20</i> **.....	\$44,000
19' Alerion Cat, '98, <i>Whiskers</i> **.....	Reduced \$19,000

YACHTWORLD.com

**OPEN BOAT WEEKEND
OCTOBER 13-14**

**J
Net**

* Indicates So. California Boats
** Indicates Seattle Boats

SAIL *California*

Web Site: www.sailcal.com
Email: info@sailcal.com

NEWPORT BEACH
251 Shipyard Way
Cabin A
Newport Beach, CA 92663
(949) 675-8053
FAX (949) 675-0584

ALAMEDA
1070 Marina Village Pkwy
#108
Alameda, CA 94501
(510) 523-8500
FAX (510) 522-0641

**SEATTLE
SAIL NORTHWEST**
2130 Westlake Ave. N.
#3
Seattle, WA 98109
(206) 286-1004



Bottom Painting Packages
where the price we quote
is the price you pay!

*"The quality of the hull and
bottom painting exceeded
my expectations."*



THE BEST VALUE IN THE BAY NO MATTER THE L.O.A.!



*"Each time the end result
exceeds our expectations."*

*"Thanks for the thorough 101
tutorial about my engine."*



*"I took on several projects my-
self which gave me the chance
to work alongside the KKMI
Team. Everyone was competent,
friendly, helpful and showed
real interest in my project."*





KKMI voted 'Boatyard of the Year' by the American Boat Builders and Repairers Association.

"I will recommend KKMI to my friends."



KKMI Maritime Full Service Yard

"Your team of professionals treat people with respect"

"Hats off to everyone; I couldn't be more satisfied"



KKMI Maritime Electronics

"I can't tell you how much more efficient this facility is versus any other. Why would you go anywhere else?"



Ask us about discounted Bottom Painting Packages.

Keefe Kaplan Maritime, Inc
530 West Cutting Blvd.
Office Ph (510) 235-KKMI
kkmi.com * yard@kkmi.com

CALENDAR

tion. RYC, www.richmondyc.org or (510) 237-2821.

Oct. 27-Nov. 3 — 21st Annual Pro Am Regatta on Virgin Gorda, hosted by Bitter End YC. What a great excuse to go to the Caribbean! Info, www.beyc.com.

Nov. 2-9 — Long Beach to Cabo San Lucas Yacht Race. LBYC, www.lbyc.org, raceoffice@lbyc.org or (562) 493-5173.

Nov. 4 — Jack & Jill+1, the women-skipped triple-handed race on the Estuary. A qualifier in the 'unofficial' Latitude 38 Women's Circuit. IYC, www.iyc.org.

Nov. 13 — The Big Sail: Stanford vs. Cal in J/105s. More fun than football! StFYC, www.stfyc.com.

Nov. 15 — YRA Year-End Trophy Party.

Nov. 17-18 — Pre-Holiday Regatta for PHRF and one design classes fielding five or more entries. SFYC, www.sfyc.org.

Remaining Beer Can Regattas

BALLENA BAY YC — Friday Night Grillers: 10/12, 10/26. Sarah, (510) 685-0021.

CAL SAILING CLUB — Year-round Sunday morning Lido 14 races, intraclub only. Ed, racing_chair@cal-sailing.com.

COYOTE POINT YC — Every Wednesday night through 10/17. Mark Misura, (650) 347-1505.

HP SAILING CLUB — El Toro Races on Stevens Creek Reservoir. Every Wednesday night through 10/31. Dan Mills, (831) 420-3228 or www.hpsailingclub.org.

LAKE TAHOE WINDJAMMERS YC — Every Wednesday night through 10/24. Kurt Rasmussen, (530) 541-1129.

SANTA CRUZ YC — Wet Wednesdays, every Weds. night during Daylight Saving Time. Larry, (831) 423-8111.

SEQUOIA YC — Every Wednesday night through 10/10. Ron Brown, (650) 430-5567.

SOUTH BAY YRA — Summer Series: 10/13, 10/14. Larry Westland, (510) 459-5566.

Please send your calendar items by the 10th of the month to calendar@latitude38.com. If you're totally old-school, mail them to *Latitude 38* (Attn: Calendar), 15 Locust Avenue, Mill Valley, CA, 94941 or fax them to us at (415) 383-5816. But please, no phone-ins! Calendar listings are for marine-related events that are either free or don't cost much to attend. The Calendar is not meant to support commercial enterprises.

October Weekend Currents

date/day	slack	max	slack	max
10/06Sat		0112/3.7E	0501	0817/3.3F
	1117 2249	1424/2.3E	1719	2015/2.4F
10/07Sun		0212/3.6E	0549	0901/3.4F
	1155 2346	1502/2.7E	1809	2107/2.8F
10/13Sat		0021/3.3F	0341	0600/2.4E
	0917 2200	1205/2.3F	1449	1809/4.2E
10/14Sun		0100/3.1F	0427	0640/2.1E
	0946 2241	1239/2.0F	1517	1849/4.1E
10/20Sat		0626/2.7F	0953	1205/1.8E
	0317 1540	1814/1.7F	2054	
10/21Sun		0012/3.5E	0408	0715/3.0F
	1034 2205	1301/2.4E	1637	1917/2.2F
10/27Sat		0527/3.0E	0833	1126/3.2F
	0307 1411	1738/5.8E	2128	
10/28Sun		0034/4.5F	0405	0618/2.6E
	0919 2223	1213/2.9F	1455	1827/5.7E

**ATTENTION CRUISERS!
MEXICAN LIABILITY INSURANCE ONLINE**

**Official Sponsor
2007 BAJA HA-HA**

MARINERS
GENERAL INSURANCE GROUP

Now with six offices offering you local insurance service and global insurance coverage.

SEATTLE
Joe Cable
(800) 823-2798
(206) 281-8144
Fax (206) 281-8036

NO. CALIFORNIA
(800) 853-6504
(650) 373-0595
Fax (650) 548-1585
email: boomeins@aol.com
Lic. # OA99058

L.A./ORANGE COUNTY
Craig Chamberlain
(800) 992-4443 • (949) 642-5174
Fax (949) 642-0252
Lic. # OD36887

SAN DIEGO
Henry Medina
(800) 639-0002
Fax (619) 226-6410
Lic. # OA96346

BRADENTON, FLORIDA
Jerry Norman
(800) 914-9928
Lic. # EO51940

**New!
PUERTO VALLARTA**
(949) 642-5171

We insure racers and cruisers all over the world with prompt, reliable service.

www.marinersinsurance.com

- Sail & Power
- Fishing Boats
- Charter Boats
- Liveaboards
- Marine Businesses
- Tugboats
- Cargo
- Offshore Cruising

MARINERS
GENERAL INSURANCE GROUP

It's A Mariner's Fact:
Mariner's General Insurance insures cruising sailboats all over the world... are you heading out?

Great Sails Great Sail Care!

Certified Quality

All North Quality Sail Care meets North Manufacturing Blue Book Quality Standards for construction and materials... *even if your sail was made by another sailmaker.*

Custom Sail Washing

North soaks sails in a proprietary solution instead of tumble washing. The result is less wear and a cleaner sail (tough stains are pressure washed).

Expert Upgrades

- Expert Recuts and Reshaping
- Furling & Reefing Systems
- FullBatten Upgrades... and more!

All performed by experienced experts who get it right!

Act now and save!

This coupon redeemable toward sail care at the nearest participating North service facility. *Limited to one coupon per customer.*

\$25.00

Valid on service orders received by 11/30/07



To redeem coupon, cut out this ad and bring it to the nearest participating North Certified Sail Care facility with your sail service order. *Offer limited to one coupon per customer.*

Better by Design

Sausalito 415-339-3000
San Diego 619-224-2424
Long Beach 562-795-5488
Channel Islands 805-984-8100
Marina Del Rey 310-827-8888
www.northsails.com

FAR-OUT GENNAKER SAILING...

Now available
in carbon!



...with an extendable
Seldén gennaker bowsprit

- Gives the gennaker more clear air
- Facilitates rapid gybing
- Always ready for quick extension
- Makes for fast and efficient gennaker handling
- Can be fitted to most yachts
- Complete kit for deck mounting

www.seldenmast.com

 **SELDÉN**
for sailing

Rig solutions for dinghies, keelboats and yachts. Aluminium and carbon spars. More than 750 authorised dealers worldwide.

Seldén Mast Inc. Tel 843-760-6278, info@seldenus.com

LETTERS

↑↓AIS IS WORTH ITS WEIGHT IN GOLD

Today, while 300 miles east of the Chagos Archipelago, we had way too much excitement with an Indian bulk freighter. As always, things like this happen when squalls are imminent and we need to get the spinnaker down.

Fortunately, during the past cyclone season I bought and installed a Sitex stand-alone Automatic Identification System (AIS) receiver, which alerts us to the approach of, and identifies, nearby ships. The alarm went off showing that there was a ship 12 miles away, long before we'd have been able to see her with our eyes. Heeding the alarm, we got the spinnaker down and a jib out. By the time we were done, we could see a freighter coming out of the rain at a distance of five miles, heading right for us. Our AIS never showed a name for the ship, but gave a course, 233 degrees, and speed, 15.4 knots. So I hailed the ship on VHF, saying we were the sailing catamaran *Mystic Rhythms* calling the freighter doing 15 knots on a heading of 233 degrees. Someone finally answered on my third try and asked what we wanted.

I told him that he was headed for us — at which point he asked where we were! He requested a bearing, so I gave him the one from us to him. I could hear him talking to someone on the bow using a handheld VHF, telling the guy to look for a boat four points off his starboard bow. I had to call the captain back and give him the bearing from him to us, and tell him to look off his port bow!

Eventually he said that he could see us and would alter course. I asked him what the closest point of approach would be. He didn't understand me, so I asked him how close his radar indicated he would come to us. He said he didn't have that information because he didn't have the radar on! Are we to suppose he has power issues on his ship like we do on a small boat? Somehow I doubt it.

Anyway, he altered course and passed 1.3 miles behind us. If he hadn't altered course, we might have had to take some serious evasive measures. If we'd been singlehanding — as many folks do out here — we may have just gone missing.

I have a triradial radar reflector, and I know that it works because other ships have seen us from as far away as 19 miles. A fat lot of good that does if the crew of the ship isn't using their radar. I guess the best thing a small boat sailor can have

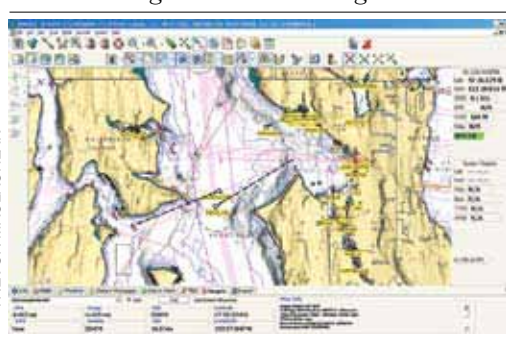

AIS units — an effective and reasonably inexpensive way to see your 'enemies'.

out here is an AIS transmitter as well as a receiver, but they cost too much and draw too much power. An AIS receiver alone is about \$500. They are a bit of a pain to install, because you need a separate VHF antenna, and it must be at least three feet from any transmitting antenna. There goes the top-of-the-mast idea. I had to rail-mount mine, but it still usually works out to about 16 miles in calm seas, or about 12 miles in a little rougher stuff.

My Sitex brand AIS is pretty nice, but needs to have a few major bugs addressed. For example, it has what looks like a mini GPS display that is north up, not your heading up. Unlike most GPS units, the back lighting can't be dimmed, so it's too

TREVOR MACLACHLAN

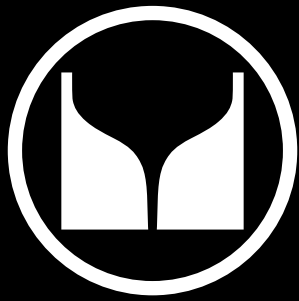

SVENDSEN'S BOAT WORKS

COME TO SVENDSEN'S FOR TRULY SPECTACULAR TOPSIDE AND MAST PAINTING

Our experienced painters do the job right with quality prep work and attention to finish detail. We spray **AWLGRIP LPU** and **AWLCRAFT 2000** (any Pantone color is available).



Call today to schedule your haulout: **510.522.2886**
Or schedule your work online at **svendsens.com**

Located in the Alameda Marina • 1851 Clement Avenue • Alameda, California 94501



passionate about sailing

SAILING VACATIONS



Discover your passion with Sunsail

At Sunsail we share your passion for sailing, and have spent over 30 years working to ensure our charters are the best value available.

No matter if you're a group on our largest yacht, or a couple on our smallest, you'll get the same Sunsail quality and service that make us the best value in sailing vacations today.

Trust your vacation to Sunsail – The company that loves sailing as much as you do...

Call **800 734 8682** or visit www.sunsail.com



Caribbean • Mediterranean • South Pacific
South East Asia • Indian Ocean

LETTERS

bright at night. But the worst bug is that sometimes, after a ship is detected, it just vanishes off the screen — even if it's gotten closer! I hate that bug, but at least the first warning does trip the alarm so you can turn on your radar to start searching if you can't see him with your naked eye. The alarm isn't very loud, however, which means that you can't play your boat stereo very loud. I emailed these suggestions to Sitex, but never got a response. Still, at times this unit is worth its weight in gold to get exact information — name, heading, speed, and distance from you — about ships in your area. And because ours is just a receiver, it uses very little power.

We stand watches 24 hours a day, nonetheless, and this AIS unit does add a bit of extra security out here. If the ship is transmitting its name as well, it makes hailing them very easy, and we almost always get a response. Sometimes all you get is the ship's DSC, a number which would take forever to enter into the VHF to hail them. One thing we've learned is that smaller ships in this part of the world don't have AIS transmitters, so by all means, don't rely on such units completely.

By the way, I have owned three monohulls and three multihulls. To be honest, I can't imagine doing what I'm doing now on a monohull. But it all comes down to what you can afford — and multihulls do cost more — and what sacrifices you are willing to make to get out here.

Richard Clack
Mystic Rhythms, Catana 44
Alameda / Indian Ocean

Richard — A very informative report, thank you. But AIS receivers can be found for much less than \$500. Milltech Marine, for example, advertises that their receivers start at \$189.

↑↓ DAYTRIPPIN' IN MARIN

I'm responding to *Latitude's* response to Pete Malloy of New York, who wondered how sailing would be different if he brought his boat to San Francisco Bay from Long Island Sound. While I agree with *Latitude* that there are a limited number of places for one to enjoy daytrips on the Bay, you forgot to mention that there are several nice places here in Marin for folks



WEBB LOGG

We gotta be honest, we don't think the San Rafael Canal compares to Nantucket as a sailing destination.

with boats to daytrip. For instance, you can sail up to and dock at the Seafood Peddler restaurant in San Rafael, enjoy a lovely lunch or early dinner, and then head back to your home port on the Bay. Or you could continue further up the Bay and dock in downtown Petaluma as well. And let's not forget about beautiful Sausalito and Tiburon. So while it's true that San Francisco Bay isn't dotted with islands like the Eastern seaboard, there are still lovely daytrips to be enjoyed.

Terri Thornton
San Rafael

Terri — At the beginning of each season, we publish a guide to sailing in Northern California, and we usually include the

Remove old flaking paint
Remove weed
Paint bottom, first coat 3 hrs
Paint bottom, second coat 2 hrs

Remove barnacles 8 hrs
Repair gouges 6 hrs
Paint bottom, first coat 4 hrs
Paint bottom, second coat 3 hrs

Sand last years bottom paint
Paint bottom, first coat 4 hrs
Paint bottom, second coat 3 hrs
Chirotractor 2 hrs

Enjoying
boating.

**NOW AVAILABLE
IN SOUTHERN
CALIFORNIA**

Micron[®] Extra is the world's leading copolymer antifouling. It wears away continuously like a bar of soap so you'll always have a fresh layer of biocide to stop fouling. You'll never have to remove flaking paint barnacles, or sand last years bottom paint. And you can haul and re-launch next season without repainting. This means less maintenance...more boating.

So while others spend their time sanding, scraping, and painting, you could be boating.

Visit our website for more information: yachtpaint.com



Outboard Motor Shop

Where the professionals shop!

(formerly Seapower Marine)

BOSTON
WHALER

2007 Model CLEARANCE SALE

More Fun. Less Fuel.



- Quiet, 4-stroke technology
- Unsurpassed fuel economy
- Transistorized pointless ignition
- Ideal for sailboats, small tenders

IDEAL FOR
SAILBOATS
AND
SMALL
TENDERS



POWERED BY

HONDA
MARINE

Meets EPA
2006 & CARB
2008
Emissions
Standards!

© 2007 American Honda Motor Co., Inc.

Always wear a personal flotation device while boating and read your owner's manual.
5-Year Warranty Offer good on all new Honda outboard engines purchased through 3/31/08.
Check with participating dealers for complete details.



BRISTOL FINISH

VARNISH TODAY...

Don't repeat for two to four years!

We use it and swear by it!

NEW

Superlight 2.5 hp 4-stroke

From...



2.5 - 225 hp



2.5 - 350 hp

Clean, efficient
four strokes

Atomic 4 Replacement

Universal
DIESEL MARINE ENGINES



New technology
Fuel efficient
Environmentally friendly



Rugged & Practical
Simple & Sensible

Clearance Sale on
Remaining 2007 C-Dory
INVENTORY - HURRY!



IN
STOCK!

www.outboardmotorshop.com

(510) 533-9290

333 Kennedy St., Oakland, CA 94606 • Fax 510-533-3374

LETTERS

places you mention and many more. And while it's nice to be a 'homer', we've got a greater obligation to the truth. The truth is that while you can have lots of fun sailing to those places on the Bay, comparing them to Long Island Sound, Block Island, Newport, Martha's Vineyard, and Nantucket is about as ridiculous as saying the weather in the Northeast is as good as it is in Northern California.

↑↓ DON'T EXPECT CHANNEL MARKERS ANY TIME SOON

My friend and I have enjoyed many a nice lunch while anchored in Clipper Cove aboard his Sabre 34. But lately, I've noticed that the opening of the cove has seemed to become more silted, so if it's low tide, it can be hard to find a channel deep enough to navigate in. The charts and GPS maps seem to be out of date. Does anyone know of any current and accurate charts, or have helpful hints to prevent running aground?

And, is there any chance that someone might put channel markers in? I suppose that channel markers aren't going to happen because the cove is a jurisdictional 'no-man's land'.

Bob Wills
Santa Rosa

Readers — Sightings Editor LaDonna Bubak reports having good luck hugging the Navy pier when turning into the basin, then heading straight for TISC's docks before veering into the anchorage.

Maybe some of our readers know where the deepest water is going in. Of course, the most fun option would be to go there on a very high tide, take your own soundings, and make your own chart.

The departed Navy is still in charge of Clipper Cove, so don't expect any channel markers soon.

↑↓ WHAT MAKES FOR A CIVILIZED SOCIETY?

In the last issue, "Frustrated Boater" wrote you to criticize the mentality of those who are "squatting" with their boats at Clipper Cove, taking up the prime but limited space from recreational boaters and occasional overnighters. After speaking with some of them, F.B. said — and I'm paraphrasing — that their view was that "all waterways should be free for all" and "we got here first . . . too bad for you." Accordingly, he concluded that one couldn't reason with that type mentality.

Your response was "the problem is not so much the liveboard gang, but crap government," claiming that jurisdictional issues — the Navy having withdrawn — and alleged Coast Guard ambivalence were the culprits.

You've got it wrong! Blaming law enforcement for the public's bad behavior conveniently overlooks the concept of personal responsibility. It's like saying that people who drive irresponsibly or unsafely do so because the CHP doesn't do an effective job of monitoring motorist behavior. No, they are just dangerous, inconsiderate drivers, period.

What makes a civilized society is for individuals to, indeed, satisfy their own needs, but also participate constructively and compassionately as a member of a larger community — in this case, the boating community. "Frustrated Boater" had it right: they are inconsiderate and unreasonable boaters, period.

John Gordon
Los Altos

John — We couldn't agree with you more about the importance of personal responsibility. In our view, the greatest failing of education and U.S. culture since the '60s has been the overwhelming emphasis on personal rights and freedoms, and the



ULLMAN SAILS

The Sailmaker to Champions!

ULLMAN SAILS WEST COAST FALL SALE PROGRAM ENDING OCTOBER 31, 2007

One Design Sails

10% OFF
Single Sail Orders
Additional 5%
on Multiple
Sail Orders

Big Boat Racing Sails

15% OFF
Single Sail Orders
Additional 5%
on Multiple
Sail Orders

Offshore Cruising Sails

20% OFF
All Offshore
Cruising Sails
Turn in your old sail,
receive additional
5% discount!

CONGRATULATIONS TO ALL OUR TRANSPAC 2007 PARTICIPANTS

LOFTS:

Newport Beach
(714) 432-1860
2710 S. Croddy Way
Santa Ana, CA 92704
Dave Ullman
Bruce Cooper
Steve Beck
Erik Shampain

San Diego
(619) 226-1133
2805 Canon
San Diego, CA 92106
Jim Clinton
Tom Niebergall
Chuck Skewes

Long Beach
(562) 598-9441
6400 Marina Drive #9
Long Beach, CA
90803
Bryan Dair
Sam Heck

Marina del Rey /
King Harbor
Mike George
(310) 645-0196
Sam Heck
(310) 418-9179

Ventura
(805) 644-9579
3639 E. Harbor Blvd.
#111
Ventura, CA 93001
Gary Swenson
Deke Klatt

Santa Barbara
Ken Kieding
(805) 965-4538
Gary Swenson
(805) 644-9579

One Design
Charlie Ogletree



Visit our website: www.ullmansails.com

CRUISE CONTROLS MAIN SAIL

Over 4000 In Use
Worldwide



LEISURE FURL[®] IN-BOOM FURLING

- Smooth Operation & Instant Reefing
- Easily Fitted To An Existing Mast
- Integrated Manual Back-up
- Aluminum or Carbon Fiber Construction
- Five Year Limited Warranty

GENOA



John Kretschmer
Professional Passagemaker
Sailing Writer

WHISKER POLES

I count on my Forespar[®] whisker pole. It's an aluminum and carbon, telescoping model that gives me great flexibility when poling out my headsail. It is robust, well engineered and easy to set and adjust.



- Poles Available for Boats 16 to 55 Feet
- Aluminum, Carbon Fiber or 50/50 Construction
- Patented Line Control[™] or TwistLock[™] Adjustment
- Larger Poles Come with Light & Strong Ultra[™] Ends



FORESPAR[®]
MARINE PRODUCTS THAT PERFORM

www.forespar.com

Ph: 949.858.8820
Fax: 949.858.0505

LETTERS

complete absence of any instruction on the critical importance of personal responsibility. A person can be free as a bird and exercise his/her rights to the hilt, and still be a failure as an individual, parent and member of society. But that can't be true of someone who truly takes responsibility for their decisions and actions.

That said, we couldn't disagree with you more about who is to blame for the situation in Clipper Cove. There are a number of places similar to it along the coast of California — La Playa Cove in San Diego, the free anchorage in Newport Beach, Cat Harbor in Catalina, and east of Stearn's Wharf in Santa Barbara

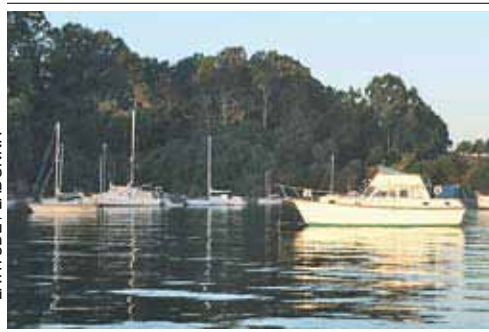

LATITUDE / LADONNA

Has Clipper Cove become the center of maritime personal irresponsibility?

just to name of few. While they are all similar to Clipper Cove and each other, they have very different regulations. At La Playa Cove, it's 72 hours and you have to get a permit first. At the free anchorage in Newport, it's also 72 hours, and while you don't have to get a permit, you're supposed to have someone aboard at all times. At Cat Harbor it's two weeks. Far enough east of Stearns Wharf, you can stay as long as you want. The point is that there is absolutely no consensus about how long a person can 'responsibly' stay in a given anchorage.

Indeed, you and F.B. seem to assume that all responsible mariners have 'normal' lives, meaning they work during the week and get to enjoy their boats on weekends and a couple of weeks straight in the summer. But that's a very restricted vision. What about people who have worked hard all their lives, are retired, and would like to spend a month or two on the hook at a place like Clipper Cove? Or somebody who might want to just sit on the hook for a summer and meditate to the drone of the cars on the bridge above? We don't think either of those would necessarily be unreasonable uses of the anchorage.

In our view, it's the role of government to set regulations for various anchorages, hopefully based on lots of stakeholder feedback, and then enforce those regulations. To have rules without enforcement will not necessarily lead to chaos, but it's a hell of an invitation. By the way, it's estimated that 10,000 automobile deaths a year in the U.S. are a result of the government doing an inadequate job of monitoring bad driving habits. This is based on the fact that speed cameras have reduced highway deaths by 33% in the United Kingdom, 21% in Sweden, 24% in Denmark, 31% in Queensland, and 50% in Victoria, Australia. Since San Francisco has installed cameras at intersections to catch people who run red lights, the number of pedestrian deaths and injuries has dropped by about one-third. On the other hand, after 32 states in the U.S. raised their top speed limit to 75 mph, highway fatalities have risen 38%. Based on those numbers, wouldn't you agree that government indifference to reckless and irresponsible driving has been a major cause of far too many innocent deaths?

The situation in Clipper Cove is convoluted, of course, because all boats that use that cove without the permission of the Navy — and none of them have it — are technically in violation of the law. In our view, this state of limbo, which has been going on for many years, is just another example of, yes,

SEAWIND



In Northern California



YACHT SALES INC.
314 Tideway Dr., Alameda, CA 94501
www.helmsyacht.com
(510) 865-2511

In Southern California
West Coast Multihulls

P.O. Box 6338, San Diego, CA 92166
www.westcoastmultihulls.com
kurt@seawindcats.com
(619) 571-3513



SEAWIND 1160

The new Seawind 1160 is turning heads everywhere. This new 38-ft catamaran has just been launched and is proving to be an immediate success. The 1160 combines some of the best features of the Seawind 1000 and 1200 sailing cats. The winner of 2007 *Cruising World* Boat of the Year, the 1160 features an innovative interior layout for easier living arrangements and stunning sailing performance.



NEW XL!

See the new Seawind 1000 XL debut at Annapolis and Strictly Sail St. Petersburg Boat Shows.



Dan and Carol Seifers have given up their well-loved Gemini catamaran and are picking up their new

Seawind 1160 in Sydney, Australia, this winter. Actually, it will be summer down there. The Seifers plan to visit with the native cultures before setting sail for the South Pacific.



36' CATALINA, 1993

Exceptionally clean, ready to cruise, tall rig. In Southern California. \$84,000. Call Kurt (619) 571-3513.



CORSAIR 24 MKII, 2001

Lightly used, very clean. \$39,900.



41' DEHLER DECK SALOON

Performance cruiser. German engineering built to an exceptionally high standard. This Dehler is in new condition, electric winches, fly-by-wire inside controls. Full weather and sun enclosures. A rare find and a great buy. \$230,000.



HC-50-4

The next step in the evolution of sailing design and technology brings you the most advanced long distance express cruiser. Born of singlehanded around-the-world experiences, the HC-50 is built to provide a fast, stable, and comfortable passage.



THE NEW CORSAIR 750

Arriving this month - call for demo.
Corsair 24s from \$31,000 • F-27s from \$46,500
Corsair 28s from \$72,000



CORSAIR 36

Fast on the water and on the road! \$206,000.

BROKERAGE

Contact Gary Helms at
(510) 865-2511

multihulls
classic sails
one design

offshore spec

NEILPRYDESAILS



San Francisco Bay Area
Jim Leach 415 827-1177
Jack D. Scullion 510 919-0001

Monterey Bay Area
Larsen Sails 800 347-8817

Sail outside the box
www.neilprydesails.com

LETTERS

crap government. The Coast Guard called to say they were going to send us a letter for publication explaining why they supposedly couldn't do anything about the 'squatting' boats in Clipper Cove. Unfortunately, it apparently never got written. That's a shame, for we were eager to learn why they believe they are powerless to cite and/or seize boats that can't pass safety checks and/or aren't registered with either the state or federal government.

Flash! After we went to press, the Coast Guard sent us a letter about the situation at Clipper Cove. Look for it in the November 1 edition of *Latitude*.

↑↓ HOW DO I TIP?

Syren, our J/160, is the 64th boat signed up for this year's Ha-Ha. Can you tell us about Temporary Import Permits (TIP) and if they are required? How can I do the paperwork?

Joseph Christian
Syren, J/160
Newport, Oregon

Joseph — Temporary Import Permits allow you to keep your boat in Mexico for longer than a normal six-month personal tourist visa, legally allowing you to return to the States without your boat. They cost about \$55 and are good for 10 years, so we encourage everyone to get one. While it's sometimes possible to get a TIP online, we think it's more fun and culturally more interesting to get one in Cabo at the end of the Ha-Ha. Too busy to get one in Cabo? No sweat, just pick one up in La Paz, Mazatlan or another port of entry. This is nothing to worry about.

↑↓ IS IT JUST ME?

I'm sure this has been answered in *Latitude* before, but I don't recall seeing it in my 10 years of reading your magazine. According to Rains' *Mexico Boating Guide*, if you don't want to clear into Mexico until Cabo San Lucas, you cannot stop at Puerto San Carlos in Mag Bay. And if you are boarded or have trouble down the Baja coast and haven't cleared in, you are technically in violation of the law. So are we talking speeding ticket-type violation here, or a few days in the slammer? As one of the approximately 200 boats planning on going straight from San Diego to Cabo, am I the only one concerned about this?

M. Jones

M. — Yes, you are the only one concerned about it. You need to clear into Mexico at your first port of entry, be it Ensenada, Cedros Island, San Carlos in Mag Bay, Cabo San Lucas, Mazatlan, Puerto Vallarta or any of the others. So if you stop at San Carlos, which is a port of entry in Mexico, on the way to Cabo San Lucas, you indeed have to clear in. But what would be the problem with that? As for going straight from San Diego to Cabo, what do you think all the participants in the various Mexican races do, stop at some port of entry along the way, sprint around to all the government offices to clear in, then rush back to their boats to reset their chutes?

What happens if you stop somewhere along the Baja coast that isn't a port of entry — such as Turtle Bay or Bahia Santa Maria — before clearing into Mexico? Nothing. We base this on the fact that we've done that for 14 out of the last 15 years with our own boats, and in over 30 years of covering cruising in Mexico, we have never heard of anyone who did it having a problem.

Anchoring along the coast of Baja before you've cleared into the country may or may not be a technical violation, but if it



WOW!

There is a new way to enjoy a Beneteau

HOW?

You can do it with Beneteau Fractional Yachting

NOW.

Visit beneteaufractional.com or contact your local dealer



BENETEAU

**FRACTIONAL
YACHTING**

We Still Offer More!



Making boating easier – and more fun! is what a marina should be all about.

That's why Oyster Cove Marina rates number one with many Bay Area boaters. It's an exclusive yet reasonable facility of 219 berths, accommodating pleasurecraft in slips up to 60-ft long.

Oyster Cove is the Peninsula marina closest to Blue Water boating.

Want to cruise to Sausalito, lunch at Tiburon, or sail to Angel Island? How about a day's fishing outside the Gate, or a weekend at the Delta? No other private Peninsula marina is better situated or offers nicer, fresher surroundings.

- Berths 30 feet to 60 feet
- Double Finger Concrete Slips
- Telephone Available
- Five Minutes from SFO
- Heated Dressing Rooms & Showers
- Laundry Room
- Nightly Security Patrol
- Complimentary Ice
- Cable TV/High Speed Internet
- Recently Dredged
- End Ties Available at \$5.75/Ft!



OYSTER COVE MARINA

385 OYSTER POINT BOULEVARD #8A
SOUTH SAN FRANCISCO

(650) 952-5540

LETTERS

is, it would be right up there with ripping that 'Do Not Remove' sticker off your mattress. "Tickets? Days in the slammer?" If you haven't been to Mexico by boat before there is no way for you to know, but you're being way too paranoid. Mexico loves maritime tourists because they are by nature friendly and because we bring so much money into their economy. As such, as long as you don't behave like an ass, expect officials to treat you as a welcome guest, not a potential target.

↑↓ A SHIP STATION LICENSE IS REQUIRED

There was an article in the July/August issue of Canada's *Pacific Yachting* magazine that said all U.S. boats that use a VHF radio in Canadian waters have to have a Ship Station License. It said such licenses were good for 10 years, and cost \$160. Is this true? Would the licensing requirement also apply to U.S. boats traveling to Mexico?

Alan Hughes

Hopefully a Lagoon or Leopard
Vancouver, WA

Alan — All U.S. flagged vessels with SSB radios aboard, as well as all U.S. flagged vessels with any transmitting equipment aboard while in foreign waters, must have a Ship Station License. And yes, it costs \$160 and is good for 10 years — or until you sell your boat. The license is non-transferable.

But wait, like they say on TV, there's more! Mariners operating marine SSB radios in foreign waters must also have a Restricted Radio Operator's License. This no-exam license covers the individual for any marine radio installation. It costs another \$65, but at least is good for a lifetime.

We know all this stuff because we had an inkling that our old Ship Station License had expired about 10 years ago, and thought it would be nice to be legal in time for late October's Ha-Ha XIV. A Ship Station License will consist of three letters and four numbers that become your call sign. Our new one is WDD9575 — pretty snappy, don't you think? If you're going to have SailMail on your boat, your call sign will become your SailMail address, too.

We had Gordon West's Radio School process all the licensing for us because it can be a pain and some of it can get a little tricky. They also make sure that your EPIRB is registered and that you get your nine-digit MMSI number for your DSC-capable VHF and SSB radios. The Radio School charges fees for both licenses, and while we're normally pretty flinty, we thought it well worth the expense to get it done right and in just a day or so. Contact the school at 714-549-5000 for details about what's needed and the costs. This is Whiskey Delta Delta Nine Five Seven Five — clear!

↑↓ IF ANYONE WANTS AN OLD BIKE, IT'S STILL THERE

We got a kick from reading in *Lectronic* about the problems *Profligate's* crew had when trying to weigh anchor — as well as two other anchors, a cinder block, two types of chain and three types of line — at Cat Harbor, Catalina. It reminded us of a similar problem.

In July of '05, we were anchored at Long Harbor on Ganges Island, British Columbia, having spent a great Canada Day with friends at the Royal Vancouver YC. We timed our departure the next day to hit slack water at Active Pass so we could continue on to Howe Sound. If you haven't cruised in the Pacific Northwest, you may not realize how critical it is to transit these passes at the right time. If you don't, it can be hair-raising.

So at 8 a.m. we weighed anchor — or at least tried to. What chain we could bring up was very muddy, so Mary worked

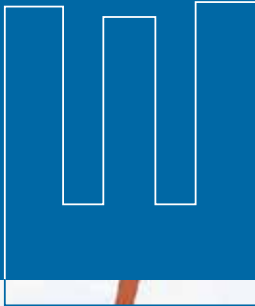

Doyle APC



- :: Doyle's Asymmetrical Power Cruiser fills the gap in your downwind inventory
- :: Easy to set and douse with a spinnaker sleeve
- :: Reaches faster than a genoa, runs like a spinnaker—without a pole or hardware
- :: Stable and easy to trim
- :: Your choice of colors

www.doylesails.com



DOYLE SAILS ▶ 2035 Clement Ave ▶ Alameda, CA 94501 ▶ 510-523-9411
San Francisco

THE SAILMAKERS WHO MAKE IT POSSIBLE.

WHALE POINT



MARINE & HARDWARE CO.

**A FAMILY OWNED & OPERATED BUSINESS
FOR THREE GENERATIONS**



MARINE PARTS & ACCESSORIES, PLUS A COMPLETE HARDWARE STORE

"DISCOUNT PRICES WITHOUT THE ATTITUDE!"

POWER INVERTER BY BLACK & DECKER



Covers power from 12V to 110V
100W **\$21.99** • 200W **\$25.99**
400W **\$39.99** • 750W **\$79.99**

FORCE 10 Water Heater

120V with heat exchanger.



FORCE 10

SS 6 gal • #406011 • **NOW \$229⁹⁹**
SS 11 gal • #411011 • **NOW \$269⁹⁹**
SS 20 gal • #418001 • **NOW \$379⁹⁹**
Galvanized 6 gal • **NOW \$219⁹⁹**

AIR DRYR 1000



Handles up to 1000 cu. ft.
Safe for marine use.
Now \$54⁹⁹

PORTABLE HEATER

Indoor safe propane heater.



Mr Heater
4,000-9,000 BTU: **NOW \$99⁹⁹**

SUCTION CUP 4" POWER GRIP

Strong suction cup holds to any smooth surface, like a fiberglass hull.



NOW \$4⁹⁹

TAYLOR FENDERS



Model..... Size West... **Whale Pt.**
1022..... 5.5x20" ...\$16.49..... **\$12.99**
1023..... 6.5x23" ...\$25.29..... **\$19.99**
1028..... 8.5x27" ...\$43.99..... **\$33.99**
1024..... 10.5x30" ...\$49.99..... **\$39.99**

STEARNS Cold Weather Gloves



NOW \$19⁹⁵

SILVER MARINE Inflatables



Length..Width.....Max Floor **NOW**
7'8" ... 4'1" .. 2.7hp .. Roll-up **\$699**
8'2" ... 4'3" 4hp .. Roll-up **\$799**
9'8" 5' .. 9.9hp ... Wood ... **\$1199**

205 Cutting Blvd, Corner of 2nd, Richmond
510-233-1988 • FAX 233-1989
Mon-Sat: 8:30am - 5pm • Sun: 10am - 4pm
Email: whalepoint@acehardware.com

LETTERS

the windlass while I went at the chain with a special brush we'd made. It's actually three scrub brushes mounted on a triangular holder that fits on the end of a boat pole. When I work the device up and down the chain at water level, it really scrubs the mud off.

But halfway up, we found a rusty, shellfish-encrusted bicycle — complete with basket — entangled in our chain. How, we wondered, were we going to get the bike off? If the dinghy



BILL FINKELSTEIN

If Bill hadn't been in such a hurry, a little elbow grease and his three-brush scrubber would have had this bike looking like new.

was still in the water, it would have been easy, but we'd already stowed it. And if we brought the bike up on our chain, we'd scratch the hull of our lovely boat.

First we tried to dislodge the bike with our boat hook, but the bike was so heavy that it kinked the pole's tubing! Then we pulled the bike just close enough so that, if I got down on my stomach, I could just reach it. Our chain was wrapped pretty tightly around one of the bike pedals, but after 15 minutes of huffing and puffing, we finally got the bike off the chain. After that, the anchor came right up.

If anyone wants an old bike, it's probably still there. Anyway, we still made it to Active Pass before things got too gnarly.

Bill Finkelstein & Mary Mack
Raptor Dance, Valiant 50
Paradise Village Marina, Nuevo Vallarta

↑↓ THINGS AREN'T ALWAYS EASIER TO LIFT IN WATER

We had our anchor raising problem just outside the entrance to San Francisco's South Beach Harbor. At the time, we were doing anchoring practice for our American Sailing Association BBC certification under the tutelage of Leslie Waters of Spinnaker Sailing.

When it came time to raise the anchor, there was a tremendous strain on the line, and initially we thought the flukes of the Danforth were just dug really deeply in the mud. We tried motoring over the hook to break it free, but that didn't work. Then, while hauling in the rode, we noticed that we were drifting downwind! How could it be that we couldn't get the hook up but were still able to use our engine to motor clear of other boat traffic?

By this time we were tired, wet, and frustrated. We started throwing rolling hitches on the rode, then tried to winch the anchor up using the primaries. When the chain finally appeared, there was another mystery — it was covered in mud. As we brought more up, the decks were not a pretty site. After an hour, the situation was bleak. The three of us were soaked in perspiration and covered in mud, the decks were wasted — and we still didn't have the hook up!

When the anchor finally broke the surface, we immediately saw the problem — it had snagged an old two-inch diameter steel cable. Ugh! No wonder we couldn't get it up, but could still move around — the anchor was sliding along the cable! Judging from the angles, the piece of cable was at least 100 yards in length. Whoever said things are easier to lift in water

COME VISIT COYOTE POINT MARINA:

The Peninsula's Complete Recreational Destination!



**RECENT
DREDGE
COMPLETE!!**



BERTHING

- Slips to 40' available
- 22' inside ties for \$85 per mo.
- Multihull side ties available
- Check out our rates!

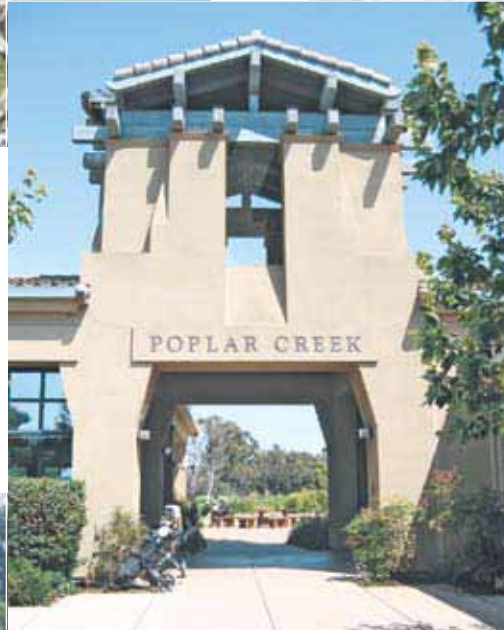

FUEL DOCK & PUMP OUT

- Open 7 days per week
- Gas and diesel available
- Check our prices
- Free pump outs



**GREAT
WEATHER!**



COYOTE POINT RECREATIONAL AREA – HOME TO:

- Coyote Point Marina
- Poplar Creek Golf Course
- Coyote Point Park
- Captain's House Conference Center
- Beach, Picnic & BBQ Areas
- Coyote Point Yacht Club
- Dominic's Restaurant
- Magic Mountain Playground
- Coyote Point Museum
- Shoreline Trail

COME FOR A VISIT – WE THINK YOU'LL STAY

Call us and mention this ad for a FREE One Night Guest Berth

COYOTE POINT MARINA ~ 1900 Coyote Point Drive • San Mateo

650.573.2594



YEAR-END CLOSEOUT!!! FACTORY DIRECT!!!

SAVE THE DATES:
December 3 thru December 8
9:00am - 3:00pm

Precision Lighting Showroom
3635 Standish Avenue, Santa Rosa
Just two blocks off Hwy. 101 – Todd Rd. Exit

- Hundreds of overstock items
- Hundreds of factory seconds
- Hundreds of discontinued stock
- Holiday gift items: Desktop/bar globes, knives, porthole clocks, barometers, mirrors, ship bells
- 12-volt light fixtures
- Cabinet hardware, plumbing hardware, restoration hardware

WWW.ABIMARINE.COM
800•422•1301
707•585•6210

LETTERS

wasn't aboard with us that evening.

John Ryan
Pursuit, Beneteau 310
Berkeley

↑↓SAND AND OUTBOARDS MAKE FOR POOR HOLDING

Speaking of pulling stuff up from the bottom with one's



DOUG GOULD

The new Evinrude-style anchor proved unreliable at Block Island.

anchor, last summer I noticed a Hans Christian dragging anchor in Great Salt Pond at Block Island, Rhode Island. Nobody was aboard, but I was able to get to her before she went aground. Imagine my surprise when I got the hook to the surface and noticed it had

been fouled on an outboard motor! I managed to snap this photo just before the Evinrude fell off.

Doug Gould
Water Torture, Marine Trader trawler
Block Island, Rhode Island

↑↓MEXICO AIN'T NOTHIN' COMPARED TO RHODES

In the early '80s, I was the engineer aboard a classic 110-ft 1930s motoryacht. We were running charters along the coast of Turkey but, because of the laws back then, had to pick up and drop off our 'guests' in Rhodes, Greece, which is just a stone's throw from Turkey.

If you've ever visited the old harbor at Rhodes, you will know how tight things get, and that the bigger motoryachts drop an anchor, then back in to stern-tie to the quay. There is a protocol — first in, last out — amongst captains that enables everyone to squeeze in for the night. The smaller sailboats do the same, but across the narrow harbor on the other side of the seawall.

We were the first to leave at daybreak and, as engineer, my job was to stand by in the engine room until we got full



Colossus became concerned, with good reason, with the advent of the new tall rigged ships.

ahead. Then, while the bow anchor was being hauled in, I was to assist the bosun on the back deck coiling docklines and taking in the fenders. As I came up on deck that morning, I couldn't help but notice that we had a vessel 'in tow'. She was similar to a Catalina 27 and flying a German flag. As we towed the boat backwards, a nude and irate German national came out of the companionway and began shouting obscenities at us. And why not, as we were pulling his small boat back-

wards out of the harbor entrance at 10 knots.

With our stern wake about to break over the little boat's transom, I ran up to the bridge to inform the captain that we had a German following us. "Don't worry," the captain replied,

Yacht at Rest, Mind at Ease

- Safest Way to Ship
- Premier Service for Any Yacht
- Reliable Frequent Schedules
- Unique Destinations
- Competitive Rates



Sailing Schedule 2007

VOYAGES FROM THE MEDITERRANEAN

MEDITERRANEAN TO EAST COAST USA

Genoa	09/07	→	Port Everglades	09/07
Genoa	09/07	→	Port Everglades	10/07
Genoa	10/07	→	Port Everglades	11/07
Genoa	12/07	→	Port Everglades	12/07
Palma de Mallorca	10/07	→	Newport	11/07
Palma de Mallorca	09/07	→	Port Everglades	09/07
Palma de Mallorca	10/07	→	Port Everglades	10/07

MEDITERRANEAN TO CARIBBEAN

Genoa	12/07	→	Martinique	12/07
Palma de Mallorca	11/07	→	Martinique	12/07
Toulon	10/07	→	Martinique	10/07

MEDITERRANEAN TO SOUTH PACIFIC

Genoa	12/07	→	Auckland	02/08
Genoa	12/07	→	Brisbane	01/08

VOYAGES FROM NORTHERN EUROPE

NORTHERN EUROPE TO CARIBBEAN

La Rochelle	12/07	→	Martinique	01/08
-------------	-------	---	------------	-------

VOYAGES FROM THE EAST COAST USA

EAST COAST USA TO MEDITERRANEAN

Port Everglades	10/07	→	Genoa	10/07
Port Everglades	11/07	→	Genoa	11/07
Port Everglades	09/07	→	Palma de Mallorca	10/07
Port Everglades	09/07	→	Toulon	10/07

EAST COAST USA TO CARIBBEAN

Newport	11/07	→	Freeport	11/07
Newport	11/07	→	St. Thomas	11/07
Port Everglades	10/07	→	St. Thomas	10/07
Port Everglades	11/07	→	St. Thomas	11/07

EAST COAST USA TO PACIFIC WEST COAST

Newport	11/07	→	Ensenada	12/07
Newport	11/07	→	Golfito	11/07
Newport	11/07	→	La Paz	12/07
Newport	11/07	→	Vancouver	12/07
Port Everglades	11/07	→	Ensenada	12/07
Port Everglades	11/07	→	Golfito	11/07
Port Everglades	11/07	→	La Paz	12/07
Port Everglades	11/07	→	Vancouver	12/07

VOYAGES FROM THE CARIBBEAN

CARIBBEAN TO EAST COAST USA

Martinique	12/07	→	Port Everglades	12/07
St. Thomas	10/07	→	Newport	10/07
St. Thomas	11/07	→	Port Everglades	11/07
St. Thomas	11/07	→	Port Everglades	11/07

CARIBBEAN TO MEDITERRANEAN

Martinique	11/07	→	Palma de Mallorca	11/07
------------	-------	---	-------------------	-------

CARIBBEAN TO NORTHERN EUROPE

Martinique	12/07	→	La Rochelle	12/07
------------	-------	---	-------------	-------

CARIBBEAN TO PACIFIC WEST COAST

St. Thomas	11/07	→	Ensenada	12/07
St. Thomas	11/07	→	Golfito	11/07
St. Thomas	11/07	→	La Paz	12/07
St. Thomas	11/07	→	Vancouver	12/07

CARIBBEAN TO SOUTH PACIFIC

Martinique	12/07	→	Auckland	02/08
Martinique	12/07	→	Brisbane	01/08

VOYAGES FROM PACIFIC WEST COAST

PACIFIC WEST COAST

Ensenada	12/07	→	Vancouver	12/07
Golfito	12/07	→	Ensenada	12/07
Golfito	12/07	→	La Paz	12/07
Golfito	12/07	→	Vancouver	12/07
La Paz	09/07	→	Golfito	10/07
La Paz	12/07	→	Vancouver	12/07
Vancouver	09/07	→	Golfito	10/07
Vancouver	09/07	→	La Paz	09/07
Vancouver	12/07	→	La Paz	01/08

PACIFIC WEST COAST TO EAST COAST USA

Golfito	10/07	→	Port Everglades	10/07
La Paz	09/07	→	Newport	10/07
La Paz	09/07	→	Port Everglades	10/07
Vancouver	09/07	→	Newport	10/07
Vancouver	09/07	→	Port Everglades	10/07
Vancouver	12/07	→	Port Everglades	01/08

PACIFIC WEST COAST TO CARIBBEAN

La Paz	09/07	→	St. Thomas	10/07
Vancouver	09/07	→	St. Thomas	10/07

Dockwise Yacht Transport USA
Telephone +1 954 525 8707
E-mail: dwt.usa@dockwise-yt.com

Dockwise Yacht Transport Europe Srl
Telephone +39 [0]10 278 9411
E-mail: dwt.europe@dockwise-yt.com

Dockwise Yacht Transport France
Telephone +33 [0]493 931 856
E-mail: dwt.france@dockwise-yt.com



WORLD CLASS YACHT LOGISTICS

www.yacht-transport.com

All dates are approximate dates without guarantee. More information on sailing schedules visit:

**IF YOU WANT YOUR
BOAT TO BE A
BOAT-OF-THE-YEAR,
THE ODDS ARE BETTER
WHEN YOU
HAVE UK-HALSEY
IN YOUR CORNER.**



Cruising World's 'Import Boat of the Year' and 'Best Mid-Size Cruiser' is the Malö 40 (www.maloyachts.se), judged with her UK-Halsey sailplan to be "a sweet-sailing boat." *Sailing World* picked the Salona 37 with her UK-Halsey sailplan as 'Cruiser/Racer Boat of the Year'. What they share in common could make whatever you're cruising a better sailing experience.

Flat-out cruiser.
Or cruiser/racer.
Great sails just make
yours better.



NORTHERN CALIFORNIA

451 W. Atlantic, Suite 115, Alameda, CA 94501
(510) 523-3966

Sylvain Barrielle · Synthia Petroka · Jason Crowson · John Herne

www.ukhalsey.com • sanfrancisco@ukhalsey.com

LETTERS

"we won the war!" Fortunately, nobody was hurt.

What had happened is that the German sailor had come in late at night, tied to the seawall, then dropped his anchor on top of ours. When we left, the poor guy was asleep, only to be awoken at the sound of us pulling the bow cleats off his boat.

Mike Wilson
Mexicolder
Mazatlan

Mike — We visited Rhodes Harbor with Big O back in the mid-'90s — long after the famous Colossus that supposedly spanned the entrance was gone — and yes, we know exactly how tight things can get there. Even when it seemed like there wasn't even room for another small boat, some guy with an 80-ft motorsailer would drop his hook, put his boat in reverse, and back toward your bow at ramming speed, gesturing wildly and hollering stuff in some foreign language. It was very exciting. You either made room for him or resigned yourself to an extensive bow repair. Once that guy made it in, about three more even larger boats would do the exact same thing. Sailors in California and Mexico have no idea how tame and civilized things are here compared to the Med.

↑↓ I GOT DUMPED OVER A NON-OWNER PARTNER

I'm in a quandary. BoatUS has said they are going to cancel our boat insurance policy just because I inquired about having another non-owner partner listed on the insurance policy. It's clear to me that many boatowners have partners who pay a certain amount of money — often just enough to help cover monthly expenses. In fact, many of them advertise in *Latitude*. Yet it seems as if it's almost impossible to get insurance coverage. The brokers and other firms we've contacted act as though we're criminals when we ask them about it. And BoatUS certainly treated us unfairly — a matter I plan to take up with the California Department of Insurance.

Meanwhile, I'm wondering if you have any advice for me, as I'm perplexed as to what others do. Surely other boatowners in these arrangements don't expose themselves to the legal risks associated with having uninsured partners. But like I say, the insurance companies are treating us like we have the pox, saying that we're running a commercial operation. But as a licensed sailing instructor for one of the major sailing schools in the Bay Area, I clearly know the difference between having a casual partner and running a presumably for-profit business.

Paul Jones
Om, Catalina 320
South Beach Harbor

Paul — We hate to not necessarily agree with you, but when you say that you clearly know the difference between having a "casual partner" and "running a business," we're not sure that there is one. That's particularly true when you refer to "another non-owner partner." How many do you have and/or do you want? When you talk of more than one, it certainly begins to walk and talk like a business, albeit a small one.

Further, your concept of a "non-owner partner" seems a bit like an oxymoron. Sort of like an 'unmarried spouse'. By definition you can't be a partner in something you don't own a part of.

We presume that there are indeed boatowners around the Bay who have people — usually trusted long-time friends — who contribute money to help offset boat expenses in exchange for use of their boat. There probably wouldn't be any

ANDERSON'S BOAT YARD

The #1 Boat Yard on the Bay!



Anderson's would like to welcome new customer Joe Nazar.

When Capt. Joe needed to overhaul his 65-foot *Kitty Kat*, there was no question where he would turn. "Anderson's is simply the best boatyard on the Bay. There's nothing they can't do." Coming soon to the *Kitty Kat*: special wheelchair access that Anderson's will be custom building.

Learn more about the *Kitty Kat*'s eco-friendly whale-watching at:
www.sfbaywhalewatching.com

*All of us at Anderson's
would like to thank
all our customers
for choosing the
#1 boatyard
on the Bay.*

Call Now to Reserve Space for:

- Sprayed Racing Bottoms
- Custom Topside Paint Jobs
- Complete Rigging & Wood Shops
- Custom Metal Fabrication
- Electrical Installation & Repairs
- Engine Service and Repower

*Come see us
for your
boating needs!*

400 HARBOR DRIVE • SAUSALITO, CA 94965

(415) 332-5432 • (800) 310-5432

Fax: (415) 332-8136

andersonsboat@pacbell.net • www.andersonsboatyard.net

yachtpaint.com

The Sun Always Shines at Cass' Marina



Our Instructors: David, Barbara, Glen & Kal

SAILING SEASON DOESN'T HAVE TO END!

Weather permitting, we're open year round.

SAILBOAT RENTALS at affordable prices.

CHARTERS – for up to 6 people with a US Coast Guard licensed skipper. See Angel Island, the San Francisco city front and of course the Golden Gate Bridge from a new perspective. Our charters are a great way to explore the Bay like you've never done before.

Take advantage of our **LEARN TO SAIL PACKAGES** and learn to sail, the US Sailing Certified way!

INTERNATIONAL SAILING ADVENTURES – Greece, Croatia, Thailand and the Andaman Sea!

CASS' MARINA

SAILING SCHOOL & CHARTERS

*46 Years of Service to Sailors
on the San Francisco Bay*



(415) 332-6789

www.cassmarina.com

1702 Bridgeway at Napa in Sausalito

LETTERS

problem as long as: 1) No claims are made, or 2) If a claim had to be made, everybody involved stayed absolutely mum about money having changed hands on a regular basis. After all, at least some policies allow for people other than the owner to use the boat without the owner onboard. But if there ever was a claim, and the insurance company found out that a significant amount of money had been paid on a regular basis in return for the use of the boat, there could be big problems. Indeed, if the claim involved a serious injury or even death, it could be financially catastrophic.

As we understand the Coast Guard regulations, people are allowed to contribute money toward the expenses of a sailing adventure and not be "paying passengers" as long as the money contributed isn't in excess of the boat expenses. (The concept of boat expenses isn't explained, so it's unclear if they are limited only to expenses specific to that one adventure or if it could also include prorated amounts of annual expenses of such things as boat payments, slip fees, insurance, the annual haul out and so forth.) But just because the Coast Guard might view it that way doesn't necessarily mean that your insurance company — and for that matter, the IRS — would do the same.

We don't claim to have any expertise in this area other than to know that it could be very tricky and sticky, so we urge you not to proceed without expert legal advice. As for going to the California Department of Insurance, if you already have one 'non-owner partner', we don't think they are going to look positively on your complaint.

↕ **PARTNERSHIP PAPERWORK**

I'm trying to find the paperwork necessary to form a partnership on a boat and mooring, as well as whatever other documentation I might need to take care of. Where can I get such forms? I'm in the process of buying out my partner in a Newport 28, and would like to protect myself. Currently, my partner and I only have a verbal agreement.

Thomas R. Hill
Central California

Thomas — It's a little confusing, as you seem to be saying that you're trying to form a partnership at the same time you're trying to buy out a partner. If you're buying out a partner, the important things to do are get a bill of sale signed by both of you and witnessed, have him/her sign off on the pink slip for the boat, then get the boat registered in your name with the DMV. It's just like a car for state registered boats. If you're taking on a new partner, you'll want to write up a partnership agreement, then register the boat with the DMV, either in both your names or in the name of the partnership.

Buying a mooring would be a completely separate transaction, so you'd need a different bill of sale from whomever or whatever entity owns the mooring and/or the land that it's on. Make sure it's a legal mooring, however, or you may be paying for something that is potentially worth nada.

We're not aware of any forms specific to boat partnerships, but you can find the basic elements of any partnership agreement on the Internet. When it comes to boat partnerships, you — and your partner — are best served by a written rather than verbal agreement.

↕ **LIGHT YOUR BOAT UP LIKE A CHRISTMAS TREE**

Our cruising story began in Colorado three years ago, and I think a short recap would be illuminating for other new or soon-to-be cruisers. The impetus was when my future husband's mom gave him a gift of sailing lessons on Lake Dillon at Breckenridge. My future husband was immediately

There's Always a Boat Show at Marina Village

NOW MORE THAN EVER!*

**Sellers/Buyers
OPEN BOAT
WEEKEND**

**OCTOBER
13 & 14**



J/100



C&C 99



Catalina 350



Beneteau First 10R



J/124



C&C 115



Catalina 36 MkII



Island Packet 445



Sabre Spirit



Tartan 4100



Catalina 470



Wauquiez 41 Pilot Saloon

*J-Boats/Sabre
Sail California
(510) 523-6730*

*Tartan/C&C Yachts
of San Francisco
(510) 769-9400*

*Catalina
Farallone Yachts
(510) 523-6730*

*Beneteau/ Island Packet/
Wauquiez/Alerion
Passage Yachts
(510) 864-3000*

Call A Marina Village Broker to List Your Boat Today!

MARINA VILLAGE YACHT HARBOR

Much More than Just a Marina

(510) 521-0905 • www.marinavillageharbor.com

Want to start sailing right? Upgrade your skills? Call J/World (510) 522-0547





**West Marine®
Rigging Service**

Custom RIGGING by the Experts!

From outfitting traditional cruisers to fine-tuning cutting-edge racers, let West Marine's experienced staff design the ultimate package to optimize the performance and look of your boat. Custom rigging is available through any West Marine store location.

POWERLITE
PRO RIGGING



NEW ENGLAND ROPES

SAMSON

HARKEN®

Marlow®

**SCHAEFER
MARINE**

RONSTAN

Hayn Marine

LEWMAR®

FORESPAR®

- **PowerLite PBO**
- **Running Rigging**
- **Standing Rigging**
- **Dock & Anchor Lines**
- **Lifelines**

Contact us at 888-447-RIGG, or visit our
Onsite Rigging Locations in:

Alameda

730 Buena Vista Av.
Ph 510-521-4865

San Diego

1250 Rosecrans St.
Ph 619-255-8844

Seattle

1000 Mercer St.
Ph 206-292-8663

LETTERS

hooked, as it gave him something new to master. All he needed then was a girl and a scheme to combine his love of travel and his new interest in sailing. Little did we know that it would eventually lead to us getting involved in a potentially very sticky on-the-water personal injury situation with authorities in Mexico.

Before I get ahead of myself, the summer after the sailing lessons, Matt and I began to dream about being married, buying a boat, and sailing off into the sunset. There were obstacles, of course. First, we'd only sailed on a lake in Colorado, which



COURTESY SONADORA

Matt and April in Mexico, a long way from Lake Dillon, Colorado.

isn't really an adequate primer for sailing on the open ocean. Secondly, we needed money. That second problem was easy to solve. In addition to our 40-hour-a-week jobs, Matt as a mechanical engineer and myself as a veterinarian's assistant, we took

on second jobs. Matt tended bar and I did janitorial work. Did I mention that we were very motivated to quit our jobs, sell our stuff, and just go for it?

We got married, picked up our new-to-us Catalina 36 Soñadora in San Diego, and began acquiring ocean sailing experience. Our first trip was a short one, to Mission Bay, but we still got sick. But we kept learning with every 'baby step' up the coast. That was all fine and good, but we needed a guideline for our next phase — a cruise south to Mexico. We found it by signing up for the '06 Ha-Ha. Since that event wouldn't start for six months, we found an expensive slip in Dana Point — nothing was available in San Diego — and worked on building up our cruising kitty. We also worked to further develop our cruising skills, sailing to Catalina a number of times, circumnavigating it once, and doing a cruise up to the Channel Islands.

Although we didn't have a ton of offshore experience, we were ready to sail to Cabo on our own, so that qualified us for the Ha-Ha. Going on the Ha-Ha was important, too, because we just had to get a couple of those neon Ha-Ha shirts. The six months passed quickly as we worked, purchased and installed some essential gear, and even trained our two dachshunds to do their 'business' on deck.

Thanks to the *Latitude* Crew List, we found a couple of crew to help us do the Ha-Ha. Thank goodness for them, especially for the woman, whom we nicknamed The Iron Chef. At one point we were all seasick — except for her. She loved to be down below cooking or cleaning in the galley. In fact, by the time the Ha-Ha was over, she had our galley cleaner than when we started.

The Ha-Ha was just the challenge we needed for our first cruising season. One of the best things is that it gave us a deadline to be ready by. The other thing I liked best about it were the social activities during the R&R stops. We met so many terrific people, and because we were sharing a common adventure, it felt as though we'd known them for a long time.

We had some doggie excitement, too. During the start off

THE FINEST SAILS BEGIN WITH THE BEST SAILCLOTH

Our patented woven Vectran® sailcloth performs like the laminates with the durability of Dacron®, especially in roller furling applications. In fact, Vectran® is lighter, lower stretch, and retains its shape over a longer life than any sailcloth we've ever offered to cruising sailors. That's because Hood Vectran® is woven, not laminated to Mylar® film. And you can be sure that each sail we roll out is built by hand, with the same care and craftsmanship that has been the Hood hallmark for 50 years. To discuss your sailcloth needs – whether our state-of-the-art Vectran® or our soft, tight-weave Dacron® – give us a call today.



SAILMAKERS

Call Robin Sodaro
(800) 883-7245
(415) 332-4104
Fax (415) 332-0943
email: hoodsails@aol.com

-  Sails & Service
-  New Sails
-  Sail Repairs
-  Furling Conversions
-  Pickup & Delivery
-  Fall Discounts
Now in Effect

*Jim Fair's
Outbound 46,
'Chesapeake'
Photo Courtesy
of Swiftsure Yachts*

Visit our website for Special Online Discount Pricing...
www.hoodsailmakers.com

HOOD SAILMAKERS
466 Coloma Street, Sausalito, CA 94965

LOCATION!
LOCATION!
LOCATION!

DON'T WASTE THAT DAYLIGHT!

**RENT YOUR VERY OWN SLIP –
60 SECONDS FROM THE BEST
SAILING ON THE WEST COAST!**

- EASY ACCESS FROM DOWNTOWN
- CONVENIENT DISCOUNTED PARKING
- 24-HOUR ON-SITE SECURITY
- FULL SERVICE FACILITIES

VISIT OUR NEW WEBSITE
FOR DETAILS
WWW.PIER39MARINA.COM



PHOTO COURTESY CHARLIE BERGSTEDT

PIER 39
MARINA

NOW AVAILABLE
SLIPS FROM 36' TO 60',
90'x48' SLIP & 80' SIDE-TIE
(415) 705-5558

LETTERS

Bahia Santa Maria, the stainless steel O-ring on Coner's doggie lifejacket broke, disconnecting him from the tether that kept him on the boat. So it was 'Dachshund Overboard!' Matt was able to snag Coner's lifejacket handle with the boat hook and pull him back aboard.

The 10 days of the Ha-Ha passed in what seemed like a blur. All of a sudden we found just the two of us on our boat



COURTESY SONADORA

Matt and April didn't plan on having to replace their bow pulpit, but it was just part of the adventure.

in Cabo and not exactly sure what to do next. So, like a lot of other folks, we decided to continue on up to La Paz. While there, we attended an intensive — four hours a day, five days a week — Spanish language school. *Mucho trabajo!* We recommend a program like this to all cruisers traveling to Mexico, as knowing the basics of Spanish opens up many special and colorful opportunities. We were surprised to meet folks who had been cruising in Mexico for more than a year and still didn't know anything more than, "Una mas cerveza, por favor."

We loved the culture of La Paz and her passionate people. But the residents of the 'City of Peace' sure get a kick out of honking their horns at all hours of the night! We even experienced our first Norther — three days of 35 knots — while on the hook at La Paz. Our boat pitched and bobbed up and down as though we were sailing in rough weather, but we were still anchored to the bottom.

After being in La Paz awhile, we were sort of surprised to hear that it can often be chillier than chilly in the Sea from November through April, and that the water is too cold for swimming. I may not have mentioned that we Coloradans didn't even buy foul weather gear until we'd been sailing — and often freezing — in the waters off San Diego for several weeks. Silly? Sure, but we'd been brainwashed by all the PR that says it's always sunny and warm in Southern California. That's not true, at least not along the coast. Anyway, some cruisers in La Paz explained that the smart thing to do is sail over to the warm mainland for the heart of the winter, then return to the Sea in the spring when it's warmed up again.

So with Christmas approaching and our parents slated to be in Mazatlan, it was time to cross the Sea to the mainland. We decided to buddyboat with some Ha-Ha alumni. After we had independently confirmed that the weather forecast was good — "light and variable winds, picking up on Wednesday" — we took off. We approached Mazatlan on Wednesday, after running with — and surfing down — 12-ft seas that had been generated by 35-knot winds. Had we left a week earlier, we'd have had to motor across to Mazatlan, which wouldn't have been as exciting as the heart-pounding, sleepless nights we spent trying to keep our boat from broaching. We arrived in Mazatlan a little weathered and salty, but eager to see the mainland.

From Mazatlan we continued south to Isla Isabel. For those of you who skipped it, you made a big mistake. The clarity and color of the water was astounding, and the fearless boobies were hilarious. We loved that place so much that we stayed for a week, exploring, snorkeling, and even getting into a volleyball game with the local *pescaderos*. Despite playing with bare feet on a concrete court, their game is competitive.

Cruisers Head for Downwind Marine

Cruisers' Seminars

Meeting at Pt. Loma Assembly Hall • 3035 Talbot St., San Diego

Tuesday & Thursday Evenings at 7:30pm

Please join us as scheduled below. \$3/person

- Tues 10/09 Surviving a Haul-Out**, CF Koehler, Koehler Kraft
- Thurs 10/11 Staying Friends with Your Diesel Engine**,
CF Koehler, Koehler Kraft
- Tues 10/16 Abandon Ship! Outfitting for Safety at Sea**,
Bruce Brown, Switlik/ACR/SeaPac/Float Tech
- Tues 10/23 Provisioning for Mexico**,
Heather Stockard, Author and Veteran Cruiser
- Thurs 10/25 Self-Steering with Windvanes**,
Kopi Carmine, Scanmar International
- Thurs 11/01 Outboard Motor Needs for Cruising in Mexico**,
Tom Teevin, Aquarius Yacht Services
- Tues 11/06 Cruising Mexico with Charlie**, Margo Wood, Charlie's Charts
- Thurs 11/08 Cruising Baja & Sea of Cortez with Gerry**,
Gerry Cunningham, Gerry Cruising Charts
- Tues 11/13 Under Pressure! Pressure Cooking for Cruisers**,
Captain Steve Ford
- Thurs 11/15 Cruising on 12 Volts: Batteries, Alternators, Inverters – Tips & Troubleshooting**,
Barry Kessler, Xantrex Repair Tech & CEO, Altra Regulators
- Tues 11/20 The Frugal Cruiser**, Rod and LeNan Thompson, Veteran Cruisers

Welcome Baja Ha-Ha!



DOWNWIND
MARINE
THE CRUISER'S CHANDLERY
Open: M-F 8-5 • Sat. 9-5
(619) 224-2733
2804 Cañon St., San Diego, CA
www.downwindmarine.com
email: info@downwindmarine.com
CRUISERS' NET, Ch. 68
from 8:30 am weekdays: WHX369
*Boating is already fun –
We make it more affordable®*

Special Events for the Cruising Season!

- Tues 10/23 9am-4pm SAILMAIL MARINE COMMUNICATION SEMINAR**
Join Jim & Sue Corenman and Shea Weston for intensive training on Internet email service for cruisers
Point Loma Assembly Hall, 3035 Talbot St., San Diego \$50/person or \$75/couple
- Tues 10/23 8am-5pm SPECIAL BAJA HA-HA SPONSOR DAY AT DOWNWIND MARINE**
Tune up your cruising gear with the pros!
Check our Web site at www.downwindmarine.com for details.
Downwind Marine, 2804 Cañon St., San Diego
- Sun 11/04 12-4pm DOWNWIND CRUISERS' KICK-OFF POTLUCK BBQ**
We bring the beer, sodas, burgers and hot dogs.
Cruisers please bring a salad, side dish or dessert to share.
Meet other cruisers (families, friends and singlehandlers). Fun for all!
Shelter Island Beach (near launch ramp), San Diego (moves to store in event of rain)

Downwind Cruisers' Week

NOVEMBER 5-10 • Store Hours: 8-5 Mon-Fri, 9-5 Sat, Closed Sun • 2804 Cañon St., San Diego, CA

- **Wholesale Discount Prices** everyday...all week long for all customers. Yes, extra discount savings on what are already the lowest prices in town! Hey locals – don't let the cruisers walk away with all the great stuff you need too!
- **Morning Buddy Boat Meetings** everyday...all week • **Free Testing on 406 EPIRBs** everyday...all week
- **Manufacturer's Reps** available throughout the week. Valuable product info provided! Rep schedule posted at store and at BBQ. Extra special deals on manufacturer's selected items – this week only!
- **Special Give-Away** items for large purchases.



MASTERVOLT

THE POWER TO BE INDEPENDENT



MASS INVERTER/CHARGER

- Pure Sine Wave Inverter
- Available in 2kw & 4kw
- 3-step Battery Charging
- Light Weight & Compact
- Genset Support Mode



DIESEL GENERATORS

- Ultra compact, quiet
- Digital Remote Control Standard
- Whisper Compact Models: 3.5, 6, 8 & 12
- Ultra Whisper 1800rpm Models: 7, 9.5, 12.5, 15, 20 & 30kw



Vitrifrigo LLC AMERICA

REMOTE REFRIGERATION SYSTEMS

- All systems run on Low amp 12/24VDC
- 3 styles of Compact DC Condensing units
 - Air Cooled
 - Water Cooled
 - Keel Cooler
- Wide selection of Evaporators & Stainless Steel Holding plates with 12.5 ft line sets



DISTRIBUTOR



619-224-2869

www.southerncalmarine.com
1214 Rosecrans St
San Diego CA 92106

Southern California
Marine Enterprises

LETTERS

Sweet San Blas, our next stop, was so different from the tourist-oriented frenzies that we witnessed in Cabo San Lucas and Mazatlan. But the no-see-ums — ugh! My surfer husband had high hopes for Punta Mita, the first stop inside Banderas Bay, but it was raining and the waves were small. Nevertheless, we enjoyed some good hiking.

Many will find this hard to believe, but our seven-mile passage from Punta Mita to La Cruz featured some of the most drastic changes in the weather we've experienced. One minute it was raining and blowing 25 knots, the next it would be dry and we'd have to motor because the wind was so light. It took us an hour to reach La Cruz, where, unbeknownst to us, and because of circumstances beyond our control, we would end up having to spend more than a month.

Having anchored at the popular La Cruz anchorage, we made a number of trips to Bucerías and Puerto Vallarta but then, after 10 days, planned to continue on. We soon learned that it's foolish to make definite plans when cruising. We set our alarms for early on February 1 to depart La Cruz for points south. But before our clocks went off, we were awakened at 5:45 a.m. by the alarming sound of something violently slamming into our boat! Having just read an article about a sailboat having been hit by a ship, my immediate reaction was to think that we'd dragged anchor into the middle of Banderas Bay and been hit by a cruise ship.

Once on deck, we saw that a panga was impaled on the bow of our boat! And that there was chaos on the panga. "Está bien?" was all I could think to say in Spanish. "Why have you no lights?" a voice screamed back in broken English. But we did have an anchor light on. Matt turns it on every night, and because I'm always the first up, I turn it off in the morning. I later discovered that because panga bows become so elevated while they are underway, there was no way the driver could have seen us — or any of the other boats — in his path through the anchorage.

Before we knew it, the panga had been disengaged and abruptly rushed off. We were left to wonder if the collision had really happened, or if it was just a nightmare. But as we became more fully awake, the dark reality slowly started to sink in. We were in a foreign country where they have a different legal system, we weren't fluent in the language, and we'd just been involved in an accident in which somebody might have been injured. "Hmmm," I thought to myself, "I don't remember planning for something like this."

To be honest, the thought of just getting the heck out of there did cross our minds, as we thought we'd been involved in a hit and run, and didn't know what the consequences might be. But our sense of justice overcame our fears, and we did the right thing by reporting the accident to the Port Captain in La Cruz. While on the way there, we learned that one of the passengers on the panga had been severely injured — which explained why it had taken off so fast. Knowing that the accident involved a serious injury, things looked bleaker than before.

Using hand gestures and our limited Spanish, we tried to explain what had happened to the Port Captain. "Ustedes necesitan un traductor," he replied. Where does a cruiser in Banderas Bay go for information and assistance? VHF 22, of course. There were about 30 cruising boats in the anchorage, so we thought that surely someone would be fluent in Spanish and able to help us. Our gloomy mood was brightened somewhat by the compassion and loyalty expressed by fellow cruisers, and offers of help by folks such as ex-cruiser Philo, who runs the popular music bar in town. Ultimately, however, we were blessed by the assistance of an American who was

☎(510) 236-6633 • fax: (510) 231-2355
 yachtsales@kkmi.com • www.kkmi.com
 530 W. Cutting Blvd., Pt. Richmond, CA 94804

Ask us about our Maritime Protection Program to find out what a warranty can do for the purchase or sale of your yacht.



Swan 601 Moneypenny (2005).

This yacht exceeds the pedigree of her design, construction and the Nautor brand. Truly an extraordinary vessel whether your passion is to sail in world-class regattas or cruise in a high performance yacht.

\$2,975,000



Swan 112 Song of the Sea (2002)

One of the finest yacht produced by Nautor's Swan standing in a league with the super yachts. The vessel has been maintained to a very high standard and shows as new.



Nick Potter/Wilmington Boat Works 62' classic sloop (1938).

Designed by renowned Nick Potter for Jascha Heifetz, *Serenade* has been completely restored and is in pristine condition.

Asking **\$1,200,000**



Dubois Custom 50' (1989)

Custom two cabin cruising yacht designed by Dubois Naval Architects. Exceptionally well thought out cruiser with many details, *Norther* is robustly built, very comfortable and easily sailed short-handed.

Asking **\$650,000**



Nelson Marek Custom

A 92-ft aluminum world cruiser. Recently returned from a major refit in New Zealand, in perfect condition and ready to go again.

\$2,850,000



PRICE REDUCED

Nordlund 65 (1995)

Custom motor yacht designed for easy operation and comfortable living.

Understated and tasteful accommodations in excellent condition.

Asking **\$895,000**



SOLD

Hylas 46 (2002)

German Frers designed, Queen Long Marine built, cutter rigged, 2-cabin offshore cruiser. Selden in-mast furling, generator, full electronics and low engine hours. This yacht has been lightly used and in 'like new' condition.



WITH WARRANTY

Oyster 53 (1999)

A semi-custom yacht which includes numerous detailed appointments. Designed to be modern and coordinated, while remaining practical and durable at sea.

Now **\$849,000**



Santa Cruz 52 (1993)

Beautiful, fast cruiser, set up for short-handed sailing. Maintained to very high standards, the hull has been repainted in stunning red with new bottom paint.

\$490,000



WITH WARRANTY

PRICE REDUCED

Beneteau 473 (2001)

This 3-cabin Oceanis series cruiser is exceptionally clean. In-mast furling, a large cockpit, twin wheel steering, electric main and halyard winches make this boat very easy for a couple to sail.

\$225,000

Style. Fit. Performance.



Carlo Borlenghi Photo



See our website www.harken.com for our complete line of sailing gear.



HARKEN®

SAILING GEAR

Svendsen's Marine
Tel: (510) 521-8454

Fisheries Supply Co.
Tel: (800) 426-6930

LETTERS

crewing on a buddy's boat for a month. He not only spoke fluent Spanish, but had a winning personality as well. He stuck by us for two full days during visits to the Port Captain and, due to the injury of the passenger, the Ministerial Publico, which is similar to our district attorney. During this time we gave numerous reports of the unfortunate early morning incident. Before long, we learned that the panga that hit our boat had been going out on a fishing charter with Mexican tourists. Had he been heading to the east and the about-to-rise sun rather than the west and greater darkness, he might not have hit us.

The Mexican officials ordered us not to move our boat — it was evidence — until the Mexican Navy could conduct an investigation. And we as individuals were instructed not to leave the area until a judgement had been rendered. We didn't understand why there had to be an investigation, as it seemed obvious to us that the panga had hit our properly lit boat while she was anchored and we were asleep. But it was explained to us that in Mexico, both parties in an accident are presumed guilty until proven innocent. We also visited the driver of the panga and inquired about the condition of the injured man. It turned out that he was in serious condition — and would be for three weeks before being released from the hospital.

For the next month, we spent a lot of our time researching a series of questions: How could this accident have happened? Was our personal freedom in jeopardy? Could we lose our boat? And mostly, how long might the investigation take? To the latter question, we received some frightening answers. It might be months — or even years — before a decision was handed down. What sustained us during that difficult time was the love and support of fellow cruisers in La Cruz and our families back home. My mother-in-law was our biggest advocate, making contacts all over the United States and Mexico to get more information regarding our fate. She even contacted our Colorado Congresswoman, who worked with the American Consulate in Puerto Vallarta, with whom we had been in contact from the beginning. This was such a unique case that nobody could really provide us with answers to our questions. There was a lot of fear, too, most of it coming down from the United States. We were told how these situations usually were affected by corruption, greed and injustice. There



COURTESY SONADORA

Having been found innocent in the panga incident, Matt and April shared a romantic moment on their new pulpit.

was also the matter that we were *gringos*, and by Mexican standards appeared very wealthy.

For the record, our case was handled in a professional, fair — and by Mexican standards — very timely manner. Exactly a month after the accident, we received a judgement that said we had not been at fault. All the blame was put on the operator of the panga, as it had been determined that he'd been driving at an unsafe speed for the conditions.

We would never want to relive that experience, but believe that everything happens for a reason, and that reason was we — by necessity — got to experience Mexico on a much deeper

MKIV & CRUISING JIB REEFING & FURLING



J/100, J/Boats —
Billy Black Photo

EASY REEFING AND FURLING Multiple rows of Torton® ball bearings minimize friction for smooth furling.
STANDS UP TO THE ELEMENTS Deep-saturation Hardkote-anodized to resist corrosion from saltwater and sun.
INSTALLATION IS EASY Drum installs over existing turnbuckle; foil connectors easily slip onto the headstay wire.
INCREASED MECHANICAL ADVANTAGE Large inner spool diameter for powerful furling and reefing.

MKIV DESIGNED FOR PERFORMANCE RACING AND CRUISING SAILORS

MKIV furling systems are strong, lightweight and aerodynamic, with the performance and features Harken® is known for. Longevity, ease of use, and simplicity of installation are crucial components of the design.

AERODYNAMIC DOUBLE GROOVE FOILS and stainless steel feeder allow fast hoists, douses and sail changes—ideal for club racing.

LIGHTWEIGHT HALYARD SWIVEL turns freely, and reduces weight aloft to minimize pitching and heeling.

STACKED BEARING RACES evenly distribute loads to ball bearings so that foils turn freely under halyard loads.

IMPROVE UPWIND POINTING with independent halyard swivels that furl sail center before head and tack.

SPLIT DRUM AND LINE GUARD come off easily for use with full-hoist sails.



CRUISING DESIGNED SPECIFICALLY FOR CRUISING SAILORS

The Harken Cruising Furler is built of the same high quality materials as our performance MKIV furling systems, with strength, longevity, ease of use, and price crucial to the design. This furler is a must have, especially when sailing shorthanded.

ROUND SINGLE GROOVE FOILS withstand extreme reefing loads in high winds, rolls more easily than aerodynamic foil shapes.

STRONG HALYARD SWIVEL rotates freely on multiple rows of Torton® ball bearings.

STACKED BEARING RACES evenly distribute loads to ball bearings so that foils turn freely under halyard loads.



HARKEN®
CELEBRATING 40 YEARS

1251 E. Wisconsin Ave., Pewaukee, WI 53072, Tel: 262-691-3320, Fax: 262-691-3008, Email: harken@harken.com, Web: www.harken.com

FINANCE
YOUR DREAM
THROUGH OUR
WELL-CHARTED
WATERS



Seacoast Marine Finance offers more than the best rates, extraordinary expertise and a streamlined loan process. You can rest assured that your application is being handled by professionals who value your privacy and confidentiality. Don't drift into uncharted waters for assistance. Navigate to Seacoast Marine Finance, the premier haven for yacht buyers, dealers and brokers.

Call for your complimentary quote today.

Florida toll-free | 877-916-2326

California toll-free | 800-233-6542

Seattle | 206-784-7773



www.seacoastmarinefinance.net



A division of Seacoast National Bank

LETTERS

level than do normal visitors. Further, our bonds with friends, family, and each other were strengthened. And last but not least, our Spanish improved greatly, as on a daily basis we had to listen to it and speak it correctly for our own well-being. We want to thank everyone for their love and support — we'll never forget you!

And for all you cruisers who anchor in high-traffic areas, our advice is to light your boat up like a Christmas tree.

April Rollins
Soñadora, Catalina 36
Dana Point

April — We suppose that you can thank your lucky stars that you were in Mexico, where the legal system seemed to have worked properly, and not Clear Lake, California, where D.A. Jon Hopkins probably would have tried to prosecute you for being responsible for the accident.

We often anchor Profligate on the north shore of Banderas Bay, usually at Punta Mita, but also off La Cruz. When we do, we take April's advice, and really light up our boat. That includes the masthead anchor light, of course, but because it's not at eye-level for nearby dinghy and panga operators, that's just the beginning. We also leave a light on in the main salon which, because Profligate's a cat, can be seen from all around. In addition, we also turn on a light in each hull, which shows through to the outside from at least two ports per side. Lastly, we put garden-style solar lights on each bow and each transom. Given the amount of nighttime panga traffic going in and out of the panga marinas at both Punta Mita and La Cruz, lighting your boat up "like a Christmas tree" is important. By the way, we also use the same lighting scheme at Catalina, where boat operators can be just as reckless.

We don't want to come across as an old grouch who whines about safety all the time, but another area in which mariners aren't careful enough is with illuminating their dinghies at night. You are absolutely reckless — and operating illegally — if you don't have a bright light on your dinghy when you're moving at night. Think it's not important? It's been a few years, but a cruiser in his dinghy was killed after a hit and run by a fishing panga at Punta Mita. And as we reported last winter, a couple that were going ashore in their unlit dinghy at St. Barth to celebrate their just-completed circumnavigation, were run down by a big shoreboat for a megayacht. The woman was badly injured, the man was killed. It's also very common to see unlit dinghies rushing around off popular Catalina destinations at night. Please folks, you're playing Russian roulette. Have a light and wave it around so it can be seen from all directions.

↑↓A MODEST PROPOSAL

I have a modest proposal for the Lake County D.A. Jon Hopkins and his staff, who seem to be having trouble with the concept of what a safe speed would be for a boat on a lake on a moonless night. Since they apparently think that 45 to 55 mph would be a safe speed, we think they should have Deputy Perdock take them out for a night run.

Thanks for not letting this one go.

Tom Farr
La Crescenta

Tom — Great minds must think alike, because several days before we received your letter, we wrote the Latitude Safe Speed Challenge that appeared in the September's Sightings. The challenge would require D.A. Hopkins and Deputy Perdock to zoom around Clear Lake on a moonless night at 45 to 55 mph while various members of their families were aboard sailboats



VALLEJO MARINA

Gateway To The
Bay & Delta



Join us!
We love making new friends
and spoiling them!



**48-ft.
BERTHS
NOW
AVAILABLE**



- Competitive Rates!
- Great Restrooms with Showers
- Ample Guest Dock
- Full Service Boat Yard and Chandlery
- FREE Pump Out Stations
- Fuel Dock
- 2 Restaurants for Breakfast, Lunch, Cocktails and Dinner
- Covered and Open Berths
- Launch Ramp

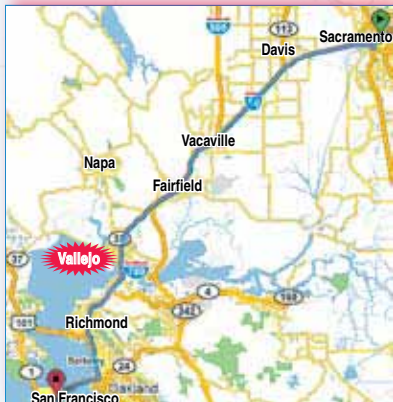

- One hour from Sacramento
- Only Three hours from Reno
- Easy access to San Francisco Bay and the Delta

**(707)
648-4370**

Fax 707-648-4660

42 Harbor Way • Vallejo, CA 94590 • www.ci.vallejo.ca.us



HONDA MARINE

& caribe INFLATABLES

IT'S ALL ABOUT POWER.



Caribe Light RIB combined with Honda 4 Strokes give you the best value on the market. Hypalon/Neoprene construction.

Light 8'	105 lbs.	\$2,427 Sale
Light 9'	110 lbs.	2,514 Sale
Light 10'	116 lbs.	2,862 Sale
Light 11'	138 lbs.	3,036 Sale

Honda 4 Strokes

- 2-225 hp
- Quietness
- Lightest Weight
- 3-yr. Warranty
- Reliability & Quality

For optimum performance and safety, read the Owner's Manual before operating your Honda Marine product. Always wear a personal flotation device while boating.



**HONDA
MARINE**
IT'S ALL ABOUT POWER.

Voyager Marine

1296 State St.
P.O. Box 246, Alviso, CA 95002-0246
(408) 263-7633 • (800) 700-7633
Open Tuesday thru Saturday



- Collapsible tenders from 7 ft. to 18 ft.
- 100% Hypalon
- New inflatable floor models:
LSI 88 **\$1,596 Sale**
LSI 96 **1,716 Sale**
LSI 104 **1,812 Sale**



Powered by
TOHATSU
outboards

5 HP Tohatsu **\$1,223 Sale**
6 HP Tohatsu **\$1,336 Sale**

Voyager Marine

1296 State St.
P.O. Box 246, Alviso, CA 95002-0246
(408) 263-7633 • (800) 700-7633
Open Tuesday thru Saturday



LETTERS

drifting in zephyrs.

THE CITY ATTORNEY TRIED TO FIGHT ME

I now live at the Ko 'Olina Marina on Oahu, but from June of '98 through September of '01 I lived in a beautiful home at Corinthian Bay, which is on the shores of Clear Lake. In fact, my home had a dock out back where I kept my Santana 25.

Clear Lake is a wonderful place to sail, with 10-to-15-knot westerlies almost every afternoon. Many times I sailed the four miles to Lakeport to have lunch or dinner, and I tried to catch as many of the summer evening concerts at Library Park as I could. For those, I would either cruise up and down in front of the park or take one of the side-ties and go ashore. Those events had such a great old-time, all-American feel to them.

I got to know Lake County pretty well, as I was the owner of a small business. As a member of a couple of local organizations, I had access to some of the well-traveled paths in this beautiful and historic place. I loved Lake County for what it had to offer, but also hated it for what others are now discovering about it — it's backward and inbred. Tradition is exalted in Lake County, while progress and change are not. The city and county government fiercely protect the status quo.

No matter where I've been, I've always tried to improve things. But I found that my attitude was not appreciated in Lake County. A partner and I invested in a lot on Main St. — yes, Main St. really is the main street — and began to build a commercial building. The lot was in an area where many visitors stayed and dined, but it was an eyesore, the kind of place where locals parked cars with 'For Sale' signs on them. You would think that the city would have jumped up and down with joy that someone was willing to help beautify the town. On the contrary, we were subjected to more scrutiny than a Mohammed at the San Francisco Airport. During a meeting with the City Manager, the City Planner and the City Attorney, I pointed out that the city wasn't acting like a partner with us in trying to improve the town. When I did, the City Attorney threatened to fight me. Let me repeat, the response on the part of the City Attorney was to try to fight with me.

With regard to safe boating on Clear Lake, I've been caught up in the stampede of boats that leave after a Friday night concert at Library Park. On one occasion, it was only the light of a large flashlight that saved me from being driven into the tullies by some folks on a large runabout. I managed to keep from being hit by them, but was terrified by the boats behind them doing 25+ knots in the dark and headed my way.

Clear Lake is one of the best bass fishing lakes in the country, and there are several professional bass fishing tournaments there every year. Have you ever had the pleasure of witnessing the start of a large bass tournament? It's 200 high-powered bass boats screaming off in all directions to find their fish. Clear Lake is also used to host high speed water-skiing contests, during which boats and skiers would reach speeds in excess of 90 mph. The point is that Clear Lake is home to boaters who like to travel at very high speeds. As such, I'm not surprised about the circumstances surrounding the death of Lynn Thornton.

Robert Montgomery
Ko'Olina Marina
O'ahu, Hawaii

Robert — After Dan Noyes of Channel 7 News did his fine investigation into the Thornton death and the Lake County D.A.'s handling of the case, a retired Lake County law enforcement official wrote a letter to the local paper decrying what he



MARINA RIVIERA NAYARIT
AT LA CRUZ



Marina Coordinates: Lat. 20°45'N • Long. 105°42'W

La Cruz de Huanacaxtle, Bahía de Banderas, Nayarit, Mexico
(322) 293 4064 • info@marinarivieranayarit.com

GRAND OPENING
December 2007



marinarivieranayarit.com



RESERVE NOW!

- UP TO 400 vessel capacity (30-350 ft.)
- Fuel station • Dry dock 150 ton travel lift • Yacht club
- Hotel Site • Condominiums • Restaurants & Bars
- First-class services and much more!



PEACEFUL, PROTECTED FIRST CLASS YACHT HARBOR



- Sheltered Alameda Location
- Competitive Rates
- Home of the Alameda Yacht Club

1535 Buena Vista Ave., Alameda, California
(510) 522-9080

For directions and rates go to:
www.fortman.com

LETTERS

described as Noyes' "feeding frenzy." Admitting that he knew nothing about boats, let alone intelligent analogies, he defended Deputy Perdock's traveling at an estimated 45 to 55 mph prior to hitting the boat Thornton was on. We found it interesting that he didn't mention what he thought a safe speed would be for a vehicle — without headlights or brakes — on a dark road on a moonless night.

↑↓ YOU DID IT JUST FOR ME

Did you do it just for me? I mean the September cover, with



The woman in the foreground is properly dressed and having fun.

a woman actively taking part in sailing, enjoying herself, and properly dressed for the activity. You lovely people! I shall keep this issue — it's timeless. Thank you!

And you included a piece on the Fastnet Race, in the country, England, to which I shall soon be returning. We will be living in a town called Truro, which is between Plymouth and Land's End. Therefore I'll watch the sailing scene, and I will send you material that might interest *Latitude* readers. After all, you go where the wind blows, and

I can tell you, it blows like blazes in Blighty.

Lyn Reynolds
San Jose

Lyn — If we were running for office, we'd lie and say we indeed did the cover just for you. But we didn't. It was just the most interesting photo for the cover that we could come up with and, in all honesty, we didn't pay any particular attention to the fact there was a woman in the foreground or what she was wearing.



Unlike newspapers in Britain, 'Latitude' would never run a picture like this!

— duh! — of so many Brit newspapers. You're going to have to work overtime to get rid of that Brit tradition. And if you do a charter in the Med, you're going to have to wear blinders to shield your eyes from the sight of those Euro women who

We're not going to get into the whole "properly dressed for the activity" business again, but frankly, we're a little worried about how you're going to fare back in Old Blighty. It's not that "the wind blows the dogs off the chains" that worries us, but the way scantily dressed women are found in inappropriate places millions of times a day. We're speaking, of course, of the partially — if at all — dressed Page 3 ladies found so prominently on page 3

Better Sail Control



now requires less effort...

Garhauer's adjustable genoa car system is the answer to leaving the cockpit and going forward to move the genoa car with every wind shift and sail adjustment.

Experience better sail control with less effort. With four to one purchase, you can now easily control the travel of a block on any track from a single line led aft.

This is a four piece system consisting of two control cars and two end controls (port & starboard). A single line threads thru the two horizontal blocks on the easily-installed track cars for each track. Your genoa sheet slides thru the pivoting vertical block and back to the winch.

Available in track widths of 1 and 1-1/4", built with rock solid durability that all Garhauer hardware is known for.

Now tack better and spend less:

E-Z G-1UB 1 in. track \$242.00

E-Z G-2UB 1-1/4 in. track \$302.50

E-Z G-3 1-1/4 in. track \$363.00

optional swivel cams available: \$96.80 per pair

**for sailboats
25-30' LOA**



E-Z G-1UB

**Optional
swivel cam on slide**

**for sailboats
30-36' LOA**



E-Z G-2UB

**Optional
swivel cam on slide**

**for sailboats
37-47' LOA**



E-Z G-3

**Optional
swivel cam on slide**



1082 West Ninth Street,
Upland, California 91786

Phone: (909) 985-9993
FAX: (909) 946-3913

email: garhauer@garhauermarine.com
<http://www.garhauermarine.com>



SeaPortal Ltd.
INTERNATIONAL
Marine Group



Swan 48 (1997). Royal blue Swan in excellent condition with a carbon rig, carbon furling boom, electric winches, full racing electronics, watermaker, and heating. Asking \$629,000.



Swan 48 (2003). The 2nd to last 48 built, this special Swan is like new and totally loaded. Less than 100 engine hours, bow thruster, electric winches, 3DL sails, full leather.



Swan 391 (1984). A Ron Holland designed Swan, this pretty little Swan has brand new teak decks, a new mainsail, radar, Harken furler, Navtec rod rigging, Quik Vang, and more.

SeaPortal Ltd.

Specializes in quality, ocean-going yachts. Whether you want to buy or sell, our international network of brokers, captains, and marine consultants can help meet your needs. Visit us at

www.seaportal.com

or call

(415) 999-6144

LETTERS

think nothing of stripping down to nothing on the dock for an after-sailing hose down.

↑↓ **MY MOM WAS ARRESTED FOR INDECENT EXPOSURE**

With all the concern some readers have expressed about the May issue cover photo featuring Lisa, I have to report that my mom was arrested on a beach in Canada because her one-piece swimsuit didn't have a skirt that came halfway down to her knees. Of course, that was in '32. So what if I am 81 years old?

Bill Steagall,
Inspiration

Channel Islands Harbor

Readers — People have written in about that cover for what, four out of the last five months? Pretty successful, no? By the way, we bumped into Lisa and her husband Wayne at the St. Francis Big Boat Series, and both of them were excited to be taking their J/120 J/World on the Ha-Ha and getting back down to Banderas Bay, Mexico. As for us, we're already planning the next mischievous cover, one we hope will have tongues wagging for a year.

↑↓ **GAUNTLETT FELL ON HARD TIMES**

I don't know if I qualify as a boat genealogist, but I'm a Farallone Clipper owner, a Corinthian YC member, the unofficial keeper of the Farallone Clipper Roster, and I also have a set of the Farallone Clipper One-Design Class pages from the PICYA Yachting Yearbook for the years '55-'65. From all of this, I can advise Paul Oz, who is trying to figure out who might have owned *Gauntlett*, and what to do with the trophies she won and he came into possession of. I can report the following:

Farallone Clipper #10 was launched in April of '55 and was originally named *Gauntlett*. Her first owner/charterer, according to the '56 Yearbook, was Robert Potter, a well-known sailor for the Corinthian YC. The '57 Yearbook shows that *Gauntlett* was then owned by Barbara Gauntlett of the Sausalito YC. I can't explain the coincidence of the name. The next yearbook shows that *Gauntlett* had been sold to H. D. Trask of the Aeolian YC and renamed *Hoyden II*. Bill's exploits with *Hoyden II* are legendary, and well known to any racer of that era.

After Bill's death, *Hoyden II* fell on hard times. For years she lay up in the summer heat and winter cold of Stockton, accumulating birds and bees under her covers. A couple of years ago, she was acquired by a professional boat restorer in San Diego. He partially completed an extensive repair, then lost interest. As I understand it, she's for sale in unfinished condition.

My guess is that the trophies in question were won by Bob Potter in the Corinthian Midwinters of '55-'56, '56-'57. I think that *Latitude's* suggestion of giving the trophies back to the Corinthian is a good idea, as they care about tradition and history. First, they will thank you profusely. Then they will complete the research on their history, clean them up, display them, and no doubt put them to some good use. The guy to call is Vice Commodore David Johnson, who can be reached at (415) 435-4771.

Gene Buck
Ouessant, Farallone Clipper
San Francisco

↑↓ **THE PRINCESS LOUISA FALLS WERE — WOW!**

I enjoyed the great *Sightings* update on Elizabeth Meyer

Built at Berkeley Marine Center



XL, looking fabulous under sail

The custom Antrim 40 was built at Berkeley Marine Center, and is now preparing for her first season of racing. We can build your fine yacht (or handle any repair or maintenance on your current fine yacht).

Call us to schedule your boat!



Lift capacity 35 tons

Sprayed Racing Bottoms

Full Painting Service

Fiberglass & Gelcoat Repairs

Rigging Repairs & Installation

Electrical Repairs & Installation

Engine Service & Repowering

Propeller Installation & Tuning

Wood Hull Repairs & Caulking

Teak & Non-Skid Deck Repairs

**Chandlery &
Fuel Dock
Open 7 Days**

Mon – Fri
8 am to 5 pm

Sat & Sun
9 am to 5 pm



In Berkeley Marina • 510-843-8195 • www.berkeleymarine.com

Sailing Away?

Call Today
for
Fall Pricing

We build custom
sails to suit your
needs, your boat,
your plans.



Keep cruising with
HOGIN SAILS



- New racing or cruising sails
- Roller furling conversions
- Boom and canvas covers
- Repair and service

In the Alameda Marina at
1801-D Clement Ave., Alameda, CA 94501

510.523.4388

Mon-Fri 8:30am to 5pm
Saturday by appointment only

sales@hoginsails.com
service@hoginsails.com
www.hoginsails.com

LETTERS

and the latest saga — cruising the Pacific Northwest with her husband Michael aboard their nearly 100-year-old 40-



COURTESY SEMINOLE

'Seminole' taking her shower.

ft Lawley schooner *Seminole* — of her living life large. One of my favorite possessions is a great framed print on my office wall of *Endeavour* — the J Class yacht that Meyer restored, and in the process revived the great class — in the San Juan Islands. In '95 *Endeavour* was docked near The Empress Hotel in Victoria, B.C., and I had the chance to look over the magnificent yacht while briefly

chatting with her crew. I was aboard a charter sailboat out of Friday Harbor and had just checked in with the Canadian Coast Guard when I saw the great yacht. While my several charters into B.C. waters over the years have never been as far north as Toba Inlet — where *Seminole* was taking her 'shower' in the *Sightings* photo, I will always remember the falls at Princess Louisa Inlet. The best time was when we sailed there on a rainy afternoon and docked for the night just downstream from the falls. Thanks to the rain that continued through the night, the next morning the falls were — wow! The additional water pouring over the falls made them that much more spectacular.

As a long-time subscriber to *Latitude*, I have a tiny beef. The disclaimer at the end of *Letters* dutifully instructs those who submit material to include name, boat name, hailing port, and contact info. Nonetheless, you proceed to publish letters hailing from "Planet Earth," "Name Withheld," with no boat name, and so forth.

The "Planet Earth" letters especially give me pause. For example, the September issue letter writer Paul Oz from "Planet Earth". Oz can't be his last name, it must be his internet moniker. And it was followed by — not again! — "Planet Earth." I betcha a lot of letter writers who own up to their real name and hailing port never get their letters published. I understand, you're the owner of *Latitude* and the *Letters* editor, and it's your prerogative to decide which of the volume of letters you receive to publish. Nonetheless, why have the detailed disclaimer when you don't follow it?

P.S. Why didn't I include my boat name? Because I don't own one. No doubt that explains most letters that appear without a boat name.

Jim Cox
Beaverton, Oregon

Jim — We don't know Elizabeth Meyer well, but we never got the impression that her life was about "living large." Both her parents were doctors, but apparently she made most of her money on her own, having been in Martha's Vineyard design and real estate at a time when it was appreciating wildly. When Meyer decided to take on the incredibly brave project of restoring Tommy Sopwith's 130-ft Endeavour, which was lying in the mud and in such poor condition that it couldn't be moved until the hull was repaired, she had to take out bank loans to

Why settle?



Ballena Isle Marina

Alameda 510.523.5528

Jack London Marina

Oakland 510.834.4591

Treasure Island Marina

San Francisco 415.981.2416

Martinez Marina

Martinez 925.313.0942

You don't settle for less, why do it with your marina? Join one Almar marina and gain access to seven Bay Area marinas. Almar's reciprocal program takes the hassle out of your boating weekend. A simple call to the marina office and you can spend the weekend at Jack London Square or Treasure Island. Maybe a trip to a few of Almar's seven Southern California marinas. We make it so easy you may find yourself using your boat.

Almar boaters receive a 10% discount on any fuel purchase at Jack London Square and Ballena Isle Marina. Jack London Square Marina has just upgraded it's fuel dock with high speed fuel dispensers and now has the fastest pumps in the Bay Area. You don't have to settle anymore.

Almar is the largest operator of saltwater marinas in the country. Almar Marinas provide a wide range of services and programs that few marinas or yacht clubs offer. Some of these programs include: monthly boating seminars, boat handling classes, navigation courses and organized outings to local anchorages. Each marina offers wireless high speed internet access, which can be used with your reciprocal privileges at any Almar Marina. To see the difference, visit one of our marinas this weekend.



almar.com

Sail Mexico Aboard the Schooner Seaward Winter 2008

Be part of the adventure

and learn the ways of the sea and sailing from professional mariners and ship-mates.

This is a hands-on experience where you can raise your level of sailing skills.



San Francisco to Channel Islands & LA Dec. 27-Jan 2 Designed for youth ages 15-19

\$750/student (limited scholarships available)

This sea educational program for teens packs adventure and learning into a 'rite of passage' that they won't soon forget.

Los Angeles to Cabo San Lucas Jan 6-17 \$1,350/participant

Designed for all ages and levels of sailing experience

Join in a true sea voyage as we sail the Baja Coast with whales and dolphins, anchoring in remote bays and islands along the way.

Puerto Vallarta & Banderas Bay area

Feb 19-24 \$1,000 & March 2-8 \$1,200/participant

Designed for all ages and levels of sailing experience Banderas Bay and the Gold Coast offer some of the best weather and sailing in Mexico. We will anchor off small islands, beautiful beaches and dine at local fish cantinas.

Puerto Vallarta to San Francisco March 12-March 28/31

Designed for all levels of sailing experience and those in good health. \$1,200/participant

This is a true ocean passage of almost 1,500 miles. We follow the clipper route north through changes in latitudes and attitudes, weather and wind. Become part of the rhythm of the sea on a passage that could take as long as 19 days.

www.seawardadventures.org

Seaward, an 82-ft USCG inspected vessel, is owned by Call of the Sea, a non-profit educational organization Connecting people to the sea

www.callofthesea.org • info@callofthesea.org
(415) 331-3214

LETTERS

do it. Talk about vision and courage in a woman of just 32! While the Endeavour restoration certainly brought Meyer a lot of publicity, we never felt she did it out of a Donald Trump-like need for attention. Indeed, the fact that she's continued to be such a prominent figure in the restoration of great yachts suggests to us that her love of sailing and great yachts always had a more spiritual motivation.

The "Planet Earth" homeport and/or other missing identification might bother you, but it drives us crazy! In these Internet and text messaging days, everybody seems to be on a first name — real or made up — basis, and they all reside in cyberspace. We can't tell you how many tortured hours we've spent over the years — especially in the pre-computer and pre-Google days — trying to track down complete information — full names, boat names, boat type, and hailing port — for each letter or Changes or article. We thought, and still think, that information is very important. Despite trying to email everyone back for all the info, we often still don't get it. And in the cases of some hand-written letters, we can't read the name or address.

Every time you read "Planet Earth" as the address for somebody, it means that we were unable to contact them for their complete address. We know Planet Earth sounds a little dopey. That's intentional, as we're trying to 'threaten' people with it in the hope they'll remember to include their hailing port or home address. In a perfect world, free of mitigating circumstances, and populated by people who weren't timid, we wouldn't publish letters that weren't signed. Alas, while the world is clearly getting better by the minute — ha, ha, ha — it's not quite perfect yet.

There are a number of factors we consider when evaluating a letter for publication — length, clarity, interesting factual information, entertainment value, and so forth. If we get two letters of the same 'quality', and one is signed and the other isn't, the latter doesn't make the cut. But while not being signed is a strike against a letter, it doesn't necessarily disqualify it. You're correct that as the Letters editor and publisher, we're the final arbiter of what letters do and don't get printed. We assure you that we do the very best we can, and hope that you're happy with the result.

↑↓MAYBE THE GOVERNMENT SHOULD BE PRIVATIZED

I lived aboard in the Ala Wai Yacht Harbor in Honolulu for 17 years, and can tell you that Roy Disney hit the nail on the head with his September letter about the problems with



ELECTRONIC / RICHARD

State officials seem unable to keep the Ala Wai on an even keel.

that marina. We watched the conditions in the Ala Wai deteriorate steadily for years until we finally had to leave. It's one thing for the visiting racers who come once every other year to have to deal with the deplorable and ever-declining condition of the docks, but something else entirely for those of us who had to live with it on a daily basis. It wasn't just unsightly, it was unsafe.

In the weeks leading up to the elections in Hawaii, we saw the various candidates for state and city office come to the



HAULOUTS 20' to 80'

HAULOUTS ON SHORT NOTICE...CALL US!



NORTHERN LIGHTS

GENERATOR SALES & SERVICE

WUGGER

MARINE ENGINES SALES & SERVICE

YOUR NEW FULL SERVICE **VOLVO PENTA** DEALER IN THE BAY AREA

PETTIT marine paint

FULL SERVICE BOATYARD:

- ✓ COMPLETE PROPELLER SHOP
- ✓ ELECTRICAL REPAIR & INSTALLATION
- ✓ FIBERGLASS BLISTER WORK
- ✓ LPU PAINTING
- ✓ COMPLETE MACHINE SHOP
- ✓ SHIPWRIGHTS - CAULKING & CARPENTRY
- ✓ GAS & DIESEL ENGINE SERVICE
- ✓ MAST & RIGGING REPAIR
- ✓ SANDBLASTING & EPOXY COATINGS
- ✓ FIBERGLASS & GELCOAT REPAIRS
- ✓ USCG CERT. WELDERS - STEEL/ALUMINUM
- ✓ INSURANCE WORK WELCOME

88-TON TRAVELIFT HANDLES UP TO 23' BEAM!

Online reservations now available at www.baymarineboatworks.com

BAY DESIGN & ENGINEERING

1-800-900-6646
(510) 237-0140 • Fax: (510) 237-2253

BAY PROPELLER
COMPLETE PROPELLER SERVICE

STEVE TAFT, MANAGER
310 WEST CUTTING BLVD. • POINT RICHMOND, CA 94804



SPECTRA
WATERMACHINES™

- Super efficient
- High reliability
- Worldwide sales and support



We have a watermaker to fit any need,
from 150 to 1000 gallons a day.

WEST COAST DEALERS

Emerald Harbor Marine, Inc.
Seattle, WA 98199
Tel: 206-285-3632
www.emeraldharbormarine.com

Svendsen's Boat Works
Alameda, CA 94501
Tel: 510-521-8454
www.svendsens.com

Channel Coast Marine
Oxnard, CA 93030
Tel: 805-985-0220
www.channelcoastmarine.com

Outbound Yacht Services, Inc.
Dana Point, CA 92629
Tel: 949-488-0652
www.outboundyachtservices.com

Daily Marine
San Diego, CA 92106
Tel: 619-222-9613
dailymar@aol.com



Your Dream, Realized.

Spectra Watermakers • Tel: 415-526-2780
www.spectrawatermakers.com

LETTERS

harbor for photo ops. Even Governor Linda Lingle was seen walking around with her entourage. Then D dock was condemned, and we were moved to the 800 row by the breakwater while "temporary" repairs were to be made. Temporary was an apt description. Almost immediately after, we were moved back to our old slip, where the dock had been "repaired" by bolting lengths of angle iron and sheets of plywood to the old floating dock. The result was that finger piers resumed breaking off and sinking, and the plywood sheets came loose, bringing back the familiar uneven tilting of the main floating dock. The only repairs that I've ever seen in the Ala Wai have been cosmetic in nature, temporarily hiding the real problems. After the elections, the politicians weren't seen or heard from, and repairs to B and C docks had not begun by the time we left the Ala Wai on May 26th.

The only plausible explanation for this disgraceful neglect is that it is part of a deliberate plan to eliminate pleasure boats from the Ala Wai. With fully half the slips condemned, and with no apparent effort on the part of the state to make real repairs, I can come to no other conclusion. This is especially true considering the buzz around the harbor from time to time that the front row is soon to be opened to commercial tour boats. This would require the removal of G dock, the only area in the harbor in serviceable condition, to accommodate the larger boats.

Disney is correct when he says that privatization is the answer. Unfortunately, there is more money to be made by kicking privately owned pleasure craft out to make room for more commercial operations. This, combined with the misguided efforts of a small but strident group of activists who protest every effort to privatize the marina, based on their fear of increased slip fees, means, I'm afraid, that the Ala Wai is destined to become an extension of Kewalo Basin. In other words, a commercial vessel basin that's more convenient for getting tourists to the tour and sportfishing boats. As for private yachts, there will only be room left in the Ala Wai for the privileged few.

Chuck Rose
Lealea, Albin Vega 27
Honolulu / Currently in Port Townsend, Washington

Chuck — We have what we think is a more plausible explanation for the neglect at the Ala Wai, which is that the state government is incompetent. Based on historical performance, we don't think they are capable of coming up with a "deliberate plan" for the Ala Wai — even a terrible one.

In our opinion, Disney's call for privatization doesn't go far enough. Pardon our cynicism, but we think the citizens of Hawaii — save for those employed by the state — would be best served if all branches of government in Hawaii were privatized. We're almost serious.

↑↓ HOW TO EFFECTIVELY USE THE MEXICAN SSB NETS

My husband Alan and I left to start our dream cruise aboard our Morgan 43 *Effie* three years ago in August from Santa Cruz, then traveled up the coast of California and into the Delta before heading down to Mexico. When we entered Mexican waters in November of '04, we were aware of the Amigo and Southbound cruiser nets, but were somewhat timid on the radio and not sure how they worked. We would 'lurk' at times, but never really had the courage to jump in.

After three years of cruising in Mexico, all that has changed. We use and enjoy the SSB all the time, and I even have a year's experience as a net controller. I can assure everyone that knowing how to use the Mexican SSB nets effectively is a big

Make Your First Ocean Passage a Great One!



LEARN WHAT IT TAKES...

to make a major cruise under sail during our 23rd offshore sail training voyage. Our 2008 schedule offers you a choice of shorter excursions in prime cruising areas, exotic landfalls and classic ocean passages.

Our emphasis is on helping you build skills in an environment of fun and great sailing. Many who sail with us are planning voyages of their own—there is no better way to prepare. Underway, we provide in-depth experience in vessel management, safety, provisioning, electrical and plumbing systems, celestial navigating, anchoring, sail handling, weather routing, and heavy weather.

Along with eight other crewmembers, you'll sail in all conditions, standing watches and steering as *Alaska Eagle* sails 180 to 240 miles a day. Delicious meals are prepared by the ship's cook. Everyone has a comfortable berth, and double cabins are available for couples and single women.

Alaska Eagle is owned by one of the nation's premier non-profit sailing schools. Designed by Sparkman & Stephens and strongly built of aluminum by the Royal Huisman Shipyard, *Alaska Eagle* (ex Whitbread winner *Flyer*) has logged more than 350,000 offshore miles. She has a comfortable four stateroom interior and all the latest electronics and cruising gear. She is Coast Guard certified for All Oceans.

2007/2008 SKIPPERS – Sail and Learn with the Best



Since Rich and Sheri first sailed aboard *Alaska Eagle* from England to California in 1982, they have been aboard as skipper and mate for the majority of her voyages. Combined, they have sailed more than 550,000 miles, including three Atlantic crossings, more than 30 crossings between Hawaii and the West Coast, 13 equator crossings, and many miles through the South Pacific between Tahiti and Australia. In between, Rich and Sheri have built three boats, virtually by themselves. In their first boat, a Farr 44, they circumnavigated South America. Their next boat was a 54 foot aluminum sloop in which they voyaged to Antarctica. Their third boat, the Farr 44 *Tabu* has just been launched and is ready for adventure.

Licenses held: USCG Master Upon Oceans • STCW International Yacht Master (RYA/DOT) • US Sailing Instructor: Keelboat, Cruising, Coastal Navigation

ALASKA EAGLE VOYAGE SCHEDULE

Auckland – Bay of Islands – Auckland

Feb 2 – 11 or Feb 14 – 23, 2008

Starting and ending in Auckland, these coastal trips will explore the Coromandel Peninsula and the beautiful Bay of Islands.

Auckland – Raiavavae – Tahiti

May 15 – Jun 5, 2008

Predominately an upwind passage, heavy weather and an exotic landfall combine to make this a challenging voyage.

Tahiti – Raiatea

Jun 9 – Jun 18, 2008

Starting from the rollicking Papeete waterfront, you'll sail to the exotic islands of Moorea, Huahine and Bora Bora before finishing in lovely Raiatea.

To learn more: occsailing.com

To request a color catalog or

specific info: **949-645-9412**

Or write: Alaska Eagle Voyages, 1801 W. Coast Hwy, Newport Beach, CA 92663

Raiatea – Fanning – Hawaii

Jun 22 – Jul 12, 2008

Leaving the legendary island of Raiatea, this passage includes a stop at Fanning Island and an equator crossing officiated by King Neptune.

Hawaii – San Francisco

Jul 15 – Aug 1, 2008

Conditions range from upwind sailing and squalls to exquisite reaching conditions. Sailing under the Golden Gate Bridge brings a picture perfect ending to this trip.

San Francisco – Newport Beach

Aug 4 – Aug 8, 2008

For those wanting a taste of the voyaging life, this short coastal passage will include stops in San Miguel, Morro Bay or Catalina (conditions permitting).

The School of
SAILING & SEAMANSHIP
Orange Coast College

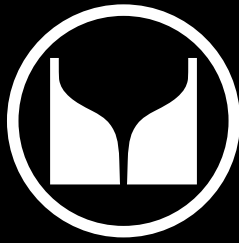

SVENDSEN'S MARINE

AMERICAN BATTERY

Deep Cycle Battery

12 Volt, 85 amp

Your best choice
for house batteries.
ABT 24TM

LIST PRICE: \$104.68

SALE PRICE:
\$71.00



PERKO®

Battery Switch 8501 DP

ON/OFF/BOTH
PKO 8501 DP

LIST PRICE: \$46.40

SALE PRICE:
\$27.84



xantrex

Truecharge 20+ 20 amp, Multi-stage Battery Charger

Microprocessor
controlled for fast and
accurate charging
of all deep-cycle
batteries.

XAN 804-0220

LIST PRICE:
\$340.00

SALE PRICE:
\$289.00



PRICES VALID THROUGH OCTOBER 31, 2007

LOCATED IN THE ALAMEDA MARINA

1851 Clement Avenue, Alameda

CHANDLERY: 510.521.8454 • BOAT YARD: 510.522.2886

LETTERS

benefit, especially when underway, because it allows you to check in with fellow cruisers and get the latest weather from Don of *Summer Passage*.

As someone who was a timid SSB novice just a couple of years ago, I'd like to share my knowledge with this year's group of SSB novices, and encourage all of you not to be afraid of SSB nets. If I can become competent at it, so can you. Here are the basics:

1) SSB stands for Single Sideband marine radio. You use your ship's radio call sign when checking into the net. You do not need to have a ham license to use your ship's call sign or to check into the nets. If you buy a radio like an Icom 802, it has to be enabled to transmit on ham frequencies, so don't worry about doing that by accident.

2) The Amigo Net comes on at 1400 zulu on 8122 USB (upper side band), while the Southbound Net is at 0145 zulu on 6156 USB. The Southbound Net may change by an hour once the season starts. If you're not sure when zulu time is, scroll through your GPS. It's also good to have an inexpensive digital clock near your radio that is set to zulu time.

3) Both the Amigo and Southbound are 'controlled nets', which means you must be recognized by the net controller before you check in. When the net controller asks for check-ins, respond with your boat name only. Net controllers usually take a list of boat names, and when it's your turn to check in, they will call you back and say something like, "Effie, come ahead with your check-in." At that time you respond with something like, "Good morning net, this is the sailing vessel Effie, WDB6206, with Margaret, Alan and boat cat Maggie aboard. We're currently anchored in Agua Verde where we have 5 knots of wind out of the southeast and flat seas. We have no traffic."

4) It's important to denote the type of vessel you are on and how many 'souls' — as Don of *Summer Passage* would say — are aboard. That's because net controllers keep records of vessels checking in, so if there is ever a problem, they know the boat's most recent position and how many people were aboard.

5) Underway vessels always receive priority, and are asked to check in first or will be put ahead of any other vessels checking in. When checking in underway, you give your last location, your destination, your coordinates, and the current weather conditions. For example, "Good Morning net, this is the sailing vessel Effie, Whisky Delta Bravo 6206, with Margaret, Alan and boat cat Maggie aboard. We're currently underway from Cabo San Lucas en route to Mazatlan. Our current position is 22 degrees 50 minutes north, 108 degrees 59 minutes west. We have 20 knots of wind out of the north-west with four to five foot swells. We have no traffic."

It's important to talk slowly and clearly. It's also important to give positions in degrees and minutes, and in single digits. For example, Two Two (not twenty-two) degrees, Five Zero (not fifty) minutes north, One Zero Eight degrees, Five Niner (use niner not nine) minutes west.

6) 'Traffic' simply means you want to check in with another vessel. If you want to call another vessel at the end of your check-in, simply state, "I have traffic." The net controller will say, "Go ahead with your traffic," at which time you then call your traffic: "Java, Java, Java, this is the sailing vessel Effie calling." If you are unable to reach them, the net controller will usually try to call them for you. It's important to keep the conversation short. When you are done with your conversation, you notify net control by saying, "Thanks net control, this will be Effie clear (or standing by)." "Clear" means that you are leaving the net, while "standing by" means you're



Yacht Sales & Service - San Diego



65' J 65 "Brand New Day"
Call For Pricing



42' Hinckley SW, 1987
\$329,000



2002 C&C 121 Xpress 'Anasazi'
\$215,000

FEATURED LISTINGS



34' J/109, 2004 ~ \$225,000



40' Delphia, 2007 ~ \$203,206

2006	65'	J/65, <i>Brand New Day</i>	Call for pricing	2002	40'	C&C 121 Xpress, <i>Anasazi</i>	\$215,000
1990	46'	Wylie, <i>Stardust</i>	\$349,000	2006	37'	Delphia	Base price \$152,127
1983	46'	Swan Hull #1, <i>Equity</i>	\$309,000	2004	34'	J/109, <i>Zephyr</i>	225,000
1987	42'	Hinckley SW, <i>Alcyone</i>	\$329,000	2007	33'	Cross Current, <i>Electra</i>	Call for pricing
2005	42'	Renzo PT Runner 4.0.....	Call for pricing	2005	33'	J/100, <i>Faster Horses</i>	\$119,000
2006	42'	Renzo Express 4.0.....	Call for pricing	2007	33'	Delphia	Base price \$130,823
2006	42'	Renzo Coupe 4.5.....	Call for pricing	1984	29'	J/29, <i>Zulu</i>	25,000
2006	42'	Renzo Coupe 4.0.....	Call for pricing	2007	25'	Hunt Harrier.....	\$175,000
2006	40'	Delphia, 2007	Base price \$203,206	1993	26'	J/80, #71.....	\$27,500
1998	40'	J/120, <i>Scamp</i>	\$220,000	2004	26'	J/80, <i>Jim</i>	\$32,000
1998	40'	J/120, <i>Shenanigans</i>	SOLD	2001	26'	J/80, <i>Whiplash</i>	\$33,500

Sell your boat with us we are always looking for quality listings.



Yacht Sales & Service
- San Diego

New Satellite Office
Opening in
San Francisco

2330 Shelter Island Dr. #106
San Diego, CA 92106
PH: (619) 224-6200
FAX: (619) 224-6278
Jeff Brown John Bohne Ken Bertino
www.jk3yachts.com



Dealers for
San Diego
and Hawaii



WEST COAST YACHTS™



NAUTICAT 39' \$419k | 2003

Great sailing with inside steering station. Loaded with options; genset, watermaker, optional bowsprit, double freezers, etc.



TRANSPAC 49' \$235k | 1986

Luxurious, roomy, liveaboard or blue water cruiser with open teak interior. In Seattle.



SWAN 411
\$104,500 | 1979
Price reduced!
Clean and pretty
Swan, ready
for new owners.



HR 39' \$279k | 1995

New listing for a very clean HR 39. In-mast furling, only 530 original engine hours!



CAPE GEORGE CUTTER 36' \$169k | 1981

Totally refit and modernized!
New engine, electrical,
rigging, epoxy and bright-
work. Totally beautiful.



HR 36' \$285k | 2000

Used for one offshore sail. Monitor vane, SSB, Spectra watermaker, and more!



R Hallberg-Rassy

1800 Westlake Ave. North, Suite 201 Seattle, WA 98109
www.westcoastyachts.us | info@westcoastyachts.us
206 298 3724

LETTERS

done with your conversation but still tuned into the net.

7) Fifteen minutes after the net starts, Don from *Summer Passage* comes on to give his weather report. He first gives us any official warnings, then short term, and finally long-term reports. He starts on the outside of the Baja, then does the Sea of Cortez, then the Cabo San Lucas to Mazatlan crossing, and finally, mainland Mexico down to Zihuatanejo. When Don refers to the "Southern Triangle," he's talking about Cabo Corrientes, Cabo San Lucas and Mazatlan. For those of you heading further south, there are other nets and times Don monitors the radio. Simply ask any net controller, and they will be happy to email you a copy of Don's schedule.

Please note that Don typically gives weather for 20 to 50 miles offshore. Due to the complexity of the coast line, Baja terrain, and land masses, it's almost impossible to give an accurate coastwise forecast.

After Don gives his report, the net controller will ask for any questions. Again, give your boat name only after the net controller recognizes you and tells you to go ahead and ask your question. When recognized, give your boat name and location, then ask your question. It's frustrating for not only Don and the net controller, but everyone else listening, if people ask the same questions for the same locations again and again. Also know your location in relationship to other locations. For example, if you're in Muertos and you hear the weather for Los Frailes, assume that your weather will be the same. Please don't call in and ask for weather specifically for Muertos, since it's only 47 miles from Los Frailes and the weather won't be much different. Don does a great job covering all the areas, however there are times when a boat cannot hear Don or they need clarification. In those cases, feel free to ask a question if needed.

By the way, Don volunteers his time a dozen different times during the day to help his fellow cruisers. His services are greatly appreciated by all of us.

8) After the weather, the net controller will continue to take check-ins. First, they will again take vessels underway, then ask for any announcements. Announcements are usually reports of hazards, harbor closures, and so forth. After announcements, the net controller will ask for "General Check-Ins."

The Southbound Net stays on 6516 USB for general check-ins and until the end of the net. The Amigo Net switches to 4B (4149 USB) to continue with General Check-Ins unable to get through on 8122. After switching to 4B, the Net Controller will ask for any further weather questions for those who were unable to hear Don on 8122.

The Mexican cruising nets are a great way to keep in touch and hear local weather conditions. In addition, on numerous occasions they have helped boats in trouble. So don't just lurk, but use the tips above to jump in and enjoy.

Margaret 'Mac' and Alan Mathison, and La Gata Maggie Effie, Morgan 43 CC Santa Cruz / Currently in Ensenada about to head south

Margaret — Fine report. It's funny, but lots of people are almost as afraid of getting on the SSB nets as they are of getting a root canal. But once they do it a couple of times — get on a net, that is — they quickly lose the fear.

For those who will be doing the Ha-Ha, the major differ-

LELECTRONIC / RICHARD



Mac and Alan encourage you to visit with them on SSB.

For more than 20 years, yacht owners have been able to trust **PACIFIC COAST CANVAS** for the best in design, service and quality.

- **Offshore Dodger™**

Welded aft handrail
Bolt-on side handrails
Lexan windshields

- **Baja Awning™**

Lightweight and waterproof
Durable and easy to launch
Multiple side screen configurations



Tom & Kathleen Wolinsky set for summer fun with a new Dodger & Cruisers Awning on their Beneteau 373!

- **Coastal Dodger™**

Affordable designs
Same high quality materials
Same superior workmanship

- **Cruiser's Awning™**

Easy setup off your dodger
Flies with no bulky frame
Comes with shade screens

Open Monday-Friday 8:00-4:00
Saturday by appointment
(510) 521-1829



**2021 Alaska Packer Place
Alameda, CA 94501
Grand Marina**

NEW COAST FABRICS
EST. 1972



*Distributor to the automotive
and marine aftermarket.*

New Coast Fabrics is a distributor for



Polish and Plastic, Canvas and Vinyl Cleaners

Inflatable Boat Cleaner is an easy-to-use biodegradable cleaner. Dissolves dirt, oil, creosote, diesel soot and scuff marks on inflatable boats, fenders, rub rails, etc.

Super Swabby Bilge Cleaner dissolves oil, grease, gasoline, scum and sludge, leaving a clean fresh scent. Biodegradable.

Boat Wash with Carnauba Wax cleans and maintains waxed finishes on boats, cars, planes and recreational vehicles.

*We also carry complete lines of marine vinyls,
carpets and WeatherMax outdoor fabric.*

NEW COAST FABRICS

1955 Davis Street, San Leandro, CA

800.772.3449

**Gori®
propeller**

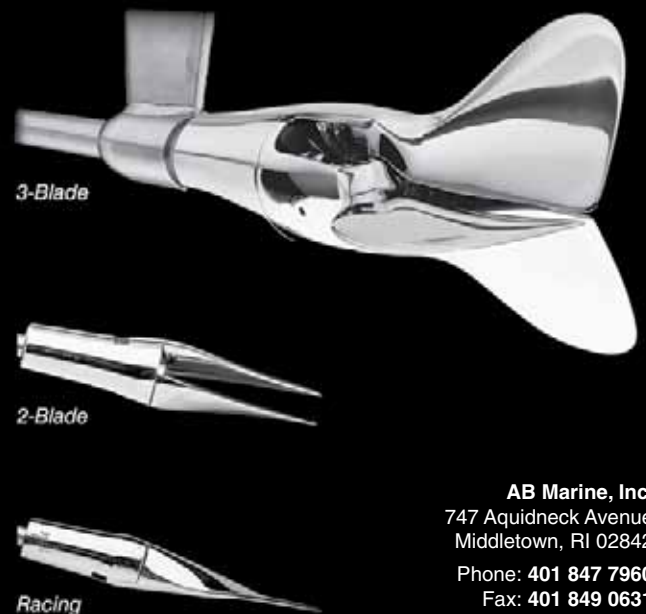

3-Blade

2-Blade

Racing

AB Marine, Inc.
747 Aquidneck Avenue
Middletown, RI 02842
Phone: 401 847 7960
Fax: 401 849 0631
sales@ab-marine.com
www.ab-marine.com

The 'Re-berth' of Paradise Cay!



Luxury townhomes with gated access and private elevators from \$1,575,000.

Single-family residences from \$2,500,000.

Elevate your style of living at Tiburon's newest waterfront enclave, at San Francisco Bay's newest marina. Our large and luxurious townhomes have private elevator access available, so you can live on all three levels overlooking San Francisco Bay without ever climbing the stairs.

Or choose one of our splendid single-family homes (seven with private, 60-foot boat docks) that redefine the concept of waterfront living. Open daily 10 a.m. to 6 p.m.

Broker Cooperation
tiburonmist.com (415) 435-1342



TIBURON MIST
 240 Trinidad Drive At Paradise Cay



LETTERS

ence between the Ha-Ha net and the other nets is that when giving your position, the Grand Poobah asks you to please, please, please don't use single digits unless necessary, and don't include the words "degrees" and "minutes." For example, if you're at 22 degrees, 30 minutes north, by 122 degrees, 18 minutes west, all the Poobah wants is "twenty-two thirty, one twenty-two eighteen." It should take about five seconds. If all 170 or so Ha-Ha entries gave their positions in the approved way for the Southbound and Amigo Nets, and included all the degrees and minutes, it would take forever. Once the Ha-Ha is over, please resume doing things the 'right way'.

↑↓SEA YA, WOULDN'T WANT TO BE YA

We always conduct man overboard drills on the second day of our sailing classes for beginners. But it didn't go so well on September 2 at 1:45 p.m. while a mile north of the Bay Bridge and about 100 yards off the pier on the west side of Treasure Island. For over an hour, my three students on a Santana 22 had successfully been retrieving our float — simulating a man overboard — in drill after drill. Then a sloop with a yellow stripe below the gunwhale named *Sea Ya* came out of the Oakland Estuary and interfered with us. And more. Despite our waving them off, shouting to them that we were doing emergency drills, and sounding five blasts on our horn three different times, they continued to tack back and forth in an attempt to get our float. At one point their maneuvering put us in danger of a collision.

Upon returning to South Beach Marina, I made inquiries at the Harbormasters office. They showed that three boats named *Sea Ya* had taken guest slips there. My sympathy to the owners of the *Sea Ya*'s that weren't involved, but to the owner of the *Sea Ya* that was, try to see the larger picture.

Oliver Gildersleeve

Sailing Instructor for 23 years on San Francisco Bay

Oliver — It seems to us that there must have been some kind of misunderstanding, for who would want to steal something of as little value as a float, particularly when somebody was yelling at them. Is there somebody from Sea Ya with an explanation?

↑↓WE HAVE A PHOTO TO SHARE

My friend Gerry Schumacher took the accompanying



GERRY SCHUMACHER

photo as these sailors crossed the bow of his trawler. If a professional photographer had snapped a similar photo of my Slocum 43, I would sure like a copy. So maybe you could run the photo

Nice boat, nice photograph.

and hope that someone who knows these folks will see it.

Mark Wieber
 Planet Earth

Mark — We've happily done as you suggested.

↑↓IT'S BYOB IN PALMYRA

I had to comment on the article about Palmyra in the Au-



**ESSEX
CREDIT**

NEW - USED - REFINANCE

Boat Loans Made Easy®



Let our 26 years of experience go to work for you!

Linda Carroll

866-377-3948 ext. 7215

www.essexcredit.com

EQUAL CREDIT OPPORTUNITY LENDER

Loan Amounts from \$15,000 Instant Loan Approvals*
Zero Down Program* 90 Days to First Payment*

*(Subject to Loan Program Guidelines and Credit Approval)

Reference Code =MAR931

Design and Upholstery

Just for Your Yacht!

CALL US TODAY!

NORTH BEACH MARINE CANVAS

YACHT:
CARPE DIEM

415.543.1887; nbmc@earthlink.net
www.northbeachmarinecanvas.com
Pier 40, South Beach Harbor, San Francisco

**REPAIR
REPAIR
REPAIR**

**ROOSTER SAILS
A REPAIR LOFT**

- CRUISERS' REPAIRS
- FAST TURNAROUND
- RACING REPAIRS

YOUR ROLLER FURLER UV COVER SPECIALIST

ROOSTER SAILS

451 West Atlantic Ave., Alameda Pt. (Alameda Naval Air Strn.)
(510) 523-1977

www.roostersails.com • rui@roostersails.com

Open M-Th 9-6 • Fri 9-5 • Sat by appt.

Owned and Operated by Rui Luis • Experienced Sail Repair and Fabrication

NOW OFFERING NEW CRUISING SAILS!

SAIL REPAIR SPECIALISTS • COMPETITIVE RATES • RECUTS • CONVERSIONS

**SOUTH
BEACH**
H·A·R·B·O·R

South Beach Harbor
is a great way to experience San Francisco.
Boats of all sizes are welcome in our
protected deep water harbor. Bring your
boat to South Beach and enjoy all the
attractions of the city.



Two guest docks for boats
up to 125'

20 guest berths up to 50'

Casual and fine dining nearby

Adjacent to AT&T Park

Easy access to transportation

24 hour security

Free pump-out stations

For Reservations:

415.495.4911
fax: 415.512.1351
sb.harbor@sfgov.org
www.southbeachharbor.com

LETTERS

gust 22 *Lectronic*. I spent three weeks on Palmyra last summer on a research and collecting trip with the California Academy of Sciences (CAS). We did most of our diving in the lagoons and saw some white tip and black tip sharks, but no threatening shark species. On the first dive outside the reef, we were passed by an 8-to-10-ft tiger shark that was cruising by but didn't threaten us. There were about 15 divers that went out every day, but none were ever bothered by any sharks. Many of the scientists also did snorkeling, but didn't have any shark confrontations either. I imagine that if you were fishing, the catch might be in danger, but not humans.

By the way, the Palmyra YC does not have any beer for sale. You can only drink what you bring with you, but we didn't bring any. There is no bar or bartender, but there is a lending library and facility for lectures and movies.

The Nature Conservancy has provided a wonderful facility for research, with an outstanding laboratory, comfortable two-person cabins, excellent food, and a very safe and well-equipped diving program. A charter plane comes in every two weeks unless delayed by weather or mechanical problems.

Each research team must provide a lead diver who is responsible for all of the dives in his/her group. We had teams from The American Museum of Natural History in New York, Scripps Institute of Oceanography, UC Berkeley and CAS, San Francisco. My role was as dive instructor/diving medical officer for CAS. There is careful adherence to established safe diving tables and computers. The nearest recompression facility is four hours away by air after the plane gets to Palmyra, which is four hours away itself. All this assumes that the plane would come instantly, and that's highly unlikely.

Allen Dekelboum, M.D.
Black Coral, Bayliner 3870
Tiburon

SHARKS RULE

The photo you ran of the "Palmyra YC" in a recent *Lectronic* brought back many pleasant memories. My husband Eric and I sailed our Flying Dutchman 37 *Nataraja* to Palmyra from Hawaii in May of '02 on our way to the South Pacific. A year and a half later, we left *Nataraja* in Ketchikan, Alaska, and flew back to Palmyra to work for the Nature Conservancy for three months.

It's true that there are sharks inside the lagoon, but they are the smaller black tip sharks. We spent many afternoons in



EMMY NEWBOULD

Just because you hook a fish off Palmyra, doesn't mean you won't have to share it with a shark.

the swimming hole inside the lagoon and never had any problems. We would see an occasional curious black tip, but they kept on going. They have no interest in people because there is plenty of other food. Outside the lagoon, however, is a different story. Fishing was always exciting, and once someone hooked up the game was on. Many times we saw the jaws of a shark snap down on a fish that we were trying to land. It made for some very exciting moments.

Palmyra is truly a magical place with an incredibly

The Adventure Begins Here!



*Outstanding Professional Education for
New and Seasoned Mariners*

Enroll Now for Fall Classes

- The License School: OUPV, 100 Ton Upgrade, plus Towing and Sail Endorsements
- STCW Basic Safety Training (First Aid/CPR, Personal Safety and Social Responsibilities, Personal Survival, and Basic Firefighting)

See all instructor led and online classes at
www.maritime-education.com

To enroll, call **707-654-1157**



The California Maritime Academy, located in Vallejo, California, is a specialized campus of the California State University.

MARINE INSURANCE

Global Coverage • Personal Service
*Unbeatable experience to match
your needs to the right product.*



Insurance made simple, affordable and effective.

TWIN RIVERS MARINE
INSURANCE AGENCY, INC.

7 Marina Plaza, Antioch, CA 94509 LIC # OE32738

www.boatinsuranceonly.com 800-259-5701



After 25 years as the nation's leading marine outfitter and safety expert, Landfall Navigation is now simply Landfall. We're shortening our name. Expanding our product lines. Issuing more catalogs. Redesigning our website. But one thing endures: our commitment to safety. So whether you need to outfit a dinghy or a maxi yacht, think safety first – think Landfall.

SAVE \$25 To celebrate the new Landfall, for a limited time save \$25.00 when you spend \$150.00 or more. Use promotional code EK0101 at checkout to receive your savings.*



Phone: 800-941-2219 | Online: www.landfallnav.com | On Land: Stamford, CT

*Not to be combined with any other promotion. Limited time offer expires 12/31/07. © 2007 Landfall Navigation. All rights reserved.



Don't Let This Happen To You!

Marine AIS Receivers

Give your navigation software or chartplotter the power to see shipping traffic.

Prices start
from only
\$189!



**Why Leave Your –
And Your Family And Crew's –
Safety to Chance?**

Commercial ships now use AIS transponders. Map nearby ships with supported navigation software and chartplotters connected to one of our low cost AIS Receivers.

For more information visit:

www.MiltechMarine.com

Or call us at:

**Milltech Marine
425-818-5246**

LETTERS

healthy ecosystem. We consider ourselves very lucky to have been able to visit there and experience its unique beauty.

Emmy & Eric Willbur
Nataraja, Flying Dutchman 37
En route to the South Pacific

↑↓THE OTHER BOAT DESTROYED THAT NIGHT

In the last issue you reported on *Grunt*, the powerboat that caught fire and sank at Catalina, but also the powerboat



STEVE PRICE

Crescendo that sank after running into the Newport breakwater earlier that night.

When boats do battle with breakwaters, you can bet that the breakwater's going to win.

On his way back from Catalina on Tuesday, a friend of mine snapped this photo of *Crescendo* which, after a lot of time and expense, had finally been raised and was being towed into Newport Harbor. The rumor is that the owner is being fined big time for the oil and fuel spill the sinking caused.

Steve Price
Hula Girl, CHB 34
Southern California

Steve — Having been in and out of Newport Harbor many times, we're still having a hard time understanding how it's possible to run into the breakwater when the visibility is reasonably good.

↑↓TOGA-WEARING TORTILLA WARRIORS

Unless you're ocean racing, it's unusual to see any sailboats once you get 100 miles offshore. Indeed, it had never happened to me before this summer when I delivered the Schumacher 39 *Recidivist* from Honolulu back to San Francisco. But during this year's 'TransBack', it was proved to me that small boats do exist outside the edges of my toerail on the big ocean. For not only did we see another rag boat, we saw four of them! We even had a crossing situation one night that was so close that we actually had to give way — although I'm not sure that anyone on the other boat even saw us. I suppose it would have been almost funny for two small sailboats to have collided in the middle of the ocean.

We passed our first boat — an old full-keeler that was being singlehanded — about 300 miles north of Oahu. The only thing hi-tech — or even shiny — on his boat was his windvane steering system. He didn't have much else on that boat except perhaps a VHF radio. We gave him a "Hello thar matey" as we passed, and he gave us the old thumb and pinky Hawaiian sign. Since he seemed so content, the three of us on *Recidivist* proceeded to give him a 'three-moon salute', thinking that would make his day. In any event, our much lighter boat with a high aspect rig quickly left him in our wake.

We later saw a second sailboat, but she was too far to the west of us to deal with. They reached off into the sunset to avoid the train wreck-like bashing sounds you get when sailing close-hauled on a skewed sea. We never saw boat #2 again.

The third sailboat we saw, the 'Benny' 40.7 *Inspired Environments*, which had departed the Ala Wai Yacht Harbor six hours before us, would turn out to be our nemesis. We had been in daily communication with them and many other returning TransPac boats via SSB 4A since leaving Hawaii,

Featured Trade-In
SWEDEN YACHTS

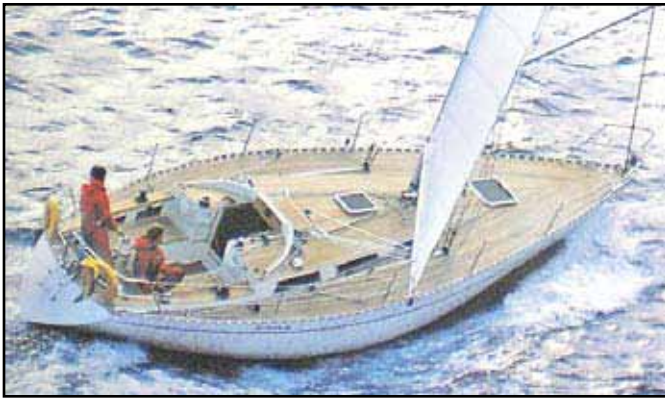

Move up to the beauty of a Sweden Yachts classic 1984 Sweden 36

Superb sailing characteristics, comfortable teak interior and quality construction combine to make this an exceptional find for the discerning West Coast sailor.

- Teak Decks
- Beautiful Interior
- Comfortable Cockpit
- Lots of Storage
- Lines Lead Aft
- Private Sleeping

Call for appointment
Asking \$75,000

Arriving Mid-October
NEW HANSE 350



Hanse 350

After unprecedented success with her introduction in Europe, the stunning, new Hanse 350 is ready to impress sailors on American shores.

See it at the Annapolis show or call for West Coast viewing!

LRM Larry Mayne Yacht & Ship
Northern California Hanse Dealer
General Manager, New Boat Sales, ABC Yachts
(650) 888-2324 • www.hanseyachts.net



RICHARDSON BAY MARINA
formerly Kappas Marina

MODERN FACILITIES IN A WELL-PROTECTED HARBOR

Concrete Dock System

Well Maintained Facilities

Beautiful Surroundings

- DEEP WATER BERTHS: BASIN AND CHANNEL DREDGED
- CARD KEY SECURITY SYSTEM
- DOCK CARTS
- PUMP OUT STATION
- AMPLE PARKING
- CLEAN SHOWER AND TOILET FACILITIES
- WITHIN WALKING DISTANCE: MARKET/DELI, LAUNDROMAT, RESTAURANT
- AT EACH BERTH: LARGE STORAGE BOX, METERED ELECTRICITY, PHONE HOOKUPS, WATER

BERTH YOUR BOAT IN SAUSALITO

Phone 415 • 332 • 5510

100 Gate Six Road, Sausalito • Fax (415) 332-5812

Self-Steering and Emergency Rudders

Don't leave port without'm!



MONITOR WINDVANE™

Servo Pendulum with optional emergency rudder
BEST FOR MOST BOATS

FREE DVD

See us at the Annapolis Boat Show

auto-helm
windvane

Auxiliary Rudder/Trimtab

NO LINES – EMERGENCY RUDDER PERFECT FOR DAVITS

Say's Rig

Pendulum trimtab on main rudder

FOR HYDRAULIC STEERING/HIGH FREEBOARD

SOS Emergency Rudder

BREAKS DOWN AND STOWS UNDER DECK

VISIT OUR UPDATED WEBSITE
3,000 BOATS AND MORE THAN 5,000 PHOTOS (added daily)

www.selfsteer.com

FACTORY DIRECT
SCANMAR
INTERNATIONAL

432 South 1st St. • Pt. Richmond, CA 94804
Tel: 510 215-2010 • Fax: 510 215-5005
Toll Free: 888-WINDVANE (946-3826)
email: scanmar@selfsteer.com

Not Using Your Boat?



**STORE
IT**

Want To Sell Your Boat?



**STORE
IT**

Want to Dry Out Your Boat?



**STORE
IT**

Leaving the Country?



**STORE
IT**

Want to Save Money?



**STORE
IT**

**DRY STORAGE
\$3.75/ft
Power & Sail**



CELEBRATING OUR 50TH ANNIVERSARY

NAPA VALLEY MARINA

1200 Milton Road • Napa, CA 94559

(707) 252-8011 • Fax (707) 252-0851

www.napavalleymarina.com

Marina • Boatyard • Chandlery • Brokerage

Dealers for
YANMAR

Interlux
yachtpaint.com

Distributors for *Brownell*
Boat Stands

LETTERS

and knew that *I.E.* had been well behind us days earlier. That they had made enough ground on us by day six to show up on the horizon did not sit well with us. In fact, their appearance caused our collective testosterone levels to skyrocket like the cholesterol count after a Big Mac junky. Well, the 'T'



COURTESY RECIDIVIST

The irrepressible 'Inspired Environments' ahead of 'Recidivist' once again.

levels didn't rise in Holly cuz she's a girl, and they just don't get that kind of stuff.

That *I.E.* intruded on our patch of ocean could only mean one thing — battle stations! It was a crystal clear day with blue skies, a nice 10-knot easterly breeze, and calm seas — just like in

the movies. We proceeded to bend on our war sail — a 120% delivery genoa — and hove to like sharks awaiting prey. They soon arrived, and we agreed over the VHF that this part of the ocean was too small for the both of us, and that there could only be one top dog. So at the sound of the horn, we were off!

It was obvious from the get-go that the testosterone of their crew didn't match the amount that was pulsing through our bodies. Maybe it was because they were older, or the fact that they also had a girl onboard. However, there's no such thing as an excuse at sea, so we soon left them in our wake. Some 1,200 miles from land and there we were, frantically working all our sail trim controls to squeeze every tenth of a knot out of the boat that we could. And that was that.

Until the next day, anyway. We thought they were well beyond the horizon behind us as *I.E.* was not in sight. They were ahead of us! What the &%#@! Without hesitation we went to full sail again, for we only had one goal that day — to rip their living guts out and use them to grease the treads of our tanks! (I've got to stop watching Patton re-runs!)

We soon began to gain on them, but this time we'd have a surprise in store. We would resort to the most childish thing that I could think of, a carefully orchestrated and choreographed full mooning! As we approached, we three 'boys' on board — Holly would agree with the term 'boys' — stood at attention with our backs turned. Then Holly gave the commands: "Ready!" We dropped our pants. "Aim." We wiped our bums with rolls of TP. "Fire!" We then turned and threw the rolls of TP at the *I.E.* crew, one of the rolls scoring a direct hit by landing in their cockpit!

(By the way, be careful when trying stuff like this at home. You see, when your passing speed is only .2 knot, you're not likely to get away fast enough before some amount of 'adult' embarrassment creeps in while your pants are still down. Besides, they were armed with cameras, and we didn't want to be immortalized on the Internet.)

But ours was a happy crew, for we'd surely done them a fatal blow. Surely they would be too humiliated to continue our race to San Francisco.

The next night we turned the corner of the Pacific High, and started racing along 39N toward San Francisco. Then a front came through with a northeast blow that pushed us south. The skies turned cloudy and there was an unending drizzle. This new breeze had surely separated *I.E.* and us for good, I

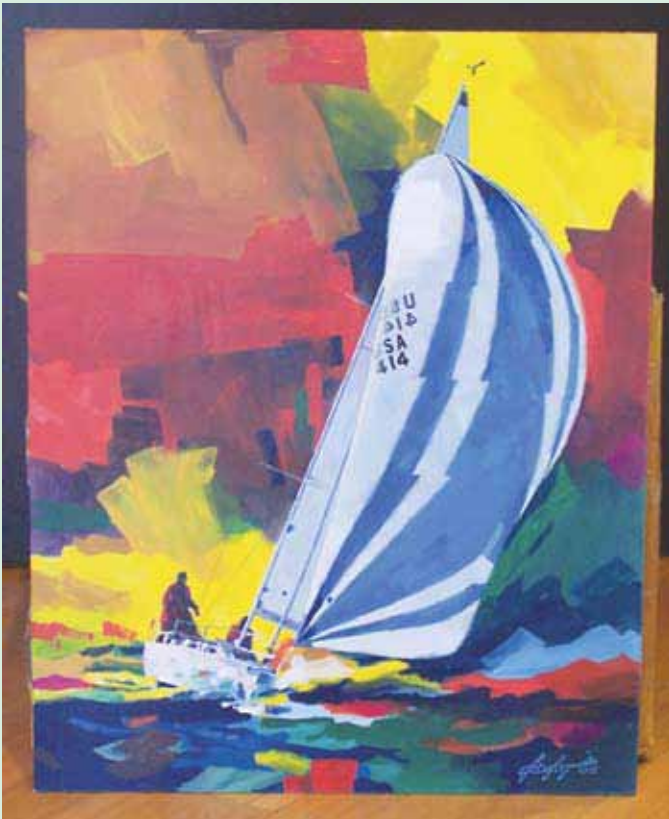

deWitt

Holiday Gallery Reception

Thursday, November 29
6:00-9:00 pm

DeWitt Art Gallery & Framing
121 Park Place, Point Richmond, CA 94801

(510) 236-1401

(800) 758-4291

www.jimdewitt.com

Tuesday-Thursday 10:00 a.m. to 5:00 p.m.
Friday 10:00 a.m. to 3:00 p.m.
Saturday Noon to 5:00 p.m.

Have Jim deWitt paint your boat racing in Big Boat Series! Commission early for the holidays!



Survive Your Dream



Courtesy Jimmy Cornell

'Great Atlantic Gear Test' Again rated #1!



Hydrovane is both:

- ★ Self Steering
- ★ BEST Emergency Steering

Announcing New Product!

ECH₂O Tec Watermakers

It Just Works – ALWAYS!

www.hydrovane-watermakers.com

604-925-2660 info@hydrovane.com www.hydrovane.com



Got Shade?

- Ingenious, self-supporting awning system, attaches to lifelines
- Tall enough to walk under at cabin, no limbo
- Bombproof construction, easily sustains 25 knots
- Sets up in 10 minutes, stows complete in its own 10" x 36" bag
- 10 standard sizes fit any boat, catamarans too
- Prices from \$300.00 to \$700.00

Visit: www.intheshd.com

ShadeTree
888-684-3743
shadetree@gulftel.com

shadetree 
Relax Under A ShadeTree



OYSTER POINT MARINA/PARK

MARINA SERVICES

BERTHING: 600 berths from 26-60 ft.

GUEST DOCK & BERTHING: Available at 60¢/ft./night

RESTROOMS & HOT SHOWERS: Public restrooms and private restrooms with showers

LAUNCH RAMP: Two-lane concrete ramp with parking for 70 boat trailers and cars

PUMP-OUT FACILITY: Located on the fuel dock

PARK/OPEN SPACE: Approximately 33 acres of park and open space with trails, promenades and swimming beach

FISHING PIER: A 300' concrete fishing pier

24-HOUR SECURITY

DRY STORAGE

CABLE TV: Available

OFFICE HOURS: Weekdays 8:30 to 4:30

Saturdays and Sundays by Appointment
Closed holidays

BOAT & MOTOR MART

New Boat Sales (Parker, Osprey)

Yacht Broker

(650) 246-1460

OYSTER POINT BAIT, TACKLE & DELI

(650) 589-3474

MARINE CENTER

Dry Storage, Fuel (Both Regular & Diesel)

(650) 872-0795

DOMINIC'S RESTAURANT

Weekday Lunch • Banquet Facilities

Dinner Nightly

(650) 589-1641

INN AT OYSTER POINT

Bed & Breakfast with Restaurant

(650) 737-7633

ANCHOR DETAILING

Complete Yacht Detailing Services

(650) 579-2776

OYSTER POINT YACHT CLUB

(650) 873-5166

Located in

SOUTH SAN FRANCISCO

Take Hwy. 101 to South San Francisco/Oyster Point Blvd. exit.

Then one mile EAST on Oyster Point Blvd.

By Water: 8.2 Nautical Miles SOUTH of Bay Bridge.

FOR INFORMATION CALL
(650) 952-0808
www.smharbor.com

LETTERS

thought to myself. We stayed with the squally northeasterly for hours until I finally blew the whistle. I awoke the crew with the shouted order: "We need to remove the preventer and go to the #3 jib." As I gave the order, a running light appeared to starboard. "Who could that be?" I wondered." Holly identified the vessel via VHF, and we found out that it was indeed our archrival, the dreaded *I.E.*!

Once the deck-side stuff was done, we came up to a fast close reach, making 8 to 10 knots. *I.E.* soon faded into the



COURTESY RECIDIVIST

Having run out of toilet paper the 'Recidivist' crew resorted to tortilla-flinging.

pitch black drizzle of the a.m. However, late that afternoon we spotted them again, off the starboard quarter and to the south! That was it — I couldn't take it anymore! Didn't they have the sense to quit?

But what could we do this time to humiliate them even further? We pondered the question for awhile, coming up with all sorts of crazy and disgusting foolishness. "Bed sheets. We'll make togas from bed sheets and wear crowns made from aluminum foil!" I decided. Then Gabe asked, "What about ammo?" "How 'bout these tortillas?" I suggested. Of course! Perfecto! And thus were born the 'Toga Tortilla Warriors'. It sounds pretty funny when pronounced with a thick Spanish accent.

Once we got into our togas and aluminum helmets, and prepared our ammo, we gybed twice and approached from the 'Master and Commander firing position'. "Prepare for a broadside," I said over the VHF, giving our enemy fair warning. Holly drove the boat alone on deck until we got to within tortilla range. Once alongside, the rest of us marched up the companionway ladder, danced around a few times shouting "Toga! Toga! Toga! Praise be to those who will soon die for Caesar," followed by "Sparta!" Yes, I know, wrong history. Nevertheless, the 'Toga Tortilla Warriors' then launched a massive flying Costco tortilla attack on *I.E.*'s crew. Unfortunately, all the tortillas fell into the drink just shy of their intended target. They don't make tortillas like they used to.

Although we pulled away from *I.E.* yet again thinking it was finally for good, it wasn't. Just three days out of San Francisco, we learned they were to the north of us and in the lead! But like I said, there's no such thing as giving up at sea, so the next day we turned in 188 reaching miles and got back in the lead. We passed beneath the Gate some 30 miles ahead of *I.E.* Victory never tasted so sweet!

Oahu to San Francisco in 15 days, 19 hours. But it seemed so much quicker than that!

Arnstein Mustad, Delivery Skipper
Northern California

Arnstein — In a world that's become so serious and sensible, thank god there are still the likes of you.

LOTS OF DYLAN AND CLAPTON ON ROSITA

Firing on all cylinders! September's issue looked, smelled, and read like pastrami from a New York deli — not something thrown together at a truck stop. From the *Letters* that included



MODERN SAILING ACADEMY

SAUSALITO, CA

PREPARE TO TAKE THE HELM



www.MODERNSAILING.com (800-995-1668) or (415-331-8250)

ADVENTURE SAILING with JOHN CONNOLLY

Check our website for future trips.

Caribbean 2007 \$1975 person, \$3555 cabin
 Leg 1: Dec 11 - Dec 21 *St. Lucia to Grenada*
 Leg 2: Dec 24 - Jan 3 *Grenada to St. Lucia*

Considering a Club Membership?

Become a member! Enjoy club events, BBQs, club sails and great deals on chartering - up to 40% off!

Monthly Dues Only \$35!

Heavy Weather Offshore Course.....Oct 29 - Nov 4

This ASA Advanced Coastal Cruising course sails to Monterey Bay and back to SF. Wind Vane, Radar and many cruising functions are taught by John Connolly, ASA Ocean Passage Instructor, 100 ton USCG, and RYA Oceans Instructor.

Basic Keelboat	} We have added dates and times to accommodate demand!
Basic Coastal	
Combo (BKB & BCC).....	
Bareboat Course.....	
Catamaran Course.....	
Advanced Coastal Course	

Club Sail (10am - 4pm) and BBQ on Oct 13

This is the perfect opportunity to tour the club, meet our members and staff and spend the day sailing. **FREE BBQ afterwards!**



Captain's License Course - U.S. Coast Guard Approved

We are the ONLY sailing school on San Francisco Bay that offers these courses with **On Site Testing and On-The-Water Practical. Our pass rate is 100%. We Guarantee it.** Convenient night and weekend classes make it ideal for all.



(Nov. 3 - Dec. 9, 2007) OUPV (6 pack) - \$895 100 Ton Master - \$1095

less fuel
less noise
less pollution
more power



OSSA Powerlite diesel-electric systems by Glacier Bay are up to 95% quieter.
www.ossapowerlite.com

Glacier Bay, Inc. 2930 Faber Street Union City, CA 94587
(510) 437-9100 (510) 437-9200 fax www.glacierbay.com

COVER CRAFT

The Bay Area's Finest Canvas Dodgers

Biminis, Covers, Enclosures



Better materials, better workmanship

Our Customers Say It Best:

"The quality is such that it can only be described as a work of art."

1230 Brickyard Cove Road, #106
Pt. Richmond, CA 94801
In Brickyard Cove Marina

(510) 234-4400

Quality
Yacht
Canvas

Your boat deserves the Seashine touch



PREMIUM QUALITY BOAT CLEANING
AND MAINTENANCE

Polishing • Detailing • Maintenance
Bilge Cleaning • Washdown
Carpet and Cushion Cleaning

SERVING THE BAY AREA SINCE 1986

Contact us today for a free estimate

510 428-2522 • 415 457-6300 • www.seashine.net

➤ AMERICA'S CUP, VOLVO OCEAN RACE,
VENDÉE GLOBE, TRANSAT 6.5M...

THEY CHOOSE KARVER ... AND YOU?

Euro Marine Trading Inc.
Toll Free: 800-222-7712
Email: info@euromarinetrading.com
www.euromarinetrading.com



www.karver-systems.com

LETTERS

both sides of the Barefoot Charter controversy, to the *Spending Too Much* article, to the Mel and Will Peterson interview, to the good Puddle Jump recap, to the *Changes*, it was a great issue. If somebody didn't get one, they should heed the words in the song by Eric Clapton "Please don't mess with mine."

Speaking of the Barefoot Charter matter, I must chime in on the side of the owner of *Birdwing* — only because Barefoot's response seemed to continuously dodge the issue of responsibility. In my business, which is transportation, those issues are clearly defined in the contract. Once Barefoot took possession of *Birdwing* and her possessions, it seems to me that they had a duty to take care of them. If Barefoot "cannot take responsibility," then it is clear that Barefoot shouldn't have taken possession. They could have told the owner of *Birdwing* to make other arrangements.

As for damage to pulpit stanchions, it should have been reported to the owner of *Birdwing* as soon as the damage occurred — with pictures and an explanation of why Barefoot felt it had been an "act of God." By the way, I took it upon myself to email a copy of that letter on to God, and asked if he/she would admit that it had been caused by one of his/her acts. No response just yet.

As for *Latitude's* Safe Boating Challenge to Lake County Deputy Sheriff Russell Perdock and D.A. Jon Hopkins, it was right on the mark. Any reader who has been outraged by the senseless death of Lynn Thornton and then the cover-up to protect Deputy Perdock from criminal prosecution, and who has not written, emailed, and screamed from the highest tower about it, should, as Bob Dylan sang, "You who philosophize disgrace, and criticize all hate, hang your head at your side, for now is the time for your tears."

Thanks for a great job, *Latitude*.

Jerry Metheany
Rosita, Hunter 46
Mazatlan

Jerry — It takes a big man to give such compliments — since that issue also had a response to a letter of yours that wasn't particularly flattering. A tip of the Latitude cap.

And now, in a continuation of your '60s music theme, how about a little Leon Russell and "Back To The Island," the song that starts and ends with the sounds of waves breaking on the beach and monkeys talking it up in the jungle.

↑↓ WE LIKE TO WORK WITH OUR YACHT OWNERS

We see that the exchange of letters between the owner of *Birdwing* and us has been published in the September issue, and I'd like to respond to your editorial comment, "The things that strike us as most odd about the *Birdwing* situation are: 1) That *Birdwing* was allowed into the Barefoot program sight unseen. After all, she was eight years old at the time, had seen considerable use as a private yacht, and had all kinds of non-charter gear aboard — three big red flags. And why Barefoot would keep a 'problem yacht' in their program for years is as perplexing as Pastore leaving his boat in a program he wasn't satisfied with."

1) Barefoot Yacht Charters is primarily a 'second-tier' company, meaning that the majority of yachts that join our fleet are anything from four to eight years old. It is not at all unusual for second-tier companies to accept older yachts into the fleet, and is something that we've been doing for the past 23 years that we've been in business. So for an operation such as ours, this was not at all a red flag.

2) We were never aware of what you refer to as "considerable use as a private yacht," and are not sure where you get this

Catalina//Yachts

Get out on the water.
(Not in over your head.)

**Business
Opportunities
Available in
Bay Area**

**Introducing fractional sailing
from WindPath.**

Sail a new Catalina luxury yacht in your local waterways without maintenance hassles — for less than you ever imagined. Evening sails, day sails, even week-long sailing trips — just choose when you want to sail: We do the rest. WindPath offers Fractional Member and Member Owner programs, (including sail training!) in a marina near you.



Always leave the dock happy.

Visit us at www.WindPath.com or call 888.2.WindPath

©2006 WindPath Sailing, Inc. L38906

**Buy
Quality
Sails
Direct
at 25-40%
Savings!**



It's the easy way to measure and order your own sails and SAVE!

www.cruisingdirect.com
FREE 2006 BUYER'S GUIDE call toll free:
1-888-424-7328, or fax: 1-888-237-2457



MANUFACTURED AND SERVICED BY NORTH SAILS

KISSINGER CANVAS

Marine Canvas & Interiors
STEVEN KISSINGER
(925) 825-6734
Covering the Entire Bay Area



- Biminis
- Boat Covers
- Cushions
- Sail Covers
- Headliners
- Awnings

DODGERS

Side handrails and window covers
included

OPTIONS

Aft handrail, dodger cover,
sailing bimini.

Free Estimates and Delivery

Blue Water Yacht Insurance

Blue Water Yacht Insurance covers more active cruising boats than any other marina agency in the Western Hemisphere and is the leading innovator of insurance products for the offshore sailor.

Our Insurance Programs Provide

Crew of two Anywhere	World Wide Navigation
Hawaii	Europe
South Pacific	Caribbean

Low Local Coastal Rates

Local Coastal USA • Hawaii

Blue Water World Wide Health Insurance

International and USA health insurance plans at affordable prices.

West Coast Office

2726 Shelter Island Dr.
PMB 3892726
San Diego, CA 92106

East Coast Office

1016 Clemons St., Ste 404
Jupiter, FL 33477



Call Toll Free: **(800) 655-9224**

Fax: (866) 795-3707
email: sales@bluewaterins.com

Visit our web site:
www.BlueWaterIns.com



LETTERS

from. What we knew was that Mr. Pastore had purchased the yacht relatively recently and, according to him, had spent a great deal of money on her. It was therefore very reasonable for us to assume that he would not have bought the yacht or expended large sums of money on her unless he had been satisfied that the yacht was in excellent condition. Further, had she been in prior private use, then it would also be reasonable to assume that she had received considerably less use than a yacht that had previously been in bareboat service. And since 99% of the pre-owned yachts that join our fleet have been in bareboat service prior to joining us, one might therefore also reasonably assume that she would have been in better shape than any of those former bareboats. Further, we were not aware of the extraordinary amount of equipment that she had on board until she physically arrived here.

3) Over the years, we, as a small company, have developed very personal relationships with our yacht owners. Many have become friends. Because of the nature of these relationships, it is never palatable to us to kick a yacht out of our fleet without first trying to work with the owner to resolve any problem areas. The 'big players' in the industry will do this, but it's not something that we like to do. Recently, we gently suggested to the owner of a 17-year-old bareboat in our fleet, as well as two other yachts of 11 and 13 years, that he place the yacht on a caretaking basis rather than have her continue in charter service. We didn't want him to suffer financially from the increasing wear and tear of bareboat charters and the increasing difficulties we were facing in operating her as a result of a lack of revenue. He accepted our offer and withdrew the boat from charter. Perhaps we're being too nice and should have kicked these yachts out years ago. But as I say, we prefer to work with our yacht owners rather than to simply dump them when we feel that the benefits to ourselves have been exhausted.

More importantly, however, in this particular instance, we did ask Mr. Pastore to remove his yacht from our fleet, but he asked that we retain her as his circumstances did not allow him to take possession of her. Against our better judgement, we did so. Hindsight, of course, is always 20-20.

On a lighter note, please note that my first name is Narendra and my surname is Sethia, so I'm Narendra Sethia, not Seth Narendra.

Narendra Sethia

Barefoot Yacht Charters & Marine Centre
Blue Lagoon, St Vincent & The Grenadines

Narendra — *Our apologies for blundering your name. Now that both sides have spoken their peace on this issue, we're going to close it, assuming that our readers are now fully aware of the types of problems that can possibly arise between the owners of boats in yacht management programs and the yacht management companies. By the way, we're not suggesting this is by any means typical of relationships, as most people we know with boats in such programs have been reasonably happy to quite happy with them.*

In a typical month, we receive a tremendous volume of letters. So if yours hasn't appeared, don't give up hope.

We welcome all letters that are of interest to sailors. Please include your name, your boat's name, hailing port, and, if possible, a way to contact you for clarifications.

By far the best way to send letters is to email them to richard@latitude38.com. You can also mail them to 15 Locust, Mill Valley, CA, 94941, or fax them to (415) 383-5816.

DIMEN

Marine Financial Services

"A better way to get a boat loan."

Boat Loans



Loans Starting
at \$25,000

Fixed Rates

New and Used

Liveaboard

Northern California

Bill Kinstler

866-486-2628

dimenmarine@pacbell.net



Tradewinds Sailing School and Club

1230 Brickyard Cove Rd #100, Point Richmond, CA 94801

Phone: (510) 232 - 7999

Email: staff@tradewindssailing.com

“The Best Sailing and Training Value on the San Francisco Bay!”

American Sailing Association School

Basic Keelboat (101) - \$525

October 6th
October 10th
October 20th
October 22nd
November 3rd
November 10th

Basic Coastal Cruising (103) - \$675

October 6th
October 20th
October 29th
November 3rd
November 10th

Bareboat Charter (104) - \$895

October 6th
October 13th

***Dates listed are class start dates. 101 and 103: Weekend classes are 4 days. Weekday classes are 3 days. 104: Class is 2 consecutive days with overnight.*

Our club members enjoy unlimited sailing for one low monthly rate!

Winter Special!
Take \$200 off any of the above courses!

www.TradewindsSailing.com



FULL SERVICE PROPELLER AND SHAFT REPAIR

Bay Propeller is the largest and most experienced propeller shop in Northern California

**SAIL MORE
SAIL FASTER
SAVE FUEL**



Folding or feathering props simply make your sailing life better.

Call NOW to SAVE up to 15% on:

Gori • Flex-O-Fold • Martec and more!

BAY PROPELLER • 2900 MAIN STREET #2100 • ALAMEDA, CA 94501

510-337-9122

FAX: 510-263-9827 • www.bay-ship.com

SEA FROST®



COOL IT YOURSELF!

Refrigeration has never been easier. Sea Frost's compact and powerful, 12-volt BD refrigeration conversion kit comes pre-charged and ready for owner installation.

Sea Frost...Quality at an affordable price!

Local Dealers:

Anderson Refrigeration Co. • Alameda, CA
(510) 521-3111

Poole Refrigeration Service • Alameda, CA
(510) 523-3495

www.seafrost.com



greenboatstuff.com

Environmentally Friendly Boating Supplies

- Anti-Fouling Paint
- Fueling Systems
- Sunscreen
- Galley Gear
- Clothing & Linens
- Personal Care Items
- Bags & Buckets
- And Much, Much More!
- Cleaning Supplies

VISIT OUR WEBSITE TODAY!!

www.greenboatstuff.com



LOOSE LIPS

Eight bells.

Susan Wosser Madrigali passed away from heart failure while walking her dog in Tiburon on September 8. She was 59.



COURTESY ANNA DESENBERG

1987 Adams Cup Area G crew (l to r): Anna Desenberg, Susie Madrigali, Jan Critchley and Stephanie Wondolleck.

As a young girl Susie began racing with her father, the venerable Jake Wosser, aboard his International One Design and K-40. After spending several years skiing across Europe, she settled down back in Marin and got serious about racing sailboats.

Susie was at the top of her game in the 1980s winning most of the women's races on San Francisco Bay (a time when there was a very active women's racing association). She qualified for the Adams Cup (US Sailing's Woman's National Championship) many times, and her greatest victories were placing 2nd overall in Solings in San Francisco and 3rd in J/24s in Miami. In addition to Bay racing, Susie made several ocean voyages across the Pacific and to Mexico. Win or lose, Susie was a great competitor, good humored, fun loving and full of zest.

Susie is survived by her children Matt Madrigali of San Rafael and Amy Madrigali of Seattle, and her mother Ruth Wosser of Tiburon. A memorial is also planned for October 12 at SFYC at 5 p.m. Her ashes will be scattered at a later date. Charitable contributions may be made to the Belvedere Cove Foundation, P.O. Box 786, Belvedere, CA 94920.

— anna desenberg

Steve Fossett missing.

As we went to press, the search for adventurer Steve Fossett was into its third week in the skies over western Nevada. The record setting sailor, balloonist and pilot took off in a small, single-engine airplane on September 3 and has not been seen or heard from since. The resulting search is one of the largest, longest, most extensive and possibly most expensive searches of this area ever. In addition to Civil Air Patrol, Army and Air National Guard units, up to a dozen private aircraft a day (and night, using infrared and other spectrum analysis techniques) have taken to the air in search of any sign of the 63-year-old adventurer or his blue-and-white Bellanca Citabria Super Decathalon airplane. The civilian end of the search is headquartered at Barron Hilton's Flying M Ranch near Minden, which is where Fossett took off. So far, upwards of 17,000 square miles of mostly barren desert have been searched — an area one article likened to 'the Bermuda Triangle of flying' for the more than 50 aircraft which are thought to have gone down there over the years. Indeed, searchers have located many old wrecks, at least one of which occurred in the early '60s and had never been found until now.

As with sailor/technologist Jim Gray, who disappeared during a singlehanded sail to the Farallones earlier this year, the search for Fossett has also expanded to the Internet, where even you

PLEASE JOIN US FOR THE
TALL SHIP EDUCATION ACADEMY'S 9TH ANNUAL BENEFIT RECEPTION

RED WINE & RUBBER BOOTS

TALL SHIP EDUCATION ACADEMY
invites you to join us for:
October 14, 2007
THE WOMEN SKIPPERS REGATTA
hosted by the Sausalito Yacht Club Auxiliary

AND
October 18, 2007
RED WINE & RUBBER BOOTS
Board the historic ferry boat Eureka at Hyde Street Pier and celebrate the graduates of our tall ship programs. Rubber Boots optional!

Tall Ship Education Academy offers life skills training through accredited experiential education sailing programs for Bay Area high school girls.

For more information and to purchase tickets, visit
www.tallshipacademy.org



TALL SHIP EDUCATION ACADEMY   **SAN FRANCISCO STATE UNIVERSITY**
TSEA is a special project of the Recreation & Leisure Studies Department

Photo: David Gartland



Early Winter Specials! Call Now!

Racing? Cruising? Day sailor? From anchor light to keelson, we've got you covered!

- **Engine sales and installation**
- *Sprayed racing bottoms*
- *Custom topside paint*
- *Fiberglass and gel coat repairs*
- *Electrical and mechanical systems*
- *Rigging repairs and refit*
- *Wood repairs*

SAN FRANCISCO BOAT WORKS

835 Terry A. François St., San Francisco, CA 94158
(415) 626-3275 Fax (415) 626-9172

WE'RE HIRING - SEE CLASSY CLASSIFIEDS P. 222

www.sfboatworks.com
sfboatworks@yahoo.com



frigoboat®

Keel Cooling System

- No Pump
- No Fan
- No Noise



Arguably the world's most efficient, dependable refrigeration. The keel cooler and super efficient compressor make for a quiet, highly efficient 12V refrigeration system.



SWEDISH MARINE

1150 BRICKYARD COVE RD., SUITE B6
PT. RICHMOND, CA 94801 (510) 234-9566

GLEN COVE MARINA

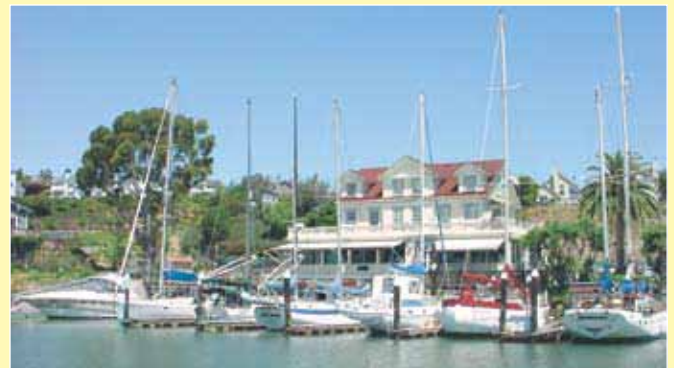

Located on the Carquinez Straits

- 135-ft. Guest Dock
- Yacht Clubs Welcome
- Café & General Store
- Picnic & Event Areas
- Great Fishing Spots Nearby
- Free Wireless Internet
- Pump Out
- Security
- Showers & Laundry

Now Available:

24-36 ft. Covered Berths • Up to 55 ft. Uncovered Berths

GLEN COVE MARINA 707-552-3236

2000 Glen Cove Road, Vallejo, CA 94591

www.glencovemarina.net • glencovemarina@gmail.com

SEE THE FUTURE: Forward Looking Sonar

SE-200

Now plugs into your
multi-function system
or VGA display



The SE-200 does below the waterline
what radar does above. Take a look ahead.

www.interphase-tech.com
888.777.6627

INTERPHASE
Forward Looking Technology

ALWAYS
THINK
AHEAD™



LOOSE LIPS

might be able to help find him. Log onto www.stevefossett.com for instructions on how to search various grids on Google Earth using Amazon.com's 'Mechanical Turk' tool.

Fossett made a fortune in commodities trading. For the last 15-20 years, he has relentlessly pursued 'personal best' goals, many of which have resulted in world records in sailing, flying, soaring and ballooning. He didn't do it for the glory or the press (he actually shunned that for the most part), but in the best traditions of George Mallory: "because it was there."

With his 125-ft catamaran *PlayStation/Cheyenne*, he at one time set all the big sailing records, including the Trans-Atlantic, 24-hour run and round-the-world. (All have since been broken, although he still holds several other sailing records.) He also holds many aviation records, including becoming the first to fly nonstop, unrefueled around the world, and the first nonstop balloon flight around the world. We certainly join his family, friends and supporters in hoping he will be found alive.

We couldn't make this stuff up if we tried.

German artist Frank Boelter was fooling around with a milk carton at breakfast one morning when all of a sudden (so the



Boelter's boat. Hey, it makes more sense than a lot of other so-called "art".

report goes) it occurred to him that you could build a boat out of this stuff. So he did. Using an 1,800-square-foot piece of Tetra-brik — a paper product which is used, among other things, for making milk cartons — Boelter spent just two hours bending and folding to come up with *Bis Ans Ende der Welt* ("Until the end of the world"), a 30-ft, 55-pound 'boat' that cost all of \$217. Boelter says the craft will survive a biblical 40 days and nights before it disintegrates into a soggy blob.

Just when you *again* thought it was safe . . .

It probably won't matter much to local sailors, but we thought you might be interested to know that Bolinas appears on a list of 10 *Dangerous Shark Beaches* — that is, the 10 places in the world where you are most likely to get chomped. Other U.S. beaches on the list included New Smyrna in Florida and Kahana, Maui. The rest were scattered from Brazil to Australia, with South Africa receiving the most mentions with three. The *most* dangerous place? Not noted, although we'd nominate Kosi Bay, South Africa, "where Zambezi sharks like to hunt for their food in fresh water lakes and rivers, making no body of water in this region safe." Terrific.

The list appeared in May in *Forbes Traveler*.



McGinnis Insurance

Since 1972

Knowledge ⚡ Commitment
Reliability ⚡ Service



Large and small, we do them all!

Call us at: **800-486-4008**
mcginnisins@aol.com

License #0570469

Wright Way designs

MARINE UPHOLSTERY & INTERIORS

PROFESSIONAL
DESIGN
SERVICES
INCLUDE
CUSTOM
carpeting
cushions
designer fabrics
draperies
linens
upholstery



NEW
AGENT FOR
BottomSiders

Deborah Wright
510.908.3939

2900 Main Street, #67, Alameda, CA 94501 • wwdesignz@hotmail.com

The difference between a boat and a yacht



- Mobile Service:
We Deliver!
- Washing
- Waxing
- Varnishing
- Interior Cleaning

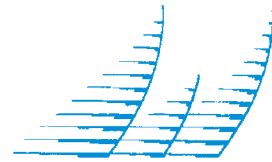

Westwind

Complete Yacht Care

Serving the entire Bay Area for
more than 20 years



(415) 661-2205

Pier 40, South Beach on the Embarcadero • San Francisco

Call Toll Free **888-828-6789**



westwinddetailing@sonic.net
www.boatdetailing.com



IT'S GOTTA BE
AWLGRIP

The world's finest boats and largest yachts demand it: a shine so lustrous, so deep – so unmistakably Awlgrip. When you finish with Awlgrip, you get a topcoating system that is as durable and consistent as it is beautiful. And with a full spectrum of colors, Awlgrip provides truly innovative solutions and unmatched global support, giving you help – and answers – wherever you go. When you want it all, it's gotta be Awlgrip. www.awlgrip.com

AWLGRIP

NORTH AMERICA 1 East Water Street Waukegan Illinois 60085 **TEL:** 847.599.6212 **FAX:** 847.599.6209

Awlgrip is a registered trademark of Akzo Nobel

SIGHTINGS

braah! braah! braah! braah! braah!

We all know that five sounds on the horn of a ship on the Bay usually means that a small vessel is in danger of being run over. Well, we're sounding five blasts of an imaginary horn to warn all local mariners that if we don't do a better job of staying out of the way of large commercial vessels in restricted fairways — which means almost all of the Bay and Delta — we could be jeopardizing our right to use those waters.

Up in the Delta a couple months ago, a sailboarder foolishly got

downwind in front of a big ship. Becalmed, he was helpless to get out of the way. To keep from running over the hapless sailboarder, the pilot/captain had to take extreme evasive action — and hit a navigation structure as a result.



CAPT. MORGAN HOBURG

You think seeing over your dodger is a pain? Just imagine peering over several hundred 40-ft containers.

During the Singlehanded Sailing Society's East Bay Estuary Race on September 8, a number of competitors were confused by the intentions of two Oakland and Estuary-bound ships, and/or didn't have their diesels/outboards at the ready in order to quickly get out of the way. It caused another major incident.

And if you spend much time on the Bay, you know that all too frequently captains and pilots have to resort to five blasts to warn some small boat mariner that he/she is in extreme danger.

Yes, we've heard more than a few small boat sailors say they really weren't in a ship's way. Often times they think that only because they didn't have the captain/pilot's 'big picture' view from 150 feet in the air, or because they weren't looking miles ahead as a captain/pilot must. In other cases, small boat mariners weren't prepared for the possibility that the ship was going to be making a 90-degree turn.

It's easy to stay out of the way of ships. First, know where the main shipping lanes are. Second, unless you're a very good sailor and there's a good breeze, don't dally in the main lanes. Third, anticipate where ships are going and where they might be making sharp turns. Fourth, get way the hell out of the way of ships! Sailing parallel to a ship 150 feet off her port or starboard beam just isn't going to cut it, because four or five other fools might be doing the same reckless thing further up, limiting the captain/pilot's ability to navigate safely. If you see a ship coming toward you, sail perpendicular to its course, giving it a wide open path. It's virtually no trouble to you, the small boat mariner, and collectively it could help prevent the rest of us from losing our rights to use all of the Bay and Delta waters.

As for racers, we understand, you've made a big effort, you're in a competitive situation, and you don't want to be blocked. But you've got to stay clear — or else run the risk of many races being restricted to waters where ships can't go. If you plan well in advance, your encounters with ships will only cost you seconds rather than minutes, and we'll all be able to continue sailing in the best parts of the Bay.

— richard

it's not the evil eye

If you're one of the many folks sailing to Mexico this winter, you need to be aware of a potentially painful creature of the sea that's not so prevalent on California beaches. We're referring to the stingray, one eye of which you see in the photo on the next page, taken by the folks on the schooner *Coco Kai*.

You may wonder how they can see what they're eating when their eyes are on top of their bodies and their mouths are on the bottom. The answer is they can't. They use electroreceptors, just like Mr. Shark, to find mollusks and crustaceans.



you have to fear

Although stingrays have very sharp, shell-crushing teeth, it's their sting, not their bite, that you have to worry about. Normally, they save their venom-secreting glandular tissue stinger, normally kept inside an integumentary sheath, for defense against sharks, their main predators.

However, if you step on one, they'll whip their razor sharp stinger into your foot. Anyone who has gotten nailed by a stingray barb will assure you that it hurts like hell, particularly for the first hour or two. The pain can be accompanied by nausea.

continued in middle column of next sightings page

mexico-only crew list

Excuse us while we serve a bit more crow to the doubting Thomases in the office, but it's hard to argue with results: our decision to move the Crew List online has been a big success. Not only has the Mexico-only Crew List taken off with owners and crew hooking up almost instantly, but all our other lists (which are normally dormant until spring) are also buzzing with activity. Just to rub it in, the 'believers' are now wondering out loud why we didn't make the move years ago.

If you're coming in late and going "Crew List? . . . what's that?," allow us to elaborate.

The Crew List has been a part of *Latitude 38* for more than 20 years. It was conceived for, and remains focused on, matching up boat owners who need crew with people who want to crew. The Mexico-only list

continued on outside column of next sightings page

'Daring' to say goodbye to summer. We've had an unusually warm summer on the Bay — we're sad to see it go.



SIGHTINGS

crew list — cont'd

— which is currently the most active — is for cruisers headed south of the border this fall. Our other lists, which have traditionally been most active in the spring, are specific to racing, cruising (worldwide), daysailing, co-chartering and boat-swapping. No matter what type of sailing you do or want to try, there's a crew list for you. And like *Latitude*, they are free as the wind.

Normally, the print version of the Mexico-Only Crew List appears in this, our October issue. Because of the immediacy of the Internet, we decided it should (and could) appear earlier, so we ran it last month instead. If you missed it, don't worry. Just go to www.latitude38.com and click 'Crew List' on the homepage. You will instantly be transported to the Crew List main page, where you can peruse basic

continued on outside column of next sightings page

evil eye

fatigue, headaches, fever and chills.

The common treatment is near-scalding water applied directly to the wound. Local anesthetics can help too. It's long been claimed that urine on the wound will help, but that's only because of its warmth, not because it denatures the venom protein. Unseasoned meat tenderizers might also provide a little relief.

You also need to make sure that all of the barb is removed, and that there is no infection in the hours and days later.

The thing to remember is that these



COURTESY COCO KAI

— cont'd

cute little guys don't *want* to sting you. In fact, if you just bump into them, they'll happily swim away. As such, the way to prevent getting stung is by always shuffling your feet when walking along flat sand shallows, particularly at remote beaches, where stingrays feel most comfortable.

We'll end with a quiz. What do you call a group of stingrays?

A fever — which is what you might get if you're not diligent in shuffling your feet.

— richard

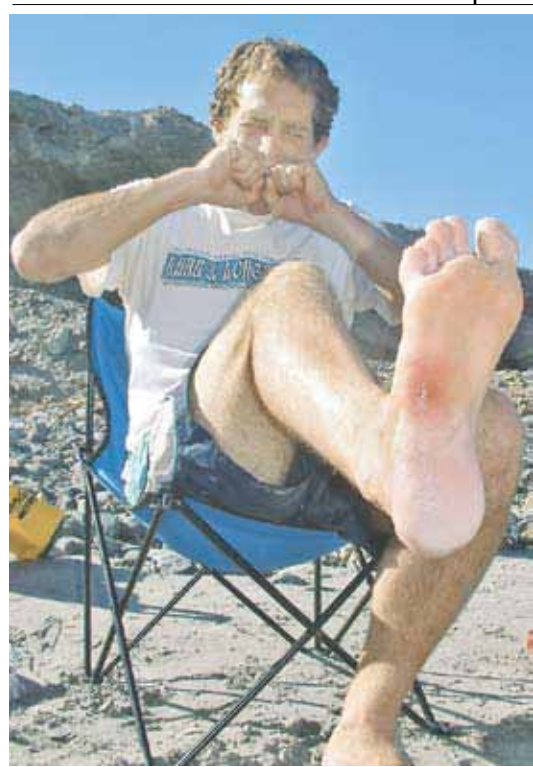

Beware the evil eye — Really, you need to beware the spiny tail of sting rays. Shuffle your feet or you may end up like Justin, who was crew on 'Jenny Wren' in the 2002 Baja Ha-Ha.

crew list — cont'd

instructions, as well as the most up-to-date 'real time' lists. One thing that threw us early in the process was the apparent dearth of boat owners looking for crew. But we soon realized what's really happening: boat owners were finding crew so quickly that some were there and gone in the virtual blink of an eye. For awhile, the turnover was so rapid that at any one time there were only six or eight skippers listed. Now the list has stabilized a bit at around 18-20 names.

What hasn't changed much are the Crew List parties. As always, these affairs are twice-yearly events for skippers and crew to meet and mingle, or just enjoy some refreshments and rub elbows with a bunch of like-minded people headed south. A few years ago, somebody got the idea of inviting past and present Baja Ha-Ha participants — and once again, why didn't we think of this sooner? Not only have several crew connections been made between the two factions, they also really complement each other in terms of shared knowledge. The parties also feature liferaft demonstrations, limited free munchies, no-host bar, T-shirt sales, a Ha-Ha digital slide show and an occasional surprise guest.

This year's Crew List and Baja Ha-Ha Party is at the Encinal YC in Oakland on Wednesday, October 3, from 6 to 9 p.m. Admission is \$7 for everyone *except* Ha-Ha skippers and first mates who are officially entered in Baja Ha-Ha XIV.

Good luck and good 'matchmaking' to all of you Mexico-bounders!

— jr

return of the 90-day yacht club

The 90-day rule is back. As of August 21, when the Senate finally approved the new state budget, you can avoid paying sales tax on a yacht (or airplane or RV) if you keep it out of the state for 90 days after purchase. This was such a common practice a decade or so ago that Marina Coral in Ensenada was nicknamed the '90-Day Yacht Club'. In 2004, the State Legislature put the kabash on the deal, rewriting the law so that you had to stay out of state for a whole year. Their thinking was that this would discourage the practice and swell the state coffers by about \$55 million. It apparently didn't occur to them that, with only a little more effort, those who bought high-dollar yachts or planes could form an offshore corporation to buy the boat — thereby also avoiding tax.

At any rate, the 90-day rule is back. For a refresher course on how it works, we contacted Captain Lonnie Ryan, author of *The 90 Day Yacht Club Guide to Ensenada*. If anyone would know what was happening, it would be him. So here, as well as he or we understand it, are the high points of the law as it now stands:

It used to be that you had to physically perform the transfer of ownership by following your boat-to-be out to the three-mile limit in a chase boat. Once legally out of state waters, you had to transfer to the yacht where you and the owner or owner's representative (such as a broker) would exchange a check or bank draft for title documents. The owner or rep would then board the chase boat for the ride home, while you took your new yacht north or south to another state or country. To prove you actually did it, all this had to be chronicled on film and overseen by sworn witnesses who would sign affidavits for later scrutiny by state officials.

Currently the law is less stringent. Now you can ride out and back aboard the yacht with the old owner or broker. Then, after completing the transfer, you are now allowed to come back to your California port and spend up to 89 days readying the boat and yourself to leave the state for the prescribed period. As to *that*, the '90-Day Yacht Club' is a bit of a misnomer. Since you must spend a *full* 90 days offshore — and why push the issue? — to be perfectly accurate, it might better

continued on outside column of next sightings page

SIGHTINGS

90 day yc — cont'd

be called the 91-day rule.

As in the past, it remains of utmost importance to chronicle everything. Luckily, current technology such as camera phones, digital cameras and camcorders, and GPS make this easier than ever: break out the camcorder and film the GPS as soon as it verifies you are outside the 3-mile limit. Keep filming or snapping (make sure the camera's internal time and date settings are accurate) as you exchange the money and ship's papers, while everyone signs an 'affidavit of delivery' with the lat/lon noted, and even when you shake hands to complete the deal. (If you're working through a broker, he/she will bring all the necessary paperwork.)

One often-overlooked aspect of the transfer is that you need to insure your new yacht at the time of the sale. Again, technology to the rescue: use your cellphone to call your insurance broker to get your insurance going *after* the transfer is completed. The date and time he puts on the binder will be viewed later as critical proof of when the transfer of ownership at sea occurred.

Be aware that all your ownership paperwork must be complete before you can legally do anything with the boat, such as navigate it, sail it, fish from it or pay slip fees for it, either in California or Mexico. Also be advised that 'cutting corners' on any of this could result in you having to pay the tax at some later date.

Now for the difference between tax avoidance and tax compliance. In the eyes of the law, if you purchase a yacht offshore, keep it in a Mexican marina for three months and then bring it back, this could be interpreted as tax avoidance — and you could be charged tax. To be tax compliant, you must *use* the yacht while it's offshore — stay on it, sail it, party on it . . . and again, keep exhaustive video, digital and paper records. Save receipts for everything from fuel to flights to fajitas.

Within 12 months of purchase, you will receive a bill from the state for the full amount of tax due. Everybody gets these whether they've taken possession offshore or at their local marina. Now is when you claim the 90-day exemption (via state form BOE-106) and submit all your proof. Just arrange all the papers, CDs, DVDs, photos and so on neatly in an envelope or binder and send it in. As with everything legal, it's best to send copies and keep the originals of everything you send. If you do everything properly and in order, you will not hear back from the tax man. If you don't, you will.

A few final words: be aware that the 'fine print' recognized by the State Board of Equalization changes now and then. Most yacht brokers these days are knowledgeable in the general aspects of the offshore delivery process, but if you really want to make sure everything will turn out correctly, you should consult a state-licensed maritime tax attorney. He or she should be able to guide you through the intricacies of the process as it's being applied at the time of sale.

— captain lonnie ryan and jr

Readers — For further updates and more information, visit Ryan's website: www.truetraveler.com.

seriously disgusting

We've all heard horror stories involving injuries and illness at sea — a hatch slams down and severs the tip of an unsuspecting finger; a husband has a heart attack at sea and his terrified wife has to skipper the boat into port; a wayward bee's sting sends a crewmember into anaphylactic shock — so we ready our medical kits to contain such important items as sutures, EpiPens and high-octane painkillers. Almost as an afterthought, we throw in a course or two of some general antibiotic, just in case.

As frightening and serious as the above situations can be, they're

continued on outside column of next sightings page

girls summer

This summer, a diverse group of girls from San Francisco, Oakland and Daly City enrolled in the Tall Ship Education Academy's Girls Summer at Sea program. They were looking for an adventure and



COURTESY TSEA

Girls from all over the Bay Area worked together this summer on TSEA's Girls Summer at Sea program.



at sea program

something that would take them outside their comfort zone — they took a leap of faith in applying for the program. The majority of Girls Summer at Sea students needed significant financial support to cover their tuition costs, and none of them even had any experience on the water! This group of girls that became a crew found the adventure they were looking for and, along the way, recognized strengths they never knew they had.

The Girls Summer at Sea program gives high school age girls the opportunity to break out of their social and familial

continued in middle column of next sightings page

disgusting — cont'd

relatively rare. Much more common are infections which, if not treated properly, can result in serious complications.

Take, for example, the case of *California Girl*. The crew delivering Don and Betty Lessley's Pt. Richmond-based Cal 40 home from Honolulu after July's TransPac consisted of skipper Davey Glander, first mate Rich Jones and crew Terry Filson. Shortly after leaving port on July 30, Glander noticed a boil forming on his right wrist. Not one to take chances, he immediately started a course of Keflex (Cephalexin) and began routinely caring for the suspected staph infection by applying hot compresses, keeping it covered with clean bandages and using antibacterial soap. The boil, isolated on his wrist, continued to fill with fluid until the skin couldn't take the strain and it erupted — a scene Rich Jones described as "UH UH GLY!"

Draining the wound seemed to do the trick and Glander, continuing

continued on outside column of next sightings page

If variety is the spice, then September was as delightful a potpourri of sailing conditions as we've ever seen on the Bay. From warm Mediterranean-like zephyrs to nuclear gales (such as here at the International Knarr Championships on the Berkeley Circle early in the month), there was a little bit of everything. We hope you were out enjoying some of it.



SIGHTINGS

disgusting — cont'd

with the course of antibiotics, was as good as new in a couple days. Then things got serious.

While Glander was healing, Terry Filson noticed a similar boil forming on his right elbow. Taking a page out of Glander's infection-fighting playbook, he started on his own course of Keflex and began caring for his wound. Unfortunately, two ugly staph infections depleted the onboard stores of antibiotics, and he soon ran out. Unlike Glander's isolated boil, Filson's infection quickly spread throughout his arm, causing it to swell up to twice its normal size and reducing its mobility to about 10%. "Before we knew it," recounted Jones, "Terry's whole arm, from hand to shoulder, looked like he was doing an Incredible Hulk impersonation."

continued on outside column of next sightings page

girls

routines, put down their cell phones and iPods, and take responsible risks to obtain success and inspiration. The first two weeks are based at SF State where students dive into Oceanography, Navigation, and English classes. In addition, this short land-based preparation time gives the girls opportunities to practice communication tactics, explore tide pools, discover San Francisco's maritime history, and collect gear for their voyage.

With great excitement and anticipa-



PHOTOS COURTESY CALIFORNIA GIRL

— cont'd

tion, the group of students met *Seaward* on July 9 and immediately became the working crew of the vessel, learning the ropes to make the vessel function. The voyage track began with a downwind leg from San Francisco to Catalina Island. After a short visit, the beat north began. The vessel made short port stops at Santa Cruz Island, Morro Bay and Moss Landing before returning to a cool and foggy Bay.

The final week of the program is a time

continued in middle column of next sightings page



Uncle Fester — Spread, Glander's staph infection healed relatively quickly after it, well, exploded (above). Below, Filson wasn't so lucky. The MRSA infection in his elbow got much worse before it got better.



disgusting — cont'd

Luckily, *Cal Girl* wasn't the only 'TransBack' boat on her way home. The Swan 45 *Rancho Deluxe* was only a few hours ahead and just happened to have an EMT onboard. While the two boats were discussing the situation on SSB, a crewmember on the Schumacher 39 *Recidivist* broke in. She was an MD and advised *Rancho Deluxe* to transfer as many antibiotics as they could spare to *Cal Girl* as the infection was clearly becoming very serious.

So, like a scene out of a WWII spy movie, the two boats rendezvoused at night in pitching seas at a point some 1,300 miles from San Francisco. One toss of a tightly wrapped package, and the boats bore off into the darkness.

Within 48 hours of starting on *Rancho Deluxe's* Keflex and Cipro (Ciproflaxin), Filson started feeling better, and the swelling in his arm gradually reduced to a manageable level. As soon as *Cal Girl* tied up at Richmond YC a week later, Filson hightailed it to the ER where he underwent testing and was put on the IV antibiotic Vancomycin for three days. Finally, the infection reached the gruesome draining phase. "Terry estimates that about a quart of liquid eventually departed his arm," Jones reported. "By morning, the swelling was almost gone, and he had regained much of his mobility."

Tests confirmed that Filson had MRSA, an antibiotic-resistant strain of *staphylococcus aureus*. Nearly a month later, he'd had two more courses of different antibiotics, and doctors were discussing surgery to drain the pockets of pus remaining in the joint. In addition, he was undergoing physical therapy to regain a full range of motion.

Staph infections are the most common skin infections in the U.S., and MRSA infections are on the rise all over the country. Many localized staph infections can be treated without antibiotics but, when they go on the rampage, like on *California Girl*, they need to be treated more aggressively.

The Centers for Disease Control and Prevention suggest a preventative approach. First and foremost, wash your hands often, keep cuts and abrasions clean and covered until healed, avoid contact with other people's wounds or bandages (you don't have to tell us twice!) and avoid sharing items such as towels and razors. Antibacterial soap, hand sanitizer and wipes may also help prevent the spread of staph. In short, practice good hygiene.

In the event of a serious infection, cruisers should be well-versed in the administration of antibiotics. Every cruising boat should have a good supply (we don't think two weeks-worth for every crewmember is unreasonable) of a variety of antibiotics and a comprehensive onboard medical book. Talk to your doctor about which meds are right for you, but bear in mind that MRSA is often resistant to general antibiotics such as Cipro (often used for gastric 'bugs'). Many doctors recommend also carrying the sulfa-based Septra (Trimethoprim and Sulfamethoxazole), which targets skin infections.

For more on staph infections, their treatment and how to prevent them, check out the CDC's comprehensive website at www.cdc.gov.

— ladonna

living the dream

When Kenichi Horie sailed out of Nishinomiya, Japan, on May 12, 1962, it's unlikely he knew that his epic singlehanded journey across the Pacific aboard the 19-ft *Mermaid* would serve to inspire legions of young Japanese men for decades to come. But that's exactly what happened.

One of those young men was then-16-year-old Moteo Komatsu. "As a high school boy," the now-61-year-old said, "I dreamed of sailing to San Francisco on my own boat." Last month, his dream became reality when he and his wife Yumiko sailed their *Mirabelle 375 My*

continued on outside column of next sightings page

SIGHTINGS

dream — cont'd

Way under the Golden Gate Bridge after a 48-day non-stop trip from their homeport of Hakodate, Hokkaido.

In the 45 years since Horie's record-setting voyage, Motoe honed his sailing skills by racing in everything from Snipes to his current boat. He also became a respected elementary school science teacher, married a lovely math teacher (33 years ago), and had a family (a son, 32, and daughter, 30) — but he never forgot his dream.

To prepare for the trip, Motoe and Yumiko took a shake-down cruise last year from Hakodate to Chichijima (formerly Peel Island),



"Day one, fog. Day two, fog. Day three . . ."

a tiny eight-square-mile speck of land more than 1,000 miles away. While the voyage had its difficult moments, *My Way* performed flawlessly and left them confident in her ability to take them across an ocean.

On July 18, the Komatsus sailed out of Hakodate and turned left. Motoe's logbook details the unfavorable weather they encountered for the first two weeks or so of their trip, mostly dense fog but also a gale or two. One storm was

bad enough that the couple deployed a 500-ft warp after suffering a knockdown. "We hid below with our eyes shut," they laughed.

Once *My Way* hit the International Dateline, it was like a switch was flicked. The sun emerged, and the rest of the ride, while not exactly a cakewalk — "Every day we were scared." — was more pleasant.

In the black hours of September 1, Yumiko spotted a flashing light in the distance. They pulled out the chart to double check what they hoped was true. "We counted 'One, two, three, four, five' and knew it was Pt. Reyes," Motoe recalled. "I could not sleep that night from excitement!"

The next day, a small boat flying a Rising Sun was greeted cheerily by every passing boat in the Bay. "Every yacht waved," Yumiko said. "It made us very glad." Not only did Bay Area sailors greet our guests with hospitality, so did government officials. Everyone from VTS to the Coasties to Customs treated the Komatsus like family.

When *My Way* was finally settled in a berth at Schoonmaker Point Marina in Sausalito (a recommendation from a yacht club buddy), the Komatsus set to the busy task of sightseeing. At the top of the list was the San Francisco Maritime Museum — home to Kenichi Horie's *Mermaid*, the boat that started it all. Imagine their crushing disappointment to find the museum closed until 2010 for remodeling. "We came to see *Mermaid*," Motoe said sadly when he heard the news.

A few well-placed phone calls by some new friends yielded the impossible: a private viewing of *Mermaid* at the museum's warehouse in Oakland. Bill Doll, Curator of Small Craft, cordially met the couple and allowed them to inspect every inch of the diminutive boat. We're not sure, but we think Motoe may have misted up a little at the sight of his real-life dreamboat.

(Incidentally, Doll noted that such tours are not really "impossible." In fact, the museum gives several full tours every year of their small craft collection, the next being November 3. More info on these free tours can be found at www.maritime.org/cal-boat.htm.)

The Komatsus left the Bay on September 21 on their way to Half Moon Bay and Monterey. They'll leave for Hawaii later this month, spending the winter in the islands, then sail the 3,000 miles to Chichijima non-stop in March. Perhaps their voyage will serve to inspire others to live their dreams. As Motoe pointed out, "Anybody can do it, with enough time."

— ladonna

girls

for reflection and service to the maritime community. Students were introduced to the fine art of sanding, painting and tarring vessels at the San Francisco Maritime National Historical Park before their graduation ceremony at the end of the week.

The three weeks sailing along the California coast were full of wind, fog, waves, rain, laughter and tears. As they reflected on their experience, the students were surprised by all the challenges they faced and were proud of the new techniques they developed to handle themselves and others in moments of adversity. They recognized determination, motivation, awareness, confidence and discipline in themselves. They now identify themselves



The Komatsus, seen here holding 'Mermaid's rudder, managed to wrangle a private viewing of the boat that inspired them to cross an ocean.

— cont'd

as sailors, and will draw on this defining experience as they move onto their next ventures.

The Tall Ship Education Academy (TSEA) is a special project of the Recreation & Leisure Studies Department at SF State University. TSEA is a nonprofit educational organization and is accredited by the Western Association of Schools and Colleges. Private foundations, federal grants and individual donors support TSEA's sliding scale tuition program that provides the significant financial support needed by the majority of our students. Please visit our website for more information: www.tallshipacademy.org.

— nettie kelly
tsea executive director

cangarda — rebirth of a classic

The turn of the century — the last century — marked some watershed years in America. Just a year into it — 1901 — William McKinley was assassinated and Teddy Roosevelt moved into the White House. Guglielmo Marconi received the first trans-Atlantic radio signal. A guy named Henry Ford was trying to market a contraption called the automobile. Orville and Wilbur were still just a couple of eccentric bicycle mechanics.

On the water, the golden age of yachting was in full bloom, and the most elegant flower that year was the 126-ft steam yacht *Cangarda*, built and launched in Wilmington, Delaware, in May. Named for her original owners, Michigan lumber mogul Charles Canfield and his wife, Belle Gardner, *Cangarda* showed all the proper styling 'cues' of superyachts of the day. The most notable of these were the breathtaking clipper bow, adorned with gleaming gold trailboards, a proud bowsprit — and small, almost vestigial masts and sails.

As steam power aboard yachts became more widespread, masts and sails began to shrink and assume a secondary role. Aboard boats like

continued on outside column of next sightings page

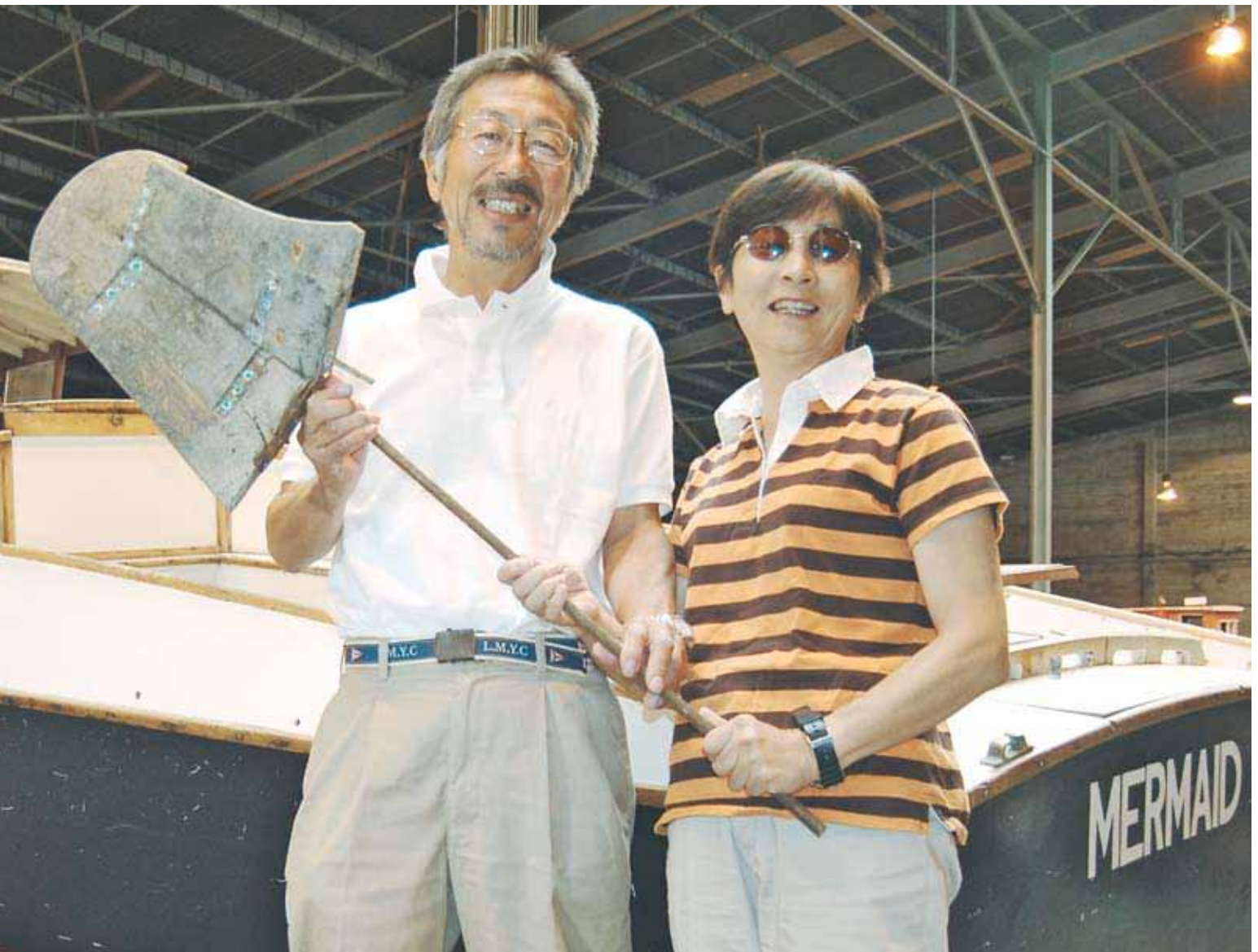

PHOTOS LATITUDE / LADONNA

SIGHTINGS

cangarda — cont'd

Cangarda, the 'lite' schooner rig served three purposes. The first was purely aesthetic: masts continued the classic style of large yachts of the time, which paid homage to the great clippers and golden age of sailing. The masts also helped balance the design and mitigate the boxy houses sprouting from the decks of yachts as accommodations began to migrate topside.

The small sailplan also afforded a degree of fuel economy and comfort (as steadying sails) for the owner and his guests. And third, as *Cangarda* skipper Steve Cobb notes, "There had to be somewhere to fly all those flags."

Cangarda was the talk of the town from the day of her launch, and not just because of her elegance. On the very first cruise, Charles had an 'indiscretion' with a young lady guest, which resulted in one of the most expensive divorces up to that time in U.S. history. Along with presumably everything else, Canfield lost *Cangarda* after using her exactly once. She ended up in the hands of a Canadian senator named George Fulford, whose footnote to history was becoming Canada's first known automobile fatality in 1905.

continued on outside column of next sightings page



CHARLES HANDY



Spread, 'Cangarda' fitting out at Rutherford's Boat Shop in Richmond. Above, Captain Steve Cobb. Right, as 'Magedoma' under the ownership of the Fulford family sometime in the '20s. Note the extensive use of canvas awnings, which were employed as much to shield guests from coal smoke as sunshine. Also note the exposed steering station atop the forward cabin. Crew were apparently meant to be out-of-sight, out-of-mind. The refurbished yacht will retain the upper steering station (covered by plastic in the photo above), but can be controlled remotely from inside as well. By the way, the original yacht was always white. In her second incarnation, she is an elegant dark green.

LATITUDE / JR

fleet week is here

As much as local pacifists detest the thought, Fleet Week once again returns to San Francisco on October 4-9 in all its chest-pounding, flag-waving, saber-rattling glory.

Although the modern version of Fleet Week has been going only since the early '80s, legend has it that the event can be traced all the way back to a visit by Teddy Roosevelt's Great White Fleet, which appeared as a show of support a year after the big earthquake of '06.

Now, as then, the big, flashy part of Fleet Week takes place on the water. For sailors who want to take their own boats out, the big day is Saturday, October 6, when the Parade of Ships comes under

continued in middle column of next sightings page



COURTESY STEVE COBB



cangarda — cont'd

Renamed *Magedoma* (also a conglomeration of the new owner's wife and children's names), the boat remained in the Fulford family for several decades, sailing out of their estate on the St. Lawrence River. Fulford had made a fortune selling 'health tonic', so his family and the yacht were well cared for. Perhaps the pinnacle of the boat's first incarnation occurred in 1927, when Mary Fulford hosted the Prince of Wales, Duke of Kent, and the Prime Ministers of both England and Canada on one famous dinner cruise.

Magedoma's fall from grace began after the government took her over during World War II as a training vessel. Following the war, several owners of good heart but limited means failed to arrest her decay, and by the 1980s, she lay forlornly in Boston, her once lissome hull now malignant with rust and wrapped ignobly in a swimming pool cover to keep her afloat. Even that eventually gave up the ghost, and she sank in 1999.

Act two of the saga began the next year. Elizabeth Meyer, who found and restored the splendid J-Class yacht *Endeavour* (and later founded a yacht restoration school and the J Class Foundation) acquired *Cangarda/Magedoma* — and happily learned that virtually all her machinery, interior and even deck furniture had been removed from the boat and was in safe storage ashore. Meyer put the 'package deal' on the market in the hopes that an owner would appear who had both the heart *and* the means to bring the grand dame back to life.

Such an owner — who prefers we not use his name — appeared in 2002. He has many Bay Area connections, among them Jeff Rutherford, who at that time had recently completed a spectacular restoration of the 1911 P-class sloop *Joyant*. Jeff got the go-ahead for the *Cangarda* job, and three years ago the work began. A team of a dozen to as many as 20 local craftsmen — with Captain Cobb working right alongside them — have been hard at work at Rutherford's Boat Shop in Richmond ever since.

There was not enough left of the original hull to save it. And none of the original drawings by H. Winteringham of New York could be found (although a few sketches made during her building at Pusey and Jones Shipyard in Delaware were tracked down). Ten years ago, the lack of proper drawings would have meant a laborious process of 'taking lines' off the original hull by hand. But that was then. Current technology made it possible for *Cangarda/Magedoma's* tired old hull to be scanned digitally. Andy Davis and Andrew Worm at Richmond-based Tri-Coastal Marine (a marine engineering company dedicated to the preservation of historic vessels) did the engineering and construction drawings for the rebuild. Throughout the process, and true to the

owner's wishes, the goal was to recreate the boat as faithfully as possible to the original — with concessions to modernity as 'out of sight' as possible.

The new hull — all steel like the original — was built first. The machinery — including the six original steam engines — went in next. Then came the interior, deck and, finally, cabins and masts.

Going above and beyond the call of most skippers, Steve Cobb oversaw it all. A native of Camden and graduate of the Maine Maritime Academy, Steve has skippered and/or restored historic ships his whole life. In fact, the soft-spoken Down

Easter seems so perfect for *Cangarda* it's as if fate 'delayed' him a few generations just so he could get the job. Even now, before she's moved anywhere, he knows every inch of the boat and at least the basics of how everything works — because he's either worked on it, installed

continued on outside column of next sightings page

cangarda — cont'd

it, or both. This includes everything in the engine room. On a recent visit, Cobb even took the time to explain the complexities of the boat's triple-expansion, *external* combustion steam engine — which features three pistons of different sizes — in a way that even this mechanically challenged reporter could understand.

And yes, we did say steam. As she has been all along, *Cangarda* — which officially got her original name back at her relaunch in late August — will be powered by steam. In one of those few concessions to modernity mentioned earlier, her new boiler will be oil-fired (with commonly available diesel fuel) rather than coal fired — thus eliminating both coal bunkers and grimy guys tracking black stuff across the decks. The reincarnated yacht also sports stabilizers below the waterline to moderate her rolly tendencies (with only 17 feet of beam, it's thought she'll be fairly tender) and modern electronics, navigation and steering, all cleverly hidden behind original Cuban mahogany furnishings.

Work continues at a brisk pace to ready *Cangarda* for shakedown runs inside the Bay, perhaps as soon as this month. Sometime before the end of the year, Captain Cobb and a crew will head the dark-hulled beauty out the Golden Gate enroute to his and the boat's old stomping grounds of Maine and the surrounding waters. Word has it that when she's not being enjoyed by her owner, she will be docked — and open to the public — at the famed Mystic Seaport Museum in Mystic, Connecticut.

— jr

a varied & diverse ha-ha fleet

As we go to press there are 176 paid entries in the 14th annual Baja Ha-Ha cruising rally from San Diego to Cabo San Lucas, which starts on October 29. By the time the "I don't want my boss to know I'm leaving quite yet" entries come in, there should be about 180, just a few short of last year.

If you go to www.baja-haha.com, you'll see what a terrific fleet it is. The smallest boats are two Rawson 30s, Sam Keston's *Del Norte* and Keith Davis' *La Bonbonniere*, and Bill Thomas' C&C 30 *Captain George Thomas*. The biggest by far is *Havfruen*, P.K. Connor's Thackwray 94 from British Columbia. There are a number of just-launched entries, but the oldest is the Davis brothers' *Alsumar*, a 70-ft S&S yawl that was built in '34. She's back for her second Ha-Ha in a row.

While the Ha-Ha is a cruising rally, there will no doubt be some good battles for first-to-finish in each leg. Among the contenders are Peter Simon's Perry 72 *Elainium*, ex-*Elysium*; the J/160s, Michael Kane's *Novakane* and Joseph Christian's *Syren*; the SC50s, Mike Warns' *Fifty-One Fifty* and Brendan Busch's *Isis*, with another expected; and Neil Kaminer's Farr 58 *Tribute*. There will be 13 multihulls, the newest of which will be Peter and Susan Wolcott's M&M 52 *Kiapa*, which replaces the SC52 of the same name that they sailed in a previous Ha-Ha. There will be at least two female skippers, Patsy Verhoeven aboard the Gulfstar 50 *Talion* from Portland, and Holly Scott, who will be the captain of the SC40 *Promotion*, the West Marine entry. There's even going to be a powerboat, Marc Acosta's Bertram 35 *Wahoo*.

Looking for crew or to crew? The best place will be at the Mexico Only Crew List Party (which also serves as the Ha-Ha pre-Kickoff and Reunion Party) at the Encinal YC, 6-9 p.m. on October 3. That's the last face-to-face opportunity you'll have until the West Marine-sponsored Ha-Ha Kickoff and Halloween Costume Party on Sunday, October 28, the day before the start. If you can't make the Encinal event, we urge you to work the *Latitude 38* Crew List, found at www.latitude38.com. Those of you looking for crew spots will note that there are more folks wanting to crew than skippers looking for crew.

continued on outside column of next sightings page

fleet week

the Gate and proceeds down the Cityfront in the morning, and the Blue Angels put on their show in the afternoon. No time has been announced for the parade (a seven-ship procession led by the missile frigate *USS Vandergrift*), but it generally happens mid-morning.

The Blue Angels' show is scheduled for 1 p.m. but might be delayed because of fog. If you haven't spectated by water

looking for love in all the wrong places?

Maybe you should try a yacht club bar. That would be a likely conclusion based on the experience of Mark and Yvonne Hastings, seen hamming it up in the photo on the next page while hosting a post TransPac party for the Swan 57 *Windswept*.

Originally from San Diego, Mark made the 18-day passage with his Force 50 *Harmony* to Hawaii in July of '05. He purposely coordinated his crossing with that of the TransPac fleet, which is a pretty clever idea. He's been there ever since, having scored a berth at the Waikiki YC.

In April of this year, Yvonne flew from her home in Vancouver to Oahu for a tropical vacation. Somehow she got invited to a fund-raising function at the Waikiki YC, and while at the bar crossed paths with Mark. They're both nice folks, so it's no wonder they hit it off. If it wasn't love at first sight, it had to be close, for they were married just four months after they met.

The happy couple celebrated their honeymoon week by being tireless volunteers for July's TransPac. When they weren't serving as captain and crew on the passenger barge between the Waikiki and Hawaii YCs, they were helping host parties, with guests like Dennis Conner, for the crews of the boats that had just finished.

While the couple have really enjoyed Hawaii, at some time in the not too distant future, they plan on sailing *Harmony* back to California, and then doing a Ha-Ha.

— richard

— cont'd

before, be advised that there are strictly enforced safety zones you must stay clear of. Can't make it Saturday? The Angels will also fly on Friday and Sunday, and the ships will hold open houses through the weekend. For more information on these or the many shore-based activities of Fleet Week, log onto <http://fleetweek.us/fleetweek>.

— jr

ha-ha — cont'd

Don't be discouraged. This is going to be another huge Ha-Ha fleet, and crewmembers often drop out at the last minute.

Again this year, the San Diego Harbor Police's Mooring Office will be keeping track of slip availability as a courtesy to the fleet, and they've set up a special anchorage for Ha-Haers only. Pusser's Rum will again sponsor a rum tasting during the event — and this time they've guaranteed that the booze won't get waylaid in transit. Skippers should note that a Long Beach YC race will arrive in Cabo Marina a day or two prior to the Ha-Ha, but their boats will get the boot at

continued on outside column of next sightings page



ELECTRONIC / RICHARD

SIGHTINGS

ha-ha — cont'd

noon on Thursday, November 8.

The Ha-Ha management has been getting a lot of questions about such things as what documents are needed for clearing in. You just need the boat registration and passports for everyone, and you don't do anything with them until you arrive in Cabo. Temporary Import Permit? Forget about it until you get to Cabo — it's no problem. Ha-Ha Honcho Lauren Spindler advises you to reread the *Latitude First-Timers Cruising Guide To Mexico* that came with your entry packet. It also includes all the contact info for Mexican marinas.

We don't know about the rest of you folks, but we can't wait for the fun to begin.

— richard

bye bye

Who says *Latitude* staffers never sail? This writer and her husband Rob were motorsailing home after a long weekend in Half Moon Bay when the light winds we'd had all day began freshening.

We already had a reef in the main — it was only good for stabilizing the boat in the mixed swell anyway — but the wind built so quickly, it was clear sail needed to be reduced.

After tucking in a second reef and man-handling the small jib to the foredeck, an



birdie

exhausted Rob flopped into the cockpit. Not a minute later, “BAM!” The entire boat instantly became a giant Magic Fingers bed. “What the hell?!”

A quick survey aloft showed our trusty Air-X Marine wind generator — an integral part of our electrical system that, in the four years we’ve owned it, has generated enough electricity to power a small farm — was wobbling at an alarming rate, clearly out of balance. It, in turn,

continued in middle column of next sightings page

A highlight of the Big Boat Series was an exhibition by the ‘experimental’ division. Boats in this class are heavy displacement and are optimized for downwind performance. Look for this as an active class in the future if anyone can ever figure out how to rate them under IRC.



one pole’s position

Krzysztof Szuszkowski of the Terminal Island-based Cal 28 *Na Zdrowie* sails with a motto: “Thru sailing tu health.” His spelling might be a little off, but he’s got the right sentiment. In addition to a motto, Szuszkowski also has a message for others — sailing doesn’t have to cost that much money.

We came to know Szuszkowski after he sent us a photo of his Cal 28 and suggested that it was time for us to put an inexpensive boat on the cover of *Latitude*. He said that the accompanying photo of his *Na Zdrowie* would be perfect because he takes her out every weekend, and because he likes to sail so much that he only has to fill her little gas tank twice a year.

His arguments were good, but the photo wasn’t quite right for the cover. Nonetheless, we had to find



COURTESY NA ZDROWIE

Krzysztof Szuszkowski wants to remind folks that you don’t have to be rich to go sailing.

out more about this guy. It turns out that Szuszkowski came to the United States from Poland in 1983 as a “refugee of the Solidarity Movement.” He came by way of Rome, where he got to shake hands with Pope John Paul II, an experience he found to be “very uplifting.” A few minutes later, he saw the space shuttle *Challenger* fly over Rome piggybacked on her 747. “For a man coming to America from a closed country, it was very meaningful,” he says.

It was interesting for us to learn how Szuszkowski, who still speaks a heavily accented version of English, was able to fare in the United States, a country where it seems that a disproportionate number of the native-born assume it’s their birthright to be both lazy and rich. Szuszkowski doesn’t live in Beverly Hills, but he’s been able to do pretty darn well, thank you. A German Catholic charity arranged for him to move in with a guy in Torrance for a year, where he got a job painting houses. After a year, he was able to buy a car. Not long after that, he started a career as a driving instructor, something he’s been at for 18 years. Although he’s been rear-ended six times, neither he nor any of his students have caused any accidents while he’s been in the car. “I’m very active,” he explains.

Having come to the U.S. with no money, Szuszkowski nonetheless managed to save enough to buy a condo in Long Beach, where he has lived for many years. Although real estate has dropped in value a little recently, he nonetheless says he’s benefited tremendously from the appreciation. “I have a very good life here in the United States,” he says.

For those who contend that the United States is the most despicable country in the world, Szuszkowski offers a little perspective. Having lived in Germany, he says the U.S. is better on several counts. “The United States really is the land of opportunity. It’s also more free than other countries, Germany included. There all the people watch you and judge you. People in America are more optimistic and willing to take risks. And if you try to do something, they encourage you. Of course, there are some people who were born here who seem to just be stuck in place and not trying. If they didn’t have it quite so good, it

continued on outside column of next sightings page

pole — cont'd

would actually be better for them, because then they would be forced to make an effort. Of course, I'm not talking about the genuinely unfortunate people who really do need assistance."

Szuskowski learned to sail on the famous lakes of northeast Poland back in '73. He went there for a visit with his girlfriend, who was an instructor at the sailing club. "She let me steer. After a few minutes she said, 'Why are you steering so crooked?' Her comment motivated me to concentrate and become a better sailor."

One of the ways to sail on the cheap is to crew for others. Szuskowski did that in the Sea of Cortez in '94 aboard the Westsail 32 *Omelo*. If you were cruising down there back then, he says that you might remember him as one of the few guys who was sailing with an African-American girlfriend. Wanting to do the Ha-Ha in '95, he went down to San Diego the day before the start to look for a crew position. He found one aboard *Island Trader*, a Union Polaris 36. It meant he had to rush home, get his gear, and take the next Greyhound bus back to San Diego, but he made it. A Greyhound bus?

As Szuskowski lives on a driving instructor's salary, you might wonder how he can afford both a condo in Long Beach and a series of sailboats. His secret is the boat auctions at Alamitos Bay Harbor. "You can get boats for almost just \$10," he laughs. Although that's an exaggeration, it isn't by that much. "I paid \$1,300 for my Cal 28. Sure, she needed a little work, but she also came with eight sails, including two spinnakers."

You might notice that *Na Zdrowie's* jib has an unusual red stripe on the bottom. Szuskowski explained that the headsail needed a little more sail area. Since he was going to have some cloth added, he figured that he might as well "make a statement" by having North Sails in Costa Mesa make the addition in red cloth. He notes that red and white are also the national colors of Poland. As such, he also makes a point of wearing red and/or white whenever he goes sailing. He loves the United States, but he doesn't forget his homeland.

Over the years, Szuskowski has bought a Cal 25, Cal 27 T-2, a Cal 24 and the Cal 28 from Alamitos Bay auctions. The only other boat he's bought is an Islander Bahama 30, and that was from a bank auction after the owner stopped making payments. "I paid \$6,000 for the Bahama 30, and she had a running engine. I sold her for \$6,500 seven years later — even though the engine wasn't working any longer."

What does Szuskowski like about sailing? "Relaxation, contact with nature, the ability to see whales and dolphins, and sailing to Catalina Island. I've sailed to the island three times this year and hope to do it twice more before the year is over. I've also sailed around the island once. In addition, I've sailed to Santa Barbara Island twice."

We were somewhat surprised to learn that Szuskowski doesn't particularly care for sailing by himself, having done it only a couple of times. "That's never been my goal," he says. In fact, about the only thing that prevents him from sailing on a weekend is if he can't find someone to go with him.

Another reason he's been able to afford to own a series of boats is that he doesn't go overboard with gear. In fact, he hardly has any at all. He's one of the few guys we know in modern times who has sailed to Catalina without a GPS. "I never had one. I just remember the angles to the island." He also doesn't worry about getting caught in fog in the channel, unable to see the freighters. "I've never been caught in a thick fog. If I was, I'd listen really close. Besides, the ships slow down when they get close to port."

Szuskowski is aware of one of the contradictions often found in marinas. "I've seen thousands of boats in marinas, often big boats, that are never taken out. I only have a little boat, but I take her out almost every weekend because she brings me great joy. If I didn't use her, I would sell her. Once I went two years without a boat, but I

continued on outside column of next sightings page

birdie

was causing the mizzen mast to pump so violently, we were half afraid the boat would shake apart.

The steady 35-knots of wind kept the blades — or what was left of them — spinning. It wasn't until we turned the corner



Seagull suicide — A small bird flying downwind was big enough to take out our trusty wind gen.



— cont'd

at Mile Rock that it slowed enough for us to assess the damage. Of the three 20-inch blades, only one and a half remained.

Though there were no feathers or blood to be seen, we came to the conclusion that a small bird had performed a kamikaze dive on us, a theory confirmed by the manufacturer, Southwest Windpower.

"These kinds of accidents are extremely rare," explained a customer service rep, "as the RPM of the Air-X is slow enough for birds to keep sight of the rotating blades." Guess our little guy must have been looking the other way.

— *ladonna*

pole — cont'd

couldn't take it, so I bought another one at auction."

Is that the sound of some young and impoverished sailor whining that a Cal 28 isn't enough boat for him/her to actually go somewhere? Funny, we remember that Mike Pyzel of Santa Barbara has sailed his Cal 28 to the Channel Islands about 500 times — no exaggeration — did the Singlehanded TransPac with her, and recently used her to cruise Mexico. And just the other day we had a chat with Bob White of Costa Mesa, who works for Orange Coast College's School of Sailing and Seamanship. He mentioned that when he was young, he and three other guys cruised from Newport to Vanuatu aboard a — you guessed it — Cal 28. They didn't have a GPS either, because those wouldn't be invented for another 25 years.

We've said it once and we'll say it again, money is a phony obstacle to sailing and cruising pleasure.

— *richard*



PHOTOS LATITUDE / LADONNA

2007 ROLEX BIG BOAT SERIES

Except for the sailors who like it rough, the Rolex 43rd Annual St. Francis Big Boat Series was the most partici-

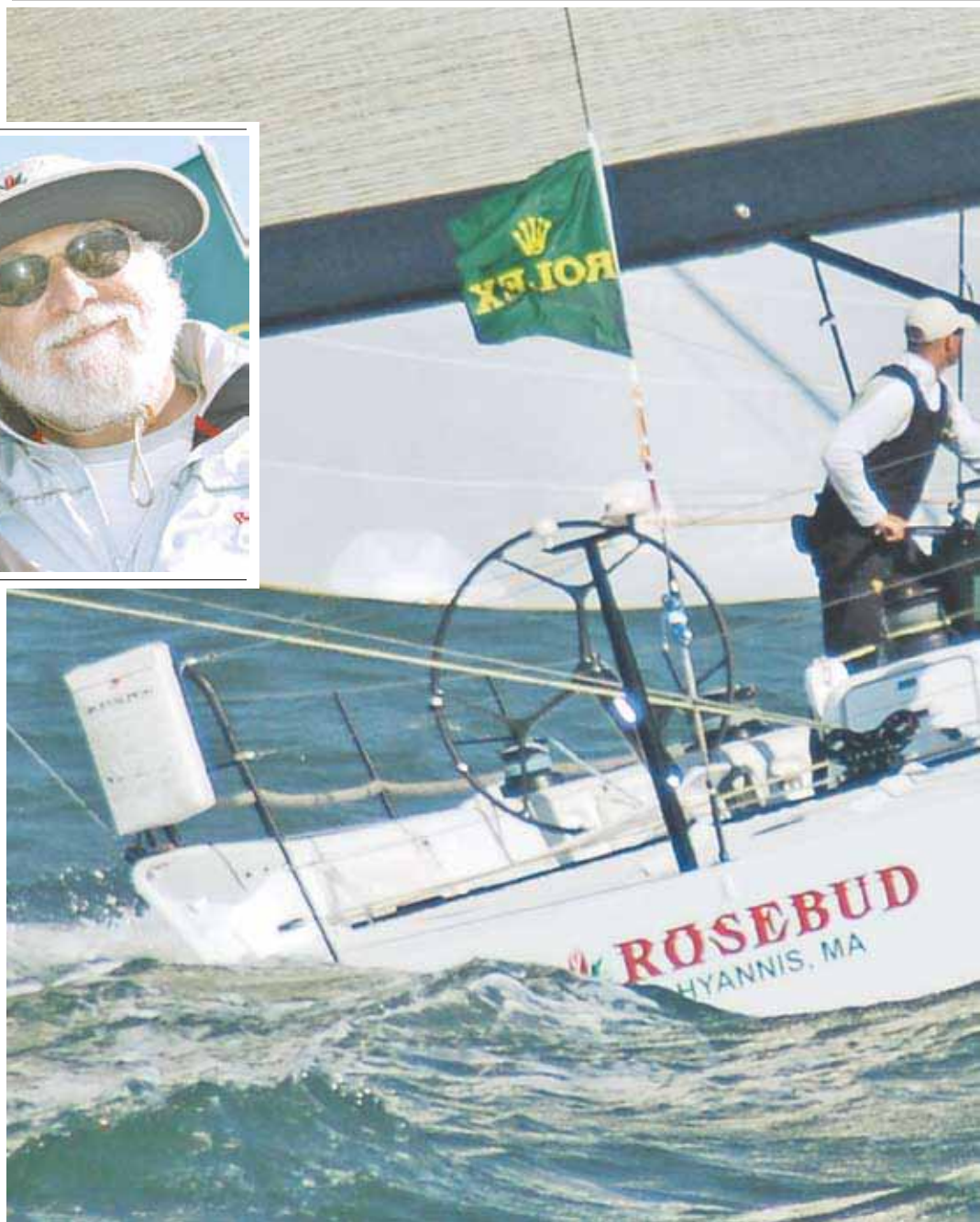

LATITUDE/RICHARD

pant-pleasing one in memory. Forget the strong, cold winds and big chop that you normally associate with the event, as the 1,000+ sailors were treated to a seven-race series that was all sunshine and 10 to 17-knot winds. And thanks to the flat water of a rare flood tide series, most boats didn't even get their decks wet. The weather was so Newport Beach-like that prior to the start of the delayed final race, a number of overheated sailors stripped down and jumped into the chilly Bay for a swim.

Boats and owners came to San Francisco from Tokyo, the East Coast, the Midwest, Canada and Southern California. With the America's Cup long over, many veterans of that event, such as Gavin Brady, who had been a principle helmsman on the *BMW Oracle Team*, came to sail on the top boats. Kiwis were well-represented, of course, but there were also sailors from South Africa, Europe and Australia.

Compared to some previous years — such as exactly 20 years ago when every quality maxi in the world came to San Francisco — this year's event was a little short on the really big boats. But it made up for it in numbers — 112 boats in four IRC fleets and six one design classes. It was a near record.

The boats ranged in size from the Melges 32s to the Tanton 73 *Velos*, although the glamour boat of the event was former Vallejo resident Roger Sturgeon's *Rosebud*, the first boat built to the STP65 box rule. Several of the top boats were right out of the box. Dave Kirby's new J/122 *TKO*, for example, arrived from France just six days before the first starting gun was fired. And while *Rosebud* had done the fluky TransPac, this was her first

major around-the-buoys series. This was also the West Coast debut of the Melges 32 one design class. Another cool boat making an appearance was *Mayhem*, a TP52 previously owned by royalty — King Juan Carlos of Spain.

As well, it was fun to see some older boats participating, such as Chuck Weghorn's *Zamazaa*, the only wood boat in the fleet. The still fine-looking Farr 52 first raced — and won — in the Big Boat Series way back in 1980 when Jimmy Carter was still in the White House.

Just because a boat was senior didn't mean she couldn't do well. For example, Keith Brown's Peterson

46, *Aleta* — which is even older than *Zamazaa* — took one race in her division, and the 20-year-old Jeanneau 45 *Acabar* won hers. Said owner Jean-Yves Lendormy, "The IRC handicap rule allows older boats to be competitive if they try hard enough." And his and several other senior boats obviously tried hard.

Despite the variety of types and ages of boats, and the fact that no handicap systems works perfectly in all situations, the IRC racing was very close. Those four classes, for instance, were decided by an average of just one point each, with IRC B being won by a margin of just 12 seconds. And several IRC classes had

THE FLOOD OF '07



Roger Sturgeon's beautiful STP 65 'Rosebud' was deceptively fast despite the 'civilized' conditions of this year's BBS. She got even faster around mid-Series when the crew finally figured out how to sail the new boat around the buoys. Inset, Jack Halterman (left) with Isobel and Roger Sturgeon.

individual races where the top three boats were separated by less than 20 seconds. No time differentials were kept in the six one design classes, but the race committee members had to be on their toes, because boats often finished in clumps, particularly in the 34-boat J/105 division.

While all the participants agreed that the moderate wind and flat water sailing was pleasant, there was some debate as to whether a flood tide series was a good thing. "I loved it," said sailmaker Kame

Richards. "I know that it's not really fair for shorter boats in the handicap divisions, but in one designs such as the Express 37s, it's great. In fact, I would lobby hard for all flood tide races in the future." A number of San Francisco sailors, however, said they would have preferred lots more wind and big chop, as their boats are set up for that and it affords some advantage over out-of-area sailors who are less used to such conditions.

The good side of the mild conditions

was that there was little damage to sailors, boats and gear. There were no dismastings or broken booms. So few sails were torn that some loft employees were seen killing time with the Maytag repairman. There was one broken rib and a few bruises, but unlike many Big Boat Series, we didn't see a single ambulance.

IRC A — Samba Pa Ti

IRC A was the heavy hitter class, of course, with the top three boats being John Kilroy, Jr's Los Angeles-based, year-old TransPac 52 *Samba Pa Ti*, Roger Sturgeon's Ft. Lauderdale-based

2007 ROLEX BIG BOAT SERIES

Rosebud, and Michael Brennan's year-old Annapolis-based R/P 45 *Sjambok*. All three boats were sailed by nearly all-pro crews, many of whom were veterans of events such as the America's Cup and Volvo (round the world) Ocean Race. The plane tickets to fly these crews to San Francisco cost more than some boats in the lower divisions.

While Larry 'fourth richest man in America' Ellison managed to drive *Sjambok* to class honors in the third race, the real duel was between the proven *Samba Pa Ti* and the new *Rosebud*. In a sense, both boats won. Not hurt by the lighter-than-normal winds, *Samba* won three of the first four races, which helped power them to ultimate victory in the class. *Rosebud*, whose crew was still getting used to the much bigger and heavier 65-footer, won the last three races to finish just one point back of *Samba*. Given the considerable difference in boat lengths, there was never any side-by-side competition. Nonetheless, both owners were happy with the series and the results.

"This the only non-tradewind regatta that I really like," said Kilroy, who in addition to a home in Malibu has one in the Marina District just a five-minute walk from the yacht club. He also keeps *Malia*, the family's immaculate Morris 42 cruising boat at the St. Francis for much of the summer. Kilroy's affection for the Big Boat Series is meaningful because he's long been an international competitor at the highest levels. "The Big Boat Series has consistent wind,

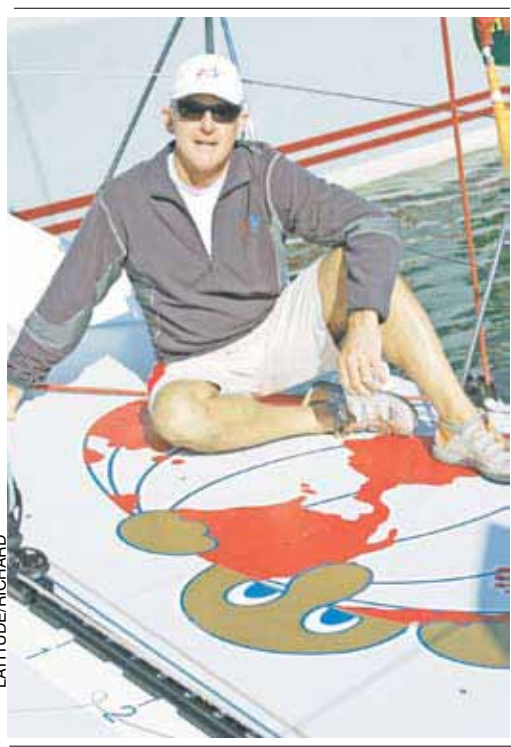

great scenery, the wives can be here, and the yacht club is terrific." The proof that he's not blowing smoke for the local media is that he's raced on Kilroy family boats in every Big Boat Series for the last 42 years! How is that possible for such a fit and youthful-looking guy? He started at age 14 aboard his dad's 73-ft *Kialoa II*, and before long was driving the 79-ft *Kialoa III* on the downwind legs.

"Most recently I did six or seven



Above, let's go surfin'! Even in moderate breeze, 'Samba Pa Ti' can get up and boogie. Left, owner John Kilroy, Jr. with the famous 'family crest' that has graced all the 'Sambas' and 'Kialoas' (as well as most of the Pacific and European theaters in World War II).

Big Boat Series with my Farr 40 *Samba Pa Ti*, winning all but two," Kilroy said. "The Farr 40 is a great class, with excellent competition and a wonderful group of people, but there's no comparison between those boats and

my B&C-designed TP52 *Samba*. The new boat is longer, all carbon, and has an all pro crew except for two. It's like the difference between an F1 racer and a production Porsche." Although *Samba* hit 30 knots during the Coastal Cup earlier in the year, the moderate winds in the Big Boat Series prevented her from getting over 17 knots.

Given the fact that it was a flatwater series, Sturgeon's longer and more pow-

erful *Rosebud* might have been expected to have an advantage over *Samba*. The three wins at the end suggest they probably did — but it took until mid-series for the crew to learn how to get the new boat up to speed around the buoys. Sturgeon, who made his fortune as a computer scientist "before the field even had a name", has owned a series of boats named *Rosebud* — an SC27, SC52, and a TP52 that was wildly successful on the Pacific, Atlantic and Caribbean. The one constant over all the years has been helmsman Jack Halterman of Santa Cruz.

"The difference between my 65 and the old 52 is simple," said Sturgeon. "The 65 is just that: more simple. It has no spinnaker pole, no reaching strut and no overlapping sails. And thanks to hydraulics everywhere — backstay, headstay, jib clew and other places — she's more efficient and therefore doesn't need any extra crew. Furthermore, her 16-ft deep drop keel gives her much more righting moment than the old boat. Despite being

THE FLOOD OF '07



bad weekend for Ellison, as he drove the boat to a first and two seconds in five races. What's more, after being roundly criticized by analysts because Oracle spent \$12 billion on acquisitions last year, he knew his software company was about to deliver the kind of quarterly numbers not seen since the dot com bust.

IRC B — Kokopelli²

"The racing was so bloody close," said Scott Easom, starting helmsman and tactician for Lani Spund's Santa Cruz-based SC52 *Kokopelli²*, winner of Class B. Her stiffest competition in the 10-boat fleet came from Mike Diepenbrock's Sacramento-based Swan 45 *Rancho Deluxe*, and Saratoga's 86-year-old Sy Kleinman, who was racing in his 26th Big Boat Series, the 14th aboard his Schumacher

ROLEX/DAN FORSTER

54 *Swiftsure II*. Easom could have been referring to the fact that the three boats corrected out a total of 18 seconds apart in the fifth race, or that *Koko* and *Rancho* were tied going into the last race, with *Swiftsure* still in striking range.

And it's not as though the boats are particularly similar. "*Kokopelli²* is really just a fast cruising boat," points out Spund, "most suitable for sailing off the wind in the open ocean, not around the buoys." And while it's true that Diepenbrock's *Rancho* was designed to the IRC rule, she was significantly shorter than the big boats — 7 and 9 feet, respectively — and therefore at a disadvantage in the flood conditions. As for the veteran



LATTITUDE/RICHARD

Swiftsure, she's heavier than the rest, and sails to her rating best in 20 or more knots of wind, conditions that weren't to be found on the Bay that week.

As it turned out, *Kokopelli²*'s four first-place finishes, including one in the last race, were enough to keep her in front

almost twice as heavy as the 52, the 65 is equally responsive, but unlike the 52, it doesn't lurch. The old boat was like riding a mechanical bull, while this one is much more controllable and fun!" Even after a string of seconds and thirds in the first four races, the smile on Sturgeon's face said everything about his feelings for the new boat.

Rosebud looked elegant zipping around the Bay, although her top speed of 19 knots wasn't anywhere near the 27 knots she'd hit in practice. The only people who didn't like her look were photographers, because she moved through the water with so little fuss that still photos don't adequately convey her power or speed. After the Series, *Rosebud* was quickly packed up for shipment to Sydney. If the weather doesn't look life-threatening on Boxing Day, they'll race to Hobart.

You had to feel for *Sjambok* — named after the South Africa whips made from hippopotamus hides — as the class break left them in a weak position. Being 7 feet shorter than *Samba* (and 20 less than *Rosebud*), even their all-star crew couldn't regularly overcome being the 'short straw'. But overall it wasn't a

Below, despite smaller sails and a worsened handicap, 'Kokopelli²' shot four bullets and won IRC-B. Above right, Lani Spund and 'Koko' tactician Scott Easom.



2007 ROLEX BIG BOAT SERIES

of the pack. This despite the fact that her new smaller sails somehow resulted in her handicap getting worse. Spund



drove all but the starts, but says he doesn't have to hold the wheel to be happy. "I like to drive, trim, tweak — whatever it takes to help make the boat go faster and safer."

One of the most helpful things he did was agree to cut loose a \$10,000 spinnaker

after a dousing snafu at the leeward mark of a close race. Unlike in the America's Cup, there was no team boat trailing to retrieve it, so it's becoming a marine habitat on the bottom of the Bay.

Once the series was over, Spund was trying to figure out what he needed to do to get a slot in next year's 'sold out' Pacific Cup, but also had visions of moving up to a Santa Cruz 70.

Despite never winning a race, the consistent *Rancho* finished just two points back, having come in 90 seconds off the pace in the final race, having suffered particularly for being the short boat on the 'Bay tour' course that featured lots of reaching. Nonetheless, their second in class capped an intense season of racing that included a first in division in the TransPac.

"I drove the entire series," says Diepenbrock, "but I want to compliment Seadon Wijsen for putting together such an excellent crew. I've never sailed on such a quiet boat." As it was, Diepenbrock did much of the talking. "Because *Rancho* has such a long boom, the absolutely critical guy was Kiwi Andy Escourt,

my mainsheet trimmer. We talked the entire time, and he really helped."

For the Diepenbrocks, yacht racing is a family affair; it was important to Mike that his brother Jim and teenagers John and Laura were able to race with him.

Even more than the other two boats, Kleinman's *Swiftsure* was weather dependent. "The boat is set up for 15 knots or more," said helmsman Steve Taft, "so if it blew under that — and particularly just six knots, like in the first race — we were screwed." The sixth place finish in the first race, by far their worst, indeed proved to be their undoing. Despite finishing third, it was a happy group of 16 sailors aboard *Swiftsure*, in part because so many of the core group have been racing the boat for the last 14 years. "We just had three new guys on the bow," says Taft, "plus Staff Commodore Doug Holm."

IRC C — TKO

"It was just like a movie script," remembers Southern California's Dave Kirby, who looked inexplicably glum when he docked his boat after the last race of the series. After all, his even making it to the series was something of a Cinderella story — after a lengthy boat search that included everything from a Melges 32 to a Swan Club 42, he'd decided on a new French-built J/122 only a

Below, Jean-Yves Lendormy goes for the traditional winner's swim after finding out his 'Acabar' won IRC-D. Above left, her signature gold spinnaker flying, 'Acabar' comes down to the finish of the final race.

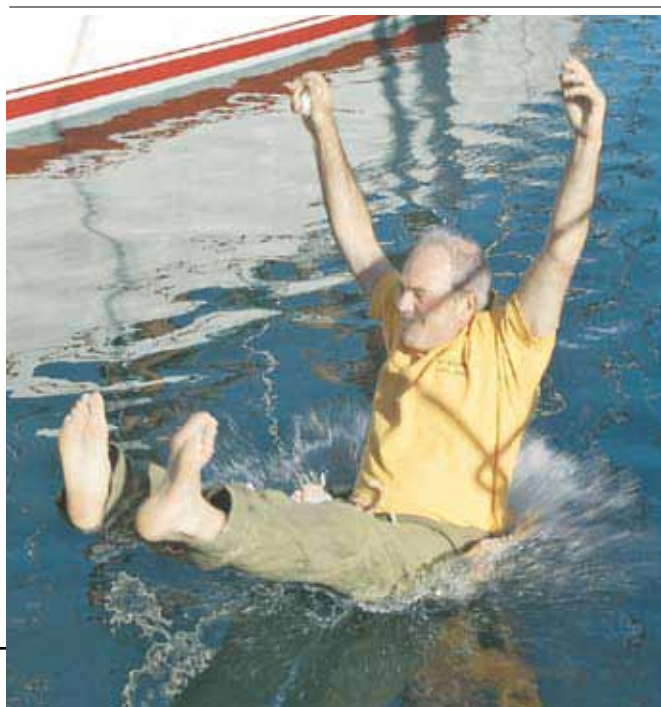

short while ago, and somehow managed to get the 40-footer delivered to the Bay just six days before the first gun.

Although he'd only sailed on the Bay once before, Kirby then lucked out to get former sailmaker and J/Boat dealer Norm Davant on the boat. (Davant's reputation as a ball-buster was borne out when, in the process of introducing the crew, he told us, "These are the guys who survived. The others couldn't take the pressure of sailing with me.")

"Yes, Norm is intense, but he's also an unbelievable tactician and knows every rock and nuance of current on the Bay," says Kirby. "And I can't say enough about Jeff Trask, Robin Jeffers and the rest of the crew."

After five races, *TKO* had a comfortable lead over Mike Garl's Redwood City-based Beneteau 40.7 *White Dove*. Between the fifth and sixth races, Kirby gathered the crew together in the cockpit to talk about what good shape they were in and the importance of "not doing anything stupid." Then, with a minute before the start, Davant told Kirby to spin the boat around. He did, and the boat came to a halt. "Unfortunately," says Kirby, "our mast guy, A.J. Vallera, kept right on going — under the lifelines and right into the Bay!"

"Suddenly I was in the water!" remembers Vallera. "But there was so much adrenaline pumping that it didn't even seem cold. I did all right dog-paddling like crazy with all my gear on, but I can tell you, I wouldn't have been able to do that for very long."



Above, the second IRC-C start on Friday. 'Inspired Environments' is in the foreground, with 'TKO' farther down the line. Right, new J/122 fanatic Dave Kirby with tactician Norman Davant. Below, A.J. Valleria took a dive in the sixth. We're not sure if that finger indicates 'TKO's division win or how many ribs he broke falling off the boat.

It took TKO a couple of minutes to get back to Vallera, whereupon grinder Bill Brandt simply yanked him out of the water and they started racing again. It took a valiant effort by the TKO crew to claw back to seventh. And all of a sudden, they were tied with *White Dove* going into the regatta-deciding final race.

The 'Bay tour' was a nail-biter. Even though TKO excelled in the reaching conditions of that race (as opposed to all the other windward-leeward courses), she just couldn't shake *Dove*. "A couple of our guys had been keeping track," says Kirby, "and estimated we'd lost the final race — and therefore the regatta — by something like 10 seconds. I have to admit that I'm not a particularly good loser, so when *Latitude* came down to take my photograph, that's why I wasn't really smiling."

Finally, Davant couldn't take the suspense any longer. He went up to the club to get the official results and a few minutes later came running back down the ramp shouting, "We won! We won!" Indeed they had — by a margin of 12 seconds. Kirby finally broke

into a smile as big as if he'd hit a walk-off homer in the seventh game of the World Series. It really *had* been like a movie script.

It's probably moot to say that Kirby, nephew of Laser designer Bruce Kirby, has become a J/122 fan. Make that fanatic. He can reel off technical and personal reasons why this particular J Boats design, currently built only in France, is so much better than all others, as well as all her competitors. According to him, it's a combination of performance, headroom, and very importantly, it makes a great cruising boat to Catalina and the Channel Islands for him, his wife and their two sons.

One guy who isn't a poor loser is Mike Garl of *White Dove*, who seemed jubilant with their series. "Oh what a great regatta it was! Even though we only lost by a few seconds, we felt we sailed as well

as we could. It was the most competitive regatta — and therefore the most fun — that we've ever done. Our hats are off



LATITUDE/RICHARD

to TKO, as they sailed a great series.

"The funny thing is, we weren't even going to do the regatta until three weeks ago, at which point rigger Jon Stewart stepped in and put a great crew together. Jon and his guys deserve all the credit for our having sailed so well."

John Siegel and his San Francisco-based Wylie 42 *Scorpio* finished an uncharacteristic third, having won their Big Boat Series classes, often handily, for the previous four years. "*Scorpio* is kind of heavy and has non-overlapping headsails, so she's most happy sailing upwind in 20 to 25 knots of wind," says Siegel. "But I don't want to take anything away from TKO and *White Dove*. Even though we had 10 of our 11 crew back from last year, those were the dominant boats. But you can bet that we'll be back next year!"

IRC D — Acabar

Jean-Yves Lendormy and his *Acabar* crew captured IRC-D the old fashioned way — they earned it. After coming to



LATITUDE/RICHARD

2007 ROLEX BIG BOAT SERIES

the Big Boat Series for the first time in 2003 (and finishing next to last) 'J.Y.' and the dark-hulled Jeanneau 44 have moved slowly but steadily up through the ranks: mid-fleet the next year, third in '05, second in '06 and — finally — first this year.

But like we said, they earned it. Ping-ponging back and forth the entire series with Gerry Sheridan's '06 division winner *Tupelo Honey* — *Acabar* corrected out to win every second race of the day; *Tupelo* won every first race — it came right down to the wire in the Bay tour. For the first time in the series, *Acabar* beat *Tupelo* both boat-for-boat and on corrected time to take that final contest.

As with every race, as soon as *Acabar* was tied up at the St. Francis docks, J.Y. popped open a bottle of Veuve Clicquot champagne from his native France and filled glasses for each of his crew — Dan Nitake, Bryan Bennett, Dominique Roddier, Eddie McCarthy, Enrique Land V, Gilles Combrisson, Iwan Streichenberger, Pascal Michailat, Patrick Perigaud, Richard Leevey and Tim Meaney. (Also per usual, he offered bubbly to everyone who passed by.) But the mood on Sunday afternoon was a bit reserved as they waited for overall results to be tallied. After about 30 minutes, word came down they had won. And about 30 seconds after that, J.Y. was flying into the water in the winning skipper's traditional dunking.

"*Acabar* is 20 years old and not the fastest

boat on the water," said the skipper later. "I am grateful to the St. Francis YC for inviting us to race in this terrific series, and for using the IRC handicap rule" — which as he noted earlier allows older boats to be competitive if they try hard enough.

No one will deny that the *Acabar* crew tried hard, both at the dock and on the water. As for the former, Gilles Combrisson preps the boat every year, and this time, with Scott Easom's help, he says *Acabar* was the best she's ever been. On the water, most of the crew have been sailing together for several years and know the boat well. J.Y. gives a special nod of appreciation to tactician Dan Nitake — "a small boat sailor who had us spinning around like a Moore 24 at the starts," says J.Y. "After that, he kept us out of traffic and sailing our races the way we needed to."

In the end, "Nothing broke, nobody got hurt and we had a lot of fun," says the skipper. Somewhat surprisingly, the sailor who was perhaps the most pleased about *Acabar's* victory was *Tupelo Honey* owner Gerry Sheridan. "J.Y. is a good friend and a great competitor. We didn't give them an inch on the water, but they sailed well and deserved to win. I couldn't be happier for them."

Below, Jeff Pulford's 'Bustin Loose' doing just that off Pier 39. Left, it was a 'thumbs up' series all the way.



Sydney 38 — Bustin Loose

A look at the scoreboard might lead you to believe that Jeff Pulford and crew aboard the Monterey-based *Bustin Loose* had an easy trip to the winner's circle. Not so. Despite scoring five bullets in seven races, Pulford's seasoned crew had to work hard for every win, as this six-boat fleet held some of the regatta's tightest boat-for-boat racing.

Proud as he was of taking top honors, Pulford was quick to point out that his crew deserved most of the credit. "They



LATITUDE/ANDY



THE FLOOD OF '07



don't actually let me go near the wheel or the foredeck," he joked. In addition to tactical guru Bill Erkelens and stellar helmsman Larry Gamble (with whom Pulford's been campaigning since 1982), the consistent crew work of Chris Gattward, Jeff Brantley, Mark Nail, Merritt Bruce, Cam Lewis and Kim Desenberg helped earn them class honors.

The team's run of three consecutive bullets ended in the second race on day two. While beating upwind in a tight lineup, they tacked for clear air — only to spot a 22-ft daysailer with an ominous 8-ft bowsprit plodding along, with the skipper facing aft, fiddling with his self-steering. Gamble put in an immediate crash tack and the two boats missed each other by what seemed like inches. "I could easily have grabbed that sprit," recalled Lewis. But the maneuver took them out of contention in that race. Michael and Kate Kennedy's *Copernicus* — '06 defending champs — scored the win.

The Chicago-based Kennedys saw their own share of high drama. During their pre-regatta practice session Wednesday evening, *Copernicus'* wheel attachment showed signs of imminent failure. It held together during the morning race, but just as the one-minute gun sounded prior to the second race, the spindle failed and Kennedy found himself charging toward the starting line with zero control. Tactician Jud Smith (2006

Philippe Kahn and crew tamed their wild new 'Pegasus' to take division honors. The BBS marked the West Coast racing debut of the new Melges 32 one design class.

Rolex Yachtsman of the Year) reportedly advised, "Don't worry about getting out the emergency tiller now, just get us a good start." Amazingly, they did pull off a fine start, steering with only the sails. Even more amazing: they not only completed the race — they got second! And get this — because the emergency tiller was so short, Kennedy literally had to lie down on the cockpit sole to steer while Smith gave him directions, i.e. "Come up two degrees. Down two degrees." The steering and boat were both back in action again the next morning, thanks to

Swim call! When hot, windless conditions delayed the start of the Bay tour, 'Zamazaan's crew decided cool off.

the nightowl efforts of KKMI craftsmen.

Going into the final race, *Copernicus* and Peter Kreuger's *Howl* were tied in points for second. On the first beat off the line they shadowed each other as if tethered together by a shock cord, but *Copernicus* eventually pulled ahead by several boatlengths on a port tack flyer and held off *Howl* until the finish, insuring their second place slot in the class standings. Kennedy hopes to convince the four other Chicago-based Sydney 38 owners to migrate west for the series next year.

Melges 32 — Pegasus

Philippe Kahn's Santa Cruz-based *Pegasus* won five out of seven races to claim honors in the Melges 32s, the newest one design class in the BBS. These ultralight boats are so performance ori-



PETER LYONS/WWW.LYONSMAGING.COM

2007 ROLEX BIG BOAT SERIES



ented that they can be fully powered up in just seven knots of wind. And they're no slouches off the wind, either. During one fast spinnaker reach to the finish, *Pegasus* held her own with *Samba Pa Ti*.

As has long been Kahn's M.O., he had a very talented crew: Richard Clarke, Federico Michetti, Curtis Florence, Michael Bradley, Cindy Alsop, Paul Hickey and the boats' namesake, Harry Melges. But having only acquired the boat three weeks before the Big Boat Series, Kahn had two coaches, Brian Hutchinson and Bruce Mahoney, who put his crew through frequent regimented practice sessions to bring them up to speed.

"Our biggest challenges were boat handling and rig setup, but we managed well and Kahn is a big fan of the boat," said Mahoney. "The cool thing about this class is that the boats were so close, even after 14 miles of racing."

Joe Woods' *Red*, from Torquay, Devon, on the southwest coast of England, sailed

Above, 'Mr. Magoo' (28289) charges for the finish line of the last race in a near photo finish with 'Dayenu' (28904), 'Ebb Tide (147) and 'Chance' (28484). Inset, Steve Madeira.

a fine series to finish just three points back. Richard Leslie's San Francisco-based *Southern Cross* took third in the seven-boat fleet.

The Melges 32 — essentially a Melges 24 on steroids (this boat needs winches)

— has attracted a lot of local attention. *Stewball's* Caleb Everett says the Melges is so different from his previous *Stewball*, an Express 37, that the learning curve has been steep. "For my first big race of the season with a thrown-together team,

The name of Ashley Wolfe's TP52 speaks volumes about the '07 BBS. With 112 boats and a flood tide, the Cityfront was like 101 at rush hour — coming and going.



THE FLOOD OF '07



of the two finished ahead of the other would win the series.

The big surprise for Madeira and his crew — tactician Dave Grandin, Rich Born, Matt Gorman, Ken Thompson, Tom Allard, Tom Glockner, Darren Goldman, Greg Meagher and Jeff Lawson — was that they were in contention at all. “We were not

sailing well on Thursday, and Friday wasn’t much better,” says Madeira. “Then on Saturday, it was like the stars aligned all of a sudden. We got two good starts, and Barry broke a jibsheet right after the second start — and all of a sudden, we were on our way.”

The final race on Sunday was the Bay tour, which Madeira says has never been *Magoo's* strong suit. As if you couldn’t already cut the tension with a rigging knife, the absence of wind in the morning caused a long postponement and a shortening of the course. When they finally started, *Chance* pounced on *Magoo* and the two dueled tacks from the T.I. start all the way to Alcatraz. When they finally broke apart — *Chance* splitting away toward the Cityfront, *Magoo* staying out — they were running next to last in the fleet. When they came back together, *Magoo* had the lead by . . . well, about a nose. From there on to the finish, the guys on the ‘green machine’ concentrated on working up through the fleet, staying ahead of *Chance* and trying not to foul anyone else — no mean feat when

my crew were some of the best on the Bay,” said Everett.

The mild sailing conditions were no “bummer” for the Melges owners and crews, whose boats, with their huge mains, took off in the light winds when other boats were at times struggling to keep their spinnakers full.

J/120 — Mr. Magoo

Who knew déjà vu could be so stressful? Last year, Steve Madeira and his *Mr. Magoo* crew won the J/120 division by a literal nose — crossing the finish line of the last race about 1 foot ahead of a boat they had to beat, thereby topping Barry Lewis’ *Chance*, which to that point had led the whole series.

Well whaddya know: this year, after six races, it once again came down to the wire for *Chance* and *Mr. Magoo*. The boats went into the final race tied at 15 points apiece. That was far enough ahead that it didn’t matter where they finished in the fleet in the final go-around — whichever

you’re not only competing with boats in your own division, but threading your way though several other fleets coming and going. “Sometimes it was hard just to figure out which boats were in our class,” laughed Madeira, noting that from a distance, a J/105 looks a lot like a 120 — “And there were lots of 105s out there.”

Every time *Magoo* picked off a boat, they’d look back to see that *Chance* had done the same. By the time they rounded the top mark and turned for the final run to the finish, Madeira found himself sandwiched between *Dayenu* and the all-Japanese charter crew on *Ebb Tide*. Off on the port flank was, gulp, *Chance*. All four boats flew down the Cityfront abreast of one another in perhaps the most thrilling stretch run of the Big Boat Series. Towing across the line on *Dayenu's* wake, *Magoo* finished fifth in that race, but it was ahead of *Chance* and thereby good enough for their fourth consecutive BBS victory. “My guys really pulled it together,” says Madeira, “and that made all the difference.”

1D35 — Double Trouble

From the perspective of her competitors, the only trouble with Andy Costello’s *Double Trouble* is that she just keeps winning. Coming off her second 1D35 Nationals win in a row just last month,

she won five of seven races to best her seven-boat class by the biggest margin of any in the Big Boat Series.

Having been

Below, 'Double Trouble' in a rare following situation. Right, Andy Costello.



2007 ROLEX BIG BOAT SERIES



a class winner in the Big Boat Series two years ago with his Sydney 38 of the same name, Costello again benefitted greatly from the help of his "faithful" crew: tactician Jim Barton, Patrick Whitmarsh, Mark Breen, Morgan Gutenkunst, Simon Werner, David 'Captain' Morgan and Cameron McCloskey.

"They're all dinghy sailors," said Costello, "so they suit the 1D35 well, because she's just a big dinghy."

Given the end result, *Double Trouble* had a surprisingly bad finish — fifth — in the first race. It was caused by a combination of being over early and a failed jib tack that left them without proper luff tension. With Peter Stoneberg's chartered *Shadow* just one point back but fading after four races, he and tactician John Bertrand (who helped found the class) decided to match race *Double Trouble*. The result wasn't very good for *Double Trouble*, as she finished fifth. But it was a disaster for *Shadow*, which finished last. That, combined with Barton's gutsy call in the last race to fly a chute around the north side of Alcatraz rather than a jib around the south side, sealed a comfortable eight-point victory in the seven-boat fleet.

Well-oiled machine — Chris Perkins (driving) and his 'Good Timin' crew once again outsailed 33 other boats to rack up their fourth win in the ultra-competitive J/105 class.

Shadow hung on to finish second, with Gary Fanger's *Sweet Sensation* taking third. Mario Yovkov's *Great Sensation* 'coulda been a contender', but a broken jib halyard in the fourth race resulted in a DNF. In fact, most boats in this fleet had the potential to be contenders. "The fleet had such tight racing that almost everyone led at one point or another," said Ellen Hoke, a competitor and the 1D35 National Class Coordinator.

J/105 — Good Timin'

This was Chris Perkins' fourth win in seven tries in the J/105 division off BBS, which had 34 entries this year. Having previously won in '02, '04, and '06, Perkins and crew finally managed to win in an odd year. But Scott Sellers' *Donkey Jack*, the only enduring threat, battled back to at least make it close.

Ironically, after just three races, neither *Good Timin'* nor *Donkey Jack* were looking all that stellar. Their first two finishes of first and fourth, respectively, were fine, but in the next two races they

dropped to 12th and 11th, and 20th and 7th, respectively. By mid-series, Perkins had already collected 27 of his eventual 37 points, while Sellers had garnered 28 of their 42.

"We really struggled in the early races," admitted Perkins. "Having made some changes to the rig before the start, we changed them back." It made a big difference, as *Timin'* only got 10 points in the last four races. Another big factor was *Timin'*'s very talented and experienced local crew — brother Jon Perkins, David Wilson, Phil Perkins, and Tom and



Melissa Purdy.

"We were happy to win," said Perkins, "as many of the other boats in the class have stepped up their game and bought new sails."

That *Timin'* didn't continue to win was somewhat surprising because she didn't have boatspeed advantage. "Perkins' boat wasn't the fastest one out there," said Sellers. "But Chris and his crew didn't make many mistakes, and that's the key in a no-throwout series. If there had been one throwout, we'd have won, and if there had been two throwouts, Tim Russell's *Aquavit* would have won. As it worked out, our poor showing in the second race was the regatta for us. Nonetheless, my crew — we've been together for the last three Big Boat Series — still had a great time."

Another boat with three BBSs under their keel was Kristen Lane's *Brick House*. And for her, the third time was pretty charming with a third-place finish in this large and competitive fleet.

"I thought the conditions were very challenging," said Lane, one of only a handful of women skippers at this year's BBS. "My crew and I were well-trained and prepared for light and heavy winds, but not the moderate winds that were dominant." Lane says her diminutive size actually plays to advantage in heavy air, as she puts her burly main trimmer on the rail, and trims the main herself while she drives! Lane would like other women boatowners to know that she's always been well-received at the Big Boat Series, and got one of the biggest rounds of applause at the awards ceremony.

Express 37 — *Expeditious*

"What can I say? We peaked too early!" said Kame Richards of *Golden Moon* after

It's a rare Big Boat Series where someone doesn't end up bouncing off the breakwater. But few boats have managed to do it as conspicuously as 'Hazardous Waste', which hit right in front of the club. No injuries and minor damage, although pride remains in critical condition.



2007 ROLEX BIG BOAT SERIES

Yacht	Owner	Design	Yacht Club	Placings	Total
IRC CLASS - A (5 boats)					
1. <i>Samba Pa Ti</i>	John Kilroy, Jr.	B/C TP52	StFYC	1-1-2-1-3-2-2	12
2. <i>Rosebud</i>	Roger Sturgeon	STP65	Lauderdale	2-3-3-2-1-1-1	13
3. <i>Sjambok</i>	Michael Brennan	R/P 45	Storm Trysail	3-2-1-3-2-3-3	17
IRC CLASS - B (10 boats)					
1. <i>Kokopell²</i>	Lani Spund	SC 52	Royal Ocean	1-3-1-3-1-4-1	14
2. <i>Rancho Deluxe</i>	Michael Diepenbrock	Swan 45	StFYC	2-2-3-2-2-2-3	16
3. <i>Swiftsure</i>	Sy Kleinman	Schumacher 54	StFYC	6-1-2-1-3-3-2	18
IRC CLASS - C (13 boats)					
1. <i>TKO</i>	Dave Kirby	J/122	California	1-2-1-3-1-7-2	17
2. <i>White Dove</i>	Mike Garl	Beneteau 40.7	Sequoia	2-1-3-2-5-2-3	18
3. <i>Scorpio</i>	John Siegel	Wylie 42	StFYC	5-4-4-1-2-3-7	27
IRC CLASS - D (10 boats)					
1. <i>Acabar</i>	J.Y. Lendormy	Custom 45	CYC	4-1-2-1-2-1-1	12
2. <i>Tupelo Honey</i>	Gerard Sheridan	Elan 40	SBYC	1-2-1-2-1-2-3	12
3. <i>Mintaka 4</i>	Gerry Brown	Farr 11.6	BYC	2-3-5-5-3-4-2	24
1D 35 (7 boats)					
1. <i>Double Trouble</i>	Andy Costello	1D-35	CYC	5-1-1-1-5-1-1	15
2. <i>Shadow</i>	Peter Stoneberg	1D-35	StFYC	3-2-2-2-7-2-5	23
3. <i>Sweet Sensation</i>	Gary Fanger	1D-35	GGYC	4-4-7-3-3-3-3	27
SYDNEY 38 (6 boats)					
1. <i>Bustin' Loose</i>	Jeff Pulford	Sydney 38	StFYC	1-1-1-3-1-4-1	12
2. <i>Copernicus</i>	Michael Kennedy	Sydney 38	Chicago	2-2-6-1-3-3-3	20
3. <i>Howl</i>	Peter Krueger	Sydney 38	-	3-5-2-4-2-1-4	21
J/120 (9 boats)					
1. <i>Mr. Magoo</i>	Steve Madeira	J/120	StFYC	4-4-2-3-1-1-5	20
2. <i>Chance</i>	Barry Lewis	J/120	StFYC	3-1-1-1-4-5-8	23
3. <i>Dayenu</i>	Donald G. Payan	J/120	StFYC	2-5-5-2-5-3-4	26
EXPRESS 37 (10 boats)					
1. <i>Expeditious</i>	Bartz Schneider	Express 37	StFYC/SFYC	2-2-4-1-1-1-4	15
2. <i>Golden Moon</i>	Kame Richards	Express 37	EYC	1-1-1-7-4-2-2	18
3. <i>Elan</i>	Bill Reiss	Express 37	RYC	3-3-5-2-2-3-3	21
J/105 (34 boats)					
1. <i>Good Timin'</i>	Chris Perkins	J/105	StFYC	4-12-11-1-3-1-5	37
2. <i>Donkey Jack</i>	Scott Sellers	J/105	StFYC	1-20-7-3-5-2-4	42
3. <i>Brick House</i>	Kristen Lane	J/105	StFYC	13-14-8-9-8-4-3	59
4. <i>Blackhawk</i>	Scooter Simmons	J/105	SFYC	15-1-15-5-10-10-7	63
5. <i>Mojo</i>	Jeff Littfin	J/105	-	3-9-15-4-13-16-6	66

Complete results: www.stfyc.com

punctuating his three-bullet scorecard with a glaring seventh in Race Four. No big deal, according to Richards. They

simply made an unfortunate decision and got stuffed. *Golden Moon* stayed in the hunt until the bitter end, though, wowing the crowd on the St. Francis YC race deck with a photo finish in the sixth race against Bartz Schneider's *Expeditious*, the eventual class winner, and again in the final race against Michael Maloney's *Bullet*. *Golden Moon* lost both matchups by a nose, but proved once again that the venerable Express 37s — by far the oldest one design class in the regatta — still deliver thrilling, highly-competitive action.

After placing third in class in the last four BBSs, Schneider was so elated to finally take top honors that he was beaming like a mom with a newborn baby when last year's winner, Caleb Everett, showed up at the dock to award him with the fleet's perennial gag prize, a Timex.

2007 ROLEX BIG BOAT SERIES

"My crew's effort was as perfect as it gets," said Schneider as he accepted the award and etched his name on its duct tape nameplate with a Sharpie. Most of them have raced with him for more than five years — some for 20. They are tactician David James, Schneider's son Marshall, Jay Early, John Spencer, Doug Lee, Rob Hutchinson, Fritz Glasser, Chris Hackett and Paul Caturegli.

In addition to near flawless crew work, Schneider admits they were blessed with a moment of pure luck in Race Four when they emerged from behind Alcatraz right on the edge of a fresh breeze which



Give back that Timex! Above, Bartz Schneider was as surprised as anyone that the Express 37 winner got a Rolex this year (Rolex watches are awarded to winners of the six perpetual trophies, but this is the first time the Express 37 fleet has received one.) Left, duel in the sun — Kame Richards' 'Golden Moon' (18488) and Schneider's 'Expeditious' blast down the Cityfront less than a boatlength apart.

the six boats ahead of them missed. "That was the big turning point in the regatta for us," he said. But *Expeditious* didn't cement their victory until the final beat of the final race, when they cautiously squeaked by enough competitors

biggest, or the windiest, or the flashiest. But for excitement, fun, excellent race management — and superb racing — it will certainly be recalled as one of the best.

to make winning the class a mathematical certainty.

It's impressive to note that Express 37s have competed in 18 consecutive BBSs — more than any other one design fleet in the regatta's history. (The BBS also serves as their Nationals.)

And so another Rolex Big Boat Series goes into the history books. When sailors look back on the 2007 edition, they may not remember it as the

— latitude 38/rs/lc/aet/jr

Passage Yachts: Your Performance Boat Headquarters

BENETEAU FIRST 10R



- State of the art
- Farr-designed
- Hall carbon fiber rig
 - T-bulb keel
- Surprisingly comfortable
 - Easy to sail

We're proud to be the new Bay Area dealer for **ALERION EXPRESS**

- One of Carl Schumacher's most classically beautiful designs
- Active One Design fleet



Shown: Alerion 28
Also available: 20, 33 (new), 38

BENETEAU FIRST 36.7



- Affordable, multi-purpose racer/cruiser
- Well established fleet, more than 40 boats on the line for 2007 Nationals



Pt. Richmond Office
1220 Brickyard Cove Road
p: 510-236-2633
f: 510-234-0118

www.passageyachts.com
sales@passageyachts.com

Alameda Office
Marina Village
1070 Marina Village Pkwy,
Suite 101
p: 510-864-3000
f: 510-337-0565

Club Racing to Grand Prix

**WINNING
IS BETTER!**

Easom Racing and Rigging Dominates!

ROLEX BIG BOAT SERIES 2007



Acabar Winner IRC-D

***EASOM-
SUPPLIED BOATS
TROPHY IN ALL
IRC CLASSES!***

**Congratulations to all
Easom winners and all Big
Boat Series competitors.**

A FLUKE?



Kokopelli[®] Winner IRC-B

JAZZ CUP 2007

***EASOM-RIGGED BOATS FINISH
FIRST, SECOND & THIRD OVERALL!***

It's more than buying a shackle or a jib sheet... it's buying the right product properly applied.

This only comes from 35 years of experience with local and round-the-world Grand Prix racing – from the Jazz Cup to the Maxi Worlds in Sardinia!



Easom Racing and Rigging

1150 Brickyard Cove Rd. Suite B1
Point Richmond, CA 94801

(510) 232-SAIL (7245)

KEVIN'S WORLD

Who knew?

Ever since 1990, when the Glacier Bay company first opened its doors in Oakland and began marketing the first CFC-free marine refrigeration system, it's been thought of by most of us as a small but innovative Bay Area business that did one thing, but did it well. Little did we know that from the very beginning founder Kevin Alston and his crew have also been tackling a vast assortment of complex technological challenges put forth by a client list that includes Fortune 500 companies and various branches of the U.S. government.

Today, Glacier Bay is a hot property in the eyes of both venture capitalists and 'green'-minded tech writers. They predict a very bright future for this rapidly expanding firm due to its revolutionary approach to diesel-electric propulsion and a range of other products which incorporate super-efficient power management schemes.

The company created a buzz throughout the marine industry last February when The Moorings displayed its new 4300 Electric charter catamarans at the Miami Sailboat Show. Built by Robertson and Caine in South Africa, these four-cabin cats are equipped with Glacier Bay's OSSA Powerlite diesel generators, electric propulsion motors and a full compliment of other electronic components, all fully integrated into an ultra-sophisticated control and monitoring system. OSSA units will also be standard issue on a new line of Corsair 50 cats currently being built in Vietnam. They're already optional on Maine Cats, and will soon be seen on other production boats, as well as on one-off sail and

Thanks to its sealed electric drive motor — the green unit at bottom — the bilges of this Moorings 4300 Electric cat are squeaky clean.



THE MOORINGS

powerboats.

Alston explains that his outfit first made a blip on the radar of corporate America in 1990, when ozone depletion was being hotly debated in Congress. If a fledgling California company can eliminate CFCs in yacht fridges, one legislator argued, then why can't the big boys do the same in households across America? Alston was soon being asked to solve all sorts of problems involving critical thermal regulation. A memorable one was a challenge by Westinghouse to work out a way to cool a delicate sensor imbedded in the sea floor which was meant to detect nuclear launches worldwide! Alston's team successfully developed a solution, and later did R&D work for such major players in the tech world as IBM, Hewlett Packard, Northrop Grumman, NASA and DARPA — the central research and development organization for the Department of Defense. Half the insulation on the international space station, for example, was made by Glacier Bay.

From a crew of only three employees during its first decade in business, the company's new Union City headquarters now houses a staff of 86. And with more than two dozen markets identified for future growth, they're eager to hire more of the region's 'best and brightest'.

Tall, lanky and eternally enthusiastic, Alston is a classic techno-entrepreneur. He dropped out of high school and holds no advanced degrees. But what he lacks in embossed certificates, he makes



THE MOORINGS

up for with an unquenchable curiosity and an uncanny ability to think outside the box — and deliver innovative results.

While others were touting the 'wonderfulness' of electric propulsion systems which were cobbled together using



LATITUDE / ANDY

off-the-shelf diesel generators, electric motors and battery banks, Alston and his crew took a completely unique approach. Every element in their OSSA Powerlite systems — on a big yacht that might mean diesel generators, electric propulsion motors, battery chargers, refrigerators, bow thrusters, air conditioners and other appliances — are engineered to work together harmoniously at peak efficiency, while consuming a minimum of energy. At the core of the system is an ultra-'smart' central control module — the system's brain — which minutely regulates all power needs through a sophisticated CANbus wiring system.

OSSA's variable-speed DC generators are designed to produce only as much power as is required by the system at any given time. They employ a highly pressurized 'common rail injection system' similar to those used in high-end cars. But in the OSSA system, injectors are electronically controlled to insert up to five injections of fuel per stroke, yielding maximum power and fuel economy. Or, as Alston puts it, "optimizing the combustion process for the load."

The concept of 'optimizing' is, in fact, at the heart of everything Glacier Bay is doing these days. That is, every element

— THINKING OUTSIDE THE BOX



In the Union City plant, craftsmen inspect the workings of a 200-kW generator which will soon be installed on a 72-ft poweryacht.

is designed to operate at peak efficiency in any given situation, thereby using less energy and requiring much less maintenance. While demonstrating a 200-kW generator, Alston explains, "There is no maintenance schedule. It will let you know (via its electronic control board) when it is getting ready for an oil change, because it monitors its own oil quality."

A principle difference between the OSSA system (used on Moorings, Corsair and Maine catamarans) and other hybrid systems, such as those found on Lagoon's new 420 Hybrid, is that OSSA systems do not utilize large battery banks. Instead, the generator runs whenever the propulsion motors are engaged — not unlike a modern cruise ship. Although Alston acknowledges that strings of high voltage batteries can be used effectively in certain circumstances, he claims that such systems are typically less efficient, while potentially incurring higher maintenance costs. He also questions the wisdom of adding all that extra weight — especially to a multihull.

With fuel prices rising and environmental concerns mounting, more than 50 production boat manufacturers are reportedly now considering greener power plant solutions such as those of-



Founder Kevin Alston reveals the guts of an OSSA Powerlite 240-volt DC generator, which requires minimal maintenance.

fered by OSSA. Production catamarans are the obvious place to start. Instead of equipping a cat with two conventional diesel engines and a house generator (if air conditioning is desired), they can be fitted out with one generator and two electric motors for close to the same money. But the diesel-electric hardware will weigh less, take up much less space, use less fuel and, in theory, require much less maintenance.

Poweryachts of various sizes are another obvious market — including the

820 megayachts that are currently being built worldwide. Glacier Bay will soon install an integrated system of five 200-kW generators, two 800-hp propulsion motors, four 35-hp accessory motors, a DC to AC inverter, six variable-speed air conditioning units, a watermaker and various other appliances on a 72-ft semi-planing poweryacht. Compared to equipping it with conventional engines, Alston figures that if the boat is operated 2,000 hours a year — that's about 38 hours a week — the OSSA system will save an estimated 24,000 gal of diesel fuel (a value of at least \$72,000) and will keep over 500,000 lbs of CO₂ from entering the atmosphere. And, in theory, it will out-per-

form traditional diesels.

Sadly, the cost of repowering a used boat with diesel-electric propulsion doesn't pencil out very favorably on a cost/benefit basis. Unless, perhaps, you were going to completely gut all its systems — refrigeration, AC, watermaker, battery charger, etc. — and replace them with fully integrated OSSA machinery. In that case, the fuel, maintenance and space-saving benefits would definitely help you to rationalize the cost — especially if you were preparing for heavy commercial use or perhaps a world cruise.

This brings us to the question of repair. Some would argue that the complexity of all this newfangled gadgetry will lead to more maintenance headaches than on 'simpler', conventional systems. Alston responds: "The K.I.S.S. (keep it simple, stupid) principle is a cute idea for a small cruiser, but basically, it's B.S." He reminds us that the cars we all drove back in the '70s needed frequent tune-ups, muffler replacements, etc., while today's cars — even the cheapest among them — are a hundred times more complicated, yet will run virtually trouble free for 100,000 miles or more. "Technology properly applied dramatically improves efficiency," he argues, "and dramatically reduces maintenance. The only time you have a problem is when technology is improperly applied. Then it can be your worst nightmare."

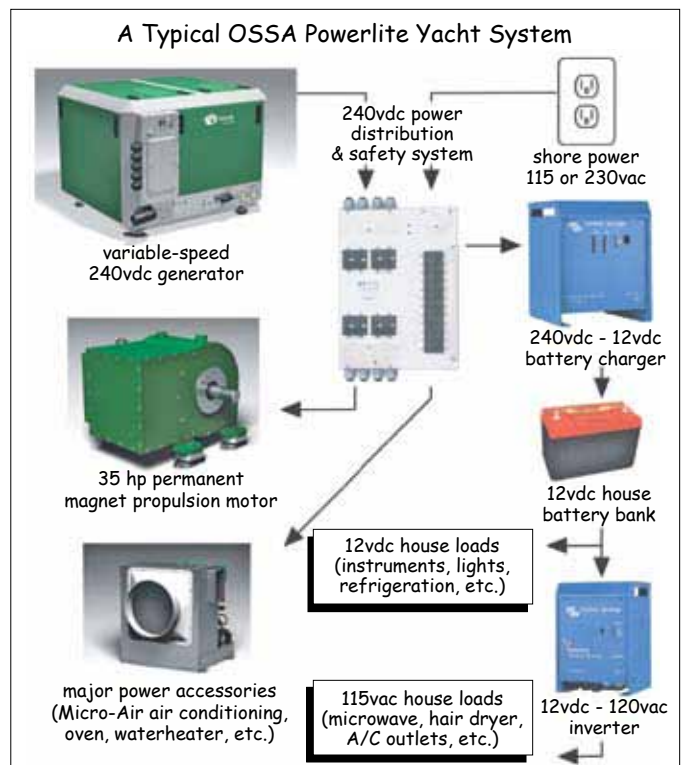

KEVIN'S WORLD

Even if we accept that OSSA's "brushless" motors need virtually no maintenance, and acknowledge that all their components have state-of-the-art self-monitoring capabilities, Murphy's law of boating dictates that everything will break down eventually. So what happens if your OSSA system craps out on the approach to Pago Pago? The system is designed to tell you which component has gone bad. If it's the control module (brain), you'd have one FedExed in and pop it into place yourself. (Glacier Bay offers a three-year "swap-out warranty" — meaning exchanged for free — on all their components.) If it's the drive motor or generator, you would have to ship it to the nearest service center for repair or have a new unit shipped to you. Five company-owned maintenance stations in locations around the world are slated to be up and running within a year. While shipping the unit may sound like a hassle, Alston points out that if you have a traditional diesel, the local Pago Pago mechanic isn't likely to be factory trained to service it, nor is he likely to have the part you need anyway. So,



LATITUDE/ANDY

These ClimaCab truck air conditioners are produced under the same roof as blood-cooling devices and ultra-quiet insulation.

regardless of which style of power plant you have, shipping parts or components will often be necessary to complete a major repair.

While interest in Glacier Bay is increasing dramatically among boaters and boatbuilders, marine systems are only one entree on the company's ever-enlarging menu of techno-savvy devices.

Inspired by recent legislation which prohibits long-haul truckers from napping along roadways with their engines on (to power their ACs), Glacier Bay has developed "no-idle truck air conditioning" units, marketed under the name ClimaCab, which run off the truck's existing batteries. The company has one foot in the medical field also. In response to the discovery that fever in the brain causes most brain damage after a stroke or other physical trauma, Glacier Bay thermal gurus have developed a fascinating device which delicately lowers the blood temperature of patients during recovery, the CoolGard 3000.

So what's next? An ultra-powerful 400-kW generator — producing enough electrical energy to power a cruise ship — is already on the drawing board, and articulating, retractable "pod drives" for sailboats are being discussed. With 17 years of problem-solving success to build on and a second truckload of venture capital soon to arrive, the sky's the limit.

— latitude/at

SUNNY * WARM * FRIENDLY

LOCH LOMOND MARINA

IN SAN RAFAEL

Completely Rebuilt Marina • Gas & Diesel Fuel Dock
Free Pump Out Station • Modern Launch Ramp
Guest Slips Available • Marine Mechanical Boat Repair
Arena Marine Supply Store • Bobby's Fo'c's'le Cafe • Loch Lomond Market

110 Loch Lomond Drive, San Rafael, CA 94901
Phone: (415) 454-7228 • Fax: (415) 454-6154
www.lochlomondmarina.com
Harbor Master – Pat Lopez • pat@lochlomondmarina.com



Factory Authorized Dealer

Serving:

- Benicia
- Glen Cove
- Napa
- Vallejo & beyond!



Don't Pass Us By...

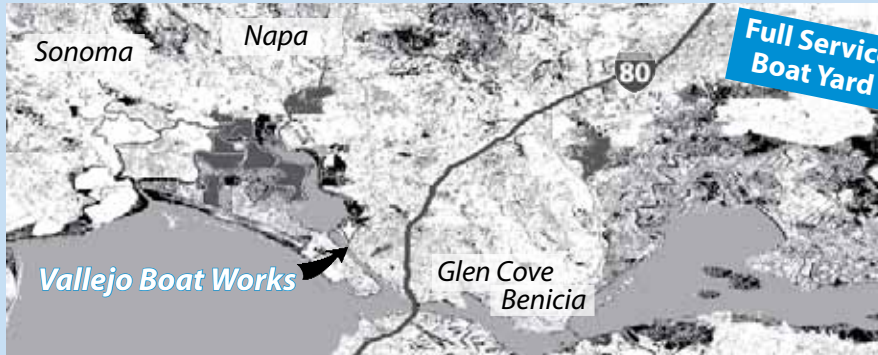

Full Service Boat Yard

The North Bay's complete marine service facility:

- Complete chandlery
- 40-ton haulout service
- Engine and drive service
- Bottom paint
- Finish paint
- Fiberglass repair
- Marine electrical

"If it's broken, we fix it."



Why Haul Your Boat Down to the Central Bay?

1 Harbor Way, Vallejo
(adjacent to the Vallejo Marina)

(707) 554-2813

www.vallejoboatworks.com

2007 Model Year Clearance Sale

limited to stock on hand

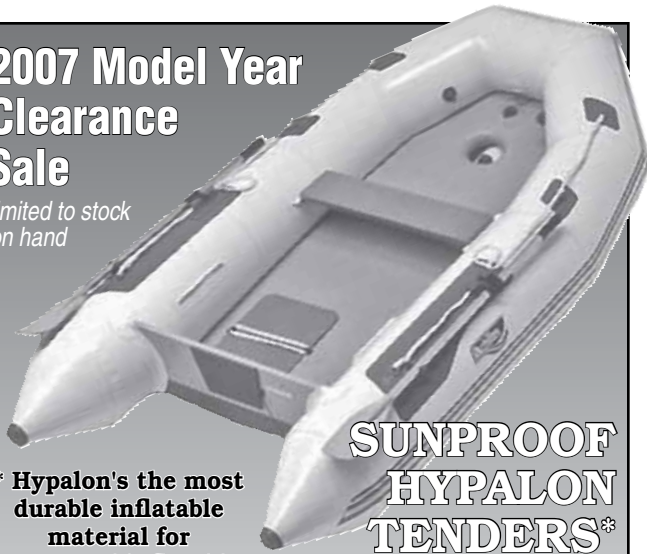

SUNPROOF HYPALON TENDERS*

by Achilles

* Hypalon's the most durable inflatable material for UV-exposed inflatables.

To learn more, call:

SAL'S INFLATABLE SERVICES, INC.

PHONE (510) 522-1824

FAX (510) 522-1064

1914 Stanford St., Alameda 94501
salsinflatables@sbcglobal.net
www.salsinflatableservices.com

Achilles Inflatable ~ In Stock & First Quality

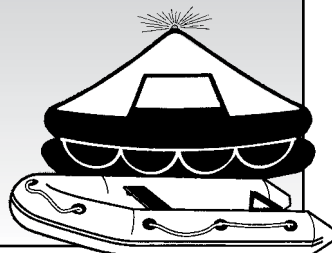

FOAM

Mattresses • Cushions FREE CUTTING!



- **Custom foam** cut to any size or shape for your bows, berths, bunks and cushions
- **Largest selection** of foam in stock extra firm to pillow soft
- **Expert** custom sewing 20 years experience, lifetime warranty
- **Quality** marine fabrics, marine vinyls, Sunbrella, canvas

10% OFF WITH THIS AD



FREE ESTIMATES



FOAM CREATIONS

ALBANY~BERKELEY

1120 Solano Avenue

(1 block above San Pablo)

(510) 526-7186

Hours: Monday-Saturday 10-6 • Sunday 11-5

SPEARFISHING

A big way to help reduce the monthly cruising costs aboard *Far Fetched*, our Beneteau Oceanis 390, is being able to provide the majority of protein we eat for free. Yes, I'm talking about fishing, but not the kind most cruisers do. I'm talking about spearfishing.

I should say right away that there is nothing wrong with rod and reel fishing. Quite a number of cruisers we talked with have lots of success with this — and so have we. On our trip down from Washington we caught a king salmon, two yellowtail, and two mahi-mahi with a rod. Not bad, but once in the Sea of Cortez our rod-and-reel luck ran cold and only a couple of bonito bothered to attach themselves to our lure — and a sea lion got one of them before we could reel it in.

If your luck hasn't been much better, then the following might be useful information.

We find a much surer way of providing fish is to dive for and spear them. Each week at least three to four of our meals came from fish caught this way. My brother Bruce is a good diver and excellent spear fisherman. I'm okay and can produce fish upon occasion. In our six months in the Sea we met many cruisers but few, if any, who even tried to spear fish. Here's my take on why.

It's easy to get discouraged if after the first few

dives you don't land a fish. And with no prior experience or coaching this is most often the case. You don't know what ter-

rain to hunt in, where the fish hang out or which fish to shoot. Without the encouragement of early success, the spear gun is often retired and eventually buried in the lazarette. Your menu doesn't include as much fresh fish, and your wallet becomes lighter. Yes the equipment does cost something, but properly maintained, good equipment will last a dozen or more years, and the satisfaction of adding fresh fish to your menu, almost at your whim and at the remotest anchorages is, as they say, priceless!

Equipment

First you need the right equipment. The obvious mask, snorkel, and fins for starters. Remember to get spare straps for the fins and mask and make sure everything fits. Add a wetsuit of proper thickness for the water temperature and a weight belt. The weight belt should be heavy enough to keep you neutral or 'weightless' at the depth you wish to hunt. Most of the fish we hunt are at 10 to 25 feet, so we adjust our weight for these depths. Be sure you know how to release the weight belt if you get into trouble.

Since the Sea's water temperature is cool in the winter months, this may

mean a full wetsuit with hood, boots, and gloves. My preference is to use the 'layered' approach. I have a full-length 3-mm surf suit, and a thicker, 7-mm 'torso'

suit that I can put over it. With these two items, I can handle any water temperature by using only one or both suits.

We do not use scuba tanks. They render you slow and heavy, and the bubbles scare away the fish. Which leads to an important tip. If you haven't spent much time snorkel-

ing, become familiar with your equipment *before* attempting to use a spear gun. Spend several days just practicing diving, preferably in calm water with minimal surge. Enjoy the underwater sights and start to get familiar with the fish and their habitat. Only when you feel



comfortable clearing your ears, moving around underwater, and clearing your snorkel upon surfacing, should you take up your spear gun.

Now on to the hunting equipment. Most cruisers buy a spear gun from a salesman in a dive shop. If the salesman has actually speared fish, then take his advice but strongly consider the following: the underwater terrain in the Sea is as varied as the species of fish. No one gun can do it all.

We have four different spear guns onboard and will most likely buy another for next year. Our spear guns vary from a very short 24" gun for use in tight areas, usually small caves and crevices, to a 48" spear gun for use in open water. The other two guns are 30"



STEVE ALBERT

Pictures of nothing? Au contraire. If you're a spearfisherman, these scenes are worth 1,000 words — topography like this indicates happy hunting grounds.

dives you don't land a fish. And with no prior experience or coaching this is most often the case. You don't know what ter-



extra batteries.

Take care of your equipment. Rinse the spear guns in fresh water after each use and lubricate the mechanisms from time to time.

We do not have a reel setup for any of our guns. A reel setup helps with the larger fish that are often taken in deeper water as it allows you to get to the surface to play the fish. We don't use one because we don't shoot fish over 20 pounds. Most of our fish are around 10 pounds and taken near the surface. This is enough meat for a meal or two. If you can get 10 to 15 pounds of fish each week, you'll eat well.

Finding Fish

There are two important tenets to be aware of when spearfishing. First, fish are intelligent creatures. They know you are hunting them. They are also curious, and you can use this to your advantage. Second, the terrain you choose to hunt in is very important. Choose wrong and you won't see much. Choose wisely and you'll have dinner.

Fish like cover. This means a rocky area, preferably with caves. So what we look for, even before we pull into an anchorage (or when we take our tender around an area), are portions of rock walls that have fallen into the water, and which you can see either at or close to the surface. The larger the size of the rocks the better, as the bigger the caves that they form. Car-size rocks are ideal. Do not waste your time on areas off a sandy beach or with few rocks and caves. You'll see some colorful fish but nothing for your dinner plate. Again, you want piles of rocks that have formed caves such that you can stick your head and upper torso, or whole body, into. This is the habitat that the good eating fish, such as pargo and grouper, like to hang out in.

Almost all of our diving is done within 50 feet of shore and in water less than 25-feet deep. Some of the larger fish we

Kelston McGuire and 'Skooch' score the main ingredient for fish tacos. At 7, Kelston is already an accomplished spearfisherman.

and 36". These mid-length guns are good all-purpose guns but don't match the long and short guns in their particular environments. The brands of spear guns we have are Mare, a short pneumatic gun good in tight places; JBL, a good dollar value manufacturer; and AB Biller's Sea Hornet. Another good high-end brand is Riffe. Does the typical cruiser need four guns? Probably not. But I would recommend at least two for anyone seriously considering taking up spearfishing: one in the 24" to 30" range and the other over 48".

Along with the spear guns get spares: an extra shaft, spear tips, bands (or the

makings of bands, which consists of surgical tubing and wishbones) and the attachment line, which should have a rubber snubber incorporated in it. If you use your gun two times a week you will go through two or three sets of bands in

*Fish are intelligent creatures.
They know when you are hunting them.
They are also curious . . .*

six months, and a spear tip every month or two depending on how many rocks you kill. Loctite the tip to the shaft. Also it's a good idea to pick up an underwater dive light. It makes it easier to see back into caves, where many of the fish you want on your plate reside. And don't forget

take are within 10 feet of shore and in less than 10 feet of water.

Hunting

Hunting falls into three categories; caving, stalking, and letting the fish come to you.

MIKE MCGUIRE

SPEARFISHING

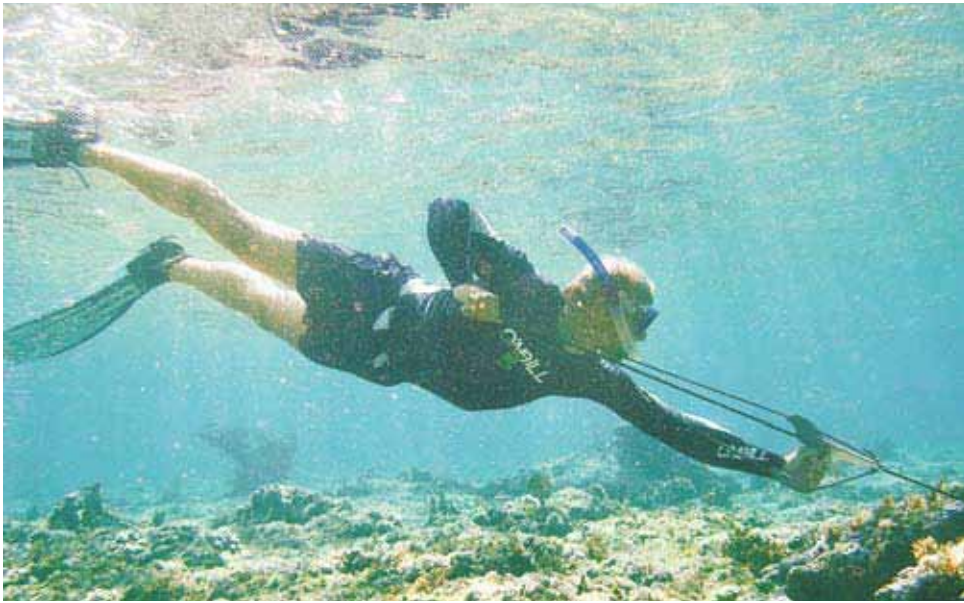

Caving — Locate a cave and swim into its mouth. Have your short or medium length spear gun ready. Explore the cave using your flashlight. Having the flashlight is important, as otherwise it takes too much 'bottom time' for your eyes to adjust to the lower light. Most fish that dwell in a cave will hesitate several seconds before moving back or trying to swim around you. That's when you need to take your shot, so be ready!

A word about the range of the spear gun is in order here. If the fish is farther away than twice the length of the spear shaft, your odds of making the shot drop. Try to get closer if possible. If you are looking straight at the fish, aim for the mouth. Looking down on the fish, aim for a point just behind the head, and if broadside, aim for just behind the gills. On the broadside shot, the fish may move with the discharge of the gun and the spear will drop several inches if at maximum range. If you anticipate that, or if the fish is already swimming, adjust your aim by leading the fish and aiming a bit high.

Stalking — For those of us who don't like dark and confined places (I fall into this category), there is stalking. Again, you want a rocky area with caves and ledges. The fish that hang out in the caves come out for feeding and to check out what's happening. If they see you first, which is almost always a certainty if you are swimming in the open, they duck back into their cave. The idea with this method is to use the rocks for cover and screening whenever possible. I like to find rocks or ledges that are within two to three feet of the surface and slowly work my way over the top to

Spearfishing 'rigs' come in all sizes and shapes, from guns to slings to (above) slingshots. Choose your weapons wisely (and treat them like weapons!) and you could add a whole new dimension to enjoying the ocean's bounty.

view what is on the bottom on the other side. Move slowly, breathe softly (if using the snorkel), and don't let the spear gun or other equipment bang on the rocks. Also keep the tip of the spear gun just in front of your head. If you hold the spear gun too far forward — again, the fish will see it and depart before you see them. With luck you'll be looking down on a nice fish that hasn't yet seen you. While this method is not as productive as the cave method, with some patience it can produce nice fish. On one dive last season, I speared both a 10-pound and a 20-pound pargo within half an hour by working over the tops of rocks. These two fish fed nine cruisers at the beach barbecue that night.

Let them come to you — Don't you

see a good number of fish hanging out down below. Work your way down to a rock outcropping or other feature you can use to stabilize yourself. Find a slot to wedge in if possible. Hold still and look away from fish that approach. Track them out of the corner of your eyes. (Like people, many fish get nervous when you look straight at them.) Have your spear gun aimed in the direction of the anticipated approach. Now the waiting begins. Depending on how long you can hold your breath, the fish will come to check you out. The longer you wait, the bigger the fish that will appear. Remember to save some breath to play a speared fish, and don't tackle a large fish without the proper gun and tackle. Yellowtail can be taken this way: extremely good eating.

Safety

Remember that a spear gun is a dangerous weapon. We load our spear guns only after entering the water — and away from the tender — and unload them before we approach the tender upon our return. As with a 'real' gun, never point a spear gun at yourself or anyone else. (For this reason we also hunt away from each other.) Always unload a spear gun before throwing it into your dinghy or onto a boat. If the spear can pierce a fish underwater, it can certainly go through a dinghy, and can seriously injure or kill you. Even a spear that flies to the end of its tether, or breaks its tether, can be very dangerous. Also, be sure you understand and avoid behavior that can lead to "shallow water blackout."

Be Realistic

Don't expect instant success. Like any new skill, spearfishing requires practice and perseverance. Even if you don't

Almost all our diving is done within 50 feet of shore and in water less than 25 feet deep.

wish it were this easy? Well, if you can hold your breath for 60 to 90 seconds, it can happen. Larger fish tend to be less afraid and more curious. You just have to give them time to get comfortable with your presence in their domain. This also means you will do best down in the 15- to 25-ft depth range. My brother Bruce uses this method to great effect.

Find a rock dropoff where you can

catch fish for awhile, the more you keep at it, the more you will start to develop a feel for where the fish are, the type of fish to spear, and how to get close enough to spear them. Any good book on identifying the fish of Baja — with pictures — will be a big help. Using this book, ask other cruisers, dive shop staff, and Mexican fishermen what they take.

On the other end of the scale, you may

find that you are a natural. Using only the advice you've just read, our crew-member Sheila Brooke, on her second hunt, took a fish with a pole spear — a feat not even Bruce has accomplished. Randy Ramirez of *Dulcinea*, who buddy-boated with us for several months after the 2006 Baja Ha-Ha, also took two nice fish after some minimal coaching.

Stay Legal

A quick word on Mexican fishing regulations. As of when this was written, you'll need a license for each crew-member, and a license for the boat, and another license for your tender. The licenses are good for a year and can be obtained by mail or through the Internet before departing for Mexico. I believe the only places you cannot spearfish in the Sea of Cortez are in the National Park off of Loreto, and the marine preserve close to La Paz, but like all regulations, these are subject to change so be sure to check with the local officials. The following

website is a good resource that explains the fishing regulations, costs involved, and how to obtain the license: www.bajabound.com/before/permits/fishing.asp.

If All Else Fails

Okay, you've tried spearfishing and all you ever caught was a bunch of guff from the crew about your lack of prowess. Your attempt to fish with a pole or trolling line are equally unproductive. Not to worry — There still is a way to get fresh fish. The only gear you'll need with this method are 2-liter bottles of Pepsi when you provision. Then, when you anchor near a

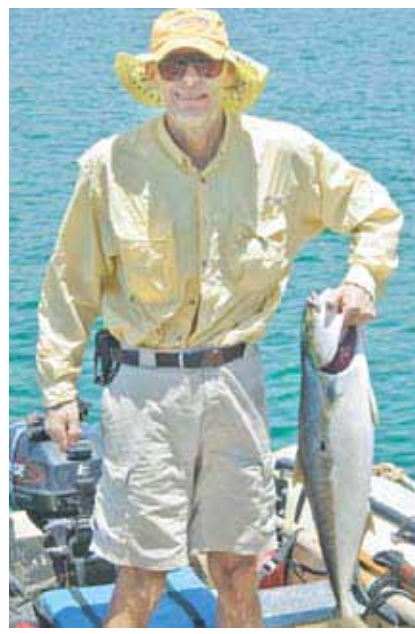

STEVE ALBERT

'Far Fetch's Bruce Albert with dinner.

remote Mexican fishing village or come upon a Mexican fishing boat, barter one of the Pepsi bottles for a nice fish or a dozen chocolates (clams). We've done this several times and you always get your 'Pepsi's worth'. It seems that Pepsi is the favored drink of the fishermen, and they run out early on their fishing excursions. So you're in a good bartering position if there isn't a store nearby. They want the Pepsi and you want fresh fish. Everyone wins!

Finally, if you run into *Far Fetched* this coming year in Mexico, don't hesitate to stop by with any questions.

— **steve albert**

MARITIME INSTITUTE



Commitment

Offer the best and most practical instruction for mariners!

We assist our students at every step to see that, not only are they prepared to pass the USCG test, but, more importantly that they're more likely to retain and use what we've covered. A well prepared mariner will be a safer mariner.

Some schools are offering a barebones course to get a student through the exam; a number of students won't pass the test and there won't be anyone there to tutor them to understand and to retest and pass what was missed. Even though 98% of our students pass the exam on their first try, as a matter of principle, we provide the additional where it's needed and at no additional cost.

For over 30 years we have built a reputation for offering the very best mariner's instruction available, anywhere. Give us a try and find out why.

CALL TOLL FREE 888-262-8020

Visit our website for more information.

www.MaritimeInstitute.com

CAPTAIN'S LICENSE • RADAR • RADIO • NAVIGATION • SAFETY

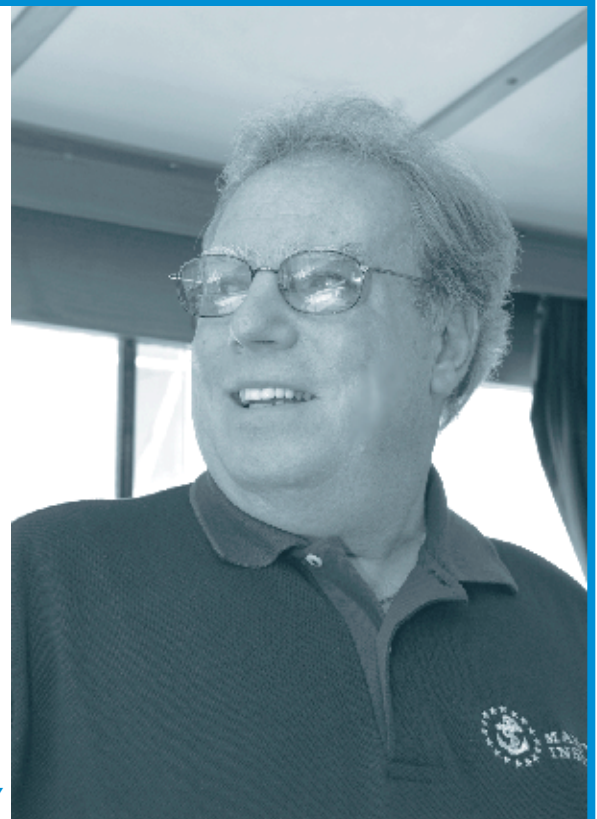

EYE ON THE BAY

PHOTOS LATTITUDE / JR. LADONNA, LINDSAY



Countdown to fall — Clockwise from right, 'Magnum 44' unfurls the big guns; 'Andre' is a giant compared to the little boat in the background; summer fog or fall clouds?; "Goodbye summer — see ya next year!"



— GOODBYE TO SUMMER

— **S**ummer may have officially ended last month, but we'll get to enjoy summer's 'longer' days until November 4, when Daylight Saving Time ends.

Think what you will about everything else President Bush has done — but give him credit for signing the Energy Policy Act of 2005, extending DST by about four weeks.

Whether DST really has a positive effect on energy savings is beyond the realm of mere sailing journalists, but what's been proven beyond a shadow of a doubt is that it allows sailors an extra precious hour after work to get out and enjoy the Bay.

If all of your 'extra' hours this summer have been filled with soccer games and playdates, now that school's back in session, why not have a playdate of your own — on your boat? If the end of September was any indicator, you'll have plenty of the warm stuff to enjoy it.

— **latitude 38** / *ld*



IDIOT'S GUIDE

Despite several advances in offshore voice communications such as satphones, marine single sideband (SSB) isn't going away anytime soon. That's because SSB radio, unlike satphones, allows an unlimited number of people to listen in to a transmission at the same time.

As such, SSB radio is the only way to go for the various regional cruising

Radio signals within the SSB shortwave spectrum refract off the ionosphere and come back to earth hundreds to thousands of miles away without the need for communication satellites and/or ground stations.

nets, such as the Baja, Sonrisa, Chubasco and Southbound nets. It means, for example, that when Don Anderson of *Summer Passage* transmits his latest weather forecast, an unlimited number of people can listen in at once. And when someone has a question about the forecast, everyone can hear the question and Don's response.

Marine SSB is also perfect for cruising events such as the Baja Ha-Ha, the Caribbean 1500 and the Atlantic Rally for Cruisers. "While the Ha-Ha doesn't require SSB radio," advises the Grand Poobah of that event, "most boats do have them. They are good for safety — but fun, too. The folks with SSB radios are able to actively participate in all the roll calls, weather and fishing reports, and other fleet news. Over a period of nearly two weeks, personalities develop over the radio, and an even greater sense of community is established."

In racing events such as the Pacific Cup, the TransPac and next year's revived Tahiti Race — where SSB is required of all entries — it offers more than just straight communication. "Thanks to marine SSB, our 1700 hour reports and discussions maintain the racing camaraderie and fun," comments Jack McGuire, KG6CJN, Communications Chairman of next year's Pacific Cup race from San Francisco to Hawaii.

Although not the subject of this article, the other significant benefit of SSB radios is that they, when used with a Pactor modem and SailMail, allow for the transmission and reception of short emails while offshore.

Licensing

You don't need to pass a Ham radio operator's test to operate marine SSB. All that's required is a valid Ship Station license and a lifetime Restricted Radiotelephone Operator's permit. No testing required! The Ship Station license is good for 10 years and is non-transferable. If

you're good at dealing with government online forms, you can apply for a license yourself at <http://wireless.fcc.gov/>. If you're not so good at it, or don't want to take the time, my lovely wife Suzie will be happy to help for a fee: (714) 549-5000.

How is Ham (amateur radio) different than SSB radio? If you're new to long distance marine radio, I suggest not even worrying about it. Although I run the Radio School and some of the income comes from teaching students how to use Ham radio and pass the test, I generally discourage new SSB operators from taking that step right away. Get the no-test

might consider eventually moving up to Ham status. But generally speaking, it's really only for serious radio buffs.

By the way, there is nothing to prevent folks with SSB radios from listening on Ham frequencies, and indeed, there are some helpful weather broadcasts on Ham-only frequencies. If you're new to SSB radio and worried that you might accidentally stumble onto a Ham-only frequency, start transmitting, and really piss off the 'radio police', fear not. SSB radios that are capable of working Ham frequencies come 'locked' from the factory. Some can only be unlocked using software, while others can be unlocked by just pressing three keys at the same time. In cases of genuine emergencies, Ham frequencies can be used even by people who don't have a license.

How Far On What Bands?

A marine SSB system operates on a marine radio spectrum called 'shortwave', medium frequency and high frequency — 2 MHz-26 MHz. This radio spectrum is shared with hundreds of other radio users such as shortwave broadcasts, Ham radio, FEMA, the American Red Cross and long-range aircraft.

Radio signals within the SSB shortwave spectrum refract off the ionosphere and come back to earth hundreds to thousands of miles away without the



In the realm of cruising, an SSB radio is a lifeline, an email gateway and a hub of friendly conversation, like an old-fashioned party line.

license for SSB radio, become familiar with the procedures and protocols, and use it for a few months. If you find that you're one of the very few cruisers who talks on the radio so much that SSB frequencies aren't adequate, then look into Ham radio. Or, if you're going to the South Pacific, where there is lots more traffic on ship-to-ship channels, you

need for communication satellites and/or ground stations. Each marine SSB radio frequency band has a very predictable skywave bounce 'bulls-eye'. If you choose a band that's too high, your signal will skip over the other station. If you choose a frequency that's too low, your signal won't go far enough to reach the other station.

The following is a good guide for

choosing the band of frequencies that will target your first skywave bounce:

2 MHz	200-400 miles
4 MHz	400-600 miles
6 MHz	600-1200 miles
8 MHz	800-1600 miles
12 MHz	1200-2400 miles
16 MHz	1600-3200 miles
22 MHz	2200-4000 miles plus
26 MHz	unpredictable during our solar cycle minimum

Pop Quiz #1: You are in San Francisco and you want to talk with your buddy who is on his boat 1,200 miles away in Cabo San Lucas. Which band on marine SSB might you choose?

Answer: Because 4, 6, and 8 MHz would likely fall short on the first radio signal bounce, 12 MHz and 16 MHz would likely be your best choices.

The thing that usually drives new SSB operators nuts — and I know that it still irritates the Grand Poobah of the Ha-Ha — is that SSB radio frequency/channels are so different from VHF, FM, television and almost every other kind of channel. On VHF, for example, channel 72 is channel 72. On television, channel 7 is channel 7. What could be more simple?

Certainly not SSB radio. Get this: while 4146 is always 4146 on SSB, it's also known as 4A, and sometimes the designator 4-1. In addition, depending on the individual radio, it's often channel 35 or channel 77, but could also be some other channel. That's right, depending on what radio you bought and when, and who might have customized the user channels, channel 35 and channel 77 may or may not be 4146 and vice versa. And, of course, it might also be channel 63 or 147 — or a bunch of other channels.

The most sure way to get to 4146 is to just tune to 4146. The problem is that you may have to do a lot of knob turning, which gets to be annoying. In order to eliminate unnecessary wrist injuries from knob turning, some manufacturers 'channelized' the more popular frequencies. That is, they assigned specific channels to specific frequencies. For example, the Icom SSB radios of several years ago assigned channel 35 to frequency 4146 (aka 4A and 4-1). That was all well and good. Unfortunately, in later radios they

decided to assign channel 77 to 4146 (aka 4A and 4-1). In addition, some retailers created custom 'user channel' packages, which gave yet another channel designation to 4146.

How did it all come to this? SSB operators used to have to spin the frequency knob like crazy to find anyone because there are more than 1,000 SSB frequencies — only a very few of which will ultimately be of interest to you. (More on that later.) As a result, most modern marine SSB transceivers — a fancy name for a combined transmitter and receiver in one black box — have nearly 700 pre-stored duplex channels — a channel simply being a specific frequency designated as a channel for easier access. After all, what's easier, dialing through 1,000+ frequencies or 700 channels?

Nonetheless, you could spin your SSB channel dial all day long and you'd probably still hear nothing — except for WLO, the excellent radiotelephone station located in Mobile, Alabama. If you want to pick up something, look for on-the-hour weather and traffic reports on the following International Telecommunications

Union (ITU) three- and four-digit designators: 405, 417, 805, 824, 830, 1209, 1212, 1226, 1607, 1624, 1641, 1807, 2237 and 2503. If you punch in 1607 on the hour, you'll get traffic lists and weather broadcasts from powerful WLO. The U.S. Coast Guard also broadcasts voice weather reports on ITU channels 424, 601, 816, 1205, and 1625.

Because SSB radios are more complicated than VHF radios, you might initially have a little trouble punching in all the three- and four-digit ITU channels and/or the actual frequencies. Maybe I can help.

ICOM America, Furuno, and SEA are the last remaining SSB manufacturers, and of the three, ICOM is the undisputed leader when it comes to equipping recreational vessels with marine SSB gear. To assist North American sailors in more easily calling up relevant ship-to-ship, Coast Guard, weather facsimile, Ham and marine telephone stations, they have pre-programmed 160 "favorite channels" — channels 1 through 160 — into a memory circuit titled 'User Channels'. These channels begin with the informal

Latitude 38's Easy Guide to Mexico Nets Baja California & Mainland Mexico

Daylight Savings Time Schedule (Summer Time)

Time				Latest ICOM Channel	Freq kHz Pri / Sec	Upper/Lower Sideband	Net Name
UTC (GMT)	PDT W. Coast US	MDT Cabo, LAP	CDT PVR, ACA				
*** Marine SSB Nets ***							
0:30	17:30	18:30	19:30	92	6224	USB	Southbound Net
14:00	7:00	8:00	9:00	105	8122/8116	USB	Amigo Net
N/A	N/A	N/A	N/A	95	6516	USB	Bluewater Net
*** Listen-Only Ham Nets ***							
14:30	7:30	8:30	9:30	149	7294	LSB	Chubasco Net*
15:00	8:00	9:00	10:00	141	7238	LSB	Baja Net
19:00	12:00	13:00	14:00	156	14340	USB	Manana Net*
19:00	12:00	13:00	14:00	151	14300	USB	Pacific Seafarer Net

* NOTE: Net warm-up and coordination sessions frequently begin prior to the published net opening time.

Standard Time Schedule (Winter Time)

Time				Latest ICOM Channel	Freq kHz Pri / Sec	Upper/Lower Sideband	Net Name
UTC (GMT)	PDT W. Coast US	MDT Cabo, LAP	CDT PVR, ACA				
*** Marine SSB Nets ***							
0:30	16:30	17:30	18:30	92	6224	USB	Southbound Net
14:00	6:00	7:00	8:00	105	8122/8116	USB	Amigo Net
N/A	N/A	N/A	N/A	95	6516	USB	Bluewater Net
*** Listen-Only Ham Nets ***							
15:30	7:30	8:30	9:30	149	7294	LSB	Chubasco Net*
16:00	8:00	9:00	10:00	141	7238	LSB	Baja Net
19:00	11:00	12:00	13:00	156	14340	USB	Manana Net*
19:00	11:00	12:00	13:00	151	14300	USB	Pacific Seafarer Net

* NOTE: Net warm-up and coordination sessions frequently begin prior to the published net opening time.

Time adapted from Docksideradio: www.docksideradio.com

IDIOT'S GUIDE

designator #1, and end with #100 — unless, of course, you have the new ICOM 802, which has user channels #1 to #160.

For example, if you have an Icom 802 and tune to Channel 77, you'll find that you'll be on frequency 4146 (aka 4A). And if you tune to Channel 118 on an 802, you'll find yourself on frequency 3968, which is home to the Sonrisa Net at 7:30 a.m. Pacific Time in the winter. It will even show 'Sonrisa Net' on your screen, even though the Sonrisa Net only uses that frequency a few hours each day.

Your radio will no doubt also have a toggle for 'channel/frequency'. As you toggle it, the display will switch back and forth from, say frequency 4146 to Channel 77 — assuming, of course, that 77 has been assigned to 4146 on your particular radio.

Take this opportunity to run all the user channels on your radio, and make a list of what frequencies/stations they

refer to. As mentioned, if you have a newer Icom 802, it's very likely, but not certain, that you have the same channel/frequency combinations as owners of other new Icom 802s. But if you have an older Icom model, or perhaps had a custom user channel package put into your 802, I'd recommend you have an authorized Icom dealer come down and give you the most recent user channel package. All he does is plug his computer

Latitude 38's favorite SSB channels that I've compiled to help you better understand that each channel has a specific purpose. You'll notice there aren't 700 of them. That's because you can only use 33 primary channels. And for cruisers in California and Mexico, you'll almost exclusively be using just five of them: 4A, 4B, 4C, 8A and 8B. That's not many, but you'll rarely have trouble finding an open channel. (There are an additional 49 secondary channel/frequencies on the 4 MHz and 8 MHz bands that you can use if they aren't being used at the time, but if you're just starting out, you don't need that additional confusion.)

The main thing to do is play with your user channel/frequency combinations so you become familiar with them. It won't take long. If you find that your channels are out of sync with most other folks' SSB radios, you might want to change yours to match theirs. Depending on how technical you are,

For cruisers in California and Mexico, you'll almost exclusively be using just five of them: 4A, 4B, 4C, 8A and 8B.

into the front of your radio and download the new stuff. It shouldn't take more than 15 minutes, and will synch you with the majority of other SSB radios.

If you look at the sidebar, you'll see

It's Time to "Fuel-Proof" Your Boat!

FilterBOSS

"It's like having an onboard fuel mechanic"

A dual filter controller with a built in vacuum pressure gauge for monitoring the online filter, a built in fuel pump for easy engine bleeding and onboard fuel polishing, along with an early warning panel to let you know when the filter is clogging.

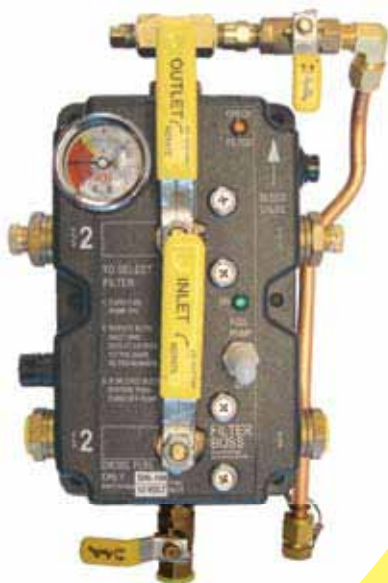

The All New FuelBOSS Onboard Fuel Cleaning/Transfer System

Designed to be installed into the existing engine fuel feed and return lines. An easy way to deal with the continuous problem of contaminated fuel. Available in two models operating at 60 or 90 GPH.



FUEL BOOST PUMP

Supplies sufficient fuel pressure and flow for servicing and bleeding. Acts as a back up if your engine lift pump fails and is not leaking.

FUEL MANIFOLD SYSTEMS

Aluminum and brass housing available.



FilterBOSS
"Don't Leave Shore Without It."

Visit our website
or call us for
more details!

www.KTISYSTEMS.com (800) 336-0315 / Fax (413) 569-6911 / Filterboss@ktisystems.com

you may or may not need assistance.

Calling For Help Over The SSB

In addition, there are six Coast Guard Global Maritime Distress and Safety System (GMDSS) channel/frequencies: 2182, the distress channel; 4125 (4S); 6215 (6S); 8291 (8S), 12,290 (12S); 16,420 (16S). The Coast Guard or other international rescue agencies monitor them 24 hours a day. U.S. Coast Guard monitors out of Hawaii, Guam, Alaska, San Francisco, New Orleans, Miami and Norfolk.

Warning! Remember, different bands have different ranges. If you make an emergency call on 2182 when you're half-way between Mexico and the Marquesas, it's very unlikely anybody is going to hear you. If you check the earlier chart, you'll see that you'd actually want to transmit on 12,290 (12S) where the range would be 1,200 to 2,400 miles.

Checking Your SSB Reception And Transmission

OK, you're getting some meaning-

Latitude 38's Favorite SSB Channels

When cruising Mexico, these are the only channels you'll really need for calling ship-to-ship or ship-to-California.

Channel Designator	Latest ICOM Downloadable Channel	Frequency kHz
4A.....	77.....	4146 kHz USB
4B.....	78.....	4149 kHz USB
8A.....	97.....	8294 kHz USB
8B.....	98.....	8297 kHz USB

ful reception as you dial around the channels, but you'll probably still be wondering if your SSB is working as it should. One way to begin to find out is by trying to pick up the time signals at 10 and 15 MHz and WWV, which provide a continuous signal for a ready reference. If you're still at the dock and plugged in, you may find that turning off the shorepower battery charger will make a huge difference in your reception. Ditto for the refrigeration and any florescent lights or inverters that might be turned on.

If you're unsure if you're transmitting, you can tell a lot by looking at the

LCD display on the face of your radio. First, push the 'TUNE' button, at which point the radio should briefly transmit a low power signal to tune the automatic antenna coupler. Do this on any 6 MHz channel as long as there is no traffic on it. The word 'TUNE' should flash a couple of times on the LCD screen, and then stay up on the screen when the radio cycles back to receive. Still see the word 'TUNE'? This is good. However, if the word 'THRU' comes up, or 'HI SWR', you've got problems. At that point it's probably time to bring in a NMEA-qualified marine SSB specialist to see what's wrong between your radio and your tuner.

Assuming you do get 'TUNE', it's time to pick up the mic and try a short transmission. After doublechecking that the frequency is clear, key the mic, and speak directly into it saying "FOOO-OUUUUR." The mic should be touching your lips when you do this. If the following things happen, it suggests that your transmission is good and powerful:

1) The LCD bar graph goes full scale.



The VIKING advantage

VIKING RescYou Pro™

- Your guarantee for ultimate safety

- Available in 4, 6, 8 person capacity
- Equipped with inflatable double floor
- Full Offshore (E-type) equipment Pack (Optional ISO Pack 1, Pack 2 or Solas B)
- Available in valise or low profile container with stainless steel cradle for rail or deck mount
- Worldwide servicing - over 300 USCG/SOLAS approved service facilities

Hailed Market's Best
by Independent Sources
• Three-Year Service
Intervals

U.S. Sail Boat Show
Power Boat Show
Ft. Lauderdale Int'l Boat Show

Land Space #10
Land Space #42
Booth #M18



VIKING LIFE-SAVING EQUIPMENT
(America), Inc.

Please contact our local Viking dealers:

Sal's Inflatable Services	Alameda	(510) 522-1824
Coast Marine & Industrial Supply	San Francisco	(415) 673-1923
Oceans West Marine	San Diego	(619) 544-1900
Viking Life-Saving Equipment	Long Beach	(305) 614-5800



IDIOT'S GUIDE

- 2) Your cabin lights dim slightly.
3) The instrument indicator lamps glow.
4) The bilge alarm squeaks.
5) The house battery drops about a half volt.
- It is perfectly normal for instrument panel lights to glow and bilge alarms to squeak when a powerful 100 watts are

Using an SSB in an Emergency

Marine SSB has been allocated hundreds of international channels, some of which are closely guarded by the U.S. Coast Guard and worldwide rescue agencies. They are prepared to act immediately on any received Mayday or call for medical assistance. The Coast Guard maintains 24/7 distress radio guards on the following frequency bands:

2.182 MHz	good for only close-in distress calls
4.125 MHz	400-800 miles
6.215 MHz	600-1200 miles
8.291 MHz	800-1600 miles
12.290 MHz	1200-2400 miles
16.420 MHz	1600-3200 miles

Emergency example: You're sailing from Zihuatanejo to the Marquesas, a crossing of roughly 2,800 miles. About halfway across a thruhull pops off with water gushing in fast. Could you raise the Coast Guard on 2182 kHz? Nope. Too low a frequency. You're best bet would be to switch to 12 Safety, 12,290 kHz, and call for any Coast Guard station. It's likely that Hawaii and Point Reyes would respond, maybe even Guam, to help note your position and situation. If you needed to bail out, they could get on their GMDSS Inmarsat system and hail the closest ship in your area to talk you out of stepping off a perfectly good sailboat, and instead just plug the damn leak! In any case, it's nice to have someone know where you are when emergencies arise.

coming out of your marine SSB. But most important, doublecheck that the LCD transmit indicator shoots across the screen when you say a very loud "FFOOUUUUR".

A potentially more dangerous way to test the transmit power output is with a small florescent tube at night. Ask your first mate to hold the glass tube against the insulated backstay antenna or the big white whip. *Caution! Be sure they don't touch the backstay with their fingers or other parts of their body, as this could result in a nasty burn or worse.* Say the magic word, "FFOOUUUUR" once again, and the tube should instantly light up. The glass must actually be touching the radiating antenna or antenna lead-in single wire for this to happen.

If, when you say the magic word "FFOOUUUUR," the cabin lights dim, the bow head flushes, numerous bilge alarms go off, and the florescent tube lights up, chances are excellent that you're putting out 100 watts. But are they clear watts? Only a radio test with another SSB user can determine that, so ask someone else in the marina to dial in

NOMAR® BUMPERS

Manufactured By:

HOLMES MARINE SPECIALTIES

Meeting Your Docking Needs



- Imagine NOT having the hassle of taking your fenders ON and OFF every time you go in and out of your slip.
- Are you tired of having your fenders constantly riding up on the docks, getting your hull marked up or worse?
- Paying for expensive hull rub-outs or repairs? • Big boat, small slip? • Do you singlehand your vessel?
- Tired of having your spouse or friends jumping off a moving boat onto a shaky dock?

We have great news for you! HMS is now manufacturing a new style of Dock Bumper.

These new NON-MARRING bumpers mount on your dock, making hassling with fenders a thing of the past. Not only is the new style of bumper extremely durable, it is also removable so you can take it with you if you move. Now available in three mounting formats to help protect your investment.

***For more information and a FREE Price Quote please call us at (800) 501-0607
or visit us on the Internet at www.holmesms.com***

TO MARINE SSB

a common ship-to-ship channel, such as 6224, and run your radio check. This will be a good test for a nice, clean signal.

If your test partner reports that your sound was garbled and you've just added a new email modem to your rig, temporarily disconnect the wire going from the back of your marine SSB to the computer. If your voice now sounds clear, these additional wires are the problem. Snap-on filter chokes are available from your local marine electronics specialist that may resolve the garbled voice problem.

A good test for the range of your radio is with me! I'm happy to offer *Latitude* readers free, on-the-air radio checks on an appropriate SSB frequency that will agree with the approximate range between your station and mine, here in the Newport Beach area. If your boat is in the Bay Area, we will likely use 8 MHz. If you are local, we'll go with 4 MHz, and if you're down at Cabo, we'll probably choose 12 MHz. Call me on the phone at (714) 549-5000 weekdays and we'll find a nice quiet channel for our radio check.

Another great way to test your marine

SSB transmit-and-receive capability is with weather guru Don Anderson on his marine SSB Amigo Net. He begins at daybreak, at 1415 hours Zulu (UTC) on 8.122.0 MHz, upper sideband. If you have the latest frequency load from Icom America, it's already stored in memory as channel 105. If you don't find it in memory, you will need to break out the instruction book and learn how to program a new frequency to be stored in your user programmable frequency 'bin'. It's not hard, but if you've never done frequency programming before, it can be a mystery. You might want to call in a marine electronics tech familiar with marine SSB equipment. Try Don Melcher of HF Radio On Board (Alameda) at (510) 814-8888; Shea Weston of Offshore Outfitters (San Diego) at (619) 225-5690; Steve Helms of Marine Radio Consultants (San Diego) at (619) 276-5530; Ron Romaine of KKMI (Richmond) at ron@kkmi.com. Or me. I'll try to talk you through the process.

I've got two final tips.

First, if you sent your Icom 802 to the factory to get the 'clipping' problem fixed, you'll note that there are two places to plug in the antenna. One is for the DSC antenna, the other for your SSB antenna. Unfortunately, they are not clearly labeled. A number of people have gotten their radios back and plugged their SSB antenna into the wrong port. As a result, transmit and receive range are minimal. You would see an antenna tuner error if plugged into the wrong jack. Set it up temporarily and test it with time signals.

Second, Icom is very conservative in an attempt to make sure none of their radios violate FCC rules on output power and how wide the signals are. I think they are too conservative. If you get that voice compression software unlocked, your radio transmissions will boom out with a commanding signal like Voice of America. The software upload is only available from authorized Icom dealers. They can come aboard and plug it into your radio, as well as the most recent 'user channel' update. It usually takes just 15 minutes.

— *gordon west*

SCHOONMAKER POINT MARINA

• IN SAUSALITO •



Call the Marina Office
for more information

415•331•5550

FAX 415•331•8523

or check our web site at
www.schoonmakermarina.com

85 LIBERTY SHIP WAY, #205
SAUSALITO, CA 94965



160 Berth Marina in one of the most beautiful spots on the Bay

- Visitor berths • Guest moorage able to handle yachts up to 200 ft.
- Dry storage • Waterfront Offices • Three-ton Hoist • Windsurfing
- Deli • Beach • Rowing • Kayaking • Yacht clubs always welcome

BAJA HA-HA XIV

BROUGHT TO YOU BY THESE OFFICIAL SPONSORS

Grand Opening
2007



MARINA RIVIERA NAYARIT
AT LA CRUZ

• Now accepting reservations • 150-Ton Travel Lift
Call 011-52-322-779-9191 or 011-52-322-293-4064
www.marinalacruz.net or info@marinalacruz.net



CORTEZ CHARTS

NAVIGATION CHARTS - CRUISING GUIDES
TIDE TABLES - LIGHT LISTS
GPS POINTS

www.gerrycruise.com

Summer
is safe at
Paradise..



Enjoy
your stay
with us!

011-52-322-22-66728 • www.paradisevillage.com
marina@paradisevillagegroup.com

Making Fresh Water, Worldwide.™



Most energy efficient • Push button operation
Quick & easy installation • Low maintenance

(415) 526-2780

www.spectrawatermakers.com

RIGGING ONLY

Standing and running rigging, lifelines, furlers,
winches, main slider systems, windlasses,
travelers, wire terminals, blocks and more...
Expert advice for selection and installation

Our 22nd Year

www.riggingonly.com



Let Marina El Cid
Welcome You to Mexico

A Cruiser's Paradise!

www.elcid.com

qcevallos@elcid.com.mx

011-52 (669) 916-3468

HYDROVANE

SINCE 1968

Survive Your Dream

ECH,O Tec Watermakers

604-925-2660

www.hydrovane.com



The Rally Committee encourages you to patronize

HUGE FLEET POISED FOR OCT 29 START

As you read this, the second largest Baja Ha-Ha fleet ever is making final preparations for the October 29 start. Nearly 180 boats have entered from all over the West Coast.

The Baja Ha-Ha, of course, is a 750-mile cruisers' rally from San Diego to Cabo San Lucas, with stops along the way at Turtle Bay and Bahia Santa Maria.

While enroute, the rally committee hopes to send occasional updates to 'Electronic Latitude, hopefully with photos. Look for these reports at www.latitude38.com.

As if often stated, entrants should be clear that this offshore sailing event definitely is not a hand-holding service for those incapable of making this trip on their own. However, it is an ideal opportunity to get acquainted with hundreds of like-minded cruisers as the fleet 'cruises-in-company' along the Baja coast. The two stops on the way to Cabo San Lucas give even the slowest boats a chance to catch up, and allow everyone to rest and recreate.

Look for a final installment of Baja Ha-Ha profiles in the November edition of Latitude 38, and a complete event recap in December.

VISIT

WWW.BAJA-HAHA.COM



and other windvanes



Emergency
Rudder



Factory
Direct

432 South 1st Street • Pt. Richmond, CA 94804
Tel: (510) 215-2010 • Fax: (510) 215-5005
email: scanmar@selfsteer.com • www.selfsteer.com

Boat Electronics. Done right ... priced right.

CAL MARINE ELECTRONICS

Sales - Installation - Service - Integration

415-391-7550

www.calmarineelectronics.com



Not just a marina - a cruiser's community
Your best destination across the Sea...

www.marina-mazatlan.com

011-52 (669) 916-7799

elizarraga@marinamazatlan.com

Satellite Phone

Rentals • Sales • Accessories



High Speed Satellite Internet Access

888-884-7623

www.allroadsat.com

San Diego, CA

OPEQUIMAR

MARINE CENTER CENTRO MARINO

A Full Service Boat Yard in Puerto Vallarta
88 ton Travellift • Parts • Service • Repairs

011-52 (322) 221-1800

www.opequimar.com

info@opequimar.com

Almar Marinas

The West's Finest

The West's finest marinas, with locations at
Alameda, Treasure Island, Oakland, Ventura,
Oxnard, San Diego and Hawaii.

800-307-ISLE (nationwide) • www.almar.com



the advertisers who make this event possible.

Ventura Harbor Boatyard

Full & Self Service Facility • Up to 165 Tons
On-Site Chandlery

(805) 654-1433 • www.vhby.com
1415 Spinnaker Drive, Ventura, CA

The perfect solution for long
line storage on your vessel!

Marine Products from the World to the USA



QuicklineUSA

15561 Computer Ln, #A, Huntington Beach, CA 92649
714-843-6964 714-843-6906 fax
www.quickline.us or info@quickline.us

TOTAL YACHT WORKS

Your Authorized Yanmar Dealer is now in the new harbor boat yard facility next to Marina Mazatlan. E-mail: TotalYachtWorks@hotmail.com See: www.TotalYachtWorks.com Phone: 011-521-669-117-0911 Call: VHF channel 22



"We Fix What Won't Work"



FULL SERVICE MARINA

New breakwater • New docks

New U.S. #: (619) 618-0615

Tel: 011-52 (612) 122-1646

email: marinalapaz@prodigy.net.mx

www.marinadelapaz.com

KATADYN®

MAKING WATER DRINKING WATER

Watermakers that improve
the cruising lifestyle.

(800) 755-6701

marine@katadyn.com



MARINER'S GENERAL INSURANCE GROUP

Cruise with
Confidence

(800) 992-4443

www.marinersinsurance.com

See Our Half-Page Ad In This Issue

Newport Beach, CA • Burlingame, CA • San Diego, CA • Seattle, WA • Bradenton, FL

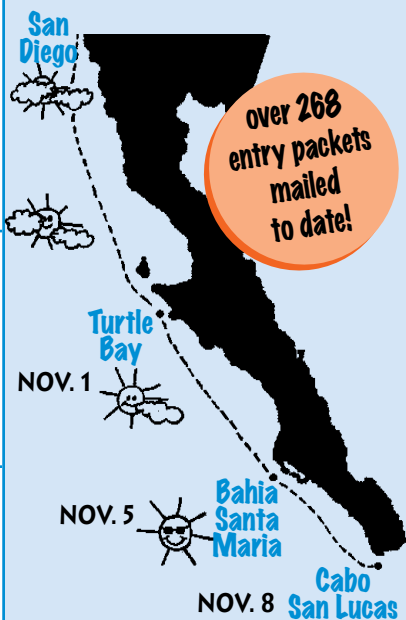

IMPORTANT DATES

Oct 3 — Mexico Only Crew List and Baja Ha-Ha Party, Encinal YC; 6-9 p.m.

Oct 28 — Skipper's meeting, 11 a.m., at Cabrillo Isle Marina, San Diego.

Oct 28 — Ha-Ha Halloween Costume Party and BBQ, 1 p.m. at Cabrillo Isle; co-hosted by West Marine.

Oct 29 — Start of Leg 1

Nov 10 — Awards presentations hosted by the Cabo Marina.

Baja Ha-Ha Inc.

401-F Miller Ave., PMB 140
Mill Valley, CA 94941

www.baja-haha.com

There is no phone number for the Baja Ha-Ha. And please don't phone Latitude 38 with questions, as the Ha-Ha is a completely separate operation.



Mexico Cruising Insurance Blue Water Insurance

(800) 655-9224 • (619) 226-6702

Fax: (619) 226-8513

Mexico full or part-time • Crew of two

www.bluewaterins.com



Located in La Paz, we are the newest, best and most secure marina in all of Mexico.

Contact us at: CostaBajainfo@BellPortGroup.com

Tel. from U.S.: 011 52 612 121 6225

www.costabajaresort.com



THE CRUISER'S CHANDLERY

www.downwindmarine.com
info@downwindmarine.com

(619) 224-2733 • Fax (619) 224-7683

The southbound
cruiser's source for
EVERYTHING!

Can't Wait to Outfit?

Use our website to
order early!



619-226-2622

CALL US about Watermakers, Generators, Combos or Diesel Re-power, we will design and install a system to meet your needs in time for the BAJA HA HA.

sales@watermakerstore.com • www.watermakerstore.com



Professional yacht brokers
located in the heart of
San Diego's boating community.
Specialists in cruising
sailboats for 26 years

info@yachtfinders.biz • www.yachtfinders.biz

866-341-6189 • 619-224-2349

Fax (619) 224-4692

www.MexicoBoating.com

- ✓ Baja Bash II Capt. Jim Eilers
- ✓ The Baja & Sea of Cortez Anchorage Map (fold out) Hemingway-Douglass
- ✓ Mexico Boating Guide Capt. Pat Rains
- ✓ Cruising Ports: the Central American Route

West Marine

We make boating more fun!

Call 1-800-BOATING

(1-800-262-8464)

for a catalog or the store nearest you.

BAJA HA-HA PROFILES, PT II

In a way it's a shame we've gone to all the trouble to give these Baja Ha-Ha rally entrants their 15 minutes of fame here — because a lot of them won't have a single moment in the coming weeks to even thumb through the magazine. They'll be too darned busy chasing their tails around their boats, frantically attempting to complete their ever-enlarging 'to do' lists prior to what, for most, will be the biggest cruise of their lifetimes.

Every year Rally Committee members are told that the event's concrete starting date, October 29 this year, is one of the greatest benefits of signing up for the event. "It's the only thing," they explain, "that finally put an end to our years of procrastinating!"

As you'll read in these mini-bios, this year's fleet is comprised of a wide variety of boats, crewed by folks who've earned their cruising money doing everything from solar engineering to defense contracting. We wish them all fine sailing and boatloads of fun!

(Bios are presented in the order that the boat signed up. Look for a final installment in November and a complete event recap in December.)

Tropical Dance — Gulfstar 50 Daniel & Reylyn Yarussi San Clemente

Occupations: Daniel, director of photography (ret); Reylyn, self employed

Add'l Crew: Ken & Janet Silver, Barbara Merriman

Quote: "It's time to dance again!"

Cruise Plans: Mexico, Central America, Caribbean. . .

Noteworthy: Since 2001 Daniel has logged 17,000 sea miles.

Itchen — Hunter 37

TJ & Julie Edwards, Tacoma

Occupations: TJ, RN; Julie, RT (both ret)

Quote: "No great adventure has been experienced from the comfort of a cushioned chair within the confines of a house.

Cruise Plans: Continue to point south, east. . . or west

Noteworthy: TJ & Julie met in a small Eskimo village; between them, they have three kids serving in Iraq.

ProMotion — Santa Cruz 40 West Marine Employees, Santa Cruz

Occupation: Captain Holly Scott and her five-person crew are all West Marine employees

Add'l Crew: TBD

Quote: "I started sailing when I was three!"

Cruise Plans: Post rally, the boat will return home quickly with possible stops in the Channel Islands

Noteworthy: Purchased new in '83 by West Marine founder Randy Repass, *ProMotion* has been used for employee sail training for more than 20 years. Having logged 200,000 miles, including nine West Marine Pacific Cups, she is most likely the 'most experienced' boat in the fleet.

Beach Access — Lagoon 380 cat Glenn & Monica Twitchell Long Beach

Occupations: Glenn, electrical contractor; Monica, dental tech. advisor

Quote: "As our cat's name implies, she will give us access to most of the world's beaches."

Cruise Plans: Mexico and beyond for as long as the money lasts

Noteworthy: They made their cruising plan 15 years ago. But today their boat is twice as big and cost five times the



Monica and Glenn plan to survey the sandy parts of the world aboard 'Beach Access'.

original estimate. They say they're two years behind schedule, "But we're going anyway!"

Syren — J/160

Joseph Christian & Larry Beggs, Newport, OR

Occupations: Joesph, businessman; Larry, architect

Add'l Crew: Dave Hickman & Mike Fitzhugh

Quote: "We joined the rally because we are silly enough to gladly risk injury and

death in the pursuit of adventure (and fun)."

Cruise Plans: TBD

Noteworthy: The partners purchased this 2003 J/boat just one year ago.

Serenity — Catalina 42 Mk II David Albert, Oceanside

Occupation: real estate broker

Add'l Crew: Karie Horst, Hugh & Nicki Talman

Quote: "This is the best way I can think of to escape my workoholic behavior."

Cruise Plans: must return home in December

Noteworthy: Impressive crew: Karie is a licensed skipper with thousands of bluewater miles; Hugh is the great-grandson of yacht designer Hugh Angleman.

Mañana — Seawind 1000 cat Tom McCarthy & Andrea Reich, Aptos

Occupations: Tom, accountant/restauranteur; Andrea, CPA

Add'l Crew: Steve Shugart & Conni Butler

Quote: "The boat's name says it all. We're planning on a slow sail/drift south."

Cruise Plans: commuter cruise from P.V., then eventually on to the Carib

Noteworthy: Tom and Andrea have cruised previously in the Canadian Maritimes and the Eastern Caribbean.

Footloose — Gulfstar 43 Diane Brown & Ward Latimer Emery Cove

Occupation: Diane, facilities manager; Ward, sailing instructor

Add'l Crew: Bruce & Diana Powell, Eric Foster, Laura Migdal

Quote: "Lighten up, go to Mexico."

Cruise Plans: leave boat in La Paz or Loreto

Noteworthy: Ward started sailing at age six.

Maya — Lafitte 44

Rick Meyerhoff, Sausalito

Occupation: naturalist

Add'l Crew: Tim Ryan & Steve Grocer

Quote: "Live each day as its own special gift."

Cruise Plans: Z-town for Christmas, Gold Coast & Sea of Cortez

Noteworthy: Rick's 38-year sailing career includes a trip from Florida to San Diego.

— HASTA LA VISTA, BABY

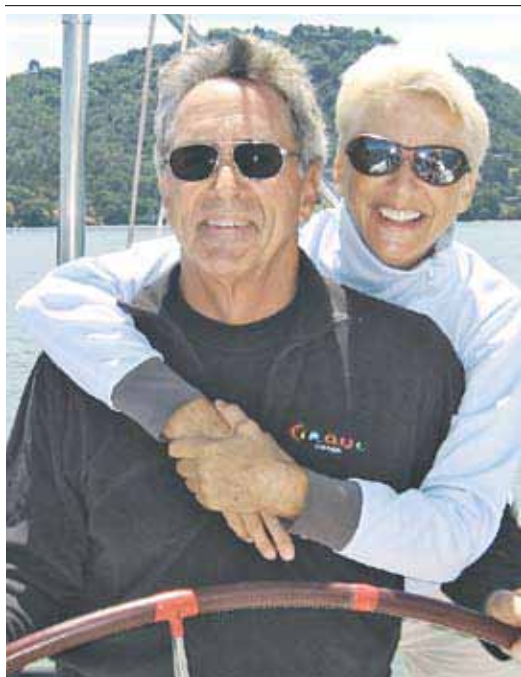

If Louis and Laura of 'Cirque' are looking for babysitters, they've entered the wrong event.

Cirque — Beneteau 42s7
Louis Kruk & Laura Willerton
San Francisco

Occupations: Louis, phys. ed. teacher; Laura, United Air acct. exec. (both ret)
Add'l Crew: TBA

Quote: "We heard that the Baja Ha-Ha is a wonderful offshore babysitting service."

Cruise Plans: La Paz, Mazatlan, P.V., then 'bash' home.

Noteworthy: When Louis used to juggle for his students, they asked if he ever worked in the circus. Now he's "the ringmaster of the *Cirque*" (meaning circus).

Carpe Diem — Fantasia 35
David Moore, Alameda

Occupation: electronics engineer
Add'l Crew: Brett Wylie, Chuck Edelman, Ken Milnes

Quote: "I'll take a left outside the Golden Gate, then sail until it stops being fun."

Cruise Plans: none. . .

Noteworthy: Since learning to sail in the '70s, David has been dreaming of cruising.

Tin Soldier — Waterline 50
The Middleton family
Vancouver, BC

Occupations: Glen, principal (ret); Marilyn, teacher

Add'l Crew: son Jaryd, Glen's brothers Don and Rob

Quote: "The going may get tough,

but the right people can have fun in a ditch."

Cruise Plans: the South Pacific and beyond

Noteworthy: It's a safe bet that this is the only boat in the fleet bringing along a pet gerbil, 'Bear'.

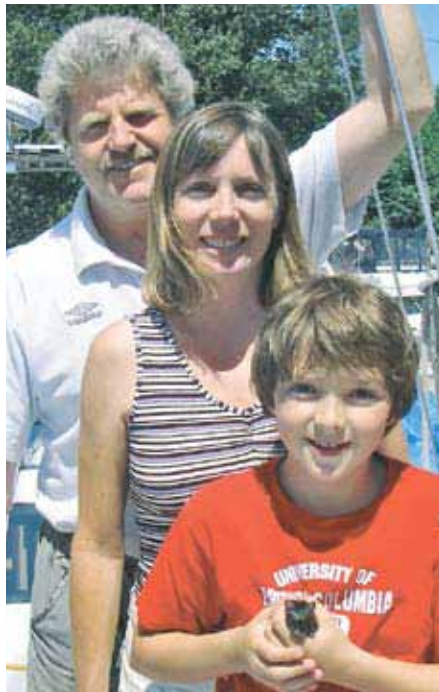

School's out aboard 'Tin Soldier' from Glen, Marilyn and Jaryd.

Aurora — Valiant 42
Jim & Sheilagh Goetsch
San Francisco

Occupation: Jim, project manager; Sheilagh, mental health therapist

Add'l Crew: Dan Rogers & Mitch Boothe

Quote: "We've held a dream of cruising for the entire 35 years we've been married."

Cruise Plans: Mexico, then west

Noteworthy: Jim was a Navy pilot in Vietnam before becoming a software engineer.

Wind Trekker — Corsair 31 tri
Tom Brown, Oxnard

Occupation: software engineer (ret)

Add'l Crew: Lan Yarbrough

Cruise Plans: coastal cruising from P.V. base

Noteworthy: Tom plans to track other 'Ha-Ha geeks' via their VHF DSC position report input. Lan is an ASA sailing instructor.

Fidelitas — Tayana 460
Gernot Winkler, Chula Vista
Occupation: dentist
Add'l Crew: Greg Boyer
Quote: "Looking forward to lots of fun."
Cruise Plans: bash home to San Diego soon after rally
Noteworthy: Gernot bought this boat brand new in 2001.

Second Wind — Beneteau 331
The Reinking family, San Diego
Occupation: Cory, network engineer; Melissa, sales ops manager
Add'l Crew: Cory's father Steve
Quote: "We're off on a new life adventure."
Cruise Plans: commuter cruising out of La Paz
Noteworthy: Although Cory is a grown man, his dad will still be giving him guidance — via his role as navigator.

Haufruen — Thackwray 94
PK Connor & Julia Norlin
Campbell River, BC
Occupation: PK, businessman; Julia, RN (both ret)
Quote: "We never party, do group cruises or race. Perhaps it's time to change."
Cruise Plans: on to Central America
Noteworthy: Having no mainsail, PK explains that his 90-ton ketch only goes downwind.

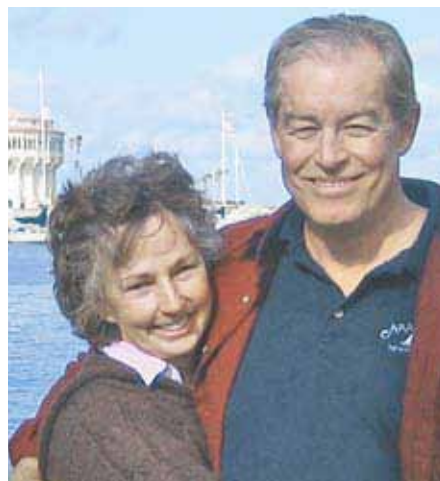

Sheilagh and Jim have been waiting to cruise on 'Aurora' for a l-o-n-g, l-o-n-g, time.

Simple Pleasures — Freedom 36
Bernard Slabeck, San Francisco
Occupation: photographer (ret)
Add'l Crew: Ben Hackett, Dough Storkovich, Otto Weilert
Quote: "I've gotta live life now — I may not get another chance."

BAJA HA-HA PROFILES, PT II

Cruise Plans: "The plan: to have no plan."

Noteworthy: Bernard spent several years crewing on other people's boats — including the Rally Committee cat *Profligate* — before buying this boat two years ago.

Full Quiver — Beneteau 405 First Steve & Pam Lannen, San Francisco

Occupation: Steve, restaurant owner; Pam, Spanish teacher (both ret)

Add'l Crew: Steve's brother Mike, his wife Judy Hagar, plus Roger Cisl & Steve Yong

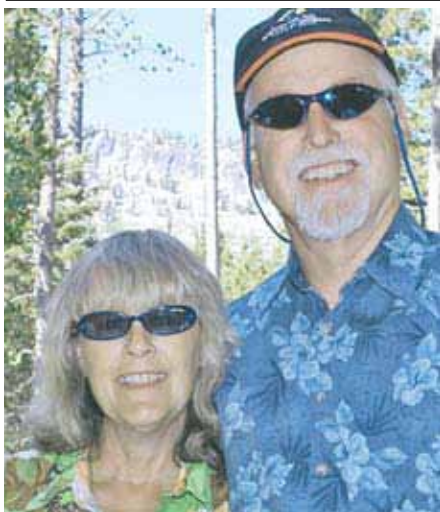

Pam and Steve of 'Full Quiver' started out racing and gradually worked their way into cruising.

Quote: "We raced together in '68 at Cal State Northridge, and are still sailing together today." (Nearly 40 years later.)

Cruise Plans: Mexican waters until hurricane season

Noteworthy: This entire crew has been sailing together for 30 years. Between them, they have translators for Spanish, German, French, Italian, Swiss German and Chinese.

Ciao — Catalina 34 Juan & Eva Spampinato Pt Richmond

Occupation: auto tech. (ret)

Add'l Crew: Art Stascausky & Dick Taylor

Quote: "Heck! I'm 65. If not now, when?"

Cruise Plans: it's anybody's guess

Noteworthy: Juan says the most interesting thing about his boat is that it's his, it's paid for and it floats!

Rhapsody — Beneteau 510 Patrick & Patricia Horton, San Diego

Occupation: Patrick, software engineer/musician

Add'l Crew: TBD



Patricia and Patrick of 'Rhapsody' are obviously well-rounded watersports types.

Quote: "Excitement filled with trepidation. . . we expect to be changed by the experience."

Cruise Plans: south to the Canal, then to Galveston, TX

Noteworthy: The couple only began sailing a few years ago, but fell in love with the sport and bought this "French princess" only six months ago.

Entropy — Hunter 456 Robert & Carol Forbes Newport Beach

Occupation: Robert, company founder (ret); Carol, producer

Add'l Crew: TBA

Quote: "Whatever you do, or dream you can, begin it. Boldness has genius, power and magic in it." (Goethe)



We suggest you follow Robert and Carol of 'Entropy', as they're both long-time navigators.

Cruise Plans: Christmas in P.V., spring in Marquesas, then. . . ?

Noteworthy: Both Robert and Carol are seaplane pilots and Robert holds a USCG Master's license.

Mischief II — Island Packet 380 Bob & Donna Miller, San Francisco

Occupation: Bob, electrician; Donna,

postal worker (both ret)

Quote: Of his early El Toro days, Bob remembers, "We also did some sailing, but mostly I remember a lot of swimming and righting the boat."

Cruise Plans: Sea of Cortez, south, then back home

Noteworthy: Bob claims he got interested in sailing while he was a teenager by reading adventure books about traveling to the less-explored parts of the world.

Wand'rin Star — Hans Christian 44 Gary & Dorothy Engelman St. Clair Shores, MI

Occupation: Gary, designer; Dorothy, teacher (both ret)

Add'l Crew: William & Masuko Giesecke

Quote: "Life is a great big canvas. Throw all the paint on it you can." — Danny Kaye

Cruise Plans: Galapagos, Panama, Montana. . . who knows?

Noteworthy: This is one of only 15 Hans Christian 44 pilothouses built, and the first to do the Ha-Ha.

Pangea — J/30

Mike & Hunter Leary, Ventura

Occupation: Mike, geologist; Hunter, 15, student

Add'l Crew: Karl Deardorf

Quote: "Keep it simple, silly."

Cruise Plans: explore Sea of Cortez, then to San Carlos and trailer home

Noteworthy: Father and son will be joined by wife and daughter for the cruise through the Sea.

Pipe Dream — CF 37

John Davis & Nancy Callahan Long Beach

Occupation: John, business owner

Add'l Crew: Tony Chapman & Kelly Beaver

Quote: "To race or not to race? Would anyone notice?"

Cruise Plans: return to SoCal

Noteworthy: John did both the '03 and '05 TransPacs on this, his first, boat. He and Nancy just began sailing in 1998.

Talaria — Ericson 38

Bill Martin, Sausalito

Occupation: Bill, marine biologist (ret); Jean, hydrogeologist

Add'l Crew: son Bert Martin, brother-in-law Jerry Weare & Mike Josselyn.

Quote: "The patient sailor will have fair weather."

Cruise Plans: south to Ecuador, then to French Polynesia

Noteworthy: They've lived aboard

— HASTA LA VISTA, BABY



With any luck the Rowe family will have a jolly time aboard 'Merry Rowe's'.

for 12 years, 9 of which were aboard a Ranger 33.

**Zephyra — Morgan OI 41
Russ & Debbie Noorda
Lake Tahoe**

Occupation: Russ, charter captain, rigger, sailmaker; Debbie, medical office manager

Add'l Crew: Mark Glines, Joe Oder, Mike Grimm & Charles Quaglieri

Quote: "Kids are grown, house is paid for, and the honeymoon is back on."

Cruise Plans: a season or two in Mexico, then south to Ecuador and on to the South Pacific in 2009

Noteworthy: No wonder Russ makes his living in the boat biz. He started sailing at age 5.

**Merry Rowe's — Hallberg Rassy 46
The Rowe Family, San Diego**

Occupation: David, director of operations; Tania, 'domestic CEO'

Add'l Crew: sons Bryan, 10, and Kevan, 7

Quote: "We're taking a year of retirement early, so we can enjoy it with our children."

Cruise Plans: cruise Mexico until spring

Noteworthy: The cruising dream apparently struck them only recently. Dave began sailing in '03 and Tania in '05.

Dolfino — Catalina 42Rick Lino, Marina del Rey

Occupation: defense contractor (ret)

Add'l Crew: Art Urbin & Patricia Flood

Quote: "We all need some adventure to know we're still alive."

Cruise Plans: to P.V. then home

Noteworthy: Art has owned this boat since she was new in '99. He did the '04 Ha-Ha with the same crew.

**Tribute — Farr 58
Neil Kaminer & Fran Finlay
Mermaid, DE**

Occupation: Neil, solar engineer; Fran, nurse

Add'l Crew: Stefan Berlin-ski

Quote: "We're ready for warm friends, warm water, warm memories and cold drinks."

Cruise Plans: eventually through the Canal and on to the Eastern Seaboard

Noteworthy: They were married on the Caribbean island of St. Vincent, sailing through the Grenadines on their honeymoon aboard a chartered Beneteau 47.



Fran and Neil are heading back to the tropics, where their marriage began, on 'Tribute'.

**Blue Lightning — New York 36
Michael Riley, Seattle**

Occupation: Construction manager

Add'l Crew: Bryan Laubscher, Emily Angell, Derek Jacoby

Quote: "I'm in this to stretch my cultural boundaries — and to actually see the sun in December."

Cruise Plans: winter in Mexico and

Central America, then. . . ?

Noteworthy: Although he never even saw a sailboat until he was 18, Michael claims that he wanted to own a sailboat since age six. Curious, as his entire family came from Nebraska. "Perhaps it's because 'prairie schooners' were big there."

**Del Norte — Rawson 30
Sam Kesten, Sausalito**

Occupation: special ed. instructor

Add'l Crew: John Pressley

Quote: "The possibilities are endless and they all include surfing!"

Cruise Plans: surfing

Noteworthy: Sam's one of the younger skippers in the fleet at just 24. If you want to get on his good side, call him a "good kid." He loves it!

**Little Wing — Sabre 362
Chris & Nancy O'Brien, San Diego**

Occupation: Chris, neurologist; Nancy, ballet dancer

Quote: "There is no time like now to do what needs doing. . ."

Cruise Plans: Post rally, return to the grind

Noteworthy: Chris has been sailing since age 10.

**Ticket — Beneteau 47.3
Rick Niello, Sacramento**

Occupation: automobile dealer

Add'l Crew: Pat Burns, Steve Shower, David Townsend, Toby Mumford & son Derrick Niello

Quote: "My passion and escape."

Cruise Plans: a long cruise with a great group of sailors. . .

Noteworthy: Rick's 23-year-old son Derrick, has already sailed from S.F. all the way to Australia.

**Lady Jane — Catalina 36 MKII
Ray & Jane Oleson, Nevada City**

Occupation: Ray, attorney

Add'l Crew: Nate Oleson, Lorinda Harris

Quote: "The Lady Jane will have the spirits of Mick Jagger and Keith Richards aboard."

Cruise Plans: commuter cruise for the winter and home in the spring.

Noteworthy: Keeping it all in the family — sailing with wife, son and niece.

**Air Ops — Amel Maramu 13.8M
Dave & Merry Wallace
Rancho Murietta**

Occupation: Dave, Navy pilot & engineer; Merry, graphic artist (both ret)

Add'l Crew: Ron Feldman, Anita Giani, Vern & Cheryl Lawson

Quote: "Each couple has done the Ha-

BAJA HA-HA PROFILES, PT II

Ha before on their own boats so we have no excuses!"

Cruise Plans: Cruise the Sea of Cortez and the mainland until "we can't stand it anymore!"

Noteworthy: This will be Dave & Merry's third Ha-Ha.

Snow Goose — Cooper Maple Leaf 50 Michael McIntyre, Marina Del Rey

Occupation: airline pilot (ret)

Add'l Crew: Peter Owen, Carolyn Flaherty

Quote: "It's almost 'finished.'" (The boat, that is.)

Cruise Plans: heading to the South Pacific

Noteworthy: Michael thinks he should get a positive handicap because he's "learning to be retired."

Mocakyki — Lafitte 44 Frank Hagar & Joni Fisher San Clemente

Occupation: Frank & Joni are both hydrogeologists

Add'l Crew: Kiara Fisher-Hagar, Maurice Fisher & Bill Bialkowski

Quote: "To have an adventure, you



Next year Tobé and Roger of 'Palapa' hope to pop the cork to begin a world cruise.

have to be a little bit cold, a little bit hungry and a little bit scared."

Cruise Plans: planning ahead, after the 2009 Ha-Ha, they'll head south

Noteworthy: Under previous owners, the boat completed a 20-year circumnavigation (1986 - 2006).

Jim N' I — Freedom 32

James & Doris Maxwell, Rio Rancho

Occupation: James, N/A; Doris, realtor (both ret)

Add'l Crew: Earl & Marsha May

Quote: "We're filled with excitement and eager anticipation."

Cruise Plans: Sea of Cortez

Noteworthy: Jim started sailing in 1940, Doris 66 years later, in 2006.

Third Day — Pearson 365

**Richard & Lori Boren
Bakersfield**

Occupation: Richard, inventor & dreamer; Lori, physician's assistant

Add'l Crew: Richard Booth, Sean McIntyre & Thomas Benner

Quote: "God created the oceans on the 'Third Day' and gave inspiration for the Baja Ha-Ha sometime shortly thereafter!"

Cruise Plans: to prepare for their upcoming four-year cruise

Noteworthy: The Borens are leaving their 8 and 9-year-old kids with the grandparents during the Ha-Ha.



Blue Sky
ENERGY

Increase Your Solar Output With Solar Boost™ MPPT Solar Charge Regulators

Get All The Power You Need To Weather Any Storm

The Solar Boost™ 3024i & 2000E are two of the most reliable Solar Charge Controllers on the market & our patented technology extracts all the power your solar panels can deliver, up to 30% more !

Blue Sky Energy Inc. gets rave reviews in Practical Sailor. Read the article at www.blueskyenergyinc.com

800-493-7877 or 760-597-1642
2598 Fortune Way, Suite K, Vista, CA 92081 USA
E-mail: sales@blueskyenergyinc.com
Web: blueskyenergyinc.com

QUALITY....RELIABILITY....BLUE SKY ENERGY, CHANGING THE WAY SOLAR IS USED EVERYDAY





— HASTA LA VISTA, BABY

Lorien — Islander 30

Guy & Susie Carlson, Belmont

Occupation: Guy, truck driver; Susie, HR benefit specialist (both ret)

Cruise Plans: to make this "a long-term project"

Noteworthy: The Carlsons are bringing along a dive hookah.

La Palapa — Catalina Morgan 440 Roger & Tobé Hayward Long Beach

Occupation: Roger, engineer (ret); Tobé, aerospace engineer

Quote: "I'd rather be lucky than good."

Cruise Plans: La Paz, maybe Costa Rica, prep for 2008 'round-the-world

Noteworthy: They will have owned the boat exactly one year at the start of the race.

Sooner Magic — Beneteau 47.7 Garland Bell, San Rafael

Occupation: Real estate broker

Add'l Crew: Jim Taylor

Quote: "I've always been a racing sailor, where if you're not the shark,



It seems reasonable to us for Bill and Lisa to bring their pup aboard 'Beyond Reason'.

you're the bait. Looking forward to the only bait being the tuna caught on the way down."

Cruise Plans: a couple of months in P.V., then back to San Diego.

Noteworthy: This boat has two flat screen TV's.

Beverlee — Pacific Seacraft 32 Brad White, San Gregorio

Occupation: Construction Supervisor

Add'l Crew: Ryan White, Noel Chamberlain

Quote: "It's an adventure, maybe it'll help me grow up to be a bum."

Cruise Plans: to inspire a life change

Noteworthy: Previous to this cruise, Brad had never taken his boat out of the Bay.

Contigo — Islander 36 Bill Cryslar, Victoria BC

Occupation: hospital administrator

Add'l Crew: Rik Refrem, Wayne Hanson & David Paul

Quote: "What time is it please? What day is it today? What month is this please?"

Cruise Plans: Southern Mexico, then back to Victoria by way of Hawaii

Noteworthy: Bill will singlehand to San Diego where he'll rendezvous with his rally crew.

Beyond Reason — Hans Christian 43 Bill & Lisa Novak, Winters

Occupation: Bill, forklift driver; Lisa, receptionist (both ret)

Quote: "Life is too short not to have

OPEQUIMAR

MARINE CENTER CENTRO MARINO

88-ton (max)
Travelift!
Length to 100'
Width to 23'

Puerto Vallarta, Jalisco, Mexico
Paseo de la Marina Sur #214 • Marina Vallarta, 48354
Tel: 011 52 (322) 221 1800 Fax: 011 52 (322) 221 1978
email: info@opequimar.com

Visit Our
Yacht Club!

Opequimar Yacht Club

First Class • Full Service
On site dining, Internet, socials

BOAT SALES
NEW & USED BROKERAGE
www.opequimar.com

West Marine

We make boating more fun!

SIMRAD

A KONGSBERG Company

PETTIT

marine paint

Come to Mexico,
Enjoy the Mexican Riviera,
Repair your boat at
OPEQUIMAR

BAJA HA-HA PROFILES, PT II

fun; quit your whining!"

Cruise Plans: Baja, El Salvador, Guatemala. . .

Noteworthy: They'll be on the lookout for some good cigars.

Avalon — Mason 43
Jim & Pamela Jennett
South Lake Tahoe

Occupation: Jim, Realtor; Pamela, writer/editor

Add'l Crew: Steve Davis

Quote: "Life is short, let's go cruising!"

Cruise Plans: Puerto Vallarta and onwards

Noteworthy: The boat has done more bluewater cruising than its owners.

Tamara Lee Ann — Celestial 48
Doug & Tamara Thorne
San Francisco

Occupation: Doug, financial planner; Tamara, regional director

Add'l Crew: Richard & Robin Schaper, Roger Mammon

Quote: "Looking forward to Ha-Ha #2"



Putting their jobs far behind them will be, well, 'Perfect' for this crew.

Cruise Plans: have a delivery crew do the Bash to Newport Beach.

Noteworthy: There are only about 50 Celestial 48s worldwide.

Perfect — Beneteau 461
Rob & Carol Woltring, Oakland

Occupation: Rob, automobiles; Carol, public health professional

Add'l Crew: Hal & Laurie Lynam

Quote: "Looking forward to meeting new friends, the peace of being at sea and putting jobs far behind."

Cruise Plans: La Paz, the Sea, then back home in early spring

Noteworthy: The couple has owned more than 20 boats.

Scott Free — Hylas 42
Bill & Susan Hall
West Vancouver, BC

Occupation: Bill, management consultant; Susan, RN

Add'l Crew: Glenn Greenfield & Pat Hamburton

Quote: "It's time to start cruising instead of racing boats and racing through life."

Cruise Plans: Sea of Cortez

Noteworthy: Bill is a seasoned blue-water sailor, having done the Newport to Bermuda race and others.

Sans Clés — Royal Passport 43
Lyman & Terri Potts, Portland OR

Occupation: Lyman, CFO (ret)

Add'l Crew: Joel & Mary Thornton

service &
 quality
 at the best
 price

75 ton travel lift
 Paint, carpentry & blister repair
 S.S. & aluminum mig & tig welding
 Mechanical & structural work
 Full service marina
 Short & long term rentals

bajanaival.com

Ensenada, México
 Ph 011-52-646-174-0020
 Fx 011-52-646-174-0028



**Boatyard
 & Marina**

VALLARTA'S
 marine center

VISIT OUR NEW LOCATION
 at MARINA VALLARTA

- Engines
- Accessories
- Boats
- Lures
- Fishing Equipment
- Parts
- Luvs
- Watersports Equipment



www.zaragoza.com.mx • info@zaragoza.com.mx
 TEL/PH: (322) 22 21436 • (322) 22 63232
 FAX: (322) 22 23736



— HASTA LA VISTA, BABY

Quote: "They say no man is an island, but I've met plenty of *atolls!*"

Cruise Plans: Mexico, Central America & the Caribbean

Noteworthy: The recipe for Terri's son's famous Irish Cherry Bomb cocktail will be provided upon request.

Somerset — Catalina 38

Ronald Burkard, Costa Mesa

Occupation: financial planner

Add'l Crew: Anei Froehlich

Quote: "If my buddies can cross the South Pacific in a CF 37, I can coastal cruise to Panama."

Cruise Plans: La Paz, Sea of Cortez and points south

Noteworthy: In years past, Ronald sailed from Costa Rica to the Galapagos.

Sagittaire — Brewer Pilothouse 47

**Michael & Diane Quiriconi
Kirkland WA**

Occupation: Mike, mechanical engineer; Diane, homemaker

Add'l Crew: Susan Murphy, David



Michael and Diane of 'Sagittaire' are ready for a change of pace.

Niedziejko, Lucas Adamski & Kimberlee Osmun

Quote: "We are ready to move out of suburbia and onto the blue ocean — living aboard without killing each other."

Cruise Plans: Mexico, back to Seattle via Hawai'i, then to the South Seas and beyond

Noteworthy: They are relatively new to cruising, so they're hoping to meet lots

of fellow sailors and gain experience.

Wingstar — Fraser 51

Chris & Victoria Nugier, Sonora

Occupation: Chris, high school teacher; Victoria, elementary school teacher

Add'l Crew: Sierra (15), Katie (13) & Christina (8) Nugier, Marty & Cole (6) Mellera, Buddy the sailor dog

Quote: "Plan like you'll live forever. Live like you'll die tomorrow."

Cruise Plans: sail home soon after the rally

Noteworthy: The Nugier family nearly went cruising 10 years ago but put their plans on hold when their oldest was diagnosed with a brain tumor.

Hiatus — CT 47

Kent & Heather Sisk, Portland OR

Occupation: Kent, real estate; Heather, management

Add'l Crew: Dane & Stephanie Winchester, John Weil, Ray McCormack

Quote: "Bring it on!"

Cruise Plans: continue cruising south

IF THERE'S ANYTHING YOU WANT TO GO OVERBOARD ON, IT'S SAFETY.

To purchase Bluestorm products from one of our dealers, visit www.bluestorm.us

 **BLUESTORM**
THE CHALLENGE OF WATER

Plympton, MA, USA, Toll free 877.688.5657
www.bluestorm.us

BAJA HA-HA PROFILES, PT II

Noteworthy: The couple has only owned this boat, their 8th, for 7 months, and are quite proud of it.

Delight — Hunter 36

Albert Miller, Carmichael

Occupation: electrical engineer (ret)

Add'l Crew: Jerry Ward

Quote: "After 27 years of talking about going cruising to Mexico, we are finally going to do it."

Cruise Plans: Sea of Cortez

Noteworthy: These guys have cruised up and down the coast for 20 years, but are finally breaking away on a longer cruise.

New Moon — Hunter 410

Gerald & Karen Elder

Rio Rancho NM

Occupation: Gerald, engineer; Karen, homemaker

Add'l Crew: Nick Blair, Don & Lisa Hooper, Ray Elder, Pat Williams & Kathleen Tediker

Quote: "We had such a great time last year that we just had to do it again."

Cruise Plans: TBD



Brendan and Baba (Ha-Ha '04 vets) are looking forward to some R&R aboard 'Isis'.

Noteworthy: The boat's homeport is Albuquerque and her spinnaker looks like the New Mexico state flag. This boat did the Ha-Ha last year with Club Nautique 'students' aboard.

Notre Reve — Cal 35

Tony Denardo, Santa Ynez

Occupation: phone guy (ret)

Add'l Crew: Eric Anderson & Jim Campbell

Quote: "New Year's in Acapulco or bust!"

Cruise Plans: after Mexico, on to their new homeport of Hawaii

Noteworthy: Tony has only owned this boat for two months.

Isis — Santa Cruz 52

**Brendan Busch & Barbara Muller
La Honda**

Occupation: Brendan, software; Barbara, attorney

Add'l Crew: TBD

Quote: "Life is short, cruise hard!"

Cruise Plans: cruise Mexico for six months

Noteworthy: This boat sailed previously from San Francisco to Australia. Both Brendan and 'Baba' are vets of both the TransPac and PacCup.

That's it for this installment. But there are plenty more to come. So tune in again next month.

— **latitude/at, Id & Ic**

Norman Diego's

THE MEXICAN INN

CABO SAN LUCAS

**Abasolo y 16th Septiembre
Next to the Port Captain's Office**



\$75 + TAX INCLUDES BREAKFAST!

**SPECIAL RATES
FOR BAJA HA-HA**

www.themexicaninn.com

U.S.: (866) 434-3467 • Cabo: (624) 143-4987

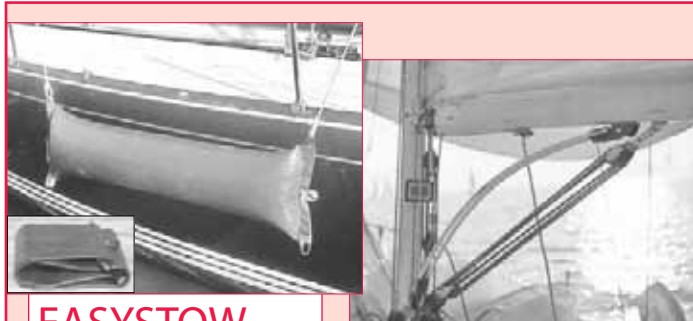

EASYSTOW FENDERS™

Replace hard to store, hard to use fender board arrangements with heavy-duty 5-ft long Easystow Fenders. Easy to use and easy to stow. 6, 8, 10 and 12" diameters. 10" diameter pictured above on 40-ft boat. Double wall tough with no longitudinal seam to catch or split. Other sizes and models available.

Boomkicker®

Boomkicker boom supports are the simple solution to eliminate the topping lift along with the chafe, windage, hangups and adjustments. Join thousands of happy customers. Simple, innovative design, easy installation, complete with fittings. For boats 14 to 38 feet. More info on the web.

www.easystowfenders.com or www.boomkicker.com
(800) 437-7654 • (708) 482-8801 • Fax (708) 482-8802

Manufactured in the U.S. by Seoladair Ltd.



Paradise Village™
MARINA & YACHT CLUB

Paradise Village Marina *...Treasure of the Gold Coast*



Share with us our Successful combination:
• *Service* • *Security* • *Location*

Services:

- Electrical service, 110/30amps, 220/50 amps and 3 phase 100amps
- Potable water
- Cable TV
- Garbage collection
- Pump-out Station
- Fire fighting boat protection
- 24 hrs. Security.
- Computerized gate access

Additional services:

- Vallarta Yacht Club
- Special area for marina guests
- Restrooms
- Showers
- Lockers
- Pool and Jacuzzi
- Free access to all the facilities of our 5 star hotel
- White sand beach
- Dive tank refilled
- Propane refill
- Launch ramp



CONTACT US:
marina@paradisevillagegroup.com
Phone & fax from U.S. 01 1-52-322-22-66728
www.paradisevillage.com



GPS Coordinates 105 17.9 W 20 41.2 N CHANNEL 16

MAX EBB

When I was in college, there was a ritual for anyone who showed up on campus with a new (to them) car: Park it right in front of the dorm cafeteria at lunchtime, so that the gang could give it a proper inspection. They would either gush with envy or deride it as a worthless heap, according to mood and circumstances.

Nothing really changes with more expensive toys. Whenever a yacht club member buys a new boat, regardless of where it's to be berthed, they tie up to the guest dock before the next dinner meeting. Of course, most of us have learned some manners over the years, so there aren't many "worthless heap" comments anymore. But we do like to gush over the fancy new rides.

The last dinner meeting was a perfect example. A long-time yacht club member had finally traded all the way up from his 27-ft plastic classic to a beautiful new 47-footer with all the options — and this boat was loaded with every gadget in the catalog. Naturally, I diverted down to the guest dock to have a look. The owners, observing proper new boat party etiquette, had put out a very nice spread of food and drink, and there was already a crowd gathered.

I sampled some pâté and poured myself a glass of wine before stepping down into the cabin. As I descended the ladder — which I couldn't help noticing had two more steps than the one on my boat — it occurred to me that, whenever a free upscale spread is offered anywhere on the waterfront, starving grad students like Lee Helm are bound to be close. Sure enough, she was right there at the chart table, with her attention divided between a big plate of sushi and a computer keyboard.

"Did it!" she exclaimed through a mouthful of raw fish as she looked up from the chart table to the giant flat-screen TV on the forward cabin bulkhead.

"The chart plotter screen is now piped over to the main cabin display. See, that's us, that's the marina outline, those things are the ships plotted by the AIS receiver . . ."

"Hey!" complained one of the other guests before Lee had finished her sentence. "What about the football game?"

"They're watching it on the other screen in the aft cabin," Lee tried to explain, but it was no use: the sports fans

wanted it on the big screen, so Lee had to demonstrate the AIS tracking features on the small nav station monitor.

Meanwhile, the owners were showing off even more gadgetry below decks and



LATITUDE / JR

above: the icemaker, the trash compactor, the watermaker, the air conditioning, the electric heads. As more early arrivals for the yacht club dinner meeting funneled into the main cabin, Lee and I decided to follow the owner upstairs to check out the deck layout and rigging.

"Roller furling. Like, yuck," sneered Lee in a whisper.

"Ah, but there's a self-tacking track too," I pointed out.

"The only jib I put on the roller is the self-tacker," explained the owner, apparently overhearing what Lee had intended for my ears only. "It's going to be my summer daysailing jib. With the self-tacker and the furler, I think it will be great for singlehanding. For light air, I have a big deck-sweeper genny I

can set flying, so I don't even have to pull the working jib down off the foil."

"Okay, I gotta admit, that's a much better deal

than the usual roller-furling 120 that's, like, too small for light air, too big for heavy air, and too short on the hoist to ever let the boat point well."

"Yeah, I had that on my last boat," added another guest. "Did a lot of power-ailing. Now I have a powerboat."



Then we turned our attention to the mainsail furling device, one of the new in-boom systems.

"This is miles better than those in-mast furling rigs," Lee allowed.

"You mean you actually like it?" I gasped.

"Totally. It doesn't slow the boat down," she said. "You can still have lots of nice long stiff battens and a big roach. I don't think it lets you adjust the outhaul very well, but cruisers, like, never touch their outhauls anyway."

"Wait till you see the electronic vang," boasted the owner. "There's a readout for the boom angle, because you have to get it just right for the in-boom furling to work."

"I was able to eyeball mine," added the powerboater. "Once you learn the proper care and feeding of these in-boom furlers, they actually work pretty well. You can tell right away as the sail rolls up if the boom height needs adjustment."



JUD BERRY

Bubble-headed blonde — Above, a future singlehander checks the set of the main. Inset, dodgers may restrict your view a little but, to many, they're required equipment.

This news didn't diminish the owner's excitement about his electronic vang meter any less but, before we could debate the point, his attention was diverted to a large mass of canvas and steel being carried toward us down the gangway to the guest dock.

"My dodger!" he exclaimed. "It's finally here! I was hoping it'd be done today."

"Sorry I'm a little late," the woman from the canvas shop apologized as she caught her breath. "Should we wait till after your party?"

"Heavens no," he said. "Let's set it up right now. ALL HANDS!" he shouted down the hatch as if calling up the off-watch for a sail change.

"I do have my people here with me to help me install it for you," the canvas shop owner explained.

It was no use. The dodger, after

months of planning and measuring, was the owner's pride and joy, and he was going to make sure all his guests saw how clever the design was and how much attention to detail he'd poured into the thing.

Twenty minutes later it was set up.

"Now I can see why he needs the digital vang readout," whispered Lee, this time making sure the owner was out of range. "With this dodger in place, you can't see a thing!"

"It sure makes a lot of protected space in the cockpit, though," I said.

"Well, yeah, but how the heck are you going to sail the boat when you can't see the sails? And look what it does to the winch grinding position," she said as she tried to crank a sheet winch from around the edge of the canvas. "And the halyard winches end up inside the dodger so, even if you can manage to see through this window when it's covered with spray,

you have to run around the long way to get from halyard control to the mast or the foredeck."

"You like the way all the halyards and reef lines lead aft?" asked the owner proudly. "It's all rigged for singlehanding."

"Um, for sure," Lee answered. "It's, like, really awesome."

Lee waited until the owner was below again before making a gagging gesture. "Why does everyone think that leading controls aft to the cockpit is good for singlehanding?" she moaned.

"Maybe because that's where the helm is?" I suggested.

"Since when do serious singlehanders spend time at the helm?" she responded. "I mean, like, any singlehander worth their bandwidth is going to have the helm wired. The sail handling is all done from the mast, where you can reach things. You know, catch sails as they come

MAX EBB

down, fix tangles, tie things off. That's the real workstation for the singlehander, and it's where all the halyards and reef lines should be controlled from."

"Ahoy, Lee! Got your text message. This must be the place!"

Another woman, apparently Lee's friend, was on the dock. Lee did not hesitate to invite her aboard and offer the owner's treats.

"Great boat," she said after a quick look and big bite of salmon eggs. "Cruising boats sure have gotten a lot better-looking in the last few years. Except this big old dodger kinda ruins the lines. It's about four times as high as the cabin trunk."

"Tell me," Lee agreed. "The designer goes to all the trouble to keep the cabin sole as low as possible, to keep the cabin profile low, to keep the windage down, and then they stick this clunky mass of backwards pushing canvas on the back. Plus it looks out of proportion. My rule of thumb is that the dodger or doghouse should never be more than twice as

high above the cabin trunk as the cabin trunk is above the deck. Like, to avoid the phone booth look if not for keeping windage within limits."

"That boat *Ruby* sets the standard for sailing phone booths," noted the powerboater.

"Well, *Ruby* is so bad it's cool," said Lee's friend. "If you have to have a wall in front of the helm, I really like solid pilothouses a lot better than dodgers. You can put things on top, you can have better windows, you can have doors that will really turn it into inside space that you can keep warm and dry, you can even have windshield wipers that work. A dodger is just a halfway measure. But I agree, they have to be proportioned right, and that doesn't mean they have to be small, it just means they have to be in the same scale as the rest of the boat's profile."

"Examples?" I asked.

"The *Derek M. Baylis* gets it right," she said. "Big comfy pilothouse, but it works. On the other hand, the pilothouse ver-

sion of that 52-ft sled gets it wrong, as much as I love those boats without the doghouses."

"Still, you wouldn't put a doghouse on a race boat," I said. "At least a dodger can be removed. Or do you think maybe those little hatch trunk dodgers are the best solutions?"

"They're better," said Lee's friend.

"But a dome is best, especially for singlehanding," noted Lee.

"You mean those funky hemispherical plastic domes that started showing up on the French singlehanded multihulls in the '60s?" asked the powerboater.

"Yes, that's the one," said Lee. "They used to be made by Goïot."

"How is that better than a dodger?"

"For singlehanding it's the only way to go," said Lee. "You can stay warm and dry and still have a look around once in a while. And you can totally see the sails better, too."

"Most boats have just enough slant to

JUST YOU AND THE SEA...

Punta Mita Beachfront Condos

Call now for winter reservations!

1.415.599.5012

www.puntamitabeachfrontcondos.com

— DUCK AND COVER

the sides of the cabin so you can see the luff of the spinnaker from a pilot berth," said Lee's friend. "But a dome gives you a way to look around without going outside."

"Remember what Blondie Hasler, founder of the singlehanded trans-Atlantic race said," noted the powerboater. "It is poor seamanship to ever get cold, wet or tired."

"He had a dome on his junk-rigged Folkboat, didn't he?" I recalled.

"I think so," confirmed Lee. "The dome is an especially good solution for small boats, because you can replace the sliding hatch (which usually leaks anyway) with a new piece of decking in which you install the dome."

Hasler had a motorcycle seat under his dome," added the powerboater. "Or was that Chichester?"

"Point is," continued Lee, "you can stay warm and dry and still be on watch, not huddled and shivering behind the

dodger on a cold night."

"But is your visibility really that good through the dome?" I asked. "I'd think it gets all splattered with salt spray and water drops just like the dodger windows. And if the boat is heeled way over, how can you get high enough to see over the windward rail?"

"Okay you still have to, like, stick your head out once in a while," admitted Lee. "Just like you have to look around or over a dodger if you really expect to see anything in front."

"Electronics goes a long way," said Lee's friend. "Although technically you still have to keep a visual watch."

The owner was back on deck, showing off the in-boom furling to some guests who were suddenly showing much more interest in the boat now that the football game was over. It was much clumsier with the dodger in the way, but he managed to use the electric halyard and sheet winches to roll the sail up and down all

by himself.

"Let's take it out for a spin!" said one of the guests.

"Yes! They won't be starting dinner up at the club for another 45 minutes. Plenty of time, especially with this auto-furling!"

The owner, groping for an excuse, couldn't come up with anything except that all the food and drinks would go flying, but Lee and her friend started a quick sweep of the cockpit and cabin and promised that everything would be battened down before the boat was out in the Bay.

Next thing we knew, we were motor-ing down the channel and into a stiff sea breeze. We pushed the right buttons and pulled the right strings — eventually — and, a few minutes later, the boat was crashing to windward. We slammed into one particularly big wave that sent gallons of cold sea water flying aft and the cockpit crowd ducking under the newest addition.

"Good thing this boat has a dodger," someone said.

— max ebb



Emeryville Marina

ON THE BAY

NEW SLIPS!
40-65' Available Now
Call Today...

*When you call Emeryville Marina Home...
...call this your backyard!*

Full Amenities
including
Fuel Dock & Pumpout Station

(510) 654-3716
www.emeryvillemarina.com

MARINAS International

THE RACING

Welcome to autumn. This month we break out the eggnog and relive an exciting September with coverage of such local events as the **International Knarr Championships**, **Windjammers**, **Sport Fest**, **Folkboat Internationals** and **BAYS Summer Series**, plus such far-flung events as the **Summer Splash**, **Rolex Maxi Worlds** and **Audi Melges 24 Nationals**. There's lots more, but we want to surprise you. Per the season, we'll top it all off with a nice spicy sprinkling of **race notes**.

International Knarr Championships

The outcome of the 39th Annual International Knarr Championships, sailed September 1-8 out of the San Francisco YC, was not decided until the final mark of the final (counting) race. On the run down to the last leeward gate, local Knarr (and J/105) maestro Chris Perkins was in third. His brother Jon was in first, but all Chris's attention was focused on the second-place boat, sailed by 2006 IKC champion Soren Pehrsson of Denmark. Perkins and Pehrsson had been trading the lead back and forth the whole week, and going into the last race on Saturday, they were separated by one point — and about one boatlength. Whoever made it around the leeward mark and into clear air first would win the series.

Jon got around fine and headed for the finish. But Soren and his all-Dane crew misjudged the current and had to wiggle a bit to keep from hitting the pin. That's the break Chris was looking for. "We just went outside in a more power-oriented turn and immediately luffed

secured their third IKC win since 1992. Pehrsson finished second overall.

Sailing with Chris were his regular *Three Girls and a Boy* Knarr crew: boat partner Hans Baldauf, brother Phil Perkins and Hisham Sinawi. But they weren't sailing *Three Girls*. The IKCs are a round robin in which each crew sails five different boats over the 10-race series — and nobody sails their own boat. The IKCs themselves shift around between San Francisco, Denmark and Norway, which also maintain strong fleets of the 1943 Danish design

Per the Deed of Gift, 25 boats race in an IKC — 12 with crews from the host country, 6 each with crews from the guest countries (Norway and Denmark this year), and 1 reserved for the former year's winner (Soren Pehrsson). Two 'breakdown' boats are also maintained at the ready (one is even sailed back and forth near the course) in case someone experiences breakage and needs to transfer to a working boat.

Ashore, the event is equally as unique, with guest skippers and crew staying in the homes of local fleet members. Lots of fleets make the claim, but the Knarrs really are one big happy family.

This edition of the IKCs was memorable for more than its cliffhanger ending and camaraderie. Big breeze figured heavily into the proceedings early in the series as the fleet battled bruising 25-30-

knot winds and chop on the Berkeley Circle in Races 3 and 4. Later on, Race 7 was postponed (and later resailed) when all the torn sails and broken spreaders threatened to prevent a sizable chunk of the fleet from even starting. Luckily,



MIKE GUZZARDO / WWW.94505.COM

Knarr meisters Chris Perkins, left, and Soren Pehrsson went down to the wire in the '07 IKCs, with Perkins taking the winning gun.

him head-to-wind," says Perkins. The fat lady serenaded Chris and his crew the whole way up the final beat where they

Al Blair's 'mobile midnight boat repair service' was in high gear at the club. Al and his team often worked well into the night to screw and glue broken boats back together in time for the next day's racing. "We just gave him a free bar chit and begged him not to leave until they were all ready to go," jokes IKC Chairman John Colver. "I don't think he left before 10 or 11 any night."

Some damage was beyond even Al's purview, at least for overnight repair. In one port-starboard confrontation, two boats locked rigs and both were dismasted — despite their hulls never actually making contact. Another two made major contact, when a port-tacker misjudged a ducking maneuver and removed most of the starboard boat's stern. Although other boats also suffered lesser forms of brutality, thankfully no sailors were injured.

Even the courses suffered a bit. A miscommunication in Race 8 saw boats

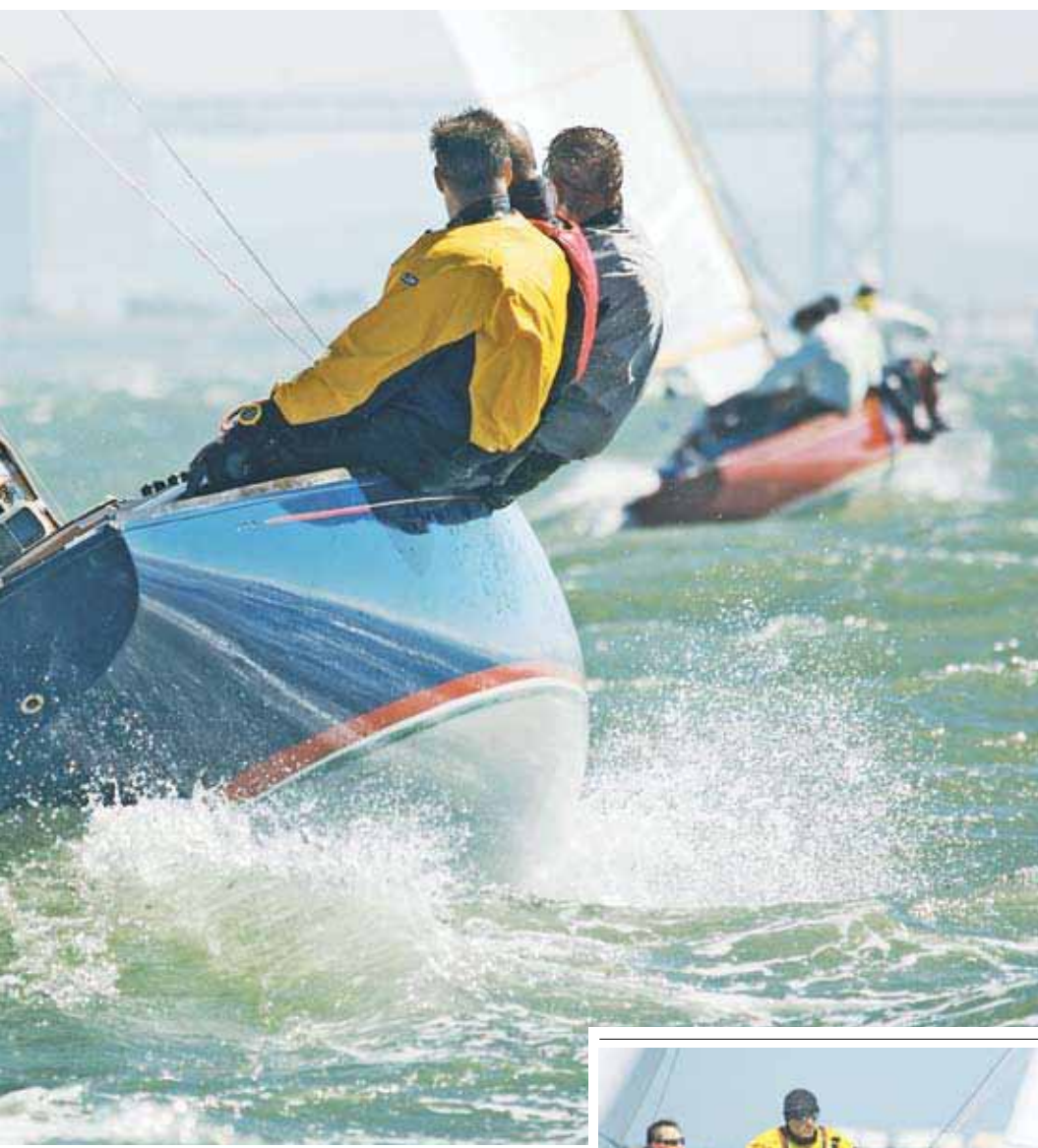

PETER LYONS / WWW.LYONSIMAGING.COM

Big breeze pummeled the IKCs midway through the series. After one particularly brutal beating on the Cityfront, they retreated to the Berkeley Circle — where it blew even harder.

trying to round the top mark in both directions, so that race was tossed. In the 10th, one of the gate marks drifted over and tangled with the other. With no 'gate', it was once again a situation of which way to round — and once again an abandonment. The '07 IKCs was thus scored on 8 races (and 1 throwout) rather than the planned 10/2.

Other local Knarr fleet members rounded out the top five this year, with Charles Griffith in third, Rick Fisher in fourth and Jon Perkins in fifth.

Next year's 40th IKCs will be sailed in Bergen, Norway, in August.

1) Chris Perkins (USA), 20 pts.; 2) Soren Pehrsson (DEN), 22; 3) Charles Griffith, 37; 4) Rick Fisher (USA), 43; 5) Jon Perkins (USA), 47; 6) Kim Bruhn-Petersen (DEN), 55; 7) Larry Drew (USA), 56; 8) Sean Svendsen (USA), 57; 9) Flemming



Christiansen (DEN), 60; 10) Johan Gustav Hvide (NOR), 73. Complete results www.knarr-sf.com/IKC2007.htm.

Windy Windjammers

The 66th running of the Windjammers Race from San Francisco to Santa Cruz was held the Friday of Labor Day weekend. Twenty-six boats in five divisions started off the St. Francis YC, with the larger boats gaining an early advantage

by getting around Land's End before max flood, while many of the smaller boats had to struggle.

The leaders, *Kokopelli*², *Ocelot*, *Octavia* and *Roller Coaster* enjoyed favorable reaching conditions all the way down the coast, only to encounter the evening easterly close to the finish line off the wharf in Santa Cruz. Kevin Flanigan's Fox 44 *Ocelot* crossed the line at 5:30 p.m., not only finishing first but overcoming her -27 PHRF rating to take both division and overall honors. Lani Spund's well-sailed turbo SC 52 *Kokopelli*² was second across three minutes later — and also ended up second in division and overall.

Once out of the Gate, the smaller boats also found good winds — sometimes too good, as there were several reports of torn sails, broken booms and one dismasting — the SC 27 *Saffron*. The race committee continued to finish boats throughout the night and into Saturday morning. The final boats ghosted in through extremely thick fog that obscured the finish line. The last boat to finish was Phil Mummah's *Gibsea 43 No-Ka-Oi* at 10:13 a.m., well before the noon deadline.

The Windjammers Race has an interesting component for those who want to be sure they make it down to Santa Cruz. The "B" fleet boats are allowed to motor for a total distance of 20 miles during the race. This feature adds more than a

little extra strategy: Do you motor at the start to get out of the Bay, wait until you encounter the light easterlies at the finish, somewhere in between — or some combination?

This year Steve Hass of the Catalina 42 *Tesa* chose most wisely. He used his engine at the start of the race to get through that nasty flood and had good sailing the rest of the

way. *Tesa* finished shortly after 8 p.m. Friday, taking both first to finish and corrected honors in Class B. Equally as important, the bar at the club was still open!

This was the first time in many years that all of the starters of the race made it all the way down to Santa Cruz. The DNFs motored in, and even the dismasted *Saffron* was towed there.

— Bob Simpkins



WINDJAMMERS RESULTS

PHRO-1A — 1) **Ocelot**, Fox 44, Kevin Flanagan; 2) **Roller Coaster**, SC 50, Jack Gordon; 3) **Octavia**, SC 50, Shep Kett. (7 boats)

PHRO-1 — 1) **Timber Wolf**, Farr 38, Dave Hodges; 2) **Spindrift V**, Express 37, Lynn and Larry Wright; 3) **Sapphire**, Synergy 1000, David Rasmussen. (8 boats, 1 DNF)

PHRO-2 — 1) **Cirque**, Beneteau 42s7, Louis Kruk; 2) **Voyager**, Ben. 345, Dean Hocking; 3) **Made Easy**, Ben. 42, James Peterson. (4 boats)

MORA — 1) **Tenacity**, SC 27, Paul Nielsen. (3 boats, 2 DNF)

CLASS B (motoring) — 1) **Tesa**, Catalina 42,

Sport Fest Fotos (clockwise from above) — John Liebenberg's always hot 'Always Friday' on the way to an Antrim 27 division win; 'E.T.' flyin' low; Antrim 27 parade; rush hour at the windward mark; Jim Carlsen's U-20 'Cloud Nine' mixes it up with the only Open 5.70 in the event, Jerome Sammarcelli's 'Chupacabric'; J/105s beat to weather.

Steve Haas; 2) **Pegasus**, J/35, Marc Sykes; 3) **Zephyra**, Morgan 41, Russ Noorda. (4 boats)

RYC Sport Fest Invitational

Richmond YC's second annual Sport Fest Invitational regatta was held August 25-26. Building on the success of last year's inaugural event, more sportboat classes were invited and more attended

the five-race weekend spent on the Berkeley Circle.

Along with the returning Antrim 27 and Ultimate 20 and 24 fleets, this year's roster included the Melges 32s, a small J/105 fleet and a single Open 5.70. Although most classes were small — the U-20s and J/105s were the largest at 7



ALL PHOTOS PATRICK GREY/WWW.PGREY.SMUG.MUG.COM

and 8 boats, respectively — all 29 participants in the five-race, no-throwout series enjoyed great racing, terrific race management (headed by PRO Del Olsen) and first-class dining and entertainment at the Saturday night festivities.

The idea for an all-sportboat regatta was conceived last year during the Antrim Nationals, and RYC is hoping the Sport Fest will become a 'must-do' staple of the yearly racing calendar. Held last year in September, this year's August dates were picked not only for the typi-

cally higher winds, but also to act as a precursor to the Rolex Big Boat Series. (Only the J/105s and Melges 32s actually went on to race in BBS.)

Big breeze on Saturday felled two masts in the Ultimate 20 class before mellowing out on Sunday. In the final two races, Tim Burden and Trish Sudell on *Layla* got past Trent Watkins' well-sailed *UFO* to win that division. Over in the J/105s, it came right down to the final race before Bennett Greenwald's *Chile Pepper* squeaked by Adam Spiegel's

Jam Session with just a point to spare.

Dates for next year's Sport Fest Invitational have not been announced, but will likely once again fall on or near the last weekend in August. It is mainly aimed at asymmetrical-kite boats, so if your class doesn't get invited, be a squeaky wheel and let them know you're interested in attending one of the coolest new events on the Bay. For more information, visit www.richmondyc.org.

OPEN 5.70 — 1) **Chupacabric**, Jerome Sammarcelli, 5 points. (1 boat)

THE RACING

ANTRIM 27 — 1) **Always Friday**, John Liebenberg, 7 points; 2) **Cascade**, Steve Reinhart, 14; 3) **E.T.**, Liz Baylis, 16. (5 boats)

MELGES 32 — 1) **Taboo**, Steve Pugh, 10 points; 2) **Stewball**, Caleb Everett, 12; 3) **Southern Cross**, Richard Leslie, 12. (3 boats)

ULTIMATE 20 — 1) **Layla**, Tom Burden/Trish Sudell, 9 points; 2) **UFO**, Trent Watkins, 13; 3) **Cinderella Story**, John Andrew, 16. (7 boats)

ULTIMATE 24 — 1) **Vuja De**, Chris Kim, 7 points; 2) no name, Peter Cook, 10. (2 boats)

J/105 — 1) **Chile Pepper**, Bennett Greenwald, 10 points; 2) **Jam Session**, Adam Spiegel, 11; 3) **Wallopig Swede**, Theresa Bradner-Allen, 18. (8 boats)

Full Results — www.richmondyc.org

Shields Trophy

For the fourth time in the last five years, the California Maritime Academy has captured the prestigious Shields Trophy in sailing competition at the U.S. Naval Academy. In two days of competition against teams from Navy, the Coast Guard, King's Point Merchant Marine Academy, St. Mary's college and maritime academy entries from Massachusetts, New York, Maine and the Great Lakes, the Cal Maritime crew emerged triumphant.

The Shields Trophy format involves a series of races, all using Navy 44 sloops supplied by the Naval Academy. "We finished in the top three in every one of the seven events," said Academy coach Susan 'Charlie' Arms. "We had a fouling mishap in the first race which cost us some penalty points, but after that we were solid from start to finish. In the final races, we had a strong lead, allowing us to play defense against our closest com-



shore team includes four freshmen (Tyler Wolk, Evan Wanamaker, Katy Love and Bryan Buffaloe), and three sophomores (Robert Proulx, Charles Davis and Brian Vanderspek) along with senior Nathan Prather.

What made the victory even more amazing is that the Cal Maritime team had virtually no time to practice aboard the 44s before racing began on Saturday. The only times they'd sailed together as a crew before were in a few tryout and practice sails locally.

The next big racing event on the Academy's fall schedule will be the Kennedy Cup Intercollegiate Offshore series on November 2-4. This is also sailed out of the Naval Academy. "That's a very big event for collegiate sailing, and we'll be competing against top schools with strong sailing teams such as Navy, King's Point and the University of Rhode Island. It will be a good test of just how strong the 2007-08 Cal Maritime offshore crew really is. In the past two years, we've finished second in the Kennedy Cup to URI and Navy respectively, and we have strong

Denmark's Ditte Andreasen — the only woman skipper in the IRNF — in the heat of battle.

hopes for taking the top prize this year. We're excited."

— doug webster



Cal beats Navy! Shields Cup winners (l to r) — Evan Wanamaker, Katie Love, Tyler Wolk, Brian Vanderspek, Thor Proulx, Cole Davis, Nathan Prather (holding glass), Bryan Buffaloe.

petitors to make sure we didn't foul or get forced over the starting line early."

The 2007 Academy eight-person off-

You readers know who loves ya, right? So you know we'd really like to give every race the coverage it deserves. Alas, we are mortal. So for the following events, you'll just have to settle for results.

YRA-ODCA SEASON STANDINGS:

BENETAU FIRST 36.7 — 1) **Mistral**, Ed Durbin, 40 points; 2) **Ay Caliente**, Aaron Kennedy, 49; 3) **Bufflehead**, Stuart Scott, 50. (5 boats).

ALERION EXPRESS 28 — 1) **Eagle**, Chuck Eaton, 10 points; 2) **Lizabeth**, Michael Land, 15; 3) **Scrimshaw**, Michael Maurier, 20. (6 boats).

ANTRIM 27 — 1) **Cascade**, Steven Reinhart, 10 points; 2) **Always Friday**, John Liebenberg, 13; 3) **Max**, Ryan Richard, 14. (4 boats).

SF 180 — 1) **Goose**, Michael Kastrop, 13 points; 2) **Harry**, Richard Aronoff, 17; 3) **Achates**, Bob Schock, 2. (8 boats).

EXPRESS 37 — 1) **Elan**, Bill Reiss, 18 points; 2) **Golden Moon**, Richards/Bridge, 20; 3) **Expeditious**, Bartz Schneider, 28. (7 boats).

ISLANDER 36 — 1) **Windwalker**, Shoenhair/



PETER LYONS / WWW.LYONSIMAGING.COM

International Regatta for Nordic Folkboats

Local sailor David Wilson and his crew triumphed over a tough 18-boat field in the 2007 International Regatta for Folk-

boats, which was sailed out of San Francisco YC the week of September 16-22. In addition to eight Americans, sailors from Germany, Denmark, the Netherlands, Great Britain and Sweden took part.

Although the IRNF might sound a bit like the International Knarr Championships, which were held in late August — the two fleets do share histories dating to the 40s and lots of international camaraderie — the Folkboat event is set up differently. Rather than a round robin like the IKCs, visiting Folkie sailors are assigned one boat to use for the entire seven-race, no-throwout series (barring breakdowns, for which the fleet maintains three reserve boats). They bring their own sails (and sail numbers), and Danish champion Per Buch even brought his own boat! (*Josephine* was sold after the races and will remain on the Bay.) Local sailors are also allowed to use their own boats.

Wilson has grown up aboard Folkboats, which his father Don has been racing

for the last 39 years. In fact, Don would have been steering #106, *Windansea*, himself if he weren't recovering from shoulder surgery. So David and friends Tom Urbania, Martin Leivers and Paola DeCecco took the reins. (Paola crewed on the first two days; Tom, who flew in from Washington, DC, crewed the rest of the week).

"The first race turned out to be key for us — even though we didn't plan it that way," says David. "We got stuck heading for the left side of the course. We wanted to tack but couldn't. Turns out a bunch of boats followed us over there. When we finally managed to tack, the other lefties kept going and really got hosed."

One of those was German Folkboat champion Christoph Nielsen, who took a 13th in Race 1, then a 7th in Race 2. After that, he approached Don Wilson, who was on the technical committee — and asked for another mast.

"You don't get requests like that too often," says the elder Wilson. "But he was adamant that the mast that was in the boat was too flexible at the bottom and that every time the boat hit a wave, it shook the wind out of the luff.

"I've been sailing these boats for almost 40 years and had never heard of such a thing. But you know what? We took a mast out of one of the reserve boats, put it in Christoph's and he won the next three races!"

By that time, David and his crew had a near headlock on first, ahead of even Folkboater extraordinare (and 2005 champ) Peter Jeal. But coming down to

BOX SCORES

Gilliom, 16 points; 2) **Captain Hooke**, Tom & David Newton, 25; 3) **Pacific High**, Harry Farrell, 31. (12 boats).

PC J/105 — 1) **Walloping Swede**, Theresa Bradner, 15 points; 2) **Taboo**, Laby/Pipkin/McGrath, 19; 3) **Ultimatum**, Musto Gunan, 23. (7 boats).

OLSON 25 — 1) **Vivace**, Larry Nelson, 19 points; 2) **Clean Sweep**, Tom Nemeth, 36; 3) **Synchronicity**, Steve Smith, 40. (10 boats).

OLSON 30 — 1) **Hoot**, Andrew Macfie, 25 points; 2) **Voodoo Child**, Charles Barry, 34; 3) **Naked Lady**, Jeffrey Blowers, 44. (5 boats).

SANTANA 22 — 1) **Tackful**, Frank Lawler, 36; 2) **Carlos**, Jan Grygier, 38; 3) **Tchoupitoulas**, Buckingham/Giovacchini, 42. (12 boats).

Full results — www.yra.org

COLUMBIA 5.5 NATIONALS (EYC, 8/26; 5 races):

1) **Maverik**, Bill Colombo, 8 points; 2) **Sea Biscuit**, Stephen Hutchinson, 12; 3) **Wings**, Mike Jackson, 19; 4) **Alert**, Liem Dao, 20; 5) **Tenacious**, Heather Sadeg, 25; 6) **Jaguar**, Keith Rarick, 26; 7) **Faith**, Bill Canepa, 30. (7 boats).

Full results — www.encinal.org

INTERNATIONAL 18 SKIFF REGATTA

(StFYC, 8/21-25; 10 races):

1) **Pegasus**, Howie Hamlin, 8 points.; 2) **Yandoo**, John Winning, 14; 3) **Delonghi**, Grant Rollerson, 24. (9 boats).

Full results — www.stfyc.com

RONSTAN BRIDGE TO BRIDGE (StFYC, 8/24; 1 race):

18' SKIFF — 1) **Pegasus**, Howie Hamlin, 1 point; 2) **Delonghi**, Grant Rollerson, 2; 3) **TMF**, Pat Whitmarsh, 3. (8 boats).

FORMULA — 1) **S 3**, Steve Sylvester, 1 point; 2) **ML**, Mike Zajicek, 2; 3) **USA VYV**, Mike Percey, 3. (11 boats).

KITE — 1) **Yellow 3**, Chip Wasson, 1 point; 2) **Yellow 4**, Anthony Chavez, 2; 3) **Yellow 0**, Gabe Brown, 3. (17 boats).

Full results — www.stfyc.com

YRA-HDA KNOX/BONITA (CYC, 9/8; 1 race):

DIV. G (<111) — 1) **Velocita**, Mumm 36, Mueller/Christle, 1 point; 2) **Two Scoops**, Express 34, Chris Longaker, 2; 3) **No Name**, Ultimate 24 ODR, Peter Cook, 3. (5 boats).

DIV. D (SF 30) — 1) **Wishful Thinking**, Tartan 10, Lester Gee, 1 point; 2) **Encore**, Wylie Gemini 30, Andy Hall, 2; 3) **Elusive**, Olson 911S, Charles Pick, 3. (9 boats).

DIV. K (>114) — 1) **Eclipse**, Hawkfarm 28 ODR, Fred Hoffman, 1 point; 2) **Latin Lass**, Catalina 27 IB, William Chapman, 2; 3) **Mon Desir**, Jeanneau Sun Odyssey Fast, Jerry Nassoij, 3. (8 boats).

ALERION EXPRESS 28 — 1) **Lizbeth**, Michael Land, 1 point; 2) **Eagle**, Chuck Eaton, 2; 3) **Arabella**, Harry Allen, 3. (7 boats).

Full results — www.yra.org

SSS EAST BAY ESTUARY RACE (9/8; 1 race):

SINGLEHANDED

CLASS 2 (PHRF <99) — 1) **Arowana**, Diva 39, Larry Riley; 2) **Moonbuster**, S&S 47, Wayne Meretsky; 3) **Tiger Beetle**, N/M 45, Rob MacFarlane. (3 boats).

CLASS 3 (PHRF 100-160) — 1) **Red Sky**, Olson 34, Brian Boschma; 2) **Solar Wind**, Martin 32, Max Crittenden. (2 boats).

CLASS 4 (PHRF >161) — 1) **Travieso**, Ericson 30, Daniel Alvarez; 2) **Emerald**, Yankee 30,

THE RACING

the finish of the last race, the wind died and the *Windansea* crew started sweating. They seemed glued to the water within yards of the finish as other boats started passing, finally drifting across in 8th — but still 9 points ahead of second-place Jeal. "By the last day it was pretty hard to lose, but we did our best," laughs David.

As counterpoint to the 7th-race drifter, Race 3 on the Knox course was sailed in nuclear breeze that topped 30 knots in the gusts. Carnage included one dismasting in a port-starboard altercation, and one 'dis-ruddering' in an overtaking incident. Considering the potential for more of the same to boats and people, PRO Matt Jones wisely decided to cancel the second race of the day while everyone still had all their fingers. It was resailed as a third race on Friday.

But perhaps the biggest excitement of the regatta occurred during Race 1 when a call of 'man overboard' echoed on everyone's radio. On the Dutch entry #773, a spinnaker pole snapped in half. (The Folkboats don't use spinnakers, but pole their jibs out downwind.) Bowman Ad Bastiaans grabbed the half still attached to the sail and tried to hold the sail out. But the boat rocked, and he rolled — right over the side. Fortunately, he was able to grab ahold of a shroud and

haul himself back aboard none the worse for wear. In between races, another pole was volunteered and accepted, but the stoic Dutchman refused dry clothes.

For what it's worth, 16 of the 18 Folkboats in attendance had fiberglass hulls (which were first built by local Folkboat 'godfather' Sven Svendsen in the 1970s). But the other two woodies were hardly 'disadvantaged.' #95 (from whose hull the glass molds were taken) has won this event three times over the years, and #76 is a multiple local season champion.

1) **106**, David Wilson (USA), 22 points; 2) **113**, Peter Jeal (USA), 27; 3) **658**, Christoph Nielsen (GER), 30; 4) **109**, Michael Goebel (USA), 37; 5) **907**, John Wulff (DEN), 42; 6) **926**, Per Buch (DEN), 45; 7) **534**, Johan Hellman (NDR), 59; 8) **718**, Stuart Watson (GBR); 9) **1130**, Ditte Andreassen (DEN), 61.7; 10) **112**, Bill DuMoulin (USA), 61.7; 11) **111**, Tom Reed (USA), 67; 12) **1358**, Donald Bratt (SWE), 73; 13) **108**, Chris Herrmann (USA), 74; 14) **1305**, Bengt Jarfelt (SWE), 89; 15) **852**, Robert Winkler (GER), 91; 16) **773**, Hylke Stokvis (NDR), 108; 17) **107**, Richard Keldson (USA), 119; 18) **121**, Brock de Lappe (USA), 123.

Note: boats were recognized by number, not name. Visiting crews used their 'home' numbers.

Indian Summer Splash 2007

"Sailing is too important to be taken seriously" was the motto for the '07 Indian Summer Splash, a Southern California series for multihulls held



September 14-16. It also might be the life script for Mike Leneman, who's taught Oceanography and Marine Science at Cal State Northridge for 30 years, and whose Venice-based Multimarine has sponsored the event for the last 9 years.

The Splash is a three-day event that sees the fleet race from the mainland to Cat Harbor, Catalina, on Friday, and from Cat Harbor back to the mainland

BOX SCORES — cont'd

Peter Jones; 3) **Sailfish**, Merit 25, Lee Parsons. (5 boats).

CLASS 5 (Non-spin) — 1) **Catwalk**, Pearson Ariel, Scott Wall; 2) **Svenska**, Peterson 34, Fred Minning; 3) **Even Keel**, Catalina 320, William Meloy. (7 boats).

SPORTBOAT — 1) **Mirage**, Black Soo, Ben Mewes; 2) **Taz!!**, Express 27, George Lythcott. (3 boats).

DOUBLEHANDED

WYLIECATS(30) — 1) **Uno**, Wyliecat 30, Steve Wonner. (1 boat).

DIV. D — CLASS 1 (Multihull) — 1) **Roshambo**, Corsair F-31, Darren Doud. (1 boat).

CLASS 2 (PHRF <99) — 1) **Outsider**, Azzura 310, Greg Nelsen; 2) **Cirque**, Beneteau 42S7, Louis Kruk; 3) **Pegasus**, J/35, Marc Sykes. (3 boats).

CLASS 3 (PHRF 100-160) — 1) **Bad Puddy Cat**, C&C 37, Matt Siddens; 2) **Pain Killer**, J/80, Eric Patterson; 3) **Harp**, Catalina 38, Mike Manix. (8 boats).

CLASS 4 (PHRF >161) — 1) **Speed Racer**, Merit 25, Teresa Scarpulla; 2) **Sagitta**, Islander 28, Walter George; 3) **Double Agent**, Merit 25, Robin Ollivier. (3 boats).

CLASS 5 (Non-spin) — 1) **Q**, Schumacher 40, Glenn Isaacson; 2) **Leilani**, Cal 40, Jay Capell; 3) **True North**, Baltic 42 DP, Jeff Dunnavant. (5 boats).

SPORTBOAT — 1) **Kwazy**, Wylie Wabbit, Colin Moore; 2) **1st Impression**, SC 27, Rick Gio; 3) **Le Flying Fish**, Moore 24, Sirey/Plihon. (9 boats).

Full results — www.sfbayss.org

CORINTHIAN CHALLENGE (CYC, 9/15; 1 race):

DIV. 1 (>30-ft) — 1) **Basic Instinct**, Elliot 1050, Jan Borjeson; 2) **Windhover**, Pearson 10M, John Dodge; 3) **Aria**, Grand Soleil 37, Dan Carrico. (7 boats).

DIV. 2 (<30-ft) — 1) **Tension II**, Cal 20, John Nooteboom; 2) **Chica**, Cal 20, Ted Goldbeck; 3) **Supercalifragilistic**, Harbor 20, John Colver. (4 boats).

Full results — www.cyc.org

MELGES SPORTBOAT REGATTA

(TYC, 9/8-9; 8-10 races):

MELGES 32 — 1) **Pegasus**, Philippe Kahn, 24 points; 2) **Taboo**, Stephen Pugh, 29; 3) **Fast Forward**, Tad Fairbank, 32, 4) **Southern Cross**, Richard Leslie, 34; 5) **Stewball**, Caleb Everett, 35. (5 boats).

MELGES 24 — 1) **Smokin'**, Kevin Clark, 8 points; 2) **Nothing Ventured**, Tom Klenke, 19; 3) **Jam Jam**, Neal Ruxton, 24; 4) **Bones**, Harf/Farkas, 29. (4 boats).

Full results — www.tyc.org

JOAN STORER REGATTA (TYC, 9/9; 1 race):

DIV. 1 — 1) **Joyride**, J/105, Stern/Hoehler; 2) **Arcadia**, Santana 27, Ruth Suzuki; 3) **Frenzy**, Moore 24, Alice Martin; 4) **Stink Eye**, Laser 28, Christine Weaver. (4 boats).

DIV. 2 — 1) **Galante**, Folkboat, Evie Ashcroft; 2) **Red Hawk**, Hawkfarm, Shirley Vaughan; 3) **Wind Dance**, Cal 2-27, Monique Domis; 4) **Sweet Ness**, Olson 25, Nesrin Bosoz; 5) **Quill**, Ranger 23, Tiffany Norte; 6) **Meritime**, C&C 30, Kate Proctor. (6 boats).

Full results — www.tyc.org

YRA-OYRA SOUTHERN CROSS (9/22; 1 race):

MORA (<31.5-ft) — 1) **CL2**, Cal 25-1, Dylan Benjamin, 1 point; 2) **Always Friday**, Antrim 27, John Liebenberg, 2. (2 boats).

PHRO1A (PHRF<0) — 1) **Serena**, Thompson 30, Dave Kuettel, 1; 2) **Emily Carr**, SC50, Ray Minehan, 2. (2 boats).

PHRO1 (>32-ft) — 1) **X-Dream**, X-119, Steen Moller, 1; 2) **Petard**, Buck/Newell, Farr 36, 2; 3) **Stray Cat Blues**, J/35, Bill Parks, 3. (4 boats).

PHRO2 (>32-ft) — 1) **Cirque**, Beneteau 42S7, Louis Kruk, 1; 2) **Voyager**, Beneteau 345, Steve Hocking, 2; 3) **No Ka Oi**, Gibsea 43, Phil Mummah, 3. (3 boats).

SHS — 1) **Eyrie**, Hawkfarm 28, Petroka/Seaberg, 1; 2) **Speed Racer**, Merit 25, Teresa Scarpulla, 2; 3) **Tenacity**, SC27, Paul Nielsen, 3. (5 boats).

Full results — www.yra.org

WOSSER CUP REGATTA (SFYC, 9/23; 2 races):

SPIN — **Yucca**, 8-M, Hank Easom, 4 points; 2) **306 LP**, IOD, Davies/Dailey, 6; 3) **Boog-A-Loo**,



ELECTRONIC / RICHARD

The Summer Splash fleet rounds the back side of Catalina.

on Sunday. Saturday is set aside for an educational hike along the shoreline, led by Leneman; a seminar on all things multihulls; a 'design and build your own dinghy sail from a sheet of plastic then race it' race; a sumptuous cookout at Buffalo Park on the Isthmus; and finally,

a Buffalo Stomp at Two Harbors Bar.

Twenty-six multihulls of assorted performance potential gathered off Marina del Rey for the start of the first race on Friday. It was an impressive sight, but not the entire Splash complement. Another seven multihulls were simultaneously starting from Los Angeles Harbor, plus two more from Ventura Harbor. Put them all together, and it was the largest

current offshore multihull race in North America. The event is open to everyone with an offshore multihull. No membership or allegiance is required, nor are the results reported to ORCA, the official Southern California multihull association.

This was not to suggest that no competitive juices flowed. Although there were only 8 to 10 knots of wind, the first boats crossed the 30.5-mile distant Cat Harbor finish line (on the back side of the island) just five hours later. Sunday's race featured peekaboo sunshine and a variable start. Fortunately, the wind filled in from the northwest at noon, and some 19 miles from Marina del Rey the multihulls were able to set chutes.

Racing fun, camaraderie and education all in one — that's the Splash. If you have an offshore multihull, why not participate next year?

— virginia cross

SATURDAY — 1) **See Ya**, F/C-31, Jim Ellis; 2) **Phat Cat**, Firebird, Chris Slagerman; 3) **Triple Tap**, F/C-31, Chuck Vanderboom. (10 boats)

SUNDAY — 1) **Phat Cat**; 2) **Elle**, L-7, David Ligata; 3) **Nick's Boat**, L-7, Nick Pike. (9 boats)

BAYS Summer Series

Bay Area Youth Sailing (BAYS) summer race series concluded over Labor Day weekend at Tiburon YC, who hosted the fifth and final regatta. A highlight

Cal 29, Yost/Rogers, 10. (21 boats).

NON-SPIN — 1) **QE3**, Tartan 10, Perot/Mitchell, 3; 2) **Q**, Schumacher 40, Glenn Isaacson, 4; 3) **Fast Friends**, Santana 35, Smith/Elliott, 5. (12 boats).

Full results — www.sfyc.org

H.O. LIND SERIES STANDINGS (TYC; 8 races):

SPIN — 1) **Joyride**, J/105, Bill Hoehler, 9 points; 2) **Twoirrational**, Moore 24, Anthony Chargin, 30; 3) **Moore Than A Woman**, Moore 24, Andy Poggio, 36. (8 boats).

NON-SPIN — 1) **Red Hawk**, Hawkfarm, Sullivan/Gunn, 10; 2) **Galante**, Folkboat, Otto Schreier, 16; 3) **Wind Dance**, Cal 2-27, Ann Watson, 18. (5 boats).

Full results — www.tyc.org

JUDSON-BAXTER SERIES (Presidio YC; 6 races):

OVERALL — 1) **Jazzman**, Ranger 26, Louis Canotas; 2) **HHS Bliss**, Catalina 27, Jack Gordon; 3) **Echo**, Catalina 30, Bob Hallin.

Full results — www.presidioyachtclub.org

BAMA INTERCLUB SERIES (6 races):

SPINNAKER (<142) — 1) **Vitesse Too**, Grant Hayes, 8 points; 2) **Crinan II**, Bill West, 13; 3) **Galatea**, Ken Viaggi, 13. (5 boats).

SPINNAKER (>143) — 1) **Flotsam**, Michael Tosse, 8; 2) **Spindrifter**, Paul Skabo, 14; 3) **Wind**

Dragon, Dave Davis, 15. (8 boats).

CATALINA 34 — 1) **Queimada**, David Sanner, 8; 2) **Crew's Nest**, Ray Irvine, 11; 3) **Casino**, Bill Eddy, 13. (9 boats).

NON-SPIN (<149) — 1) **Flyer**, John Diegoli, 10; 2) **Tesa**, Steve Haas, 15; 3) **Mimiya**, Mark Koehler, 16. (8 boats).

NON-SPIN MONO — 1) **Dominatrix**, Ted Crum, 9; 2) **La Maja**, Ken Naylor, 12; 3) **Knotty Sweetie**, Gerald Johnson, 17. (6 boats).

MULTI-HULL — 1) **Three Sigma**, Chris Harvey, 7; 2) **Wingit**, Amy Wells, 16; 3) **Origami**, Ross Stein, 17. (11 boats).

Full results — www.sfbama.org

FOX HAT RACE (TYC, 8/25; 1 race):

DIV. A — 1) **Frenzy**, Moore 24, Lon Woodrum; 2) **Miss Demeanor**, J/105, Aidan Collins; 3) **US 101**, Moore 24, Rudy Salazar. (3 boats).

DIV. B — 1) **Himajin**, Harbor 25, Aaron Cooperband; 2) **Don Wan**, Santana 28, Don Kunstler; 3) **Red Hawk**, Hawkfarm, Sullivan/Gunn; 4) **Siento el Viento**, C&C 29, Ian Matthew; 5) **Meritime**, C&C 30, Gary Proctor; 6) **Wind Dance**, Cal 2-27, Ann Watson. (6 boats).

Full results — www.tyc.org

YRA-ODCA Cityfront (OYC, 8/25; 2 races):

RACE 1

BENETEAU FIRST 36.7 — 1) **Mistral**, Ed

Durbin; 2) **Bufflehead**, Stuart Scot; 3) **Serendipity 2**, Thomas Bruce. (5 boats).

SPIN SF 180 — 1) **Harry**, Dick Aronoff; 2) **Goose**, Michael Kastrop; 3) **Missy B**, Russell Calvery. (8 boats).

ISLANDER 36 — 1) **Windwalker**, Shoenhair/Gilliom; 2) **Pacific High**, Harry Farrell; 3) **Blue Streak**, Donald Schumacher. (12 boats).

OLSON 25 — 1) **Vivace**, Larry Nelson; 2) **Synchronicity**, Steve Smith; 3) **Clean Sweep**, Tom Nemeth. (10 boats).

OLSON 30 — 1) **Hoot**, Andy Macfie; 2) **Hush**, Greg Gorsiski; 3) **Naked Lady**, Jeff Blowers. (5 boats).

SANTANA 22 — 1) **Carlos**, Jan Grygier; 2) **Tackful**, Frank Lawler; 3) **Elaine**, Pat Broderick. (12 boats).

RACE 2

BENETEAU FIRST 36.7 — 1) **Mistral**, Ed Durbin; 2) **Bufflehead**, Stuart Scott; 3) **Serendipity 2**, Thomas Bruce. (5 boats).

OLSON 25 — 1) **Vivace**, Larry Nelson; 2) **Synchronicity**, Steve Smith; 3) **Clean Sweep**, Tom Nemeth. (10 boats).

OLSON 30 — **Hoot**, Andy Macfie; 2) **Dragon-song**, Sam McFadden; 3) **Hush**, Greg Gorsiski. (5 boats).

SANTANA 22 — 1) **Carlos**, Jan Grygier; 2) **Inshallah**, Shirley Bates; 3) **Tackful**, Frank Lawler. (12 boats).

Full results — www.yra.org

THE RACING

for the young sailors was having Olympic Skiing Gold Medalist Jonny Moseley hand out the awards. The youngsters had near perfect conditions for the race; light to medium winds and loads of sunshine.

Classes included 420s, CFJs, Lasers, Laser 4.7s, Laser Radials and Optis. There were many awards to be coveted including the Paul Cayard, Russell Silvestri, John Kostecki and Pam Healy Perpetual Trophies.

BAYS serves as a medium in which existing and aspiring junior sailing programs in the region can cooperate on events to create large-scale tournaments. It also helps families identify potential grants and coordinate clinics to prepare young sailors to compete at a regional, national or international level. For more information visit www.tyc.org.

420 — 1) Brian Malouf/Matt VanRensselear; 2) Lindsay Grove/Kelsi Schoenrock; 3) Michael



Olympic gold medalist Jonny Moseley (the tall one in back) handed out the awards at the BAYS Summer Series. How cool was that!?

Grove/Alex Delle

CFJ — 1) Mike Deady/Keely Haverstock; 2) John Gardner/Colin Averill; 3) Ted Netland/Ellie Glenn

LASER — 1) Chris Humphreys; 2) Connor Leech; 3) Thomas Maher

LASER 4.7 — 1) Mariana Sosa-Cordero; 2) Domenic Bove; 3) Tom Parker

LASER RADIAL — 1) Jessica Bernhard; 2) Cody Young; 3) Megan Hayes

OPTI — 1) Lauren Cefali; 2) Will Cefali; 3) Lindsay Willmor

Audi Melges 24 Nationals

West Coast drivers dominated the early going at the 2007 Audi Melges 24 U.S. National Championships, which were hosted by Detroit's Bayview Yacht Club and sailed on Lake St. Clair September 21-23. Fifty-two 'varsity' boats and 21 mostly local Corinthians sailed an eight-race, one-throwout series. Breeze varied from 5-15 knots (and from pretty much every point of the compass) over the course of the racing.

In the first race, San Diego's Bill Hardesty and Huntington Beach's Mark Ivey took first and third, respectively, driving each of two *Lightwave* team boats owned by Rhode Islander David Ford. Driving Scott Holmgren's Oklahoma-based *Rosebud* to a second and third in Races 2 and 3 was Southern California

SHEILA MAHER



SVENDSEN'S METAL WORKS

CUSTOM METAL FABRICATION

SVENDSEN'S METAL WORKS is your source for top-quality marine metal fabrication. Custom designs are our specialty — and customer satisfaction is our #1 priority.

PULPITS & RAILS • RADAR ARCHES • STANCHIONS
BOW ROLLERS • LIFTING ARMS & DAVITS
BOARDING LADDERS • HANDRAILS • CUSTOM FITTINGS

VISIT OUR FABRICATION CENTER IN THE ALAMEDA MARINA.
DOCK SPACE IS AVAILABLE FOR IN-WATER REPAIRS.



SVENDSEN'S
BOAT WORKS

THE BAY AREA'S ONE-STOP LOCATION FOR MARINE PRODUCTS AND BOAT REPAIR!

Located in the Alameda Marina • 1851 Clement Avenue • Alameda, CA 94501

METAL WORKS: 510.864.7208 • BOAT YARD: 510.522.2886

www.svendsens.com

sailmaker — and reigning Melges 24 World Champion — Dave Ullman.

But there was no denying Lake Geneva (Wisconsin) sailor Brian Porter, who has been nipping at Ullman's heels for a long time. "We were 1-2 at the Worlds, 1-2 at the North Americans, and now we're 1-2 here, with Brian getting the win," said Ullman. "Those guys are just so fast and so good — they're always solid."

Porter's crew included Melges Performance Sailboats President Harry Melges III as well as company VP Andy Burdick, another Wisconsinite. Lake St. Clair is infamous for shifty breeze and seemed especially moody for the Nationals. "The lake would just fake you out in between regular shifts," said Porter. "The only solution was speed."

Local Detroit sailor Chuck Holzman, with Bora Gulari driving, won the 21-boat Corinthian division.

MELGES 24 NATIONALS — 1) **Full Throttle**, Brian Porter, Lake Geneva, WI, 33 points; 2) **Rosebud**, Scott Holmgren/Dave Ullman, Edmonton, OK, 36; 3) **WTF** (USA 587), Alan Field, Los Angeles, 38; 4) **Lightwave Nano**, David Ford, Bristol, FL, 39; 5)



LATTITUDE / JR

Santana 22s in action at Southampton during the season closer on September 9.

Gannet, Othmar Blumencron, Great Falls, VA, 44. (52 boats)

Jazz Cup

While many Bay sailors took advantage of the long Labor Day weekend to race to lovely Santa Cruz in the Windjammers, 87 boats in 11 divisions turned out in ideal sunbathing conditions to race to equally lovely Benicia in the Jazz Cup on

August 28.

Co-hosts South Beach YC and the Benicia YC put on a fine event in which spinnaker, non-spinnaker, sportboat, multihull and one design fleets alike made their way up the Delta. Light to moderate SSW winds prevailed, along with very hot temperatures. Needless to say, the no-host bar, live band, free snacks and a BBQ dinner were as well received as the lovely weather.

Liga Hoy's J/109 *Crazy Diamond*

See us at Annapolis

FAST, FUN, AFFORDABLE

THE RACING

corrected out for first in division and overall. But perhaps the most notable performance was put in by Brian McDonald, the first-ever windsurfer to do a Jazz Cup. Brian ended up 69th. In case you're wondering, his sailboard rated 99.

SPINNAKER (< 74) — 1) **Crazy Diamond**, J/109, Liga Hoy; 2) **J-World**, J/120, Frank Glassner; 3) **Bodacious**, Farr 40 1-T, John Clauser; 4) **Outsider**, Azzura 310, Greg Nelsen; 5) **Quiver**, N/M 36, Jeffrey McCord. (14 boats)

SPINNAKER (75-99) — 1) **Yucca**, 8-Meter, Hank Easom; 2) **Chilaxn**, J/105, Tim Merrill; 3) **Axel Heyst**, Primrose 50, Jim Wallis. (11 boats)

SPINNAKER (100-135) — 1) **Arcadia**, Custom Santana 27, Gordie Nash; 2) **Bluefin**, Santana 35, Noble Griswold; 3) **Fire Drill**, Tartan 10, Serge Blisson. (9 boats)

SPINNAKER (136-179) — 1) **Chorus**, Kettensburg 38, Peter English; 2) **Travieso**, Ericson 30+, Dan Alvarez; 3) **Chesapeake**, Merit 25, Jim Fair; 4) **Stolen**, J/24, Eric Mickelson; 5) **Kelika**, Hunter 33.5, Mike Weaver. (16 boats)

SPINNAKER (> 180) — 1) **Star Ranger**,



'Fire Drill' crew practiced their tai chi on their way to third in division at the Jazz Cup.

Ranger 26, Simon James; 2) **Yippee!**, Ranger 23, John Wright; 3) **Don Wan**, Santana 28, Don Kunstler. (8 boats)

NON-SPINNAKER — 1) **Pearl**, 1932 gaff sloop, Nick Haines; 2) **Spirit of Bombay**, Santana 35, Jon Rolien; 3) **Triton**, Hunter 30, Bernard Flynn.

(6 boats)

SPORTBOATS — 1) **Backatcha Bandit**, Thompson 650, Ben Landon; 2) **Vuja De**, Ultimate 24, Chris Kim; 3) **Sand Dollar**, Mumm 30, Erich Bauer. (11 boats)

MULTIHULLS (exc. F/24) — 1) **Adrenaline**, D-Class cat, Bill Erkelens; 2) **Sensible Shoes**, Corsair F-38cc, Toby Reichenberg. (2 boats)

CATALINA 30 — 1) **Goose**, M&L Kastrop; 2) **Dancing Bear**, Joe Askins; 3) **Star Kite**, Laurie Miller. (5 boats)

CORSAIR F-24 — 1) **Origami**, Ross Stein; 2) **Puppeteer**, Thom Davis; 3) **Ruverdance**, Pierre Chatelain. (6 boats)

OVERALL — 1) **Crazy Diamond**, 2) **Backatcha Bandit**, 3) **Yucca**, 4) **J-World**, 5) **Chilaxn**; 6) **Vuja De**; 7) **Bodacious**; 8) **Outsider**; 9) **Sand Dollar**; 10) **Axel Heyst**. (87 boats)

PETER LYONS / WWW.LYONSIMAGING.COM

Maxi Yacht Rolex Cup

'Feast or famine' would be a good way to describe the 2007 Maxi Yacht Rolex Cup held September 2-8 in Porto Cervo, Sardinia. The second day of racing was abandoned due to winds holding at 40



MARINA BAY YACHT HARBOR

A Certified Clean Marina

(510) 236-1013

www.MarinaBayYachtHarbor.com

1340 Marina Way South
Richmond, CA 94804



- Berth to Bay 15 Minutes
- Single Load Concrete Docks
- Deep Draft Harbor
- Nearby Boatyards, Marine Stores and Fuel Dock
- Wireless Internet
- Check Out Our Fall Specials

knots and gusting to 60. Though 38 of the biggest and best boats and crews from 11 countries were chomping at the bit to race, relief was felt upon the race committee's decision to abandon.

The following day, during the 65-mile coastal race, Bob Oatley's R/P 98 super-maxi *Wild Oats XI* was dismasted. Four crew members ended up in the drink but were soon recovered. One sustained moderate injuries. This has left the *Wild Oats* team scrambling to repair the boat in time to make the 2007 Rolex Sydney-Hobart race in December.

On day four, a windless famine set in, causing a two-hour delay. Racing finally got underway in breeze that stayed light and flukey throughout the day.

Boats in the five divisions ranged in size from 60 feet in the mini-maxis, to 145 feet. And designs spanned about 70 years, from elegant full-keel boats like the 128-ft J-Class yacht *Velsheda*, built in 1933, to cutting-edge canting keelers launched just within the last year or two.

West Coasters in attendance included Tom Whidden calling tactics for Arne



ROLEX / CARLO BORLENGHI

'Wild Oats XI' after the fall. Hopefully she'll be rerigged in time for Sydney-Hobart.

Glimcher's division-winning *Ghost*, and Morgan Larson, who likewise guided *Morning Glory* to the winner's circle.

After the race, Neville Crichton's team announced that the latest *Alfa Romeo*, a R/P 98, will be for sale after the European circuit ends this month. If you want to break into the big time maxi circuit and have an extra \$5.5 million burning a hole in your pocket, this could be your ticket to the big time.

RACING (IRC) — 1) **Morning Glory** (GER), MaxZ86, Hasso Plattner, 9 points; 2) **Loki** (AUS), R/P 60, Stephen Ainsworth, 9; 3) **Titan 12** (USA), R/P 75, Titan Racing Inc., 11. (7 boats)

MINI MAXI (IRC) — 1) **Allsmoke** (GBR), (n/a), Gunter Herz, 4 points; 2) **Edimetra VI** (ITA) Wally 65, Ernesto Gismondi, 12; 3) **Aegir** (GBR), (n/a), Brian Benjamin, 13. (11 boats)

MINI MAXI (IRC) — 1) **Atalanta II** (ITA), Farr 70, Carlo Puri Negri, 6 points; 2) **Allsmoke** (GBR), (n/a), Gunter Herz, 11; 3) **OPS 5** (ITA), Baltic 60, Massimo Violati, 14. (13 boats)

CRUISING (IRC) — 1) **Ranger** (CAY) J-Class, R.S.V. Ltd., 4 points; 2) **Velsheda** (USA), J-Class,

SLAM

ADVANCED TECHNOLOGY SPORTSWEAR

866-488-4060 WWW.SLAM-SHOPS.COM

THE RACING



ROLEX / CARLO BORLENGHI

Neville Crichton's very successful R/P 98 canting keeler 'Alfa Romeo' reportedly goes up for sale this month. If you have to ask . . .

Turbat Investment Ltd., 8; 3) **Ghost** (USA), Brenta 122, Arne Glimcher, 10. (9 boats)

WALLY (IMAX) — 1) **J One** (FRA), Wally 80, Jean Charles Decaux, 6 points; 2) **Indio** (ITA), Wally 80, Andrea Recordati, 8; 3) **Dark Shadow** (MON), Wally 100, Antexis Ltd., 14. (8 boats)

Complete results: www.yccsmaxi.com/

Race Notes

Testing, testing — the Pre-Olympic

Test Event (August 10-25) in **Qingdao** was a success and proved that China is ready for next year's Summer Olympics. Qingdao International YC is known for its support of *Team China* in the 32nd America's Cup, and the city hopes to help develop the sport of sailing throughout Asia. American sailor Anna Tunnicliffe placed first in the

Laser Radials showing much strength for the U.S. Olympic Team. Also slated to do well is the U.S. Paralympic Team. Qingdao's wind tends to come up in the morning, and it only gets humid and hot through the day, so racers are hoping for early-in-the-day starts.

Oh, we got trouble — The **2007 1D35 Nationals** on August 17-19 featured

good breeze, tight competition and even a collision (both boats were damaged and disqualified). Eight boats, all local, sailed eight races, with Andy Costello's *Double Trouble* once again topping all comers — although due credit goes to Mark Witty's *Alpha Puppy* and Gary Fanger's *Sweet Sensation* for giving the *Trouble-makers* a run for their money.

Farr better things — The Royal Danish YC hosted 36 boats from 13 countries in the **Rolex Farr 40 Worlds**, sailed from August 29 through September 1 on Oresund Strait between Denmark and Sweden. Although there was a strong Nordic representation, competitors came from as far away as Australia. Defending champion Vincenzo Onorato and his *Mascalzone Latino* team managed to pull off another win this year over some very tough competition, including Ernesto Bertarelli's *Alinghi* and '04 champion Jim Richardson's *Barking Mad*, which took second and third places respectively. This fleet is alive and well.

Mind over matter — Lake Ontario was the site of the **IFDS Disabled Sailing World Championships** on September

PERFECT LOCATION & GREAT INVESTMENT Own a Slip on San Francisco Bay

**EMERY COVE
YACHT HARBOR**

BUY A SLIP: Save money & earn equity! Save 1/3 of your rental cost. Enjoy big tax savings as a slip owner. Emery Cove Yacht Harbor is the only marina on the Bay with FEE SIMPLE dockminium ownership.

OR RENT A SLIP: 35-60' slips! Rates from \$8.00 to \$9.20.



CALL FOR A MARKETING PACKAGE • 510-428-0505
3300 Powell Street, Emeryville, CA 94608 • www.emerycove.com • Email: info@emerycove.com

7-15. Upwards of 170 sailors from all over the world participated in one of three classes: 2.4Ms (singlehanded), SKUD18s (doublehanded) and Sonars (three crew). Rochester YC hosted the five days of racing. The top winners from each class were: 2.4M — Damien Sequin (FRA); SKUD-18 — Karen Mitchell (USA); and Sonar — Rick Doerr (USA).

Waving the flag — San Rafael's **Liz Baylis**, sailing with Cory Sertl and Susy Leech, won the U.S. Women's Match Racing Championships last month. Eleven teams participated in the series, which was sailed out of Detroit's Bayview YC on September 5-9 in Ultimate 20s. Baylis, who also won this event in 2003, battled to the end with New Orleans sailor Katy Lovell. And we mean *the end* — in the final matchup, the two frontrunners were so close at the finish line that no one knew who won until Baylis' yellow flag was waved, signalling her win! 2006



Mike Campbell and Dale William's pretty Kernan 70 'Peligroso' rounds the West End of Catalina during the Long Point Race.

defending champion Debbie Capozzi of New York was third.

26 miles across the sea — Newport Harbor and Balboa YC's **Long Point Race** on August 25-27 is sooo Southern California — and we mean that in a good way. How could it be anything but good to race to Catalina on Thursday, up and down the face of the island on Friday, and back to Newport on Saturday — all in glorious SoCal sunshine and moderate breeze? As well as being a lot of fun for competitors, it's a kick for spectators aboard boats moored or at anchor at

White's and Isthmus Cove to watch the passing parade. Thirty-four boats from a B32 to two SC 70s took part.

Overall honors this year went to Don Haskell's famous 67-ft S&S yawl **Chubasco**, which had three bullets. It's hard to complain when a spectacular World World II-era yacht, which is maintained to world class standards, comes out on top. (And as we recall, it's not the first time *Chubasco* has won this event.) Second overall was naval architect Alan Andrew's Andrews 38 *Doubletime*, with the Kinslay/Redman 1D48 *Chayah* in third. But as we all know, the only losers in this event were those who didn't participate.

APS
"The Raceware Specialists"

KNOWLEDGE
 - Shop Where Fellow Racers Work

CONVENIENCE
 - Online Orders Save on Shipping
 - Same Day Shipping
 - Speedy Custom Rigging

SELECTION
 - Largest Selection of Racing Hardware,
 Apparel, & Cordage In the World...Online
 and In Stock!

www.APSLTD.com ~ 800.729.9767

We focus this month on **Sailing Options for Solo Travelers**, with an **Overview of Opportunities**, a special report on an **All-Female Sail Training Cruise**, and miscellaneous **Charter Notes**.

Travel Partners? Who Needs 'Em: A World of Opportunities Awaits

They say that timing is everything. It's true with swinging a baseball bat, investing in the next tech sensation, asking your boss for a raise, delivering the punchline of a joke, taking a relationship to the next level. . . just about every endeavor in life, including blocking out dates for travel.

When some folks find that their window of availability for vacationing — i.e. taking a sailing trip — doesn't jibe with their would-be travel partners, they simply bag their plans in frustration, sulk a bit and hope things will work out better next time. Others, however, say, "Screw it! I'm going without them."

And why not. If you know where to look, there are hundreds of exhilarating travel options designed for solo travelers, and a good number of them fall within the realm of sailing. Some are instructional, teaching you key skills which will prepare you for confident cruising. Others are focused on fun in the sun, where you're expected to do nothing more demanding than slather on sunblock and keep yourself hydrated. Some are offered close to home, while others will require that you travel halfway around the planet before you ever step aboard.

The first place to begin assessing your options might be our local S.F. Bay

When she's not chartering here on the Bay, the schooner 'Seaward' offers book-by-the-book voyages in Mexico.



LATITUDE / JR

sailing clubs (schools). Most of them put together bareboat flotilla charters in exotic locations around the world several times a year. And while such trips are marketed to club members, most will be happy to book outsiders too. You can generally elect to share a cabin or pay a 'single supplement' and have one all to yourself. Greece, Turkey, Tahiti, Tonga, the Grenadines and the British Virgin Islands are among the places that local clubs have visited in recent years. With licensed instructors along as group leaders, you can often complete ASA or US Sailing course certificates while en route. In the Northwest, San Juan Sailing offers popular Learn-N-Cruise weeks during the summer, which combine instruction with island hopping.

If none of the schools' dates work with your vacation window, check the websites of charter companies such as The Moorings, Sunsail and Albatross, which offer scheduled trips (booked by the berth) for sailing in the Caribbean, Med and Aegean.

In 'Downeast Maine' the sailing season is drawing to a close, but it will start

The 140-ft brigantine 'Soren Larsen' offers hands-on sail training while exploring landfalls of the South Pacific, such as Moorea.



SOREN LARSEN

up again in May, when a spectacular fleet of historic coastal schooners and replicas will offer week-long or half-week cruises through the Penobscot Bay region. What the open layouts of these vessels lack in privacy, they make up for with warm-hearted camaraderie — and a traditional lobster bake is always part of the itinerary. Participation is encouraged, but not required.

On the opposite coast, a traditional vessel dear to our hearts is the former S.F. pilot schooner *Zodiac*, which operates a full calendar of cruises in the Pacific Northwest from spring until fall.

Another fine schooner worthy of mention is one that's relatively new to the Bay Area charter fleet: During the winter months, the schooner *Seaward* offers a variety of trips in Mexico, plus the repositioning cruises down and back.

If you someday intend to take your own boat across oceans or around the world, consider tapping the vast practical knowledge of John and Amanda Swan Neal aboard their Hallberg-Rassy 46 *Mahina Tiare III*. Their ambitious schedule often takes them to less-traveled waters, such as Norway and Spitsbergen this summer!

Another expeditionary vessel which offers sail training along the way is featured in the accompanying article: the former Whitbread racer *Alaska Eagle*. Based in Newport Beach, she offers top-notch sail training cruises from the Antarctic to the South Pacific.

For those with a soft spot for tarred rigging, glistening varnish and time-honored sea chanties, consider a cruise aboard one of this writer's favorite ships, the square-rigged *Soren Larsen*. Based in New Zealand, she does annual circuits through the South Pacific islands offering 'voyage crew' of all ages an authentic education in marlinspike seamanship. The view from up on yardarms is truly spectacular.

In the age of Google, it's a snap to research all the trips mentioned here without ever leaving your desk. And we've really just scratched the surface. So if your workaholic sailing mates are too obb-

BARBARA MARETT

OF CHARTERING

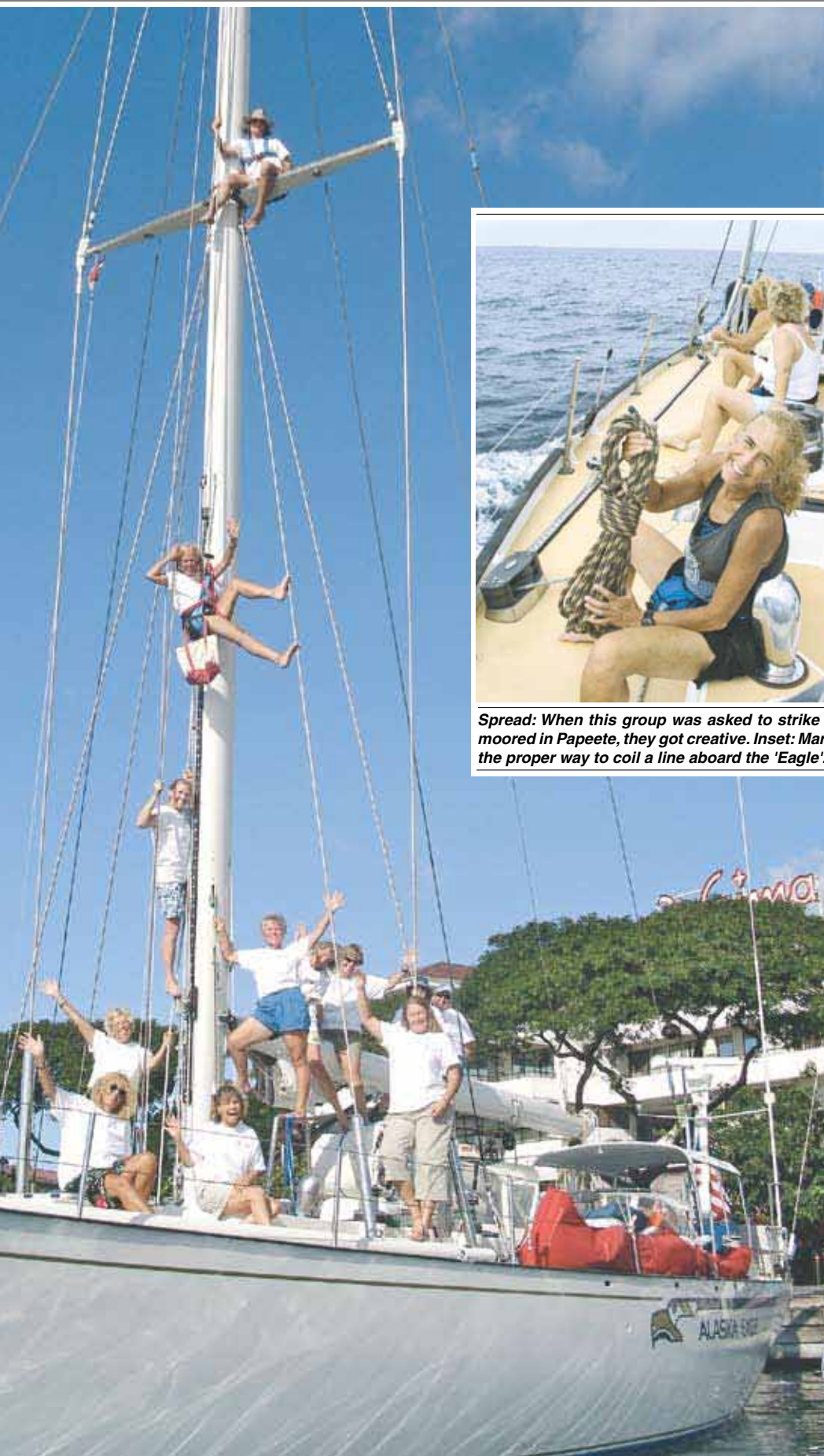

BARBARA MARRETT

Spread: When this group was asked to strike a pose while moored in Papeete, they got creative. **Inset:** Marley shows us the proper way to coil a line aboard the 'Eagle'.

essed to break away, or their timing just doesn't sync with yours, don't sit home and feel sorry for yourself. Get out there and have an adventure that will remind you that you're alive! We think you'll thank us if you do.

— *latitude/at*

Hawaii to Tahiti on the Wings of an Eagle

For every journey that ends, there is a story to be told. This tale chronicles the voyage of the S&S 65 *Alaska Eagle* from Hawaii to Tahiti, with stops at Fanning Island and Moorea.

On July 27, nine crewmembers (all female), Skipper Karen Prioleau and her staff Sheila McCurdy and Barbara Marrett, gathered for the first time in Hawaii. Following a group briefing and final preparations, we set sail at 0700 on July 28 for the 2,700-mile journey to Tahiti.

Throughout our passage, the crew shared a passion for the sea and sailing, a commitment to our communities, love for our families and support for each other. When our doubts and fears became larger than the courage we had to disarm them, our crewmates were there with unconditional support and kindness. Moment to moment opportunities allowed time for increasing sailing proficiencies in all aspects of seamanship. Equally, the passage allowed time for introspection and contemplation. Best of all, there was always a boatload of laughter, even when we were uncomfortable, tired, sick or soaking wet.

With success, we completed our passage on August 14 with our arrival in Papeete, French Polynesia. The passage was a milestone achievement for members of the crew. While we each traveled a different pathway in making our decision to sign on for the trip, the reason for undertaking the challenge became less important than the reality of being engaged in a lifetime dream. Our group of exceptionally competent, empowered and passionate-for-sailing women found the courage to say "yes" to the adventure and with that one decision, each opened a door to learning. With the opening came an explosion of growth both in respect to sailing competency and personal growth.



PANDORA NASH-KARNER

Placing twelve crew in a 65-ft boat for a 2,700-mile voyage will always present challenges. What was exciting in this passage was that with each challenge, the team responded with optimism, creativity and a can-do attitude. Challenges included: developing our relationship as

No wonder they call it paradise. The 'Alaska Eagle' approaches Cook's Bay, Moorea, one of the most famous anchorages on earth.

a team, learning the systems of the boat, aligning our behaviors with the standards of operations (SOPs) for the *Eagle*, adjusting sleep to our watch schedules,

and generally adapting ourselves to life at sea. Additionally, everyone was challenged with the physicality of managing the *Alaska Eagle*, motion sickness, the emotional adjustments of being away from family and friends and the fears that were held by each of us. As for the rewards, they were enumerable; all simple and all meaningful: sunsets, full moons, beautiful blue oceans, rainbows, dolphins, tropical breezes, an unending panorama of stars, great food, the southern cross, an equator crossing celebration (including a visit with King Neptune him/herself), hot showers, and most of all, freedom from the obligations of life ashore. All of these rewards were experienced in the company of emerging friendships.

The entire experience was professionally orchestrated through the expert leadership of Skipper Prioleau and her team who collectively embodied the qualities that inspire 'followership'. Technical and teaching competency were in great supply. Organization and intentional outcome goals were evident with each decision and activity. Patience

HAVE WE GOT A CAT FOR YOU...

GO CATS
Catamaran Charters Worldwide

In North America
Call for a Brochure
1.800.592.1254
WWW.GOCATS1.COM

SOUTH PACIFIC • MEDITERRANEAN • CARIBBEAN • INDIAN OCEAN

Tahiti,
is calling you

The...
magical seduction! spectacular beauty!
dazzling sunshine! turquoise lagoons!

Charter a new catamaran for a week or more
and cruise around the best palm trees in the world

TAHITI YACHT CHARTER CO.
P.O. Box 5162 • Newport Beach CA 92662
949-675-3519 • Fax: 949-723-8512
marimktg@ix.netcom.com

For reservations Call toll free:
1-800-404-1010
anywhere in USA or Canada

www.tahitiyachtcharter.com

OF CHARTERING



ALL PHOTOS PANDORA NASH-KARNER

and humor were integrated into teaching styles. Daily technical training sessions were offered. Challenges were addressed in a calm manner and, most critical for the crew, was that the Skipper and her staff created an on-board community in which everyone was included and

Changing sails, clearing lines and studying the charts were all part of a day's work on the 2,700-mile voyage to Tahiti.

everyone mattered, regardless of backgrounds and experience. The staff were consummate professionals who modeled a teacher/leader ethos.

In addition to the personal benefits that the crew captured through the voyage, we also had the opportunity to serve as ambassadors for our nation and for the Orange Coast College School of Sailing and Seamanship. Our travel to Fanning Island included the provision of

NORTH AMERICA • CARIBBEAN • MEDITERRANEAN • SOUTH PACIFIC • INDIAN OCEAN

OUR EXPERIENCE, MAKES
YOURS A BETTER ONE.



The Moorings has been providing "The Best Sailing Vacations In The World" since 1969. Our reputation for meticulously maintained yachts, unmatched customer service and the best selection of exotic destinations to choose from, guarantees an unforgettable, personalized sailing adventure. Plus, choose from the largest catamaran charter fleet in the world. So set sail and enjoy the vacation of a lifetime.

The Moorings®
The Best Sailing Vacations In The World!

www.moorings.com • 800-521-1198



BAREBOAT • CREWED • SKIPPED

WORLD

mutual aid through the delivery of school and medical supplies to the island community. We also provided assistance in coordinating support for the community's broken Ham radio and we collected and transmitted information about their medical supply needs. The experience underscored our personal responsibilities to our global community.

The *Alaska Eagle* program and the entire team at the sailing school are truly AAA rated! They provide an annual itinerary of ocean passage-making opportunities. For anyone who is interested in getting some sea miles under their belt and making a passage through a structured, reputable and safe program, consider the *Alaska Eagle*. To read the full log of our 2007 Leg 2 adventure or to get more details on the *Alaska Eagle* program, visit the weblink at: www.occsailing.com.

I'll close with a special note of appre-



HAJO OLI

Even the most hard-hearted among us would have to admit that these little guys are cute. Join a cruise and meet them face to face.

ciation for Skipper Prioleau and her staff, who provided our crew with the journey of a lifetime and an experience that will forever provide tales to be told!

— Jean Marie Scott

Jean Marie — Wow! What a glowing, heart-felt testimonial. So, what didn't

you like about the trip? Just kidding. Few sail training programs can rival the OCC's stellar reputation. We have a feeling you'll be back for another cruise before too long.

— Ed.

Charter Notes

In keeping with this month's theme — adventurous trips that can be booked by individuals — we'll bring you an update on the exceptional **barque Europa**. Regular readers will recall that we ran a report in June

on the ship by Bay Area sailor Jennifer Johnson — you remember, she's the one who broke her leg doing the limbo after crossing the notorious **Drake Passage** unscathed.

If her enthusiastic recommendation inspired your curiosity, we're happy to inform you that the globetrotting ship, built in 1911, is now taking bookings for their **2008/2009 season** (yes, a year from now). **Four 22-day expeditions to**

The Right Equipment.
The Lowest Cost.

Visit us at
the Annapolis
Boat Show
October 4-8,
2007.

Price Guarantee
BEAT ANY OFFER BY \$100!
888-788-0549
www.footloosecharters.com

Footloose
SAILING CHARTERS

Monohulls and Catamarans 33' to 50'

BRITISH VIRGIN ISLANDS
ST. VINCENT AND THE GRENADINES
NEW ZEALAND • TONGA

Antarctica are scheduled between mid-November and mid-February. Each will include several landings, if possible, at such places as the Shetland Islands and Deception Island, both renowned for their **animal and bird life**. "Further South we sail through enormous ice masses and an Adelie penguin colony will be visited," writes Reinoud van der Heijden from the company's Rotterdam, Netherlands home office. "In previous seasons, we were often visited by curious **humpback whales, minky whales and even curious orcas or killer whales**, swimming alongside the ship."

Trips begin and end at Ushuaia, Argentina. The ship sails with a professional crew of 14 and 48 voyage crewmembers of all ages and nationalities. Accommodations are in four- or two-person cabins.

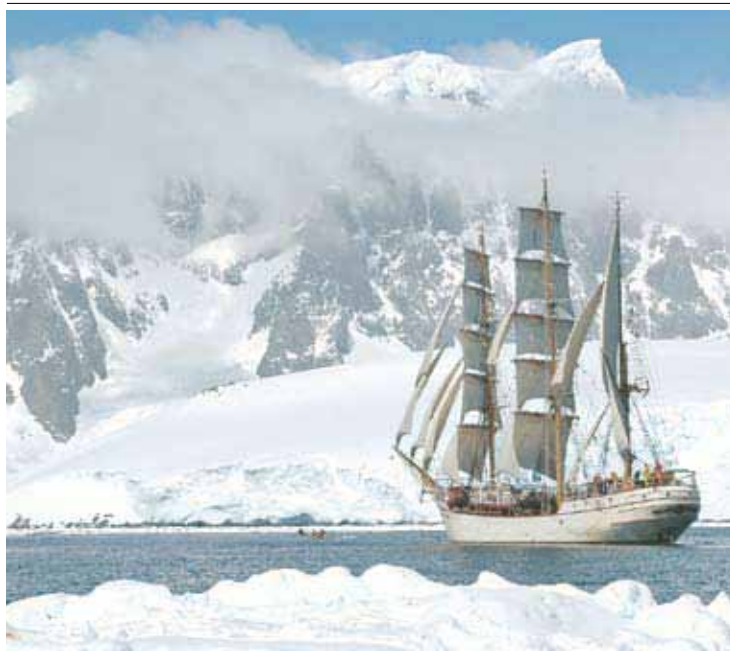

HAJO OIJU

Needless to say, the 'Europa' really does sail whenever possible. And wow! Do they ever get to some amazing places.

The season's fifth expedition is a seven-week voyage from Ushuaia via Antarctica, to **South Georgia and**

Tristan da Cunha to Cape Town. Now *that's* what we call a sailing adventure!

For full details and more about the ship's history, see www.barkeuropa.com.

Half a world away, in the bath-water-warm waters of **Belize**, former Bay Area sailors **Cliff and Sherry Wilson** would like to invite *Latitude* readers to consider sailing aboard their luxury charter cat **Aubisque**.

Before relocating to their new tropical home, Cliff and Sherry both did a great deal of racing on everything from 505s to 70-ft maxis. Cliff was an owner/driver in several TransPacs, and Sherry's bio explains that she is proud to have been the first female maxi skipper.

This does not mean they will be racing through the shallows of Belize, past all the great dive spots and cozy anchorages if you decide to charter the three-cabin

PACIFIC OFFSHORE PASSAGES AND PRIVATE CHARTERS

57' Steel Cutter. Custom Built 2002 in BC, Canada.



- PRIVATE CHARTERS: Mexico * BC Canada * Offshore * \$5,000 - \$11,000/week
- San Francisco to Cabo San Lucas: Oct. 13 - Nov. 8, \$2400 - \$4100/person
- San Francisco to Ensenada: Oct. 13-21, \$1750 - \$2800/person
- Ensenada to Cabo San Lucas: Oct. 22 - Nov. 8, \$2000 - \$3100/person + 10% tax
- La Paz to Puerto Vallarta, many stops: Dec. 3-15, \$1600 - \$3400/person + 10% tax
- Puerto Vallarta to Zihuatanejo: Jan. 14-29, \$2400 - \$4100/person + 10% tax
- Mexico to Hawaii: March 31 - April 22, \$2400 - \$4100/person
- Hawaii to Victoria, BC: April 28 - May 21, \$2400 - \$4100/person
- Around Vancouver Island: June 7-21 & Sept. 6-20, \$2600-\$4200/person

Sailing Yacht Western Grace
www.WesternGrace.ca
 808.271.3540

ORCA YACHT CHARTERS

(800) 664-6049 (206) 774-9879 info@orcasailing.com

CREWED YACHTS WORLDWIDE

Sail & Power
Entry level to Megayachts

View 1,000 + Yachts Online
www.OrcaSailing.com



CARIBBEAN • MEXICO • PACIFIC NW • MEDITERRANEAN • ALASKA
 GREECE • SOUTH AMERICA • GALAPAGOS • ASIA • BAHAMAS
 CROATIA • SOUTH PACIFIC • INDIAN OCEAN • TURKEY

And more!
 Sorry, no bareboats.



WORLD OF CHARTERING

Lagoon 47 cat. No, these days they've traded in their racing gloves for straw hats, in keeping with the pace of their newly-adopted home.

After sailing with the Wilson's, Alameda sailmaker **Norm Davant** wrote this review: "As a professional sailor and sail loft owner, I have to say that my charter experience aboard *Aubisque* was incredible. As part of the yachting community, I have known Sherry

and Cliff for over 20 years. I have great respect for their yachting expertise as well as their personal qualities.

We had an incredible week of trade wind sailing, trolling for dinner, diving and snorkeling along the reef, and island hopping. **Belize is truly a water wonderland to discover.** The Hol Chan experience is not to be missed! As for cuisine, you will enjoy the ultimate in gourmet

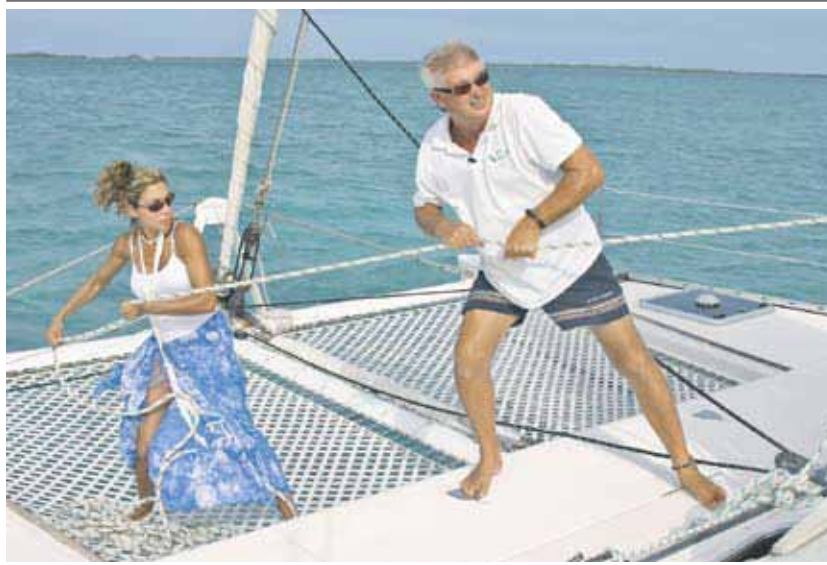

AUBISQUE

Raising the main on the Lagoon 47 'Aubisque' before yet another day of splendid sailing through Belizian waters.

Caribbean dining aboard *Aubisque*. We had such a great time that I was inspired to make a new asymmetrical spinnaker as a gift to the boat.

Needless to say, we will be coming back shortly to test it out ourselves. Cliff and Sherry run a **first-class char-**

ter operation. Their local knowledge and their genuine hospitality made our experience very special."

For more info, see <http://www.catchartersbelize.com>; email crwslw@aol.com or call 011-501-608-5300.

Our final note this month is that although winter is approaching, that's no reason to forget about sailing. If it's too darned cold here at home, consider a trip to any of the great winter destinations. In addition to Belize, there are, of course, all the islands of the Eastern Caribbean, plus the Sea of Cortez, Thailand, New Zealand and Australia.

Whichever spot sounds good to you, we suggest — as always — that you book early so you won't be left with the last boat in the fleet. And if you're thinking about doing a charter over the holidays, you'd better book it yesterday!

We are now accepting 2008 reservations!

Reserve early for the best choice of yachts and dates!



ANACORTES YACHT CHARTERS

PACIFIC NORTHWEST ADVENTURES

Largest Selection of Charter Yachts in the Pacific NW
Bareboat & Skippered • Power and Sail
Yachting & ASA Sailing Schools
Charter Yacht Ownership

www.ayc.com
800.233.3004

YACHT CHARTERS IN GREECE, TURKEY, ITALY & CARIBBEAN

Best Rates For Reliable Charters
Full services: Low airfares, hotels, tours, transfers

Visit our website for yacht photos and details, destinations and itineraries:
www.albatrosscharters.com

PLAN WINTER CARIBBEAN CHARTERS NOW!

Sailboats • 30'-60'
Bareboat/Crewed
Monohulls & Catamarans
Luxury Sail & Motor
5 to 60 Guests

Albatross
An American owned and operated company

(800) 377-8877
(856) 778-5656
Box 250, Moorestown, NJ 08057

Maine Cat 30 & 41 Hope Town, Abaco, Bahamas Bareboat Charters

Enjoy well protected Sea of Abaco waters with their beautiful islands and beaches aboard an open bridgedeck cruising catamaran. A breeze to handle and fully equipped.



www.mecat.com or www.maineatcharters.com
New email: info@mecat.com Phone: 1-888-832-CATS

Closest full-service charter base to Desolation Sound & Princess Louisa Inlet
Visit our Web site for a preview of our 25' to 54' Power & Sail fleet

One week bareboat charters starting at U.S. \$800

e-mail charter@desolationsoundyachtcharters.com
<http://www.desolationsoundyachtcharters.com>

#101-1819 Beaufort Ave., Comox, B.C., Canada V9M 1R9
TOLL FREE 1-877-647-5815 FAX (250) 339-2217

**Marine Diesel Specialists
AT YOUR SLIP!**



30 years experience • Universal/Westerbeke dealers
Repairs/Tune-ups all models • Engine Surveys, Instruction

BAY MARINE DIESEL 510-435-8870

baymarinediesel@comcast.net

Latitude 38

**MEXICO-ONLY CREW LIST
& BAJA HA-HA PARTY**

**ENCINAL YACHT CLUB, Alameda
Wednesday, October 3, 6-9pm**

**FREE for 2007 Baja Ha-Ha Skippers & First Mates only
Everyone else pays \$7 at the door** (exact change very helpful)

Apertivos • Name Tags • Guest Experts • Door Prizes • No Host Bar

www.latitude38.com • (415) 383-8200

Tortola BVI
Belize
The Grenadines

**UNIQUELY
TMM**

Marisa
TMM Belize

Most charter companies offer blue water & palm trees, but it takes the personalized care of people like Marisa to make your vacation a success.

Like Marisa, everyone at TMM is committed to your complete satisfaction. Our specialized three-location operation offers large company quality with small company service. A combination that is uniquely TMM.



catamarans • monohulls
motor yachts
ownership programs

**BRITISH VIRGIN ISLANDS
"BEST DEALS ON KEELS"**



Conch
Charters

Est. 1986

- Most selection of sailboats 32'-52'
- "Purr" with cats 37'-45'
- Bare boat or skippered
- Best yacht management program

**NEW
YACHTS IN
FLEET!**

www.conchcharters.com

Email: sailing@conchcharters.com

Call our 'Sails' Office

(USA) (800) 521-8939

Tel (284) 494-4868 • Fax (284) 494-5793

Sail paradise with Conch Charters

CALIFORNIA'S CARIBBEAN CONNECTION

Real People. Real Sailing. Real Fun.

Sail Cats | Power Cats
Monohulls | Trawlers
Bareboat | Skippered

Real Choices.

Choose CYOA and become part of the family. We've been providing beautifully maintained yachts, personal service and sensible prices to sailors since 1980.

1-800-944-2962
info@cyoacharters.com
www.cyoacharters.com
St. Thomas USVI 00802

**CYOA
YACHT CHARTERS**

CHANGES

With reports this month from **Nereida** on having sailed all the way across the Pacific to Indonesia; from **Finisterre** on three years of cruising between Mexico and Ecuador; from **Tanasza Polska** on a young woman's 3,400-mile solo passage to Vanuatu; from **Far Niente** on Palmerston Island; from the new marina at La Cruz; from **Coco Kai** on adventures in Central America; and many **Cruise Notes**.

Nereida — Najad 361
Jeanne Socrates
Landfall At Bali, Indonesia
(England)

I'm presently having a lovely sail within sight of the rugged mountains of Pulau Sambawa — I believe 'pulau' means 'island' — on my way to the island of Bali, having left Darwin on September 1. I expect to reach Bali Marina early on the 8th, but I'm almost certain to have to slow down so as not to arrive before it gets light.

After a frustrating first couple of days of almost nonstop motoring on calm seas, I've had a mix of excellent sailing — albeit mostly on a dead run. As a result, I've had to frequently jibe the main and poled-out genoa. But the wind strength has varied greatly, so I've had to motor in the occasional calms, too. It certainly hasn't been a boring passage.

Going back a bit, I arrived in Cairns, Australia, from Vanuatu on July 11th, which completed my crossing from Zihuatanejo — a really big Puddle Jump. I got a lovely welcome in Cairns, including from my cousin, whom I hadn't seen in several years. Having not been to Australia before, it was nice to arrive by sail. From Cairns, I made my way inside the Great Barrier Reef, daysailing north to Cape York, where I nearly lost my steering. It turned out that the cable to the quadrant was totally frayed. I caught it just in time to make an emergency repair that lasted me one week and 820 miles to Darwin. Speaking of Darwin, now there's a place with an impressive tidal range!

Jeanne, a Singlehanded TransPac vet — has now sailed all the way across the Pacific on her way around the world.

At one point near the Vernon Islands in the Howard Channel, I was motoring really hard at 7.9 knots, but only making 2.4 knots over the bottom! It's a good thing that *Nereida* has a strong and well-looked-after engine!

After a short stop in Bali to enjoy a bit of Indonesian culture and ambience — boat jobs permitting, of course — I'll be on my way across the Indian Ocean, making for South Africa. I hope to be in Richards Bay by mid-November. That would involve several long passages, however, so I hope the weather gods will smile down on me. And I'm keeping my fingers crossed, partly for the final leg from Reunion Island across the Agulhas Current to South Africa, and partly for the long leg from Cocos-Keeling to Rodriguez. When my friend Jim Kellam did that latter passage two years ago, he had 30-knot winds for over a week. Mmmm, I'd better check my trysail and storm staysail before I leave Bali.

— *jeanne* 09/15/07

Finisterre — Santionge 44
Mike & Kay Heath
Five Years After Our First Ha-Ha
(Eureka)

What have we been up to since Mike did the '00 Ha-Ha as crew aboard Rick Gio's Sebastapol-based *Freya 39 Gypsy Warrior*? In '04, after we both ditched our work careers and finished preparing *Finisterre*, we did the Ha-Ha on our own boat. Since then, we've travelled to Ecuador by way of Mexico, Guatemala, El Salvador, Honduras, Nicaragua, Costa Rica and Panama.

To a certain extent, we could be considered 'commuter cruisers', as for the last three years we've been on the move during the November through April dry seasons. During the summers we've come to visit with family and friends. In order to do that, we've left *Finisterre* at Marina Nuevo Vallarta near Puerto Vallarta, Mexico; at King & Bartlet Marina in Golfito, Costa Rica; and most recently on the hard at the Puerto Lucia YC in Ecuador. Our plans for the upcoming season include travels in South America and sailing to the Galapagos. After that, who knows?

We may be somewhat different



from most cruisers in that we view *Finisterre* as a means not only to explore the Pacific coastline, but also as a vehicle to move from one country to the next to learn more about the culture of each. In addition to cruising from anchorage to anchorage, we've made the conscious decision to travel inland at every opportunity. We found many opportunities for inland travel in Mexico, and also recommend traveling in Guatemala — even though we didn't even stop there with our boat. The city of Antigua, Lake Atitlan, and Copan Ruinas, just inside Honduras, offer colorful delights of pre-colonial history and insights on current indigenous life.

When it comes to anchorages, we liked those near Loreto in the Sea of Cortez, and especially San Juanico. We also liked most of the anchorages south of Banderas Bay on mainland Mexico. Working down the coast of Central America east of Guatemala, there aren't many anchorages until you reach Costa Rica. We loved being up the estuary at Bahia del Sol,





Jurgen and Judy's Norseman 447 'Anna'. The Heaths and their buddyboaters went far into the Darien, where few cruisers tread.

El Salvador — once we were across the bar! But with a boat that draws seven feet, we wouldn't cross that bar again. Travelling further ESE along the Central American coast in the direction of Costa Rica, we also liked Puesta del Sol Marina in Nicaragua.

Once we got to Costa Rica, we really enjoyed the Bahia Santa Elena anchorage because it was so protected, the hiking was great in the Santa Elena Forest Preserve where Ollie North once did some of his clandestine activities during the Contra days, and because we found a chambered nautilus on the beach. We also loved Ballena Bay, Costa Rica, which had the first lush jungle — howler monkeys included — after so many dry tropical forests.

While in Panama, we liked the anchorages in the western islands, the Perlas Islands in the Gulf of Panama, and the Darien Province in southern Panama.

But the anchorages in western Panama were the best. Bahia Honda, for example, is a lovely, well-protected anchorage with delightful people. They'd often come to visit, loved to trade, and remembered us when we returned. Panama's islands are often sparsely inhabited, so we enjoyed many spots without anybody around — not even other cruisers or fishermen. When the local fishermen did come by, they often brought freshly caught lobster and fish. In the Bay of Panama, we enjoyed many anchorages in the Las Perlas Islands, catching glimpses of participants in the Turkish production of *Survivor* at Contadora Island. When we got to Isla San Jose, we met Dieter and Gerta, two real survivors, who regaled us with tales, and sold us enough grapefruit for our trip to Ecuador that there was no way we'd get scurvy. But they also — fair enough — expected the obligatory bottle of rum.

Our favorite inland trip was across Nicaragua by water — al-

though not aboard *Finisterre*. We took a ferry from Granada to Ometepe Island on Lago de Nicaragua, then continued on to San Carlos at the head of the San Juan River. We then rode water taxis all the way down the river to the Caribbean port of San Juan del Norte de Nicaragua. What a delight! There were rapids, dug-
San Juanico, Baja, has been one of Mike and Kay's favorite anchorages between San Francisco and Ecuador. It's easy to see why.



CHANGES

out canoes plying the river currents, a great jungle walk, and the old Spanish fort at El Castillo. It was the adventure of



The 'goose-eggs' in the latitude position mean that 'Finisterre' had crossed the equator on her way to Ecuador.

a lifetime! Puesta del Sol Marina was the safe haven for *Finisterre* while we made that trip inland.

Another highlight was cruising in the Darien Province of southern Panama, which we did in March of this year. Many cruisers avoid the Darien, which is a vast collection of rivers and estuaries located along Panama's border with Columbia, because it's true wilderness. Indeed, the only other boat we saw was Jurgen and Judy's *Anna III* — and we buddyboated with them up the Sabana River to the Wounaan village of Boca de Lara. We enjoyed meeting the indigenous people, and the Wounaan were very friendly and helpful. The women make a wide variety of lovely baskets using all natural fibers and dyes. The town of La Palma is a crossroads — or more properly, a cross-rivers — of trade. The roads are short but the rivers are long, and most goods arrive and depart by boat. La Palma is a bustling one-street town where you can buy fresh fruits, Hamm's beer, and meet a great mix of people. The gateway to the Darien rivers, La Palma is actually a good place to provision. Then you can actually *Kay*, holding a bottle of bubbly, celebrates her and Mike's crossing the equator while on their way to Ecuador.

take your sailboat miles up the major rivers to lovely, quiet anchorages populated by river woodsmen, fishermen, ibis, and parrots. We found that you can have as much quiet and solitude in those anchorages as you can atop mountains in the Sierras.

A member of the Punta de Mita Yacht & Surf Club, Mike enjoyed surfing at various spots around Banderas Bay and south to Ecuador. Many of the better surf spots in Central America were surprisingly crowded, so the lesser spots were often more enjoyable just for the pleasure of getting your own waves. He liked the breaks at Puesta del Sol in Nicaragua, Isla Catalina in Panama, where the reef break can be gnarly for an old guy, an unnamed spot in the Las Perlas Islands, and his favorite spot of all, the point off the Farallon Dillon in Ecuador. The owners of the Farallon Dillon, whom we befriended while working on *Finisterre* on the hard at the Puerto Lucia YC, graciously allowed us to leave our boards there. After an early morning bike ride or a hard day's work in the yard, Mike often had the surf all to himself. He had one ride that was so perfect and so long that he couldn't help but yell and scream at the end — only to realize that nobody had been around to see it. It will be interesting to see what surf awaits him upon our return to Ecuador at the end of September.

Speaking of returning to Ecuador, it will also be interesting to see what the latest situation is there with regard to port entry fees, new fuel prices for cruisers, and how long cruising boats will be allowed to stay. We'll give an update as soon as we can.

Good luck to everyone in this year's Ha-Ha. Mexico's friendly people, delicious food, and happy music have been among the highlights of our trip. Work on your Spanish while there, because, once south of Mexico, you'll need it.

Despite the greater language barrier, the people will still be outgoing, and, while you won't be able to count on getting the delicious *tipico* Mexican food, you'll still be able to find chicken, beans, rice, tomatoes and cucumbers. No matter where you cruise, we encourage you to travel inland to see the fine old Spanish cities, the beautiful handicrafts, the quiet central squares and to enjoy conversation with local people. They will try their English, you try your Spanish, and



you'll make bonds of friendship across borders.

— mike & kay 08/20/07

Tanasza Polska — S&S 34 Natasza Caban First Leg, Solo Circumnavigation (N/A)

When I departed Honolulu on the start of my proposed 22-month solo circumnavigation, I knew the 3,400-mile first leg to Vanuatu would present me with a steep learning curve. But I didn't know that I would be so challenged on the very first night! As the sun set, my mainsheet block broke, and a second later the pin that attaches my autopilot to the steering system came undone. So as the boom jibed over my head, I was forced to steer while trying to set my windvane. How wonderful it would have been had my headlamp worked, or if I had had a chance to go below to fetch my flashlight, spare blocks and some straps.

By the following morning, I'd learned to be careful when wishing for calmer conditions. I was becalmed. It gave me a chance to make repairs, of course, but

MIKE HEATH

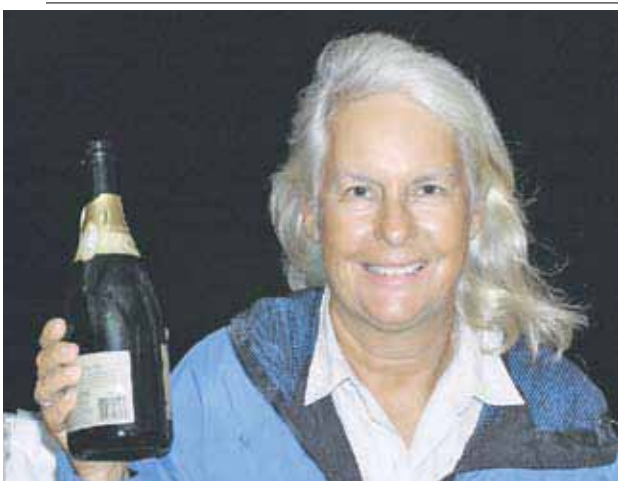

IN LATITUDES

COURTESY TANASZA POLSKA



Natasza braves the sea snakes for a swim at Port Vila, Vanuatu, after her 3,400-mile first leg. She'd left Hawaii on June 28.

when the repairs were completed I still had no wind. I'd brought fuel along, but only enough to motor through the doldrums, so for two days my boat was a 'painted ship on a painted ocean'. I began to wonder if this was how my dream was going to play out.

Nonetheless, I was happy to finally be out on the ocean starting my big adventure — although the first days were hard mentally. Having not made a long solo passage before, I began to have doubts whether I would be able to make it all the way around. I knew that I needed to learn more about my boat, become familiar with her telltale noises, and learn to sail her efficiently. In addition, my body had to become accustomed to the demands of being at sea, and, as a singlehander, to having to get up every 20 minutes to look around for ships. I discussed these matters with the pilot whales that came alongside my boat. They sang back, and it relieved me to learn that they didn't think I was insane for talking to myself.

I had birds almost all the way to Vanuatu, and always wondered which islands they came from. A couple of times I sailed through large schools of fish — some of them large fish. I caught one fish that finally got loose because I just wasn't strong enough to land it. Another time I caught a fish that I initially felt was too small to keep. I dragged her behind the boat while I tried to figure out a way to avoid killing her. I sat outside in the cockpit to keep her from feeling so lonely. Eventually, I decided that I should eat her for ceviche. But by that time, I found that a larger fish had already taken the little fish and my hook. As in the rest of life, timing is everything.

One night about half-way through my first leg, I got a weird feeling in my stomach. Call it intuition that something bad was going to happen that night. I always set my alarm in order to keep a good watch, but when I get really tired, I sleep through it. Somehow I woke myself up, went outside, and there it was — a

fishing boat on a collision course with me! Just as I was about to tack away, a huge squall came through. Did I mention that I had a problem with my roller furling headsail? It wouldn't furl. I ended up with rain pouring into my eyes, the boat heeled over so far my boom was dragging in the water, and getting much too close to the fishing boat. Finally they saw me and changed course. I wished them a good evening, but asked that they keep a better watch.

A short time later, I saw a nighttime rainbow for the first time ever. It was awesome and made me smile again. Even though my furler wasn't working, three battens were poking holes in my new main, my engine sometimes wouldn't start, and water had leaked all over my books, the rainbow made all those things seem like part of my dream. It made me smile.

I gave up many things to be able to do this trip, and have worked very hard. Nonetheless, I realize that I'm lucky to have the opportunity, and that dreams can come true. But I wouldn't be here were it not for the help of many other people and companies. When things get tough and I get a little down, thinking of all of them cheers me up and makes me stronger.

I've already made it to Efate Island, Port Vila, Vanuatu. It's funny, because I actually yelled "Land ho!" even though I was by myself. Only the dolphins and birds could hear. The people of this nation are among the friendliest I've ever met, and have been taking great care of me. I've gotten a berth, a bed and a bath, horserides on the beach, and much more.

It's hard to leave such a wonderful island and such friendly people behind, ***The lives of some can be limited by their looks. Natasza, based on her sailing ambitions, isn't having that problem.***



TANASZA POLSKA

CHANGES

but I must continue on, as the rest of the world is waiting. Having finished repairs to my furler and gotten the main back from the sailmaker, I'm about to take off. While swimming next to my boat I saw a sea snake, and it scared me. But I'm told there will be big sharks, nasty jellyfish, and crocodiles waiting for me in the Torres Strait, so how could I let a little snake scare me?

I plan to stop at Cocos-Keeling in the Indian Ocean next. It should take me about 45 days.

— nat 09/15/07

Far Niente — Island Packet 42 Eric & Gisela Gosch Palmerston Island (Hemet)

When we arrived at Palmerston Atoll, located in the southern Cook Islands, we learned that it's somewhat unique for two reasons. First, it's only accessible from the outside world by boat. Even more exceptional is the fact that the island's 67 inhabitants are all descended from one man, William Marsters, who laid his claim to the atoll in 1863. With three concurrent wives, he fathered 26 children and created his own island dynasty. Marsters' descendants now number around 8,000, and live all over the Cook Islands and New Zealand. At one time, the atoll's population was as high as 150, but has dropped steadily as the young people have moved away for greater opportunities.

Marsters divided the atoll's 30 small *motus* equally among his three families, but established leeward Palmerston Island, just 3.2 square miles, as the home base for everyone. Careful rules were established for the allocation of resources and land for each family, and strict guidelines were set for marriages between the families. Two lines of twin

Eric and Gisela at one of their many stops in the South Pacific. The couple took a long break between their Ha-Ha and Puddle Jump.



MIKE ANDERSON

coconut trees cross the island to delineate property lines, separating houses of each of the three principal family lines by as little as 10 feet.

Palmerston Atoll receives about \$160,000 U.S. each year in support from the Cook Islands government, and that money is allocated according to the decision of the Palmerston Island Council, comprised of equal appointed representation from each of the three families. All island decisions must have unanimous approval of the Council. Lately the council has been divided as to whether to allow an airstrip to be built on an outlying *motu*.

The other principal source of island revenue is fishing. As a freighter comes to the island only three or four times a year, Palmerston has the highest ratio of freezers — crammed full of fish — to people in the world. Electricity is provided by a large generator, which is only run every other six hours in order to conserve fuel. There is one solar-powered telephone — in a glass telephone booth, no less! When the phone rings, the kids race to answer it. Callers are told to call back 10 minutes later, during which time the intended recipient is located and hustled to the booth. The phone works via a satellite dish, which means the island has internet access.

The one-room schoolhouse serves 24 children, aged 6 to 16, who work through educational packages independently and at their own pace. Palmerston is the only Cook Island where English is the native language, although it has become blended with a Gloucestershire burr and Maori vocabulary. But children are required to adhere to textbook English while in school.

As can be imagined, visiting yachties are a welcome break from family politics and conflict — and are a transportation source for greatly needed supplies. The atoll has a long-standing tradition that

the first person to greet an arriving yacht will welcome the crew into his home and make sure they are introduced to the island. Still honoring the custom established by William Marsters almost 150 years ago, visitors are never charged anything for staying on the island, whether for two nights or two months. In return, however, visitors are expected to help out and offer their services where needed.

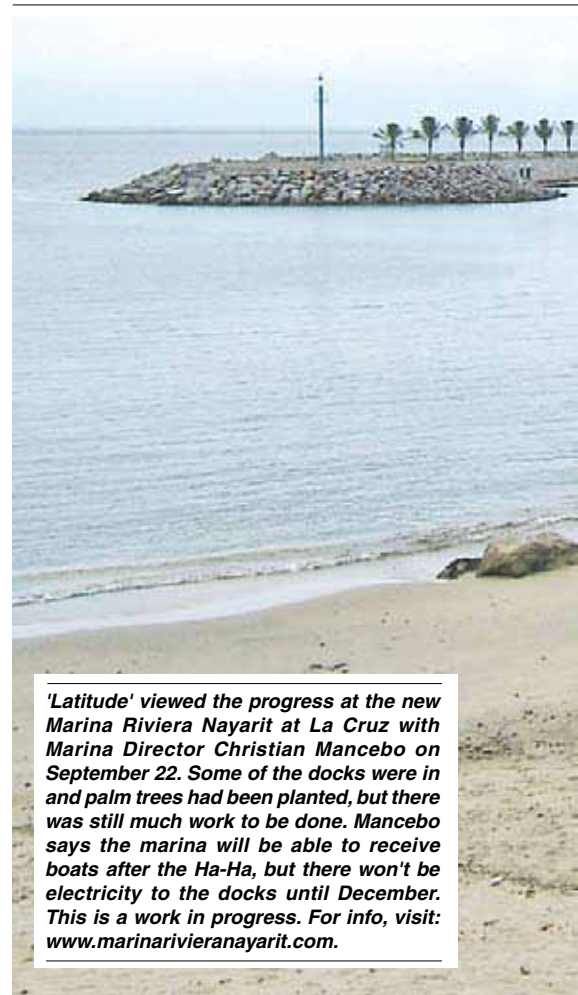

'Latitude' viewed the progress at the new Marina Riviera Nayarit at La Cruz with Marina Director Christian Mancebo on September 22. Some of the docks were in and palm trees had been planted, but there was still much work to be done. Mancebo says the marina will be able to receive boats after the Ha-Ha, but there won't be electricity to the docks until December. This is a work in progress. For info, visit: www.marinarivieranayarit.com.

Because of the system, family members are trained to spot approaching boats when they are still far out at sea. Then they scramble to be the first to contact the vessel by radio, guide them to one of the five moorings — another source of income — and host them ashore for the duration of their stay. Between 50 and 70 yachts call on Palmerston during the May through October cruising season.

Most cruisers come to Palmerston after visiting Rarotonga, where the harbormaster's staff loads the boats up with goods for one of the three families on Palmerston. We, for example, were given boxes of nappies (diapers), fortified baby formula, and corned beef for Bill Marsters. While later at Atitutaki, we were contacted by a customs official on the VHF to pick up bananas for Bill's family.

Upon approaching Palmerston, we heard various radio transmissions before realizing that somebody was trying to contact us. We finally responded to Bob Marsters' call, and spotted him in his aluminum skiff as we approached the atoll. As there is no passage into the lagoon for

IN LATITUDES



ARD

most boats, you have to anchor outside the lagoon at the edge of the reef in an open roadstead that's only safe during easterly winds. Unfortunately, all the moorings were taken on the afternoon we arrived, so we had to anchor. Bob directed us to the exact spot where we needed to drop our hook. Once our hook was down, Bob as well as Taia, 16, and Goldine, 14, two of his daughters, and Andrew, 8, his son, pulled alongside and introduced themselves. Bob told us he'd come around the next morning to give us an island tour and host us for lunch.

The next day we loaded the goods for Bill's family into Bob's skiff, and wound our way through the shallow reef to Palmerston Island. Tipu, Bob's wife, had prepared a sumptuous spread of parrotfish, taro, rice and coleslaw for three of the visiting yachts. One yacht was a 100-ft adventure sailing yacht, where the 40 paying guests serve as part of the crew, so Tipu had made lunch for over 50 people! After lunch I joined several of the women in a line to, assemblyline style, wash the dishes.

We later met Bill Marsters and his wife

Mits, who were very appreciative of the items we'd brought for them. Mits told me that she was down to the final bottle of baby formula for her six-month-old Sydney, so we'd brought the formula just in time. She also asked Bob for permission to host us for lunch the next day as a way of thanking us. We sensed a bit of jostling between the families of Bill and Bob as to who was our official host. We later learned that Bob is mayor and Bill does not own any of the moorings in the anchorage. In response, Bill built the Palmerston Island YC, which is a covered patio and loft and where yachties can use his two washing machines for free. Bob and Bill seem to disagree on many things, including the need for an airport. Bill thinks an airport will introduce commercialism and excessive tourism, thus changing the essence of the Palmerstonian lifestyle and its historical focus on yachties. Bob, on the other hand, lost a son because of inadequate access to emergency healthcare and views the air strip as a basic necessity. It's easy to appreciate both points of view.

On Sunday morning we joined Bill's family for church, and were the obvious focal point of attention for those pres-

ent. Once again we are enchanted by the singing, in both English and Maori, and were stunned to later learn that most islanders have no idea what they are singing in Maori. Meanwhile Mits had outdone herself for lunch: chicken, lamb, tropicbird — a delicacy with grayish meat that has a very wild and fishy taste — as well as rice, taro, spinach with corned beef, coleslaw and sponge cake. There were many leftovers, and we were encouraged to pack them up and take them back to our boat. This from people who have very little to begin with. To decline would have been to offend them, so we picked out a few items, leaving the tropicbird — which none of us cared for — behind. We spent the rest of the day visiting with the townfolks, as any work or play — including that by children — is forbidden on the Sabbath.

In appreciation for their hospitality, we brought t-shirts and DVDs for both Bill and Bob's families, and brought inflatable world globes, pencils, and markers to the school teacher. Bob took us around the island to distribute our stash of reading glasses to both young and old. Bob also asked to borrow three additional DVDs to watch that evening. As there is no live television on the island, DVDs are their only window to the outside world. DVDs are what stimulate a hunger for life beyond the small family island, and are the impetus for most high school-age kids to leave for New Zealand and other islands.

Our third and last day in Palmerston was spent helping Bob install an additional mooring to replace one lost during a cyclone two years ago. We provided some extra chain and shackles we had onboard, and Bob had the mooring floats and lines. Eric and I dove to wrap the chain through large coral fissures — and

You can sometimes meet the nicest people who are crossing the Pacific — on a Honda. Or whatever bike the Gosches are on.



MIKE ANDERSON

CHANGES

discovered an incredibly beautiful coral reef, as well as more than 100 feet of visibility, beyond the drop-off. A skittish white-tip reef shark checked us out from a safe distance as colorful parrotfish swam by. We took our time at our task in order to soak up the beauty around us. A few hours after we completed the job, a catamaran pulled into the anchorage and tied up to the new mooring. We'd just helped provide a way for Bob to supplement his income!

After an afternoon of volleyball on the beach with members of all three families — both young and old are skilled — and good-byes to everyone, we weighed anchor around sunset — only to find our chain stuck in the coral. I eagerly volunteered for another dive to unfoul it, leaving Eric at the helm. Despite the pending darkness, the visibility was still very good at 95 feet — yikes! — and in short order the chain was free. During my final glimpse around, a beautiful spotted eagle ray glided by, giving a fitting conclusion to an incredible island experience and the entire Cook Islands.

— eric /8/15/07

**Coco Kai — 65-Ft Schooner
Jennifer Sanders, Greg King
Central America
(Long Beach)**

Time flies when you're having fun, and we — my eight-year old daughter Coco, my boyfriend Greg, and I, really had a great time in late spring and early summer cruising from Puerto Angel, Mexico, to Golfito, Costa Rica. After a summer back in Southern California, Greg has headed back to the boat to get her ready for the upcoming season, while

Coco, on the left, didn't meet as many cruising kids as she hoped she would, but the ones she did meet became good friends.

Coco and I are eager to follow in a few weeks.

The state of Oaxaca in southern Mexico is lovely, and there are six fine coves to explore in the Huatulco area, which is why we stayed there for several weeks. Bahia Chachacual is a particularly beautiful cove that is relatively isolated. We had it all to ourselves — except for the few hours every couple of days when a tour boat stopped by with snorkelers.

Coco and I enjoyed snorkeling there with Ducky, our 10-year-old black lab, as it had the clearest water we've seen in Mexico, with more than 50-ft visibility on good days. And there were tons of sting-rays and tropical fish. One day the water was so clear and blue that a bait ball in the shallows near the beach looked like a tornado moving to and fro. Ducky managed to get in the middle of it, and when the hundreds of small fish bumped into her legs, she jumped straight up in the air! Coco and I howled. But Ducky is a good swimmer who always went with us when we snorkeled, and sometimes swam as much as a quarter of a mile from the boat to shore.

We left the schooner in the marina at sizzling Huatulco for a week and headed inland in a rental car. Our destination was Oaxaca, a lovely colonial town with some great ruins at 5,000 feet above sea level. The road had a many switchbacks — yikes! — although Coco and Greg thought careening around turn after turn, with sheer drop-offs, was exhilarating. We spent the night in a rented cabin, complete with a fireplace, in the mountains. After the heat of coastal Mexico, it was refreshing to get cold enough to want to start a fire.

Buildings in colonial cities such as Oaxaca have just walls and gates fronting the streets. Once you're inside the gate, there are beautiful courtyards and gardens. We stayed at the Hotel Mariposa — Spanish for butterfly — which had a great courtyard with fountains, turtles and fish, and even a resident bunny that ran around eating the leaves that fell from the trees. We visited the Zapatec



COCO KAI

ruins at Monte Alban, as well as the huge — multiple city blocks — market in Oaxaca. Then we headed back down to the coast via a different route, one that took us past the ruins at Mitla, the limestone 'water' falls, and several of Mexico's more famous weaving towns. Coco and I tried *chapulines*, the local delicacy, but Greg was too chicken to sample the spiced grasshoppers. They tasted 'interesting', not like chicken.

Once back in Huatulco, we got a good weather window, so we high-tailed it across the Gulf of Tehauntepec to El Salvador. Our three-day crossing was pleasant, and left us at Bahia de Jiquilaco, one of only two good spots to stop in El Salvador. Nonetheless, we still had to cross the bar that is surrounded by breaking waves in order to reach the estuary to get to the marina. It's not clear where the 'break' in the line of breakers is, so the marina sends a *panga* down to guide you in. All of Greg's years of surfing paid off, as he drove *Coco Kai* down a couple of big waves, and we were in! We then followed the *panga* five miles up the estuary to lovely Marina Barillas.

Marina Barillas is actually a private beach club that has about 10 moor-



Spread; 'Coco Kai' looks great with all her sails flying. Inset; Jennifer, who owns the schooner, holds up the good kind of 'bug'.

ings. They cater to wealthy locals — the ex-President of El Salvador stopped by one day — and visiting cruisers. For \$12/day, we had access to the beach club facilities, which included a nice pool, lovely grounds, and a restaurant. They even provided a guide to walk us to a spot in the jungle where a troop of about 30 spider monkeys live. We had so much fun feeding them bananas that we did it twice.

There's no problem with officials at Barillas. We'd barely gotten secured to our mooring when English-speaking Herberto arrived in a *pinga* with officials from Customs, Immigration and other offices, who were there to welcome us to El Salvador. Talk about turning the often painful checking-in process into a pleasant experience! Herberto runs the marina, and is a great source of information for cruisers. For example, as Greg dealt with the Immigration officials — which is a 'blue' — or guy's — job in these macho countries — I asked Herberto if we could swim off the boat. The water was the typical brown of estuaries,

but didn't look polluted. Herberto said he couldn't recommend it, then paused to point out a crocodile that just happened to be swimming by! Several times later that week we saw the same croc on the nearby bank sunning himself, his mouth wide open.

There are a lot of guns in public in El Salvador. The gated marina was patrolled by armed guards who also checked the estuary area. The free mini-van shuttle that took us on the hour ride into the town of Usulután twice a week for provisions also came equipped with an armed guard. The supermarket in town had about 12 armed guards, and it wasn't unusual to see someone walking down the street with a rifle. We almost felt as though we were in Texas. Despite the guns, we felt safe, and didn't hear stories of people getting shot. Our theory is that there were so many unemployed men with guns after the long civil war that it just made sense to give them jobs as guards.

We hired a mini-van with a driver and guide to explore the interior of El Salvador, and visited a coffee plantation and two different ruins. One of the ruins was similar to Pompeii, as the ash from one of the nearby

volcanos buried the village intact about 600 AD. It was so well preserved that we could see the irrigation ditches in the garden by the small houses. These are the only ruins in Central America that had once had 'saunas'. We also saw cashew trees, and now know why they are so expensive. The fruit is the size of a pear, and there is just one little nut growing out of the top. The outdoor markets were interesting, and Coco especially liked the live purple crabs in the baskets, each one with a string attached. But they are pets, not dinner entres. Greg still hasn't found what he's looking for — the perfect machete.

After a few weeks, the two drawbacks of El Salvador got the better of us. It was so warm at that time of year that touching fingers became a substitute for hugs. And let's face it, estuary is a nice word for swamp, so the bugs abounded. The nightly thunderstorms did provide some interesting entertainment for Coco, who, being raised in Southern California, hadn't experienced them before.

On our way to Nicaragua, we stopped in the Gulf of Fonseca, parts of which are claimed by El Salvador, Honduras and Nicaragua. Thanks to the offshoots of a tropical storm in Mexico, we had heavy rain and thunderstorms. Our next stop was the Puesta del Sol Marina in Nicaragua, which was built and is operated by Roberto Membrano, a longtime cruiser from San Diego. It would have been impossible to navigate the twisty entry through the breakers and around rocky patches in the estuary were it not for the

Unlike Natasza of 'Tanaska Polska', Greg King doesn't get emotional about fish. He just likes to catch 'em and eat the good ones.

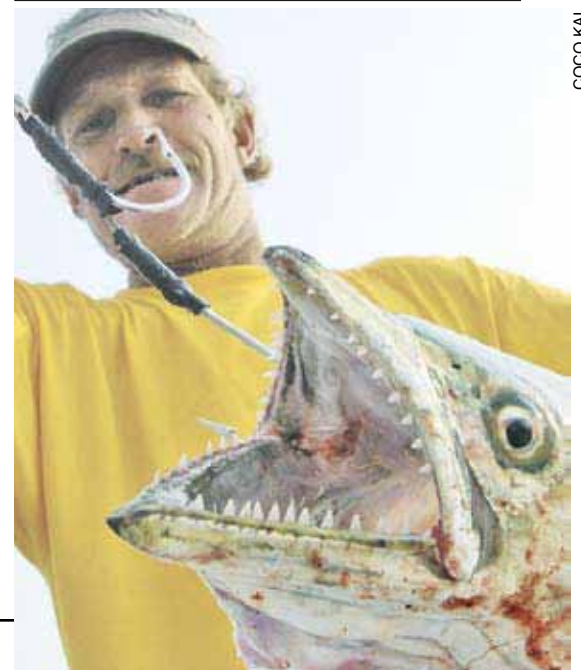

CHANGES

navigation aids installed and maintained by the marina. The 10-acre compound is also home to a hotel and has a lovely beach. Puesta del Sol is popular with tourists because it's got an excellent surf break. In fact, Greg abused himself with the amount of surfing he did.

Because there are so few options when it comes to anchorages and marinas along the coast of southern Mexico and Central America, you keep running into the same boats. As such, you become good friends and have a lot of potlucks. During one of these events Coco and I even learned to make pita bread. Having worked hard at a stressful downtown career for so many years, I can assure you that it was great to be able to take the time to make our own bread.

Once again we used the hotel shuttle to go to the nearest town, which turned out to be Chinandego, about an hour's ride away on dirt roads. Nicaragua is the poorest country in Central America, and you could tell by the lack of electricity and running water in the huts that people lived in. Most of these homes had a bicycle wheel contraption used to pump water up from a well. Pigs and other farm animals ran amok. Several times our van had to stop to allow a herd of oxen and goats, or horses, to pass by us.

City life, such as it is in Chinandego, turned out to be very different from city life in El Salvador. The town had the same colonial feel, but although the money-changers who hung out on the street corners had really big wads of cash, there wasn't a gun in sight. How refreshing. I also got a kick out of the ubiquitous public phone booths. They looked like your basic lemonade stand and were 'manned' by bored young women.

On our first such trip into town we *Jennifer luxuriates in the cockpit of 'Coco Kai', delighted to not be stuck in traffic on the way to her old job, high up in an L.A. skyscraper.*



were part of a group of 12 cruisers. Someone had read about a "great" Chinese restaurant, so we were all excited to have lunch there. We weren't even dissuaded by the fact it had no electricity or other customers when we arrived. After ordering, we learned they didn't have any running water either. But the food *was* delicious! The restaurant had the added bonus of a caged garden area in the interior that featured a tank with turtles, a good-sized pet croc, parrots, and other animals. The pet crocodile was so still against the side of the tank that he almost looked stuffed. Jeremy, one of the 'big kids', couldn't resist touching its tail to see what it felt like. His curiosity resulted in him having to get 10 stitches in a local emergency room.

The emergency room was interesting. It didn't take long for Jeremy to be treated, but before he could, Megan, his wife, had to go to the pharmacy to buy the medical supplies — sutures, needles and so forth. Only then could they stitch him up. The total cost, supplies included, came to \$23. About what you'd pay in the States, right? Jeremy was a good sport about the mishap, and we laughed as we composed a headline for *Latitude*: **Cruiser Attacked By Crocodile in Nicaragua!**

Roberto Membrano, the owner of Puesto del Sol, knows the owner of the famous Cana de Flor rum distillery, which makes 4, 7, 12, and even 19-year-old rums. As a result, we got a private tour. It was interesting to note that nothing is wasted. They even bottle the CO2 from the fermentation process to use in Coke and beer. The company sells their raw alcohol to Europe — as such, Bailey's Irish Cream is full of Nicaraguan rum. The family that owns the distillery had the foresight to move their assets offshore before the Sandinistas took over, so their \$2 billion family fortune remains intact. The Sandinistas liked their rum, so they never bombed or disrupted the rum production. But, we're told, they helped themselves to the rum. The current patriarch of the company, a third-generation graduate of Stanford, is no dummy, so he decided to start aging the rum three years instead of bottling it quickly. So once the Sandinistas were out of



power, the saved/aged rum was ready for market. We might have enjoyed our rum tasting a little more if it hadn't been at 10 a.m., but it was a good visit. We ended up buying several half-gallon bottles of the seven-year stuff in town for about \$10. It was quite the deal.

We reached Costa Rica by the first of June, escorted by a large pod of dolphins. After spending six weeks in estuaries, it was wonderful to be anchored in the Pacific once again, where we could jump off the boat when it got hot. We also hiked up a creek through the jungle to some lovely deep pools for inland swimming. Butterflies, parrots, macaws, bat rays and all kinds of other animal life abound, and we had far too many fun adventures to recount here.

We left *Coco Kai* on a mooring at Land & Sea Marina in Golfito for the summer, paying \$6 a day — including for them to look after Ducky. They charge \$4/day for people to use the dinghy dock, but have television and video, and a bar that operates on the honor system. Costa Rica is known for petty theft, so you never want to leave anything on deck, but we're told

IN LATITUDES



BOTH PHOTOS COURTESY HIDDEN PORT YC

Spread; Although 'Henriette' was a weak hurricane — if there is such a thing — 'Erikazona' was sunk. Inset; And, 'La Petite' was holed.

there is no violent crime.

We've heard that clearing into Ecuador and moving around has become more expensive and complicated, but it still doesn't sound too bad to us. That's our goal for the upcoming season. Good luck to everyone on this year's Ha-Ha, we had a great time last year.

—jennifer 07/15/07

Cruise Notes:

"August, September and October are the hurricane months in the Sea of Cortez," writes the editor of the Puerto Escondido, Baja-based Hidden Port YC website, "so everyone follows the weather reports of Don on **Summer Passage**. We first heard about then-tropical storm *Henriette* in early September when she was 200 miles south of Cabo, but that was close enough for us to be concerned that she might develop into a hurricane and come our way. Until then, it had been a relatively quiet summer in our part of the Sea, with water temperatures cooler

than normal. *Henriette* made landfall between Cabo San Lucas and San Jose del Cabo as a Category 1 hurricane, then traveled across land before heading into the Sea again around Cabo Pulmo, which is southeast of La Paz. Then she came north to us in Puerto Escondido before continuing on to Guaymas on the mainland side. We got hit starting at about 2:30 a.m.. *Henriette* was a relatively weak hurricane and didn't have as much rain as they expected. Nonetheless, the wind blew 75 knots, mostly out of the northwest, creating havoc. The following boats sank in the main harbor: **Le Petite, Backstreets** and **Boardroom**. **Erikazona** dragged her mooring and ended up half-submerged at the launch ramp. **Defin Solo** broke her mooring, but her crew was able to get their anchor down, and it held through the storm. The trisaran **Moon Me**, which had been Med-tied in the Eclipse area, suffered damage to one hull. In the Waiting Room,

Rumline snapped her mooring line, but, thanks to hitting the starboard side of **Last Mango**, was prevented from going into the rocks. The trimaran **Western Sea** went into the mangroves, but she's now back on her mooring with little damage. The dinghy dock ended up in three pieces."

We don't have exact figures, but believe that, once again, most of the seriously damaged boats were unattended. Note that there was a crew aboard *Delfin Solo*, and they were able to get an anchor set after their mooring broke. For additional photos of the damage — as well as lots of delicious-looking photos of the anchorages around Puerto Escondido, Google 'Hidden Port Yacht Club'.

As mentioned, *Henriette* came through Cabo and La Paz first. Norma Flores at **Marina Cabo San Lucas** reports that it only blew hard for a few hours, and didn't cause much damage. Patrick and Eileen Gerety of the La Quinta-based Willard 40 PH trawler **Aloha** report they were in Marina Costa Baja in La Paz, along with fellow Ha-Ha'ers such as **Ketch 22**, "when the eye passed directly over our condo." They report that it was an exciting few hours, but there was minimal damage. "Best wishes to everyone in the Ha-Ha," they write, "wish we could do it again."

Because of all the concerns about **climate change**, we've heard some alarmist "first time ever" claims about hurricanes in Mexico and Central America. It's true that on September 4 powerful Category 4 hurricane **Felix** slammed into the Caribbean coast of Guatemala on the same day that mild Category 1 hurricane *Henriette* hit Cabo. While that was the first time in recorded hurricane history that such cyclonic storms made landfall in the Caribbean and Pacific on the same day, people who made a big deal out of **Because the inner harbor at La Paz's Costa Baja Marina is around a corner from the open sea, it offers excellent protection from hurricanes.**

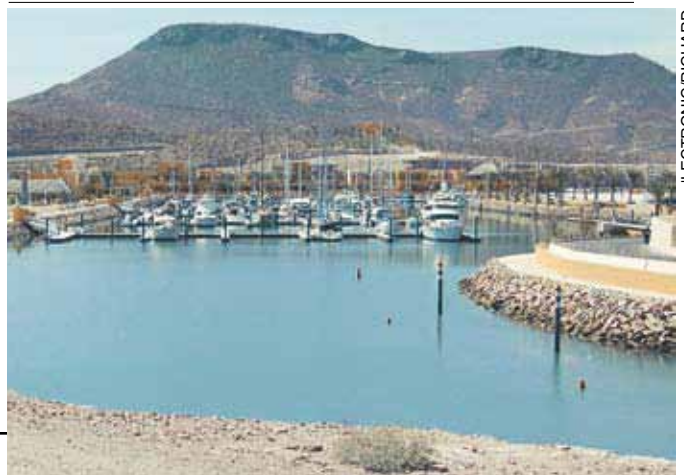

LELECTRONIC/RICHARD

CHANGES

that fact seem to have overestimated the significance. For one thing, the Pacific and Caribbean coasts of Mexico/Central America are in two different hurricane zones. Second, so far this season — it's not over until the end of October — it's actually been a relatively light year in both the Pacific and Caribbean. For example, by the middle of September there had been seven tropical storms and three hurricanes on the Pacific Coast of Mexico. But in that same time period last year, there had been five tropical storms and nine hurricanes, an astonishing six of the latter being Category 3 or higher. What's more, in the last seven years — which is as far back as we bothered to check — only '03 had seen as little hurricane activity to date as this year. Don't get us wrong, hurricanes and the possibility of hurricanes are never to be taken lightly. On the other hand, be careful that you don't get bamboozled by people who manipulate the facts. Want to become knowledgeable about the frequency, strength and paths of hurricanes in the Pacific and the Atlantic/Caribbean? It's easy. Just Google in



LELECTRONIC/RICHARD

The heck with hurricanes, what everybody wants in the Sea of Cortez — Isla Partida seen here — is blue skies and blue water.

'hurricanes + unisys', and you'll see the records for the last 50 years in fascinating and easy-to-digest graphic form. As for everyone with a boat in a hurricane zone — and that would include us

with **'ti Profligate** in the Virgin Islands — here's to hoping that the Pacific and Atlantic/Caribbean hurricane seasons end in boring fashion.

"Damn!" writes Bob Smith of the Victoria, B.C.-based 44-ft custom catamaran **Pantera**, "I'm up here in Victoria while my cat just got run over by *Henriette* at Marina Seca near Guaymas. To make me even more glum, I'm reading about all the lucky boats entered in the Ha-Ha. Now for the good news! *Pantera* has been on the hard since May, and I just learned from a friend at the marina that she did just fine sitting on his trailer, which usually holds his Cross 36 trimaran **Tambaran**. And the damage I suffered to my ankle and legs during last year's anchoring mishap in La Paz is healing well. I plan to meet the Ha-Ha fleet in Cabo. In fact, I'm feeling so good that I might even try to sail up to Bahia Santa Maria — or maybe even Turtle Bay — to join the Ha-Ha fleet. How many pesos if I do a one-third or two-third Ha-Ha?"

The last two legs of any Ha-Ha are always free to veterans of previous Ha-

Toll Free
1 866 365 25 62
01152 646 155 41 06

info@marinapuertosalina.com



New Slips Available 30 to 60 ft.
\$.55cts daily \$11.55 monthly \$9.35 & \$8.50 long term per ft per month.

*Marina
Puerto Salina*

Marina Services
Power 220 / 110 volts
Fresh water
Security 24 hrs
Cleaning
Dock master
Showers
Dressing room
Laundry
Immigration

Shuttle to :
Ensenada & US border
Pump out
Restaurant & Bar
Yacht Club
Dry Dock
14 ft depth at low tide
(channel access)

Lat. N 32° 3.28"
Long. W 116° 53.20"
Ensenada 27 NM south
Tijuana 39 NM North

Ha's, so we hope to see *Pantera* somewhere down the line. And by the way, Bob, we hope you'll read the notice about the **Banderas Bay Blast** a little further down in this section, as we're certain you'll want to be part of that.

Anybody from the '03 Ha-Ha remember Frank and Janice Balmer, the retired schoolteachers from Tacoma aboard the Gulfstar 50 **Freewind**? In the last four years they've covered 18,000 miles, and just recently left Thailand for Langkawi, Malaysia. "The one thing we've learned is that things are not as they seem they'll be in the dreaming/planning stage, nor as described in most of the cruising guides." That's pretty cryptic, so we can't wait for their upcoming report explaining themselves.

"Check out the photo we took of the Mexican Navy *panga* that caught fire while work was being done on her outboards," write Dennis and Susan Ross, vets of the '02 Ha-Ha aboard the Portland-based Endeavour 43 **Two Can Play**. "Interestingly, they didn't have fire extinguishers aboard, so they had to run

up to the API/fer-y building to get some. They finally got the fire out, but it looks as though the *panga* will be out of service for awhile. As we write this, we're at the new Singlar Marina at Santa Rosalia, Baja, waiting for hurricane *Henriette* to decide where she will come ashore on the Baja. Santa Rosalia is not our choice of hurricane holes, but as a result of losing our transmission last week, it's where we're going to have to stay. We had a new transmission installed, but don't think we should test it making a dash for shelter at Puerto Escondido or Puerto Don Juan. The marina staff, and especially Carlos, the Operations Manager,



The unfortunate truth is that once a fiberglass boat catches fire, she's all but impossible to put out before burning to the waterline.

have been very supportive and helped get everything in order. The marina is nearly full, so we will have lots of company."

To the best of our knowledge, Santa Rosalia had no hurricane damage.

It's been a long time coming, but Scott and Cindy Stolnitz of the Marina del Rey-based Switch 51 catamaran **Beach House** report they are about to



OWL HARBOR MARINA THE FRIENDLY MARINA

**HOME OF
ANDREAS COVE
YACHT CLUB
Limited Time Only—
\$100 Memberships
Call for details**

- 30'-50' deep draft berths @\$5.00 per foot
- Dry and open storage
- Extra wide berths for multihulls
- Home of Club Rio Sailing School
- Robert A. Viel, Certified Marine Surveyor

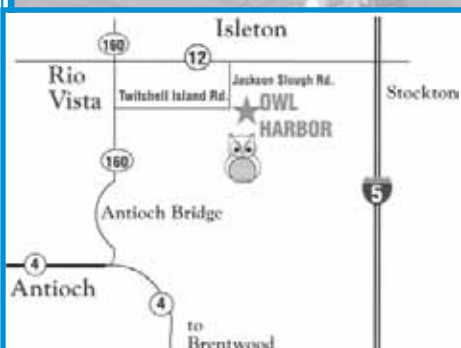

'CANVAS BY THE LOOP' On-site canvas & repair shop

- SAIL – Alterations & Repair
- CANVAS – New & Repairs
- SAILBOAT RIGGING
- HARDWARE INSTALLATIONS
- 12-VOLT REPAIR & INSTALLATION
- FAST TURNAROUND ON REPAIRS

LOCATED ON SEVEN MILE SLOUGH
OFF THE SAN JOAQUIN RIVER

HARBORMASTER: SHAWN PASSERI

(916) 777-6055

email: shawn@owlharbor.com
www.owlharbormarina.com

1550 W. TWICHELL ISLAND RD.
ISLETON, CA 95641

CHANGES

begin their cruise. They'll start slowly by heading up to Ventura in October for a bottom job and other maintenance, then continue on to the Channel Islands, Newport and Ensenada for the rest of their shakedown cruise. "Starting about mid-December," they write, "we'll head down the coast to Mexico, Guatemala, El Salvador, Honduras, Nicaragua, Costa Rica, Panama, and then west to the Galapagos. Our plan is to go where many boats have gone before, and avoid dangerous areas and weather conditions."

"With the mechanics and riggers finishing up their work, I'll be able to leave Sydney on September 8," reports Mike Harker of the Manhattan Beach-based Hunter Mariner 49 **Wanderlust 3**. Readers may recall that Harker, who got started in sailing during the '00 Ha-Ha, is about halfway through what he's hoping will be an 11-month circumnavigation. "I've added four new pieces of equipment to make my sailing safer and faster for the second half of my trip: 1) A new style of spinnaker called a Parasailor from the German sailmaker ISTEAC; 2) A Raymarine AIS, which is a ship proximity warning device; 3) A forward-looking



COURTESY WANDERLUST 3

The Parasailor spinnakers, with the cut-out in the center, sure look different. Some European sailors swear by them.

sonar from Interphase to try to help me stop hitting rocks and reefs; and, 4) A new diesel fuel filter system. Getting poor quality fuel at both Jamaica and the Marquesas Islands resulted in my Yan-

mar fuel injector pump being ruined. I now have the Fuel-Boss dual diesel filter cleaning system for the main tank, and the Filter Boss fuel filter and polishing system for my fuel transfer pump."

The Parasailor spinnaker is the invention of a top-flight German sailor who is also a paraglider. The concept is to shift the center of pressure on the sail to reduce rolls, yaws and pitches. In addition, thanks to a variable opening 'hole' in the middle of the spinnaker, it's supposedly capable of being carried in stronger winds. We've yet to see any of these sails in the United States, but 14 or so entries in last year's Atlantic Rally for Cruisers carried them.

Speaking of the **Atlantic Rally for Cruisers** (ARC) — the 2,700-mile event that leaves the Canary Islands in late November and arrives in St. Lucia in mid-December — just 10 of the 225 entries are Americans. Only one of them, James Eaton's Belvedere-based Hallberg-Rassy 43 **Blue Heron**, is from the West Coast. The appreciation of the euro versus the dollar is no doubt a big reason for the decrease in U.S. entries in recent years.



Marina Vista Coral

La Paz, Baja California Sur
Mexico

vista
CORAL
marina estates

*Anchoring & Mooring Services
in the Sea of Cortez*

Dinghy Dock • Competitive Rates • Best Location (downtown)
Beautiful View • Restrooms & Hot Showers
Three Restaurants on Premises – Breakfast, Lunch & Dinner
Beauty parlor in the Mall • 24-Hour Security

Call us **011 52(612)125-4212**

E-mail: vistacoral@prodigy.net.mx



in Southern California...



*A First Class Full Service Facility Serving the Entire Pacific Coast
150 Ton & 30 Ton Travelifts*

VENTURA HARBOR BOATYARD

Open 6 Days a Week!

Competitive Rates ~ Professional Staff

*For quality and attention to detail you can count
on our commitment to your satisfaction.*

(805) 654-1433

1415 Spinnaker Drive, Ventura, CA 93001
www.vhby.com

The fact that the Canadian 'loonie' has reached par with the dollar would also explain why that little country has seven entries in the ARC.

"Ten years ago this month, I sailed **Knot Yet**, my Gulf 32 pilothouse sloop, beneath the Golden Gate and headed to San Diego to join the Baja Ha-Ha," writes John Keen of Campbell. "Thus began 10 years of voyaging that ended in Malta this year with the sale of **Knot Yet II**, a Nordhavn 46 long-distance motoryacht that I'd purchased in Thailand in '01. The Ha-Ha was a great experience, and taught me the value of joining rallies. First, they get you ready to leave by a certain date no matter whether your endless list of 'to-do's has been completed or not. You just get the important stuff done and leave! Second, the camaraderie that develops by having shared experiences with so many wonderful people is fantastic. Third, plans and arrangements made by the organizers ease the planning tasks, although one is always responsible for one's own navigation and safety. Other rallies I participated in with *Knot Yet* were the Musket Cove-Port Vila Race from Fiji

to Vanuatu in '99; the Gove Over-The-Top Rally in Australia in '01, and the Darwin to Bali Race, also in '01. **Knot Yet II** joined the Singapore-Equator Rally in '01; the Eastern Mediterranean Yacht Rally in '04; and the 62-day Black Sea Yacht Rally in '04. The top three rallies were the Baja Ha-Ha, the Eastern Med Rally, and the Black Sea Rally. I sailed 15,400 miles on *Knot Yet*, and voyaged 14,500 miles more on *Knot Yet II*. While I had intended to circumnavigate, last year I decided that I just wasn't enjoying it that much anymore, and that the additional 1,000 hours at sea it would take me to complete my circumnavigation in Acapulco was more than I wanted to do. Another factor is that I'm 10 years older than when I started. I continue to



Beach games for kids at Turtle Bay in the Ha-Ha. There's no easier way to make lots of cruising friends than on a rally.

read *Lectronic Latitude* in my house in Thailand as well as when I'm home in California, and I could sense the Grand Poobah's excitement when, on August 13th, he wrote: "Now is the sweetest time of the year for sailing in California, but the Ha-Ha almost makes us wish that fall would hurry up and arrive." Thanks again for the continued inspiration of *Latitude* and the 'get-started experience

Puerto Lucia, the gate to the South Pacific

www.puertolucia.com.ec

2800 miles to Marquesas Island

Galapagos At only 500 miles from Puerto Lucia

Excellent climate year round, floating docks, fuel, laundry, Mediterranean-style moorings, Wi-Fi, Cruiser's Lounge electric and water hook-ups.

South Pacific Ocean

50-ton Travelift
Long and short term dry storage . Maintenance and provisioning.

Ecuador has the Best Climate in the World
(Source: International Living, January 2005)

For Further information: 593-4-2783190 / 593-4-2206154 or email us: marina@puertolucia.com.ec, www.puertolucia.com.ec

CHANGES

of the Ha-Ha. Oh yeah, I almost forgot the obligatory mention of the number of countries I visited and my favorites. I visited 33 countries and my favorites were Fiji in the South Pacific, Thailand in Southeast Asia, and Turkey — followed closely by Croatia — in the Med."

Thanks for the very kind words. And yes, we're really excited about the upcoming Ha-Ha and season in Mexico. Part of it is because we're joining with others to start a new sailing event in the Puerto Vallarta area, the December 7, 8 and 9 **Banderas Bay Blast**. The Blast is several events in one. On the surface, it's a match race challenge between John Haste's Perry 52 catamaran **Little Wing** for the Vallarta YC, and **Profligate** for the Punta Mita Yacht & Surf Club, to get a little cruisers's racing rivalry going between the two clubs on the bay. But everyone else with a boat is encouraged to participate, too, and however little or much as they want. The Blast will start with a Friday cruisers reaching race from Paradise Marina to the La Cruz anchorage and marina, with a blowout at ex-cruiser Philo's that night. Saturday

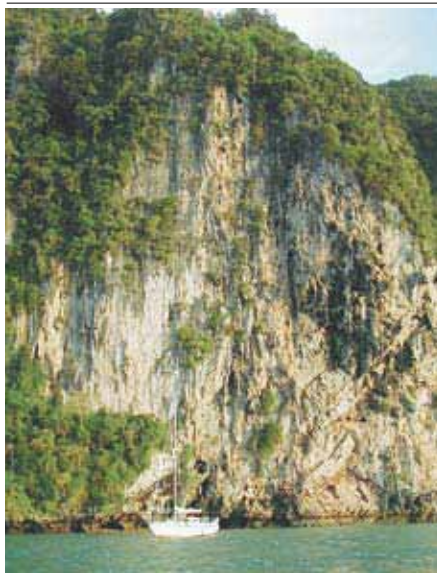

JOHN KEEN

Keen did 15,000 miles with the Gulf 32 pilot-house 'Knot Yet'. She's seen here in Thailand, one of the 33 countries he visited.

will be another fun cruiser's race from La Cruz to Punta Mita, with the grand reopening that evening of the Punta Mita Yacht & Surf Club, Commodore Eugenie Russell presiding. Sunday will be the

Pirates for Pupils Spinnaker Run for Charity from Punta Mita back to Nuevo Vallarta, where Lupe and J.R. of the Cantana 47 **Moon & Stars** are inviting everyone for a post-Blast party at their *casita* on the lagoon in Nuevo Vallarta. Other 'dark-siders' who have announced their intention to participate are Wayne and Carol Baggerly of the Brisbane-based custom 45 **Capricorn Cat**, Dave Crowe and his Vallarta-based M&M 70 **Humu-Humu**, Mai Dolce and her Belvedere-based Marquesas 56 **Dolce Vita**, and several others. While there will be a number of cats sailing, absolutely everyone is encouraged to participate, no matter how many hulls their boats have. If you don't have a boat, donations to a good charity should get you a berth. We're hoping that this will be the biggest and least serious cruising regatta ever on Banderas Bay. Details to come.

"We recently saw your posting on a Seven Seas Cruising Association (SSCA) bulletin board item regarding the clipping that occurs on some Icom 802 SSB radios," write Roger and Patricia Bruce

YOUR SECRET PARADISE...

Located in a beautiful sheltered lagoon on the north Pacific coast of Nicaragua, Marina Puerta del Sol is your premier cruising destination in Central America

- Onsite Immigrations & Customs
- Full service restaurant and bar
- 24 hour security patrol
- Internet & Fax/copy service
- Yacht club with showers and laundry

- 140 foot fuel dock - diesel/gasoline
- Well marked channel
- 40 slips with water, power and cable TV
- Two pools, oceanside and marina
- Tennis, surfing, fishing, horseback riding
- Luxurious hotel with 19 executive suites



Marina Puerta del Sol

Aserradores, Nicaragua • 011 (from US and Canada) 505-883-0781 mpuestadelsol@yahoo.com • www.marinapuestadelsol.com • USA 408-588-0017

...IN BEAUTIFUL NICARAGUA

of the Hylas 49 **Iolea**. "We're presently in Singapore, well into our circumnavigation, but have had no end to our clipping problems with our 802. We FedEx-ed the unit back to Icom in Washington earlier in the year, but it still clips. Do you have any suggestions on how to get this resolved?"

It's our understanding that Icom came up with an initial modification, but later learned it didn't solve the problem. A second 'mod' wasn't the ultimate fix either, so they now have a third one which reportedly takes care of all the issues. Our 802 got one of the early 'mods', so Icom suggested we send our radio back a second time. We think they're on top of the problem now, and suggest you contact them to find out whether or not you got the final 'mod'.

If you checked out the September 19 *'Lectronic*, the Photo of the Day was of Aron, a young Hungarian man who had sailed his somewhat weather beaten 19-ft **Carnia** all the way from Europe to the Marquesas. According to Liz Clark of the Santa Barbara-based Cal 40 **Swell**,

who took his photo and sent in the brief report, it had taken Aron 52 days to make the 3,000-mile passage from the Galapagos to the Marquesas. We salute Aron for his big achievements with such a little boat! As for Liz, she's been kicking around the Marquesas and Tuamotus, *looooving* the cruising life and the almost empty waves at certain secret surfing spots. In fact, based on her latest stream-of-consciousness writings — which we plan to publish next month — Liz may be starting to 'go native'. While at White's Landing last month, we bumped into Liz's parents on their Gulfstar 50. They told us that when Liz was young, she'd so completely throw herself into physical activities that she'd come to the dinner table exhausted. After



'Iolea' on the hook at Bora Bora. Her Icom 802 SSB 'clipped' there, and much to the Bruce's dismay, is still clipping today.

a minute or two, she'd nod off, her head falling face first into her mac & cheese. They say she really hasn't changed that much.

"You may not remember me," writes Richard Fieber of Fort Meyers, Florida, "but I still have my '95-'96 Ha-Ha T-shirt — even though I actually made my 18-day passage to Cabo before the start of the then two-year-old event. I'd gone

Your Boatyard in the Heart of Paradise



Large, fenced, secure dry storage area

Tahiti Customs policy has changed!
Foreign Flag vessels can stay on dry storage in our yard for up to 12 months out of 24.

Our Services |

HAULOUT

- Marine Travelift 25 tons
- Marine railway 120 tons
- Storage in adjustable steel cradles
- Fenced Yard

PAINTING

- Topsides, hull, bottom, varnish
- Brush, roller, spray

MECHANICAL WORK

- Inboard, outboard, diesel, gas
- All brands

REPAIRS

- Electrical repairs
- Refrigeration installation & repair
- Fiberglass & woodwork
- Welding, steel, stainless, aluminum

SAIL LOFT

- Sail repairs, biminis, dodgers, covers

STORE

- International, Pettit, Epiglass, Devoe
- Spares
- Fill U.S. gas cylinders

DO-IT-YOURSELFERS WELCOME!

BoatUS Cooperating Marina



Professional boatyard in the heart of Paradise



A Subsidiary of
The Moorings Yacht Charter, Ltd.

*Raiatea Carenage will make sure
paradise is everything you expected.*

Call, write, or sail in . . . we're here to serve you.

B.P. 1111 Uturoa Raiatea 98 735 Polynésie Française

Tel: (689) 600-545 ~ Fax: (689) 600-546 ~ VHF 68

Web site: <http://raiatea.com/sailing/carenage/> ~ email: raiateacarenage@mail.pf

CHANGES

down a couple of weeks early aboard **Kiwi**, my 42-ft kauri wood ketch. Unfortunately, I would lose her a few months later off Nicaragua. After flagging down some shark fishermen for much-needed water 10 miles offshore, I started to tack down the coast in a strong *papagayo*. When I got in to about four miles from the coast and it was time to tack, I fell asleep. The next thing I knew, the boat had gone up on a reef near Sandino! The waves were about four feet, so my boat was damaged beyond repair almost immediately. So I grabbed my cat and important papers, stuffed them inside my jacket, and made my way through the surf to the shore. My cat jumped out, ran down the beach, and I never did see her again. I got into the jungle at the water's edge about 4 a.m. and started walking to some distant lights. I was afraid that some kind of wild animal — I wasn't really sure what kind — would get me. But I made it. About four years later I got my current boat, the Irwin 33 **My Brother's Keeper**. I christened her that because I've done a bunch of missionary work in Mexico and Central



MY BROTHERS KEEPER

The world's greatest windscoop? We don't know about that, but inventor Richard Fieber thinks so.

America. My goal is to help people who live in houses with just one light and no running water, of which there are many in Mexico and Central America. I also want to help communities where they do

things like put the outhouse at the top of the hill and a sewage-contaminated community well at the bottom. Anyway, I'm writing because I invented the world's greatest windscoop, one that actually works when it's blowing. If anyone is interested, they can reach me at www.freewebs.com/3sidedwindscoop or richfieber@netzero.net.

"It's finally happening!" reports Robert Watson of Carmichael. "I'm nine years into my five-year plan to cruise the world, a seeming contradiction that can be explained by work and women getting in the way. But now they are all over and done with — I think. In any event, my Leopard 40 catamaran **Changing Spots**, the baby cousin to the popular Leopard 45s and 47s, is currently being built in South Africa. I don't get to take delivery and move aboard until after she's featured at the Miami Boat Show next February. I'm coming down in the boat world from three hulls to two, and will no longer get to rely on training wheels. I recently sold my Corsair F27 trimaran **Three Play**, which I'd owned for 20

LET MARINA EL CID WELCOME YOU TO MAZATLAN!

Cruisers -
**FIRST
NIGHT
FREE***



Official
Sponsor
2007
BAJA
HA-HA

**A CRUISER'S PARADISE IN THE HEART OF MEXICO'S
LUSH TROPICAL COASTLINE AND BEAUTIFUL ISLANDS**

A Full Service Marina Offers...

- ★ 90 slips from 25' to 120'
- ★ Electrical and water hookups
- ★ Telephone connections
- ★ Restrooms and shower facilities
- ★ Dock Boxes
- ★ Dock Carts
- ★ 24-hour security
- ★ 24-hour laundromat
- ★ Supermarket
- ★ Dry dock
- ★ Gasoline – Diesel
- ★ Pump-out station

NEW Marina-Wide High Speed Wireless Internet Connections!

www.elcid.com

011-52 (669) 916-3468 • gcevallos@elcid.com.mx

***Reserve for any multi-day stay and your first day is FREE!**

MARINA REAL

SAN CARLOS, SONORA, MEXICO

IN THE SEA OF CORTEZ

Located on the Mexican mainland near Guaymas and San Carlos, 265 miles south of Nogales, Arizona.

- 350 slip marina • 20 & 30 amps electrical service
- 24-hour security patrol
- Fuel dock with gasoline/diesel
- Restrooms & showers
- Web email • Fax/copy service
- Port entry clearance
- Book exchange • Video loan library
- Ice & bottled water
- Wet storage for summer months (low prices)

Now Offering:

Haulouts, Dry Storage & Service Yard



Phone/fax 011-52-622-2270011
Call on VHF #16 when in area
email: marinareal@prodigy.net.mx

Visit our website:
www.marinareal.bravehost.com

years. Built in '87, she was the first F27 in Northern California for a long time, and we used her extensively around the Bay and Delta, as well as Southern California, Lake Tahoe and even Baja. She was a lot of fun screaming across The Slot at 15 knots — even singlehanded. Now she'll be going to the relatively gentle waters of Southern California."

If you're headed south, you're going to want to make an investment in **boat cards** to pass out to all the new friends you're going to make. Naturally, you're going to include your name, boat name, boat type and hailing port, as well as your phone, satphone, email, and SSB/ham/Sailmail/Winlink address. Lots of folks like to get really creative with their cards, using all kinds of exotic types and bolds and italics. Don't! Too often such cards are so 'creative' nobody — particularly those without reading glasses — can read them. So keep the look of your boat cards clear and simple. Another mistake people make is putting photos of their boats on their cards. We understand that they are proud of their boats, but

it would be more helpful to others if they put a photo of themselves on the cards, as that's what will really help others remember you.

"We took ownership of our boat in late July of last year, just 10 weeks before we took off on our cruise," report Dan Zuiches and Danielle Dignan of the San Francisco-based Farr 44 **Confetti**. "It's been a fantastic whirlwind year that saw us sail 12,000 miles to Mexico, the South Pacific, and Hawaii — with us now being halfway back to San Francisco. "Our offshore average speed was 6.5 knots, we only burned 300 gallons of diesel in the whole year, and despite seven crew changes were able to stick to a rigorous



Danielle Dignan at the helm of 'Confetti', ripping along at speeds that gave them a 6.5-knot average speed when sailing offshore.

schedule." Much more from Dan and Danielle next month.

Next month we're also going to have a great report from the Hinson family — dad Dale, mom Dawn, Danielle, 11, and Darby, 10 — who converted their 22-year-old Long Beach-based Olson 40 **Pythagoras** into a family cruising boat. Starting with the Ha-Ha, which they

Peaceful Southern San Diego Bay

**BOATER'S SWAP MEET
OCTOBER 6
7AM-1PM**

HOME OF CHULA VISTA MARINA

552 slips with complete amenities from private dock boxes to pool and jacuzzi to ample free parking.

Come feel the South Bay difference.

Permanent or temporary berths available.



(619) 691-1860

Dockmaster's office open 7 days a week

boatslips@cvmarina.com

www.chulavistamarina.com

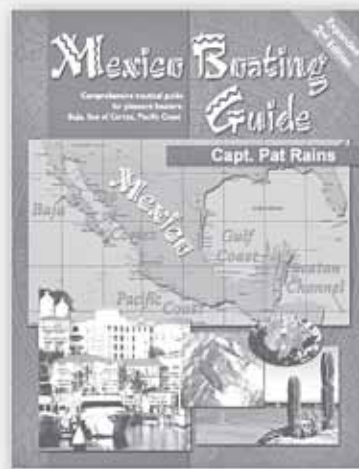

Mexico Boating Guide

Capt. Pat Rains
nautical guidebook
2nd Edition

"The Cruisers' Bible"

- More detail in *entire* Sea of Cortez!
- 200 Charts are GPS- & Satellite-accurate
- 350 color Photos & Satellite Images
- Port-clearance, blank "Crew List" forms
- All Pacific Mexico. New "Resource Guide"
 - By American USCG-licensed Captains
 - Concise, professional, no fluff!

order online or phone

toll free (888) 302-2628

www.MexicoBoating.com

CHANGES

loved, they did a 10-month, 4,000-mile cruise, which they loved even more. As a preview for their piece in the next issue, we'll leave you with this description of one of the highlights of their trip:

"We'd just left the dock at La Paz, and our engine died, leaving us adrift in the channel with no way to maneuver," writes Dale. "I decided that I would grab a line and swim it to the dock, then pull the boat in. My wife thought it would be a better idea if I stayed on the boat — she was right — and that she would swim the line in. "No," our 11-year-old daughter Danielle quickly said, "I'm a better swimmer than mom, I'll do it". With that, she grabbed the line, dove in — clothes and all — and swam the line to the dock, where she and a man pulled our boat back to safety. It was so awesome to see our young daughter act so bravely and selflessly to save our family and boat, and great for her to have the chance to be a 'hero'. I don't think she'll ever forget it."

"Last month the **sea turtles** found a quiet spot on the beach just east of the *panga* marina at Punta Mita to lay their



DALE HINSON

'D' best? Darby, Dawn and Danielle Hinson had a great 10-month cruise aboard the family Olson 40 with 'D' dad, Dale. Much more next month.

eggs," reports Kati Milleson, who in a condo on the beach. "In one day, the local marines and I helped collect 1,300 eggs from the 15 nests along our stretch of

beach. We took the eggs to a sanctuary for protection. If left on the beach, the locals would have taken them because they are considered to be valuable aphrodisiacs. Once the little guys hatch, they'll be return to the same stretch of beach for launching back into the ocean." "It's terrific that the eggs are being protected, because there's few cooler things than seeing a turtle on the ocean while sailing, or even better, crossing paths with a big one while snorkeling. A few years ago we visited a sanctuary near Paradise Village Marina, where they launched 50,000 day-old turtles each year. That sounds like a lot, but infant turtle mortality runs about 95%. Richard Bernard of the Hawaii and Anacortes-based Valiant 40 **Surf Ride** reports that turtle egg preservation efforts in Hawaii have resulted in a big comeback for turtles in the Islands, too.

Oh baby, the **new cruising season** is almost on us, and we're jacked! The only thing that could make us happier is if you folks remember to send us mini reports and hi-high res photos.

YACHT INSURANCE

Pleasure
Yachting

and

Commercial
Operations

Best selection
of Marine
Underwriters
for Safe Risk
and Asset
Protection



- YACHT POLICIES
Offshore, Coastal, Inland
and Liveaboards
- COMMERCIAL POLICIES
Marinas, Yards,
Yacht Clubs, Brokers,
Shipwrights
- FULL SERVICE
BROKERAGE
Auto, Home,
Business

Lic.# OB21939



BILL FOWLER

McDERMOTT COSTA INSURANCE

(925) 606-6606 • Fax (925) 606-6216
bfowler@mcdermottcosta.com

Alameda Prop & Machine Stainless Custom Fabrication!

We Guarantee at Least 5% Savings
Over Any Competitive Fabrication Quote!*



Integrated Bow Rollers



Basic Arch
as low as
\$3,000!

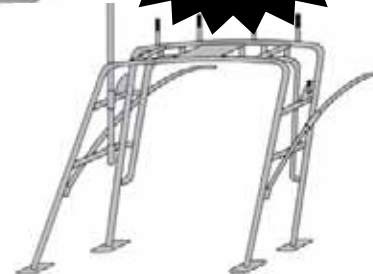

*Call for details

Alameda Prop & Machine
at the Grand Marina Marine Center
(510) 522-7899 (800) 774-7899

How do you find *Latitude 38* in Horta Harbor, Azores?



Sign up at: www.latitude38.com

Subscribe to *Latitude 38's* E•Books ~ Just \$18/yr.

The full version of *Latitude 38* is available online in complete magazine format.

Don't miss a single issue.



DF DIESEL FUEL FILTERING

since 1989*

Superior equipment and years of experience guarantee results - Don't settle for less.

Purify Diesel Fuel & Flush Tanks.

Process scrubs; polishes; removes algae, dirt, rust and water from diesel fuel.

Includes internal tank washdown.

Save your injectors, costly engine repair and down time.

We are in compliance with State and Federal Specifications & pollution control.

- "All Pleasure Yachts & Commercial Craft."
- Your berth or boat yard.
- Fully Insured

(510) 521-6797

Fax: (510) 521-3309



*Owned and operated by Bob Sherman since 1989



CORAL HOTEL & MARINA
Ensenada, Mexico

INCREDIBLE SAVINGS ON FUEL AT MARINA CORAL!
Call for a quote ~ 866•302•0066



- The only fuel dock & best launch ramp in Ensenada
- Concrete docks from 30' to 65' with 110v/220v elect., water, cable TV, phone service and wireless internet, laundry, marine chandlery.
- Enjoy the amenities of the 147 ocean view suite resort which will make your stay the most enjoyable.

www.hotelcoral.com

Reservations toll free **1-866-302-0066**

E-mail: marina@hotelcoral.com Fax-011526461750058 VHF 71
Carretera Tijuana-Ensenada Km. 103, No 3421 Zona Playitas, Ensenada, B.C. C.P 22860

Please read before submitting ad

Classy CLASSIFIEDS

- 1. Write your ad. Describe what you're selling. Indicate category. Don't forget price and contact info.** Be neat. We aren't responsible for errors due to illegible writing or unclear meaning. We make final placement determination.
- 2. Count the words. Anything with a space before and after counts as one word (eg, phone number, email address, price). We'll spell-check, edit and abbreviate, as necessary.**
- 3. Mail your ad. Enclose check or money order, or deliver to our office with cash, or ...**

Post your ad safely online with Visa, MasterCard or AmEx at: www.latitude38.com

Personal Ads

1-40 Words: \$40
 41-80 Words: \$65
 81-120 Words: \$90
 Photo: B&W \$20
 Photo: Color \$30
 • Personal Advertising Only •
 No Business/promotional ads except Non-Profit, Job/Biz Op.

Business Ads

\$70 for 40 Words Max
 All promotional advertising
 1 boat per broker per issue
 Camera-ready art OK
 No photos/reversals
 No Extra Bold type
 Not to exceed 12 pt font
 Artwork subject to editor approval.

'Trying to Locate' Ads

Searching for People: \$10 for 20 Words Max
 All ads will be set to fit Latitude 38 standard.
 Re-Run Ads: Same price, Same deadline.

Mail (or bring) to: **Latitude 38**
 Attn: Classified Dept
 15 Locust Ave, Mill Valley, CA 94941
 Questions?: (415) 383-8200, ext 104 • class@latitude38.com

DEADLINE

is always the

18th at 5 pm

of the month prior to publication. Due to our short lead time, deadlines are *very strict* and include weekends & holidays.

- No ads without payments
- No billing arrangements
- No ads accepted by phone or fax
- No verification of receipt
- We reserve the right to refuse poor quality photos or illegible ads.

DINGHIES, LIFERAFTS AND ROWBOATS

DBC 8-PERSON RACING PACK liferaft in good condition. \$500. New in December, 1999 for the 2000 Pac Cup, then stored in clean, dry conditions. Never serviced so needs looking at. Service shop thought that this might cost \$250-\$800. Call (408) 504-0998 or jimhurst100@hotmail.com.

SEA EAGLE 395PS PADDLESKI. Go to: <www.tackletour.com/reviewse395.html> for details. Great for Mexico. See my other stuff in 'Gear'. Asking \$400/obo. Craig (916) 721-3832 or svchances@comcast.net.

AVON ROVER 3.1 DINGHY. Hypalon, takes 10-hp outboard. 10.5 feet, no leaks, plywood floor, 2 bench seats, new valves, planes easily with 2 adults, \$800. Plastimo 4-man offshore liferaft in valise. Needs recert, will guarantee certifiable. \$800. (510) 734-0492.

2007 APEX A-17 TENDER, with Johnson 115-hp 4-stroke, electric fuel injection, 10 hours TT. Off-center console, white hull, gray tubes, black trim. New condition. Used as temp tender on mega-yacht. Priced for prompt sale at \$22,500. Located LB, CA. Call for photos. (562) 901-2470.

MX-RAY, 1998. Excellent condition. Super fast and easy to sail. Carbon fiber mast, Mylar main, easy-launch spinnaker. \$2,500/obo or trade for nice Laser. (707) 764-3536.



24 FEET & UNDER

BEAR BOAT #52, 1949. \$10,000/obo to secure a good home for *Juno*. 90% restored, but now needs regular maintenance. Restoration included keel bolts, sistered ribs, refastened hull, new deck structure, new cabin, new deck glassed canvas and sanded, new boom. Original hardware, varnish in good condition, in need of paint. Decent sails: 1 main, 2 jibs, old and new spinnakers. Terrific upwind Sausalito Yacht Harbor berth. Bruce (510) 558-0300.

CHRYSLER 22, 1977. Dual-axle trailer with 2 new wheels and tires. 2004 Mercury 8-hp 4-stroke ob. 3 mains, 3 jibs, spinnaker with pole. New forestay, backstay, and keel pendant. Located San Jose, CA. Asking \$3,800. Email: boatad@katzhome.net or call (408) 203-3471.



CAT YAWL BY SHELL BOATS, 2005. 12'11" long, 1/4" Philippine mahogany hull, 100 lbs, 55" beam. Dacron sails, spruce masts. Oars, cover, dolly, lift system. \$2,400. (949) 400-9856 or rkleishman@hotmail.com.

CALT/4 QUARTER-TON, Jensen Marine. 24' x 8' x 4'. Main with jiffy reef, 110, 135 jibs, spinnaker. Sail controls led to cockpit. 6-hp Evinrude. Balanced, stiff, responsive, fast, fun. Big V-berth, roomy cabin with 2 berths. Cosmetics fair. Oldie but goodie. \$2,950. (530) 828-9854.

WEST WIGHT POTTER 19, 1987 and trailer. 8-hp outboard, newer red sails, new VHF, GPS plotter, depthsounder. Two rudders, all USCG safety gear. Trailer has new hubs, bearings, tires. All good condition. \$5,800/obo. (831) 475-6869 or surfdawg@scshop.com.



KRAZY BULL: KIWI DESIGNED, built and maintained. Offshore ready. Designed as a Bull 7000. 23' scoop added and rudder box extended aft to gain offshore cat1 requirements. Asymmetric kites and pivoting, retractable sprit. Diax main, #3 blade, #2, #1 genoa, drifter reacher. Offshore racing at speed then trailer at 55 mph. Stove, crapper, 6-hp ob. Sleeps 4. Sturdy, safe, fast. \$23,500. Call (360) 695-5440 or email: kzboats@aol.com.

12-FT SF PELICAN. Smith-built with Honda outboard. Located in Stockton. \$1,700. Bob (209) 952-4444.

ULTIMATE 20, 2000, #144. Race ready and fast, 2-hp Honda, trailer, professional epoxy bottom, new standing and running rigging, practice and new sails, Tack Tick. Located Lake Tahoe. \$27,000. Email: geoffreygardner@msn.com.



24-FT STONEHORSE SLOOP. Edey and Duff, 1974. #47 OF 150. All original. 5-hp Westerbeke diesel. Perfect weekender. SF City Marina slip. Edey and Duff trailer. Needs brightwork. \$15,000. Fred (415) 726-6036.

25 TO 28 FEET

NOR'SEA 27, 1978. Completely refurbished. All new: Radar, instruments, depthsounder, diesel heater, self-furling jib, stove, bilge pump, 12v fridge, batteries, wiring, plumbing, head, windlass, stanchions, lifelines. Rebuilt 2-cylinder diesel SAAB, full feathering prop, VHF, CQR and Bruce anchors. Lazyjacks, cutter rigged, excellent sails, hull waxed, Trinidad bottom paint 8/07, teak cabinets with cane insets, teak and holly cabin sole, perfect upholstery. 2-axle trailer with new brakes. Ready to go anywhere. Captain getting old. \$40,000. (831) 338-4233.



NOR-CAL COMPASS ADJUSTING

Magneuto™ System Exclusively
 Boat Remains in Berth • Eliminates Deviation
 Authorized Compass Repair • All Major Brands
 Hal McCormack • Phone/Fax: (415) 892-7177

CHART SAVINGS UP TO 75%

HIGH DEFINITION PRINTS • 256 INCREDIBLE SHADES!
 Worldwide • Sample Chart \$7.95 • Affordable E-Chart back-ups
 Bellingham Chart Printers Division, TIDES END LTD., PO Box 397L, Shaw Island, WA 98286
 800-643-3900 • fax: 360-468-3939 • www.tidesend.com • sales@tidesend.com

VOLVO PENTA

Specialist Dealer Since 1980
 ESKELUND MARINE • (510) 523-7670
 1913 Clement Ave • Alameda Marina • Bldg 13 at Pier 2

C.C. RIGGING

Sales and Installation
 (510) 338-2165

MacGREGOR 26M, 2004. Very good condition, 50-hp outboard with less than 100 hours, roller furling genoa, rotating mast, VHF, GPS, trailer. Located in Santa Cruz. \$22,500. Email Jeff: marylouandjeff@comcast.net for complete list of items.



1997 25-FT CUSTOM GAFF-RIGGED cutter. Featured in the June issue of *Latitudes & Attitudes* magazine, this amazing cruiser is simply beyond compare. Berthed SF Bay. Call or email for details. \$37,500. (805) 458-6916 or Roger.Burson@am.fostersgroup.com.

ERICSON 27, 1973. 1988 Westerbeke diesel, 800 hours. GPS plotter, new cockpit and interior cushions, Force 10 heater, roller furling, spinnaker, new bottom paint. A very nice boat. Located Emeryville. \$9,500. Call (707) 964-7917 or (707) 357-1309.

25-FT NORTHSTAR 500 SLOOP, 1973. Heavy little Bay boat, old racer, redundant rigging. 5-ft draft, fin keel, skeg rudder. New Atomic 4 with freshwater and electric ignition, big alternator, low hours. Sleeps 4, new VHF marine speakers. Fair condition, many sails. Moored at Berkeley, no trailer. \$4,000. Make offer. Swede (916) 768-5519.

CATALINA 28 Mk II, 1997. Sailed 3 months/year only in Lake Tahoe. Freshwater boat. See in Reno, on borrowed trailer. \$49,500. Ready to go. Many, many extras. See: <www.nvsailing.org> (775) 852-2320 or rog@nvsailing.org.



SANTANA 25. Clean, ready to sail. Great Bay boat. New battery, halyards, mast wiring. 3 sails: main, 135 jib, storm jib. Berthed at Oyster Point Marina, Dock 9, Slip 16. \$5,000. Call Steve (650) 892-5176.

1980 CAT 25 FIXED KEEL. Roller furling jib. GPS, AM/FM/CD. New 9.9-hp Mercury outboard. Clean. Bottom repainted 2.5 years ago. Records. Pelican Harbor, Sau-salito. Priced for immediate sale. \$3,600. Call Tim (415) 717-4891 or email: Tim@conquestcapital.com.

PEARSON TRITON 28.5, 1962. A gem. 1st place Classic winner So-Bay OP-Day, 2006. 18-hp Yanmar, freshwater cooled. 7 sails including spinnaker. Barient, autopilot, standing headroom. Haulout 4/05. Located Redwood City, CA. (650) 327-0190. Will email photos: cdroth2@sbcglobal.net. Asking \$12,500. Certified check only.

SANTA CRUZ 27, ANDIAMO. Pac Cup ready. Proven winner. Optimized for shorthanded racing. Recent survey. Plenty of sails. New self-tailers. See: <http://www.worthyperformance.com/andiamo/> \$13,500. Please email: mark@worthyperformance.com.



HAIDA 26, 1967. Located in Fiji. Why wait? *Dreamland* is a cruising-ready boat with everything to cruise the South Pacific now. Lots of new stuff and 8-ft fiberglass sailing dinghy. Check <www.myspace.com/saltyben> for pics, specs, more info. \$7,000. Saltyben@hotmail.com.

MacGREGOR 26, 2001. \$19,000. 50-hp outboard, 250 hours. Trailer with spare wheel, enclosed head, galley, GPS speed/depth, roller furling jib, lines to cockpit, jiffy reefing, cockpit cushions and table, bimini, gas BBQ, stern ladder, two batteries, curtains. (510) 490-3575.

RANGER 26, 1973. Berthed Emeryville. North Sails: Spinnaker, two jibs, mainsail with two reefs. 9.9-hp Johnson/Evinrude Yachtwin. New deep-cycle battery, new marine VHF radio. Two-sailboat owner must sell. Price: Make cash offer. (209) 942-2136.

ERICSON 27, 1978. New instruments and lifelines, wheel steering, new 130 on roller furling, lazyjacks, VHF, CD with cabin and cockpit speakers, BBQ, plenty of sails, spin gear and more. \$9,800. Call (408) 386-5422 or email: warren@navit-gps.com for must-see photos.



25-FT CHEOY LEE VERTUE. #138. New 12-hp Westerbeke diesel, excellent paint job, 4-man inflatable cert. \$21,000. Call Larry (559) 224-3973.

COLUMBIA 26, 1973. Three-quarter keel. Outboard well, no motor. Project boat but not beyond capability of anyone who has basic DIY skills. Main and jib. Current registration, clear title Asking \$900. Cash offers only. Gabe (415) 898-1436.

29 TO 31 FEET

CATALINA 30, 1981. New sails. Main and furling jib. Rebuilt A4, 50 hours. Recent re-rig: Standing and running. New spreaders. Mast rewired. Delta shade attaches to dodger. All green canvas. Very nice boat. Clean. Located in San Rafael. Asking \$24,500. (530) 235-4908.

PACIFIC SEACRAFT MARIAH, 1979. LOD 31', LOA 36', LWL 25', beam 10'9", draft 4'5", displacement 16,000 lbs, ballast 6,000 lbs. SA 596 sq ft, headroom 6'5". Fiberglass hull double-ender, full keel, cutaway forefoot. Wheel steering or emergency tiller. Staysail, roller furling foresail, fully battened mainsail. 30 hp Yanmar diesel, serviced 10/06. New standing rigging 9/03. Bottom paint 4/07. Radar, GPS, VHF, SSB/Ham, Muir windlass, more. Loch Lomond Marina. \$69,000/obo. Richard (415) 927-2765.



MOVING FORCES SALE. Kings Cruiser 29-ft sloop, reg. with Lloyds of Shipping, glass on glass. Volvo MD1 diesel engine, forward V-berth, sleeps 2, bunk sleeps 2, head, galley, alcohol stove, sink, original dishes, tiller steering, Garmin GPS, Piranha 4 depthsounder, Raytheon ST2000+ Autohelm, Standard Horizon Eclipse Plus 2-way radio, auto bilgepump, flat screen TV, DVD player. Seaworthy, *ABOBatBarf*, 2nd owner, well maintained. So. San Francisco. (916) 990-4206 (after 5 pm).

ISLANDER 30 Mk II, 1971. 4-cyl gas inboard Palmer P60. Fiberglass with teak trim. 3-burner alcohol stove/oven, BBQ. Depth/fish finder, CB and radio. Recent haulout. New bottom paint, zincs, standing and running rigging, carb, batteries, blower, engine tune up, tiller cover, refurbished mainsail. Sails include spinnaker, 2 storm jibs, 100% and 130% genoa. Mahogany interior. 5 lifejackets, lots of extras. Sleeps 4 comfortably. Good solid boat. Ready to sail. Asking \$11,900, motivated. Call (831) 915-6783 or email: drbradcase@sbcglobal.net.

ERICSON 29, 1972. Universal diesel rebuilt two years ago, tiller, VHF, jiffy reefing, Harken furling and more. \$9,000. (510) 758-0709.

MARINER 31 KETCH, 1969. Heavy-built fiberglass hull has cruising keel with cutaway forefoot. These boats can go anywhere. Many special cruising features, extra fuel and water tanks. Windvane steering system, electric autopilot. D/S VHF stereo, 2-speed manual anchor windlass with 35# CQR, dual bow rollers. 3kw built-in generator set. Head has shower and holding tank. Main and mizzen like new. Perkins 4-108 diesel runs great. Half Moon Bay. \$9,000. (650) 218-6434.

CATALINA 30, 1982. Excellent condition, well maintained. Wheel steering, good sails, roller furling jib, new navy-colored canvas, new cockpit table, knot/wind meters, new companionway doors, microwave, TV, much more. Loch Lomond Marina. \$19,800. Don (707) 227-9262.



WILLARD 30, 1976. Crealock world cruiser, Baja Ha-Ha vet. Perkins 4-108, full keel, great liveboard, Raymarine autopilot, radar/chartplotter, Lofrans windlass, lots more gear. Biggest 30-footer you'll ever see. \$37,500. <http://willard30.blogspot.com> (408) 887-3103.

ERICSON 29, 1973. New sails 2004, Atomic 4 overhaul plus new exhaust 2005. Very clean interior. Located in Berkeley. Low tech. Needs: Mast winch corrosion repair, electrical work. Price reduced \$8,500. Call (510) 289-0355 or jdeboersf@yahoo.com.



CAPE GEORGE 31 CUTTER. *Infinity* is for sale. Gorgeous. Yard-built in 1993. Cruising ready. Loaded. Won't last. Resting in Tahiti. \$125,000. For info see: <www.capegeorgecutters.com> or email: susan_travers@yahoo.com.

ISLANDER 30. Impeccable interior, sleeps 6. New: Harken roller furling and genoa, standing rigging, canvas covers, fuel tank, batteries, bottom paint. Palmer engine, under 115 hours. Wheel, cockpit cushions, 7 winches, main, spinnaker and gear, VHF, depth, speed. \$19,750/obo. (415) 924-2463.



BOAT • LETTERING

alphaboatsue@comcast.net • (510) 599-1197 • www.alphaboatgraphics.com

Creative and durable lettering and artwork for your boat

All-Marine Electronics & Electrical

- ◆ System Design ◆ Troubleshooting / Repair ◆ AC & DC ◆ Quality Installation ◆ Licensed & Insured ◆
- ◆ Radio & RADAR ◆ Antennas & Mastwork ◆ Integrated Navigation Systems ◆ Auto Pilots ◆
- ◆ Battery Monitoring Systems ◆ Alternators, Regulators ◆ Solar ◆

Alameda, CA -- (510) 523-6011

WOODRUM MARINE

Specializing in custom interior cabinetry, tables, cabinets, countertops, cabinsoles. For power or sail.

CARPENTRY
Mobile cabinet shop
Contact Lon Woodrum at:
415-420-5970
www.woodrummarine.com



Private Sailing Instruction

- Individual instruction on your boat to meet your needs and goals
- Certified instructor • 25 yrs experience • USCG 100 ton Master
- Available for skippered charters and West Coast deliveries
- Dan at (650) 325-1147 or elizabethdan@earthlink.net

MARINA DE LA PAZ FULL SERVICE MARINA
S.A. DE C.V.

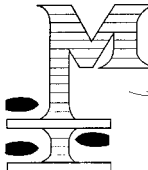

Friendly, helpful, fully bilingual staff

All new hardwood docks • Wireless Internet
Dinghy landing with potable water
New protective piling & sheetpile breakwaters • And more!

TEL: 01152 612 122 1646
email: marinalapaz@prodigy.net.mx
www.marinelapaz.com

Apdo. Postal 290, La Paz, 23000, Baja California Sur, Mexico

BDI
MARINE SURVEYS & DELIVERY CAPTAINS

Pre-purchase and Insurance Surveys
Serving the Entire West Coast
30+ Years of Experience
More than 20,000 Miles at Sea
Power and Sail

(707) 526-2418



GOLDEN STATE DIESEL MARINE

PARTS
YANMAR • UNIVERSAL • WESTERBEKE
PERKINS • ISUZU • PATHFINDER • ATOMIC 4

SERVICE
DIESEL ENGINES

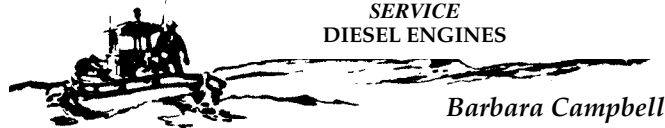

Barbara Campbell

351 EMBARCADERO
OAKLAND, CA 94606

(510) 465-1093

PRODUCT DESIGN
FOR THE MARINE AND
WATER SPORTS INDUSTRIES
**MECHANICAL & ELECTRICAL
ENGINEERING**



DESIGNS

E-M DESIGNS
171 Ocean Blvd.
Box 97
Half Moon Bay
CA 94019-0097
650-720-3408
www.emdesigns.com

CATALINA 30, 1979. Wheel steering, newer Kubota diesel, Doyle StackPack, full batten, double-reef, lazyjack main in 2005 (not pictured). Self-tending jib, also have 110% jib, updated interior. VHF, BBQ. Fun and easy to sail. \$16,999. (510) 495-4522.

OLSON 30, 1983. FAMILY HOUR. Turn-key boat. Stiff hull and all class-approved stiffeners. Clean. Double spreader rig. 22 bags of sails. Keel and rudder faired. Numerous upgrades. Trailer. One of the most winning Olsons on Bay. \$20,000. (925) 934-6926.



ALLIED SEAWIND 30, 1970. Located Everett, WA. Well maintained, many upgrades, new fridge, new stove/oven, new cabin sole, new head, 6 sails, furler, radar. \$30,000. See on www.yachtworld.com > Call Richard (360) 658-8401.

IRWIN 30 CITATION SLOOP, 1977. Yanmar engine, new sails, roller furling, many more recent upgrades. Possible Sausalito berth. Asking \$16,500/obo. Call (415) 302-1960.

CAL 2-29, 1975. Wheel, dodger, fore and aft anchors, Pineapple sails. Raise/lower engine mount bracket and 18-hp Nissan 4-cycle, low hours, with large capacity fuel tank. New deep-cycle batteries. Two-sailboat owner motivated. Price: Best cash offer. (209) 942-2136.

CATALINA 30, 1975, #115. Too much to list. New mast, roller furling, new headsail, restored teak interior, propane heater and oven, radar, GPS, lines led aft, tiller, Yanmar 12-hp. Transferable Treasure Island slip. \$12,000/obo. Call Bill (415) 310-4692.

32 TO 35 FEET

HUNTER 34, 1984. Wonderful Bay boat and beyond. Spacious cockpit and below decks. Perfect liveaboard. Microwave, alcohol stove and oven. Yanmar diesel. Roller furling jib, dodger, extra sail. Hauled and painted 8/06. Sausalito. \$29,000. Call Commodore Saltonstall (707) 658-2581 or email: sam@saltonstallestate.com.

MARINER 32, 1979. Great solid boat. Perkins diesel, water heater, roller furler, alcohol stove, new VHF radio, new varnish. Complete bottom job 2006. Well maintained. Located Brisbane, CA. \$28,000. Call Matt (408) 732-7340.

CAL 34 Mk II, 1977. Diesel. Lots new after 2-year refit. New: Interior cushions, electrical system, mainsail, topside paint, Dickinson diesel heater, refrigeration, GPS, depthsounder, 555 windlass rode and anchor, legal head, running rigging, all deck fittings rebed, thruhulls replaced, Westerbeke 30 just serviced, Much more. Located Gig Harbor, WA. \$23,900. (253) 468-1485 or gamersmarket@gmail.com.

ALBERG 35, 1965. Diesel, windvane, radar, much more. Needs minor work. Good condition. \$19,000/obo. Call Mark Eilers (707) 971-0537.

MOODY 34 CENTER COCKPIT sloop. Roomy cruiser built in England to Lloyds of London specifications. Crossed Atlantic and Pacific. 35-hp Thorneycroft diesel, new Larsen roller furling jib and UK asymmetrical spinnaker, VHF radio. Hauled, painted, new prop 6-07. Slip in Moss Landing, \$37,500. (831) 685-1815.

CATALINA 320, 2006. Selling due to illness. 53 hours on Yanmar engine, ultra-leather interior, dodger, cockpit cushions/table. 8" LCD RAY C80 chartplotter, RAY 60 wind/knot/depth/repeater. 2-kw radar, ICOM VHF, autopilot ST4000. 6' fin keel, Martec prop, many extras. \$132,000. (408) 353-3393.



BENETEAU OCEANIS 350, 1991. 34 feet. Well equipped and in excellent condition. Raymarine radar/GPS/autopilot/plotter, windlass, SSB, VHF. New rigging 2006. 28-hp Volvo diesel. New maintenance-free batteries. 4 sails, full cockpit canvas. Beautiful custom interior, new oven, water filter, many extras. Berthed Richmond. \$69,500. Call (530) 272-7157 or email: mike8140@aol.com.

ERICSON 35 Mk III, 1984. Universal 32-hp diesel with new transmission, new rigging and ProFurl roller in June 2004. Hood 110% jib in June 2005. Harken Big Boat traveler in June 2006. Whisker pole, cruising spinnaker, new plumbing, separate shower stall, new stereo with speakers with iPod connection. A/C and heater, full galley, refrigerator, freezer, CNG stove/oven and many more upgrades. Coast Guard-licensed vessel. Must sell. \$52,500. Call (415) 519-7007 or see: <http://homepage.mac.com/wjblackburn/boat/>

5.5 METER, CARIBBEAN LIGHTS Boat of the Year, 2004. VC 17 bottom, freshwater only, dry dock. S.S.C. \$4,000. Terry (209) 610-7643.

Marine Architecture

John Seward
105 Edison Ave.
Corte Madera, CA 94925
(415) 924-0429 • nims65@gmail.com

Marine Construction

Millerick Bros. Coast Marine
PO Box 357, Cotati, CA 94931
(707) 829-2507
(707) 823-1954 (fax)

Brochure Available



MARINE SURVEYS • Jan Van Sickle
Member: SAMS – AMS, ABYC & IAMI
Ultrasound Thickness Testing of Steel & Aluminum
jtvs@post.harvard.edu • www.vintageyachts.org
(707) 939-9131 • No travel charge within Bay Area

ALLIED SEA BREEZE 35 SLOOP, 1964. All glass, full keel, aluminum rig, Yanmar diesel, turnkey condition, super clean and fully equipped for local cruising or daysailing. Dark green hull, teak trim. Two-boat owner. \$28,500. (562) 706-4334 or sailfast6@verizon.net.



BEAUTIFUL JOHN HANNA WOOD ketch. Designed in 1928, before Tahiti. Classic *Spray*-type hull. Built 1958. 34' LOA, 28' LOD. Lots of romance of the sea: Gleaming deck, spars, fittings, ratlines, belaying pins, Sampson post, two skylight hatches, bowsprit with chain whisker shrouds and dolphin stay, tiller. V-P MD-2 diesel, VHF, new wiring. Pretty interior. Price includes haulout, with best anti-fouling bottom and prop paint, zincs – all the work she needs right now. Berthed Napa. \$23,000. (707) 226-6060.

1995 MELGES 32 FIRST GENERATION with trailer. Southern Spars carbon fiber mast. Carbon fiber spinnaker pole. 2002 4-stroke 6-hp Mercury outboard. Tacktick wireless electronics. Huge almost-new sail inventory. Asking \$57,000. (530) 583-5150 or johnscorda@hotmail.com.

BRISTOL 35, 1970. Offshore equipped. 4-person liferaft 2005, EPIRB 2005, newer Yanmar 27 hp, sea anchor, Fleming windvane. 2005 Hasse trysail, storm jib. 2005 upgraded electrical, rigging, storm windows. Clean, comfortable cruiser. \$33,000/obo. La Paz. (360) 774-0918.



35-FT DUFOUR 4800, 1981. Seaworthy, totally outfitted. Two cabins, salon double. Volvo MD11C, new batteries, new anchor windlass, GPS, VHF, autopilot, Raymarine Tridata. Dinghy, 5-hp Yamaha. Photos: <www.boats.com> Cruise ready for you in Croatia, 1,100+ islands waiting. \$52,545. jhale85@yahoo.com.

NEWPORT 33 SLOOP, 1984. Wheel steering, Universal 21-hp diesel, new prop, Harken furler headstay, lazyjacks, full spinnaker gear, 2 mainsails, 4 jibs, hot/cold pressure water, 3-burner CNG stove/oven, teak interior, new upholstery. \$25,000. (510) 843-0793 or email: crjchem@pacbell.net.

ERICSON 35 Mk II, 1980. Beautifully maintained. New: Roller furling, headsail, prop strut, autopilot, lazyjack system, heat exchanger, fuel and holding tank, running rigging, fuel filter. Newer canvas/upholstery. 3-burner CNG stove/oven. Wheel steering. Varnished teak. Rebuilt mast step. In SF area. Set up for Bay and offshore sail. All hard stuff done. She's ready for fun. \$33,000. Jay (916) 997-4541 or celtica11@yahoo.com.

ISLANDER 32 SLOOP, 1964. This is a project. There is no engine. The hull is good, no blisters. Bulkheads need retabling. It's in the way of a construction project. A great deal for someone with the desire and skills. (805) 434-2135 or tj.nelson9684@sbcglobal.net.

CATALINA 320, 1993. Pristine condition. Very little wear on new engine and rig. Motivated seller. Price reduced to \$60,000/obo. Call or email for pics and details: 320@ideasoup.net or (510) 548-9986.



32-FT DREADNOUGHT FULL-KEEL double-ended cutter. Heavy fiberglass construction, solid offshore-capable design. Origo stove, icebox, VHF, Volvo MD2B. Working jib, genoa, staysail and new main. Simple boat in good condition. Pictures on: <www.yachtworld.com> Lying Channel Islands. \$19,900/obo. (760) 934-4413.

WYLIE 34, 1980. Excellent condition. Presently rigged for singlehanding. Rebuilt standing rig by Easom Racing, New Quantum Fusion X sails with Strong Track and battens. New NX2 instruments, new Harken roller furler, new running rigging, new electric panel and new sail cover. 18-hp Yanmar runs great. Bought a bigger Wylie so this one must go. Make an offer, asking \$29,500. See Full details plus pictures at <www.tillerduck.com> Call Rick (916) 207-1887.

ERICSON 35 Mk III. Too much equipment to list. Ready for blue water. Inside is beautiful, like new. Radar arch, cockpit enclosure, solar panels. Spinnaker. This is a great boat in excellent condition. \$54,000/obo. Call (209) 986-5906 for details.

PETERSON 34, 1978. REDUCED. Comfortable cruiser, successful racer, 15-hp diesel, CNG stove/oven, sleeps 8, fully equipped for ocean and Bay racing. \$19,900/obo. Email: ammc2006@sbcglobal.net.

CAL 34, 1969. Solid glass layout. Atomic 4, new tank, blue hull, basic gear. In Napa, CA. \$17,500. (415) 640-8053.

PEARSON 35 CB. Pearson quality. Wheel, roller furling jib, hot and cold water, stove, oven. Westerbeke 30 hp, 900 hours. Great Bay, Delta, coastal boat, shoal draft with centerboard. Sleeps 6. New Raymarine autopilot and wind/depth. Raymarine GPS, VHF radio, stereo CD with great saloon and cockpit speakers. 2 anchors, extra sails and spinnaker. Ready to go. In Sausalito. Roomy cockpit with dodger. Just redone brightwork. \$34,800. Call Mark (415) 331-6200.

ERICSON 32, 1974. Alameda, CA. \$10,000/bottom, Yanmar 2-cylinder diesel, lazyjack, main. Needs some woodwork. You could call me if you have any questions. Jeff (510) 428-4727 (day) or (510) 881-5672 (eves) or Jeff.Blum@e2.com.

36 TO 39 FEET

SPARKMAN & STEPHENS DESIGN. 38-ft, built 1971 in South Africa. Sturdy full-keel cruiser, fiberglass hull. Yanmar diesel, center cockpit. Owner moved, can't finish. Shown in San Diego 8/18 to 8/30. \$14,300/obo. For more details call: (808) 651-6446 or randyredtime@yahoo.com.



CAL 39, 1978. Rebuilt engine and transmission. New tapered double-spreader mast, new refrigeration, radar, windlass, below-deck autopilot, headliner, port lights and watermaker. Hard dodger and bimini with new canvas and solar panels. Much more. \$79,000. (417) 337-9360.

CATALINA 36, 1986. Diesel, wheel, autopilot, radar. Beautiful condition. Main, roller jib, spinnaker. 2-station Raymarine GPS and radar. All electronics including autopilot integrated on color pedestal display. Refrigeration, pressure hot and cold water, macerator, brand new head and plumbing. Large LCD TV, DVD player, 4-speaker CD. Perfect upholstery, custom mattress. Teak and holly floor and all exterior teak stripped and varnished, new canvas and dodger as well as new bottom paint all this year. \$59,000. (415) 233-1350.

ISLANDER 36, 1980. Like-new Yanmar diesel. Roller furler. Cruising spinnaker. Baja Ha-Ha vet. Autopilot, navigation electronics, SSB, electric windlass. Average to good condition. \$44,000. Mike (510) 644-1217.

HANS CHRISTIAN 38T, 1979. Bluewater cutter. Bottom and batteries 2006. Full keel. Tons of equipment. List upon request. Good sails and engine. AB Cold Plate 2003. Radar, autopilot, Monitor windvane. Reduced \$99,500. Marina Bay. Mike/Jean (510) 672-5820/19.

PEARSON 36-2, 1986. \$79,500. 2004 HaHa vet, outfitted for cruising. Sails, rigging, dodger, bimini, windlass, radar, chartplotter, autopilot, wind and speed, VHF, SSB, solar panels, Force 10 stove, Spectra watermaker, and numerous other upgrades all new since 2002. Berthed in SoCal. (415) 987-6477.



FAST PASSAGE 39. Legendary cruising yacht. Two-time Hawaii, three-time Mexico vet. New engine, prop, dinghy, dodger, genacker. Much much more. \$140,000. For details, email: DRJY2K@aol.com.

ISLANDER 36, 1977. Perkins 4-108, new rigging 2002, 2 self-tailing Harken 44s, 2 self-tailing Barlow 25s. Dodger, covers, holding tank, macerator, propane stove/oven, radar, chartplotter, VHF, bowroller, 2 anchors/chain and rode, carpets/curtains, Avon/ob. Alameda Marina #204. \$55,000/obo. Arnie (415) 999-6751 (cell) or (415) 383-9180 (hm) or email: arnoldgallegos@comcast.net.

BENETEAU FIRST 375, 1986. Let's do the *Time Warp* again. 2004 Boat-of-the-Year. Full race and cruise sail inventory. Comfortable 2-cabin interior. Volvo engine. Raymarine and Garmin electronics. New bottom, upholstery. Lying Seattle. \$69,000. Rocky Horror (206) 772-2662.



HUNTER VISION 36, 1993. Rare-to-market 36 and in excellent condition. Unstayed mast, full batten main, electric main halyard winch, and roller furling jib makes shorthanded Bay sailing easy and fun. Daysail, cruise, or live aboard. Hard dodger, Doyle stackpack, Raymarine color radar/plotter and AP. Refrigerator/freezer, CNG range/oven, pressure water, inverter, VHF, depth, wind, speed/log, electric windlass. 430 hours on 38-hp Yanmar. \$87,500. Call Jim for complete details, photos: (916) 807-0632.

PROFESSIONAL YACHT DELIVERIES

60 years of combined experience, 100,000 miles at sea. Rest assured that **Phil Howe (415) 290-1659** or **Greg Snead (415) 846-6919** will get the job done in a safe, professional manner. Call for details.

WISE MARINE SERVICES

Refrigeration • Air Conditioning • Electrical • Engine Services
Experienced in both Power and Sail systems
Roger Wise • (510) 418-7550 • rdwisesr@gmail.com

VOLPAR, Inc.

(408) 986-0848 • (800) 258-4545
Parts / Service • Penta Only
10am-7pm PST every day including Sat-Sun
email: Volpar@Volpar.com

**VOLVO
PENTA**

OFFSHORE PASSAGEMAKING INSTRUCTION IN THE ATLANTIC

John & Amanda Neal are dedicated to providing hands-on, documented instruction aboard their Hallberg-Rassy 46 *Mahina Tiare III*, drawing on their combined 456,000 miles and 61 years of experience.

www.mahina.com • (360) 378-6131

www.winchmate.com

WINCHMATE SELF TAILING CONVERSION

For Barient & Barlow #27-#32



(415) 460-5151



BUTLER RIGGING 30 years experience

Standing/Running Rigging
Lifelines • Furlers

Grand Prix • Cruisers • Three America's Cups • Star Class

Contact us for a professional quote

(510) 672-2639 • butlerrigging@sbcglobal.net

QUALITY SAILS FOR LESS!

NOW 10%
SEASONAL
DISCOUNT!



SPECIALIZING IN
HIGH QUALITY
CUSTOM FIT
AFFORDABLE
CRUISING SAILS

(510) 769-4858 • leesailsnc@yahoo.com

2021 Alaska Packer Pl. • Grand Marina • Alameda, CA 94501

SAILMAKERS TO THE WORLD!

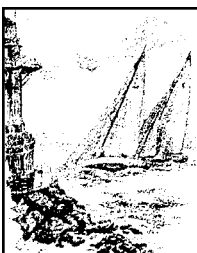

Wm. E. Vaughan

Maritime Attorney, Arbitrator & Mediator

17 Embarcadero Cove, Oakland, CA 94606
Mail: PMB 232 909 Marina Village Pkwy, Alameda, CA 94501

(510) 532-1786 • Fax 532-3461
evstarmr@sbcglobal.net

Avoid Rocks, Shoals, 'Land Sharks' & Confiscatory Taxes

We have resolved marine insurance coverage, damage claims, warranty and lien disputes. Experienced in drafting and negotiating purchase/sale, charter, builder's contracts and dealing with the IRS, State and local tax agencies.

A life-long, Bay, coastal, Delta racer/cruiser as well as an Officer/Director and/or Counsel of Yacht Clubs and other maritime entities since 1954. Affiliate of the Society of Accredited Marine Surveyors (SAMS).

FREYA 39 1978. Ready to cruise. Yanmar with 1,500 hours, Monitor windvane, Profurl, cruising spinnaker, SSB. New: Standing rigging, dodger, radar/chartplotter, Spectra watermaker, fuel tanks and lines, batteries, galley range, cushions recovered. Located in Sausalito. \$80,000. (415) 717-5815.



36-FT STEEL SLOOP/CUTTER, 1964/99. Full keel. Strong, fast sailer. GPS, radio, reefer, windlass, chain, CQR, dodger, newer Yanmar, Avon. Too much to list. Interior rough but functional. \$29,500/obo. Call (360) 385-7588 or email: cliffwds@hotmail.com.

BUCHAN 37 SLOOP, 1965. Westerbeke 30 diesel, Harken furler, Adler-Barbour fridge, water heater, Force 10 stove, depthsounder, good anchoring system. Haulout 4/07. New standing and running rigging. Mexico vet. Priced for quick sale. Google Buchan 37. Asking \$12,900. (650) 773-6327.

CAL 39, 1979. Excellent condition and loaded with new upgrades and extras, list available. Monitor windvane, dodger, bimini. Beautiful clean interior. Great engine and sails. Ready to cruise or sail the Bay. Sausalito slip possible. \$79,000. Call (415) 846-6919 or sailonbaby@gmail.com.



CHUNG HWA MAGELLAN KETCH 36, 1977. In Mexico. Crewing for the Ha-Ha? Meet your boat in Mexico. Located Marina Mazatlan. Proven coastal cruiser, great liveaboard. 2003 masts/rigging, 2001 re-decked/re-cored. Reduced to \$45,000, no reasonable offer refused. More info: (775) 841-0522 or taomin@fastmail.us.

ISLANDER 36, 1973. Fast, stable and fun. New mainsail, headliner, head gasket, starter and upgraded lighting fixtures. Roller furled 140% headsail, self-tailing winches, Perkins 40 diesel, 6'8" headroom and shower. Ready to sail for only \$29,500. For details call (530) 582-8235.



YACHT DELIVERY

Ex-Navy Captain delivering yachts worldwide since 1972
350 ton CG Master • Detailed knowledge Alaska to Panama

Resumé: www.master350.com • (250) 954-0427 • Cell: (250) 951-5201

HARDIN 44 KETCH, 1979 WORLD CRUISER

Fiberglass hull • Wood masts • 5 sails • Roller furling jib
Dinghy • 8-man liferaft • 3 Solar panels • Inverter • Lying La Paz
Complete specs: <www.yachtsus.com> • Make offer

Carl (619) 370-8000 • tracomm@tracomm.com

CATALINA 36, 1986. Ready to go. Below-deck autopilot, radar, electric windlass with gypsy and capstan, 45# anchor with chain rode, refrigeration, propane oven/stove/BBQ, high output alternator, two 8D and one Group 27 battery, inverter, and more. \$55,000. (510) 219-9116.

40 TO 50 FEET

STEPHENS CUSTOM 40, 1982. Sparkman & Stephens center cockpit cutter with 2 staterooms and 2 heads. New 75-hp Yanmar diesel, standing rigging, main, jib, dodger and more. Great condition. Alameda. \$133,000. See website: <www.davishg.org/boat> Call (925) 755-7943 or email: s.v.endless.summer@gmail.com.



BENETEAU 45f5, 1991. Pristine. Never chartered. Elegance, power of Bruce Farr hull lines combined with design beauty of Pininfarina in legendary First Series. Racing around buoys or sailing across oceans, this is your boat. Three cabins, two heads, sloop tall rig, both Kevlar and Dacron sails, deep keel, B&G Network electronics, radar on stern tower, SSB, genset, watermaker, etc. Fully equipped to cruise or race. Located in Santa Barbara. Possible use of 50-ft slip. \$179,000. (805) 692-8856.

WILDERNESS 40. Hull, deck and partial interior needs completion. Deck and hull are Divinycell foam cored. It was hand-laid up by a Santa Cruz fiberglass crew with the highest vinylester/glass ratio possible. It was vacuum bagged and has white gelcoat with stripe. Always warehoused. \$14,000. Call Virgil (916) 687-6254.



47-FT CUSTOM-BUILT CUTTER, 2004. Fiberglass, insulated, 85-hp Perkins diesel, generator, wheelhouse, full keel, new sails, roller furling, radar, autopilot, dual hydraulic steering. Liveaboard, shower, workshop, cruise ready. Well built, low maintenance. Owner's health forces sale. \$625,000. (541) 888-5688. See: <www.hyssop.com/boat/>

LIBERTY 458, 1983. Great layout. Center cockpit. Popular KP 44 hull but built by Passport Yachts to their standards. 85-hp Perkins. RIB with 9.9 ob. Winslow liferaft. Great storage. Beautiful inside and out. Everything you need. Boat is ready to take you around the world. One of the best cruisers around. Located in beautiful Paradise Marina, Nuevo Vallarta. Start your cruising from Mexico and save the sales tax. \$175,000. For specs and photos (619) 727-4554 or Latitude19@mac.com.



TANTON CT44, 1982. Fast, strong, handsome bluewater cruiser. Autoprop, Airmarine, low hour 4-108. Excellent condition. Lying St. Thomas. Great aft cockpit, beautiful two-stateroom interior. Sacrifice at \$79,500. Two-boat owner needs to sell. Email: jackb@surfvl.com.

BEAUTIFUL KETTENBURG 43, 1964. La Paz, Mexico. This fine vessel is in excellent condition. Hauled for regular scheduled paint this week. She is equipped for long range, 11 sails, solar, autopilot, SSB, etc. \$55,000. Call 011 52 (1612) 143-6914 or aeolito@hotmail.com.



CS 40, 1988. Very good condition. One owner. Volvo Penta 43-hp engine. Tony Castro design. Recently overhauled and surveyed. Bottom painted. Fast boat. Excellent for cruising. Available for viewing: Belvedere, CA. Attractively priced, \$72,500. Call (415) 945-9982 or email: mail@telischakco.com.



PETERSON 41, 1982. Built to IOR specifications, later customized to suit the cruiser. Custom teak built-in forward berth, custom dodger. Raytheon radar, Garmin GPS, B&G speed/wind/depth, furling headsail, Maxwell windlass. Motivated 2-boat owner. \$64,900. (805) 689-0504.

PETERSON 44 CENTER COCKPIT cutter, 1977. Two staterooms, two heads. New Yanmar, LP, fuel tanks. Robertson autopilot, radar, dinghy, outboard. \$119,000. San Carlos, Mexico. Call or email for complete list and photos. (520) 742-2727 or svubetcha@aol.com.



AMERICAN MARINE MOTORSAILER. 44'. Large windows amidship offer light, air and views in the galley and salon. With spacious cabins fore and aft, she is a class, comfortable liveboard. New sails and steering. Powered by a strong Lehman diesel. Centerboard for shoal draft. Built in Hong Kong in 1964, she is all teak. For sale \$60,000. See: <http://sausalitowanderer.blogspot.com/> Tim Ryan (415) 902-5484.



FORCE 50 PILOTHOUSE KETCH, 1977. 57' overall. New sails, 5 working, 3 cruising. Low hours on 80-hp Lehman. New generator. Inflatable in davits with motor. Mexico, Hawaii vet. Great liveboard or sailing school charter. 3 staterooms, 2 baths, teak interior. \$135,000. (805) 901-7358.



1990 41-FT PILOTHOUSE ROBERT Perry design, built on Lopez Island by Steven Brouwer. Cold-molded hull, 60-hp Isuzu diesel, 8' Avon, 2-hp Honda. Great Northwest cruiser, fast, comfortable, safe. Built by craftsmen, an exquisite example of quality workmanship and planned boat building throughout. Interior focused around raised pilothouse which features inside steering station and settee elevation that permits a 360° panoramic view while seated. Recent survey. Call for specifications and pictures. Bellingham, WA. Delivery possible. By owner. \$180,000. (360) 510-9807.



CAL 2-46 KETCH, \$119,000. Perfect liveboard cruiser. Sleeps 7. Master cabin aft, private v-berth cabin. Two heads. Over 6' headroom, main salon sits 6+, large galley. VHF, SSB, GPS, weatherfax, EPIRB, Perkins 4-236 85 hp. Great condition. Chartplotter, radar, depth, Monitor windvane, Givens liferaft, Mack Pack mainsail cover. Working sails in good condition, new asymmetric spinnaker, 8-hp Zodiac dinghy, 270 gallons fuel, 200 gallons water. Bottom and zincs maintained. Berkeley Marina. Call (510) 333-9936 or keith@sailenchantress.com.



LORD NELSON 41 CUTTER, 1982. Bristol condition. All major systems replaced within last 5 years by current owner. New 3210 Garmin radar and chartplotter. 459 hours on 65-hp Perkins. Max prop, more. Photos available by email. \$173,000. Call (253) 564-0912 or rcreeby@qwest.net.

44-FT KETCH, GLEN L.-DESIGNED kit boat. Price reduced 40%, owner must sell. 14' beam, 3/4" Airex foam/fiberglass sandwich hull completed, bulkheads in place, aluminum spars. 40-hp diesel, fuel tanks, water tanks, prop, shaft, wind, depth, speed, rudder, hydraulic wheel steering, windlass and antenna installed. Four Bariet self-tailing winches, three anchors, 300' chain, blueprints. In water at Discover Bay, CA. Was \$25k/obo. Now \$15,000/obo. (509) 999-8363 or (925) 516-2877 to view.



47-FT BENETEAU 473, 2001 in Paradise. Located in beautiful Ko'Oolina on O'hau. In-mast furling main, electric winch, low engine hours, A/C. Exquisitely maintained. Liveboard possibility. Fractional ownership? Robert Montgomery (808) 489-9563 or cowboyketch@yahoo.com.

CATALINA 42, 1989. 3 cabin, deep keel model. Cruising upgrades include solar panels, watermaker, Garhauer main and jib travelers, ss mast pulpit, cockpit railings, hand rails, dual Racor 500 fuel filter transfer system, water purifier, liferaft, 10' h/b dinghy, 8-hp outboard, EPIRB, cruising spinnaker with sock and much more. New 2004 to date: Full batten main with 3 reefs and Dutchman, standing and running rigging, dodger, bimini, Freedom charger/inverter, ss hot water heater, 2 heads, ICOM M802 SSB, VHF with RAM, Furuno radar, ST6000 autopilot, ST60 instruments, Garmin GPS, batteries, AM/FM/CD, TV, Bose speakers, and many spares. Located Santa Cruz. \$116,500. Call (831) 462-3013 or email: jpneener@sbcglobal.net.



50-FT DEL REY IN PANAMA. Center cockpit, bimini, roller furling, fiberglass deck/hull, full-keel cruiser. Easy sail for couple. Spacious liveboard, large aft cabin, big galley, mega storage. Radar, GPS, EPIRB, VHS, SSB, meters, compass. Great ground tackle, chain, windlass. Watermaker, inverter, solar panels, 6500 generator. Dinghy, 15-hp Suzuki outboard. New Cummins Turbo 135-hp engine, 2007. Lots more. Good condition. Photos: <www.usedboats.com> #1343752. Reduced to \$75,000, consider trade? Call (402) 614-1062 or email: emerada4sale@hotmail.com.



SYDNEY 41. Excellent racer/cruiser with program of continually updating of equipment and sails. Successful racer with Chicago and Bayview Mackinac wins under all rules (ORR, IRC and PHRF). New 2007 Flag Blue Awlgrip hull. New 2007 upholstery. All winches professionally rebuilt and anodized by Harken. New Murray, Burns and Dovell keel 5/05. Elaborate race-ready sail inventory. New diesel, 200 hours, freshwater only. Excellent cruising amenities including Freon refrigerator/freezer, microwave with 1200-watt inverter, pressure wave. Comfortable sleeping with V-berth and private captain's quarters. Priced to sell at \$139,900. Call Dorsey Ruley (312) 951-5322 or email: d_ruley@yahoo.com.

Yacht Repair
Design / Consulting
Custom Interiors
Exterior Joinery



STEVE'S MARINE WOODWORK

60 C Libertyship Way, Sausalito
jonessail@aol.com • (415) 332-2500

Charts, Cruising Guides, Software,
Nav Tools, Flags, and More!



WAYPOINT
LAT: 37° 46.61' N LONG: 122° 15.01' W

www.waypoints.com
(510) 769-1547

Electronic Navigation Specialists
OceanGrafix Charts-on-Demand

CNI MARINE SERVICES
Deliveries • Instruction
Repairs
Licensed & Insured

Mechanical repairs • Electronic installations
Plumbing/Sanitation installs • Electrical repairs
Deliveries • Boating instruction
Visit us at: www.cnimarine.com
Capt. Steve • (925) 639-1713

PACIFIC SEACRAFT 40, 2004 • Bristol Condition

As loaded as they come • Shoal keel • Windlass • Flat screen TV
Chartplotter • Espar diesel • Forced-air heating • A/C system
Nextgen 5.5 generator • Watermaker • Liferaft • \$399,000

CA: (949) 248-7100 or Toll Free: (866) 375-8304

IRON BEAR MARINE CANVAS

Sail Covers ~ Mooring Covers
Bimini Tops ~ Enclosures
Serving Alameda and the East Bay
Custom Fabrication ~ Repair ~ Replication



Call to arrange a quote:
(510) 435-3754
or email:
ironbear_@mac.com
Robert Shashinda, owner

NAUTOR'S SWAN 43, 1969. Palmer Johnson 43, Hull #20. Navtec Airfoil rod. New Perkins 4-108, less than 350 hours. 14 ss Barient/Barlow winches. Vessel needs cosmetic and teak deck work. Many upgrades. Lying Stockton. Best offer. Rick (916) 296-8525 or rjtesq@northcoast.com. Serious inquiries please.

51 FEET & OVER

HUNTER 54, 1981. Cruising ready and fast. Radar, GPS, chartplotter, wind generator, solar, new sails, furling jib, mast steps, king bed, 4 batteries, inverter, autopilot, cutter rigged, 60-hp diesel, dinghy garage, must see. \$85,000. (650) 222-6238.



SKOOKUM 53 KETCH, 1977. Classic schooner-type wheelhouse aft. Rigged for salmon/albacore. 10-ton insulated hold amidships. Fo'castle with 5 bunks, 2nd complete head, washer/dryer. Master stateroom and complete head aft. Perfect for world cruise or adventure charter. Will email photos. Presently lying Fort Bragg, CA. \$239,000. (707) 357-2120.

CLASSICS

1930 CLASSIC SAN FRANCISCO Bay Bird Boat, 30-ft length. Completely rebuilt. Recent haul and survey. Berthed in SF Marina, #411. \$6,000/firm. Don (415) 681-5145 or email: dscameron@earthlink.net.



CLASSIC 75-FT LOA LUTHER TARBOX- designed Chesapeake Bugeye ketch. All fir construction, meticulously maintained. For more details see: <www.sunstarsail.com> Email: sunstarsail@yahoo.com with sunstar in header or call (530) 467-3173.

64-FT GAFF SCHOONER, 1958. Documented, heavy built fir construction, very roomy. LOD 50, beam 14.5, draft 7, strong 4-108. Recent Panama cruise. Sails well in any conditions. Located Sea of Cortez. Ready to go anywhere. Full details: <www.arcticark.us> \$35,000. alaskashow@yahoo.com or 011-52 (1622) 105-6469.

1964 TAHITI KETCH. Cedar on oak, no leaks, no rot, strong Volvo 2001 diesel, windvane, AP, wind gen, solar, diesel heater, VHS, GPS, large sail and ground tackle inventory. Skipper deceased. Must sell. \$4,500/obo. (415) 621-2990 or sail1025@aol.com.

MULTIHULLS

JIM BROWN SEARUNNER 37. Yanmar diesel, new sails, good condition. \$39,000. Must sell asap. (512) 750-5735 or (760) 420-8200.



HERRESHOFF CARIBBEAN 50 center cockpit ketch, 1978. Recently refinished teak interior. 300 gals fuel and water, 14.5-ft beam, 6-ft draft, 115-hp Perkins diesel. A famous, meaningful pedigree and heavy displacement make this a go-anywhere, stable and comfortable vessel, easily handled by a couple. Capacious storage capability. Back from a 5-year, 15,000-mile cruise, she is ready to go again. Lots of extra gear and tools. Only two owners in 29 years. Yes, she is that kind of boat. If you need a home that is a capable little ship, this is the one. Located Eureka, CA. \$209,000. (707) 834-4798.



HUNTER 54, 1983. Cruise equipped, EPIRB, raft, dinghy with outboard, windlass, furling jib, watermaker, fridge/freezer, radar, VHF/RAM, SSB. 2006 survey. Much more. Located La Paz, BCS, Mexico. \$105,000. Ron Rowley (801) 870-7110 or fax (801) 924-3400 or email: ronrowley@earthlink.net.

AMEL MANGO 53. Totally upgraded and re-fit in New Zealand. Absolutely cruise equipped and cruise ready. Only 2 owners in 24 years. Currently in Brisbane, AUS, soon to leave for New Caledonia, will be in New Zealand by January. It may take awhile for us to get back to you. \$260,000. Call 011-61 (41) 511-7380 or svtojours@hotmail.com.

*** PERSONAL BOATING INSTRUCTION AND DELIVERIES ***

Your Vessel or Mine • Instruction & Local Knowledge • Sail or Power Boat Deliveries • 100 Ton Lic. • ASA Cert. Instructor • 35 Years on the Bay
(650) 380-5535

SMALL AD, SMALL PRICES • RIGGING ONLY

Standing and running rigging, life lines, furling gear, winches, line, windlasses, travelers, wire and terminals, blocks, vang, etc. Problem solving is our specialty. We are a rigging shop specializing in discount mail order. Free catalog.
www.riggingonly.com • (508) 992-0434 • email: sail@riggingonly.com

Ultra Swivel

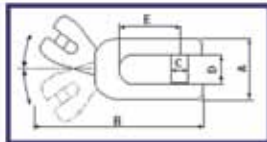

- Connects chain to anchor • Easy passage of anchor over bow roller — WILL NOT BIND!
- Stainless steel swivel rotates 30 degrees before set anchor position is impacted
- Available in 5 different size to fit all chain sizes from 1/4 to 3/4 inch.



Quickline USA — Marine Products from the World, for the USA
15551 Computer Lane #A, Huntington Beach, CA 92649
Phone: 714-843-6964, Fax: 714-843-6906
www.quickline.us or info@quickline.us

USED SAILS

SAIL EXCHANGE

- Largest inventory
- Pay cash for surplus
- Over 20 years in business
- Inspected, rated and offered with no risk, money-back guarantee

www.sailexchange.com
(800) 628-8152

weatherguy.com

Defense Applications and Marine Forecast Service

Rick Shema

970 N. Kalaheo Ave • Suite C-104 • Kailua, Hawaii 96734

Toll Free: (866) 882-WXGY (9949)

Mobile: (808) 291-WXGY

email: rick@weatherguy.com

Office: (808) 254-2525

website: www.weatherguy.com

Fax: (808) 254-1525

FIBERGLASS CATAMARAN, 20' X 10'. Piver design. Fishing or sailboat, day-sailer. 5-hp outboard. Unsinkable. Good condition but needs TLC. Excellent trailer. Carl_F_Anderson@yahoo.com.



26-FT CATAMARAN, 2000. 26' x 15'. Core cell construction, open solid bridgedeck, 9.9-hp 4-stroke electric start, sleeps 4, bimini with 3-sided enclosure. Located near Rio Vista, CA. Asking \$26,000. (916) 203-8517.



TREMOLINO ARGONAUTA. 1995 Dick Newick-designed trimaran. Length 27'. Beam 20'. 8-hp Honda. Sleeps three with two forward and one main cabin, full galley, 26-gal. water tank. Includes trailer. \$33,500/obo. Call Bill (707) 443-4751 or dnm1@humboldt.edu.

BEAUTIFUL VICTORY 35 CATAMARAN. The roomiest and nicest 35' catamaran. Bluewater veteran, comfortable, fully loaded for ocean cruising. Includes watermaker, GPS, autopilot, radar, 3 staterooms, huge salon and galley, much more. See: <www.victory35.com> \$185,000. (408) 218-1518 or seafarer@gmail.com.

1991 CORSAIR F-27, #291 with trailer and new AirDock, still in crate. Pineapples at both ends, plus spinnaker. Lying Honolulu. Take possession in Hawaii with 4.25% sales tax. Email for complete specs and photos. Boat and trailer \$49,000. AirDock \$4,000. (808) 674-0701 or jdbrown@hawaii.rr.com.



1977 CATAMARAN FOR SALE with two 9.8 Tohatsu motors. Less than 12 hours use. Needs minor work. Make offer. (831) 423-5278 (hm) or (831) 212-2462 (cell).

LAGOON 410-S2, 2003 catamaran in excellent sailaway condition. Original owner. 4 cabins, 3 heads, extra-large owner-version head and shower. Low hours. Raymarine depth, speed, wind, autopilot. Radar, inverter/charger, fridge, freezer, full bimini, cockpit cushions, propane BBQ, 12-ft RIB with 2005 15-hp Yamaha, davits, 12-volt generator, upgraded alternators and house battery system in 2006, many spare parts and much more. Located in Caribbean. \$309,000. (415) 883-0407 or sailmonkeys@hotmail.com.



CROSS 40 TRIMARAN. WEST System, Yanmar 35, custom dodger, Cross keel, Forespar cutter rig, good looking, comfortable and safe. \$62,000. View at: <http://picasaweb.google.com/hanahou2007> Email: hanahou2007@gmail.com or (503) 543-9710.



CUSTOM 60-FT CAT, 1999. Fast, long, light, world cruiser or term charter. Four queen-sized cabins with heads and showers, two crew cabins. Epoxy honeycomb vacbag post-cured hulls. Large cockpit with hard top, fridge, twin helms. Calvert Vectran main, jib and screecher, Yankars, Harken/Antal hardware. For info: <www.charterbossanova.com> In Florida. \$795,000. Email: nlbolde@yahoo.com or call Tim (727) 842-7312. We are back from Caribbean and Panama.

POWER & HOUSEBOATS

SILVERTON 38 EXPRESS, 1994. Less than 370 hours on twin Crusader 502s. Meticulously maintained, looks brand new. Many upgrades: Hard top and molded fiberglass extended swim platform. \$99,000/obo. (415) 786-2678.

TRADE OR SALE OR DONATE: 1974 68-ft x 20-ft working steel trawler/office/home. 1,200 sq.ft. of space. Legal live-aboard. Trade value: 45 to 70-ft sailboat or cash or terms. Be creative. Berkeley slip. See: <www.myclassicboats.com> Email: GaryKjennings@msn.com or call (510) 665-7716.



32-FT CLASSIC MONTEREY. Totally restored Monterey fishing boat, converted to day boat, sportfisher or Bay cruiser. All woodwork has been done. New fuel tanks, hydraulic steering, tinted glass, etc. GMC 2-71 diesel engine. Needs to be finished, such as controls, wiring, exhaust and finishing touches. Must be seen to be appreciated. \$45,000, will consider any reasonable offer. Pics/details: (707) 964-5423 or ancona@mcn.org.



65-FT WOOD CLASSIC, 1939. Heavy built ex-trawler. GMC 12V-71, 21-kw generator. Full electronics. Lots of equipment. Ready to go. Would make great conversion. More pics/details: ancona@mcn.org. Asking \$112,000 or any reasonable offer. Call (707) 964-5423.



30-FT WILLARD VEGA SEARCHER. Excellent little ship for 2, good for 4. Super condition in/out. All systems in excellent condition. Full electronics. All safety gear, full head, 100 gals fuel, 100 gals water. See to appreciate. \$46,000. Call (650) 207-6898 or (650) 851-3402.



1984 CHB 34 with single Perkins 135 and lots of extras. Great shape. Downtown Sausalito slip. See specs at website: <www.manukai.com> \$69,500. (415) 272-5056.



ALBIN 25 DELUXE. Swedish pocket cruiser. Sleeps 4 in two separate cabins. Volvo diesel with low hours. Custom-built trailer, custom canvas, many upgrades. Well maintained boat, ready to cruise. \$26,000. Call (415) 331-8209 or (415) 332-1903.



CHRIS CRAFT 33 FUTURA, 1955. Repowered 1995 twin 327 Crusaders, 20 hours. West Marine air conditioning. Excellent condition, new interior 9/2006. Survey. Located Delta. A rare find. \$24,988. (916) 580-7448. Pictures on request: steverobinson@bigvalley.net.



CHRIS CRAFT 28 CATALINA EXPRESS cruiser, 1977. Great family boat. Sleeps 6, VHF, depth, windlass, 6'5" headroom, repowered with 80+ hours. Berthed at Vallejo Marina. Must sell. \$10,000 \$8,000/obo. (707) 486-9647.



58-FT CALIFORNIAN COCKPIT motor-yacht. Must sell, with slip near Long Beach, SoCal. 3208 Cats, 1,600 hours. 16kw generator, 2,000 hours. 2 new Furuno mod 1934 elect. 3 bed, 3 bath, 1,500-sq.ft. of living space, D/W, W/D, 5 flat screen TVs. Includes: 11' dinghy, 9.9-hp Honda, 2 Yamaha WaveRunners and lots more. Only \$275,000/obo and possible carry paper. Van (559) 799-9959 or email: gogetvan@hotmail.com.

MARINE ENGINE CO.

Complete Engine Services • Gas & Diesel
30 Years Experience • Reasonable Rates
Tune-Ups • Oil Changes • Engine Rebuilding, etc.
(415) 332-0455

Specialists in Marine SSB
radio and HF E-Mail

ICOM Marine Radios, Furuno,
SCS/Pactor, McMurdo EPIRBs



HF RADIO ON BOARD

Communication is our Business!

www.hfradio.com
(510) 814-8888

Jack D. Scullion Yacht Services

jdsyachts@att.net
(510) 919-0001

Rigging
Electronics
Troubleshooting
Electrical Installations

COMPLETE MARINE WOODWORK

Design / Restoration • Expert European Craftsmanship • Interior / Exterior
Repairs / Maintenance • Marine Windows & Frame Replacement
Wood & Dry Rot Repairs • Varnish Work • Marine Painting
References Available • Reasonable Rates • Call (415) 331-6718

Y-A-G-E-R

Performance Cruising Sails

Spinnakers • Mains • Headsails

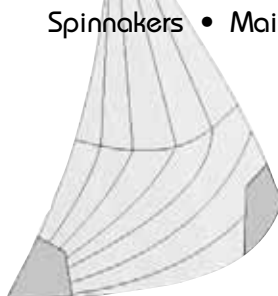

ASK US ABOUT OUR NEW DRIFTER!

- Specially designed for light-air sailing
- Multi-color in 3.9 oz. Dacron or 1.5-2.0 oz. nylon
- Unique sleeve system can be used over furling sail

(509) 928-1964 • www.yagersails.com

ATLANTIC 57 CATAMARAN™



THE ORIGINAL PILOTHOUSE CATAMARAN

- o Designed for easy shorthanded cruising
- o Spectacular windward performance
- o Cored epoxy/glass/carbon construction

CHRIS WHITE DESIGNS
TEL: 508-636-6111
www.chriswhitedesigns.com

MARINERS SCHOOL



www.MarinersSchool.com



Call toll free for more info!
866-SEA-CAPT (866-732-2278)

**Get Your
USCG
Captain's
License
in Just 3
Weekends**

**No Coast
Guard Exam!**

SF Classes Held
at Tradewinds in
Pt. Richmond

Also Offering 100
Gross Ton License
Upgrade Class

Bilge Steam Cleaning Oil Changes

From our boat to yours, we bring the SERVICE to YOU



Fuel Polishing

Tank Cleaning

16-FT MOTOR SKIFF, 2005. Cold-molded cedar with fiberglass/epoxy sheathing. 15-hp Honda, Pacific galvanized trailer, cover. Simple and efficient. Top speed 17 knots, 14 mpg at 7 knots. Excellent condition. Pictures available. \$18,500. John (510) 366-1476.



SOUTH OF THE BORDER

PARTNERSHIPS

CATALINA 380, 2001. Berthed at Sausalito Yacht Harbor. Full electronics, chartplotter, autopilot, and radar. Furling main and jib, cruising chute, Yanmar 40 with low hours, new dodger, electric windlass. Equipped for sailing and cruising: 2 cabins, centerline berths, innerspring mattresses, refrigerator, microwave, flat screen HDTV/DVD, electric head, and separate shower. Berthed in Sausalito. \$23,500. Please call (415) 388-2582 or (415) 717-3825.

1/2 SHARE PARTNER SOUGHT for 1980 34-ft International One Design by Doug Peterson. Built by Jeremy Rogers, Contessa Yachts. Beautiful, well built, fast racing/cruising sloop with many recent upgrades. New rod rigging, Lewmar 55 STs, low-time Yanmar with folding 3-blade prop. Much more. Boat (and owner) in excellent condition. Berthed in Sausalito. \$23,500. Please call (415) 388-2582 or (415) 717-3825.



MORGAN 384 SLOOP, 1984. (Sister-ship pictured). Perkins 4-108, beautiful upgraded interior, newer instrumentation, gennaker, refrigeration, inverter, GPS, new bottom paint, fresh survey. 1/2 \$30,000 or 1/3 \$22,000 partnerships. If you are looking to go south this winter, call. I have two weeks I can go, the rest is yours. Bay Area/Delta base rest of year preferred. Peter (925) 788-9010.

CATALINA 30 SHARE. Best Sausalito slip with package, 5 min. to Bay, 30 min. to Angel Island. Walk to bars/restaurants. Many upgrades plus wheel, diesel. Parking included. Now to May, \$270/mo. Up to 7 days/mo. Non-equity use, renewal opt 7/08. Call (415) 332-5442 or email: Leeloves2sail@hotmail.com.



MARINA RESIDENCE: Condo for rent overlooking Paradise Village Marina located on Banderas Bay near Puerto Vallarta. 1 bedroom, 1 bath. Marina view, watch the boats from your patio. Many amenities. For resort information and location call (916) 367-6292 or email: HNDJohn@starstream.net.

HOGIN SAILS MEXICO. BOB HOGIN will be open in Barra de Navidad, Jalisco, Mexico, from October through June. All types of sail repairs, recuts, and rebuilds. New or replacement roller furler covers and limited cover repairs. Some hardware, snaps, hanks, slides, etc. Astrup sunbrella available. Email: bhogin@hotmail.com or hogin@aol.com. 104 Calle San Pedro, 1 block from Capitania de Puerto office. Call in Barra: (315) 355-8390. I monitor Cruiser's Net in season and can meet you at dock to pick up sails. Turnaround time for repairs, a few days.

LEARN TO SAIL in the Sea of Cortez. San Carlos Sailing School, an ASA school based in San Carlos, Sonora. Specializing in learn-to-sail cruises, vacations. Also offer boat rentals, day trips. See: <<http://mexicosailing.com>> or please call (800) 874-4830.

MARINA RESIDENCE AT PARADISE Village Marina. Top-floor unit, 2 bedroom, 2 bath with Jacuzzi in master bath. \$700-\$900/week, \$1,200/holiday week or buy it for \$315,000. Beach and gym access available. Call (775) 853-0634 or email: tomwro@sbcglobal.net.

CONDO RENTALS NEAR VALLARTA yacht club. Two adjacent condos overlooking Paradise Village Marina. Each 2 br, 2 bath with Jacuzzi, pool and amenities. Access to Sports & Beach Club. Rent one or both. Call (925) 208-1601 or 011-52 (322) 297-7559 or nancymoore1@aol.com.

PLAN YOUR MEXICAN GETAWAY NOW at the brand-new, gorgeous Cielo Y Mar condos. Located in Punta Mita, 35 minutes from Puerto Vallarta, available to rent from private owner. Right on the beach, 10 feet from the water, they offer spectacular views of ocean and mountains, the biggest infinity pool in the area, an endless beach, great advanced and beginning surf breaks, great fishing, tremendous views of whales, bird life and the islands. While uncrowded and tranquil, it's just a five-minute walk to several waterfront restaurants. Choose from a spacious and beautifully furnished one or three-bedroom unit, or an amazing two-story penthouse with lovely shade trellis on the top floor. See details: <www.puntamitabeachfrontcondos.com> To reserve, call (415) 599-5012.

ADVENTURE SAILING TRIPS

Baja Ha-Ha • Mexico • Hawaii
(707) 953-0434

www.adventuresailingtrips.com



THE BRITISH MARINE COMPANY

Quality Service in San Diego
Engine service • Sanitation • FW systems • All onboard electrical systems
Local references • Baja Ha-Ha veteran • Last fix before Mexico

Graham Johnson (619) 822-7087 • angloam2@yahoo.com

TRADE

TRADE LAKE AND SHASTA COUNTY real estate for large sailboat. Single family to 7-unit properties, no bank or credit needed, seller will finance. Great positive cash flow opportunity. Seller retiring. Call Pete (707) 486-5242.

TRADE OR SALE OR DONATE: 1974 68-ft x 20-ft working steel trawler/office/home. 1,200 sq.ft. of space. Legal live-aboard. Trade value: 45 to 70-ft sailboat or cash or terms. Be creative. Berkeley slip. See: <www.myclassicboats.com> Email: GaryKJennings@msn.com or call (510) 665-7716.

WANTED

DO YOU HAVE BIG, OLDER, beamy 40'+ sailboat that's just lying around and not having enough fun? Fixer-upper is OK. Looking for a boat to put into legal, insured charter use in Mazatlan. Partnership, lease-option or some kind of creative deal. No fuddy-duddies, worry-warts, or uptight conservatives. Reply only if you are in the mood for some adventure. David (707) 441-1285 or sailmexico@yahoo.com.

TRAILERS

TANDEM-AXLE SAILBOAT TRAILER. Custom-built in 2000. 12,000-lb capacity. Surge brakes. Tongue extension. Fully adjustable. Fits 20 to 30-ft, full or fin keel sailboat. Used to be the home of a Bayfield 25. Asking \$3,500. Call (707) 764-3536.

GEAR

15-HP SUZUKI OUTBOARD, longshaft, 2-stroke, Lake Tahoe sailboat auxiliary for 30 total hours, excellent condition. Manual first-pull start, external fuel tank and new fuel line. Motor is in Reno available for demo. Price: \$980. Email: jpmrac@yahoo.com.

FORD LEHMAN 120 PARTS. Alternator, Prestolite electric 8MR2091KSS, 2 oil/trans coolers 29155 CNZ and 29133 CNZ. 5 Fram C1191A fuel filters plus new Rule bilgepump, MDL 14A 3700 GPH. ICOM-White remote Commander mic HM-127W. Xantraex Ideal regulator 12/24 output module. Newmar HDM-70 battery charger. Fuse 50MV Deltec 500-amp MKB6-03 and ScubaMax mouth piece for hooka. (916) 721-3832 or mvcapella@comcast.net.

BRAND NEW EDSON COMPASS pedestal, white. Includes guard, throttle and clutch controls and teak cap. Cost \$750. Sell for \$350. (707) 964-1436.

IRIDIUM 9505A SATELLITE PHONE. comes with everything, one year old, used twice. Works anywhere in the world. Asking \$800. Ken (530) 386-4130.

9.9-HP 4-STROKE MERCURY, electric start, saildrive, 25" shaft. Never used. Need 15" shaft. \$1,800. Tracy, CA. (209) 836-4931.

SPECTRA VENTURA 150 watermaker, \$4,499. Currently installed in my Swan, it is three years old but has been used less than 200 hours and has always been stored correctly. This is a 12v unit and includes the MPC3000 controller. Email: boatguy@newmorning.info.

MERCEDES 72-HP NANNIDIESEL. A runner, \$400 with spares. Switlik 6-man liferaft, \$1,500. 9-ft Avon hardfloor roll-up, \$600. (415) 272-5056.



EMERGENCY RUDDER SYSTEM for Sabre 452. Easily modified for similar yachts. Sugar scoop stern. Mounts on custom SS brackets and is 7.5-ft long by 1.5-ft wide. Made for 2000 Pac Cup. Never used. \$800/obo. (408) 504-0998 or jimhurst100@hotmail.com.

PLEASE HELP MY TRAINED cockroaches install your diesel A-4 Universal engine replacement. 15-hp Westerbeke, \$2,200. 12-hp YSE Yanmar, \$1,000. 30-hp BMW, \$2,800. All complete diesel units with trannys. All run well and are cheap. (415) 272-5776 or TheCockroachKing@hotmail.com.

CREWSAVER 6-PERSON OFFSHORE liferaft, full record of inspections, \$1,400/obo. Sailrite sewing machine, \$285. New wetsuits, 5mm, 2-piece Mens XL and Womens 12, \$95/each. Racor 200, \$95. donecruising@sailsafely.com or (818) 456-9597.

MAN OVERBOARD MODULE. Anchors, ropes, 4 Whale Gusher foot pumps, blipper, ARC RLB-35 EPIRB, engine oil extractor kit. Misc. gear. Call for list and prices. (925) 285-0351.

PROFURL NC32, SUITABLE FOR boat up to 38'. Was unused staysail on larger boat. List, \$2,700. Asking \$850. (415) 461-5902 (before 5pm) or sarian1286@aol.com.

ARIES WINDVANE. New 1978 ex-storage. All fittings complete as shipped from England. Price: \$3,000. You pickup Los Angeles. (310) 306-9471 or windvane78@yahoo.com.

MUIR COUGAR ANCHOR WINDLASS. Horizontal electric windlass with wildcat and drum for both chain and rope rode. Clean, excellent condition, \$1,150. Electric air compressor, 110-volt air compressor, new, unused, \$250. Call (415) 596-4884 for info.

YANMAR 3GM30F. Completely disassembled. Needs top end rebuild. \$1,500/firm. (831) 234-4892.

AIRES/MONITOR WHEEL ADAPTER, Avon, outboards, stainless wheel, Trilite/strobe, headsails, BBQ, Edson pump, Lewmar 40STSS, hatches, Avon mount, Yanmar-3HM spares: starter, alternator, elbow, panel, harness. SSB/Ham, autotuner, Spider antenna, compass, inverter/charger, real Danforths: 20H/35H/60H, Baja filter. brad-low@sbcglobal.net or (415) 497-3731.

TOHATSU 2-STROKE OUTBOARD. 5-hp, 1994, low hours. Includes gas tank. Sacrifice at \$550. (707) 331-2961.

BLACK, ANODIZED BALLENGER double-spreader mast and boom. Masthead rigged with stainless rod, 4 complete halyards, internal halyard control, plus a 50-item parts list. I: 47-ft. J: 15-ft. P: 41.48-ft. E: -11.75. Never used, always stored. \$6,500. Call Virgil (916) 687-6254.



RECKMANN ROLLER FURLING upper swivel R-3 (see photo). Brand new, never used. Fits older model furler. Our cost: \$1,200. Will sell for best offer. Email: fb@severson.com or call (510) 530-7169.

74-FT MAST DESIGNED for catamaran. Best offer. (415) 269-5165.

CLUBS & MEMBERSHIPS

CLUB NAUTIQUE PASSAGE MAKER Couples Membership. Includes all US sailing courses, Basic through Offshore Passagemaking, and charter discounts. Asking \$4,000. Cost would be more than \$6,000 purchased from the club. This membership is transferable. Tim (530) 582-0437.

CLUB NAUTIQUE SINGLE Passage-Maker Membership. Includes US SAILING certification classes and training through Offshore Passage Making, free use of trainer (subject to nominal turn-around charge) and free refresher training. \$3,000/obo. Kevin (925) 451-9976.

SINGLE SAILORS ASSOCIATION welcomes all levels of experience. Members enjoy daysailing, cruising, group sails, socials, etc. Monthly meetings 2nd Thursday of month, social 6:30 p.m., meeting 7:30 p.m., Oakland Yacht Club, 1101 Pacific Marina, Alameda. Guests welcome, PICYA member. Call (510) 273-9763. <www.singlesailors.org>

MISCELLANEOUS

CAPTAIN'S LICENSE CLASSES. OUPV (6-pack)/100-ton Masters, plus towing and sailing endorsements. USCG-approved courses. Successful completion satisfies USCG exam requirements. Offered by US Maritime Academy of California. Week-night classes in San Mateo and Ventura. Call Mike (650) 298-9489.

NON-PROFIT

MARIN POWER & SAIL SQUADRON offers members free classes ranging from Seamanship to Celestial Navigation plus cruises and social events. Next Squadron Boating Course in Novato January 8, 10, 15, 17, 22, 24, 2008, all from 7 to 9 pm. Textbook \$35. For details and registration call (415) 883-6777.

FREE BOATING CLASS. 'How to Use Charts', 1 Lesson, Tuesday October 23, 2007, offered by Santa Clara Power Squadron, Sail and Power Boating. Cost for materials only. Call DeWayn (408) 225-6097 for map or to register online go to: <http://www.usps.org/localusps/santaclara/PE.htm>

SAN FRANCISCO SAIL AND POWER Squadron Boating Safety Course starts Oct. 4, 2007 for 7 consecutive Thursdays, 7:30 pm to 9:30 pm at the Oyster Point Yacht Club, South San Francisco. Learn about: Boat Handling and Seamanship, Needed Equipment, Rules of the Road, Lines and Knots, Charts and Aids to Navigation, and much more. Call Janis (650) 871-4447 or email: info@sfps.org.

PROPERTY SALE/RENT

BEAUTIFUL OCEANFRONT CONDO at entrance to Paradise Village and Nuevo Marinas. Corner unit, spectacular view overlooking Banderas Bay. Completely furnished, designer kitchen, 2 bedrooms, 2 bathrooms, satellite TV, indoor parking, extra storage. For sale by owner. Call (650) 906-0461 for info and photos.



SEGWAY OF OAKLAND

212 International Blvd., Oakland • Rent, buy, or lease
All models in stock • New & Used • Only \$35 for a lesson
(510) 832-2429

BLUE PELICAN MARINE

A sailor's consignment store now open at Grand Marina, Alameda
Sails • Winches • Instruments • Brass • Collectibles • Sailing Books
Charts • Small Outboards • Hardware • No large items • No junk
(510) 769-4858 • bluepelicanmarine@sbcglobal.net

CHARMING SEASIDE RETREAT • \$799,000

Fabulous views of Ballena Bay Marina, SF Bay, San Francisco
Sunset Mag Award Design • Vaulted Ceilings • 3 Bdrms • Eat-in Kitchen
Over 2,100 sq.ft. • Views from every room • Immaculate inside & out!
(510) 814-4824 • dvinall@hbrhomes.com

N.E. MARINE TITLE

Coast Guard documentation • Title/lien searches • Transfers • Mortgage filing • Escrow services
Local closing facility for brokers or private transactions
30 years experience of doing it right the first time
1150 Ballena Blvd, Alameda, CA • (510) 521-4925

FAST SHIPPING!

NEW AND USED SAILS!

Specializing in production stocks and featuring the largest selection of stock sails available anywhere! Save with warehouse volume discounts on Stock Sails, Custom Sails, Sail Covers, Furlers and Accessories. All top Quality.

All Fully Guaranteed!

- Full Batten Mains
- Furling Genoa's
- Storm Jibs
- Trysails
- Furling Units
- Custom Canvas
- Used Sails

FREE CATALOG!!

THE SAIL WAREHOUSE

Ph. (831) 646-5346 www.thesailwarehouse.com

WEDLOCK, RAMSAY & WHITING

Marine Surveyors

Pre-purchase, insurance: vessel, engine, rig surveys

Serving the Bay Area since 1980

www.wedlockandstone.com

(415) 505-3494

Monterey Bay Marine

at Santa Cruz Harbor

SeaSport • Scout Boats • Livingston

Pacific & EZ Loader Trailers

Yamaha • Honda • Volvo/Penta

www.montereybaymarine.com **831.479.4595**

OFFSHORE INSURANCE

For U.S., International, & Canadian Registered Vessels... Policy Underwritten through Lloyds, London Underwriters

Apply Online www.DolphinInsurance.com

Ground Floor Seabus Terminal
Tel: (604) 261-9200 Fax (604) 484-2311
#20-801 W. Cordova Street, Vancouver, BC V6B 1G1

Call Toll Free 1-800-460-0619

Dolphin
INSURANCE SERVICES INC. www.dolphininsurance.com e-mail: info@dolphininsurance.com

BERTHS & SLIPS

36-FOOT SLIP TO SUBLET AT scenic Treasure Island. Upwind slip for sublet from mid-October 2007 to April 2008. Rent is about \$300 per month. Sorry, no living aboard. Email: rchrmdm@earthlink.net.

CREW

CREW WANTED. Woman skipper with small classic woodie (Bear) needs women and men with sense of humor for Chowder races, Berkeley. Margie: barongcat@yahoo.com.

MYWAY, LUXURY 70-FT SAILING CAT, needs crew late October to sail from Panama to the Grenadines. Duties: watchkeeping, light cleaning and maintenance plus thorough cleanup upon arrival. Sense of humor, positive demeanor and attention to detail are more important than extensive sailing resumé; some coastal cruising or offshore sailing experience is necessary. Crew to pay travel to and from MyWay, all other expenses covered. Please see www.fastcharters.com for information on crew and boat. Email replies to: mikekopman@mac.com.

WANTED: SINGLE SKIPPER(S). We have crew, but need more skippers. Come to next monthly meeting of Single Sailors Association to meet new crew. 2nd Thursday of month. Social 6:30 pm. Meeting 7:30 pm. Oakland Yacht Club, 1101 Pacific Marina, Alameda. (510) 273-9763. www.singlesailors.org

IF YOU LIKE PIÑA COLADAS, wind in the main, if you're into sailboats, and the taste of champagne. If you've dreamed of cruising warm waters with a fun, cute mermaid you could take, I'm the lady you're looking for, write to me to plan our escape: sailawaymermaid@yahoo.com. (Please be in shape and under 60 years old.)

WOMAN FRIEND, SAILING companion needed. South Pacific tour. When interested, woman should know: Serious ocean sailing, seaworthy yacht, important. Skipper's pleasure: Custom, heavy-duty, bluewater Nordic double-ender, power, comforts, bristol. Custom means seaworthy. Skipper: Eclectic, eccentric, began yachting in diapers, got photos, Sea Scout, owned/built yachts, eyes blue, hair brown, early senior, mutt, medium build, 5'7", part Swede, healthy, able, attractive, sensitive, tennisdance, books, swimfishing, nootrition, eksercise, music. Open to woman friend, child-bearing years OK, soundmind, body spirit. Skipper with yacht. Address for replies only, write to: Skipper Douglas, 414 W. Washington Ave, El Cajon, CA, 92020. Don't disturb tenant. Answer all, write again. Aloha. Thank you.

PROFESSIONAL, EXPERIENCED Stewardess and Mate wanted for traveling motor yacht. US citizens. Send resume to: beamer88@netzero.com.

EXPERIENCED MALE CREW person or delivery captain wanted to help sail well-equipped 36' sailboat from San Francisco to San Diego mid-October. Must have ocean cruising and West Coast experience. Will cover expenses/costs. Email: rchrmdm@earthlink.net.

JOBS WANTED

WANTED: INTERESTING JOB(S). Been flying 100k+ miles per year for 2 decades. Seeking change. Highly skilled with computers, software, contracts, negotiations, analysis, marketing, sales and getting results. Familiar with retail, wholesale and distribution environments. Call James (510) 233-1064 or email: sailing_james@yahoo.com.

JOB OPPORTUNITIES

SF BOAT WORKS SEEKS experienced technicians for new marine installations, engine diagnosis/repair/alignment, exhaust, fuel and water systems, shaft and strut alignment, marine plumbing systems, AC and DC electrical systems diagnosis/installation, other full-service work. Comparable wages and benefits. Fax (415) 626-9172, email: sfboatworks@yahoo.com. 835 Terry Francois St., SF, CA, 94158.

QUANTUM SAILS DESIGN GROUP is looking to fill openings for qualified sailmakers. The positions are in our new 23,000-sq-ft. manufacturing facility in Traverse City, MI. Live in a city that is consistently ranked in the top 10% on lists ranking quality of life and living cost. Salary and benefits offered are at the top of industry standards for qualified personnel. Email: tjraig@quantumsails.com

SAILBOAT RIGGER WANTED. Must have prior experience. Excellent salary for the right person. Email resumé to: southbeachriggers@sbcglobal.net or call (415) 331-3400.

FIBERGLASS REPAIR WANTED. Looking for a person to bid on fiberglass repair on a 38-ft sailboat. Some laminating, mostly fairing. All materials supplied. Bid/estimate, job is ready. Paul (510) 508-0151 or pfetherston@sbcglobal.net.

SAILING INSTRUCTORS WANTED at an award-winning boating club in Sausalito, Richmond and Alameda. Great opportunity to advance your own sailing, power boating and instructional abilities and have fun. For more information call Gary Walker (510) 865-4700 or email: gwalker@clubnautique.net.

Let Your Boat Make Money • Charter It
NEW and HUGE TAX BENEFITS
www.spinnaker-sailing.com
Spinnaker Sailing • South Beach Harbor, SF • (415) 543-7333

Classy Idea! www.latitude38.com

Place your Classified Ad on our Website with your credit card. Fast, easy, convenient and secure. Deadline is always the 18th at 5pm. Your ad will run in the magazine, then be posted on the Website. Try It!

MARINE ELECTRONICS TECHNICIANS wanted. Busy, growing Bay Area marine electronics firm looking for motivated, experienced marine electronics service and installation pros. Great locations, pay commensurate with experience. Ideal opportunity. Call (831) 475-3383 or (415) 331-3166.

QUANTUM SAILS TORTOLA BVI is looking for a Canvas Manager. Candidate must be experienced, customer-oriented and must be able to manage others. This is an opportunity to come and work in a small island community and join an established team of sailmakers. Great benefits and pay scale and of course a beautiful place to live. If interested please email: kwrigley@quantumsails.com.

BUSINESS OPPORTUNITIES

WYLIECAT IS LOOKING FOR a partner with strengths that complement our design and construction skills. Finance – Marketing – Sales. Please visit three websites: <www.wyliecat.com> and <www.sealifeconservation.org> and <www.hybridfishingboat.org> then call Tom Wylie (925) 376-7338.

NEW TO THE MARKET. Latitude 43 Certified Organic Boat Cleaners is looking for marine retailers and boat yards interested in carrying our revolutionary, environmentally safe products. Ask about free shipping. Please call us: (888) 43LAT43 or email: info@lat43.com or see: <www.lat43.com>

TOO LATE TO CLASSIFY

ERICSON 35, 1973. ZOOM. Blindness forces sale. 1999 OYRA Season Champion boat. 2nd and 3rd in Monterey races. 3rd in Benicia Jazz Cup. Excellent race/performance boat. Rebuilt motor. Legal liveaboard berth, Oakland. \$20,000/obo. Michael (925) 250-0133.



RANGER 33. Smooth Atomic 4, new cushions, haulout, bottom paint. Recently rigged, hydraulic baskstay. Wind, speed, direction. Water depth, temp. log, full bimini enclosure, Dickinson propane heater, Force 10 stove/oven, BBQ, roller-furler genoa, #1 and #2 jibs. (775) 831-1353 or thewinwingroup@gmail.com.

CATALINA 310, 2001. Excellent condition, very clean. 27-hp Universal, only 115 hours. Good sails, furling jib, lazyjack main. New stereo with 4 Bose speakers. Near new condition at 1/2 the price of new one. \$74,000. Alameda, CA. (510) 725-2822.



QUICK ATTACH® SWAGELESS FITTINGS

Three easy steps...
 1. Cut wire straight.
 2. Insert Wire.
 3. Tighten Fitting. Done!
The best on the market!

Available in Eyes, Studs, Jaws, & Turnbuckles
 Wire sizes from 5/32" to 1/2"

Strength, Quality and Dependability... plus a Lifetime Warranty!

Stainless Steel Marine Hardware, Rigging & Fittings at Reasonable Prices.

www.BOSUNSUPPLIES.com
 Or call toll-free for catalog and to order
(888) 433-3484

We care about sail care!

San Francisco Service
 773 Andersen Drive, San Rafael, CA 94901
 T: 415-453-2142 M: 510-333-4644
 Hours: 8-5 M-F, Sat. by appointment
SAIL CARE • SAIL COVERS • YACHT COVERS • FLAGS • CRUISING PRODUCTS

CERTIFIED SAIL CARE

San Francisco Service
 Faster by Design
 www.northsails.com

HAWAII

LONG TERM DRY STORAGE
Clear Customs at our dock

GENTRY'S KONA MARINA
HONOKOHAU HARBOR 156°1'30" W
 19°40'20" N
888-458-7896
 TOLL FREE
 The friendliest boatyard in Hawaii

RPARTS
 REFRIGERATION PARTS SOLUTION

100% INTERNET BASED We carry a complete line of refrigeration parts for maintenance, repair, and upgrades for all brands including Grunert, Glacier Bay, Marine Air, Sea Frost, Adler/Barbour and more. We are also pleased to offer R28+ vacuum insulation panels (independent lab tests) all at Rprices: guaranteed lowest!

www.rparts.com

ADVERTISERS' INDEX

AB Marine 87	Aquatic Protection Agency .. 232	Blue Sky Energy..... 160	Cabrillo Yacht Sales 232	Cruising Yachts..... 227
ABC Yachts 234	Awlgrip..... 105	Blue Water Yacht Insurance. 100	Cal Maritime Academy..... 91	CYOA Yacht Charters..... 191
ABI/Precision Lighting 56	Baja Ha-Ha Sponsors .. 154,155	Bluestorm 163	California Yacht Sales..... 228	Desolation Sound Charters.. 190
Agape Villages..... 25	Baja Naval 162	Bluwater Network..... 226	Call Of The Sea 80	DeWitt Studio 95
Alameda Marina/ Pacific Shops Inc. 20	Ballena Bay Yacht Brokers..... 24	Bo'sun Supplies..... 223	Cass' Marina..... 60	Diesel Fuel Filtering 211
Alameda Prop & Machine... 210	Ballenger Spars 27	Boatguys..... 225	Chula Vista Marina 209	Dimen Marine Financing..... 100
Albatross Yacht Charters 190	Bay Island Yachts 7	Boomkicker/Easystow..... 164	City Yachts 17	Dockwise Yacht Transport..... 57
Almar Marinas 79	Bay Marine Boatworks..... 81	Bottom Siders 224	Clipper Yacht Harbor..... 31	Dolphin Insurance Services Inc. 222
American Battery 224	Bay Marine Diesel..... 191	Boy Scouts San Francisco... 229	Club Nautique..... 32	Downwind Marine 65
Anacortes Yacht Charters.... 190	Bay Propeller 101	Brisbane Marina 18	Coast Marine 29	Doyle Sails..... 53
Anderson's Boat Yard 59	BDI Marine Surveys..... 214	British Marine 24	Conch Charters..... 191	Easom Rigging..... 137
Annapolis Performance Sailing 183	Beneteau..... 51	Brunos Island Resort 26	Cover Craft 97	EM Design 214
	Berkeley Marine Center 77	Butler Rigging 216	Coyote Point Marina 55	Emery Cove Yacht Harbor... 182
	Beta Marine Engines 31	BVI Yacht Charters 227	Cruising Direct Sails 99	

RICHMOND YACHT HARBOR, LTD.

320 West Cutting Blvd. • Richmond, California

Looking for space at Pt. Richmond?

On the Santa Fe Channel, there is flexible marine & light industrial multi-use zoning. Approx. 9,000 sq. ft. building, land – storage, parking and docks. Also, 1,000 sq. ft. free-standing drive-in shop. (Between Bay Marine and KKMI).

(510) 235-1176 • Fax (510) 235-1178



HEAVY DUTY DEEP CYCLE MARINE BATTERIES



Available at the following local marine chandleries and service distributors:

ALAMEDA

- Alameda Prop & Machine
- Fortman Marina Store
- Mariner Boat Works
- Star Marine
- Svendsen's Chandlery
- BENICIA**
- Cruising Seas Services

MARTINEZ

- Diablo Marine
- OAKLAND**
- Golden State Diesel
- Outboard Motor Shop
- OAKLEY**
- Big Break Marina
- RICHMOND**
- Bay Marine

AMERICAN BATTERY • Hayward, CA • (510) 259-1150



Save Your Aft!

Using one of our 1400+ patterns or your own pattern, let our craftsmen create a comfortable, durable, and stylish set of all-weather cushions for your cockpit. Find your custom, closed cell foam cushions at www.bottomsiders.com!

BottomSiders

BottomSiders
2305 Bay Avenue
Hoquiam, WA 98550

Call Toll Free: (800) 438-0633
Email: cushions@bottomsiders.com
Fax: 360-533-4474

MARINE ENGINE CO.

PERKINS • YANMAR • ATOMIC 4 • VOLVO
WESTERBEKE • UNIVERSAL • BETA MARINE



CALL NOW FOR LOW ENGINE QUOTES

- Engine Repowering and Rebuilding
- Engine Sales, Service and Parts
- Complete Marine Engine Service

(415) 332-0455



PRIME FABRICATION

Marine Hardware and Custom Metal Fabrication

- Stainless Anchors - Plow, Fluke, Claw & Ace
- Table Pedestals • Flopper Stoppers
- Helm Seats • Handrails

Ph 949.496.1348
Fax 949.496.1341
www.primefabrication.com
33081 Calle Perfecto, Suite B
San Juan Capistrano CA 92675



Hays Marine Transport

Specializing in oversize boat transport

Servicing 48 States & Mexico

(813) 979-2900



jim@haysmt.net

www.haysmarinetransport.net

ADVERTISER'S INDEX - cont'd

Emeryville Marina 169	Glacier Bay 97	Hogin Sails 78	KKMI - Brokerage..... 67	Marina El Cid..... 208
Essex Credit Corp. 89	Glen Cove Marina 103	Holmes Marine Specialties .. 152	KKMI - Full Service Yard... 38,39	Marina Mazatlan 28
Euro Marine Trading 98	Go Cats..... 186	Hood Sails 63	KTI Systems / Filter Boss 150	Marina Puerto Salina..... 202
Farallone Yacht Sales..... 13	Golden Gate Yacht Sales..... 15	Hotel Coral & Marina..... 211	Landfall Navigation..... 91	Marina Puesta Del Sol 206
Ferreteria Zaragoza 162	Golden State Diesel Marine .214	Hunter Marine 10	Larry R. Mayne Yacht & Ship Broker..... 93	Marina Real 208
Flying Cloud Yachts 21	Grand Marina 2	Hydrovane 95	Larsen Sails/Neil Pryde 50	Marina Riviera Nayarit..... 73
Flying Tiger Yachts 179	GreenBoatStuff.com 102	Interlux Yacht Finishes 45	Lee Sails 216	Marina Village..... 61
Foam Creations 141	H&S Yacht Sales 14	Interphase Technologies 104	List Marine Enterprises 29	Marina Vista Coral..... 204
Footloose Yacht Charters..... 188	Harken 68,69	Iron Bear Marine Canvas..... 218	Loch Lomond Marina 140	Marine Engine Company 224
Forespar 48	Hays Marine Transport 224	J/World 181	Maine Cats 190	Marine Lube 220
Fortman Marina 74	Helms Yacht & Ship Brokers/ Seawind Catamarans 49	Jeanneau America..... 11	Makela Boatworks 225	Marine Outboard Co..... 225
Garhauer Marine..... 75	Helmut's Marine Service 226	JK3 Nautical Enterprises 85	Marina Bay Yacht Harbor ... 180	Mariner's General Insurance . 40
Gentry's Kona Marina 223	Heritage Yacht Sales 230	Kensington Yachts 230	Marina de la Paz..... 214	Mariners School..... 220
Gianola & Sons 27		Kissinger Canvas 99		Maritime Institute..... 145



2007 NISSAN OUTBOARDS

NSF 3.5 AI	3.5 hp 15"	\$962
NSF 8A31	8 hp 15"	\$1,664
NSF 15B21	15 hp 15"	\$2,200

TLDI TWO STROKE ENGINES

NSD 90BEPT02	90 hp 20" fuel injected	\$7,544
NSF 115AEPT02	115 hp 20" fuel injected	\$8,300

Controls & 3-year warranty included. 20% off product and/or labor to veterans.



Now offering 14.5' hand-laid ocean kayaks.

265 Gate 5 Road • Sausalito, CA 94966 (415) 332-8020

Get ready for winter...

OCTOBER HEATING SALE

Webasto and Espar

For details and prices check out our NEW website:

www.boatguys.us

Complete System Specialists

Inverters & Chargers • AC & DC Electrical • Diesel Generators
Solar • Marine Sanitation • VacuFlush® • Plumbing
Watermakers • Heating & Air Conditioning

510-393-9168

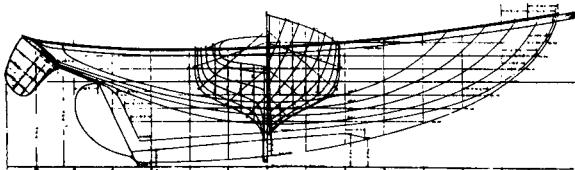

MAKELA BOATWORKS

Family owned since 1948

Wooden Boat Building • Repair and Restoration

19280 South Harbor Drive • Fort Bragg, CA 95437

(707) 964-3963

email: howard@makelaboatworks.com • www.Makelaboatworks.com

Mobile Welding & Metal Fabrication

Aluminum • Stainless • Cast Iron • Steel

We Can Fix It or Make It New!



Bonded • Licensed • Insured

www.mrrpmwelding.net

email: mrrpmwelding@yahoo.com

(650) 455-5229

24-hour emergency

CA Lic. # 876283

WIRELESS E-MAIL



ICOM

SCS
the pacific creators

SEATECH SYSTEMS™

Computerized Navigation & Communication

800.444.2581 • 281.334.1174

info@sea-tech.com www.sea-tech.com

Call for Info on SeaTech Packages & CAPN Demo Disk

Ryan's Marine

Specializing in Marine Electrical Services
for Your Boat

- Electrical system installations from inverters to electronics packages
- Troubleshooting of existing systems
- Dealer for the complete Balmar product line
- Head and holding tank installations



(510) 385-3842

Ryan Schofield
Owner since 1997

email:

rssailor@yahoo.com

ADVERTISER'S INDEX - cont'd

Marotta Yachts..... 233	Nelson Yachts..... 33	Oyster Point Marina 96	Punta Mita Beachfront Condos 168	Sail Warehouse, The 222
Mason Yachts 227	Nelson's Marine 236	Pacific Coast Canvas..... 87 168	Sal's Inflatable Services..... 141
Mazatlan Marine Center/ PV Yachts 28	New Coast Fabrics..... 87	Pacific Coast Yachts..... 228	Pusser's Rum 6	San Carlos Yacht Sales 226
McGinnis Insurance..... 104	New Era Yachts 232	Pacific Yacht Imports..... 9	Quantum Pacific 35	San Francisco Boat Works... 103
McDermot Costa Insurance.. 210	Norpac Yachts 235	Paradise Village..... 165	Quickline 218	San Leandro Marina..... 23
McGrath Yachts 19	North Beach Marine Canvas .89	Passage Yachts 4,5	R-Parts 223	Sausalito Dock-n-Sell..... 231
Milltech Marine Inc. 92	North Sails..... 223	Passage Yachts Brokerage... 229	Raiatea Carenage Services .207	Scanmar International..... 93
Moorings, The 187	North Sails - San Francisco ... 41	Passage Yachts - Racing..... 136	Randall Burg Yacht & Ship 12	Schmidt, Charlotte Yacht Sales 231
Modern Sailing Academy 97	Oakland Yacht Club..... 25	Peter Crane Yacht Sales 231	Richardson Bay Marina 93	Schoonmaker Point Marina . 153
Monterey Bay Marine..... 222	Opequimar Marine Center.. 161	Pier 39 Marina 64	Richmond Yacht Harbor 224	Sea Frost..... 101
Mr. RPM Mobile Welding... 225	Orange Coast College..... 83	Pineapple Sails 3	Rooster Sails..... 89	Seacoast Marine Finance..... 70
Napa Valley Marina 94	Outboard Motor Shop..... 46	Point Loma Publishing 209	Ryan's Marine 225	Seaportal..... 76
Napa Valley Marina Yachts. 228	Owl Harbor 203	Prime Fabrication..... 224	Sail California 34,36,37	Seashine..... 98
	Oyster Cove Marina..... 52	Puerto Lucia..... 205	Sail Exchange..... 218	

info@sancarlosyachts.com
 U.S. Toll Free 1-877-694-4568
 U.S. Fax 1-520-232-2032
 Charlie Bloomer, Marisa Velasco,
 and Joanne Preston.
 Empresas Pahinga S. de R.L. de C.V.

**NEW
 NUMBERS!**



San Carlos Yachts

POWER • SAIL

www.sancarlosyachts.com

On Marina San Carlos and
 the Sea of Cortez, your
Paradise just a few hours
 south of Arizona!

Mountains and desert on the Sea of Cortez. The fastest growing, largest independent boat brokerage South of the Border! All within a few hours' drive of Tucson. **San Carlos Yachts**, has over sixty top-quality cruise equipped sail and power boats available now – and we're adding boats every week.

San Carlos offers easy access WITH NO CAR PERMITS REQUIRED, U.S.-quality boat workers and facilities, certified surveyors, everything you might need. Most everyone here speaks English, too. We can arrange discounted lodging for your stay, dive trips, sportfishing, horseback riding, golf...you name it!

We're only a toll-free phone call away **1-877-694-4568**. Come see why **San Carlos Yachts** is a different kind of brokerage in a different kind of paradise! *¡Se habla ingles tambien!*

SAIL			
26' HUNTER 260 & trailer, 2000.....	27,000	40' HANS CHRISTIAN CHRISTINA cutter, 1986.....	149,900
28' BRISTOL CHANNEL cutter, 1977.....	Pending	40' HARDIN SEA WOLF ketch, 1978.....	59,000
30' CATALINA Mk III sloop, 1993.....	39,000	40' HARDIN SEA WOLF ketch, 1978.....	84,900
32' DOWNEAST cutter, 1980.....	35,000	40' VALIANT cutter, 1978.....	79,500
32' MARINER ketch, 1972.....	35,000	41' C&C sloop, 1989.....	97,500
32' WESTSAIL cutter, 1973.....	49,000	41' CUSTOM CC MOTORSAILER, 1979.....	80,000
33' WAUQUIEZ GLADIATOR sloop, 1982.....	54,900	41' ISLANDER FREEPORT ketch, 1977.....	99,500
34' CATALINA sloop, 1986.....	52,900	42' BROWN SEARUNNER cutter, 1976.....	59,500
34' COAST CUTTER, 1988.....	95,000	42' HUNTER PASSAGE CC sloop, 1990.....	118,500
34' GANLEY SHADOW steel sloop, 1986.....	55,000	42' SPENCER sloop, 1974.....	84,500
34' HANS CHRISTIAN cutter, 1976.....	40,000	42' WHITBY CC cutter, 1977.....	89,500
34' TRUE NORTH cutter, 1976.....	49,900	43' WESTSAIL custom tall rig cutter, 1976.....	115,000
35' CAMPER NICHOLSON sloop, 1974.....	42,900	44' KELLY PETERSON CC cutter, 1978.....	118,900
36' UNION POLARIS cutter, 1977.....	62,500	44' KELLY PETERSON CC cutter, 1977.....	119,000
36' UNION POLARIS cutter, 1978.....	69,500	46' CAL CRUISING 3-46 CC sloop, 1977.....	Pending
37' ISLAND PACKET cutter, 1995.....	159,500	47' HYLAS CC cutter, 1989.....	235,000
38' C&C LANDFALL sloop, 1980.....	159,500	49' LIBERTY CC cutter, 1987.....	240,000
38' CUSTOM HORSTMAN trimaran, 1997.....	149,500	54' CUSTOM SOUTH AFRICAN CC ketch, 1983.....	199,500
38' DOWNEAST cutter sloop, 1977.....	59,000	POWER	
38' ERICSON sloop, 1982.....	59,500	25' GRADY WHITE SAILFISH 255, 1988.....	49,500
40' BENEFAU OCEANIS 40CC sloop, 2000.....	199,950	25' SKIPJACK sport cruiser & trailer, 1987.....	30,000
40' CATALINA 400 sloop, 1995.....	139,000	28' CARVER RIVIERA with trailer, 1984.....	24,500
		28' PURSUIT 2870 EXPRESS, 1996.....	79,500
		28' SKIPJACK SPORT CRUISER & trailer, 1979.....	49,000
		30' BAYLINER 2855 OPEN EXPRESS, 1996.....	33,000
		32' BAYLINER 3218 motoryacht, 1988.....	68,500
		33' FOUNTAIN 33 LIGHTNING EXPRESS, 1989.....	45,000
		34' MAINSHIP PILOT 34 OPEN EXPRESS, 2000.....	125,000
		37' NORDIC TUG trawler, 1999.....	299,000
		37' SEA RAY 370 sedan, 1996.....	135,500
		38' CHB tri-cabin trawler, 1978.....	47,500
		41' HATTERAS convertible, 1986.....	229,500
		41' LITTON flybridge motoryacht, 1978.....	127,000
		41' TIARA OPEN EXPRESS, 1998.....	319,000
		43' MONTEREY sedan convertible, 1983.....	169,500
		43' OCEAN ALEXANDER trawler, 1985.....	169,500
		43' WELLCRAFT PORTOFINO EXPRESS, 1989.....	59,500
		44' TROJAN F-44 motoryacht, 1978.....	150,000
		45' CHB EUROPA sedan, 1982.....	164,900
		45' VIKING sedan convertible, 1989.....	250,000
		47' C&L SEA RANGER trawler, 1979.....	169,500
		50' FERRETTI 150 motoryacht, 1997.....	650,000
		54' KNIGHT & CARVER custom LRC, 1981/2006.....	585,000
		56' SUNSEEKER MANHATTAN, 2002.....	950,000

44' KELLY PETERSON CC CUTTERS, 1977 & 1978. Here are two well equipped examples of this cruising classic. Veterans of the Sea of Cortez, they've been well maintained by thoughtful owners. Now it's your turn to seek distant shores with two to choose from, already located in one of the world's foremost cruising grounds.
From \$118,900!



40' CATALINA 400 SLOOP, 1995. A powerful sail plan, great accommodations, proven quality and innovation...the Catalina 400 has it all. This example has been fully outfitted for cruising, has transited the Canal to the Caribbean and returned to Mexico. Her owners are on to new horizons and want offers on their pride and joy! Plan your trip now to see her! **\$139,000**



43' OCEAN ALEXANDER, 1985. A Pacific Northwest classic! This example is in excellent condition throughout and very well equipped. She's in the water, waiting for you, ready to continue cruising Mexico and beyond.
A must see! And now, an even better value!
\$169,500



Donate your Boat

Cars, Trucks, RVs, & Real Estate
 We handle all DMV & Smog
 Running or NOT (restrictions apply) **Tax Deduction**

BLUEWATER NETWORK | **800-324-7432**

"Proceeds help Bluewater Network reduce greenhouse gases, clean up our air and water, and protect marine mammals and wildlife."

VOLVO PENTA

ENGINES • PARTS • SERVICE

We Ship Anywhere
1-800-326-5135
 (415) 453-1001
 FAX: (415) 453-8460
 www.helmutsmarine.com
 619 Canal Street
 San Rafael, CA 94901

HELMUT'S MARINE SERVICE INC
 AUTHORIZED POWER CENTER

Call us for your nearest Volvo Penta dealer 1-800-326-5135

ADVERTISER'S INDEX - cont'd

Seatech.....	225	Svensden's Metal Works.....	178	Ullman Sails.....	47	Western Grace/ Orca Yacht Charters.....	189
Selden Mast, Inc. USA.....	42	Swedish Marine.....	103	Vallarta Yachts.....	30	Westwind Precision Details..	105
Shadetree Fabric Shelter.....	95	Tall Ship Education Academy.....	102	Vallejo Boat Works.....	141	Whale Point Marine Supply ..	54
Society of Accredited Marine Surveyors/SAMS.....	30	Tartan/C&C Yachts.....	16	Vallejo Marina.....	71	White, Chris Designs.....	220
South Beach Harbor.....	90	The Boatyard at Grand Marina	22	Vaughan, William E.....	216	Winchmate.....	216
South Beach Riggers.....	26	The Mexican Inn.....	164	Ventura Harbor Boatyard....	204	Windpath Sailing, Inc.....	99
Southern California Marine/ A to Z Marine Services.....	66	Tiburon Mist at Paradise Cay. 88		Viking Lifesaving Equipment	151	Wizard Yachts, Ltd.....	230
Spectra Watermakers.....	82	TMM/Tortola Marine Mgmt. 191		Voyager Marine.....	72	Wright Way Designs.....	105
Starbuck Canvas.....	24	Tradewinds Sailing.....	101	weatherguy.com.....	218	Yachfinders/Windseekers....	26
Sunsail Charters.....	44	Trident Funding.....	8	Wedlock, Ramsay & Whiting Marine Surveyors.....	222	Yager Sails.....	220
Svensden's Boat Works.....	43	Twin Rivers Marine Insurance .91		West Coast Yachts.....	86		
Svensden's Marine.....	84	UK-Halsey Sails.....	58	West Marine.....	25,27,29,31		
				West Marine Rigging.....	62		



LOOKING TO BUY A BOAT IN THE BVI?



BENETEAU 50.4, 2007
Brand new boat!
Just Delivered. \$310,000



BENETEAU 473, 2005
Cacafuego. \$239,000



BENETEAU 343, 2005
Nina. \$100,000



BENETEAU 323, 2004
Chablis. \$85,000



BENETEAU 40, 2007
Brand new boat!
December delivery. \$203,000



B.V.I. Yacht Charters
Joma Marina, Tortola, BVI
(284) 494-4289
(888) 615-4006
charters@bviyc.com
www.sailinthebvi.com

yachts in photos may be sisterships

Pre-Cruised Best Buys



**Cruise The
World At
20+ Knots!**

'01 Hunter HC50/53 • \$498,000



**Reduced!
Like New**

'06 Jeanneau 45 • \$299,000



**New Listing
3 Staterooms!**

'07 Hunter 44DS • \$299,950



Sale Pending

'83 C&C Landfall 43 • \$129,999



Like New!

'05 Hunter 41DS • \$219,950



Like New!

'07 Hunter 41DS • \$224,995



'04 Hunter 386 • \$169,995



'05 Hunter 38 • \$199,000

Mason Yachts International Yacht & Ship Brokerage



54' Jeanneau Deck Saloon, 2005
\$625,000 • Marina del Rey
Contact Tom Hugh Jones (310) 577-8070



52' Jeanneau Sun Odyssey, 2000
\$429,000 • San Pedro
Contact Matt Gaskill (310) 577-8070



51' Atlantic Kanter Pilothouse Ketch, 1995
\$169,000 • Steel world cruiser. Fully loaded.
Contact Greg Fuller (415) 847-4716



44' Marine Trader Trawler
\$130,000 • Morro Bay
Contact Rick Rudnick (805) 259-6113



38' Hans Christian, 1980
\$99,000 • So. San Francisco
Contact Bill Hersey (415) 272-8250



32' Tahiti Ketch, 2000
\$44,900 • Steel hull • Ventura
Contact Mark Ean (310) 577-8070

www.MasonYachts.com



'05 Hunter 33 • \$99,995

**Trade-In
Bring Offers!**



'99 Hunter 290 • \$49,900



'05 Hunter 27 • \$59,995

Loaded!

**Want Your
Boat Sold Fast?
Call Us For A
Free Consultation
Today!**



1-888-78-YACHT • www.cruisingyachts.net

Alameda • Monterey

Sisterships may be shown. Subject to prior sale, change or withdrawal without notice.

Great Opportunities Now To Purchase Your Next Yacht!



Whether you're a first-time buyer or an old pro at the yachting game, buying a yacht can be a daunting process. It's an emotional time filled with difficult choices and each decision you make has money riding on it. And this time of year is filled with great values!

I'll show you not only how to make sure you've found the right vessel, but how to negotiate a fair price and enjoy the adventure along the way! In today's complex, fast-paced world, you can't afford to learn these lessons through trial and error. The tips contained in this report will go a long way toward making you a savvy buyer.

NOW is the time to get the best value for your dollar – Call Me! (510) 381-1400



Just call David's 24-hour information hotline (888) 827-1891

24 Essential Tips to Buying Your Next Yacht – x2023

20 Questions to Ask Any Broker Before You Sign a Listing – x2033



Pacific Coast Yachts, Inc.

1853 Embarcadero – 2nd Floor
Oakland, CA 94606

(510) 764-1734

26' Meter Twin Screw Tug....	€750,000 24/7 info x5103
52' Catamaran.....	\$656,849 24/7 info x5183
40' Mainship Trawler	\$299,950 24/7 info x4093
40' Jeanneau DS	\$159,950 24/7 info x3103
33' Hunter.....	\$129,950 24/7 info x3013



COM-PAC 35

The Compac 35 is the yacht without compromise.

Traditional styling, comfortable cruising, quality construction combined with competitive pricing makes the boat a "must see."



(619) 295-9669 • www.californiayachtsales.com

56' FOUNTAINE PAJOT MARQUISES

2001

\$950,000



Most spectacular salon of any yacht in its class. Panoramic views and rich cherry joinery throughout. Large galley complete with bar and built-in seats; wrap-around dinette accommodates 10. Impressive navigation center with all the latest electronics.

Entire starboard hull dedicated to the captain's stateroom. Two large staterooms with their own private heads to port, with additional crew quarters. More than 1,000 sq. ft. of deck space. Low hours on twin Yanmar 75hp direct drive diesel engines.

This vessel will take you anywhere in the world and is only limited by your imagination.



NAPA VALLEY MARINA YACHTS

(866) 363-8882 • (707) 252-8011

'Electronic Latitude
www.latitude38.com

For a **FREE** subscription to *'Electronic Latitude*, send an email to: **LectronicLatitude-on@latitude38.com** with 'subscribe' in the subject line.

Give A Little... Now Accepting Automobiles!

Give A Yacht...

Your generosity will give your boat a new home and give you a nice tax break and great satisfaction...

Our growing Scout program needs your support:

- Any serviceable vessel can be used.
- We'll make the transfer quick and easy.
- Tax benefits from donating can meet and sometimes even exceed the amount realized from selling your vessel.
- You can eliminate the bills associated with the cost of owning your boat.

Donations Are Tax Deductible

Donate Your Boat to the Sea Scouts
San Francisco Bay Area Council,
Boy Scouts of America

For more information contact: **Matt Myers**
1-800-231-7963 x145 • mattm@sfbac.org

FREE BERTHING FOR NEW LISTINGS – CALL

SISTERSHIP	BENETEAU 361, 2003 Loaded. Professionally maintained. Rare SF Marina berth included with boat. \$150,000
	BENETEAU 473, 2002 \$229,000
	BENETEAU 461, 2000 \$199,000
	BENETEAU 343, 2006 \$133,000
	BENETEAU FIRST 36.7, 2002 \$129,000
SISTERSHIP	HUNTER 34, 2001 \$82,500
	CATALINA 30, 1995 1995 ~ \$54,500
	ISLAND PACKET 380 2001 ~ \$243,500
	CATALINA 32 1994 ~ \$59,900
	ISLAND PACKET 420, 2000 \$329,000
SISTERSHIP	ISLAND PACKET 370, 2004 \$309,000

NEW ALAMEDA OFFICE
1070 MARINA VILLAGE PKWY, STE 101
ALAMEDA, CA 94501
(510) 864-3000

PT. RICHMOND OFFICE
1220 BRICKYARD COVE RD.
PT. RICHMOND, CA 94801
(510) 236-2633

www.passageyachts.com
sales@passageyachts.com

HERITAGE

Yacht Sales

Live your Dreams



45' Catalina
Morgan
1991
\$135,000



43' Kettensburg
1965
\$69,500



42' J/Boat
1999
\$239,500

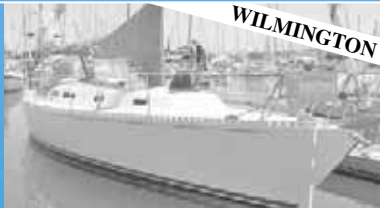

41' C&C
1987
\$109,000



40' Beneteau
Oceanis
1996
\$128,500



37' Cal
1966
\$109,000



Slips available!

Long Beach-Naples 231 North Marina Dr. 866-56-YACHT
Newport Beach 829 Harbor Island Dr. 877-38-YACHT
Wilmington Berth 202 Peninsula Rd. 877-59-YACHT

Full specs at www.heritageyachts.com

GO FASTER

Wizard

YACHTS LTD.

Bill Lee
Dan O'Brien
Tom Carter
Tim Hess



345 Lake Ave., Suite G
Santa Cruz, CA 95062
(831) 476-9639 fax (831) 476-0141
www.fastisfun.com



70' ANDREWS TURBO SLED New engine, carbon mast, two keels, many recent upgrades. **\$299,000**



FRERS 62 Aluminum cruising sloop. Extensive, delightful interior. Forward & aft staterooms, 2 heads, sleeps 10. Shorthanding setup. **\$259,000**



OPEN 50 'Tuesday's Child' Extensive upgrades. Real interior including V-berth. Water ballast. Inboard diesel. **\$115,000**



SANTA CRUZ 50 Go fast and have fun. Recent mast, sails and scoop. **\$179,000**



SANTA CRUZ 40 Set up as a very fast cruiser. Extensive cruising systems were professionally installed. **\$84,900**



CAL 31 Pocket cruiser. Diesel, excellent condition, one year Santa Cruz slip possible. **\$26,900**



Kensington Yachts

"Everyone needs a bigger boat"

UNIQUE, REDUCED COMMISSIONS!!

Our commission structure is on a sliding scale.

- Have a large note?
- Two boat owner?
- Death or family emergency?
- Want to trade up?

We have seen every situation, and understand.

Call us today. Let us help you sell your boat!



BRISTOL 47.7 CC, 1992...\$379,000



43' MORGAN CENTER COCKPIT, 1985...\$122,500



36' S2 CENTER COCKPIT, 1984...\$54,900



34' CANADIAN SAILCRAFT CS, 1990...\$63,000

42' BAVARIA, 2000.....	SOLD	30' CATALINA, 1980.....	\$23,500
41' COOPER 416, 1980.....	Sale Pending \$87,500	POWER	
41' DEFEVER TRI-CABIN, 1977.....	SOLD	40' BAYLINER 4087, 1996.....	\$169,000
37' WAUQUIEZ, 1971, Chance.....	\$49,000	28' BAYLINER TROPHY 2802, 2001.....	Santa Cruz Slip
36' FREEDOM YACHTS SLOOP, 1986.....	SOLD	24' SEA SPORT EXPLORER 2400, 2006.....	SOLD

Kensington Yacht & Ship Brokers

email: yachts@kensingtonyachts.com

877.444.5272 • 415.793.9376

www.kensingtonyachts.com

Sausalito DOCK-n-SELL

Dock your yacht where it will be seen
by buyers in downtown Sausalito.
No brokers/salesmen commissions.
Save thousands!

Complete Yacht Services
Detailing - Electrical - Heads
Surveys - Title Search
Sea Trials - Financing - Comps

'For Sale by Owner' is not a new concept, we just made it easier and more cost-effective. Your yacht will be ready to show 24/7 by appointment with pre-qualified buyers. No more wasting time with tire kickers. Space is limited, so call today for details – you will be pleasantly surprised!

Trailerable Boats Welcome!

COME VISIT US AT OUR NEW **LARGER**
SALES DOCK
at the historic Liberty Ship Marina!

Sausalito DOCK-n-SELL
41 Liberty Ship Way, Sausalito
behind the Bay Model
415.686.6860

CHARLOTTE SCHMIDT

YACHT SALES

When Experience Counts

4100A Harbor Blvd.
Oxnard, CA 93035
Fax (805) 382-2374

In SF Bay Area: (415) 613-0712

(805) 382-2375

Csyachtsales@cs.com

www.yachtworld.com/charlotteschmidt



70' ANDREWS, 1993

Yanmar diesel, inverter, three-cabin layout, new electronics, new wiring, entire refit. A true racer/cruiser. At our docks and ready to be sailed. Priced to sell. Call Charlotte. **\$275,000/offers**



34' PACIFIC SEACRAFT, 1988

Yanmar diesel, low hrs, GPS, autopilot, dodger, furling jib. Must see this special cruiser!! Excellent condition. Please call for appt. **Asking \$114,900**



44' HANS CHRISTIAN PH MS KETCH, 1982
Single diesel, genset, inverter, hand-fitted teak interior, chart plotter, radar, AP, dinghy w/outboard, full keel. In Seattle. **Asking \$289,000**



41' HUNTER 410, 2002

Yanmar diesel, inverter, Raymarine radar, autopilot and wind instruments. Beautiful interior. Must see! **Asking \$159,000**



34' GEMINI 105M CATAMARAN, 1997

Many great features, Westerbeke diesel, autopilot, chartplotter, furling jib, excellent condition! **Asking \$115,000.** Contact owners' listing agent Gary Kaplan at (415) 613-0712.



47' VAGABOND KETCH, 1986

Ford Lehman diesel, genset, chartplotter, radar '06, AP '06, SSB, 12' Avon, dodger. Stunning condition. Top condition. You won't find a better Vagabond. At our docks. **Asking \$249,000**

Peter Crane Yacht Sales and Charters

*In Santa Barbara - experienced, interested, friendly, low pressure
Brokerage without walls*

Peter Crane (805) 963-8000

Mark Scott-Paine (805) 455-7086



1991 Beneteau 45 f 5 Pininfarina
pristine, well equipped, cruise ready
never chartered, **\$175,000**



1978 Holcomb 38' schooner
bronze fastened work of art
handcrafted top to bottom **\$75,000**



1958 Bounty II yawl
well restored, excl. paint, decks
new diesel, good sails **\$45,000**



1992 Gulet 88 motorsailer
beautiful condition, new cat engine
6 cabins ea w/ head, shower + crew
\$900,000



1974 Formosa 51 pilothouse
recent major refit for world cruise
change in plans forces sale **\$138K**



1989 Grand Banks 46
meticulously maintained
375 HP Cats and cruise loaded
\$395,000

Info and photos: www.petercraneyachts.com
pc@petercraneyachts.com
Santa Barbara Slip Specialists, 25' & 51' Slips Available Now

CABRILLO YACHT SALES

"Discover The Difference"

(619) 523-1745

www.cabrilloyachts.com

Sun Harbor Marina (next to Fisherman's Landing)
5060 N. Harbor Drive, Suite #155, San Diego, CA 92106

tayana yachts sales/service



Custom Construction

64' TAYANA, 2008

- 200 hp diesel
- 650 fuel
- Electric windlass/winch
- 3-4 cabins

All New
72' Deck Salon
Bill Dixon design



2008

46' TAYANA PILOTHOUSE
325 gal. fuel, dual stations,
Also a used 3-cabin model



2008

48' TAYANA DECK SALON
Center cockpit or pilothouse models.
Also a used 48', 55' & 46' PH



Tayana

ALL NEW BILL DIXON DESIGNED
54' TAYANA
Check it out.



Used Tayanas

TWO 55' TAYANAS
Ready to take on your wildest cruising dreams.
Plus used 42'.



Pilothouse

50' HUDSON KETCH
The famous Force 50 hull.
3 cabins. Reasonable price.



New to Market

45' DOWNEASTER KETCH
Location: Hawaii. Slip obtainable with
credit check. Make offer today.



Hunters

42' HUNTER PASSAGE
Two available. Center cockpit.
Great local cruiser.



Price Reduced

38' VAGABOND WESTWIND
Many custom features. Super clean,
cruise ready. \$124,900. Also: 42' Tayana CC.



Steel

42' FRANS MAAS
45' Pilothouse and a 46' motorsailer.
Each priced under 100k.



2005

MORGAN/CATALINA 440
"No worries" says it all. Under factory warranty.
Also: 42' Catalina, 2002



Like New

40' BENETEAU
Center cockpit, 2001. Like new condition
with all the whistles and bells.



Recreational

TWO 34' HUNTERS
and a 30' CATALINA.
Great boats for the \$\$.

Worldwide / Mexico / Pacific Coast

Tayana Yachts • Large Selection of Used Yachts

www.cabrilloyachts.com

Mexico Connection Keith Demott (520) 743-7833

NEW ERA yachts

POWER & SAIL



47' VAGABOND, 1981 • \$165,000



REDUCED

38' KAISER, 1971 • \$62,500



36' CHEOY LEE, 1986 • \$59,000



PENDING

35' ERICSON, 1973 • \$20,000



31' HUNTER, 1999 • \$74,500



31' HUNTER, 1987 • \$28,500



48' DEFEVER, 1981 • \$279,000



2 to choose from

42' GRAND BANKS • From \$59,900

Visit our new office in Grand Marina

2021 Alaska Packer Place, Alameda, CA 94501

(510) 523-5988 • www.newerayachts.com

DONATE YOUR BOAT

to the Aquatic Protection Agency.

We protect our precious coastal waters from illegal toxic pollution.

We can use your equipment, so you will get maximum value for your donation.

Call 415-235-0756

or 831-247-8228

boats@aquaticprotection.org

We are on the water, monitoring cruise ships, performing BlueBoater trainings, and testing outfalls for harmful toxins.

www.AquaticProtection.org



w w w . c a b r i l l o y a c h t s . c o m

w w w . c a b r i l l o y a c h t s . c o m



Marotta Yachts of Sausalito

Brokers of Fine Sail and Motor Yachts

415-331-6200 • info@marottayachts.com

NEW LISTING



See at:
www.marottayachts.com

46' WATERLINE CUTTER, 1999 This beautiful steel cruising cutter is well equipped (almost \$100,000 of electronics, as well as genset, central air, electric winches, watermaker, washer/dryer, etc., etc., etc.), highly customized with a \$225,000 refit in '04-'05, and shows bristol inside and out. **\$499,000**



See at:
www.marottayachts.com

47' JEANNEAU SUN ODYSSEY, 1992 Sexy Euro-style performance cruiser w/deep draft kevlar-reinforced hull & nicely laid out, spacious 3-strm inter. Well equipped w/offshore dodger, full suite of electronics, new Doyle sails, heavy duty ground tackle & 10' Caribe RIB on nicely executed stainless steel davit system. **\$230,000**



REDUCED

See at:
www.marottayachts.com

42' CHEOY LEE GOLDEN WAVE, 1984 Designed by Bob Perry to look like a Swan topside and a Valiant 40 below. Never cruised, she shows nicely – sails in fine shape, low time on the trusty Perkins 4-108 diesel, heavy duty stainless steel, dinghy, davits/radar arch, electric windlass, radar, etc. **\$94,000**



See at:
www.marottayachts.com

SISTERSHIP

40' SEAWOLF KETCH, 1973

This is THE nicest Seawolf we've seen in years – repowered, new decks and cabin, hull Awlgrippd, and looks NEW! Also possible Berkeley liveaboard slip. **\$78,000**



See at:
www.marottayachts.com

38' BENETEAU, 1990

Mooring 38 model, designed around a modified First 38s5 hull, a sleek, fast two-stateroom two-head racer/cruiser, perennially popular on the brokerage market. Clean, with a new suite of sails and a rebuilt Yanmar engine. **\$69,500**



See at:
www.marottayachts.com

40' HUNTER LEGEND, 1987

6'5" headroom throughout, QUEEN berth aft, plus a roomy cockpit and well-designed plan topsides – it's a hard-to-beat package (especially at a price well below \$100,000!). Clean, low engine time and transferable Sausalito slip. **\$69,000**



See at:
www.marottayachts.com

36' ISLANDER, 1983

The Islander 36 is one of the most popular 36-ft sailboats ever built, and this particular late-model example is VERY clean inside and out. With \$20,000 spent over the past several years, the boat needs nothing. **\$59,000**



REDUCED

See at:
www.marottayachts.com

36' SWALLOWCRAFT SCYLLA KETCH, 1979

Very nice aft cockpit motorsailer built in Korea to European quality standards. New listing, additional information available soon. **\$54,900**



See at:
www.marottayachts.com

41' PEARSON RHODES SLOOP, 1965

With her East Coast pedigree and lines reminiscent of a classic Hinckley or Alden, she turns heads wherever she goes. With a full keel with cutaway forefoot and updated systems, she sails like a dream on the Bay. **\$53,000**



NEW LISTING

36' C&C SLOOP, 1979

Very clean with much updated equipment, note especially professionally repowered with a Yanmar diesel. Also tastefully redone interior, updated electronics, recent running rigging/roller furler/sails, all brightwork is immaculate, much more. **\$49,500**



REDUCED

See at:
www.marottayachts.com

40 CHEOY LEE OFFSHORE 40, 1968

Ted Brewer said, "No one yacht is perfect, but this Philip Rhodes design comes very close." Always a California boat, this one is in very nice shape and lying in a transferable Sausalito slip. Very well priced and offers encouraged. **\$39,800**



REDUCED

See at:
www.marottayachts.com

35' PEARSON, 1981

Bill Shaw-designed classic in fine shape, just detailed and lying in a transferable Sausalito slip. New listing, full story online at www.marottayachts.com. **\$34,800**

100 BAY STREET • SAUSALITO • CALIFORNIA 94965



**34' HANSE 341
2003**

Bristol condition, gorgeous interior with flatscreen. Cockpit cushions, bimini.

Inquire

Anchorage Brokers & Consultants YACHTS



www.yachtworld.com/anchoragebrokers
#1 Gate 5 Road, Sausalito, CA 94965

(415) 332-7245
yachts@abcyachts.net

25 Third Street,
San Rafael, CA 94901
(415) 457-9772

CLAY & TERESA PRESCOTT • STEVE EMERSON • GEORGE HIGBIE • PHIL HOWE • LARRY MAYNE • DANA PAUL • ARNIE GALLEGOS • PETER BOHN • ED LAbARRE • JOHN SAUL



**PRICE
REDUCED**

PASSPORT 37, 1986 Robert Perry design, second owner, newer sails in 2003, Pullman berth, beautiful teak interior. **\$109,000**



HUNTERS

Pictured: 29.5' HUNTER, 1994
Self-tacking jib. **\$42,500**
33' HUNTER, 2004, loaded. \$90,000



BAL TIC DP 42, 1984
New sails, new rigging, beautiful interior, Sausalito slip. **\$189,000**



**PRICE
REDUCTION**

43' HANS CHRISTIAN KETCH, 1982
New engine. Great deal! **\$155,000**
Also: **38T CUTTER, 1980, \$99,000**



**BAJA HA-HA
READY**

32' FUJI KETCH, 1976 Pristine condition, great affordable cruiser. **\$37,500**
— **MORE BAJA HA-HA UNDER 50k:** —
Westsail 32s - Islander - Challenger

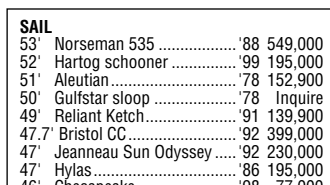

SAIL

53' Norseman 535	88	549,000
52' Hartog schooner	99	195,000
51' Aleutian	78	152,900
50' Gulfstar sloop	78	Inquire
49' Reliant Ketch	91	139,900
47.7' Bristol CC	92	399,000
47' Jeanneau Sun Odyssey	92	230,000
47' Hylas	86	195,000
46' Chesapeake	98	77,000
47' Perry cutter	80	115,000
45' Bruce Roberts CC	79	120,000
44' Hylas	86	185,000
44' Norseman CC	84	230,000
44' Islander	84	109,000
44' Cheoy Lee	81	95,000
43' Swan	86	215,000
43' Hans Christian	82	155,000
42' Baltic DP	84	189,000
41' Sceptre	82	135,000
41' CT	76	79,000
40' Cheoy Lee MS	75	73,900
40' Olson	83	69,500
40' O'Day	86	75,000
40' Hunter 40.5	95	116,000
40' Challenger	73	73,000
39' Fast Passage	78	155,000
39' Cal, nice	79	77,000
39' Freya	81	109,500
38' Kettenburg	Inquire	
38' Ingrid	76 & '84 from	61,900
38' Hans Christian	80	99,000
37' Alberg, equipped	72	90,000
37' Rafiki, new engine '07	77	67,000
37' Irwin	79	40,000
36' Islander Freeport	82	Inquire
36' Catalina	'84 & '93 from	59,500
36' Sweden	84	75,000
35' Beneteau Oceanis 350	88	75,000
35' Baba	79	77,500
35' Ericson, nice	79	33,000
34' Hanse 341	03	Inquire
34' C&C	80	37,500
34' Sabre	83	49,000
34' J/105	'95 & '99 from	105,000
33' Mason	87	114,500
33' Newport	84	34,500
32' Westsail	'77 & '78 from	42,000
32' Fuji ketch	76	37,500
32' Challenger	78	31,500
31' Pacific Seacraft Mariah	79	69,000
30' Catalina, new engine	75	16,500

30' Islander	75	15,000
30' Lancer	80	36,000
30' Hunter	90	36,000
29' Hunter 29.5	94	42,500
28' Newport	79	9,500
28' Pearson Triton	61	11,000
27' Pacific Seacraft	80	59,500
14' Whitehall, sail/row	02	11,000
12' Beetle Cat, wood		9,975



47' JEANNEAU SUN ODYSSEY, 1992 3 state-rooms, master is Pullman, upgraded beautiful interior, RF main, 75hp Yanmar. Worth seeing! **\$230,000**



41' SCEPTRE, 1982
Inside helm, raised saloon.
\$135,000

POWER

67' Stephens Alum	80	895,000
65' Pacemaker, cert.	71	299,000
65' Elco Classic MY	26	450,000
61' Stephens	66	250,000
58' Hatteras TCMY	73	330,000
58' Hatteras MY	73	244,000
57' Chris Craft	65	119,000
53' Hatteras MY, new engine	76	259,000
50' Stephens	65	135,000
45' Chris Craft	73	149,000
44' Gulfstar	79	147,000
44' HiStar	88	215,000
42' Grand Banks Europa	80	189,000
41' Hatteras, nice	65	149,000
38' Fu Hwa	84	125,000
38' Bayliner, nice	90	47,000
35' Cooper Prowler	86	78,000
34' Mainship	81	48,000
34' Sea Ray Sundancer	01	169,000
34' Keylcat	97	175,000
32' Willard	76	29,500
32' Uniflite, t/d	77	37,500
32' Bayliner	78	45,000
32' Silverton FB, 370 hrs	98	59,000
31' Mako	94	35,000
30' Sea Ray 305 DB	88	59,900
30' Wellcraft Scarab w/trlr	87	39,000
29' Regal Commodore	89	87,900
28' Sea Ray	91	37,900
27' Pacemaker	78	15,000
26' Osprey long cabin	03	85,000
26' Osprey	02	98,000
25' Farallones	85	35,000
24' Chaparral, trailer	94	19,000
24' Orca, inboard	99	59,950
24' Bayliner	98	15,900
24' Regal 242 w/trailer	98	37,000
24' Osprey	96	69,500
23' Chaparral, trailer	87	6,000
22' Grady White 222 w/trlr	02	59,000
20' Grady White	97	23,000



TWO J/105s
1999 & 1995. Both clean and lots of gear.
From **\$105,000**



36' SWEDEN, 1984
Swedish-made, performance plus, beautiful teak joinery below. 2 staterooms. **\$75,000**



47' PERRY CUTTER CC, 1980
Anything She Wants. South Beach SF.
New tanks, 6 cyl. Ford Lehman. **\$115,000**



NORSEMAN 447 CENTER COCKPIT, 1984
Newer engine, low hours genset, newer rig and sail.
\$230,000
Also: **NORSEMAN 535, \$549,000**

Hanse Dealer Report

Two 2008 Hanses will be on the Bay later this month!

Larry R. Mayne
Yacht & Ship Broker
Dealer & New Boat Sales Manager

Sales dock slip available, \$300/month



The Friendly ABC Sales Team
Ed, Arnie, Peter, George,
Clay, Teresa, Dana & John



**DRASTIC
REDUCTION**

51' ALEUTIAN, 1978
Center cockpit staysail ketch. In-mast furling, Ford Lehman 120hp. **\$152,900**

NORPAC YACHTS

On
Hwy 101

THERE'S ALWAYS ROOM FOR ANOTHER GOOD BOAT
AT OUR DOCKS - LIST YOUR BOAT NOW!

557 Francisco Blvd., San Rafael, CA 94901

(415) 485-6044 • FAX (415) 485-0335

email: info @ norpacyachts.com

FOR MORE
SEE OUR
norpacyachts.com
WEBSITE

HIGH ENDURANCE CRUISING YACHT



75' NORTH SEA TRLWR YACHT. Awesome Blue Water World Cruiser. Massively built in SCOTLAND to go to sea & stay there. CAPE HORN Vet. Impeccable total refit & yacht conversion. Fully found & loaded incl. strong, economical & long lasting Gardner dsl, main & much more. **Ask \$825,000**



32' FUJI KETCH. Diesel, roller furling, enclosed marine head w/shower, galley w/oven, full cruising keel w/cutaway forefoot. Looks to be in excellent and well-maintained condition. **Asking \$34,500**



130' CAMCRAFT PASSENGER SHIP USCG Inspected & CERTIFIED for 33 overnight guests in 17 stms, SOLAS, low hrs 3508 CATS, 2,000 gph watermaker, MSD & gray water treatment. Inverter banks for silent nvs, 8 days min. endurance w/p reprovisioning. Lying Pac NW. **Ask \$2,000,000.**



50' ADMIRALTY MOTORSAILER KETCH by the famous American Marine Yard. Robust TEAK construction, economical twin Ford-Lehman diesels, radar, GPS, etc. Shower, comfort, seaworthiness, genset, full galley & a lot more. **Asking \$119,900**

ENGLISH ELEGANCE



66' THORNYCROFT CUTTER-RIGGED KETCH Classic 1923 design, well maintained. She's like a beautiful & comfortable private British club down below. Must be seen. Teak decks, diesel, genset, radar and more. Extremely charming and a great performer. **Asking \$199,000**



34' MAINSHIP TRAWLER by Silverton. Flybridge, aux. generator, diesel, dual helms, convertible aft deck enclosure, autopilot, full galley, head & shower. A capable & desirable cruiser & more! **Ask \$49,500**



30' RINKER 300 Fiesta Vee Express, '94 w/near zero hrs on full inside/out remanufacture/refit incl. her twin engines. Aft cabin, quality, comfort, condition & performance. **\$39,500**



30' CATALINA Sloop. One of the all time most popular designs EVER! And this is a nice one! RF, extra nice dodger, galley, fuel, marine head, wheel, Avon inflatable & more! **Asking only \$24,950**

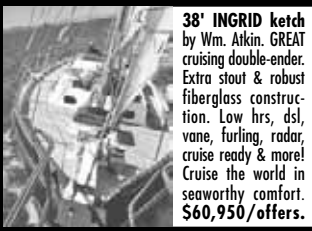

38' INGRID ketch by Wm. Aikin. GREAT cruising double-ender. Extra stout & robust fiberglass construction. Low hrs, dsl, vane, furling, radar, cruise ready & more! Cruise the world in seaworthy comfort. **\$60,950/offers.**



PERFORMANCE CRUISER

37' VILLENAVE Custom Ocean Cruising Cutter designed by JP Villenave & built by Venoco. Super strong cold-molded construction. Dsl (+ spare engine incl), powerful rig, great inventory, inverter, vane, solar, AP, furling, RADAR, dink, WXFax & more! **Ask \$43,950**



30' BRISTOL 29.9. Famous Halsey HERRESCHOFF cruiser/racer. Dsl, extra robust FG construction, roller furling, roomy & comfortable, dodger, pedestal wheel steering & more! This is a great boat. **Ask \$34,950**



42' SPARKMAN & STEPHENS Slp. F/G, dsl engine, spinn., dodger, major refit incl, rig. Beautiful cruiser from world-class architect; she's a very desirable yacht with a great layout, excellent performance & outstanding comfort and cond. Hard to go wrong. **Asking \$52,000**

SAIL

58' ALDEN BOOTHBAY MOTORSAILER Ketch. Dsl, cent. cockpit. Loaded world cruiser 268,950
50' CAULKINS Slp. A project, but all there. Dsl, strip plank, ocean racer... Try 15,000
45' COLUMBIA Center Cockpit, dsl, big comfy live/cruise Ask 44,950
42' SPARKMAN & STEPHENS steel custom cutter by Olin Stephens. Cent. cockpit, aft cabin, dsl & more... Asking 60,950
41' HINCKLEY Ctr. Trad. beauty and a world-class builder..... Ask 69,900
40' BLOCK ISLAND Cutter. Dsl, good wood fixer, 1937 classic..... Asking 9,950
40' NEWPORTER by Ackerman. Dsl, glass, ply, ketch rig. Recent improvements..... REDUCED! Asking 14,950
39' FREYA Double-ender, steel, dsl, dink+o/b, new point, solar, furling, RADAR, AP, cruise equipped + more! ... 62,950
38' KETTENBURG Sloop. Dsl... Ask 43,950
37' GULFSTAR cent. cockpit, aft cabin, dodger, dsl & more..... 43,950
36' ISLANDER Sloop. Major upgrades, dsl, dodger, furling & more.... Ask 44,950
36' STEEL HARTOG ketch, double-ended cruiser, great potential & value. 16,950
36' NIELSEN classic 1918 Danish aux. sloop. Nice condition..... Asking 15,000
35' ERICSON Sloop by ALBERG 16,950
35' SCHOCK Slp. Dsl, spinn., rod rig, teuphol'd. Nice & clean.... Ask 29,500
35' CHEOY LEE by Robb. Dsl, teak... 17,950
34' COLUMBIA Slp. Dsl, furling ++ ... 9,450
33' ISLANDER WAYFARER Slp. Rebit 1/B. Nice!..... Asking 15,450
32' ERICSON Slp. 1/B, heater+... 14,950
32' ALDEN MALABAR Jr., Slp. Lovely Classic w/NEW KEEL BOLTS & much recent upgrading. Bargain! Ask 7,450
30' NEWPORT Slp. 1/B, A/P, F/G... 11,950
29' PEARSON TRITON. New diesel. Total refit nearly done..... Asking 15,950
26' INT'L FOLKBOAT, F/G, O/B... Ask 6,950
25' CHEOY LEE FRISCO FLYER, teak. 8,000
23' HERRESHOFF Classic PRUDENCE Slp w/'03 Honda 7,500

POWER

63' FERRY conversion, 671 diesel, 19.5' beam, excellent condition. Ask 28,000
60' MATTHEWS MY, '65, twin diesels, big, comfortable liveaboard cruiser w/South SF berth..... Asking 215,000
45' STEPHENS 1929 classic.... Try 75,000
43' MATTHEWS, '65, diesel. A gem! Loaded and beautiful Ask 69,450
42' GRAND BANKS Tvl. Aft cabin, FG, Onan, twin dsls, RADAR. Excellent... 121,000
41' HATTERAS twin cabin, twin dsl, glass..... 49,500

41' CHRIS CRAFT CONSTELLATION. Aft cabin. Great liveaboard, full Delta canvas, good condition..... Ask 37,500
40' OWENS, '65 Tahiti. Great for cruise/live, comfort, room & NICE! ... 29,500
39' BOWPICKER, alum, Herring lic. 49,000
38' CHRIS CRAFT, aft cabin, twins, convertible aft enclosure. Very nice! And a BARGAIN! Asking 24,950
36' UNIFLITE, F/B, aft cabin, twins, radar, GPS and more!..... Asking 59,950
36' CHRIS CRAFT CAVALIER. Aft cabin, flybridge, twin V8s, many recent upgrades, very nice. Reduced! 16,450
34' LAKE UNION Dreamboat. Classic 1928. Dsl, shower, beautiful design... 14,950
32' ROBERTS commercial fish w/HERRING PERMIT & more!..... Asking 58,950
32' CARVER. Glass, twins, Sausalito liveaboard berth. Nice! Asking 30,950
31' MONTEREY BAY EXPRESS PH utility, F/G, 1991, twin 130 Yanmars, trailer, USCG-documented, commercial quality gem..... Reduced! Asking 34,950
30' ALUM. CREW/SUPPLY vessel, radar, GPS, scanning sonar, VHF, crane and more. Just refit 35,000

30' WILLARD Trawler, dsl ++ .. Ask 34,950
29' WELLCRAFT 2900 EXPRESS. Twin screw (not redrives). Super clean & nice! Bright red...REDUCED! Asking 19,950
28' RODMAN WA, F/B, 2004. Twin dsls, high quality & loaded. Looks new!..... Asking 189,000
27' FARALLON, '86, twin 5L V8s... 51,950
26' PACEMAKER, cab. cruise w/V8, nice!..... Ask 14,950
26' PENN YAN Express. Twin V8 Tunnel Drives, glass, clean & more - w/trlr... 14,950
25' FARALLON SF w/trailer. New twin 180 hp Volvos, radar, etc.... Asking 22,450
24' SEA RAY V8. Full Delta canvas, tf, o/d, nice!..... Asking 12,000
BOSTON WHALER MONTAUR. Trailer, 88 hp outboard, console, Fishfinder. Fast & NICE!..... Asking 9,500

OTHER

60' STEEL BARGE, 20-ton A frame, spuds, deck house, more..... Offers/55,000
56' LCM-6 with dive support, steel, W/H, twin 671s, full elect..... Try 25,000



57' CHINESE JUNK. Teak const. Huge & very comfortable well lit & well appointed inter. Outstanding liveaboard cruiser w/lug rig & highly desirable Gardner dsl. Charm, character. Gen set, washer/dryer. Great Sausalito slip & more! **Asking \$169,000**



65' CLASSIC, '31 MOTORYACHT BY WHEELER. 16' beam, recent 40k hull refurb. Bottom's good & she's ready for you to finish restoration. Pilothouse, twins, 3 heads, huge salon, crew's quarters & more **Asking \$55,500**



40' CHEOY LEE GULF 40 PILOTHOUSE Sloop. 56hp Yanmar diesel, varnished teak hull, copper rivet fastened. Good sail inventory including 2 spinnakers, AP, radar, chart/GPS, more! Great yacht in great shape. **Asking \$65,000**



32' GRAND BANKS CLASSIC TRAWLER. 1970 Economical diesel, dual helms, flybridge, TEAK decks, full electronics, swim platform, mast and boom. She's a great cruiser and a very well loved design. **Asking \$39,500**

The OLD KERMIT PARKER BROKERAGE
Serving the Boating Community since 1956.

NELSON'S KEEPS

GROWING



Hal Nelson, founder of Nelson's Marine, always looked ahead. When son Carl moved the yard from the Estuary to Alameda Point, Hal thought a garden should be planted to grow along with the yard. Now 10 years and thousands of customers later, the trees, along with the yard, have doubled in size. It's part of a long-term vision for customer and environmental care at Nelson's Marine.



Little Things Make a Big Difference

Travelift operators Curt Schoenfelder and Marty Retta solved a problem for owners and yards with a simple, elegant solution. Sling placement when hauling out a boat is critical, yet no one had provided simple permanent markers for all future haulouts. Nelson's does. We provide discreet, permanent markers for all your future haulouts – simple and safe.



SACRAMENTO AFFILIATE: McClellan Indoor Boat & RV Storage
(916) 640-0141 • www.mcclellanstorage.com



NELSON

Yachts

Brokerage & Hunter Trailers
(510) 337-2870 • see ad p. 33

Sacramento
Yacht Sales
Opening
Soon

Nelson's Marine

1500 FERRY POINT
ALAMEDA, CA 94501
(510) 814-1858 • FAX (510) 769-0815